

AKAI SERVICE MANUAL

(ADDITIONAL)

Use this additional service manual together with the previously published service manual for the AKAI GX-67 and DX-57 models.
For schematic diagrams and PC Boards, please refer to those provided for the GX-67 and DX-57 models.

STEREO CASSETTE DECK

MODEL **GX-69**

MODEL **DX-59**

SPECIFICATIONS

<p>Track System 4 track 2 channel Stereo</p> <p>Heads</p> <p>GX-69 Erase Head x 1 LC-OFC SGX Head for recording x 1 LC-OFC SGX Head for playback x 1</p> <p>DX-59 Erase Head x 1 Hard permalloy Head for recording x 1 Hard permalloy Head for playback x 1</p> <p>Motors Electronic speed controlled DC motor for capstan x 1 DC motor for reel drive x 1 DC motor for tape eject/loading x 1 (GX-69 only)</p> <p>Wow & Flutter 0.045 % (WRMS) 0.08 % (DIN)</p> <p>Tape winding time 80 sec. (C-60)</p> <p>Frequency response</p> <p>GX-69 Normal 15 Hz to 18,000 Hz ±3dB CrO₂ 15 Hz to 18,000 Hz ±3dB Metal 15 Hz to 21,000 Hz ±3dB</p> <p>DX-59 Normal 15 Hz to 17,000 Hz ±3dB CrO₂ 15 Hz to 17,000 Hz ±3dB Metal 15 Hz to 20,000 Hz ±3dB</p> <p>Total harmonic distortion .. 1.0 % (METAL tape)</p> <p>Input sensitivity/Impedance</p> <p>Line 70 mV / 47 k ohms</p>	<p>Output Level/Impedance</p> <p>Line 388 mV / 2 k ohms</p> <p>Headphones 1.3 mW (8 ohms)</p> <p>S/N ratio 57 dB (Measured via Metal tape with peak recording level)</p> <p>Dolby B type</p> <p>NR switch ON Improves up to 5 dB at 1 kHz 10 dB above 5 kHz</p> <p>Dolby C type</p> <p>NR switch ON Improves up to 15 dB at 500 Hz, 20 dB at 1 kHz to 10 kHz</p> <p>Power Requirements AC 220 V- 230 V, 50Hz for Europe except U.K. AC 110 V- 120 V, 220 V-240 V, 50 / 60 Hz Convertible for other countries</p> <p>Power consumption 15 W</p> <p>Dimensions 425 (W) x 135 (H) x 151 (D) mm</p> <p>Weight</p> <p>GX-69 5.4 kg</p> <p>DX-59 5.3 kg</p> <p>Standard accessories</p> <p>Connection cords x 2</p> <p>Remote control unit x 1</p> <p>Dry batteries R6 (AA) size x 2</p> <p>Operator's manual x 1</p>
----------------------------------------------------------------------------------------------------------------------------------------------------------------------------------------------------------------------------------------------------------------------------------------------------------------------------------------------------------------------------------------------------------------------------------------------------------------------------------------------------------------------------------------------------------------------------------------------------------------------------------------------------------------------------------------------------------------------------------------------------------------------------------------------------------------------------------------------------------------------------------------------------------------------------------------------------------------------------------------------------------------------------------	------------------------------------------------------------------------------------------------------------------------------------------------------------------------------------------------------------------------------------------------------------------------------------------------------------------------------------------------------------------------------------------------------------------------------------------------------------------------------------------------------------------------------------------------------------------------------------------------------------------------------------------------------------------------------------------------------------------------------------------------------------------------------------------------------------------------------------------------------------------------------------------------------------------------

0 dBs → 1.775 V

- * For improvement purposes, specifications and design are subject to change without notice.
- * Dolby noise reduction and HX Pro headroom extension manufactured under license from Dolby Laboratories Licensing Corporation. HX Pro originated by Bang & Olufsen.
- * "DOLBY", the double-D symbol and "HX Pro" are trademarks of Dolby Laboratories Licensing Corporation.

I. PARTS LIST

ATTENTION

1. When placing an order for parts, be sure to list the Part No., Model No. and the description of each part. Otherwise, the non-delivery of the part or the delivery of a wrong part may result.
2. Please make sure that Part No. is correct when ordering. If not, a part different from the one you ordered may be delivered.
3. Since the parts shown in Parts List of Preliminary Service Manual may have been the subject of changes, please use this Parts List for all future reference.

HOW TO USE THIS PARTS LIST

1. This Parts List lists those parts which are considered necessary for repairs. Other common parts, such as resistors and capacitors, are listed in the "Common List for Service Parts" from which these parts should be selected and stocked.
2. The Recommended Spare Parts List shows those parts in the Parts List which are considered particularly important for service.
3. Parts not shown in the Parts List and "Common List for Service Parts" will not in principle be supplied.
4. How to read the Parts List.

a) Mechanism Block

2. HEAD BASE BLOCK

Ref. No.	Part No.	Description
1	BH-T2023A320A	HEAD BASE BLOCK
2	HP-H2206A010A	HEAD R/P PR4-8FU C
3	ZS-477876	PAN20*03STL CMT
4	ZS-536488	BID20*08STL CMT
5	ZG-402895	SP CS ANGLE ADJUST

SP (Service Parts) Classification
This number corresponds with the individual parts index number in that figure.

b) PC Board

6. MAIN PC BOARD

Ref. No.	Part No.	Description
IC1	EI-324536	IC HD14049BP
IC2	EI-336801	IC MB8841-564M
C1A	EC-338399	C MMY V 223M 250AC [U,E,B,S]
C1B	EC-350949	C MMY V 223M 250DC [J]
C1C	EC-338397	C MMY V 223M 125AC [C,A]
X1	EI-318384	OSC X'TAL NC-18C

Symbols for primary destination
 [A] : AAL (U.S.A) [S] : SAA (Australia)
 [B] : BEAB (England) [U] : U/T (Universal Area)
 [C] : CSA (Canada)
 [E] : CEE (Europe) [V] : VDE (Germany)
 [J] : JPN (Japan) [Y] : Custom Version

SP (Service Parts) Classification
These reference symbols correspond with component symbols in the Schematic Diagrams.

The available PC Board Blocks are listed separately.

5. When Part No. is known, Parts Index at end of Parts List can be used to locate where that part is shown in Parts List by its Reference No. listed at right of Part No.

WARNING

△ (*) INDICATES SAFETY CRITICAL COMPONENTS. FOR CONTINUED SAFETY, REPLACE SAFETY CRITICAL COMPONENTS ONLY WITH MANUFACTURE'S RECOMMENDED PARTS.

AVERTISSEMENT

△ (*) IL INDIQUE LES COMPOSANTS CRITIQUES DE SÉCURITÉ. POUR MAINTENIR LE DEGRÉ DE SÉCURITÉ DE L'APPAREIL, NE REMPLACER QUE DES PIÈCES RECOMMANDÉES PAR LE FABRICANT.

1. RECOMMENDED SPARE PARTS

We suggest you to stock the following Recommended Spare Part items listed below since they can cover most of the routine service.

Ref. No.	Part No.	Description	Ref. No.	Part No.	Description
1	AX-D4004A010B	REMOCON BLK RC-G57 [DX-59]	52	ES-396610J	SW TACT SOR-122HS T05 [REW]
2	AX-D4004A010A	REMOCON BLK RC-G67 [GX-69]	53	ET-411995J	DETECTOR GP1U581X
3	BB-T2130A050B	MECHA BLK DX-57 [DX-59]	54	ET-396487J	TR DTA124XL T05
4	BB-T2130A050A	MECHA BLK GX-67 [GX-69]	55	ET-371075	TR DTA124XS
5	BM-405969J	MOTOR RF-370 PART [GX-69]	56	ET-373382	TR DTA143ZS
6	*BT-391561J	TRANS POW T2118 U [U]	57	ET-354415	TR DTA144ES
7	*BT-410582J	TRANS POW T2130 E [E]	58	ET-360399	TR DTC114TS
8	ED-307572	D SILICON H 1S5131	59	ET-354365	TR DTC114YS
9	ED-624903	D SILICON H 1S2473 [GX-69]	60	ET-354371	TR DTC124ES
10	*ED-511907	D SILICON 1N4002 100/1.0A	61	ET-354364	TR DTC143TS
11	ED-400221J	D ZENER H HZ11A3LFA F10	62	ET-405594J	TR DTC143ZL T05
12	ED-346574	D ZENER H HZ22-2L	63	ET-373391	TR DTC143ZS
13	ED-346598	D ZENER H HZ4 C2	64	ET-396488J	TR DTC144EL T05
14	*ED-346602	D ZENER H HZ5 B3	65	ET-354414	TR DTC144ES [GX-69]
15	ED-343410	D ZENER H HZ6A1L	66	ET-370310	TR DTC144TS
16	*ED-346525	D ZENER H HZ6A3L	67	ET-347738	TR 2SA1282A E,F F05
17	ED-351419	D ZENER H HZ7B3L	68	ET-364093	TR 2SA1283 E,F
18	ED-346536	D ZENER H HZ7C3L [GX-69]	69	ET-352726	TR 2SA1392 T,U
19	ED-346541	D ZENER H HZ9B2L	70	ET-389803J	TR 2SA933S R,S
20	*EF-358641	FUSE BET T 250V 800MA [E]	71	ET-400218J	TR 2SC1740S R,S
21	*EF-309387	FUSE TSC A 250V 1.00A [U]	72	ET-365394	TR 2SC3242A E,F,G F05
22	EH-370972	FILTER LC LP 370972	73	ET-378524J	TR 2SC3383 S,T,U
23	EI-367572	IC BA15218	74	ET-400741J	TR 2SC3708 T T05
24	EI-373980	IC BA15218N	75	ET-394554J	TR 2SD1379
25	EI-353421	IC BA6229 [GX-69]	76	ET-396072J	TR 2SD2159 V,W
26	EI-384868J	IC BU4030B	77	EV-405297J	VR RK14K12B0 SPL C1253X2 [GX-69]
27	EI-394573J	IC CXA1331S	78	EV-405298J	VR ROTARY RK11K1120 B102
28	EI-394574J	IC LA2000	79	EV-405300J	VR ROTARY RK11K1120 SP W254
29	EI-405496J	IC M50941-6275P 91DECK2 T2130	80	EV-405301J	VR ROTARY RK14K12B0 A503X2
30	EI-360043	IC M5220P	81	EV-405299J	VR ROTARY RK16312A0 A104X2
31	EI-310036	IC TC4066BP			
32	EI-373383	IC UPC1297CA			
33	*EI-377101	IC UPC7805HF			
34	EI-405327J	OSC CE CST6.00MGW 6.000MHZ			
35	EM-405274J1	IND FL CM1068C DOUBLE			
36	EO-361292	COIL FIX 1 RC875 682J [GX-69]			
37	EO-405355J	COIL FIX 3 E1222T472J 472J222J			
38	EO-389245J	COIL OSC 1 T2118 100.0KHZ			
39	EO-400766J	COIL OSC 1 T2128 (HX)-7 200KHZ [GX-69]			
40	EO-405296J	COIL OSC 1 T2130 (HX) 105KHZ [DX-59]			
41	EO-405356J	COIL TUN 1 105Z391S 105KHZ [DX-59]			
42	EO-405304J	COIL TUN 1 210Z181S [GX-69]			
43	*ER-320528	R FUSE H ERD2FC 1/4W 22R0G			
44	*ER-401039J	R FUSE V T05 ERD2FCV 1/4W 4R7J			
45	ES-405288J1	SW LEAF MSW18121MPJO [GX-69]			
46	ES-372912	SW LEAF SPPB21 01-2 [GX-69]			
47	ES-393376J	SW LEAF SPPB22 01-1 [GX-69]			
48	*ES-371104	SW PUSH SDDL1 01-1 [POWER SW]			
49	ES-405302J	SW PUSH SPUY32 3THROW N [DX-59]			
50	ES-405295J	SW PUSH SPUY42 4THROW N [GX-69]			
51	ES-370965	SW SLIDE SSSU02 1-01-03N			

MECHA BLOCK

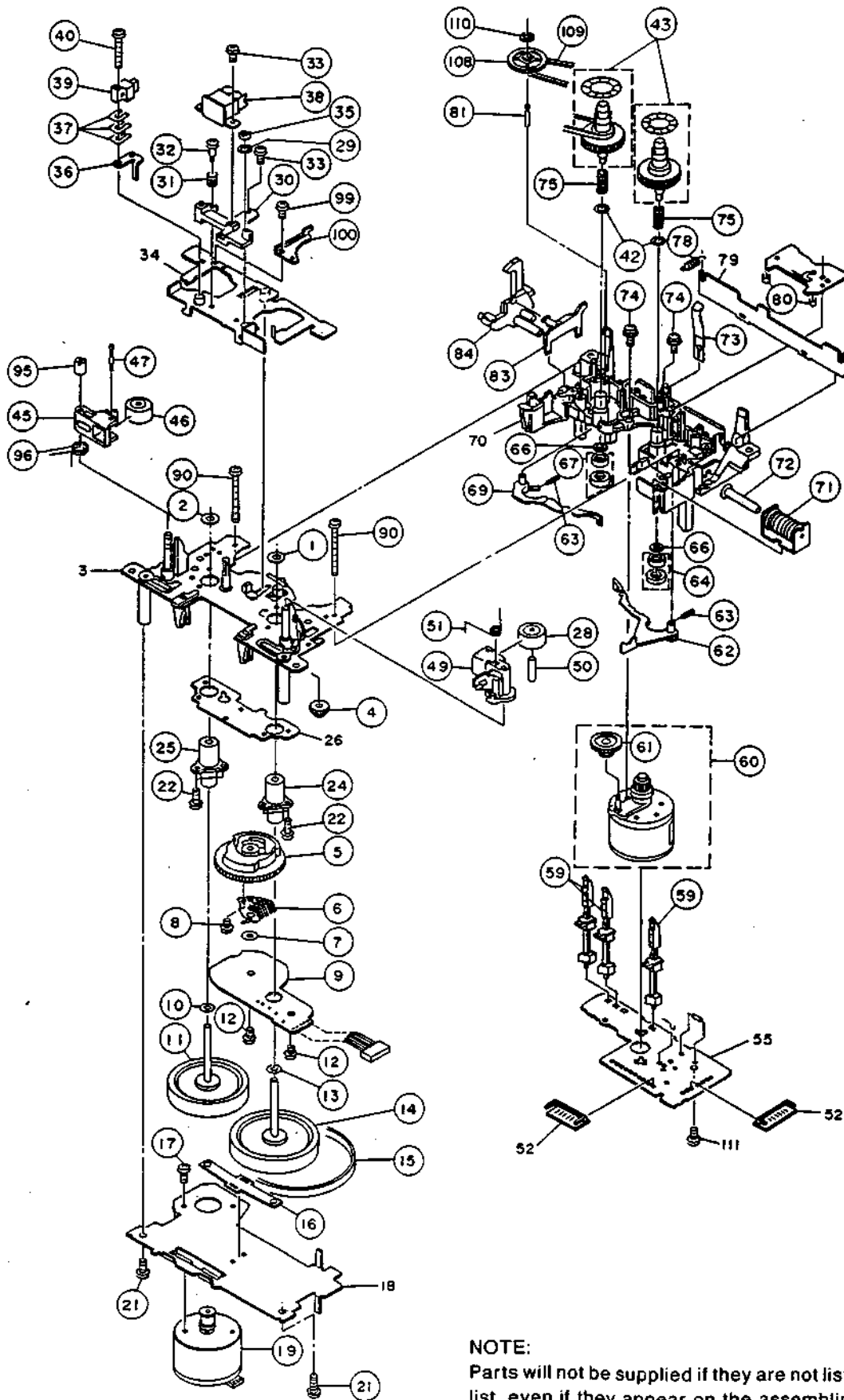

NOTE:
 Parts will not be supplied if they are not listed in the parts list, even if they appear on the assembling illustrations with reference No.

2. MECHA BLOCK

Ref. No.	Part No.	Description
1	ZW-729545J	TW25
2	ZW-729440J	TW22
4	MZ-729441J	GEAR ASSIST
5	MZ-729442J	CAM
6	ES-729443J	SW ROTARY
7	ZW-729444J	WASHER 30X080X050 PSL
8	ZS-729445J	PAN 20X03
9	EA-732798J	PC CONTROL
10	ZW-732799J	WASHER
11	MI-732800J	FLYWHEEL
12	ZS-729449J	PAN 20X30
13	ZW-732801J	WASHER 26X047X050 PSL
14	MI-729453J	FLYWHEEL
15	MB-729451J	BELT CAPSTAN
16	MZ-729452J	HOLDER THRUST
17	ZS-729454J	PAN 26X03
19	BM-732802J	MOTOR CAPSTAN SHE2L55
21	ZS-729456J	SCREW TAPPING 26X08
22	ZS-729457J	ST PAN 20X08
24	MV-729458J	MAIN CASE (R)
25	MV-729459J	MAIN CASE (L)
28	MP-732803J	PINCH ROLLER
29	ZW-732819J	WASHER
30	HZ-732804J	BASE HEAD
31	ZG-729462J	SP AZIMUTH
32	MS-729463J	SHAFT
33	ZS-732805J	ST PAN 20X04
35	ZW-729466J	NUT ADJ
36	HZ-729467J	BASE E HEAD
37A	ZW-729468J	SPACER
37B	ZW-729465J	SPACER
37C	ZW-729546J	SPACER
38A	HR-H2411A010A	HEAD COMB RP4-10TG2 RP4-10TG2 [GX-69]
38B	HR-405284J	HEAD COMBO H2381 [DX-59]
39	HE-729469J	HEAD E 876-30-03
40	ZS-729470J	BID 20X12
42	ZW-732820J	WASHER
43	MT-732806J	REEL TABLE
45	ML-732807J	ARM PINCH ROLLER (S)
46	MP-732808J	PINCH ROLLER
47	MS-732809J	SHAFT PINCH ROLLER
49	ML-732810J	ARM PINCH ROLLER (R)
50	MS-729475J	SHAFT PINCH ROLLER
51	ZG-732811J	SP ARM PINCE ROLLER (R)
59	ES-729477J	LEAF SW
60	BM-732812J	MOTOR REEL PART SGE09014
61	MZ-729479J	GEAR IDLER
62	ML-729480J	LEVER ASSIST (A)
63	ZG-732813J	SP LEVER ASSIST
64	MR-729482J	PULLEY BRAKE (T) PART (WH)
66	ZW-729483J	WASHER 26X055X013 (PSL)
67	MR-729484J	PULLEY BRAKE (S) PART (BK)
69	ML-732814J	LEVER ASSIST (B)
71	EP-729487J	SOLENOID
72	MS-729488J	SHAFT SOLENOID
73	ZG-732815J	SP PLATE CASSETTE HOLDER [DX-59]
74	ZS-729490J	SCREW SPECIAL 26X016
75	ZG-729491J	SP REEL TABLE
78A	ZG-732816J	SP PULL CASSETTE PLATE [GX-69]
78B	ZG-729494J	SP PULL CASSETTE PLATE [DX-59]
80	ET-729496J	TR PHOTO NJL5161KF1 B
81	MS-729497J	SHAFT PULLEY
83	ML-729498J	LEVER
84	ML-729499J	LEVER EJECT
90	ZS-729500J	PAN 26X30
95	ZS-729501J	SCREW ADJ ARM PINCH ROLER
96	ZG-729502J	SP PINCH ROLER (S)
99	ZS-729503J	PAN 20X025
100	MZ-729504J	STOPPER
108	MR-729505J	PULLEY PART
109	MB-732817J	BELT
110	ZW-729507J	WASHER

3. P.C BOARD BLOCK

Ref. No.	Part No.	Description
1A	BA-T2130A020B	PC (#) PREAMP BLK GX-67 (U) [U,E] [GX-69]
1B	BA-T2130A020E	PC (#) PREAMP BLK DX-57 (U) [U,E] [DX-59]
2A	BA-T2130A030A	PC (#) SYSCON BLK GX-67 [GX-69]
2B	BA-T2130A030B	PC (#) SYSCON BLK DX-57 [DX-59]

PC (#) PRE AMP BLK CONSISTS OF FOLLOWING P.C BOARDS.

- PRE AMP P.C BOARD
- HEAD PHONE P.C BOARD
- POWER SW P.C BOARD

PC (#) SYSCON BLK CONSISTS OF FOLLOWING P.C BOARDS.

- SYSCON P.C BOARD
- TIMER SW P.C BOARD
- EJECT SW P.C BOARD (GX-69)

4. PRE AMP P.C BOARD

Ref. No.	Part No.	Description
C801	EC-364978	C EC V CUT SME 102M 16.0DC
C802	EC-364978	C EC V CUT SME 102M 16.0DC
C807A	EC-363490	C EC V CUT SME 222M 16.0DC [GX-69]
C807B	EC-367241	C EC V CUT SME 472M 16.0DC [DX-59]
C811	EC-375358	C EC V CUT SME 103M 16.0DC
C817	EC-364978	C EC V CUT SME 102M 16.0DC
D301	ED-624903	D SILICON H 1S2473 [GX-69]
D302	ED-624903	D SILICON H 1S2473 [GX-69]
D311	ED-624903	D SILICON H 1S2473
D411	ED-624903	D SILICON H 1S2473
D501	ED-624903	D SILICON H 1S2473
D502	ED-624903	D SILICON H 1S2473
D503	ED-346536	D ZENER H HZ7C3L [GX-69]
D504	ED-351419	D ZENER H HZ7B3L
D505	ED-346598	D ZENER H HZ4 C2
D506	ED-624903	D SILICON H 1S2473
D507	ED-624903	D SILICON H 1S2473
D508	ED-624903	D SILICON H 1S2473
D509	ED-624903	D SILICON H 1S2473
D801	*ED-511907	D SILICON 1N4002 100/1.0A
D802	*ED-511907	D SILICON 1N4002 100/1.0A
D803	*ED-511907	D SILICON 1N4002 100/1.0A
D804	*ED-511907	D SILICON 1N4002 100/1.0A
D805	ED-346541	D ZENER H HZ9B2L
D806	ED-346541	D ZENER H HZ9B2L
D807	ED-511907	D SILICON 1N4002 100/1.0A
D808	ED-511907	D SILICON 1N4002 100/1.0A
D809	ED-511907	D SILICON 1N4002 100/1.0A
D810	*ED-346525	D ZENER H HZ6A3L
D811	ED-400221J	D ZENER H HZ11A3LFA F10
D812	ED-511907	D SILICON 1N4002 100/1.0A
D813	ED-511907	D SILICON 1N4002 100/1.0A
D814	*ED-511907	D SILICON 1N4002 100/1.0A
D815	ED-343410	D ZENER H HZ6A1L
D816	ED-511907	D SILICON 1N4002 100/1.0A
D817	ED-511907	D SILICON 1N4002 100/1.0A
D818	ED-346574	D ZENER H HZ22-2L
D819	*ED-346602	D ZENER H HZ5 B3
D820	ED-511907	D SILICON 1N4002 100/1.0A
D821	ED-624903	D SILICON H 1S2473
D822	ED-624903	D SILICON H 1S2473
D823	ED-624903	D SILICON H 1S2473
D824	ED-511907	D SILICON 1N4002 100/1.0A
FL101	EO-405304J	COIL TUN 1 210Z181S [GX-69]
FL141A	EO-405304J	COIL TUN 1 210Z181S [GX-69]
FL141B	EO-405356J	COIL TUN 1 105Z391S 105KHZ [DX-59]
FL171	EH-370972	FILTER LC LP 370972
FL201	EO-405304J	COIL TUN 1 210Z181S [GX-69]
FL241A	EO-405304J	COIL TUN 1 210Z181S [GX-69]
FL241B	EO-405356J	COIL TUN 1 105Z391S 105KHZ [DX-59]
FL271	EH-370972	FILTER LC LP 370972
FR800	*ER-401039J	R FUSE V T05 ERD2FCV 1/4W 4R7J
FR801	*ER-401039J	R FUSE V T05 ERD2FCV 1/4W 4R7J
FR802	*ER-320528	R FUSE H ERD2FC 1/4W 22R0G
IC101	EI-360043	IC M5220P
IC121	EI-394573J	IC CXA1331S
IC141	EI-367572	IC BA15218
IC171	EI-394573J	IC CXA1331S
IC301	EI-373980	IC BA15218N
IC311	EI-373980	IC BA15218N
IC401	EI-373383	IC UPC1297CA
IC501	EI-394574J	IC LA2000
IC502	EI-384868J	IC BU4030B
IC503	EI-310036	IC TC4066BP
IC504	EI-353421	IC BA6229 [GX-69]
IC505	EI-353421	IC BA6229
IC801	*EI-377101	IC UPC7805HF
J302	EJ-336905	PIN J AJC-035-ACB P 4P

Ref. No.	Part No.	Description
L141	EO-405355J	COIL FIX 3 E1222T472J 472J222J
L241	EO-405355J	COIL FIX 3 E1222T472J 472J222J
L301	EO-361292	COIL FIX 1 RC875 682J [GX-69]
R306	ER-378672J	R OMF H S10 FS 1/2W 181J
R307	ER-378672J	R OMF H S10 FS 1/2W 181J
SW101A	ES-405295J	SW PUSH SPUY42 4THROW N [GX-69]
SW101B	ES-405302J	SW PUSH SPUY32 3THROW N [DX-59]
T321A	EO-400766J	COIL OSC 1 T2128 (HX)-7 200KHZ [GX-69]
T321B	EO-405296J	COIL OSC 1 T2130 (HX) 105KHZ [DX-59]
T322	EO-389245J	COIL OSC 1 T2118 100.0KHZ
T421A	EO-400766J	COIL OSC 1 T2128 (HX)-7 200KHZ [GX-69]
T421B	EO-405296J	COIL OSC 1 T2130 (HX) 105KHZ [DX-59]
TR101	ET-400218J	TR 25C1740S R,S
TR102	ET-378524J	TR 25C3383 S,T,U
TR103	ET-352726	TR 25A1392 T,U
TR140	ET-400218J	TR 25C1740S R,S
TR141	ET-400218J	TR 25C1740S R,S [GX-69]
TR142	ET-400218J	TR 25C1740S R,S
TR143	ET-400218J	TR 25C1740S R,S
TR144	ET-400218J	TR 25C1740S R,S
TR145	ET-400218J	TR 25C1740S R,S
TR146	ET-389803J	TR 25A933S R,S
TR201	ET-400218J	TR 25C1740S R,S
TR240	ET-400218J	TR 25C1740S R,S
TR241	ET-400218J	TR 25C1740S R,S [GX-69]
TR242	ET-400218J	TR 25C1740S R,S
TR243	ET-400218J	TR 25C1740S R,S
TR244	ET-400218J	TR 25C1740S R,S
TR245	ET-400218J	TR 25C1740S R,S
TR301	ET-378524J	TR 25C3383 S,T,U
TR311	ET-354414	TR DTC144ES [GX-69]
TR321	ET-400218J	TR 25C1740S R,S
TR322	ET-400218J	TR 25C1740S R,S
TR323	ET-373391	TR DTC143ZS
TR324	ET-370310	TR DTC144TS
TR325	ET-370310	TR DTC144TS
TR326	ET-354371	TR DTC124ES
TR327	ET-396072J	TR 25D2159 V,W
TR328	ET-400741J	TR 25C3708 T T05
TR329	ET-400741J	TR 25C3708 T T05
TR330	ET-354364	TR DTC143TS
TR401	ET-378524J	TR 25C3383 S,T,U
TR411	ET-354414	TR DTC144ES [GX-69]
TR501	ET-360399	TR DTC114TS
TR502	ET-373382	TR DTA143ZS
TR503	ET-373382	TR DTA143ZS
TR504	ET-354365	TR DTC114YS
TR505	ET-396072J	TR 25D2159 V,W
TR506	ET-396072J	TR 25D2159 V,W
TR507	ET-354365	TR DTC114YS
TR508	ET-354365	TR DTC114YS
TR509	ET-394554J	TR 25D1379
TR510	ET-354365	TR DTC114YS
TR801	ET-365394	TR 25C3242A E,F,G F05
TR802	ET-347738	TR 25A1282A E,F F05
TR804	*ET-378524J	TR 25C3383 S,T,U
TR805	ET-400218J	TR 25C1740S R,S
TR806	ET-364093	TR 25A1283 E,F
VR101	EV-394962J	R S-FIX H T05EVNDXAA03 0.1W10
VR102	EV-389478J	R S-FIX H T05EVNDXAA03 0.1W10
VR171	EV-397174J	R S-FIX H T05EVNDXAA03 0.1W60
VR181	EV-389482J	R S-FIX H T05EVNDXAA03 0.1W60 [GX-69]
VR201	EV-394962J	R S-FIX H T05EVNDXAA03 0.1W10
VR202	EV-389478J	R S-FIX H T05EVNDXAA03 0.1W10
VR271	EV-397174J	R S-FIX H T05EVNDXAA03 0.1W60
VR281	EV-389482J	R S-FIX H T05EVNDXAA03 0.1W60 [GX-69]
VR311	EV-389479J	R S-FIX H T05EVNDXAA03 0.1W20
VR321	EV-389482J	R S-FIX H T05EVNDXAA03 0.1W60

Ref. No.	Part No.	Description
VR322A	EV-389481J	R S-FIX H T05EVNDXAA03 0.1W473 [GX-69]
VR322B	EV-397174J	R S-FIX H T05EVNDXAA03 0.1W683 [DX-59]
VR323	EV-389476J	R S-FIX H T05EVNDXAA03 0.1W103
VR423	EV-389476J	R S-FIX H T05EVNDXAA03 0.1W103
VR901	EV-405297J	VR RK14K12B0 SPL C1253X2 [GX-69]
VR902	EV-405298J	VR ROTARY RK11K1120 B102
VR903	EV-405299J	VR ROTARY RK16312A0 A104X2
VR904	EV-405300J	VR ROTARY RK11K1120 SP W254
VR905	EV-405301J	VR ROTARY RK14K12B0 A503X2
F1A	*EF-309387	FUSE TSC A 250V 1.00A [U]
F1B	*EF-358641	FUSE BET T 250V 800MA [E]
F2A	*EF-309387	FUSE TSC A 250V 1.00A [U]
F2B	*EF-358641	FUSE BET T 250V 800MA [E]

5. HEAD PHONE P.C BOARD

Ref. No.	Part No.	Description
J301	EJ-369995	PHONE J 3P HLJ0540-410 GP 6.3

6. POWER SW P.C BOARD

Ref. No.	Part No.	Description
C815	*EC-338411	C CE V DE7150 FZ 103P 400AC
SW801	*ES-371104	SW PUSH SDDL1 01-1 [POWER SW]

7. SYSCON P.C BOARD

Ref. No.	Part No.	Description
D701	ED-307572	D SILICON H 1SS131
D702	ED-307572	D SILICON H 1SS131
D703	ED-307572	D SILICON H 1SS131
D704	ED-307572	D SILICON H 1SS131
D705	ED-307572	D SILICON H 1SS131
D706	ED-307572	D SILICON H 1SS131
D707	ED-307572	D SILICON H 1SS131
D708	ED-307572	D SILICON H 1SS131
D709	ED-307572	D SILICON H 1SS131
D710	ED-307572	D SILICON H 1SS131
D711	ED-307572	D SILICON H 1SS131 [GX-69]
D712	ED-307572	D SILICON H 1SS131
D713	ED-307572	D SILICON H 1SS131
D714	ED-307572	D SILICON H 1SS131 [GX-69]
D715	ED-307572	D SILICON H 1SS131
D716	ED-307572	D SILICON H 1SS131
D717	ED-307572	D SILICON H 1SS131
D718	ED-307572	D SILICON H 1SS131 [GX-69]
D719	ED-307572	D SILICON H 1SS131
D720	ED-307572	D SILICON H 1SS131
D721	ED-307572	D SILICON H 1SS131
D722	ED-307572	D SILICON H 1SS131
D723	ED-307572	D SILICON H 1SS131 [GX-69]
D724	ED-307572	D SILICON H 1SS131 [GX-69]
D725	ED-307572	D SILICON H 1SS131
D726	ED-307572	D SILICON H 1SS131
D727	ED-307572	D SILICON H 1SS131 [GX-69]
D728	ED-307572	D SILICON H 1SS131
D729	ED-307572	D SILICON H 1SS131
D730	ED-307572	D SILICON H 1SS131
IC701	EI-405498J	IC M50941-627SP 91DECK2 T2130

Ref. No.	Part No.	Description
IN701	EM-405274J1	IND FL CM1068C DOUBLE
RM701	ET-411995J	DETECTOR GP1U581X
TR701	ET-400218J	TR 2SC1740S R,S
TR702	ET-400218J	TR 2SC1740S R,S
TR703	ET-405594J	TR DTC143ZL T05
TR704	ET-396487J	TR DTA124XL T05
TR705	ET-396488J	TR DTC144EL T05
TR706	ET-396487J	TR DTA124XL T05
TR707	ET-396488J	TR DTC144EL T05
TR708	ET-396487J	TR DTA124XL T05
TR709	ET-396488J	TR DTC144EL T05
TR710	ET-396487J	TR DTA124XL T05
TR711	ET-371075	TR DTA124XS
TR712	ET-354414	TR DTC144ES
TR713	ET-371075	TR DTA124XS
TR714	ET-354414	TR DTC144ES
TR715	ET-371075	TR DTA124XS
TR716	ET-354414	TR DTC144ES
TR717	ET-354414	TR DTC144ES [GX-69]
TR718	ET-354415	TR DTA144ES
TR719	ET-354415	TR DTA144ES [GX-69]
TR720	ET-354415	TR DTA144ES
TR721	ET-354415	TR DTA144ES [GX-69]
TR722	ET-354415	TR DTA144ES
TR723	ET-354415	TR DTA144ES
TR724	ET-354415	TR DTA144ES [GX-69]
TR725	ET-354415	TR DTA144ES
TS701	ES-396610J	SW TACT SOR-122HS T05 [REW]
TS702	ES-396610J	SW TACT SOR-122HS T05 [PLAY]
TS703	ES-396610J	SW TACT SOR-122HS T05 [FF]
TS704	ES-396610J	SW TACT SOR-122HS T05 [REC]
TS705	ES-396610J	SW TACT SOR-122HS T05 [STOP]
TS706	ES-396610J	SW TACT SOR-122HS T05 [AUTO MUTE]
TS707	ES-396610J	SW TACT SOR-122HS T05 [COUNTER RESET]
TS708	ES-396610J	SW TACT SOR-122HS T05 [COUNTER MEMORY]
TS709	ES-396610J	SW TACT SOR-122HS T05 [COUNTER MODE][GX-69]
TS710	ES-396610J	SW TACT SOR-122HS T05 [TAPE LENGTH][GX-69]
TS711	ES-396610J	SW TACT SOR-122HS T05 [TAPE MONITOR]
X701	EI-405327J	OSC CE CST6.00MGW 6.000MHZ

8. TIMER SW P.C BOARD

Ref. No.	Part No.	Description
SW701	ES-370965	SW SLIDE SSSU02 1-01-03N

9. EJECT SW P.C BOARD (GX-67)

Ref. No.	Part No.	Description
TS712	ES-396610J	SW TACT SOR-122HS T05

FINAL ASSEMBLY BLOCK

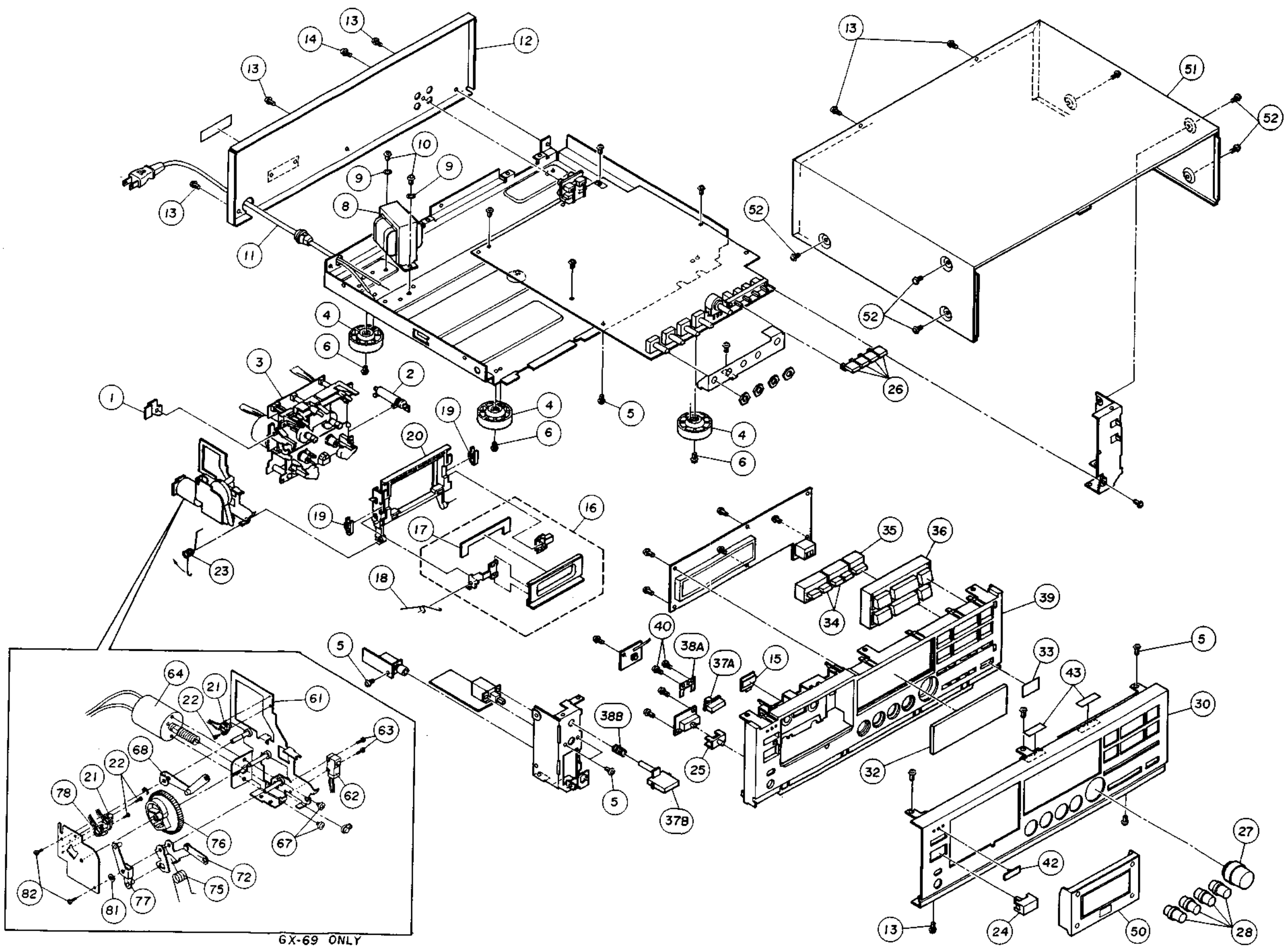

GX-69 ONLY

PARTS LIST

10. FINAL ASSEMBLY BLOCK

Ref. No.	Part No.	Description
1	MZ-391475J	PLATE EJECT [DX-59]
2	MZ-391606J	DAMPER K-106
3A	BB-T2130A050A	MECHA BLK GX-67 [GX-69]
3B	BB-T2130A050B	MECHA BLK DX-57 [DX-59]
4	SA-379375	FOOT (N)
5	ZS-305827	ST BID30X06STL BNI
6	ZS-336714	ST BID30X12STL CMT
8A	*BT-391561J	TRANS POW T2118 U [U]
8B	*BT-410582J	TRANS POW T2130 E [E]
9	ZW-273914	SW40
10	ZS-322580	ST BID40X08STL BNI
11A	*EW-363656	AC CORD200 0129AVFF B200 A U/T [U]
11B	*EW-363669J1	AC CORD200 0364 LCFL B200 A EV [E]
12A	SP-411822J	PANEL REAR GX-69 (U)
12B	SP-411824J	PANEL REAR GX-69 (E)
12C	SP-411823J	PANEL REAR DX-59 (U)
12D	SP-411825J	PANEL REAR DX-59 (E)
13	ZS-358953	ST BID30X08STL BNI
14	ZS-331532	PT BID30X08STL BNI
15	ED-344244	D LED SLF-601C AMBER
16	BZ-391578J	LID STABILIZER PART [GX-69]
17	SZ-391531J	SHEET DAMP [GX-69]
18	ZG-391481J	SP TORSION STABILIZER (L) [GX-69]
19	ZG-336615	SP PLATE CASSETTE HOLDER (B)
20	TC-405054J3	CASSETTE CASE
21	ES-393376J	SW LEAF SPPB22 01-1 [GX-69]
22	ZS-608106	PAN20X06STL CMT [GX-69]
23	ZG-405059J	SP TORSION (EJECT)
24	SK-404769J	BUTTON POWER-B
25	SK-405070J	KNOB TIMER-B
26	SK-405072J	BUTTON PUSH (1)
27	SK-405067J	KNOB VR (1)
28	SK-405068J	KNOB VR (2)
30A	SP-416095J	PANEL FRONT GX-69
30B	SP-416096J	PANEL FRONT DX-59
32	SE-405062J	WINDOW FLD
33	SZ-361424	PLATE REMOCON
34	SK-405064J1	BUTTON COUNTER (1)
35	SK-405065J1	BUTTON MONITOR (1)
36	SK-405063J1	BUTTON OP GX-Z6300
37A	SK-405069J	BUTTON EJECT (1) [GX-69]
37B	SK-416094J	BUTTON EJECT [DX-59]
38A	ZG-405048J	SP PLATE EJECT [GX-69]
38B	ZG-405061J	SP PUSH (EJECT) [DX-59]
39	SP-405097J1	PANEL ESCUTCHEON GX-Z6300
40	ZS-390457J	BT PAN20X04STL BZN
42	SM-365756C	NAME PLATE AKAI (2)
43	SZ-378311-A	CUSHION
50A	BD-T2130A090A	LID PANEL BLK GX-Z6300EV-B [GX-69]
50B	BD-T2130A090B	LID PANEL BLK GX-Z5300-B [DX-59]
51	SP-391493J	COVER UPPER B
52	ZS-322580	ST BID40X08STL BNI
61	MZ-405106J	HOLDER (L) PART [GX-69]
62	ES-405288J1	SW LEAF MSW18121MPJO [GX-69]
63	ZS-487091	PAN23X08STL CMT [GX-69]
64	BM-405969J	MOTOR RF-370 PART [GX-69]

Ref. No.	Part No.	Description
67	ZS-432674	PAN30X03STL CMT [GX-69]
68	ML-405041J	ARM LOCK (1) PART [GX-69]
71	ZW-410051	RETAINING RING E250SUP CMT [GX-69]
72	ML-405038J	ARM EJECT (2) PART [GX-69]
75	ZG-405058J	SP TORSION (EJ) ARM [GX-69]
76	MZ-405056J	GEAR CAM EJECT [GX-69]
77	ML-405036J	ARM EJECT (1) PART [GX-69]
78	ES-372912	SW LEAF SPPB21 01-2 [GX-69]
81	ZW-439018	PW30X060X030STL NI3 [GX-69]
82	ZS-460440	PAN20X04STL CMT [GX-69]
83X	*ES-359606	SW SELECTOR JUH1420-0201 01-4 [U]

NOTE:

Parts will not be supplied if they are not listed in the parts list, even if they appear on the assembling illustrations with reference No.

11. ACCESSORY

Ref. No.	Part No.	Description
1	EW-383168J1	CORD TC-C-05S P-P 2P 2PCS
2A	AX-D4004A010A	REMOCON BLK RC-G67 [GX-69]
2B	AX-D4004A010B	REMOCON BLK RC-G57 [DX-59]

INDEX

Part No.	Ref. No.	Part No.	Ref. No.	Part No.	Ref. No.	Part No.	Ref. No.
AXD4004A010A	11-2A	ED511907	4-D808	ES393376J	10-21	ET400218J	4-TR142
AXD4004A010B	11-2B	ED511907	4-D809	ES396610J	7-TS701	ET400218J	4-TR143
BAT2130A020B	3-1A	ED511907	4-D812	ES396610J	7-TS702	ET400218J	4-TR144
BAT2130A020E	3-1B	ED511907	4-D813	ES396610J	7-TS703	ET400218J	4-TR145
BAT2130A030A	3-2A	ED511907	4-D814	ES396610J	7-TS704	ET400218J	4-TR201
BAT2130A030B	3-2B	ED511907	4-D816	ES396610J	7-TS705	ET400218J	4-TR240
BBT2130A050A	10-3A	ED511907	4-D817	ES396610J	7-TS706	ET400218J	4-TR241
BBT2130A050B	10-3B	ED511907	4-D820	ES396610J	7-TS707	ET400218J	4-TR242
BDT2130A090A	10-50A	ED511907	4-D824	ES396610J	7-TS708	ET400218J	4-TR243
BDT2130A090B	10-50B	ED624903	4-D301	ES396610J	7-TS709	ET400218J	4-TR244
BM405969J	10-64	ED624903	4-D302	ES396610J	7-TS710	ET400218J	4-TR245
BM732802J	2-19	ED624903	4-D311	ES396610J	7-TS711	ET400218J	4-TR321
BM732812J	2-60	ED624903	4-D411	ES396610J	9-TS712	ET400218J	4-TR322
BT391561J	10-8A	ED624903	4-D501	ES405288J1	10-62	ET400218J	4-TR805
BT410582J	10-8B	ED624903	4-D502	ES405295J	4-SW101A	ET400218J	7-TR701
BZ391578J	10-16	ED624903	4-D506	ES405302J	4-SW101B	ET400218J	7-TR702
EA732798J	2-9	ED624903	4-D507	ES729443J	2-6	ET400741J	4-TR328
EC338411	6-C815	ED624903	4-D508	ES729477J	2-59	ET400741J	4-TR329
EC363490	4-C807A	ED624903	4-D509	ET347738	4-TR802	ET405594J	7-TR703
EC364978	4-C801	ED624903	4-D821	ET352726	4-TR103	ET411995J	7-RM701
EC364978	4-C802	ED624903	4-D822	ET354364	4-TR330	ET729496J	2-60
EC364978	4-C817	ED624903	4-D823	ET354365	4-TR504	EV389476J	4-VR323
EC367241	4-C807B	EF309387	4-F1A	ET354365	4-TR507	EV389476J	4-VR423
EC375358	4-C811	EF309387	4-F2A	ET354365	4-TR508	EV389478J	4-VR102
ED307572	7-D701	EF358641	4-F1B	ET354365	4-TR510	EV389478J	4-VR202
ED307572	7-D702	EF358641	4-F2B	ET354371	4-TR326	EV389479J	4-VR311
ED307572	7-D703	EH370972	4-FL171	ET354414	4-TR311	EV389481J	4-VR322A
ED307572	7-D704	EH370972	4-FL271	ET354414	4-TR411	EV389482J	4-VR181
ED307572	7-D705	EI310036	4-IC503	ET354414	7-TR712	EV389482J	4-VR281
ED307572	7-D706	EI353421	4-IC504	ET354414	7-TR714	EV389482J	4-VR321
ED307572	7-D707	EI353421	4-IC505	ET354414	7-TR716	EV394962J	4-VR101
ED307572	7-D708	EI360043	4-IC101	ET354414	7-TR717	EV394962J	4-VR201
ED307572	7-D709	EI367572	4-IC141	ET354415	7-TR718	EV397174J	4-VR171
ED307572	7-D710	EI373383	4-IC401	ET354415	7-TR719	EV397174J	4-VR271
ED307572	7-D711	EI373980	4-IC301	ET354415	7-TR720	EV397174J	4-VR322B
ED307572	7-D712	EI373980	4-IC311	ET354415	7-TR721	EV405297J	4-VR901
ED307572	7-D713	EI377101	4-IC801	ET354415	7-TR722	EV405298J	4-VR902
ED307572	7-D714	EI384868J	4-IC502	ET354415	7-TR723	EV405299J	4-VR903
ED307572	7-D715	EI394573J	4-IC121	ET354415	7-TR724	EV405300J	4-VR904
ED307572	7-D716	EI394573J	4-IC171	ET354415	7-TR725	EV405301J	4-VR905
ED307572	7-D717	EI394574J	4-IC501	ET360399	4-TR501	EW363656	10-11A
ED307572	7-D718	EI405327J	7-X701	ET364093	4-TR806	EW363669J1	10-11B
ED307572	7-D719	EI405498J	7-IC701	ET365394	4-TR801	EW363168J1	11-1
ED307572	7-D720	EJ336905	4-J302	ET370310	4-TR324	HE729489J	2-39
ED307572	7-D721	EJ369995	5-J301	ET370310	4-TR325	HRH2411A010A	2-38A
ED307572	7-D722	EM405274J1	7-IN701	ET371075	7-TR711	HR405284J	2-38B
ED307572	7-D723	EO361292	4-L331	ET371075	7-TR713	HZ729467J	2-36
ED307572	7-D724	EO389245J	4-T322	ET371075	7-TR715	HZ732804J	2-30
ED307572	7-D725	EO400766J	4-T321A	ET373382	4-TR502	MB729451J	2-15
ED307572	7-D726	EO400766J	4-T421A	ET373382	4-TR503	MB732817J	2-109
ED307572	7-D727	EO405296J	4-T321B	ET373391	4-TR323	MI729453J	2-14
ED307572	7-D728	EO405296J	4-T421B	ET378524J	4-TR102	MI732800J	2-11
ED307572	7-D729	EO405304J	4-FL101	ET378524J	4-TR301	ML405036J	10-77
ED307572	7-D730	EO405304J	4-FL141A	ET378524J	4-TR401	ML405038J	10-72
ED343410	4-D815	EO405304J	4-FL201	ET378524J	4-TR804	ML405041J	10-68
ED344244	10-15	EO405304J	4-FL241A	ET389803J	4-TR146	ML729480J	2-62
ED346525	4-D810	EO405355J	4-L141	ET394554J	4-TR509	ML729498J	2-83
ED346536	4-D503	EO405355J	4-L241	ET396072J	4-TR327	ML729499J	2-84
ED346541	4-D805	EO405356J	4-FL141B	ET396072J	4-TR505	ML732807J	2-45
ED346541	4-D806	EO405356J	4-FL241B	ET396072J	4-TR506	ML732810J	2-49
ED346574	4-D818	EP729487J	2-71	ET396487J	7-TR704	ML732814J	2-69
ED346598	4-D505	ER320528	4-FR802	ET396487J	7-TR706	MP732803J	2-28
ED346602	4-D819	ER378672J	4-R306	ET396487J	7-TR708	MP732808J	2-46
ED351419	4-D504	ER378672J	4-R307	ET396487J	7-TR710	MR729482J	2-64
ED400221J	4-D811	ER401039J	4-FR800	ET396488J	7-TR705	MR729484J	2-67
ED511907	4-D801	ER401039J	4-FR801	ET396488J	7-TR707	MR729505J	2-108
ED511907	4-D802	ES359606	10-83X	ET396488J	7-TR709	MS729463J	2-32
ED511907	4-D803	ES370965	8-SW701	ET400218J	4-TR101	MS729475J	2-50
ED511907	4-D804	ES371104	6-SW801	ET400218J	4-TR140	MS729488J	2-72
ED511907	4-D807	ES372912	10-78	ET400218J	4-TR141	MS729497J	2-81

Part No.	Ref. No.	Part No.	Ref. No.	Part No.	Ref. No.	Part No.	Ref. No.
MS732809J	2-47	ZS729500J	2-90				
MT732806J	2-43	ZS729501J	2-96				
MV729458J	2-24	ZS729503J	2-99				
MV729459J	2-25	ZS732805J	2-33				
MZ391475J	10-1	ZW273914	10-9				
MZ391606J	10-2	ZW410051	10-71				
MZ405056J	10-76	ZW439018	10-81				
MZ405106J	10-61	ZW729440J	2-2				
MZ729441J	2-4	ZW729444J	2-7				
MZ729442J	2-5	ZW729465J	2-37B				
MZ729452J	2-16	ZW729466J	2-35				
MZ729479J	2-61	ZW729468J	2-37A				
MZ729504J	2-100	ZW729483J	2-66				
SA379375	10-4	ZW729507J	2-110				
SE405062J	10-32	ZW729545J	2-1				
SK404769J	10-24	ZW729546J	2-37C				
SK405063J1	10-36	ZW732799J	2-10				
SK405064J1	10-34	ZW732801J	2-13				
SK405065J1	10-35	ZW732819J	2-29				
SK405067J	10-27	ZW732820J	2-42				
SK405068J	10-28						
SK405069J	10-37A						
SK405070J	10-25						
SK405072J	10-26						
SK416094J	10-37B						
SM365756C	10-42						
SP391493J	10-51						
SP405097J1	10-39						
SP411822J	10-12A						
SP411823J	10-12C						
SP411824J	10-12B						
SP411825J	10-12D						
SP416095J	10-30A						
SP416096J	10-30B						
SZ361424	10-33						
SZ378311-A	10-43						
SZ381531J	10-17						
TC405054J3	10-20						
ZG336615	10-19						
ZG391481J	10-18						
ZG405048J	10-38A						
ZG405058J	10-75						
ZG405059J	10-23						
ZG405061J	10-38B						
ZG729462J	2-31						
ZG729491J	2-75						
ZG729494J	2-78B						
ZG729502J	2-96						
ZG732811J	2-51						
ZG732813J	2-63						
ZG732815J	2-73						
ZG732816J	2-78A						
ZS305827	10-5						
ZS322580	10-10						
ZS322580	10-52						
ZS331532	10-14						
ZS336714	10-6						
ZS338953	10-13						
ZS390457J	10-40						
ZS432674	10-67						
ZS460440	10-82						
ZS487091	10-63						
ZS608106	10-22						
ZS729445J	2-8						
ZS729449J	2-12						
ZS729454J	2-17						
ZS729456J	2-21						
ZS729457J	2-22						
ZS729470J	2-40						
ZS729490J	2-74						

AKAI SERVICE MANUAL

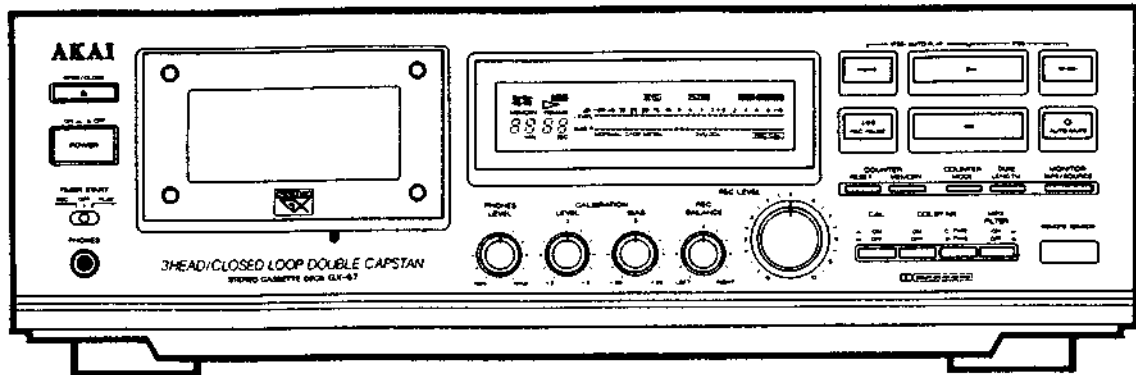

MODEL GX-67

STEREO CASSETTE DECK

MODEL **GX-67**
MODEL **DX-57**

SPECIFICATIONS

Track System	4 track 2 channel Stereo	S/N ratio	57 dB (Measured via Metal tape with peak recording level)
Heads		Dolby B type NR	Improves up to 5 dB at switch ON : 1 kHz, 10 dB above 5 kHz
GX-67	Erase Head x 1 LC-OFC SGX Head for recording x 1 LC-OFC SGX Head for playback x 1	Dolby C type NR	Improves up to 15 dB at switch ON : 500 Hz, 20 dB at 1 kHz to 10 kHz
DX-57	Erase Head x 1 Hard permalloy Head for recording x 1 Hard permalloy Head for playback x 1	Total Harmonic Distortion	1.0 %
Motors	Electronic speed controlled DC motor for capstan x 1 DC motor for reel drive x 1 DC motor for tape eject/loading x 1 (GX-67 only)	Input Level/Impedance	
Wow & Flutter	0.045 % (WRMS) 0.08 % (DIN)	Line	70 mV / 47 kohms
Tape winding time	80 sec. (C-60)	Output Level/Impedance	
Frequency Response		Line	388 mV / 2 kohms
GX-67 Normal	15 Hz to 18,000 Hz ± 3 dB	Headphones	1.3 mW / (8 ohms)
CrO ₂	15 Hz to 18,000 Hz ± 3 dB	Power Requirements	AC 220 V- 230 V, 50 Hz for Europe except UK AC 240 V, 50 Hz for UK AC 110 V- 120 V, 220 V-240 V, 50 / 60 Hz Convertible for other countries
Metal	15 Hz to 21,000 Hz ± 3 dB	Dimensions	425 (W) x 135 (H) x 351 (D) mm
DX-57 Normal	15 Hz to 17,000 Hz ± 3 dB	Weight	
CrO ₂	15 Hz to 17,000 Hz ± 3 dB	GX-67	5.4 kg
Metal	15 Hz to 20,000 Hz ± 3 dB	DX-57	5.3 kg
		Standard accessories	
		Connection cords	x 2
		Remote control unit	x 1
		Dry batteries R6 (AA) size	x 2
		Operator's manual	x 1

0 dBs = 0.775 V

- * For improvement purposes, specifications and design are subject to change without notice.
- * Dolby noise reduction and HX Pro headroom extension manufactured under license from Dolby Laboratories Licensing Corporation. HX Pro originated by Bang & Olufsen.
- * "DOLBY", the double-D symbol  and "HX Pro" are trademarks of Dolby Laboratories Licensing Corporation.

★ SAFETY INSTRUCTIONS

PRECAUTIONS DURING SERVICING

- Parts identified by the Δ (*) symbol are critical for safety. Replace only with parts number specified.
- In addition to safety, other parts and assemblies are specified for conformance with such regulations as those applying to spurious radiation.
These must also be replaced only with specified replacements.
Examples: RF converters, tuner units, antenna selector switches, RF cables, noise blocking capacitors, noise blocking filters, etc.
- Use specified internal wiring. Note especially:
 - Wires covered with PVC tubing
 - Double insulated wires
 - High voltage leads
- Use specified insulating materials for hazardous live parts. Note especially:
 - Insulation Tape
 - PVC tubing
 - Spacers (Insulating barriers)
 - Insulation sheets for transistors
 - Plastic screws for fixing microswitch (especially in turntable)
- When replacing AC primary side components (transformers, power cords, noise blocking capacitors, etc.), wrap ends of wires securely about the terminals before soldering.

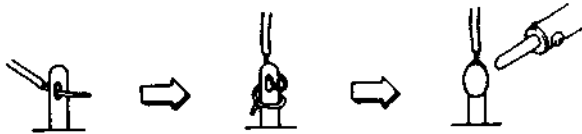

- Observe that wires do not contact heat producing parts (heatsinks, oxide metal film resistors, fusible resistors, etc.).

- Check that replaced wires do not contact sharp edged or pointed parts.
- Also check areas surrounding repaired locations.
- Use care that foreign objects (screws, solder droplets, etc.) do not remain inside the set.

SAFETY CHECK AFTER SERVICING

After servicing, make measurements of leakage-current or resistance in order to determine that exposed parts are acceptably insulated from the supply circuit. The leakage-current measurement should be done between accessible metal parts (such as chassis, ground terminal, microphone jacks, signal input/output connectors, etc.) and the earth ground through a resistor of 1500 ohms paralleled with a 0.15 μ F capacitor, under the unit's normal working conditions. The leakage-current should be less than 0.5 mA rms AC.

The resistance measurement should be done between accessible exposed metal parts and power cord plug prongs with the power switch (if included) "ON". The resistance should be more than 2.2 Mohms.

MAKE YOUR CONTRIBUTION TO PROTECT THE ENVIRONMENT

Used batteries with the ISO symbol for recycling as well as accumulators (rechargeable batteries), mini-batteries (cells) and starter batteries should not be thrown into the garbage can.



Please leave them at an appropriate depot. All other household batteries can be thrown out with the household waste.

★ INFORMATION

SYMBOLS FOR PRIMARY DESTINATION

Primary destinations of units are indicated with the following alphabet.

Symbols	Primary Destinations
B	UK
E	Europe (except UK)
S	Australia
V	Germany
U	Universal Area
Y*	Custom version

VOLTAGE CONVERSION (U Model only)

Before connecting the power cord, set the VOLTAGE SELECTOR located on the rear panel with a flat type screwdriver so that the correct voltage for your area is indicated.

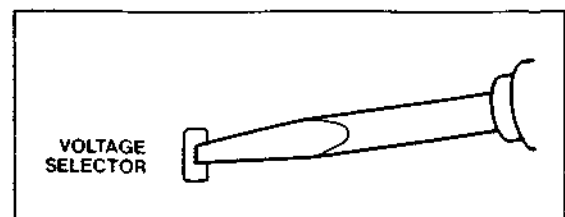

I. DISASSEMBLY

In case of trouble, etc., necessitating dismantling, please dismantle in the order shown in the illustrations. Reassemble in reverse order.

1. Removal of the UPPER COVER

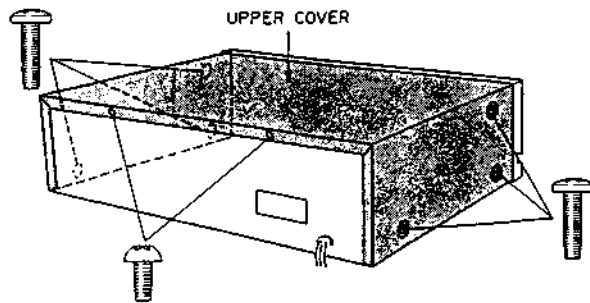

2. Removal of the CASSETTE LID

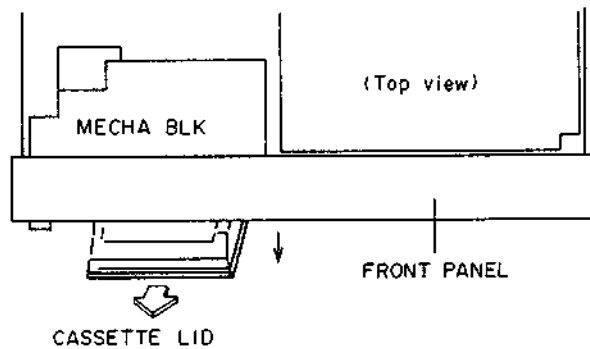

- 1) Turn the power ON and press the OPEN/CLOSE (▲) button to open the cassette lid. (GX-67 ONLY)
- 2) Press the EJECT button to open the cassette lid. (DX-57 ONLY)
- 3) Remove the cassette lid by pulling it in the direction of the arrow (↓).

3. Removal of the FRONT PANEL

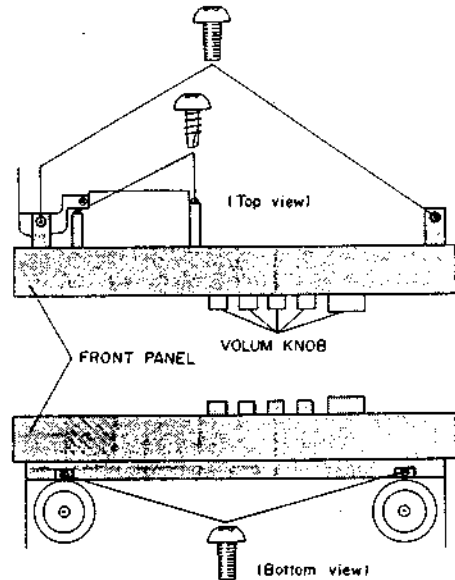

- 1) Remove the five knobs on the FRONT PANEL.
- 2) Remove the REC LEVEL volume retaining nut.
- 3) Disconnect the P104, P105, P106 and P107 connectors on the PRE AMP PCB.
- 4) Remove the FRONT PANEL retaining screws.

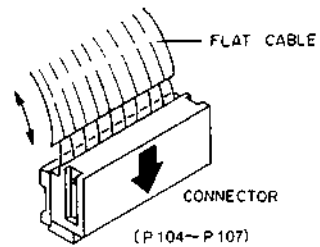

II. PRINCIPAL PARTS LOCATION

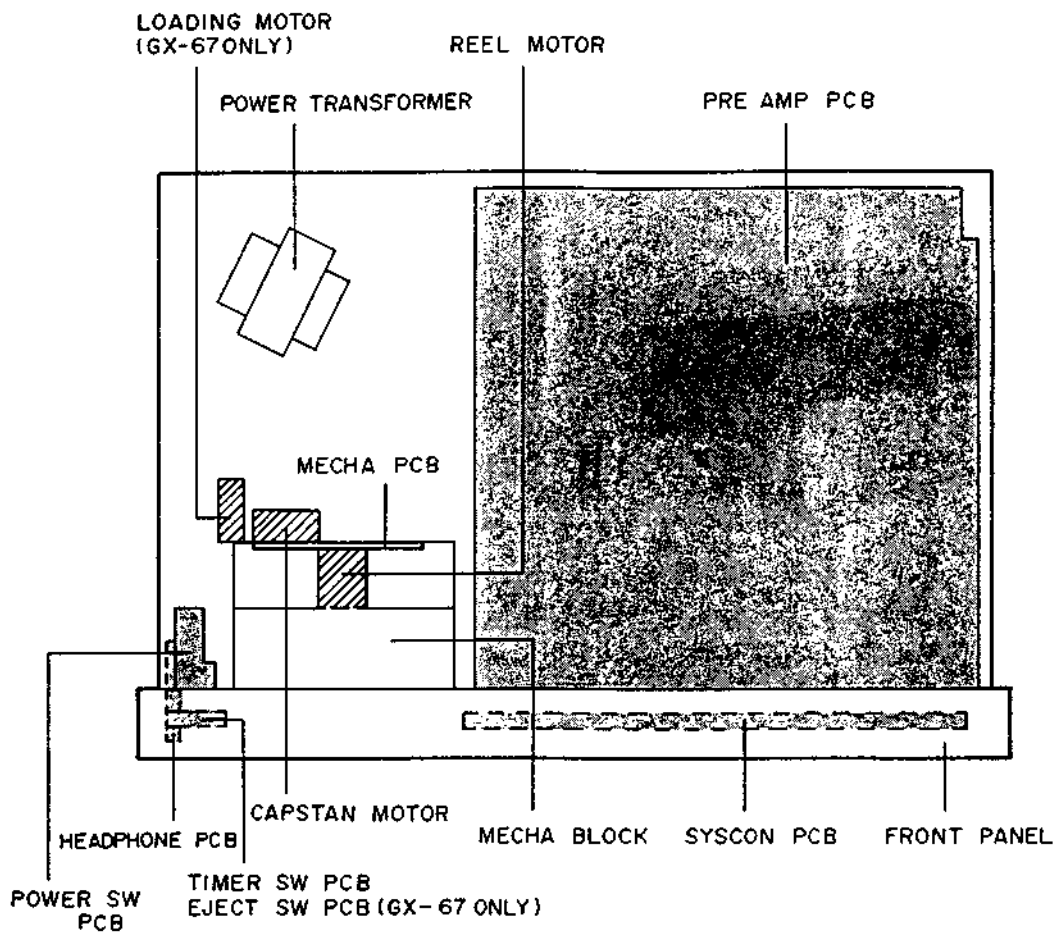
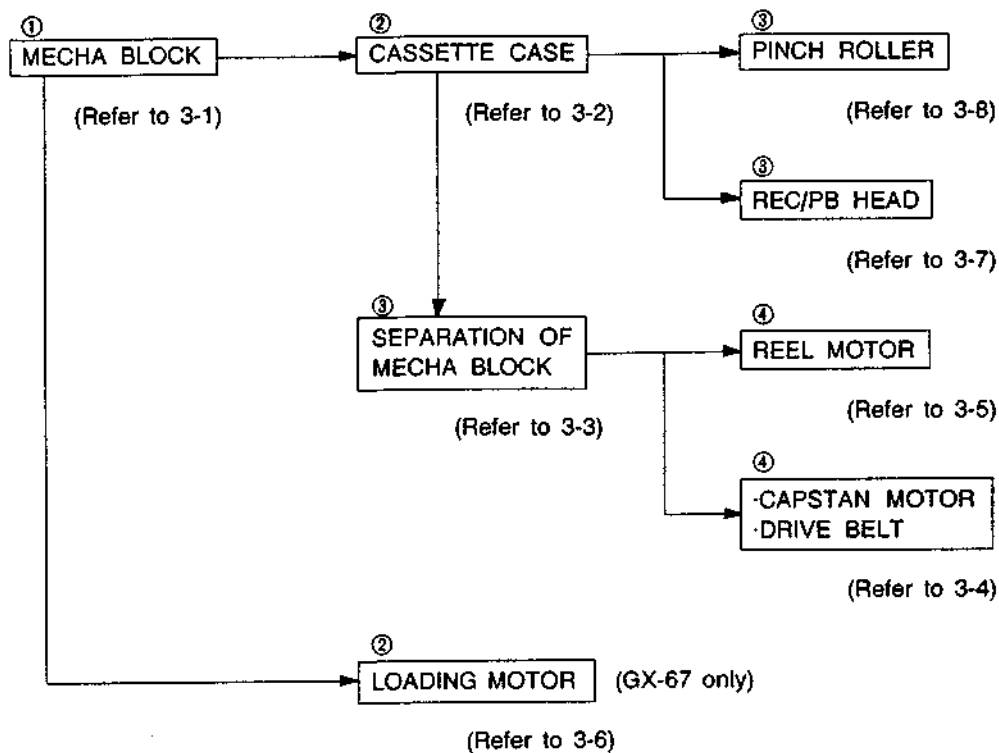

Fig. 2-1 Top view

III. REPLACEMENT OF THE PRINCIPAL COMPONENT

[DISMANTLING PROCEDURE OF THE COMPONENT]

When replacement of a mechanical part is necessary, replace the part using one of the following procedures.



3-1. HOW TO REMOVE THE MECHA BLOCK

- 1) Disconnect the two connectors on the MECHA BLOCK.
- 2) Disconnect the P101, P102, P103, P108, P109, P110 and P111 connectors on the PRE AMP PCB.
- 3) Remove the MECHA BLOCK retaining screws (A).
- 4) Remove the MECHA BLOCK retaining screws (B) and (C) of bottom side.
- 5) Remove the MECHA BLOCK.
- 6) Reassemble by replacing the parts in the reverse order of removal.

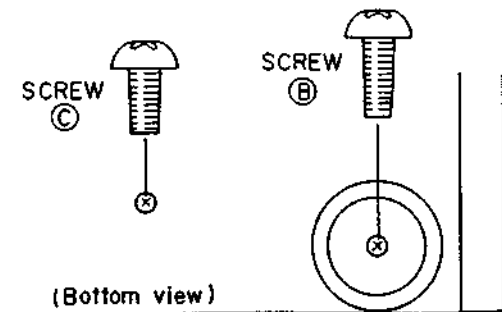

Fig. 3-1

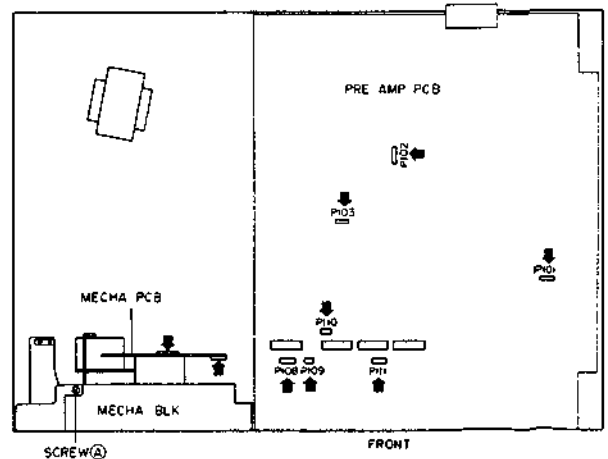

Fig. 3-2

3-2.HOW TO REMOVE THE CASSETTE CASE

- 1) Remove the spring ①.
- 2) Remove the lid arm from the cassette case.
- 3) Remove the pivot from the MECHA BLOCK.
- 4) Reassemble by replacing the parts in the reverse order of removal.

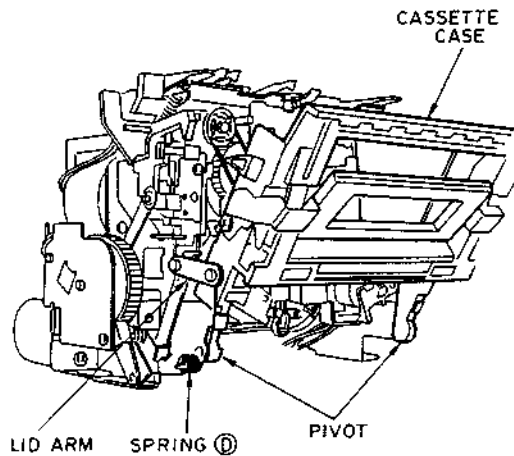

Fig. 3-3

3-3.SEPARATION OF THE MECHA BLOCK

- 1) Remove the capstan motor lead wires with a soldering iron.
- 2) Remove the stopper retaining screw ②.
- 3) Remove the MECHA BLOCK retaining screws ③.
- 4) Separate the REEL BLOCK and the CAPSTAN BLOCK of the MECHA BLOCK.
- 5) Reassemble by replacing the parts in the reverse order of removal.

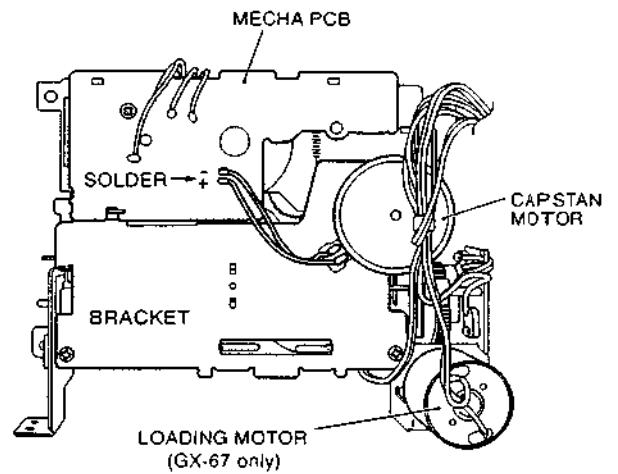

Fig. 3-4

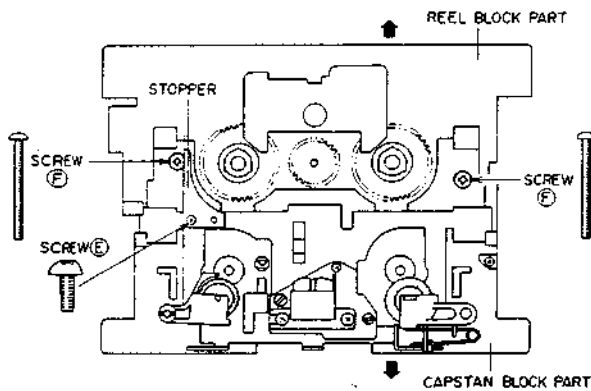

Fig. 3-5

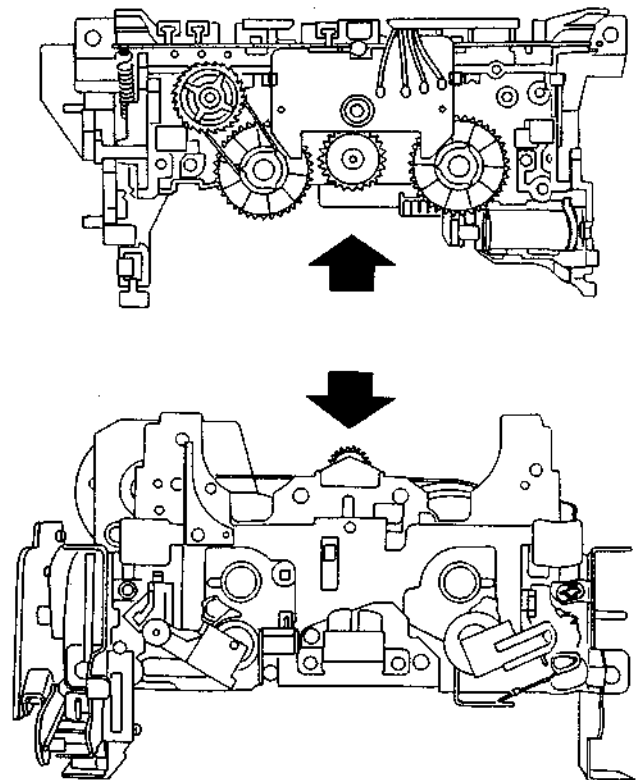

Fig. 3-6

3-4.REPLACEMENT OF THE CAPSTAN MOTOR AND DRIVE BELT

- 1) Remove the side plate retaining screw ③ and then remove the side plate.
- 2) Remove the bracket retaining screw ④ and then remove the bracket. (Refer to Fig.3-8).

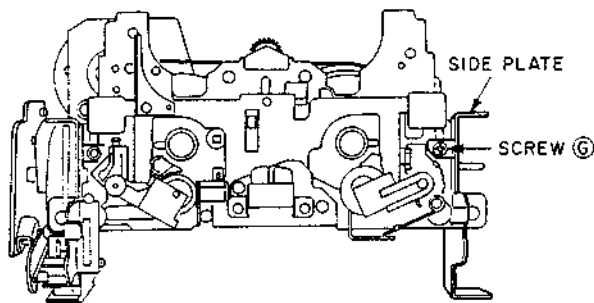

Fig. 3-7

3-4-1. HOW TO REMOVE THE CAPSTAN MOTOR

- 1) Remove the capstan motor retaining screw ①.
- 2) To reassemble, replace the retaining screw and connect the drive belt to the motor pulley.

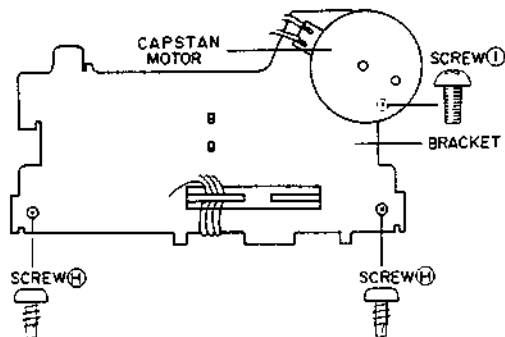

Fig. 3-8

3-4-2. HOW TO REMOVE THE DRIVE BELT

- 1) Remove the DRIVE BELT from the capstan wheel.
- 2) To reassemble, connect the DRIVE BELT to the capstan wheel and then connect it to the motor pulley.

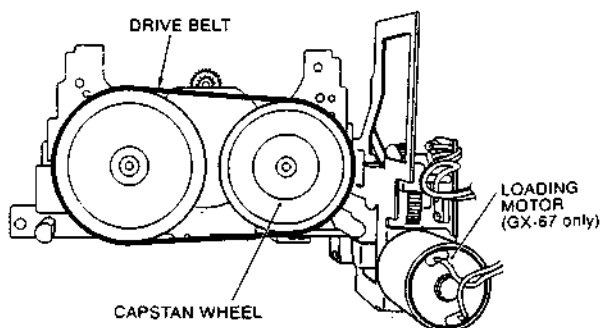

Fig. 3-9

3-5.REPLACEMENT OF THE REEL MOTOR

- 1) Remove the solder of all detector switches, lead wires from the solenoid and reel motor leads with a soldering iron.
- 2) Remove the PCB retaining screw ②.
- 3) Release the two hooks which retain the REEL PULSE DETECTION PCB and remove the PCB. (Refer to Fig.3-12)
- 4) Remove the springs of the assist lever (A) and (B).
- 5) Extract the assist lever (A) and (B).
- 6) Remove the reel motor retaining screws ⑤ and remove the REEL MOTOR.
- 7) Reassemble by replacing the parts in the reverse order of removal.

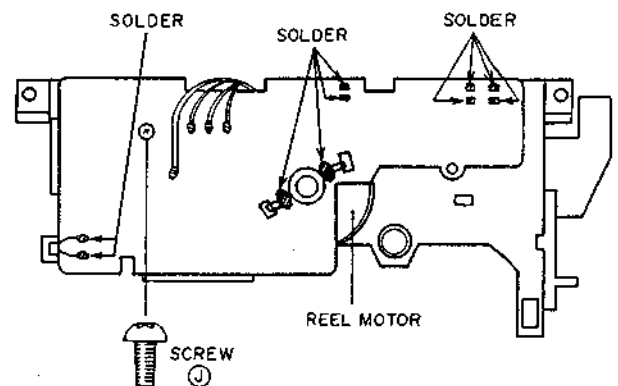

Fig. 3-10

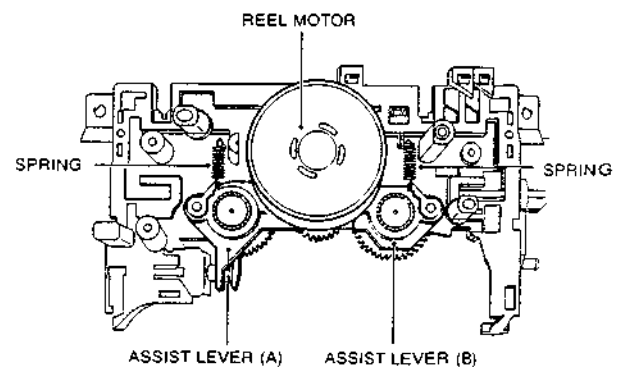

Fig. 3-11

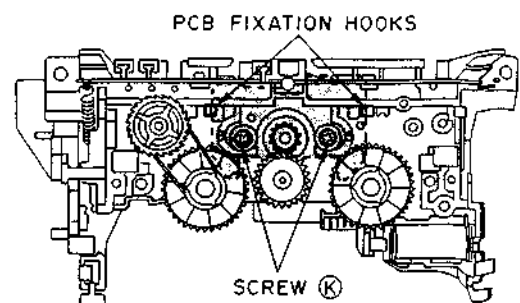

Fig. 3-12

3-6. REPLACEMENT OF THE LOADING MOTOR (GX-67 only)

- 1) Remove the holder (2) retaining screws (L) and then remove the holder (2).
- 2) Remove the LOADING MOTOR retaining screws (M) and remove the LOADING MOTOR.
- 3) Reassemble by replacing the parts in the reverse order of removal.

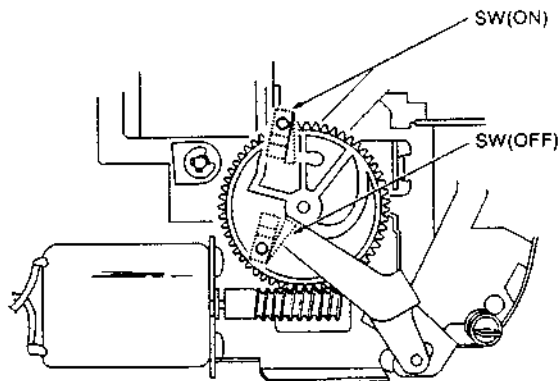

Fig. 3-14

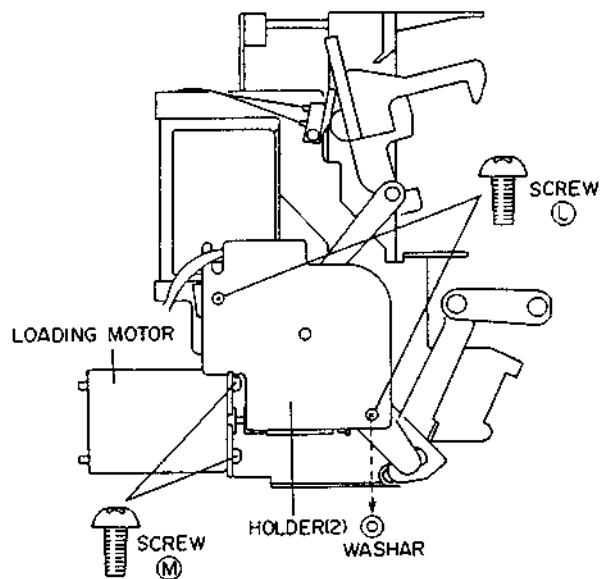
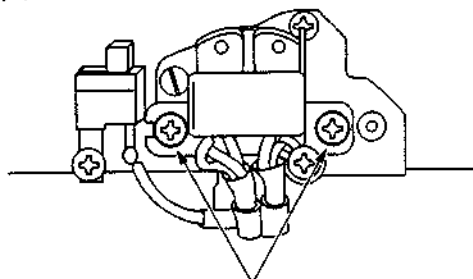

Fig. 3-13

3-7. REPLACEMENT OF THE REC/PB HEAD

- 1) Remove the head retaining screws (N).
- 2) Disconnect the lead wires with a soldering iron.
- 3) Reassemble by replacing the parts in the reverse order of removal.

- Never move the head height adjustment screws (N) and (D) in this step as they have been adjusted previously.
- After replacement, precise head adjustment is necessary (refer to 5. HEAD ADJUSTMENT).



SCREW (N)

Fig. 3-15

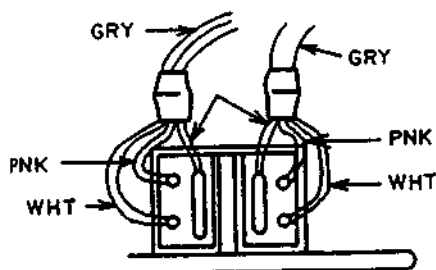

Fig. 3-16

3-8. REPLACEMENT OF THE PINCH ROLLER BLOCK

3-8-1. SUPPLY PINCH ROLLER BLOCK

- 1) Remove the tape guide (1) adjustment nut (A).
- 2) Extract the SUPPLY PINCH ROLLER BLOCK.
- 3) Reassemble by replacing the parts in the reverse order of removal.

[NOTE]

After reassembling the supply pinch roller block, step 5-1, "TAPE GUIDE HEIGHT ADJUSTMENT" must be performed.

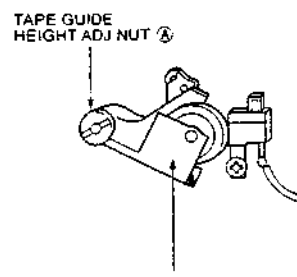

SUPPLY PINCH ROLLER BLOCK

Fig. 3-17

3-8-2. TAKE UP PINCH ROLLER BLOCK

- 1) Release the TAKE UP PINCH ROLLER BLOCK's retaining hook and extract the TAKE UP PINCH ROLLER BLOCK.
- 2) Reassemble by replacing parts in the reverse order of removal.

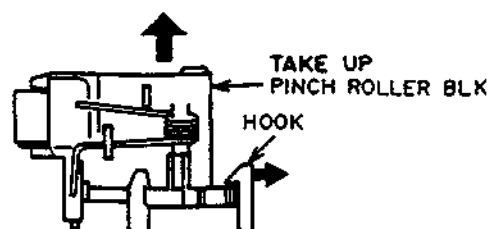

Fig. 3-18

IV.MECHANICAL ADJUSTMENT

4-1.CONFIRMATION OF PINCH ROLLER PRESSURE

- 1) Set the unit in the "PLAY" mode without a cassette tape loaded.
- 2) Push the TAKE UP PINCH ROLLER arm down 1 or 2 mm from the capstan with a spring gauge.

Release the pressure of the spring gauge little by little and read the scale at the moment when the TAKE UP PINCH ROLLER touches to the capstan and starts rotation.

Also confirm the SUPPLY PINCH ROLLER pressure with the same procedure as above.

Specified pinch roller pressure:

TAKE UP PINCH ROLLER : 320 ± 50 grams

SUPPLY PINCH ROLLER : 200 ± 40 grams

- If either of the PINCH ROLLER's pressure is not satisfactory, replace it.

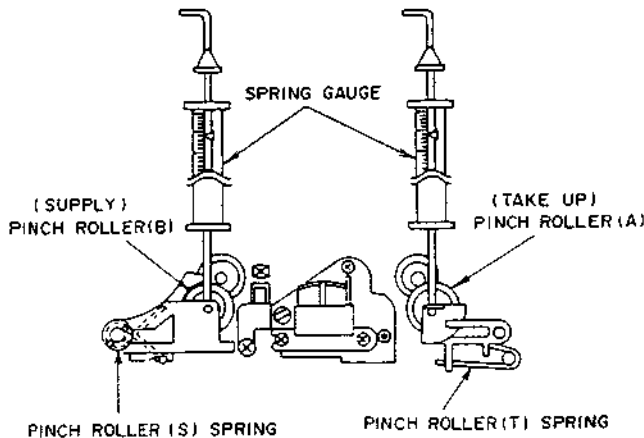

Fig. 4-1

4-2.CONFIRMATION OF WINDING TORQUE IN EACH MODE

- 1) Insert the CASSETTE TORQUE METER (AJ-751179).
- 2) Read the TORQUE METER in each mode. For fast forward and rewind, read at the end of the tape when the tape has stopped running.

PLAY mode

TAKE UP TORQUE : 35 to 55 grams

BACK TENSION : 5 to 10 grams

FF and RWD mode : 70 to 160 grams

CASSETTE TORQUE METER
(AJ751179)

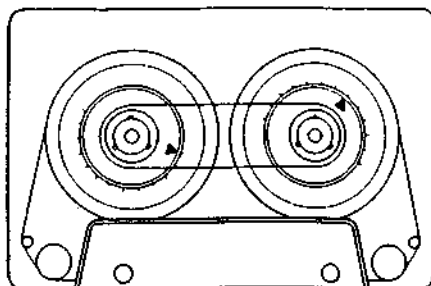

Fig. 4-2

4-3.TAPE SPEED ADJUSTMENT

- 1) Connect a frequency counter to the LINE OUT and play back a 3150 Hz test tape (AT-751263).
- 2) Insert a small flat screw driver into a hole on the capstan motor and adjust the tape speed control VR so that the reading on the frequency counter is 3150 ± 10 Hz.

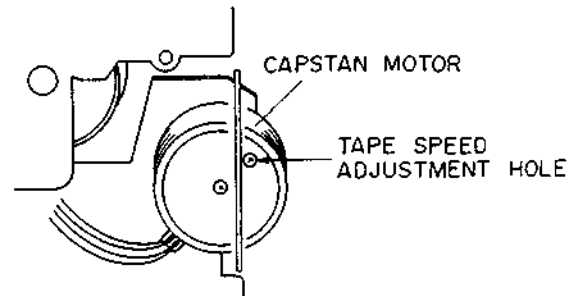

Fig. 4-3

4-4.HOW TO REMOVE A JAMMED CASSETTE TAPE

If a damaged tape or defective tape drive mechanism causes a cassette tape to be caught by the capstan, remove the tape from the mechanism block using the following procedure.

- 1) Place your index finger under the mechanism block and turn the capstan wheel (take up side) counterclockwise until the jammed tape loosens.
- 2) Press the EJECT button. (DX-57 only)
- 3) Disconnect the LOADING MOTOR'S P110 connector from the PRE AMP PCB. (GX-67 only)
- 4) Connect a 4.5 V battery onto the LOADING MOTOR and eject the tape. (GX-67 only)

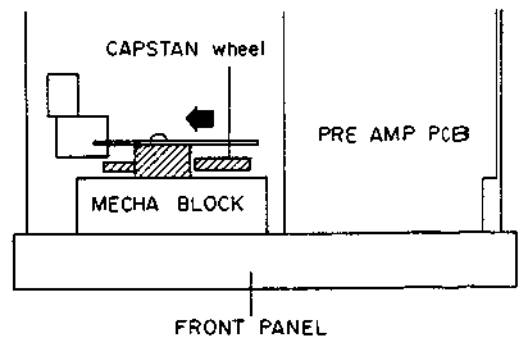

Fig. 4-4

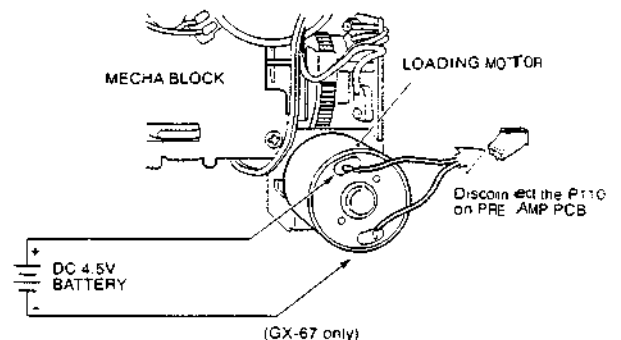

Fig. 4-5

V. HEAD ADJUSTMENT

5-1. TAPE GUIDE HEIGHT ADJUSTMENT

* Caution:

The tape guide adjustment nut (A) is important as it fixes the position of the tape guide (1) and has been precisely adjusted at the factory.

Never turn this nut unless it is absolutely necessary (when replacing the SUPPLY PINCH ROLLER BLOCK for example).

- 1) Load the mirror cassette tape (AJ-751178) and engage the PLAY mode.
- 2) Pre-adjust the tape guide adjustment nut (A) so that the tape runs smoothly and the edge of the tape is not curled or wrinkled at the TAPE GUIDE (1) or TAPE GUIDE (2).

- 3) Load the 10 kHz head azimuth test tape (AT-750778) and play it back.

Adjust the tape guide adjustment nut (A) precisely so that the line output level is maximum and also confirm that the edge of the tape is not curled or wrinkled at both the tape guides.

- 4) After the adjustment is completed, lock the tape guide adjustment nut (A) with lock-paint.

5-2. REC/PB HEAD AZIMUTH ALIGNMENT ADJUSTMENT

- 1) Load the 10 kHz head azimuth test tape (AT-750778) and play it back.
- 2) Turn the azimuth adjust screw (B) so that both the left and right channel line output levels are maximum and in the same phase.
- 3) After the adjustment is completed, lock the azimuth adjust screw (B) with lock-paint.

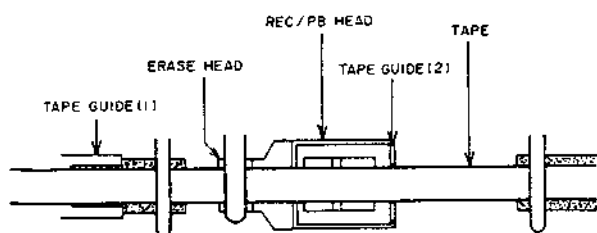

Fig.5-1

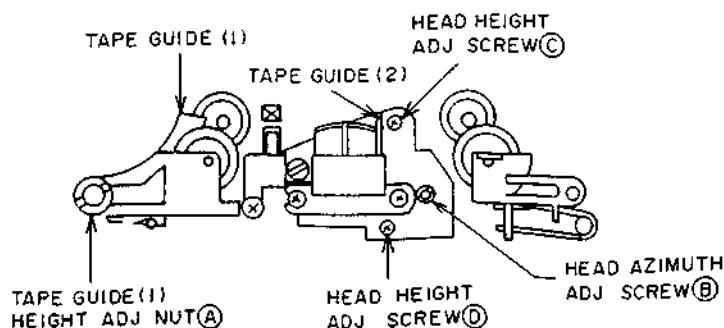

Fig.5-2

5-3. ADJUSTMENT WHEN THE REC/PB HEAD IS REPLACED

- 1) Load the mirror cassette tape (AJ-751178) and engage the PLAY mode, confirming that the edge of the tape is not curled or wrinkled at the TAPE GUIDE (2).

[When the tape is running smoothly]

- A) Perform the REC / PB HEAD azimuth adjustment (refer to 5-2).

- B) Play back the 1000 Hz (4 track) head height adjustment test tape (AT-750775) and confirm that the LINE OUTPUT level is maximum (-6 dBs).

[When the tape is not running smoothly]

- A) Play back the mirror cassette test tape and observe the TAPE GUIDE (2),

checking to see whether its height is too low or too high.

- B) Loosen the azimuth adjust screw (B) and pre-adjust the head height adjustment screws (C) and (D).

NOTE

Always turn the (C) and (D) screws in the same direction and to the same degrees.

- When the head height is too low : Turn clockwise.
- When the head height is too high : Turn counterclockwise.

(The head height adjust screws (C) and (D) can not be adjusted during playback.)

- C) Play back the mirror cassette tape and check the TAPE GUIDE (2) height again.

- D) Repeat the above steps B) and C) until results are satisfactory.

- E) Play back the 10 kHz head azimuth test tape and finely adjust the tape guide adjustment nut (A) so that the LINE OUTPUT level is maximum.

- F) Play back the 1000 Hz (4 track) head height adjust test tape and confirm that the LINE OUTPUT level is maximum (-6 dBs).

- Move the REC / PB HEAD up or down slightly during playback, and if the level increases, re-adjust the head height adjustment screws (C) and (D).

- G) After the above adjustments are completed, adjust the head azimuth again (Refer to step 5-2).

- H) Lock the head height adjustment screws (C) and (D) with lock-paint after all the adjustments are satisfactorily completed.

VI. ELECTRICAL ADJUSTMENT

NOTES

- All adjustments should be made with CAL, DOLBY and MPX FILTER switches OFF (except STEP 4,11)
- Control settings
 - REC LEVEL : Maximum
 - REC BALANCE : Center click position
 - CALIBRATION LEVEL : Center click position (GX-67 only)
 - CALIBRATION BIAS : Center click position (GX-67 only)
 - BIAS : Center click position (DX-57 only)
- Use the following cassette tapes for adjustment.
 - NORMAL TAPE : MAXELL UD1 C-60
 - CrO₂ TAPE : TDK SA C-60
 - METAL TAPE : TDK MA C-60

ADJUSTMENT KEY

STEP No.	ADJUSTMENT ITEM
1.	TEST tape / Supply signal
2.	MODE
3.	Adjustment Parts / Adjustment point
4.	(•) Remarks / (*) Result

7	NORMAL POSITION BIAS
1.	NORMAL recording tape / 1 kHz, 12.5 kHz, Set AUDIO signal generator output control so that the LINE OUTPUT level is - 28.5 dBs
2.	REC / PLAY (⏪ → ▶), PLAY (▶)
3.	VR 323 (Lch), VR 423 (Rch) / LINE OUTPUT
4.	• Connect the AC milli-voltmeters to LINE OUT * - 28.5 dBs (1 kHz, 12.5 kHz) flat

8	CrO ₂ POSITION BIAS
1.	CrO ₂ recording tape / 1 kHz, 12.5 kHz, Set AUDIO signal generator output control so that the LINE OUTPUT level is - 28.5 dBs
2.	REC/PLAY (⏪ → ▶), PLAY (▶)
3.	VR 322 / LINE OUTPUT
4.	• Connect the AC milli-voltmeters to LINE OUT * - 28.5 dBs (1 kHz, 12.5 kHz) flat

9	METAL POSITION BIAS
1.	METAL recording tape / 1 kHz, 12.5 kHz, Set AUDIO signal generator output control so that the LINE OUTPUT level is - 28.5 dBs
2.	REC/PLAY (⏪ → ▶), PLAY (▶)
3.	VR 321 / LINE OUTPUT
4.	• Connect the AC milli-voltmeters to LINE OUT * - 28.5 dBs (1 kHz, 12.5 kHz) flat

2	ERASE / BIAS FREQUENCY
1.	METAL recording tape
2.	REC / PLAY (⏪ → ▶)
3.	T 322 / P103
4.	• Connect a frequency counter to P103 (① / ②) * 105 ± 0.2 kHz

4	MPX FILTER
1.	19 kHz, Set AUDIO signal generator output control so that the LINE OUTPUT level is - 6.0 dBs
2.	STOP / SOURCE MONITOR
3.	FL 171 (Lch), FL 271 (Rch) / LINE OUTPUT
4.	• MPX sw ON • Connect the AC voltmeters to LINE OUTPUT * Minimum level (Less then - 36 dBs)

11	CAL METER (GX-67 only)
1.	CrO ₂ recording tape
2.	CAL SW ON, REC/PLAY (⏪ → ▶)
3.	VR 181 (CAL LEVEL), VR 281 (CAL BIAS) / on FLD (VU meter)
4.	• Adjustment must be made just before the 0 dB segment lights completely

3	BIAS DIP POINT
1.	METAL recording tape
2.	REC/PLAY (⏪ → ▶)
3.	T 321 (Lch), T 421 (Rch) / TP-1 and TP-2
4.	• Connect the DC milli-voltmeter between TP-1 (+) and TP-2 (-) * Minimum DC voltage

1	METER LINEARITY
1.	400 Hz, Set AUDIO signal generator output control so that the LINE OUTPUT level is - 23.0 dBs.
2.	STOP/SOURCE MONITOR
3.	VR 311 / on FLD (VU meter)
4.	• Adjustment until the - 20 dB indicator lights completely

10	RECORDING LEVEL
1.	NORMAL recording tape / 315 Hz, Set AUDIO signal generator output control so that the LINE OUTPUT level is - 6.0 dBs
2.	REC/PLAY (⏪ → ▶), PLAY (▶)
3.	VR 171 (Lch), VR 271 (Rch) / LINE OUTPUT
4.	• Connect the AC milli-voltmeters to LINE OUT * - 6.0 dBs

5	PLAYBACK LEVEL
1.	315 Hz TEST tape (AT750773)
2.	PLAY (▶)
3.	VR 101 (Lch), VR 201 (Rch) / LINE OUTPUT
4.	• Connect the AC milli-voltmeters to LINE OUT * - 6.0 dBs

6	PLAYBACK EQUALIZER LEVEL
1.	10 kHz (-15 dB) TEST tape (AT750778)
2.	PLAY (▶)
3.	VR 102 (Lch), VR 202 (Rch) / LINE OUTPUT
4.	• Connect the AC milli-voltmeters to LINE OUT * - 21.0 dBs

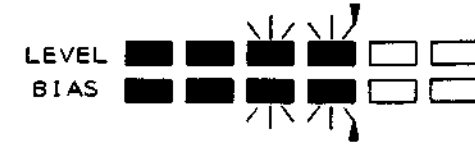
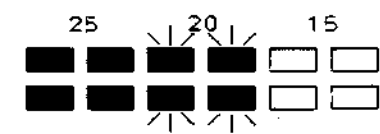
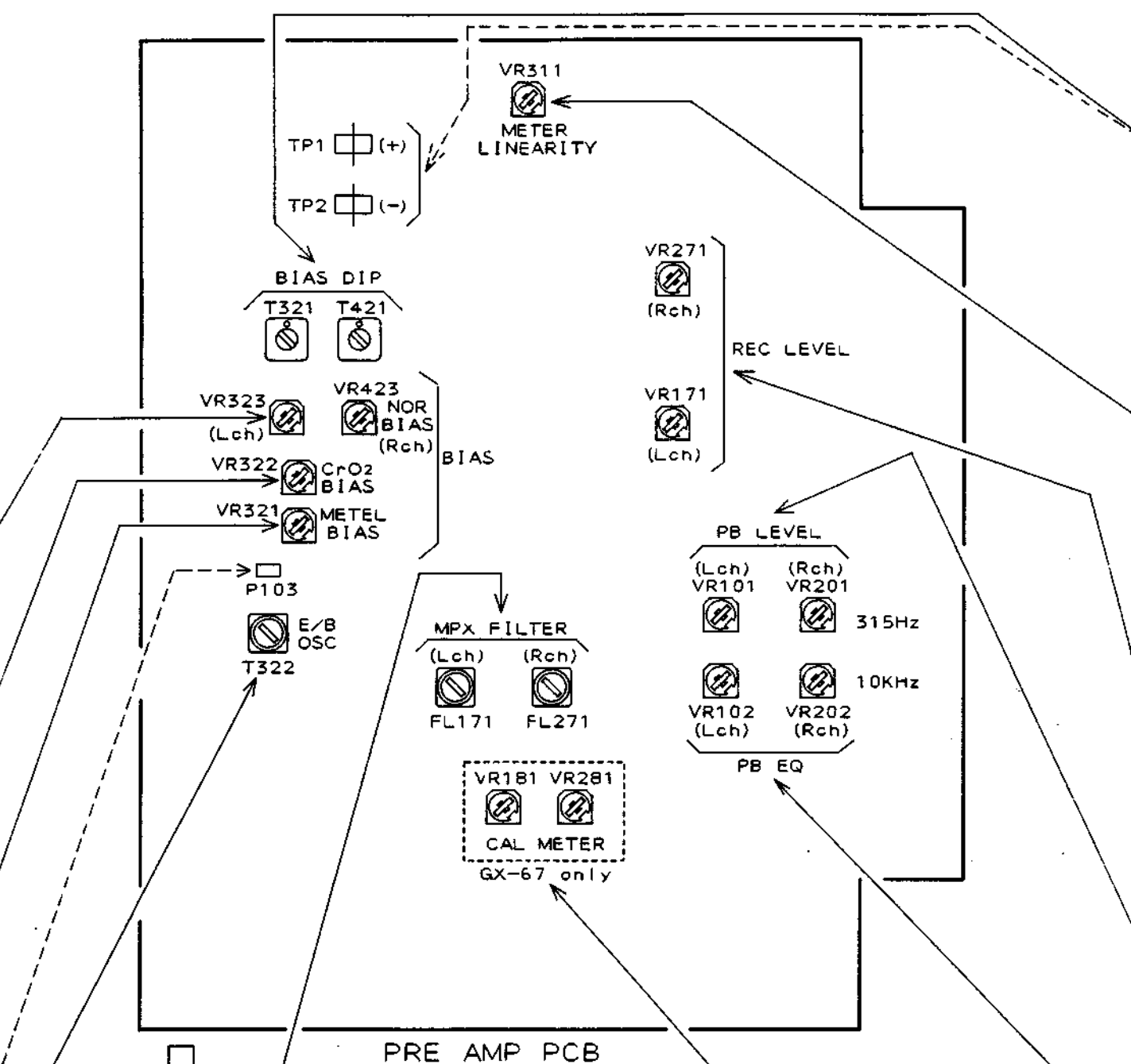

VII. PARTS LIST

ATTENTION

1. When placing an order for parts, be sure to list Part No., Model No. and the description of each part. Otherwise, the non-delivery of the part or the delivery of a wrong part may result.
2. Please make sure that Part No. is correct when ordering. If not, a part different from the one you ordered may be delivered.
3. Since the parts shown in Parts List of Preliminary Service Manual may have been the subject of changes, please use this Parts List for all future reference.

HOW TO USE THIS PARTS LIST

1. This Parts List lists those parts which are considered necessary for repairs. Other common parts, such as resistors and capacitors, are listed in the "Common List for Service Parts" from which these parts should be selected and stocked.
2. The Recommended Spare Parts List shows those parts in the Parts List which are considered particularly important for service.
3. Parts not shown in the Parts List and "Common List for Service Parts" will not in principle be supplied.
4. How to read the Parts List.
 - a) Mechanism Block

2. HEAD BASE BLOCK

Ref. No.	Part No.	Description
1	BH-T2023A320A	HEAD BASE BLOCK
2	HP-H2206A010A	HEAD R/P PR4-8FU C
3	ZS-477876	PAN20x03STL CMT
4	ZS-536488	BID20x08STL CMT
5	ZG-402895	SP CS ANGLE ADJUST

SP (Service Parts) Classification
This number corresponds with the individual parts index number in that figure.

b) PC Board

6. MAIN PC BOARD

Ref. No.	Part No.	Description
IC1	EI-324536	IC HD14049BP
IC2	EI-336801	IC MB8841-564M
C1A	EC-338399	C MMY V 223M 250AC [U,E,B,S]
C1B	EC-350949	C MMY V 223M 250DC [J]
C1C	EC-338397	C MMY V 223M 125AC [C,A]
X1	EI-318384	OSC XTAL NC-18C

Symbols for primary destination
[A]: AAL (U.S.A) [S]: SAA (Australia)
[B]: BEAB (England) [U]: U/T (Universal Area)
[C]: CSA (Canada)
[E]: CEE (Europe) [V]: VDE (Germany)
[J]: JPN (Japan) [Y]: Custom Version

SP (Service Parts) Classification
These reference symbols correspond with component symbols in the Schematic Diagrams.

The available PC Board Blocks are listed separately.

5. When Part No. is known, Parts Index at end of Parts List can be used to locate where that part is shown in Parts List by its Reference No. listed at right of Part No.

WARNING

Δ (*) INDICATES SAFETY CRITICAL COMPONENTS. FOR CONTINUED SAFETY, REPLACE SAFETY CRITICAL COMPONENTS ONLY WITH MANUFACTURER'S RECOMMENDED PARTS.

AVERTISSEMENT

Δ (*) IL INDIQUE LES COMPOSANTS CRITIQUES DE SÉCURITÉ. POUR MAINTENIR LE DEGRÉ DE SÉCURITÉ DE L'APPAREIL, NE REMPLACER QUE DES PIÈCES RECOMMANDÉES PAR LE FABRICANT.

1. RECOMMENDED SPARE PARTS

We suggest you to stock the following Recommended Spare Part items listed below since they can cover most of the routine service.

Ref.No.	Part No.	Description
1	AX-D4004A010B	REMOCON BLK RC-G57 [DX-57]
2	AX-D4004A010A	REMOCON BLK RC-G67 [GX-67]
3	BB-T2130A050B	MECHA BLK DX-57 [DX-57]
4	BB-T2130A050A	MECHA BLK GX-67 [GX-67]
5	*BT-391564J	TRANS POW T2118 BS [B,S]
6	*BT-391561J	TRANS POW T2118 U [U]
7	*BT-405379J	TRANS POW T2130 E [E]
8	ED-307572	D SILICON H 1S5131
9	ED-624903	D SILICON H 1S2473 [GX-67]
10	*ED-405583J	D SILICON RL202BB81 F08 100/2A [B]
11	*ED-511907	D SILICON 1N4002 100/1.0A [EXCEPT B]
12	ED-400221J	D ZENER H HZ11A3LFA F10
13	ED-346574	D ZENER H HZ22-2L
14	ED-346598	D ZENER H HZ4 C2
15	*ED-346602	D ZENER H HZ5 B3
16	ED-343410	D ZENER H HZ6A1L
17	*ED-346525	D ZENER H HZ6A3L
18	ED-351419	D ZENER H HZ7B3L
19	ED-346536	D ZENER H HZ7C3L [GX-67]
20	ED-346541	D ZENER H HZ9B2L
21	*EF-358641	FUSE BET T 250V 800MA [E,B,S]
22	*EF-309387	FUSE TSC A 250V 1.00A [U]
23	EH-370972	FILTER LC LP 370972
24	EI-367572	IC BA15218
25	EI-373980	IC BA15218N
26	EI-353421	IC BA6229 [GX-67]
27	EI-384868J	IC BU4030B
28	EI-394573J	IC CXA1331S
29	EI-394574J	IC LA2000
30	EI-405498J	IC M50941-627SP 91DECK2
31	EI-360043	IC M5220P
32	EI-310036	IC TC4066BP
33	EI-373383	IC UPC1297CA
34	*EI-377101	IC UPC7805HF
35	EI-405327J	OSC CE CST6.00MGW 6.000MHZ
36	EM-405274J	IND FL CM1068C DOUBLE
37	EO-361292	COIL FIX 1 RC875 682J [GX-67]
38	EO-405355J	COIL FIX 3 E1222T472J 472J222J
39	EO-389245J	COIL OSC 1 T2118 100.0KHZ
40	EO-400766J	COIL OSC 1 T2128 (HX) -7 200KHZ [GX-67]
41	EO-405296J	COIL OSC 1 T2130 (HX) 105KHZ [DX-57]
42	EO-405356J	COIL TUN 1 105Z391S 105KHZ [DX-57]
43	EO-405304J	COIL TUN 1 210Z181S [GX-67]
44	*ER-320528	R FUSE H ERD2FC 1/4W 22R0G
45	*ER-401039J	R FUSE V T05 ERD2FCV 1/4W 4R7J
46	*ES-371104	SW PUSH SDDL1 01-1 [POWER SW]
47	ES-405302J	SW PUSH SPUY32 3THROW N [DX-57]
48	ES-405295J	SW PUSH SPUY42 4THROW N [GX-67]
49	ES-370965	SW SLIDE SSSU02 1-01-03N
50	ES-396610J	SW TACT SOR-122HS T05 [REW]
51	ET-403246J	DETECTOR HC-377

Ref.No.	Part No.	Description
52	ET-396487J	TR DTA124XL T05
53	ET-371075	TR DTA124XS
54	ET-373382	TR DTA143ZS
55	ET-354415	TR DTA144ES
56	ET-360399	TR DTC114TS
57	ET-354365	TR DTC114YS
58	ET-354371	TR DTC124ES
59	ET-354364	TR DTC143TS
60	ET-405594J	TR DTC143ZL T05
61	ET-373391	TR DTC143ZS
62	ET-396488J	TR DTC144EL T05
63	ET-354414	TR DTC144ES [GX-67]
64	ET-370310	TR DTC144TS
65	ET-347738	TR 2SA1282A E,F F05
66	ET-364093	TR 2SA1283 E,F
67	ET-352726	TR 2SA1392 T,U
68	ET-389803J	TR 2SA933S R,S
69	ET-400218J	TR 2SC1740S R,S
70	ET-365394	TR 2SC3242A E,F,G F05
71	ET-378524J	TR 2SC3383 S,T,U
72	ET-400741J	TR 2SC3708 T T05
73	ET-396072J	TR 2SD2159 V,W
74	EV-405297J	VR RK14K12B0 SPL C1253X2 [GX-67]
75	EV-405298J	VR ROTARY RK11K1120 B102
76	EV-405300J	VR ROTARY RK11K1120 SP W254
77	EV-405301J	VR ROTARY RK14K12B0 A503X2
78	EV-405299J	VR ROTARY RK16312A0 A104X2

MECHA BLOCK

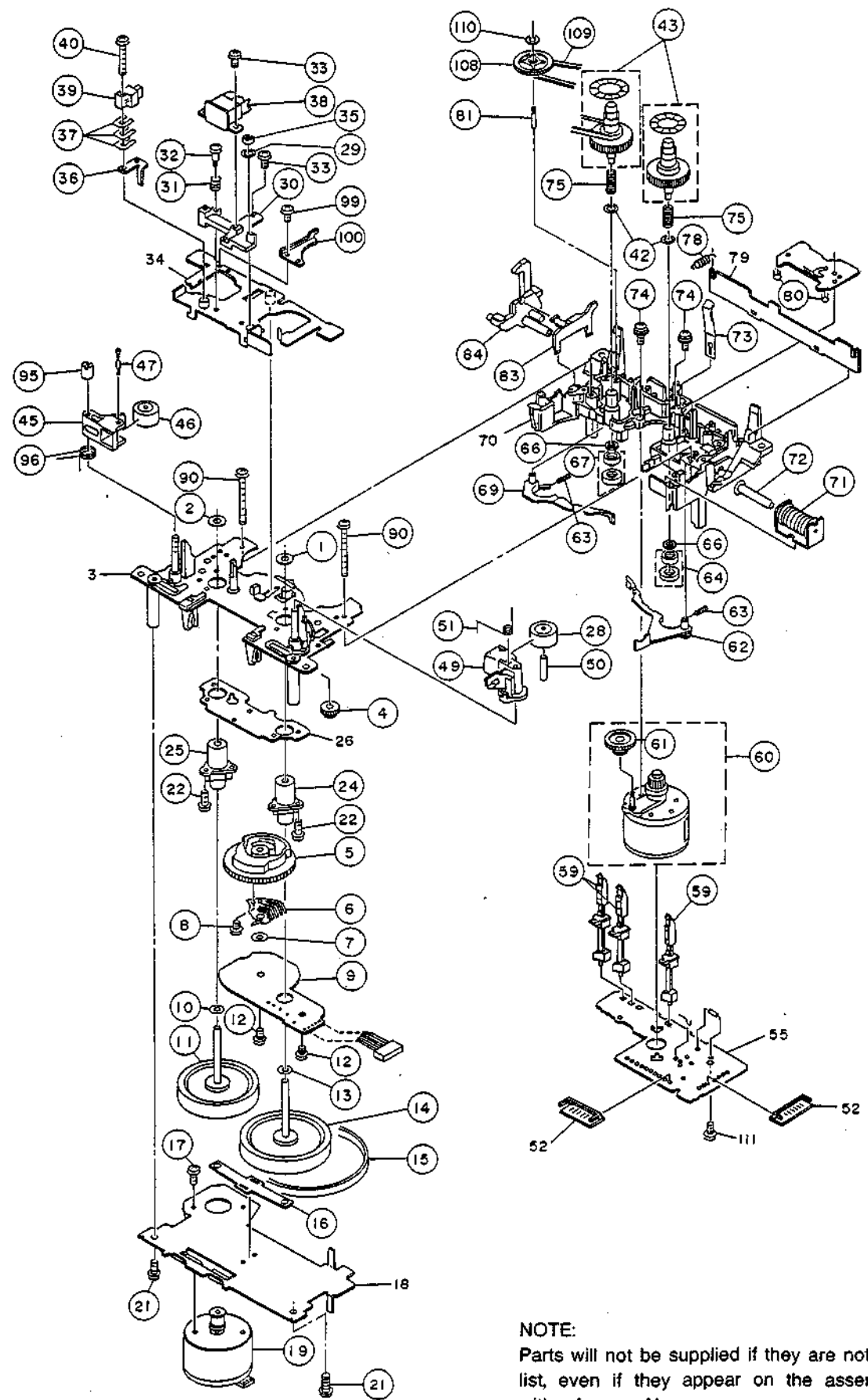

NOTE:
Parts will not be supplied if they are not listed in the parts list, even if they appear on the assembling illustrations with reference No.

2. MECHA BLOCK

Ref.No.	Part No.	Description
1	ZW-729545J	TW25
2	ZW-729440J	TW22
4	MZ-729441J	GEAR ASSIST
5	MZ-729442J	CAM
6	ES-729443J	SW ROTARY
7	ZW-729444J	WASHER 30X080X050 PSL
8	ZS-729445J	PAN 20X03
9	EA-732798J	PC CONTROL
10	ZW-732799J	WASHER
11	MI-732800J	FLYWHEEL
12	ZS-729449J	PAN 20X30
13	ZW-732801J	WASHER 26X047X050 PSL
14	MI-729453J	FLYWHEEL
15	MB-729451J	BELT CAPSTAN
16	MZ-729452J	HOLDER THRUST
17	ZS-729454J	PAN 26X03
19	BM-732802J	MOTOR CAPSTAN SHE2L55
21	ZS-729456J	SCREW TAPPING 26X08
22	ZS-729457J	ST PAN 20X08
24	MV-729458J	MAIN CASE (R)
25	MV-729459J	MAIN CASE (L)
28	MP-732803J	PINCH ROLLER
29	ZW-732819J	WASHER
30	HZ-732804J	BASE HEAD
31	ZG-729462J	SP AZIMUTH
32	MS-729463J	SHAFT
33	ZS-732805J	ST PAN 20X04
35	ZW-729466J	NUT ADJ
36	HZ-729467J	BASE E HEAD
37A	ZW-729468J	SPACER
37B	ZW-729465J	SPACER
37C	ZW-729546J	SPACER
38A	HR-H2411A010A	HEAD COMB RP4-10TG2 RP4-10TG2 [GX-67]
38B	HR-405284J	HEAD COMBO H2381 [DX-57]
39	HE-729469J	HEAD E 876-30-03
40	ZS-729470J	BID 20X12
42	ZW-732820J	WASHER
43	MT-732806J	REEL TABLE
45	ML-732807J	ARM PINCH ROLLER (S)
46	MP-732808J	PINCH ROLLER
47	MS-732809J	SHAFT PINCH ROLLER
49	ML-732810J	ARM PINCH ROLLER (R)
50	MS-729475J	SHAFT PINCH ROLLER
51	ZG-732811J	SP ARM PINCH ROLLER (R)
59	ES-729477J	LEAF SW
60	BM-732812J	MOTOR REEL PART SGE09014
61	MZ-729479J	GEAR IDLER
62	ML-729480J	LEVER ASSIST (A)
63	ZG-732813J	SP LEVER ASSIST
64	MR-729482J	PULLEY BRAKE (T) PART (WH)
66	ZW-729483J	WASHER 26X055X013 (PSL)
67	MR-729484J	PULLEY BRAKE (S) PART (BK)
69	ML-732814J	LEVER ASSIST (B)
71	EP-729487J	SOLENOID
72	MS-729488J	SHAFT SOLENOID
73	ZG-732815J	SP PLATE CASSETTE HOLDER [DX-57]
74	ZS-729490J	SCREW SPECIAL 26X016
75	ZG-729491J	SP REEL TABLE
78A	ZG-732816J	SP PULL CASSETTE PLATE [GX-67]
78B	ZG-729494J	SP PULL CASSETTE PLATE [DX-57]
80	ET-729496J	TR PHOTO NJL5181KF1 B
81	MS-729497J	SHAFT PULLEY
83	ML-729498J	LEVER
84	ML-729499J	LEVER EJECT
90	ZS-729500J	PAN 26X30
95	ZS-729501J	SCREW ADJ ARM PINCH ROLLER
96	ZG-729502J	SP PINCH ROLLER (S)
99	ZS-729503J	PAN 20X025
100	MZ-729504J	STOPPER
108	MR-729505J	PULLEY PART
109	MB-732817J	BELT
110	ZW-729507J	WASHER

3. P.C BOARD BLOCK

Ref.No.	Part No.	Description
1A	BA-T2130A020B	PC (#) PREAMP BLK GX-67 (U) [U,E,S]
1B	BA-T2130A020C	PC (#) PREAMP BLK GX-67 (B) [B]
1C	BA-T2130A020E	PC (#) PREAMP BLK DX-57 (U) [U,E,S]
1D	BA-T2130A020F	PC (#) PREAMP BLK DX-57 (B) [B]
2A	BA-T2130A030A	PC (#) SYSCON BLK GX-67
2B	BA-T2130A030B	PC (#) SYSCON BLK DX-57

PC (#) PRE AMP BLK CONSISTS OF FOLLOWING P.C BOARD.

- PRE AMP P.C BOARD
- HEAD PHONE P.C BOARD
- POWER SW P.C BOARD

PC (#) SYSCON BLK CONSISTS OF FOLLOWING P.C BOARD.

- SYSCON P.C BOARD
- TIMER SW P.C BOARD
- EJECT SW P.C BOARD

4. PRE AMP P.C BOARD

Ref.No.	Part No.	Description
D301	ED-624903	D SILICON H 1S2473 [GX-67]
D302	ED-624903	D SILICON H 1S2473 [GX-67]
D311	ED-624903	D SILICON H 1S2473
D411	ED-624903	D SILICON H 1S2473
D501	ED-624903	D SILICON H 1S2473
D502	ED-624903	D SILICON H 1S2473
D503	ED-346536	D ZENER H HZ7C3L [GX-67]
D504	ED-351419	D ZENER H HZ7B3L
D505	ED-346598	D ZENER H HZ4 C2
D506	ED-624903	D SILICON H 1S2473
D507	ED-624903	D SILICON H 1S2473
D508	ED-624903	D SILICON H 1S2473
D509	ED-624903	D SILICON H 1S2473
D801A	*ED-511907	D SILICON 1N4002 100/1.0A [EXCEPT B]
D801B	*ED-405583J	D SILICON RL202BB81 F08 100/2A [B]
D802A	*ED-511907	D SILICON 1N4002 100/1.0A [EXCEPT B]
D802B	*ED-405583J	D SILICON RL202BB81 F08 100/2A [B]
D803A	*ED-511907	D SILICON 1N4002 100/1.0A [EXCEPT B]
D803B	*ED-405583J	D SILICON RL202BB81 F08 100/2A [B]
D804A	*ED-511907	D SILICON 1N4002 100/1.0A [EXCEPT B]
D804B	*ED-405583J	D SILICON RL202BB81 F08 100/2A [B]
D805	ED-346541	D ZENER H HZ9B2L
D806	ED-346541	D ZENER H HZ9B2L
D807	ED-511907	D SILICON 1N4002 100/1.0A
D808	ED-511907	D SILICON 1N4002 100/1.0A
D809	ED-511907	D SILICON 1N4002 100/1.0A
D810	*ED-346525	D ZENER H HZ6A3L
D811	ED-400221J	D ZENER H HZ11A3LFA F10
D812	ED-511907	D SILICON 1N4002 100/1.0A
D813	ED-511907	D SILICON 1N4002 100/1.0A
D814	*ED-511907	D SILICON 1N4002 100/1.0A
D815	ED-343410	D ZENER H HZ6A1L
D816	ED-511907	D SILICON 1N4002 100/1.0A
D817	ED-511907	D SILICON 1N4002 100/1.0A
D818	ED-346574	D ZENER H HZ22-2L
D819	*ED-346602	D ZENER H HZ5 B3
D820	ED-511907	D SILICON 1N4002 100/1.0A
D821	ED-624903	D SILICON H 1S2473

Ref.No.	Part No.	Description
D822	ED-624903	D SILICON H 1S2473
D823	ED-624903	D SILICON H 1S2473
D824	ED-511907	D SILICON 1N4002 100/1.0A
FL101	EO-405304J	COIL TUN 1 210Z181S [GX-67]
FL141A	EO-405304J	COIL TUN 1 210Z181S [GX-67]
FL141B	EO-405356J	COIL TUN 1 105Z391S 105KHZ [DX-57]
FL171	EH-370972	FILTER LC LP 370972
FL201	EO-405304J	COIL TUN 1 210Z181S [GX-67]
FL241A	EO-405304J	COIL TUN 1 210Z181S [GX-67]
FL241B	EO-405356J	COIL TUN 1 105Z391S 105KHZ [DX-57]
FL271	EH-370972	FILTER LC LP 370972
FR800	*ER-401039J	R FUSE V T05 ERD2FCV 1/4W 4R7J
FR801	*ER-401039J	R FUSE V T05 ERD2FCV 1/4W 4R7J
FR802	*ER-320528	R FUSE H ERD2FC 1/4W 22R0G
IC101	EI-360043	IC M5220P
IC121	EI-394573J	IC CXA1331S
IC141	EI-367572	IC BA15218
IC171	EI-394573J	IC CXA1331S
IC301	EI-373980	IC BA15218N
IC311	EI-373980	IC BA15218N
IC401	EI-373383	IC UPC1297CA
IC501	EI-394574J	IC LA2000
IC502	EI-384868J	IC BU4030B
IC503	EI-310036	IC TC4066BP
IC504	EI-353421	IC BA6229
IC505	EI-353421	IC BA6229
IC801	*EI-377101	IC UPC7805HF
J302	EJ-336905	PIN J AJC-035-ACB P 4P
L141	EO-405355J	COIL FIX 3 E1222T472J 472J222J
L241	EO-405355J	COIL FIX 3 E1222T472J 472J222J
L331	EO-361292	COIL FIX 1 RC875 682J [GX-67]
SW101A	ES-405295J	SW PUSH SPUY42 4THROW N [GX-67]
SW101B	ES-405302J	SW PUSH SPUY32 3THROW N [DX-57]
T321A	EO-400766J	COIL OSC 1 T2128 (HX)-7 200KHZ [GX-67]
T321B	EO-405296J	COIL OSC 1 T2130 (HX) 105KHZ [DX-57]
T322	EO-389245J	COIL OSC 1 T2118 100.0KHZ
T421A	EO-400766J	COIL OSC 1 T2128 (HX)-7 200KHZ [GX-67]
T421B	EO-405296J	COIL OSC 1 T2130 (HX) 105KHZ [DX-57]
TR101	ET-400218J	TR 2SC1740S R,S
TR102	ET-378524J	TR 2SC3383 S,T,U
TR103	ET-352726	TR 2SA1392 T,U
TR140	ET-400218J	TR 2SC1740S R,S
TR141	ET-400218J	TR 2SC1740S R,S [GX-67]
TR142	ET-400218J	TR 2SC1740S R,S
TR143	ET-400218J	TR 2SC1740S R,S
TR144	ET-400218J	TR 2SC1740S R,S
TR145	ET-400218J	TR 2SC1740S R,S
TR146	ET-389803J	TR 2SA933S R,S
TR201	ET-400218J	TR 2SC1740S R,S
TR240	ET-400218J	TR 2SC1740S R,S
TR241	ET-400218J	TR 2SC1740S R,S [GX-67]
TR242	ET-400218J	TR 2SC1740S R,S
TR243	ET-400218J	TR 2SC1740S R,S
TR244	ET-400218J	TR 2SC1740S R,S
TR245	ET-400218J	TR 2SC1740S R,S
TR301	ET-378524J	TR 2SC3383 S,T,U
TR311	ET-354414	TR DTC144ES [GX-67]
TR321	ET-400218J	TR 2SC1740S R,S
TR322	ET-400218J	TR 2SC1740S R,S
TR323	ET-373391	TR DTC143ZS
TR324	ET-370310	TR DTC144TS
TR325	ET-370310	TR DTC144TS
TR326	ET-354371	TR DTC124ES
TR327	ET-396072J	TR 2SD2159 V,W
TR328	ET-400741J	TR 2SC3708 T T05

Ref.No.	Part No.	Description
TR329	ET-400741J	TR 2SC3708 T T05
TR330	ET-354364	TR DTC143TS
TR401	ET-378524J	TR 2SC3383 S,T,U
TR411	ET-354414	TR DTC144ES [GX-67]
TR501	ET-360399	TR DTC114TS
TR502	ET-373382	TR DTA143ZS
TR503	ET-373382	TR DTA143ZS
TR504	ET-354365	TR DTC114YS
TR505	ET-396072J	TR 2SD2159 V,W
TR506	ET-396072J	TR 2SD2159 V,W
TR507	ET-354365	TR DTC114YS
TR508	ET-354385	TR DTC114YS
TR510	ET-354365	TR DTC114YS
TR801	ET-365394	TR 2SC3242A E,F,G F05
TR802	ET-347738	TR 2SA1282A E,F F05
TR804	*ET-378524J	TR 2SC3383 S,T,U
TR805	ET-400218J	TR 2SC1740S R,S
TR806	ET-364093	TR 2SA1283 E,F
VR101	EV-394962J	R S-FIX H T05EVNDXAA03 0.1W102
VR102	EV-389478J	R S-FIX H T05EVNDXAA03 0.1W153
VR171	EV-397174J	R S-FIX H T05EVNDXAA03 0.1W683
VR181	EV-389482J	R S-FIX H T05EVNDXAA03 0.1W682 [GX-67]
VR201	EV-394962J	R S-FIX H T05EVNDXAA03 0.1W102
VR202	EV-389478J	R S-FIX H T05EVNDXAA03 0.1W153
VR271	EV-397174J	R S-FIX H T05EVNDXAA03 0.1W683
VR281	EV-389482J	R S-FIX H T05EVNDXAA03 0.1W682 [GX-67]
VR311	EV-389479J	R S-FIX H T05EVNDXAA03 0.1W223
VR321	EV-389482J	R S-FIX H T05EVNDXAA03 0.1W682
VR322A	EV-389481J	R S-FIX H T05EVNDXAA03 0.1W473 [GX-67]
VR322B	EV-397174J	R S-FIX H T05EVNDXAA03 0.1W683 [DX-57]
VR323	EV-389476J	R S-FIX H T05EVNDXAA03 0.1W103
VR423	EV-389476J	R S-FIX H T05EVNDXAA03 0.1W103
VR901	EV-405297J	VR RK14K12B0 SPL C1253X2 [GX-67]
VR902	EV-405298J	VR ROTARY RK11K1120 B102
VR903	EV-405299J	VR ROTARY RK16312A0 A104X2
VR904	EV-405300J	VR ROTARY RK11K1120 SP W254
VR905	EV-405301J	VR ROTARY RK14K12B0 A503X2
F1A	*EF-309387	FUSE TSC A 250V 1.00A [U]
F1B	*EF-358641	FUSE BET T 250V 800MA [E,B,S]
F2A	*EF-309387	FUSE TSC A 250V 1.00A [U]
F2B	*EF-358641	FUSE BET T 250V 800MA [E,B,S]

5. HEAD PHONE P.C BOARD

Ref.No.	Part No.	Description
J301	EJ-369995	PHONE J 3P HLJ0540-410 GP 6.3

6. POWER SW P.C BOARD

Ref.No.	Part No.	Description
C815	*EC-338411	C CE V DE7 FZ 103P 400AC
SW801	*ES-3711104	SW PUSH SDDL1 01-1 [POWER SW]

7. SYSCON P.C BOARD

Ref.No.	Part No.	Description
D701	ED-307572	D SILICON H 1SS131
D702	ED-307572	D SILICON H 1SS131
D703	ED-307572	D SILICON H 1SS131
D704	ED-307572	D SILICON H 1SS131
D705	ED-307572	D SILICON H 1SS131
D706	ED-307572	D SILICON H 1SS131
D707	ED-307572	D SILICON H 1SS131
D708	ED-307572	D SILICON H 1SS131
D709	ED-307572	D SILICON H 1SS131
D710	ED-307572	D SILICON H 1SS131
D711	ED-307572	D SILICON H 1SS131 [GX-67]
D712	ED-307572	D SILICON H 1SS131
D713	ED-307572	D SILICON H 1SS131
D714	ED-307572	D SILICON H 1SS131 [GX-67]
D715	ED-307572	D SILICON H 1SS131
D716	ED-307572	D SILICON H 1SS131
D717	ED-307572	D SILICON H 1SS131
D718	ED-307572	D SILICON H 1SS131 [GX-67]
D719	ED-307572	D SILICON H 1SS131
D720	ED-307572	D SILICON H 1SS131
D721	ED-307572	D SILICON H 1SS131
D722	ED-307572	D SILICON H 1SS131
D723	ED-307572	D SILICON H 1SS131 [GX-67]
D724	ED-307572	D SILICON H 1SS131 [GX-67]
D725	ED-307572	D SILICON H 1SS131
D726	ED-307572	D SILICON H 1SS131
D727	ED-307572	D SILICON H 1SS131 [GX-67]
D728	ED-307572	D SILICON H 1SS131
D729	ED-307572	D SILICON H 1SS131
D730	ED-307572	D SILICON H 1SS131
D731	ED-307572	D SILICON H 1SS131
D732	ED-307572	D SILICON H 1SS131
IC701	EI-405498J	IC M50941-6275P 91DECK2
IN701	EM-405274J	IND FL CM1068C DOUBLE
RM701	ET-403246J	DETECTOR HC-377
TR701	ET-400218J	TR 2SC1740S R,S
TR702	ET-400218J	TR 2SC1740S R,S
TR703	ET-405594J	TR DTC143ZL T05
TR704	ET-396487J	TR DTA124XL T05
TR705	ET-396488J	TR DTC144EL T05
TR706	ET-396487J	TR DTA124XL T05
TR707	ET-396488J	TR DTC144EL T05
TR708	ET-396487J	TR DTA124XL T05
TR709	ET-396488J	TR DTC144EL T05
TR710	ET-396487J	TR DTA124XL T05
TR711	ET-371075	TR DTA124XS
TR712	ET-354414	TR DTC144ES
TR713	ET-371075	TR DTA124XS
TR714	ET-354414	TR DTC144ES
TR715	ET-371075	TR DTA124XS
TR716	ET-354414	TR DTC144ES
TR717	ET-354414	TR DTC144ES [GX-67]
TR718	ET-354415	TR DTA144ES
TR719	ET-354415	TR DTA144ES [GX-67]

Ref.No.	Part No.	Description
TR720	ET-354415	TR DTA144ES
TR721	ET-354415	TR DTA144ES [GX-67]
TR722	ET-354415	TR DTA144ES
TR723	ET-354415	TR DTA144ES
TR724	ET-354415	TR DTA144ES [GX-67]
TR725	ET-354415	TR DTA144ES
TS701	ES-396610J	SW TACT SOR-122HS T05 [REW]
TS702	ES-396610J	SW TACT SOR-122HS T05 [PLAY]
TS703	ES-396610J	SW TACT SOR-122HS T05 [FF]
TS704	ES-396610J	SW TACT SOR-122HS T05 [REC]
TS705	ES-396610J	SW TACT SOR-122HS T05 [STOP]
TS706	ES-396610J	SW TACT SOR-122HS T05 [AUTO MUTE]
TS707	ES-396610J	SW TACT SOR-122HS T05 [COUNTER RESET]
TS708	ES-396610J	SW TACT SOR-122HS T05 [COUNTER MEMORY]
TS709	ES-396610J	SW TACT SOR-122HS T05 [COUNTER MODE][GX-67]
TS710	ES-396610J	SW TACT SOR-122HS T05 [TAPE LENGTH][GX-67]
TS711	ES-396610J	SW TACT SOR-122HS T05 [TAPE MONITOR]
X701	EI-405327J	OSC CE CST6.00MGW 6.000MHZ

8. TIMER SW P.C BOARD

Ref.No.	Part No.	Description
SW701	ES-370965	SW SLIDE SSSU02 1-01-03N

9. EJECT SW P.C BOARD (GX-67)

Ref.No.	Part No.	Description
TS712	ES-396610J	SW TACT SOR-122HS T05

10. MAIN ASSEMBLY BLOCK

Ref.No.	Part No.	Description
1	MZ-391475J	PLATE EJECT [DX-57]
2	MZ-391606J	DAMPER K-106
3A	BB-T2130A050A	MECHA BLK GX-67 [GX-67]
3B	BB-T2130A050B	MECHA BLK DX-57 [DX-57]
4	SA-379375	FOOT (N)
5	ZS-305827	ST BID30X06STL BNI
6	ZS-336714	ST BID30X12STL CMT
8A	*BT-391561J	TRANS POW T2118 U [U]
8B	*BT-405379J	TRANS POW T2130 E [E]
8C	*BT-391564J	TRANS POW T2118 BS [B.S]
9	ZW-273914	SW40
10	ZS-322580	ST BID40X08STL BNI
11A	*EW-363656	AC CORD200 0129AVFF B200 A U/T [U]
11B	*EW-363669	AC CORD200 0364 LCFL B200 A EV [E]
11C	*EW-363681	AC CORD200 LCFL B200 A B [B]
11D	*EW-363695	AC CORD220 0436 LCFL B200 A S [S]
12A	SP-405910J	PANEL REAR GX-67 (U)
12B	SP-405912J	PANEL REAR DX-57 (U)
12B	SP-405915J	PANEL REAR GX-67 (E)
12C	SP-405916J	PANEL REAR DX-57 (E)
12D	SP-405917J	PANEL REAR GX-67 (B.S)
12E	SP-405918J	PANEL REAR DX-57 (B.S)
13	ZS-358953	ST BID30X08STL BNI
14	ZS-331532	PT BID30X08STL BNI
15	ED-344244	D LED SLF-601C AMBER
16	BZ-391578J	LID STABILIZER PART [GX-67]
17	SZ-391531J	SHEET DAMP [GX-67]
18	ZG-391481J	SP TORSION STABILIZER (L) [GX-67]
19	ZG-336615	SP PLATE CASSETTE HOLDER (B)
20	TC-405054J1	CASSETTE CASE
21	ES-393376J	SW LEAF SPPB22 01-1 [GX-67]
22	ZS-608106	PAN20X06STL CMT [GX-67]
23	ZG-405059J	SP TORSION (EJECT)
24-B	SK-373236B	KNOB POWER-B
24-G	SK-373236A	KNOB POWER-G
25-B	SK-405070J	KNOB TIMER-B
25-G	SK-405071J	KNOB TIMER-G
26-B	SK-405085J	BUTTON PUSH (2)-B
26-G	SK-405086J	BUTTON PUSH (2)-G
27-B	SK-405087J	KNOB VR (3)-B
27-G	SK-405088J	KNOB VR (3)-G
28-B	SK-405089J	KNOB VR (4)-B
28-G	SK-405090J	KNOB VR (4)-G
30A-B	SP-405099J	PANEL FRONT GX-67-B
30B-B	SP-405101J	PANEL FRONT DX-57-B
30C-G	SP-405100J	PANEL FRONT GX-67-G
30D-G	SP-405102J	PANEL FRONT DX-57-G
32	SE-405062J	WINDOW FLD
33	SZ-361424	PLATE REMOCON
34-B	SK-405092J	BUTTON COUNTER (2)-B
34-G	SK-405093J	BUTTON COUNTER (2)-G
35-B	SK-405094J	BUTTON MONITOR (2)-B
35-G	SK-405095J	BUTTON MONITOR (2)-G
36-B	SK-405073J	BUTTON OP GX-67-B
36-G	SK-405074J	BUTTON OP GX-67-G
37A-B	SK-405081J	BUTTON EJECT (2)-B [GX-67]
37A-G	SK-405082J	BUTTON EJECT (2)-G [GX-67]
37B-B	SK-405083J	BUTTON EJECT (3)-B [DX-57]
37B-G	SK-405084J	BUTTON EJECT (3)-G [DX-57]
38A	ZG-405048J	SP PLATE EJECT [GX-67]

Ref.No.	Part No.	Description
38B	ZG-405061J	SP PUSH (EJECT) [DX-57]
39-B	SP-405097J1	PANEL ESCUTCHEON GX-Z6300
39-G	SP-405098J1	PANEL ESCUTCHEON GX-67-G
40	ZS-390457J	BT PAN20X04STL BZN
42-B	SM-365756C	NAME PLATE AKAJ (2)
42-G	SM-365756A	NAME PLATE AKAJ-G
43	SZ-378311-A	CUSHION
50A-B	BD-T2130A090C	LID PANEL BLK GX-67-B
50A-G	BD-T2130A090E	LID PANEL BLK GX-67-G
50B-B	BD-T2130A090D	LID PANEL BLK DX-57-B
50B-G	BD-T2130A090F	LID PANEL BLK DX-57-G
51-B	SP-391493J	COVER UPPER B
51-G	SP-391492J	COVER UPPER G
52-B	ZS-322580	ST BID40X08STL BNI
52-G	ZS-322570	ST BID40X08STL NI3
60	ZS-342733	ST PAN26X04STL CMT [GX-67]
61	MZ-405106J	HOLDER (L) PART [GX-67]
62	ES-405288J	SW LEAF MSW-18120A [GX-67]
63	ZS-487091	PAN23X08STL CMT [GX-67]
64	BM-405969J	MOTOR RF-370 PART [GX-67]
67	ZS-432674	PAN30X03STL CMT [GX-67]
68	ML-405041J	ARM LOCK (1) PART [GX-67]
71	ZW-410051	RETAINING RING E250SUP CMT [GX-67]
72	ML-405038J	ARM EJECT (2) PART [GX-67]
75	ZG-405058J	SP TORSION (EJ) ARM [GX-67]
76	MZ-405056J	GEAR CAM EJECT [GX-67]
77	ML-405036J	ARM EJECT (1) PART [GX-67]
78	ES-372912	SW LEAF SPPB21 01-2 [GX-67]
81	ZW-318238	PW30X060X030PBR NI3 [GX-67]
82	ZS-460440	PAN20X04STL CMT [GX-67]

NOTE:

Parts will not be supplied if they are not listed in the parts list, even if they appear on the assembling illustrations with reference No.

11. ACCESSARY

Ref.No.	Part No.	Description
1	EW-383168J	CORD TC-C-05S P-P 2P 2PCS
2A	AX-D4004A010A	REMOCON BLK RC-G67 [GX-67]
2B	AX-D4004A010B	REMOCON BLK RC-G57 [DX-57]

FINAL ASSEMBLY BLOCK

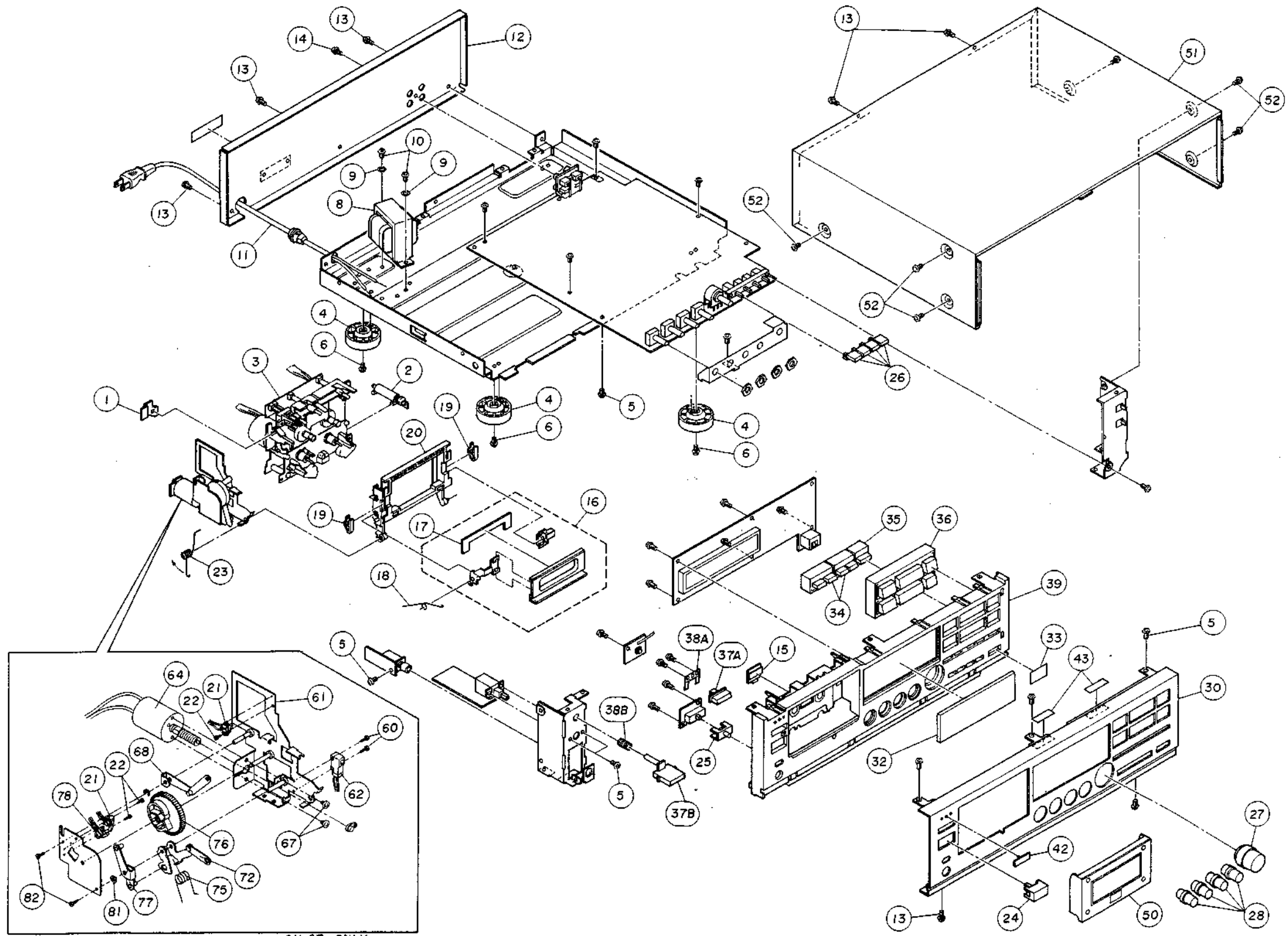

GX-67 ONLY

PARTS LIST

NOTE

AKAI

MODEL **DX-57**

MODEL **GX-67**

SCHEMATIC DIAGRAMS AND PC BOARDS

TABLE OF CONTENTS

1. DX-57 BLOCK DIAGRAM	3
2. GX-67 BLOCK DIAGRAM	4
3. CONNECTION DIAGRAM	6
4. DX-57 PRE AMP SCHEMATIC DIAGRAM	7
5. GX-67 PRE AMP SCHEMATIC DIAGRAM	8
6. PRE AMP AND OTHER PC BOARDS	9
7. SYSCON SCHEMATIC DIAGRAM	10
8. SYSCON PC BOARD	11
9. EJECT SW AND TIMER SW PC BOARDS	12

Use these schematic diagrams and PC boards together with the provided service manual.

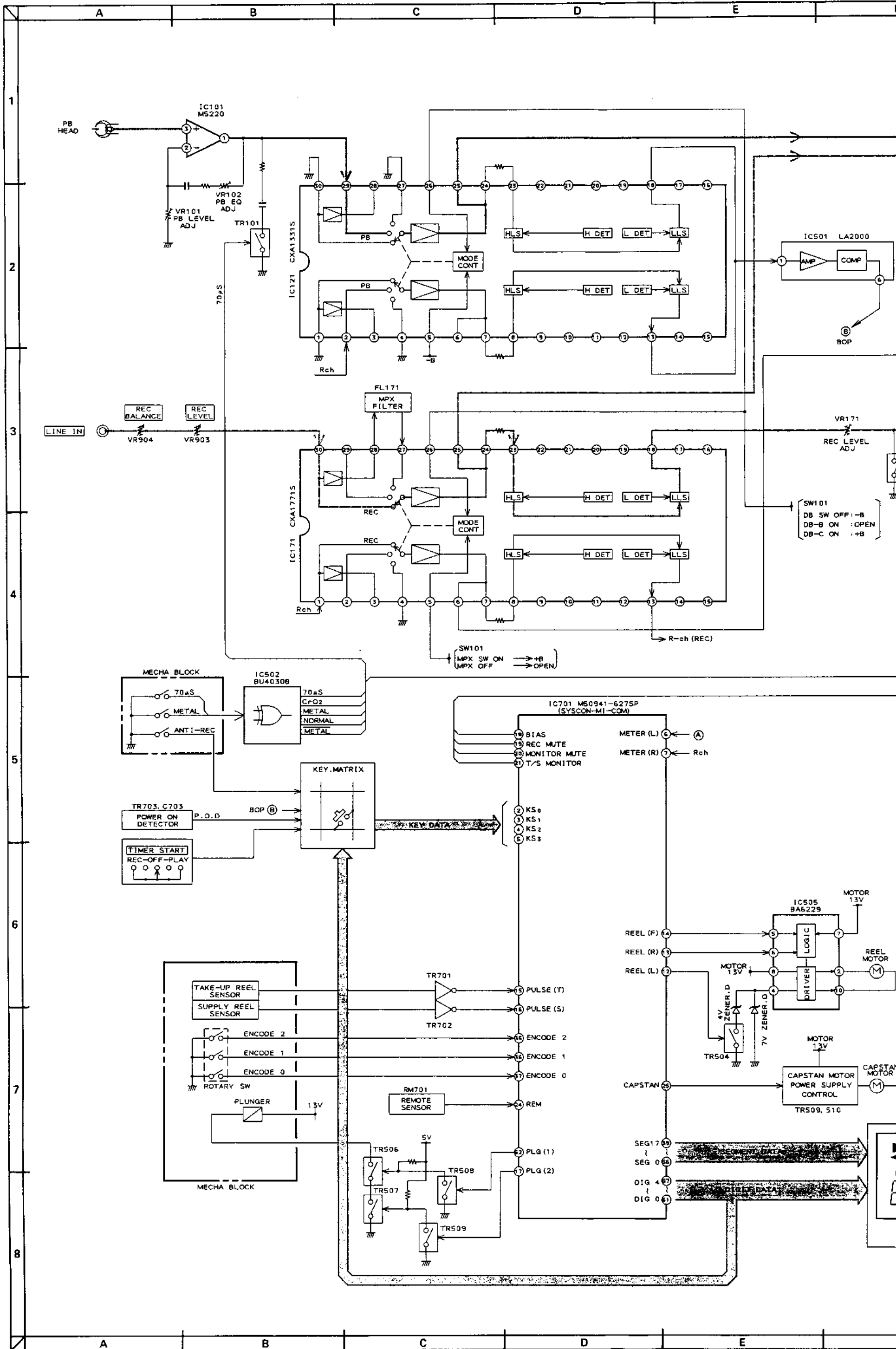

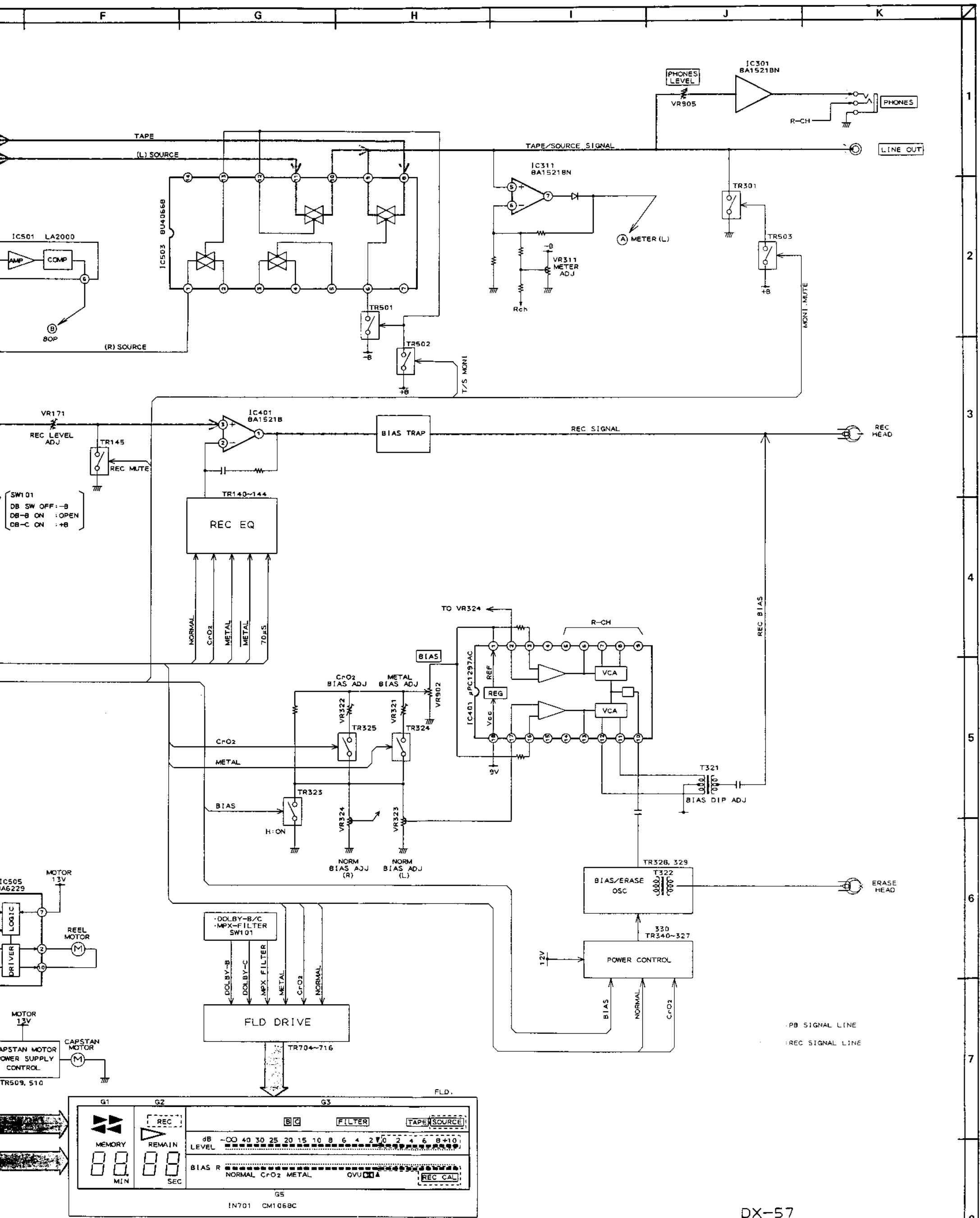

DX-57
BLOCK DIAGRAM
No. 2-1 T213053M
A1

1
2
3
4
5
6
7
8
3

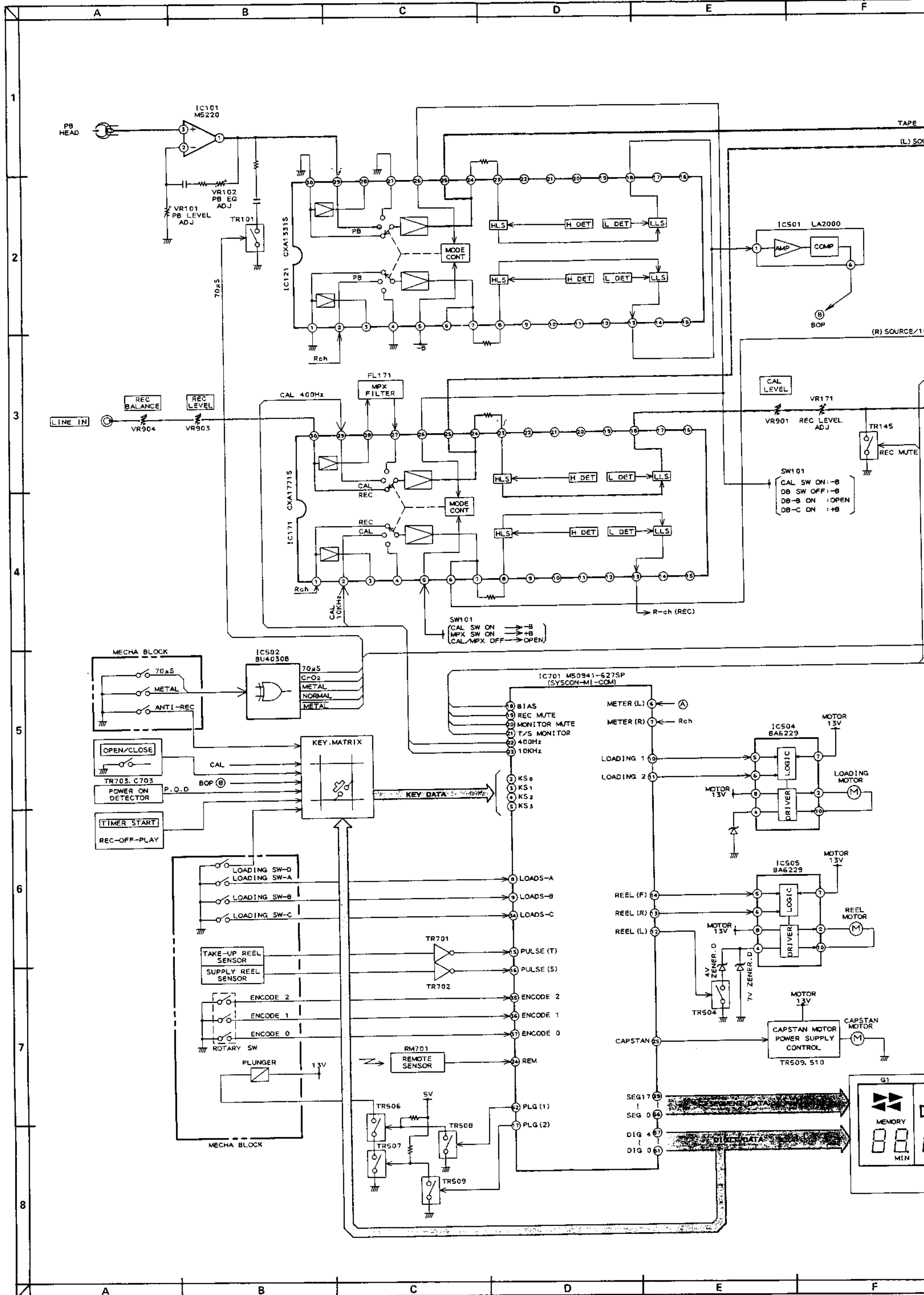

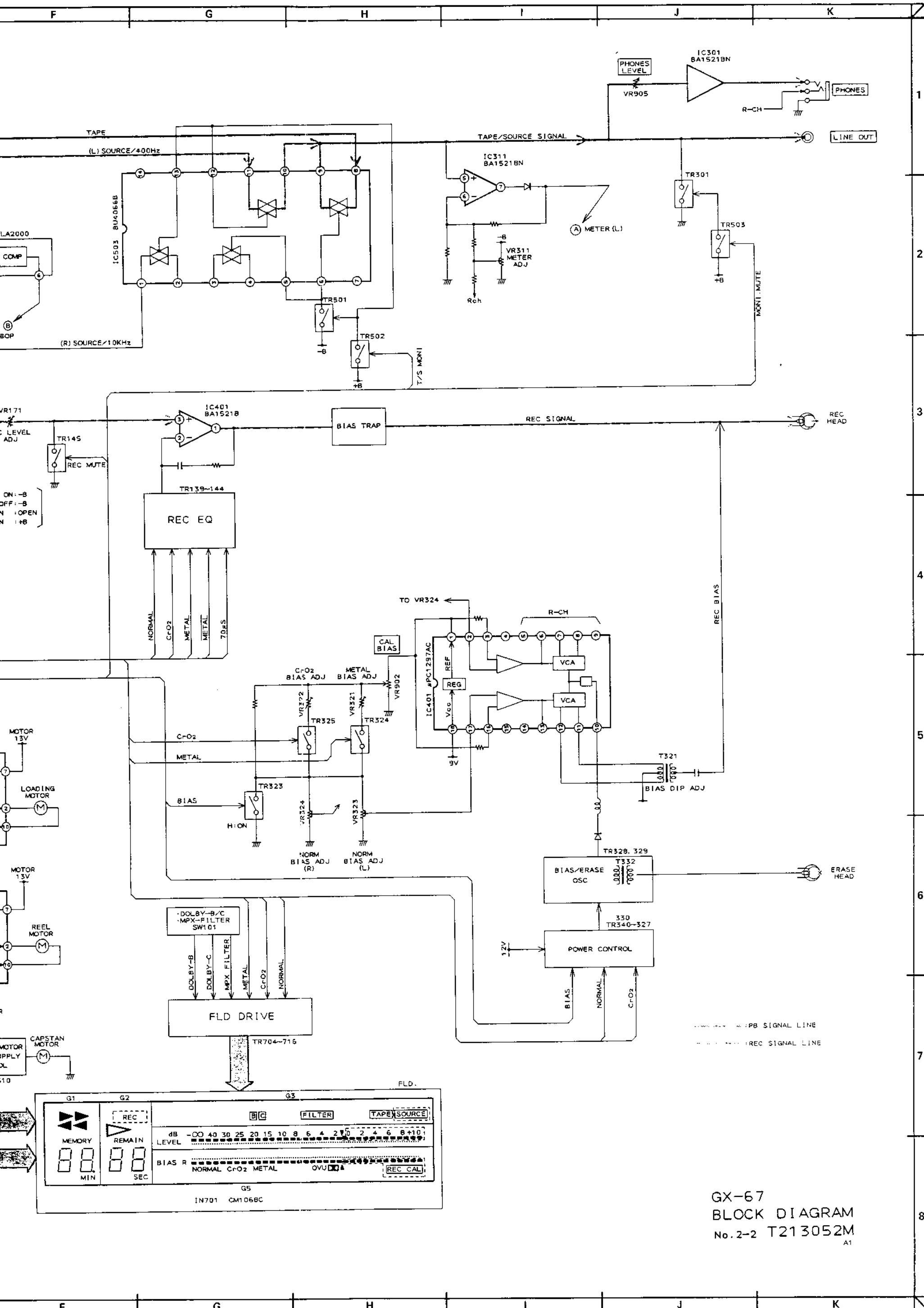

GX-67
 BLOCK DIAGRAM
 No. 2-2 T213052M
 A1

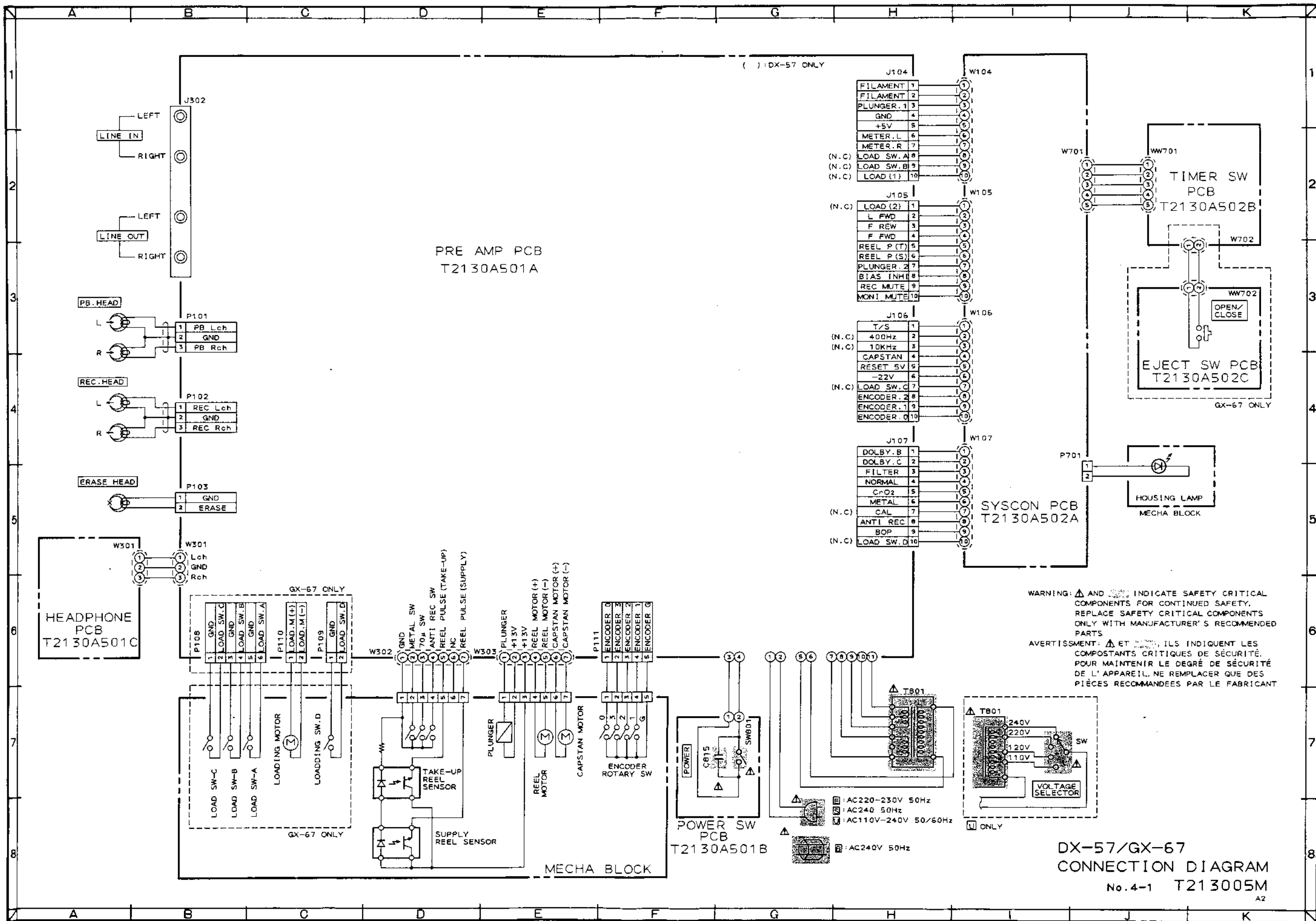

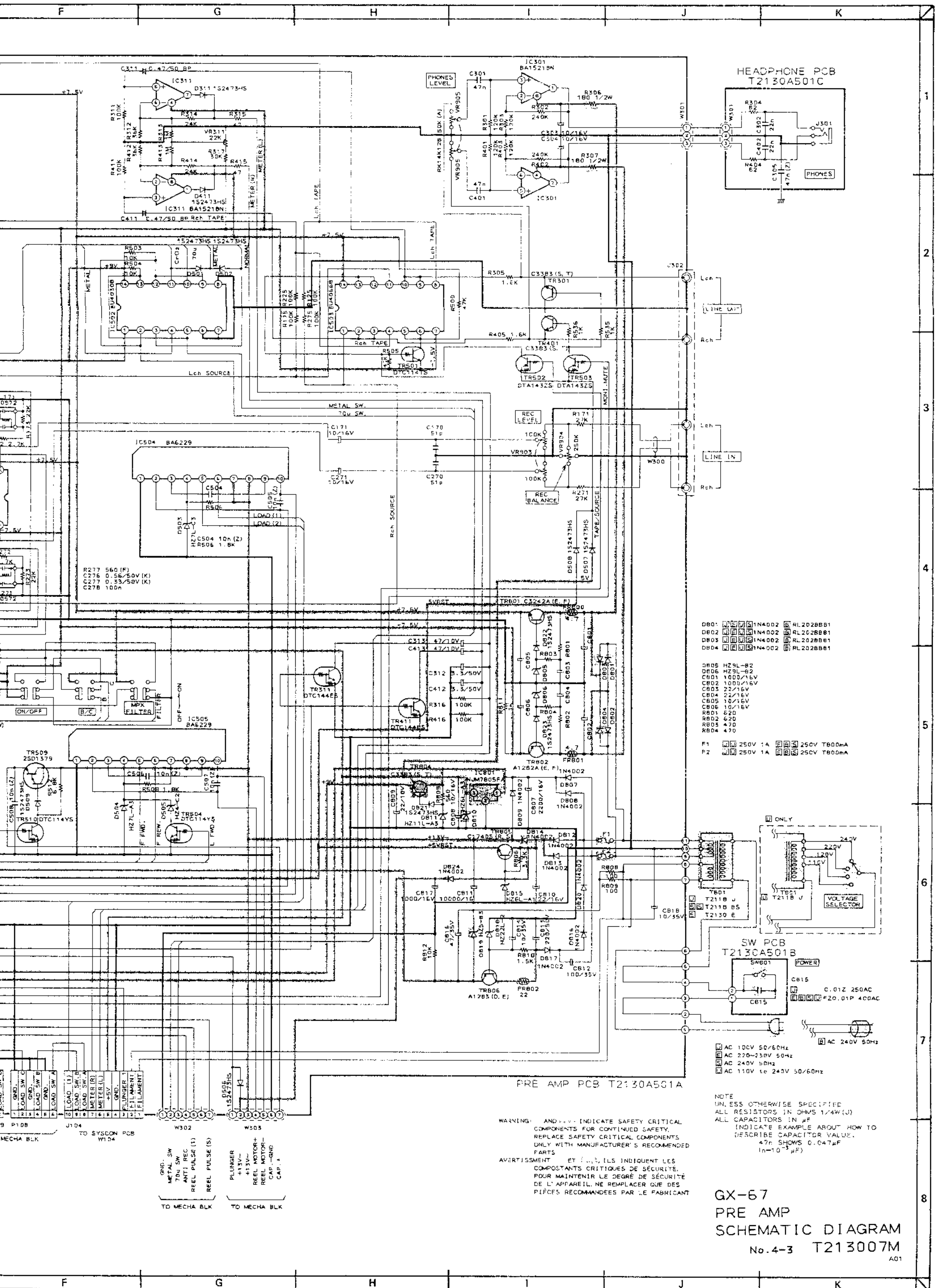

- DB0: [Symbol] 1N4002 [Symbol] RL202BB81
- DB2: [Symbol] 1N4002 [Symbol] RL202BB81
- DB3: [Symbol] 1N4002 [Symbol] RL202BB81
- DB4: [Symbol] 1N4002 [Symbol] RL202BB81

- DB5: HZ9L-B2
- DB6: HZ9L-B2
- CB0: 1000/16V
- CB2: 1000/16V
- CB5: 22/16V
- CB4: 22/16V
- CB05: 10/16V
- CB6: 10/16V
- RB1: 520
- RB2: 620
- RB3: 470
- RB4: 470

- F1: [Symbol] 250V 1A [Symbol] 250V T600mA
- F2: [Symbol] 250V 1A [Symbol] 250V T600mA

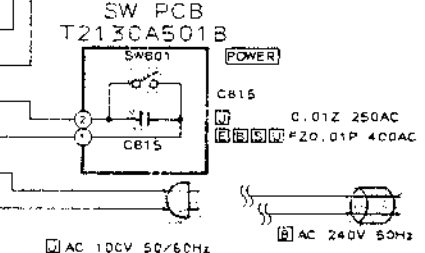
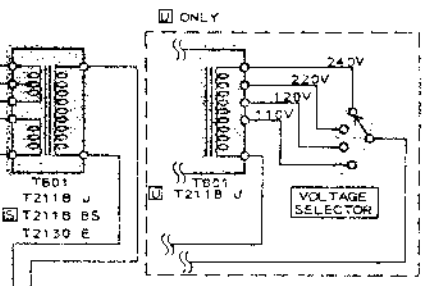

NOTE
 UNLESS OTHERWISE SPECIFIED
 ALL RESISTORS IN OHMS 1/4W (J)
 ALL CAPACITORS IN μ F
 INDICATE EXAMPLE ABOUT HOW TO
 DESCRIBE CAPACITOR VALUE.
 47n SHOWS 0.047 μ F
 1n-10⁻³ μ F

WARNING: AND ... INDICATE SAFETY CRITICAL COMPONENTS FOR CONTINUED SAFETY. REPLACE SAFETY CRITICAL COMPONENTS ONLY WITH MANUFACTURER'S RECOMMENDED PARTS

AVERTISSEMENT: ET ... ILS INDIQUENT LES COMPOSANTS CRITIQUES DE SÉCURITÉ. POUR MAINTENIR LE DEGRÉ DE SÉCURITÉ DE L'APPAREIL, NE REMPLACER QUE DES PIÈCES RECOMMANDÉES PAR LE FABRICANT

GX-67
PRE AMP
SCHEMATIC DIAGRAM
 No. 4-3 T213007M
 A01

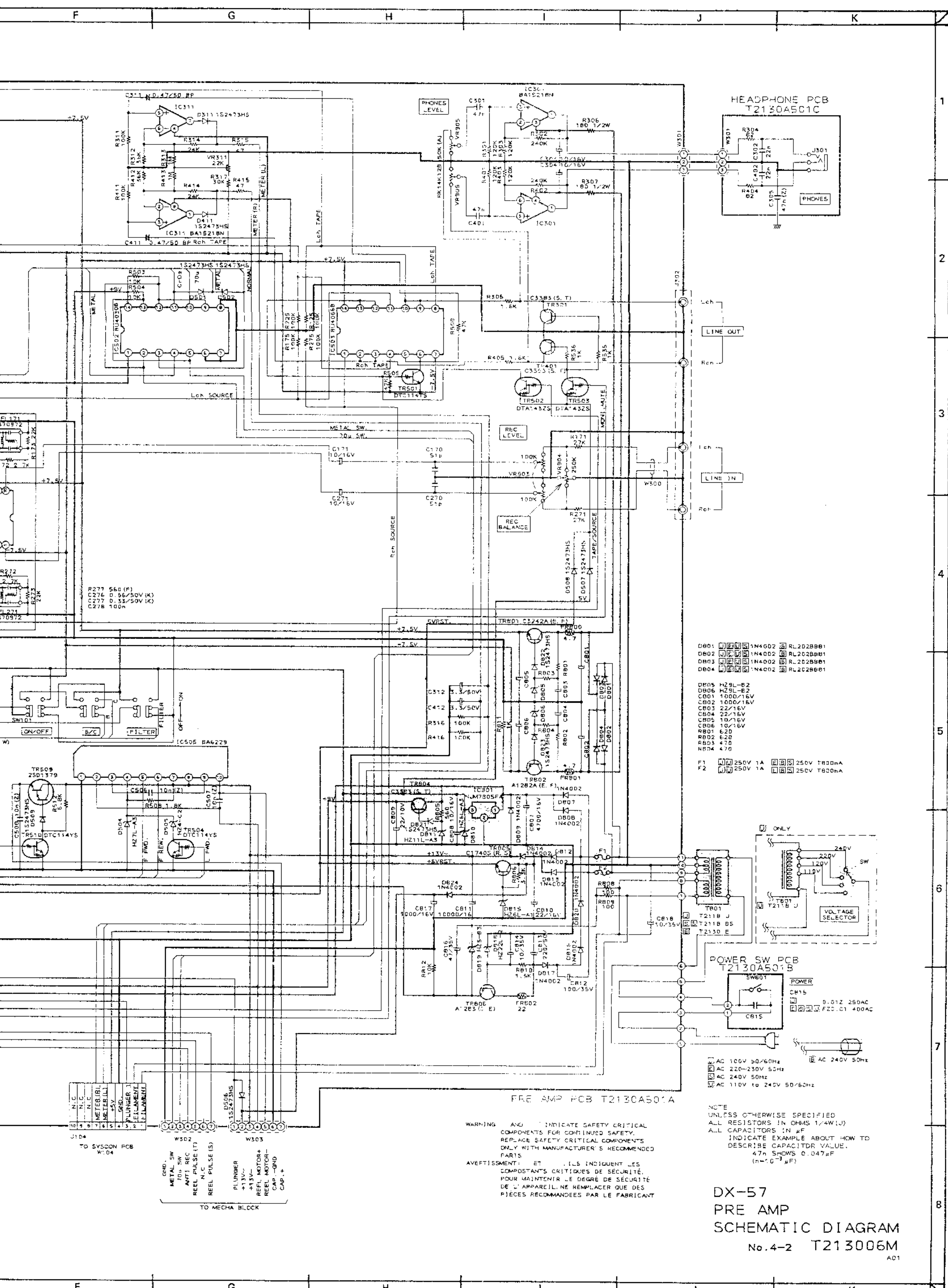

- D801: [Symbol] 1N4002 [Symbol] RL202B801
- D802: [Symbol] 1N4002 [Symbol] RL202B801
- D803: [Symbol] 1N4002 [Symbol] RL202B801
- D804: [Symbol] 1N4002 [Symbol] RL202B801
- D805: [Symbol] 1N4002 [Symbol] RL202B801
- D806: [Symbol] 1N4002 [Symbol] RL202B801
- D807: [Symbol] 1N4002 [Symbol] RL202B801
- D808: [Symbol] 1N4002 [Symbol] RL202B801
- D809: [Symbol] 1N4002 [Symbol] RL202B801
- D810: [Symbol] 1N4002 [Symbol] RL202B801
- D811: [Symbol] 1N4002 [Symbol] RL202B801
- D812: [Symbol] 1N4002 [Symbol] RL202B801
- D813: [Symbol] 1N4002 [Symbol] RL202B801
- D814: [Symbol] 1N4002 [Symbol] RL202B801
- D815: [Symbol] 1N4002 [Symbol] RL202B801
- D816: [Symbol] 1N4002 [Symbol] RL202B801
- D817: [Symbol] 1N4002 [Symbol] RL202B801
- D818: [Symbol] 1N4002 [Symbol] RL202B801
- D819: [Symbol] 1N4002 [Symbol] RL202B801
- D820: [Symbol] 1N4002 [Symbol] RL202B801
- D821: [Symbol] 1N4002 [Symbol] RL202B801
- D822: [Symbol] 1N4002 [Symbol] RL202B801
- D823: [Symbol] 1N4002 [Symbol] RL202B801
- D824: [Symbol] 1N4002 [Symbol] RL202B801
- D825: [Symbol] 1N4002 [Symbol] RL202B801
- D826: [Symbol] 1N4002 [Symbol] RL202B801
- D827: [Symbol] 1N4002 [Symbol] RL202B801
- D828: [Symbol] 1N4002 [Symbol] RL202B801
- D829: [Symbol] 1N4002 [Symbol] RL202B801
- D830: [Symbol] 1N4002 [Symbol] RL202B801
- D831: [Symbol] 1N4002 [Symbol] RL202B801
- D832: [Symbol] 1N4002 [Symbol] RL202B801
- D833: [Symbol] 1N4002 [Symbol] RL202B801
- D834: [Symbol] 1N4002 [Symbol] RL202B801
- D835: [Symbol] 1N4002 [Symbol] RL202B801
- D836: [Symbol] 1N4002 [Symbol] RL202B801
- D837: [Symbol] 1N4002 [Symbol] RL202B801
- D838: [Symbol] 1N4002 [Symbol] RL202B801
- D839: [Symbol] 1N4002 [Symbol] RL202B801
- D840: [Symbol] 1N4002 [Symbol] RL202B801

- F1: [Symbol] 250V 1A [Symbol] 250V 1000mA
- F2: [Symbol] 250V 1A [Symbol] 250V 1000mA

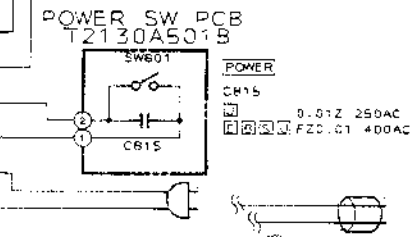
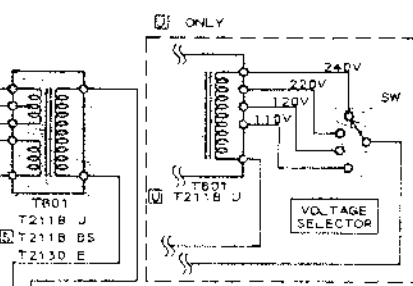

- [Symbol] AC 100V 50/60Hz
- [Symbol] AC 220-230V 50Hz
- [Symbol] AC 240V 50Hz
- [Symbol] AC 110V to 240V 50/60Hz

WARNING AND [Symbol] INDICATE SAFETY CRITICAL COMPONENTS FOR CONTINUED SAFETY. REPLACE SAFETY CRITICAL COMPONENTS ONLY WITH MANUFACTURER'S RECOMMENDED PARTS.

AVERTISSEMENT: ET [Symbol] ILS INDICENT LES COMPOSANTS CRITIQUES DE SECURITE. POUR MAINTENIR LE DEGRE DE SECURITE DE L'APPAREIL, NE REMPLACER QUE DES PIECES RECOMMANDEES PAR LE FABRICANT.

DX-57
PRE AMP
SCHEMATIC DIAGRAM
No. 4-2 T213006M
A01

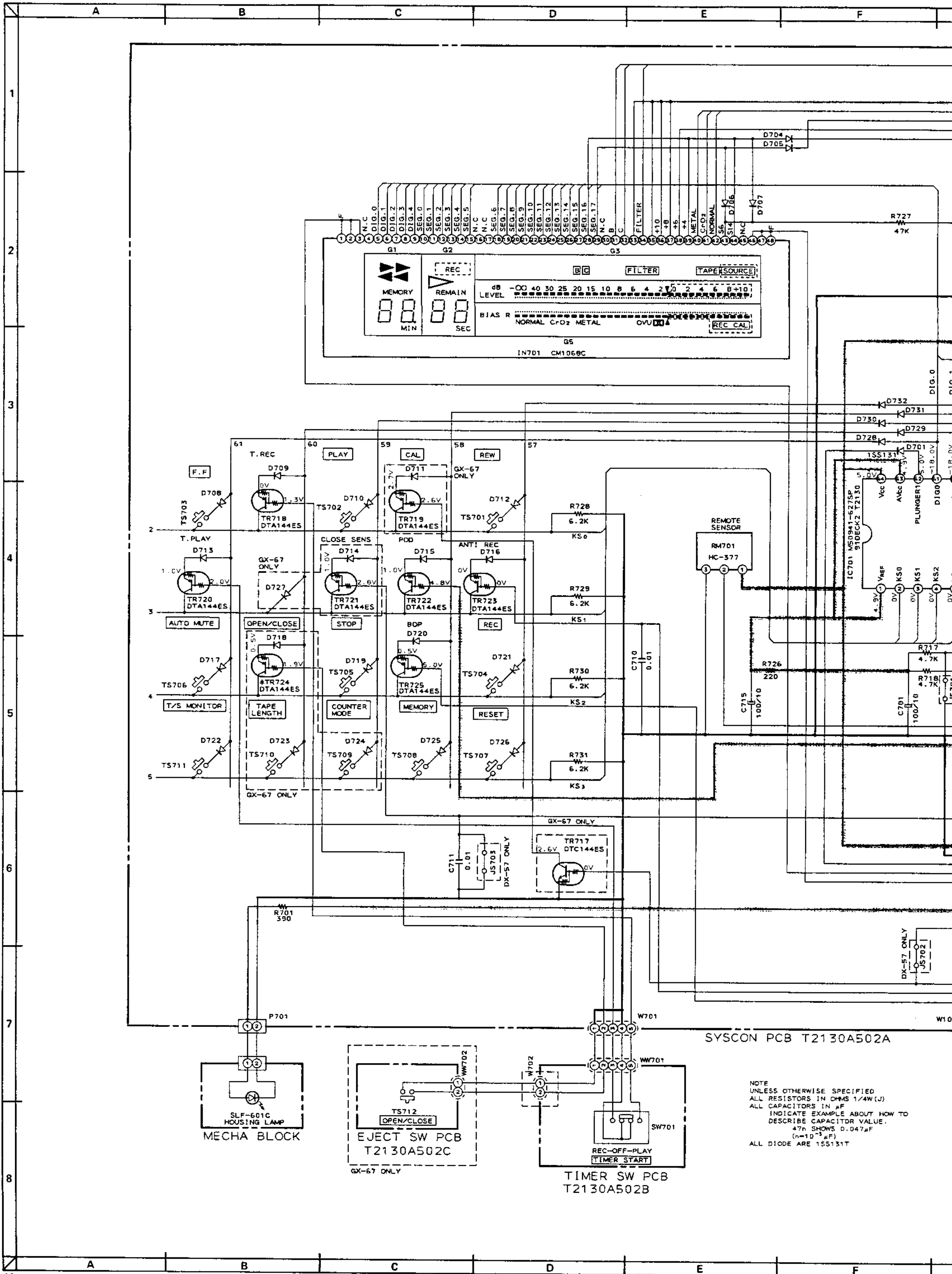

SYSCON PCB T2130A502A

NOTE
 UNLESS OTHERWISE SPECIFIED
 ALL RESISTORS IN OHMS 1/4W(J)
 ALL CAPACITORS IN μ F
 INDICATE EXAMPLE ABOUT HOW TO
 DESCRIBE CAPACITOR VALUE.
 47n SHOWS 0.047 μ F
 (n=10⁻⁹ μ F)
 ALL DIODE ARE 1SS131T

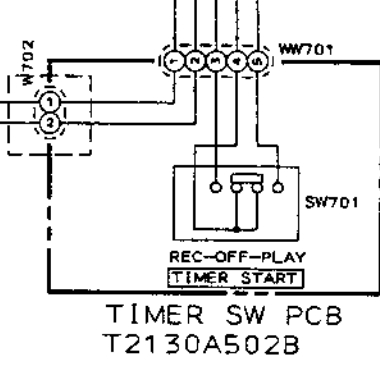
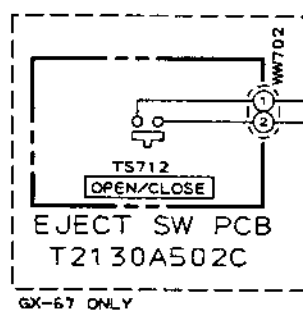
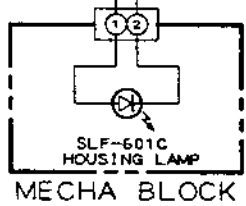

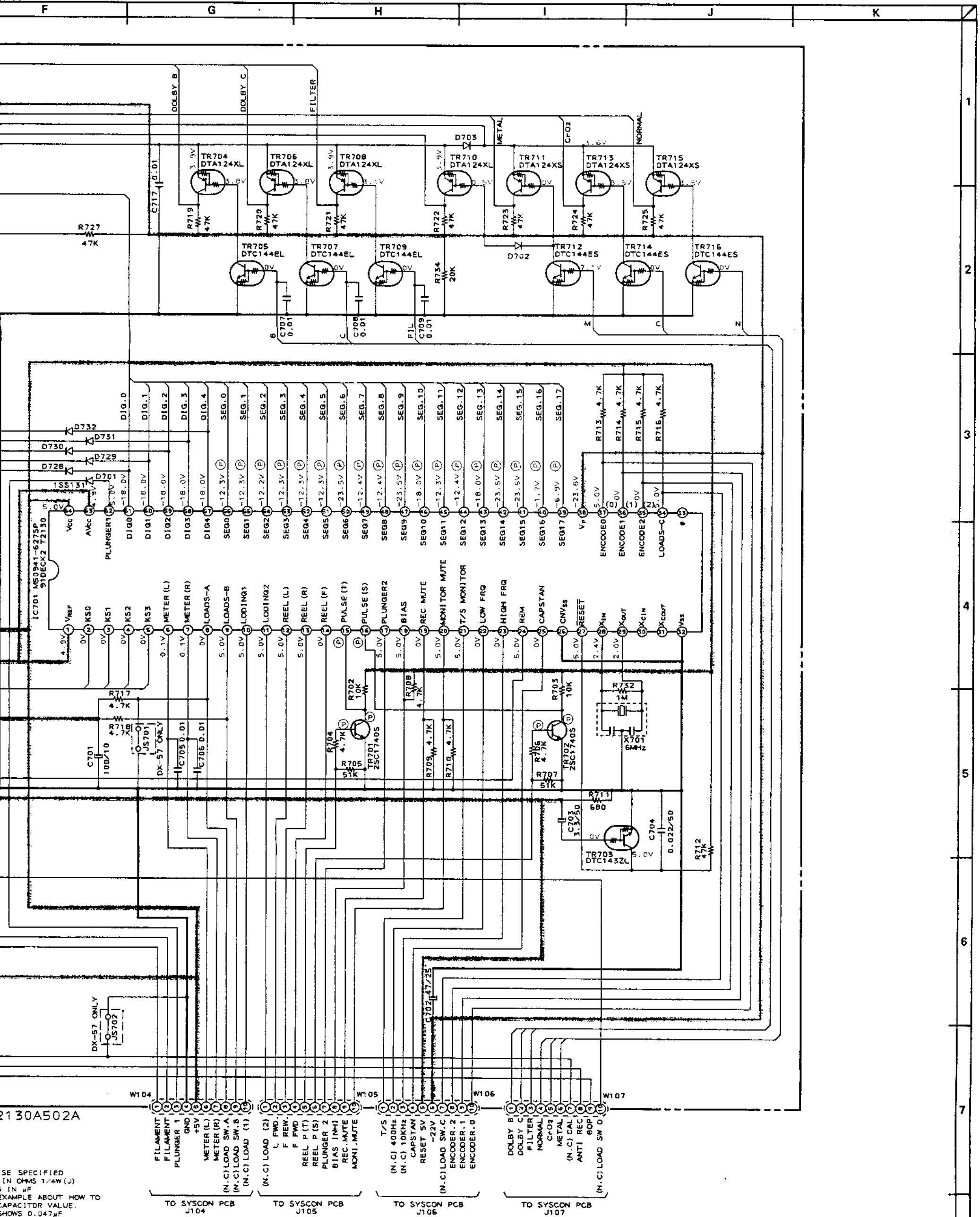

SE SPECIFIED
IN OHMS 1/4W (J)
IN #F
EXAMPLE ABOUT HOW TO
CAPACITR VALUE.
SHOWS 0.047#F
#F)
155131T

() : DX-57 ONLY

INDICATED VOLTAGES WERE
MEASURED DURING PB MODE.
(TAPE USED: METAL TYPE,
DOLBY SW: OFF)

***** B (POWER SUPPLY) LINE

WARNING: Δ AND \square INDICATE SAFETY CRITICAL
COMPONENTS FOR CONTINUED SAFETY.
REPLACE SAFETY CRITICAL COMPONENTS
ONLY WITH MANUFACTURER'S RECOMMENDED
PARTS

AVERTISSEMENT: Δ ET \square ILS INDIQUENT LES
COMPOSANTS CRITIQUES DE SÉCURITÉ.
POUR MAINTENIR LE DEGRÉ DE SÉCURITÉ
DE L'APPAREIL, NE REMPLACER QUE DES
PIÈCES RECOMMANDÉES PAR LE FABRICANT

DX-57/GX-67
SYSCON
SCHEMATIC DIAGRAM
No. 4-4 T213008M
A1

PRINCIPAL PARTS LOCATION

CS

C101	E1,2	TR142	D3,4
C121	C1	TR143	D3,4
C141	C3	TR144	D3,4
C171	E3	TR145	C3
C301	G,H,6	TR146	B5
C311	A,B,3	TR201	E1
C401	C5	TR240	B3,4
C501	B1	TR241	B3,4
C502	F4	TR242	B5,4
C503	A2	TR243	B3,4
C504	F6	TR244	B3,4
CS05	E6	TR245	C3
CS01	B4	TR301	A2
		TR311	B6
		TR321	D5
		TR322	D5
		TR323	D4
		TR324	D4
		TR325	E1
		TR326	E4
		TR327	E4,5
		TR328	D5
		TR329	E5
		TR330	F4,5
		TR401	A3
		TR411	C8
		TR501	A2
		TR502	B4
		TR503	B4
		TR504	E6
		TR505	D6
		TR506	D6
		TR507	D6
		TR508	D6
		TR509	F6
		TR510	E6
		TR801	A4
		TR802	A4
		TR804	A5
		TR805	C6
		TR806	C6

CONNECTORS

P101	F1,2
P102	C4
P103	D5
P108	B5,6
	(67 ONLY)
P109	C5
	(67 ONLY)
P110	F5
	(67 ONLY)
P111	G4
J104	F,G,6
J105	F,G,5
J106	F,G,4,5
J107	F,G,4
J302	A2,3

WIRES

W300	A2,14
W301	F6
W302	F4
W303	F6

TRANSISTORS

TR101	E2
TR102	C1
TR103	D2
TR140	D3,4
TR141	D3,4
	(67 ONLY)

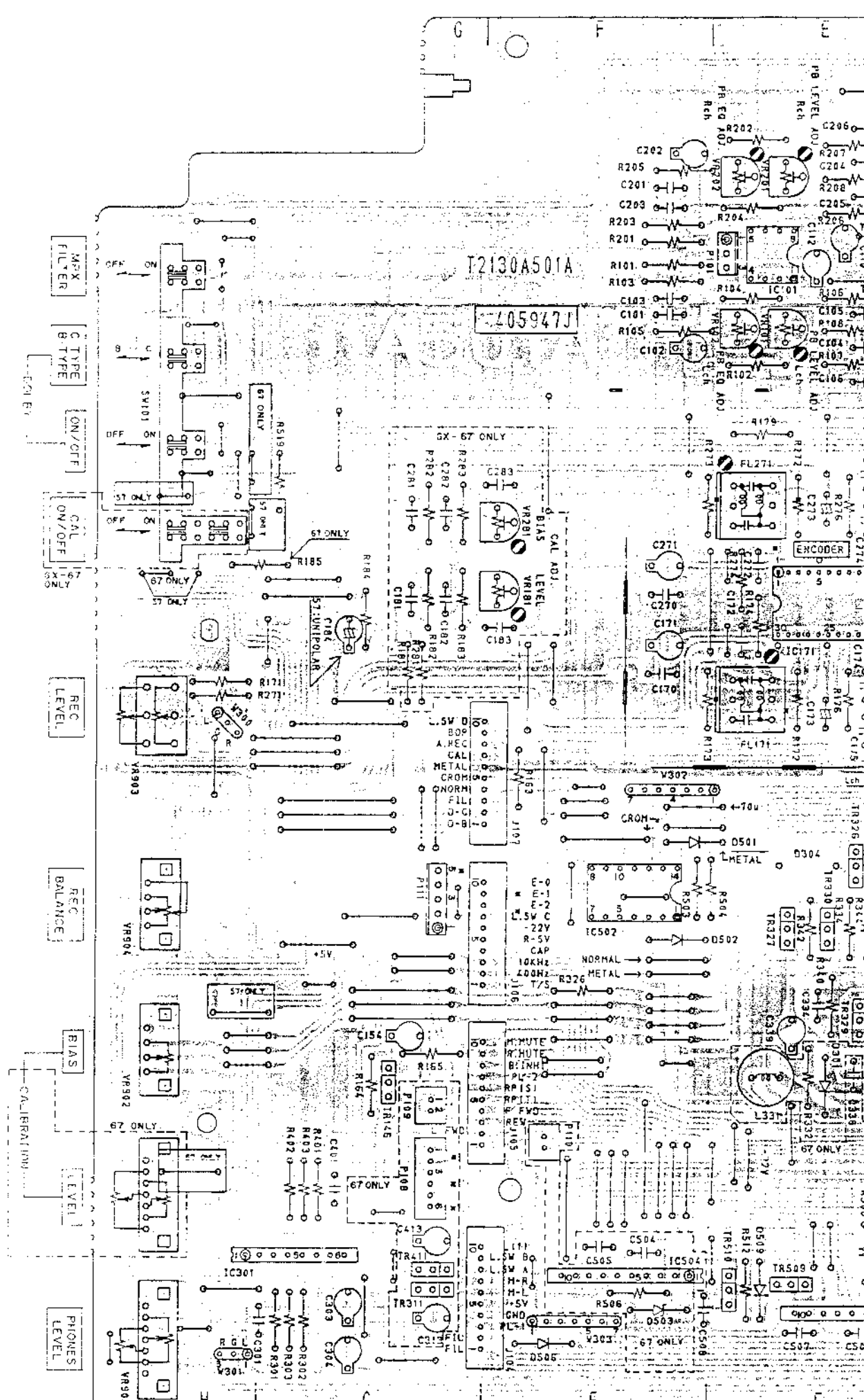

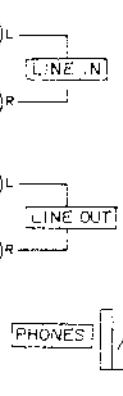
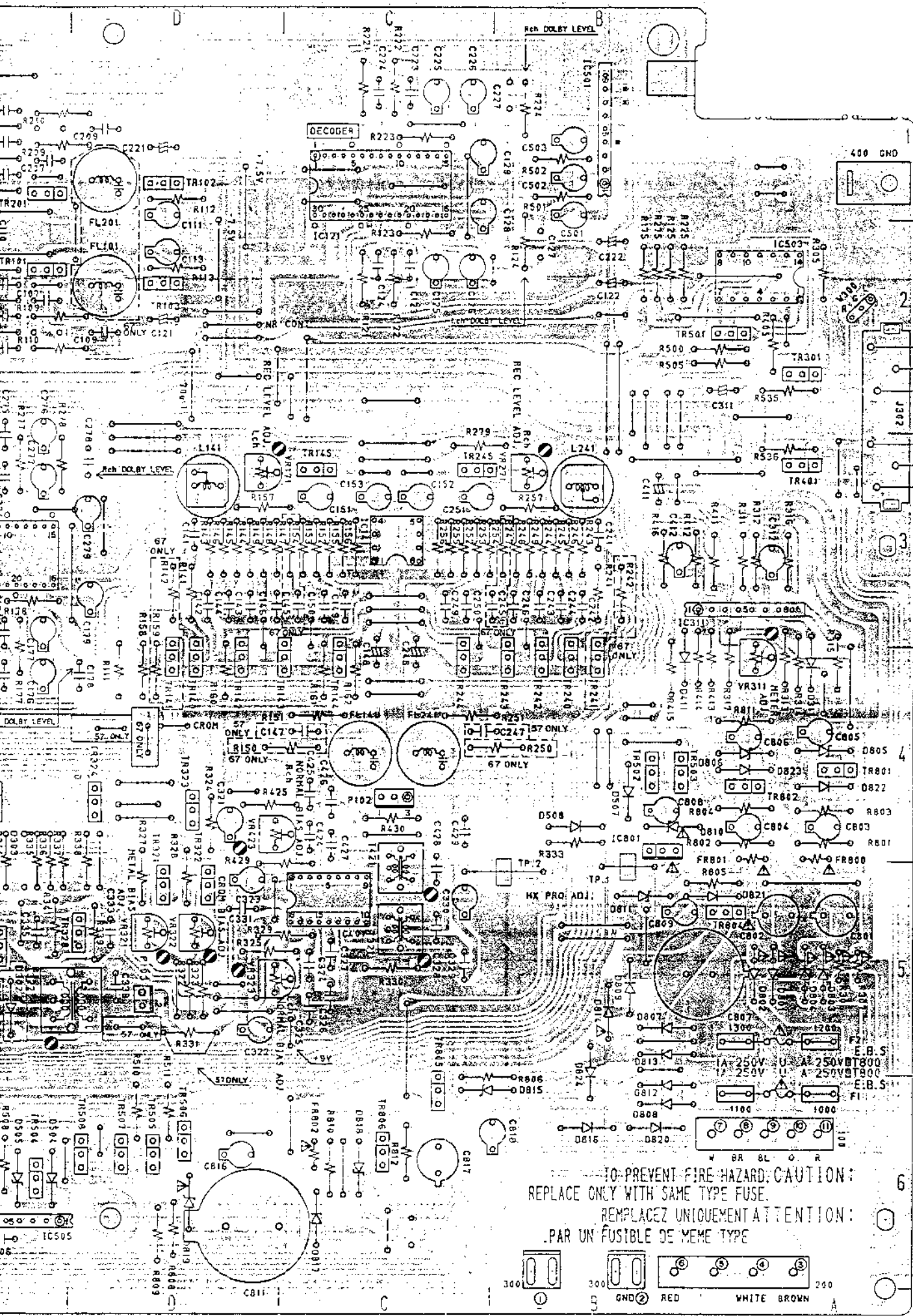

HEADPHONE PCB
T2130A501C

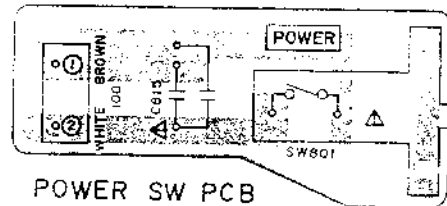

POWER SW PCB
T2130A501B

TO PREVENT FIRE HAZARD, CAUTION:
REPLACE ONLY WITH SAME TYPE FUSE.
REPLACEZ UNIQUEMENT ATTENTION:
PAR UN FUSIBLE DE MEME TYPE

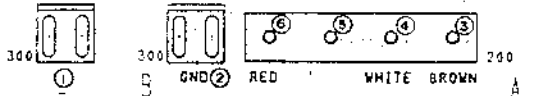

PRE AMP PCB T2130A501A J1

WARNING: INDICATED SAFETY CRITICAL COMPONENTS FOR CONTINUED SAFETY.
REPLACE SAFETY CRITICAL COMPONENTS ONLY WITH MANUFACTURER'S
RECOMMENDED PARTS.
VERBODEN BEVEGEN: AAN GEMERKTE VEILIGHEIDSCRITIEKE COMPONENTEN.
VANG MAAT NEMEN DE DEGREE VAN VEILIGHEID VAN HET APPARAAT.
VERVANG ALLE DE VANG GEMERKTE VEILIGHEIDSCRITIEKE DEELLEN
ALLEEN MET DE DEELLEN AANBEVOLEN DOOR DE FABRICANT.

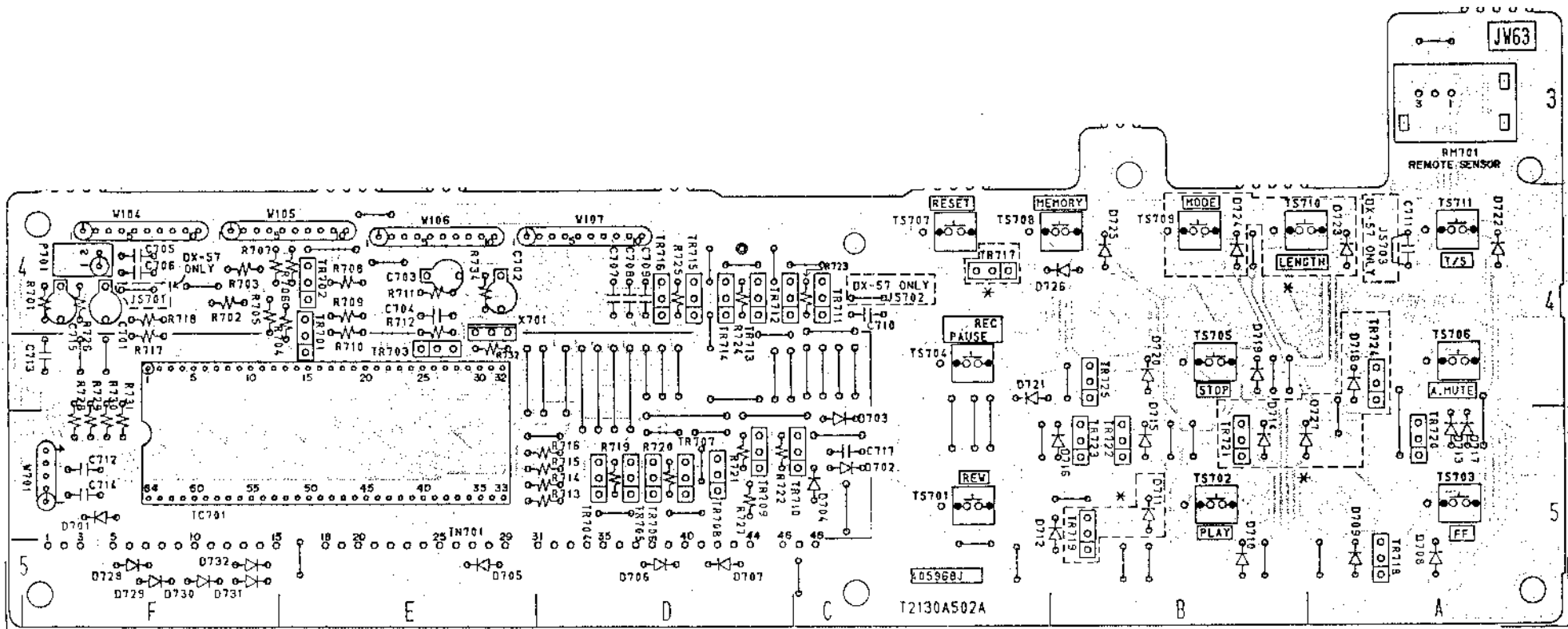

SYSCON PCB T2130A502A

* MARK ARE GX-67 ONLY

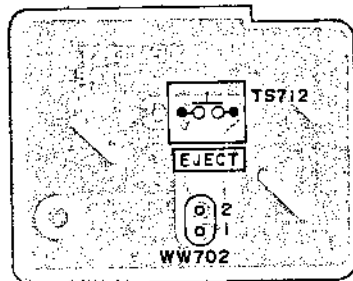

EJECT SW PCB
T2130A502C
(GX-67 ONLY)

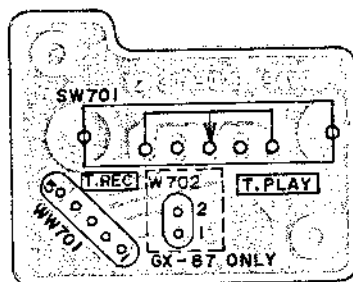

TIMER SW PCB
T2130A502B

ABBREVIATIONS (CASSETTE)

ABBREVIATION	EXPLANATION	ABBREVIATION	EXPLANATION
AC	Alternating Current	MIN	MINute
A/D	Analog/Digital	MML	Maximum Modulation Level
AF	Auto Fader	MOL	Maximum Output Level
AMP	AMPLifier	MPX	Multi PleX
AR	Anti Recording	NC	Not Connected (No Connection)
AT BIAS	Auto Turning BIAS	NFB	Negative Feed Back
ATT	ATTenuator	NORM	NORMal
BAL	BALance	NR	Noise Reduction
BEF	Band Elimination Filter	OSC	OSCillator (OSCillation)
BSS	Blank Search System	P	Pulse
CAP M	CAPstan Motor	PB	Play Back
CH	CHannel	QMSS	Quick Memory Search System
COMP	COMPARator	QR	Quick Reverse
CONT	CONTinuance	R CH	Right CHannel
CRLP	Computer Recording Level Processing	REC	RECord (RECording)
CS	Chip Select	REV	REVerse
D/A	Digital/Analog	ROT	ROTation
DC	Direct Current	REW	REWind
DET	DETECTOR	SEC	SECond
DISCRI	DISCRIminator	SELE	SELEctor
DUB	DUBbing	SENS	SENSitivity
EQ	EQUALizer	SEPP	Single Ended Push Pull
FF (or F.FWD)	Fast Forward	SIG	SIGNAL
FLD	FLuorescent Display	SPECT	SPECTrum
FREQ	FREQUENCY	STD	STANDARD
FWD	ForWARD	SW	SWitch
GND	GrouND	SYSCON	SYStem CONTROL
H	High	TP	Test Point
HPF	High Pass Filter	TRIG	TRIGa
IND	INDicator	VCA	Voltage Control Attenuator
IPLS	Instant Program Location System	VOL	VOLUME
L	Low	VOLT	VOLTage
L CH	Left CHannel	VR	Variable Resistor
LED	Light Emitting Diode	X'TAL	cysTAL
MEMO	MEMORy	X1	Normal speed
MICOM	MicroCOMputer	X2	Dubble speed