

## STEREO TAPE DECK

# MODEL GX-77

THIS MANUAL IS ALSO APPLICABLE TO BOTH SILVER  
AND BLACK PANEL MODELS

SECTION 1	SERVICE MANUAL .....	3
SECTION 2	PARTS LIST .....	45
SECTION 3	SCHEMATIC DIAGRAM .....	65

# SAFETY INSTRUCTIONS

---

## SAFETY CHECK AFTER SERVICING

Confirm the specified insulation resistance between power cord plug prongs and externally exposed parts of the set is greater than 10 Mohms, but for equipment with external antenna terminals (tuner, receiver, etc.) and is intended for **C** or **A**, specified insulation resistance should be more than 2.2 Mohms (ground terminals, microphone jacks, headphone jacks, line-in-out jacks etc.)

## PRECAUTIONS DURING SERVICING

1. Parts identified by the  $\Delta$  symbol parts are critical for safety.  
Replace only with parts number specified.
2. In addition to safety, other parts and assemblies are specified for conformance with such regulations as those applying to spurious radiation. These must also be replaced only with specified replacements.  
Examples: RF converters, tuner units, antenna selector switches, RF cables, noise blocking capacitors, noise blocking filters, etc.
3. Use specified internal wiring. Note especially:
  - 1) Wires covered with PVC tubing
  - 2) Double insulated wires
  - 3) High voltage leads
4. Use specified insulating materials for hazardous live parts. Note especially:
  - 1) Insulation Tape
  - 2) PVC tubing
  - 3) Spacers (Insulating Barriers)
  - 4) Insulation sheets for transistors
5. When replacing AC primary side components (transformers, power cords, noise blocking capacitors, etc.), wrap ends of wires securely about the terminals before soldering.

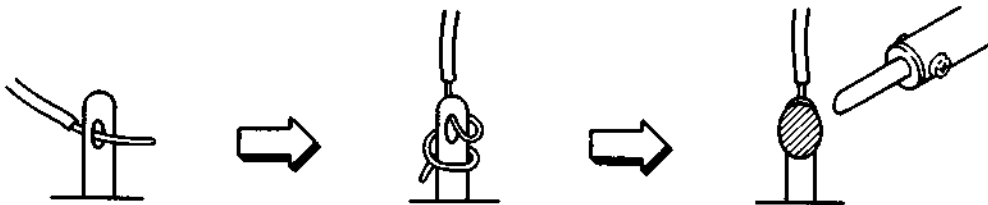

6. Observe that wires do not contact heat producing parts (heatsinks, oxide metal film resistors, fusible resistors, etc.).
7. Check that replaced wires do not contact sharp edged or pointed parts.
8. Also check areas surrounding repaired locations.
9. Use care that foreign objects (screws, solder droplets, etc.) do not remain inside the set.

---

SECTION 1

**SERVICE MANUAL**

TABLE OF CONTENTS

I.	SPECIFICATIONS .....	4
II.	DISMANTLING OF UNIT .....	5
III.	CONTROLS .....	6
IV.	PRINCIPAL PARTS LOCATION .....	8
V.	VOLTAGE AND CYCLE CONVERSION .....	9
	1. VOLTAGE CONVERSION .....	9
	2. CYCLE CONVERSION .....	9
VI.	OPERATING PRINCIPLES .....	10
	1. TIMING CHART OF EACH MODE .....	12
	2. EXPLANATION OF EACH MODE .....	18
	3. EXPLANATION OF EACH CIRCUIT .....	21
VII.	MECHANISM ADJUSTMENT .....	26
	1. BRAKE BAND POSITION ADJUSTMENT AND BRAKE TENSION ADJUSTMENT .....	26
	2. PLAY PLUNGER POSITION ADJUSTMENT .....	27
	3. PINCH ROLLER PRESSURE ADJUSTMENT .....	27
	4. TENSION SERVO ADJUSTMENT .....	28
	5. LOADER PLUNGER POSITION ADJUSTMENT .....	29
	6. TAPE SPEED ADJUSTMENT .....	29
VIII.	HEAD ADJUSTMENT .....	30
IX.	AMPLIFIER ADJUSTMENT .....	32
X.	DC RESISTANCE OF VARIOUS COILS .....	35
XI.	CLASSIFICATION OF VARIOUS P.C BOARDS .....	35
	1. P.C BOARD TITLES AND IDENTIFICATION NUMBERS .....	35
	2. COMPOSITION OF VARIOUS P.C BOARDS .....	36

For basic adjustments, measuring methods, and operating principles, refer to GENERAL TECHNICAL MANUAL.

# I. SPECIFICATIONS

TRACK SYSTEM	4 Track 2 Channel Stereo System
REEL CAPACITY	Up to 7" reel
HEADS	GX head for Recording × 2 GX head for Playback × 2 Erase head × 2
MOTORS	FG Servo DC motor for capstan drive × 1 DC motor for reel drive × 2
TAPE SPEED	19 cm/s ± 0.8% (7-1/2 ips.) 9.5 cm/s ± 1.0% (3-3/4 ips.)
WOW & FLUTTER	Less than 0.03% WRMS, 0.07% DIN 45500 at 19 cm/s Less than 0.04% WRMS, 0.10% DIN 45500 at 9.5 cm/s
TAPE WINDING TIME	80 sec. using 360 m (1200 ft.) tape
FREQUENCY RESPONSE (Using a EE Tape)	25 to 33,000 Hz ± 3 dB (-20 VU) at 19 cm/s 25 to 26,000 Hz ± 3 dB (0 VU) at 19 cm/s 25 to 25,000 Hz ± 3 dB (-20 VU) at 9.5 cm/s 25 to 15,000 Hz ± 3 dB (0 VU) at 9.5 cm/s
SIGNAL TO NOISE RATIO	Better than 63 dB at 19 cm/s DIN 45500
HARMONIC DISTORTION	Less than 0.5% at 19 cm/s
INPUT	Required microphone impedance: 600 ohms Line: 70 mV (input impedance 47 kohms)
OUTPUT	Line: 0.775V at 0 VU Required load impedance: more than 20 kohms Phone: 1.3 mV/8 ohms at 0 VU
DIN	Input: 2.0 mV (input impedance 10 kohms) Output: 0.3V Required load impedance: more than 20 kohms
DIMENSIONS	440(W) × 244(H) × 227(D) mm (17.3 × 9.6 × 8.9")
WEIGHT	17.0 kg (37.5 lbs)
POWER REQUIREMENTS	100V, 50/60 Hz for Japan 120V, 60 Hz for USA and Canada 220V, 50 Hz for Europe except UK 240V, 50 Hz for UK and Australia 110/120/220/240V, 50/60 Hz switchable for the other countries
POWER CONSUMPTION	JPN 30W U/T, CSA, AAL 50W

\* For improvement purposes, specifications and design are subject to change without notice.

## II. DISMANTLING OF UNIT

In case of trouble, etc. necessitating dismantling, please dismantle in the order shown in the photographs. Reassemble in reverse order.

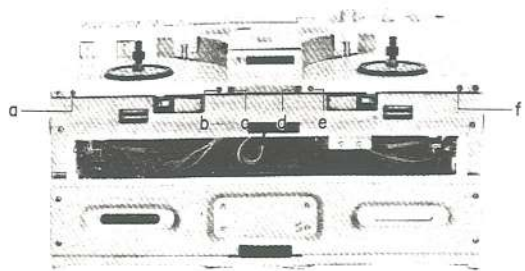
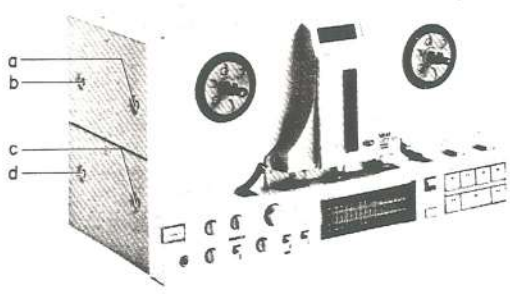
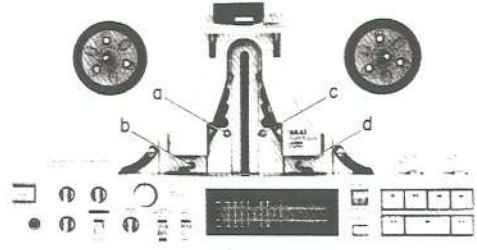
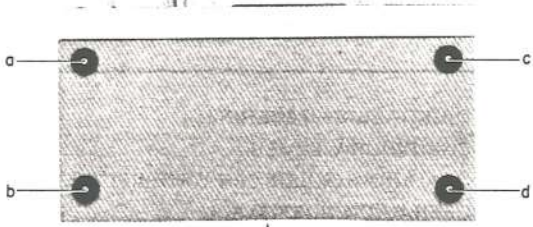
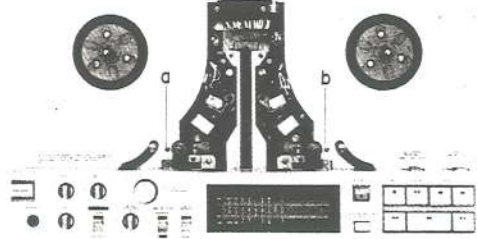
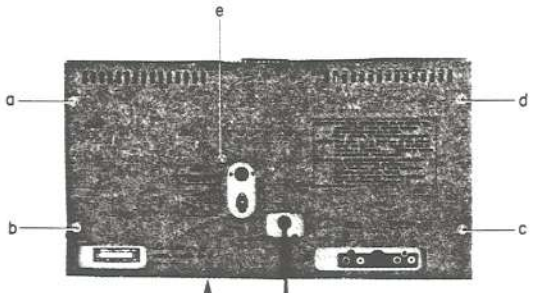
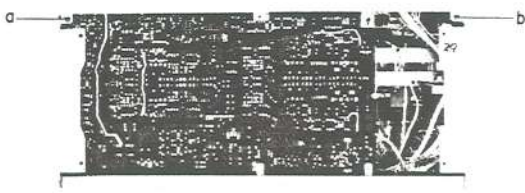
<p>1</p>  <p>SCREWS</p>	<p>5</p>  <p>SCREWS</p>
<p>2</p>  <p>SCREWS</p>	<p>6</p>  <p>SCREWS</p>
<p>3</p>  <p>BOTTOM COVER</p> <p>SCREWS</p>	<p>7</p>  <p>SCREWS</p>
<p>4</p>  <p>BACK BOARD</p> <p>SCREWS</p>	<p>8</p>  <p>SCREWS</p>

9

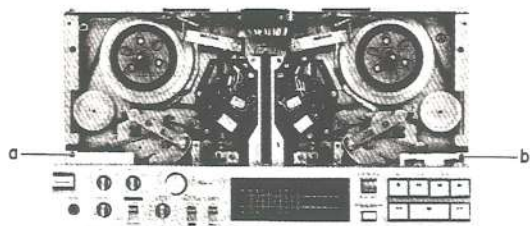

SCREWS

10

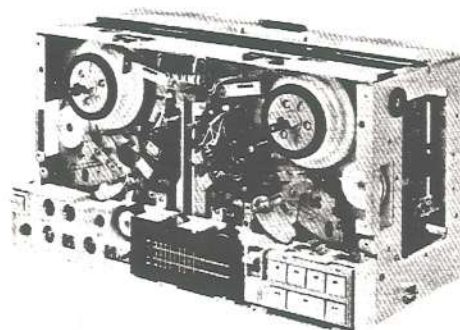

### III. CONTROLS

1. POWER SWITCH
2. SUPPLY REEL TABLE
3. REEL STOPPER
4. TENSION ARM
5. CAPSTAN
6. HEAD COVER
7. REAL TIME COUNTER and RESET BUTTON
8. PINCH ROLLER
9. TENSION ARM
10. REEL STOPPER
11. TAKE UP REEL TABLE
12. TIMER START SELECTOR
13. REVERSE (REV) SELECTOR
14. HEADPHONE (PHONES) JACK
15. OUTPUT CONTROL
16. RECORDING INPUT CONTROLS (REC-L, REC-R)
17. MONITOR SELECTOR
18. BIAS ADJUSTMENT (ADJUST) CONTROL
19. RECORDING (REC) MASTER CONTROL
20. TAPE SELECTOR
21. TAPE SPEED SELECTOR
22. DIGITAL BAR METERS
23. CUE/REVIEW LEVER
24. LOADING ROLLER UP/DOWN BUTTON
25. OPERATION BUTTONS  
 RECORDING BUTTON ( ● REC ) and INDICATOR  
 PAUSE BUTTON ( ■■ ) and INDICATOR  
 REVERSE BUTTON ( ◀ )  
 FORWARD BUTTON ( ▶ )  
 REWIND BUTTON ( ◀◀ )  
 STOP BUTTON ( ■ )  
 FAST FORWARD BUTTON ( ▶▶ )  
 STANDBY/DIRECTION INDICATORS ( ◀ and ▶ )
26. REMOTE CONTROL JACK
27. EXTERNAL POWER SUPPLY JACK  
(INPUT DC 15V 200 mA)
28. POWER CORD
29. LINE IN JACKS
30. LINE OUT JACKS
31. LOADING ROLLER
32. SENSING PINS
33. DIN JACK (Some models do not have this facility)

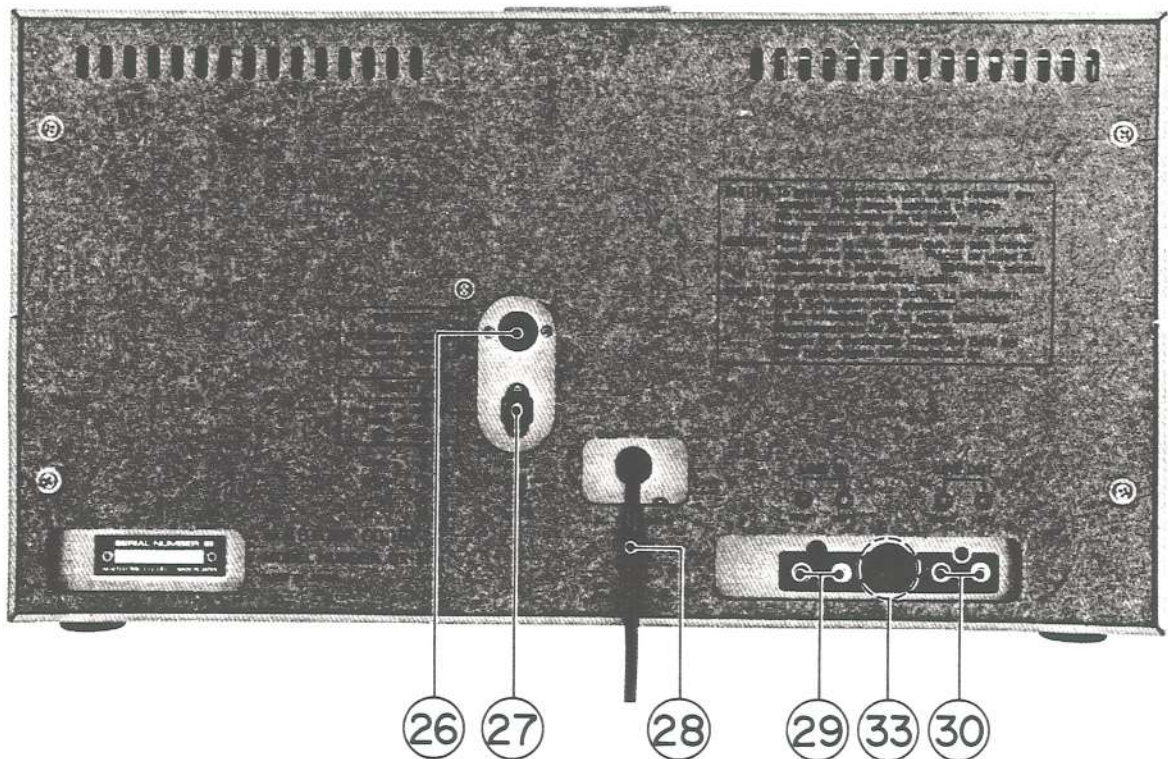
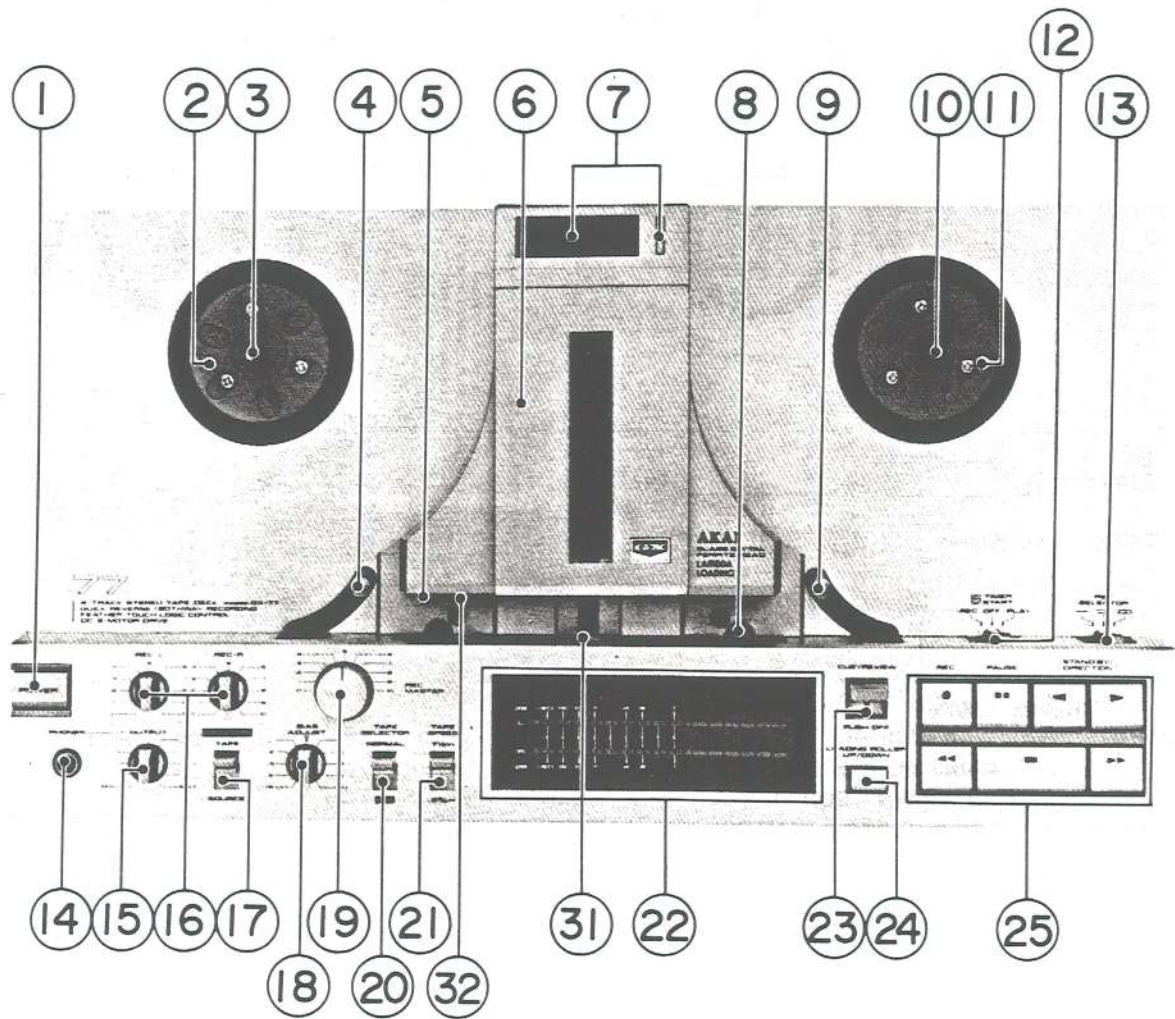

Fig. 1 Controls

# IV. PRINCIPAL PARTS LOCATION

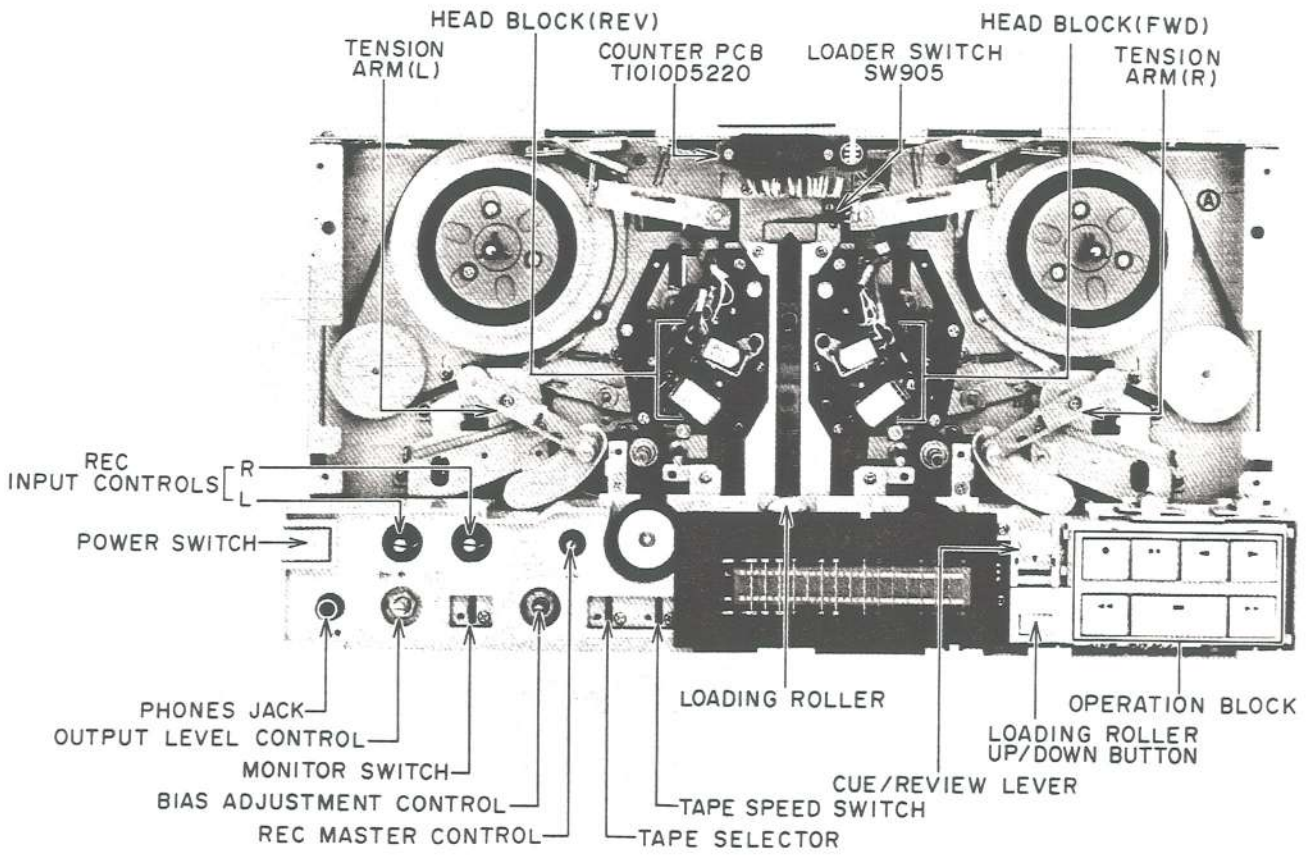

Fig. 2 Front View

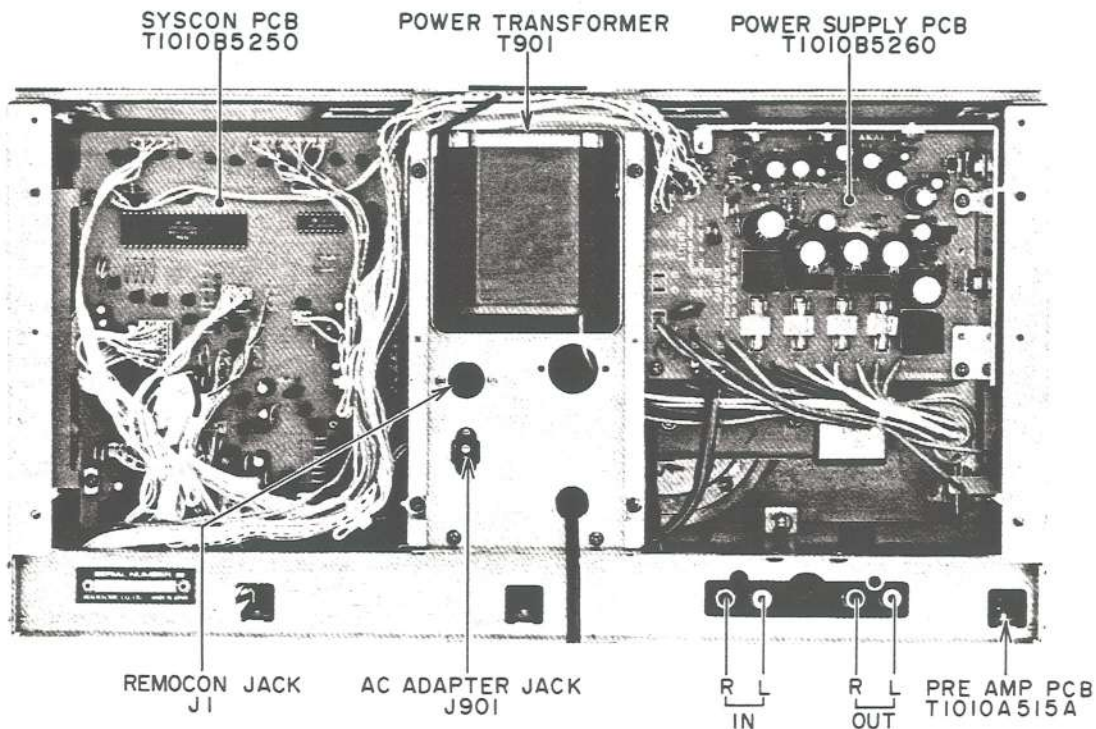

Fig. 3 Rear View



## V. VOLTAGE AND CYCLE CONVERSION

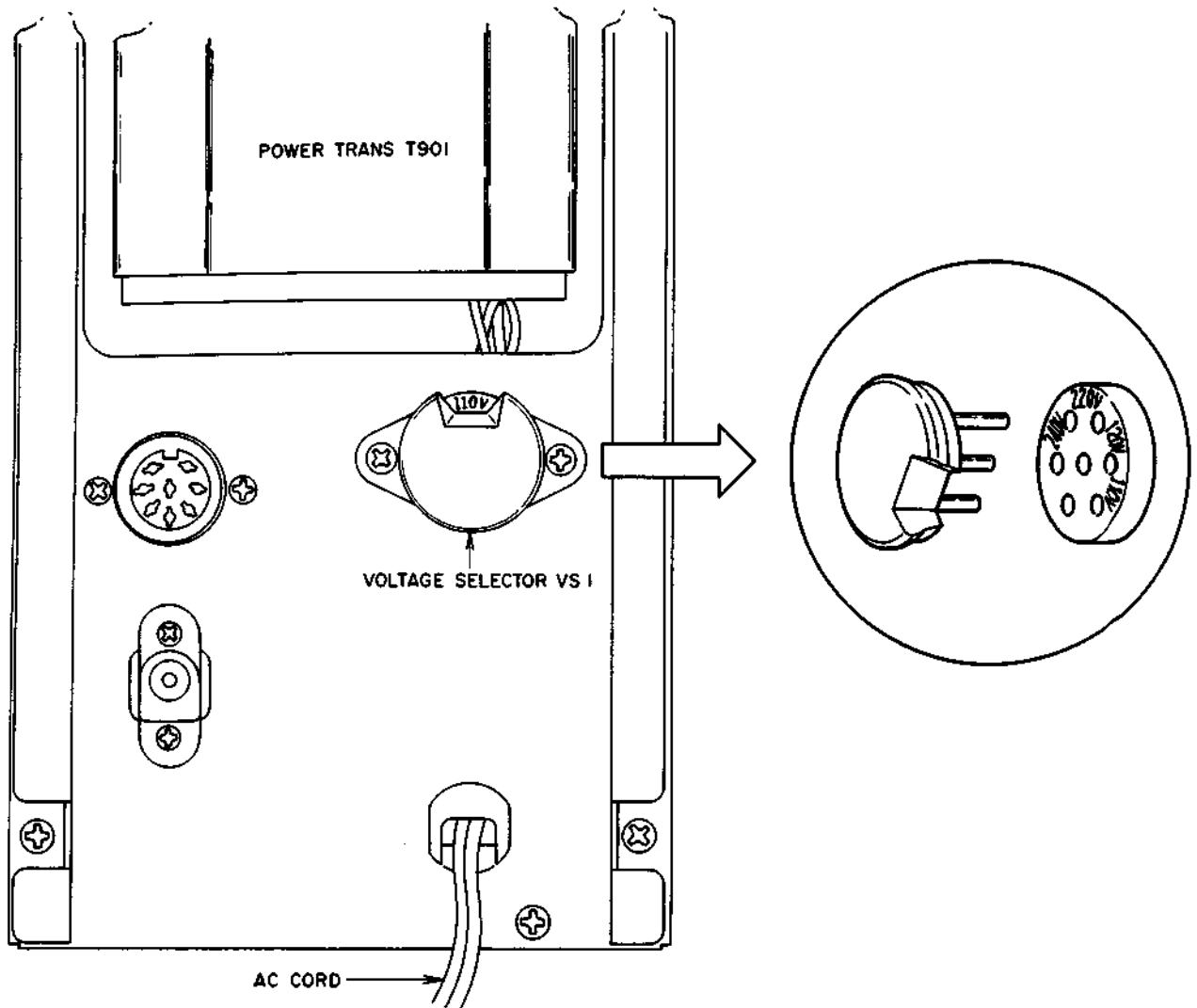

Fig. 4 Voltage Conversion (U/T Model Only)

### 1. VOLTAGE CONVERSION

Models for Canada, Europe, USA, UK, Australia and Japan are not equipped with this facility.

Each machine is preset at the factory according to destination, but some machines can be set to 110V, 120V or 240V as required.

If voltage change is necessary, this can be accomplished as follows:

- 1) Remove the back board and look for the voltage selector on the center portion of the machine.
- 2) Change the position of voltage selector plugs so that the voltage to be used coincides with the voltage shown through the opening of voltage selector plug.

### 2. CYCLE CONVERSION

With DC motor, cycle conversion is not necessary.

# VI. OPERATING PRINCIPLES

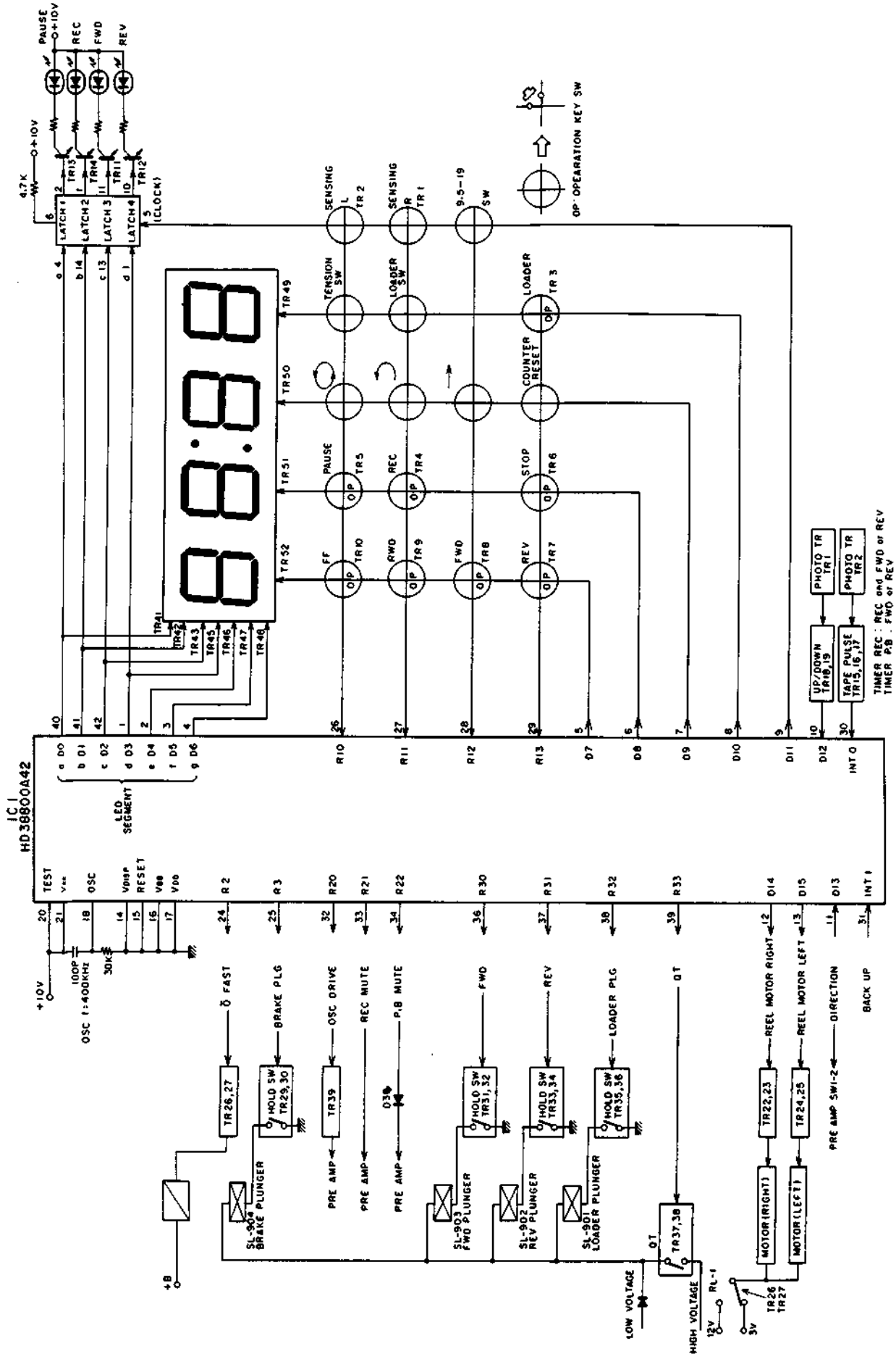

Fig. 5 Syscon Block Diagram

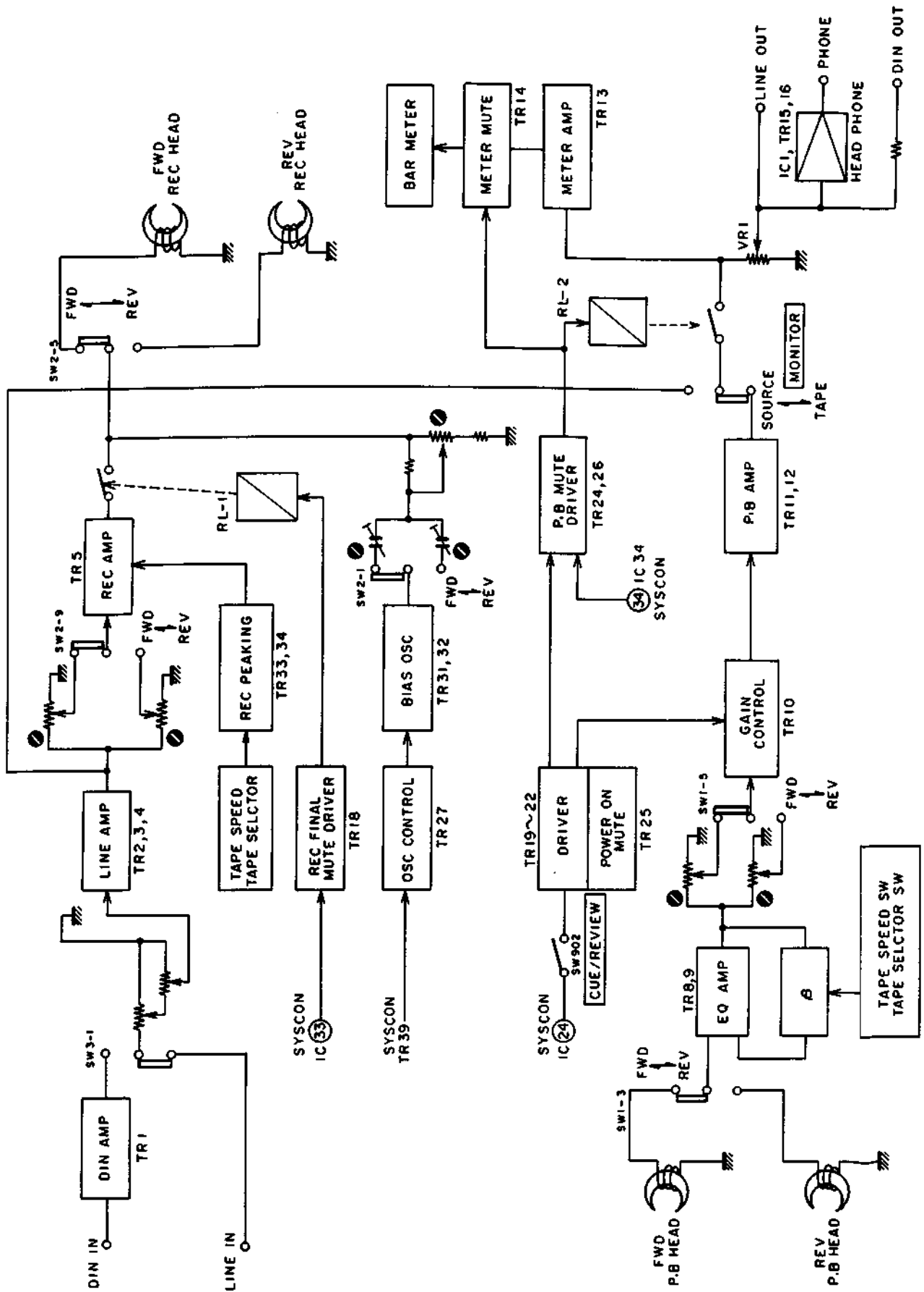

Fig. 6 Pre Amp Block Diagram

# 1. TIMING CHART OF EACH MODE

## 1) Loading, Unloading Mode (Refer to Fig. 7)

LOADING and UNLOADING do not work during FWD, FWD/REC, REV, REV/REC, FF and RWD and during loading or unloading.

The loader PLG can be pulled many times by turning the operation "loader" ON while SW905 (loader) is ON (IC1 ③⑧ will be "H").

If the loader SW is pressed, ③⑧ will be "H" for about 0.2 sec. and then, TR35, 36 ON and the loader PLG, SW905 ON and the gear of the capstan flywheel will be engaged with the loading gear, and the loading arm is lifted by the rotating

power of the loading gear, i.e., the rotating movement is changed into the linear movement. After loading, the loading gear makes one turn to return to the original position and the link-up with the flywheel will be off.

## 2) Timer Start Off (no tape) SW904 (tension off) (Refer to Fig. 8)

If the operation loader key or FWD, REV, FF or RWD is turned ON, IC1 ③⑧ becomes "H" to pull the loader PLG and then, the loader gear is rotated, SW903 (motor SW) ON, and the right and left reel motors are rotated.

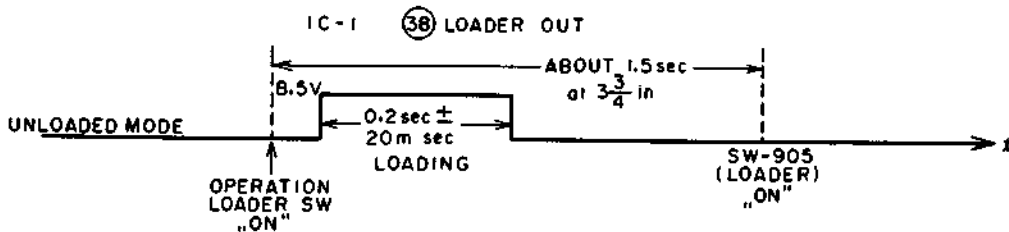

Fig. 7

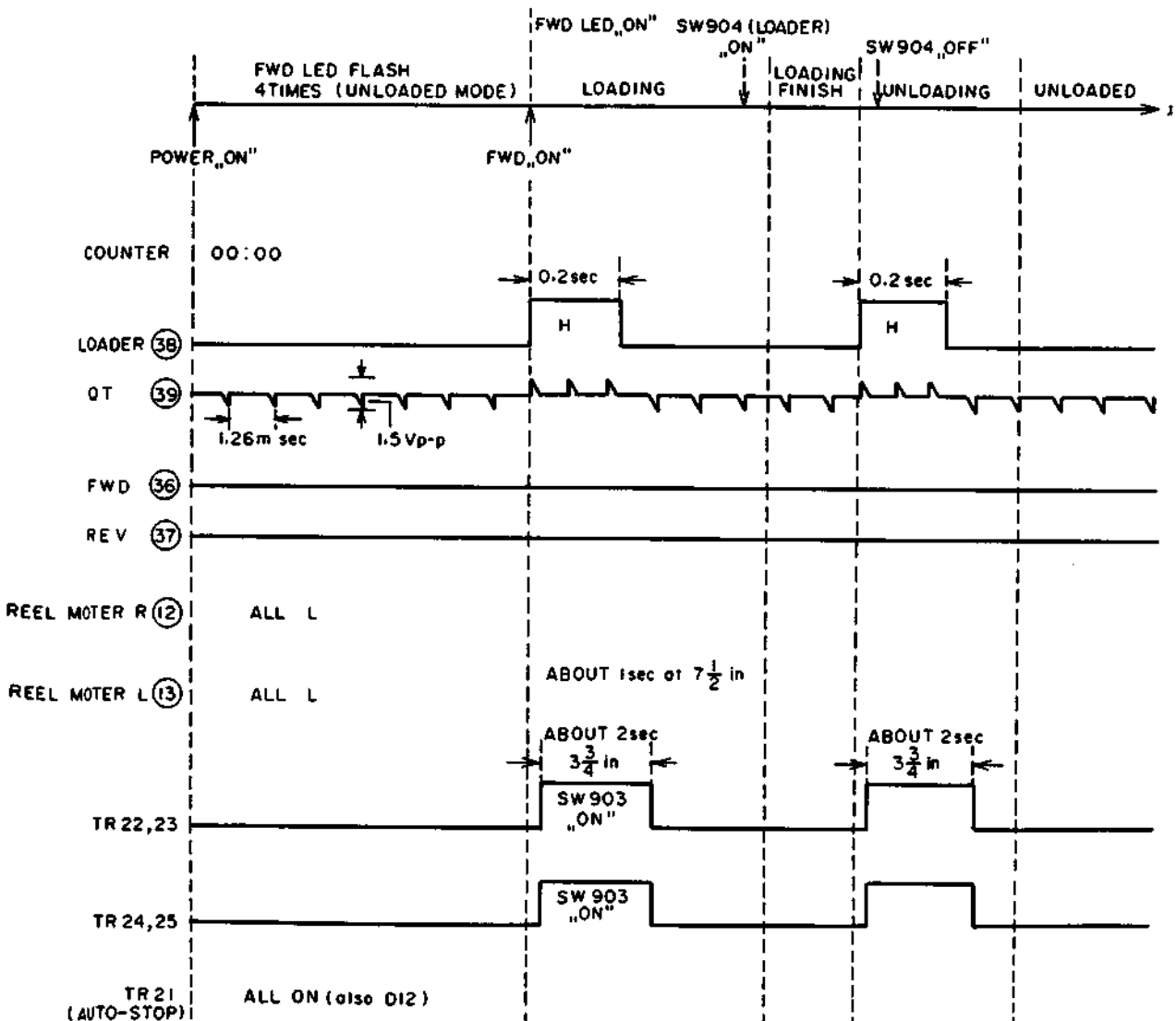

Fig. 8

3) FWD Mode (tape loaded) SW904 (tension on)

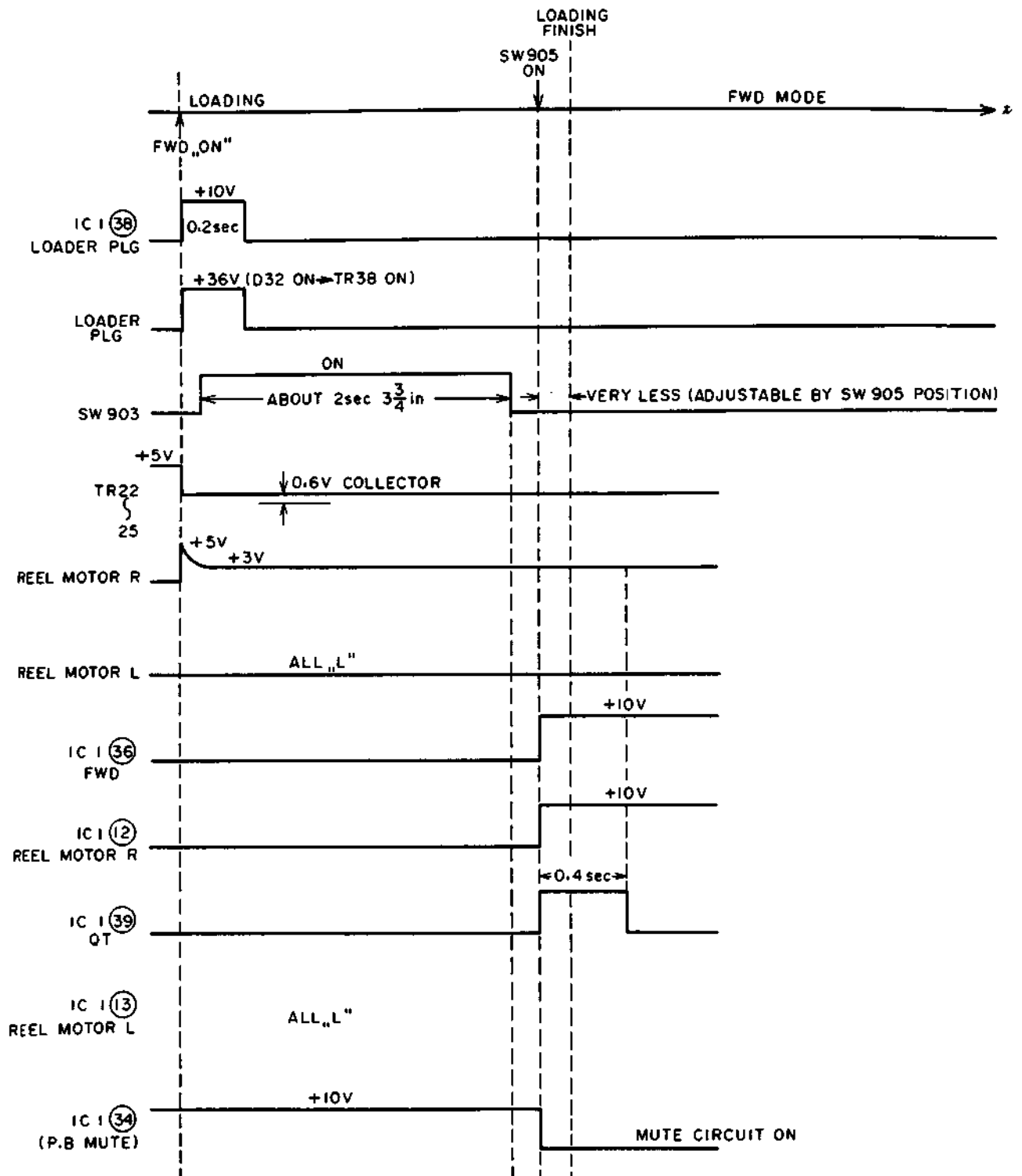

Fig. 9

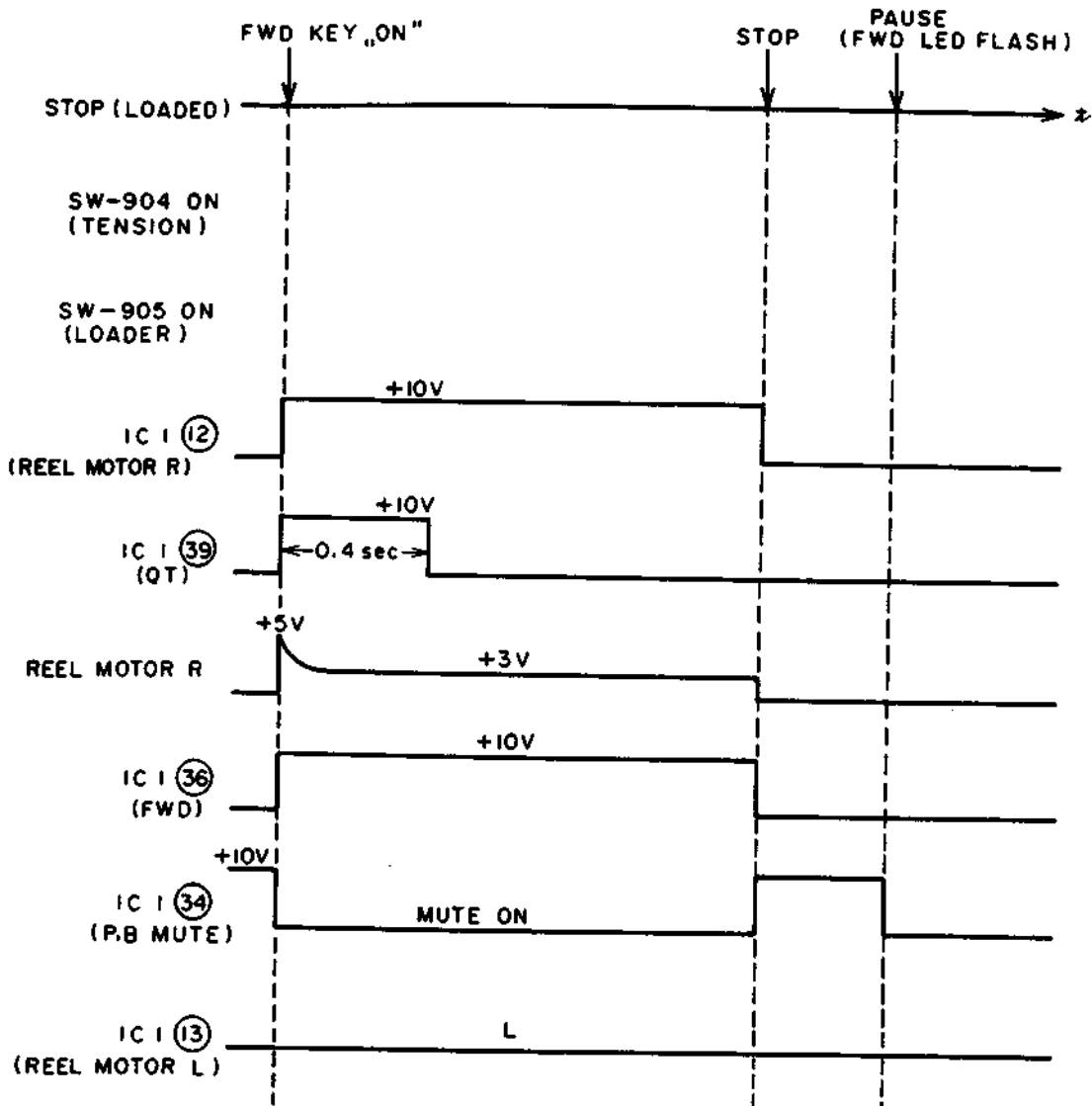

Fig. 10

#### 4) FWD Mode After Loading (Tape Loaded)

(Refer to Fig. 10)

If FWD key is turned ON after loading, ⑫ will be "H", ⑳ "H" (for 0.4 sec.), and +36V is applied to FWD PLG, and TR31, TR32 "ON", and after 0.4 sec., the voltage will be changed to +14V (because of TR38 OFF).

Because of TR22, 23 "ON", the original +5V on the right reel motor will be changed to +2.7V (due to power regulation).

The left reel motor has 0V (only mechanical tension is operated) and ㉔ will be changed from "H" to "L", and the pre amplifier MUTE is released.

#### 5) STOP → FWD → REV → PAUSE Mode

(Refer to Fig. 11)

For FWD to REV, ㉓ (QT relay) becomes "H" for 0.4 sec., TR37 "OFF" and TR38 "ON", and +36V is applied to each plunger.

After 0.4 sec., TR38 becomes "OFF", and +14V is applied to each plunger. For each reel motor, the first +5V and then reduced to +2.7V in FWD and REV mode.

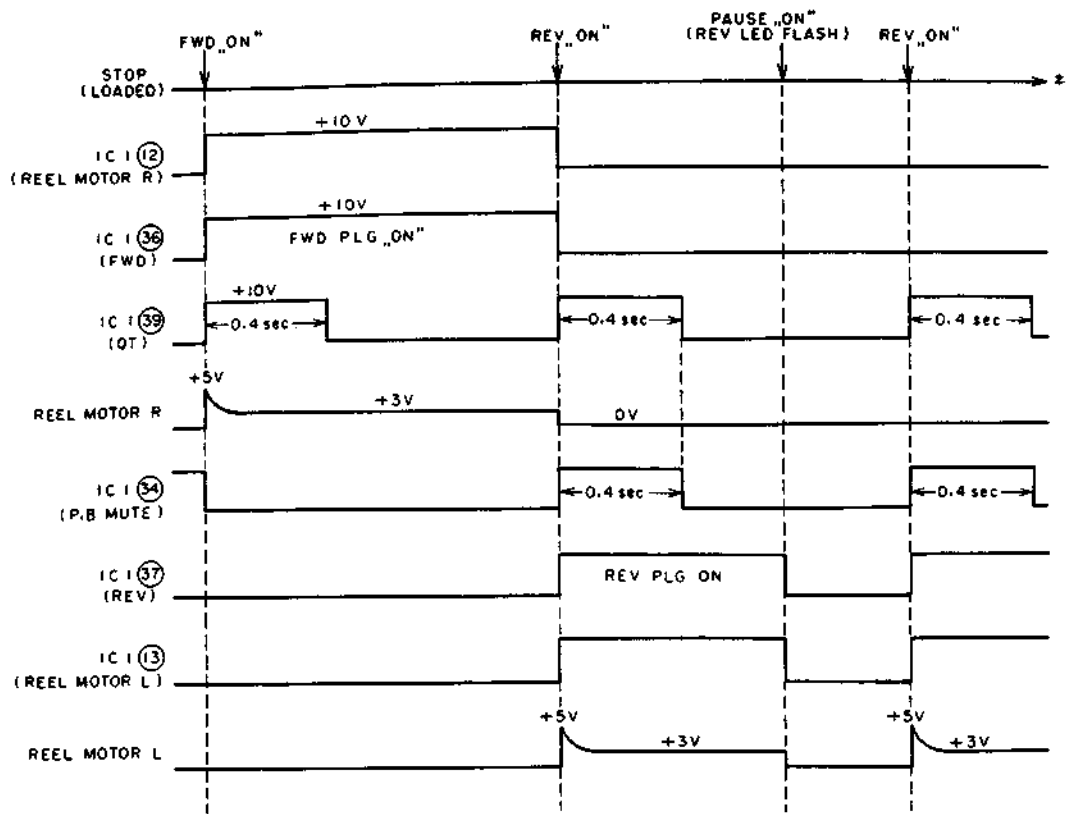

Fig. 11

6) REC/FWD → REC/REV → REC/REV/PAUSE Mode

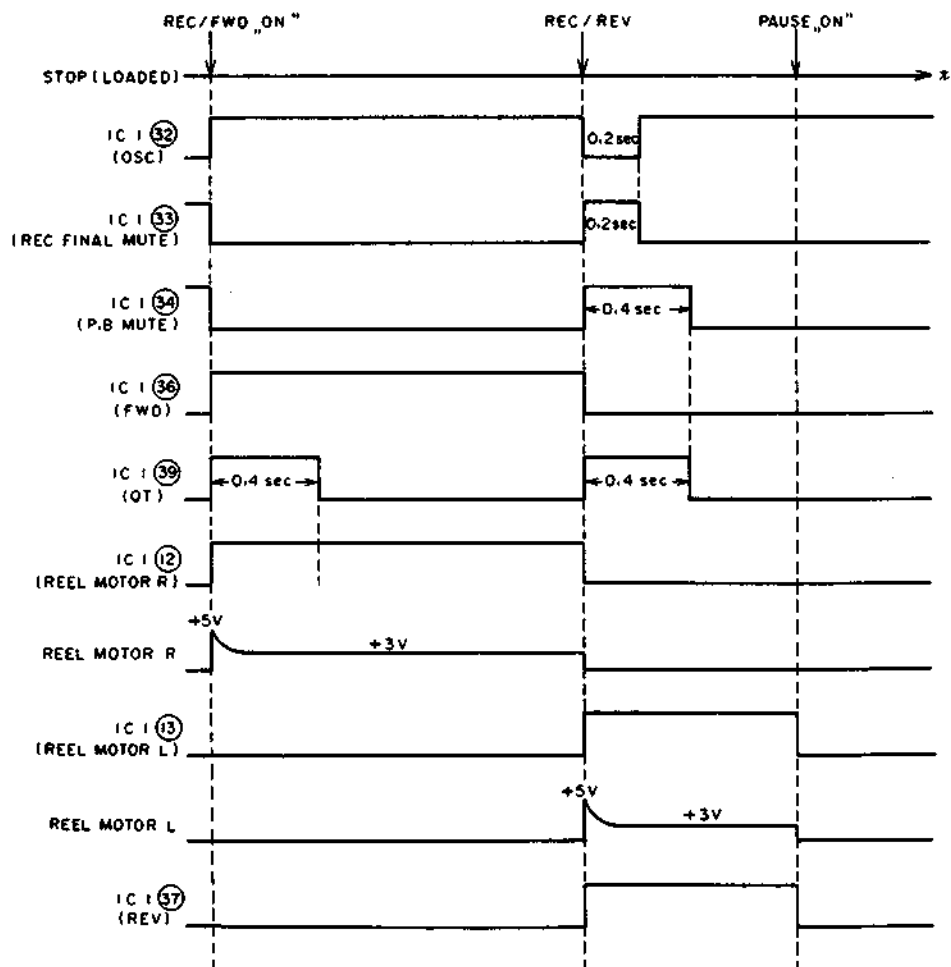

Fig. 12

7) STOP → FF → RWD Mode

If, in FF and RWD, ②④ ( $\bar{O}$  FAST) becomes "H", TR26 and 27 "ON" and RL1 "ON", and +12V

is applied to each reel motor. For the brake PLG, ③⑨ (QT relay) is "H" for 0.4 sec. and during the time, +36V and then reduced to +14V.

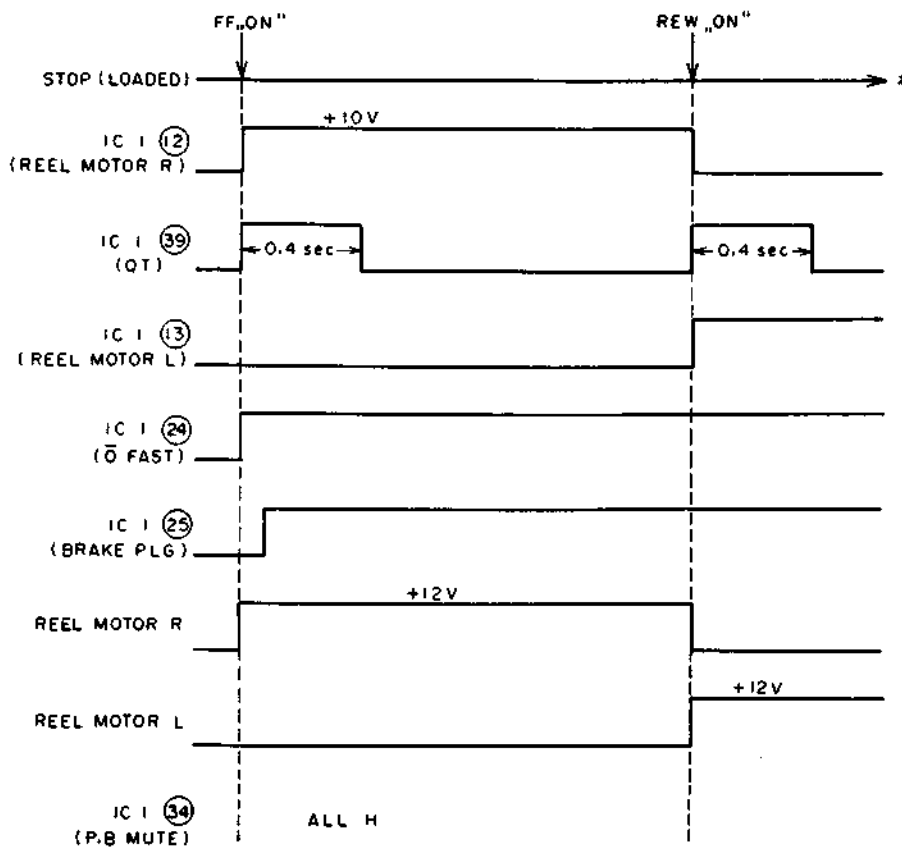

Fig. 13

8) FF → FWD Mode

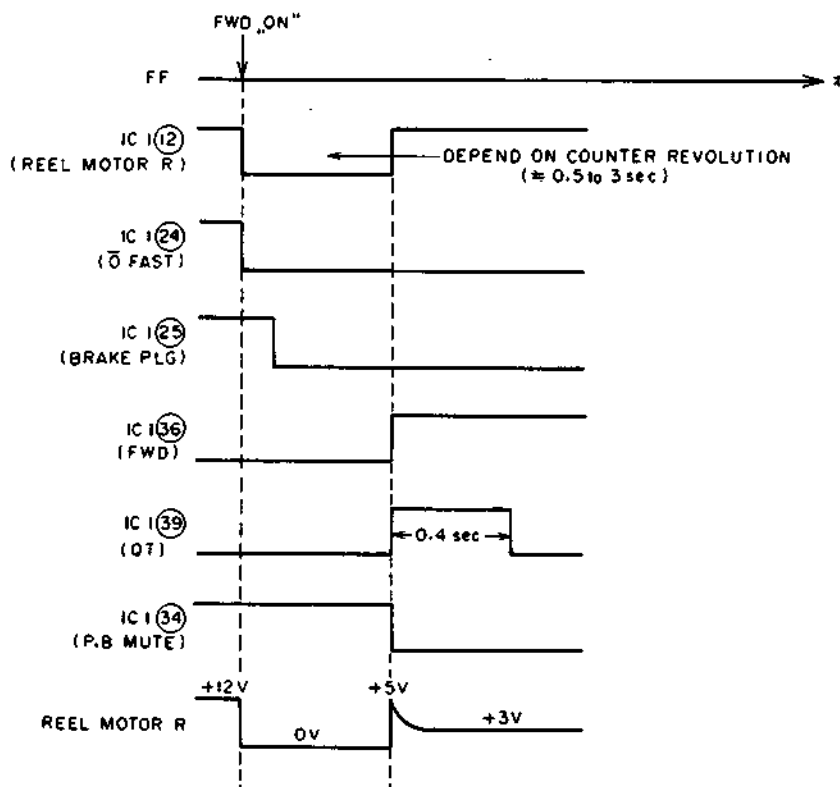

Fig. 14



9) Timer Start  
a) OFF Mode

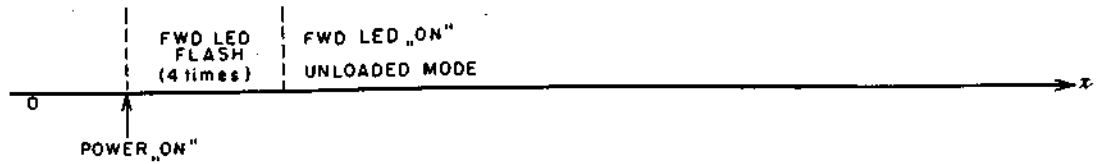

Fig. 15

b) PLAY Mode

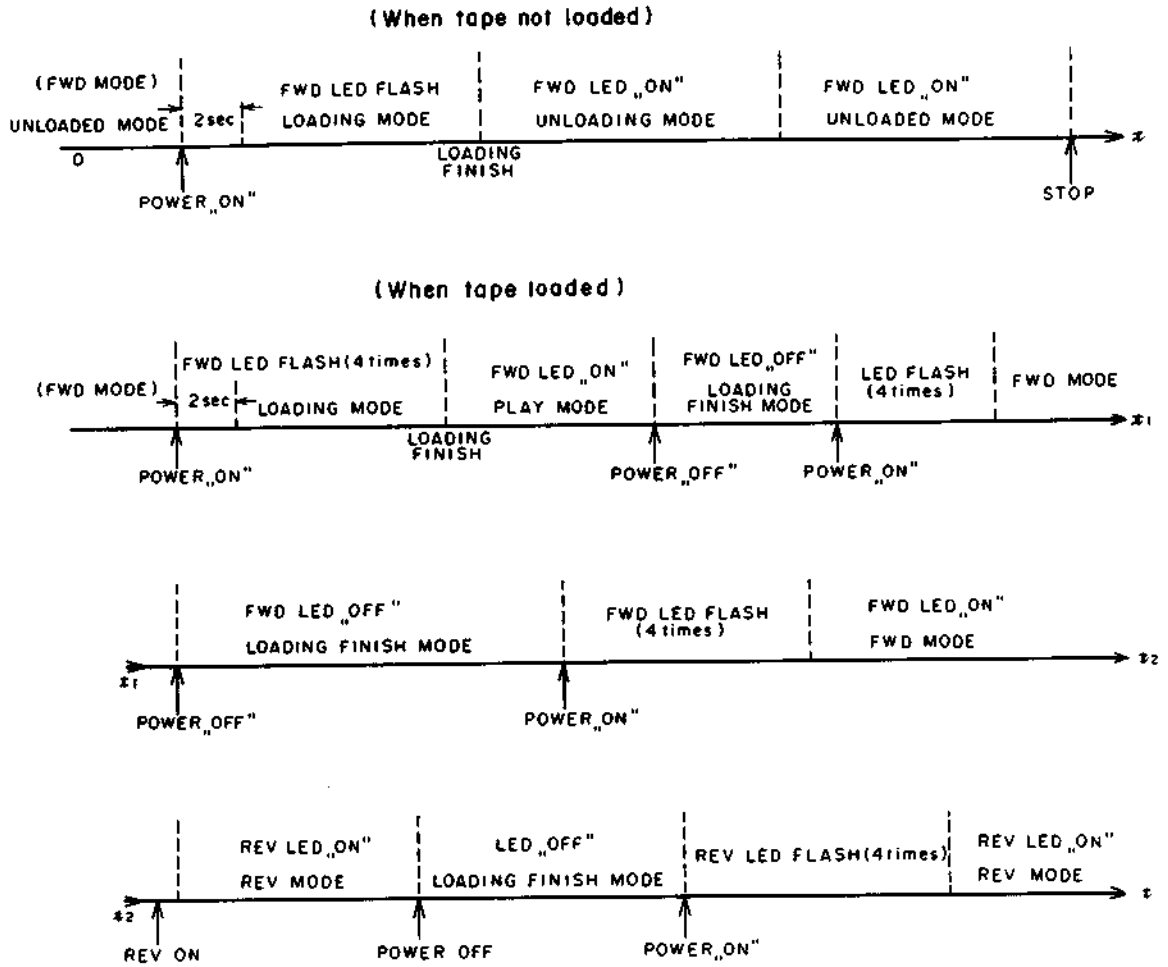

Fig. 16

c) REC Start Mode

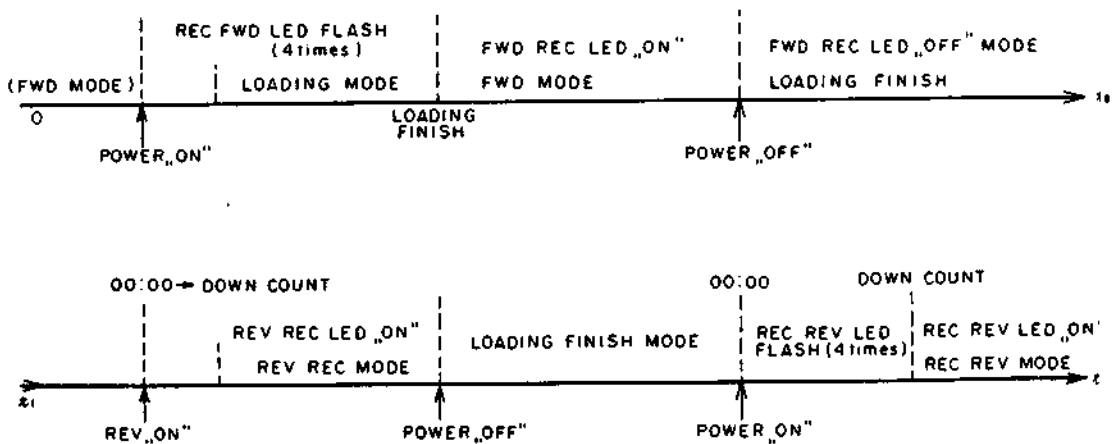

Fig. 17

## 2. EXPLANATION OF EACH MODE

### 1) ICI (HD38800A42) Terminal Description

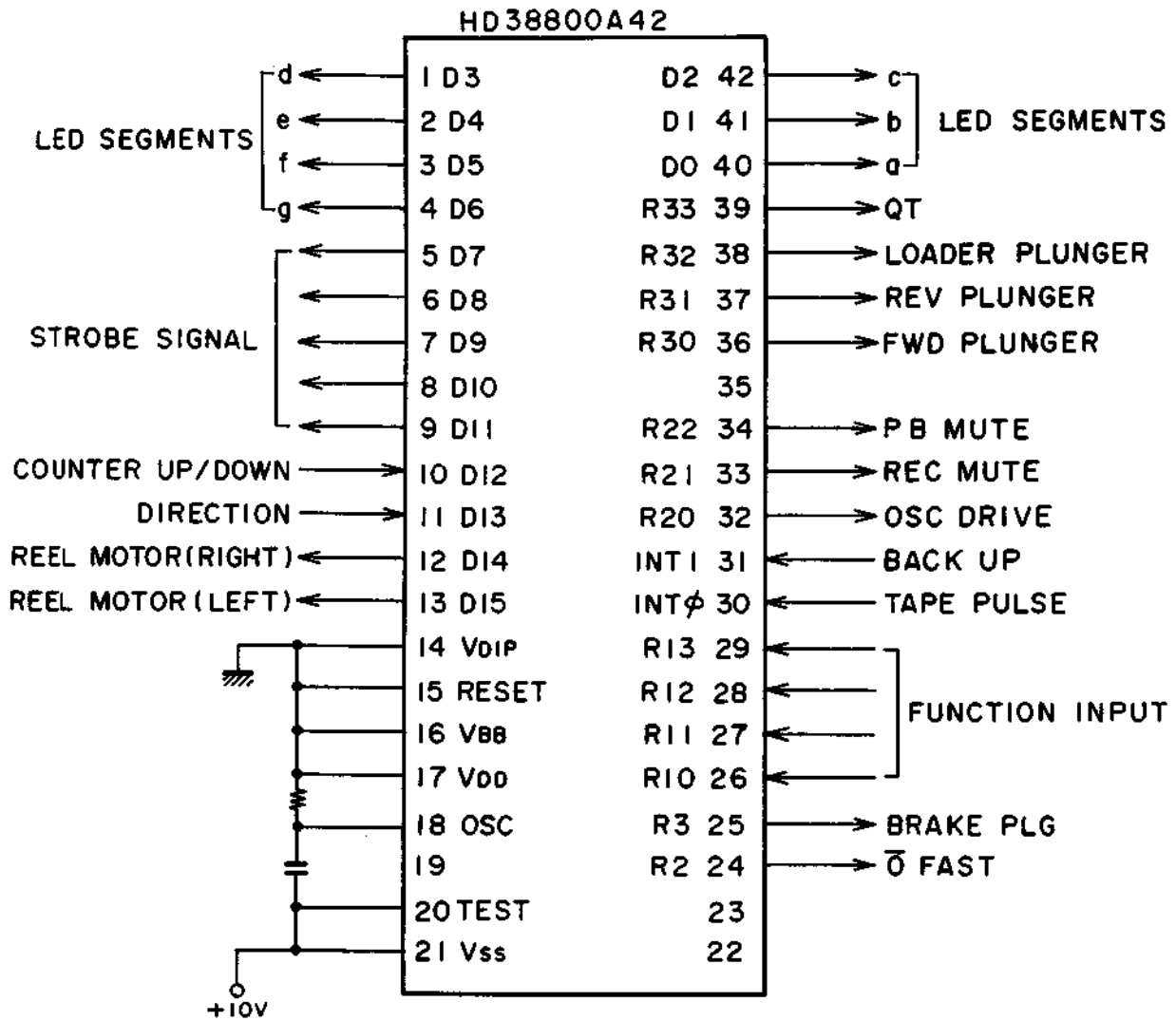

Fig. 18

## 2) Terminal Conditions in Each Mode

IC-1 PIN NUMBER	(38) LOADER	(39) QT	(36) FWD	(37) REV	(12) REEL MOTOR R	(13) REEL MOTOR L	(34) RB MUTE	(32) OSC	(33) REC MUTE	(24) $\bar{O}$ FAST	(25) BRAKE PLUNGER
STOP	L	L	L	L	L	L	H	L	H	L	L
LOADING	H(M)	L	L	L	L	L	H	L	H	L	L
FWD	L	H(M)	H	L	H	L	L	L	H	L	L
REV	L	H(M)	L	H	L	H	L	L	H	L	L
FWD/PAUSE	L	L	L	L	L	L	L	L	H	L	L
REV/PAUSE	L	L	L	L	L	L	L	L	H	L	L
REC/FWD	L	H(M)	H	L	H	L	L	H	L	L	L
REC/REV	L	H(M)	L	H	L	H	L	H	L	L	L
REC/FWD/PAUSE	L	L	L	L	L	L	L	H	L	L	L
REC/REV/PAUSE	L	L	L	L	L	L	L	H	L	L	L
FF	L	H(M)	L	L	H	L	H	L	H	H	H
RWD	L	H(M)	L	L	L	H	H	L	H	H	H
UNLOADING	H(M)	L	L	L	L	L	H	L	H	L	L

\* M . MOMENTALY

Fig. 19

## 3) Output Waveforms of ICI Terminals ⑤ to ⑨

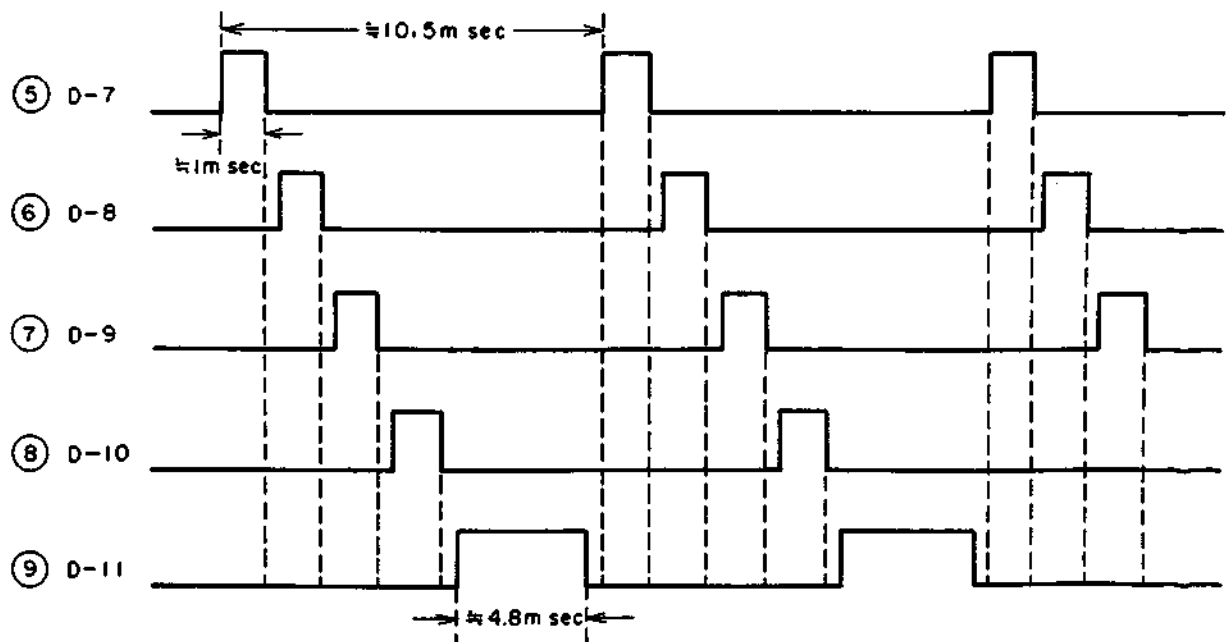

Fig. 20

#### 4) Power ON

Without any input conditions (such as operation key is not pressed) through the built-in reset circuit, IC1 performs no operation. (In order to meet the conditions for the operation of the built-in reset circuit, 3 terminal regulator is used only for the IC1 power source)

#### 5) Loading Mode After Power ON

If the loading operation SW, etc. is pressed, the output of IC1 ⑧ enters ⑳ through TR3, and ㉑ (loader plunger) changes from "L" to "H" ( $\approx 10V$ ) for 0.2 sec., TR35 and 36 "ON" and TR37 and 38 ON through D32, and +36V is added to the loader plunger. Because the loader plunger is ON for about 0.2 sec., the loading gear starts rotating via the capstan flywheel, and the motor SW (SW903) interlocked with it will be ON until the gear finishes one turn, and then TR22 to TR25 ON, and the voltage (+5V under no load, +3V after motor loading) is added to the right and left reel motors which turn in the respective winding direction. Thus the tension is added to the tape to prevent sagging even if the mechanical brake interlocked with the loading gear is released during loading.

The completion of loading is detected by SW905, i.e., the next operation is not available until the SW905 is ON.

#### 6) FWD Mode After Loading

With FWD key ON, the output of IC1 ⑤ is inputted into ㉒ and ㉓ "L"  $\rightarrow$  "H", ㉔ "L"  $\rightarrow$  "H", and then TR31, 32 ON, TR 22, 23 ON, and the right reel motor rotates, FWD plunger is also ON and the right pinch roller is pulled. The right and left brakes mechanically interlocked with the FWD plunger are released. The supply back tension is added to the reel table by the brake pad interlocked with the supply tension arm. (The supply motor rotates freely). ㉕ (QT) is also ON for 0.4 sec. and +36V is added to the plunger  $\rightarrow$  subsequently held at +14V.

With ㉖ (P.B. Mute) "H"  $\rightarrow$  "L", Mute will be off.

#### 7) REV Mode (reverse operation to FWD)

- IC1 ⑬ "H"  $\rightarrow$  left reel motor rotates
- ㉗ "H"  $\rightarrow$  FWD plunger ON
- ㉘ "H" (for 0.4 sec.)  $\rightarrow$  +36V  $\rightarrow$  +14V
- ㉙ "L"  $\rightarrow$  Mute Off.

#### 8) FF Mode

IC1 ㉚ ( $\bar{O}$  FAST) "L"  $\rightarrow$  "H", TR26, 27 ON, RL1 ON, and +12V is added to the reel motor, ㉛ (right motor) "L"  $\rightarrow$  "H", TR22, 23 ON, and the right reel motor rotates at a high speed. ㉜ (brake plunger) "L"  $\rightarrow$  "H", TR31, 32 ON, brake PLG ON, and the supply motor rotates freely (the reel table is only receiving mechanical free tension). ㉝ (PB Mute) is fixed at "H" and the line output is cut off.

#### 9) RWD Mode (reverse operation to FF)

- IC1 ㉞ ( $\bar{O}$  FAST) "L"  $\rightarrow$  "H", RL1 ON, +12V applied
- ㉟ (brake plunger) "L"  $\rightarrow$  "H", brake released
- ㊱ (left motor) "L"  $\rightarrow$  "H", left reel motor rotates at high speed.
- ㊲ (PB Mute) fixed at "H", and line output cut off.

#### 10) FWD/REC Mode

With the input IC1 ⑤  $\rightarrow$  ㉚ and at the same time IC1 ⑥  $\rightarrow$  ㉗, the output of IC1, with FWD mode output, ㉛ "L"  $\rightarrow$  "H", TR39 ON, operates the OSC circuit of the preamplifier. ㉜ "H"  $\rightarrow$  "L", preamplifier TR17 OFF, TR18 ON, RL1 (Rec Mute Relay) ON, and the preamplifier REC input signal is added to the Rec head. ㉝ "H"  $\rightarrow$  "L" and PB Mute released.

#### 11) FWD, REV Direction (Refer to Fig. 21)

SW1 - 2 (Pre Amp PCB) Signal from REV  $\rightarrow$  FWD SW.

If IC1 ⑪ is "L" (REV mode), IC1 will be in REV STANDBY mode, i.e., when IC1 ① is ON, "L"  $\rightarrow$  "H"  $\rightarrow$  "L" is repeated 4 times  $\rightarrow$  (REV LED flashes 4 times) and then fixed at "H"  $\rightarrow$  (LED "ON"). (See the description of lighting circuit operation).

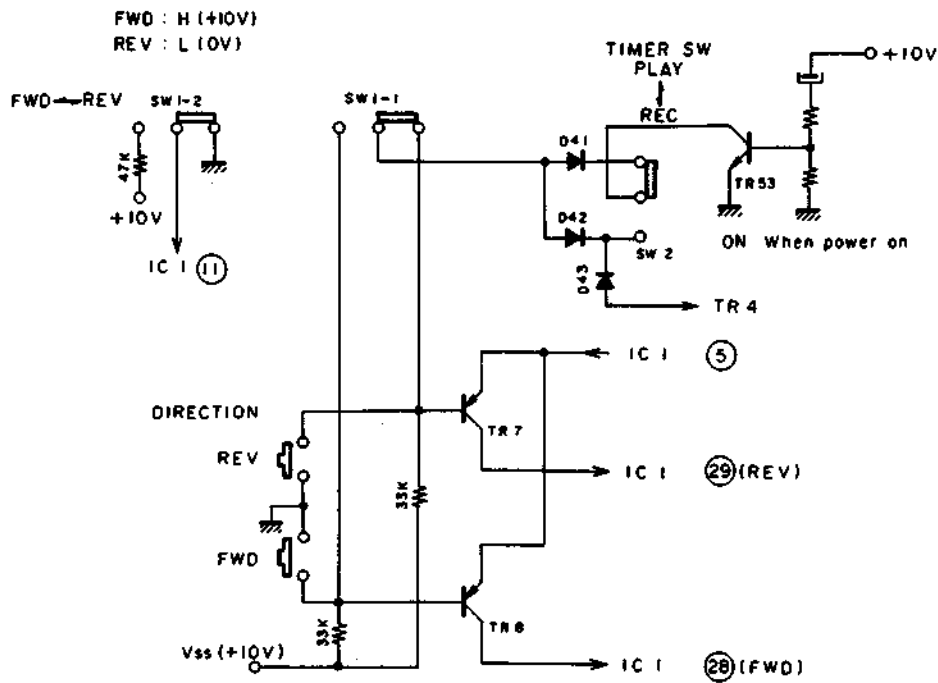

Fig. 21

### 3. EXPLANATION OF EACH CIRCUIT

1) Circuit to Prevent Tape Sagging When Power is ON  
 +14V → REV, FWD PLG → C5, C6 → D19, D18 →  
 R56, R58 → TR22, 24 runs the charging current,

and in the meantime, the right and left reel motors are energized to prevent the tape from sagging (Brake is also mechanically on the reel table).

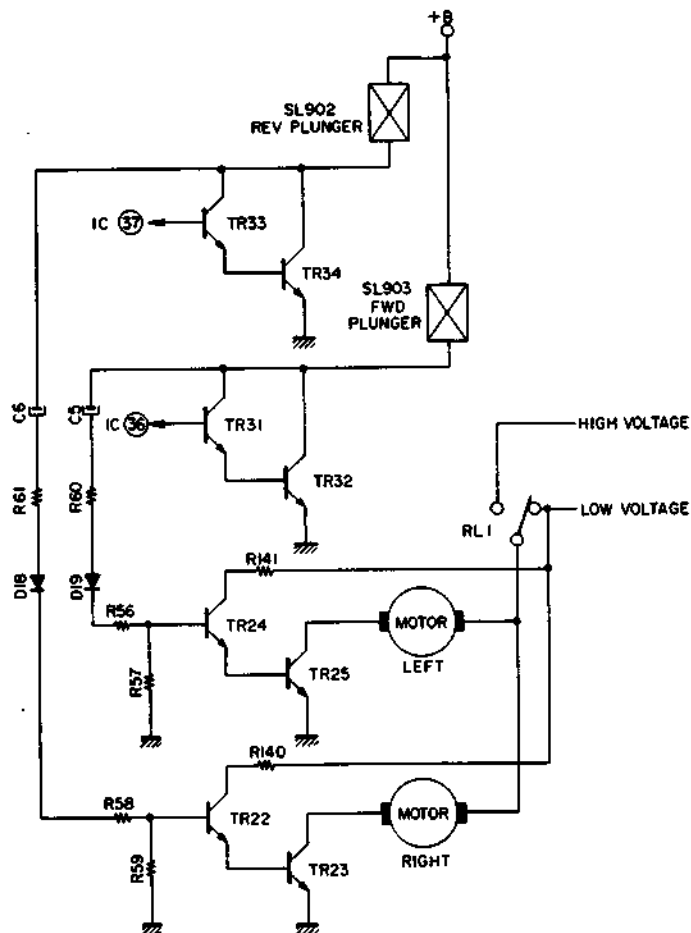

Fig. 22

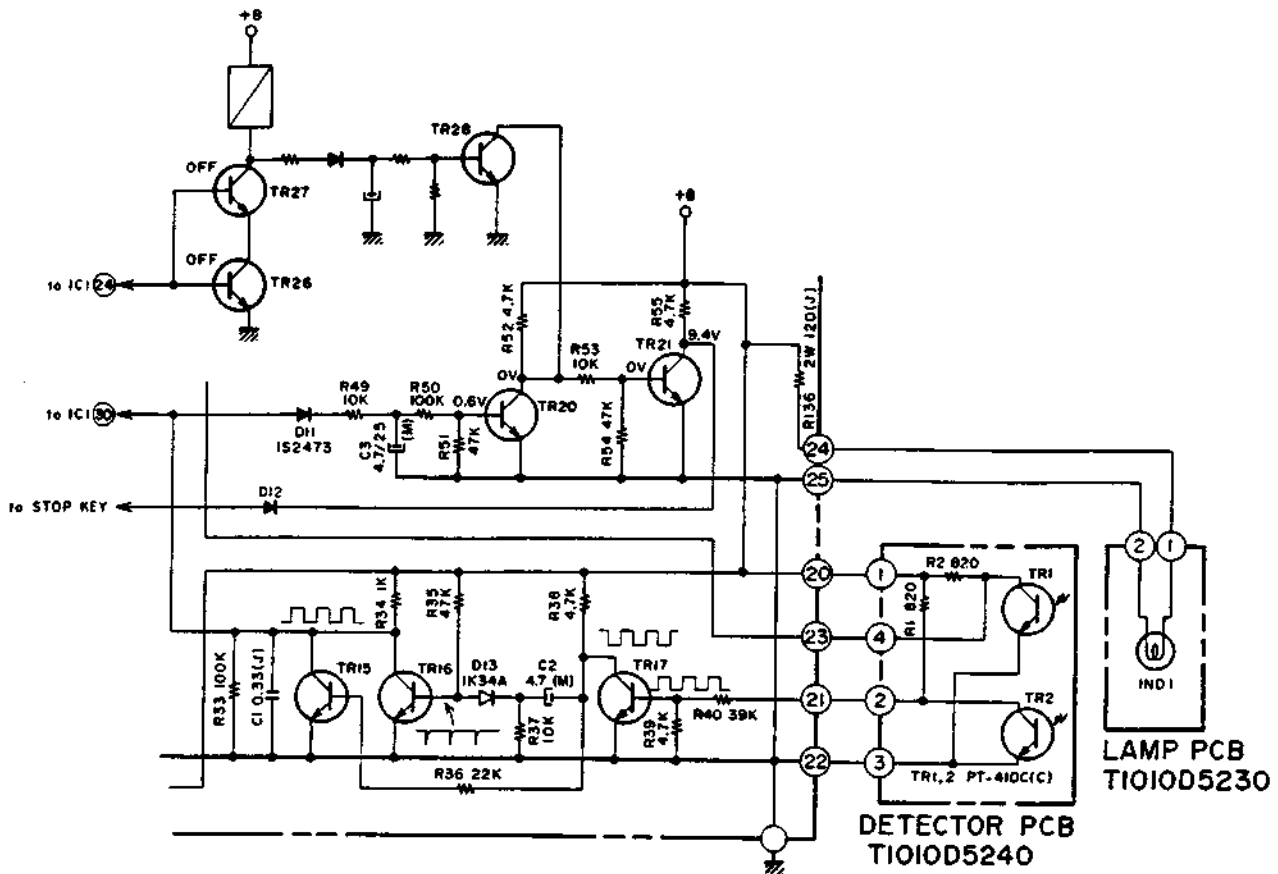

Fig. 23

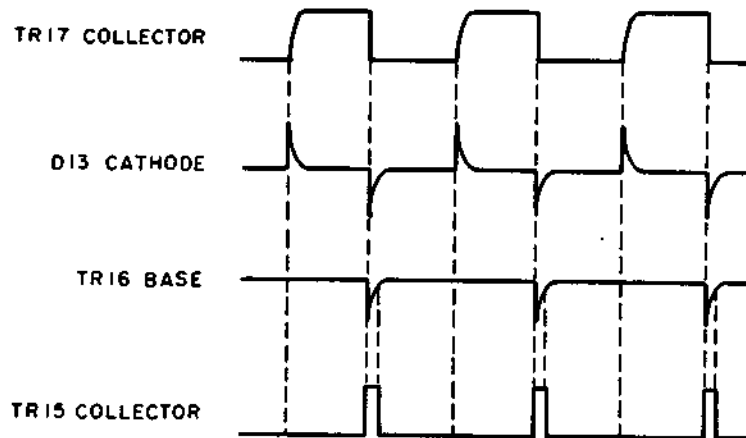

Fig. 24

**2) Auto Stop Circuit (Refer to Figs. 23, 24)**

Photo TR (TR2) is repeating ON/OFF when the tape is running.

The pulse of TR15 collector is added to IC1 ③ and TR20 base.

TR20 collector is connected with TR28 collector, and while TR28 base is "H", TR21 is "OFF", i.e., no auto-stop. In FWD and REV, the auto-stop functions when the tape is winder up by the take-up reel, tension arm (right) is lowered, and micro SW SW904 is shut off. In FF and REW,

same as in FWD and REV, the auto-stop works about 4 seconds after the micro SW SW904 is shut off and the tape pulse is gone.

In FWD, REV and FF, REW, the positions of TR28 and D12 are as follows.

FWD, REV	→	FF, REW
TR28:	ON (Always)	ON → OFF
D12 :	OFF (Always)	ON about 4 seconds after tape pulse disappears

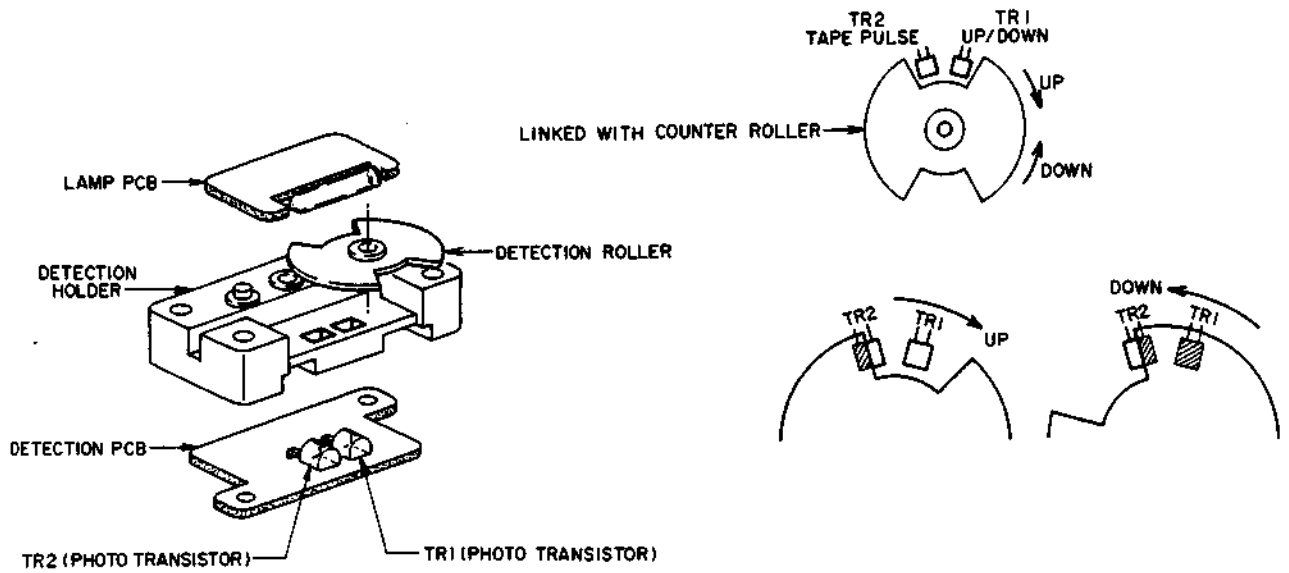

Fig. 25

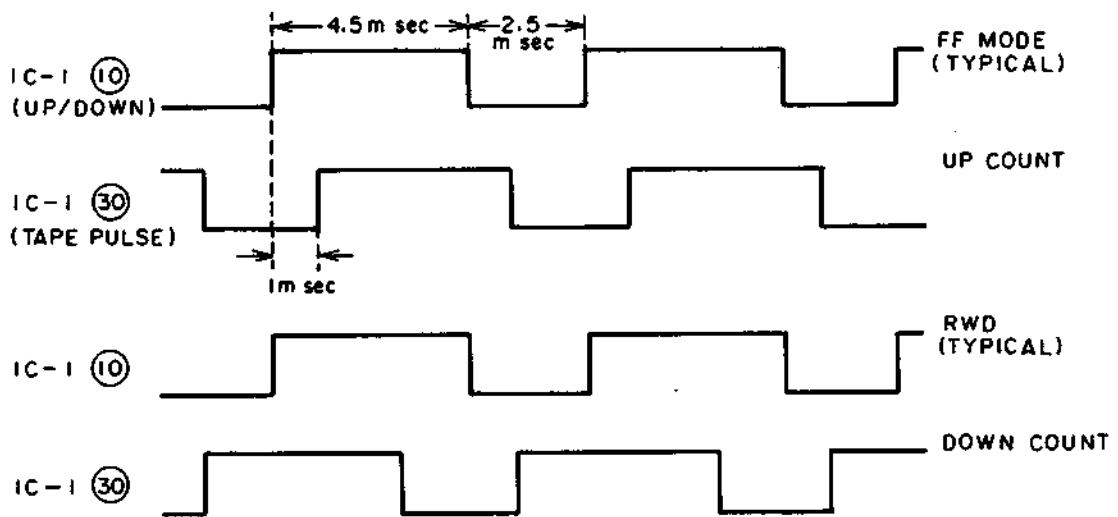

Fig. 26

### 3) COUNTER Operation (Refer to Figs. 25, 26)

The output of TR1 is inputted into IC1 D12 ⑩ after waveform shaping in the Schmitt Circuit of TR18 and TR19. The output of TR2 is inputted into IC1 ③① after waveform shaping in TR15 to TR17, and depending on the phase relation, it conducts UP or DOWN count. (For the waveform of TR15-17, see auto-stop circuit).  
 Input waveforms of IC1 ⑩, ③① (Counter Circuit)

#### 4) Function Mode Indicator Indication Circuit

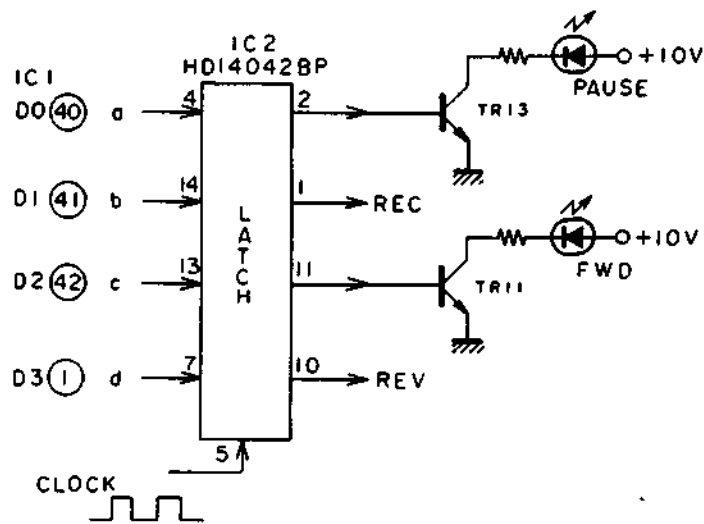
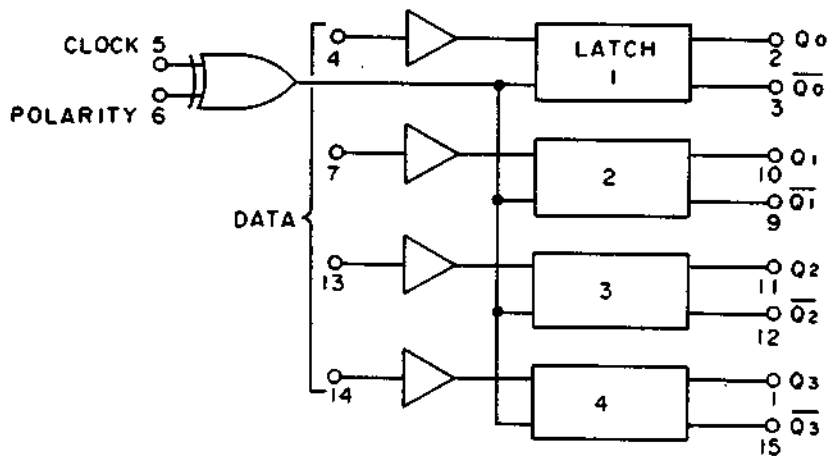

Fig. 27

#### IC2 (HD14042BP) Quad Latch



CLOCK	POLARITY	Q
L	L	DATA
	L	LATCH
H	H	DATA
	H	LATCH

} Use Only This Condition

Fig. 28



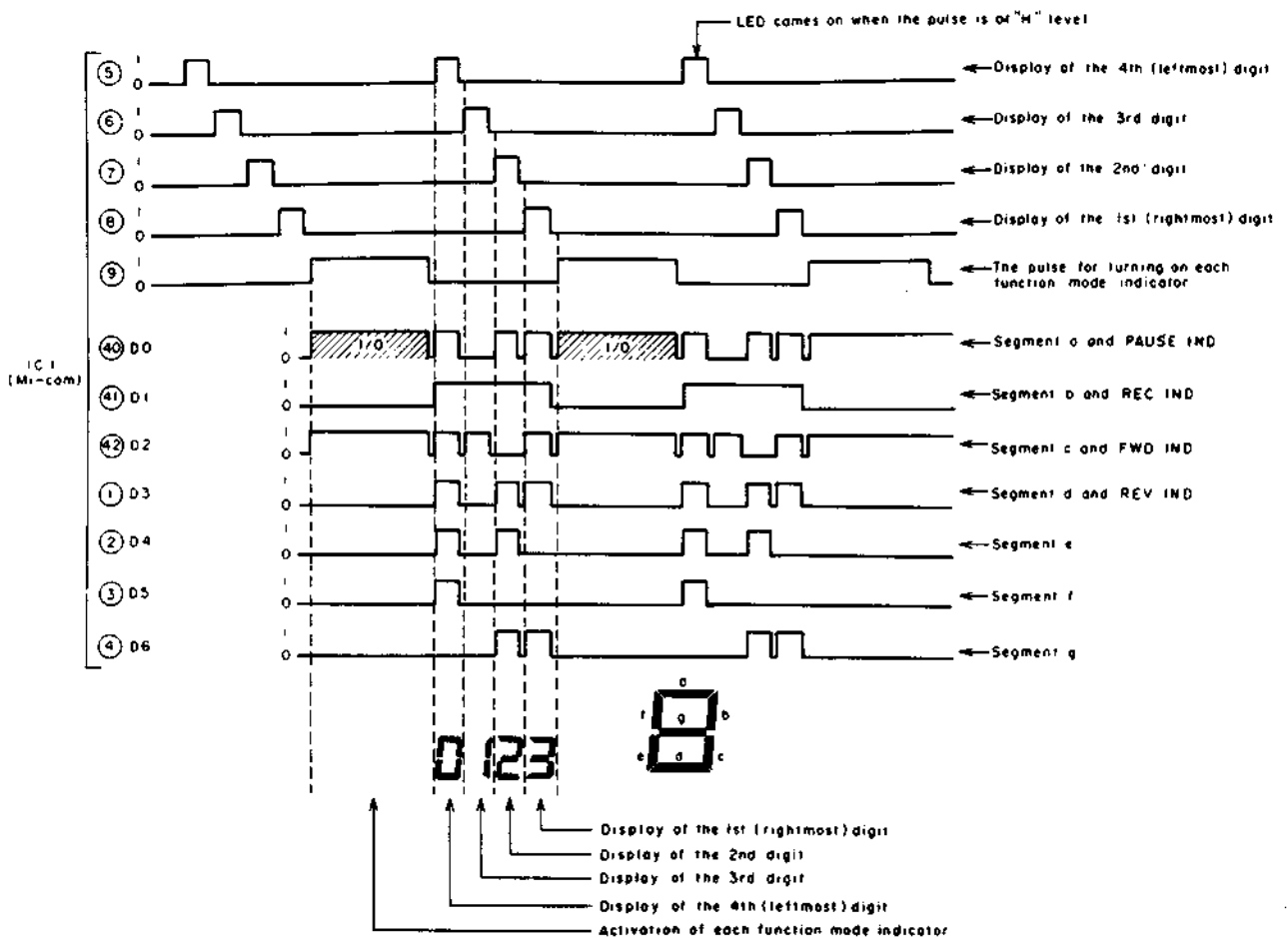

Fig. 29

Also the function mode indicators are lighted up by the operation timing of the control signal from the microcomputer. Here, we take the example of FWD PLAY/PAUSE in Fig. 29. FWD PLAY shall be called simply as PLAY hereinafter. In PLAY/PAUSE mode, the function mode indicator, PAUSE is always lighted and PLAY is flashing. Firstly look at the longitudinal row of the function mode indicators of D0 ~ D3 in Fig. 29.

You will see that PAUSE IND is "H" level, PLAY IND is "L/H" flashing and others are "L" level. (D0 ~ D3) and IC1 ⑨ signals are inputted into the latch circuits of ④, ⑦, ⑬, ⑭ and ⑮ of

IC2 in Fig. 27.

The latch circuit is shown in Fig. 28, and in such case, since IC2 ⑥ polarity is always "H", data is always "H", data is outputted when the clock is "H", and when it is "L", the data latched and held is outputted.

Therefore, in FWD PLAY/PAUSE, when the clock signal of IC1 ⑨ is "H", the PAUSE indicator is "H" and FWD IND is "L/H" flashing, and "H" signal appears in IC2 ② in Fig. 27 to turn TR13 ON and flashes PAUSE IND, and in IC2 ⑩, "L/H" flashing signal appears to turn TR11 ON and OFF and flashes FWD IND.

## VII. MECHANISM ADJUSTMENT

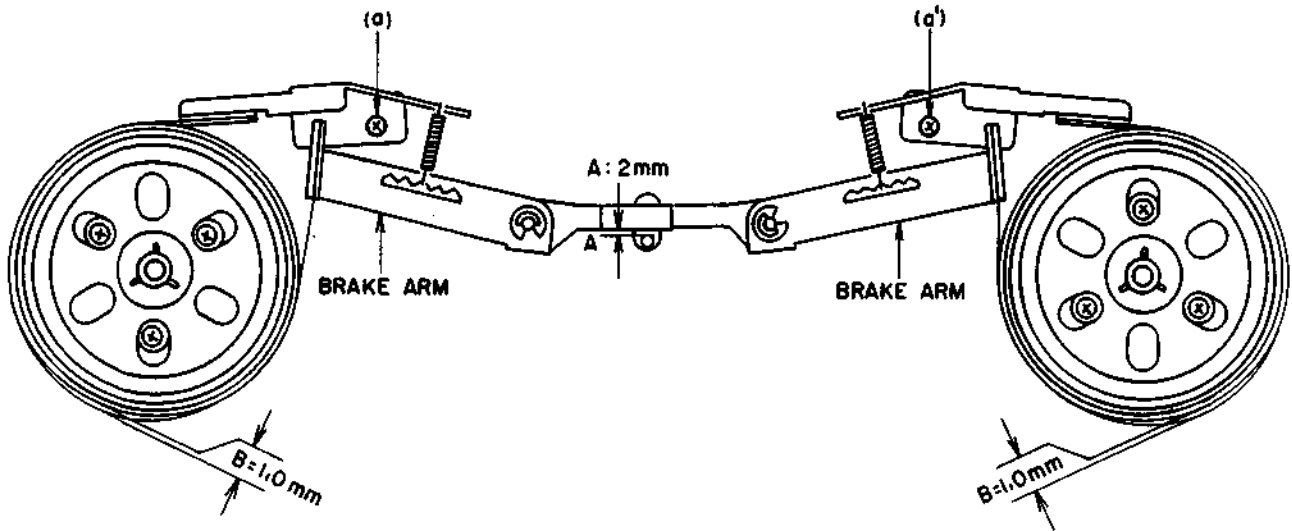

Fig. 30

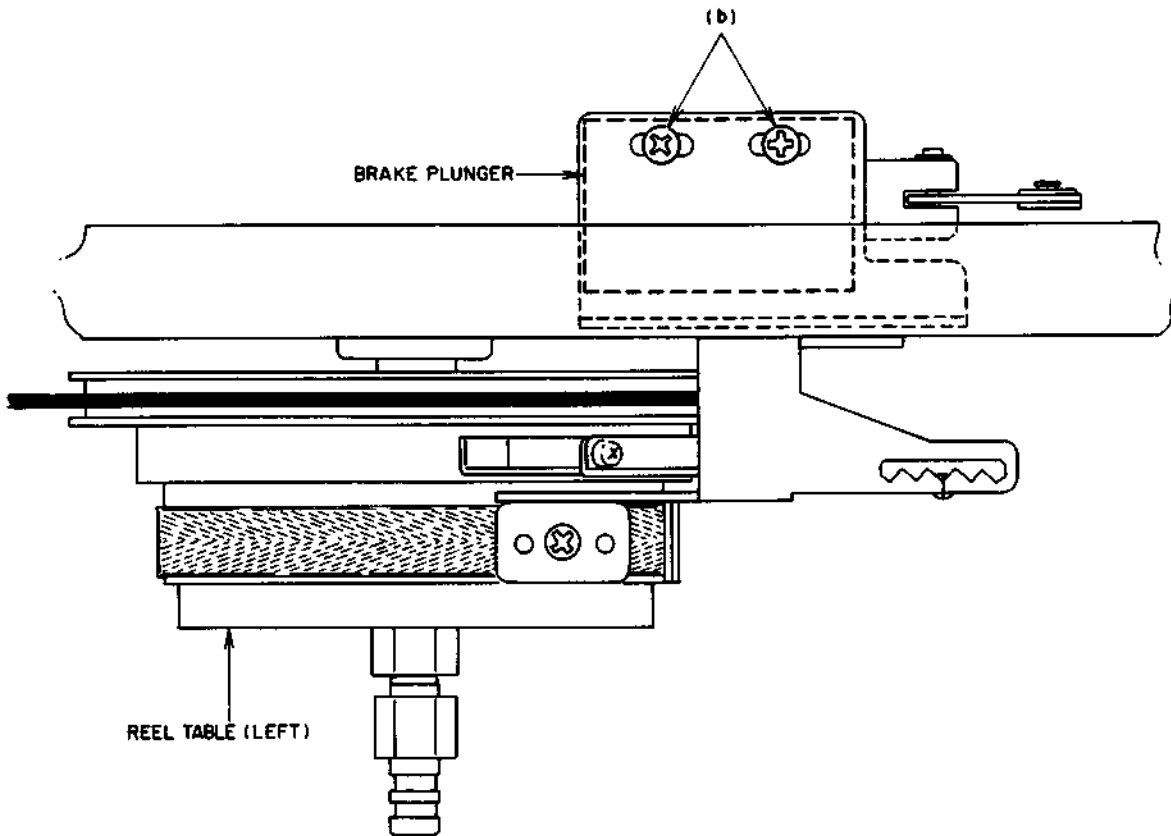

Fig. 31

### 1. BRAKE BAND POSITION ADJUSTMENT AND BRAKE TENSION ADJUSTMENT (Refer to Figs. 30, 31, 32)

- 1) In STOP Position, make adjustment with the screws (a) and (a') so that the clearance (A) will be 2.0 mm.
- 2) By working the brake plunger with fingers and adjust the brake plunger position with the screw (b) so that the clearance (B) between the brake cloth and brake band will be about 1 mm.
- 3) Work the brake plunger to check that the brake band is not slanted.
- 4) In STOP Position, change and adjust the spring position so that the brake tension of  $400 \pm 30$  g is obtained on both the brakes.  
(Use a 500 g spring gauge for a reel with 60 mm diameter of tape).

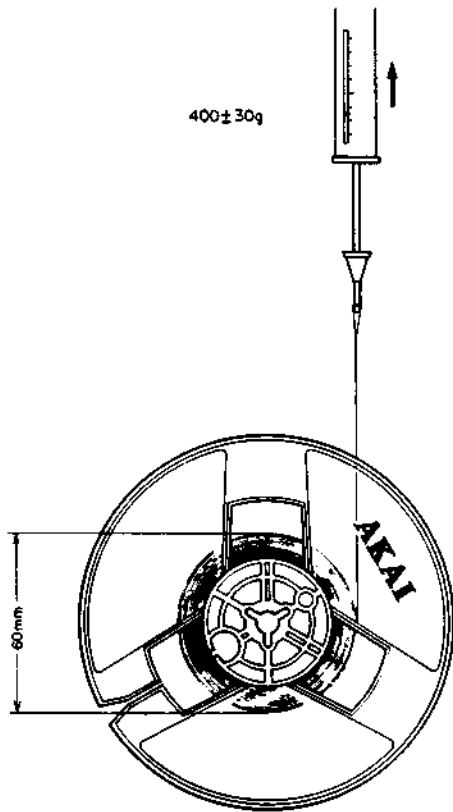

Fig. 32

## 2. PLAY PLUNGER POSITION ADJUSTMENT (Refer to Fig. 33)

With FWD PLAY mode, adjust the FWD plunger position with the screw (a) so that the clearance (A) of the slide play will be  $0.1 \pm 0.3$  mm.

Also adjust the REV plunger position in the same way in REV mode.

## 3. PINCH ROLLER PRESSURE ADJUSTMENT

With FWD PLAY mode, connect a 1 kg spring gauge to the right pinch roller cap. Pull down the pinch roller and then let it slowly move back.

Check that the spring gauge reads  $850 \text{ g} \pm 100 \text{ g}$  at the moment the pinch roller touches the capstan and starts rolling.

If it reads otherwise, replace the P spring (See Fig. 33) Also make the same adjustment about the left pinch roller in REV mode.

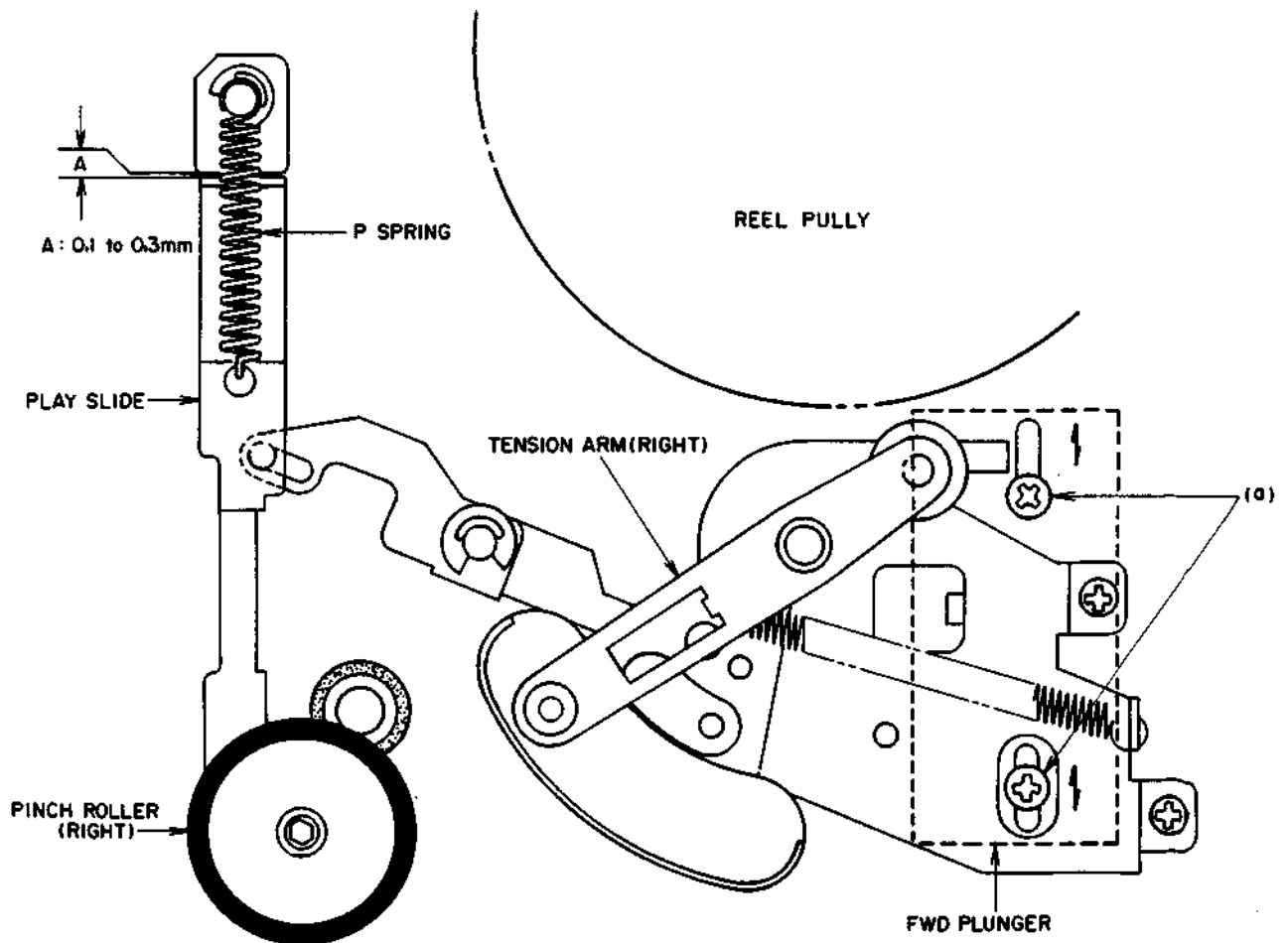

Fig. 33

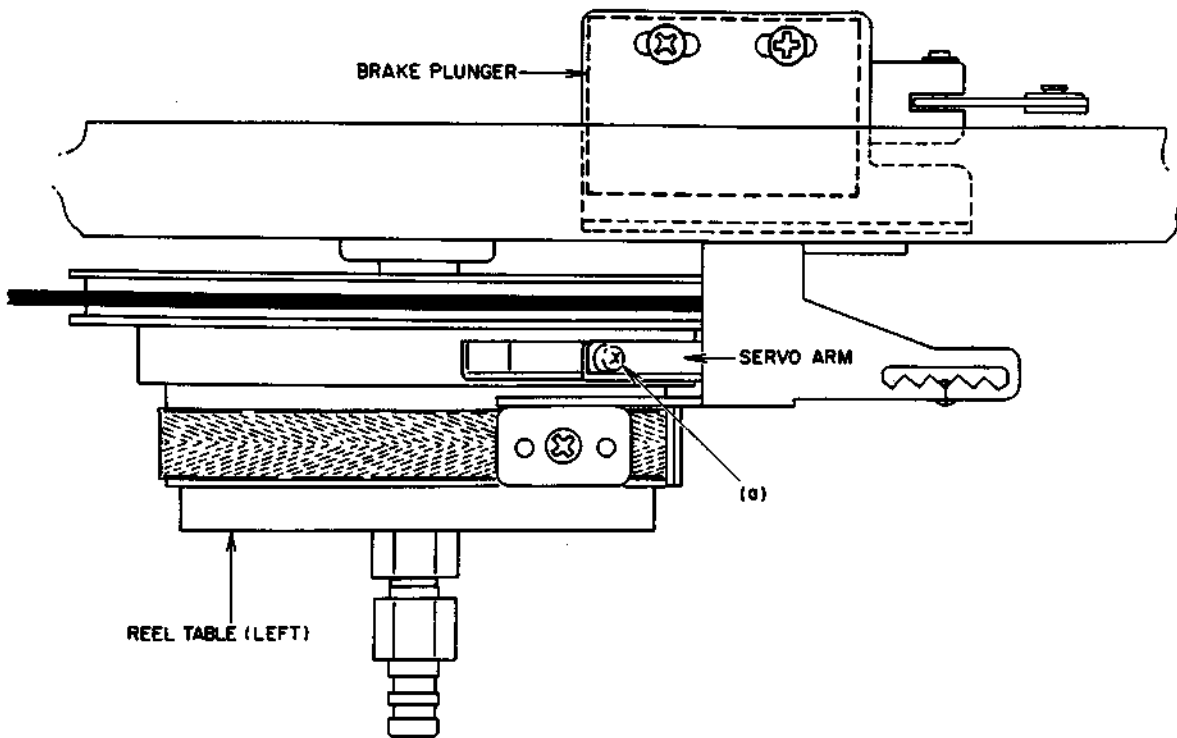

Fig. 34

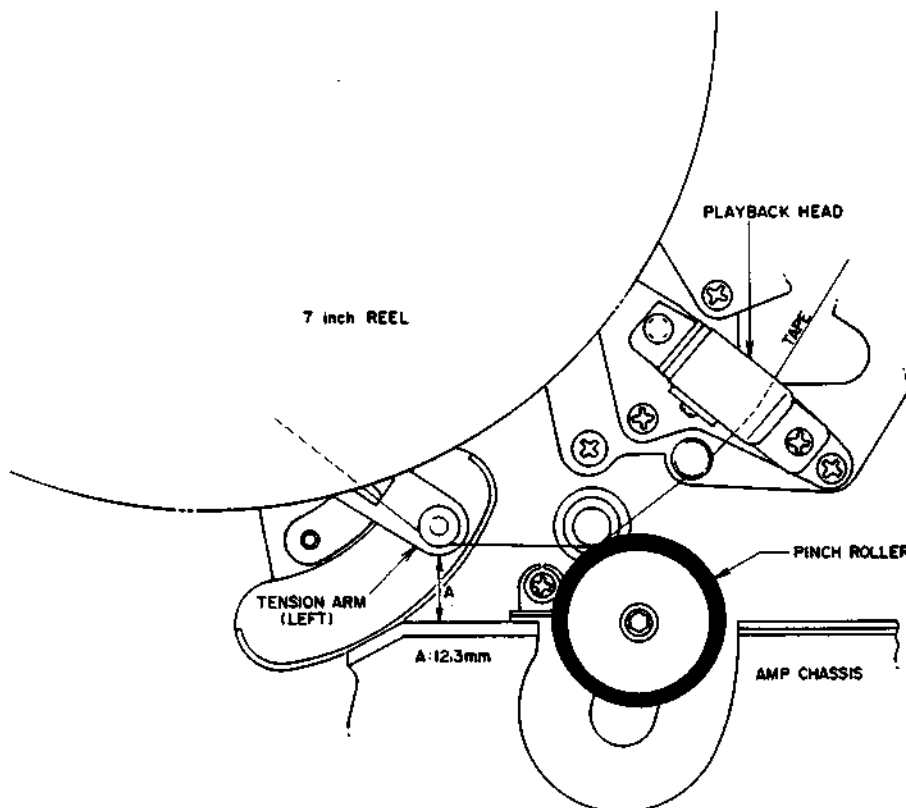

Fig. 35

#### 4. TENSION SERVO ADJUSTMENT (Refer to Figs. 34, 35)

With FWD PLAY near the center of the tape (where the tape lengths at right and left are equal), make adjustment with the screw (a) of the servo arm so that the distance (A) of 12.3 mm will be achieved

between the lower part of the tension arm tape guide at the left side and the amplifier chassis. Also make the same adjustment about the right tension arm in REV mode.

**NOTE:** Use the tape Maxell UD35-90

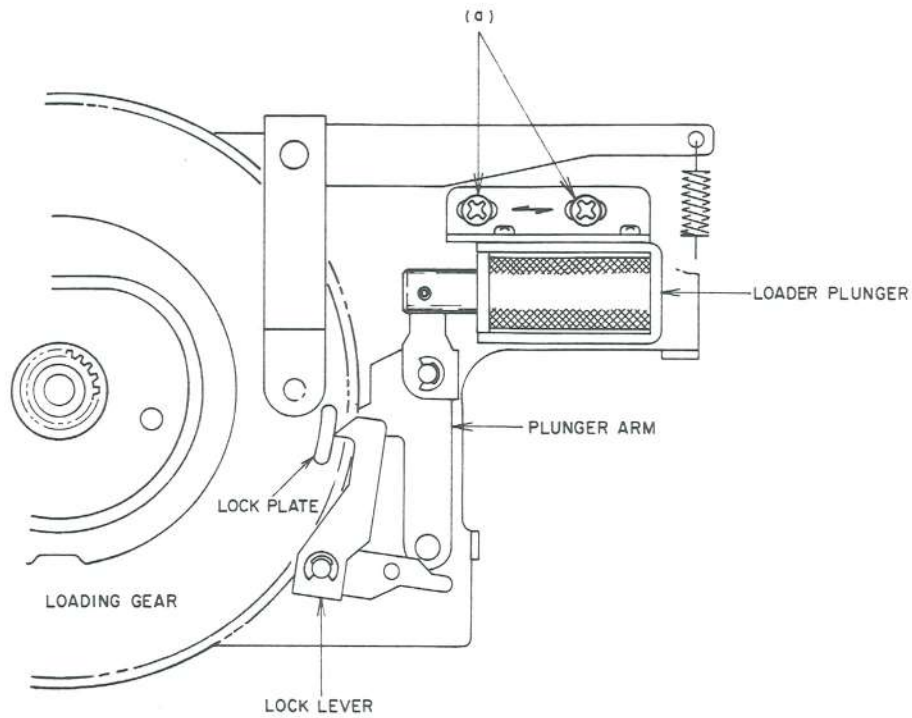

Fig. 36

REEL MOTOR (RIGHT)

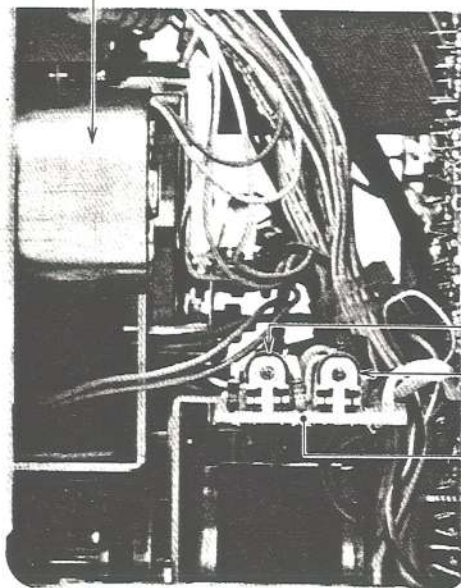

Fig. 37

**5. LOADER PLUNGER POSITION  
ADJUSTMENT (Refer to Fig. 36)**

With the loading roller up (FWD/REV PLAY mode or with the loading roller up/down button up), adjust the position of the loader plunger with the screw (a) so that the lock lever is removed from the lock plate of loading gear and put on the lock plate.

**6. TAPE SPEED ADJUSTMENT  
(Refer to Fig. 37)**

Set the Tape Speed Switch to 7-1/2 ips. and playback the 1,000 Hz, 7-1/2 Test Tape. Connect a frequency counter to VR2 10 kB until the counter reads, 1,000 Hz  $\pm$  0.8%. Next, set the Tape Speed Switch to 3-3/4 ips. and adjust VR1 20 kB until the frequency counter reads 500 Hz  $\pm$  1.0%.

# VIII. HEAD ADJUSTMENT

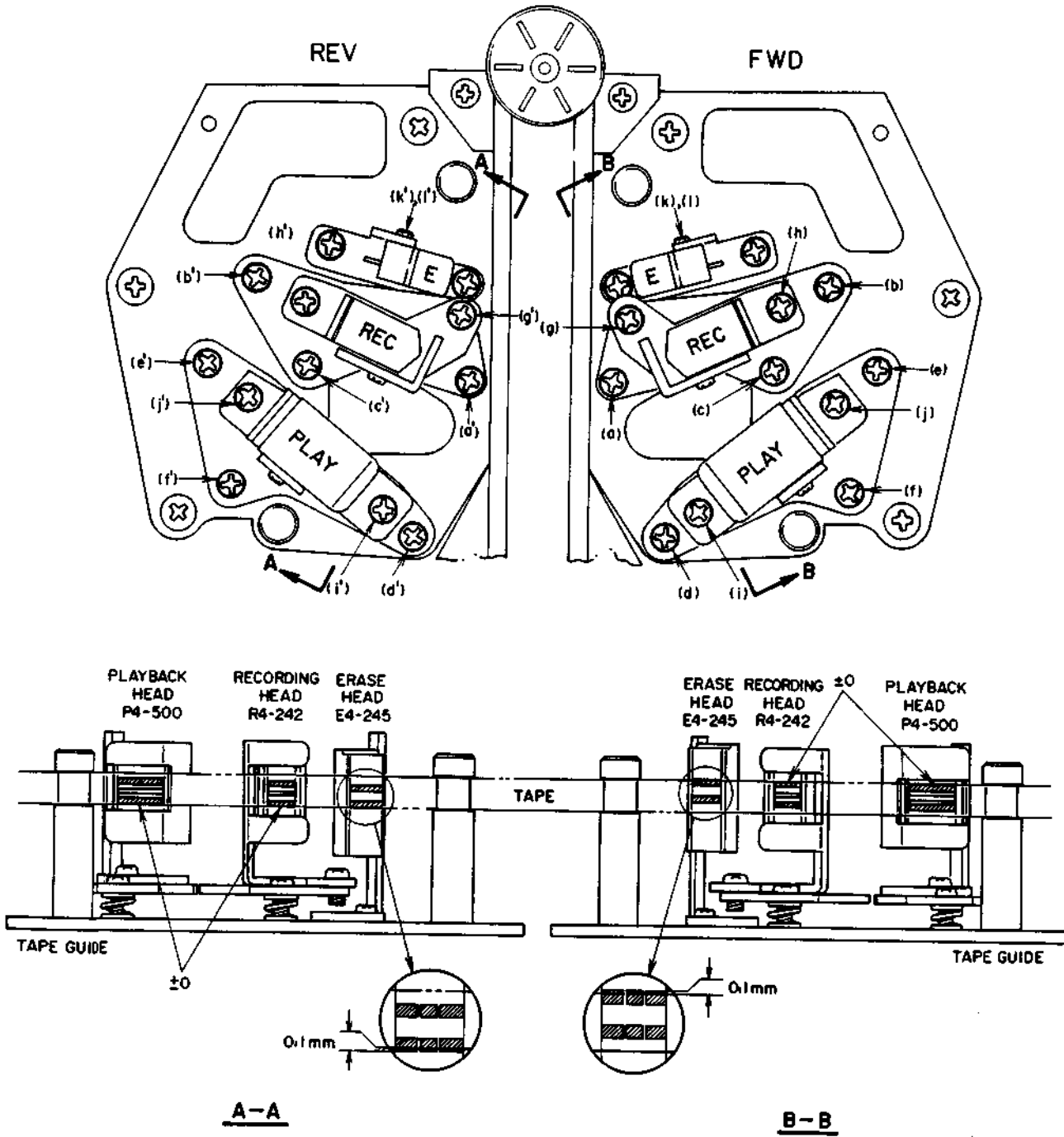

Fig. 38

Step	Adjustment Item	Test Tape Supply Signal	Mode	Adjustment Point	Remarks
1	Erase Head Height	Optional	FWD	(k) (l)	Upper edge of Left Ch. head core is 0.1 mm higher than upper edge of tape.
2	Recording Head Height	Optional	FWD	(a) (b) (c)	Upper edges of Left Ch. head core and tape are the same height. See NOTE 6.
3	Playback Head Height	Optional	FWD	(d) (e) (f)	Upper edges of Left Ch. head core and tape are the same height. See NOTE 6.
4	Playback Head Azimuth Alignment	8,000 Hz 3-3/4 ips Test Tape	FWD	(f)	Maximum output, both channels.
5	Playback Head Angle Alignment	8,000 Hz 3-3/4 ips Test Tape	FWD	(i) (j)	Adjust head gap surface so that there is no change in output level when tension is applied to the supply reel side.
6	Recording Head Azimuth Alignment	Maxell UD Tape 15,000 Hz -20 dBm	REC	(c)	Maximum output, both channels. See NOTE 7.
7	Recording Head Angle Alignment	Maxell UD Tape 15,000 Hz -20 dBm	REC	(g) (h)	Adjust head gap surface so that there is no change in output level when tension is applied to the supply reel side. See NOTE 7.

Fig. 39

- NOTES:**
- As perfect head adjustments are vital to tape deck performance, be sure that these adjustments are carried out properly.
  - Be careful not to use a magnetized driver or other magnetized tools in the vicinity of the heads.
  - Use only new tape as level variation is likely to occur when using old tape.
  - Demagnetize heads with head demagnetizer before and after head adjustment.
  - Set tape speed to 7-1/2 ips.
  - Simultaneously adjust the front and back tilts of head until uniform contact is ensured between the tape and the surface of head.
  - Set Tape Selector Switch to NORMAL Position.
  - Adjustments outlined in Fig. 39 are only for FWD side heads. However, adjustments for REV side heads are exactly the same.

# IX. AMPLIFIER ADJUSTMENT

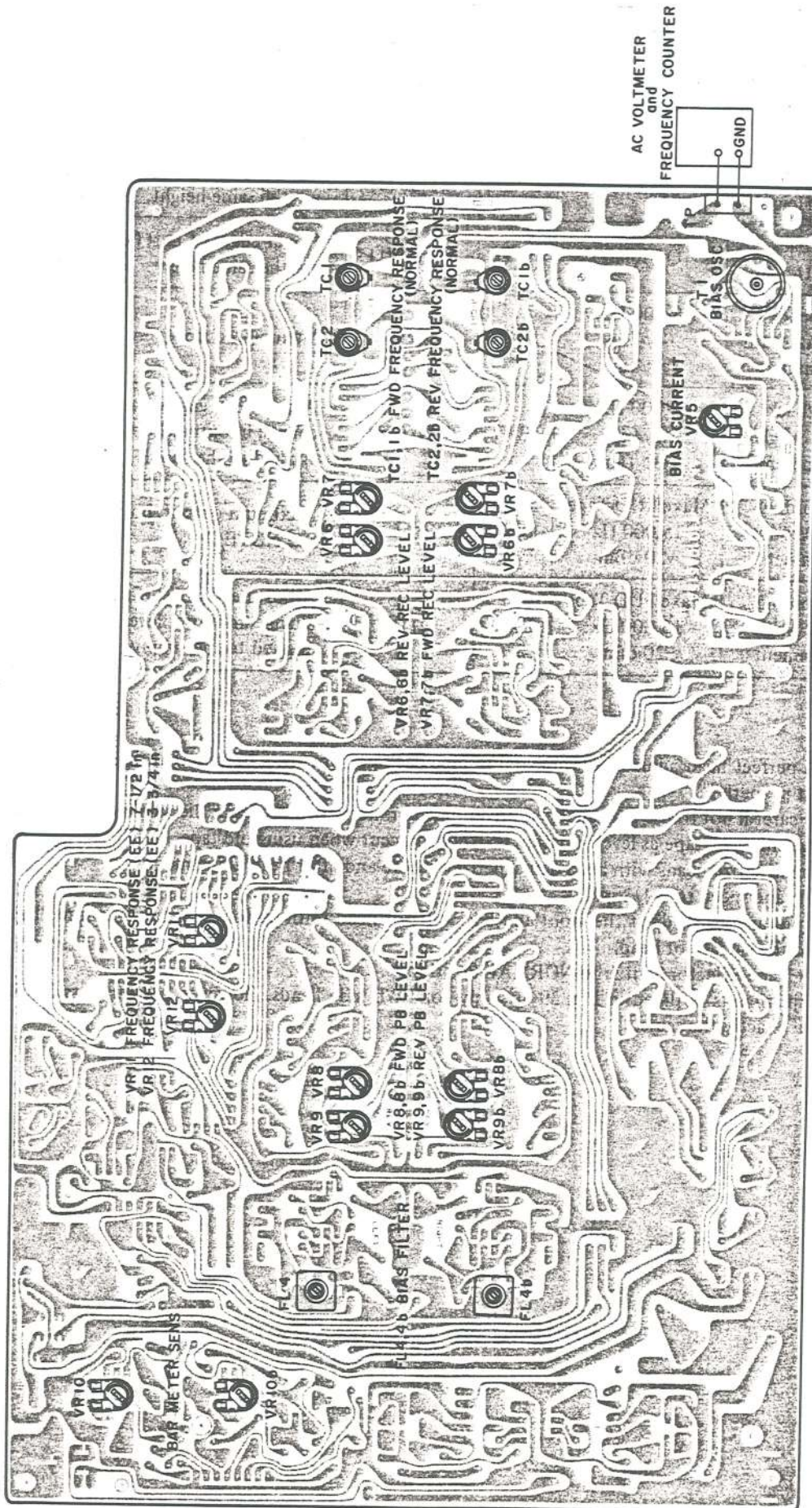

Fig. 40 Pre Amp P.C Board T1010A515A



Step	Adjustment Item	Test Tape Supply Signal	Mode	Adjustment Point	Result	Remarks
1	FWD Playback level	700 Hz 7-1/2 ips 0 VU Test Tape	FWD	VR8 50K	0 ± 0.5 dBm (0.775V)	
2	REV Playback level	700 Hz 7-1/2 ips 0 VU Test Tape	REV	VR9 50K	0 ± 0.5 dBm (0.775V)	
3	Bias OSC		REC	T1	100 ± 2 kHz	Set TAPE SELECTOR to "EE". Tape Speed 7-1/2 ips. Connect a Frequency Counter between TP and GND. Fig. 40.
4	Bias Current		REC	VR5 10K	115 mV	Set TAPE SELECTOR to "NORMAL". Tape Speed 3-3/4 ips. Connect a AC voltmeter between TP and GND. Fig. 40.
5	FWD Recording level	NORMAL Blank Tape 1,000 Hz 0 dBm Recording	FWD/ REC	VR7 20K	0 ± 0.5 dBm (0.775V)	
6	REV Recording level	NORMAL Blank Tape 1,000 Hz 0 dBm Recording	REV/ REC	VR6 20K	0 ± 0.5 dBm (0.775V)	
7	NORMAL Position FWD Frequency Response	NORMAL Blank Tape 1.5 kHz, 15 kHz -20 dBm Recording	FWD/ REC	TC1	1.5 kHz, 15 kHz flat	Tape Speed 3-3/4 ips. Recheck Recording level.
8	NORMAL Position REV Frequency Response	NORMAL Blank Tape 1.5 kHz, 15 kHz -20 dBm Recording	REV/ REC	TC2	1.5 kHz, 15 kHz flat	Tape Speed 3-3/4 ips. Recheck Recording level.
9	EE Position Frequency Response (3-3/4 ips)	EE Blank Tape 2.0 kHz, 20 kHz -20 dBm Recording	FWD, REV/ REC	VR12 20K	2.0 kHz, 20 kHz, flat	Tape Speed 3-3/4 ips. Recheck Recording level.
10	EE Position Frequency Response (7-1/2 ips)	EE Blank Tape 2.0 kHz, 20 kHz -20 dBm Recording	FWD, REV/ REC	VR11 5K	2.0 kHz, 20 kHz flat	Tape Speed 7-1/2 ips. Recheck Recording level.
11	FWD Distortion Confirmation	1,000 Hz 0 dBm Recording	FWD/ REC		NORMAL : EE : See NOTE 6.	Less than 0.5% Less than 0.5%
12	REV Distortion Confirmation	1,000 Hz 0 dBm Recording	REV/ REC		NORMAL : EE : See NOTE 6.	Less than 0.5% Less than 0.5%
13	Bar Meter Sensitivity	1,000 Hz 0 dBm from an oscillator	STOP	VR10 10K	0 VU indication	Set MONITOR Switch to "SOURCE". See NOTE 7.

Step	Adjustment Item	Test Tape Supply Signal	Mode	Adjustment Point	Result	Remarks
14	Bias Filter		REC	FL4	Less than -30 dBm	Set TAPE SELECTOR to "EE". Tape Speed 7-1/2 ips. Line Volume at MAX. See NOTE 8.

Fig. 41

- NOTES:**
1. Output Level Control should be at maximum.
  2. Except for Steps 7, 8 and 9, set Tape Speed to 7-1/2 ips.
  3. Except for Steps 3, 9 to 12 and 14, set Tape Selector Switch to NORMAL Position.
  4. Set Bias Adjustment Volume to center position.
  5. Use the following open measuring tapes:
    - NORMAL Tape: Maxell UD
    - EE Tape : Maxell XLII
    - TDK SA
  6. If it does not comply with the specifications, repeat Steps 5 to 9 and 10, and re-adjust.
  7. Light the bar meter in the ascending order with VR10 and set VR10 in position immediately when 0 dB is lit.
  8. Unless the core is moved intentionally this adjustment is not necessary.

## X. DC RESISTANCE OF VARIOUS COILS

---

Part	Designation	DC Resistance
Forward Plunger Reverse Plunger	1664TLTI	100 ohms $\pm$ 10%
Brake Plunger	1240PLTI	120 ohms $\pm$ 10%
Loader Plunger	0730TLTI	120 ohms $\pm$ 10%
Relay	G2U	400 ohms $\pm$ 10%
Relay	L24 (M)	1600 ohms $\pm$ 10%
Erase Head	E4-245	3.1 ohms
Recording Head	R4-242	5.9 ohms
Playback Head	P4-500	407 ohms $\pm$ 5%

## XI. CLASSIFICATION OF VARIOUS P.C BOARDS

---

### I. P.C BOARD TITLES AND IDENTIFICATION NUMBERS

P.C Board Title	P.C Board Number
Pre Amp P.C Board	T1010A515A
Volume P.C Board	T1010A515B
Syscon P.C Board	T1010B5250
Power Supply P.C Board	T1010B5260
Selector P.C Board	T1010C5160
Operation P.C Board	T1010C5170
Intermediate P.C Board (L)	T1010D520A
Intermediate P.C Board (R)	T1010D520B
Remocon P.C Board	T1010D5210
Counter P.C Board	T1010D5220
Lamp P.C Board	T1010D5230
Detector P.C Board	T1010D5240

## 2. COMPOSITION OF VARIOUS P.C BOARDS

### 1) PRE AMP P.C BOARD T1010A515A (2ED) and VOLUME P.C BOARD T1010A515B

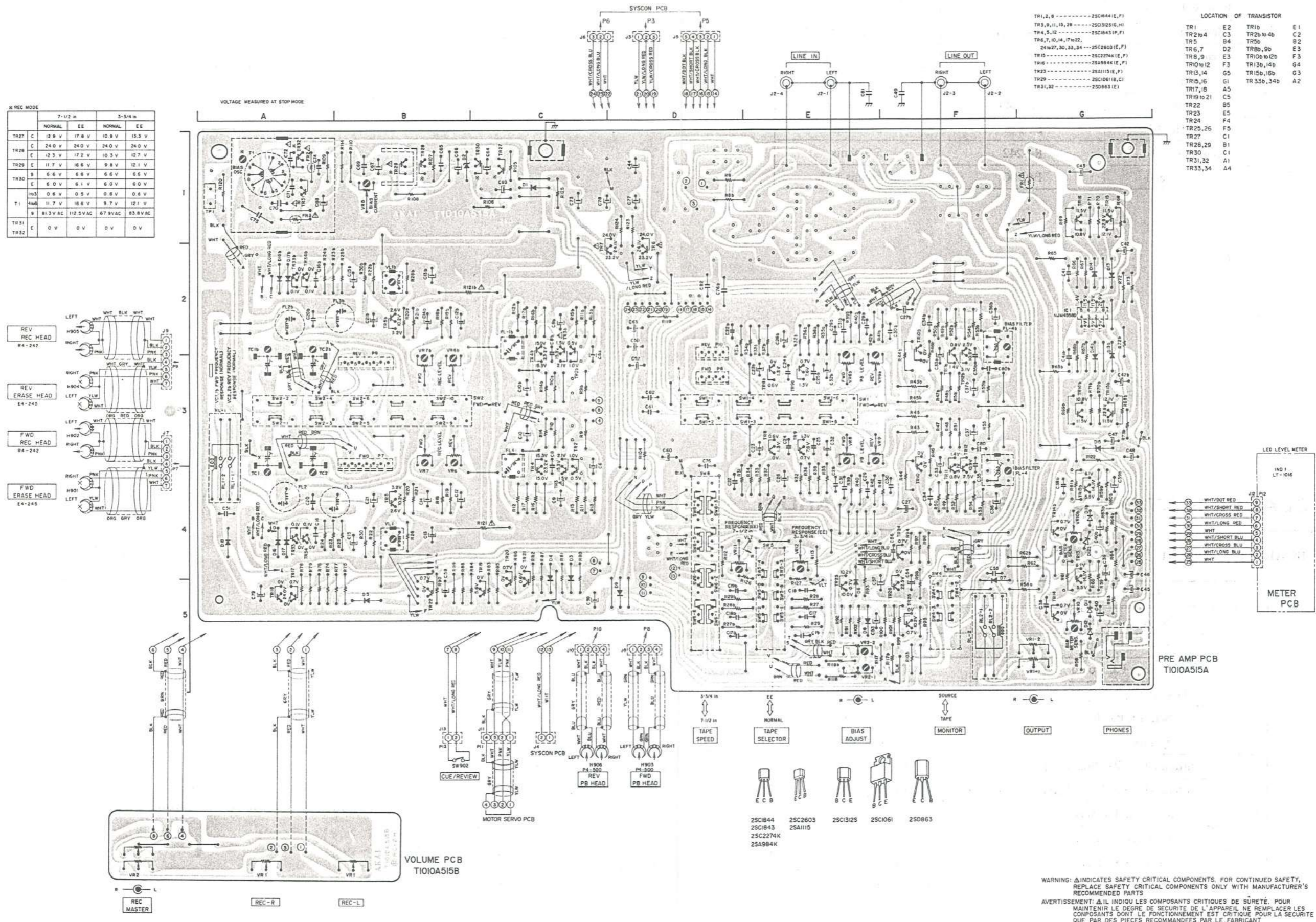

2) SYSCON P.C BOARD T1010B5250 (3ED), INTERMEDIATE P.C BOARD T1010D520A, T1010D520B, LAMP P.C BOARD T1010D5230 and DETECTOR P.C BOARD T1010D5240

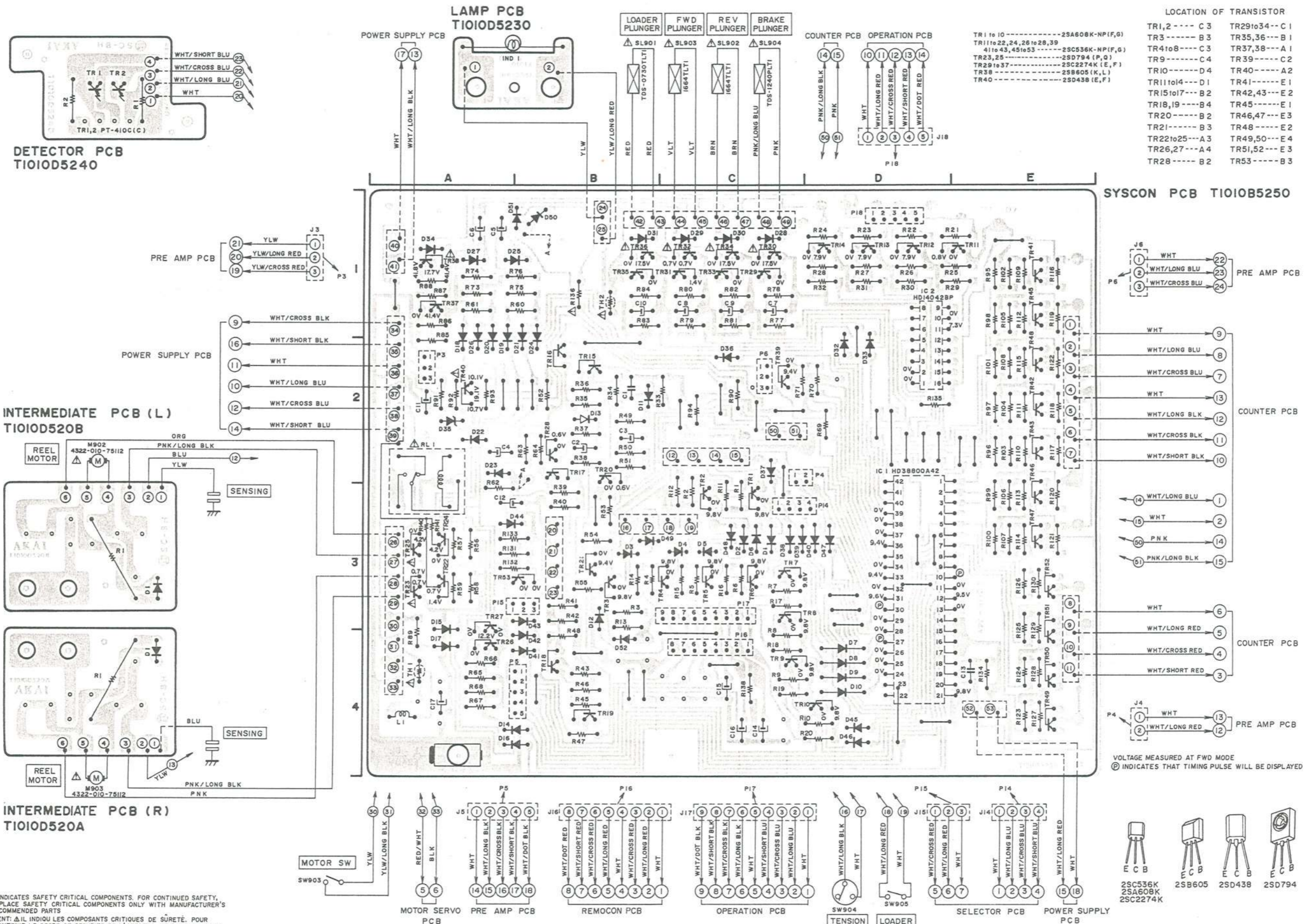

WARNING: Δ INDICATES SAFETY CRITICAL COMPONENTS. FOR CONTINUED SAFETY, REPLACE SAFETY CRITICAL COMPONENTS ONLY WITH MANUFACTURER'S RECOMMENDED PARTS.  
 AVERTISSEMENT: Δ IL INDIQUE LES COMPOSANTS CRITIQUES DE SÛRETÉ. POUR MAINTENIR LE DEGRÉ DE SÛRETÉ DE L'APPAREIL, NE REMPLACER LES COMPOSANTS DONT LE FONCTIONNEMENT EST CRITIQUE POUR LA SÛRETÉ QUE PAR DES PIÈCES RECOMMANDÉES PAR LE FABRICANT.

3) POWER SUPPLY P.C BOARD T1010B5260

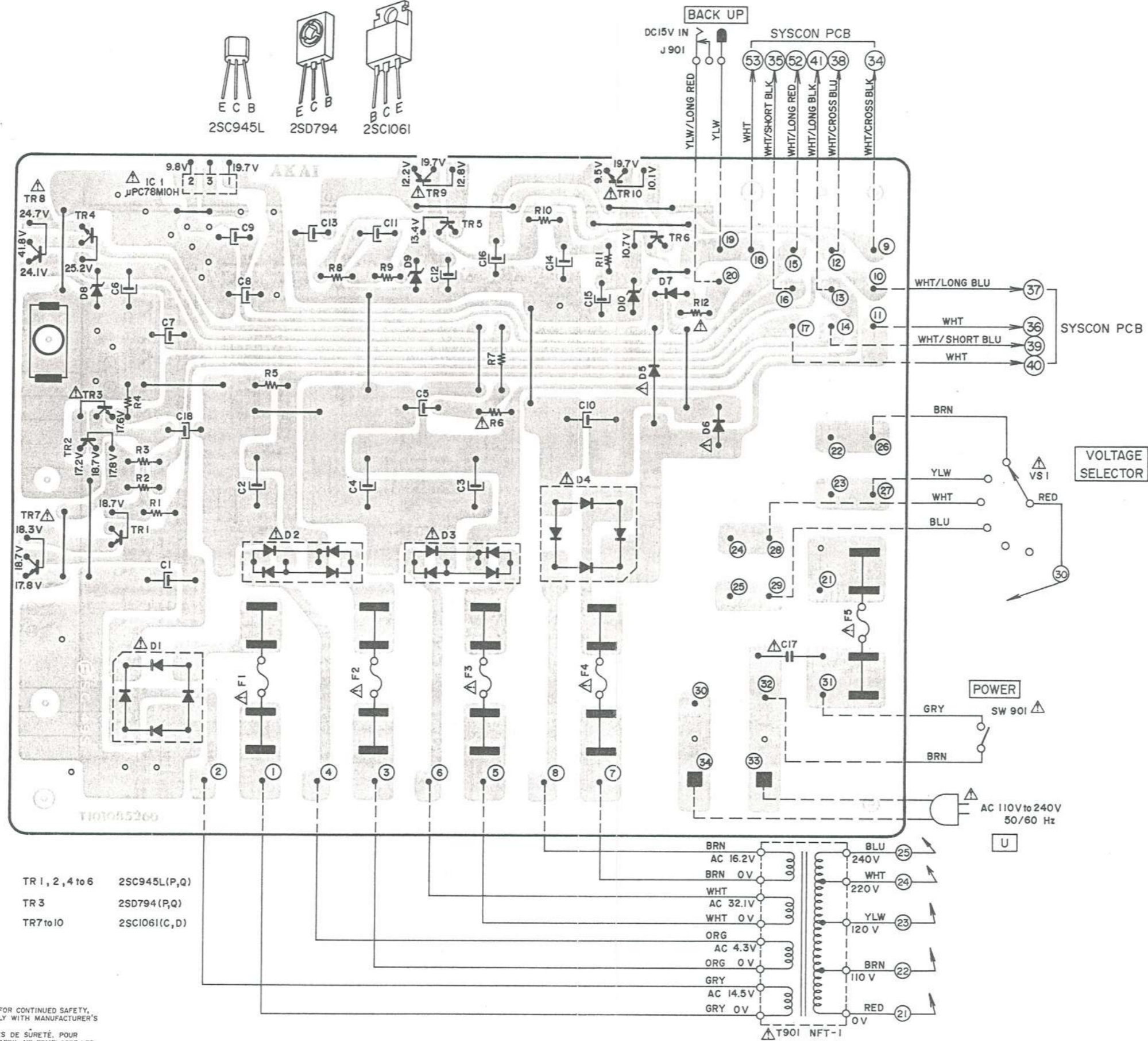
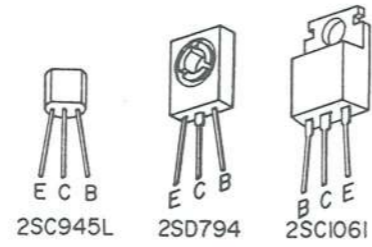

- TR 1, 2, 4 to 6 2SC945L(P,Q)
- TR 3 2SD794(P,Q)
- TR 7 to 10 2SC1061(C,D)

WARNING: Δ INDICATES SAFETY CRITICAL COMPONENTS. FOR CONTINUED SAFETY, REPLACE SAFETY CRITICAL COMPONENTS ONLY WITH MANUFACTURER'S RECOMMENDED PARTS.  
AVERTISSEMENT: Δ IL INDIQUÉ LES COMPOSANTS CRITIQUES DE SÛRETÉ. POUR MAINTENIR LE DEGRÉ DE SÛRETÉ DE L'APPAREIL, NE REMPLACER LES COMPOSANTS DONT LE FONCTIONNEMENT EST CRITIQUE POUR LA SÛRETÉ QUE PAR DES PIÈCES RECOMMANDÉES PAR LE FABRICANT.

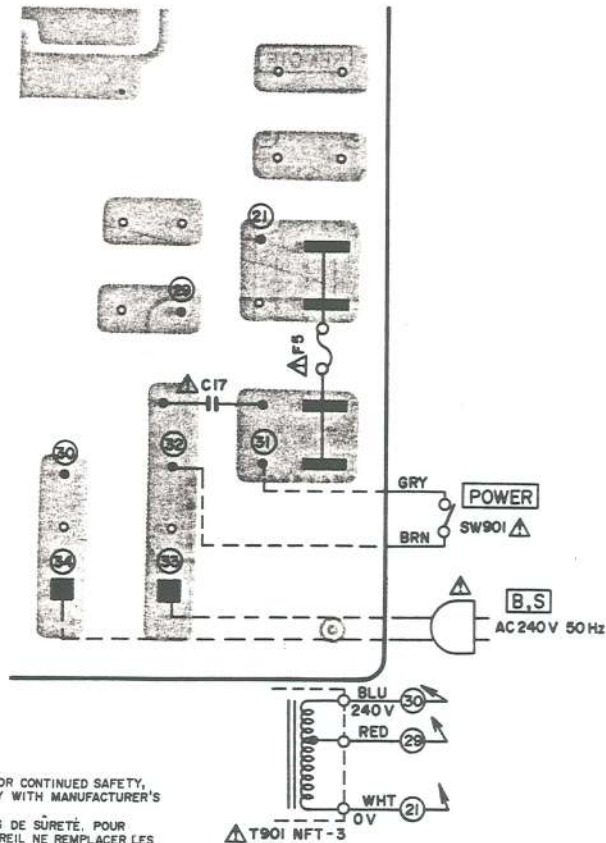
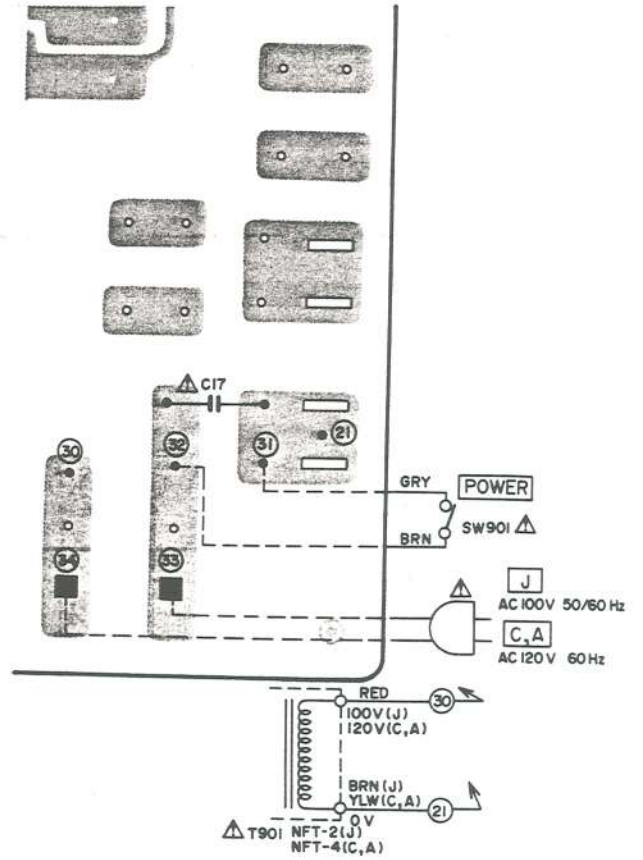
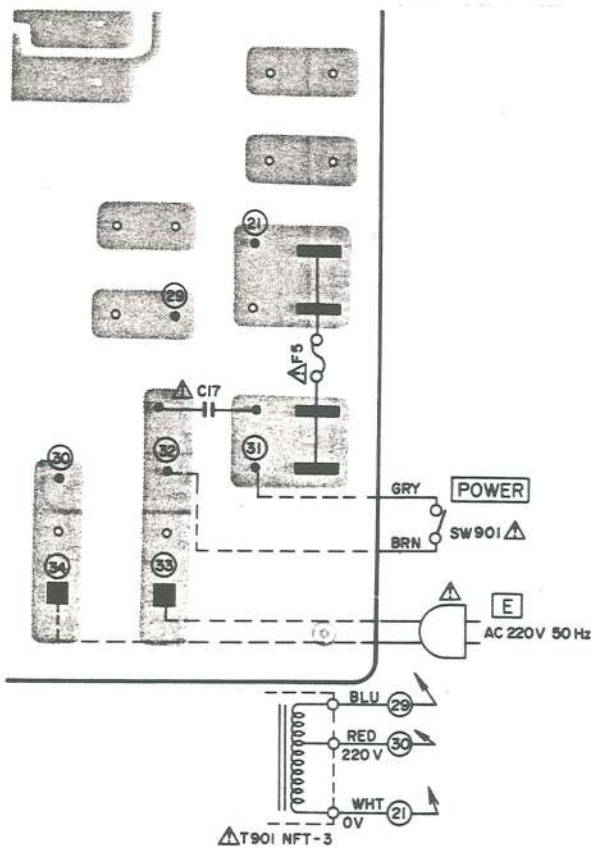

WARNING: ⚠ INDICATES SAFETY CRITICAL COMPONENTS. FOR CONTINUED SAFETY, REPLACE SAFETY CRITICAL COMPONENTS ONLY WITH MANUFACTURER'S RECOMMENDED PARTS

AVERTISSEMENT: ⚠ IL INDIQU LES COMPOSANTS CRITIQUES DE SÛRETÉ. POUR MAINTENIR LE DEGRÉ DE SÛRETÉ DE L'APPAREIL NE REMPLACER LES COMPOSANTS DONT LE FONCTIONNEMENT EST CRITIQUE POUR LA SÛRETÉ QUE PAR DES PIÈCES RECOMMANDÉES PAR LE FABRICANT

4) OPERATION P.C BOARD T1010C5170 and REMOCON P.C BOARD T1010D5210

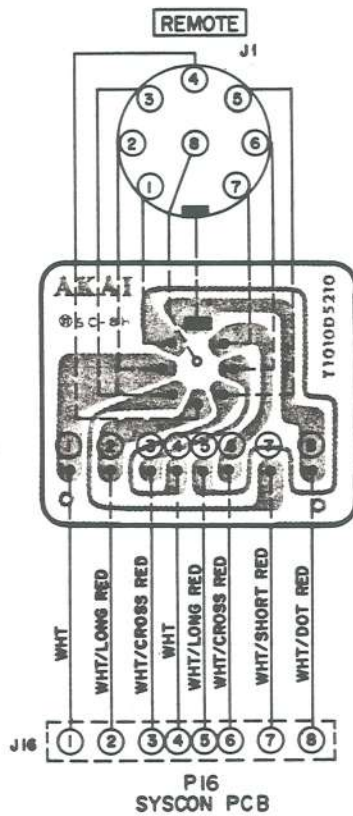
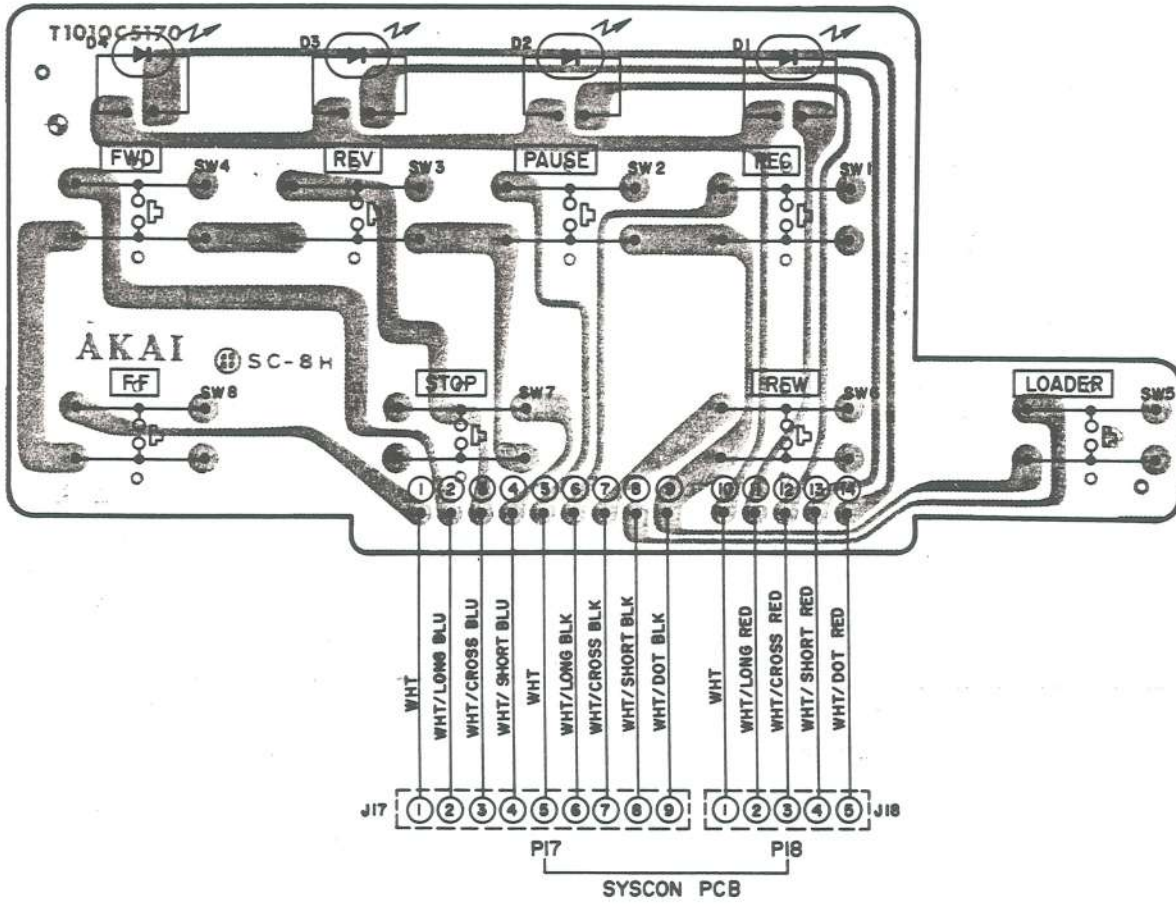



5) SELECTOR P.C BOARD T1010C5160 and COUNTER P.C BOARD T1010D5220

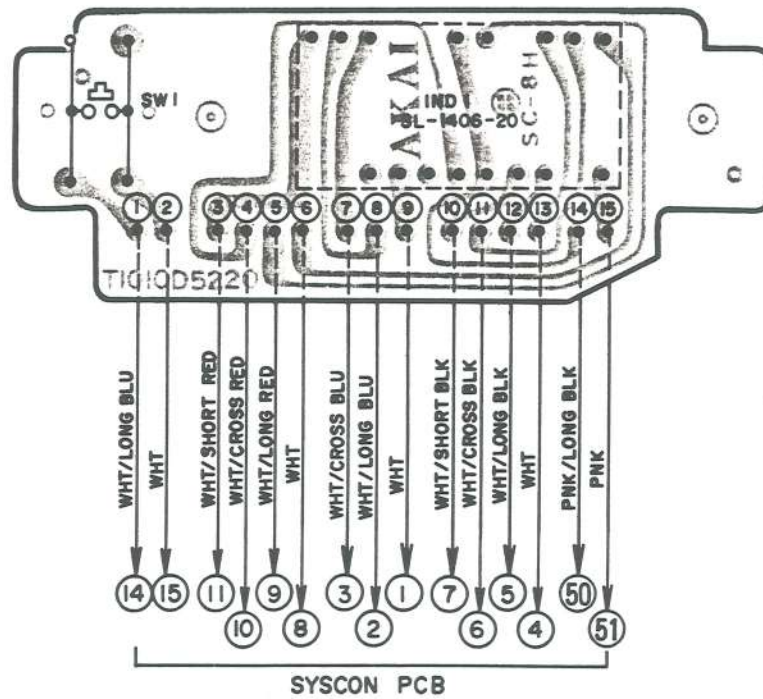
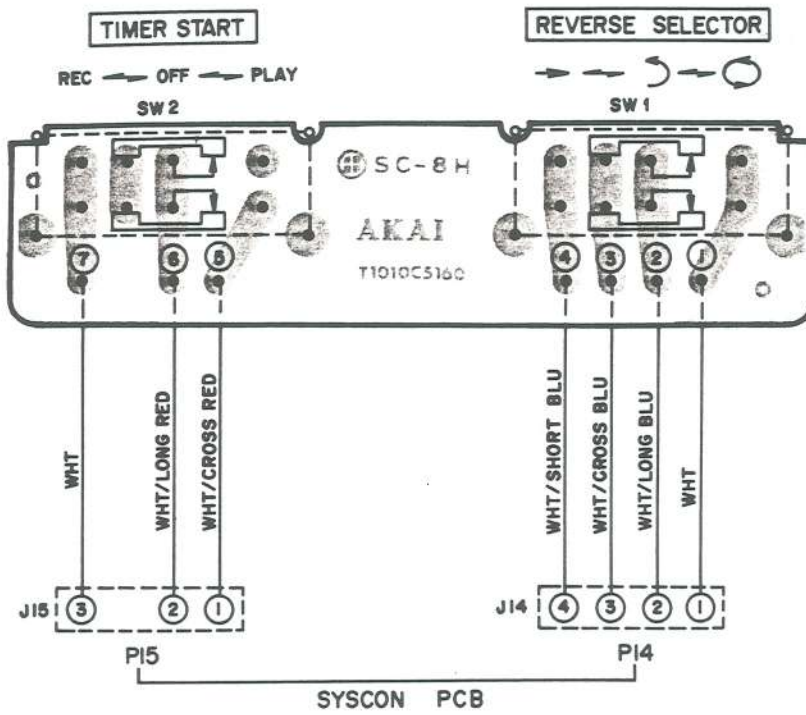

MEMO

---

---

SECTION 2

**PARTS LIST**

TABLE OF CONTENTS

1. RECOMMENDED SPARE PARTS .....	47
2. HEAD BLOCK .....	48
3. REEL TABLE BLOCK .....	50
4. ARM TENSION BLOCK .....	52
5. ROLLER BLOCK .....	53
6. MECHA BLOCK (1) .....	54
7. MECHA BLOCK (2) .....	56
8. PRE AMP P.C BOARD BLOCK .....	58
9. SYS. CON. P.C BOARD BLOCK .....	59
10. POWER SUPPLY P.C BOARD BLOCK .....	59
11. ASSEMBLY BLOCK .....	60
12. FINAL ASSEMBLY BLOCK .....	62
INDEX .....	63

Resistor and Capacitor which is not listed in this parts list, please refer to COMMON LIST FOR SERVICE PARTS.

## HOW TO USE THIS PARTS LIST

1. This parts list is compiled by various individual blocks based on assembly process.
2. When ordering parts, please describe parts number, serial number, and model number in detail.
3. How to read List

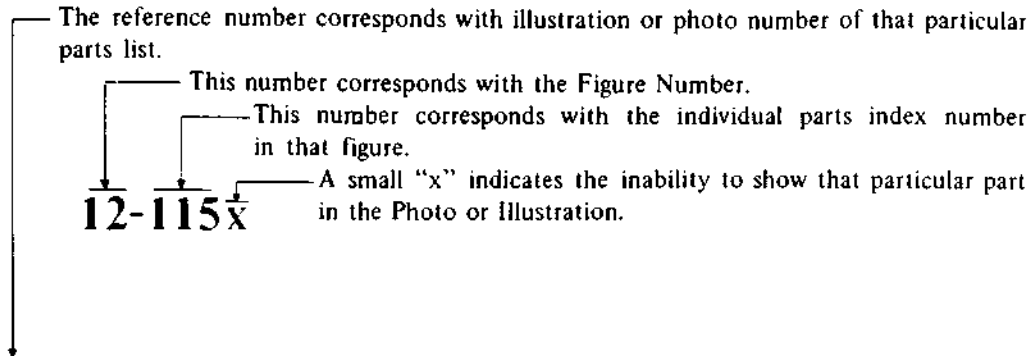

Ref. No.	Parts No.	Description
<b>FLYWHEEL BLOCK #13</b>		
12-115x	800425	Flywheel Block Assy. Comp.
12-116	244506	Flywheel Only
12-117x	244754	Felt. Flywheel
12-118	251324	Main Metal Case
12-119	253080	Main Metal

4. The symbol numbers shown on the P.C. Board list can be matched with the Composite Views of Components of the Schematic Diagram or Service Manual.
5. Please utilize separate "Common List for Service Parts" for Resistor Parts orders.
6. The shape of the parts and parts name, etc. can be confirmed by comparing them with the parts shown on the Electrical Parts Table of P.C. Board.
7. Both the kind of part and installation position can be determined by the Parts Number. To determine where a parts number is listed, utilize Parts Index at end of Parts List.  
It is necessary first of all to find the Parts Number. This can be accomplished by using the Reference Number listed at right of parts number in the Parts Index. (meaning of ref. no. outlined in Item 3 above).
8. Utilize separate "Price List for Parts" to determine unit price. The most simple method of finding parts Price is to utilize the reference number.

- CAUTION:**
1. When placing an order for parts, be sure to list the parts no. model no., and description. There are instances in which if any of this information is omitted, parts cannot be shipped or the wrong parts will be delivered.
  2. Please be careful not to make a mistake in the parts no. If the parts no. is in error, a part different from the one ordered may be delivered.
  3. Because parts number and parts unit supply in the Preliminary Service Manual (Basic Parts List) may be partially changed, please use this parts list for all future reference.

**WARNING:** INDICATES SAFETY CRITICAL COMPONENTS. FOR CONTINUED SAFETY, REPLACE SAFETY CRITICAL COMPONENTS ONLY WITH MANUFACTURER'S RECOMMENDED PARTS.

**AVERTISSEMENT:** IL INDIQU LES COMPOSANTS CRITIQUES DE SURETE. POUR MAINTENIR LE DEGRE DE SECURITE DE L'APPAREIL NE REMPLACER LES COMPOSANTS DONT LE FONCTIONNEMENT EST CRITIQUE POUR LA SECURITE QUE PAR DES PIECES RECOMMANDEES PAR LE FABRICANT.

## 1. RECOMMENDED SPARE PARTS

Because, if the parts listed below are on hand, almost any repair can be accomplished, we suggest that you stock these Recommended Spare Parts Items.

REF. NO.	PARTS NO.	DESCRIPTION	REF. NO.	PARTS NO.	DESCRIPTION
1-1	BMT1010A130A	CAPSTAN MOTOR BLK GX-77	1-65	ES283072	SW SLIDE SSC22LP 2-02-02N
1-2	BM331256	MOTOR 4322-010-75112	1-66	ES315362	SW TACT AKC8S
1-3	BT331218	Δ TRANS POWER NFT-1 (U)	1-67	ET324539	TR PHOTO PT-410C C
1-4	BT331219	Δ TRANS POWER NFT-2 (J)	1-68	ET200558	TR 2SA1115 E,F
1-5	BT331220	Δ TRANS POWER NFT-3 (E,B,S,V)	1-69	ET331223	TR 2SA608KWBNP F,G SNP
1-6	BT331221	Δ TRANS POWER NFT-4 (C,A)	1-70	ET324134	TR 2SA984K E,F
1-7	BZT1010A240A	GEAR LOADING BLK GX-77	1-71	ET666415	TR 2SB605 K,L
1-8	BZT1010A050A	HOLDER LOADING ARM BLK GX-77	1-72	ET375603	TR 2SC1061B,C
1-9	ED308952	D GERMA V 1K34A-LR F07	1-73	ET317919	TR 2SC1061 C,D
1-10	ED331227	D GERMA V 1K34A-UF SNP	1-74	ET603257	TR 2SC1312S G,H
1-11	ED330996	D LED GL-5HY5 YLW	1-75	ET331279	TR 2SC1843 P,F SNP
1-12	ED330997	D LED GL-5PR5 RED	1-76	ET308954	TR 2SC1844 E,F
1-13	ED330995	D LED SLP-260C GRN	1-77	ET309353	TR 2SC2274 E,F
1-14	ED313566	D SILICON GP-25G 400/2.5A	1-78	ET331225	TR 2SC2274K-WB E,F SNP
1-15	ED301911	D SILICON H DS448	1-79	ET200505	TR 2SC2603 E,F
1-16	ED316143	D SILICON H 1S2473HS F10	1-80	ET331224	TR 2SC536KWBNP F,G SNP
1-17	ED330987	D SILICON RB152 200/1.5A	1-81	ET639437	TR 2SC945L Q,P
1-18	ED560913	D SILICON V 1S2473VE	1-82	ET219857	TR 2SD438 E,F
1-19	ED306109	D SILICON W03B 100/1.0A	1-83	ET307349	TR 2SD794 P,Q
1-20	ED330622	D SILICON 1SR35-100VL 100/1.0A	1-84	ET331196	TR 2SD863 E
1-21	ED319463	D SILICON 4B4B41 100/4.0A	1-85	EV336853	R S-FIX H KVSF807V 3P 103
1-22	ED330989	D ZENER H HZ11 B2	1-86	EV336849	R S-FIX H KVSF807V 3P 203
1-23	ED315759	D ZENER H HZ16 1	1-87	EV336843	R S-FIX H KVSF807V 3P 303
1-24	ED329051	D ZENER H HZ24 3	1-88	EV341225	R S-FIX H KVSF807V 3P 503
1-25	ED331198	D ZENER H HZ3 A1	1-89	EV331199	VR ROTARY 16P10x1E 15A503
1-26	ED331197	D ZENER H HZ6 C1	1-90	EV331201	VR ROTARY 16P20x2F A503
1-27	ED324082	IND FL SL-1406-20 CHARACTER	1-91	EV331202	VR ROTARY 16P20x2G 3B103
1-28	ED331263	IND LE LT-1016 GRAPH	1-92	EV331285	VR ROTARY 16P20x2H B502
1-29	EF258344	Δ FUSE SEMKO T 250V 0.80A (F3) (U,E,B,S,V)	1-93	HEH1305A010A	HEAD E E4-245 O
1-30	EF602550	Δ FUSE SEMKO T 250V 1.25A (F4) (U,E,B,S,V)	1-94	HPH1005A010A	HEAD PB P4-500 O
1-31	EF602550	Δ FUSE SEMKO T 250V 1.25A (F5) (U,E,B,S,V)	1-95	HRH1103A010A	HEAD REC R4-242 O
1-32	EF601964	Δ FUSE SEMKO T 250V 1.60A (F2) (U,E,B,S,V)	1-96	MB331350	BELT CAPSTAN
1-33	EF601301	Δ FUSE SEMKO T 250V 2A (F1) (U,E,B,S,V)	1-97	MB331351	BELT REEL
1-34	EF309388	Δ FUSE TSC A 250V 0.80A (F3)(J)	1-98	MI331310	FLYWHEEL (A)
1-35	EF306949	Δ FUSE TSC A 250V 1.25A (F4)(J)	1-99	MI331311	FLYWHEEL (B)
1-36	EF311839	Δ FUSE TSC A 250V 1.6A (F2) (J)	1-100	MP331347	ROLLER PINCH
1-37	EF306951	Δ FUSE TSC A 250V 2.5A (F1) (J)	1-101	MZ331397	GEAR LOADING (B)
1-38	EF309391	Δ FUSE TSC 125V 0.08A (F3)(C,A)	1-102	SZ331312	GEAR CAPSTAN
1-39	EF309392	Δ FUSE TSC 125V 1.25A (F4)(C,A)	1-103	SZ331394	GEAR FIX
1-40	EF308847	Δ FUSE TSC 125V 1.60A (F2)(C,A)	1-104	SZ338391	GEAR SET
1-41	EF306956	Δ FUSE TSC 125V 2.5A (F1)(C,A)			
1-42	EI331573	IC HD14042BP			
1-43	EI331222	IC HD38800A42			
1-44	EI213390	IC NJM4558D			
1-45	EI331249	IC μPC78M10H			
1-46	EL324540	PL H LEAD 12V 55MA			
1-47	EP331258	SOLENOID 0730TLT1			
1-48	EP331257	SOLENOID 1240PLT1			
1-49	EP331254	SOLENOID 1664TLT1 (TDS-16C-01)			
1-50	EP331253	SOLENOID 1664TLT1 (TDS-16C-02)			
1-51	ER331188	R FUSE ERD2FC F10 1/4W 8R2J			
1-52	ER319510	R FUSE FR25SJ 1/4W 560J			
1-53	ES283151	SW LEAF BSW-31NL 01-1 NO			
1-54	ES331259	SW LEAF BSW-810 01-1 NO			
1-55	ES319448	SW LEVER 00420461 2-04-02N			
1-56	ES331203	SW LEVER 00620387 2-06-02S			
1-57	ES331205	SW LEVER 00820190 2-08-02S			
1-58	ES331575	SW MICRO D2MV-01-1C1 CU			
1-59	ES330422	SW PUSH SDL1P 01-1 E (U,E,B,S,V)			
1-60	ES330420	SW PUSH SDL1P 01-1 J (J)			
1-61	ES330421	SW PUSH SDL1P 01-1 UC (C,A)			
1-62	ES331204	SW SLIDE CL208E 2-08-02W			
1-63	ES301435	SW SLIDE CL210E 2-10-02S			
1-64	ES331260	SW SLIDE SSB423 2-02-03N			

When ordering parts, please quote Parts Number, Description and Model Number.

# HEAD BLOCK

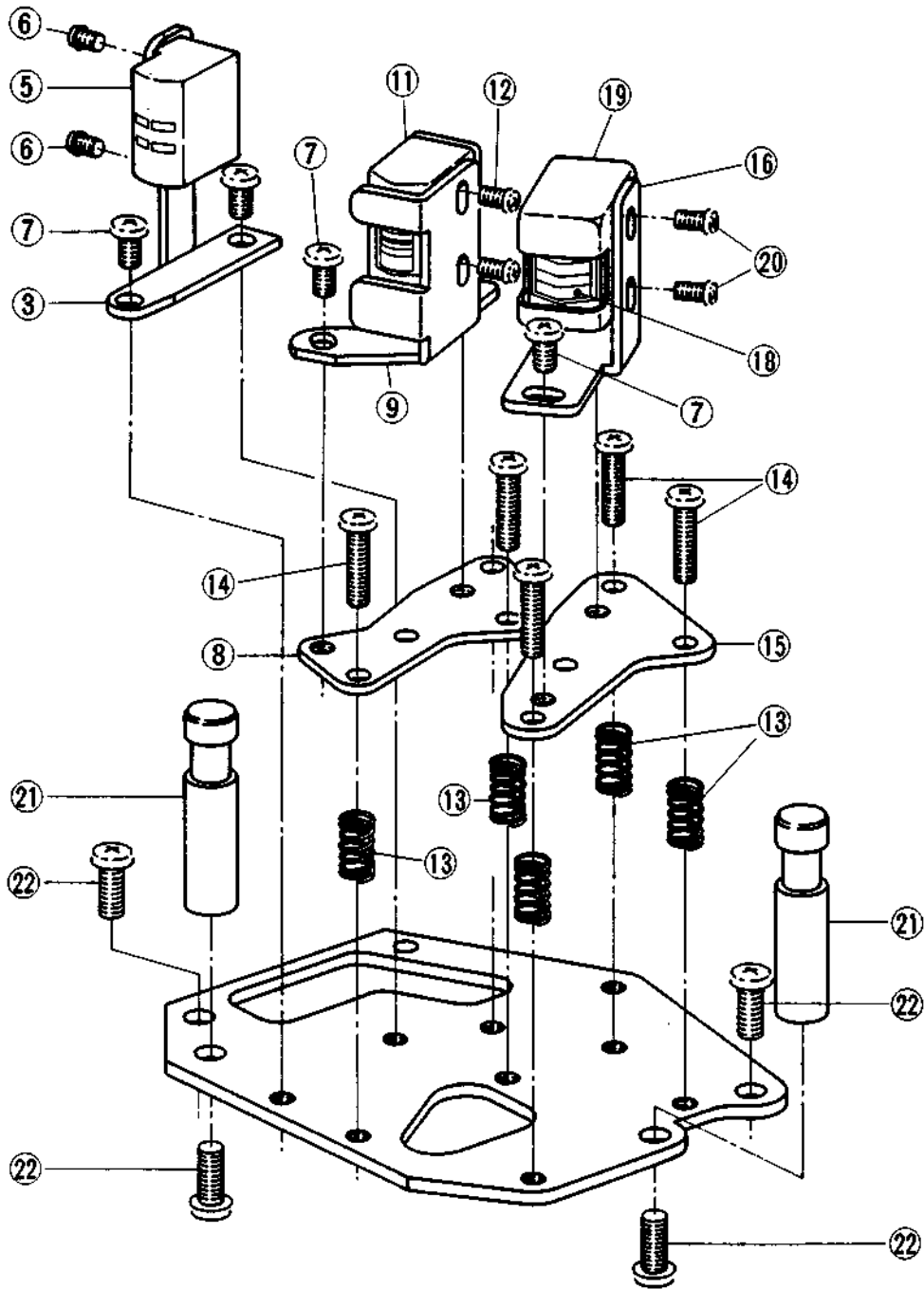

---

## 2. HEAD BLOCK

REF. NO.	PARTS NO.	DESCRIPTION
2-1	BHT1010A370A	ANGLE HEAD (R) BLK GX-77
2-2	BHT1010A360A	ANGLE HEAD (L) BLK GX-77
2-3	HZ331172	CHASSIS HEAD
2-4x	HZ331171A	ANGLE E HEAD (L)
2-5	HEH1305A010A	HEAD E E4-245 O
2-6	ZS477876	PAN20x03STL CMT
2-7	ZS323728	BID30x05STL CMT
2-8	HZ331147	HOLDER REC HEAD ANGLE
2-9	HZ331148B	ANGLE REC HEAD (R)
2-10x	HZ331148A	ANGLE REC HEAD (L)
2-11	HRH1103A010A	HEAD REC R4-242 O
2-12	ZS460440	PAN20x04STL CMT
2-13	ZG206144	ANGLE ADJUST SPRING
2-14	ZS419670	PAN30x12STL CMT
2-15	HZ331149	HOLDER PB HEAD ANGLE
2-16	HZ331150B	ANGLE PB HEAD (R)
2-17x	HZ331150A	ANGLE PB HEAD (L)
2-18	HPH1005A010A	HEAD PB P4-500 O
2-19	HZ330925	HEAD SHIELD
2-20	ZS608095	PAN20x05STL CMT
2-21	HZ331151	GUIDE TAPE
2-22	ZS417150	PAN40x06STL CMT

REEL TABLE BLOCK

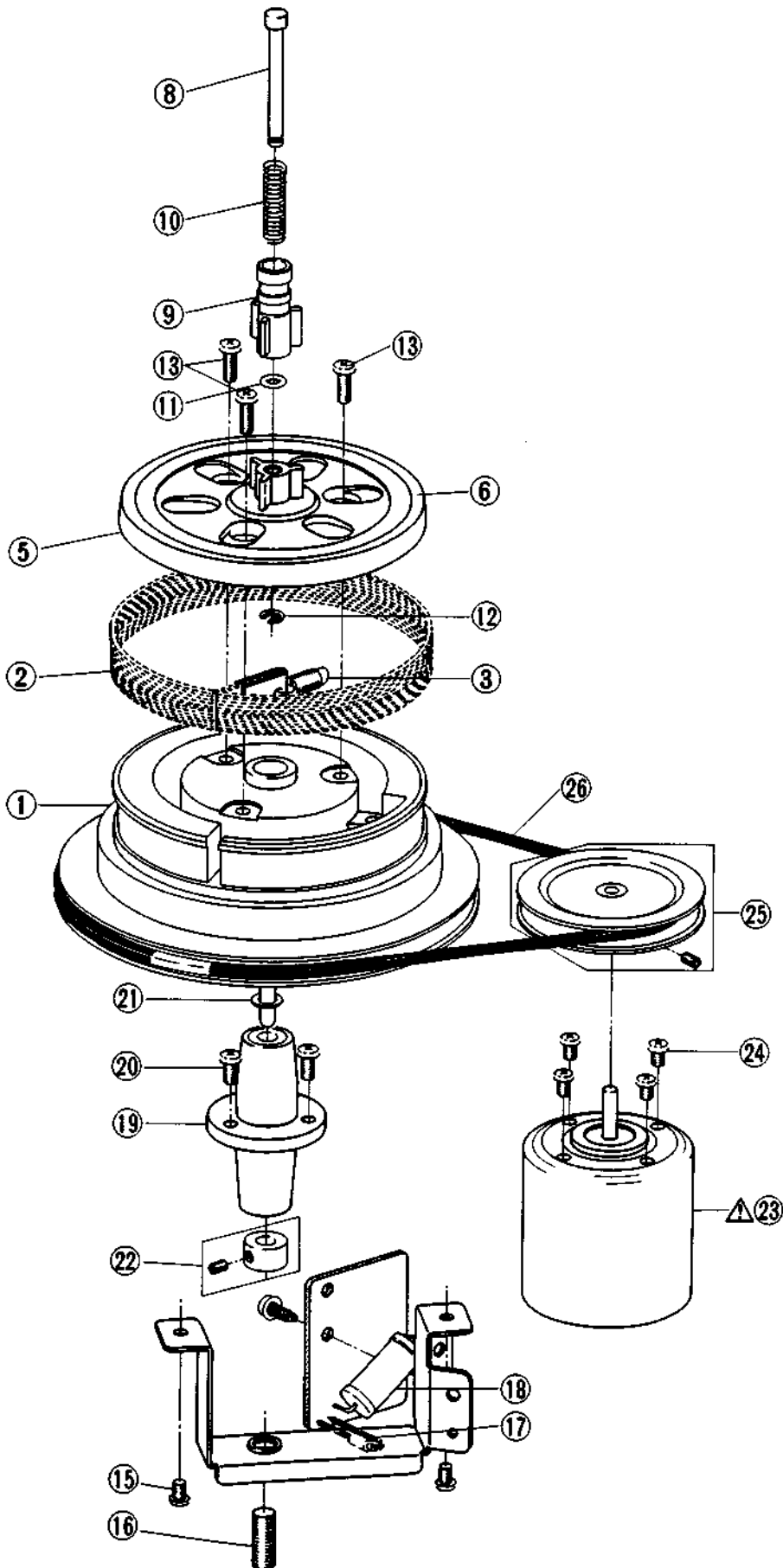



---

### 3. REEL TABLE BLOCK

REF. NO.	PARTS NO.	DESCRIPTION
		<b>PULLEY REEL BLOCK</b>
3-1	MR331432	PULLEY REEL
		<b>BRAKE CLOTH ASSY</b>
3-2	MTT1003A340A	BRAKE CLOTH ASSY GX-215D
3-3	ZG317496	FELT TENSION SPRING
3-4x	ZS455207	T2BR30x05STL CMT
		<b>REEL TABLE BLOCK</b>
3-5	MTB603571	REEL TABLE W/RUBBER (B) PART
3-6	MT300426	REEL TABLE RUBBER
3-7x	MTB604269	REEL TABLE W/RUBBER (C) PART (BL)
3-8	MS342000	REEL SHAFT
3-9	MT458943	REEL RETAINER
3-10	ZG255633	REEL SPRING
3-11	MT516565	'O' RING 2.8x1.9
3-12	ZW270088	RING E 190SUP CMT
3-13	ZS336628	BT BID30x14STL N13
3-14x	ZS336629	BT BID30x14STL BNI (BL)
		<b>HOLDER REEL BLOCK</b>
3-15	ZS331111	T2BR30x08STL CMT TWB
3-16	ZS302318	HOLD SCREW
		<b>PC RELAY BLOCK</b>
3-17	ED306109	D SILICON W03B 100/1.0A (D1)
3-18	ER280710	R OMF H FS 3W 101J (R1)
		<b>ASSEMBLY BLOCK</b>
3-19	MZ331362	HOLDER REEL SHAFT
3-20	ZS379350	PAN30x06STL CMT
3-21	ZW259738	PW41x070x025PSL
3-22	MT331326	RING REEL
3-23	BM331256	Δ MOTOR 4322-010-75112
3-24	ZS417216	PAN30x04STL CMT
3-25	MR331328	PULLEY REEL MOTOR
3-26	MB331351	BELT REEL

## ARM TENSION BLOCK

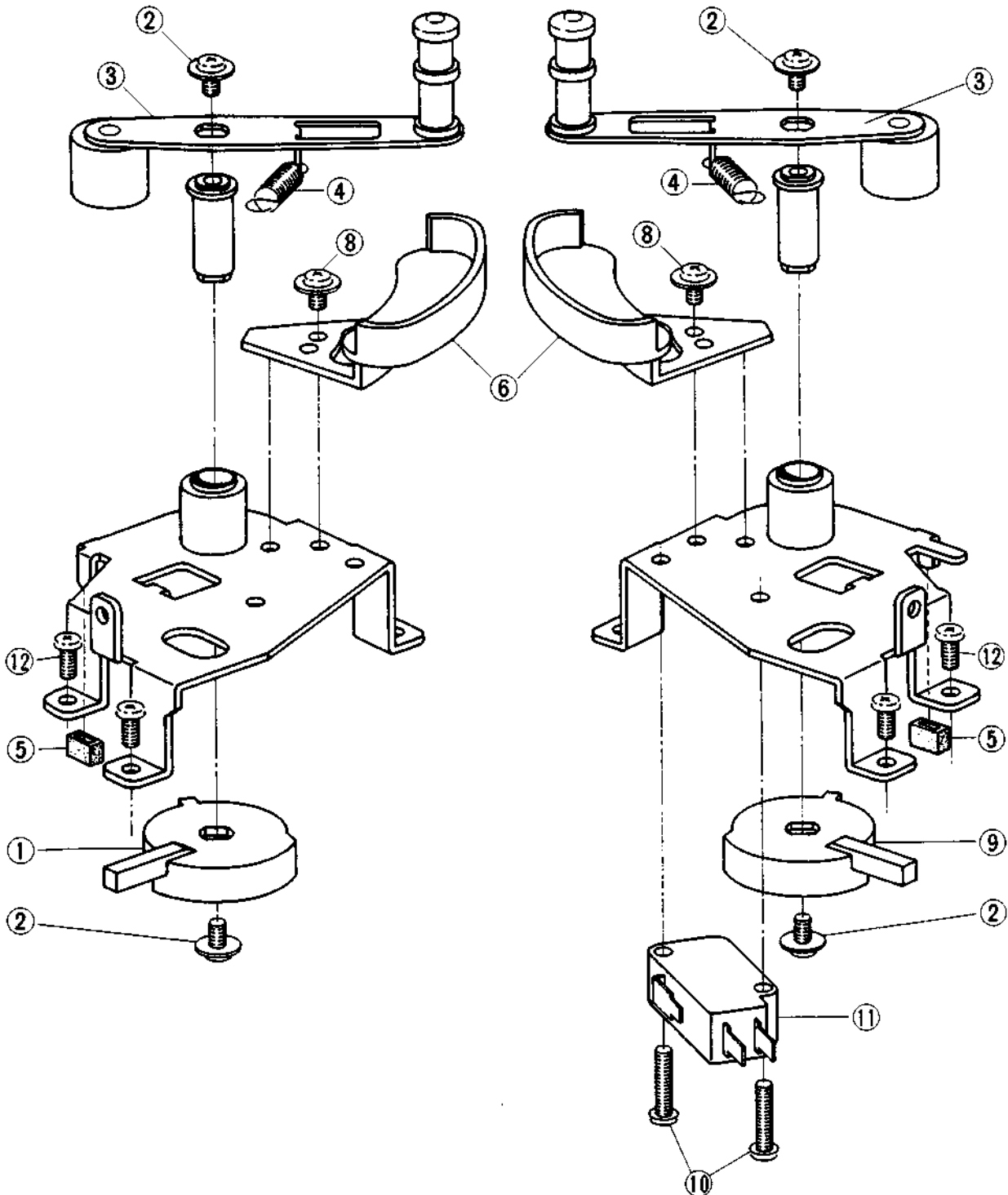

### 4. ARM TENSION BLOCK

REF. NO.	PARTS NO.	DESCRIPTION
4-1	SZ331421A	CAM TENSION ARM (L)
4-2	ZS265814	PAN30x05STL CMT PW080
4-3	BZB331423	ARM TENSION PART
4-4	ZG331427	SP PULL TENSION ARM (R)
4-5	MB282104	BRAKE RUBBER
4-6	SE331429A	ESCUTCHEON ARM

REF. NO.	PARTS NO.	DESCRIPTION
4-7x	SE331429B	ESCUTCHEON ARM (BL)
4-8	ZS379350	PAN30x06STL CMT
4-9	SZ331421B	CAM TENSION ARM (R)
4-10	ZS483502	PAN30x13STL CMT
4-11	ES331575	SW MICRO D2MV-01-1C1 CU
4-12	ZS379350	PAN30x06STL CMT

When ordering parts, please quote Parts Number, Description and Model Number.

# ROLLER BLOCK

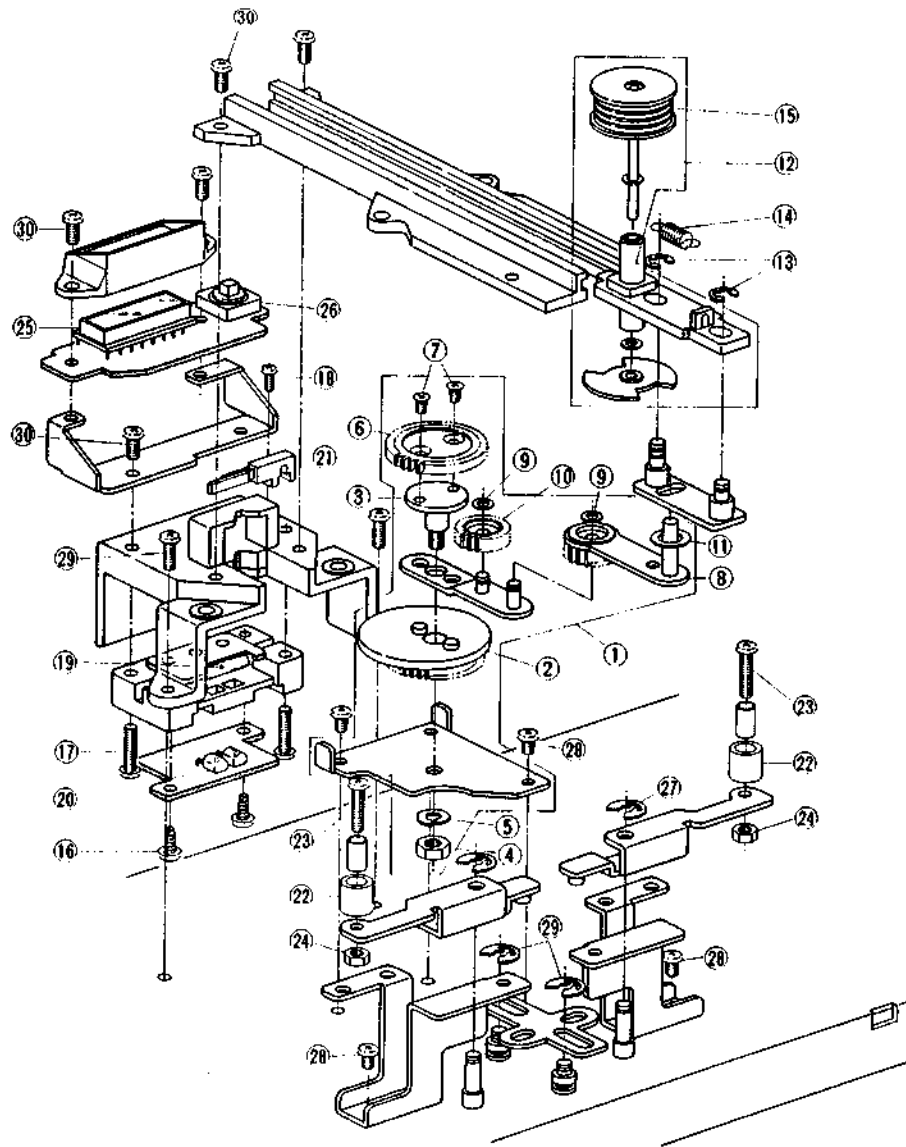

## 5. ROLLER BLOCK

REF. NO.	PARTS NO.	DESCRIPTION
<b>HOLDER LOADING ARM BLOCK</b>		
5-1	BZT1010A050A	HOLDER LOADING-ARM BLK GX-77
5-2	SZ338391	GEAR SET
5-3	MH331392	PROP 3 GEAR
5-4	ZW413188	N40STL CMT 1
5-5	ZW273892	TW40
5-6	SZ331394	GEAR FIX
5-7	ZS430413	CTS26x04STL CMT
5-8	BZB331398	ARM LOADING (A) PART
5-9	ZW202407	PUSH WASHER (B)
5-10	MZ331397	GEAR LOADING (B)
5-11	ZW260010	PW61x100x010PBR
<b>ROLLER BLOCK</b>		
5-12	BZT1010A070A	ROLLER BLK GX-77
5-13	ZW336595	RING E 300SUP ACP
5-14	ZG331407	SP PULL SET
5-15	MR331433	RING ROLLER
<b>HOLDER ROLLER BLOCK</b>		
5-16	ZS325495	T2BR30x06STL CMT
5-17	ZS419670	PAN30x13STL CMT
5-18	ZS537085	BID20x05STL CMT
<b>PC LAMP BLOCK</b>		
5-19	FL324540	PL H LEAD 12V 55MA (IN1)
<b>PC DETECTION BLOCK</b>		
5-20	ET324539	TR PHOTO PT-410C (TR1,2)
<b>LEAF SW BLOCK</b>		
5-21	FS283151	SW LEAF BSW-31NL 01-1 NO (SW905)
<b>LEVER PICK-UP BLOCK</b>		
5-22	M0606712	KJ STOPPER RUBBER
5-23	ZS483502	PAN30x13STL CMT
5-24	ZW516993	N30STL CMT 1
<b>PC COUNTER BLOCK</b>		
5-25	J11324082	IND FL SL-1406-20 CHARACTER (IN1)
5-26	FS328414	SW TACT KHC10901 (SW1)
<b>ASSEMBLY BLOCK</b>		
5-27	ZW290283	RING D 2R5SUP CMT
5-28	ZS417216	PAN30x04STL CMT
5-29	ZS421606	PAN30x08STL CMT
5-30	ZS379350	PAN30x06STL CMT

When ordering parts, please quote Parts Number, Description and Model Number.

MECHA BLOCK (1)

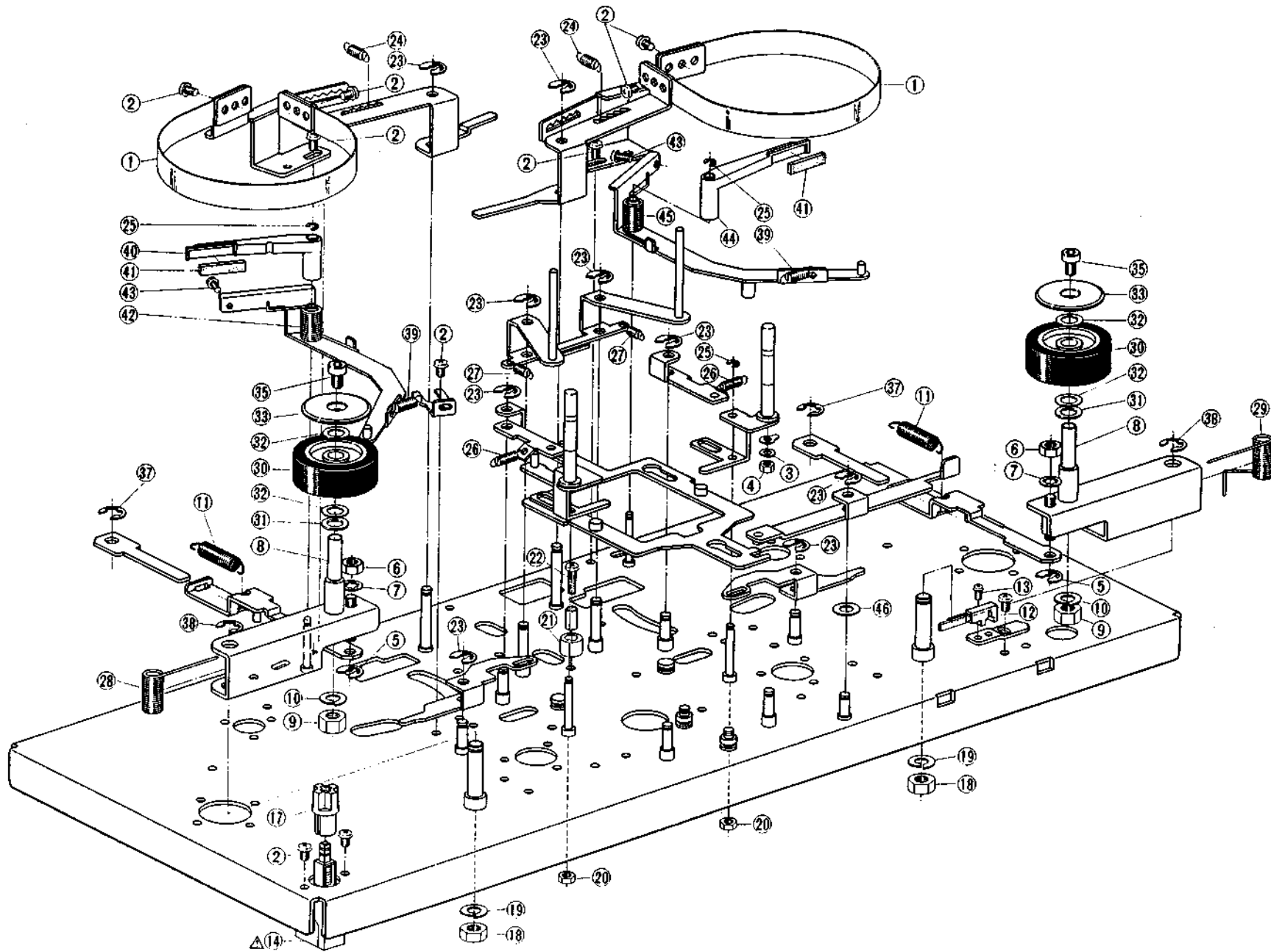

## 6. MECHA BLOCK (1)

REF. NO.	PARTS NO.	DESCRIPTION
<b>ARM BRAKE BLOCK</b>		
6-1	MZ331557	BRAKE BAND (B)
6-2	ZS417216	PAN30x04STL CMT
<b>ARM SHIFTER BLOCK</b>		
6-3	ZW609322	N26BRS 1
6-4	ZW307947	SW26
<b>ARM PLAY BLOCK</b>		
6-5	ZW290283	RING U 285SUP CMT
6-6	ZW413188	N40STL CMT 1
6-7	ZW273892	TW40
6-8	MH331308	PROP 6 PINCH ROLLER
6-9	ZW413278	N50STL CMT 1
6-10	ZW274026	SW50
6-11	ZG331352	SP PULL PINCH ROLLER
<b>HOLDER MUTE SW BLOCK</b>		
6-12	ES283151	SW LEAF BSW-31NL 01-1 NO (SW901)
6-13	ZS464703	BID20x04STL CMT
<b>POWER SW BLOCK</b>		
6-14	ES330422	Δ SW PUSH SDL1P 01-1 E (U,E,B,S,V)
6-15x	ES330420	Δ SW PUSH SDL1P 01-1 J (J)
6-16x	ES330421	Δ SW PUSH SDL1P 01-1 UC (C,A)
6-17	ML321550	JOINT
<b>ASSEMBLY BLOCK</b>		
6-18	ZW413278	N50STL CMT 1
6-19	ZW274026	SW50
6-20	ZW516993	N30STL CMT 1
6-21	SA331372	CUSHION STOPPER
6-22	ZS380046	PAN30x10STL CMT
6-23	ZW290283	RING U 285SUP CMT
6-24	ZG312996	SP T1-4.0/0.4-14.0 T1-110
6-25	ZW270088	RING E 190SUP CMT
6-26	ZG312947	SP T1-3.2/0.29-18.0 T1-063
6-27	ZG385457	FF LEVER RETURN SPRING
6-28	ZG331354A	SP TORSION P ROLLER RETURN (L)
6-29	ZG331354B	SP TORSION P ROLLER RETURN (R)
6-30	MP331347	ROLLER PINCH
6-31	ZW260076	PW61x100x050NYL
6-32	ZW376391	PW61x100x013PSL
6-33	SK331339A	CAP PINCH ROLLER
6-34x	SK331339B	CAP PINCH ROLLER (BL)
6-35	ZS613901	PANEL SCREW
6-36x	ZS306435	PANEL SCREW (C)
6-37	ZW270123	RING E400SUP CMT
6-38	ZW270134	RING E500SUP CMT
6-39	ZG331353	SP PULL TENSION SERVO
6-40	BZB331336A	ARM SERVO (A-L) PART
6-41	SZ331337	FELT SERVO
6-42	ZG331355A	SP TORSION SERVO ADJ (L)
6-43	ZS590804	PAN23x06STL CMT
6-44	BZB331336B	ARM SERVO (A-R) PART
6-45	ZG331355B	SP TORSION SERVO ADJ (R)
6-46	ZW259931	PW51x103x030PBR

MECHA BLOCK (2)

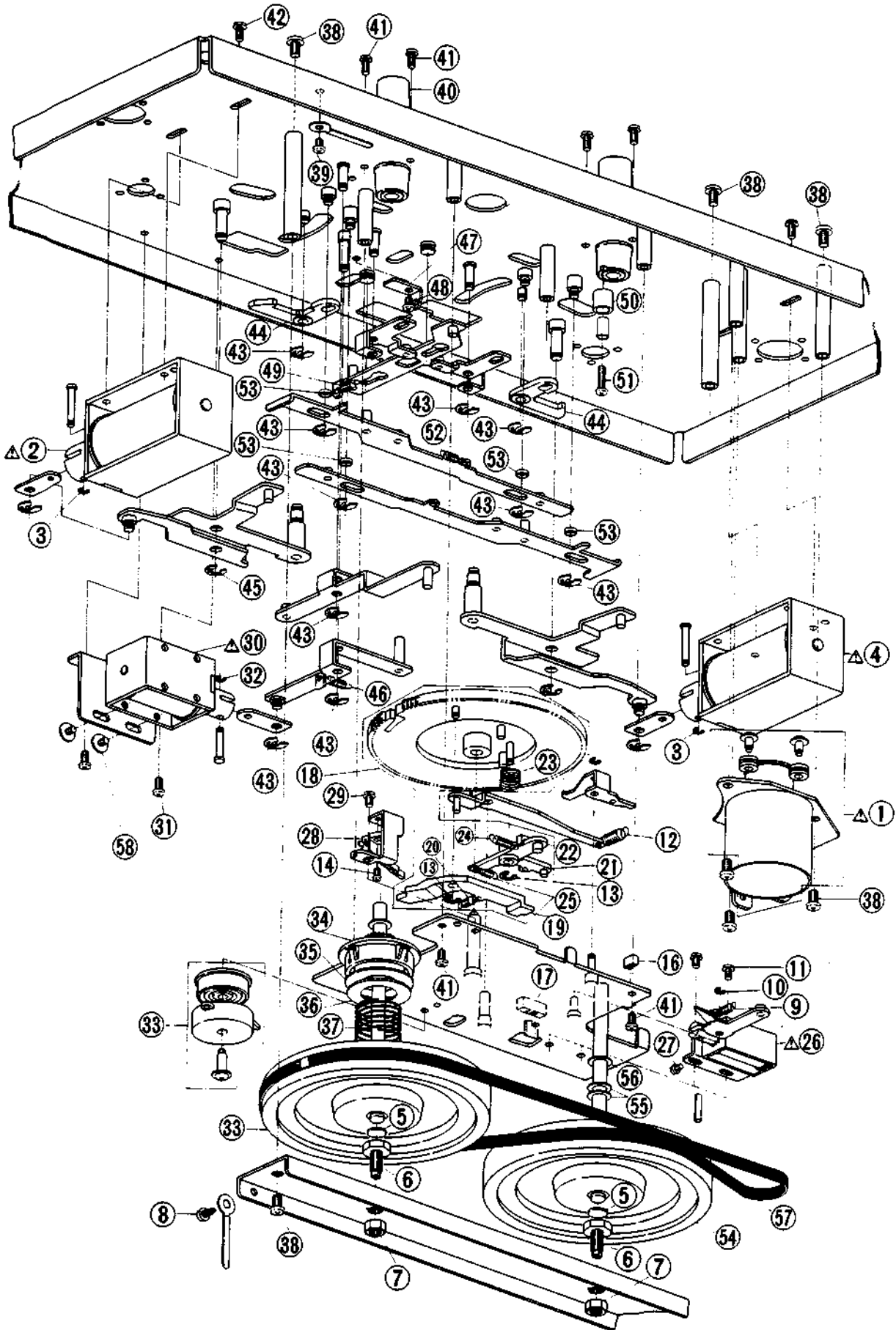

## 7. MECHA BLOCK (2)

REF. NO.	PARTS NO.	DESCRIPTION	REF. NO.	PARTS NO.	DESCRIPTION
<b>CAPSTAN MOTOR BLOCK</b>					
7-1	BMT1010A130A	△ CAPSTAN MOTOR BLK GX-77	7-51	ZS419670	PAN30x12STL CMT
<b>PR PLUNGER (L) BLOCK</b>					
7-2	EP331253	△ SOLENOID 1664TLT1 (TDS-16C-02) (SL901)	7-52	ZG336313	SP PULL PLAY SLIDE RETURN
7-3	ZW357164	RING E230SUP CMT	7-53	MV331325	ROLLER
<b>PR PLUNGER (R) BLOCK</b>					
7-4	EP331254	△ SOLENOID 1664TLT1 (TDS-16C-01) (SL902)	7-54	MI331311	FLYWHEEL (B)
<b>HOLDER FLYWHEEL BLOCK</b>					
7-5	ZW462205	WASHER (WITHOUT HOLE) 79x100NYL	7-55	ZW560215	PW61x100x050TFL
7-6	MZ585900	SHAFT SUPPORT	7-56	ZW331858	WASHER CAPSTAN
7-7	ZW413278	N50STL CMT 1	7-57	MB331350	BELT CAPSTAN
7-8	ZS325495	T2BR30x06STL CMT	7-58	ZS417216	PAN30x04STL CMT
<b>CHASSIS SUB BLOCK</b>					
7-9	ZG336117	SP PULL PLUNGER RETURN			
7-10	ZW270088	RING E 190SUP CMT			
7-11	ZS331530	BID30x40STL CMT			
7-12	ZG313043	SP T1-5.0/0.55-20.0 T1-156			
7-13	ZW270101	RING E300SUP CMT			
7-14	ZS417216	PAN30x04STL CMT			
7-15	BZT1010A270A	DAMPER (B) BLK GX-77			
7-16	MB282104	BRAKE RUBBER			
7-17	MB665561	TE STOPPER RUBBER			
<b>GEAR LOADING BLOCK</b>					
7-18	BZT1010A240A	GEAR LOADING BLK GX-77			
7-19	ML331379	LEVER TRIGGER			
7-20	ZG312923	SP T1-3.2/0.2-11.2 T1-040			
7-21	ML331381	LEVER LOADING (A)			
7-22	MC331382	LEVER LOADING (B)			
7-23	ZG332778	SP PUSH TRIGER			
7-24	ZG312946	SP T1-3.2/0.29-16.0 T1-062			
7-25	ZG312925	SP T1-3.2/0.2-14.0 T1-042			
<b>HOLDER PLUNGER BLOCK</b>					
7-26	EP331258	△ SOLENOID 0730TLT1 (SL901)			
7-27	ZS592378	PAN26x03STL CMT			
<b>LEAF SW (B) BLOCK</b>					
7-28	ES331259	SW LEAF BSW-810 01-1 NO(SW903)			
7-29	ZS460440	PAN20x04STL CMT			
<b>BRAKE PLUNGER BLOCK</b>					
7-30	EP331257	△ SOLENOID 1240PLT1 (SL904)			
7-31	ZS417137	BID30x04STL CMT			
7-32	ZW270088	RING E 190SUP CMT			
<b>FLYWHEEL (A) BLOCK</b>					
7-33	MI331310	FLYWHEEL (A)			
7-34	SZ331312	GEAR CAPSTAN			
7-35	SZ331313	CAP CLUTCH			
7-36	SZ331314	FELT CLUTCH			
7-37	ZG331315	SP PUSH CLUTCH			
<b>ASSEMBLY BLOCK</b>					
7-38	ZS417150	PAN40x06STL CMT			
7-39	ZS417216	PAN30x04STL CMT			
7-40	MV331361	HOLDER CAPSTAN SHAFT			
7-41	ZS379350	PAN30x06STL CMT			
7-42	ZS379405	BID30x06STL CMT			
7-43	ZW290283	RING U 285SUP CMT			
7-44	SZ331317	ARM SERVO RELEASE			
7-45	ZW270123	RING E400SUP CMT			
7-46	ZG312962	SP T1-3.2/0.45-16.0 T1-077			
7-47	ZG331324	HOLDER SPRING			
7-48	ZS417216	PAN30x04STL CMT			
7-49	ZG312945	SP T1-3.2/0.29-14.0 T1-061			
7-50	MB606712	KJ STOPPER RUBBER			

## 8. PRE AMP P.C BOARD BLOCK

REF. NO.	PARTS NO.	DESCRIPTION
8-1	BAT1010A520A	PC PRE AMP BLK GX-77(U) (U,J,C,A) (INCLUDING VR PCB)
8-2	BAT1010A520B	PC PRE AMP BLK GX-77(S) (S) (INCLUDING VR PCB)
8-3	BAT1010A520C	PC PRE AMP BLK GX-77(E) (E,B,V) (INCLUDING VR PCB)
<b>PRE AMP P.C BOARD BLOCK</b>		
8-IC1	EI213390	IC NJM4558D
8-TR1,2	ET308954	TR 2SC1844 E,F
8-TR3	ET603257	Δ TR 2SC1312S G,H
8-TR4,5	ET331279	TR 2SC1843 P,F SNP
8-TR6,7	ET200505	TR 2SC2603 E,F
8-TR8	ET308954	TR 2SC1844 E,F
8-TR9	ET603257	TR 2SC1312S G,H
8-TR10	ET200505	TR 2SC2603 E,F
8-TR11	ET603257	TR 2SC1312S G,H
8-TR12	ET331279	TR 2SC1843 P,F SNP
8-TR13	ET603257	TR 2SC1312S G,H
8-TR14	ET200505	TR 2SC2603 E,F
8-TR15	ET309353	TR 2SC2274 E,F
8-TR16	ET324134	TR 2SA984K E,F
8-TR17to22	ET200505	TR 2SC2603 E,F
8-TR23	ET200558	TR 2SA1115 E,F
8-TR24to27	ET200505	TR 2SC2603 E,F
8-TR28	ET603257	TR 2SC1312S G,H
8-TR29	ET375603	Δ TR 2SC1061 B,C
8-TR30	ET200505	TR 2SC2603 E,F
8-TR31,32	ET331196	Δ TR 2SD863 E
8-TR33,34	ET200505	TR 2SC2603 E,F
8-D1	ED316143	D SILICON H 1S2473HS F10
8-D2	ED331197	D ZENER H HZ6 C1
8-D3,4	ED301911	D SILICON H DS448
8-D5,6	ED316143	D SILICON H 1S2473HS F10
8-D7to10	ED301911	D SILICON H DS448
8-D11,12	ED308952	D GERMA V 1K34A-LR F07
8-D13	ED301911	D SILICON H DS448
8-D14	ED316143	D SILICON H 1S2473HS F10
8-D15	ED331198	D ZENER H HZ3 A1
8-D16,17	ED301911	D SILICON H DS448
8-J1	EJ331602	PHONE J 3P HLJ0327-020 6.3 20
8-J2	EJ319466	PIN J UA-1069 #01 P 4P (U,J,C,A)
8-J2	EJ308985	JACK PLATE DIN, PIN JACK 4P (E,B,S,V)
8-SW1	ES331204	SW SLIDE CL208E 2-08-02W
8-SW2	ES301435	SW SLIDE CL210E 2-10-02S
8-SW3	ES283072	SW SLIDE SSC22LP 2-02-02N
8-SW4	ES319448	SW LEVER 00420461 2-04-02N
8-SW5	ES331203	SW LEVER 00620387 2-06-02S
8-SW6	ES331205	SW LEVER 00820190 2-08-02S
8-VR1	EV331202	VR ROTARY 16P20x2G 3B103
8-VR2	EV331285	VR ROTARY 16P20x2H B502
8-VR5	EV336853	R S-FIX H KVSF807V 3P 103
8-VR6,7	EV336849	R S-FIX H KVSF807V 3P 203
8-VR8,9	EV341225	R S-FIX H KVSF807V 3P 503
8-VR10,11	EV336853	R S-FIX H KVSF807V 3P 103
8-VR12	EV336843	R S-FIX H KVSF807V 3P 303
8-L1	EO331190	COIL OSC 1 2330-065 100KHZ
8-L2,3	EO315758	COIL TUN 1 100S-431 100KHZ
8-FL1	EO319447	COIL TUN 1 GYD-100K 100KHZ
8-FL2	EO319495	COIL VARI 1 GYD-102 1MH
8-FL3	EO331280	COIL VARI 1 46-1072-11 22MH
8-RL1,2	EP249344	RELAY LEAD L24(M) 2NO 24V
8-TC1	EO330991	C S-FIX H ECR-BC090M11 8.0-90
8-FR1	ER319510	Δ R FUSE FR25SJ 1/4W 560J
8-FR2,3	ER331188	Δ R FUSE ERD2FC F10 1/4W 8R2J
8-R39	ER331281	R MF H 1/4W 2802F
8-R112	ER332362	R MF H F10 1/4W 2202G
8-R113	ER332363	R MF H F10 1/4W 3902G
8-R121	ER317595	R OMF H FS 2W 471J
8-C8	EC474671	C MC V FM 100K 500DC
8-C22	EC474671	C MC V FM 100K 500DC
8-C24	EC306987	C STY V F05 500 471J 50DC

REF. NO.	PARTS NO.	DESCRIPTION
8-C25	EC285513	C MC V FM 220K 500DC
8-C35	EC285513	C MC V FM 220K 500DC
8-C38	EC305422	C TT V D R33K 35DC
8-C56	EC201345	C MC V FM 300K 500DC
8-C75	EC325380	C PF V F10 PFH 332J 630DC

### VR P.C BOARD BLOCK

8-VR1	EV331199	VR ROTARY 16P10x1E 15A503
8-VR2	EV331201	VR ROTARY 16P20x2F A503



## 9. SYS. CON. P.C BOARD BLOCK

REF. NO.	PARTS NO.	DESCRIPTION
9-1	BAT1010A450A	PC SYSCON BLK GX-77 (EXCEPT A)
9-2	BAT1010A450B	PC SYSCON BLK (A)
9-IC1	EI331222	IC HD38800A42
9-IC2	EI331573	IC HD14042BP
9-TR1to10	ET331223	TR 2SA608KWBNP F,G SNP
9-TR11to22	ET331224	TR 2SC536KWBNP F,G SNP
9-TR23	ET307349	Δ TR 2SD794 P,Q
9-TR24	ET331224	TR 2SC536KWBNP F,G SNP
9-TR25	ET307349	Δ TR 2SD794 P,Q
9-TR26to28	ET331224	TR 2SC536KWBNP F,G SNP
9-TR29to37	ET331225	Δ TR 2SC2274K-WB E,F SNP
9-TR38	ET666415	Δ TR 2SB605 K,L
9-TR39	ET331224	TR 2SC536KWBNP F,G SNP
9-TR40	ET219857	TR 2SD438 E,F
9-TR41to43	ET331224	TR 2SC536KWBNP F,G SNP
9-TR45to53	ET331224	TR 2SC536KWBNP F,G SNP
9-D1to6	ED560913	D SILICON V 1S2473VE
9-D7to10	ED316143	D SILICON H 1S2473HS F10
9-D11,12	ED560913	D SILICON V 1S2473VE
9-D13	ED331227	D GERMA V 1K34A-UF SNP
9-D14to27	ED560913	D SILICON V 1S2473VE
9-D28to31	ED330622	D SILICON 1SR35-100VL 100/1.0A
9-D32,33	ED560913	D SILICON V 1S2473VE
9-D34	ED330622	D SILICON 1SR35-100VL 100/1.0A
9-D35	ED330989	D ZENER H HZ11 B2
9-D36to49	ED560913	D SILICON V 1S2473VE
9-D50,51	ED330622	D SILICON 1SR35-100VL 100/1.0A
9-D52	ED560913	D SILICON V 1S2473VE
9-L1	EO331574	COIL FIX 2 0749-471K 470μH
9-RL1	EP330425	RELAY POWER G2U-112P-US 1TR 12V
9-TH1,2	ED672232	Δ POSISTER PTH62BD3R3M
9-R134	ER331228	R MF V 1/4W 3012F
9-R136	ER331229	Δ R OMF V SNP 2W 121J
9-C13	EC314990	C STY V SNP CQFS 101J 50DC

## 10. POWER SUPPLY P.C BOARD BLOCK

REF. NO.	PARTS NO.	DESCRIPTION
10-1	BAT1010A430A	PC POWER BLK GX-77(U) (U)
10-2	BAT1010A430B	PC POWER BLK GX-77(J) (J)
10-3	BAT1010A430C	PC POWER BLK GX-77(C) (C,A)
10-4	BAT1010A430D	PC POWER BLK GX-77(E)(E,B,S,V)
10-IC1	EI331249	Δ IC μPC78M10H
10-TR1,2	ET639437	Δ TR 2SC945L Q,P
10-TR3	ET307349	Δ TR 2SD794 P,Q
10-TR4to6	ET639437	TR 2SC945L Q,P
10-TR7to10	ET317919	Δ TR 2SC1061 C,D
10-D1	ED319463	Δ D SILICON 4B4B41 100/4.0A
10-D2,3	ED330987	Δ D SILICON RB152 200/1.5A
10-D4	ED319463	Δ D SILICON 4B4B41 100/4.0A
10-D5	ED306109	Δ D SILICON W03B 100/1.0A
10-D6	ED313566	Δ D SILICON GP-25G 400/2.5A
10-D7	ED560913	D SILICON V 1S2473VE
10-D8	ED329051	D ZENER H HZ24 3
10-D9	ED315759	D ZENER H HZ16 1
10-D10	ED330989	D ZENER H HZ11 B2
10-R6	ER331250	R OMF V SNP 1W 472J
10-R12	ER331251	Δ R FUSE ERD2FC 1/4W 4R7J
10-C17	EC320548	Δ C CE V F 103Z 250AC (U,J)
10-C17	EC314688	Δ C CE V FZ 103P 125AC (C,A)
10-C17	EC327382	Δ C MP V 472M 250AC (E,B,S,V)

ASSEMBLY BLOCK

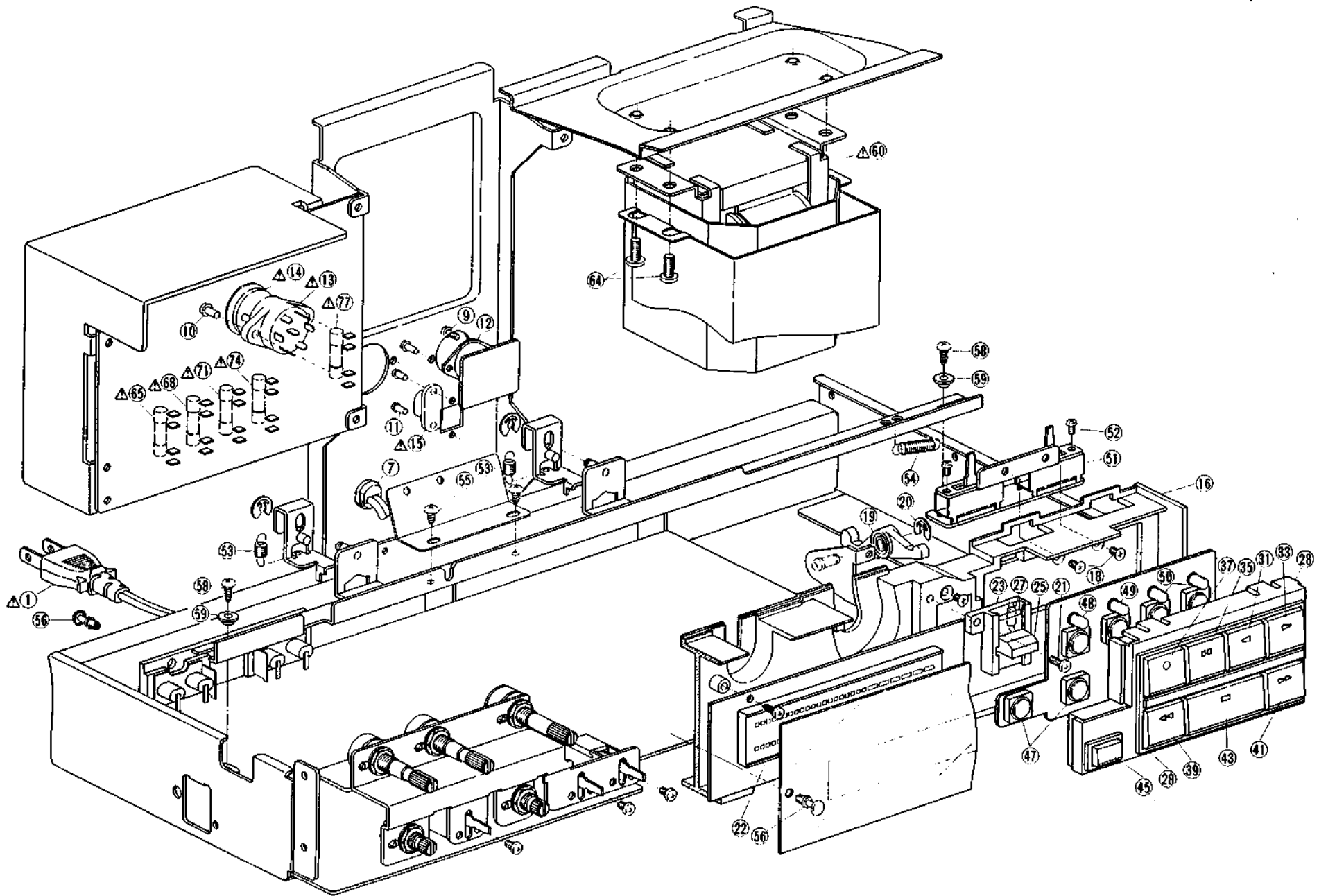

## 11. ASSEMBLY BLOCK

REF. NO.	PARTS NO.	DESCRIPTION	REF. NO.	PARTS NO.	DESCRIPTION
<b>POWER BLOCK</b>			11-49	ED330996	D LED GL-SHY5 YLW (D2)
11-1	EW306428	△ AC CORD 2 CORES KP-205A, VFF UCJ (U)	11-50	ED330995	D LED SLP-260C GRN (D3,4)
11-2x	EW306427	△ AC CORD 2 CORES KP-211, VFF J (J)	<b>PC SELECT BLOCK</b>		
11-3x	EW305691	△ AC CORD 2 CORES KP-8, SPT-1 UC (C,A)	11-51	ES331260	SW SLIDE SSB423 2-02-03N (SW1,2)
11-4x	EW313882	△ AC CORD 2 CORES KP-419C, LTCE-2F E (E,V)	11-52	ZS432843	PAN26x04STL CMT
11-5x	EW313884	△ AC CORD 2 CORES GTBS-2F 24/0.20x2 B (B)	<b>SLIDE CHANGE BLOCK</b>		
11-6x	EW201515	△ AC CORD 2 CORES KP-560, LTSA-2F S (S)	11-53	ZG313040	SP T1-5.0/0.55-14.0 T1-153
11-7	SZ631945	STRAIN RELIEF SR-4N-4 (U,J,C,A,E,S,V)	11-54	ZG313031	SP T1-5.0/0.32-28.0 T1-144
11-8x	EJ692908	STRAIN RELIEF SR-5N-4 (B)	11-55	ZS455207	T2BR30x05STL CMT
11-9	ZS479474	PAN26x05STL CMT	<b>ASSEMBLY BLOCK</b>		
11-10	ZS379350	PAN30x06STL CMT	11-56	ZW698308	RV NYL30x055 BL
11-11	ZS590804	PAN23x06STL CMT	11-57x	ZW263946	RV NYL40x050
<b>PC REMO. CON. BLOCK</b>			11-58	ZW331567	T2BR30x08STL CMT C080
11-12	EJ331215	DIN J TCS1881-101 P 8P	11-59	ZW625241	GRADUATED WASHER
<b>SOCKET SELECTOR BLOCK</b>			11-60	BT331218	△ TRANS POWER NFT-1 (U)
11-13	EJ262732	△ SOCKET SELECTOR S-I7223 U 7P	11-61x	BT331219	△ TRANS POWER NFT-2 (J)
11-14	EJ249467	△ PLUG VOLTAGE SELECTOR S-I7207 3P	11-62x	BT331221	△ TRANS POWER NFT-4 (C,A)
<b>PLUG CONNECTOR BLOCK</b>			11-63x	BT331220	△ TRANS POWER NFT-3 (E,B,S,V)
11-15	EJ310203	△ PLUG CONNECTOR EC0630-020 2P	11-64	ZS314702	ST BID40x10STL CMT
<b>CHASSIS AMP BLOCK</b>			11-65	EF601301	△ FUSE SEMKO T 250V 2A (F1) (U,E,B,S,V)
11-16	SP331443A	CHASSIS AMP	11-66x	EF306951	△ FUSE TSC A 250V 2.5A (F1) (J)
11-17x	SP331443B	CHASSIS AMP (BL)	11-67x	EF306956	△ FUSE TSC 125V 2.5A (F1) (C,A)
11-18	ZS444330	CTS30x04STL CMT	11-68	EF601964	△ FUSE SEMKO T 250V 1.60A (F2) (U,E,B,S,V)
11-19	TP331447	ARM CUE	11-69x	EF311839	△ FUSE TSC A 250V 1.6A (F2) (J)
11-20	ZW290283	RING U 285SUP CMT	11-70x	EF308847	△ FUSE TSC 125V 1.60A (F2)(C,A)
11-21	ZS331533	PT PAN30x08STL CMT	11-71	EF258344	△ FUSE SEMKO T 250V 0.80A (F3) (U,E,B,S,V)
11-22	ED331263	IND LE LT-1016 GRAPH	11-72x	EF309388	△ FUSE TSC A 250V 0.80A (F3)(J)
<b>GUIDE CUE BLOCK</b>			11-73x	EF309391	△ FUSE TSC 125V 0.08A (F3)(C,A)
11-23	SK331448A	GUIDE CUE KNOB	11-74	EF602550	△ FUSE SEMKO T 250V 1.25A (F4) (U,E,B,S,V)
11-24x	SK331448B	GUIDE CUE KNOB (BL)	11-75x	EF306949	△ FUSE TSC A 250V 1.25A (F4)(J)
11-25	SK331449A	KNOB CUE	11-76x	EF309392	△ FUSE TSC 125V 1.25A (F4)(C,A)
11-26x	SK331449B	KNOB CUE (BL)	11-77	EF602550	△ FUSE SEMKO T 250V 1.25A (F5) (U,E,B,S,V)
11-27	ZG312923	SP T1-3.2/0.2-11.2 T1-040	<b>OPERATION BLOCK</b>		
<b>OPERATION BLOCK</b>			11-28	SE331459A	ESCUTCHEON OPERATION KEY
11-28	SE331459A	ESCUTCHEON OPERATION KEY (BL)	11-29x	SE331459B	ESCUTCHEON OPERATION KEY (BL)
11-30x	SB331025	OPERATE BUTTON	11-30x	SB331025	OPERATE BUTTON
11-31	SBB603905	OPERATION KEY (A) PART	11-31	SBB603905	OPERATION KEY (A) PART
11-32x	SBB603901	OPERATION KEY (A)-BL PART	11-32x	SBB603901	OPERATION KEY (A)-BL PART
11-33	SBB603906	OPERATION KEY (B) PART	11-33	SBB603906	OPERATION KEY (B) PART
11-34x	SBB603902	OPERATION KEY (B)-BL PART	11-34x	SBB603902	OPERATION KEY (B)-BL PART
11-35	SBB603907	OPERATION KEY (C) PART	11-35	SBB603907	OPERATION KEY (C) PART
11-36x	SBB603903	OPERATION KEY (C)-BL PART	11-36x	SBB603903	OPERATION KEY (C)-BL PART
11-37	SBB603908	OPERATION KEY (F) PART	11-37	SBB603908	OPERATION KEY (F) PART
11-38x	SBB603904	OPERATION KEY (F)-BL PART	11-38x	SBB603904	OPERATION KEY (F)-BL PART
11-39	SB331026D	OPERATION KEY (D)	11-39	SB331026D	OPERATION KEY (D)
11-40x	SB331026K	OPERATION KEY (D)-BL	11-40x	SB331026K	OPERATION KEY (D)-BL
11-41	SB331026E	OPERATION KEY (E)	11-41	SB331026E	OPERATION KEY (E)
11-42x	SB331026L	OPERATION KEY (E)-BL	11-42x	SB331026L	OPERATION KEY (E)-BL
11-43	SB331027A	OPERATION KEY (G)	11-43	SB331027A	OPERATION KEY (G)
11-44x	SB331027B	OPERATION KEY (G)-BL	11-44x	SB331027B	OPERATION KEY (G)-BL
11-45	SB331028A	OPERATION KEY (H)	11-45	SB331028A	OPERATION KEY (H)
11-46x	SB331028B	OPERATION KEY (H)-BL	11-46x	SB331028B	OPERATION KEY (H)-BL
<b>PC OPERATION BLOCK</b>			11-47	ES315362	SW TACT AKC8S (SW1to8)
11-47	ES315362	SW TACT AKC8S (SW1to8)	11-48	ED330997	D LED GL-5PR5 RED (D1)
11-48	ED330997	D LED GL-5PR5 RED (D1)			

When ordering parts, please quote Parts Number, Description and Model Number.

## FINAL ASSEMBLY BLOCK

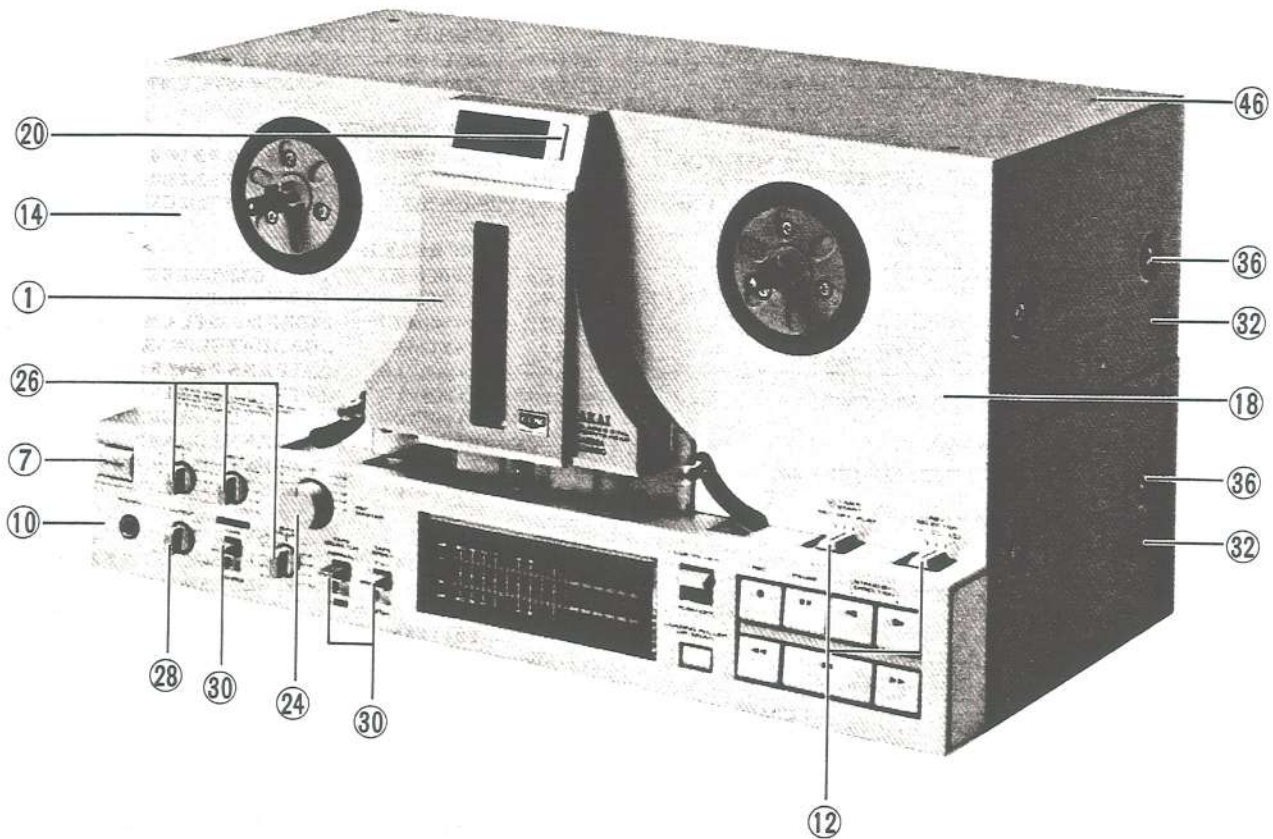

### 12. FINAL ASSEMBLY BLOCK

REF. PARTS NO. DESCRIPTION

#### COVER HEAD BLOCK

12-1 BCT1010A540A COVER HEAD BLK GX-77  
 12-2x BCT1010A540B COVER HEAD BLK GX-77-BL  
 12-3x BDB603561 LID HEAD COVER PART  
 12-4x BDB603563 LID HEAD COVER (BL) PART  
 12-5x MZ331479 ARM FRICTION (V)  
 12-6x ZG312965 SP T1-3.2/0.45-20.0 T1-079

#### CHASSIS AMP BLOCK

12-7 SK317468A KNOB PUSH (A)  
 12-8x SK317468B KNOB PUSH (A)-BL  
 12-9x ZG370350 REEL TABLE SPRING

#### FINAL ASSEMBLY BLOCK

12-10 BDB603414 PANEL AMP PART  
 12-11x BDB603416 PANEL AMP (BL) PART  
 12-12 SK331481A KNOB SELECTOR  
 12-13x SK331481B KNOB SELECTOR (BL)  
 12-14 SP331489A PANEL (L)  
 12-15x SP331489B PANEL (L)-BL  
 12-16x ZS379350 PAN30x06STL CMT  
 12-17x ZS325495 T2BR30x06STL CMT  
 12-18 SP331489C PANEL (R)  
 12-19x SP331489D PANEL (R)-BL  
 12-20 SK331486A KNOB RESET  
 12-21x SK331486B KNOB RESET (BL)

REF. PARTS NO. DESCRIPTION

12-22x ZS691277 PANEL SCREW  
 12-23x ZS322939 PANEL SCREW (B) (BL)  
 12-24 SK331487A KNOB REC  
 12-25x SK331487B KNOB REC (BL)  
 12-26 SK331109G KNOB (F)  
 12-27x SK331109E KNOB (D)-BL  
 12-28 SK331109F KNOB (E)  
 12-29x SK331109B KNOB (B)-BL  
 12-30 TC316384 LEVER (A)  
 12-31x TC316385 LEVER (A)-BL  
 12-32 SP331493A COVER  
 12-33x SP331493B COVER (BL)  
 12-34x SA331534 FOOT 2059  
 12-35x ZS301398 ST BID40x08STL CMT  
 12-36 ZS315878 XST BID40x08STL NI3  
 12-37x ZS310588 XST BID40x08STL BNI (BL)  
 12-38x SP331494B PANEL REAR BOARD GX-77(U)  
 12-39x SP331494C PANEL REAR BOARD GX-77(J)  
 12-40x SP331494D PANEL REAR BOARD GX-77(A,C)  
 12-41x SP331494A PANEL REAR BOARD GX-77(E,V)  
 12-42x SP331494E PANEL REAR BOARD GX-77(B,S)  
 12-43x ZS332469 ST PAN40x10STL CMT CUP  
 12-44x ZS331568 T2BR30x10STL CMT C080  
 12-45x ZW305013 RV POP32 (A)  
 12-46 SA331496A CUSHION RUBBER  
 12-47x SA331496B CUSHION RUBBER (BL)

When ordering parts, please quote Parts Number, Description and Model Number.

# INDEX

PARTS NO.	REF. NO.	PARTS NO.	REF. NO.	PARTS NO.	REF. NO.	PARTS NO.	REF. NO.
BAT1010A430A	10-1	ED672232	9-TH1,2	ET309353	8-TR15	MV331325	7-53
BAT1010A430B	10-2	EF258344	11-71	ET317919	10-TR7to10	MV331361	7-40
BAT1010A430C	10-3	EF306949	11-75x	ET324134	8-TR16	MZ331362	3-19
BAT1010A430D	10-4	EF306951	11-66x	ET324539	5-20	MZ331397	5-10
BAT1010A450A	9-1	EF306956	11-67x	ET331196	8-TR31,32	MZ331479	12-5x
BAT1010A450B	9-2	EF308847	11-70x	ET331223	9-TR1to10	MZ331557	6-1
BAT1010A520A	8-1	EF309388	11-72x	ET331224	9-TR11to22	MZ585900	7-6
BAT1010A520B	8-2	EF309391	11-73x	ET331224	9-TR24	SA331372	6-21
BAT1010A520C	8-3	EF309392	11-76x	ET331224	9-TR26to28	SA331496A	12-46
BCT1010A540A	12-1	EF311839	11-69x	ET331224	9-TR39	SA331496B	12-47x
BCT1010A540B	12-2x	EF601301	11-65	ET331224	9-TR41to43	SA331534	12-34x
BDB603414	12-10	EF601964	11-68	ET331224	9-TR45to53	SBB603901	11-32x
BDB603416	12-11x	EF602550	11-74	ET331225	9-TR29to37	SBB603902	11-34x
BDB603561	12-3x	EF602550	11-77	ET331279	8-TR4,5	SBB603903	11-36x
BDB603563	12-4x	EI213390	8-IC1	ET331279	8-TR12	SBB603904	11-38x
BHT1010A360A	2-2	EI331222	9-IC1	ET375603	8-TR29	SBB603905	11-31
BHT1010A370A	2-1	EI331249	10-IC1	ET603257	8-TR3	SBB603906	11-33
BMT1010A130A	7-1	EI331573	9-IC2	ET603257	8-TR9	SBB603907	11-35
BM331256	3-23	EJ249467	11-14	ET603257	8-TR11	SBB603908	11-37
BT331218	11-60	EJ262732	11-13	ET603257	8-TR13	SB331025	11-30x
BT331219	11-61x	EJ308985	8-J2	ET603257	8-TR28	SB331026D	11-39
BT331220	11-63x	EJ310203	11-15	ET639437	10-TR1,2	SB331026E	11-41
BT331221	11-62x	EJ319466	8-J2	ET639437	10-TR4to6	SB331026K	11-40x
BZB331336A	6-40	EJ331215	11-12	ET666415	9-TR38	SB331026L	11-42x
BZB331336B	6-44	EJ331602	8-J1	EV331199	8-VR1	SB331027A	11-43
BZB331398	5-8	EJ692908	11-8x	EV331201	8-VR2	SB331027B	11-44x
BZB331423	4-3	EL324540	5-19	EV331202	8-VR1	SB331028A	11-45
BZT1010A050A	5-1	EO315758	8-L2,3	EV331285	8-VR2	SB331028B	11-46x
BZT1010A070A	5-12	EO319447	8-FL1	EV336843	8-VR12	SE331429A	4-6
BZT1010A240A	7-18	EO319495	8-FL2	EV336849	8-VR6,7	SE331429B	4-7x
BZT1010A270A	7-15	EO331190	8-L1	EV336853	8-VR5	SE331459A	11-28
EC201345	8-C56	EO331280	8-FL3	EV336853	8-VR10,11	SE331459B	11-29x
EC285513	8-C25	EO331574	9-L1	EV341225	8-VR8,9	SK317468A	12-7
EC285513	8-C35	EP249344	8-RL1,2	EW201515	11-6x	SK317468B	12-8x
EC305422	8-C38	EP330425	9-RL1	EW305691	11-3x	SK331109B	12-29x
EC306987	8-C24	EP331253	7-2	EW306427	11-2x	SK331109E	12-7x
EC314688	10-C17	EP331254	7-4	EW306428	11-1	SK331109F	12-8
EC314990	9-C13	EP331257	7-30	EW313882	11-4x	SK331109G	12-6
EC320548	10-C17	EP331258	7-26	EW313884	11-5x	SK331339A	6-33
EC325380	8-C75	ER280710	3-18	EO330991	8-TC1	SK331339B	6-34x
EC327382	10-C17	ER317595	8-R121	HEH1305A010A	2-5	SK331448A	11-23
EC474671	8-C22	ER319510	8-FR1	HPH1005A010A	2-18	SK331448B	11-24x
EC474671	8-C8	ER331188	8-FR2,3	HRH1103A010A	2-11	SK331449A	11-25
ED301911	8-D3,4	ER331228	9-R134	HZ330925	2-19	SK331449B	11-26x
ED301911	8-D7to10	ER331229	9-R136	HZ331147	2-8	SK331481A	12-1
ED301911	8-D13	ER331250	10-R6	HZ331148A	2-10x	SK331481B	12-13x
ED301911	8-D16,17	ER331251	10-R12	HZ331148B	2-9	SK331486A	12-20
ED306109	3-17	ER331281	8-R39	HZ331149	2-15	SK331486B	12-21x
ED306109	10-D5	ER332362	8-R112	HZ331150A	2-17x	SK331487A	12-24
ED308952	8-D11,12	ER332363	8-R113	HZ331150B	2-16	SK331487B	12-25x
ED313566	10-D6	ES283072	8-SW3	HZ331151	2-21	SP331443A	11-6
ED315759	10-D9	ES283151	5-21	HZ331171A	2-4x	SP331443B	11-7x
ED316143	8-D1	ES283151	6-12	HZ331172	2-3	SP331489A	12-14
ED316143	8-D5,6	ES301435	8-SW2	MB282104	4-5	SP331489B	12-15x
ED316143	8-D14	ES315362	11-47	MB282104	7-16	SP331489C	12-18
ED316143	9-D7to10	ES319448	8-SW4	MB331350	7-57	SP331489D	12-19x
ED319463	10-D1	ES328414	5-26	MB331351	3-26	SP331493A	12-32
ED319463	10-D4	ES330420	6-15x	MB606712	5-22	SP331493B	12-33x
ED324082	5-25	ES330421	6-16x	MB606712	7-50	SP331494A	12-41x
ED329051	10-D8	ES330422	6-14	MB665561	7-17	SP331494B	12-38x
ED330622	9-D28to31	ES331203	8-SW5	MC331382	7-22	SP331494C	12-39x
ED330622	9-D34	ES331204	8-SW1	MH331308	6-8	SP331494D	12-40x
ED330622	9-D50,51	ES331205	8-SW6	MH331392	5-3	SP331494E	12-42x
ED330987	10-D2,3	ES331259	7-28	MI331310	7-33	SZ331312	7-38
ED330989	9-D35	ES331260	11-51	MI331311	7-54	SZ331313	7-35
ED330989	10-D10	ES331575	4-11	ML321550	6-17	SZ331314	7-36
ED330995	11-50	ET200505	8-TR6,7	ML331379	7-19	SZ331317	7-45
ED330996	11-49	ET200505	8-TR10	ML331381	7-21	SZ331337	6-48
ED330997	11-48	ET200505	8-TR14	MP331347	6-30	SZ331394	5-4
ED331197	8-D2	ET200505	8-TR17to22	MR331328	3-25	SZ331421A	4-1
ED331198	8-D15	ET200505	8-TR24to27	MR331432	3-1	SZ331421B	4-9
ED331227	9-D13	ET200505	8-TR33,34	MR331433	5-15	SZ338391	5-1
ED331263	11-22	ET200505	8-TR30	MS342000	3-8	SZ631945	11-7
ED560913	9-D11to6	ET200558	8-TR23	MTB603571	3-5	TC316384	12-30
ED560913	9-D11,12	ET219857	9-TR40	MTB604269	3-7x	TC316385	12-31x
ED560913	9-D14to27	ET307349	9-TR23	MTT1003A340A	3-2	TP331447	11-19
ED560913	9-D32,33	ET307349	9-TR25	MT300426	3-6	ZG206144	2-3
ED560913	9-D36to49	ET307349	10-TR3	MT331326	3-22	ZG255633	3-10
ED560913	9-D52	ET308954	8-TR1,2	MT458943	3-9	ZG312923	7-10
ED560913	10-D7	ET308954	8-TR8	MTS16565	3-11	ZG312923	11-27

# INDEX

PARTS NO.	REF. NO.	PARTS NO.	REF. NO.	PARTS NO.	REF. NO.	PARTS NO.	REF. NO.
ZG312925	7-25	ZS537085	5-18				
ZG312945	7-49	ZS590804	6-43				
ZG312946	7-24	ZS590804	11-11				
ZG312947	6-26	ZS592378	7-27				
ZG312962	7-46	ZS608095	2-20				
ZG312965	12-6x	ZS613901	6-35				
ZG312996	6-24	ZS691277	12-22x				
ZG313031	11-54	ZW259738	3-21				
ZG313040	11-53	ZW259931	6-46				
ZG313043	7-12	ZW260010	5-11				
ZG317496	3-3	ZW260076	6-31				
ZG331315	7-37	ZW263946	11-57x				
ZG331324	7-47	ZW270088	3-12				
ZG331352	6-11	ZW270088	6-25				
ZG331353	6-39	ZW270088	7-10				
ZG331354A	6-28	ZW270088	7-32				
ZG331354B	6-29	ZW270101	7-13				
ZG331355A	6-42	ZW270123	6-37				
ZG331355B	6-45	ZW270123	7-45				
ZG331407	5-14	ZW270134	6-38				
ZG331427	4-4	ZW273892	5-5				
ZG332778	7-23	ZW273892	6-7				
ZG336117	7-9	ZW274026	6-10				
ZG336313	7-52	ZW274026	6-19				
ZG370350	12-9x	ZW282407	5-9				
ZG385457	6-27	ZW290283	5-27				
ZS265814	4-2	ZW290283	6-5				
ZS301398	12-35x	ZW290283	6-23				
ZS302318	3-16	ZW290283	7-43				
ZS306435	6-36x	ZW290283	11-20				
ZS310588	12-37x	ZW305013	12-45x				
ZS314702	11-64	ZW307947	6-4				
ZS315878	12-36	ZW331567	11-58				
ZS322939	12-23x	ZW331858	7-56				
ZS323728	2-7	ZW336595	5-13				
ZS325495	5-16	ZW357164	7-3				
ZS325495	7-8	ZW376391	6-32				
ZS325495	12-17x	ZW413188	5-4				
ZS331111	3-15	ZW413188	6-6				
ZS331530	7-11	ZW413278	6-9				
ZS331533	11-21	ZW413278	6-18				
ZS331568	12-44x	ZW413278	7-7				
ZS332469	12-43x	ZW462205	7-5				
ZS336628	3-13	ZW516993	5-24				
ZS336629	3-14x	ZW516993	6-20				
ZS379350	3-20	ZW560215	7-55				
ZS379350	4-8	ZW609322	6-3				
ZS379350	4-12	ZW625241	11-59				
ZS379350	5-30	ZW698308	11-56				
ZS379350	7-41						
ZS379350	11-10						
ZS379350	12-16x						
ZS379405	7-42						
ZS380046	6-22						
ZS417137	7-31						
ZS417150	2-22						
ZS417150	7-38						
ZS417216	3-24						
ZS417216	5-28						
ZS417216	6-2						
ZS417216	7-14						
ZS417216	7-39						
ZS417216	7-48						
ZS417216	7-58						
ZS419670	2-14						
ZS419670	5-17						
ZS419670	7-51						
ZS421806	5-29						
ZS430413	5-7						
ZS432843	11-52						
ZS444330	11-18						
ZS455207	3-4x						
ZS455207	11-55						
ZS460440	2-12						
ZS460440	7-29						
ZS464703	6-13						
ZS477876	2-6						
ZS479471	11-9						
ZS483501	4-10						
ZS483501	5-23						

SECTION 3



# SCHEMATIC DIAGRAM

1. SCHEMATIC DIAGRAM OF ICs
2. GX-77 NO. 2-1 1622028A POWER & SYSCON SCHEMATIC DIAGRAM
3. GX-77 NO. 2-2 1622033A AMP SCHEMATIC DIAGRAM

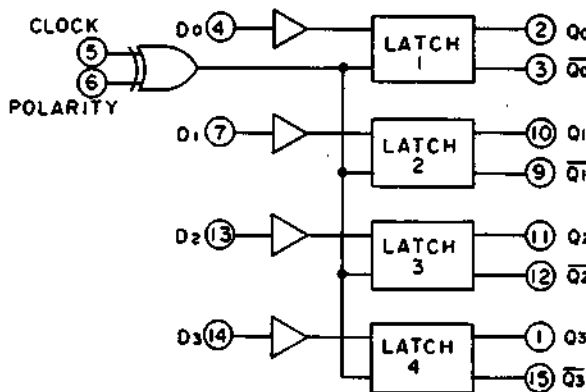
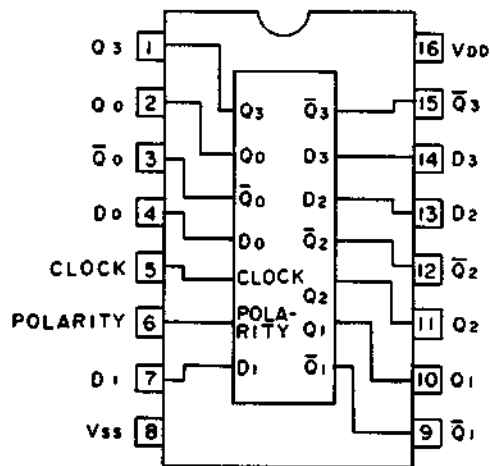
## HD14042BP



TRUTH TABLE

INPUT		OUTPUT
CLOCK	POLARITY	Q
L	L	CATA
	L	LATCH
H	H	DATA
	H	LATCH

H: HIGH LEVEL  
L: LOW LEVEL

## NJM4558D

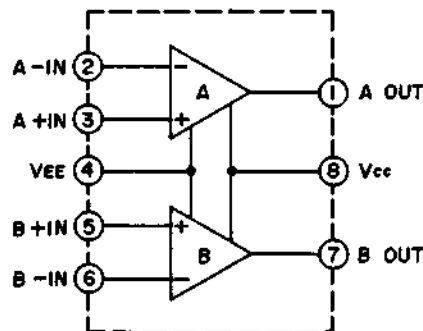

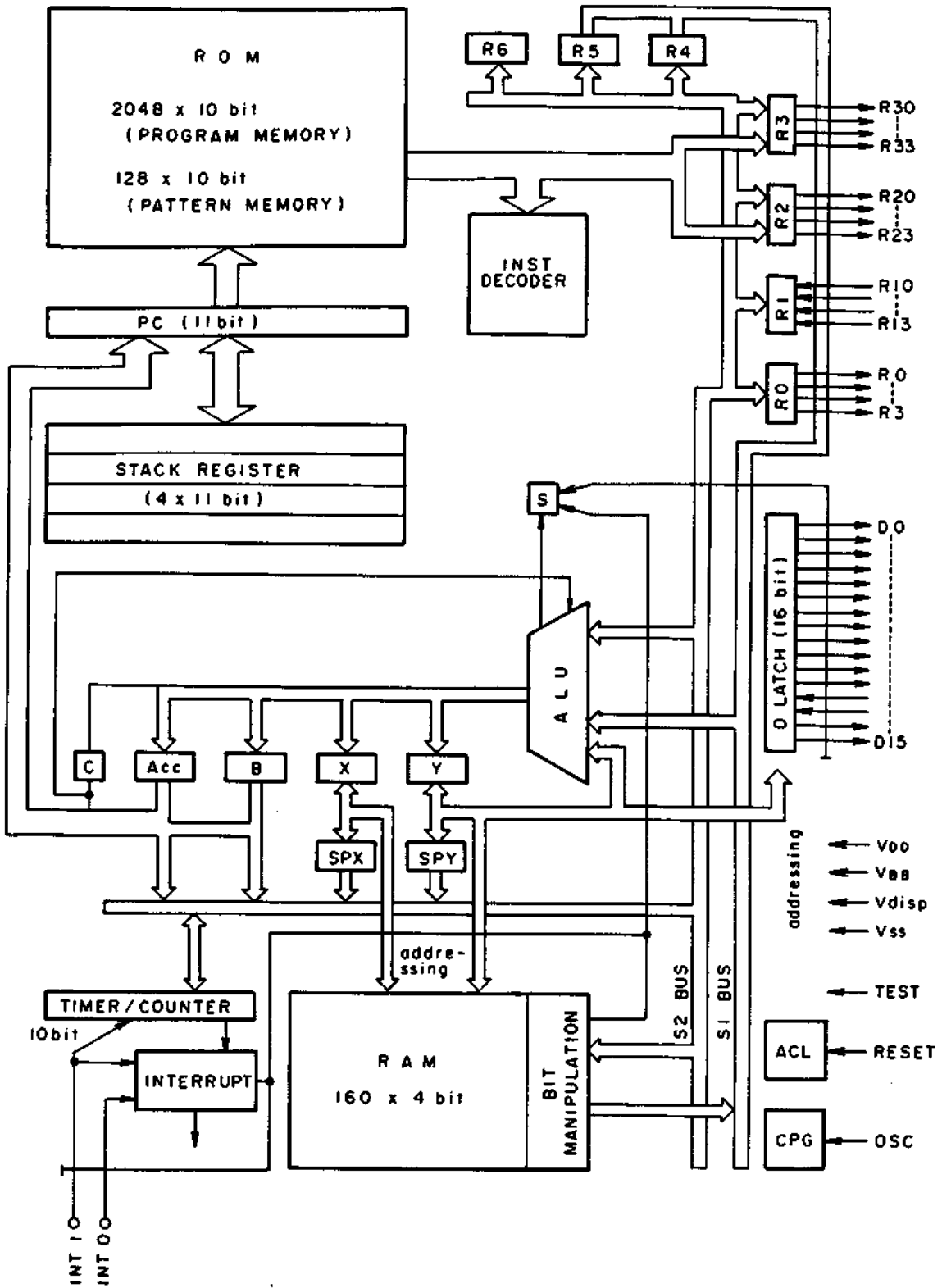



GX-77

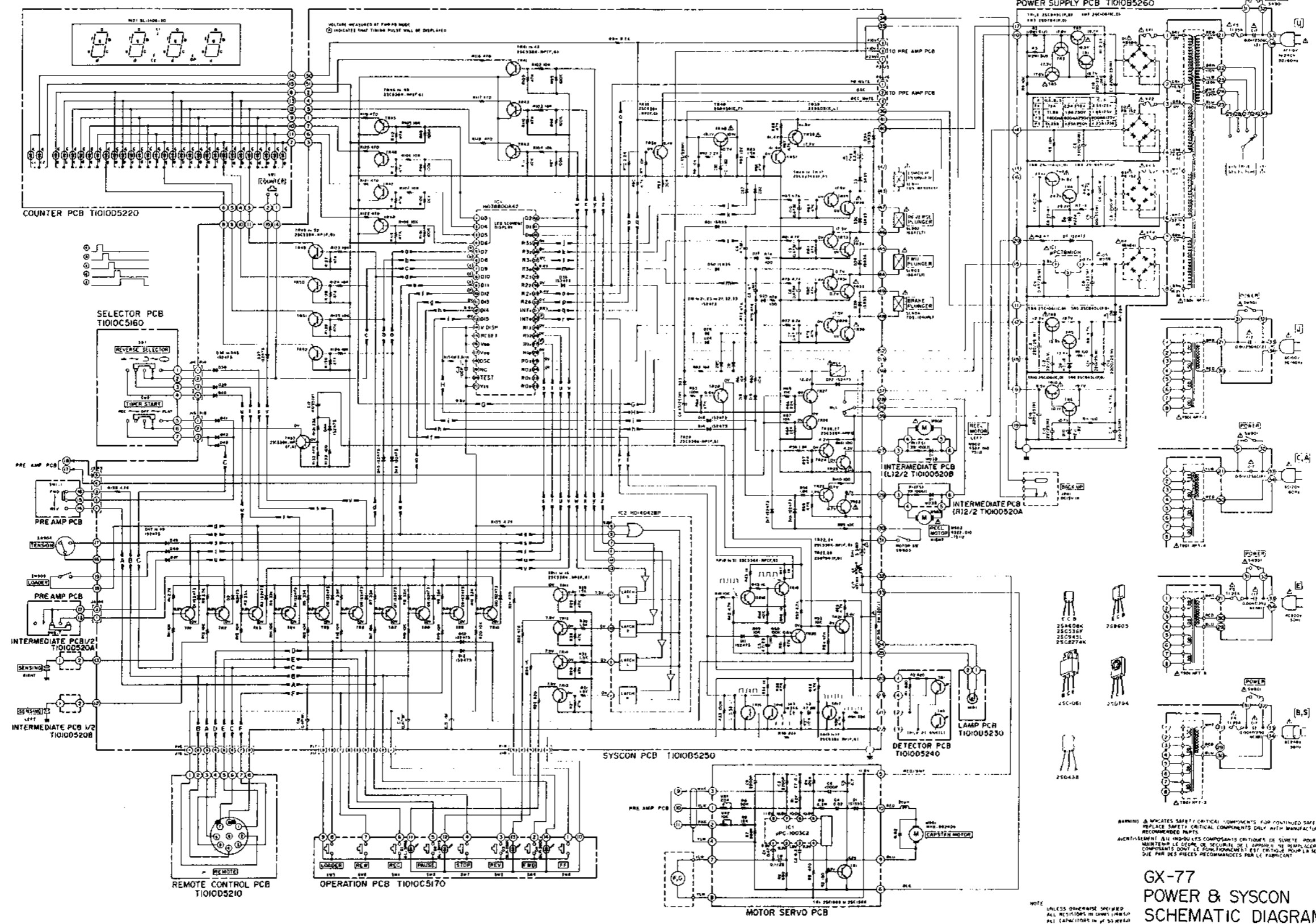

WARNING & INDICATES SAFETY CRITICAL COMPONENTS FOR CONTINUED SAFETY.  
 REPLACE SAFETY CRITICAL COMPONENTS ONLY WITH MANUFACTURER'S  
 RECOMMENDED PARTS.  
 AVERTISSEMENT & INDICATES COMPOSANTS CRITIQUES DE SURETE POUR  
 MAINTENIR LE DEGRE DE SECURITE DE L'APPAREIL. NE REMPLACEZ LES  
 COMPOSANTS DONT LE FOND FONCTIONNEL EST CRITIQUE POUR LA SECURITE  
 QUE PAR DES PIECES RECOMMANDEES PAR LE FABRICANT.

**GX-77**  
**POWER & SYSCON**  
**SCHEMATIC DIAGRAM**  
 NO. 2-1 1622028A

NOTE  
 UNLESS OTHERWISE SPECIFIED  
 ALL RESISTORS IN OHMS UNLESS  
 ALL CAPACITORS IN μF UNLESS

00124

