

VS-205EK
 VS-240EA/EG/EK/ES/EO
 VS-245ES

AKAI SERVICE MANUAL

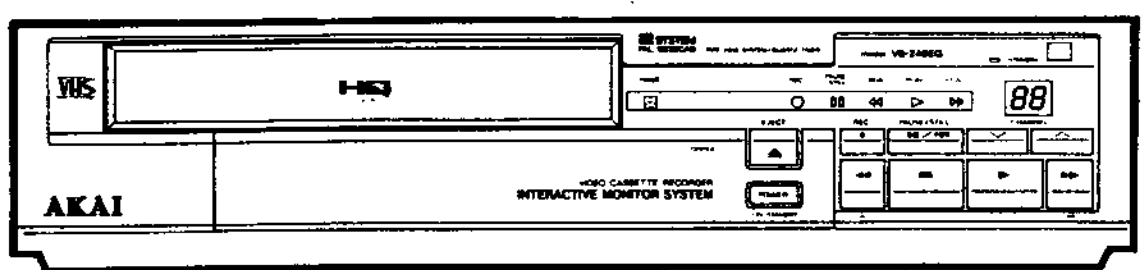

VIDEO CASSETTE RECORDER

MODEL **VS-205EK**

MODEL **VS-240** EA/EG/EK/ES/EO
 /EO(Y3)/EV/EZ

MODEL **VS-245ES**

SPECIFICATIONS

Format	VHS standard	Recording (line input)	PAL, CCIR (System B, G, I)
Video recording system	Rotary, slant azimuth two-head helical scan system	Playback (line output)	PAL, CCIR (System B, G, I)
Rotary heads	Two video heads	Video	
RF input EA	System B, G VHF ch 0 - 5, 5A, 6 - 11, UHF ch 21 - 69	Line input level	0.5 - 2.0 Vp-p/75 ohms, unbalanced
EG/EV	System B, G VHF ch 2 - 12, UHF ch 21 - 69	Line output level	1.0 Vp-p/75 ohms, unbalanced
EK	System I UHF ch 21 - 69	S/N ratio	more than 45 dB
EO	VHF Low ch 2 - 4, S1 - S3 High ch M1 - M10, 5 - 12, U1 - U10	Horizontal resolution	more than 250 lines
ES	System I VHF ch A - J (Ireland) ch 4 - 13 (South Africa)	Audio	
EZ	System B, G VHF ch 1 - 9, UHF ch 21 - 69	Line input level	-8 dBm/50 K ohms, unbalanced
RF output EA	System B type modulation VHF ch 0, 1 switchable (preset ch 1)	Line output level	-6 dBm/ 1 K ohms, unbalanced
EG/EO	System G type modulation UHF ch 30 - 39 adjustable (preset ch 36)	S/N ratio	more than 40 dB
EG/ES	System I type modulation UHF ch 30 - 39 adjustable (preset ch 36)	Frequency response	70 - 10,000 Hz
EV	System B type modulation VHF ch 3, 4 switchable (preset ch 4)	Recording/playback time	240 min. with E-240 cassette
EZ	System B type modulation VHF ch 2, 3 switchable (preset ch 3)	Tape speed	23.39 mm/sec.
		Quick finder	approx. 7 times normal speed
		FF, REW time	approx. 5 min. with E-240 cassette
		Timer	
		Program	4 program/2 week and sleep timer
		Clock reference	Quartz crystal
		Display	TV screen (Tape counter, Timer etc.)
		Power requirements	
		EA	240 V AC, 50 Hz
		EG	110/220 V AC, 50/60 Hz
		EK	200/240 V AC, 50 Hz
		EO	220 V AC, 50 Hz
		ES	220/250 V AC, 50 Hz
		EV	115/230 V AC, 50/60 Hz
		EZ	230 V AC, 50 Hz
		Power consumption	28 W
		Operating temperature	5°C - 40°C
		Dimensions	425 (W) x 95 (H) x 345 (D) mm
		Weight	5.9 Kg

* For improvement purposes, specifications and design are subject to change without notice.

★ SAFETY INSTRUCTIONS

PRECAUTIONS DURING SERVICING

- Parts identified by the Δ symbol parts are critical for safety. Replace only with parts number specified.
- In addition to safety, other parts and assemblies are specified for conformance with such regulations as those applying to spurious radiation. These must also be replaced only with specified replacements.
Examples: RF converters, tuner units, antenna selector switches, RF cables, noise blocking capacitors, noise blocking filters, etc.
- Use specified internal wiring. Note especially:
 - 1) Wires covered with PVC tubing
 - 2) Double insulated wires
 - 3) High voltage leads
- Use specified insulating materials for hazardous live parts. Note especially:
 - 1) Insulation Tape
 - 2) PVC tubing
 - 3) Spacers (Insulating Barriers)
 - 4) Insulation sheets for transistors
 - 5) Plastic screws for fixing microswitch (especially in turntable)
- When replacing AC primary side components (transformers, power cords, noise blocking capacitors, etc.), wrap ends of wires securely about the terminals before soldering.

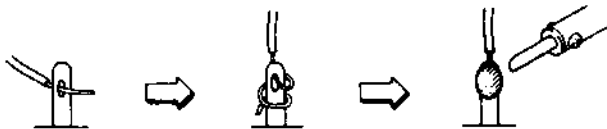

- Observe that wires do not contact heat producing parts (heatsinks, oxide metal film resistors, fusible resistors, etc.).

- Check that replaced wires do not contact sharp edged or pointed parts.
- Also check areas surrounding repaired locations.
- Use care that foreign objects (screws, solder droplets, etc.) do not remain inside the set.

SAFETY CHECK AFTER SERVICING

Confirm the specified insulation resistance between power cord plug prongs and externally exposed parts of the set is greater than 10 M ohms. but for equipment with external antenna terminals (tuner, receiver, etc.) and is intended for **C** or **A**, specified insulation resistance should be headphone jacks line-in-out jacks etc. more than 2.2 M ohms (ground terminals, microphone jacks).

PRECAUTION FOR THE LITHIUM BATTERY

The LITHIUM BATTERY employed for memory Back up has a explosive probability when the BATTERY itself is excessive heated.

IN CASE OF REPLACING: RESOLDER and SOLDER AS RECOMMENDED WAY.

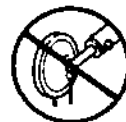

(DANGER)



(RECOMMENDED WAY)

★ INFORMATION

SYMBOLS FOR PRIMARY DESTINATION

Set the VOLTAGE SELECTOR with a screwdriver to voltage for your area.

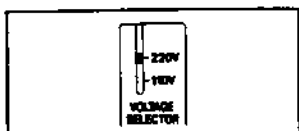

VS-240EG

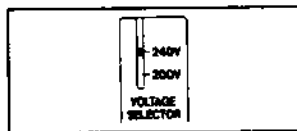

VS-240EK

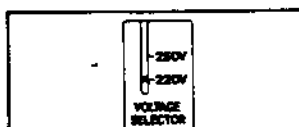

VS-240ES

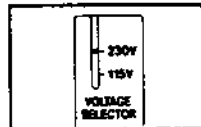

VS-240EV

VOLTAGE CONVERSION

(MODEL VS-240EG/EK/ES/EV)

Alphabet indicates the destination of the units as listed below.

Symbols	Principal Destinations
A	USA
B	UK
C	Canada
E	Europe (except UK)
J	Japan
S	Australia
V	W. Germany only
U	Universal Area
Y*	Custom version

I. SAFETY LOCK (CHILD LOCK) SYSTEM

This VCR can be locked to prevent access by small children.

This feature can be operated by the REMOTE CONTROL only.

To lock : With the VCR POWER ON, depress and hold the remote control's STOP button for 4 seconds. An "L" will momentarily flash the CHANNEL display. Tape play will not function until the VCR is unlocked.

To unlock: Depress and hold the remote control's PLAY button for 4 seconds. Even if the POWER is turned off, the VCR will remain locked until released.

II. RESETTING MEMORY OF CPU

2-1. RESETTING OF OPERATION/SYSCON CPU (ONLY)

- 1) Disconnect AC power cord then disconnect P951 (back up) on the OPERATION PC Board.
- 2) Connect P951 back in its place.
- 3) The OPERATION and SYSCON CPU are reset with above steps.

NOTE: With this procedure, preset TV stations are not reset. For resetting of TV stations, refer to 2-2.

2-2. RESETTING OF TV STATIONS AND OPERATION/SYSCON CPU

- 1) Disconnect AC power cord.
- 2) While holding "REC" and "REW" buttons depressed simultaneously, connect AC power cord. The TIMER display will flash.
- 3) Disconnect AC power cord again to stop flashing TIMER display.
- 4) Preset TV stations and OPERATION/SYSCON CPU are reset with above steps.

The chart below shows each function after the reset.

CLOCK	SUN 0:00 00
CHANNEL	Displays lowest channel number
DISPLAY	Flashes clock display
CHILD LOCK	The same condition as before reset
TAPE COUNTER	0000
TV/VCR	TV

III. DISASSEMBLY

In case of trouble, etc. necessitating dismantling, please dismantle in the order shown in the photographs. Reassemble in reverse order.

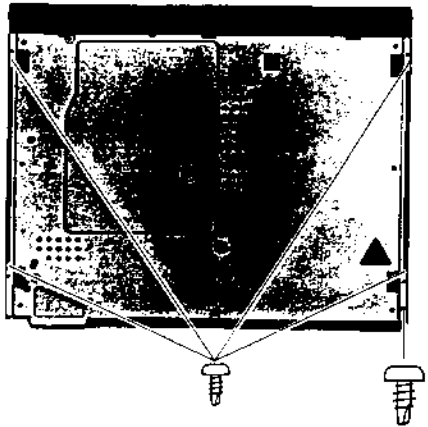
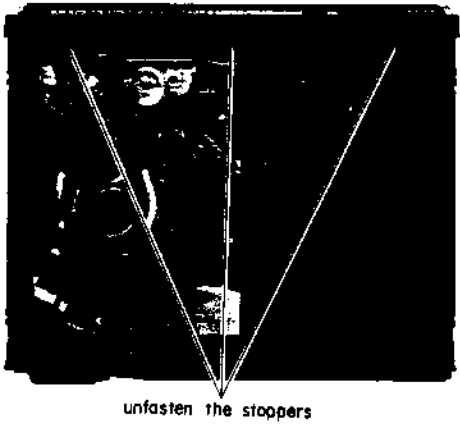
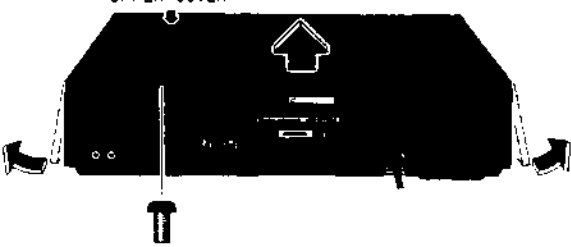
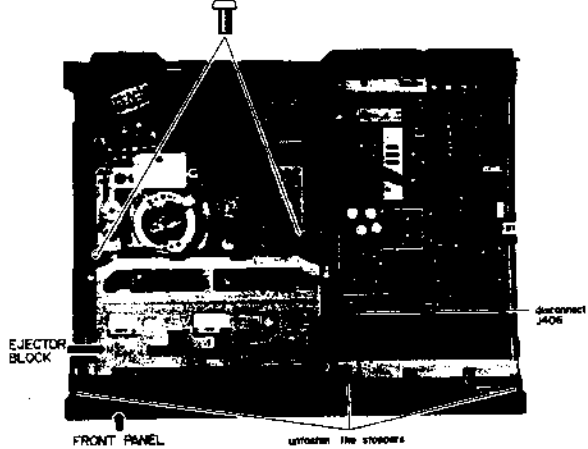
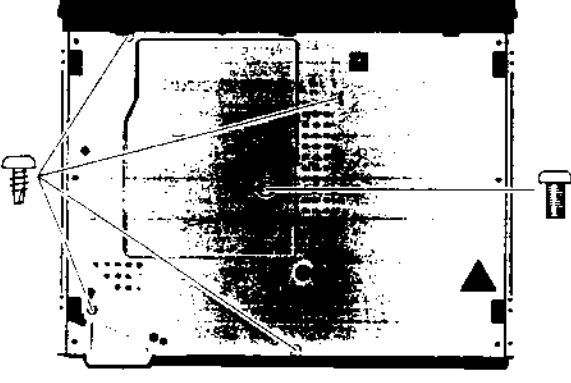
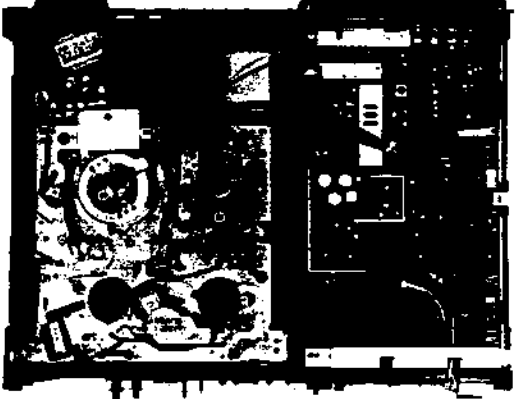
<p>1 Removal of Upper Cover</p> 	<p>4 Removal of Front Panel & Ejector Block</p>  <p>unfasten the stoppers</p>
<p>2</p>  <p>UPPER COVER</p>	<p>5</p>  <p>EJECTOR BLOCK</p> <p>FRONT PANEL</p> <p>disconnect J406</p> <p>unfasten the stoppers</p>
<p>3 Removal of Bottom Cover</p> 	<p>6</p> 

IV. CONTROLS

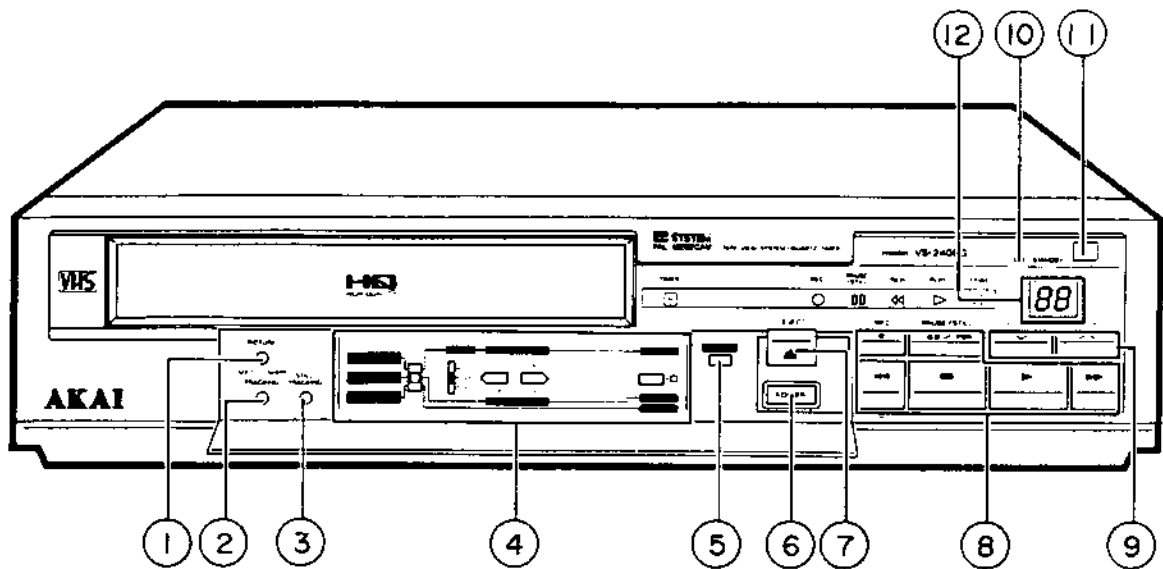

Fig. 4-1 Front View

- | | |
|-------------------------------|----------------------------|
| 1. SOFT/SHARP PICTURE CONTROL | 7. EJECT BUTTON |
| 2. TRACKING CONTROL | 8. TAPE TRANSPORT BUTTONS |
| 3. STILL TRACKING CONTROL | 9. CHANNEL UP/DOWN BUTTONS |
| 4. TUNING CONTROLS | 10. STAND-BY INDICATOR |
| 5. TIMER BUTTON | 11. REMOTE CONTROL SENSOR |
| 6. POWER BUTTON | 12. CHANNEL DISPLAY |

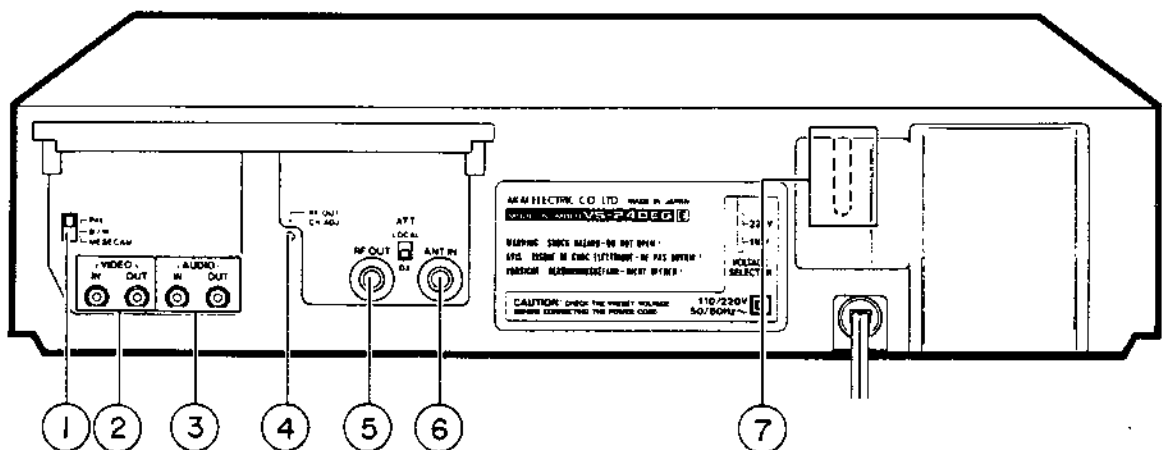

Fig. 4-2 Rear View

- | | |
|---------------------------------------|---|
| 1. VIDEO MODE SELECTOR | 5. RF OUT TERMINAL |
| 2. VIDEO IN/OUT JACKS | 6. ANT JACK |
| 3. AUDIO IN/OUT JACKS | 7. VOLTAGE SELECTOR (EG/EK/ES/EV models only) |
| 4. RF OUT CH. ADJ./RF OUT CH SELECTOR | |

* Illustrated employed model VS-240EG.

V. PRINCIPAL PARTS LOCATION

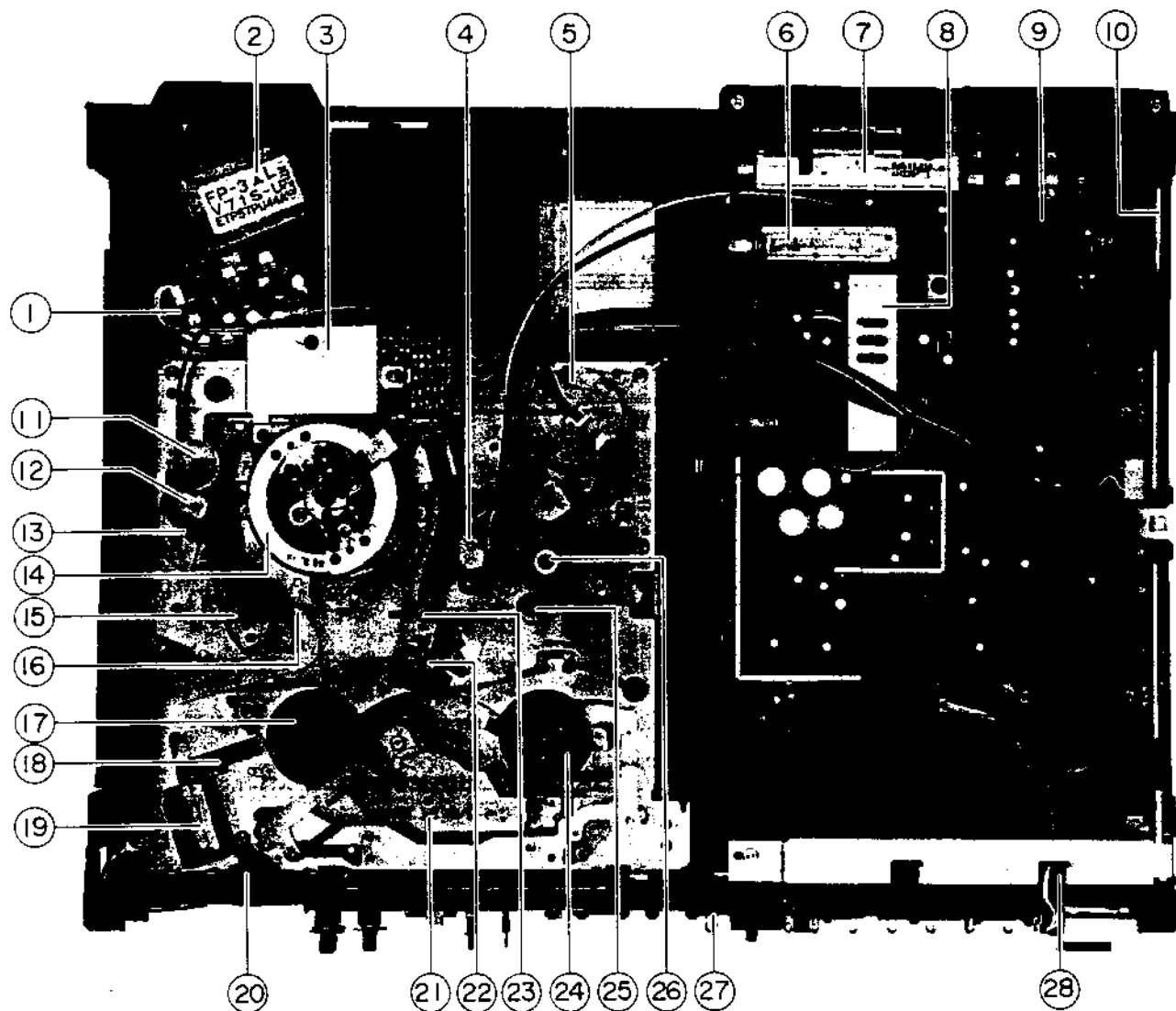

Fig. 5-1 Top View

- | | |
|---------------------------|--------------------------|
| 1. TRANS PCB | 15. LOADING LEADER LEFT |
| 2. POWER TRANSFORMER | 16. TENSION ARM |
| 3. PREAMP PCB | 17. SUPPLY REEL TABLE |
| 4. AUDIO/CONTROL HEAD | 18. SYNCHRO BELT |
| 5. CAPSTAN MOTOR | 19. LOADING MOTOR |
| 6. TUNER UNIT | 20. REC SAFETY SWITCH |
| 7. RF CONVERTER | 21. TAKE UP GEAR BLOCK |
| 8. VIF UNIT | 22. SENSOR LED |
| 9. MAIN PCB | 23. LOADING LEADER RIGHT |
| 10. MAIN (VIDEO) PCB | 24. TAKE-UP REEL TABLE |
| 11. IMPEDANCE ROLLER | 25. CAPSTAN SHAFT |
| 12. FULL TRACK ERASE HEAD | 26. PINCH ROLLER |
| 13. SUPPLY TAPE GUIDE | 27. OPERATION(A) PCB |
| 14. HEAD DRUM BLK | 28. OPERATION(B) PCB |

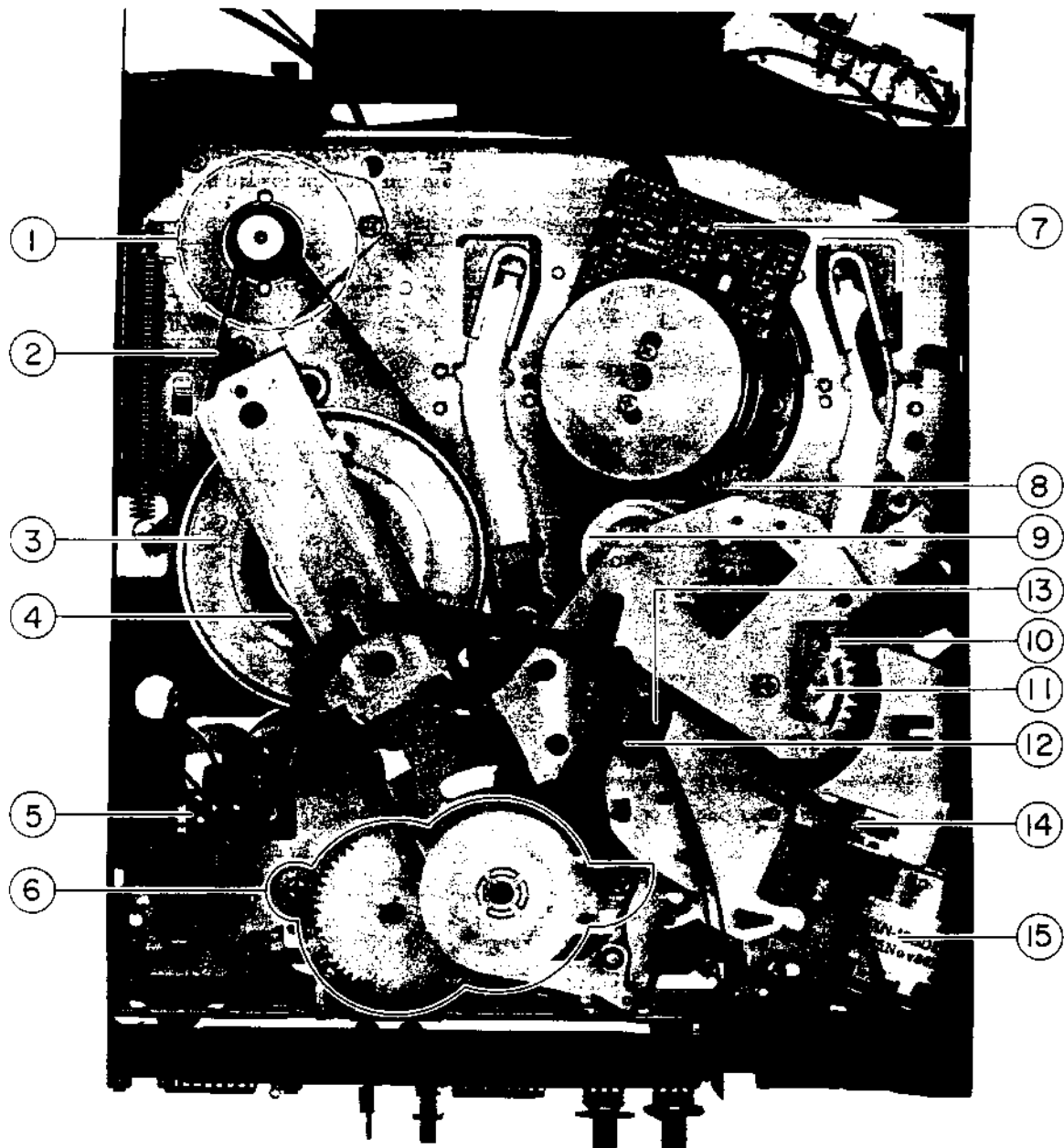

Fig. 5-2 Bottom View

1. CAPSTAN MOTOR
2. CAPSTAN BELT
3. CAPSTAN FLYWHEEL
4. IDLER BELT
5. REEL SENSOR PCB
6. TAKE-UP GEAR BLOCK
7. DRUM MOTOR BLOCK
8. SUPPLY LOADING GEAR

9. TAKE-UP LOADING GEAR
10. EJECT CAM GEAR
11. EJECT SWITCH
12. ROTARY ENCODER
13. MAIN GEAR CAM
14. SYNCHRO BELT
15. LOADING MOTOR

VI. MECHANICAL ADJUSTMENT

6-1. BACK TENSION ADJUSTMENT

- 1) Remove the EJECTOR BLK. and disconnect P406 from MAIN PC BOARD.
- 2) Depress the POWER button on the Front Panel to Function ON.
- 3) Short pin ③ (C, SW, B) and pin ⑤ (GND) of P406 with a tweezer or jumperwire as shown in Fig. 6-1 to maintain the tape loaded mode without Ejector BLK.

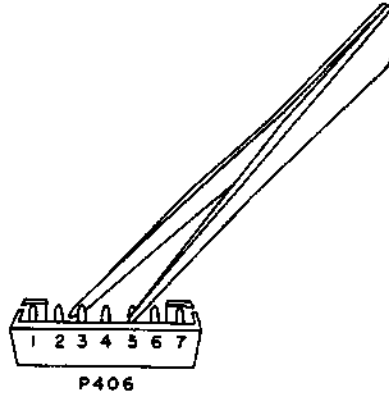

Fig. 6-1

- 4) Set the Back Tension jig (AT-751181) on the Reel tables and put some weight on the Back Tension jig as a stabilizer.
- 5) Press the PLAY button, then check and adjust back tension as 30 ~ 35 g-cm by the TENSION HOLDER position.

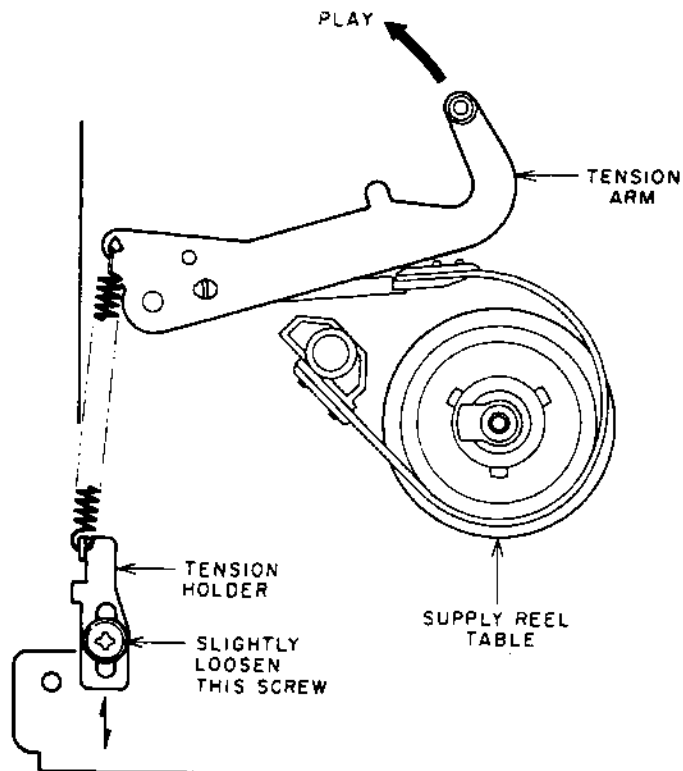

Fig. 6-2

6-2. LOADING LEADER HEIGHT ADJUSTMENT

- 1) Slightly loosen the set screw at the lower part of the LOADING LEADER so that the LOADING LEADER can be adjusted with reasonable tightness. Adjust the coarse height of the LOADING LEADER from the base mount as 0.6 to 0.8 mm.
- 2) Set the reference tape TF-530RFS (AT-751775) and depress the PLAY button.
- 3) Connect an oscilloscope to TP1 (RF ENVELOPE) on the MAIN PC BOARD, and turn the LOADING LEADER height adjustment screw heads to obtain the flat envelope as Fig. 6-5 ideal envelope. After the adjustments, tighten the LOADING LEADER set screw.

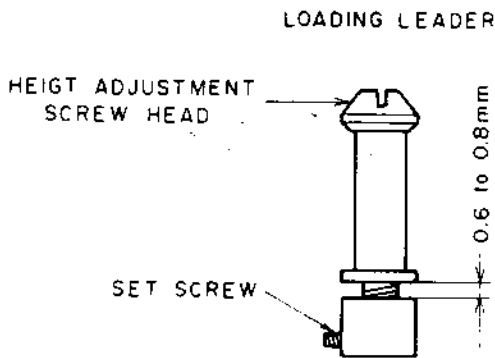

Fig. 6-3

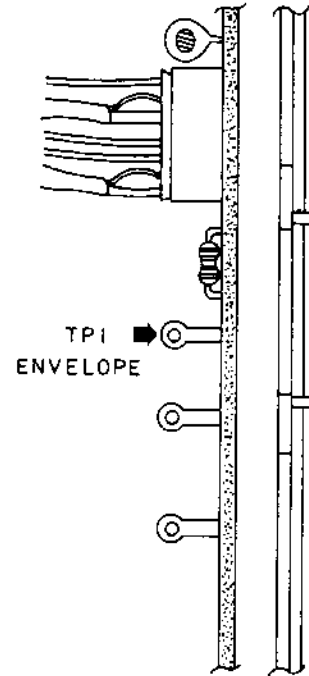

Fig. 6-4 MAIN (VIDEO) PCB.

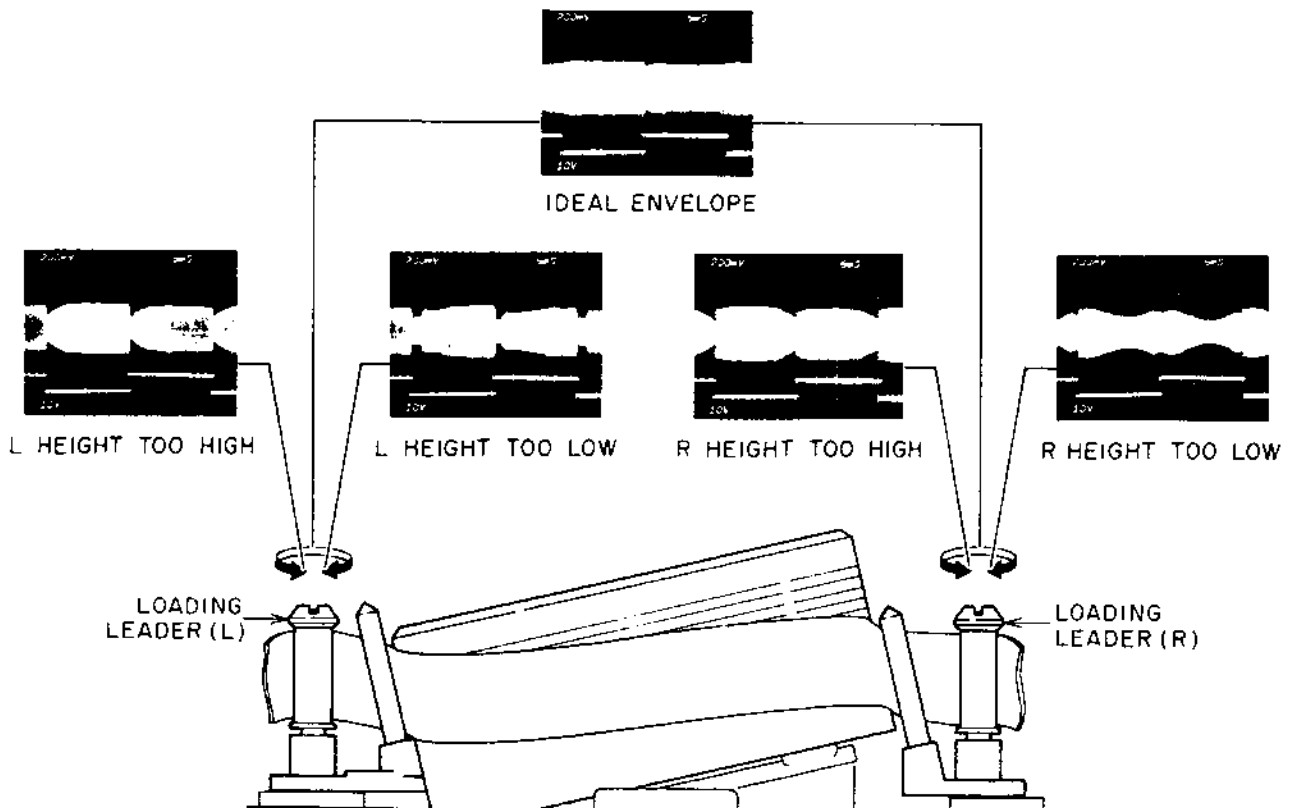

Fig. 6-5

6-3. TAPE CURL AT TAKE-UP TAPE GUIDE ADJUSTMENT

Turn the screw (a) on the A/C HEAD BLK so that the down edge of the tape touches the TAKE-UP TAPE GUIDE lower part without any curl or waving.

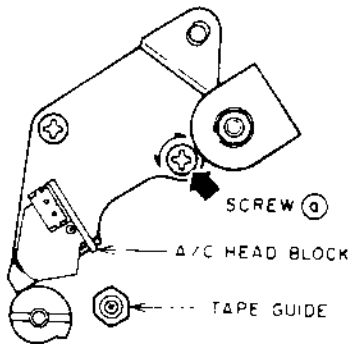

Fig. 6-6

- 2) Connect an oscilloscope or AC voltmeter to the AUDIO LINE OUT.
- 3) Set the reference tape TF-530RFS (AT-751775) and depress the PLAY button.
- 4) Turn the screw (b) to obtain the maximum audio signal output.

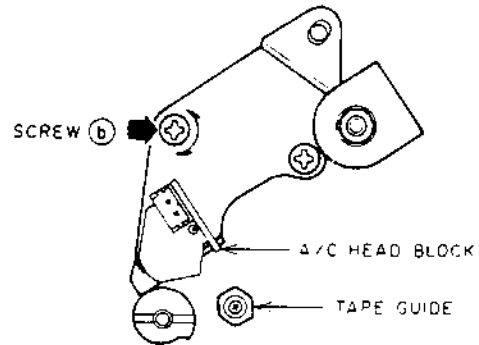

Fig. 6-10

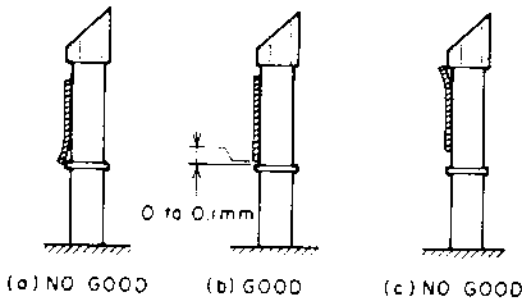

Fig. 6-7

6-5. RF ENVELOPE ADJUSTMENT

- 1) Set the reference tape TF-530RFS (AT-751775) and depress the PLAY button.
- 2) Slightly turn the LOADING LEADER HEIGHT ADJUSTMENT SCREW HEAD (L) (R) to obtain the IDEAL ENVELOPE as shown in Fig. 6-5.

6-4. AUDIO HEAD AZIMUTH ADJUSTMENT

- 1) Turn the NUT (a) for coarse A/C HEAD BLOCK height adjustment as in Fig. 6-7, 8.

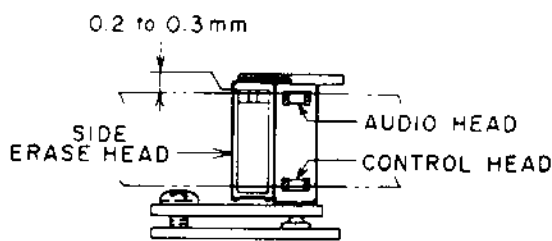

Fig. 6-8

6-6. TAPE CURL AT SUPPLY TAPE GUIDE ADJUSTMENT

- 1) Check the tape curl at Supply Tape Guide slightly turn the NUT (a) if the tape curl exists.

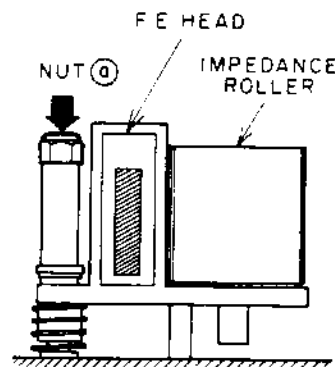

Fig. 6-11

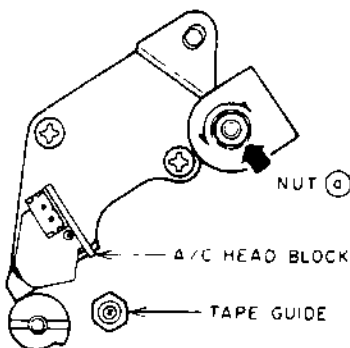

Fig. 6-9

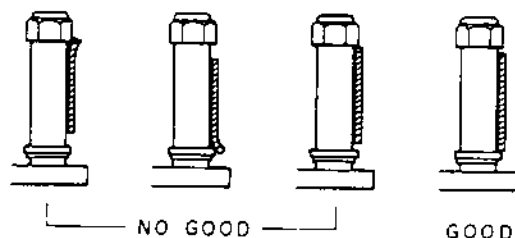

Fig. 6-12

6-7. AUDIO HEAD HEIGHT ADJUSTMENT

- 1) Connect an oscilloscope or a AC Voltmeter to the LINE AUDIO OUT.
- 2) Set the reference tape TF-530RFS (AT-751775) and depress the PLAY button.
- 3) Slightly turn the NUT (a) shown in Fig. 6-9 to obtain the maximum audio output.

6-8. CONTROL HEAD POSITION ADJUSTMENT

- 1) Connect an oscilloscope to TP1 RF ENVELOPE test terminal on the MAIN (VIDEO) PC Board.
- 2) Set the reference tape TF-530RFS (AT-751775) and depress the PLAY button.
- 3) Set the Tracking Control Volume to center click position.
- 4) Adjust Mechanical Tracking Adjustment Screw (a) to obtain the maximum RF ENVELOPE.

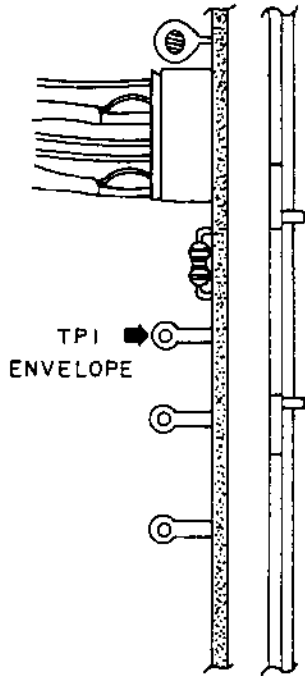

Fig. 6-13

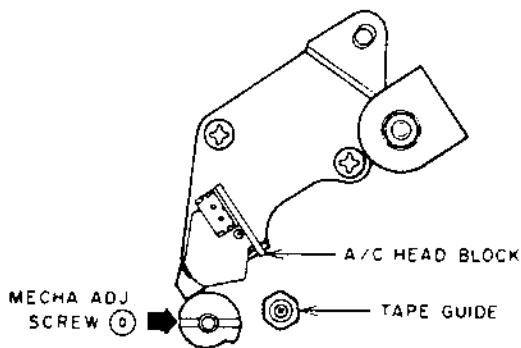

Fig. 6-14

6-9. CUE REVIEW ADJUSTMENT

- 1) Set a E-180 tape, press the PLAY and the F.FWD button (CUE mode).
- 2) Turn the CUE/REVIEW GUIDE height adjustment Nut (c) so that the wrinkle between the PINCH ROLLER and the CUE/REVIEW GUIDE are not existed.
- 3) Depress the REV button (REVIEW mode) confirm the curl at the tape down edge is not existed at the TAPE GUIDE as shown in Fig. 6-7. Fig. 6-7 (c) is not acceptable, but Fig. 6-7 (b) is acceptable).

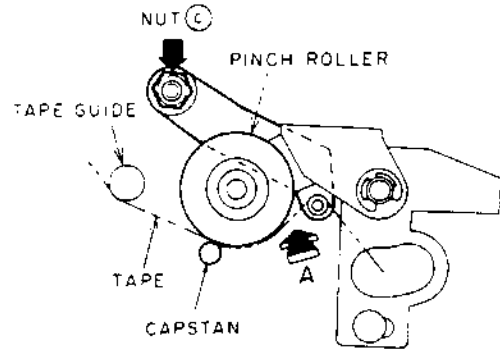

Fig. 6-15

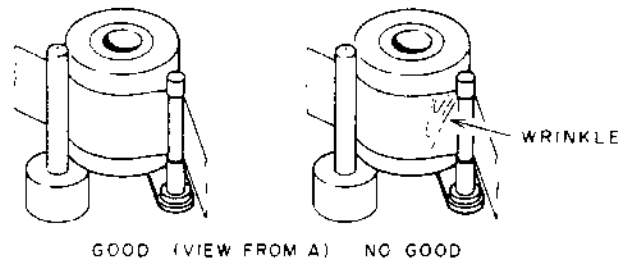

Fig. 6-16

VII. HEAD DRUM REPLACEMENT

7-1. REPLACEMENT PROCEDURE

- 1) Remove the Drum Earth Brush.
- 2) Unsolder the four wires from the Rotary Trans, BLUE and BROWN for CH1, BLUE and RED for CH2.
- 3) Remove the Upper Drum Fixing Screw.
- 4) Install the Upper Drum. (Head Drum)
- 5) Tighten the Upper Drum Fixing Screws.
- 6) Resolder the four wires from the Rotary trans.

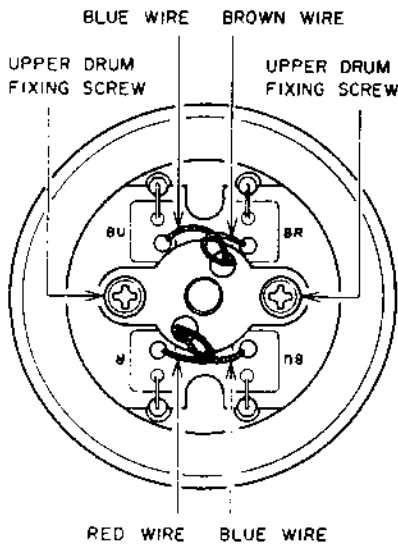

Fig. 7-1

7-2. AFTER REPLACEMENT

After replacement, the following adjustments and confirmations are necessary for the proper performance.

- 1) Tracking preset adjustment. (Servo adjustment Step 2)
- 2) PB switching point adjustment. (Servo adjustment Step 3)
- 3) REC current adjustment. (Video adjustment Step 1)

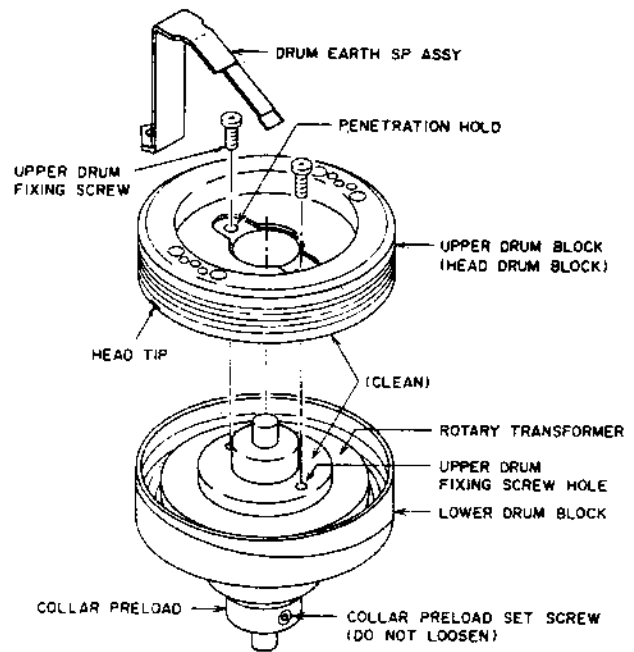

Fig. 7-2

NOTE: Height precision is required for the proper performance, and the head tips are fragile, so the following points should be noted when replacing the upper drum block.

- (a) Do not loosen the set screw on the collar preload.
- (b) Before fixing, clean both surfaces where the upper drum and the rotary transformer part meet with alcohol.
- (c) When installation of upper drum, if it does not go on to the shaft easily, clean the hole in the upper drum with alcohol and put a little oil on the shaft.
- (d) Make sure that the upper drum fixing screw holes on the rotary transformer part and the upper drum fixing screw penetration holes match exactly before inserting the fixing screws.
- (e) Tighten the two upper drum fixing screws alternately and gradually. Tighten them at 6 kg-cm torque.

VIII. HOW TO MOUNT THE ROTARY PLATE

When mounting the rotary plate on the drum motor, be sure to align the mark (Small round hole) on the rotary plate (a) with the collar preload set screw (d) on the collar preload (c) as illustrated above.

NOTE: Do not attempt to remove the collar preload (c) on the head assy. If removed, a special jig is needed for reinstallation, which almost always requires replacement of the drum assy.

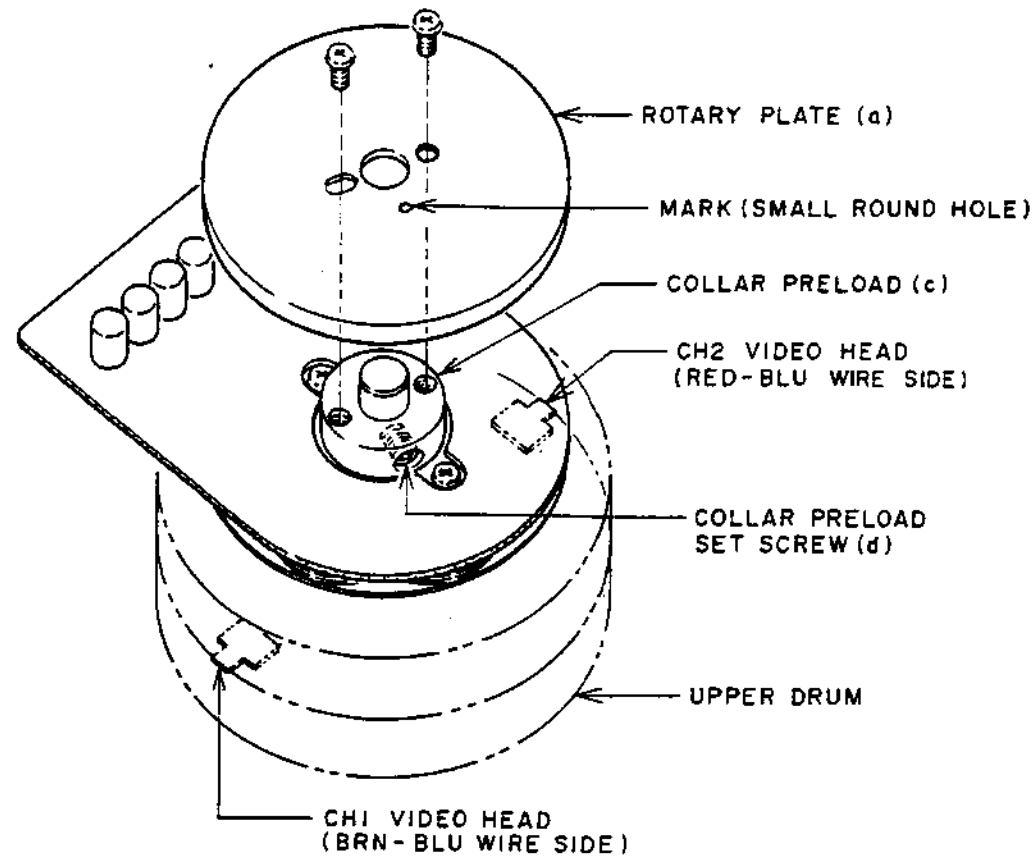

Fig. 8-1 How to Mount the Rotary Plate

IX. HOW TO ASSEMBLE LOADING MECHANISM

1) With the unit unloaded, attach Gear Loading (S) BLK and Gear Loading (T) BLK to Mecha chassis so that align the mark.

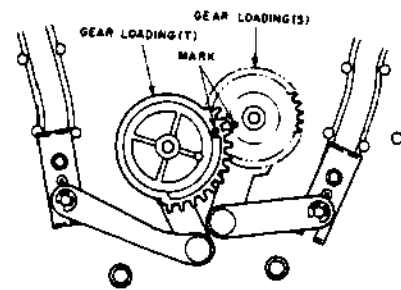

Fig. 9-1

2) Attach Gear Cam Eject to Mecha chassis so that align the marks.

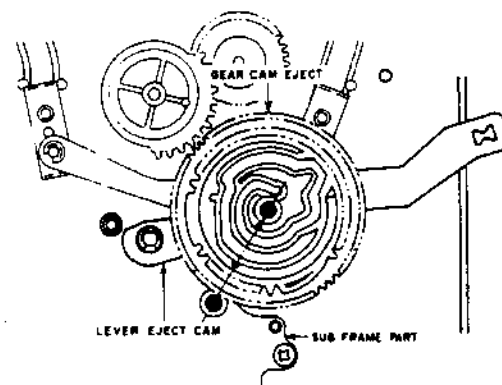

Fig. 9-2

3) Attach Gear Cam Main to Mecha chassis so that Pin (A) of Lever P Cam and Pin (B) of Lever Cam Slide mate oval hole of Gear Cam Main.

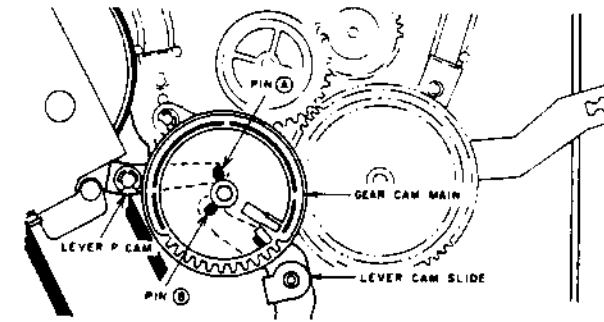

Fig. 9-3

4) Attach Lever Cam Tension to Mecha chassis so that Pin (A) goes into valley of Gear Cam Eject.

5) Attach Lever Cam F/R to Mecha chassis so that Pin (B) goes into valley of Gear Cam Eject, and Pin (C) of Plate F/R Slide (2) Part into hole of lever Cam F/R.

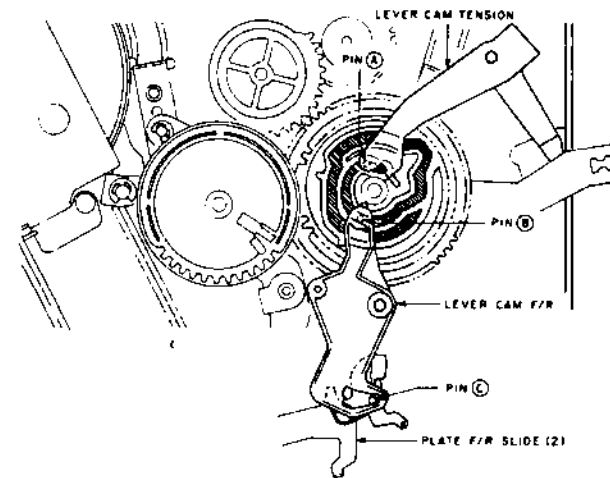

Fig. 9-4

6) Attach Arm Set Free onto Lever Cam Slide.

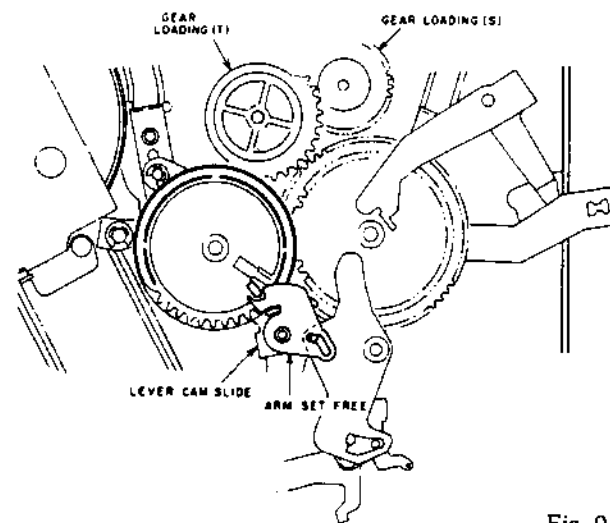

Fig. 9-5

7) Attach Mode SW BLK to Mecha chassis so that the latch of Rotary Encoder goes into slit (A) of Gear Cam Main and tighten with screw (B).

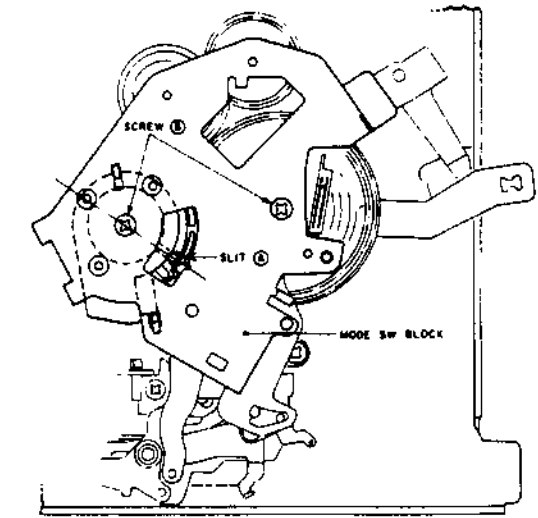

Fig. 9-6

8) Mount Loading Motor BLK and tighten with screw (A).

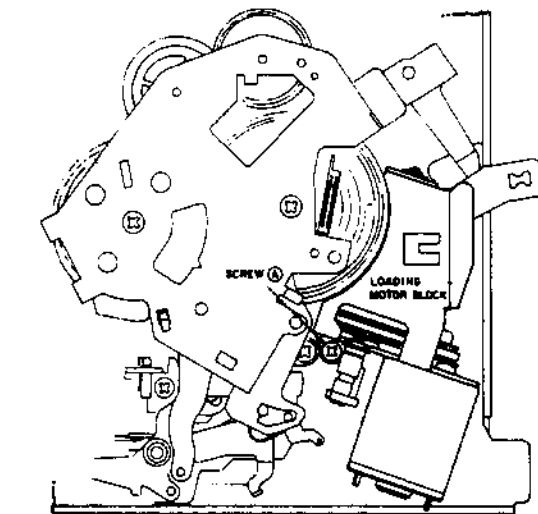

Fig. 9-7

X. ELECTRICAL ADJUSTMENT

10-1. MAIN PCB ADJUSTMENTS

Precautionary items prior to adjustments

1. The color bar generator output should be 1.0 Vp-p.
2. Video output terminal should be terminated with 75 ohms (dummy or load).

Required following Test tapes.

Test Tape	Part No.
TF-530RFS	AT-751775
TF-527BL	AT-711880

STEP	ADJUSTMENT ITEM
1.	MODE and INPUT SIGNAL/TEST TAPE
2.	TEST POINT and ADJ. part
3.	RESULT & REMARKS

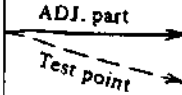

IMS POSITION

1. "E-E (Stop mode)
2. TV screen & VC951
3.
 - Depress the PROGRAM button on the REMOTE CONTROL unit.
 - Adjust VC951 so that characters located center of the TV screen.

CHARACTOR POSITION

OPERATION(B) PCB

AUDIO ADJUSTMENT

3 AUDIO AZIMUTH

1. "PB" Test tape TF-530RFS.
2. AUDIO OUT.
3. Confirm $-6 \sim -14$ dBm. (TF-508RF: $-5 \sim -11$ dBm)

1 AUDIO PB LEVEL

1. "PB" Test tape TF-527BL.
2. Audio out & VR501.
3. -3.0 ± 0.5 dBm (TF-513L: -9.0 ± 0.5 dBm)

2 REC CURRENT

1. "REC" (1 kHz, -8 dBm)
2. Test terminal on the A/C Head & VR502.
3. 2.9 ± 0.1 mV

SERVO ADJUSTMENT

3 PB SWITCHING POINT

1. "PB" Test tape TF-530RFS.
2. TP-Video out, P204 pin 1 (SW. P) for trigger signal & VR201.
3. Adjust "T" to 6.5 ± 0.5 H

2 TRACKING PRESET

1. "PB" Test tape TF-530RFS.
2. Test terminal P204 pin 2 (CTL), pin 3 (V-SYNC) & VR202.
3.
 - Set the TRACKING Control to center click position.
 - Adjust VR202 so that the phase at raising part of CTL pulse and V-SYNC pulse are lined up.

1 IDL 5V

1. "E-E" (stop mode)
2. TP4 (IDL 5V) & VR301
3. 5.1 ± 0.05 V

4 VERTICAL STABILITY

1. "REC" TV program and PB/PAUSE
2. TV screen & VR401
3. Minimum vibration of still picture.

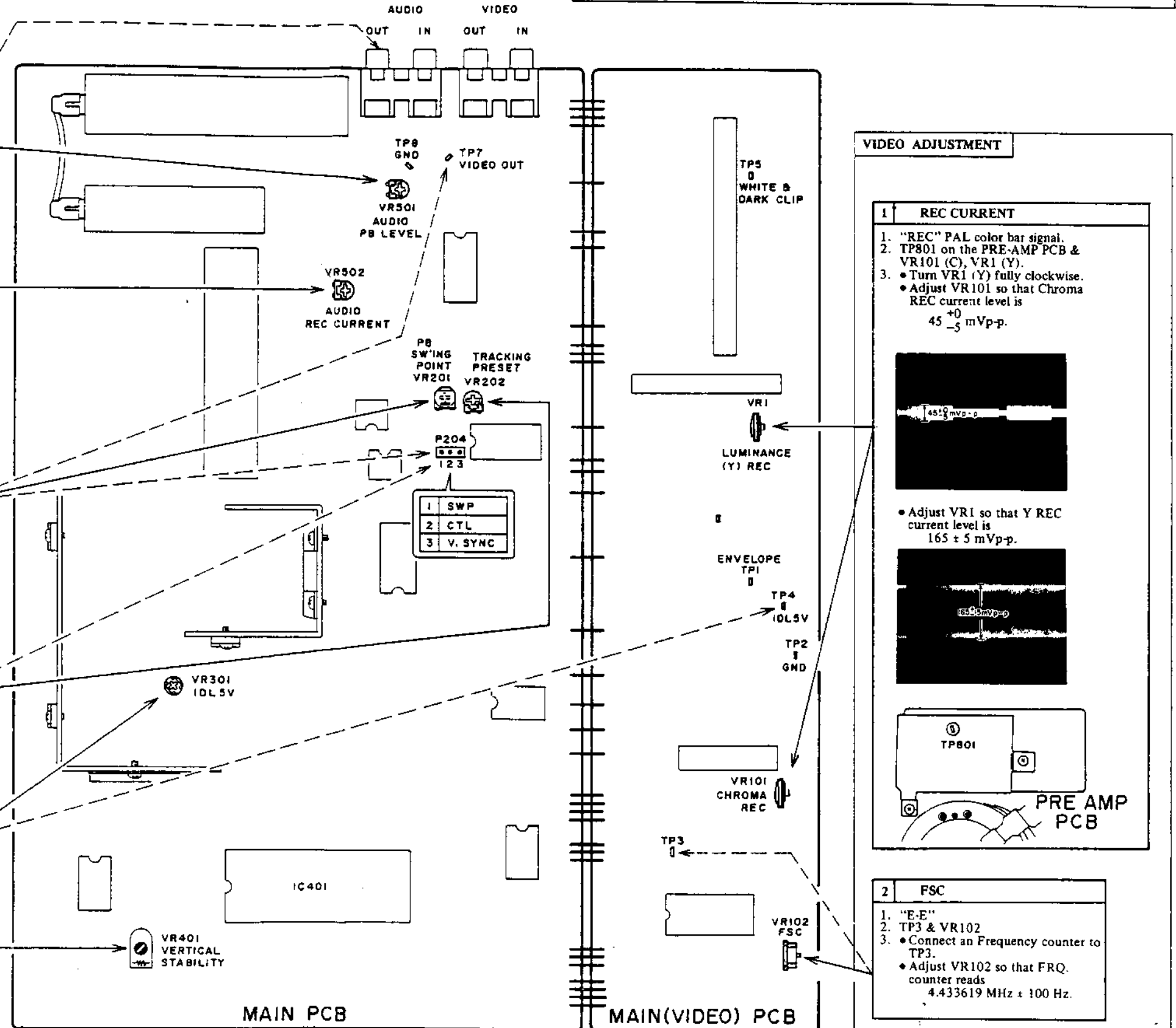

VIDEO ADJUSTMENT

1 REC CURRENT

1. "REC" PAL color bar signal.
2. TP801 on the PRE-AMP PCB & VR101 (C), VR1 (Y).
3.
 - Turn VR1 (Y) fully clockwise.
 - Adjust VR101 so that Chroma REC current level is 45_{-5}^{+0} mVp-p.

• Adjust VR1 so that Y REC current level is 165 ± 5 mVp-p.

2 FSC

1. "E-E"
2. TP3 & VR102
3.
 - Connect an Frequency counter to TP3.
 - Adjust VR102 so that FRQ. counter reads 4.433619 MHz ± 100 Hz.

10-2: LUMINANCE SIGNAL PROCESSING IC (EHM-M96A8U63K) ADJUSTMENTS

NOTE: These adjustment's are generally unnecessary, except when replacing this IC.

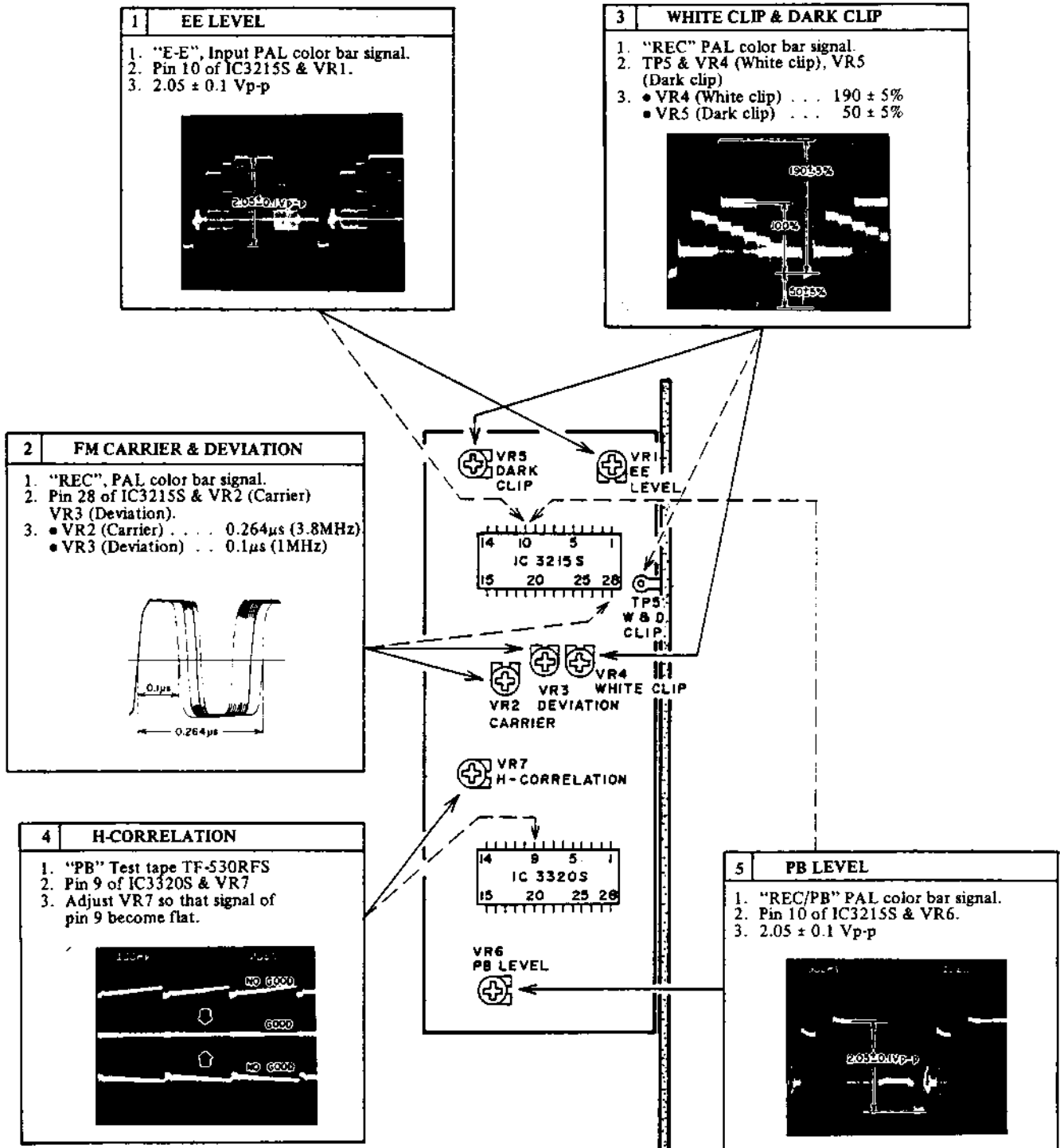

XI. PARTS LIST

ATTENTION

1. When placing an order for parts, be sure to list Part No., Model No. and the description of each part. Otherwise, the non-delivery of the part or the delivery of a wrong part may result.
2. Please make sure that Part No. is correct when ordering.
If not, a part different from the one you ordered may be delivered.
3. Since the parts shown in Parts List of Preliminary Service Manual may have been the subject of changes, please use this Parts List for all future reference.

HOW TO USE THIS PARTS LIST

1. This Parts List lists those parts which are considered necessary for repairs. Other common parts, such as resistors and capacitors, are listed in the "Common List for Service Parts" from which these parts should be selected and stocked.
2. The Recommended Spare Parts List shows those parts in the Parts List which are considered particularly important for service.
3. Parts not shown in the Parts List and "Common List for Service Parts" will not in principle be supplied.
4. How to read the Parts List.

a) Mechanism Block

b) PC Board

2. HEAD BASE BLOCK

REF. NO.	PART NO.	DESCRIPTION
2-1x	BH-T2023A320A	HEAD BASE BLOCK
2-2	HP-H2206A010A	HEAD R/P PR4-8FU C
2-3	ZS-477876	PAN20x03STL CMT
2-4	ZS-536488	BID20x08STL CMT
2-5	ZG-402895	SP CS ANGLE ADJUST

SP (Service Parts) Classification

A small "x" indicates that this part is not shown in the Photo or Illustration.

This number corresponds with the individual parts index number in that figure.

This number corresponds with the Figure Number.

6. MAIN PC BOARD

REF. NO.	PART NO.	DESCRIPTION
6-IC1	EI-324536	IC HD14049BP
6-IC2	EI-336801	IC MB8841-564M
6-C1A	EC-338399	C MMY V 223M 250AC [U,E,B,S]
6-C1B	EC-350949	C MMY V 223M 250DC [J]
6-C1C	EC-338397	C MMY V 223M 125AC [C,A]
6-X1	EI-318384	OSC X'TAL NC-18C

Symbols for primary destination

[A]: AAL(U.S.A.) [S]: SAA(Australia)
 [B]: BEAB(England) [U]: U/T(Universal Area)
 [C]: CSA(Canada) [V]: VDE(W. Germany)
 [E]: CEE(Europe) [Y]: Custom Version
 [J]: JPN(Japan)

SP (Service Parts) Classification

These reference symbols correspond with component symbols in the Schematic Diagrams.

The available PC Board Blocks are listed separately.

5. When Part No. is known, Parts Index at end of Parts List can be used to locate where that part is shown in Parts List by its Reference No. listed at right of Part No.

WARNING

△ (*) INDICATES SAFETY CRITICAL COMPONENTS. FOR CONTINUED SAFETY, REPLACE SAFETY CRITICAL COMPONENTS ONLY WITH MANUFACTURE'S RECOMMENDED PARTS.

AVERTISSEMENT

△ (*) IL INDIQUE LES COMPOSANTS CRITIQUES DE SÉCURITÉ. POUR MAINTENIR LE DEGRÉ DE SÉCURITÉ DE L'APPAREIL, NE REMPLACER QUE DES PIÈCES RECOMMANDÉES PAR LE FABRICANT.

2. HEAD DRUM BLOCK

Ref. No.	Part No.	Description
2-1	BV-V1030A210F	LOWER DRUM BLK VS-240EG
2-2	ZS-354332	PAN26X08STL CMT SW
2-3	BV-V1030A220D	UPPER DRUM BLK VS-303EG
2-4	ZS-362241	BID30X08STL CMT
2-5	ZS-432843	PAN26X04STL CMT
2-TH901	EX-361672	DEW SENSOR (HEATER) MRX
2-6	BM-M3224A020A	PC MOTOR BLK SM-24D
2-7	BV-8362443B	YOKE MAGNET (3) PART
2-8	ZS-356536	PAN26X06BRS N3
2-9	VT-361452	DRUM EARTH SP ASSY(A)
2-10	ZS-421806	PAN30X08STL CMT

NOTE: The parts reference numbered here except the ones in 500's are normally stocked for replacement purpose. The rest of the parts shown in this manual are not stocked since they are seldom required for routine service.

HEAD DRUM BLOCK

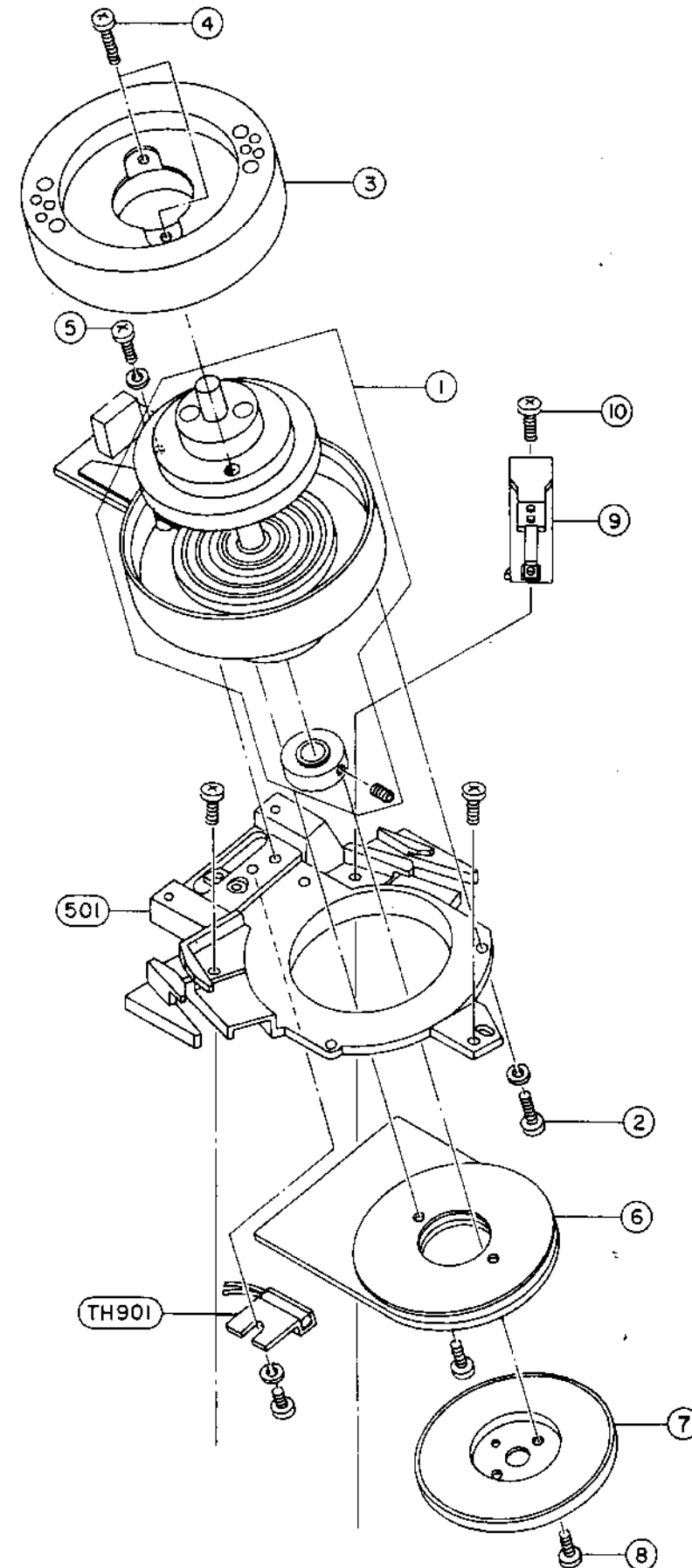

CHASSIS MECHA BLOCK (1)

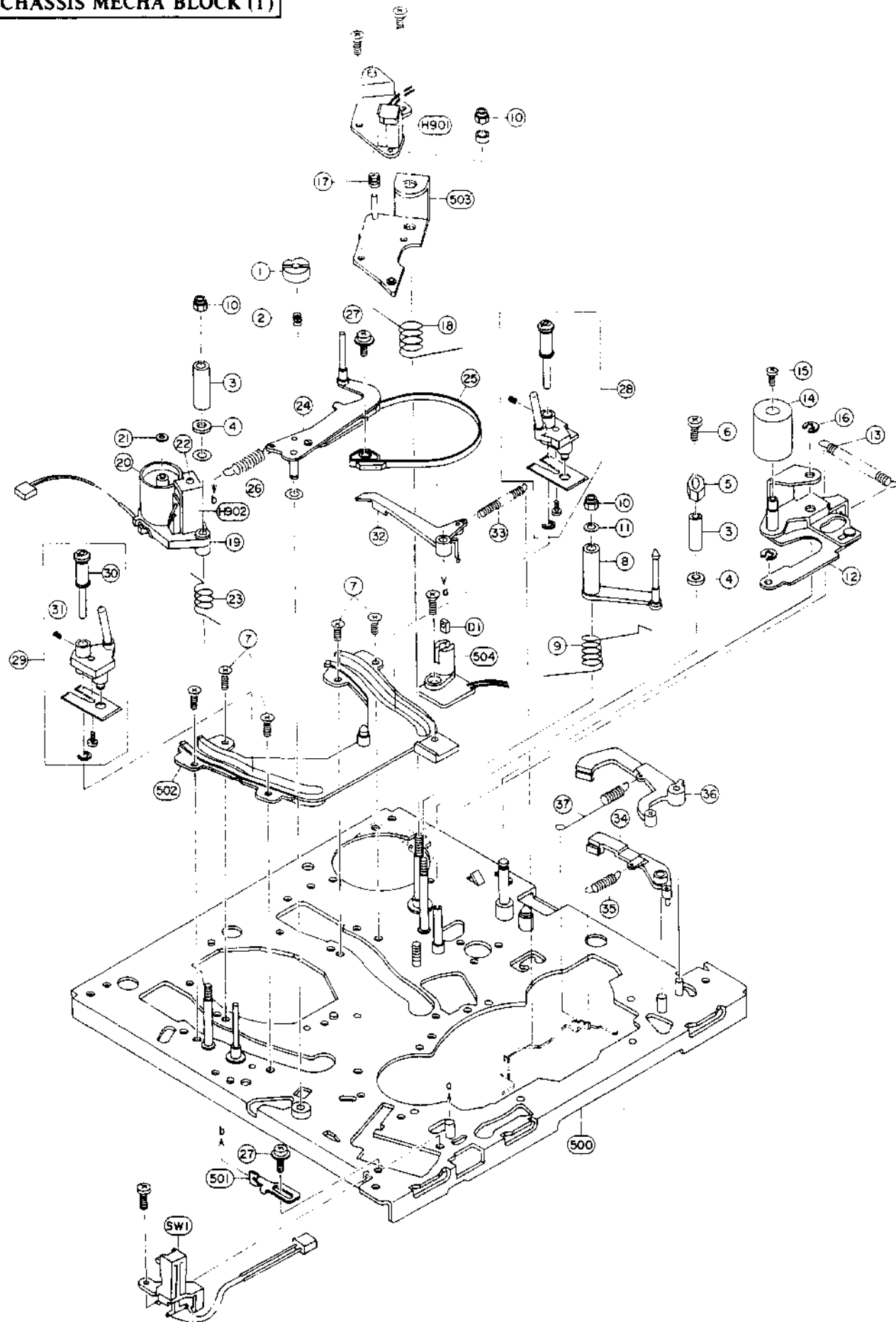

3. CHASSIS MECHA BLOCK (1)

Ref. No.	Part No.	Description
3-1	ZS-360372-A	SCREW ADJUST
3-2	ZG-363349	SP PUSH ADJUST SCREW
3-3	MS-372186	GUIDE TAPE (6)
3-4	MS-370840-A	GUIDE TAPE (5)
3-5	MS-362181	GUIDE TAPE TU
3-6	ZS-608095	PAN20X05STL CMT
3-7	ZS-360391	SCREW SPECIAL
3-8	BL-B360353	LEVER REVIEW PART
3-9	ZG-360805	SP TORSION REVIEW ARM
3-10	ZW-350839	N30 NYLON
3-11	ZW-324417	PW31X060X05OPSL
3-12	BL-B360361-B	ARM PINCH ROLLER PART
3-13	ZG-360602	SP PULL PINCH
3-14	MP-361543-B	PINCH ROLLER PART
3-15	ZS-477876	PAN20X03STL CMT
3-16	ZW-270101	RING E 300SUP CMT
3-17	ZG-313258	SP C-03.5/0.80-10.0 C-102
3-18	ZG-360803	SP TORSION A/C HEAD
3-19	MZ-B362281	HOLDER FE HEAD (2) PART
3-20	MR-364335	ROLLER MPEDANCE
3-21	ZW-361458	PUSH WASHER 18X032X025PSL
3-22	ZS-460440	PAN20X04STL CMT
3-23	ZG-360804	SP TORSION HOLDER FE HEAD
3-24	BL-B360342-A	LEVER TENSION PART
3-25	BL-B360350	ARM TENSION BAND PART
3-26	ZG-321731	SP T2-04.0/0.40-25.0 T2-115
3-27	ZS-200614	SCREW TRIPLE PAN30X08
3-28	BV-V1047A080A	LOADING LEADER(R) BLK VS-112EG
3-29	BV-V1047A090A	LOADING LEADER(L) BLK VS-112EG
3-30	VT-360148-B	VERTICAL POLE PART
3-31	ZS-321729	6SET20X040SCM PKR WP
3-32	BL-B360486	LEVER FF BRAKE PART
3-33	ZG-364338-A	SP PULL FF BRAKE
3-34	ML-B364686-A	LEVER SUB BRAKE(R-2)PART
3-35	ZG-364339	SP PULL REW BRAKE
3-36	ML-B364685	LEVER BRAKE REVIEW(2) PART
3-37	ZG-364337	SP PULL REVIEW BRAKE
3-D1	ED-357540	D LED LN59
3-H901	HR-361454	HEAD COMBO HVMLA1004C
3-H902	HE-361456	HEAD E HVFMD0005B
3-SW1	ES-360433	SW LEAF MRX

NOTE: The parts reference numbered here except the ones in 500's are normally stocked for replacement purpose. The rest of the parts shown in this manual are not stocked since they are seldom required for routine service.

4. CHASSIS MECHA BLOCK (2)

Ref. No.	Part No.	Description
4-1	MZ-8360528	HOLDER CAPSTAN PART
4-2	ZS-379350	PAN30X08STL CMT
4-3	MZ-360384	GEAR LOADING (S)
4-4	ZG-360801-A	SP PULL LOADING
4-5	MZ-360385-A	GEAR LOADING (T)
4-6	ZW-357164	RING E 230SUP GMT
4-7	ZW-270101	RING E 300SUP CMT
4-8	ML-366738	PLATE MAIN SLIDE(2)
4-9	MZ-8366734	PLATE F/R SLIDE (2)PART
4-10	ZG-358276	SP T8-03.2/0.20-12.5 T8-041
4-11	ZG-350891	SP T2-04.0/0.40-22.4 T2-114
4-12	ZG-360438	SP TORSION LIFTER
4-13	MB-366733	STOPPER SLIDE (2)
4-14	ML-8364884	ARM(TU) MAIN BRAKE(2) PART
4-15	ML-8364883	ARM(S) MAIN BRAKE(2) PART
4-16	ZG-366617	SP PULL MAIN BRAKE
4-17	ZW-360541	WASHER POLY SLIDER(3)
4-18	MZ-8360425-B	SUB FRAME PART
4-19	BR-8365715-B	TAKE-UP REEL TABLE PART 2
4-20	BR-8365718-B	SUPPLY REEL TABLE PART 2
4-21	MZ-366960	GEAR TU BLK (2)
4-22	ML-8360460-B	LEVER CAM SLIDE PART
4-23	ZW-410051	RETAINING RING E250SUP CMT
4-24	MZ-364877	GEAR CAM EJECT(2)
4-25	MZ-364876	GEAR CAM MAIN(2)
4-26	ML-8366735	LEVER CAM TENSION(2) PART
4-27	ML-366736	ARM SET FREE(2)
4-28	MZ-360477-B	PLATE MODE SW
4-29	VT-372187	ROTARY ENCODER D2ZQ-R9-1
4-30	BF-8360531-B	FLYWHEEL CAPSTAN PART
4-31	ZW-360539	STOPPER OIL
4-32	ML-8366815-A	LEVER CAM F/R PART
4-33	ZS-379350	PAN30X08STL CMT
4-34	MB-360534	BELT IDLER
4-35	MB-360533	BELT PAL
4-36	MZ-360453	WORM GEAR
4-37	MR-384010	PULLEY WORM
4-38	ZW-360479-A	WASHER THRUST WORM
4-39	ZG-360441	SP TORSION ONE WAY
4-40	MZ-360440-A	HOLDER PULLEY WORM
4-41	MR-360432	PULLEY TRIGGER
4-42	ZW-361458	PUSH WASHER 18X032X025PSL
4-43	ZW-356657	RING E150SUP CMT
4-44	MB-364011	BELT SYNC NB930N15-020T
4-M902	BM-361544-B	MOTOR FG KCX-38F5B
4-M903	BM-8361467	LOADING MOTOR PART
4-SW2	ES-361479	SW LEAF MSW-1594C
4-PH1	ET-361463	DETECTOR ON2170 Q,R

NOTE: The parts reference numbered here except the ones in 500's are normally stocked for replacement purpose. The rest of the parts shown in this manual are not stocked since they are seldom required for routine service.

CHASSIS MECHA BLOCK (2)

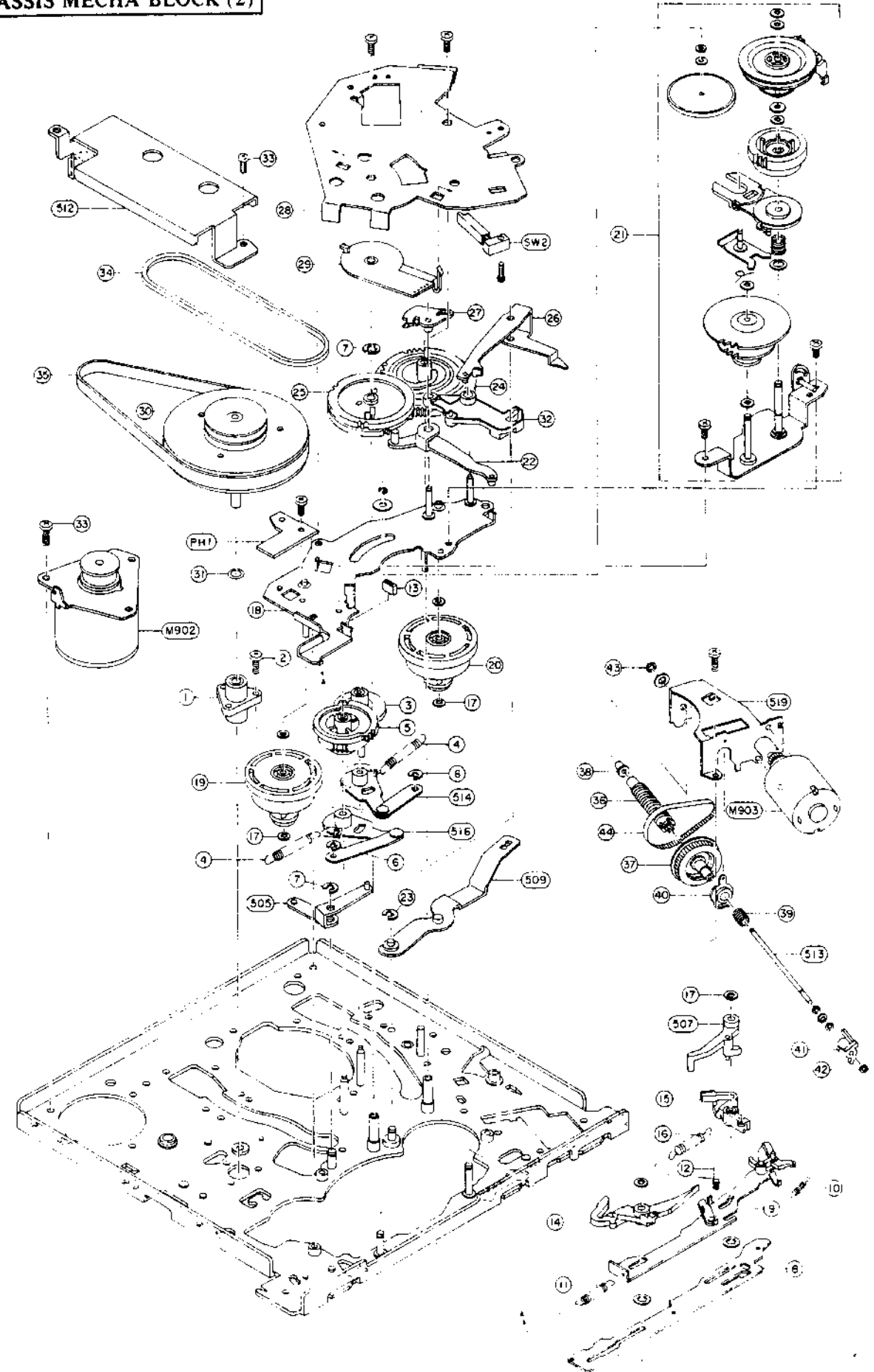

EJECTOR BLOCK

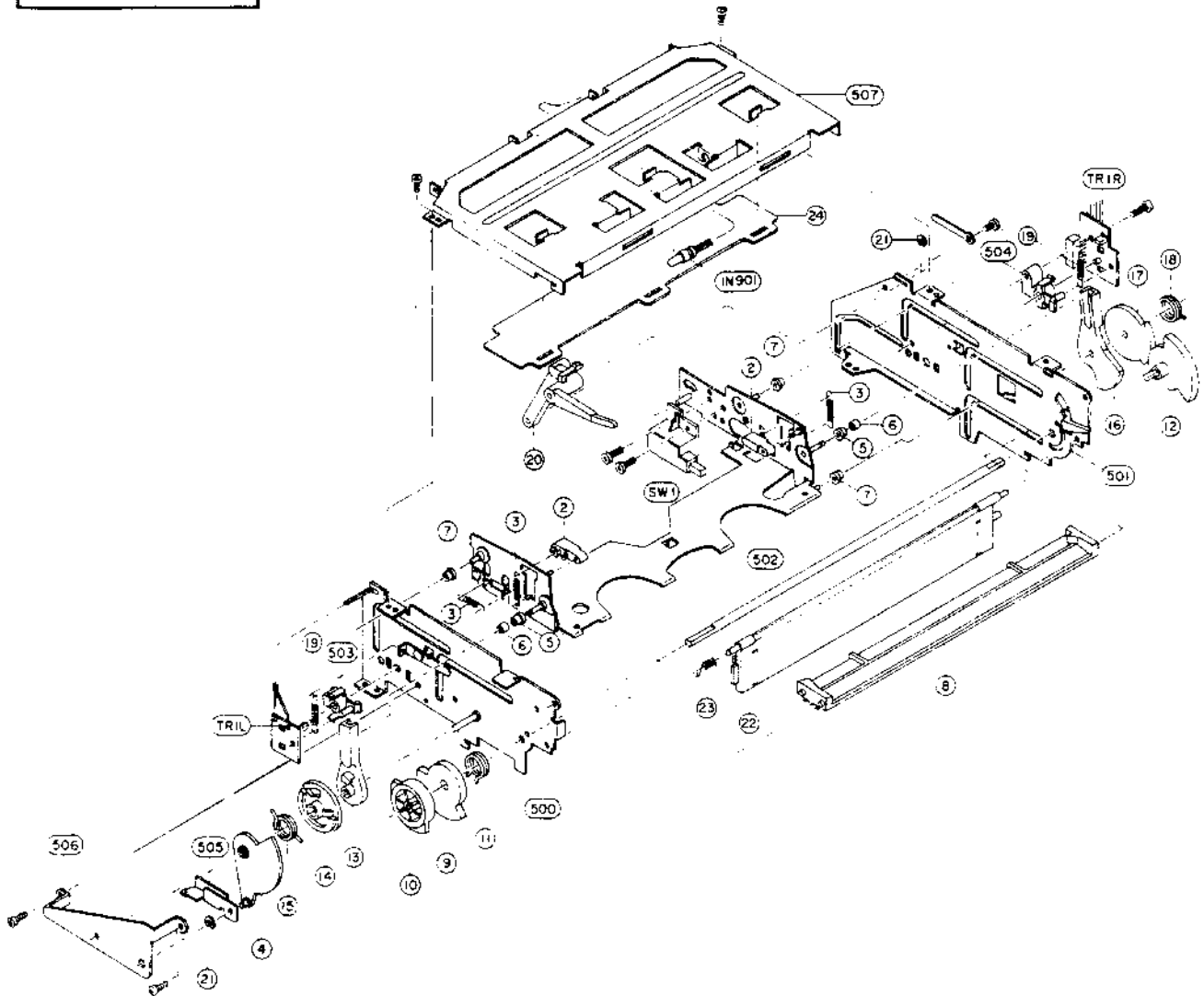

5. EJECTOR BLOCK

Ref. No.	Part No.	Description
5-1	BV-V1047A250E	EJECTOR BLK VS-240
5-2	ML-361316	ARM PRESSING
5-3	ZG-357865	SP T5-04.0/0.40-11.2 T5-108
5-4	MZ-8360642	GEAR EJECT PART
5-5	MR-361310	ROLLER (1)
5-6	MR-361311	ROLLER (2)
5-7	MR-361312	ROLLER (3)
5-8	SZ-360607	GUIDE
5-9	MZ-361314-A	GEAR (1)
5-10	MZ-361313	GEAR (3)
5-11	ZG-360615	SP TORSION (EJ)
5-12	MZ-360640-A	GEAR (2)
5-13	ML-360635	ARM LOADING (L)
5-14	MZ-360639	GEAR (4)
5-15	ZG-360614	SP TORSION (L)
5-16	ML-360634	ARM LOADING (R)
5-17	MZ-360638	GEAR (5)
5-18	ZG-360613	SP TORSION (R)
5-19	ZG-358212	SP T5-06.3/0.50-16.0 T5-180

Ref. No.	Part No.	Description
5-20	BL-8361308	ARM LID OPENER PART
5-21	ZW-357164	RING E 230SUP CMT
5-IN901	EL-367397	PL CORD 14.0V BOMA 250/250
5-IN902	EL-367396	PL CORD 14.0V BOMA 190/190
5-SW1	ES-353622-A	SW PUSH EVQ-WU7001 02-2
5-TR1L	ET-361490	TR PHOTO PN268 R.S
5-TR1R	ET-361490	TR PHOTO PN268 R.S
5-22	SE-361317R-A	MASK CASSETTE HQ
5-23	ZG-360616	SP TORSION
5-24	SP-364666	PLATE MIRROR (2)

NOTE: The parts reference numbered here except the ones in 500's are normally stocked for replacement purpose. The rest of the parts shown in this manual are not stocked since they are seldom required for routine service.

ABBREVIATIONS (VIDEO)

ABBREVIATION	EXPLANATION	ABBREVIATION	EXPLANATION
AC	Alternating Current	LM STP	Loading Motor STOp
ACC	Auto Color Control	LP	Long Play
A/C	Audio and Control	LPF	Low Pass Filter
ADJ	ADJust(ment)	LSW	Loading SWitch
AFC	Auto Frequency Control	ME-SECAM	Middle East SECAM
AFT	Auto Fine Tuning	MI-COM	Micro COMputer
AGC	Auto Gain Control	MM	Mono-stayble Multi
AH(P)	Audio Head (Play Back)	MRS	Motor ReverSe
AH(R)	Audio Head (Record)	NG	Noise Gate
AL	ALl	NON-LIN	NON-LINear
AL	ALways	N.T.S.C.	National Television System Committee
ALC	Auto Level Control	O MUTE	Output MUTE
A-SW P	Audio-SWitching Pulse	OSC	OSCillator
A-MUTE	Audio-MUTE	PAL	Phase Alternation Line
AUT/MAN	AUTO/MANual	PB	Play Back
ANT	ANTenna	P-COM	Phase-COMparator
APC	Automatic Phase Control	PDN	Power Down
ASSY	ASSEMBLY	PG	Pulse Generator
BAL	BA Lance	PL, PLG	PLunger (PLunGer)
B/C	Buzz and Charactor	POS	POStion
B DOWN	Break DOWN	PRG	PRoGram
BGP	Burst Gate Pulse	P & S	Power supply & System control
BLK	BLack or BLock	PU	Pick Up (head, pulse)
BM	Balanced Modulator	PWR	POWeR
BPF	Band Pass Filter	Q	Quality factor
BS	Band Select	RC	Rotary Control
BS (SB)	Brake Supply (Supply Brake)	REC	RECOrd
BT (TB)	Brake Takeup (Takeup Brake)	REF	REFErence
BU	Back Up	REF-V	REFErence Vertical signal
B/W	Black and White	REG	REGulator
CCIR	Comité Consultatif International des Radio Communications	REV (REVW)	REView (REView)
CH (Ch.)	CHannel (Channel)	REW	REWind
CK	Color Killer	RFB	Radio Frequency Booster
CLK	CLock	RM	Reel Motor
CLP	CLIP	RM PWR	Reel Motor POWeR
CM	Capstan Motor	R-S SW	Record Safety SWitch
CN	CoNnector	RST (RES)	ReSeT (RESet)
COMP	COMParator	RVS	ReVerSe
Comp	Comparison	S	Sensor, Shield
C or R	Cue or Review	SC	SimulCast
CR I	Cue Review I (high)	S CLK	Serial CLock
CSW	Cassette SWitch	S & A	Servo & Audio
CTL	ConTrol	SECAM	Séquentiel à Memoire
CUE	CUE	SEP (SEPA)	SEPARator (SEPARator)
CW	Carrier Wave	SFP	Sync Front Pulse
DAC	Digital to Analog Converter	S & H	Sample and Hold
DC	Direct Current	SLP	Super Long Play
DEMOD	DEMODulator	SP	Standard Play
DET	DETECT (DETECTOR)	SPD	SPeed
DL	Delay Line	SRP	Supply Reel Pulse
DM	Drum Motor	SRV	SeRVo
DOC	Drop Out Compensator	SOW	Sync On Word
D-P-E	Drum-Phase-Error	STBY	STandBY
D-PG	Drum-Pulse Generator	SW	SWitch
D-TPZ	Drum-TraPeZoid	SW'NG	SWitchING
EE	Electronic to Electronic	SWP	SWitching Pulse
EF	Emitter Follower	SYNC	SYNChronize
EM	Eject Motor	T-AUDIO	Tuner AUDIO
EMPHA	EMPHASIS	TA-MUTE	Tuner Audio MUTE
ENVIN	ENVelope INput	TPZ (TRAPE)	TraPeZoid (TRAPEzoid)
ESW	Eject SWitch	TRK	TRAcking
EQ	EQUALizer	TRP	Take up Reel Pulse
FE	Full track Erase	T/U	Take Up
FF	Flip-Flop	TV	TeleVision
FG	Frequency Generator	UHF	Ultra High Frequency
Fig.	Figure	UNR	UNRegulated
FM	Frequency Modulation	V	Vertical
Fo	resonance Frequency	VCO	Voltage Controlled Oscillator
FREQ	FREQUENCY	VD	Vertical Drive
FSI	Field Start Inhibit	VF	Voltage for Fine tuning
GND	GrouND	VHF	Very High Frequency
H	Horizontal	VHS	Video Home System
HP	Horizontal (sync) Pulse	VID	VIDeo
HPF	High Pass Filter	VIDEO-J	VIDEO Judge
HT	HeaTer	VIF	Video Intermediate Frequency
IC	Integrated Circuit	VJ	Video Judge
ID	IDentification	VM	Voltage for Memory
IDL	IDLe (Voltage)	VOB	Video On Blank
INS	INSert	VOW	Video On Word
INV	INVerter	VP	Vertical (sync) Pulse
L-CTL	Lamp-ConTrol	VT	Voltage for Tuning
LED	Light Emitting Diode	WHT	WHITe
LDI	LoaD Input	2H	2 Hour (SP)
LM	Loading Motor	6H	6 Hour (SLP)

AKAI

MODEL **VS-205EK**

MODEL **VS-240**^{EA/EG/EK/ES/EO}
_{/EO(Y3)/EV/EZ}

MODEL **VS-245ES**

SCHEMATIC DIAGRAM AND PC BOARDS

TABLE OF CONTENTS

1. SCHEMATIC DIAGRAM OF ICs	2
2. POWER BLOCK DIAGRAM.....	5
3. AUDIO BLOCK DIAGRAM	6
4. SYSTEM CONTROL BLOCK DIAGRAM	7
5. SERVO BLOCK DIAGRAM	8
6. VIDEO BLOCK DIAGRAM.....	9
7. CONNECTION DIAGRAM	10
8. TRANS PC BOARD AND OTHER PC BOARDS	11
9. MAIN SCHEMATIC DIAGRAM	12
10. MAIN PC BOARD.....	13
11. OPERATION(A)/(B) SCHEMATIC DIAGRAM	14
12. OPERATION(A)/(B) PC BOARD.....	15
13. RC-V240A/B REMOTE CONTROL UNIT SCHEMATIC DIAGRAM.....	16

EHM-M96A8U63K-2 (VIDEO Y. SIGNAL PROCESSING IC)

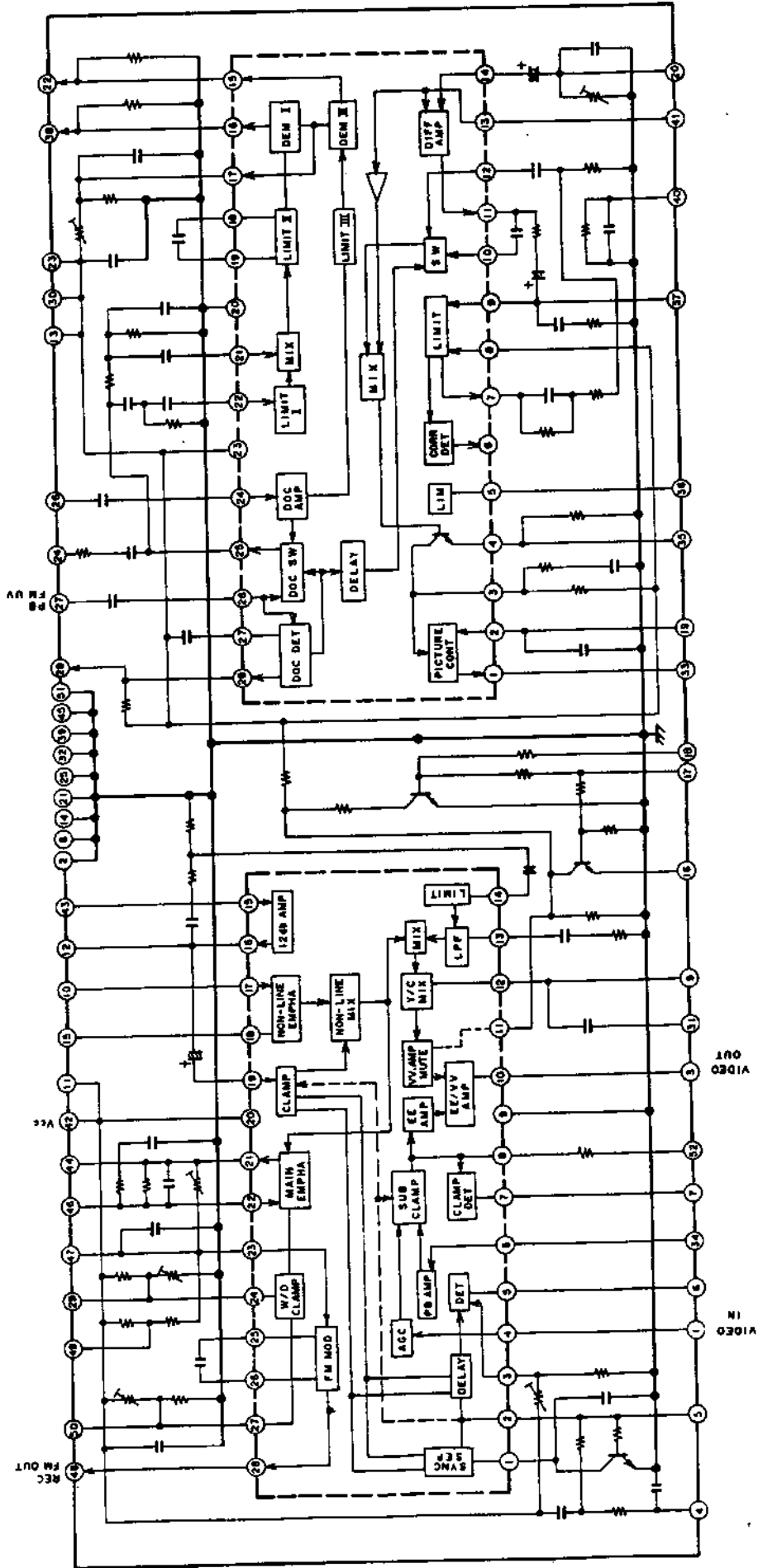

MB88521-140M (SYSTEM CONTROL CPU)

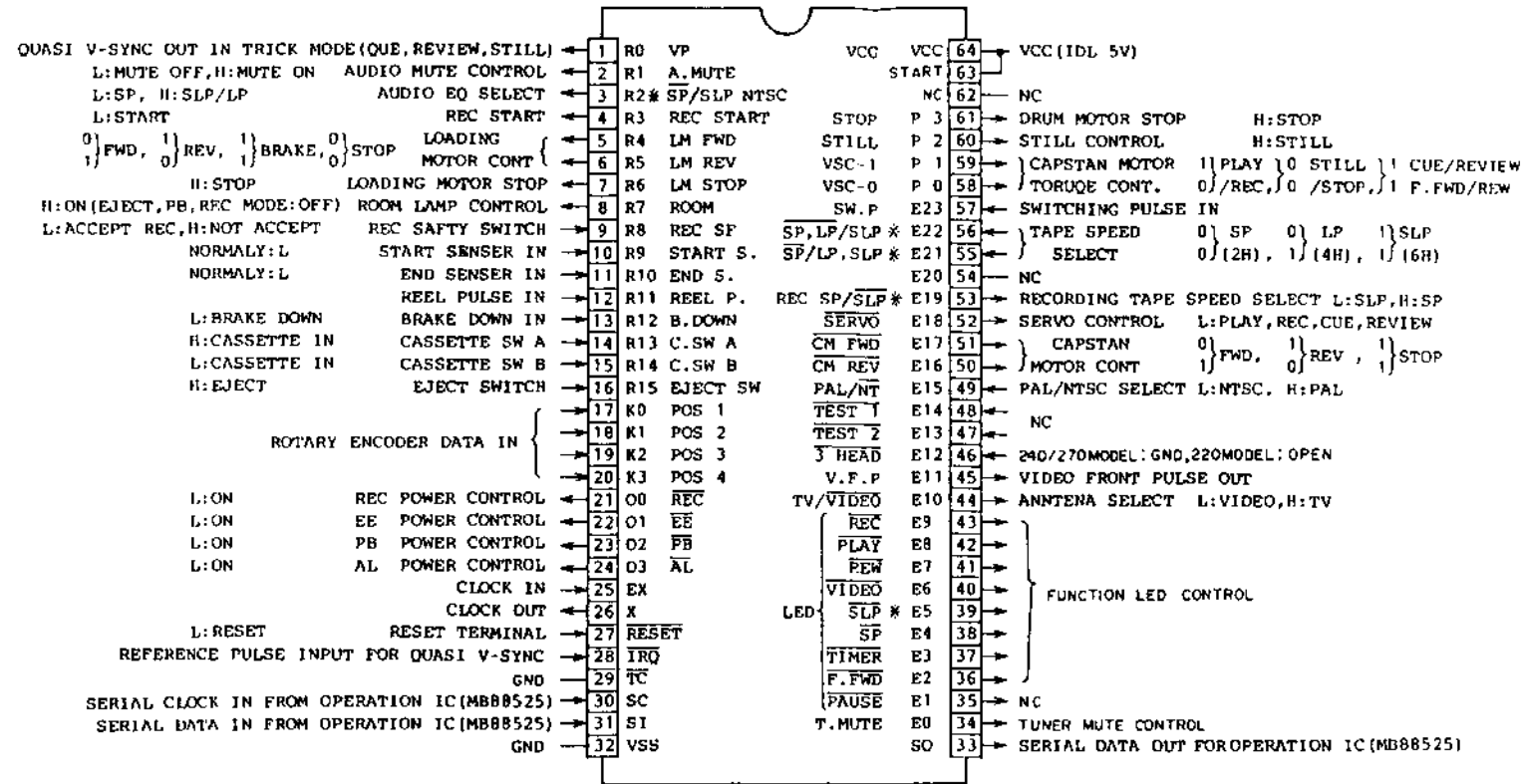

* : NTSC MODEL ONLY

MB88551-256N, 257N [OPERATION CPU (C-MOS 8K)]

Pin No.	Symbol	Remarks
1.	SI/O	Serial data input from Syscon CPU
2.	SPM	Speed mode input L:SP, H:SP/SLP
3.	SDA	NC
4.	SW SLP	Speed selector input L:SLP, H:SP
5.	DI0, I/O4	Data IN/OUT, Connect D/A converter, NVRAM
6.	DI1, I/O3	
7.	DI2, I/O2	
8.	DI3, I/O1	
9.	OPEN	NC
10.	AVSS	A/D converter ground
11.	AVR-	A/D converter minus ref. voltage
12.	AVCC	A/D converter VCC
13.	A6, KOT2	NVRAM address output/ key scan pulse output
14.	A5, KOT3	
15.	A0, KOT0	
16.	A1 KOT1	NVRAM address output
17.	A2	
18.	A3	
19.	A4	
20.	A7	Key scan input
21.	KIN3	
22.	KIN2	
23.	KIN1	
24.	KIN0	NC
25.	VPS AUTO	
26.	RC	NVRAM Recall L:Recall, H:don't care
27.	MEMO 1	MEMO LED control L:Lit
28.	MEMO 2	
29.	PRESET	PRESET, BAND SELECT SLIDE switch input (low active)
30.	NORMAL	
31.	BAND 1	
32.	BAND 2	
33.	OPEN	NC
34.	VCC	+B
35.	DAVN	NC
36.	NC (EI)	NC
37.	SW KE1	Scan pulse output
38.	SW KE2	PAUSE LED control
39.	PAUSE	

Pin No.	Symbol	Remarks
40.	U	Tuner band out L:ON, H:OFF
41.	VH	
42.	VC	
43.	TUNER	Tuner ON/OFF control L:ON, H:OFF
44.	B/V	Black picture control L:VIDEO, H:Black picture
45.	AFC	Tuner AFC control L:ON, H:OFF
46.	T.MUTE	Tuner mute control L:OFF, H:ON
47.	DGT 1	7 Segment LED control
48.	DGT 2	
49.	NC	
50.	NC	
51.	SEG b	
52.	SEG g	
53.	SEG a	
54.	SEG d	
55.	SEG e	
56.	SEG c	
57.	SEG f	
58.	E23	NC
59.	EX	EXT X'tal terminal
60.	X	
61.	RESET	System reset input
62.	X	Inverted oscillator output
63.	DATA	Control data output for IMS IC
64.	E25	NC
65.	CLK	Serial clock output
66.	IRQ	Remote control input
67.	E28	NC
68.	START	Power down detector input L:Power down H:don't care
69.	E30	NC
70.	E31	NC
71.	VSS	Ground
72.	SCL	NC
73.	OPEN	NC
74.	SO/I	Serial data output, connect syscon CPU
75.	SC	Clock signal output connect syscon CPU
76.	LDI	D/A converter control clock output
77.	ST	NVRAM store control L:Store, H:don't care
78.	STB PD	IMS IC data store output
79.	CS MS	NVRAM chip select L:Select, H:don't care
80.	WE	NVRAM write enable L:Write, H:Read

TA8604N (CHROMA SIGNAL PROCESSING IC)

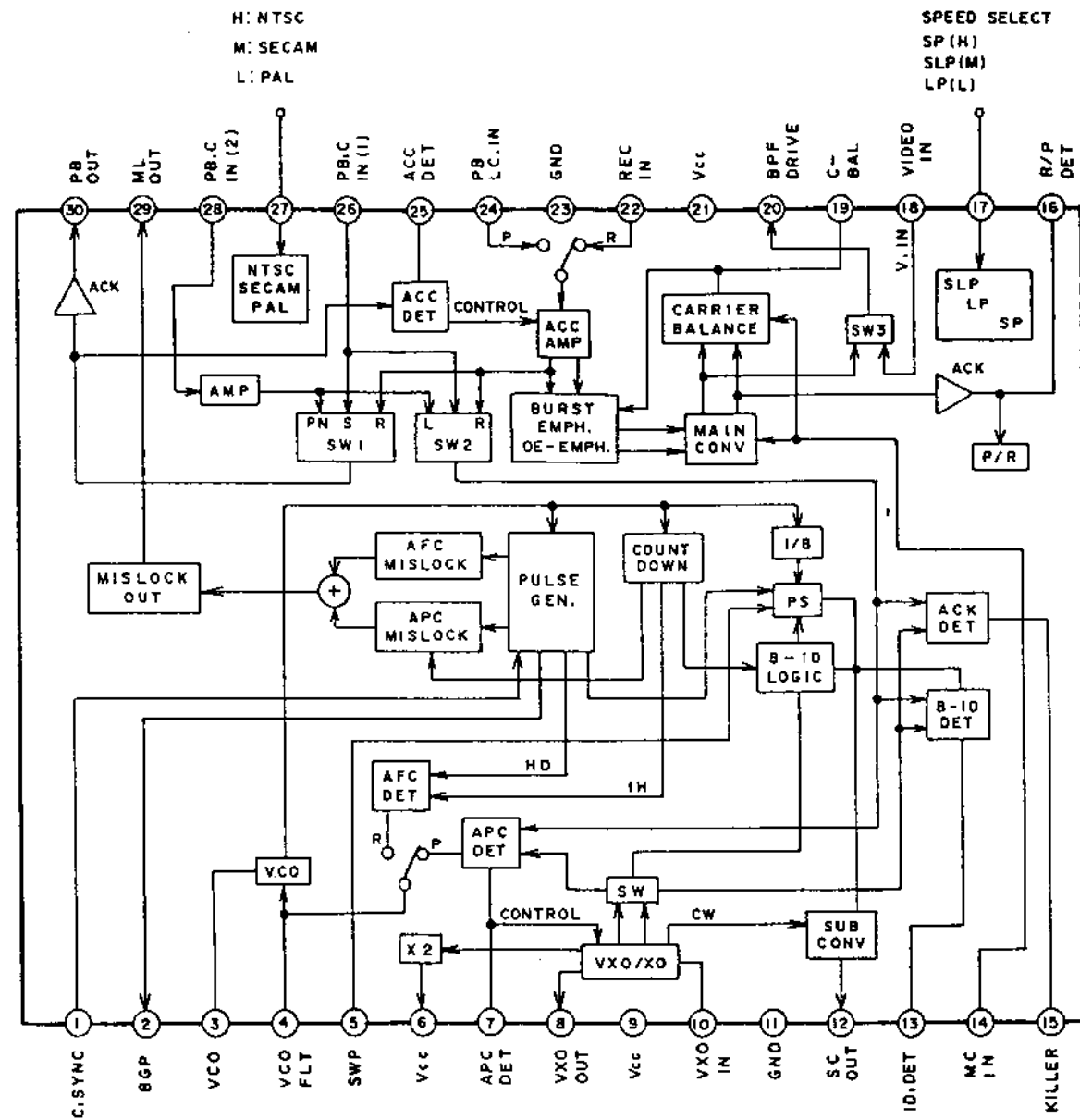

μPD6105C-002 (CHARACTOR GENERATOR)

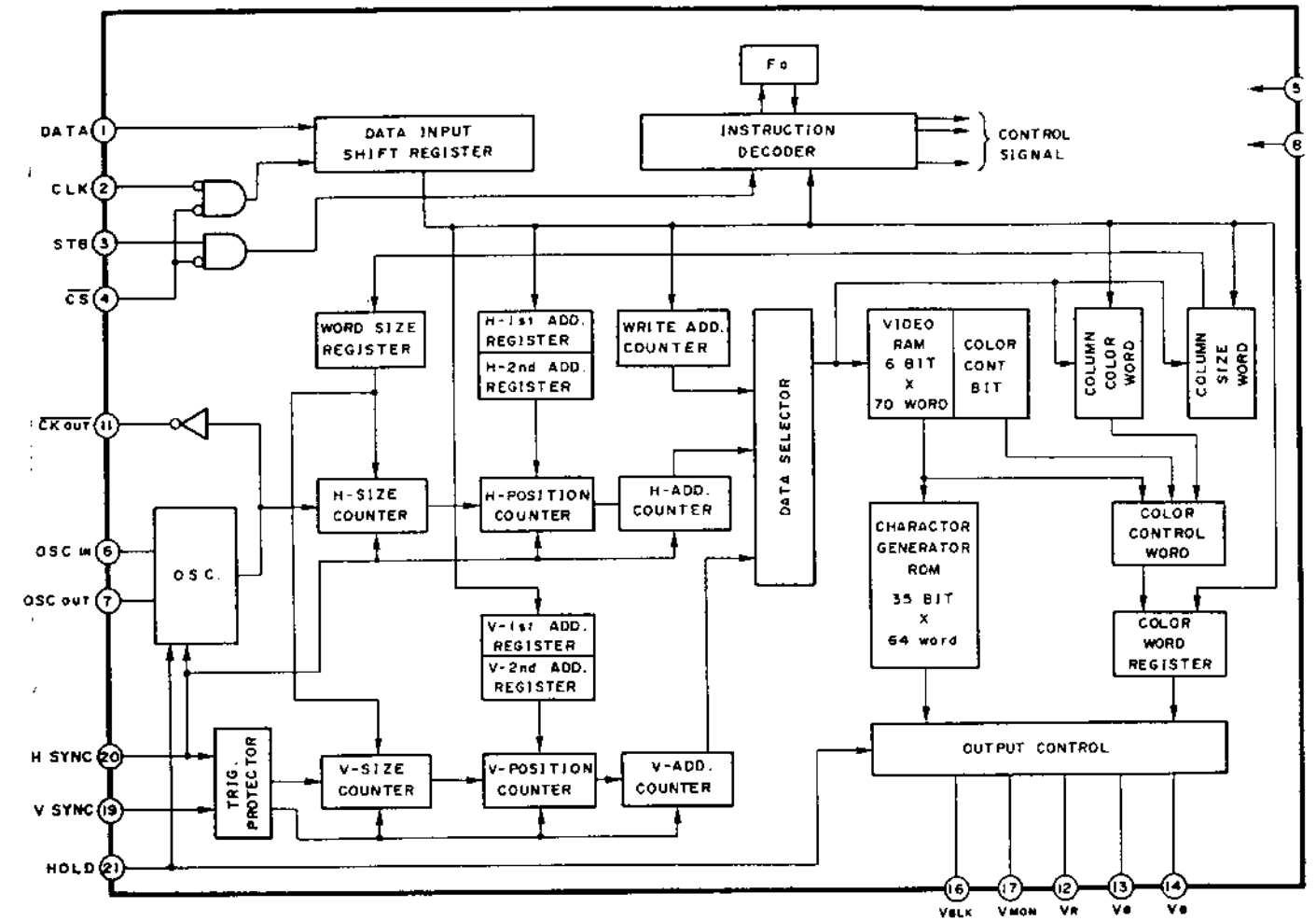

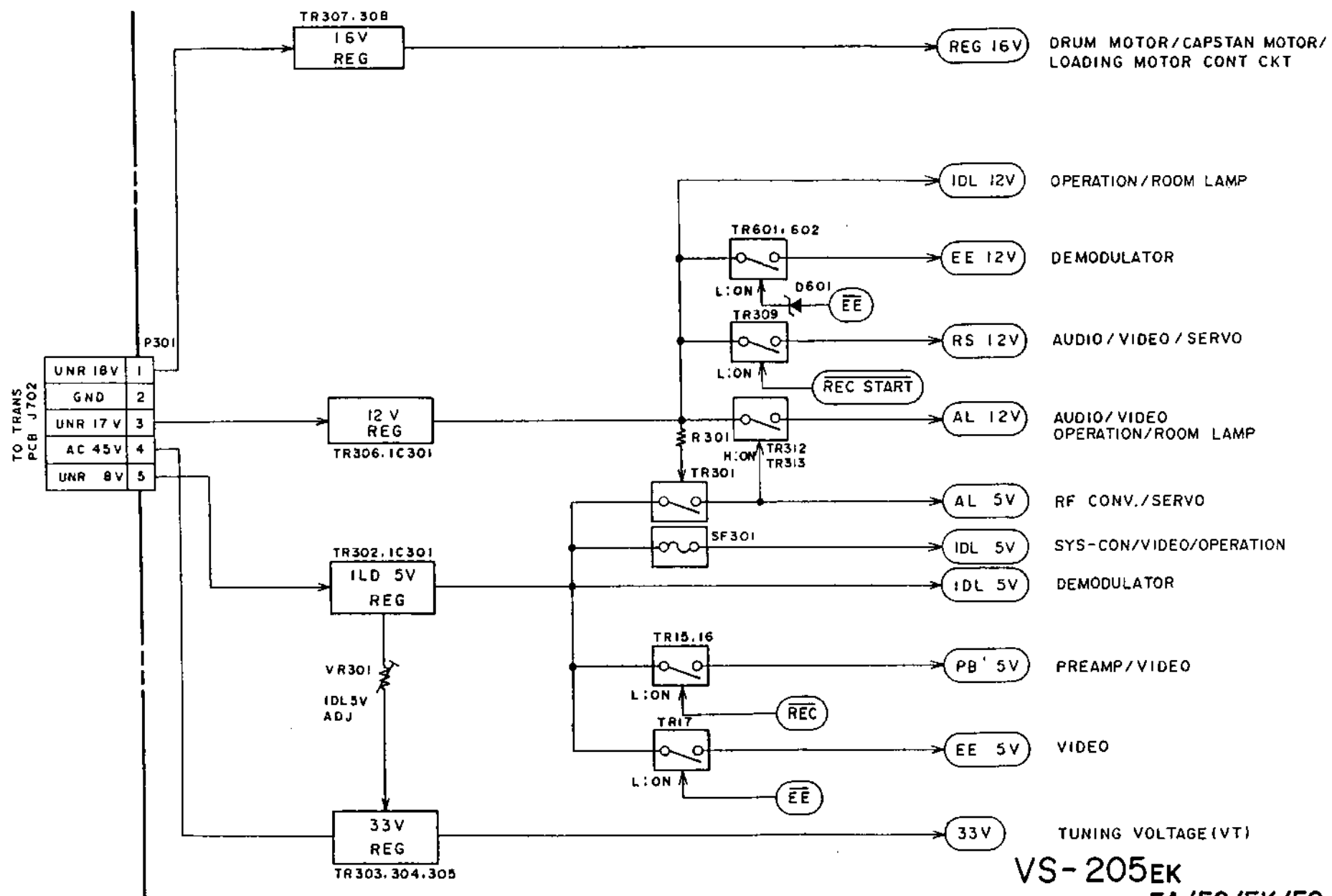

VS-205EK
 EA/EG/EK/EO
 VS-240ES/EV/EZ/EO(Y3)
 VS-245ES
 POWER BLOCK DIAGRAM
 NO. 5-1 870224A_(A4)

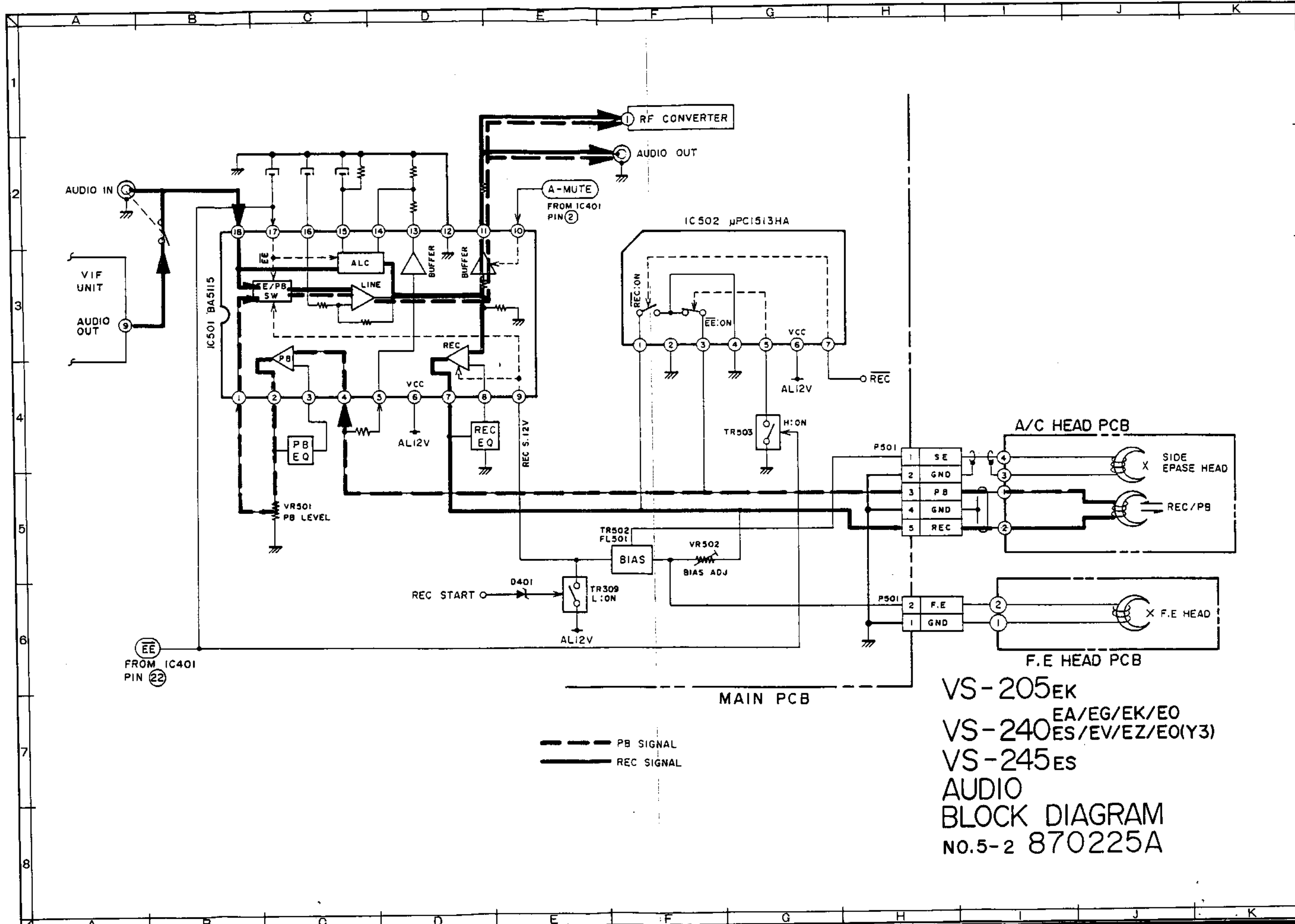

VS-205EK
 VS-240^{EA/EG/EK/EO}
 VS-245^{ES/EV/EZ/EO(Y3)}
 VS-245^{ES}
 AUDIO
 BLOCK DIAGRAM
 No.5-2 870225A

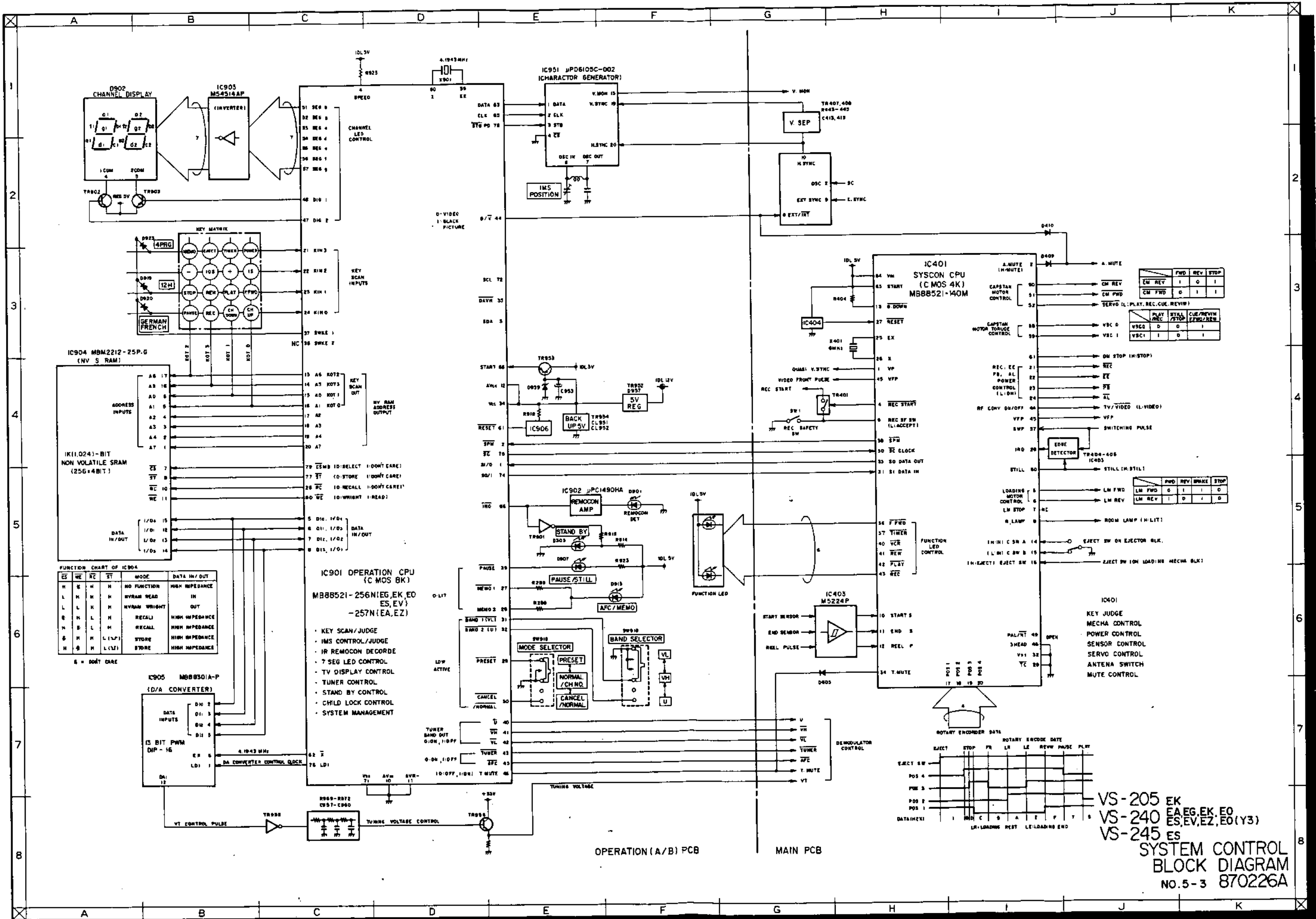

FUNCTION CHART OF IC904

ES	WE	RE	ST	MODE	DATA IN/OUT
H	H	H	H	NO FUNCTION	HIGH IMPEDANCE
L	H	H	H	NRVAM READ	IN
L	L	H	H	NRVAM WRITE	OUT
H	L	L	H	RECALL	HIGH IMPEDANCE
H	H	L	H	RECALL	HIGH IMPEDANCE
H	H	H	L	STORE	HIGH IMPEDANCE
H	H	H	H	STORE	HIGH IMPEDANCE

Note: H = DON'T CARE

- IC901 OPERATION CPU (C MOS BK) M88521-256N (EG, EK, E0 ES, EV) -257N (EA, EZ)**
- KEY SCAN/JUDGE
 - IMS CONTROL/JUDGE
 - IR REMOCON DECODE
 - 7 SEG LED CONTROL
 - TUNER CONTROL
 - STAND BY CONTROL
 - CHILD LOCK CONTROL
 - SYSTEM MANAGEMENT

VS-205 EK
 VS-240 EA, EG, EK, E0
 ES, EV, EZ, E0 (Y3)
 VS-245 ES
**SYSTEM CONTROL
 BLOCK DIAGRAM
 NO.5-3 870226A**

OPERATION (A/B) PCB

MAIN PCB

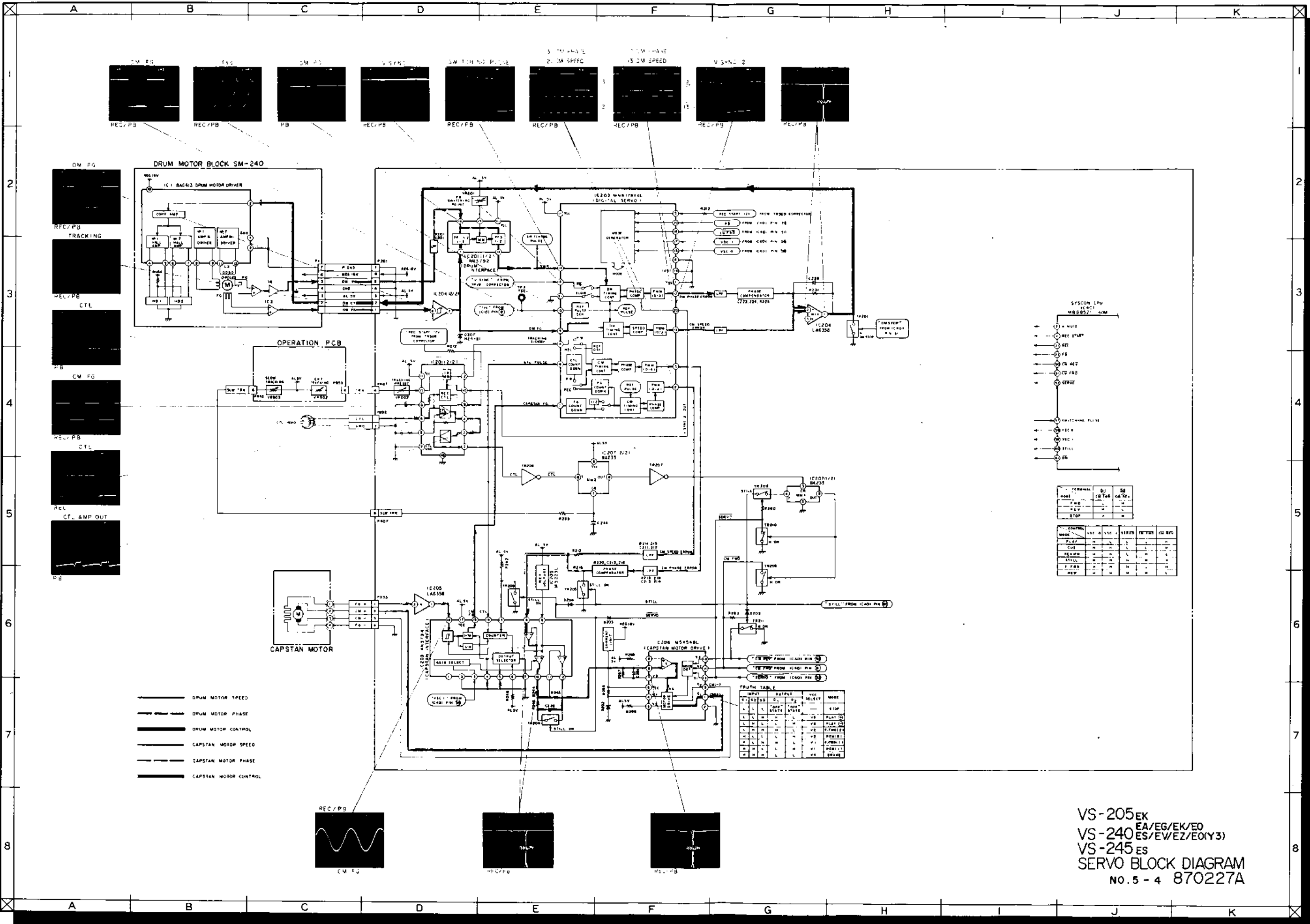

VS-205EK
 EA/EG/EK/EO
 VS-240ES/ES/EW/EZ/EO(Y3)
 VS-245ES
 SERVO BLOCK DIAGRAM
 NO. 5 - 4 870227A

VS-220U

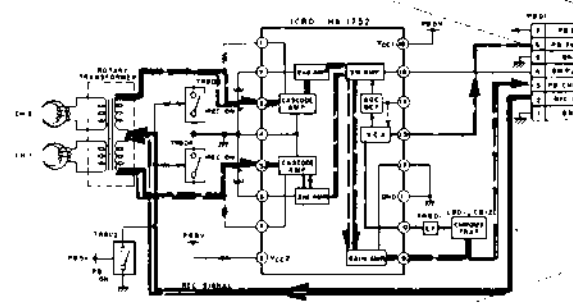
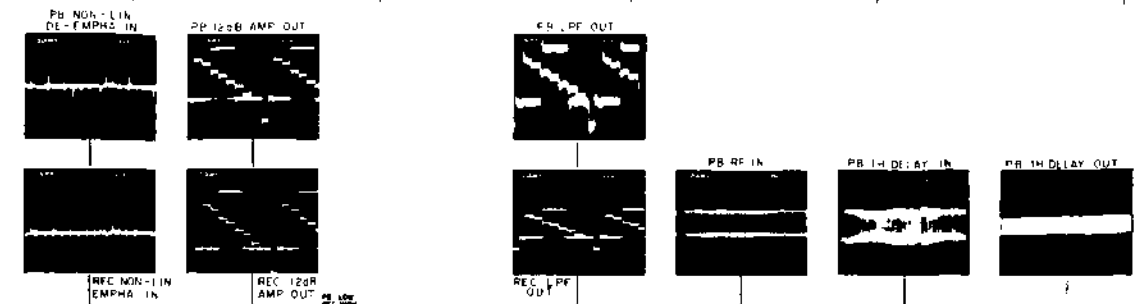

PREAMP PCB

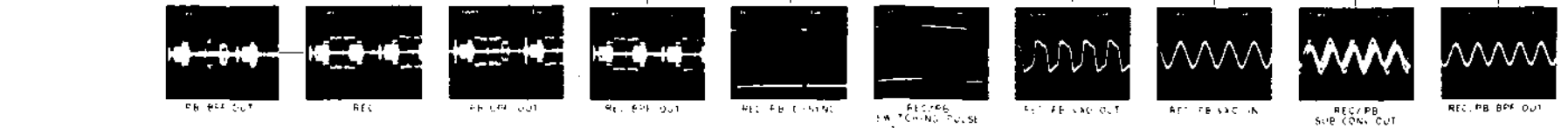
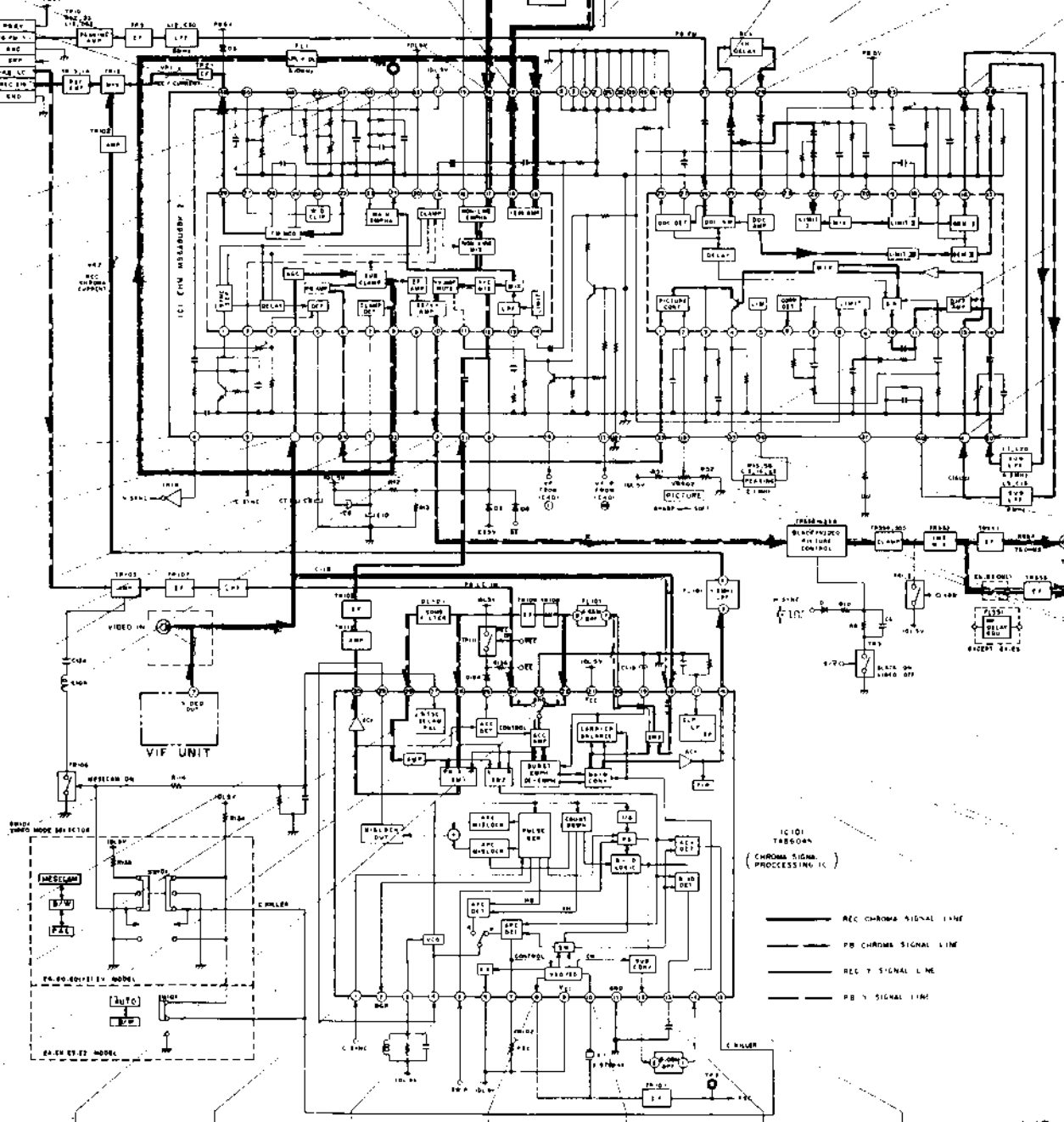
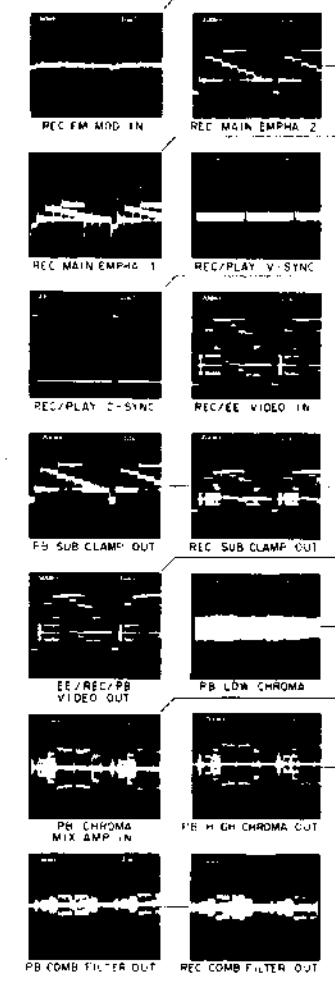

REC CHROMA SIGNAL LINE
PB CHROMA SIGNAL LINE
REC Y SIGNAL LINE
PB Y SIGNAL LINE

VS-205EK
VS-240EA/EG/EK/E0
VS-240ES/EV/EZ/E0(Y3)
VS-245ES
VIDEO BLOCK DIAGRAM
NO.5-5 870228A

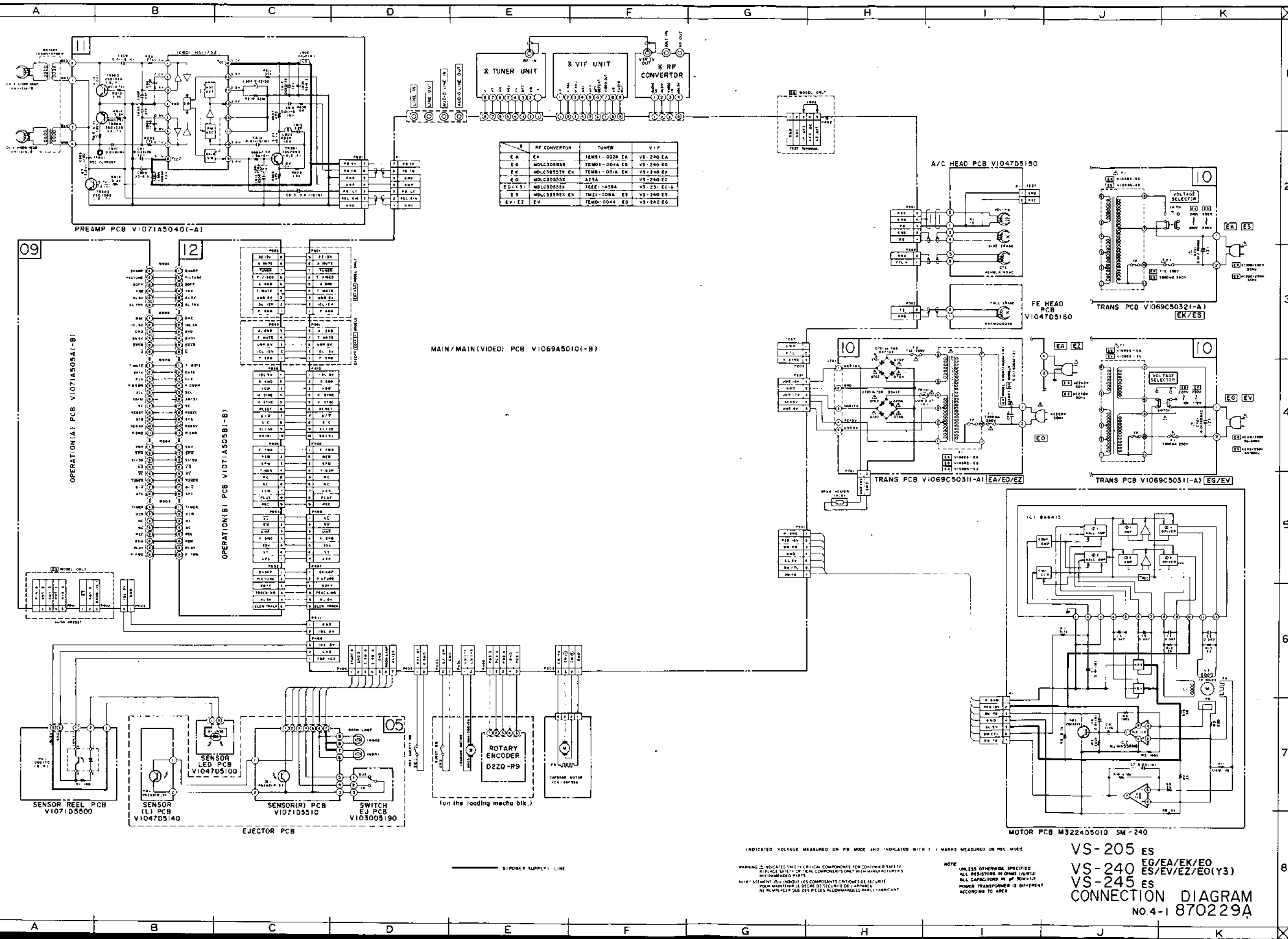

INDICATED VOLTAGE MEASURED ON PR MODE AND INDICATED WITH () MARKS MEASURED ON REC MODE

WARNING: INDICATES SAFETY CRITICAL COMPONENTS FOR CONTINUED SAFETY. REPLACE SAFETY CRITICAL COMPONENTS ONLY WITH MANUFACTURER'S RECOMMENDED PARTS.

NOTE: UNLESS OTHERWISE SPECIFIED, ALL RESISTORS IN OHMS (R/W/L). ALL CAPACITORS IN PF (P/W/L). POWER TRANSFORMER IS DIFFERENT ACCORDING TO AREA.

VS-205 ES
 VS-240 EG/EA/EK/EO
 VS-245 ES/EV/EZ/EO(Y3)
CONNECTION DIAGRAM
 NO.4-1 870229A

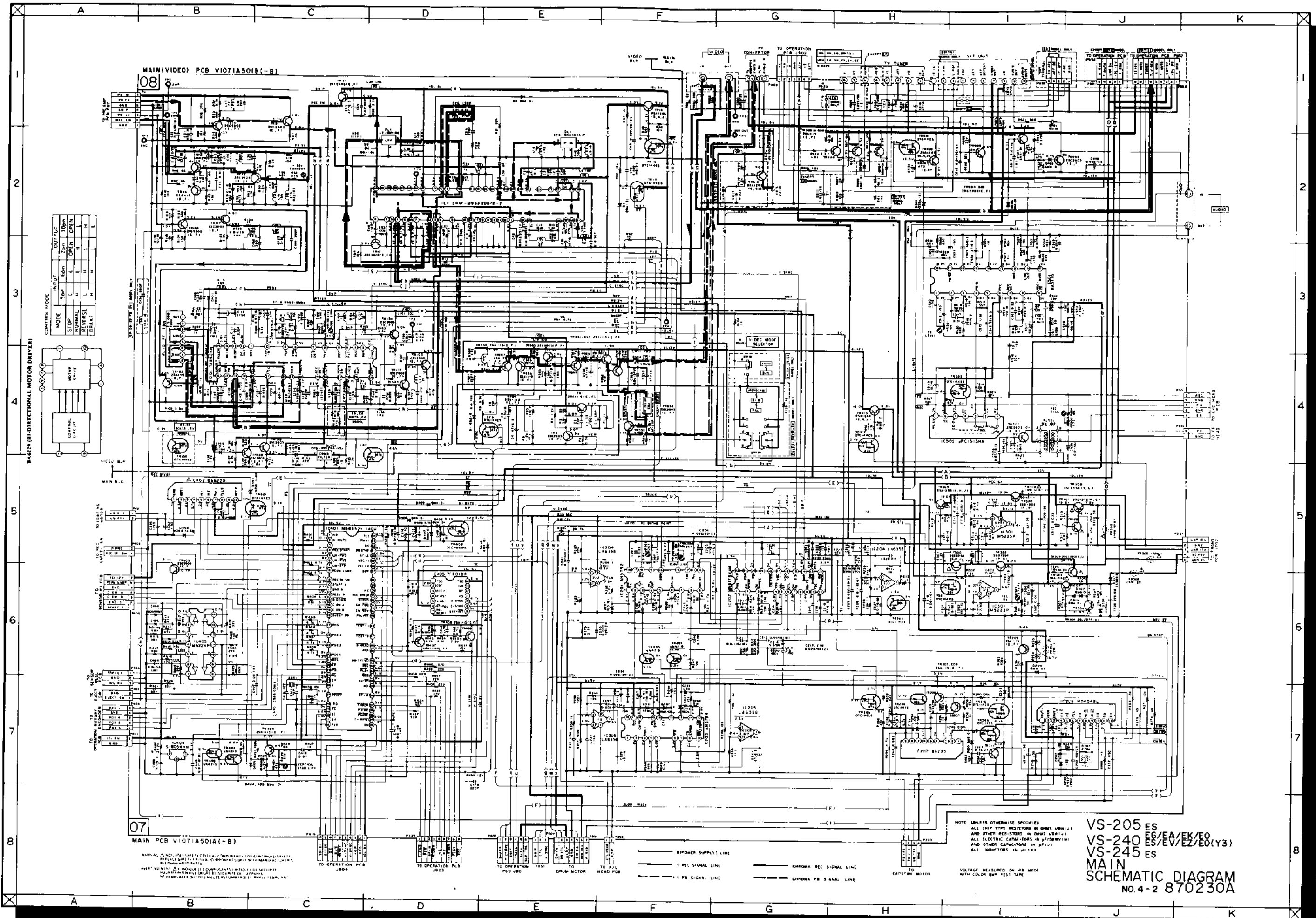

09

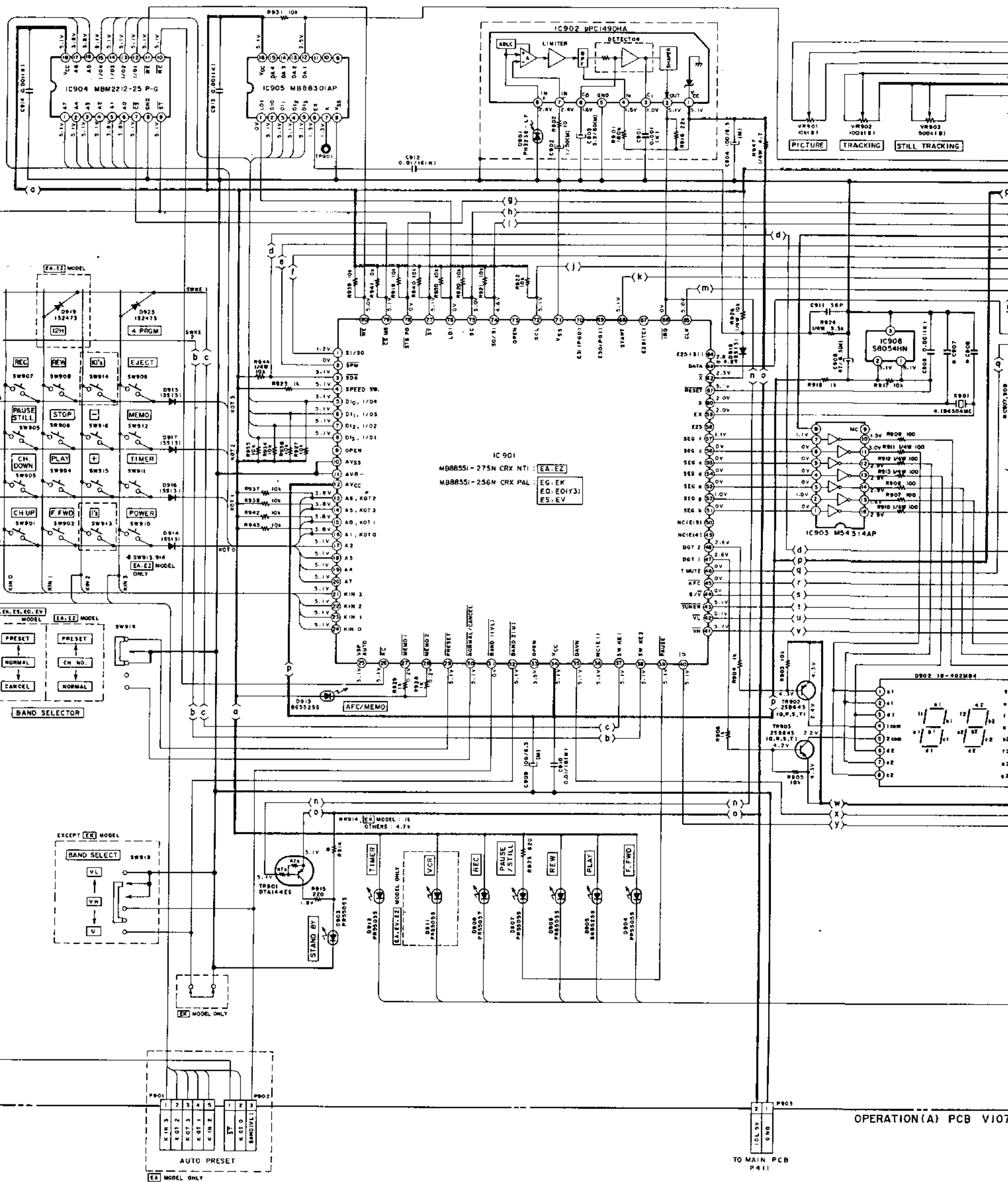

OPERATION (A) PCB V107

TO MAIN PCB P411

B (POWER SUPPLY) LINE

VOLTAGE MEASURED ON EE15T0

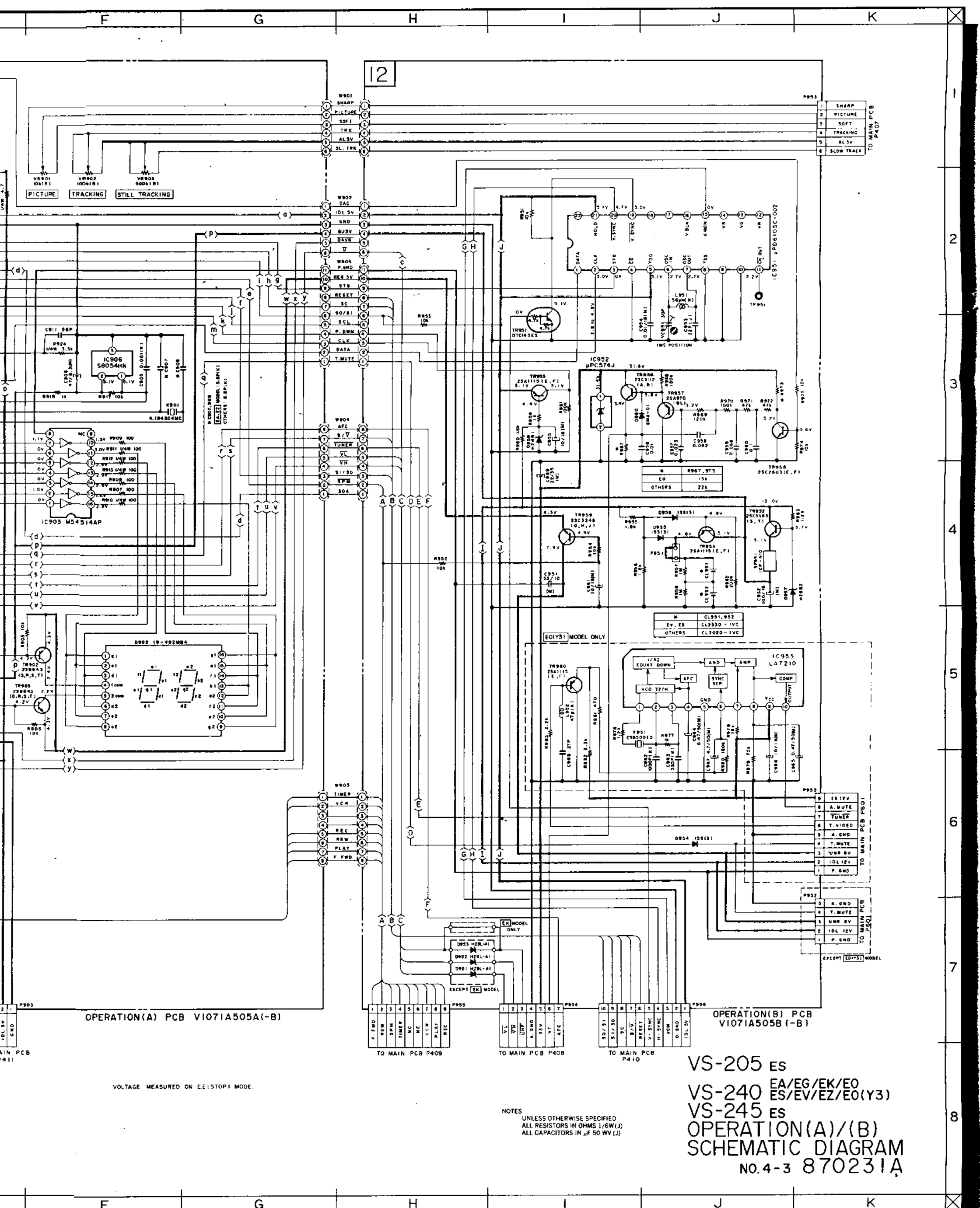

OPERATION(A) PCB V1071A505A(-B)

OPERATION(B) PCB V1071A505B(-B)

VOLTAGE MEASURED ON EE1STOP1 MODE.

NOTES
UNLESS OTHERWISE SPECIFIED
ALL RESISTORS IN OHMS 1/6W(J)
ALL CAPACITORS IN μ F 50 WV (J)

VS-205 ES
VS-240 EA/EG/EK/E0
VS-245 ES/EV/EZ/E0(Y3)
VS-245 ES
OPERATION(A)/(B)
SCHEMATIC DIAGRAM
NO. 4-3 870231A

PRINCIPAL PARTS LOCATION

IC's

- IC 1....FG6
- IC101....A6
- IC201....E4
- IC202....D4
- IC203....D3,4
- IC204....E3
- IC205....E3
- IC206....D3
- IC207....C3
- IC301....CD1
- IC401....AB3
- IC402....B1,2
- IC403....AB1
- IC404....A4
- IC405....B4
- IC501....FG4
- IC501....FG3

CONNECTOR'S

- P 1....DE6
- P201....E3
- P202....E4
- P203....E3
- P204....E4
- P301....E1
- P401....B2
- P402....A3
- P403....A3
- P404....A2
- P405....A3
- P406....B1
- P407....A2
- P408....A2
- P409....A3
- P410....A3,4
- P411....B3
- P501....FG3
- P502....P3

TRANSISTOR'S

- | | |
|----------------|----------------|
| TR 1....F5 | TR301....C1 |
| TR 2....F5 | TR302....C1 |
| TR 3....F5 | TR303....C1 |
| TR 9....E6 | TR304....C1 |
| TR 10....E6 | TR305....C1 |
| TR 12....D6 | TR306....D1 |
| TR 13....D6 | TR307....C2 |
| TR 14....D6 | TR308....D2 |
| TR 15....D6 | TR309....C2 |
| TR 16....CD5,6 | TR311....C2 |
| TR 17....C5,6 | TR312....F3 |
| TR 19....G5 | TR313....F3 |
| TR 21....E6 | TR401....A2 |
| TR101....A6 | TR403....A2 |
| TR102....C6 | TR404....A1 |
| TR103....C6 | TR405....A1 |
| TR105....D6 | TR406....A1 |
| TR106....C6 | TR407....AB4,5 |
| TR107....C6 | TR408....A4,5 |
| TR108....B6 | TR409....B2 |
| TR109....B6 | TR502....G3 |
| TR111....B5 | TR503....G3 |
| TR112....B5,6 | TR551....G4 |
| TR201....E3 | TR552....G4,5 |
| TR202....C3 | TR553....G4 |
| TR203....D3 | TR554....G5 |
| TR204....D3 | TR555....G4,5 |
| TR205....C3 | TR557....F5 |
| TR206....C3 | TR558....F4 |
| TR207....C4 | TR601....E2 |
| TR208....C3 | TR602....F1 |
| TR209....C3 | TR603....E2 |
| TR210....C3 | TR604....F1 |
| TR211....C3 | TR605....F1 |
| | TR606....F1,2 |
| | TR607....FG1 |
| | TR608....F1 |
| | TR610....G1 |

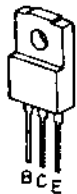

2SD1266
2SD1273



2SA1283
2SA1286
2SC3246



2SA1392
2SC2274K



UN4210



DTA114ES
DTA144ES
DTC114TS
DTC114YS
DTC144ES
DTC144WS



2SA1115
2SC2603
2SC3330

WARNING: Δ INDICATES SAFETY CRITICAL COMPONENTS FOR CONTINUED SAFETY. REPLACE SAFETY CRITICAL COMPONENTS ONLY WITH MANUFACTURER'S RECOMMENDED PARTS

AVERTISSEMENT: Δ IL INDIQUE LES COMPOSANTS CRITIQUES DE SÉCURITÉ. POUR MAINTENIR LE DEGRÉ DE SÉCURITÉ DE L'APPAREIL, NE REMPLACER QUE DES PIÈCES RECOMMANDÉES PAR LE FABRICANT

AN3792 (DRUM SERVO INTERFACE IC)

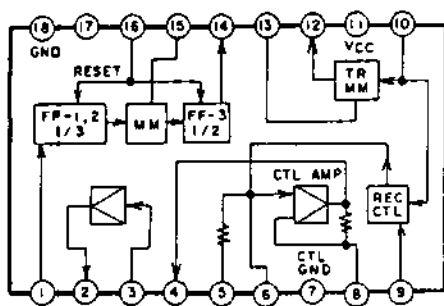

AN3794 (CAPSTAN SERVO INTERFACE IC)

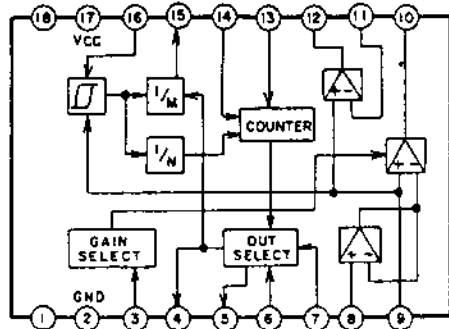

BA5115 (SWITCHLESS REC/PB AMPLIFIER)

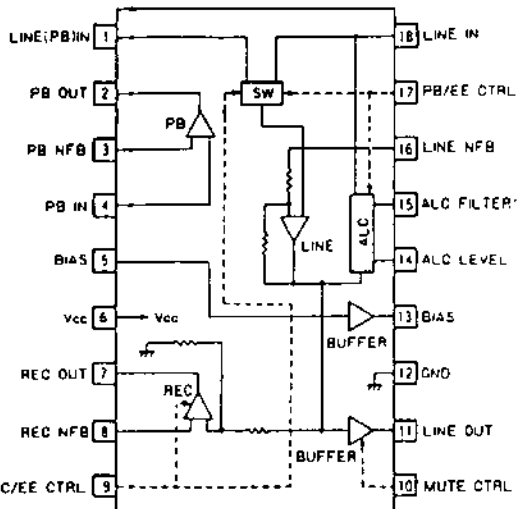

BA235A (DUAL MONO MULTI)

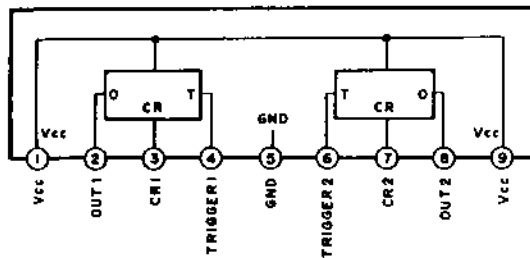

MN6178XAL (DIGITAL SERVO IC)

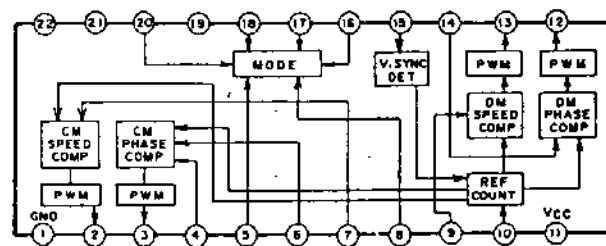

M54548L (CAPSTAN DRIVE IC)

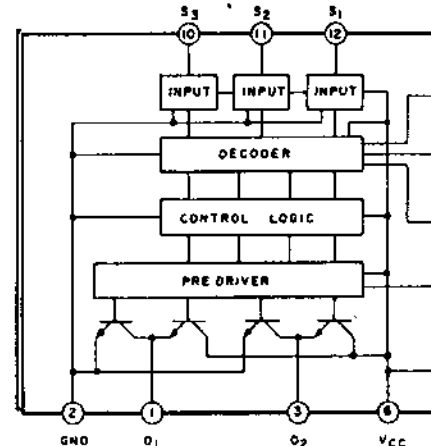

MAIN PCB V1071A501A (-B)

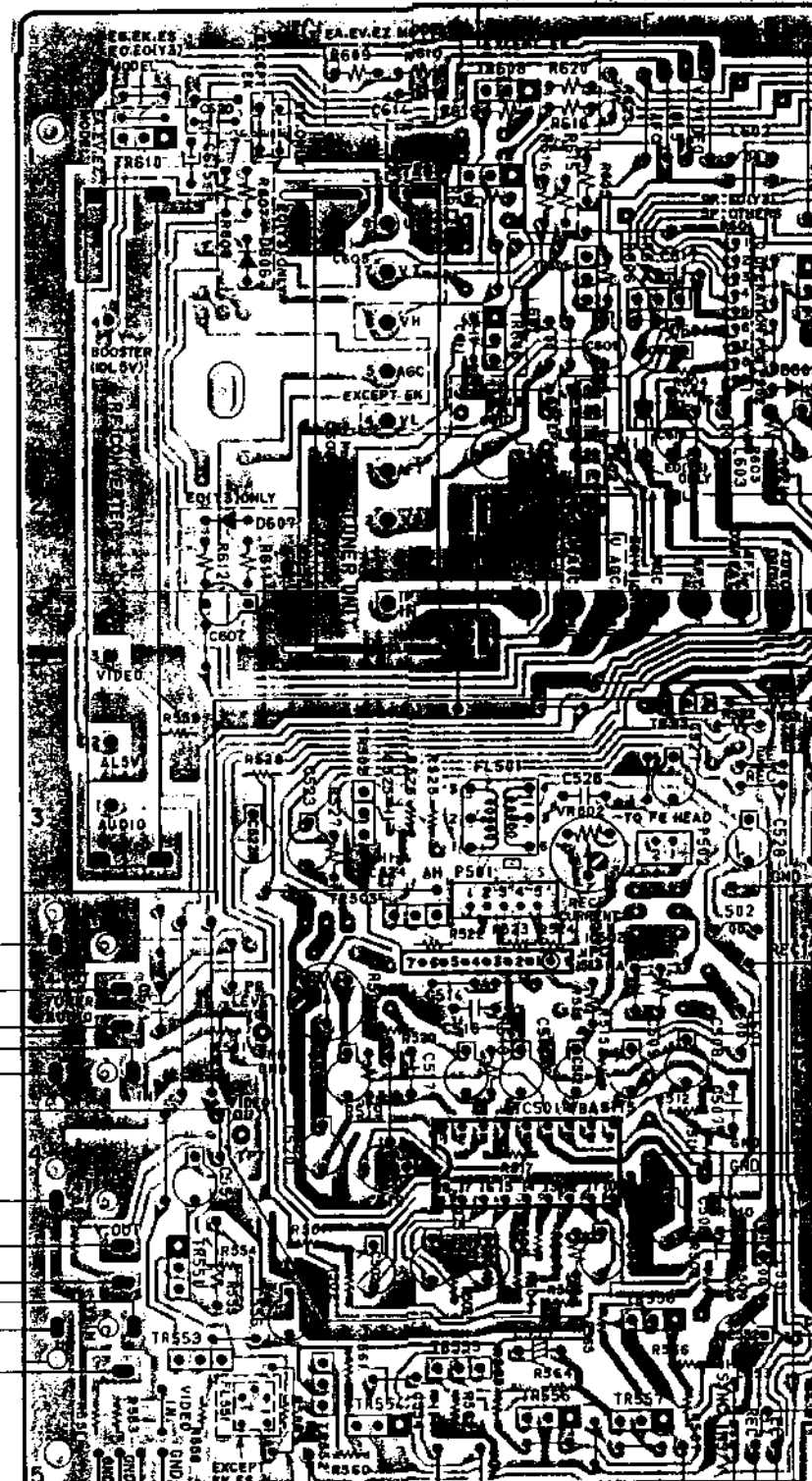

MAIN (VIDEO) PCB V1071A501B (-B)

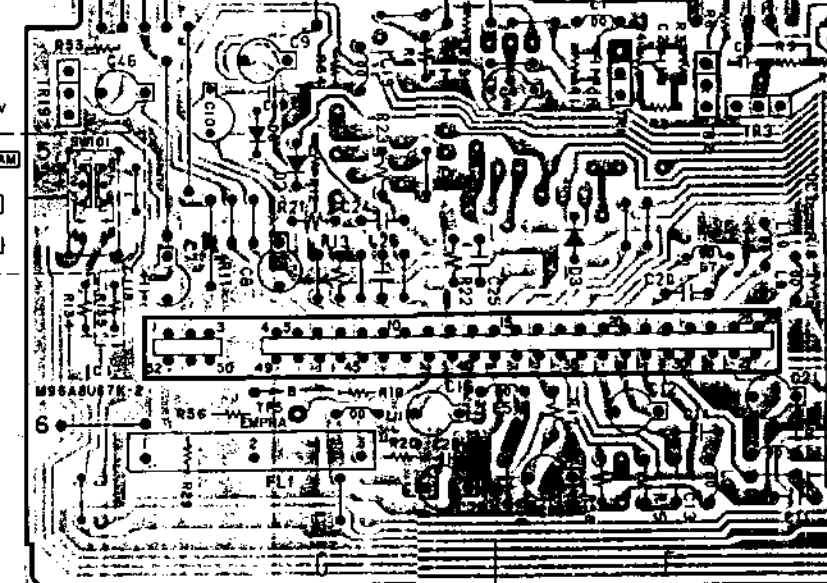

A501A (-B)

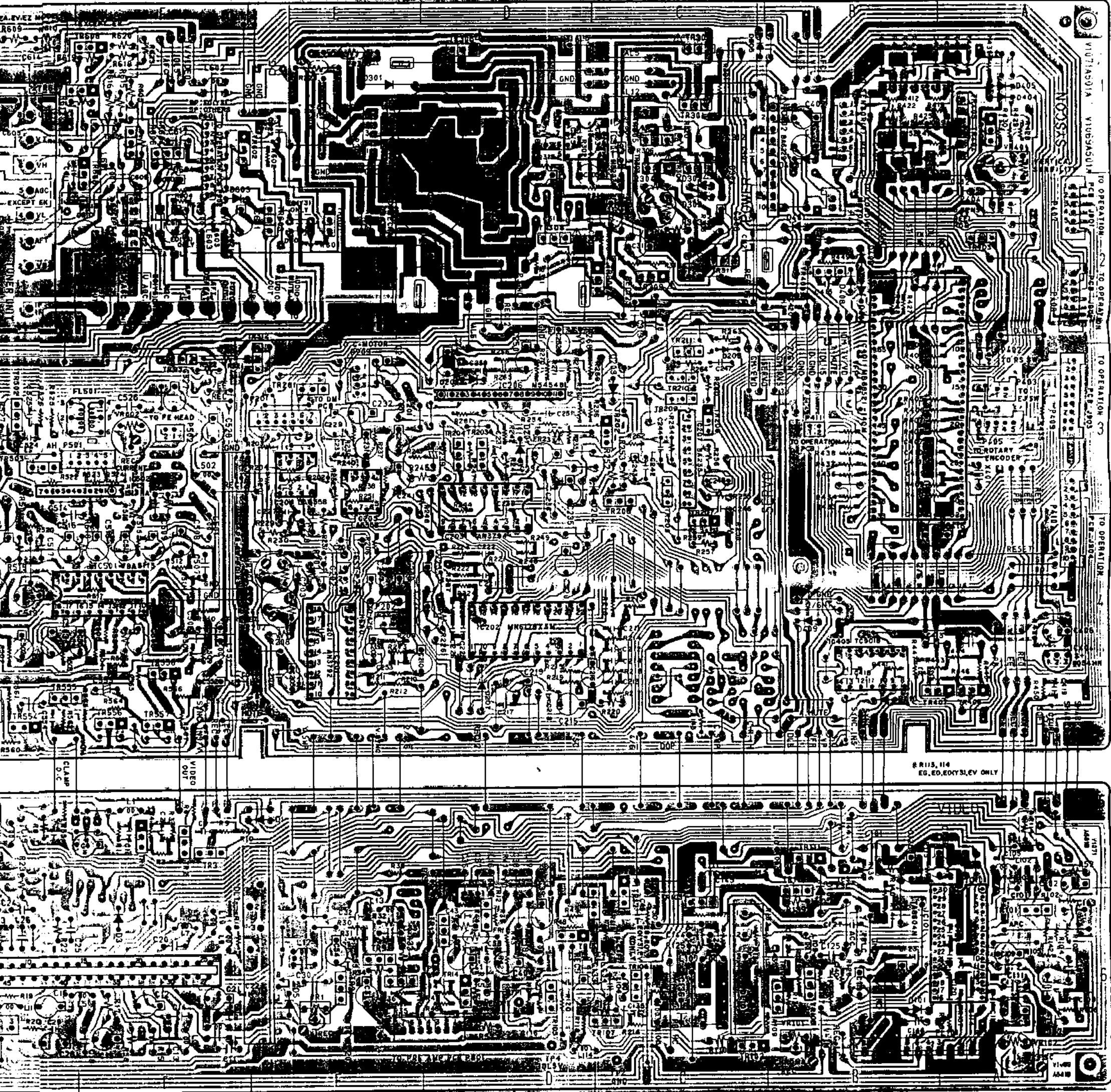

B V1071A501B (-B)

M54548L (CAPSTAN DRIVE IC)

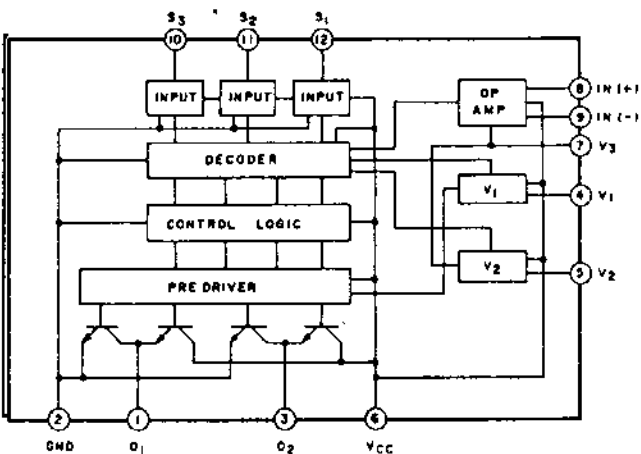

INPUT			OUTPUT		Vcc SELECT	MODE
S ₁	S ₂	S ₃	O ₁	O ₂		
L	L	L	"OFF" state	"OFF" state	-	STOP
L	L	H	H	L	V _a	PLAY (+)
L	H	L	L	H	V _b	PLAY (-)
L	H	H	H	L	V _c	FF (2)
H	L	L	L	H	V _d	REW (2)
H	L	H	H	L	V _e	FF (1)
H	H	L	L	H	V _f	REW (1)
H	H	H	L	L	V _g	BRAKE

TC9018P (TV SYNC GENERATOR)

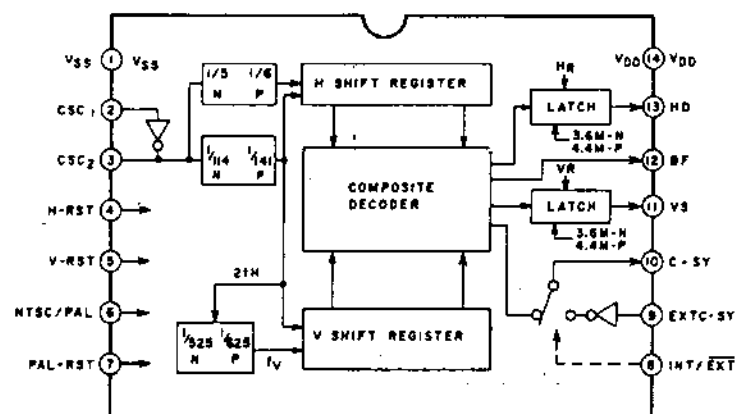

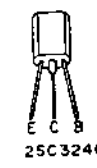
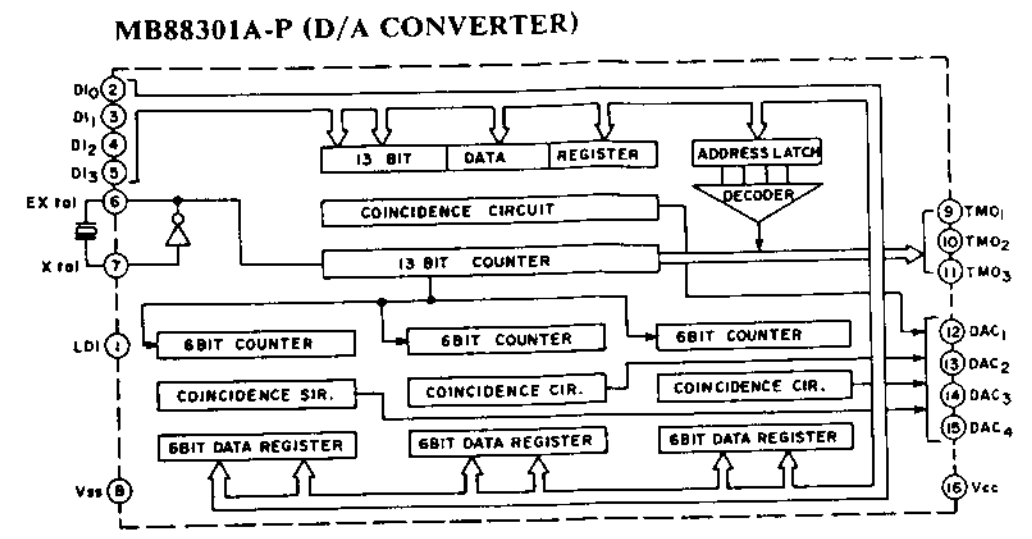
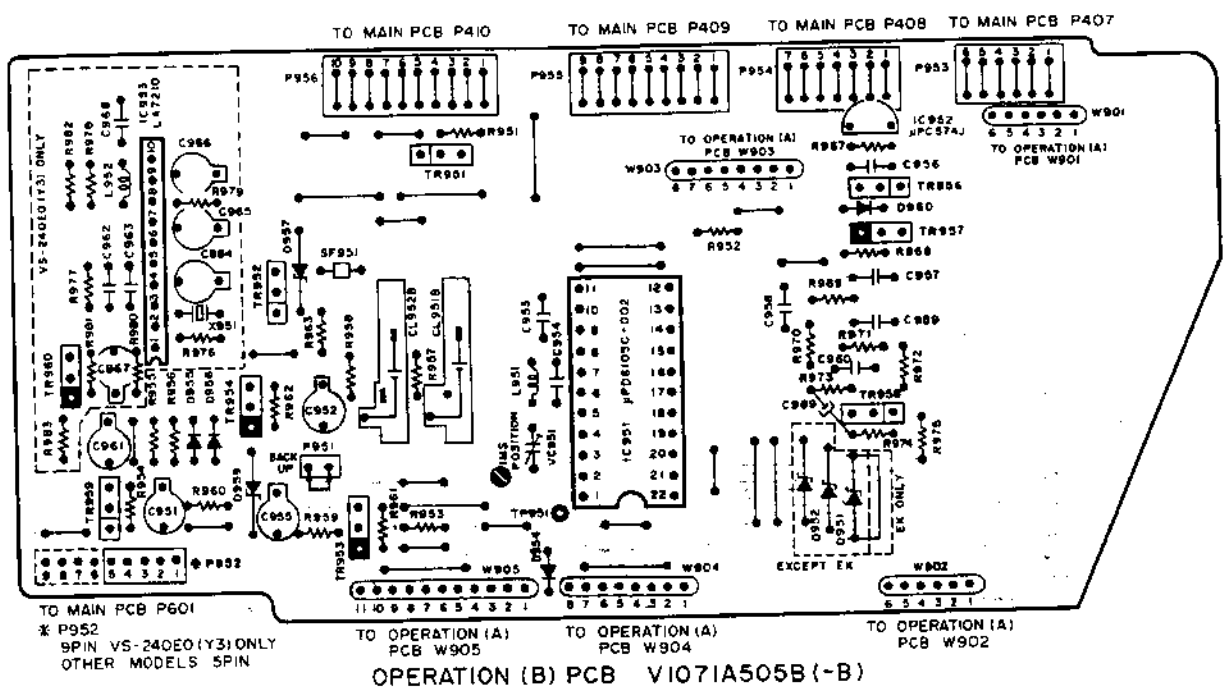

●●● : NPN TRANSISTOR
●●● : PNP TRANSISTOR

MBM2212-25 [1K(1.024)-BIT NON VOLATILE SRAM]

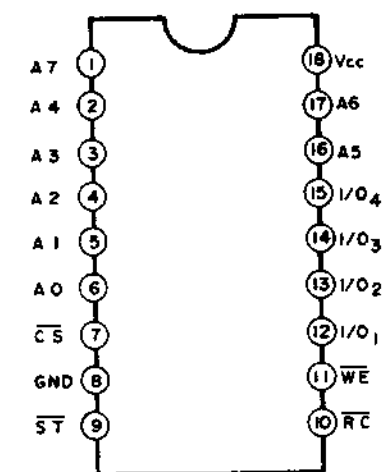

SYMBOL	PORT NAME
A0 to A7	Address inputs
I/O1 to I/O4	Data in/outputs
CS	Chip select input
WE	Write enable input
ST	Store input
RC	Recall input
V _{CC}	+B (+5V)
GND	Ground

CS	WE	RC	ST	MODE	DATE IN/OUT
H	*	H	H	NO FUNCTION	High impedance
L	H	H	H	SRAM READ MODE	IN
L	L	H	H	SRAM WRITE MODE	OUT
*	H	L	H	RECALL	High impedance
H	*	L	H	RECALL	" "
*	H	H	L	STORE	" "
H	*	H	L	STORE	" "

* : dont care

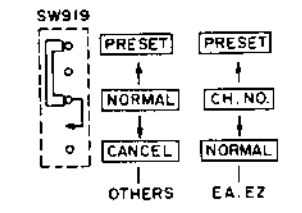
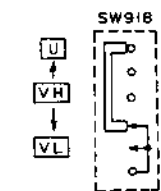
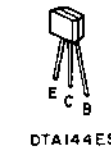
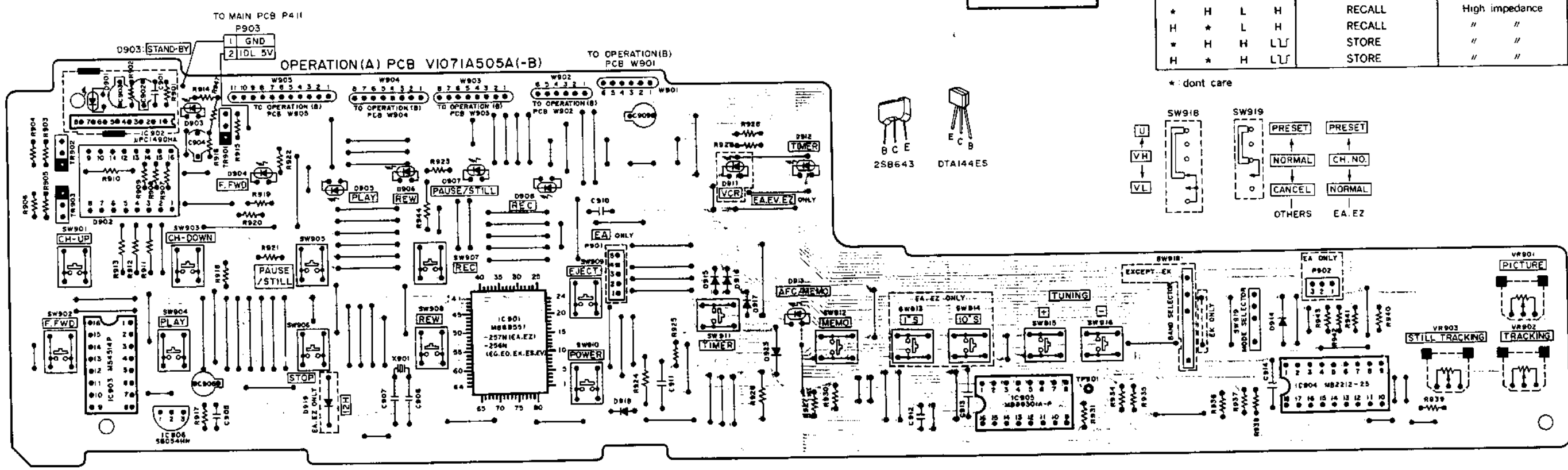

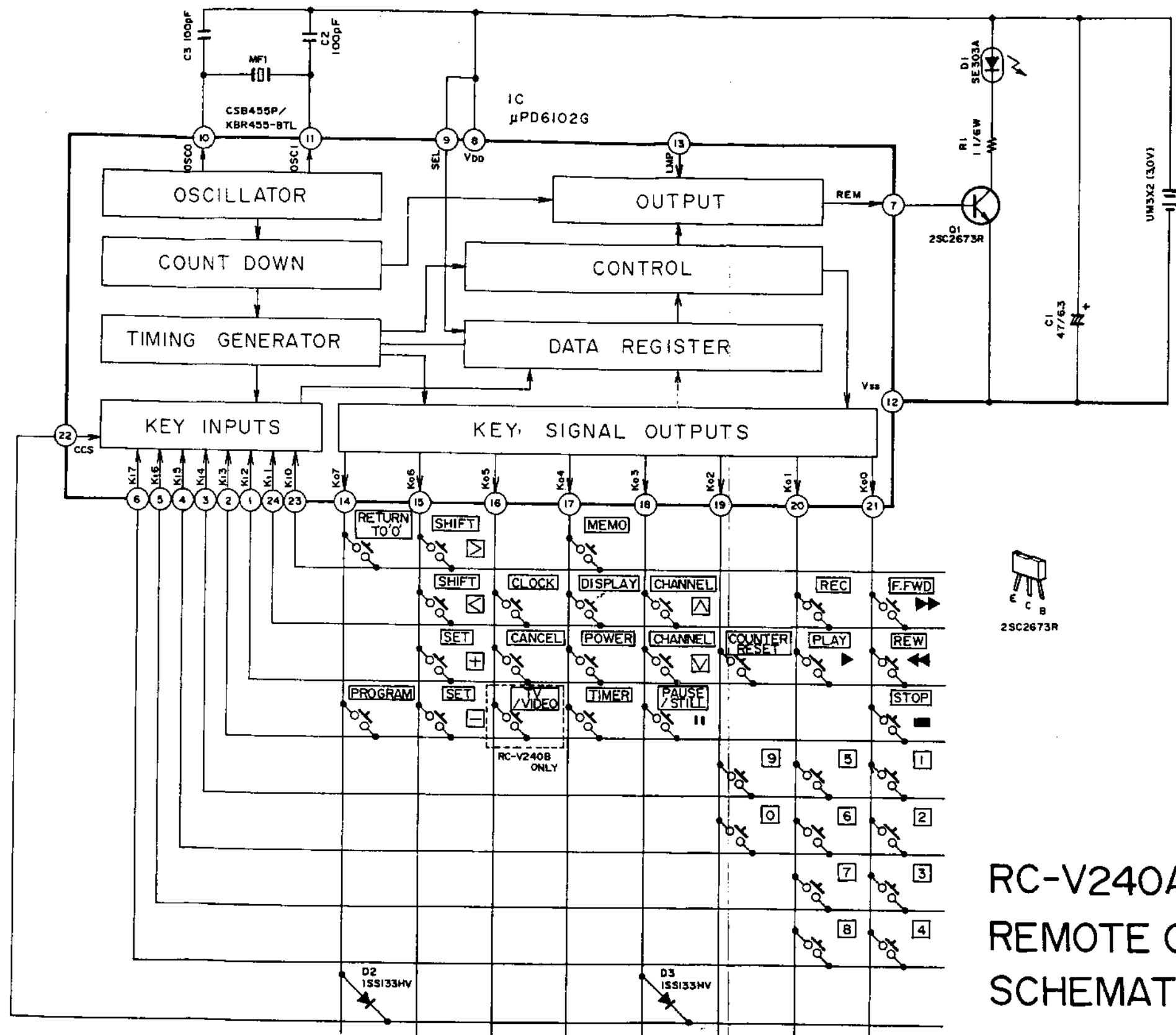

RC-V240A/B
 REMOTE CONTROL UNIT
 SCHEMATIC DIAGRAM

NO.4-4 870232A