



STEREO RECEIVER

MODEL AA-940

ALSO APPLICABLE TO MODEL AA-930 & AA-920

STEREO RECEIVER

SECTION 1	SERVICE MANUAL	3
SECTION 2	PARTS LIST	49
SECTION 3	SCHEMATIC DIAGRAM	80

SECTION 1

SERVICE MANUAL

TABLE OF CONTENTS

I.	SPECIFICATIONS	4
II.	DISMANTLING OF UNIT	6
III.	ARRANGEMENT OF MAIN PARTS	7
IV.	NECESSARY MEASURING INSTRUMENTS	8
V.	CLASSIFICATION OF VARIOUS AMP. P.C. BOARDS	9
VI.	FM TUNER SECTION ADJUSTMENTS	10
	1. FM IF CIRCUIT ADJUSTMENT	10
	2. FRONT END FM IF MATCHING ADJUSTMENT	14
	3. TRACKING ADJUSTMENT	15
	4. SENSITIVITY ADJUSTMENT	15
	5. SIGNAL METER SENSITIVITY ADJUSTMENT	16
	6. STEREO SEPARATION ADJUSTMENT	16
	7. TUNING METER CENTER ADJUSTMENT	16
	8. MUTING LEVEL ADJUSTMENT (STEREO INDICATOR SENSITIVITY ADJUSTMENT)	16
VII.	AM TUNER SECTION ADJUSTMENTS	20
	1. AM IF CIRCUIT ADJUSTMENT	20
	2. TRACKING ADJUSTMENT	21
	3. SENSITIVITY ADJUSTMENT	21
VIII.	POWER AMPLIFIER ADJUSTMENTS	24
	1. POWER AMP. NON-INPUT CURRENT ADJUSTMENT	24
	2. ZERO ELECTRICAL POTENTIAL ADJUSTMENT	24
IX.	POWER AMPLIFIER ADJUSTMENTS (AA-920 ONLY)	26
	1. POWER AMP. NON-INPUT CURRENT ADJUSTMENT	26
	2. VOLTAGE ADJUSTMENT BETWEEN POWER TRANSISTORS C-E	26
X.	TUNING CORD THREADING	30
XI.	COMPOSITE VIEWS OF COMPONENTS	33

I. SPECIFICATIONS

An asterisk next to a figure indicates the minimum guaranteed performance.

§ AMPLIFIER SECTION

		AA-940	AA-930	AA-920
OUTPUT		75Wx2 *66Wx2 at 8Ω distortion 0.5%	50Wx2 *45Wx2 at 8Ω distortion 0.5%	32Wx2 *30Wx2 at 8Ω distortion 1%
FREQUENCY RESPONSE	PHONO AUX	R1AA±1.5 dB 20 Hz-1±3 dB 50 kHz-1 ⁺¹ ₋₂ dB	R1AA±1.5 dB 20 Hz-1±3 dB 50 kHz-1 ⁺¹ ₋₂ dB	R1AA±1.5 dB 20 Hz 0±3 dB 50 kHz-1 ⁺¹ ₋₂ dB
POWER BAND WIDTH		10 to 50,000 Hz distortion 0.5%	10 to 50,000 Hz distortion 0.5%	20 to 50,000 Hz distortion 1%
INPUT SENSITIVITY	PHONO MIC AUX TAPE	2.8 mV(-49±1.5 dB) 2 mV(-52±1.5 dB) 140 mV(-15±1.5 dB) 140 mV(-15±1.5 dB)	2.2 mV(-51±1.5 dB) 1.5 mV(-54±1.5 dB) 110 mV(-17±1.5 dB) 110 mV(-17±1.5 dB)	2.5 mV(-50±1.5 dB) 2.5 mV(-50±1.5 dB) 140 mV(-15±1.5 dB) 140 mV(-15±1.5 dB)
S/N RATIO	PHONO MIC AUX TAPE	Better than -33 dBm Better than -33 dBm Better than -43 dBm Better than -43 dBm	Better than -33 dBm Better than -33 dBm Better than -43 dBm Better than -43 dBm	Better than -35 dBm Better than -35 dBm Better than -45 dBm Better than -45 dBm
RESIDUAL NOISE		Less than 2.5 mV (Less than -50 dBm)	Less than 2.5 mV (Less than -50 dBm)	Less than 1.4 mV (Less than -55 dBm)
TONE CONTROL	BASS TREBLE	10±1.5 dB at 100 Hz -10±1.5 dB at 100 Hz 10±1.5 dB at 10 kHz -10±1.5 dB at 10 kHz	10±1.5 dB at 100 Hz -10±1.5 dB at 100 Hz 10±1.5 dB at 10 kHz -10±1.5 dB at 10 kHz	10±1.5 dB at 100 Hz -10±1.5 dB at 100 Hz 10±1.5 dB at 10 kHz -10±1.5 dB at 10 kHz
LOUDNESS CONTROL		7±1.5 dB at 100 Hz 5±1.5 dB at 10 kHz	7±1.5 dB at 100 Hz 6±1.5 dB at 10 kHz	9±1.5 dB at 100 Hz 6±1.5 dB at 10 kHz
FILTER	LOW CUT FILTER HIGH CUT FILTER	-6±1.5 dB at 50 Hz -9±1.5 dB at 10 kHz	-9±1.5 dB at 50 Hz -9±1.5 dB at 10 kHz	-8±1.5 dB at 50 Hz -9±1.5 dB at 10 kHz
AUDIO MUTE		-21±1.5 dB at 1 kHz	-20±1.5 dB at 1 kHz	
CROSS TALK		Better than 50 dB PHONO 1 kHz	Better than 50 dB PHONO 1 kHz	Better than 50 dB PHONO 1 kHz
L-R DEVIATION		Within 2 dB PHONO	Within 2 dB PHONO	Within 2.5 dB PHONO
RECORDING OUTPUT	PIN DIN	150 mV(-14±2 dB) 30 mV(-28±2 dB)	125 mV(-16±2 dB) 23 mV(-30±2 dB)	140 mV(-15±2 dB) 25 mV(-30±2 dB)

§ FM TUNER SECTION

FREQUENCY RANGE		J 75 to 91±1 MHz U 86 to 109±1 MHz	J 75 to 91±1 MHz U 86 to 109±1 MHz	J 75.4 to 91±1 MHz U 86.8 to 109.2±1 MHz
DIAL TRACKING ERROR		±250 kHz	±250 kHz	±250 kHz
SENSITIVITY (IHF)		1.7 μV *2.8 μV	1.8 μV *2.8 μV	1.9 μV *3.2 μV
SENSITIVITY DEVIATION		Within 3 dB	Within 3 dB	Within 3 dB
IMAGE REJECTION RATIO		J Better than 90 dB U Better than 85 dB	J,U Better than 85 dB	80 dB *J,U Better than 75 dB
IF REJECTION RATIO		J, U Better than 100 dB	J,U Better than 100 dB	100 dB *J,U Better than 85 dB
CAPTURE RATIO (IHF)		1 dB *Less than 1.5 dB	Less than 1.5 dB	Less than 2.5 dB
LIMITING SENSITIVITY		Less than 8 dB	Less than 8 dB	Less than 8 dB
MUTING SENSITIVITY		20±3 dB	20±3 dB	23±3 dB
SELECTIVITY		Better than 80 dB	Better than 80 dB	Better than 70 dB
AM SUPPRESSION RATIO		Better than 45 dB	Better than 45 dB	Better than 45 dB
S/N RATIO	STEREO MONAURAL	70 dB *Better than 50 dB *Better than 60 dB	70 dB *Better than 50 dB *Better than 60 dB	70 dB *Better than 50 dB *Better than 60 dB
DISTORTION FACTOR	STEREO MONAURAL	0.6% *Less than 1.5% 0.2% *Less than 0.5%	0.6% *Less than 1.5% 0.2% *Less than 0.5%	0.7% *Less than 1.5% 0.4% *Less than 0.7%
FREQUENCY RESPONSE		J -13±1 dB at 10 kHz U -11±1 dB at 10 kHz	J -13±1 dB at 10 kHz U -11±1 dB at 10 kHz	J -13±1 dB at 10 kHz U -11±1 dB at 10 kHz
STEREO SENSITIVITY		Less than 20 μV (Less than 26 dB)	Less than 20 μV (Less than 26 dB)	14 μV(23±3 dB)

STEREO INDICATOR SENSITIVITY	Less than 20 μ V (Less than 26 dB)	Less than 20 μ V (Less than 26 dB)	Less than 32 μ V (Less than 30 dB)
STEREO SEPARATION	40 dB *Better than 35 dB	40 dB *Better than 35 dB	40 dB *Better than 33 dB
REJECTION RATIO	Better than 50 dB	Better than 50 dB	Better than 50 dB
L-R DEVIATION	Within 3 dB	Within 3 dB	Within 3 dB
RECORDING OUTPUT	PIN 440 mV(-5 \pm 2 dB) DIN 80 mV (-20 \pm 2 dB)	390 mV(-6 \pm 3 dB) 70 mV(-21 \pm 3 dB)	350 mV(-7 \pm 3 dB) 70 mV(-21 \pm 3 dB)
§ AM TUNER SECTION			
FREQUENCY RANGE	525 \pm 5 kHz to 1,650 \pm 20 kHz	525 \pm 5 kHz to 1,650 \pm 20 kHz	525 \pm 5 kHz to 1,650 \pm 20 kHz
DIAL TRACKING ERROR	Within 5%	Within 2%	Within 2%
SENSITIVITY (IHF)	250 μ V	250 μ V	250 μ V
SENSITIVITY DEVIATION	Within 6 dB	Within 6 dB	Within 6 dB
IMAGE REJECTION RATIO	85 dB *Better than 60 dB at 1 MHz	80 dB *Better than 60 dB at 1 MHz	80 dB *Better than 55 dB at 1 MHz
IF REJECTION RATIO	80 dB *Better than 60 dB at 1 MHz	75 dB *Better than 60 dB at 1 MHz	70 dB *Better than 55 dB at 1 MHz
SELECTIVITY	35 dB *Better than 30 dB \pm 10 kHz	35 dB *Better than 30 dB \pm 10 kHz	Better than 30 dB \pm 10 kHz
S/N RATIO	50 dB *Better than 40 dB	50 dB *Better than 40 dB	50 dB *Better than 40 dB
DISTORTION FACTOR	0.8% *Less than 1.5%	0.8% *Less than 1.5%	0.8% *Less than 1.5%
FREQUENCY RESPONSE	-15 dB at 3 kHz	-15 dB at 3 kHz	-15 dB at 3 kHz
RECORDING OUTPUT	PIN 140 mV(-15 \pm 2 dB) DIN 27 mV(-29 \pm 2 dB)	140 mV(-15 \pm 2 dB) 27 mV(-29 \pm 2 dB)	140 mV(-15 \pm 2 dB) 27 mV(-29 \pm 2 dB)
§ OTHER			
TRANSISTORS	2SA640(L)(M) ... 2 2SA641(L)(M) ... 1 2SA747(O)(Y) ... 2 2SC711(E)(F) ... 8 2SC922(L) ... 2 2SC983(O)(Y) ... 2 2SC1124(1)(2) ... 6 2SD313(E)(F) ... 2 2SA640(1)(P)(Q)(R) ... 4 2SA706-5(1)(2) ... 2 2SC495(O)(Y) ... 1 2SC839(H) ... 4 2SC945(Q)(R) ... 2 2SC1116(O)(Y) ... 2 2SC1312(F)(G) ... 14	2SA640(L)(M) ... 2 2SA641(L)(M) ... 1 2SA747(O)(Y) ... 2 2SC711(E)(F) ... 8 2SC922(L) ... 2 2SC983(O)(Y) ... 2 2SC1124(1)(2) ... 6 2SD313(E)(F) ... 2 2SA640(1)(P)(Q)(R) ... 4 2SA706-4(1)(2) ... 2 2SC495(O)(Y) ... 1 2SC839(H) ... 4 2SC945(Q)(R) ... 3 2SC1116(O)(Y) ... 2 2SC1312(F)(G) ... 12	2SA706-3(1)(2) ... 2 2SC711(E)(F) ... 7 2SC922(L) ... 2 2SC1111(O)(Y) ... 4 2SC1312(G) ... 10 2SA725(G) ... 2 2SC839(H) ... 4 2SC945(Q)(R) ... 1 2SC1124(1)(2) ... 4 2SD313(D)(E) ... 2
F.E.T.	2SK30 (Y) (GR) ... 1	2SK30 (Y) (GR) ... 1	2SK30 (A) (GR) ... 2 2SK30 (Y) (GR) ... 1
I.C.	LA1221 ... 4 LA3300 ... 1	LA1221 ... 4 LA3300 ... 1	LA1221 ... 4 LA3300 ... 1
DIODES	1N34A ... 7 1N60P ... 2 1OD1 ... 1 1N60 ... 5 WG599 ... 1 1OD2 ... 10 SR3AM-8 ... 4	1N34A ... 7 1N60P ... 2 1OD1 ... 1 1N60 ... 5 WG599 ... 1 1OD2 ... 10 SR3AM-8 ... 4	1N34A ... 7 1N60P ... 2 1OD1 ... 1 1N60 ... 5 WG599 ... 1 SR3AM-4 ... 4
ZENER DIODES	WZ130 ... 5	WZ130 ... 5	WZ130 ... 1
VARISTORS	STV-4H ... 2	STV-4H ... 2	STV-3H ... 2
POWER SOURCE	100 to 240V 50/60 Hz 220V 50 Hz(WG)	100 to 240V 50/60 Hz 220V 50 Hz(WG)	100 to 240V 50/60 Hz 220V 50 Hz(WG & CEE) 120V 60 Hz(CSA)
POWER CONSUMPTION	MAX, 360W/440VA(4 Ω) 1/3, 140W/165VA(4 Ω)	MAX, 260W/320VA(4 Ω) 1/3, 130W/155VA(4 Ω)	180W
DIMENSIONS	483(W)x168(H)x398(D) mm (19"x6.6"x15.7")	483(W)x168(H)x398(D) mm (19"x6.6"x15.7")	454(W)x155(H)x330(D) mm (17.9"x6.1"x13")
WEIGHT	15.5 kg (34.1 lbs.)	15 kg (33 lbs.)	15 kg (33 lbs.)

NOTE: Specifications subject to change without notice.

II. DISMANTLING OF UNIT

In case of trouble, etc. necessitating disassembly, please disassemble in the order shown in photographs. Reassemble in reverse order.

1

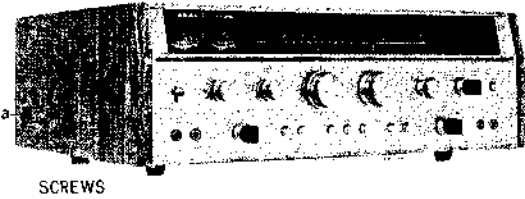

2

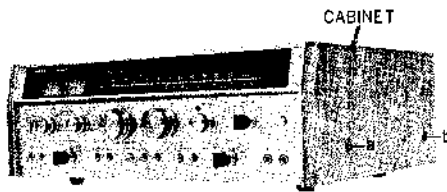

3

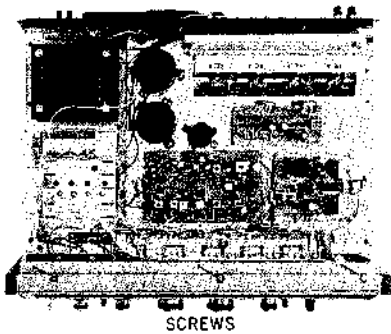

4

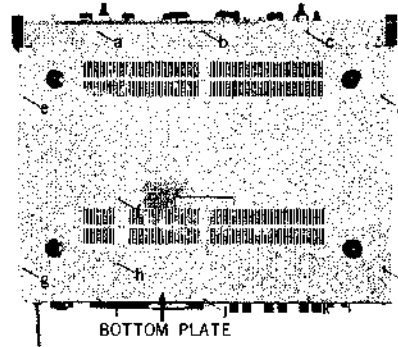

5

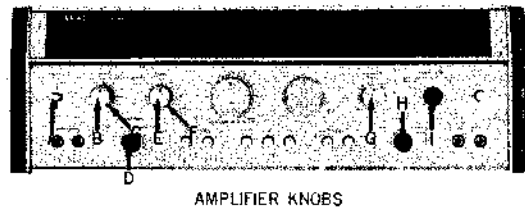

6

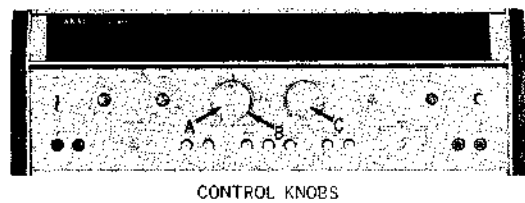

7

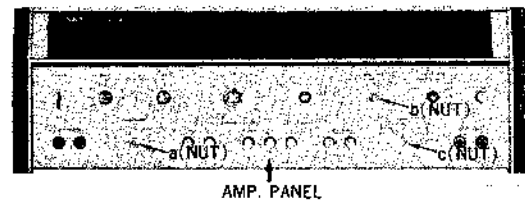

III. ARRANGEMENT OF MAIN PARTS

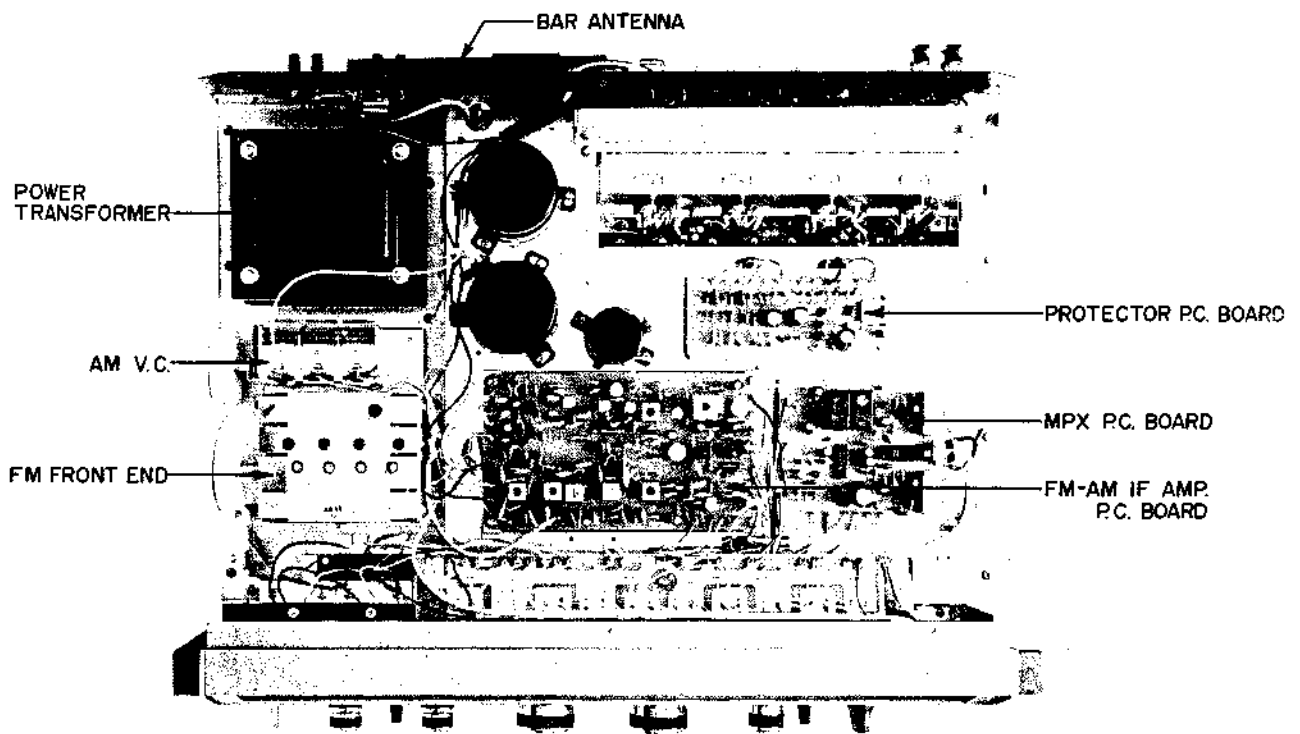

Fig. 1

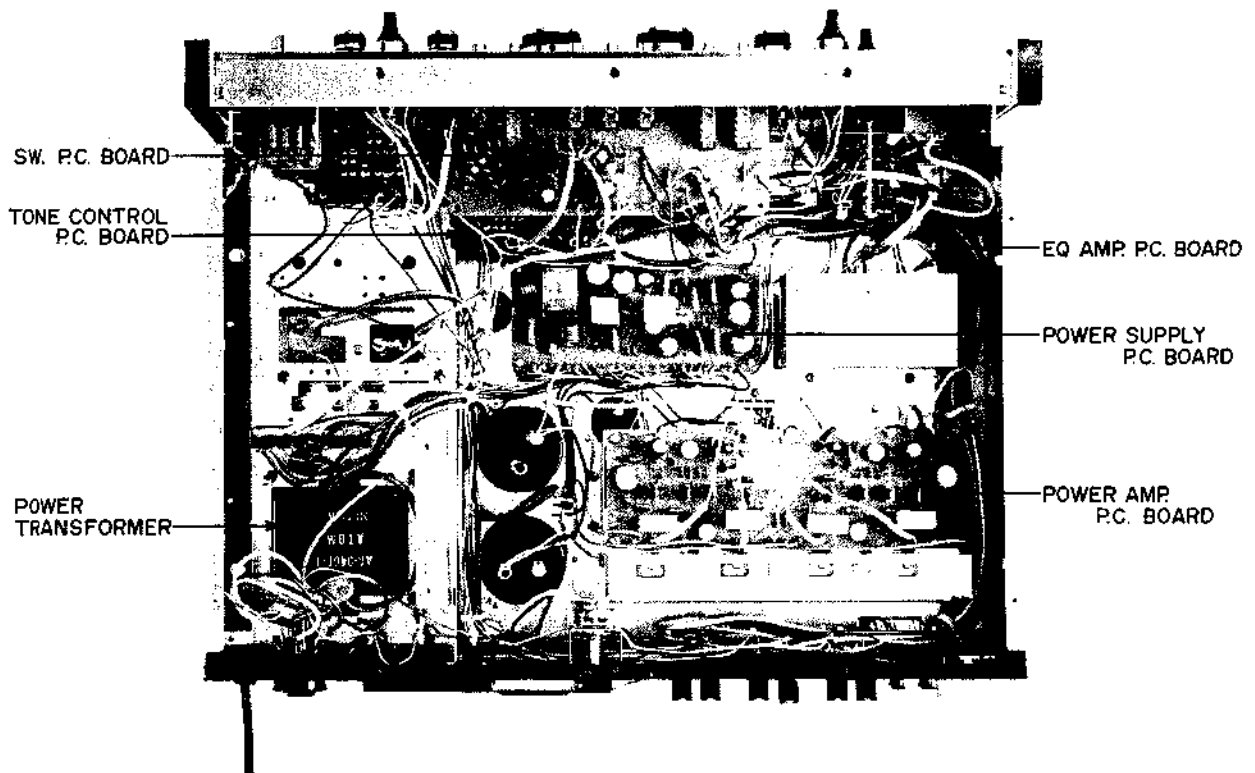

Fig. 2

IV. NECESSARY MEASURING INSTRUMENTS

(For Adjustment of Models AA-940, AA-930, and AA-920)

Measuring Instrument	Model	For
AM-FM Radio IF Genescope	Meguro MSW-721C	FM and AM IF Adjustment
FM Standard Signal Generator	Meguro MSG-278G	FM Tracking, Sensitivity Adjustment
FM Stereo Modulator	Meguro MSG-211E	Stereo Separation Adjustment
AM Standard Signal Generator	Meguro MSG-221C	AM Tracking, Sensitivity Adjustment
AM Loop Antenna	Meguro MLA-1001B	AM Tracking, Sensitivity Adjustment
High Sensitivity V.T.V.M.	Kikusui 183E	Sensitivity, Stereo Separation Adjustment
Distortion Meter	Shibasoku 760C	Sensitivity Adjustment
Ampere Meter	Yokogawa 2011	Power Amp. Adjustment

Chart 1

V. CLASSIFICATION OF VARIOUS AMP. P. C. BOARDS

(Employed in Models AA-940, AA-930, and AA-920)

P.C. Board	AA-940	AA-930	AA-920
MPX P.C. BORD	94-5008	94-5008	94-5008
FM-AM IF AMP. P.C. BOARD	94-5009	94-5009	94-5009
PROTECTOR P.C. BOARD	94-5010	94-5010	
POWER SUPPLY P.C. BOARD	94-5011	94-5011	92-5004
EQ. AMP. P.C. BOARD	94-5012	94-5012	92-5003
POWER AMP. P.C. BOARD	94-5013	94-5013	92-5005
SWITCH P.C. BOARD	94-5020	93-5005	92-5011
TONE CONTROL P.C. BOARD	94-5025	94-5025	92-5010
DIAL ILLUMINATION P.C. BOARD	AA-5029	AA-5029	91-5035
DIMMER SW. P.C. BOARD	94-5023		
HEADPHONE P.C. BOARD	94-5022	94-5022	94-5022
MIC P.C. BOARD	94-5021	94-5021	94-5021

Chart 2

VI. FM TUNER SECTION ADJUSTMENTS

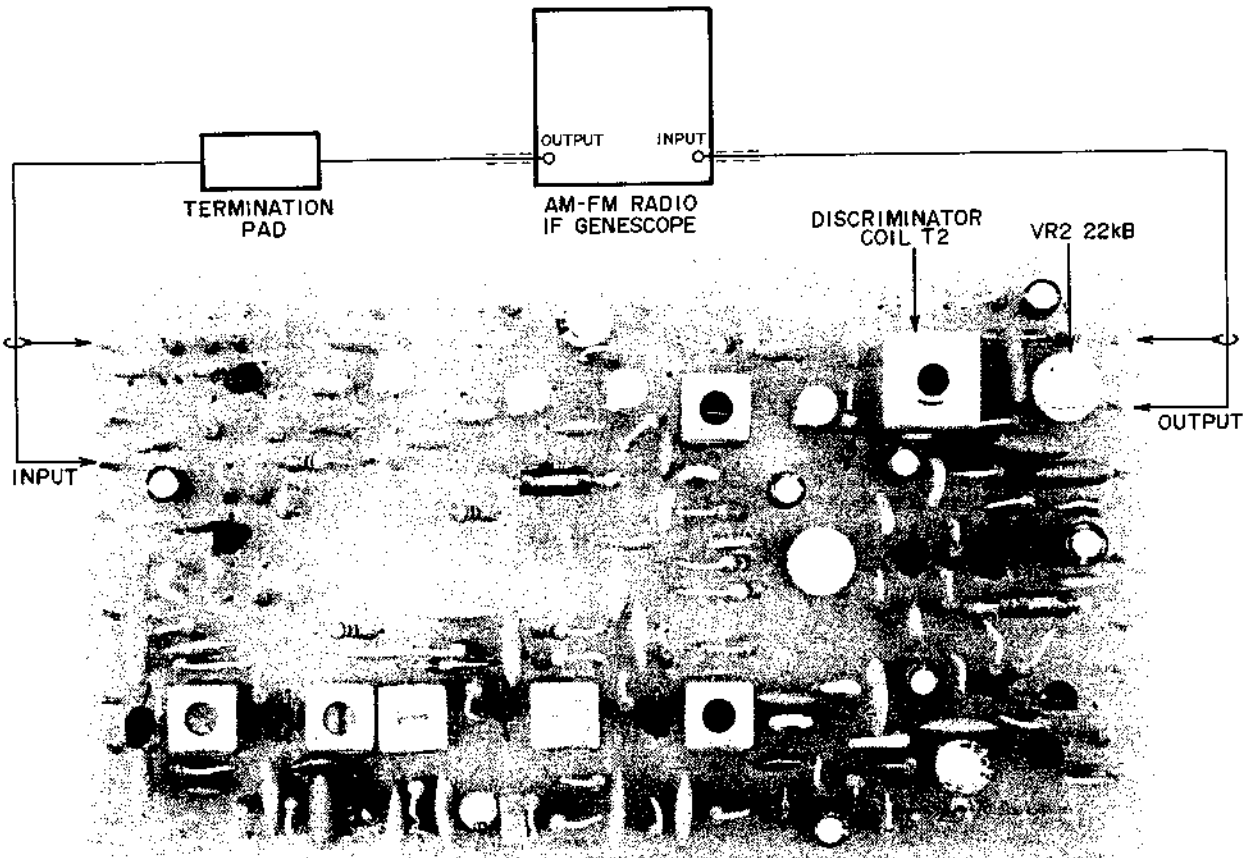

Fig. 3 INSTRUMENT CONNECTIONS

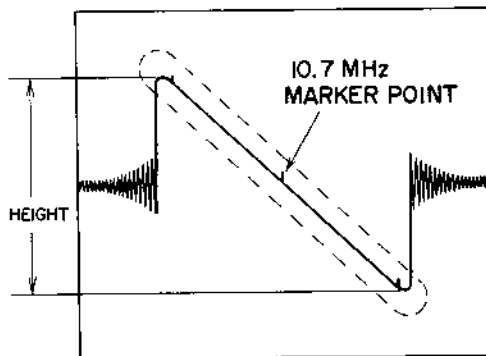

Fig. 4

Vertical Gain	0.3V _{p-p} to 1 cm
GENESCO Output Level	50 dB
Discriminator Coil	T2
S Curve Height	5 cm

Chart 3

1. FM IF CIRCUIT ADJUSTMENT

- 1) Connect the lead wires from an AM-FM Radio IF GENESCOPE (hereinafter referred to as GENESCO) to the input as well as the output of the FM-AM IF Amp. P.C. Board as shown in Fig. 3.
- 2) Set GENESCO to FM mode and adjust vertical gain (refer to Chart 3).
- 3) Set Receiver SELECTOR to FM AUTO, and tuning indicator needle to extreme right end of the dial. At this time confirm that a noise element does not enter the S Curve shown in Fig. 4.
- 4) Adjust output level of GENESCO (refer to Chart 3).
- 5) Manually center FM-AM IF Amp. P.C. Board semi-fixed resistor VR2 22 kΩ.
- 6) Adjust the upper and lower cores of Discriminator Coil so that the wave height value of the S Curve shown in Fig. 4 is maximum and the linearity of the part indicated by the dotted line is optimum. (Refer to Fig. 4 and Chart 3)

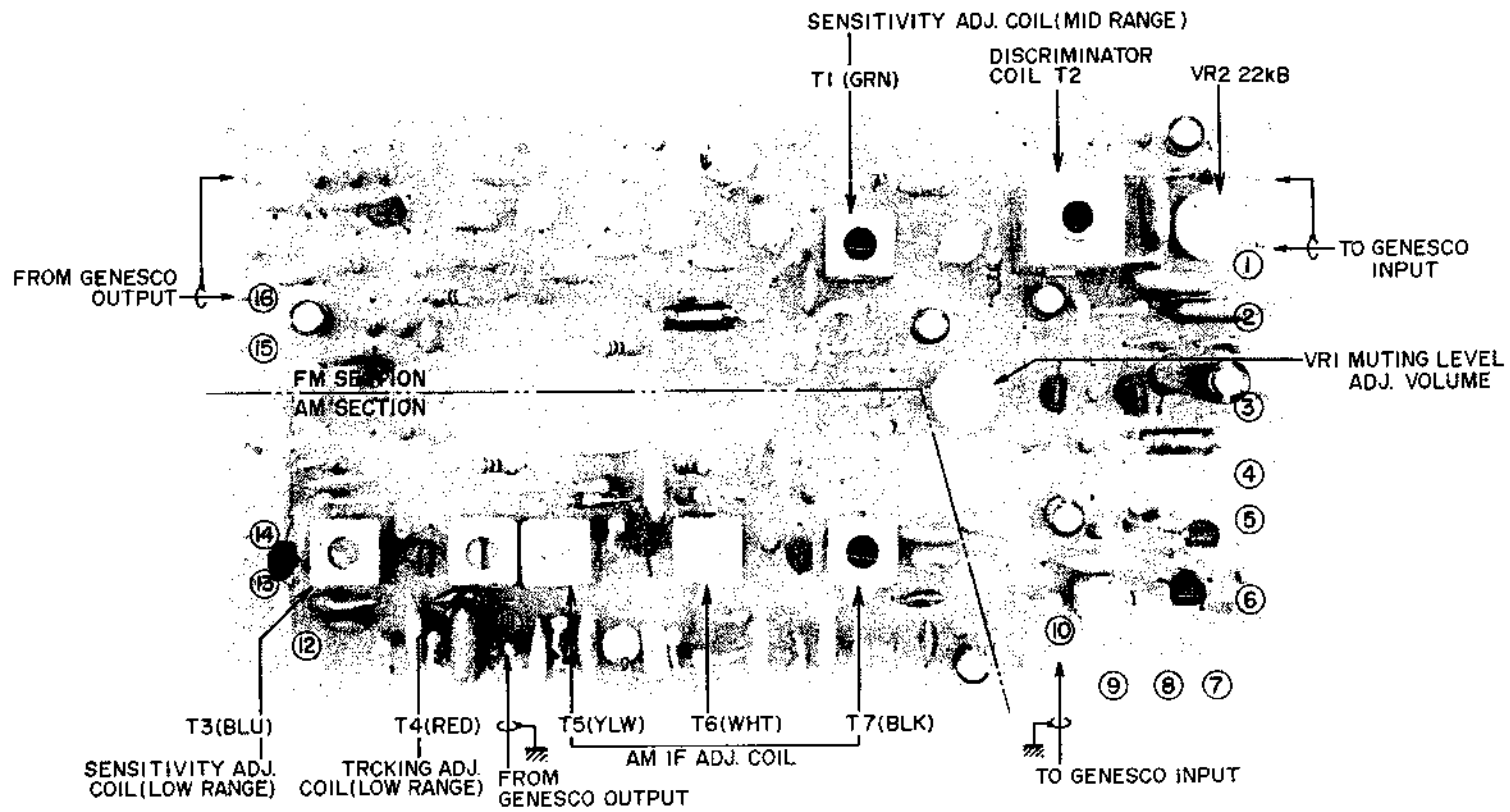

Fig. 5 FM-AM IF AMP. P.C. BOARD 94-5009

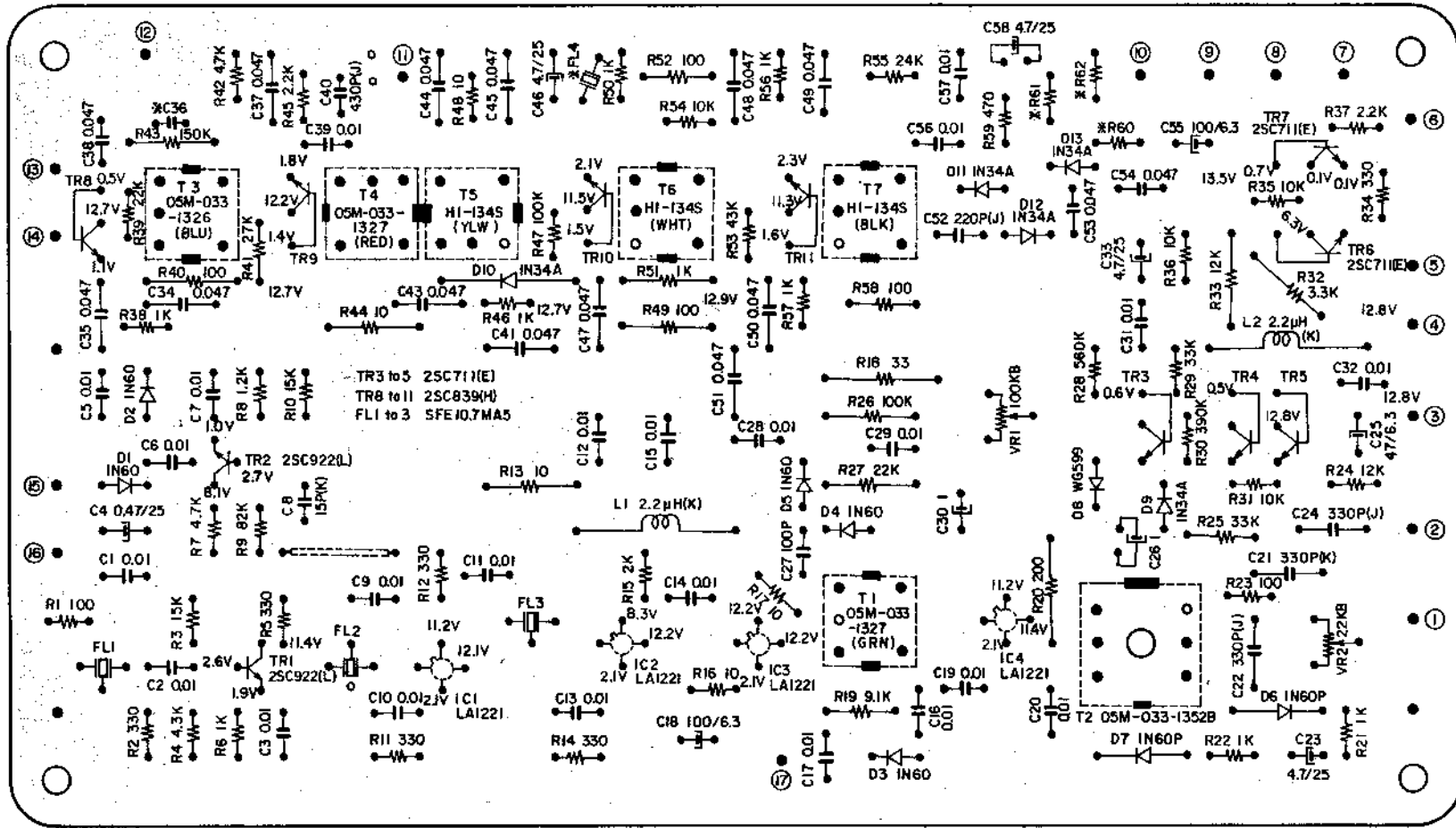
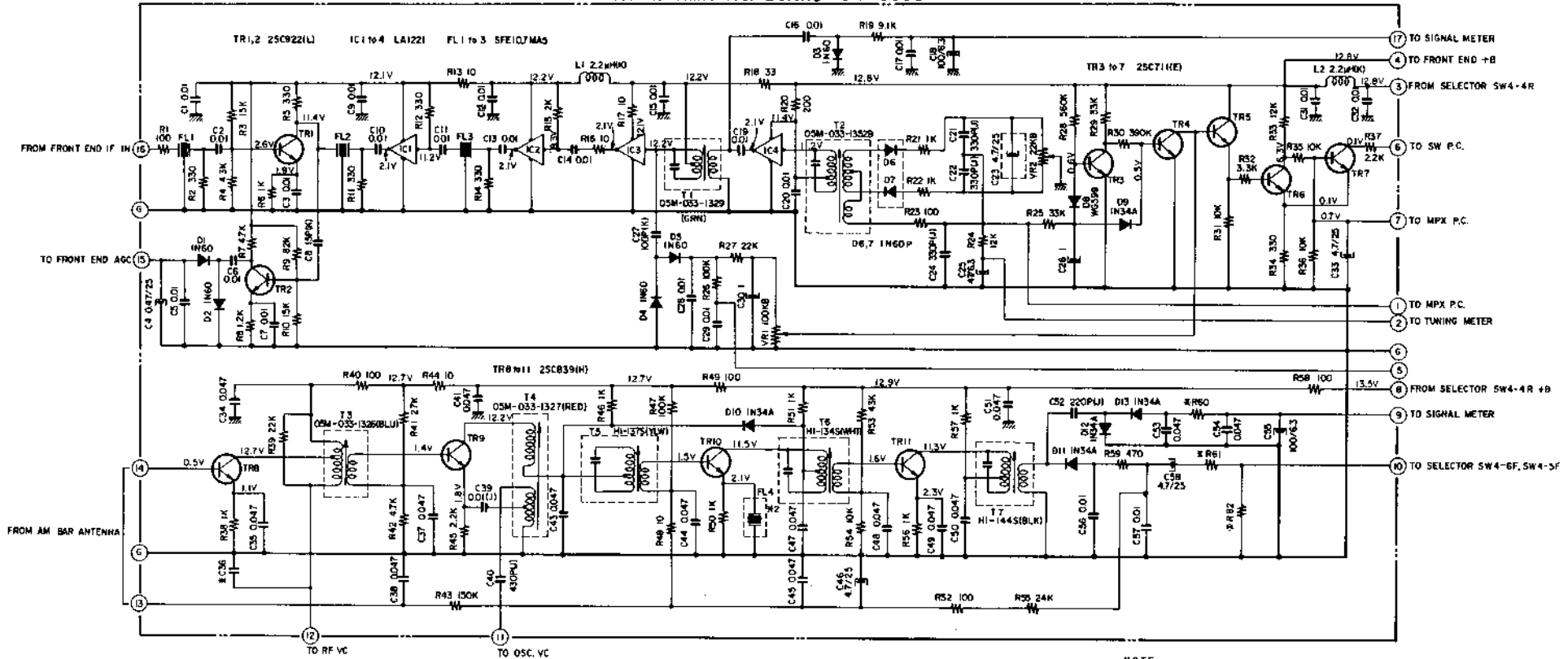

Fig. 6 FM-AM IF AMP. P.C. BOARD 94-5009 (Rev. Side)

FM-AM IF AMP. P.C. BOARD 94-5009



X CAPACITORS LIST

AA-940	AA-930	AA-920
C36	10P (J)	11P (J)

X RESISTORS LIST

AA-940,930	AA-920
R60	15K 32K
R61	91K 120K
R62	2.2K 1K

***2 FL4**

J-A US-A	US-B
BFB 455B-5	BFB 464A

NOTE

UNLESS OTHERWISE SPECIFIED
 ALL RESISTORS IN Ω, 1/4W (J)
 ALL CAPACITORS IN pF 50W.V (Z)

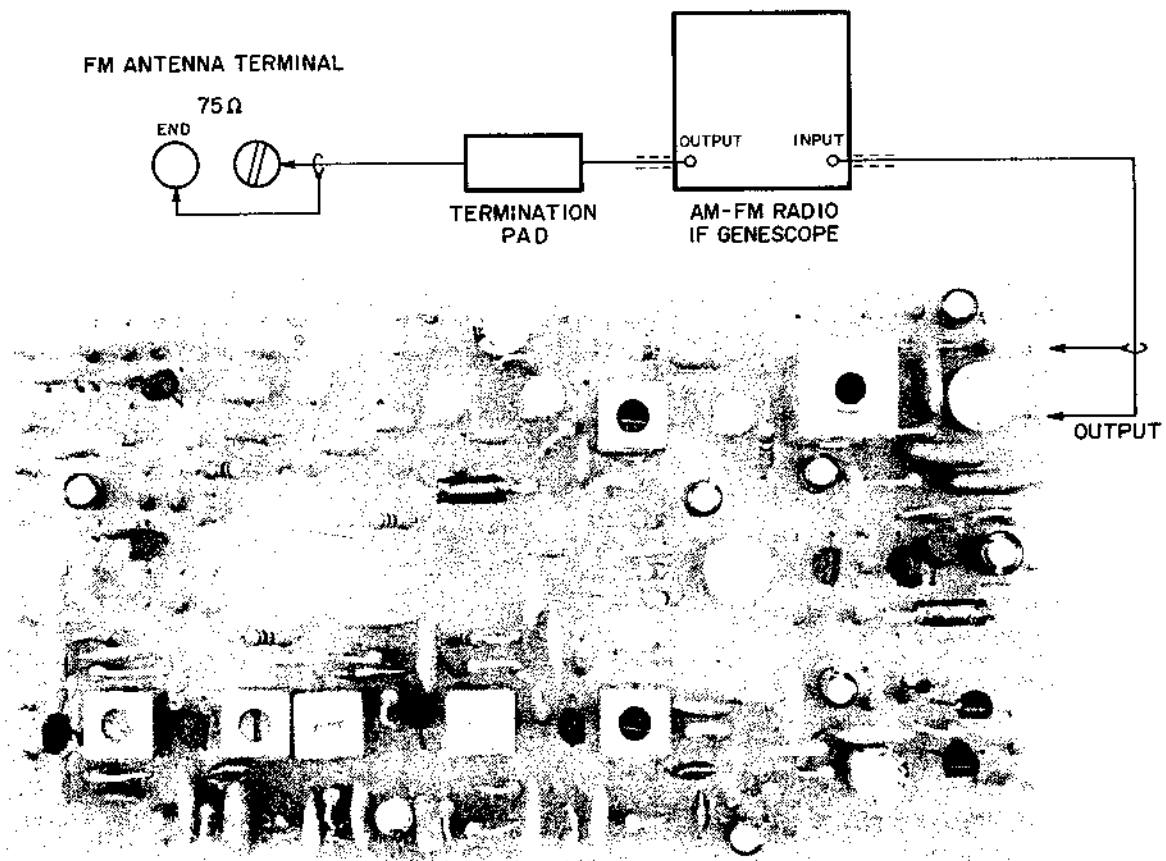

Fig. 7 INSTRUMENT CONNECTIONS

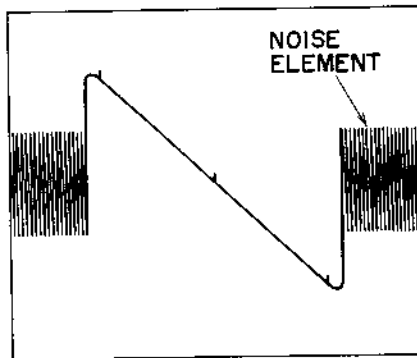

Fig. 8

2. FRONT END AND FM IF MATCHING ADJUSTMENT

- 1) Connect the GENESCOPE lead wires to the 75Ω FM ANTENNA TERMINALS of the Receiver as well as to the FM IF Amp. P.C. Board output as shown in Fig. 7.
- 2) Set the GENESCOPE to FM mode and adjust the vertical gain of GENESCOPE to obtain a 10 mm amplitude of the 0.3Vp-p calibration voltage on GENESCOPE Screen and set the GENESCOPE attenuator to 100 dB.
- 3) Set Receiver SELECTOR to FM AUTO, and tuning indicator needle to extreme right end of the dial.
- 4) Adjust the upper core of Front End IF Coil (see Figs. 18,21) to obtain maximum wave height value of S Curve in Fig. 8, and adjust the lower core to obtain maximum noise level.
- 5) Make this adjustment again following FM Sensitivity Adjustment.

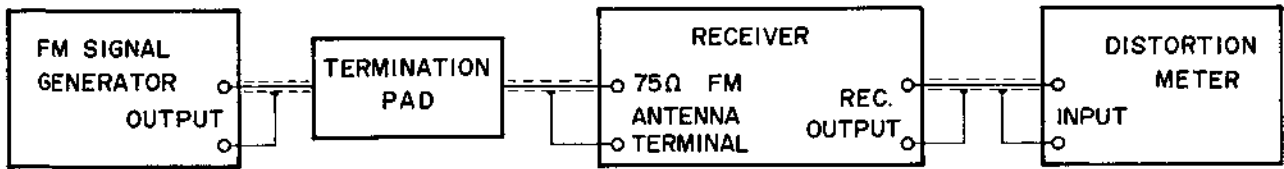

Fig. 9 INSTRUMENT CONNECTIONS

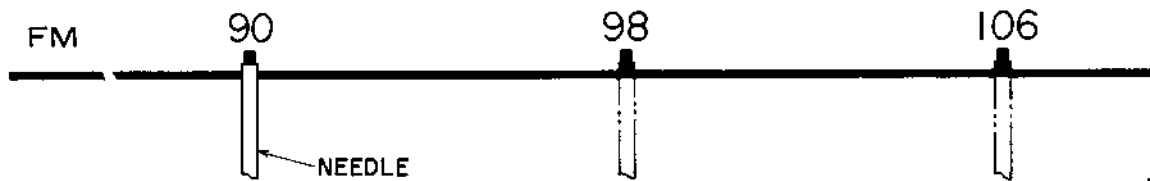

Fig. 10

FM S.G. Output	40 dB
Core (Low Range)	Lo
Trimmer Condenser (High Range)	TCo

Chart 4

Ref. In making Tracking Adjustments, set dial to following positions.

3. TRACKING ADJUSTMENT

- 1) Connect the various measuring instruments as shown in Fig. 9.
- 2) Set the oscillation frequency of the FM SIGNAL GENERATOR (hereinafter referred to FM S.G.) to 90 MHz (400 Hz 100% internal modulation), and set the output of the FM S.G. to 46 dB. (Refer to Chart 4)
- 3) Set Receiver SELECTOR to FM AUTO, and tuning indicator needle to 90 MHz. (Refer to Fig. 10)
- 4) Adjust Core Lo of Front End (Figs. 18,21) until the distortion meter level is maximum and the distortion factor is minimum. (Refer to Chart 4)
- 5) Set the oscillation frequency of FM S.G. and tuning indicator needle to 106 MHz. (Refer to Fig. 10)
- 6) Adjust Trimmer Condenser TCo of Front End (Figs. 18,21) until the distortion meter level is maximum and the distortion factor is minimum. (Refer to Chart 4)

4. SENSITIVITY ADJUSTMENT

- 1) Carry out these adjustments after the previously described Tracking Adjustments have been completed.
- 2) Measuring instrument connections are the same as described in Tracking Adjustments.
- 3) Set the oscillation frequency of the FM S.G. to 90 MHz (400 Hz, 100% internal modulation), set Receiver SELECTOR to FM AUTO, and set the tuning indicator needle to 90 MHz. (Refer to Fig. 10)
- 4) Adjust the FM S.G. Attenuator to obtain a 3% distortion factor.
- 5) Adjust the cores of Front End (Figs. 18,21) until the distortion meter level is maximum and the distortion factor is minimum. (Refer to Chart 5)
- 6) Set the oscillation frequency of FM S.G. and tuning indicator needle to 106 MHz. (Refer to Fig. 10)
- 7) Adjust the FM S.G. Attenuator to obtain a 3% distortion factor.
- 8) Adjust Trimmer Condensers of Front End (Figs. 18,21) until the distortion meter level is maximum and the distortion factor is minimum. (Refer to Chart 5)
- 9) Set the oscillation frequency of FM S.G. and the tuning indicator needle to 98 MHz. (Refer to Fig. 10)
- 10) Adjust the FM S.G. Attenuator to obtain a 3% distortion factor.
- 11) Adjust the upper and lower cores of IF Coil in Front End (Figs. 18,21) and the lower core of FM-AM IF Amp. P.C. Board Discriminator Coil until the distortion meter level is maximum and the distortion factor is minimum. (Refer to Chart 5)
- 12) Repeat adjustments outlined in Items 3) through 11) at 90 MHz, 98 MHz and 106 MHz two or three times for highest sensitivity.

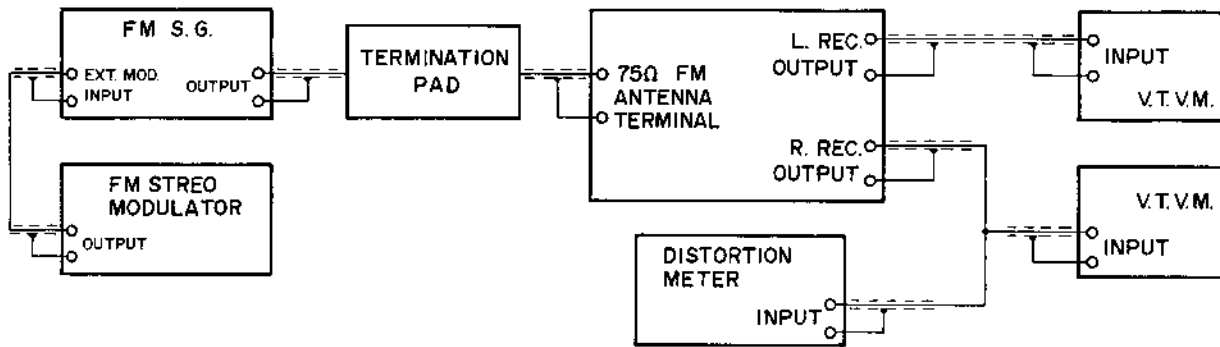

Fig. 11 INSTRUMENT CONNECTIONS

	AA-940	AA-930	AA-920
Core (Low Range)	LR, LR, LA	LR2, LR1, LA	LR2, LR1, LA
Trimmer Condenser (High Range)	TCR, TCR, TCA	TCR2, TCR1, TCA	TCR2, TCR1, TCA
IF Coil (Mid Range)	IF	IF	IF
Discriminator Coil (Mid Range)	T2	T2	T2

Chart 5

5. SIGNAL METER SENSITIVITY ADJUSTMENT

- 1) Supply a 98 MHz (400 Hz, 100% internal modulation) 60 dB signal to the Receiver from the S.G. Alignment is attained when the tuning meter indicator comes to the exact center of the meter.
- 2) Under the above conditions, adjust the core of Coil T1(GRN) of FM-AM IF Amp. P.C. Board to obtain maximum signal meter indication.

6. STEREO SEPARATION ADJUSTMENT

- 1) Connect the various measuring instruments as shown in Fig. 11.
- 2) Set the FM STEREO MODULATOR pilot signal 19 kHz to 10%, and the main signal 400Hz (left channel + right channel) to 90% modulation, and supply this composite signal (ratio 9:1) to the EXT MOD. input terminal of the FM S.G.
- 3) Set the FM S.G. oscillation frequency to 98 MHz, and the Attenuator to 66 dB.
- 4) Set Receiver SELECTOR to FM AUTO, and the tuning indicator needle to 98 MHz to receive the FM S.G. Signal.
- 5) Set the output signal selector of FM STEREO MODULATOR to SUB.
- 6) Adjust the cores of MPX AMP. P.C. Board 19 kHz Filter L1(BLK), and 38 kHz Filter L2(WHT) until the distortion factor is minimum. (Refer to Fig. 12)

- 7) Set the output signal selector of FM STEREO MODULATOR to left channel.
- 8) Adjust the MPX Adjustment Volume located on rear panel of the Receiver until the right channel output level is minimum.

7. TUNING METER CENTER ADJUSTMENT

After completing the adjustments outlined in Parts 1 through 4 of this manual, set the FM S.G. Attenuator to non-output condition, and adjust the upper core of FM-AM IF Amp. P.C. Board Discriminator Coil T2 shown in Fig. 5 until the tuning indicator needle of tuning meter comes to the center. Then set Receiver dial to 98 MHz, supply a 98 MHz (400 Hz, 100% internal modulation) 66 dB signal from the FM S.G., and fine adjust the lower core of Discriminator Coil T2 for minimum distortion factor.

8. MUTING LEVEL ADJUSTMENT (STEREO INDICATOR SENSITIVITY ADJUSTMENT)

- 1) Connect the various measuring instruments as shown in Fig. 11.
- 2) Set the FM S.G. oscillation frequency to 98 MHz (400 Hz 100% internal modulation) and Attenuator to non-output condition.
- 3) Set receiver dial to 98 MHz.
- 4) Adjust FM-AM IF Amp. P.C. Board semi-fixed resistor VR1 68 kB so that when the attenuation decreases and the Attenuator scale is at 26 dB, signal output is emitted at both channels.

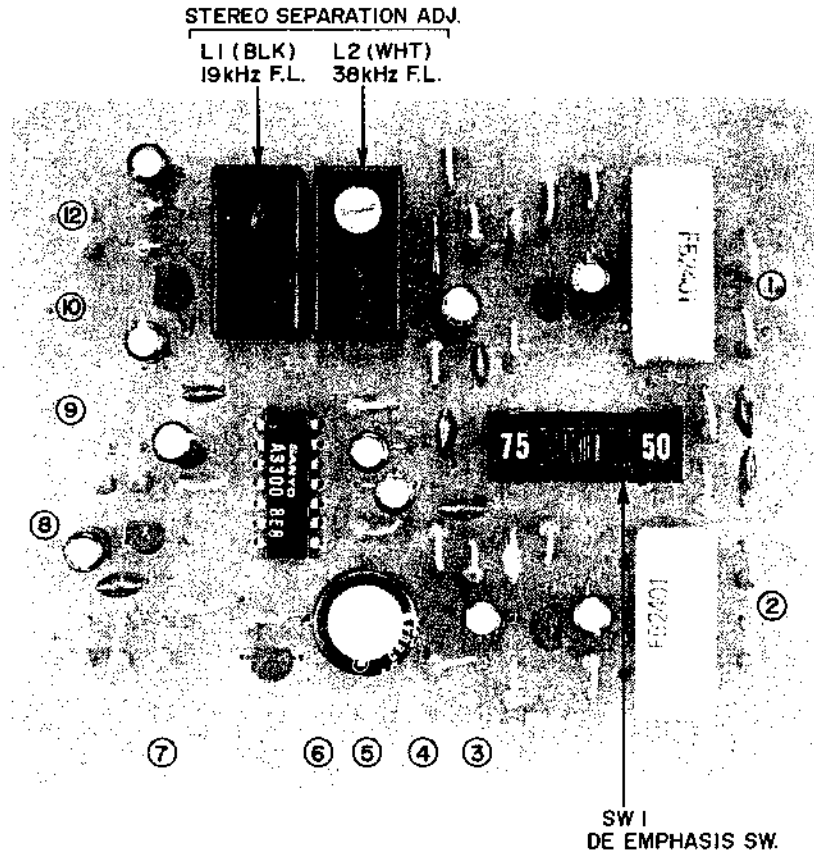
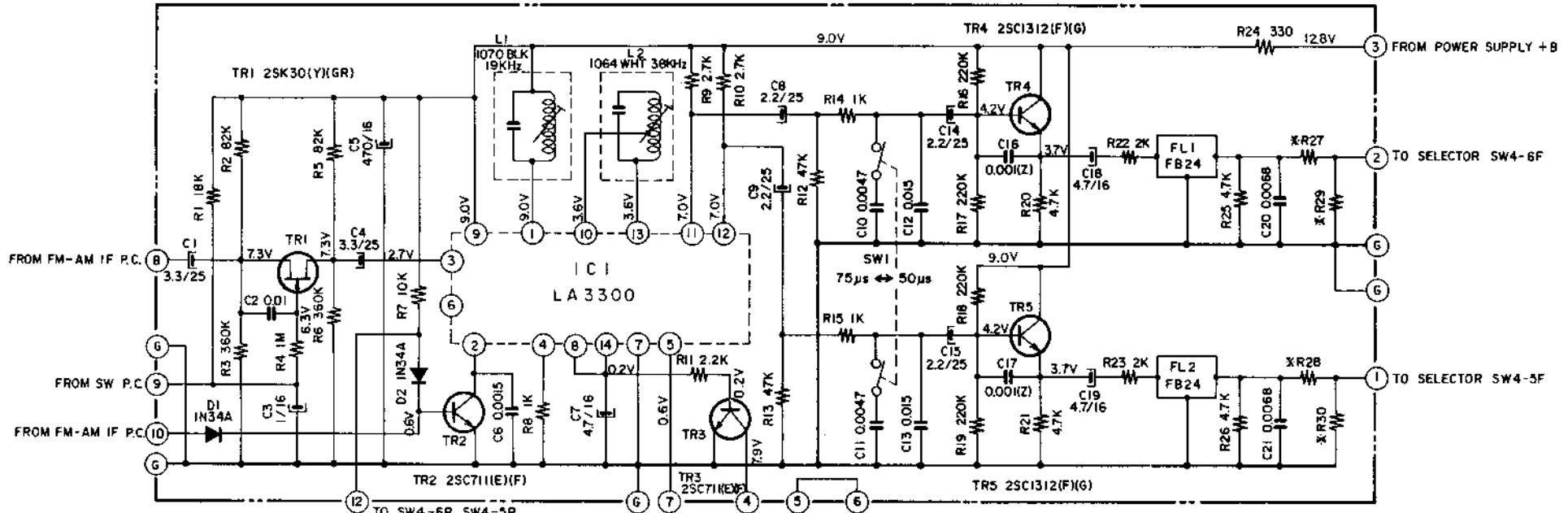

Fig. 12 MPX P.C. BOARD 94-5008

MPX P.C. BOARD 94-5008



	AA-930/940	AA-920
R 27	47K	12K
R 28	47K	12K
R 29	22K	1K
R 30	22K	1K

NOTE
 UNLESS OTHERWISE SPECIFIED
 ALL RESISTORS IN Ω (1/4W)(J)
 ALL CAPACITORS IN μF 50W.V.(J)
 * MARK INDICATE RESISTORS ARE
 DIFFERENT ACCORDING TO MODEL NUMBER

SCHEMATIC 2

VII. AM TUNER SECTION ADJUSTMENTS

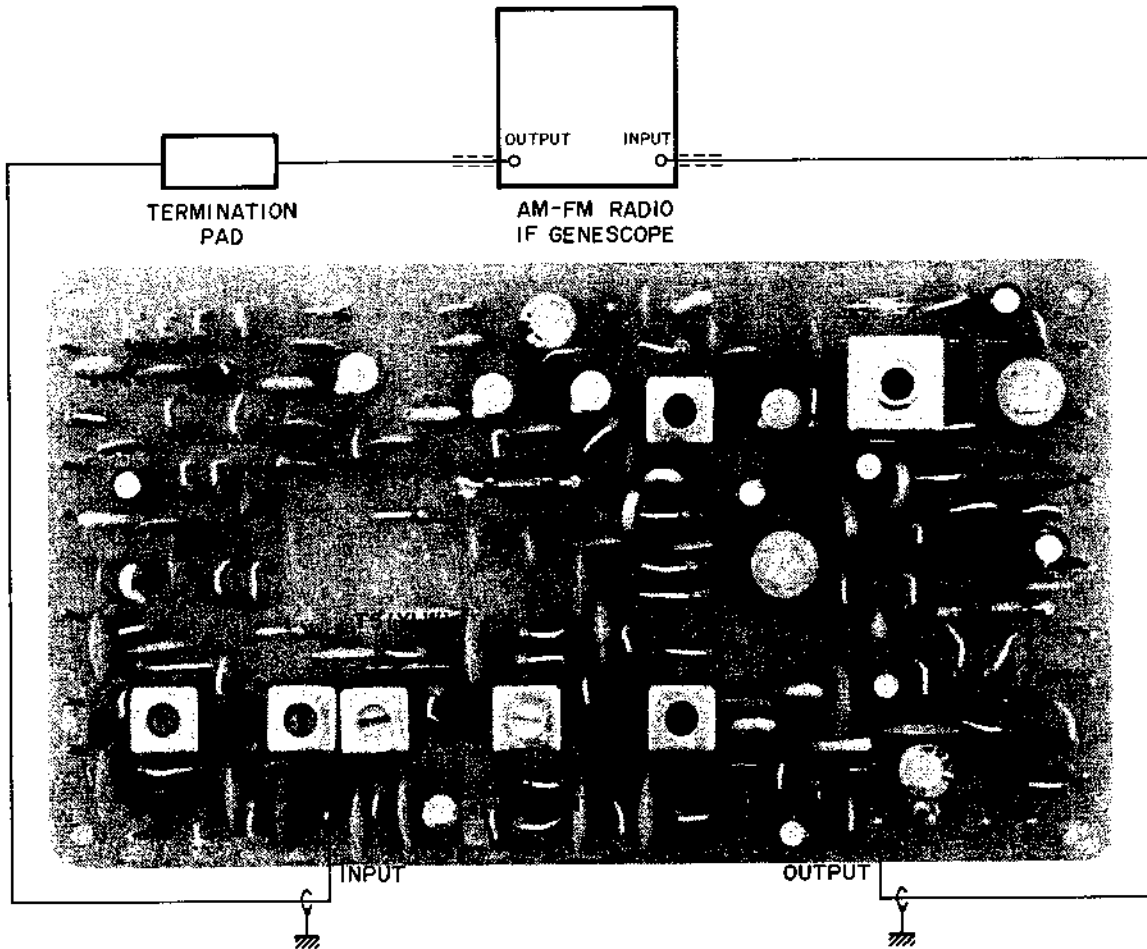

Fig. 14 INSTRUMENT CONNECTIONS

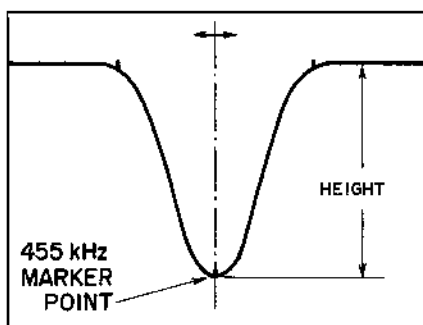

Fig. 15

Vertical Gain	0.3Vp-p to 1 cm
GENESCO Output Level	60 dB
Single Peaked Curve Height	4 cm

Chart 6

1. AM IF CIRCUIT ADJUSTMENT

- 1) Connect the AM-FM Radio IF GENESCO (hereinafter referred to as GENESCO) lead wires to input terminal as well as output terminal of the FM-AM IF Amp. P.C. Board as shown in Fig. 14.
- 2) Set GENESCO to AM mode and adjust vertical gain. (Refer to Chart 6)
- 3) Set Receiver SELECTOR to AM and set the tuning indicator needle to extreme right end of the dial.

NOTE: A noise element should not enter the single peaked curve shown in Fig. 15.

- 4) Adjust output level of GENESCO. (Refer to Chart 6)
- 5) Adjust the cores of FM-AM IF Amp. P.C. Board IFT T7(BLK) (refer to Fig. 5) so that the 455 kHz marker point of the single peaked curve displays maximum amplitude as shown in Fig. 15.
- 6) Adjust the cores of FM-AM IF Amp. P.C. Board IFT T6(WHT) and T5(YLW) (refer to Fig. 5) so that the left and right rise up characteristics of the single peaked curve shown in Fig. 15 are identical from the center (indicated by the dotted line in the figure).
- 7) In making this adjustment the single peaked curve marker point will differ according to the rank of the ceramic filter.

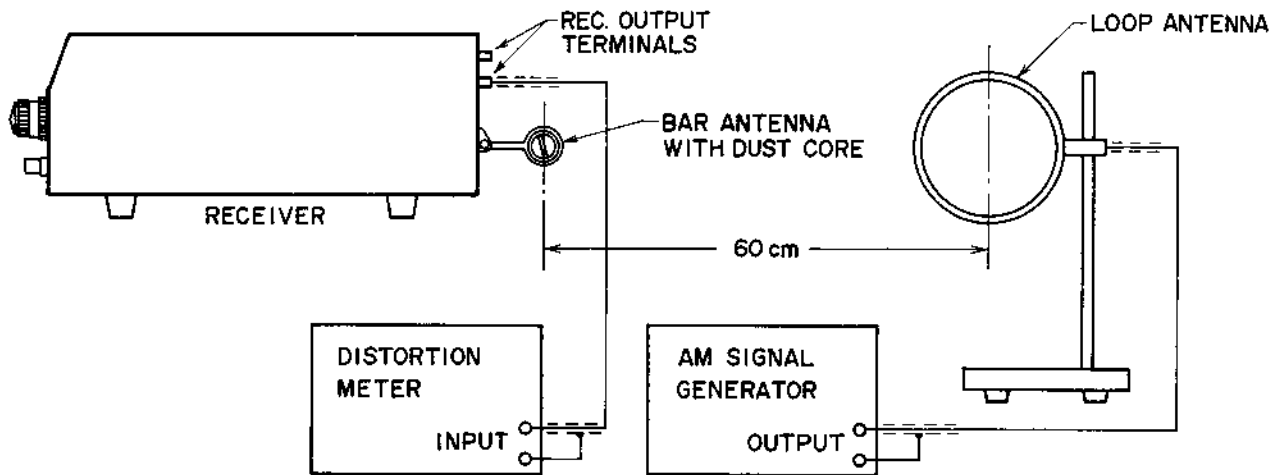

Fig. 16 INSTRUMENT CONNECTIONS

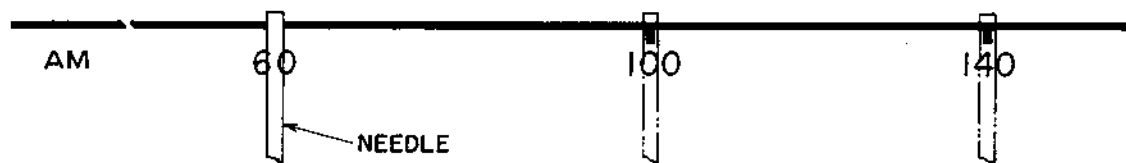

Fig. 17

2. TRACKING ADJUSTMENT

- 1) Connect the various measuring instruments as shown in Fig. 16.
- 2) Set the oscillation frequency of the AM SIGNAL GENERATOR (hereinafter referred to as AM S.G.) to 600 kHz (400 Hz 30% internal modulation) and adjust the AM S.G. Attenuator. (Refer to Chart 7)
- 3) Set Receiver SELECTOR to AM and tuning indicator needle to 600 kHz. (Refer to Fig. 17)
- 4) Adjust the core of FM-AM IF Amp. P.C. Board Tracking Adjustment Coil T4(RED) in Fig. 5 until the distortion meter level is maximum and the distortion factor is minimum.
- 5) Set the oscillation frequency of AM S.G. and tuning indicator needle of Receiver to 1,400 kHz. (Refer to Fig. 17)
- 6) Adjust Front End Trimmer Condenser in Figs. 20,21 until the distortion meter level is maximum and the distortion factor is minimum. (Refer to Chart 7)
- 7) Repeat adjustments outlined in Items 2) through 6) two or three times for minimum tracking error.

3. SENSITIVITY ADJUSTMENT

- 1) Carry out these adjustments after the previously described Tracking Adjustments have been completed.
- 2) Measuring instrument connections are the same as described in Tracking Adjustments. (Refer to Fig. 16)
- 3) Set the oscillation frequency of the AM S.G. to 600 kHz (400 Hz 30% internal modulation). Set Receiver SELECTOR to AM and the tuning indicator needle to 600 kHz. (Refer to Fig. 17)
- 4) Adjust AM S.G. Attenuator to obtain a 10% distortion factor.
- 5) Adjust dust core of Bar Antenna shown in Fig. 16 until the distortion meter level is maximum and the distortion factor is minimum.
- 6) Set the oscillation frequency of AM S.G. and tuning indicator needle of Receiver to 1,400 kHz. (Refer to Fig. 17)
- 7) Adjust AM S.G. Attenuator to obtain a 10% distortion factor.
- 8) Adjust Front End trimmer condensers in Figs. 20, 21 until the distortion meter level is maximum and the distortion factor is minimum. (Refer to Chart 8)

- 9) Set the oscillation frequency of AM S.G. and tuning indicator needle of Receiver to 1,000 kHz. (Refer to Fig. 17)
- 10) Adjust AM S.G. Attenuator to obtain a 10% distortion factor.
- 11) Adjust the core of FM-AM IF Amp. P.C. Board Coil T3(BLU) (refer to Fig. 5) until the distortion meter level is maximum and the distortion factor is minimum.
- 12) Repeat adjustment outlined in Items 3) through 11) at 600 kHz, 1,000 kHz and 1,400 kHz two or three times for highest sensitivity.

AM S.G. Output	60 dB
Core (Low Range)	T4
Trimmer Condenser (High Range)	TC1

Chart 7

Ref. In making Tracking Adjustments, set dial to following positions.

Bar Antenna Dust Core (Low Range)	Fig. 16
Trimmer Condenser (High Range)	TC2, TC3
RF Coil (Mid Range)	T3

Chart 8

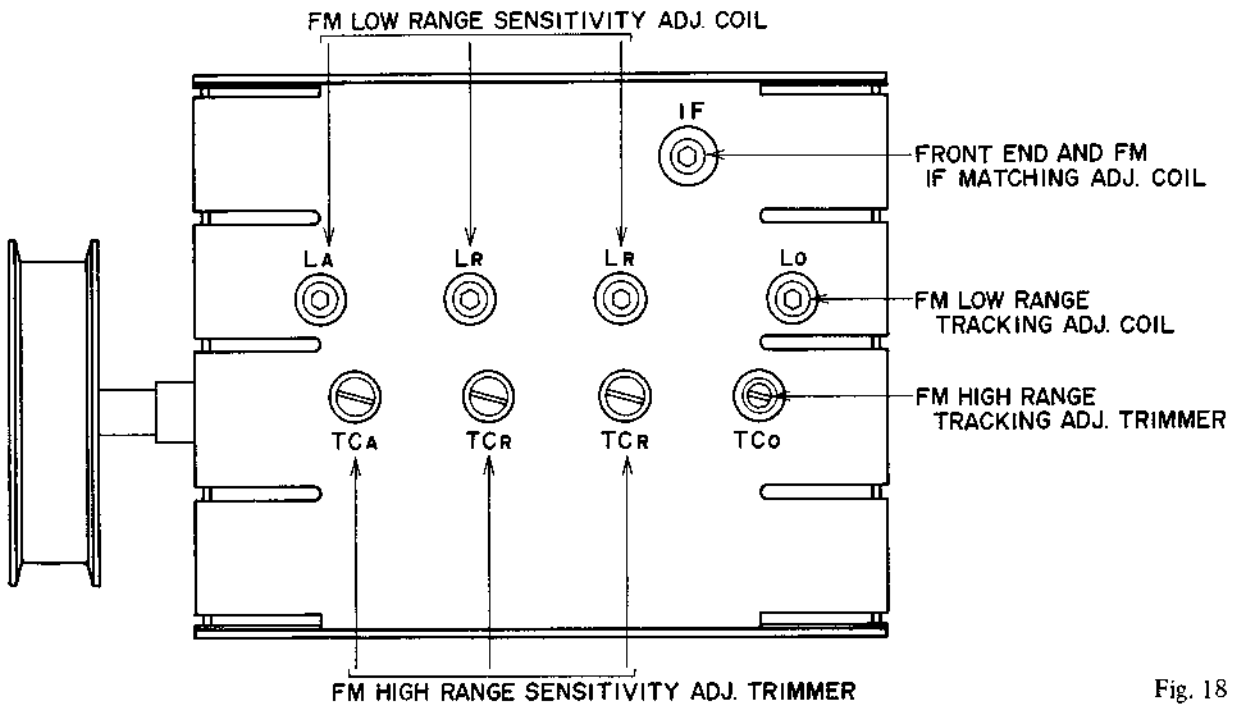

Fig. 18

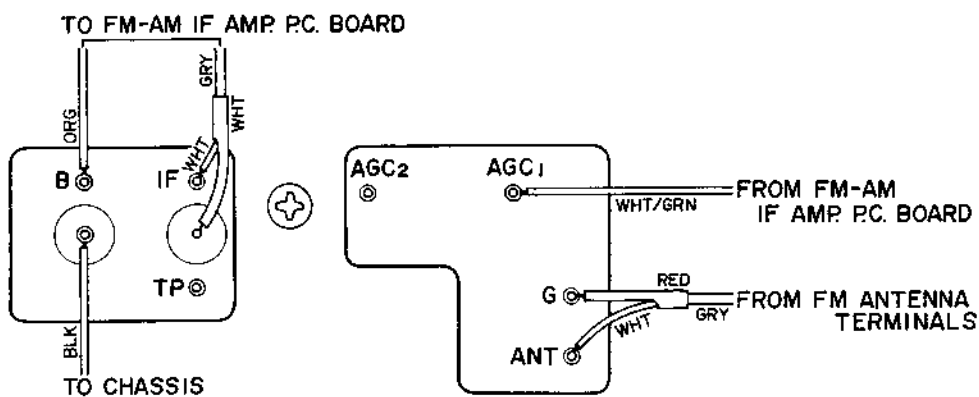

Fig. 19

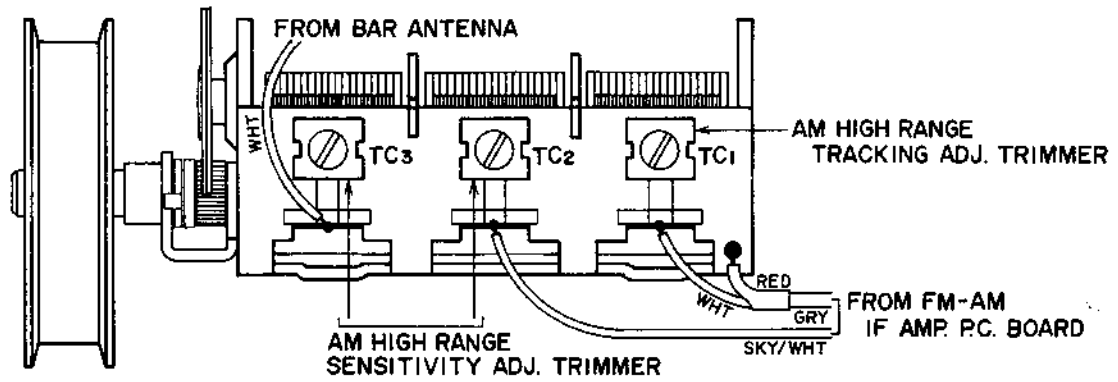

Fig. 20

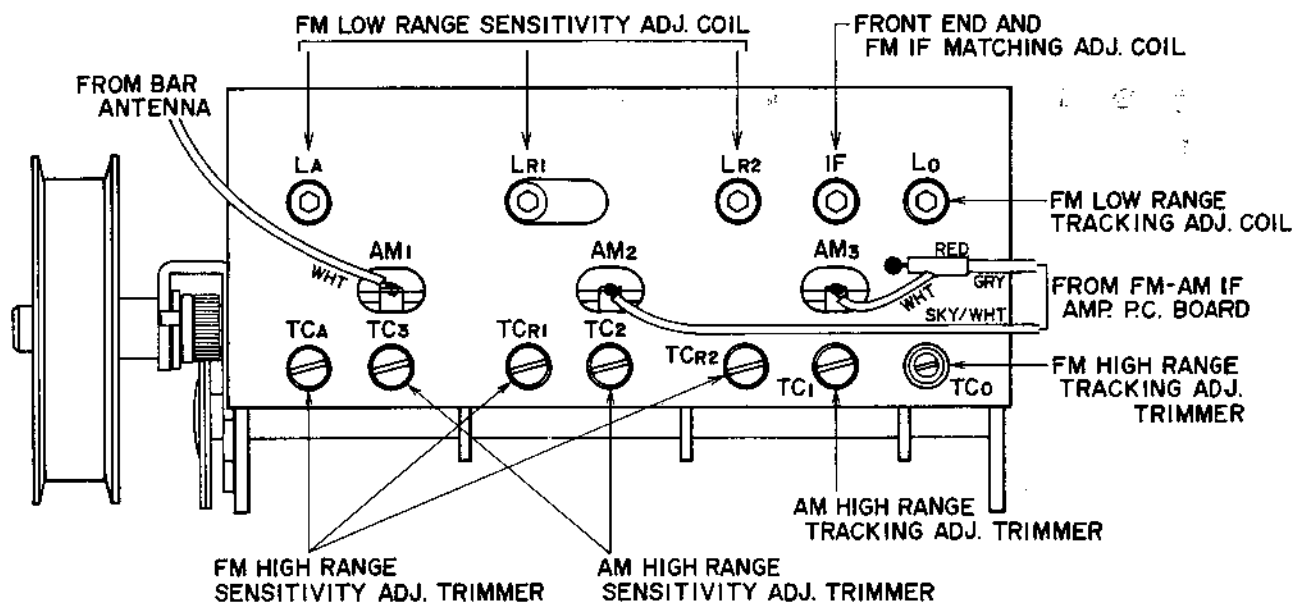

Fig. 21

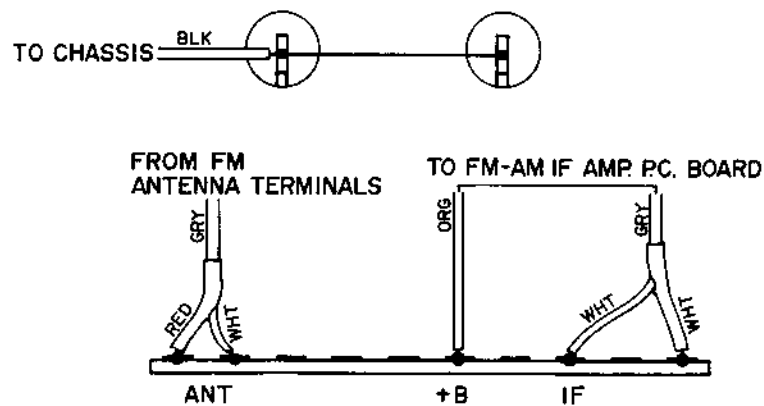

Fig. 22

VIII. POWER AMPLIFIER ADJUSTMENTS

(Models AA-940, AA-930)

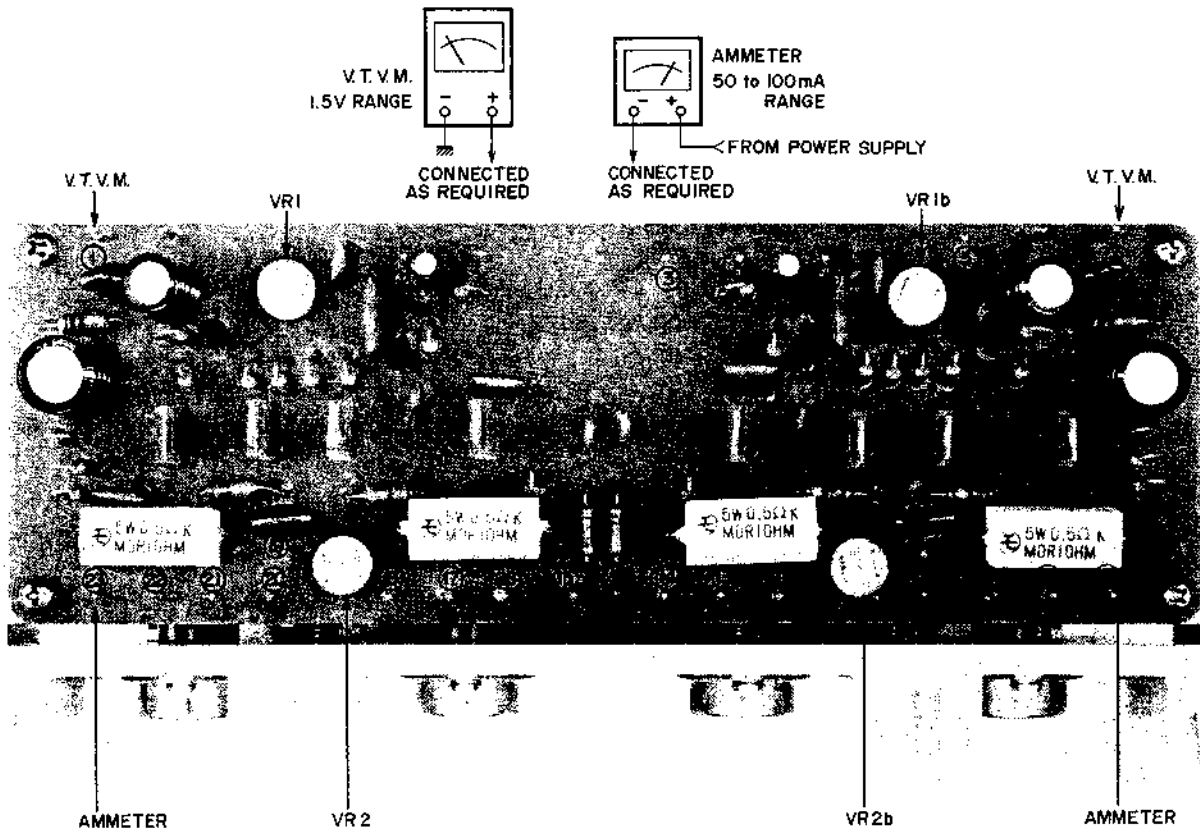

Fig. 23 POWER AMP. P.C. BOARD 94-5013

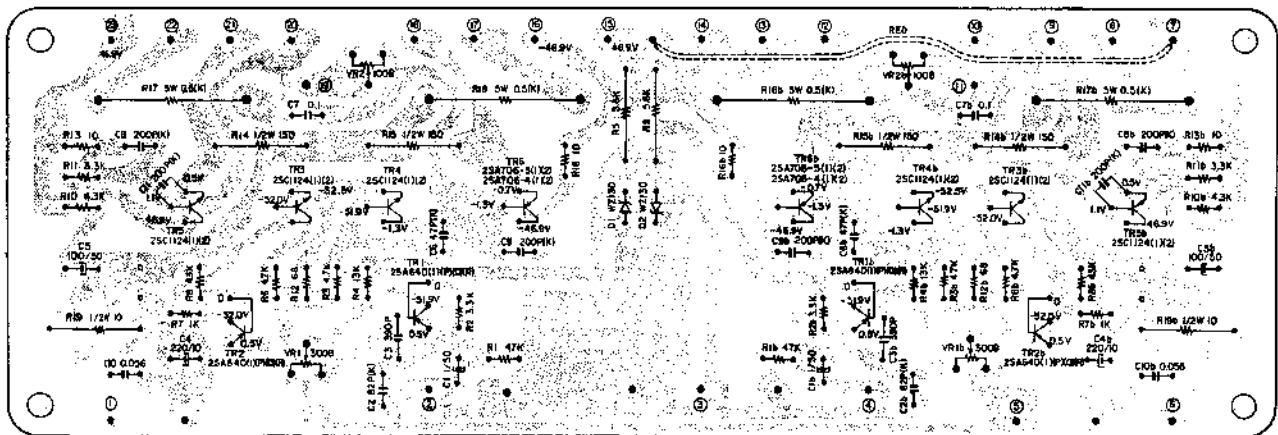

Fig. 24 POWER AMP. P.C. BOARD 94-5013 (Rev. Side)

1. POWER AMP. NON-INPUT CURRENT ADJUSTMENT (Refer to Fig. 22)

- 1) Disconnect the lead wires (Red) of terminals (7), (23) of Power Amp. P.C. Board from power supply.
- 2) Connect a 50 to 100 mA scale ampere meter between power supply and the Power Amp. P.C. Board terminals.
- 3) Adjust Power Amp. P.C. Board semi-fixed resistors VR2 100B(Left), and VR2b 100B(Right) shown in Fig. 23 to obtain a 40 mA ampere meter indication on both left and right channels.

2. ZERO ELECTRICAL POTENTIAL ADJUSTMENT (Refer to Fig. 23)

- 1) Set V.T.V.M. to 1.5V D.C. range and connect between terminals (1), (6) of Power Amp. P.C. Board and ground.
- 2) Adjust semi-fixed resistors VR1 300B(Left) and VR1b 300B(Right) shown in Fig. 23 to obtain a "0" V V.T.V.M. indication.

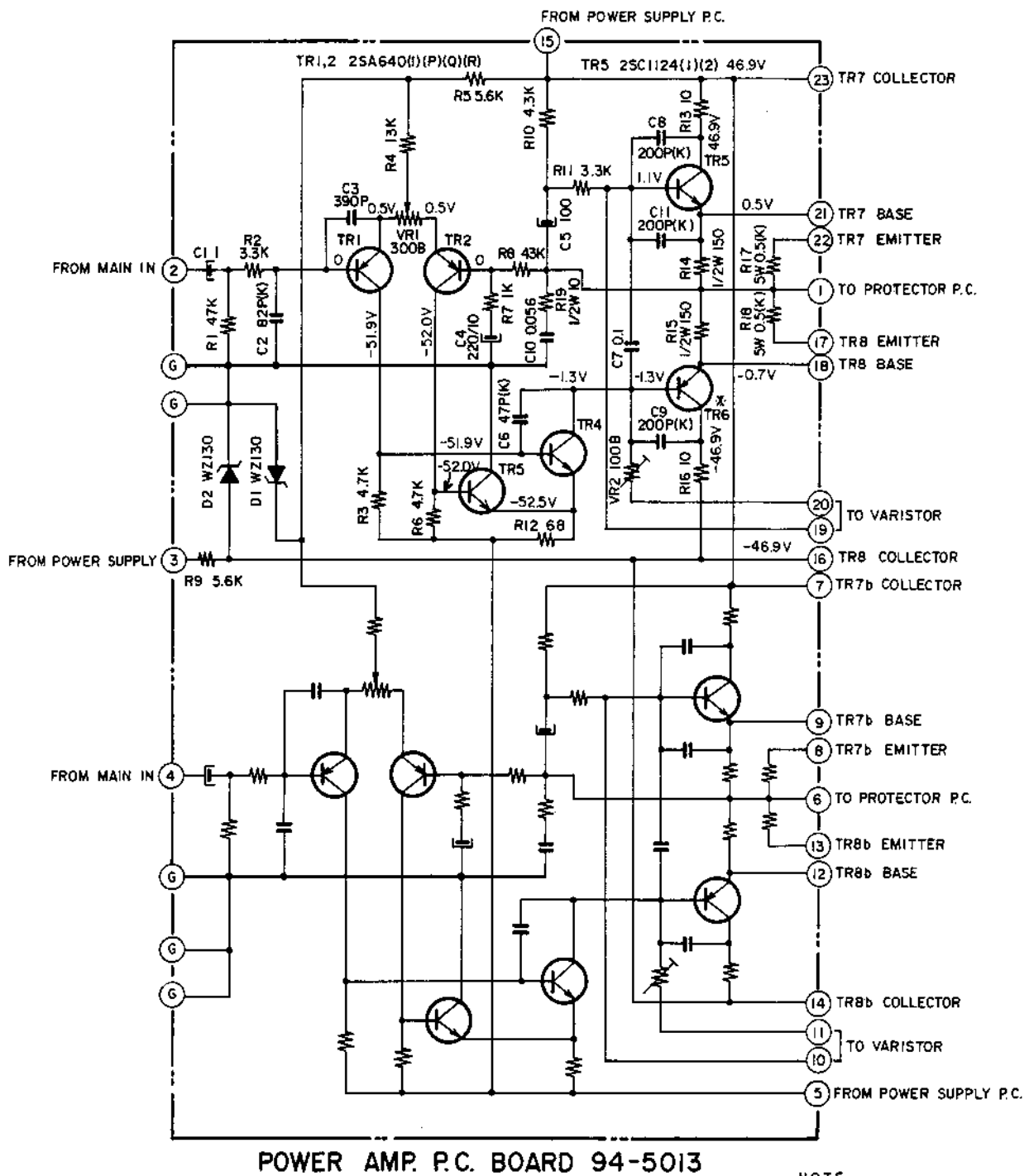

NOTE
 UNLESS OTHERWISE SPECIFIED
 ALL RESISTORS IN Ω 1/4W (J)
 ALL CAPACITORS IN μ F 50W.V.(J)
 * TR6 2SA706-5 (1)(2) AA-940
 2SA706-4 (1)(2) AA-930

SCHMATIC 3

IX. POWER AMPLIFIER ADJUSTMENTS

(Model AA-920)

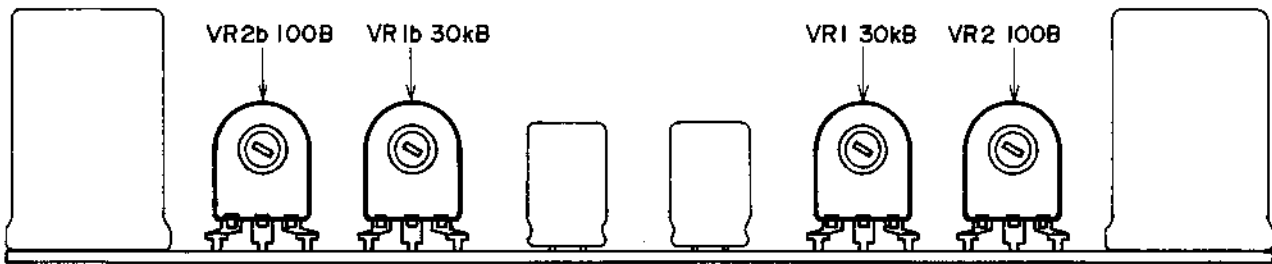

Fig. 25

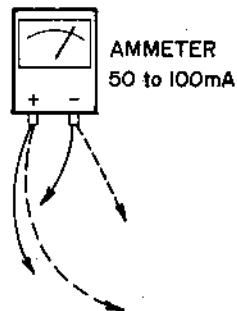

Fig. 26

1. POWER AMP. NON-INPUT CURRENT ADJUSTMENT (Refer to Figs. 26,27)

- 1) As shown in Fig. 27, remove solder from soldering point of Power Amp. P.C. Board.
- 2) Connect a 50 to 100 mA scale ampere meter to the place from which the solder was removed in Item 1-1).
- 3) Adjust semi-fixed resistors VR2 100B(Left) and VR2b 100B(Right) of Power Amp. P.C. Board shown in Fig. 26 to obtain a 40 mA ampere meter indication on both the left and right channels.

2. VOLTAGE ADJUSTMENT BETWEEN POWER TRANSISTORS C-E

- 1) Connect ampere meter to collector of P.C. Board Power Transistors TR6, TR6b shown in Fig. 27.
- 2) Adjust semi-fixed resistors VR1 30 kB(Left) and VR1b 30 kB(Right) of Power Amp. P.C. Board shown in Fig. 26 to obtain half the value of the power source voltage.

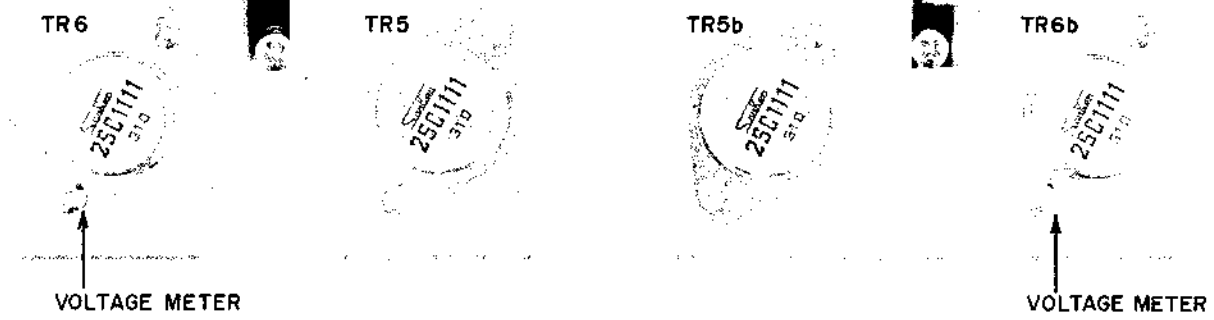
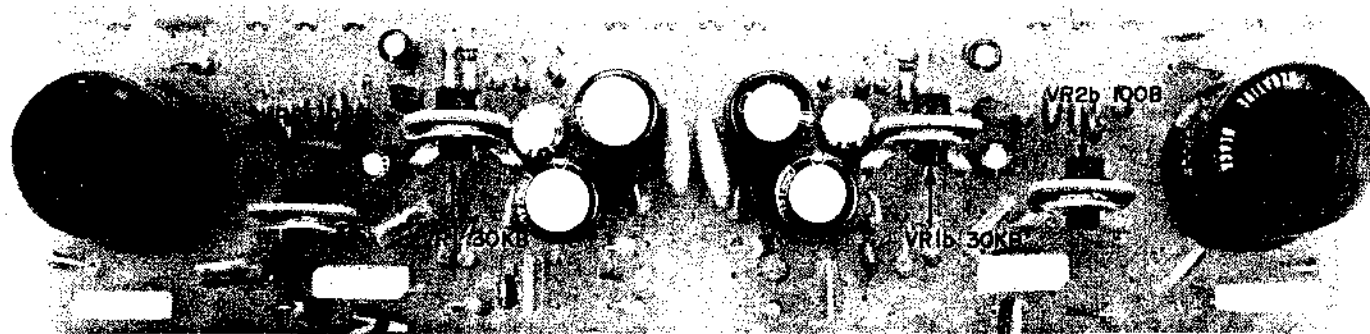

Fig. 27 POWER AMP. P.C. BOARD 92-5005

K

X. TUNING CORD THREADING

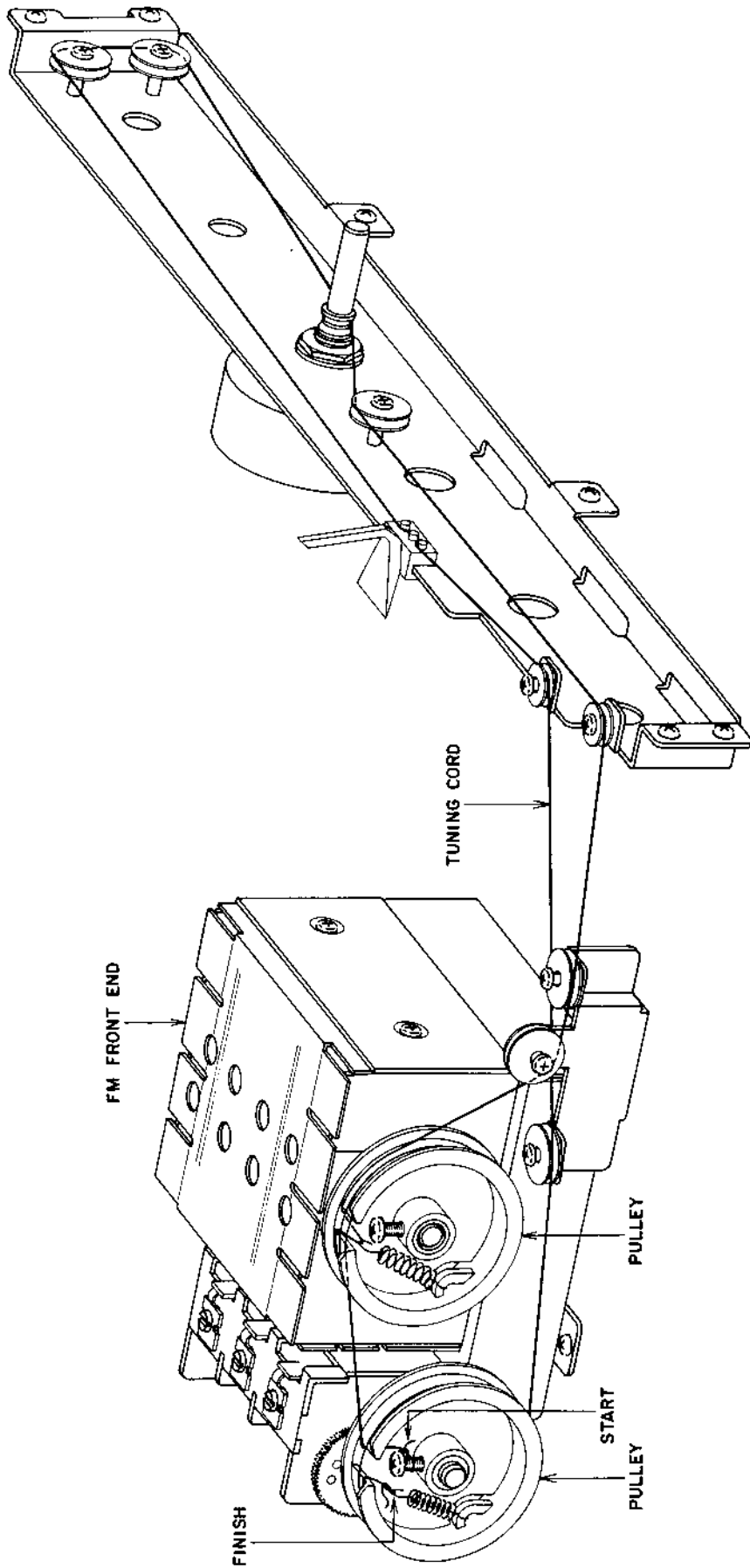

Fig. 29 Model AA-940

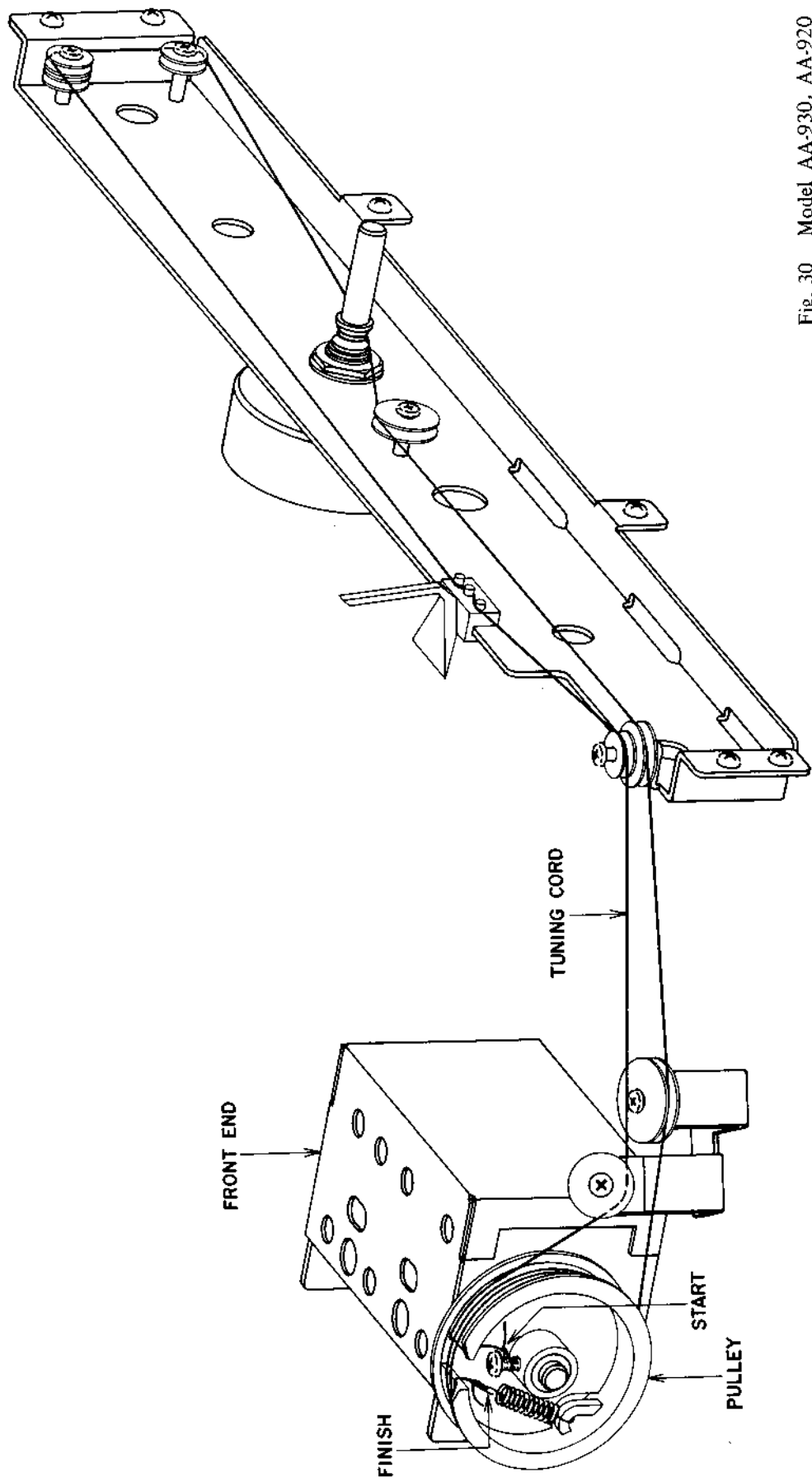
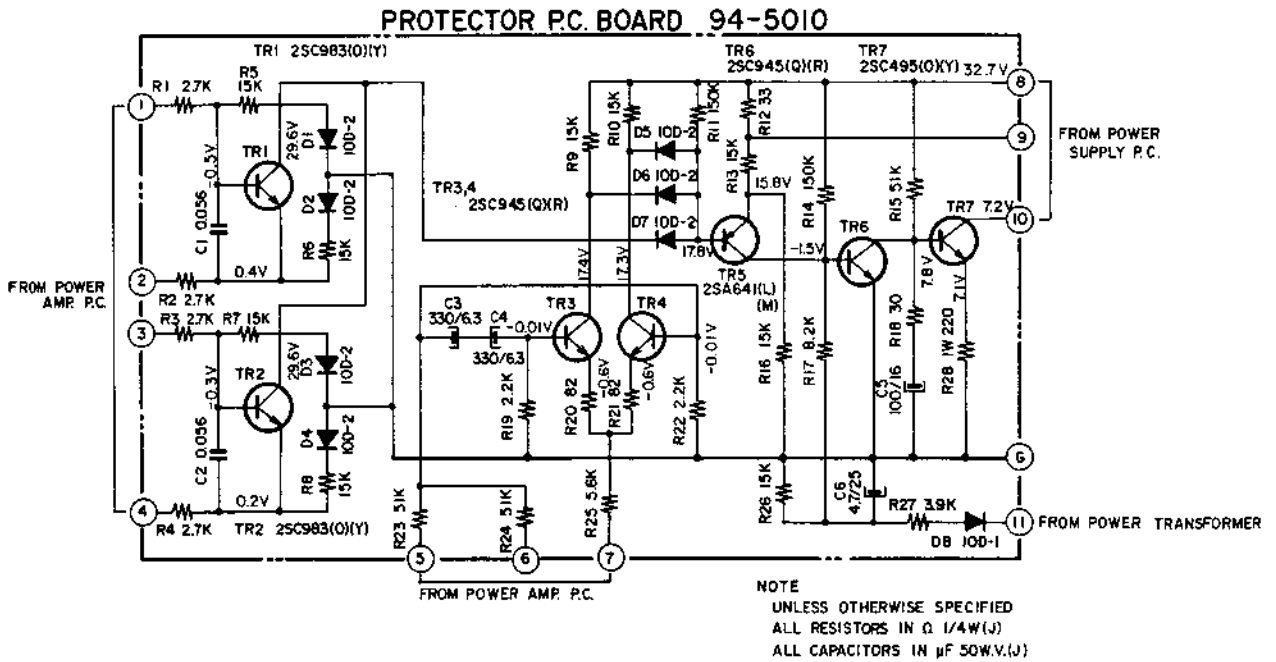
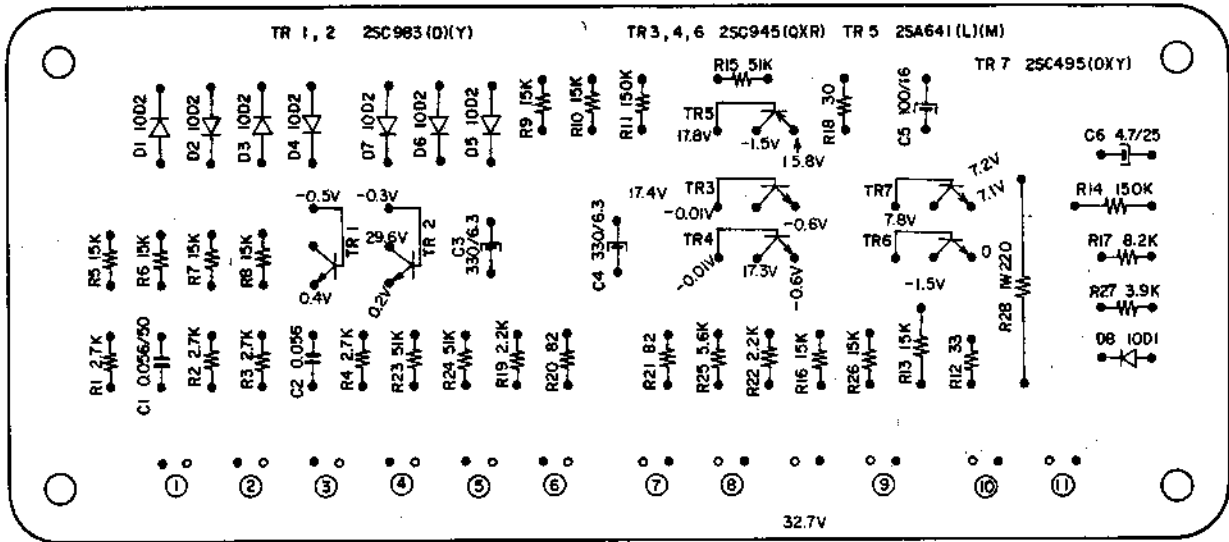

Fig. 30 Model AA-930, AA-920

XI. COMPOSITE VIEWS OF COMPONENTS

1. PROTECTOR P.C. BOARD 94-5010



SCHEMATIC 5

2. POWER SUPPLY P.C. BOARD 94-5011

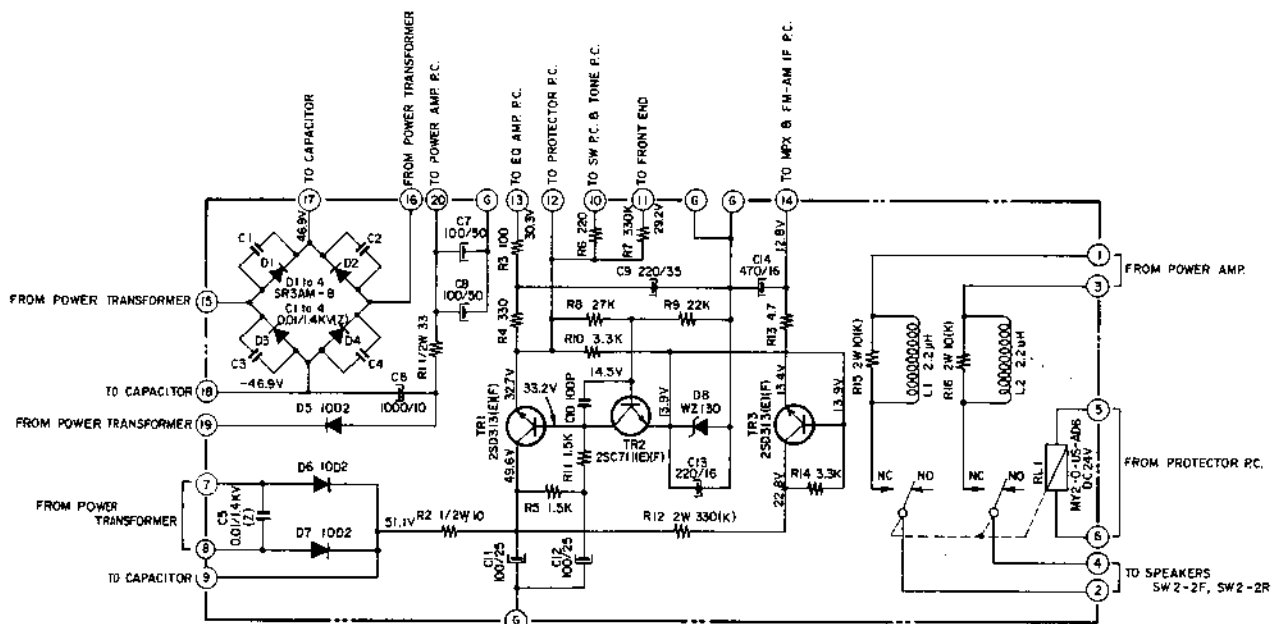
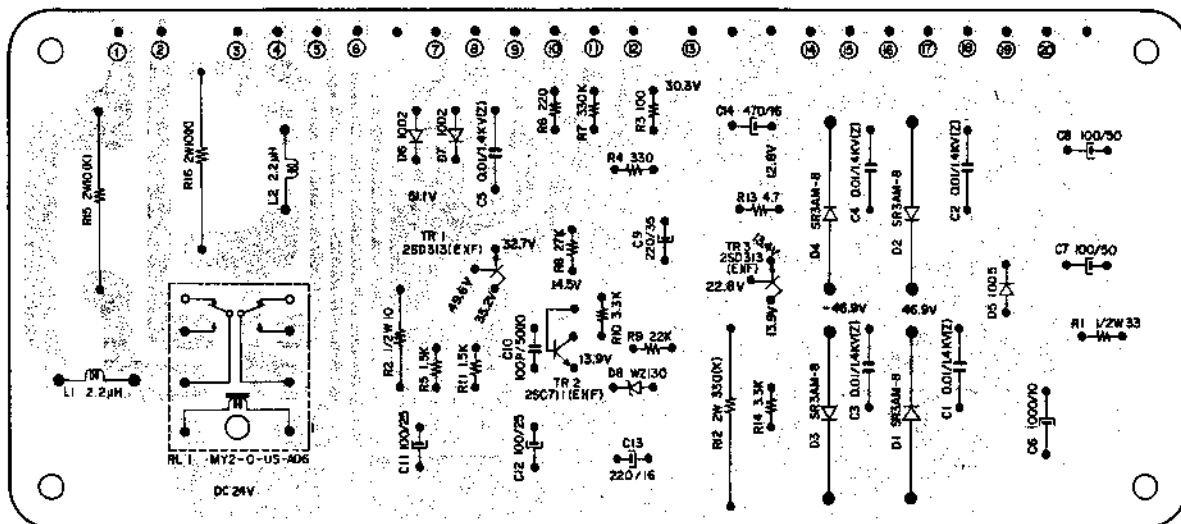

NOTE
UNLESS OTHERWISE SPECIFIED
ALL RESISTORS IN Ω 1/4W (J)
ALL CAPACITORS IN μF 50 V.D.V. (J)

SCHEMATIC 6

4. EQ. P.C. BOARD 94-5012

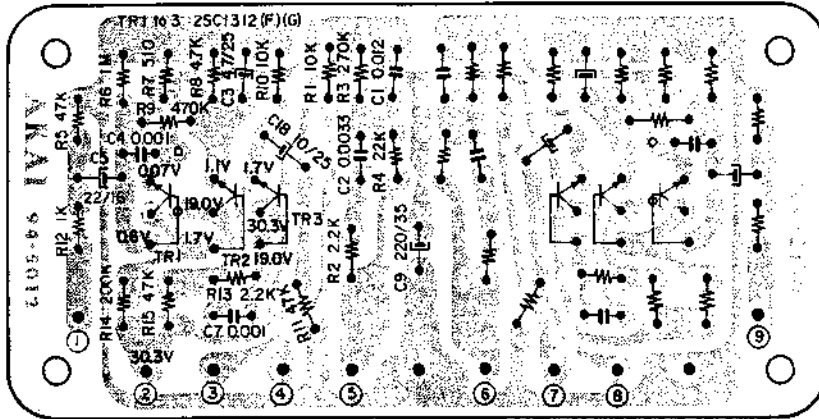

EQ AMP. P.C. BOARD 94-5012

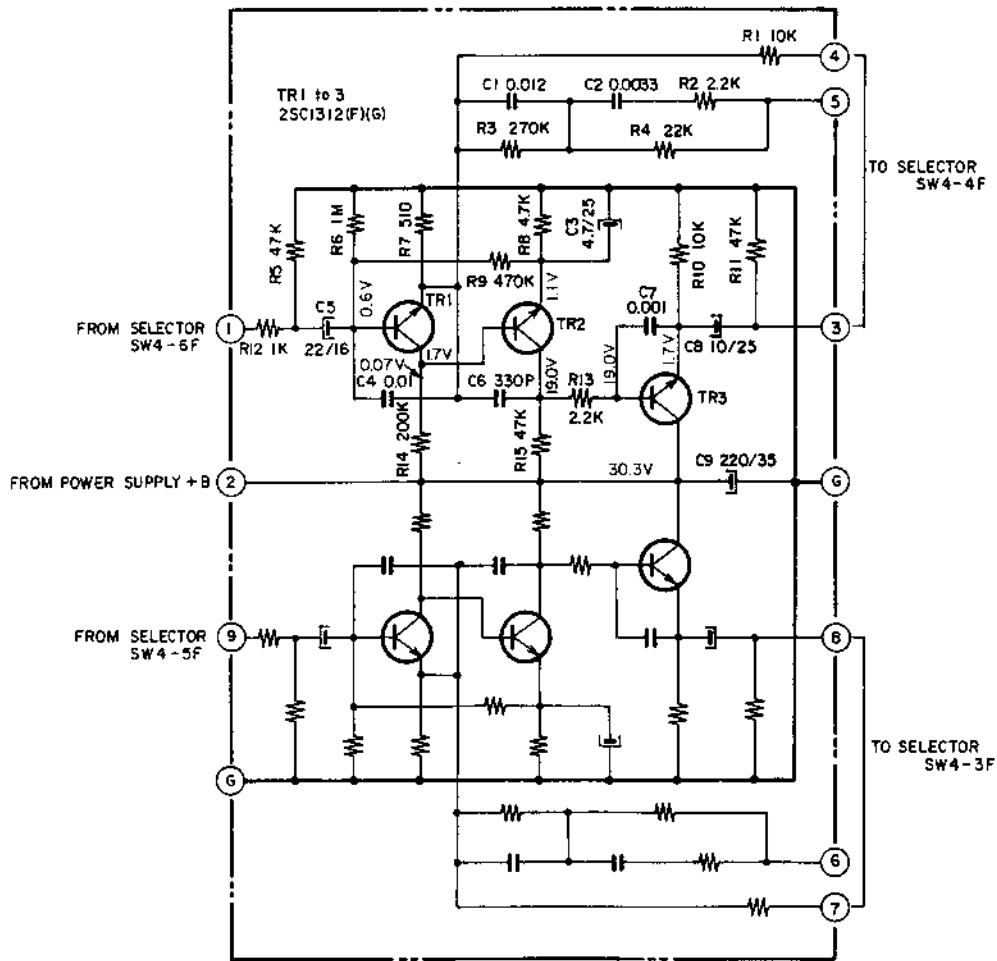

NOTE
 UNLESS OTHERWISE SPECIFIED
 ALL RESISTORS IN Ω 1/4W(J)
 ALL CAPACITORS IN μ F 50W.V.(J)

SCHAMATIC 8

5. EQ. P.C. BOARD 92-5003

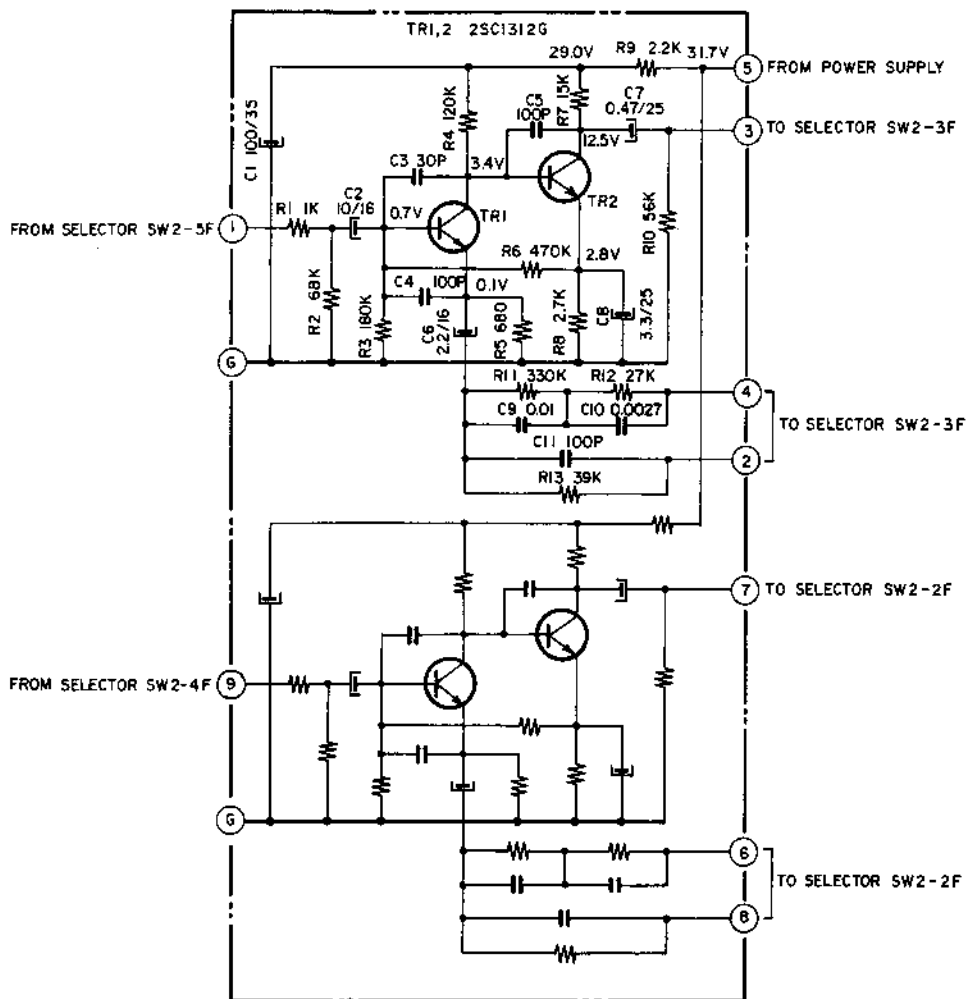
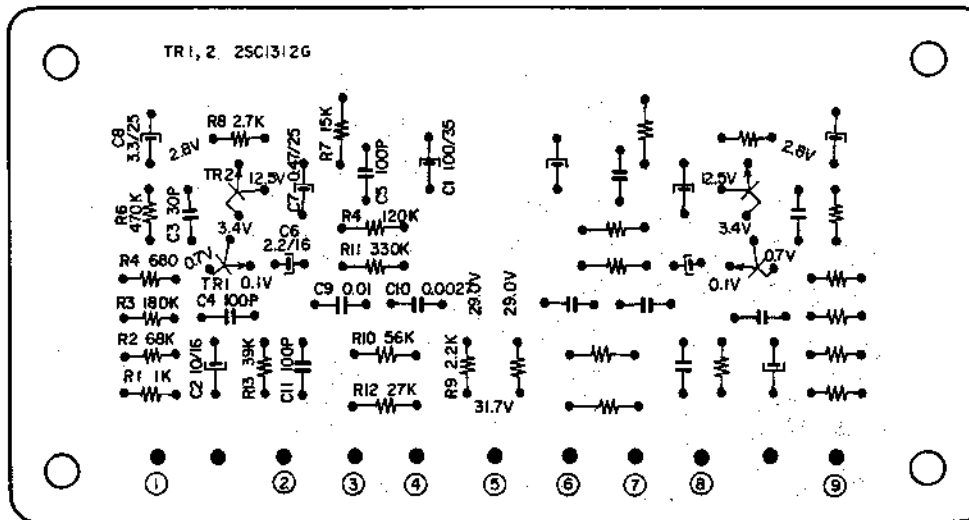

EQ AMP. P.C. BOARD 92-5003

NOTE
UNLESS OTHERWISE SPECIFIED
ALL RESISTORS IN Ω 1/4W(J)
ALL CAPACITORS IN μ F 50W.V.(J)

SCHAMATIC 9

7. TONE CONTROL P.C. BOARD 92-5010

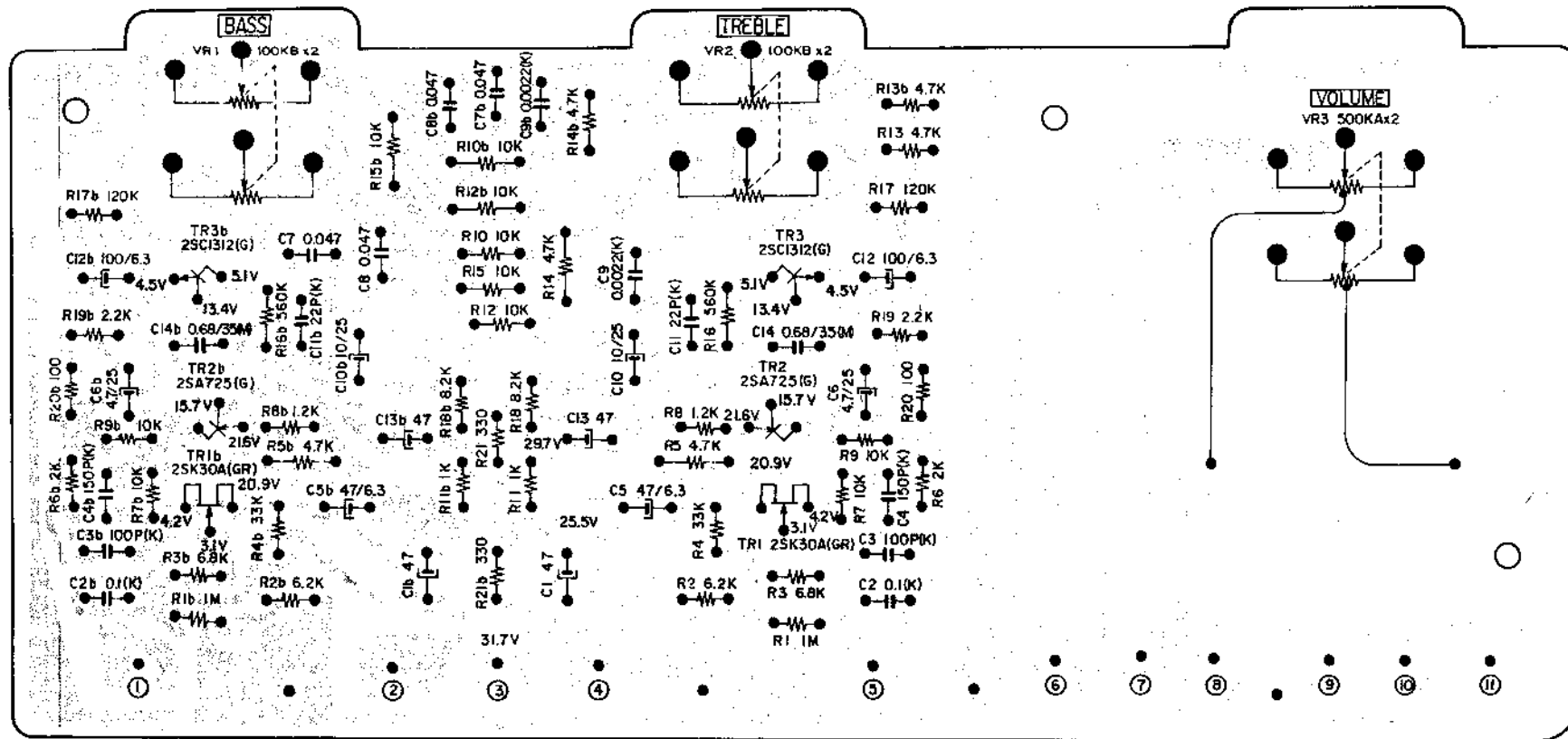

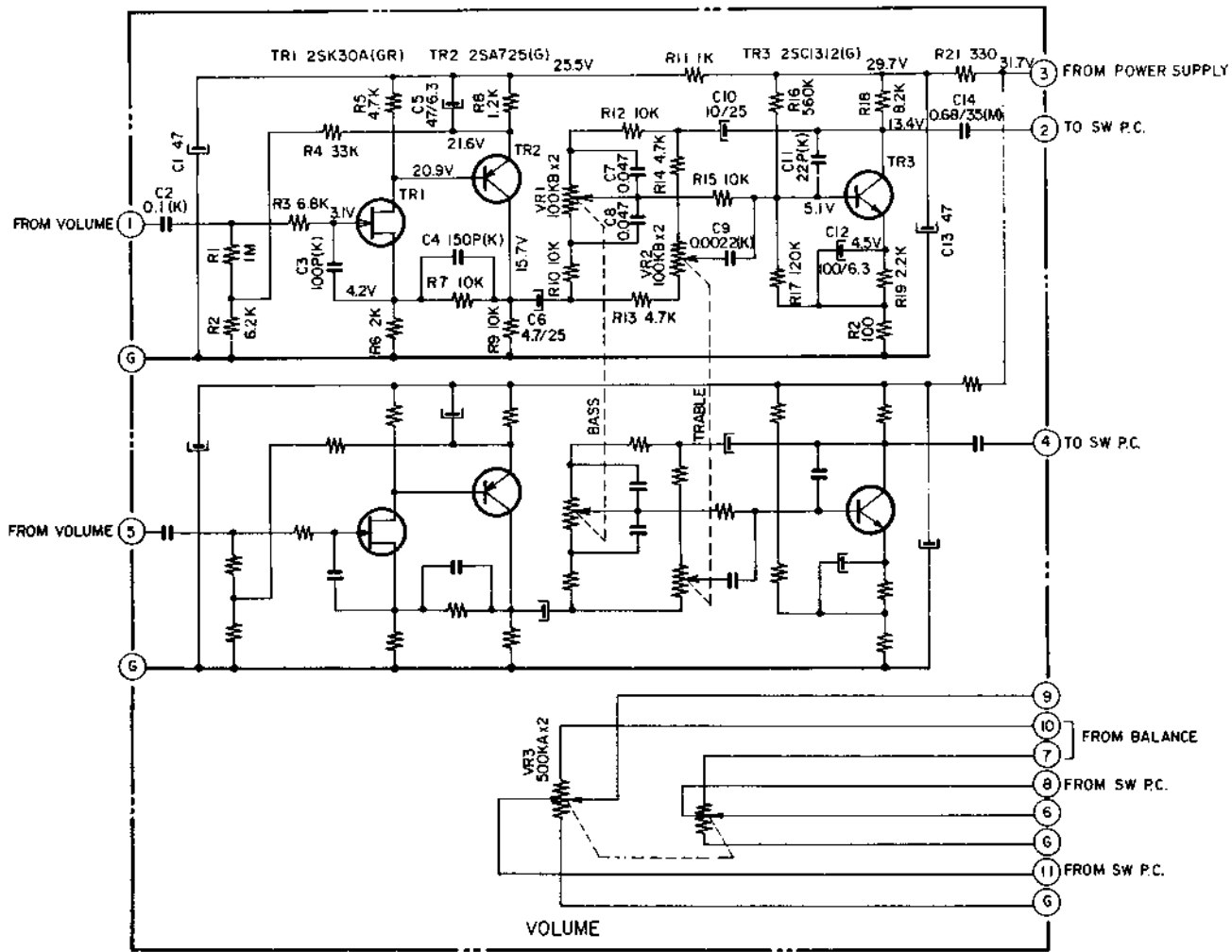

TONE CONTROL P.C. BOARD 92 - 5010

NOTE
 UNLESS OTHERWISE SPECIFIED
 ALL RESISTORS IN Ω 1/4W.(J)
 ALL CAPACITORS IN μ F 50W.V.(U)

SCHAMATIC 11

8. SWITCH P.C. BOARD 94-5020

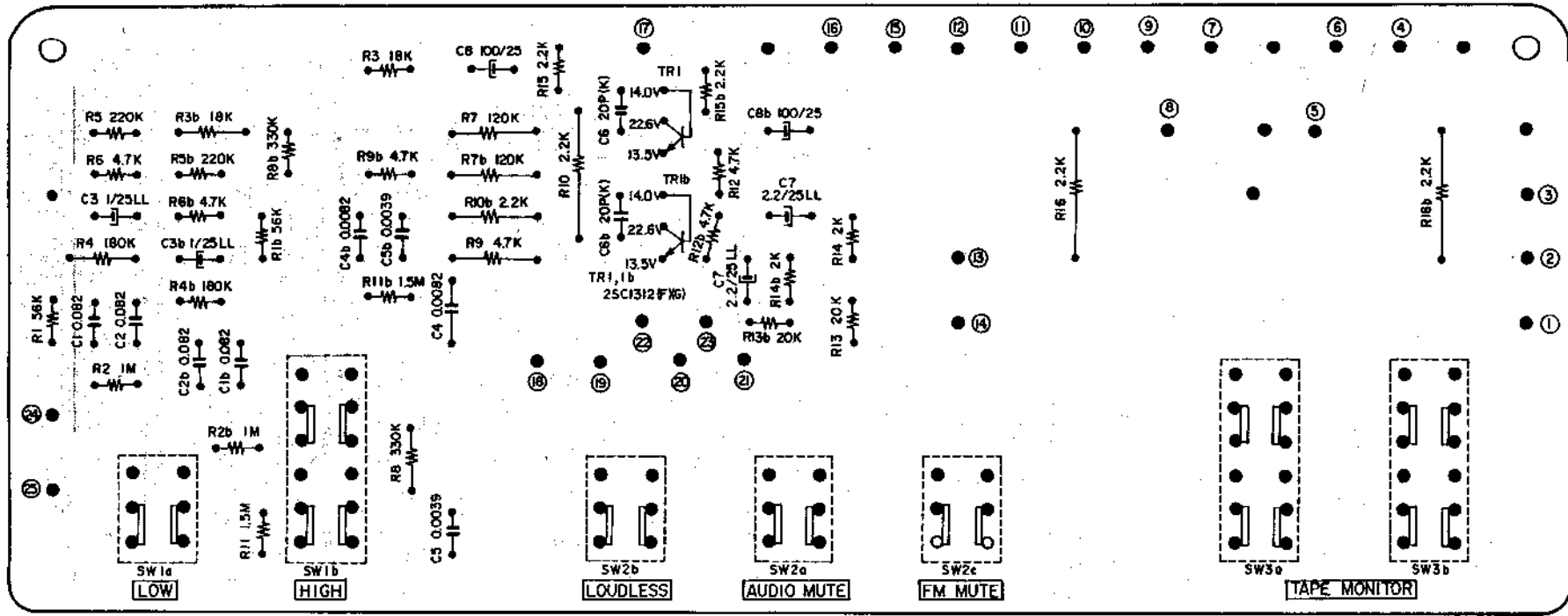

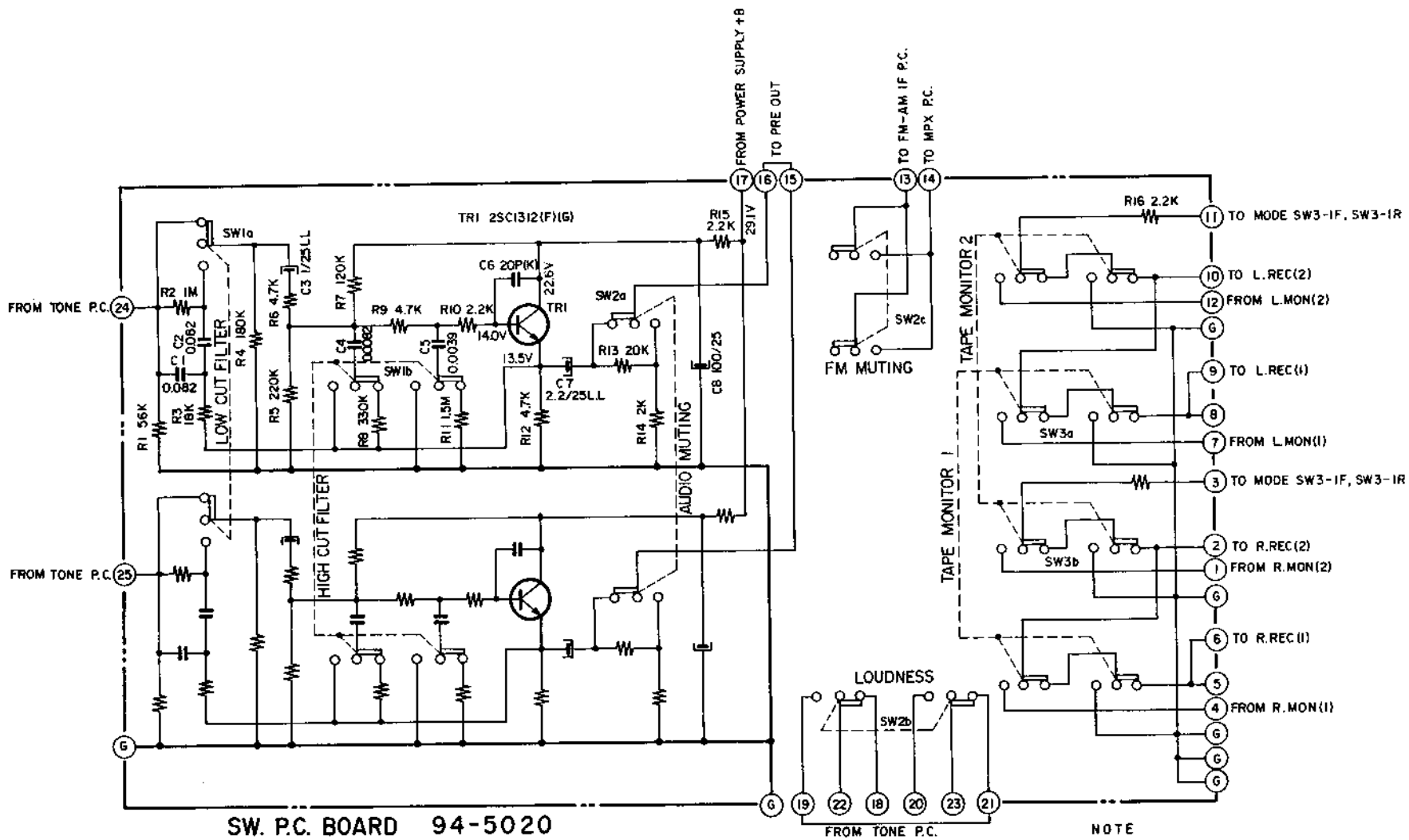

NOTE
 UNLESS OTHERWISE SPECIFIED
 ALL RESISTORS IN Ω 1/4W (J)
 ALL CAPACITORS IN μ F 50W.V.(J)
 LL INDICATES LOW LEAKAGE CAPACITORS

SCHAMATIC 12

9. SWITCH P.C. BOARD 93-5005

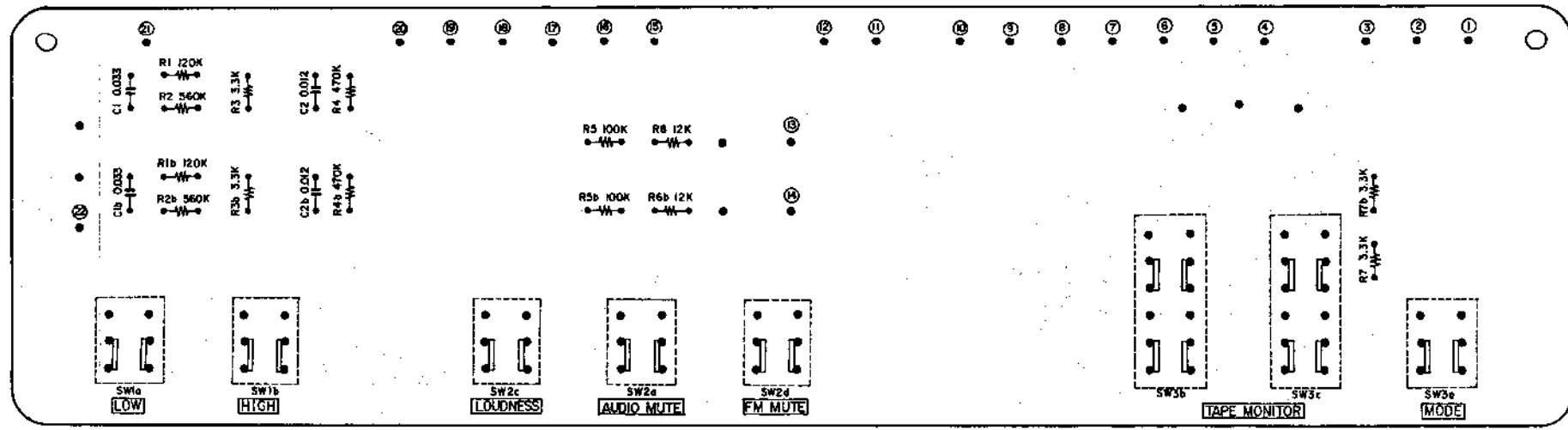

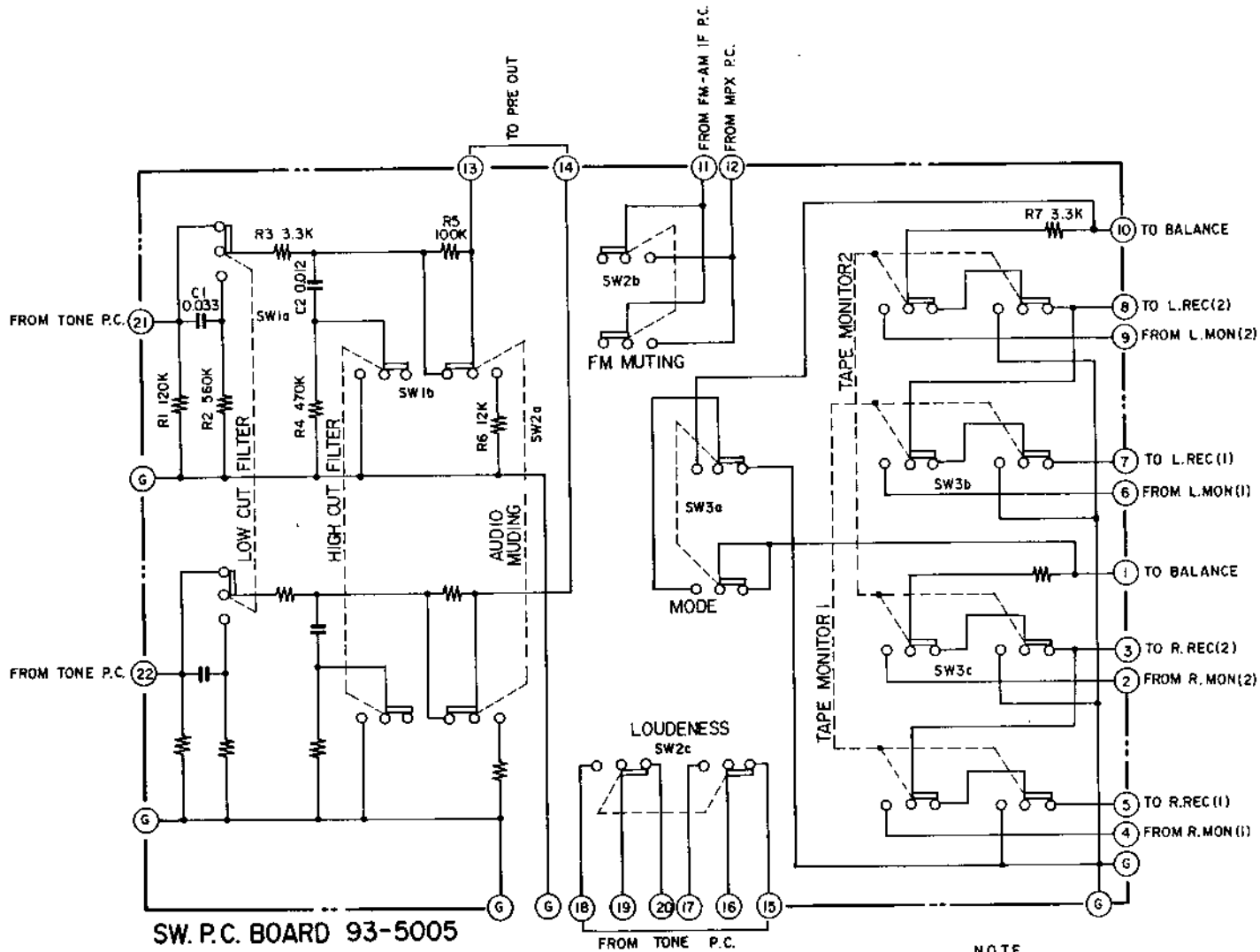

SW. P.C. BOARD 93-5005

NOTE
 UNLESS OTHERWISE SPECIFIED
 ALL RESISTORS IN Ω 1/4W(J)
 ALL CAPACITORS IN μ F 50WV(J)

SCHAMTIC 13

10. SWITCH P.C. BOARD 92-5011

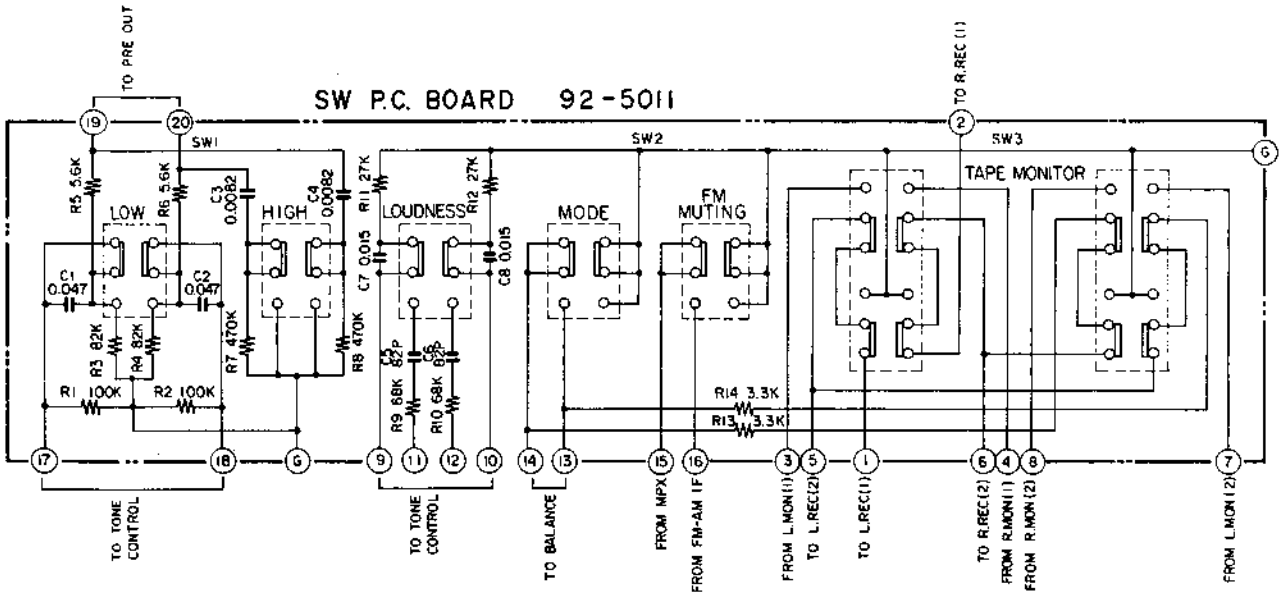
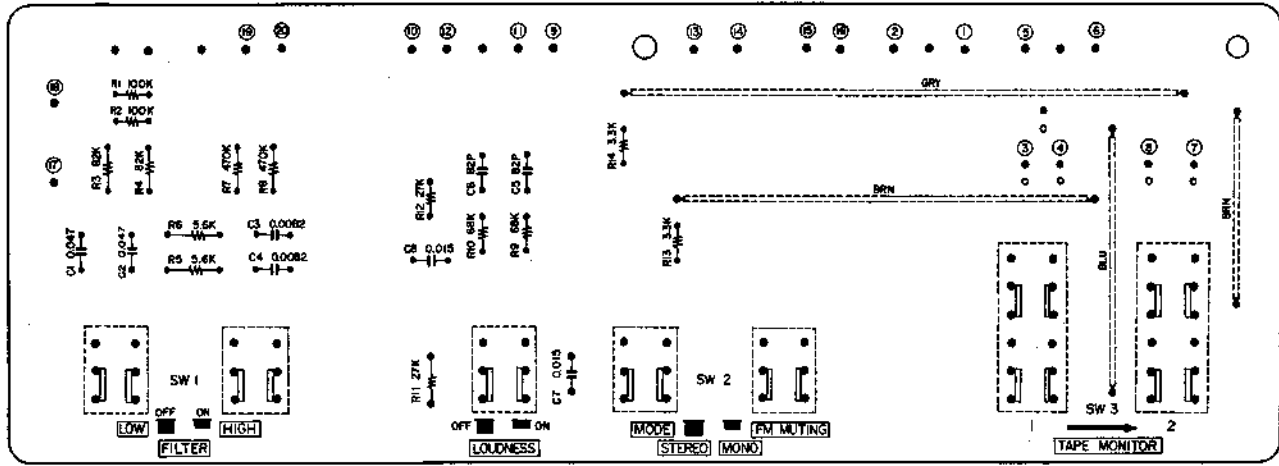

NOTE
 UNLESS OTHERWISE SPECIFIED
 ALL RESISTORS IN Ω 1/4W(J)
 ALL CAPACITORS IN μ F 50W.V.(J)

SCHAMATIC 14

2

11. DIMMER P.C. BOARD 94-5023

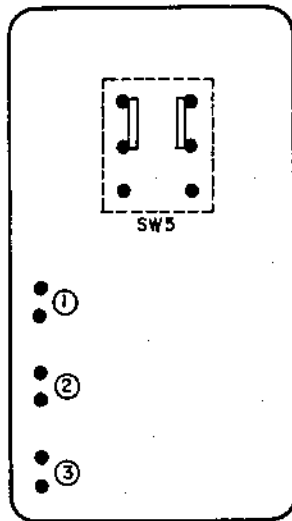

12. MIC. P.C. BOARD 94-5021

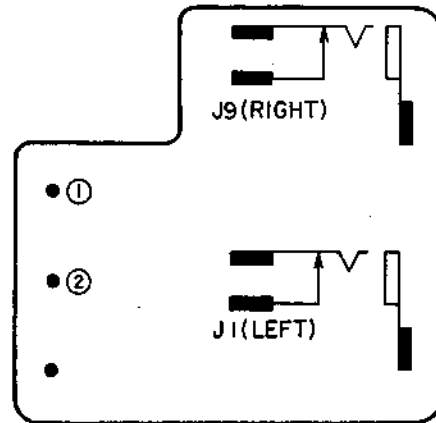

13. PHONE P.C. BOARD 94-5022

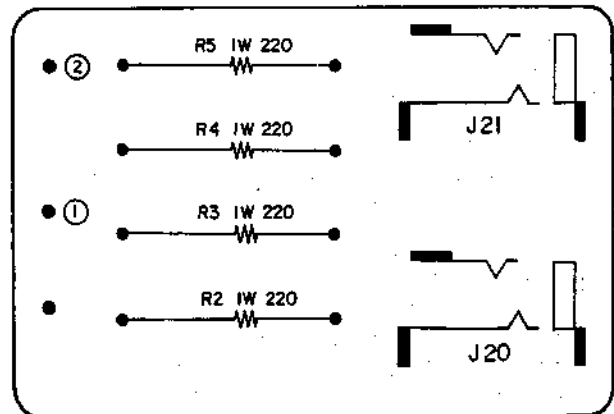

SECTION 2
PARTS LIST

TABLE OF CONTENTS

FIG. 1	MPX P.C. BOARD (94-5008) BLOCK	52
FIG. 2	IF P.C. BOARD (94-5009) BLOCK	53
FIG. 3	MIC. P.C. BOARD (94-5021) BLOCK	55
FIG. 4	PHONE P.C. BOARD (94-5022) BLOCK	55
FIG. 5	PROTECTOR P.C. BOARD (94-5010) BLOCK	56
FIG. 6	POWER SUPPLY P.C. BOARD (94-5011) BLOCK	57
FIG. 7	POWER SUPPLY P.C. BOARD (92-5004) BLOCK (AA-920)	58
FIG. 8	EQ. P.C. BOARD (94-5012) BLOCK	59
FIG. 9	EQ. P.C. BOARD (92-5003) BLOCK (AA-920)	59
FIG. 10	MAIN AMP. (94-5013) BLOCK	60
FIG. 11	MAIN AMP. P.C. BOARD (92-5005) BLOCK (AA-920)	62
FIG. 12	TONE CONTROL P.C. BOARD (94-5025) BLOCK	64
FIG. 13	TONE CONTROL P.C. BOARD (92-5010) BLOCK (AA-920)	65
FIG. 14	DIMMER P.C. BOARD (94-5023) BLOCK	66
FIG. 15	SWITCH P.C. BOARD (94-5020) BLOCK	66
FIG. 16	SWITCH P.C. BOARD (93-5005) BLOCK (AA-930)	67
FIG. 17	SWITCH P.C. BOARD (92-5011) BLOCK (AA-920)	67
FIG. 18	DIAL ILLUMINATION P.C. BOARD (AA-5029) BLOCK	68
FIG. 19	DIAL ILLUMINATION P.C. BOARD (91-5035) BLOCK (AA-920)	69
FIG. 20	FRONT CHASSIS BLOCK	70
FIG. 21	SCALE PLATE/REAR PANEL BLOCK	72
FIG. 22	ASSEMBLY BLOCK	74
FIG. 23	FINAL ASSEMBLY BLOCK	76
INDEX		77

HOW TO USE THIS PARTS LIST

1. This parts list is compiled by various individual blocks based on assembly process.
2. When ordering parts, please describe parts number, serial number, and model number in detail.
3. How to read list.

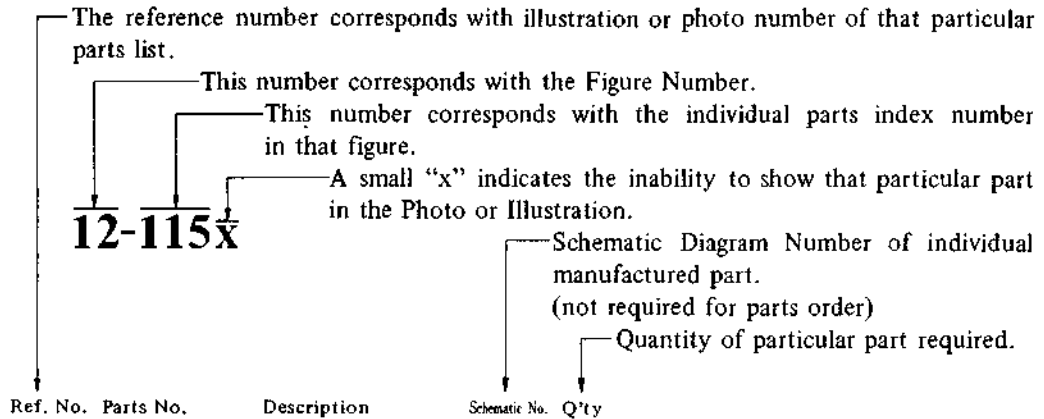

Ref. No.	Parts No.	Description	Schematic No.	Q'ty
FLYWHEEL BLOCK #13				
12-115x	800425	Flywheel Block Assy. Comp.	RDG#13	1
12-116	244506	Flywheel Only	RD-233	1
12-117x	244754	Felt, Flywheel	RD-275	1
12-118	251324	Main Metal Case	RD-236	1
12-119	253080	Main Metal	RD-237	1

4. The symbol numbers shown on the P.C. Board list can be matched with the Composite Views of components of the Schematic Diagram or Service Manual.
5. The indications of Resistors and Capacitors in the photos of P.C. Board are being eliminated.
6. The shape of the parts and parts name, etc. can be confirmed by comparing them with the parts shown on the Electrical Parts Table of P.C. Board.
7. Both the kind of part and installation position can be determined by the Parts Number. To determine where a parts number is listed, utilize Parts Index at end of Parts List.
It is necessary first of all to find the Parts Number. This can be accomplished by using the Reference Number listed at right of parts number in the Parts Index. (meaning of ref. no. outlined in Item 3 above).
8. Utilize separate "Price List for Parts" to determine unit price. The most simple method of finding parts Price is to utilize the reference number.

NOTE: In the parts list US-A is the chief standard. Parts used in other than US-A standard areas are itemized by region. Parts not itemized by region can be used in all areas.

Standard	Packing Carton Sticker	AC Cord	Region	
US	US-A	AAL 120V	AC Cord CUL	AAL
		EP 110V	AC Cord CUL	PX
	US-B	PRESET 220V	AC Cord CUL	Holland
		PRESET 110V	AC Cord CUL	110V Area
		PRESET 240V 3 CORE	3 Core without Plug	3 Core Area
	WG 220V	HEW-P79	WG	
	CSA	CSA 120V	AC Cord CUL	CSA
CEE	CEE 220V	HEW-P65	CEE	
J	J 100V	AC Cord Domestic	Domestic	
A	SA 240V 3 CORE	3 Core without Plug	South Africa	

ELECTRICAL PARTS TABLE



<p>Because the indication of resistors and capacitors in the P. C. Board photos are being eliminated, please confirm parts name and shape by comparing them with the parts shown in this table.</p>	<p>1</p>  <p style="text-align: center;">Solid Resistor</p>	<p>2</p> <p style="text-align: right;">Stopper Type</p>  <p style="text-align: center;">Insulator Type</p> <p style="text-align: center;">Carbon Resistor</p>	<p>3</p>  <p style="text-align: center;">Metal Oxide Film Resistor</p>
<p>4</p>  <p style="text-align: center;">Cement Resistor</p>	<p>5</p>  <p style="text-align: center;">Wire-Wound Resistor</p>	<p>6</p>  <p style="text-align: center;">Thermister</p>	<p>7</p>  <p style="text-align: center;">Enamel Resistor</p>
<p>1</p>  <p style="text-align: center;">MP Capacitor (Tubular Type)</p>	<p>2</p>  <p style="text-align: center;">Plastic Capacitor</p>	<p>3</p>  <p style="text-align: center;">Mylar Capacitor</p>	<p>4</p>  <p style="text-align: center;">VEM (Hi-Q) Capacitor</p>
<p>5</p>  <p style="text-align: center;">Mylar Capacitor</p>	<p>6</p>  <p style="text-align: center;">Tantalum Capacitor</p>	<p>7</p>  <p style="text-align: center;">Oil Capacitor (Tubular Type)</p>	<p>8</p> <p style="text-align: right;">Vertical Type</p> <p>(Tubular Type)</p>  <p style="text-align: center;">StyroI Capacitor</p>
<p>9</p>  <p style="text-align: center;">Electrolytic Capacitor (Tubular Type)</p>	<p>10</p> <p style="text-align: right;">Vertical Type</p> <p>(Tubular Type)</p>  <p style="text-align: center;">Electrolytic Capacitor</p>	<p>11</p>  <p style="text-align: center;">Ceramic Capacitor</p>	<p>12</p>  <p style="text-align: center;">Metalized Mylar (Paper) Capacitor</p>
<p>13</p>  <p style="text-align: center;">Trimmer Condenser</p>		<p>VR</p>  <p style="text-align: center;">Semi-Fixed Volume</p>	
<p>L</p>  <p style="text-align: center;">Ferri Inductor</p>	<p>TR</p>  <p style="text-align: center;">Transistor</p>		
<p>CR</p>  <p style="text-align: center;">Spark Quencher</p>	<p>D</p>  <p style="text-align: center;">Diode (Silicon, Zener, Germanium)</p>		

FIG. 1 PHOTO OF MPX P.C. BOARD (94-5008)



MPX P.C. BOARD (94-5008) BLOCK

Symbol No.	Parts No.	Description	Q'ty	Symbol No.	Parts No.	Description	Q'ty
1-1x	BA554477	MPX P.C. Board Comp. (94-5008)	1			Resistor, Stopper Type	
1-2x	BA556604	MPX P.C. Board Comp. (94-5008)	1	1-R1	ER346994	Carbon RD1/4 18k(J)	1
		(920)	1	1-R2	ER357491	Carbon RD1/4 82k(J)	1
1-IC1	EI443744	I.C. LA-3300	1	1-R3	ER496214	Carbon RD1/4 360k(J)	1
1-TR1	ET552870	FET Transistor 2SK30(Y)(GR)	1	1-R4	ER419040	Carbon RD1/4 1M(J)	1
1-TR2, 3	ET453486	Transistor 2SC711(E) (F)	2	1-R5	ER357491	Carbon RD1/4 82k(J)	1
1-TR4, 5	ET539987	Transistor 2SC1312(F) (G)	2	1-R6	ER496214	Carbon RD1/4 360k(J)	1
1-D1, 2	ED219464	Germanium Diode 1N34A	2	1-R7	ER336442	Carbon RD1/4 10k(J)	1
1-L1	EO443766	Coil (19KC) 02-1070-03	1	1-R8	ER211465	Carbon RD1/4 1k(J)	1
		1070(black)	1	1-R9,10	ER343078	Carbon RD1/4 2.7k(J)	2
1-L2	EO443777	Coil (38KC) 02-1064-03	1	1-R11	ER357456	Carbon RD1/4 2.2k(J)	1
		1064(white)	1	1-R12,13	ER346601	Carbon RD1/4 47k(J)	2
1-FL1, 2	ER512201	Filter FB-24	2	1-R14,15	ER211465	Carbon RD1/4 1k(J)	2
1-SW1	ES513922	Slide SW. SSB02242	1	1-R16to19	ER380711	Carbon RD1/4 220k(J)	4
1-3	EJ539662	Lapping Post 1x17	15	1-R20,21	ER212883	Carbon RD1/4 4.7k(J)	2
		Capacitor, Vertical Type		1-R22,23	ER371946	Carbon RD1/4 2k(J)	2
1-C1	EC331828	Elect. 3.3μF 25WV	1	1-R24	ER212681	Carbon RD1/4 330(J)	1
1-C2	EC250841	Mylar 0.01μF(J) 50WV	1	1-R25,26	ER212883	Carbon RD1/4 4.7k(J)	2
1-C3	EC313244	Elect. 1μF 16WV	1	1-R27,28	ER346601	Carbon RD1/4 47k(J)	2
1-C4	EC331828	Elect. 3.3μF 25WV	1	1-R27,28	ER211858	Carbon RD1/4 12k(J) (920)	2
1-C5	EC339096	Elect. 470μF 16WV	1	1-R29,30	ER212264	Carbon RD1/4 22k(J)	2
1-C6	EC389474	Mylar 0.0015μF(J) 50WV	1	1-R29,30	ER211465	Carbon RD1/4 1k(J) (920)	2
1-C7	EC350706	Elect. 4.7μF 16WV	1				
1-C8, 9	EC220432	Elect. 2.2μF 25WV	2				
1-C10,11	EC337500	Mylar 0.0047μF(J) 50WV	2				
1-C12,13	EC250975	Mylar 0.015μF(J) 50WV	2				
1-C14,15	EC220432	Elect. 2.2μF 25WV	2				
1-C16,17	EC551463	Ceramic DD600 YW 0.001μF(Z)	2				
		50WV	2				
1-C18,19	EC350706	Elect. 4.7μF 16WV	2				
1-C20,21	EC380621	Mylar 0.0068μF(J) 50WV	2				

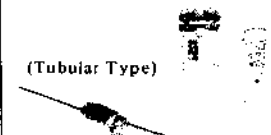
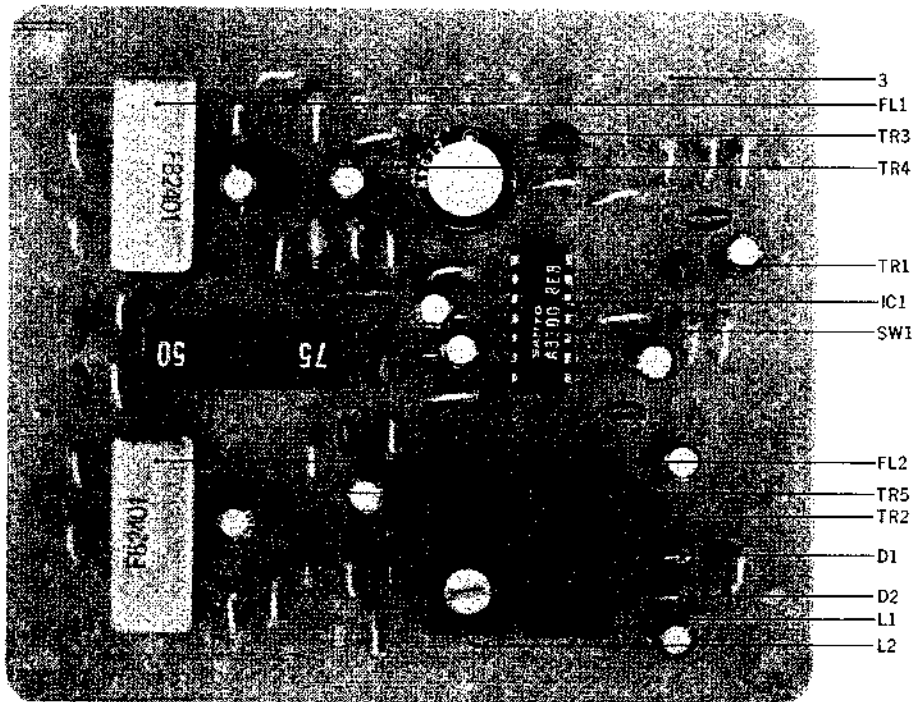
When ordering parts, please describe Parts Number, Serial Number, and Model Number in detail.

FIG. 2 PHOTO OF IF P.C. BOARD (94-5009)

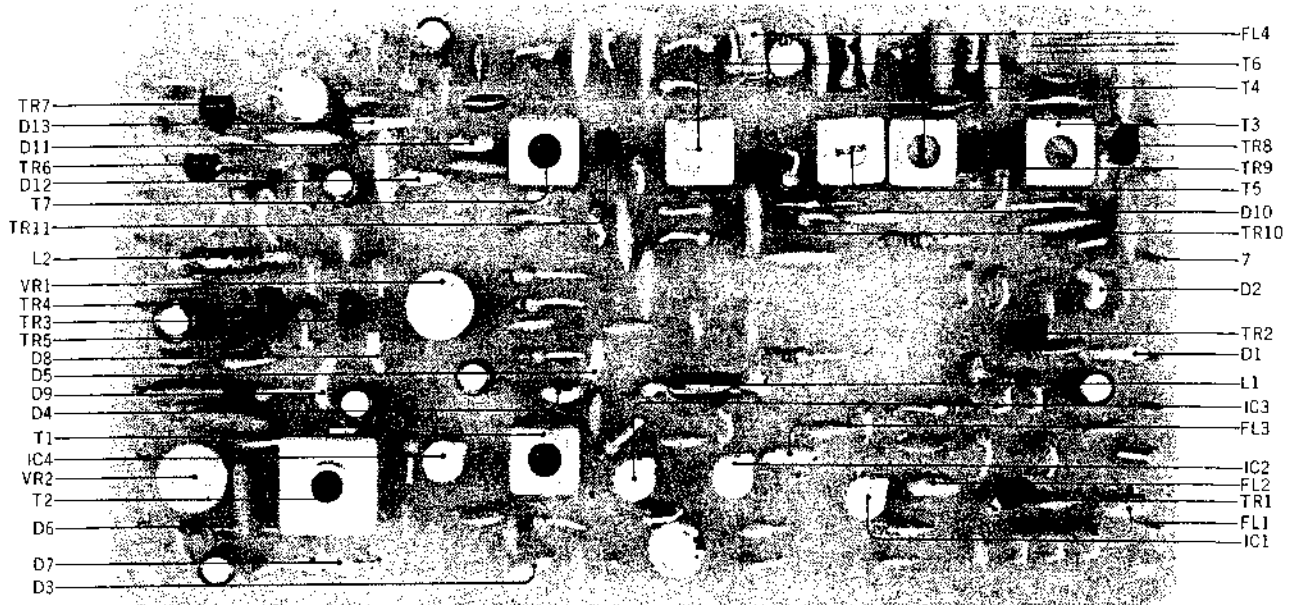

IF P.C. BOARD (94-5009) BLOCK

Symbol No.	Parts No.	Description	Q'ty	Symbol No.	Parts No.	Description	Q'ty
2-1x	BA557458	IF P.C. Board Comp. (94-5009)	1	2-C8	EC443654	VFM 15PF(K) 50WV	1
2-2x	BA563848	IF P.C. Board Comp. (94-5009)	1	2-C9 to 17	EC551441	Ceramic DD600 YM 0.01μF(Z) 50WV	9
2-3x	BA554455	IF P.C. Board Comp. (94-5009)	1	2-C18	EC336104	Elect. 100μF 6.3WV	1
2-4x	BA563826	IF P.C. Board Comp. (94-5009)	1	2-C19, 20	EC551441	Ceramic DD600 YM 0.01μF(Z) 50WV	2
2-5x	BA556593	IF P.C. Board Comp. (94-5009)	1	2-C21, 22	EC336216	VFM 330PF(J) 50WV	2
2-6x	BA563837	IF P.C. Board Comp. (94-5009)	1	2-C23	EC450527	Elect. 4.7μF 25WV	1
2-IC1 to 4	EI469967	I.C. LA-1221	4	2-C24	EC336216	VFM 330PF(J) 50WV	1
2-TR1, 2	ET520334	Transistor 2SC922(L)	2	2-C25	EC329771	Elect. 4.7μF 6.3WV	1
2-TR3 to 7	ET380834	Transistor 2SC711(E)	5	2-C26	EC313108	Elect. 1μF 50WV	1
2-TR8 to 11	ET551384	Transistor 2SC839(H)	4	2-C27	EC290531	VFM 100PF(K) 50WV	1
2-D1 to 5	ED428264	Germanium Diode 1N60	5	2-C28, 29	EC551441	Ceramic DD600 YM 0.01μF(Z) 50WV	2
2-D6, 7	ED379855	Germanium Diode 1N60P	2	2-C30	EC313108	Elect. 1μF 50WV	1
2-D8	ED514721	Silicon Diode WG-599	1	2-C31, 32	EC551441	Ceramic DD600 YM 0.01μF(Z) 50WV	2
2-D9 to 13	ED219464	Germanium Diode 1N34A	5	2-C33	EC450527	Elect. 4.7μF 25WV	1
2-T1	BT551406	Trans. 05M-033-1329	1	2-C34, 35	EC492142	Ceramic DD512 0.047μF(YM) 50WV	2
2-T2	EO551395	FM Discr Coil 05M-033-1352B	1	2-C36	EC427948	VFM 10PF(J) 50WV	1
2-T3	EO551417	AM-RF Coil 05M-033-1326	1	2-C37, 38	EC492142	Ceramic DD512 0.047μF(YM) 50WV	2
2-T4	EO551428	AM-OSC Coil 05M-033-1327	1	2-C39	EC250841	Mylar 0.01μF(J) 50WV	1
2-T5	BT379991	Trans. HI-137S(yellow)	1	2-C40	EC443632	VFM 430PF(J) 50WV	1
2-T6	BT380384	Trans. HI-134S(white)	1	2-C41	EC492142	Ceramic DD512 0.047μF(YM) 50WV	1
2-T7	BT443610	Trans. HI-144S(black)	1	2-C43,44,45	EC492142	Ceramic DD512 0.047μF(YM) 50WV	3
2-FL1,2,3	EI539818	Filter SFE-10.7MA5	3	2-C46	EC450527	Elect. 4.7μF 25WV	1
2-FL4	ER380406	Filter BFB 455B-5	1	2-C47 to 51	EC492142	Ceramic DD512 0.047μF(YM) 50WV	5
2-FL4	ER380417	Filter BFB 464-A (US-B)	1	2-C52	EC329850	VFM 220PF(J) 50WV	1
2-L1,2	EO539820	Peaking Coil 2.2μH(K)	2	2-C53, 54	EC492142	Ceramic DD512 0.047μF(YM) 50WV	2
2-VR1	EV380215	Semi-fixed Vol. SR19R 100 kΩ (Solid type)	1	2-C55	EC336104	Elect. 100μF 6.3WV	1
2-VR2	EV551452	Semi-fixed Vol. SR19R 22 kΩ (Solid type)	1	2-C56, 57	EC250841	Mylar 0.01μF(J) 50WV	2
2-7	EI539662	Lapping Post 1x17	20	2-C58	EC450527	Elect. 4.7μF 25WV	1
2-C1, 2, 3	EC551441	Capacitor, Vertical Type Ceramic DD600 YM 0.01μF(Z) 50WV	3				
2-C4	EC368256	Elect. 0.47μF 25WV	1				
2-C5, 6, 7	EC551441	Ceramic DD600 YM 0.01μF(Z) 50WV	3				

When ordering parts, please describe Parts Number, Serial Number, and Model Number in detail.

Symbol No.	Parts No.	Description	Q'ty
Resistor, Stopper Type			
2-R1	ER211667	Carbon RD1/4 100(J)	1
2-R2	ER212681	Carbon RD1/4 330(J)	1
2-R3	ER306887	Carbon RD1/4 15k(J)	1
2-R4	ER212872	Carbon RD1/4 4.3k(J)	1
2-R5	ER212681	Carbon RD1/4 330(J)	1
2-R6	ER211465	Carbon RD1/4 1k(J)	1
2-R7	ER212883	Carbon RD1/4 4.7k(J)	1
2-R8	ER306843	Carbon RD1/4 1.2k(J)	1
2-R9	ER357491	Carbon RD1/4 82k(J)	1
2-R10	ER306887	Carbon RD1/4 15k(J)	1
2-R11, 12	ER212681	Carbon RD1/4 330(J)	2
2-R13	ER304290	Carbon RD1/4 10(J)	1
2-R14	ER212681	Carbon RD1/4 330(J)	1
2-R15	ER371946	Carbon RD1/4 2k(J)	1
2-R16, 17	ER304290	Carbon RD1/4 10(J)	2
2-R18	ER380913	Carbon RD1/4 33(J)	1
2-R19	ER399060	Carbon RD1/4 9.1k(J)	1
2-R20	ER347073	Carbon RD1/4 200(J)	1
2-R21, 22	ER211465	Carbon RD1/4 1k(J)	2
2-R23	ER211667	Carbon RD1/4 100(J)	1
2-R24	ER211858	Carbon RD1/4 12k(J)	1
2-R25	ER349907	Carbon RD1/4 33k(J)	1
2-R26	ER211757	Carbon RD1/4 100k(J)	1
2-R27	ER212264	Carbon RD1/4 22k(J)	1
2-R28	ER430086	Carbon RD1/4 560k(J)	1
2-R29	ER349907	Carbon RD1/4 33k(J)	1
2-R30	ER392850	Carbon RD1/4 390k(J)	1
2-R31	ER336442	Carbon RD1/4 10k(J)	1
2-R32	ER212477	Carbon RD1/4 3.3k(J)	1
2-R33	ER211858	Carbon RD1/4 12k(J)	1
2-R34	ER212681	Carbon RD1/4 330(J)	1
2-R35, 36	ER336442	Carbon RD1/4 10k(J)	2
2-R37	ER357456	Carbon RD1/4 2.2k(J)	1
2-R38	ER211465	Carbon RD1/4 1k(J)	1
2-R39	ER212264	Carbon RD1/4 22k(J)	1
2-R40	ER211667	Carbon RD1/4 100(J)	1
2-R41	ER342933	Carbon RD1/4 27k(J)	1
2-R42	ER212883	Carbon RD1/4 4.7k(J)	1
2-R43	ER357570	Carbon RD1/4 150k(J)	1
2-R44	ER304290	Carbon RD1/4 10(J)	1
2-R45	ER357456	Carbon RD1/4 2.2k(J)	1
2-R46	ER211465	Carbon RD1/4 1k(J)	1
2-R47	ER211757	Carbon RD1/4 100k(J)	1
2-R48	ER304290	Carbon RD1/4 10(J)	1
2-R49	ER211667	Carbon RD1/4 100(J)	1
2-R50, 51	ER211465	Carbon RD1/4 1k(J)	2
2-R52	ER211667	Carbon RD1/4 100(J)	1
2-R53	ER419556	Carbon RD1/4 43k(J)	1
2-R54	ER336442	Carbon RD1/4 10k(J)	1
2-R55	ER407316	Carbon RD1/4 24k(J)	1
2-R56, 57	ER211465	Carbon RD1/4 1k(J)	2
2-R58	ER211667	Carbon RD1/4 100(J)	1
2-R59	ER304402	Carbon RD1/4 470(J)	1
2-R60	ER306887	Carbon RD1/4 15k(J)	1
2-R60	ER349907	Carbon RD1/4 33k(J) (920)	1
2-R61	ER556784	Carbon RD1/4 91k(J)(Insu. type)	1
2-R61	ER213794	Carbon RD1/4 120k(J)(Insu. type) (920)	1
2-R62	ER357456	Carbon RD1/4 2.2k(J)	1
2-R62	ER211465	Carbon RD1/4 1k(J) (920)	1

When ordering parts, please describe Parts Number, Serial Number, and Model Number in detail.

**FIG. 3 PHOTO OF MIC. P.C. BOARD
(94-5021)**

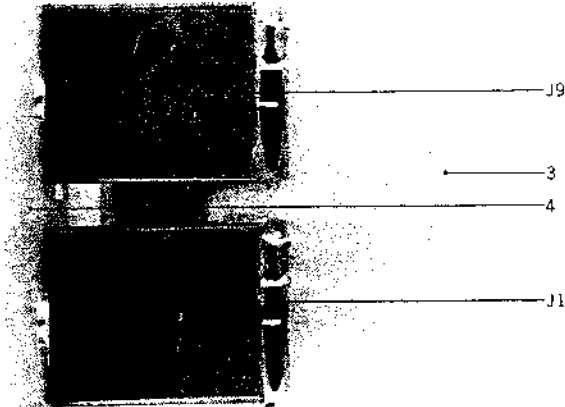

**FIG. 4 PHOTO OF PHONE P.C. BOARD
(94-5022)**



MIC. P.C. BOARD (94-5021) BLOCK

Symbol No.	Parts No.	Description	Q'ty
3-1x	BA554286	Mic. P.C. Board Comp. (94-5021)	1
3-2x	BA556323	Mic. P.C. Board Comp. (94-5021)	1
		(920)	1
3-J1, 9	EJ437310	Mic. Jack 2PMJ1P	2
3-3	EJ539662	Lapping Post 1x17	3
3-4	AZ530728	Jack Mt. Plate	1
3-5	ZW434597	Washer (ALP)D9.3x14.2x0.7t	2
3-6	ZW560237	E Jack Nut	2

PHONE P.C. BOARD (94-5022) BLOCK

Symbol No.	Parts No.	Description	Q'ty
4-1x	BA554275	Phone P.C. Board Comp. (94-5022)	1
4-2x	BA554264	Phone P.C. Board Comp. (94-5022)	1
		(930)	1
4-3x	BA556312	Phone P.C. Board Comp. (94-5022)	1
		(920)	1
4-J20, 21	EJ391083	Mic. Jack 3PMJ1P	2
4-4	EJ539662	Lapping Post 1x17	3
4-5	AZ530728	Jack Mt. Plate	1
4-6	ZW434597	Washer (ALP)D9.3x14.2x0.7t	2
4-7	ZW560237	E Jack Nut	2
		Resistor, Stopper Type	
4-R2, 3	ER429715	Metal Oxide Film 1W 220(J)	2
4-R2, 3	ER515070	Metal Oxide Film 2W 150(K) (920)	2
4-R4, 5	ER429715	Metal Oxide Film 1W 220(J)	2

FIG. 5 PHOTO OF PROTECTOR P.C. BOARD (94-5010)

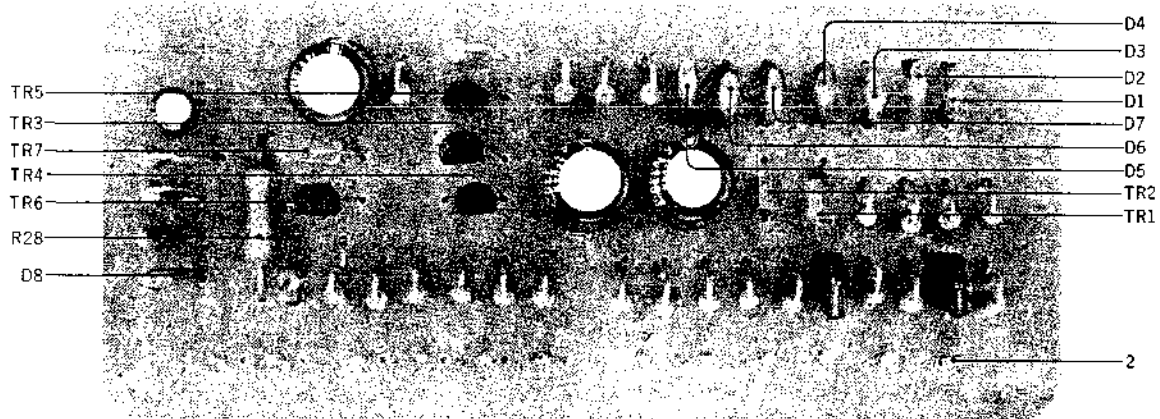

PROTECTOR P.C. BOARD (94-5010) BLOCK

Symbol No.	Parts No.	Description	Q'ty
5-1x	BA554488	Protector P.C. Board Comp. (94-5010)	1
5-TR1, 2	ET552690	Transistor 2SC983(O) (Y)	2
5-TR3, 4	ET398711	Transistor 2SC945(Q) (R)	2
5-TR5	ET552701	Transistor 2SA641(L) (M)	1
5-TR6	ET398711	Transistor 2SC945(Q) (R)	1
5-TR7	ET552688	Transistor 2SC495(O) (Y)	1
5-D1 to 7	ED224548	Silicon Diode 10D2	7
5-D8	ED224526	Silicon Diode 10D1	1
5-2	EJ539662	Lapping Post 1x17	12
Capacitor, Vertical Type			
5-C1, 2	EC368357	Mylar 0.056 μ F(J) 50WV	2
5-C3, 4	EC343236	Elect. 330 μ F 6.3WV	2
5-C5	EC220127	Elect. 100 μ F 16WV	1
5-C6	EC450527	Elect. 4.7 μ F 25WV	1
Resistor, Stopper Type			
5-R1 to 4	ER343078	Carbon RD1/4 2.7k(J)	4
5-R5 to 10	ER306887	Carbon RD1/4 15k(J)	6
5-R11	ER357570	Carbon RD1/4 150k(J)	1
5-R12	ER380913	Carbon RD1/4 33(J)	1
5-R13	ER306887	Carbon RD1/4 15k(J)	1
5-R14	ER357570	Carbon RD1/4 150k(J)	1
5-R15	ER379675	Carbon RD1/4 51k(J)	1
5-R16	ER306887	Carbon RD1/4 15k(J)	1
5-R17	ER349942	Carbon RD1/4 8.2k(J)	1
5-R18	ER443935	Carbon RD1/4 30(J)	1
5-R19	ER357456	Carbon RD1/4 2.2k(J)	1
5-R20, 21	ER399644	Carbon RD1/4 82(J)	2
5-R22	ER357456	Carbon RD1/4 2.2k(J)	1
5-R23	ER379675	Carbon RD1/4 51k(J)	1
5-R24	ER379675	Carbon RD1/4 51k(J)	1
5-R25	ER213030	Carbon RD1/4 5.6k(J)	1
5-R26	ER306887	Carbon RD1/4 15k(J)	1
5-R27	ER352045	Carbon RD1/4 3.9k(J)	1
5-R28	ER429715	Metal Oxide Film 1W 220(J)	1

FIG. 6 PHOTO OF POWER SUPPLY P.C. BOARD (94-5011)

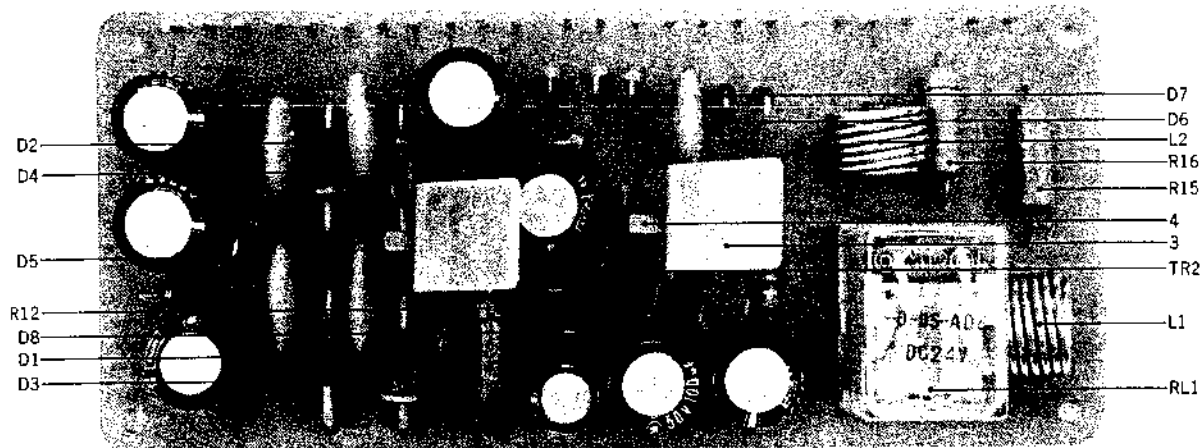

**POWER SUPPLY P.C. BOARD
(94-5011) BLOCK**

Symbol No.	Parts No.	Description	Q'ty
6-1x	BA554545	Power Supply P.C. Board Comp. (94-5011)	1
6-2x	BA575368	Power Supply P.C. Board Comp. (94-5011) (CSA,CEE)	1
6-TR1	ET452531	Transistor 2SD313(E) (F)	1
6-TR2	ET453486	Transistor 2SC711(E) (F)	1
6-TR3	ET452531	Transistor 2SD313(E) (F)	1
6-D1 to 4	ED551700	Power Diode SR3AM-8	4
6-D5, 6, 7	ED224548	Silicon Diode 10D2	3
6-D8	ED539976	Zener Diode WZ-130	1
6-L1, 2	EO551711	Phase Correction Coil 2.2μH	2
6-3	EZ532203	Power Heat-sink Plate	2
6-4	ZS554580	ISO Screw, binding head 3x8	2
6-FR1	ER575256	Fuse/R. FRN 1/2 10K 1A (CSA, CEE)	1
6-RL1	EP325585	Rela / MY2-0-AD6 24V	1
Capacitor, Vertical Type			
6-C1 to 5	EC551160	Ceramic NB821YZ 0.01μF(Z) 1.4kV	1
6-C6	EC220410	Elect. 1000μF 10WV	1
6-C7, 8	EC321221	Elect. 100μF 50WV	2
6-C9	EC372148	Elect. 220μF 35WV	1
6-C10	EC290531	VFM 100PF(K) 50WV	1
6-C11, 12	EC321221	Elect. 100μF 50WV	2
6-C13	EC321208	Elect. 220μF 16WV	1
6-C14	EC339096	Elect. 470μF 16WV	1
Resistor, Stopper Type			
6-R1	ER458730	Carbon RD1/2 33(J) (Insu. type)	1
6-R2	ER452542	Carbon RD1/2 10(J) (Insu. type)	1
6-R3	ER211667	Carbon RD1/4 100(J)	1
6-R4	ER212681	Carbon RD1/4 330(J)	1
6-R5	ER211320	Carbon RD1/4 1.5k(J)	1
6-R6	ER357412	Carbon RD1/4 220(J)	1
6-R7	ER362485	Carbon RD1/4 330k(J)	1
6-R8	ER342933	Carbon RD1/4 27k(J)	1
6-R9	ER212264	Carbon RD1/4 22k(J)	1
6-R10	ER212477	Carbon RD1/4 3.3k(J)	1
6-R11	ER211320	Carbon RD1/4 1.5k(J)	1
6-R12	ER515092	Metal Oxide Film 2W 330(K)	1
6-R13	ER399723	Carbon RD1/4 4.7(J)	1
6-R14	ER212477	Carbon RD1/4 3.3k(J)	1
6-R15	ER551722	Metal Oxide Film 2W 10(K)	1
6-R16	ER551722	Metal Oxide Film 2W 10(K)	1

FIG. 7 PHOTO OF POWER SUPPLY P.C. BOARD (92-5004) (AA-920)

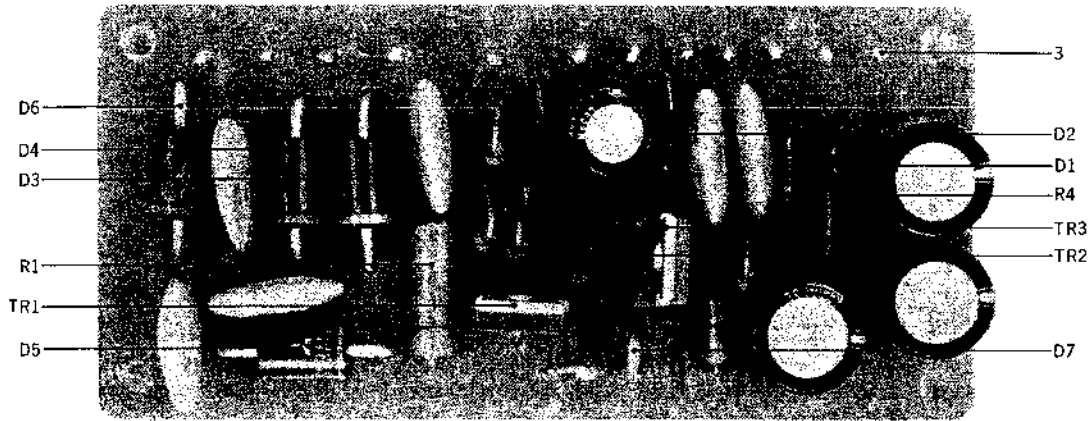

**POWER SUPPLY P.C. BOARD (92-5004)
BLOCK (AA-920)**

Symbol No.	Parts No.	Description	Q'ty
7-1x	BA556424	Power Supply P.C. Board Comp. (92-5004) (920)	1
7-2x	BA564941	Power Supply P.C. Board Comp. (92-5004) (920CSA, CEE)	1
7-TR1	ET556086	Transistor 2SD313(D) (E)	1
7-TR2	ET398711	Transistor 2SC945(Q) (R)	1
7-TR3	ET556086	Transistor 2SD313(D) (E)	1
7-D1, 2	ED224526	Silicon Diode 10D1	2
7-D3 to 6	ED556110	Silicon Diode SR3AM-4	4
7-D7	ED539976	Zener Diode WZ-130	1
7-FR1	ER564412	Fuse/R. FRN 1/2 22(K) 150MA (CSA, CEE)	1
7-3	EJ539662	Lapping Post 1x17	12
Capacitor, Vertical Type			
7-C1 to 6	EC551160	Ceramic NB821YZ 0.01μF(Z) 1.4kV	6
7-C7, 8	EC324538	Elect. 330μF 25WV	2
7-C9	EC321221	Elect. 100μF 50WV	1
7-C10, 11	EC250604	Mylar 0.001μF(K) 50WV	2
7-C12	EC220127	Elect. 100μF 16WV	1
7-C13	EC250604	Mylar 0.001μF(K) 50WV	1
Resistor, Stopper Type			
7-R1	ER490836	Metal Oxide Film 2W 560(K)	1
7-R2	ER556042	Carbon RD1/4 22(J) (Insu. type)	1
7-R3	ER556097	Carbon RD1/4 5.6(J)	1
7-R4	ER449728	Metal Oxide Film 1W 560(K)	1
7-R5, 6	ER349907	Carbon RD1/4 33k(J)	2
7-R7	ER342933	Carbon RD1/4 27k(J)	2
7-R8	ER343078	Carbon RD1/4 2.7k(J)	1

FIG. 8 PHOTO OF EQ. P.C. BOARD (94-5012)

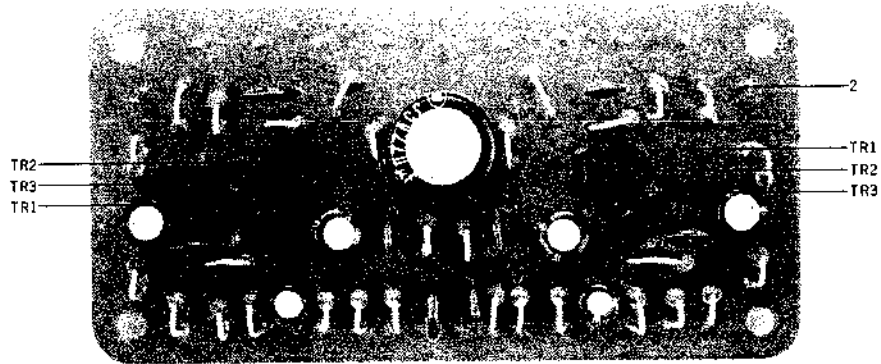

EQ. P.C. BOARD (94-5012) BLOCK

Symbol No.	Parts No.	Description	Q'ty	Symbol No.	Parts No.	Description	Q'ty
8-1x	BA554490	EQ. P.C. Board Comp. (94-5012)	1	8-R1	ER551507	Resistor, Stopper Type Carbon RD1/4 10k(J)NL	2
8-TR1,2,3	ET539987	Transistor 2SC1312(F) (G)	6	8-R2	ER551531	Carbon RD1/4 2.2k(J)NL	2
8-2	EJ539662	Lapping Post 1x17	10	8-R3	ER465276	Carbon RD1/4 270k(J)NL	2
		Capacitor, Vertical Type		8-R4	ER551518	Carbon RD1/4 22k(J)NL	2
8-C1	EC311793	Elect. 0.012μF(J) 50WV	2	8-R5	ER551496	Carbon RD1/4 47k(J)NL	2
8-C2	EC391004	Mylar 0.0033μF(J) 50WV	2	8-R6	ER551474	Carbon RD1/4 1M(J)NL	2
8-C3	EC450527	Elect. 4.7μF 25WV	2	8-R7	ER551553	Carbon RD1/4 510(J)NL	2
8-C4	EC350875	Mylar 0.001μF(J) 50WV	2	8-R8	ER551520	Carbon RD1/4 4.7k(J)NL	2
8-C5	EC331705	Elect. 22μF 16WV	2	8-R9	ER550607	Carbon RD1/4 470k(J)NL	2
8-C6	EC336216	VFM 330PF(J) 50WV	2	8-R10	ER551507	Carbon RD1/4 10k(J)NL	2
8-C7	EC350875	Mylar 0.001μF(J) 50WV	2	8-R11	ER551496	Carbon RD1/4 47k(J)NL	2
8-C8	EC220994	Elect. 10μF 25WV	2	8-R12	ER551542	Carbon RD1/4 1k(J)NL	2
8-C9	EC372148	Elect. 220μF 35WV	1	8-R13	ER551531	Carbon RD1/4 2.2k(J)NL	2
				8-R14	ER551485	Carbon RD1/4 200k(J)NL	2
				8-R15	ER551496	Carbon RD1/4 47k(J)NL	2

FIG. 9 PHOTO OF EQ. P.C. BOARD (92-5003) (AA-920)

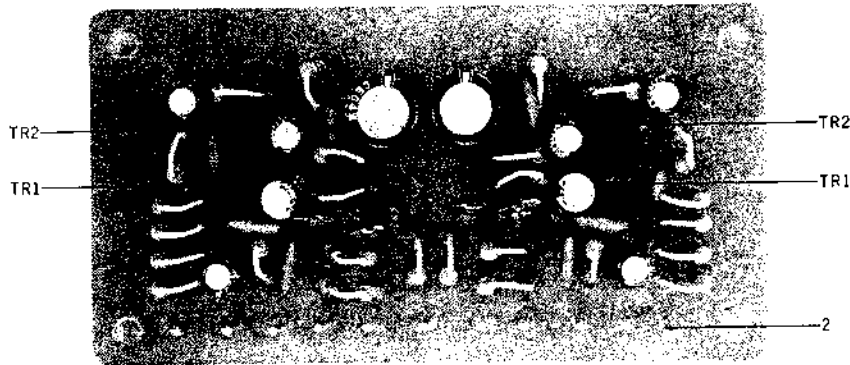

EQ. P.C. BOARD (92-5003) BLOCK (AA-920)

Symbol No.	Parts No.	Description	Q'ty	Symbol No.	Parts No.	Description	Q'ty
9-1x	BA556402	EQ. P.C. Board Comp. (92-5003) (920)	1	9-R1	ER211465	Resistor, Stopper Type Carbon RD1/4 1k(J)	2
9-TR1, 2	ET550754	Transistor 2SC1312(G)	4	9-R2	ER350100	Carbon RD1/4 68k(J)	2
9-2	EJ539662	Lapping Post 1x17	19	9-R3	ER212174	Carbon RD1/4 180k(J)	2
		Capacitor, Vertical Type		9-R4	ER450011	Carbon RD1/4 120k(J)	2
9-C1	EC455354	Elect. 100μF 35WV	2	9-R5	ER213300	Carbon RD1/4 680(J)	2
9-C2	EC320051	Elect. 10μF 16WV	2	9-R6	ER429996	Carbon RD1/4 470k(J)	2
9-C3	EC556018	VFM 30PF(K) 50WV	2	9-R7	ER306887	Carbon RD1/4 15k(J)	2
9-C4, 5	EC290531	VFM 100PF(K) 50WV	4	9-R8	ER343078	Carbon RD1/4 2.7k(J)	2
9-C6	EC556007	Elect. 2.2μF 16WV	2	9-R9	ER357456	Carbon RD1/4 2.2k(J)	2
9-C7	EC368256	Elect. 0.47μF 25WV	2	9-R10	ER361528	Carbon RD1/4 56k(J)	2
9-C8	EC331828	Elect. 3.3μF 25WV	2	9-R11	ER362485	Carbon RD1/4 330k(J)	2
9-C9	EC250841	Mylar 0.01μF(J) 50WV	2	9-R12	ER342933	Carbon RD1/4 27k(J)	2
9-C10	EC379765	Mylar 0.0027μF(J) 50WV	2	9-R13	ER357535	Carbon RD1/4 39k(J)	2
9-C11	EC290531	VFM 100PF(K) 50WV	2				

When ordering parts, please describe Parts Number, Serial Number, and Model Number in detail.

FIG. 10 PHOTO OF MAIN AMP. (94-5013) BLOCK

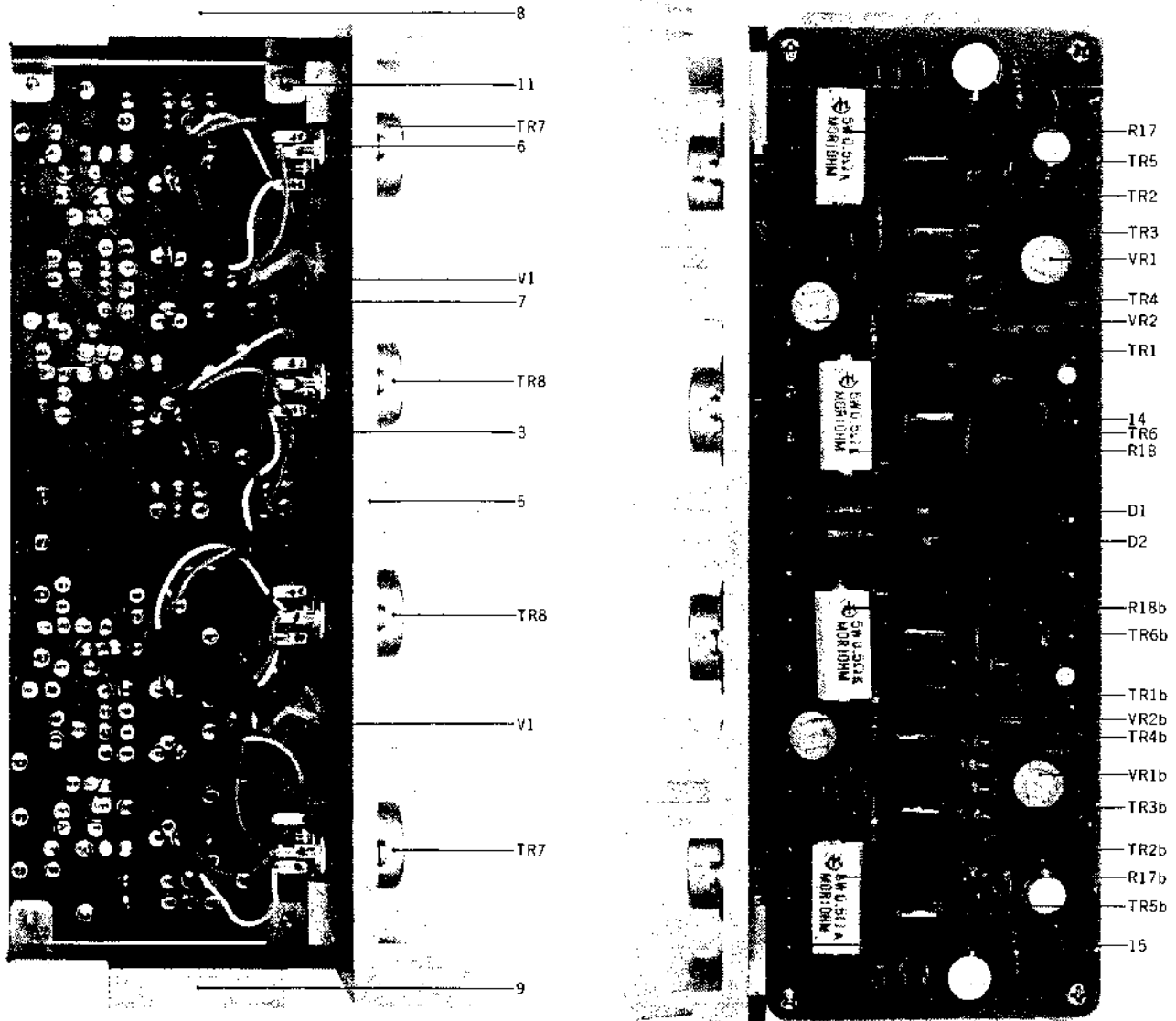

MAIN AMP. (94-5013) BLOCK

Symbol No.	Parts No.	Description	Q'ty
MAIN AMP. BLOCK			
10-1x	BA554512	Main Amp. Block Comp.	1
10-2x	BA554501	Main Amp. Block Comp. (930)	1
10-TR7	ET551665	Transistor 2SC1116(O) (Y)	2
10-TR7	ET551687	Transistor 2SC1403(O) (Y) (930)	2
10-TR8	ET551676	Transistor 2SA747(O) (Y)	2
10-TR8	ET551698	Transistor 2SA745(O) (Y) (930)	2
10-V1	ED551733	Silicon Varistor STV-4H	2
10-3	BA554534	Main Amp. P.C. Board Comp. (94-5013)	1
10-4x	BA554523	Main Amp. P.C. Board Comp. (94-5013) (930)	1
10-5	EZ533531	Heat-sink	1
10-6	EJ551744	TR-11 Socket S2-110B-00 (C type)	4
10-7	ZS447840	Tapping Screw #2 3x8(BR)	2
10-8	AA532181	Heat-sink Mt. Angle A	1
10-9	AA532192	Heat-sink Mt. Angle B	1
10-10x	ZS379405	ISO Screw, binding head 3x6	4
10-11	ZS447772	Tapping Screw #2 3x6(BR)	4
MAIN AMP. P.C. BOARD BLOCK			
10-12x	BA554534	Main Amp. P.C. Board Comp. (94-5013)	1
10-13x	BA554523	Main Amp. P.C. Board Comp. (94-5013) (930)	1
10-TR1, 2	ET561802	Transistor 2SA640(1)	4
10-TR3,4,5	ET551564	Transistor 2SC1124(1) (2)	6
10-TR6	ET551575	Transistor 2SA706-5(1) (2)	2
10-TR6	ET551586	Transistor 2SA706-4(1) (2) (930)	2
10-D1, 2	ED539976	Zener Diode WZ-130	2
10-VR1	EV551643	Semi-fixed Vol. SR19R 330B	2
10-VR2	EV361798	Semi-fixed Vol. SR19R 100B	2
10-14	EJ551654	Lapping Post 1x20	18
10-15	EJ539662	Lapping Post 1x17	11
Capacitor, Vertical Type			
10-C1	EC313108	Elect. 1 μ F 50WV	2
10-C2	EC389024	VFM 82PF(K) 50WV	2
10-C3	EC350717	VFM 390PF(J) 50WV	2
10-C4	EC329782	Elect. 220 μ F 10WV	2
10-C5	EC321221	Elect. 100 μ F 50WV	2
10-C6	EC487394	VFM 47PF(K) 50WV	2
10-C7	EC379170	Mylar 0.1 μ F(J) 50WV	2
10-C8, 9	EC539842	VFM 200PF(K) 50WV	4
10-C10	EC368357	Mylar 0.056 μ F(J) 50WV	2
10-C11	EC539842	VFM 200PF(K) 50WV	2
Resistor, Stopper Type			
10-R1	ER346601	Carbon RD1/4 47k(J)	2
10-R2	ER212477	Carbon RD1/4 3.3k(J)	2
10-R3	ER212883	Carbon RD1/4 4.7k(J)	2
10-R4	ER430020	Carbon RD1/4 13k(J)	2
10-R5	ER324720	Carbon RD1/4 5.6k(J)(Insu. type)	1
10-R6	ER212883	Carbon RD1/4 4.7k(J)	2
10-R7	ER211465	Carbon RD1/4 1k(J)	2
10-R8	ER419556	Carbon RD1/4 43k(J)	2
10-R9	ER324720	Carbon RD1/4 5.6k(J)(Insu.type)	1
10-R10	ER212872	Carbon RD1/4 4.3k(J)	2
10-R11	ER212477	Carbon RD1/4 3.3k(J)	2
10-R12	ER429794	Carbon RD1/4 68(J)	2
10-R13	ER304290	Carbon RD1/4 10(J)	2
10-R14, 15	ER551621	Carbon RD1/2 150(J) (Insu. type)	4
10-R16	ER304290	Carbon RD1/4 10(J)	2
10-R17, 18	ER442653	Cement 5W 0.5(K) (Wire-wound type)	4
10-R19	ER551632	Carbon RD1/2 10(J) (Insu. type)	2

FIG. 11 PHOTO OF MAIN AMP. P.C. BOARD (92-5005) (AA-920)

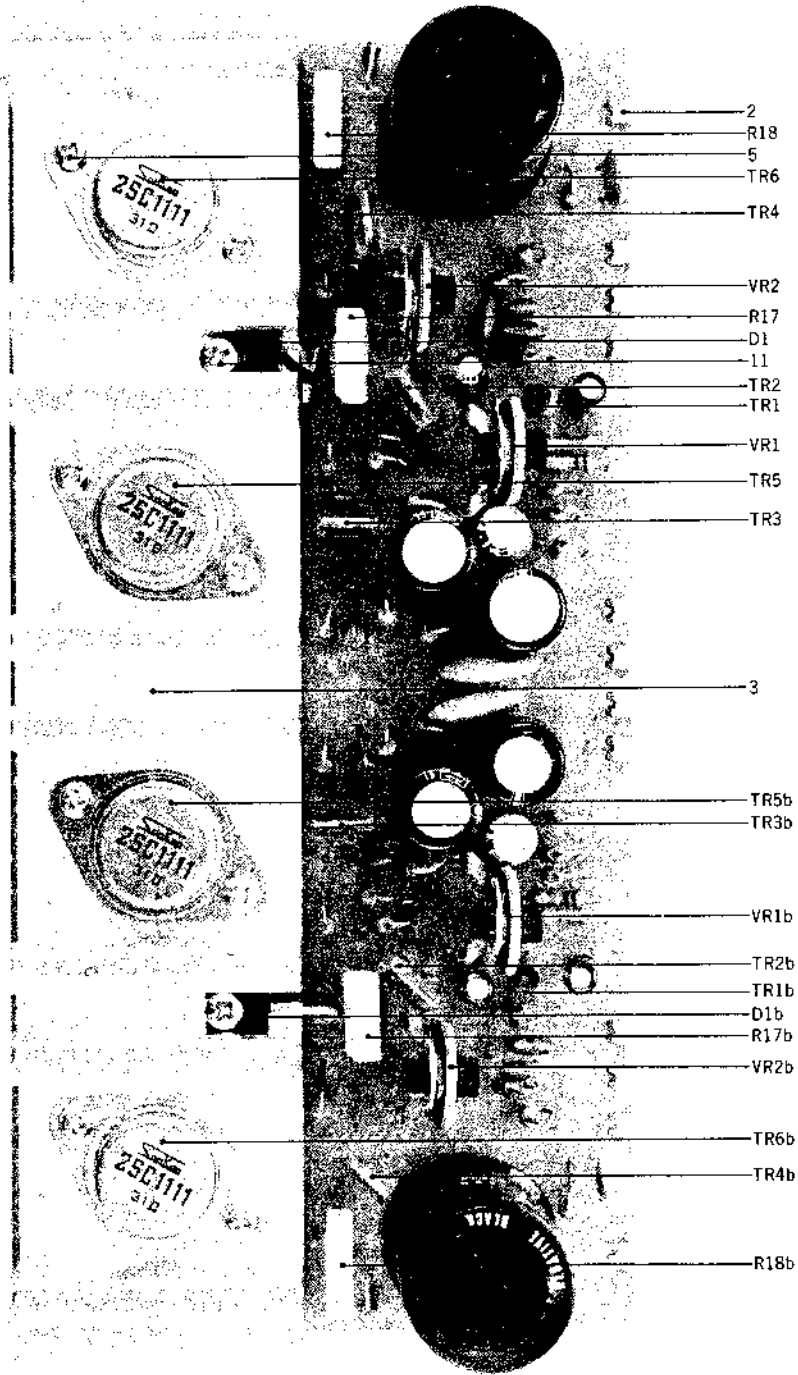

**MAIN AMP. P.C. BOARD (92-5005) BLOCK
(AA-920)**

Symbol No.	Parts No.	Description	Q'ty
11-1x	BA556413	Main Amp. P.C. Board Comp. (92-5005)	1
11-TR1	ET539987	Transistor 2SC1312(F) (G)	2
11-TR2, 3	ET551564	Transistor 2SC1124(1) (2)	4
11-TR4	ET556020	Transistor 2SA706-3(1) (2)	2
11-TR5, 6	ET556648	Transistor 2SC1111(O) (Y)	4
11-D1	ED556514	Varistor STV-3H	2
11-VR1	EV383398	Semi-fixed Vol. V18K3-2 30 kB(4US)	2
11-VR2	EV409858	Semi-fixed Vol. V18K3-2 100B(4US)	2
11-2	EJ550012	Lapping Terminal T5280	12
11-3	EZ542755	Heat-sink B	1
11-4x	AA541552	Transistor Mt. Plate	4
11-5	ZS463454	ISO Screw, binding bead 3x15	8
11-6x	ZW348107	ISO Nut M3	8
11-7x	ZW273778	Earth Lug M3	8
11-8x	ZW259593	Washer (BSP)D3.4x7.8x0.5t	8
11-9x	AA541563	Heat-sink Plate Mt. Parts	2
11-10x	ZS379405	ISO Screw, binding head 3x6	4
11-11	ZS321298	ISO Screw, binding head 3x8	2
11-12x	ZW426622	Washer (SPC)D3.4x7.8x0.5t	2
Capacitor, Vertical Type			
11-C1	EC539943	Elect. 3.3 μ F 50WV	2
11-C2	EC290531	VFM 100PF(K) 50WV	2
11-C3	EC321221	Elect. 100 μ F 50WV	2
11-C4	EC539943	Elect. 3.3 μ F 50WV	2
11-C5	EC321221	Elect. 100 μ F 50WV	2
11-C6	EC290531	VFM 100PF(K) 50WV	2
11-C7	EC220364	Elect. 100 μ F 6.3WV	2
11-C8	EC556176	Elect. 2200 μ F 35WV	2
11-C9	EC487394	VFM 47PF(K) 50WV	2
11-C10	EC384085	Ceramic DB205YZ 0.022 μ F(Z) 50WV	2
11-C11	EC551160	Ceramic NB821YZ 0.01 μ F(Z) 1.4 kWV	2
11-C12	EC357827	VFM 50PF(K) 50WV	2
Resistor, Stopper Type			
11-R1	ER213715	Carbon RD1/4 100k(J) (Insu. type)	2
11-R2	ER329264	Carbon RD1/4 2.2k(J) (Insu. type)	2
11-R3	ER430007	Carbon RD1/4 1.5M(J)	2
11-R4	ER211757	Carbon RD1/4 100k(J)	2
11-R5	ER304402	Carbon RD1/4 470(J)	2
11-R6	ER346544	Carbon RD1/4 3k(J)	2
11-R7	ER433877	Carbon RD1/4 120(J)	2
11-R8	ER466582	Carbon RD1/2 820(J) (Insu. type)	2
11-R9	ER212883	Carbon RD1/4 4.7k(J)	2
11-R10	ER357535	Carbon RD1/4 39k(J)	2
11-R11	ER212477	Carbon RD1/4 3.3k(J)	2
11-R12	ER212016	Carbon RD1/4 150(J)	2
11-R13	ER556042	Carbon RD1/2 22(J) (Insu. type)	2
11-R14	ER212016	Carbon RD1/4 150(J)	2
11-R15	ER556042	Carbon RD1/2 22(J) (Insu. type)	2
11-R16	ER212016	Carbon RD1/4 150(J)	2
11-R17, 18	ER556064	Metal Plate MPC71F2 5W 0.47(K)	4
11-R19	ER306887	Carbon RD1/4 15k(J)	2
11-R20	ER352045	Carbon RD1/4 3.9k(J)	2
11-R21	ER452542	Carbon RD1/2 10(J) (Insu. type)	2

FIG. 12 PHOTO OF TONE CONTROL P.C. BOARD (94-5025)

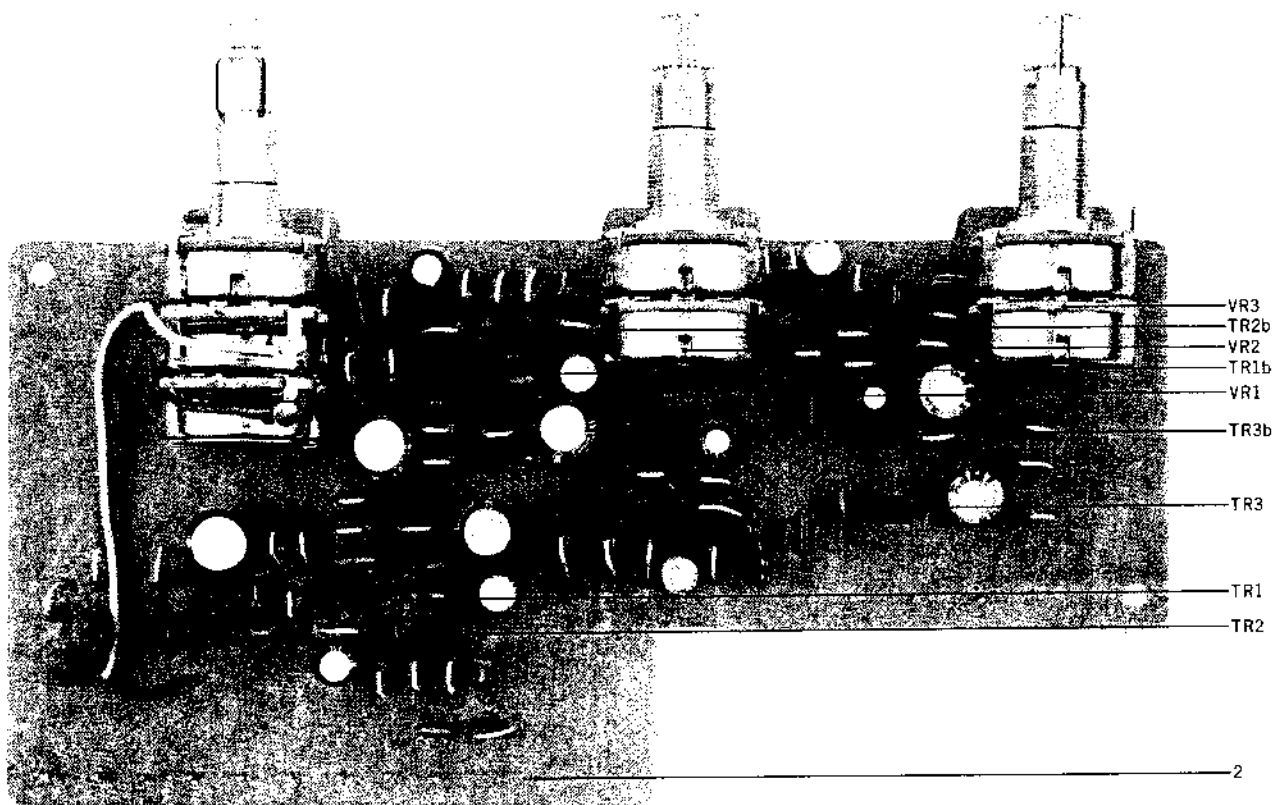

TONE CONTROL P.C. BOARD (94-5025)

BLOCK

Symbol No.	Parts No.	Description	Q'ty	Symbol No.	Parts No.	Description	Q'ty
12-1x	BA554332	Tone Control P.C. Board Comp. (94-5025)	1	Resistor, Stopper Type			
12-TR1	ET539987	Transistor 2SC1312(F) (G)	2	12-R1	ER350100	Carbon RD1/4 68k(J)	2
12-TR2	ET460912	Transistor 2SA640(L) (M)	2	12-R2	ER357535	Carbon RD1/4 39k(J)	2
12-TR3	ET539987	Transistor 2SC1312(F) (G)	2	12-R3	ER362024	Carbon RD1/4 820k(J)	2
12-VR1	EV551226	Co-axial 2-throw Vol., w/pre-set V24L5DPHN 2BL 500kx2	1	12-R4	ER336442	Carbon RD1/4 10k(J)	2
12-VR2, 3	EV551237	Double Vol. V24L5DPHN 1 kB 100kx2 (frictional)	2	12-R5	ER349907	Carbon RD1/4 33k(J)	2
12-2	EJ539662	Lapping Post 1x17	14	12-R6	ER306360	Carbon RD1/4 6.8k(J)	2
		Capacitor, Vertical Type		12-R7	ER336442	Carbon RD1/4 10k(J)	2
12-C1	EC389024	VFM 82PF(K) 50WV	2	12-R8	ER212477	Carbon RD1/4 3.3k(J)	2
12-C2	EC250975	Mylar 0.015μF(J) 50WV	2	12-R9	ER211858	Carbon RD1/4 12k(J)	2
12-C3	EC368357	Mylar 0.056μF(J) 50WV	2	12-R10	ER306683	Carbon RD1/4 1.2k(J)	2
12-C4	EC290531	VFM 100PF(K) 50WV	2	12-R11	ER336442	Carbon RD1/4 10k(J)	2
12-C5	EC329771	Elect. 47μF 6.3WV	2	12-R12	ER306683	Carbon RD1/4 1.2k(J)	2
12-C6	EC474671	VFM 10PF(K) 50WV	2	12-R13, 14	ER213030	Carbon RD1/4 5.6k(J)	4
12-C7	EC357827	VFM 50PF(K) 50WV	2	12-R15	ER429996	Carbon RD1/4 470k(J)	2
12-C8	EC493323	Elect. 1μF 25WV NL	2	12-R16, 17	ER306887	Carbon RD1/4 15k(J)	4
12-C9	EC346735	Elect. 47μF 50WV	2	12-R18	ER336442	Carbon RD1/4 10k(J)	2
12-C10, 11	EC379157	Mylar 0.033μF(J) 50WV	4	12-R19	ER429996	Carbon RD1/4 470k(J)	2
12-C12	EC424708	Mylar 0.0018μF(J) 50WV	2	12-R20	ER211757	Carbon RD1/4 100k(J)	2
12-C13	EC331828	Elect. 3.3μF 25WV	2	12-R21	ER349942	Carbon RD1/4 8.2k(J)	2
12-C14	EC456322	VFM 22PF(K) 50WV	2	12-R22	ER357456	Carbon RD1/4 2.2k(J)	2
12-C15	EC336104	Elect. 100μF 6.3WV	2	12-R23	ER211667	Carbon RD1/4 100(J)	2
12-C16	EC478945	Elect. 2.2μF 25WV NL	2				
12-C17	EC346735	Elect. 47μF 50WV	2				

When ordering parts, please describe Parts Number, Serial Number, and Model Number in detail.

FIG. 13 PHOTO OF TONE CONTROL P.C. BOARD (92-5010) (AA-920)

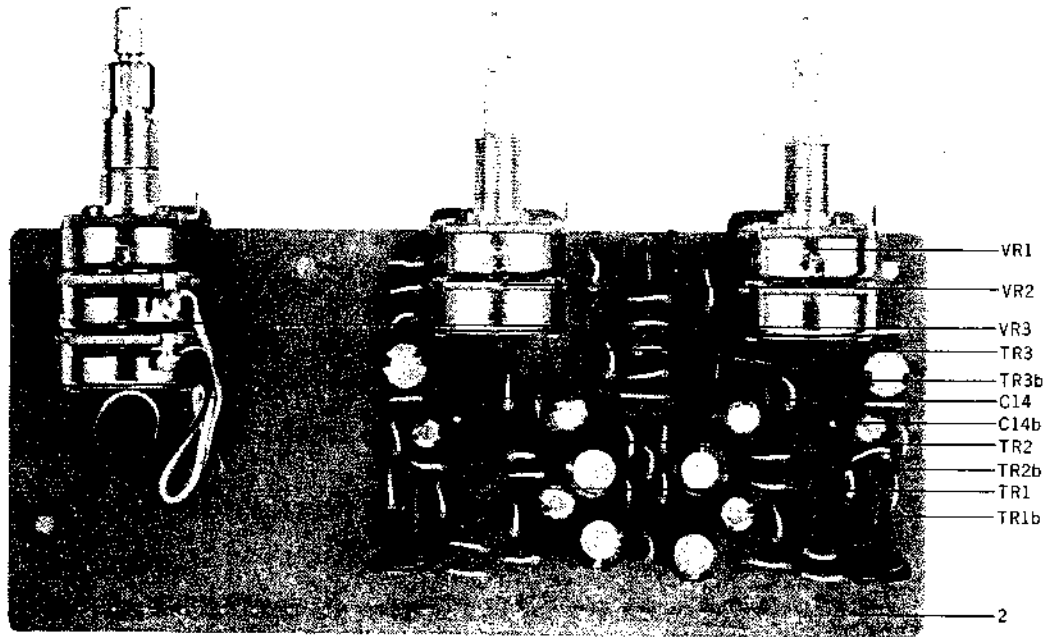

**TONE CONTROL P.C. BOARD (92-5010)
BLOCK (AA-920)**

Symbol No.	Parts No.	Description	Q'ty	Symbol No.	Parts No.	Description	Q'ty
13-1x	BA556345	Tone Control P.C. Board Comp. (92-5010) (920)	1				
13-TR1	ET491051	FET Transistor 2SK30A (GR)	2	13-R1	ER419040	Resistor, Stopper Type Carbon RD1/4 1M(J)	2
13-TR2	ET555952	Transistor 2SA725(G)	2	13-R2	ER380755	Carbon RD1/4 6.2k(J)	2
13-TR3	ET550754	Transistor 2SC1312(G)	2	13-R3	ER306360	Carbon RD1/4 6.8k(J)	2
13-VR1, 2	EV555941	Co-axial 2-throw Vol., w/click V24L5GPHN 1 kB 100kx2	2	13-R4	ER349907	Carbon RD1/4 33k(J)	2
13-VR3	EV551226	Co-axial 2-throw Vol., w/pre-set V24L5DPHN 2BL 500kx2	1	13-R5	ER212883	Carbon RD1/4 4.7k(J)	2
13-2	EJ539662	Lapping Post 1x17	15	13-R6	ER371946	Carbon RD1/4 2k(J)	2
		Capacitor, Vertical Type		13-R7	ER336442	Carbon RD1/4 10k(J)	2
13-C1	EC346735	Elect. 47 μ F 50WV	2	13-R8	ER306843	Carbon RD1/4 1.2k(J)	2
13-C2	EC251291	Mylar 0.1 μ F(K) 50WV	2	13-R9, 10	ER336442	Carbon RD1/4 10k(J)	4
13-C3	EC290531	VFM 100PF(K) 50WV	2	13-R11	ER211465	Carbon RD1/4 1k(J)	2
13-C4	EC290507	VFM 150PF(K) 50WV	2	13-R12	ER336442	Carbon RD1/4 10k(J)	2
13-C5	EC329771	Elect. 47 μ F 6.3WV	2	13-R13, 14	ER212883	Carbon RD1/4 4.7k(J)	4
13-C6	EC450527	Elect. 4.7 μ F 25WV	2	13-R15	ER336442	Carbon RD1/4 10k(J)	2
13-C7, 8	EC379214	Mylar 0.047 μ F(J) 50WV	4	13-R16	ER430086	Carbon RD1/4 560k(J)	2
13-C9	EC250716	Mylar 0.0022 μ F(K) 50WV	2	13-R17	ER450011	Carbon RD1/4 120k(J)	2
13-C10	EC220994	Elect. 10 μ F 25WV	2	13-R18	ER349942	Carbon RD1/4 8.2k(J)	2
13-C11	EC456322	VFM 22PF(K) 50WV	2	13-R19	ER357456	Carbon RD1/4 2.2k(J)	2
13-C12	EC336104	Elect. 100 μ F 6.3WV	2	13-R20	ER211667	Carbon RD1/4 100(J)	2
13-C13	EC346735	Elect. 47 μ F 50WV	2	13-R21	ER212681	Carbon RD1/4 330(J)	2
13-C14	EC497946	Tantalum 0.68 μ F(M) 35WV (DTS type)	2				

FIG. 14 PHOTO OF DIMMER P.C. BOARD (94-5023)

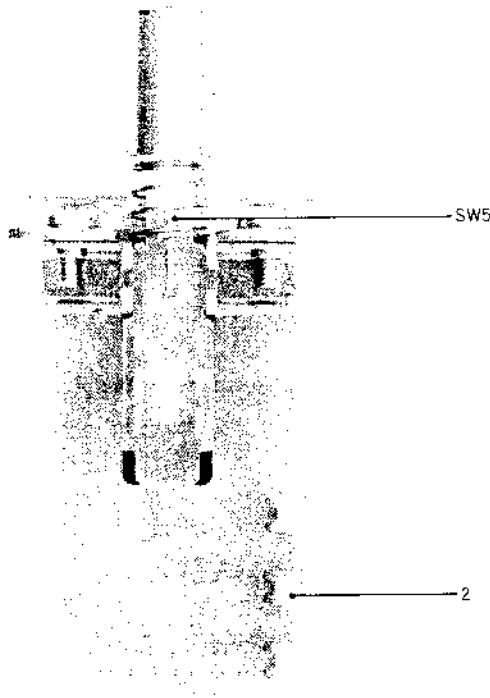

DIMMER P.C. BOARD (94-5023) BLOCK

Symbol No.	Parts No.	Description	Q'ty
14-1x	BA554297	Dimmer P.C. Board Comp. (94-5023)	1
14-SW5	ES551171	Push Switch 1FS-2U-12	1
14-2	EJ550012	Lapping Post T5280	3

FIG. 15 PHOTO OF SWITCH P.C. BOARD (94-5020)

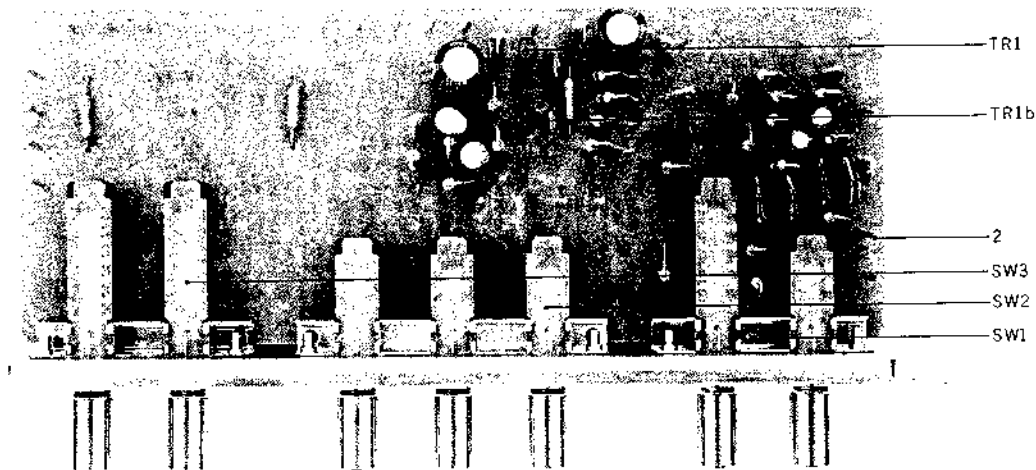

SWITCH P.C. BOARD (94-5020) BLOCK

Symbol No.	Parts No.	Description	Q'ty	Symbol No.	Parts No.	Description	Q'ty
15-1x	BA554310	Switch P.C. Board Comp. (94-5020)	1	Resistor, Stopper Type			
15-TR1	ET539987	Transistor 2SC1312(F) (G)	2	15-R1	ER361528	Carbon RD1/4 56k(J)	2
15-SW1	ES551261	Push Switch 2FS-6U-147	1	15-R2	ER419040	Carbon RD1/4 1M(J)	2
15-SW2	ES539651	Push Switch 3FS-6U-148	1	15-R3	ER346994	Carbon RD1/4 18k(J)	2
15-SW3	ES551272	Push Switch 2FS-8U-70	1	15-R4	ER212174	Carbon RD1/4 180k(J)	2
15-2	EJ539662	Lapping Post 1x17	32	15-R5	ER380711	Carbon RD1/4 220k(J)	2
Capacitor, Vertical Type				15-R6	ER212883	Carbon RD1/4 4.7k(J)	2
15-C1, 2	EC438041	Mylar 0.082μF(J) 50WV	4	15-R7	ER450011	Carbon RD1/4 120k(J)	2
15-C3	EC493323	Elect. 1μF 25WV NL	2	15-R8	ER362485	Carbon RD1/4 330k(J)	2
15-C4	EC413684	Mylar 0.0082μF(J) 50WV	2	15-R9	ER212883	Carbon RD1/4 4.7k(J)	2
15-C5	EC379787	Mylar 0.0039μF(J) 50WV	2	15-R10	ER357456	Carbon RD1/4 2.2k(J)	1
15-C6	EC444374	VFM 20PF(K) 50WV	2	15-R11	ER329264	Carbon RD1/4 2.2k(J) (Insu. type)	1
15-C7	EC478945	Elect. 2.2μF 25WV NL	2	15-R12	ER212883	Carbon RD1/4 4.7k(J)	2
15-C8	EC220151	Elect. 100μF 25WV	2	15-R13	ER349828	Carbon RD1/4 20k(J)	2
				15-R14	ER371946	Carbon RD1/4 2k(J)	2
				15-R15	ER357456	Carbon RD1/4 2.2k(J)	2
				15-R16	ER329264	Carbon RD1/4 2.2k(J) (Insu. type)	2

When ordering parts, please describe Parts Number, Serial Number, and Model Number in detail.

FIG. 16 PHOTO OF SWITCH P.C. BOARD (93-5005) (AA-930)

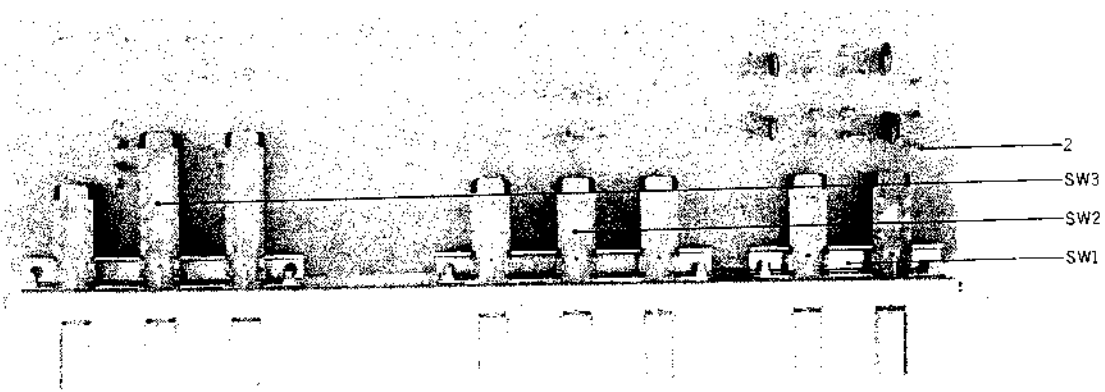

**SWITCH P.C. BOARD (93-5005)
BLOCK (AA-930)**

Symbol No.	Parts No.	Description	Q'ty	Symbol No.	Parts No.	Description	Q'ty
16-1x	BA554308	Switch P.C. Board Comp. (93-5005) (930)	1	Resistor, Stopper Type			
16-SW1	ES551283	Push Switch 2FS-4U-24	1	16-R1	ER430086	Carbon RD1/4 560k(J)	2
16-SW2	ES539651	Push Switch 3FS-6U-148	1	16-R2	ER450011	Carbon RD1/4 120k(J)	2
16-SW3	ES551294	Push Switch 3FS-10U-165	1	16-R3	ER212477	Carbon RD1/4 3.3k(J)	2
16-2	EJ539662	Lapping Post 1x17	29	16-R4	ER429996	Carbon RD1/4 470k(J)	2
		Capacitor, Vertical Type		16-R5	ER211757	Carbon RD1/4 100k(J)	2
16-C1	EC379157	Mylar 0.033 μ F(J) 50WV	2	16-R6	ER211858	Carbon RD1/4 12k(J)	2
16-C2	EC311793	Mylar 0.012 μ F(J) 50WV	2	16-R7	ER212477	Carbon RD1/4 3.3k(J)	2

FIG. 17 PHOTO OF SWITCH P.C. BOARD (92-5011) (AA-920)

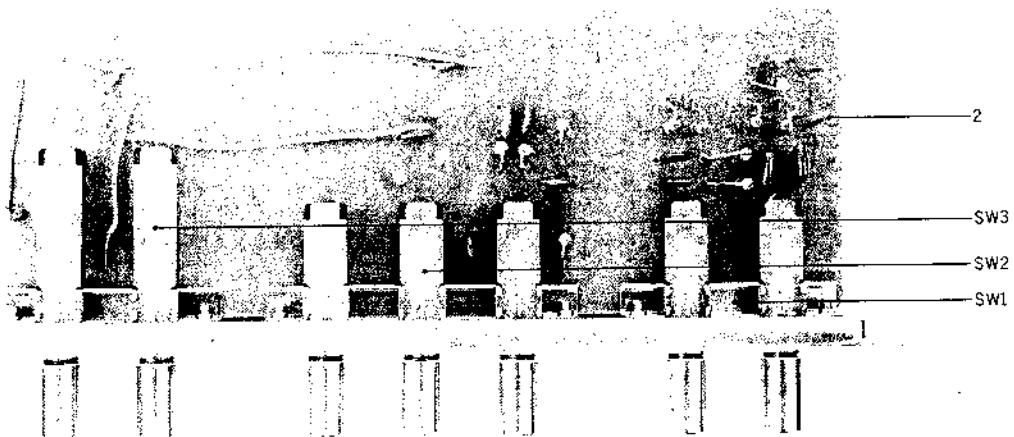

**SWITCH P.C. BOARD (92-5011)
BLOCK (AA-920)**

Symbol No.	Parts No.	Description	Q'ty	Symbol No.	Parts No.	Description	Q'ty
17-1x	BA556334	Switch P.C. Board Comp. (92-5011) (920)	1	Resistor, Stopper Type			
17-SW1	ES551283	Push Switch 2FS-4U-24	1	17-R1, 2	ER211757	Carbon RD1/4 100k(J)	2
17-SW2	ES539651	Push Switch 3FS-6U-148	1	17-R3, 4	ER357491	Carbon RD1/4 82k(J)	2
17-SW3	ES551272	Push Switch 2FS-8U-70	1	17-R5, 6	ER213030	Carbon RD1/4 5.6k(J)	2
17-2	EJ539662	Lapping Post 1x17	27	17-R7, 8	ER429996	Carbon RD1/4 470k(J)	2
		Capacitor, Vertical Type		17-R9, 10	ER350100	Carbon RD1/4 68k(J)	2
17-C1, 2	EC308711	Mylar 0.047 μ F(K) 50WV	2	17-R11, 12	ER342933	Carbon RD1/4 27k(J)	2
17-C3, 4	EC379833	Mylar 0.0082 μ F(K) 50WV	2	17-R13, 14	ER212477	Carbon RD1/4 3.3k(J)	2
17-C5, 6	EC389024	VFM 82PF(K) 50WV	2				
17-C7, 8	EC250997	Mylar 0.015 μ F(K) 50WV	2				

When ordering parts, please describe Parts Number, Serial Number, and Model Number in detail.

**FIG. 18 PHOTO OF DIAL ILLUMINATION
P.C. BOARD (AA-5029)**

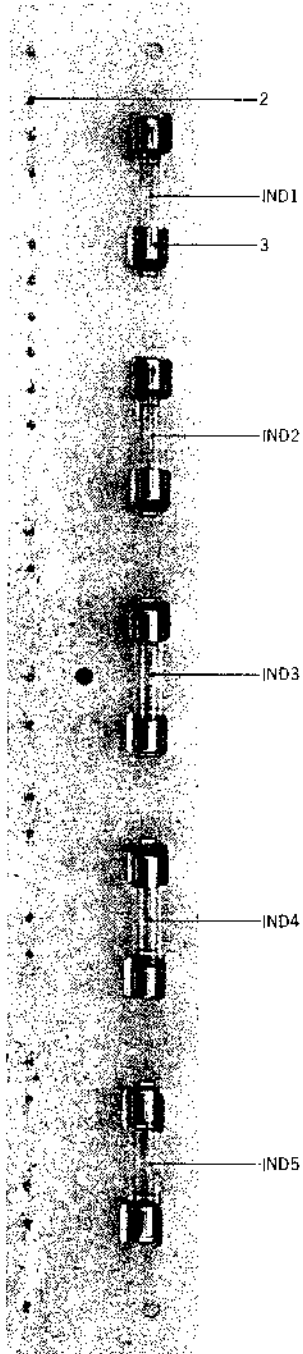

**DIAL ILLUMINATION P.C. BOARD (AA-5029)
BLOCK**

Symbol No.	Parts No.	Description	Q'ty
18-1x	BA554400	Dial Illumination P.C. Board Comp. (AA-5029)	1
18-IND1to5	EL539684	Lamp, Fuse type 8V 0.3A	5
18-2	EJ539662	Lapping Post 1x17	23
18-3	EJ514822	Fuse Holder, P.C. Board	
		S-N5051	10

FIG. 19 PHOTO OF DIAL ILLUMINATION
P.C. BOARD (91-5035) (AA-920)

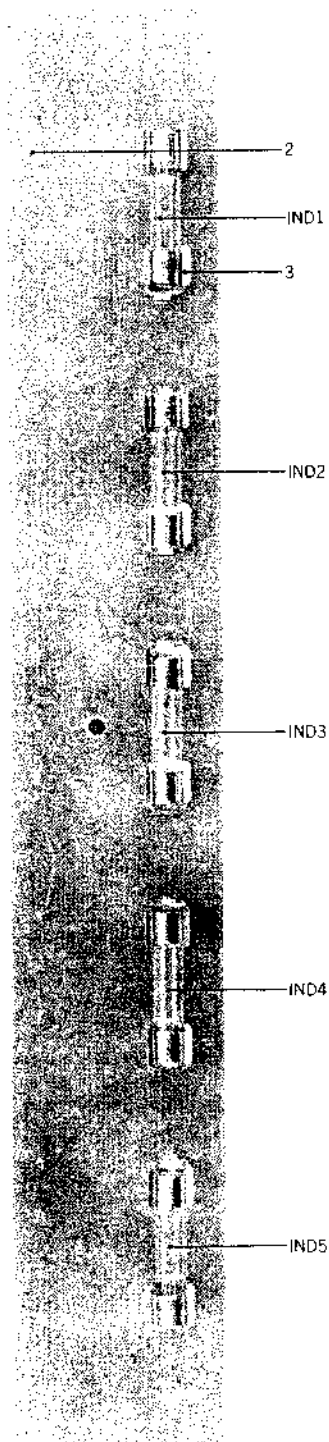

**DIAL ILLUMINATION P.C. BOARD (91-5035)
BLOCK (AA-920)**

Symbol No.	Parts No.	Description	Qty
19-1x	BA550394	Dial Illumination P.C. Board Comp. (91-5035) (920)	1
19-IND1to5	EL539684	Lamp, Fuse type 8V 0.3A	5
19-2	EJ539662	Lapping Post 1x17	15
19-3	EJ514822	Fuse Holder P.C. Board S-N5451	10

FIG. 21 PHOTO OF SCALE PLATE/REAR PANEL BLOCK

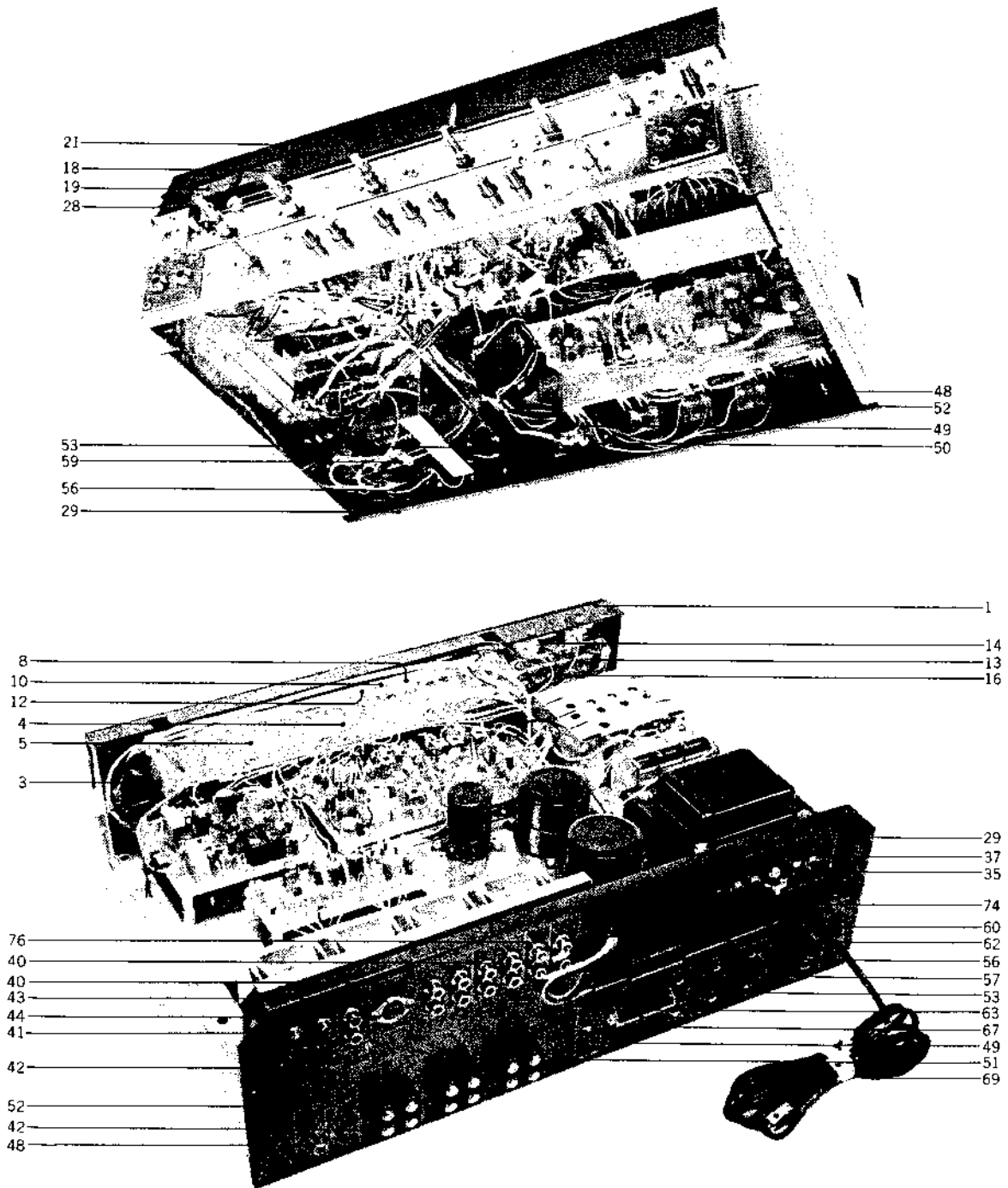

SCALE PLATE/REAR PANEL BLOCK

Ref. No.	Parts No.	Description	Schematic No.	Q'ty	Ref. No.	Parts No.	Description	Schematic No.	Q'ty
SCALE PLATE MT. CHASSIS BLOCK									
21-1	AA533340	Scale Plate Mt. Chassis	94-5026	1	21-59	EC565896	Ceramic/C. DP6600YM		
21-2x	AA530774	Scale Plate Mt. Chassis (920)	91-5020	1			0.01μF(P) 1.4 kWV	24-5-58	1
21-3	AA530785	Lamp Case	91-5021	1	21-60	AA551362	Bar Antenna (in case)	55-1-13	1
21-4	ZS447772	Tapping Screw #2 3x6(BR)		18	21-61x	AA556121	Bar Antenna (920)	55-1-15	1
21-5	BA554400	Dial Illumination P.C. Board			21-62	WM378268	Antenna Support	AA-5552	1
		Comp. (94-5029)		1	21-63	ZS552600	ISO Screw, pan head 4x50		1
21-6x	BA550394	Dial Illumination P.C. Board			21-64x	ZW551373	Washer (Nylon)D4.2x8x0.5t		2
		Comp. (91-5035) (920)		1	21-65x	ZW273914	Spring Washer M4		2
21-7x	SM531336	Name Plate, Pointer	91-5065	1	21-66x	ZW556132	ISO Nut M4		1
21-8	AA533351	Lamp Holder	94-5027	1	21-67	AA530910	Antenna Channel	91-5029	1
21-9x	AA541653	Lamp Holder (920)	92-5012	1	21-68x	ZS447761	Tapping Screw #2 3x6(BR)		
21-10	AA533362	Lamp Holder Case	94-5028	1			(black)		2
21-11x	AA541642	Lamp Holder Case (920)	92-5013	1	21-69	EW540112	AC Cord (CUL) 2.5M	26-3-19	1
21-12	EL550045	Cord Lamp 3 8V 50MA	28-2-30	10	21-70x	EW524845	AC Cord (J) 2.5M (J)	26-3-31	1
21-13	AA530820	Meter Case	91-5025	2	21-71x	EW486797	Power Supply Cord (VDE)		
21-14	AA533384	Meter Mt. Angle	94-5030	1			(WG)	26-3-26	1
21-15x	AA530818	Meter Mt. Angle (920)	91-5024	1	21-72x	EW315448	Australia Cord (3 core)	26-3-11	1
21-16	EJ367986	Fuse Holder 1P AC125V 5A	40-1-8	2	21-73x	EW516600	Power Supply Cord		
21-17x	EL539684	Lamp, Fuse type 8V 0.3A	28-2-27	2			VM-0065 (930-CEE)	26-3-28	1
21-18	EM551248	Signal Meter KL-218L-25	46-1-71	1	21-74	EZ382263	Strain Relief SR-4K-4	2-7-12	2
21-19	EM551250	Tuning Meter KL-218L-27	46-1-70	1	21-75x	EZ246936	Strain Relief SR-6W-1		
21-20x	EM539695	Tuning Meter KL-218L-26					(3 core)	2-7-8	1
		(920)	46-1-68	1	21-76	EJ554578	Short Plug	42-1-66	2
21-21	AA533474	Scale Plate B	94-5039	1					
21-22x	AA533463	Scale Plate A (J)	94-5039	1					
21-23x	AA532023	Scale Plate B (930)	93-5016	1					
21-24x	AA532012	Scale Plate A (930-J)	93-5016	1					
21-25x	AA532034	Scale Plate C (930-A)	93-5016	1					
21-26x	AA541675	Dial Plate A (920)	92-5014	1					
21-27x	AA541686	Dial Plate B (920-J)	92-5014	1					
21-28	EJ556143	Canoe Clip (large)	2-7-35	2					
REAR PANEL BLOCK									
21-29	SP533395	Rear Panel A	94-5032	1					
21-30x	SP533417	Rear Panel C (CSA)	94-5032	1					
21-31x	SP533406	Rear Panel B (930)	94-5032	1					
21-32x	SP582963	Rear Panel D (930-CSA, CEE)	94-5032	1					
21-33x	SP541574	Rear Panel A (920)	92-5015	1					
21-34x	SP541585	Rear Panel B (920-CSA, CEE)	92-5015	1					
21-35	AA510625	5P Antenna Terminal Plate	32-1-29	1					
21-36x	BT444137	Balun Trans. 7.5Ω-300Ω	23-1-129	1					
21-37	ZS553904	ISO Screw, binding head							
		3x8(black)		2					
21-38x	ZW348107	ISO Nut M3		3					
21-39x	ZW273778	Earth Lug M3		2					
21-40	EJ551338	6P Lapping Pin Jack A							
		T-5347(A)	31-1-104	2					
21-41	EJ551340	6P Lapping Pin Jack B							
		T-5347(B)	31-1-102	1					
21-42	ZS570385	ISO Taptight Screw 3x8(pan)		12					
21-43	EJ299305	Jack, 5P Din	31-1-1	1					
21-44	ZS447761	Tapping Screw #2 3x6(BR)							
		(black)		2					
21-45x	ER452777	Carbon/R. RD1/4 160k(J)							
		(Insu. type)	35-9-5	2					
21-46x	ER364994	Carbon/R. RD1/4 39k(J)							
		(Insu. type)	35-9-5	2					
21-47x	ER213873	Carbon/R. RD1/4 150k(J)							
		(Insu. type)	35-9-5	6					
21-48	EV486257	Metal Terminal T-10	32-1-27	1					
21-49	EV461608	Volume V24LSN 25S 1 kΩ	36-2-24	1					
21-50	EZ458673	ST Supporter	AA-745	1					
21-51	ZS552622	ISO Screw, pan head 3x6		2					
21-52	EJ551316	Consent, Speaker P0409	31-1-98	3					
21-53	EJ378944	Socket, AC U/L S-1 9122	31-1-47	3					
21-54x	AA530908	Socket Nut	91-5028	3					
21-55x	ZS393794	ISO Screw, round head 3x8		6					
21-56	EJ233370	Socket (Volt. Selector)							
		S-18010	40-2-3	1					
21-57	ZS552611	ISO Screw, pan head 3x8							
		(black)		2					
21-58x	ER428567	Solid/R. RC1/2 2.2M(K)	35-5-4	1					

When ordering parts, please describe Parts Number, Serial Number, and Model Number in detail.

FIG. 23 PHOTO OF FINAL ASSEMBLY BLOCK

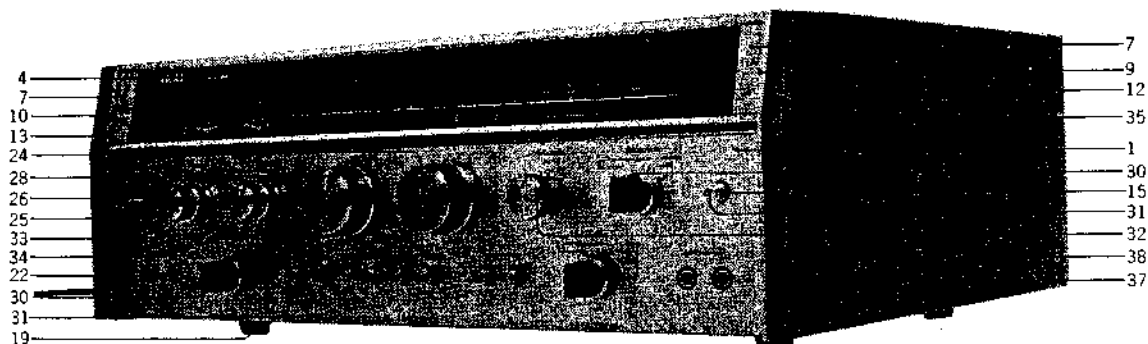

FINAL ASSEMBLY BLOCK

Ref. No.	Parts No.	Description	Schematic No.	Q'ty	Ref. No.	Parts No.	Description	Schematic No.	Q'ty
FRONT PANEL BLOCK									
23-1	SP533441	Front Panel (940)	94-5036	1	23-48x	EF564445	Fuse 3.5A 125V(920-CSA)	39-1-44	2
23-2x	SP531944	Front Panel (930)	93-5008	1	23-49x	EF480892	Fuse 0.8A 125V (920-CSA)	39-1-44	2
23-3x	SP541765	Front Panel (920)	92-5018	1	23-50x	EF564456	Fuse 3.5AT(T type) (920-CEE)		2
23-4	AA531011	Front Plate 4 (940)	91-5044	1	23-51x	AA560092	FM Antenna AFM-1B (5003-03)	55-1-18	1
23-5x	AA531022	Front Plate 5 (930)	91-5044	1	23-52x	AA560081	FM Antenna AFM-1A (5003-04) (J)	55-1-18	1
23-6x	AA531000	Front Plate 3 (920)	91-5044	1					
23-7	AA531134	Fitting 1	91-5045	2					
23-8x	AA530976	Cushion, Front Plate	91-5043	2					
23-9	AA531156	Side Fitting A (right)	91-5046	1					
23-10	AA531167	Side Fitting B (left)	91-5046	1					
23-11x	ZS406416	Tapping Screw #2 3x8 (countersunk)		2					
23-12	AA541517	Side Molding A (right)	91-5082	1					
23-13	AA541528	Side Molding B (left)	91-5082	1					
23-14x	ZS447805	Tapping Screw #2 3x12(BR)		6					
23-15	AA545905	Push Button Bush	98-5061	8					
ASSEMBLY BLOCK									
23-16x	SP533430	Bottom Plate	94-5035	1					
23-17x	SP531202	Bottom Plate (920)	91-5049	1					
23-18x	ZS447772	Tapping Screw #2 3x6(BR)		7					
23-19	SA428714	LM Rubber Foot, w/screw	LM-404	4					
23-20x	ZS463375	Tapping Screw #2 4x15(truss)		4					
23-21x	ZS200676	Tapping Screw #2 3x6 (countersunk)		6					
23-22	EZ436217	Collar, Jack	MC-5006	4					
23-23x	ZW526577	Collar B, Jack (920)	MC-5006	2					
23-24	SK531213	Tuning Knob	91-5050	1					
23-25	SK531314	Power Knob	91-5060	1					
23-26	SK531358	Volume Knob	91-5073	1					
23-27x	ZS446422	ISO Set Screw, hexagon socket 4x8(cup)		1					
23-28	SK531347	Volume Knob Ring	91-5071	1					
23-29x	ZW493312	Washer (Nylon)D6.2x10x1t		1					
23-30	SK531292	Selector Knob	91-5058	3					
23-31	SK531224	Push Button Knob	91-5051	8					
23-32	SK531281	Single Knob	91-5057	1					
23-33	SK531246	Double Knob (upper)	91-5053	2					
23-34	SK531268	Double Knob (lower)	91-5055	2					
23-35	BC533452	Cabinet	94-5038	1					
23-36x	BC531325	Cabinet (920)	91-5061	1					
23-37	ZW548010	Spot Facing Washer	MU-6028	1					
23-38	ZS513775	ISO Screw, binding head 4x15		4					
23-39x	EF378595	Fuse ST-2 4A	39-1-26	1					
23-40x	EF394773	Fuse 2A 250V	39-1-39	1					
23-41x	EF323616	Fuse ST-2 3A	39-1-26	1					
23-42x	EF277424	Fuse ST-4 0.8A (CSA)	39-1-28	2					
23-43x	EF444183	Fuse 1.5A 250V (930,920)	39-1-44	1					
23-44x	EF564491	Fuse 4AT(T type)(930-CEE)		1					
23-45x	EF375647	Fuse 500MAT(T type)(CEE)		3					
23-46x	EF575245	Fuse 5AT (930-CEE)		2					
23-47x	EF277413	Fuse ST-2 2A (920)	39-1-26	3					

When ordering parts, please describe Parts Number, Serial Number, and Model Number in detail.

INDEX

Parts No.	Ref. No. & Symbol No.	Parts No.	Ref. No. & Symbol No.	Parts No.	Ref. No. & Symbol No.	Parts No.	Ref. No. & Symbol No.	Parts No.	Ref. No. & Symbol No.
AA510625	21-35	AF555974	22-32x	EC220994	13-C10	EC379214	13-C7, 8	ED556110	7-D3 to 6
AA530583	22-2x	AF556187	22-33x	EC250604	7-C10,11	EC379765	9-C10	ED556514	11-D1
AA530594	22-6x	AZ530695	22-11x	EC250604	7-C13	EC379787	15-C5	EF277413	23-47x
AA530605	22-4x	AZ530728	3-4	EC250716	13-C9	EC379833	17-C3, 4	EF277424	23-42x
AA530627	22-70	AZ530728	4-5	EC250841	1-C2	EC380621	1-C20,21	EF323616	23-41x
AA530640	22-38x	AZ530730	20-33x	EC250841	2-C39	EC384085	11-C10	EF375647	23-45x
AA530717	20-4x	BA550394	19-1x	EC250841	2-C56,57	EC389024	10-C2	EF378595	23-39x
AA530741	20-40	BA550394	21-6x	EC250841	9-C9	EC389024	12-C1	EF394773	23-40x
AA530774	21-2x	BA554264	4-2x	EC250975	1-C12,13	EC389024	17-C5, 6	EF444183	23-43x
AA530785	21-3	BA554264	20-7x	EC250975	12-C2	EC389474	1-C6	EF480892	23-49x
AA530818	21-15x	BA554275	4-1x	EC250997	17-C7, 8	EC391004	8-C2	EF564445	23-48x
AA530820	21-13	BA554275	20-6	EC251291	13-C2	EC413684	15-C4	EF564456	23-50x
AA530908	21-54x	BA554286	3-1x	EC290507	13-C4	EC424708	12-C12	EF564491	23-44x
AA530910	21-67	BA554286	20-9	EC290531	2-C27	EC427948	2-C36	EF575245	23-46x
AA530954	22-77	BA554297	14-1x	EC290531	6-C10	EC438041	15-C1, 2	EI443744	1-IC1
AA530976	23-8x	BA554297	20-19	EC290531	9-C4,5	EC443632	2-C40	EI469967	2-IC1 to 4
AA531000	23-6x	BA554308	16-1x	EC290531	9-C11	EC443654	2-C8	EI539818	2-FL1, 2,3
AA531011	23-4	BA554308	20-16x	EC290531	11-C2	EC444374	15-C6	EJ233370	21-56
AA531022	23-5x	BA554310	15-1x	EC290531	11-C6	EC450527	2-C23	EJ255093	22-66x
AA531134	23-7	BA554310	20-15	EC290531	12-C4	EC450527	2-C33	EJ299305	21-43
AA531156	23-9	BA554332	12-1x	EC290531	13-C3	EC450527	2-C46	EJ367986	21-16
AA531167	23-10	BA554332	20-49	EC308711	17-C1, 2	EC450527	2-C58	EJ378944	21-53
AA531360	22-78	BA554400	18-1x	EC311793	8-C1	EC450527	5-C6	EJ391083	4-J20, 21
AA531371	22-79	BA554400	21-5	EC311793	16-C2	EC450527	8-C3	EJ437310	3-J1, 9
AA531900	22-58x	BA554455	2-3x	EC313108	2-C26	EC450527	13-C6	EJ510333	22-76x
AA531911	22-25x	BA554477	1-1x	EC313108	2-C30	EC455354	9-C1	EJ514034	22-82
AA531922	22-37x	BA554488	5-1x	EC313108	10-C1	EC456322	12-C14	EJ514607	22-73
AA531933	20-13x	BA554490	8-1x	EC313244	1-C3	EC456322	13-C11	EJ514822	18-3
AA532012	21-24x	BA554501	10-2x	EC320051	9-C2	EC474671	12-C6	EJ514822	19-3
AA532023	21-23x	BA554512	10-1x	EC321208	6-C13	EC478945	12-C16	EJ514822	22-16x
AA532034	21-25x	BA554523	10-4x	EC321221	6-C7,8	EC478945	15-C7	EJ539447	22-62
AA532045	22-1	BA554523	10-13x	EC321221	6-C11, 12	EC487394	10-C6	EJ539458	22-64
AA532056	22-3	BA554534	10-3	EC321221	7-C9	EC487394	11-C9	EJ539662	1-3
AA532078	22-8	BA554534	10-12x	EC321221	10-C5	EC492142	2-C34, 35	EJ539662	2-7
AA532080	22-10	BA554545	6-1x	EC321221	11-C3	EC492142	2-C37, 38	EJ539662	3-3
AA532091	22-24	BA556312	4-3x	EC321221	11-C5	EC492142	2-C41	EJ539662	4-4
AA532102	22-36	BA556312	20-8x	EC324538	7-C7, 8	EC492142	2-C43,44,45	EJ539662	5-2
AA532170	22-71	BA556323	3-2x	EC329771	2-C25	EC492142	2-C47to51	EJ539662	7-3
AA532181	10-8	BA556323	20-10x	EC329771	12-C5	EC492142	2-C53,54	EJ539662	8-2
AA532192	10-9	BA556334	17-1x	EC329771	13-C5	EC493323	12-C8	EJ539662	9-2
AA532214	20-1	BA556334	20-17x	EC329782	10-C4	EC493323	15-C3	EJ539662	10-15
AA532225	20-2x	BA556345	13-1x	EC329850	2-C52	EC497946	13-C14	EJ539662	12-2
AA532236	20-12	BA556345	24-50x	EC331705	8-C5	EC539842	10-C8, 9	EJ539662	13-2
AA532653	20-18x	BA556402	9-1x	EC331828	1-C1	EC539842	10-C11	EJ539662	15-2
AA533338	20-32	BA556413	11-1x	EC331828	1-C4	EC539943	11-C1	EJ539662	16-2
AA533340	21-1	BA556424	7-1x	EC331828	9-C8	EC539943	11-C4	EJ539662	17-2
AA533351	21-8	BA556593	2-5x	EC331828	12-C13	EC551002	22-56	EJ539662	18-2
AA533362	21-10	BA556604	1-2x	EC336104	2-C18	EC551013	22-55	EJ539662	19-2
AA533384	21-14	BA557458	2-1x	EC336104	2-C55	EC551024	22-57x	EJ539662	22-17x
AA533428	22-60	BA563826	2-4x	EC336104	12-C15	EC551160	6-C1 to 5	EJ549652	22-22x
AA533463	21-22x	BA563837	2-6x	EC336104	13-C12	EC551160	7-C1 to 6	EJ549674	22-23x
AA533474	21-21	BA563848	2-2x	EC336216	2-C21,22	EC551160	11-C11	EJ550012	11-2
AA541517	23-12	BA564941	7-2x	EC336216	2-C24	EC551160	20-31x	EJ550012	14-2
AA541528	23-13	BA575368	6-2x	EC336216	8-C6	EC551441	2-C1,2,3	EJ551035	22-63
AA541552	11-4x	BC531325	23-36x	EC337500	1-C10,11	EC551441	2-C5,6,7	EJ551046	22-65x
AA541563	11-9x	BC533452	23-35	EC339096	1-C5	EC551441	2-C9 to 17	EJ551057	22-74
AA541642	21-11x	BF530763	20-43	EC339096	6-C14	EC551441	2-C19, 20	EJ551316	21-52
AA541653	21-9x	BT379991	2-T5	EC339096	22-67	EC551441	2-C28, 29	EJ551338	21-40
AA541675	21-26x	BT380384	2-T6	EC343236	5-C3, 4	EC551441	2-C31, 32	EJ551340	21-41
AA541686	21-27x	BT443610	2-T7	EC346735	12-C9	EC551463	1-C16, 17	EJ551654	10-14
AA541732	22-72x	BT444137	21-36x	EC346735	12-C17	EC555996	22-59x	EJ551744	10-6
AA541743	22-61x	BT550980	22-44	EC346735	13-C1	EC556007	9-C6	EJ552778	22-80
AA544768	22-86x	BT550991	22-46x	EC350706	11-C7	EC556018	9-C3	EJ554578	21-76
AA545905	23-15	BT551406	2-T1	EC350706	1-C7	EC556176	11-C8	EJ554578	22-81
AA547380	20-5x	BT555985	22-49x	EC350706	1-C18, 19	EC565896	21-59	EJ556143	21-28
AA549663	22-21x	BT564423	22-51x	EC350717	10-C3	ED219464	1-D1, 2	EJ561227	22-19x
AA551362	21-60	BT564434	22-50x	EC350875	8-C4	ED219464	2-D9 to 13	EJ561227	22-84x
AA556121	21-61x	BT575098	22-48x	EC350875	8-C7	ED224526	5-D8	EJ582941	22-18x
AA560081	23-52x	BT575100	22-47x	EC357827	11-C12	ED224526	7-D1, 2	EL539684	18-IND1 to 5
AA560092	23-51x	BT575111	22-45x	EC357827	12-C7	ED224526	22-68x	EL539684	19-IND1 to 5
AA582917	22-12x	EA549448	22-87x	EC368256	2-C4	ED224548	5-D1 to 7	EL539684	21-17x
AA582952	20-3x	EA582930	22-15x	EC368256	9-C7	ED224548	6-D5,6,7	EL550045	21-12
AA583165	22-13x	EC220127	5-C5	EC368357	5-C1, 2	ED379855	2-D6, 7	EM539695	21-20x
AF444194	22-31x	EC220127	7-C12	EC368357	10-C10	ED428264	2-D1 to 5	EM551248	21-18
AF448345	22-30x	EC220151	15-C8	EC372148	12-C3	ED514721	2-D8	EM551250	21-19
AF550956	22-27x	EC220364	11-C7	EC372148	6-C9	ED539976	6-D8	EO443766	1-L1
AF550967	22-26	EC220410	6-C6	EC372148	8-C9	ED539976	7-D7	EO443777	1-L2
AF550978	22-29x	EC220432	1-C8, 9	EC379157	12-C10,11	ED539976	10-D1, 2	EO539820	2-L1,2
AF554567	22-28	EC220432	1-C14, 15	EC379157	16-C1	ED551700	6-D1 to 4	EO551395	2-T2
		EC220994	8-C8	EC379170	10-C7	ED551733	10-V1	EO551417	2-T3

INDEX

Parts No.	Ref. No. & Symbol No.	Parts No.	Ref. No. & Symbol No.	Parts No.	Ref. No. & Symbol No.	Parts No.	Ref. No. & Symbol No.	Parts No.	Ref. No. & Symbol No.
EO551428	2-T4	ER213030	12-R13, 14	ER357456	2-R37	ER458730	6-R1	ET551676	10-TR8
EO551711	6-L1, 2	ER213030	17-R5, 6	ER357456	2-R45	ER465276	8-R3	ET551687	10-TR7
EP325585	6-RL1	ER213300	9-R5	ER357456	2-R62	ER466582	11-R8	ET551698	10-TR8
ER211320	6-R5	ER213715	11-R1	ER357456	5-R19	ER490836	7-R1	ET552688	5-TR7
ER211320	6-R11	ER213794	2-R61	ER357456	5-R22	ER496214	1-R3	ET552690	5-TR1, 2
ER211465	1-R8	ER213873	21-47x	ER357456	9-R9	ER496214	1-R6	ET552701	5-TR5
ER211465	1-R14, 15	ER304290	2-R13	ER357456	12-R22	ER512201	1-FL1, 2	ET552870	1-TR1
ER211465	1-R29, 30	ER304290	2-R16, 17	ER357456	13-R19	ER515070	4-R2, 3	ET555952	13-TR2
ER211465	2-R6	ER304290	2-R44	ER357456	15-R10	ER515092	6-R12	ET556020	11-TR4
ER211465	2-R21, 22	ER304290	2-R48	ER357456	15-R15	ER550607	8-R9	ET556086	7-TR1
ER211465	2-R38	ER304290	10-R13	ER357491	1-R2	ER551474	8-R6	ET556086	7-TR3
ER211465	2-R46	ER304290	10-R16	ER357491	1-R5	ER551485	8-R14	ET556648	11-TR5, 6
ER211465	2-R50, 51	ER304402	2-R59	ER357491	2-R9	ER551496	8-R5	ET561802	10-TR1, 2
ER211465	2-R56, 57	ER304402	11-R5	ER357491	17-R3, 4	ER551496	8-R11	EV361798	10-VR2
ER211465	2-R62	ER306360	12-R6	ER357535	9-R13	ER551496	8-R15	EV380215	2-VR1
ER211465	9-R1	ER306360	13-R3	ER357535	11-R10	ER551507	8-R1	EV383398	11-VR1
ER211465	10-R7	ER306843	2-R8	ER357535	12-R2	ER551507	8-R10	EV409858	11-VR2
ER211465	13-R11	ER306843	12-R10	ER357570	2-R43	ER551518	8-R4	EV461608	21-49
ER211667	2-R1	ER306843	12-R12	ER357570	5-R11	ER551520	8-R8	EV486257	21-48
ER211667	2-R23	ER306843	13-R8	ER357570	5-R14	ER551531	8-R2	EV551204	20-48
ER211667	2-R40	ER306887	2-R3	ER361528	9-R10	ER551531	8-R13	EV551226	12-VR1
ER211667	2-R49	ER306887	2-R10	ER361528	15-R1	ER551542	8-R12	EV551226	13-VR3
ER211667	2-R52	ER306887	2-R60	ER362024	12-R3	ER551553	8-R7	EV551237	12-VR2, 3
ER211667	2-R58	ER306887	5-R5 to 10	ER362485	6-R7	ER551621	10-R14, 15	EV551452	2-VR2
ER211667	6-R3	ER306887	5-R13	ER362485	9-R11	ER551722	6-R15	EV551643	10-VR1
ER211667	12-R23	ER306887	5-R16	ER362485	15-R8	ER551722	6-R16	EV555941	13-VR1, 2
ER211667	13-R20	ER306887	5-R26	ER364994	21-46x	ER556042	7-R2	EW315448	21-72x
ER211757	2-R26	ER306887	9-R7	ER371946	1-R22, 23	ER556042	11-R13	EW486797	21-71x
ER211757	2-R47	ER306887	11-R19	ER371946	2-R15	ER556042	11-R15	EW516600	21-73x
ER211757	11-R4	ER306887	12-R16, 17	ER371946	13-R6	ER556064	11-R17, 18	EW524845	21-70x
ER211757	12-R20	ER324720	10-R5	ER371946	15-R14	ER556097	7-R3	EWS40112	21-69
ER211757	16-R5	ER324720	10-R9	ER379675	5-R15	ER551632	10-R19	EZ246936	21-75x
ER211757	17-R1, 2	ER329264	11-R2	ER379675	5-R23	ER556784	2-R61	EZ382263	21-74
ER211858	1-R27, 28	ER329264	15-R10	ER379675	5-R24	ER564412	7-FR1	EZ436217	23-22
ER211858	2-R24	ER329264	15-R16	ER380406	2-FL4	ER575256	6-FR1	EZ458673	21-50
ER211858	2-R33	ER336442	1-R7	ER380417	2-FL4	ES445050	20-27x	EZ532203	6-3
ER211858	12-R9	ER336442	2-R31	ER380711	1-R16 to 19	ES468437	20-24	EZ533531	10-5
ER211858	16-R6	ER336442	2-R35, 36	ER380711	15-R5	ES468448	20-25x	EZ542755	11-3
ER212016	11-R12	ER336442	2-R54	ER380755	13-R2	ES513922	1-SW1	MH547391	20-28x
ER212016	11-R14	ER336442	12-R4	ER380913	2-R18	ES539651	15-SW2	MR443136	22-43x
ER212016	11-R16	ER336442	12-R7	ER380913	5-R12	ES539651	16-SW2	MR530651	20-34
ER212174	9-R3	ER336442	12-R11	ER392850	2-R30	ES539651	17-SW2	MR530651	22-39
ER212174	15-R4	ER336442	12-R18	ER399060	2-R19	ES551136	20-20	MR530662	20-36
ER212264	1-R29, 30	ER336442	13-R7	ER399644	5-R20, 21	ES551147	20-21x	MR530662	22-41x
ER212264	2-R27	ER336442	13-R9, 10	ER399723	6-R13	ES551158	20-23	MR530706	22-34
ER212264	2-R39	ER336442	13-R12	ER307316	2-R55	ES551171	14-SW5	MS530752	20-38
ER212264	6-R9	ER336442	13-R15	ER419040	1-R4	ES551193	20-45	MZ229138	22-75
ER212477	2-R32	ER342933	2-R41	ER419040	13-R1	ES551261	15-SW1	MZ546625	22-20x
ER212477	6-R10	ER342933	6-R8	ER419040	15-R2	ES551272	15-SW3	MZ546625	22-85x
ER212477	6-R14	ER342933	7-R7	ER419556	2-R53	ES551272	17-SW3	SA428714	23-19
ER212477	10-R2	ER342933	9-R12	ER419556	10-R8	ES551283	16-SW1	SK531213	23-24
ER212477	10-R11	ER342933	17-R11, 12	ER428567	21-58x	ES551283	17-SW1	SK531224	23-31
ER212477	11-R11	ER343078	1-R9, 10	ER429715	4-R2, 3	ES551294	16-SW3	SK531246	23-33
ER212477	12-R8	ER343078	5-R1 to 4	ER429715	4-R4, 5	ES556154	20-46x	SK531268	23-34
ER212477	16-R3	ER343078	7-R8	ER429715	5-R28	ES561835	20-26x	SK531281	23-32
ER212477	16-R7	ER343078	9-R8	ER429794	10-R12	ET380834	2-TR3 to 7	SK531292	23-30
ER212477	17-R13, 14	ER346544	11-R6	ER429996	9-R6	ET398711	5-TR3, 4	SK531314	23-25
ER212681	1-R24	ER346601	1-R12, 13	ER429996	12-R15	ET398711	5-TR6	SK531347	23-28
ER212681	2-R2	ER346601	1-R27, 28	ER429996	12-R19	ET398711	7-TR2	SK531358	23-26
ER212681	2-R5	ER346601	10-R1	ER429996	16-R4	ET452531	6-TR1	SM531336	21-7x
ER212681	2-R11, 12	ER346994	1-R1	ER429996	17-R7, 8	ET452531	6-TR3	SP531202	23-17x
ER212681	2-R14	ER346994	15-R3	ER430007	11-R3	ET453486	1-TR2, 3	SP531944	23-2x
ER212681	2-R34	ER347073	2-R20	ER430007	15-R11	ET453486	6-TR2	SP533395	21-29
ER212681	6-R4	ER349828	15-R13	ER430020	10-R4	ET460912	12-TR2	SP533406	21-31x
ER212681	13-R21	ER349907	2-R25	ER430086	2-R28	ET491051	13-TR1	SP533417	21-30x
ER212872	2-R4	ER349907	2-R29	ER430086	13-R16	ET520334	2-TR1, 2	SP533430	23-16x
ER212872	10-R10	ER349907	2-R60	ER430086	16-R1	ET539987	1-TR4, 5	SP533441	23-1
ER212883	1-R20, 21	ER349907	7-R5, 6	ER430255	22-69x	ET539987	8-TR1, 2, 3	SP541574	21-33x
ER212883	1-R25, 26	ER349907	12-R5	ER433877	11-R7	ET539987	11-TR1	SP541585	21-34x
ER212883	2-R7	ER349907	13-R4	ER440921	20-47x	ET539987	12-TR1	SP541765	23-3x
ER212883	2-R42	ER349942	5-R17	ER442653	10-R17, 18	ET539987	12-TR3	SP582963	21-32x
ER212883	10-R3	ER349942	12-R21	ER443935	5-R18	ET539987	15-TR1	WM378268	21-62
ER212883	10-R6	ER349942	13-R18	ER449728	7-R4	ET550754	9-TR1, 2	ZG549011	22-35
ER212883	11-R9	ER350100	9-R2	ER450011	9-R4	ET550754	13-TR3	ZS200676	23-21x
ER212883	13-R5	ER350100	12-R1	ER450011	13-R17	ET551384	2-TR8 to 11	ZS321298	11-11
ER212883	13-R13, 14	ER350100	17-R9, 10	ER450011	15-R7	ET551564	10-TR3, 4, 5	ZS371856	20-14
ER212883	15-R6	ER352045	5-R27	ER450011	16-R2	ET551564	11-TR2, 3	ZS371856	22-14x
ER212883	15-R9	ER352045	11-R20	ER452542	6-R2	ET551575	10-TR6	ZS379405	10-10x
ER212883	15-R12	ER357412	6-R6	ER452542	11-R21	ET551586	10-TR6	ZS379405	11-10x
ER213030	5-R25	ER357456	1-R11	ER452777	21-45x	ET551665	10-TR7	ZS379405	22-9x

INDEX

Parts No.	Ref. No. & Symbol No.	Parts No.	Ref. No. & Symbol No.	Parts No.	Ref. No. & Symbol No.	Parts No.	Ref. No. & Symbol No.
ZS393794	21-55x						
ZS406416	23-11x						
ZS446422	23-27x						
ZS447761	21-44						
ZW447761	21-68x						
ZS447761	22-83						
ZS447772	10-11						
ZS447772	20-11						
ZS447772	21-4						
ZS447772	22-7						
ZS447772	23-18x						
ZS447805	23-14x						
ZS447840	10-7						
ZS462936	20-44x						
ZS463375	23-20x						
ZS463454	11-5						
ZS513775	23-38						
ZS552622	21-51						
ZS530673	20-37						
ZS530673	22-40						
ZS530684	20-35						
ZS530684	22-42x						
ZS552600	21-63						
ZS552611	21-57						
ZS553904	21-37						
ZS554580	6-4						
ZS570385	21-42						
ZW259593	11-8x						
ZW260122	20-39x						
ZW273745	20-30x						
ZW273778	11-7x						
ZW273778	21-39x						
ZW273881	22-54x						
ZW273914	21-65x						
ZW273914	22-52x						
ZW348107	11-6x						
ZW348107	20-29x						
ZW348107	21-38x						
ZW426622	11-12x						
ZW434597	3-5						
ZW434597	4-6						
ZW493312	23-29x						
ZW510660	22-53x						
ZW526577	23-23x						
ZW539583	20-42						
ZW548010	23-37						
ZW551182	20-41x						
ZW551373	21-64x						
ZW556132	21-66x						
ZW560237	3-6						
ZW560237	4-7						

SECTION 3

SCHEMATIC DIAGRAM

1. AA-940 SCHEMATIC DIAGRAM
2. AA-930 SCHEMATIC DIAGRAM
3. AA-920 SCHEMATIC DIAGRAM

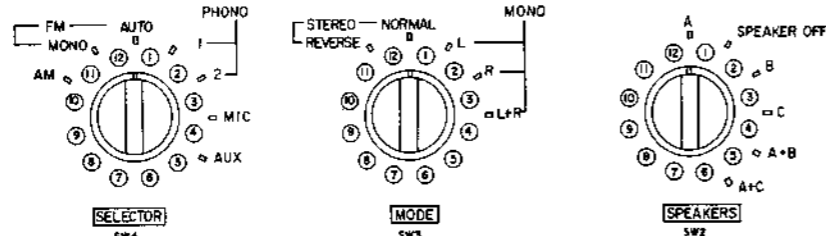
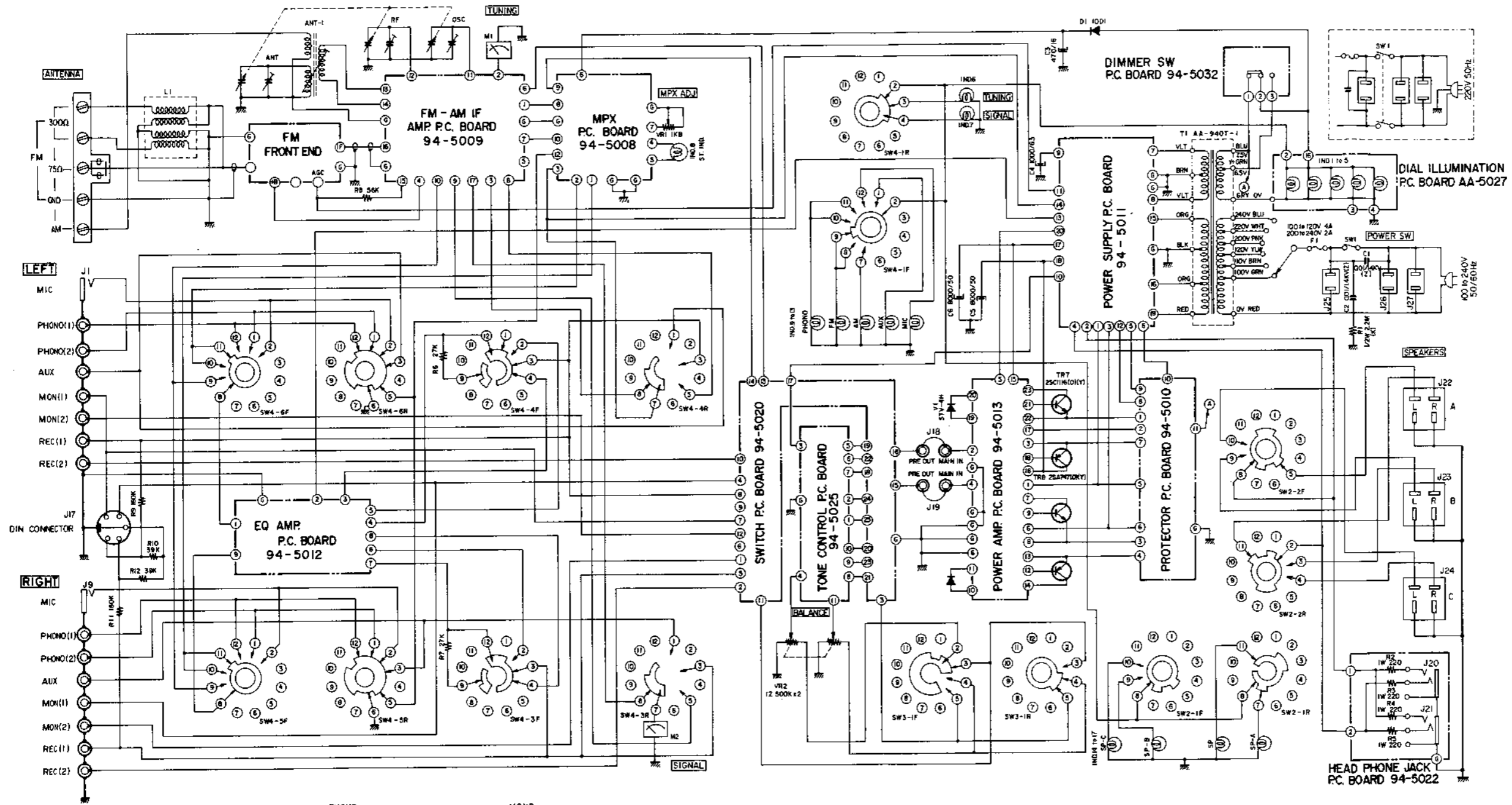

NOTE
UNLESS OTHERWISE SPECIFIED
ALL RESISTORS IN Ω 1/4W(Ω)
ALL CAPACITORS IN μF 50V(V)
POWER SWITCH AND SOCKET ARE DIFFERENT
ACCORDING TO AREA.

AA-940
SCHEMATIC DIAGRAM
1462212A

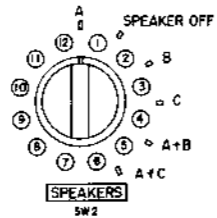
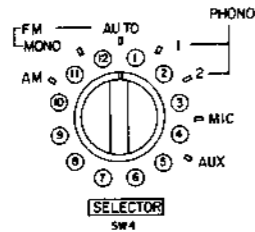
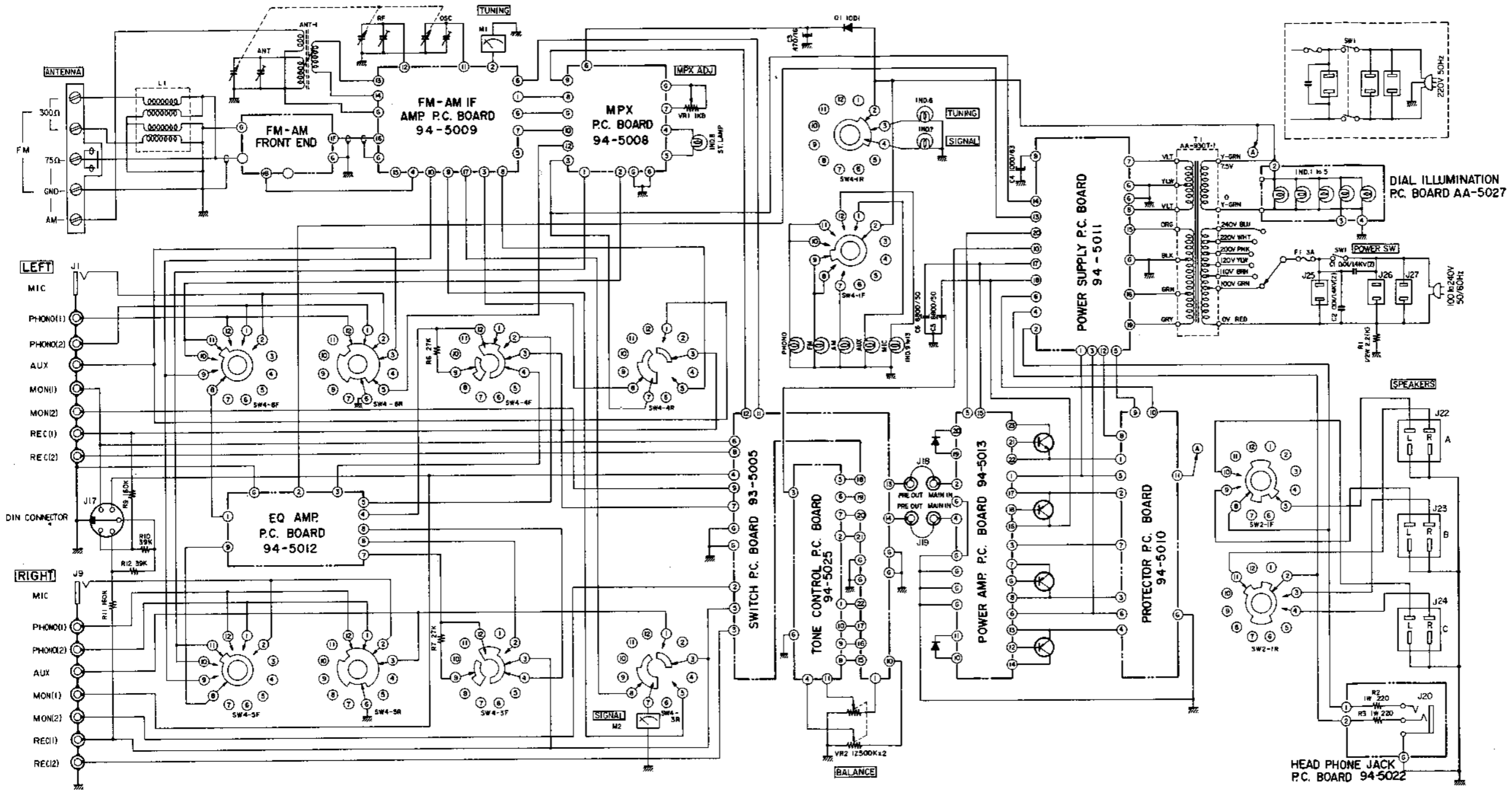

NOTE
UNLESS OTHERWISE SPECIFIED
ALL RESISTORS IN Ω 1/4W (1)
ALL CAPACITORS IN μF 50WV (1)
POWER SWITCH AND SOCKET ARE DIFFERENT
ACCORDING TO AREA.

AA-930
SCHEMATIC DIAGRAM
1462213A

AA-920

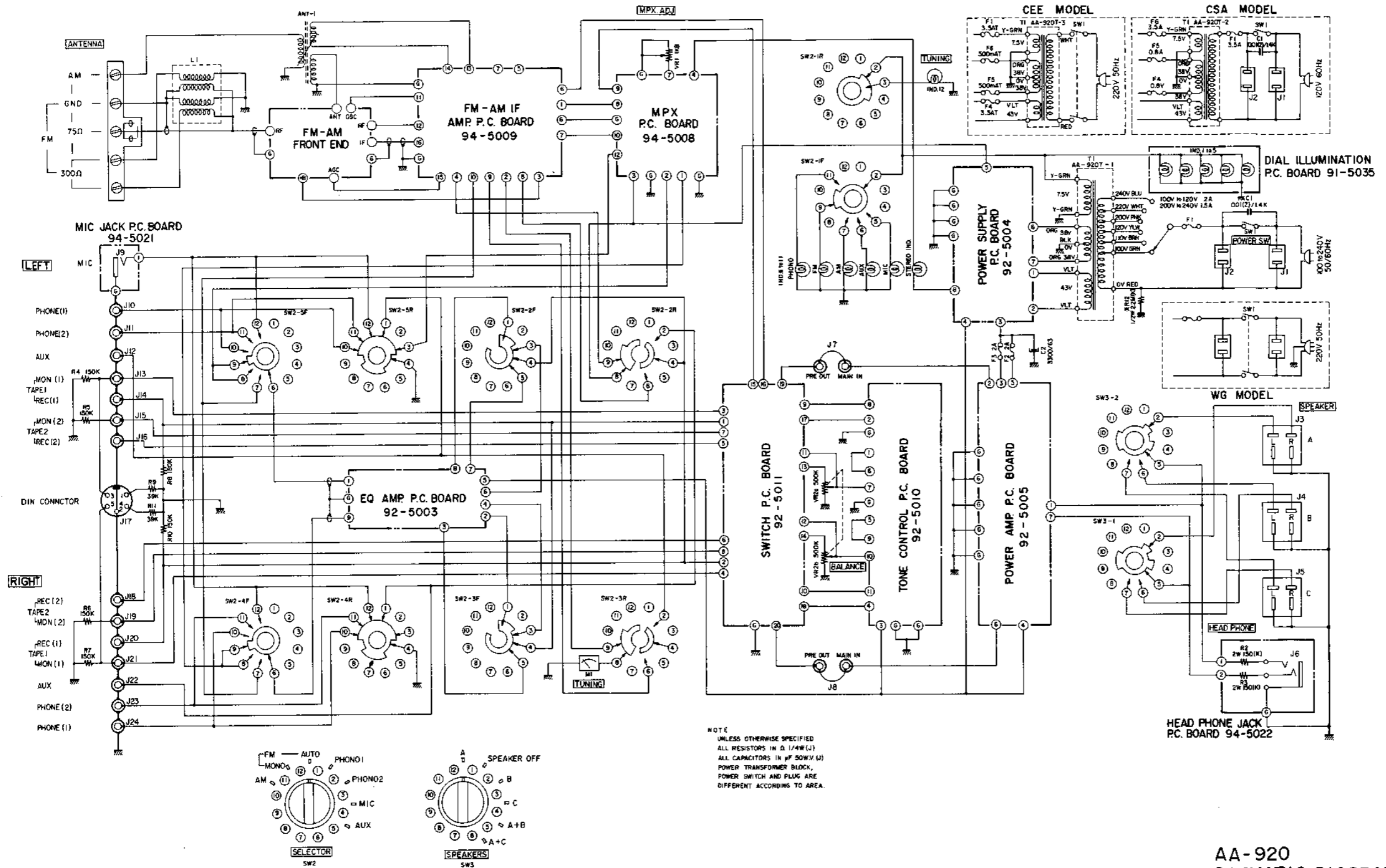

AA-920
SCHEMATIC DIAGRAM
1462214A