

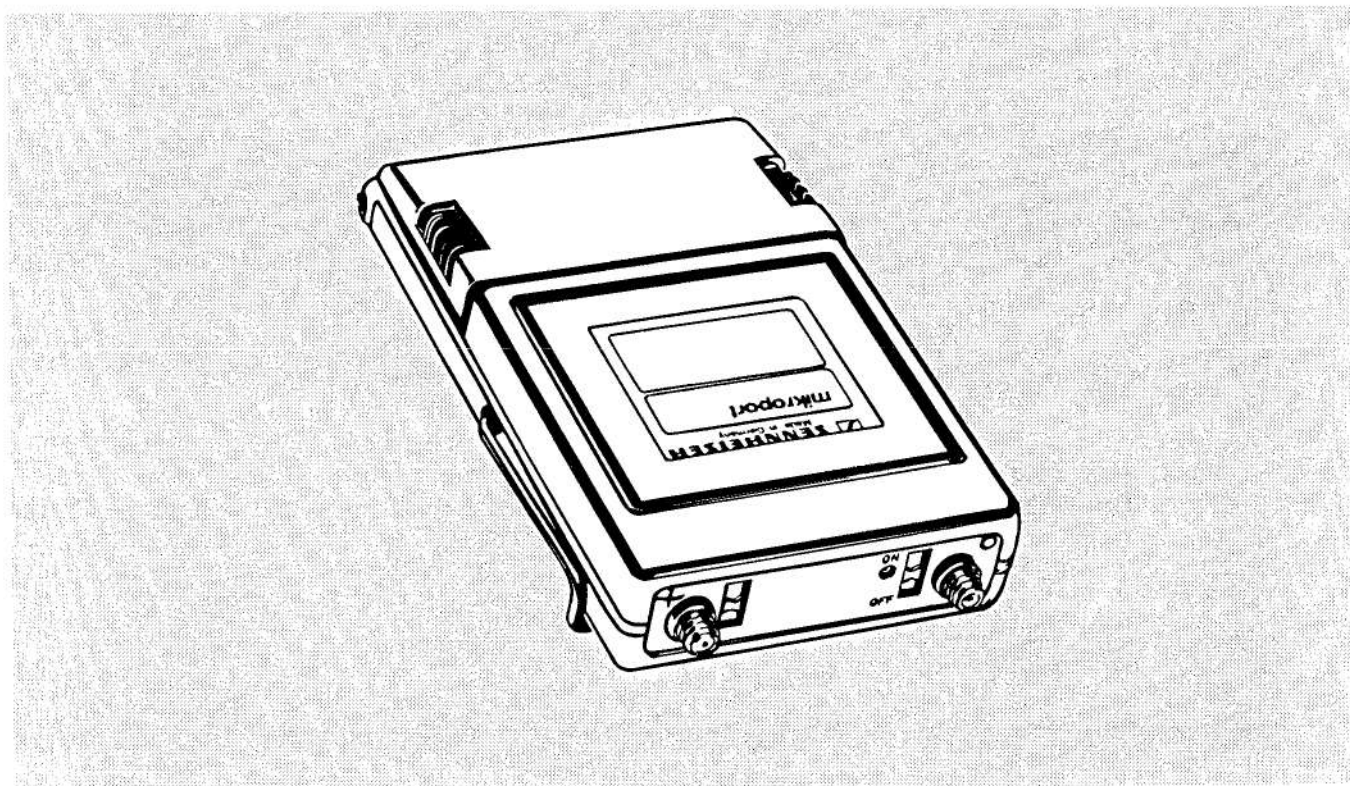

EK 2014 TV



Kurzbeschreibung

Der EK 2014 TV ist ein einkanaliger, auf 2 Frequenzen umschaltbarer Mikroport-Empfänger. In Verbindung mit einem geeigneten Mikroport-Sender, z. B. SK 2012 TV oder SKM 4031 TV läßt sich mit diesem Empfänger eine drahtlose Tonübertragungsstrecke aufbauen, die sich durch hervorragende Funktionssicherheit und hohe Übertragungsqualität auszeichnet. Durch die sehr flache Bauform, die kleinen Abmessungen und das geringe Gewicht ist dieser Mini-Empfänger hervorragend geeignet für Filmteams und elektronische Berichterstattung.

Merkmale:

- Sehr klein und leicht
- Breitband FM
- Robustes Ganzmetallgehäuse
- Umschaltbar auf zwei Empfangsfrequenzen in den Bereichen 450 bis 960MHz
- »HiDyn«-Kompaner
- NF - Ausgangsspannung einstellbar
- Elektronische Rauschsperr, einstellbar
- Einfache und sichere Befestigung durch Clip
- Stromversorgung aus 3 x 1,5V Alkali-Mangan-Batterien, IEC LR 03, Typ »Micro«
- Betriebszeit bis zu 5 Stunden

Brief description

The EK 2014 TV is a single-channel Mikroport receiver which can be set to receive either of two frequencies. When combined with a suitable Mikroport transmitter such as the SK 2012 TV or the SKM 4031 TV it forms a cordless audio transmission circuit distinguished by superior dependability and excellent reproduction quality. Its very low profile, compact dimensions and light weight predestine this miniature receiver for use by film teams and in electronic reporting.

Features:

- Very small and light
- Wide-band FM
- Robust, all-metal housing
- Switchable to one of two frequencies in the 450 to 960 MHz range
- »HiDyn« compander
- Adjustable AF output voltage
- Electronic squelch, adjustable
- Simple, sure clip attachment
- Power supplied by three 1.5 V AlMn batteries, type IEC LR 03, »Micro«
- Battery life up to 5 hours

Inhaltsverzeichnis/Contents

Seite/Page

1.	Bedienungselemente Operating elements	3
2.	Technische Daten Technical Data	4
3.	Schaltungsbeschreibung Circuit description	5
4.	Blockschaltbild Block diagram	7
5.	Service Hinweise Service hints	7
6.	Erforderliche Meßgeräte und Prüfmittel Measuring instruments and test equipment	8
7.	Meßaufbau Test set-up	8
8.	Prüf- und Abgleichanweisung Test and alignment instructions	9
9.	Stromlaufplan Circuit diagram	11
10.	Gedruckte Schaltung Printed circuit board	13
11.	Explosionszeichnung Exploded view	15
12.	Ersatzteile / Schalteile Spare parts / Electronic components	16

1. Bedienungselemente Operating elements

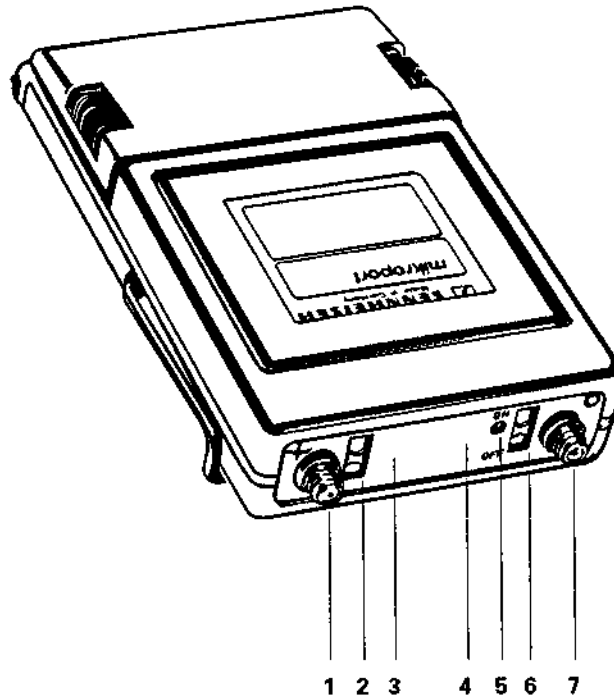

Bedienungselemente

- 1 Antenneneingang
- 2 Kanalschaltung
- 3 Einsteller für Rauschsperrung (unter Abdeckplatte)
- 4 Einsteller für NF - Ausgangspegel (unter Abdeckplatte)
- 5 Betriebsanzeige
- 6 Ein / Aus - Schalter
- 7 NF - Ausgang

Operating elements

- 1 Antenna input
- 2 Channel selector
- 3 Squelch control (under plate)
- 4 AF output control (under plate)
- 5 Operation indicator
- 6 On / Off switch
- 7 AF output

2. Technische Daten

Frequenzbereich	2 Frequenzen im Bereich 450 - 960 MHz
Schaltbandbreite	ca. 3 MHz
Rauschunterdrückungssystem	HiDyn (nicht abschaltbar)
Nennhub/Spitzenhub	± 40 kHz / ± 56 kHz
Geräuschspannungsabstand bei ...	
1,5 µV HF-Eingangsspannung (Nennhub)	≥ 55 dB (DIN 45500, Kurve A)
	≥ 43 dB (CCIR 468, Spitze)
15 µV HF-Eingangsspannung (Nennhub)	≥ 97 dB (DIN 45500, Kurve A)
	≥ 85 dB (CCIR 468, Spitze)
≥ 50 µV HF-Eingangsspannung (Spitzenhub)	≥ 111 dB (DIN 45500, Kurve A)
	≥ 98 dB (CCIR 468, Spitze)
	≥ 65 dB
Nachbarkanalselektion in ±400 kHz Abstand	
Intermodulationsdämpfung bezogen auf 52 dB S/N,	
Trägerabstand 400 kHz und 800 kHz (2 Sender-Methode)	≥ 63 dB
ZF Selektionsabstand	≥ 100 dB
Spiegelselektion	≥ 60 dB
HF-Eingänge	λ/4 - Strahler, abschraubbar
NF-Ausgang (unsymmetrisch)	Innenwiderstand 10 Ω, Nennlast 500 Ω
NF-Ausgangsspannung bei ≥ 1 µV HF-Eingangsspannung bezogen auf Spitzenhub	einstellbar von 20 mV - 1,8 V (-2 dB), eingestellt auf +1,6 dBm
Tonfrequenzbereich -3 dB, Deemphasis 50 µsec.	50 Hz - 20 kHz
Klirrfaktor bei Nennhub, 1 kHz und 100 µV HF-Spannung	≤ 1 %
Rauschsperr, einstellbar	0 - ca. 100 µV, eingestellt auf 1 µV
Stromversorgung	3 Stck. 1,5 V - Batterien, Alkali - Mangan Type IEC LR03 "Micro"
Stromaufnahme	≤ 85 mA bei 4,5 V
Betriebszeit	ca. 5 Stunden
Abmessungen in mm	92 x 52 x 17
Gewicht einschließlich Batterien	ca. 190 g
DBP - Prüfnummer	A 013 450B RF

Änderungen vorbehalten

2. Technical data

Frequency response	2 frequencies between 450 and 960 MHz
Switching bandwidth	approx. 3 MHz
Noise reduction system	HiDyn (not switchable)
Rated/peak swing	± 40 kHz / ± 56 kHz
Signal-to-noise ratio at ...	
1.5 µV RF input (nominal swing)	≥ 55 dB (DIN 45500, curve A)
	≥ 43 dB (CCIR 468, peak)
15 µV RF input (nominal swing)	≥ 97 dB (DIN 45500, curve A)
	≥ 85 dB (CCIR 468, peak)
≥ 50 µV RF input (peak swing)	≥ 111 dB (DIN 45500, curve A)
	≥ 98 dB (CCIR 468, peak)
	≥ 65 dB
Adjacent channel rejection when mistuned by 400 kHz	
Intermodulation attenuation S/N = 52 dB, carrier spacing	
400 kHz and 800 kHz (2 transmitter method)	≥ 63 dB
IF selectivity	≥ 100 dB
Image rejection	≥ 60 dB
RF inputs	λ/4 - wave radiator
AF output (unbalanced)	internal resistance 10 ohms; nominal load: 500 ohms
AF output voltage at peak deviation, more than 1 µV RF voltage	adjustable 20 mV - 1.8 V (-2 dB), adjusted to +1.6 dBm
Audio frequency range	50 - 20 000 Hz
THD at rated swing, 1 kHz and 100 µV RF voltage	≤ 1%
Squelch, adjustable	0 - approx. 100 µV, adjusted to 1 µV
Power supply	3 pcs. 1.5V batteries, alkaline manganese type IEC LR03 "Micro"
Current consumption	≤ 85 mA at 4.5 V
Operating time	approx. 5 hours
Dimensions in mm	92 x 52 x 17
Weight including batteries	approx. 190 g

Subject to alterations.

3. Schaltungsbeschreibung

Der Mikroport-Taschenempfänger EK 2014 TV ist ein tragbarer Empfänger für drahtlose Mikrofone. Er arbeitet im UHF-Bereich auf den Frequenzen 450 - 960 MHz.

3.1. HF - Vorverstärker

Das HF-Signal gelangt über den 50 Ohm-Eingang P1 auf das Eingangsbandfilter F1. Diesem schließt sich die HF-Vorstufe Q1 an. Diese Stufe ist mit einem GAS-Feldeffekttransistor bestückt. Die verstärkte Antennenspannung wird über das Bandfilter F2 dem 1. Mischer Q2 zugeführt.

3.2. 1. Mischer, 1. Oszillator, Vervielfacher

Auch hier wird ein DoppelGate GAS-Feldeffekttransistor eingesetzt, dem über Gate 2 die Oszillatorspannung zum Mischen zugeführt wird. Um eine hohe Frequenzstabilität zu erreichen, wird die Oszillator - Mischspannung aufwendig erzeugt. Da der Empfänger zwei Festfrequenzen hat, ist der Oszillator Q6 mit zwei Schwingquarzen bestückt. Er arbeitet im Frequenzbereich 160 - 240 MHz. Auch diese Oszillatorstufe arbeitet mit einem Doppel-Gate GAS-Feldeffekttransistor. Dem Oszillator folgt der Vervielfacher Q7. Er arbeitet von Kanal 18 bis 30 (450 - 550 MHz) als Verdoppler, von Kanal 31 bis 60 (550 - 790 MHz) als Verdreifacher und von Kanal 61 bis 82 (790 - 960 MHz) als Vervierfacher der Oszillatorfrequenz. Das Bandfilter F3 sorgt für ein sauberes Oszillatormischsignal, um Nebenempfangsstellen zu vermeiden. Die Mischfrequenz liegt um den Betrag der ersten Zwischenfrequenz unter der Empfangsfrequenz und mischt diese im ersten Mischer Q2 auf 74 MHz herunter. Über das ZF-Filter L9 gelangt die Zwischenfrequenz auf den ersten ZF-Verstärker Q3, der zur Erzielung guter Intermodulationseigenschaften in Gate - Schaltung arbeitet und mit einem Feleffekttransistor bestückt ist.

3.3. 2. Mischer, 2. Oszillator

Die verstärkte Spannung wird über das Filter L10 auf den zweiten Mischer U1 gegeben. Der integrierte Mischer ist ein doppelt balancierter single Gate-GASFET-Mischer. Er wird über den Balluntrafo TR1 symmetrisch angesteuert. Das Mischsignal wird im zweiten Oszillator Q4 mit einem NPN-Siliziumtransistor erzeugt. Der Oszillator ist quartzgesteuert und schwingt auf 63,3 MHz. Die Mischspannung gelangt über den Balluntrafo TR2 symmetrisch auf den Mischer U1. Der Siliziumtransistor Q5 stabilisiert den Arbeitspunkt des Mixers, der bei dem eingestellten Arbeitspunkt einen Intermodulationsabstand von 80 dB liefert. Der Mischer arbeitet auf das symmetrische Filter L13, das auf die zweite Zwischenfrequenz von 10,7 MHz abgestimmt ist.

3.4. 2. ZF - Verstärker, Demodulator

Über das keramische ZF-Filter YF1 steht die HF-Spannung zur weiteren Verstärkung dem Begrenzerverstärker und FM-Demodulator U2 zur Verfügung. In den Begrenzerverstärker ist ein zweites keramisches ZF-Filter YF2 zur Erzielung guter Nachbarkanalselektion eingeschleift. Der Demodulator arbeitet als Quadratur-Demodulator. Am Ausgang steht am Deemphasisglied R37 und C47 (50 µsec) das NF-Signal zur Verfügung. Mit Hilfe des zweiten NF-Ausgangs des ZF-Verstärkers läßt sich durch Umbestückung R38 anstelle von R37 die NF-Phasenlage bei Bedarf um 180 Grad drehen. Da der NF-Ausgang des ZF-Verstärkers 60 kOhm Innenwiderstand hat, folgt ein Impedanzwandler und NF-Vorverstärker vor dem HiDyn-Expander.

3.5. Expander, NF - Endstufe

Benutzt wird hierfür eine Hälfte der integrierten Schaltung U4. Die NF-Endstufe U5, Q9 und Q10 macht eine Verstärkung von 1 und den NF-Ausgang brauchbar für niederohmige Hörer. Die

3. Circuit description

The EK 2014 TV Mikroport body-pack receiver is a portable UHF receiver for wireless microphones. It operates in a frequency range of 450 to 960 MHz.

3.1. RF preamplifier

The RF signal is routed via P1 (50 Ohm) to the bandpass filter F1. The bandpass filter connects to the RF input section Q1 which incorporates a GAS FET. The amplified antenna voltage is routed via the bandpass filter F2 to the 1st mixer Q2.

3.2. 1st mixer, 1st oscillator, multiplier

The oscillator voltage is passed via gate 2 to the dual gate GAS FET. A complicated circuit for generating the oscillator mixing voltage ensures high frequency stability. Oscillator Q6 is equipped with two crystals as the receiver features two standard frequencies. It operates in a frequency range of 160 to 240 MHz. This oscillator stage also incorporates a dual gate GAS FET. The oscillator is connected to the multiplier Q7. It doubles the oscillator frequency in channels 18 to 30 (450 - 550 MHz), triples it in channels 31 to 60 (550 - 790 MHz) and quadruples it in channels 61 to 82 (790 - 960 MHz). The bandpass filter F3 supplies a clear oscillator mixing signal, thus preventing interference. The mixing frequency equals the receiver frequency minus the 1st IF. Entering the 1st mixer Q2 it is reduced to 74 MHz. The 1st IF is routed via the IF filter L9 to the 1st IF amplifier Q3. Q3 is a FET connected as a gate circuit in order to achieve good intermodulation properties.

3.3. 2nd mixer, 2nd oscillator

The amplified voltage is fed into the 2nd mixer U1 via filter L10. The integrated mixer is a double balanced single gate GAS FET mixer. It is balanced by the balanced-to-unbalanced transformer TR1. The mixed signal is generated in the 2nd oscillator Q4 by an NPN silicon transistor. The oscillator is crystal-controlled and oscillates at 63.3 MHz. The mixed voltage is routed via the balanced-to-unbalanced transformer TR2 to the mixer U1. The silicon transistor Q5 stabilizes the operating point of the mixer which delivers an intermodulation distance of 80 dB at the operating point selected. The mixer is connected to the balanced filter L13 which is tuned to the 2nd IF of 10.7 MHz.

3.4. 2nd IF amplifier, demodulator

The RF voltage is routed via the ceramic filter YF1 to the limiting amplifier and the FM demodulator for further amplification. The limiting amplifier comprises a 2nd ceramic IF filter to achieve good rejection of adjacent channels. The demodulator is a quadrature demodulator. The audio signal is available at the output of deemphasis components R37 and C47 (50 µs). The audio phase can be shifted by 180° with the help of the second audio output of the IF amplifier by using R38 instead of R37, if need be. As the audio output of the IF amplifier has an internal resistance of 60 kOhm it is connected to an impedance transformer and an audio amplifier before connecting to the HiDyn expander.

3.5. Expander, audio output stage

One half of the integrated circuit U4 forms the expander and the audio output stage. The amplification factor of the audio output stage U5, Q9 and Q10 is 1, thus making the audio output

maximale Ausgangsspannung des Empfängers beträgt 1,8 V bei 56 kHz Spitzenhub. Mit dem Einsteller R59 läßt sich der Ausgangspegel stufenlos bis zu 10 mV bei Nennhub herunterstellen. Um keinen Störabstand zu verlieren, wurde der Einsteller hinter dem NF-Verstärker angeordnet. Der Einstellwiderstand R41 vor dem NF-Vorverstärker dient zum Einpegeln der maximalen Ausgangsspannung bei 56 kHz Spitzenhub. Der Feldeffekttransistor Q8 dient als Schalter für die Rauschsperrschaltung.

3.6. Squelch - Komparator

Der ZF-Verstärker U2 liefert am Regelspannungsausgang eine Gleichspannung, die der HF-Eingangsspannung proportional ist. Diese Spannung steuert einen Differenzverstärker im IC U4, dem über den Einstellwiderstand R49 eine Schaltschwelle von 0 bis 100 μ V vorgegeben werden kann. Der Ausgang des Differenzverstärkers steuert den Schalttransistor Q8, der bei Unterschreiten der eingestellten Rauschsperrschwelle hochohmig wird und den Signalweg sperrt. Am NF-Ausgang wird das verrauschte Signal abgeschaltet. Die Bauteile D3, R46 und C55 bewirken eine Ansprechverzögerung beim Durchschalten des NF-Signals. Hierdurch werden Einschaltgeräusche des drahtlosen Mikrofonsenders unterdrückt.

3.7. DC / DC - Wandler

Die Stromversorgung des Empfängers geschieht aus drei Batterien der Type IEC LR03 „Micro“. Der Empfänger kann bei Bedarf auch über die Antennenbuchse P1 aus einer externen 4,5 V-Quelle gespeist werden. Für diesen Fall muß L2 bestückt werden. Da eine Betriebsspannung von 4,5 V für einen hochwertigen Empfänger zu gering ist, wird diese mit einem Gleichspannungswandler auf 7,4 V heraufgesetzt. Die Transistoren Q1 - Q3 erzeugen die Referenzspannung für den Sperrwandler Q4, Q5 und T1. Die Wandlerfrequenz liegt bei 50 kHz. Der Kondensator C3 verhindert den Oberwellenanteil im 10 MHz-Bereich. Die Diode D1.1 richtet die Wandlerspannung gleich, und am Ladekondensator C66 steht die stabilisierte Betriebsspannung des Empfängers zur Verfügung. Als Referenz für die Ausgangsspannung dient die Zehnerdiode D2.

3.8. Betriebsanzeige

Die Leuchtdiode D5 ist die Betriebsanzeige des Empfängers. Sie wird direkt aus der Batterie gespeist. Die Batteriewächterschaltung dient zur Überwachung der Empfänger-Batteriespannung. Die integrierte Schaltung U1.1 schaltet bei einer Batteriespannung von 2,8 V die Kippstufe U1.2 ein, die im Sekundenrhythmus die Diode D4.2 auf Masse schaltet. Die Diodenstrecke wird parallel zum Arbeitswiderstand der Leuchtdiode geschaltet und schließt diesen kurz, was zur Folge hat, daß die LED im Sekundenrhythmus blinkt. Ausgehend vom Blinkensatz der Leuchtdiode, beträgt die Betriebszeit mit dem Batteriesatz noch ca. 30 Minuten.

suitable for low impedance headphones. The maximum output voltage of the receiver amounts to 1.8 V at a peak deviation of 56 kHz. The potentiometer R59 allows the output level to be progressively adjusted to 10 mV at nominal deviation. In order not to deteriorate rejection of adjacent channels the audio amplifier precedes potentiometer. Preceding the audio pre-amplifier is trimming potentiometer R41 which serves to adjust maximum output voltage at a peak deviation of 56 kHz. FET Q8 forms the squelch switch.

3.6. Squelch comparator

IF amplifier U2 supplies a DC voltage at the control voltage output which is proportional to the RF input voltage. This voltage controls the differential amplifier in IC U4, the threshold of which can be pre-selected in a range of 0 to 100 μ V using the trimming potentiometer R49. The output of the differential amplifier is connected to the switching transistor Q8 which is of high impedance and blocks the signal path if the preset threshold is not exceeded. The noise signal is switched off at the audio output. When switching through the audio signal the response time is delayed by D3, R46 and C55 in order to prevent noise while switching the wireless microphone transmitter on or off.

3.7. DC / DC converter

Power is supplied to the receiver by three IEC LR03 „Micro“ batteries. The receiver can also be fed by an external 4.5 V source via antenna socket P1, if need be. In this case L2 has to be used. Since an operating voltage of 4.5 V is far too low for a high quality receiver, it is increased to 7.5 V by means of a DC/DC converter. Transistors Q1 - Q3 produce the reference voltage for the blocking oscillator Q4, Q5 and T1. The oscillator frequency is 50 kHz. In the 10 MHz range capacitor C3 prevents generating harmonics. Diode D1.1 rectifies the converter voltage. The stabilized operating voltage of the receiver is available at capacitor C66. Zener diode D2 serves as a reference for the output voltage.

3.8. On/off indicator

LED D5 indicates the operating status of the receiver. It is supplied by a battery. Battery test functions serve to control the receiver battery voltage. At a battery voltage of 2.8 V the integrated circuit U1.1 switches on the multivibrator U1.2 which switches diode D4.2 to ground in minute intervals. The diodes are connected in parallel with the LED operating resistor. Thus the resistor is short-circuited and causes the LED to blink in minute intervals. If the LED starts to blink the remaining operating time still amounts to approx. 30 minutes.

Notizen:

Notes:

4. Blockschaltbild Block diagram

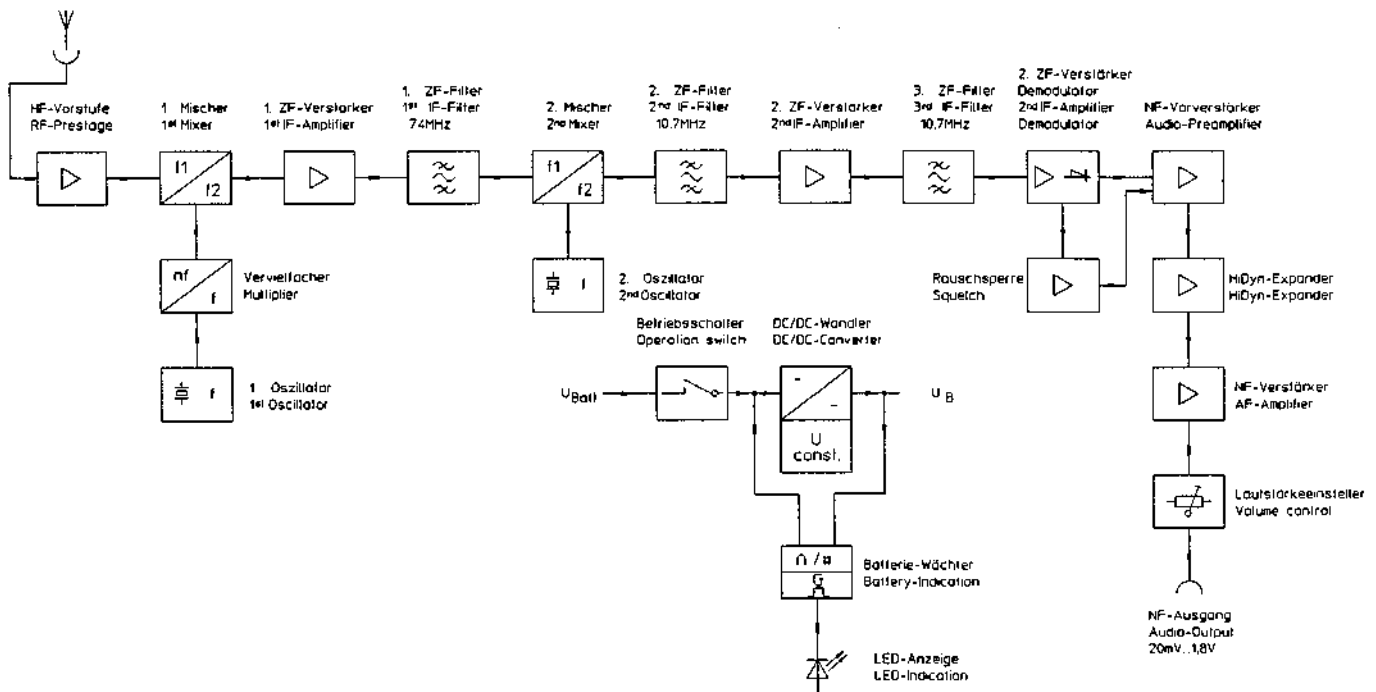

5. Service Hinweise

5.1. Abgleich

Bei einem eventuell notwendigen Nachgleich oder einer Überprüfung der technischen Daten ist es nicht erforderlich, das Gerät vollständig zu demontieren. Alle erforderlichen Abgleich-elemente sind nach Entfernen der Kunststoffabdeckung des Typenschildes von außen zugänglich.

- Batteriefach öffnen, Batterien entnehmen
- Abdeckung (7) und Typenschild (6) durch lösen der Schraube (8) entnehmen. Empfänger ist nun für den Abgleich vorbereitet (siehe Explosionszeichnung Seite 15).

5.2. Demontage

- Siehe 5.1.
- Batterieabdeckung durch lösen der Schrauben (14) entfernen
- Schrauben (12) im Batteriefach lösen, Einsatz (11) entnehmen
- Gummi's (4) von P1 und P2 entfernen
- Leiterplatte durch lösen der Schlitzmutter (5) entnehmen

5.3. Phasenlage des NF-Ausgangs

Die Phasenlage kann um 180° gedreht werden. Hierzu ist R38 anstatt R37 zu bestücken und somit der invertierende Ausgang des Demodulators U2 (Pin7) zu beschalten.

5.4. Quarzberechnung

$$f_Q = \frac{f_{HF} - 74 \text{ MHz (+ 74 MHz für K61 - 71)}}{\text{Vervielfacher Faktor X}}$$

Vervielfacher Faktor 2 = 450 - 550 MHz (Kanal 18 - 30)
 Vervielfacher Faktor 3 = 550 - 790 MHz (Kanal 31 - 60)
 Vervielfacher Faktor 4 = 790 - 960 MHz (Kanal 61 - 82)

Die Eingangsfrequenzen sind innerhalb einer Schaltbandbreite von max. 3 MHz zu wählen.

5. Service hints

5.1. Alignment

It is not necessary to disassemble the entire device in order to change or check technical data. All the components needed for this purpose are freely accessible after removing the plastic cover and the type plate.

- Open the battery compartment and remove the batteries
- Remove the plastic cover (7) and the type plate (6) by loosening screw (8). The receiver is ready for alignment (see exploded view page 15).

5.2. Disassembly

- see 5.1.
- Remove battery compartment's lid by loosening screw (14)
- Loosen screw (12) battery compartment, remove insert (11)
- Remove plastic rings (4) from P1 and P2
- Remove p.c.b. by loosening slotted round nut (5)

5.3. Phase at the audio output

Phases can be shifted by 180°, if need be. For that purpose R38 has to be connected instead of R37, thus using the inverting output of demodulator U2 (pin 7).

5.4. Calculating crystals

$$f_Q = \frac{f_{RF} - 74 \text{ MHz (+ 74 MHz for channels 61 to 71)}}{\text{multiplication factor X}}$$

Multiplication factor 2 = 450 - 550 MHz (channel 18 - 30)
 Multiplication factor 3 = 550 - 790 MHz (channel 31 - 60)
 Multiplication factor 4 = 790 - 960 MHz (channel 61 - 82)

Input frequencies are to be selected within a switching bandwidth of max. 3 MHz.

6. Erforderliche Meßgeräte und Prüfmittel

- 1 40 dB-Kabel (siehe Meßaufbau)
- 1 Spektrum-Analysator (z. B. Advantest R 4131A)
- 1 Tracking Generator (z. B. Advantest TR 4131A)
- 1 Klirrfaktormesser (z. B. UPM 550-1)
- 1 Fremdspannungsfilter (z. B. UPM 550-1)
- 1 NF-Millivoltmeter (z. B. UPM 550-1)
- 1 Oszilloskop (z. B. Hameg HM 605)
- 1 Meßsender (z. B. Rohde & Schwarz SMS 2)
- 1 Vielfachmeßinstrument (100 k Ω /V)
- 1 Netzgerät 0 - 10 V
- 2 HF-Meßadapter (Sennheiser Ident-Nr. 29058)

6. Measuring instruments and test equipment

- 1 40 dB cable (see test set-up)
- 1 Spectrum analyzer (e. g. Advantest R 4131A)
- 1 Tracking generator (e. g. Advantest TR 4131A)
- 1 THD measuring device (e. g. UPM 550-1)
- 1 Unweighted noise filter (e. g. UPM 550-1)
- 1 AF millivoltmeter (e. g. UPM 550-1)
- 1 Oscilloscope (e. g. Hameg HM 605)
- 1 Test generator (e. g. Rohde & Schwarz SMS 2)
- 1 Multimeter (100 k Ω /V)
- 1 Power supply 0 to 10 V
- 2 RF-measuring adapter (Sennheiser Ident-Nr. 29058)

7. Meßaufbau/Test set-up

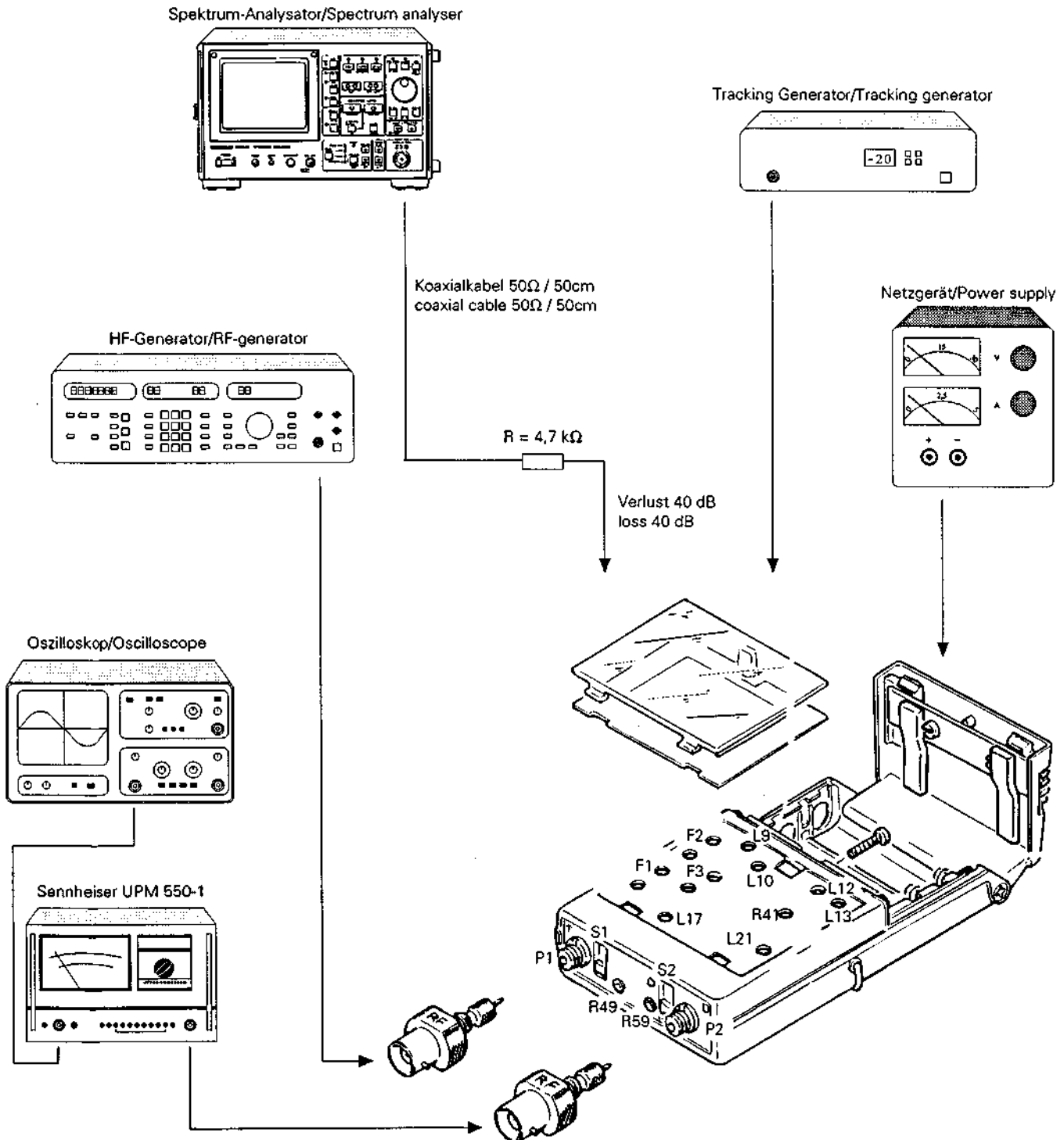

8. Prüf - und Abgleichanweisung

Nr.	Messung, Einstellung	Signal-einspeisung	Vorbereitung, Geräteeinstellung	Meßpunkt	Sollwert	Einsteller	Bemerkungen
1	DC / DC - Wandler Ausgang	Netzgerät = 4,5 V	S2 'Ein' R59-Rechtsanschlag R49-Linksanschlag	TP 5	7,4 V ± 0,2 V		
1.1	Stromaufnahme, minimal	wie 1.		Einspeisung	≤ 85 mA		
1.2	Batteriewächter	Netzgerät = 2,8 V				R9	D5 (LED) beginnt zu blinken
1.3	Stromaufnahme, maximal	wie 1.2.		Einspeisung	ca. 130 mA		
2	1. Oszillator	Netzgerät = 4,5 V	Spektrum-Analysator	TP 14		L17	Einschwingverhalten durch Ein - und Aus - schalten überprüfen
2.1	1. Oszillator (Pegel)	wie 2.	Spektrum-Analysator	TP 14	max. Pegel ≥ +3 dBm	C73, C74	
3	2. Oszillator	wie 2.	Spektrum-Analysator	C17 / C18	63,3 MHz max. Pegel ≥ 0 dBm	L12	Einschwingverhalten durch Ein - und Aus - schalten überprüfen
4	HF - Vorverstärker	wie 2. Tracking Generator an P1	Spektrum-Analysator	TP 15	max. Bandbreite ca. 30 MHz	C69, C70, C71, C72	Mitte Durchlaufkurve zwischen Empfangsfrequenzen Kanal 1 und Kanal 2
5	Quadratur - Demodulator	HF-Eingangsfrequenz U=10 µV Hub=40 kHz NF=1 kHz an P1	UPM 550-1, Oszilloskop	P2 NF-Ausgang	max. Pegel	L21	
6	NF - Ausgang	wie 5. Hub=56 kHz	UPM 550-1, Oszilloskop	P2	1,6 Veff	R41	NF-Ausgangspegel soll nicht in Begrenzung gehen
EK 2014 TV Leiterplatte und Batteriefach in Gehäuse einsetzen, NF-Ausgang P2 überprüfen und eventuell optimieren (Nr.2...6)							
7	Rauschsperr	wie 5. U=0...100 µV	R49 (Squelch) regeln				NF - Signal abhören
8	Klirrfaktor	wie 5. U=100 µV	UPM 550-1, Oszilloskop R49-Linksanschlag	P2	≤ 1 %	L21	NF-Ausgangspegel (max.) überprüfen
9	Fremdspannungsabstand	wie 5. U=1,5 µV	UPM 550-1, Oszilloskop	P2	≥ 55 dB(A)	C73, C74 L12, C69, C70, C71, C72, L21	
9.1	Fremdspannungsabstand	wie 5. U=15 µV	UPM 550-1, Oszilloskop	P2	≥ 97 dB(A)	wie 9.	

8. Test and alignment instructions

No.	Adjustment/ Measurement	Signal input	Preparations/ Settings	Test point	Nominal value	Adjusting device	Remarks
1	DC/DC converter output	Power supply 4.5 V	S2 "ON" R59-cw R49-ccw	TP 5	7.4 V ± 0.2 V		
1.1	Min. current consumption	as 1		Power supply	≤ 85 mA		
1.2	Batterie indication	Power supply 2.8 V				R9	D5 (LED) starts to blink
1.3	Max. current consumption	as 1.2		Power supply	approx. 130 mA		
2	1. Oscillator	Power supply 4.5 V	Spectrum analyser	TP 14		L17	Check transient response by actuating ON/OFF switch
2.1	1. Oscillator (level)	as 2	Spectrum analyser	TP 14	max. level ≥ +3 dBm	C73, C74	
3	2. Oscillator	as 2	Spectrum analyser	C17 / C18	63.3 MHz max. level ≥ 0 dBm	L12	Check transient response by actuating ON/OFF switch
4	RF pre - amplifier	as 2, Tracking generator to P1	Spectrum analyser	TP 15	max. bandwidth 30 MHz	C69, C70, C71, C72	Mid-transmission band between receiver frequencies channel 1 and channel 2
5	Quadrature demodulator	RF=Input frequency U=10 μV Dev=40 kHz AF=1 kHz to P1	UPM 550-1, Oscilloscope	P2 AF output	max. level	L21	
6	AF output	as 5, Dev=56 kHz	UPM 550-1, Oscilloscope	P2	1.6 Veff	R41	RF output level must not exceed limiting value
Put printed circuit board and battery contacts into EK 2014 TV housing, optimize the audio signal (P2) by repeating steps 2...6							
7	Squelch	as 5, U=0...100 μV	Turn R49 (Squelch)				Monitor audio signal
8	THD	as 5, U=100 μV	UPM 550-1, Oscilloscope R49-ccw	P2	≤ 1. %	L21	Check output level at P2
9	S / N ratio	as 5, U=1.5 μV	UPM 550-1, Oscilloscope	P2	≥ 55 dB(A)	C73, C74 L12, C69, C70, C71, C72, L21	
9.1	S / N ratio	as 5, U=15 μV	UPM 550-1, Oscilloscope	P2	≥ 97 dB(A)	as 9	

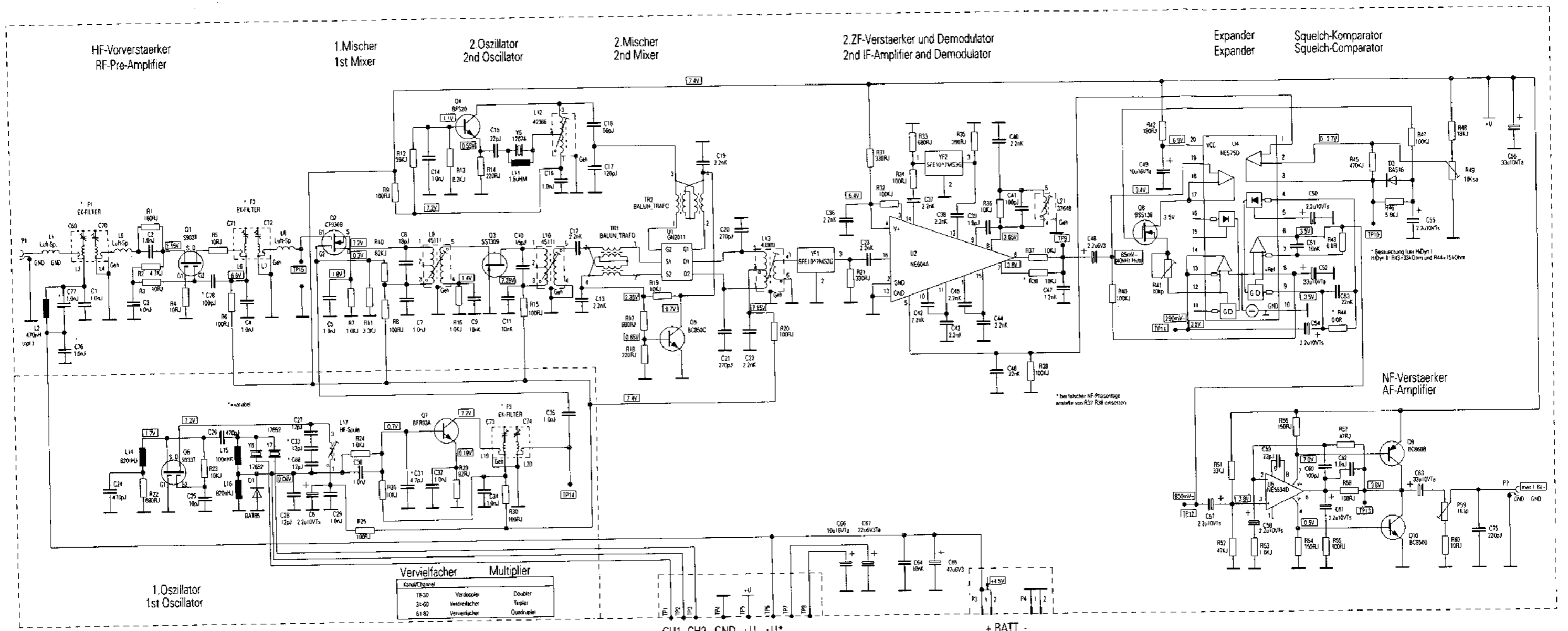

□ Meß- und Testpunkte
Measuring and test points

Gedruckte Schaltung EK 2014 TV, Bestückungsseite, Layer 1
Printed circuit board EK 2014 TV, equipped side, layer 1

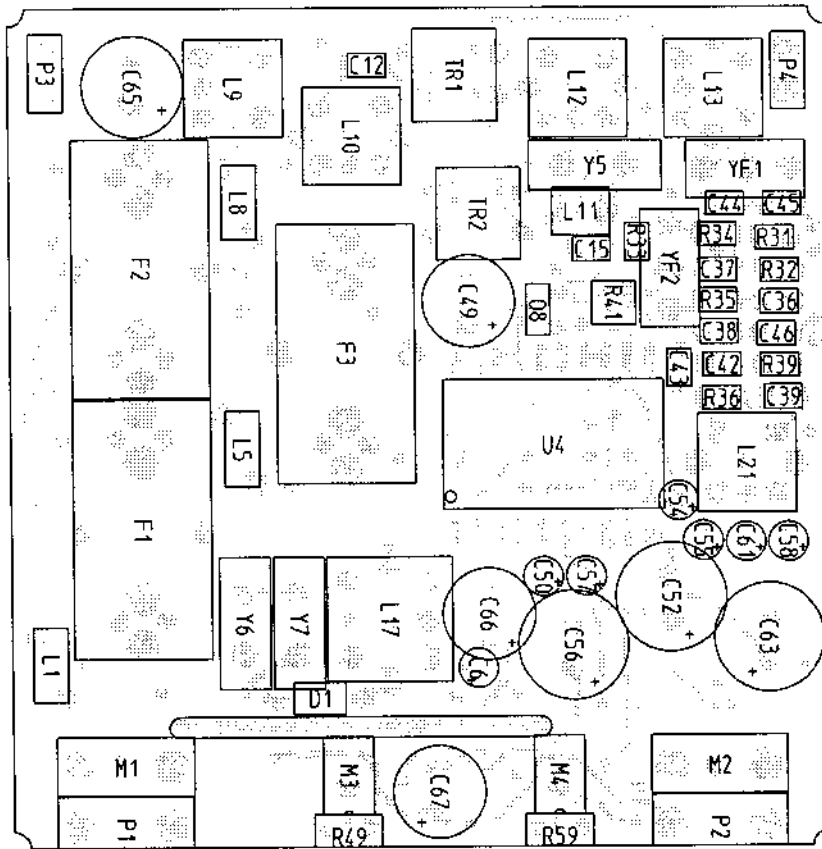

Gedruckte Schaltung EK 2014 TV, Bestückungsseite, Layer 2
Printed circuit board EK 2014 TV, equipped side, layer 2

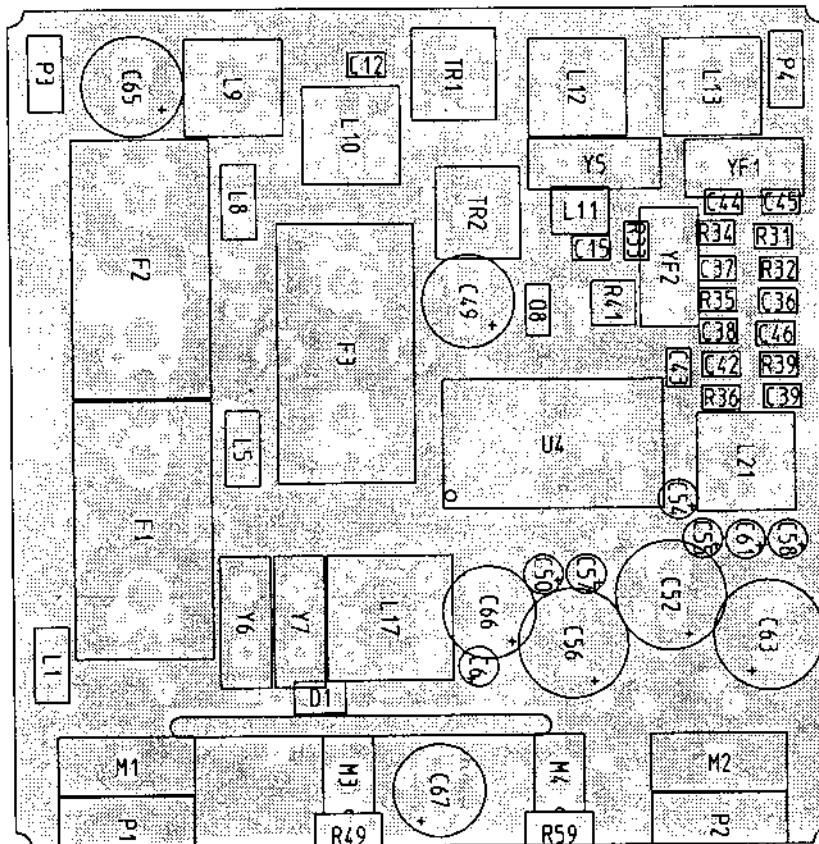

Gedruckte Schaltung EK 2014 TV, Bestückungsseite, Layer 3
Printed circuit board EK 2014 TV, equipped side, layer 3

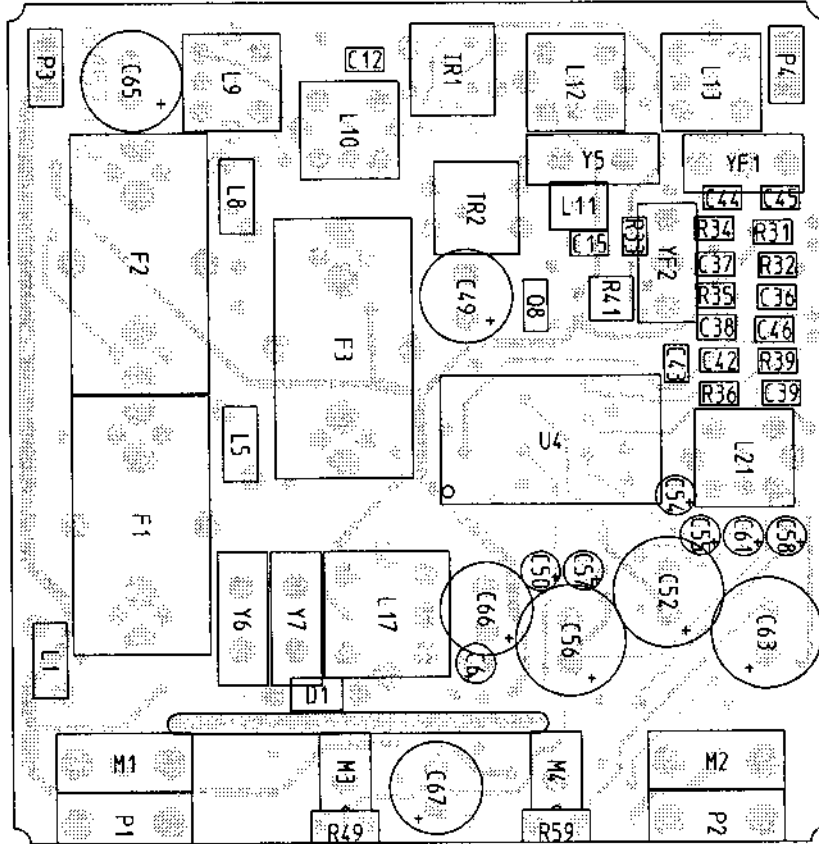

Gedruckte Schaltung EK 2014 TV, Lötseite
Printed circuit board EK 2014 TV, solder side

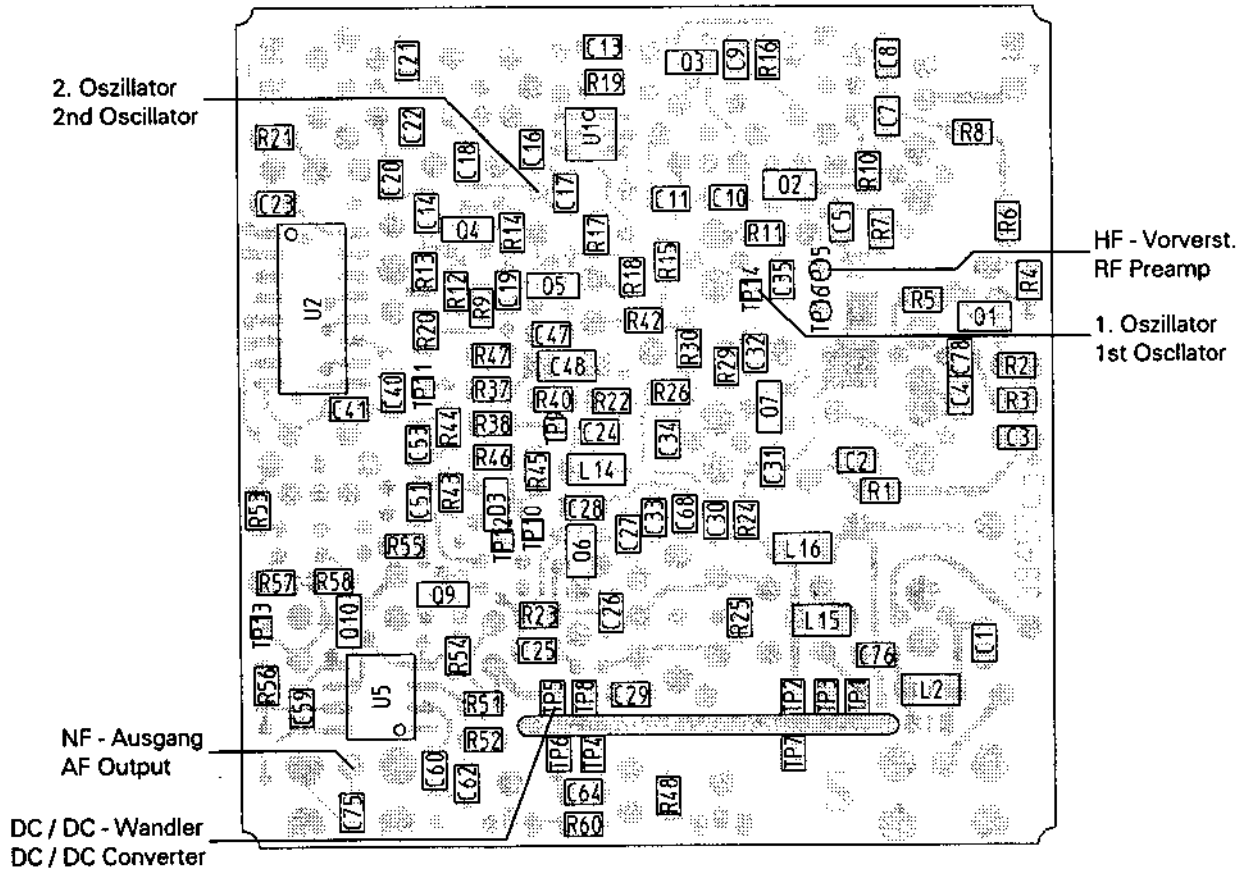

Stromlaufplan EK 2014 TV, DC/DC-Wandler
Circuit diagram EK 2014 TV, DC/DC converter

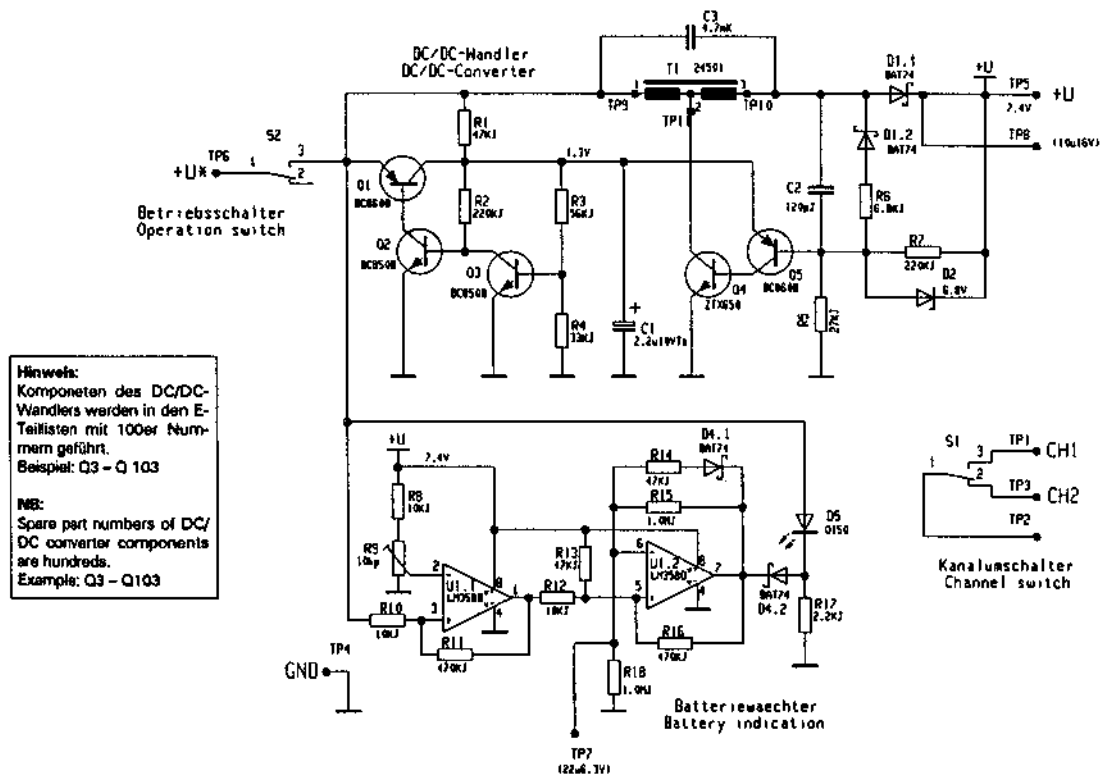

Gedruckte Schaltung EK 2014 TV, DC/DC-Wandler, Bestückungsseite
Printed circuit board EK 2014 TV, DC/DC converter, equipped side

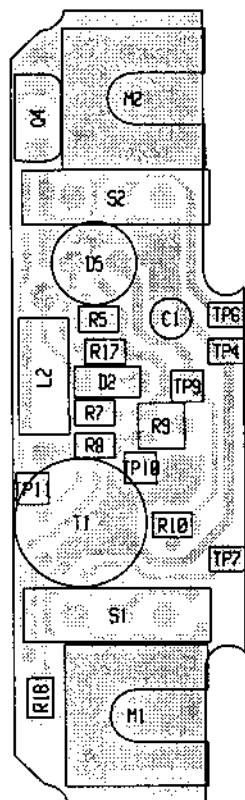

Gedruckte Schaltung EK 2014 TV, DC/DC-Wandler, Lötseite
Printed circuit board EK 2014 TV, DC/DC converter, solder side

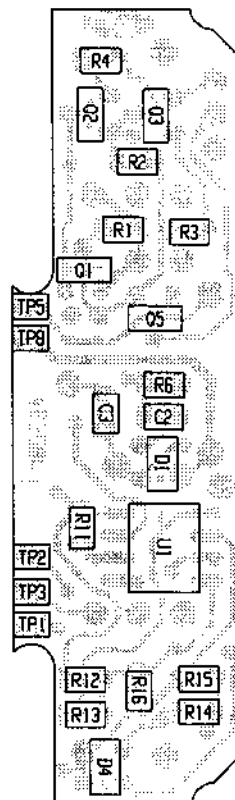

11. Explosionszeichnung
Exploded view

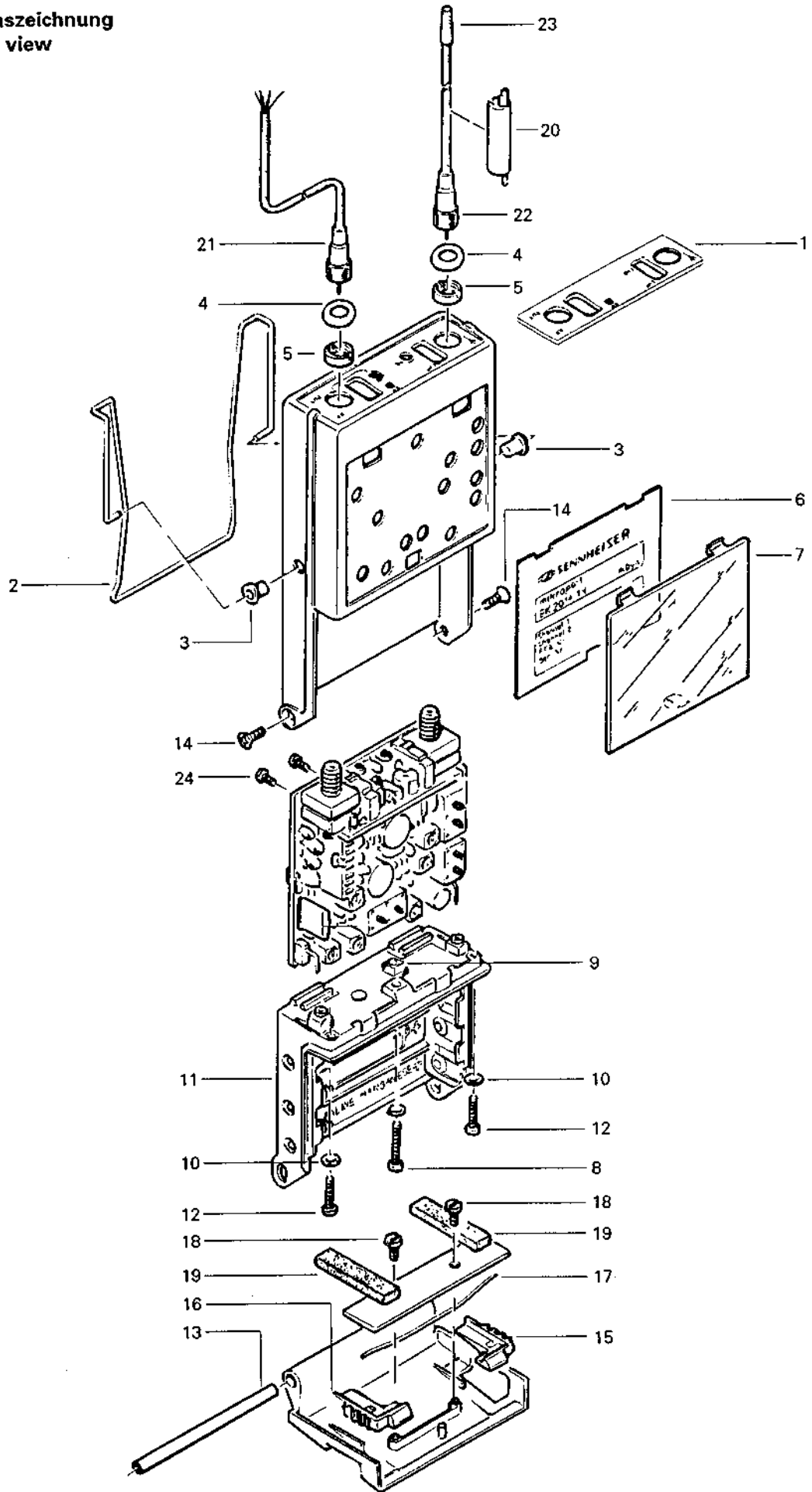

Pos. Nr. Pos. No.	Bezeichnung Description	Bestell- Nr. Part No.
	EK 2014 TV, 450 - 702 MHz	
001	Frontblech Front panel	34333
002	Klammer Clip	15851
003	Buchse für Klammer Socket for clip	26508
004	O-Ring	44878
005	Schlitzmutter Slotted nut	26585
006	„Abdeckschild „Sennheiser Logo“ „Cover plate „Sennheiser Logo“	46650
006a	Typenschild EK 2014 Type plate EK 2014	44450
006b	Typenschild EK 2014-TVL Type plate EK 2014-TVL	44452
007	Abdeckung Plastic Cover	14967
008	Zylinderschraube, 10 Stck. M 1,4 x 8 DIN 84 Cylindrical screw, 10 pcs. M 1,4 X 8 DIN 84	27156
009	4-Kantmutter, SW 3 x 1,5, M 1,4 Square nut, SW 3 x 1,5, M 1,4	26584
010	Scheibe, 10 Stck., 1,5 DIN 433 Washer, 10 pcs., 1,5 DIN 433	15858
011	Batteriekontaktierung Battery contact	26233
012	Zylinderschraube 10 Stck., M 1,4 x 6 DIN 84 Cylindrical screw, 10 pcs, M 1,4 x 6 DIN 84	15836
013	Achse Axis	14898
014	Senkschraube, 10 Stck. M 2 x 5 DIN 966 Countersunk screw, 10 pcs. M 2 x 5 DIN 966	26215
015	Riegel Locking	14899
016	Riegel Locking	14915
017	Feder Spring	26578
018	Zylinderschraube, 10 Stck., M 2 x 3 DIN 84 Cylindrical screw, 10 pcs., M 2 x 3 DIN 84	22460
019	Polster Pad	16134
020	Schlüssel Key	19050
021	Anschlußkabel, MKE 10-B2 Connecting cable, MKE 10-B2	44092
022	Antenne Antenna	27717
023	Schrumpfschlauch Shrinking tube	43347
024	Zylinderschraube, 10 Stck., M 1,4 x 3, DIN 84 Cylindrical screw, 10 pcs., M 1,4 x 3, DIN 84	22450
C001	SMD-Kondensator/Capacitor (50 Stck./pcs.) KERKO 1nF, 50 V, NPO,KEFQ 0805	19512
C002	SMD-Kondensator/Capacitor (50 Stck./pcs.) KERKO 1nF, 50 V, NPO,KEFQ 0805	19512
C003	SMD-Kondensator/Capacitor (50 Stck./pcs.) KERKO 1nF, 50 V, NPO,KEFQ 0805	19512
C004	SMD-Kondensator/Capacitor (50 Stck./pcs.) KERKO 1nF, 50 V, NPO,KEFQ 0805	19512
C005	SMD-Kondensator/Capacitor (50 Stck./pcs.) KERKO 1nF, 50 V, NPO,KEFQ 0805	19512
C006	Kondensator/Capacitor TA-ELKO 2,2 µF, 10 V ERO-ETUW 3	24430
C007	SMD-Kondensator/Capacitor (50 Stck./pcs.) KERKO 1nF, 50 V, NPO,KEFQ 0805	19512
C008	SMD-Kondensator/Capacitor (50 Stck./pcs.) KERKO 18 pF, 50 V, N150 ,KEFQ 0805	29576

Pos. Nr. Pos. No.	Bezeichnung Description	Bestell- Nr. Part No.
C009	SMD-Kondensator/Capacitor (50 Stck./pcs.) KERKO 10 nF, 50 V, X7R, KEFQ 0805	17648
C010	SMD-Kondensator/Capacitor (50 Stck./pcs.) KERKO 15 pF, 50 V, N150 ,KEFQ 0805	29574
C011	SMD-Kondensator/Capacitor (50 Stck./pcs.) KERKO 10 nF, 50 V, X7R, KEFQ 0805	17648
C012	SMD-Kondensator/Capacitor (50 Stck./pcs.) KERKO 2,2 nF, 50 V, X7R, KEFQ 0805	28693
C013	SMD-Kondensator/Capacitor (50 Stck./pcs.) KERKO 2,2 nF, 50 V, X7R, KEFQ 0805	28693
C014	SMD-Kondensator/Capacitor (50 Stck./pcs.) KERKO 1nF, 50 V, NPO,KEFQ 0805	19512
C015	SMD-Kondensator/Capacitor (50 Stck./pcs.) KERKO 22 pF, 50 V, NPO,KEFQ 0805	19584
C016	SMD-Kondensator/Capacitor (50 Stck./pcs.) KERKO 1nF, 50 V, NPO,KEFQ 0805	19512
C017	SMD-Kondensator/Capacitor (50 Stck./pcs.) KERKO 120 pF, 50 V, NPO, KEFQ 0805	29118
C018	SMD-Kondensator/Capacitor (50 Stck./pcs.) KERKO 56 pF, 50 V, NPO,KEFQ 0805	29145
C019	SMD-Kondensator/Capacitor (50 Stck./pcs.) KERKO 2,2 nF, 50 V, X7R, KEFQ 0805	28693
C020	SMD-Kondensator/Capacitor (50 Stck./pcs.) KERKO 270 pF, 50 V, NPO, KEFQ 0805	29148
C021	SMD-Kondensator/Capacitor (50 Stck./pcs.) KERKO 270 pF, 50 V, NPO, KEFQ 0805	29148
C022	SMD-Kondensator/Capacitor (50 Stck./pcs.) KERKO 2,2 nF, 50 V, X7R, KEFQ 0805	28693
C023	SMD-Kondensator/Capacitor (50 Stck./pcs.) KERKO 2,2 nF, 50 V, X7R, KEFQ 0805	28693
C024	SMD-Kondensator/Capacitor (50 Stck./pcs.) KERKO 470 pF, 50 V, NPO, KEFQ 0805	19479
C025	SMD-Kondensator/Capacitor (50 Stck./pcs.) KERKO 10 pF, 50 V, NPO,KEFQ 0805	19617
C026	SMD-Kondensator/Capacitor (50 Stck./pcs.) KERKO 470 pF, 50 V, NPO, KEFQ 0805	19479
C027	SMD-Kondensator/Capacitor (50 Stck./pcs.) KERKO 12 pF, 50 V, N330, KEFQ 0805	37006
C028	SMD-Kondensator/Capacitor (50 Stck./pcs.) KERKO 12 pF, 50 V, N330, KEFQ 0805	37006
C029	SMD-Kondensator/Capacitor (50 Stck./pcs.) KERKO 1nF, 50 V, NPO,KEFQ 0805	19512
C030	SMD-Kondensator/Capacitor (50 Stck./pcs.) KERKO 1nF, 50 V, NPO,KEFQ 0805	19512
C032	SMD-Kondensator/Capacitor (50 Stck./pcs.) KERKO 1nF, 50 V, NPO,KEFQ 0805	19512
C033	SMD-Kondensator/Capacitor (50 Stck./pcs.) KERKO 15 pF, 50 V, N150, KEFQ 0805	29574
C034	SMD-Kondensator/Capacitor (50 Stck./pcs.) KERKO 1nF, 50 V, NPO,KEFQ 0805	19512
C035	SMD-Kondensator/Capacitor (50 Stck./pcs.) KERKO 1nF, 50 V, NPO,KEFQ 0805	19512
C036	SMD-Kondensator/Capacitor (50 Stck./pcs.) KERKO 2,2 nF, 50 V, X7R, KEFQ 0805	28693
C037	SMD-Kondensator/Capacitor (50 Stck./pcs.) KERKO 2,2 nF, 50 V, X7R, KEFQ 0805	28693
C038	SMD-Kondensator/Capacitor (50 Stck./pcs.) KERKO 2,2 nF, 50 V, X7R, KEFQ 0805	28693
C039	SMD-Kondensator/Capacitor (50 Stck./pcs.) KERKO 1,8 pF, 50 V, NPO,KEFQ 0805	29562
C040	SMD-Kondensator/Capacitor (50 Stck./pcs.) KERKO 2,2 nF, 50 V, X7R, KEFQ 0805	28693
C041	SMD-Kondensator/Capacitor (50 Stck./pcs.) KERKO 100 pF, 50 V, N150, KEFQ 0805	32908
C042	SMD-Kondensator/Capacitor (50 Stck./pcs.) KERKO 2,2 nF, 50 V, X7R, KEFQ 0805	28693
C043	SMD-Kondensator/Capacitor (50 Stck./pcs.) KERKO 2,2 nF, 50 V, X7R, KEFQ 0805	28693
C044	SMD-Kondensator/Capacitor (50 Stck./pcs.) KERKO 2,2 nF, 50 V, X7R, KEFQ 0805	28693

Pos. Nr. Pos. No.	Bezeichnung Description	Bestell-Nr. Part No.
C045	SMD-Kondensator/Capacitor (50 Stck./pcs.) KERKO 2,2 nF, 50 V, X7R, KEFQ 0805	28693
C046	SMD-Kondensator/Capacitor (50 Stck./pcs.) KERKO 22 nF, 50 V, X7R, KEFQ 0805	32118
C047	SMD-Kondensator/Capacitor (50 Stck./pcs.) KERKO 1,2 nF, 50 V, X7R, KEFQ 0805	28818
C048	SMD-Kondensator/Capacitor TA-ELKO IEC 384.3	45043
C049	Kondensator/Capacitor TA-KO 10 µF, 16 V ERO-ETPW 2	27134
C050	Kondensator/Capacitor TA-ELKO 2,2 µF, 10 V ERO-ETUW 3	24430
C052	Kondensator/Capacitor TA-KO 33µF, 20 V ERO-ETPW 3	24539
C054	Kondensator/Capacitor TA-ELKO 2,2 µF, 10 V ERO-ETUW 3	24430
C055	Kondensator/Capacitor TA-ELKO 2,2 µF, 10 V ERO-ETUW 3	24430
C056	Kondensator/Capacitor TA-KO 33µF, 20 V ERO-ETPW 3	24539
C057	Kondensator/Capacitor TA-ELKO 2,2 µF, 10 V ERO-ETUW 3	24430
C058	Kondensator/Capacitor TA-ELKO 2,2 µF, 10 V ERO-ETUW 3	24430
C059	SMD-Kondensator/Capacitor (50 Stck./pcs.) KERKO 22 pF, 50 V, NPO, KEFQ 0805	19584
C060	SMD-Kondensator/Capacitor (50 Stck./pcs.) KERKO 100 pF, 50 V, N150, KEFQ 0805	32908
C061	Kondensator/Capacitor TA-ELKO 2,2 µF, 10 V ERO-ETUW 3	24430
C062	SMD-Kondensator/Capacitor (50 Stck./pcs.) KERKO 1nF, 50 V, NPO, KEFQ 0805	19512
C063	Kondensator/Capacitor TA-KO 33µF, 20 V ERO-ETPW 3	24539
C064	SMD-Kondensator/Capacitor (50 Stck./pcs.) KERKO 10 nF, 50 V, X7R, KEFQ 0805	17648
C065	Kondensator/Capacitor AL-ELKO 47 µF, 6,3 V	24544
C066	Kondensator/Capacitor TA-KO 10 µF, 16 V ERO-ETPW 2	27134
C067	Kondensator/Capacitor TA-KO 22 µF, 6,3 V ERO-ETPW 2	24518
C068	SMD-Kondensator/Capacitor (50 Stck./pcs.) KERKO 12 pF, 50 V, N330, KEFQ 0805 (702-960 MHz)	37006
C068	SMD-Kondensator/Capacitor (50 Stck./pcs.) KERKO 39 pF, 50 V, N150, KEFQ 0805 (450-702 MHz)	32921
C069	C-Trimmer/Potentiometer 0,4pF/2,5pF, NPO	44145
C070	C-Trimmer/Potentiometer 0,4pF/2,5pF, NPO	44145
C071	C-Trimmer/Potentiometer 0,4pF/2,5pF, NPO	44145
C072	C-Trimmer/Potentiometer 0,4pF/2,5pF, NPO	44145
C073	C-Trimmer/Potentiometer 0,4pF/2,5pF, NPO	44145
C074	C-Trimmer/Potentiometer 0,4pF/2,5pF, NPO	44145
C075	SMD-Kondensator/Capacitor (50 Stck./pcs.) KERKO 220 pF, 50 V, NPO, KEFQ 0805	29112
C076	SMD-Kondensator/Capacitor (50 Stck./pcs.) KERKO 1nF, 50 V, NPO, KEFQ 0805	19512
C077	SMD-Kondensator/Capacitor (50 Stck./pcs.) KERKO 1nF, 50 V, NPO, KEFQ 0805	19512
C101	Kondensator/Capacitor TA-ELKO 2,2 µF, 10 V, ERO-ETUW 3	24430
C102	SMD-Kondensator/Capacitor (50 Stck./pcs.) KERKO KEFQ120 pF, 50 V, NPO	29118
C103	SMD-Kondensator/Capacitor (50 Stck./pcs.) KERKO KEFQ 47 nF, 50 V, X7R	17630

Pos. Nr. Pos. No.	Bezeichnung Description	Bestell-Nr. Part No.
D001	SMD-Halbleiter/Semiconductor SMD-Diode, BAT 85	16276
D003	Halbleiter/Semiconductor SMD-Diode BAS16, SOT 23	32463
D101	Halbleiter/Semiconductor SMD-2-Sky-Diode, BAT 74, SOT 143	45015
D102	Halbleiter/Semiconductor SMD-Z-Diode ZMM 6,8-2	29995
D104	Halbleiter/Semiconductor SMD-Diode, BAT 74, SOT 143	45015
D105a	Isolierrohr für D105 Insulating tube for D105	11944
D105	LED, rot LED, red	44140
L001	HF-Spule RF-coil	44420
L003	HF-Spule RF-coil	44475
L004	HF-Spule RF-coil	44476
L005	HF-Spule RF-coil	44474
L006	HF-Spule RF-coil	44477
L007	HF-Spule RF-coil	44476
L008	HF-Spule RF-coil	44474
L009	HF-Trafo/RF-Transformer 72 MHz TOKO 210SN.124.R	45111
L010	HF-Trafo/RF-Transformer 72 MHz TOKO 210SN.124.R	45111
L011	SMD-Spule SMD-coil	34676
L012	HF-Spule RF-coil	42366
L013	HF-Spule RF-coil	43989
L014	SMD-Spule SMD-coil	40091
L015	SMD-Spule SMD-coil	40852
L016	SMD-Spule SMD-coil	40091
L017	HF-Spule RF-coil	43988
L019	HF-Spule RF-coil	44478
L020	HF-Spule RF-coil	44479
L021	HF-Spule RF-coil	36682
P001	HF-Kontakt RF-Contact	27719
P002	HF-Kontakt RF-Contact	27719
P003	Stiftleiste Pin strip	27721
P004	Stiftleiste Pin strip	27721
Q001	Halbleiter/Semiconductor SMD-FET S 933 T	40851
Q002	Halbleiter/Semiconductor SMD-FET CF 930 B	37194
Q003	Halbleiter/Semiconductor SMD-FET SST 309	40782
Q004	Halbleiter/Semiconductor SMD-Trans. BFS 20, SOT 23	24134
Q005	Halbleiter/Semiconductor SMD-Trans. BC 850 C, SOT 23	21165

Pos. Nr. Pos. No.	Bezeichnung Description	Bestell-Nr. Part No.
Q006	Halbleiter/Semiconductor SMD-FET S 933 T	40851
Q007	Halbleiter/Semiconductor SMD-Trans. BFR 93 A, SOT 23	41278
Q008	Halbleiter/Semiconductor SMD-FET BSS 138	44139
Q009	Halbleiter/Semiconductor SMD-Trans. BC 860 B, SOT 23	32468
Q010	Halbleiter/Semiconductor SMD-Trans. BC 850 B, SOT 23	32467
Q101	Halbleiter/Semiconductor SMD-Trans. BC 860 B, SOT 23	32468
Q102	Halbleiter/Semiconductor SMD-Trans. BC 850 B, SOT 23	32467
Q103	Halbleiter/Semiconductor SMD-Trans. BC 850 B, SOT 23	32467
Q104	Halbleiter/Semiconductor SMD-Trans. ZTX 650	23492
Q105	Halbleiter/Semiconductor SMD-Trans. BC 860 B, SOT 23	32468
R001	SMD-Widerstand/Resistor (50 Stck./pcs.) 180 Ω, 5 %, 0805	29161
R002	SMD-Widerstand/Resistor (50 Stck./pcs.) 4,7 KΩ, 5 %, 0805	29100
R003	SMD-Widerstand/Resistor (50 Stck./pcs.) 10 Ω, 5 %, 0805	29088
R004	SMD-Widerstand/Resistor (50 Stck./pcs.) 10 Ω, 5 %, 0805	29088
R005	SMD-Widerstand/Resistor (50 Stck./pcs.) 10 Ω, 5 %, 0805	29088
R006	SMD-Widerstand/Resistor (50 Stck./pcs.) 100 Ω, 5 %, 0805	29091
R007	SMD-Widerstand/Resistor (50 Stck./pcs.) 1 KΩ, 5 %, 0805	29096
R008	SMD-Widerstand/Resistor (50 Stck./pcs.) 100 Ω, 5 %, 0805	29091
R009	SMD-Widerstand/Resistor (50 Stck./pcs.) 100 Ω, 5 %, 0805	29091
R010	SMD-Widerstand/Resistor (50 Stck./pcs.) 82 KΩ, 5 %, 0805	29169
R011	SMD-Widerstand/Resistor (50 Stck./pcs.) 3,3 KΩ, 5 %, 0805	29098
R012	SMD-Widerstand/Resistor (50 Stck./pcs.) 39 KΩ, 5 %, 0805	29106
R013	SMD-Widerstand/Resistor (50 Stck./pcs.) 8,2 KΩ, 5 %, 0805	29102
R014	SMD-Widerstand/Resistor (50 Stck./pcs.) 220 Ω, 5 %, 0805	29092
R015	SMD-Widerstand/Resistor (50 Stck./pcs.) 100 Ω, 5 %, 0805	29091
R016	SMD-Widerstand/Resistor (50 Stck./pcs.) 1 KΩ, 5 %, 0805	29096
R017	SMD-Widerstand/Resistor (50 Stck./pcs.) 680 Ω, 5 %, 0805	29095
R018	SMD-Widerstand/Resistor (50 Stck./pcs.) 220 Ω, 5 %, 0805	29092
R019	SMD-Widerstand/Resistor (50 Stck./pcs.) 10 KΩ, 5 %, 0805	29103
R020	SMD-Widerstand/Resistor (50 Stck./pcs.) 100 Ω, 5 %, 0805	29091
R021	SMD-Widerstand/Resistor (50 Stck./pcs.) 330 Ω, 5 %, 0805	29093
R022	SMD-Widerstand/Resistor (50 Stck./pcs.) 680 Ω, 5 %, 0805	29095
R023	SMD-Widerstand/Resistor (50 Stck./pcs.) 10 KΩ, 5 %, 0805	29103
R024	SMD-Widerstand/Resistor (50 Stck./pcs.) 1 KΩ, 5 %, 0805	29096
R025	SMD-Widerstand/Resistor (50 Stck./pcs.) 100 Ω, 5 %, 0805	29091

Pos. Nr. Pos. No.	Bezeichnung Description	Bestell-Nr. Part No.
R026	SMD-Widerstand/Resistor (50 Stck./pcs.) 10 KΩ, 5 %, 0805	29103
R029	SMD-Widerstand/Resistor (50 Stck./pcs.) 82 Ω, 5 %, 0805	29160
R030	SMD-Widerstand/Resistor (50 Stck./pcs.) 100 Ω, 5 %, 0805	29091
R031	SMD-Widerstand/Resistor (50 Stck./pcs.) 330 Ω, 5 %, 0805	29093
R032	SMD-Widerstand/Resistor (50 Stck./pcs.) 100 KΩ, 5 %, 0805	29170
R033	SMD-Widerstand/Resistor (50 Stck./pcs.) 680 Ω, 5 %, 0805	29095
R034	SMD-Widerstand/Resistor (50 Stck./pcs.) 100 Ω, 5 %, 0805	29091
R035	SMD-Widerstand/Resistor (50 Stck./pcs.) 390 Ω, 5 %, 0805	32461
R036	SMD-Widerstand/Resistor (50 Stck./pcs.) 10 KΩ, 5 %, 0805	29103
R037	SMD-Widerstand/Resistor (50 Stck./pcs.) 10 KΩ, 5 %, 0805	29103
R039	SMD-Widerstand/Resistor (50 Stck./pcs.) 100 KΩ, 5 %, 0805	29170
R040	SMD-Widerstand/Resistor (50 Stck./pcs.) 100 KΩ, 5 %, 0805	29170
R041	SMD-R-Trimmer/Potentiometer 10 KΩ	45255
R042	SMD-Widerstand/Resistor (50 Stck./pcs.) 180 Ω, 5 %, 0805	29161
R043	SMD-Widerstand/Resistor (50 Stck./pcs.) 0 Ω, 0805	33113
R044	SMD-Widerstand/Resistor (50 Stck./pcs.) 0 Ω, 0805	33113
R045	SMD-Widerstand/Resistor (50 Stck./pcs.) 470 KΩ, 5 %, 0805	32822
R046	SMD-Widerstand/Resistor (50 Stck./pcs.) 5,6 KΩ, 5 %, 0805	29101
R047	SMD-Widerstand/Resistor (50 Stck./pcs.) 100 KΩ, 5 %, 0805	29170
R048	SMD-Widerstand/Resistor (50 Stck./pcs.) 18 KΩ, 5 %, 0805	29166
R049	R-Trimmer/Potentiometer 10 KΩ	39650
R051	SMD-Widerstand/Resistor (50 Stck./pcs.) 33 KΩ, 5 %, 0805	29121
R052	SMD-Widerstand/Resistor (50 Stck./pcs.) 47 KΩ, 5 %, 0805	29107
R053	SMD-Widerstand/Resistor (50 Stck./pcs.) 1 KΩ, 5 %, 0805	29096
R054	SMD-Widerstand/Resistor (50 Stck./pcs.) 150 Ω, 5 %, 0805	32110
R056	SMD-Widerstand/Resistor (50 Stck./pcs.) 150 Ω, 5 %, 0805	32110
R057	SMD-Widerstand/Resistor (50 Stck./pcs.) 47 Ω, 5 %, 0805	29169
R059	R-Trimmer/Potentiometer 1 KΩ	39650
R060	SMD-Widerstand/Resistor (50 Stck./pcs.) 10 Ω, 5 %, 0805	29088
R101	SMD-Widerstand/Resistor (50 Stck./pcs.) 47 KΩ, 5 %, 0805	29107
R102	SMD-Widerstand/Resistor (50 Stck./pcs.) 220 KΩ, 5 %, 0805	29122
R103	SMD-Widerstand/Resistor (50 Stck./pcs.) 56 KΩ, 5 %, 0805	29108
R104	SMD-Widerstand/Resistor (50 Stck./pcs.) 33 KΩ, 5 %, 0805	29121
R105	SMD-Widerstand/Resistor (50 Stck./pcs.) 27 KΩ, 5 %, 0805	29105
R106	SMD-Widerstand/Resistor (50 Stck./pcs.) 6,8 KΩ, 5 %, 0805	29120

Pos. Nr. Pos. No.	Bezeichnung Description	Bestell-Nr. Part No.
R107	SMD-Widerstand/Resistor (50 Stck./pcs.) 220 K Ω , 5 %, 0805	29122
R108	SMD-Widerstand/Resistor (50 Stck./pcs.) 10 K Ω , 5 %, 0805	29103
R109	SMD-R-Trimmer/Potentiometer 10 K Ω	46255
R110	SMD-Widerstand/Resistor (50 Stck./pcs.) 10 K Ω , 5 %, 0805	29103
R111	SMD-Widerstand/Resistor (50 Stck./pcs.) 470 K Ω , 5 %, 0805	32822
R112	SMD-Widerstand/Resistor (50 Stck./pcs.) 10 K Ω , 5 %, 0805	29103
R113	SMD-Widerstand/Resistor (50 Stck./pcs.) 47 K Ω , 5 %, 0805	29107
R114	SMD-Widerstand/Resistor (50 Stck./pcs.) 47 K Ω , 5 %, 0805	29107
R115	SMD-Widerstand/Resistor (50 Stck./pcs.) 1 M Ω , 5 %, 0805	29985
R116	SMD-Widerstand/Resistor (50 Stck./pcs.) 470 K Ω , 5 %, 0805	32822
R117	SMD-Widerstand/Resistor (50 Stck./pcs.) 2,2 K Ω , 5 %, 0805	29097
R118	SMD-Widerstand/Resistor (50 Stck./pcs.) 1 M Ω , 5 %, 0805	29985
S101a	Halterung für S101 Mounting for S101	15009
S101	Schiebeschalter Slide switch	26581
S102a	Halterung für S102 Mounting for S102	15009
S102	Schiebeschalter Slide switch	26581
T101	Trafo Transformer	24501
Tr001	HF-Baluntrafo RF-balun-transformer	44141
Tr002	HF-Baluntrafo RF-balun-transformer	44141
U001	SMD-IC GN 2011 QTX	44138
U002	SMD-IC NE 604 AD	40874
U004	SMD-IC NE 575 D	40875
U005	SMD-IC NE 5534	25136
U101	SMD-IC LM 358 D	29114
Y005	Quarz Crystal 63,0000 MHz HC45U	17674
Y006	Quarz Crystal	44438
Y007	Quarz Crystal	44438
YF001	KER-Filter/Ceramic filter 10,7 MHz 180 K Murata	40588
YF002	KER-Filter/Ceramic filter 10,7 MHz 180 K Murata	40588
EK 2014 TV, 702 - 960 MHz		
001	Frontblech Front panel	34333
002	Klammer Clip	15851
003	Buchse für Klammer Socket for clip	26508
004	O-Ring O-ring	44878

Pos. Nr. Pos. No.	Bezeichnung Description	Bestell-Nr. Part No.
005	Schlitzmutter Slotted nut	26585
006	„Abdeckschild „Sennheiser Logo“ „Cover plate „Sennheiser Logo“	46650
006a	Typenschild EK 2014 Type plate EK 2014	44450
006b	Typenschild EK 2014-TVH Type plate EK 2014-TVH	44451
007	Abdeckung Plastic Cover	14957
008	Zylinderschraube, 10 Stck. M 1,4 x 8 DIN 84 Cylindrical screw, 10 pcs. M 1,4 x 8 DIN 84	27156
009	4-Kantmutter, SW 3 x 1,5, M 1,4 Square nut, SW 3 x 1,5, M 1,4	26584
010	Scheibe, 10 Stck., 1,5 DIN 433 Washer, 10 pcs., 1,5 DIN 433	15858
011	Batteriekontakttierung Battery contact	26233
012	Zylinderschraube 10 Stck., M 1,4 x 6 DIN 84 Cylindrical screw, 10 pcs. M 1,4 x 6 DIN 84	15836
013	Achse Axis	14898
014	Senkschraube, 10 Stck. M 2 x 5 DIN 966 Countersunk screw, 10 pcs. M 2 x 5 DIN 966	26215
015	Riegel Locking	14899
016	Riegel Locking	14915
017	Feder Spring	26578
018	Zylinderschraube, 10 Stck., M 2 x 3 DIN 84 Cylindrical screw, 10 pcs., M 2 x 3 DIN 84	22460
019	Polster Pad	16134
020	Schlüssel Key	19050
021	Anschlusskabel, MKE 10-B2 Connecting cable, MKE 10-B2	44092
022	Antenne Antenna	27717
023	Schrumpfschlauch Shrinking tube	43347
024	Zylinderschraube, 10 Stck., M 1,4 x 3, DIN 84 Cylindrical screw, 10 pcs., M 1,4 x 3, DIN 84	22450
C001	SMD-Kondensator/Capacitor (50 Stck./pcs.) KERKO 1nF, 50 V, NPO,KEFQ 0805	19512
C002	SMD-Kondensator/Capacitor (50 Stck./pcs.) KERKO 1nF, 50 V, NPO,KEFQ 0805	19512
C003	SMD-Kondensator/Capacitor (50 Stck./pcs.) KERKO 1nF, 50 V, NPO,KEFQ 0805	19512
C004	SMD-Kondensator/Capacitor (50 Stck./pcs.) KERKO 1nF, 50 V, NPO,KEFQ 0805	19512
C005	SMD-Kondensator/Capacitor (50 Stck./pcs.) KERKO 1nF, 50 V, NPO,KEFQ 0805	19512
C006	Kondensator/Capacitor TA-ELKO 2,2 μ F, 10 V ERO-ETUW 3	24430
C007	SMD-Kondensator/Capacitor (50 Stck./pcs.) KERKO 1nF, 50 V, NPO,KEFQ 0805	19512
C008	SMD-Kondensator/Capacitor (50 Stck./pcs.) KERKO 18 pF, 50 V, N150 ,KEFQ 0805	29576
C009	SMD-Kondensator/Capacitor (50 Stck./pcs.) KERKO 10 nF, 50 V, X7R, KEFQ 0805	17648
C010	SMD-Kondensator/Capacitor (50 Stck./pcs.) KERKO 15 pF, 50 V, N150 ,KEFQ 0805	29574
C011	SMD-Kondensator/Capacitor (50 Stck./pcs.) KERKO 10 nF, 50 V, X7R, KEFQ 0805	17648
C012	SMD-Kondensator/Capacitor (50 Stck./pcs.) KERKO 2,2 nF, 50 V, X7R, KEFQ 0805	28693
C013	SMD-Kondensator/Capacitor (50 Stck./pcs.) KERKO 2,2 nF, 50 V, X7R, KEFQ 0805	28693

Pos. Nr. Pos. No.	Bezeichnung Description	Bestell-Nr. Part No.
C014	SMD-Kondensator/Capacitor (50 Stck./pcs.) KERKO 1nF, 50 V, NPO,KEFQ 0805	19512
C015	SMD-Kondensator/Capacitor (50 Stck./pcs.) KERKO 22 pF, 50 V, NPO,KEFQ 0805	19584
C016	SMD-Kondensator/Capacitor (50 Stck./pcs.) KERKO 1nF, 50 V, NPO,KEFQ 0805	19512
C017	SMD-Kondensator/Capacitor (50 Stck./pcs.) KERKO 120 pF, 50 V, NPO, KEFQ 0805	29118
C018	SMD-Kondensator/Capacitor (50 Stck./pcs.) KERKO 56 pF, 50 V, NPO, KEFQ 0805	29145
C019	SMD-Kondensator/Capacitor (50 Stck./pcs.) KERKO 2,2 nF, 50 V, X7R, KEFQ 0805	28693
C020	SMD-Kondensator/Capacitor (50 Stck./pcs.) KERKO 270 pF, 50 V, NPO, KEFQ 0805	29148
C021	SMD-Kondensator/Capacitor (50 Stck./pcs.) KERKO 270 pF, 50 V, NPO, KEFQ 0805	29148
C022	SMD-Kondensator/Capacitor (50 Stck./pcs.) KERKO 2,2 nF, 50 V, X7R, KEFQ 0805	28693
C023	SMD-Kondensator/Capacitor (50 Stck./pcs.) KERKO 2,2 nF, 50 V, X7R, KEFQ 0805	28693
C024	SMD-Kondensator/Capacitor (50 Stck./pcs.) KERKO 470 pF, 50 V, NPO, KEFQ 0805	19479
C025	SMD-Kondensator/Capacitor (50 Stck./pcs.) KERKO 10 pF, 50 V, NPO, KEFQ 0805	19617
C026	SMD-Kondensator/Capacitor (50 Stck./pcs.) KERKO 470 pF, 50 V, NPO, KEFQ 0805	19479
C027	SMD-Kondensator/Capacitor (50 Stck./pcs.) KERKO 12 pF, 50 V, N330, KEFQ 0805	37006
C028	SMD-Kondensator/Capacitor (50 Stck./pcs.) KERKO 12 pF, 50 V, N330, KEFQ 0805	37006
C029	SMD-Kondensator/Capacitor (50 Stck./pcs.) KERKO 1nF, 50 V, NPO,KEFQ 0805	19512
C030	SMD-Kondensator/Capacitor (50 Stck./pcs.) KERKO 1nF, 50 V, NPO,KEFQ 0805	19512
C031	SMD-Kondensator/Capacitor (50 Stck./pcs.) KERKO 4,7pF, 50 V, NPO, KEFQ 0805	17941
C032	SMD-Kondensator/Capacitor (50 Stck./pcs.) KERKO 1nF, 50 V, NPO,KEFQ 0805	19512
C033	SMD-Kondensator/Capacitor (50 Stck./pcs.) KERKO 12 pF, 50 V, N330, KEFQ 0805	37006
C034	SMD-Kondensator/Capacitor (50 Stck./pcs.) KERKO 1nF, 50 V, NPO,KEFQ 0805	19512
C035	SMD-Kondensator/Capacitor (50 Stck./pcs.) KERKO 1nF, 50 V, NPO,KEFQ 0805	19512
C036	SMD-Kondensator/Capacitor (50 Stck./pcs.) KERKO 2,2 nF, 50 V, X7R, KEFQ 0805	28693
C037	SMD-Kondensator/Capacitor (50 Stck./pcs.) KERKO 2,2 nF, 50 V, X7R, KEFQ 0805	28693
C038	SMD-Kondensator/Capacitor (50 Stck./pcs.) KERKO 2,2 nF, 50 V, X7R, KEFQ 0805	28693
C039	SMD-Kondensator/Capacitor (50 Stck./pcs.) KERKO 1,8 pF, 50 V, NPO,KEFQ 0805	29562
C040	SMD-Kondensator/Capacitor (50 Stck./pcs.) KERKO 2,2 nF, 50 V, X7R, KEFQ 0805	28693
C041	SMD-Kondensator/Capacitor (50 Stck./pcs.) KERKO 100 pF, 50 V, N150, KEFQ 0805	32908
C042	SMD-Kondensator/Capacitor (50 Stck./pcs.) KERKO 2,2 nF, 50 V, X7R, KEFQ 0805	28693
C043	SMD-Kondensator/Capacitor (50 Stck./pcs.) KERKO 2,2 nF, 50 V, X7R, KEFQ 0805	28693
C044	SMD-Kondensator/Capacitor (50 Stck./pcs.) KERKO 2,2 nF, 50 V, X7R, KEFQ 0805	28693
C045	SMD-Kondensator/Capacitor (50 Stck./pcs.) KERKO 2,2 nF, 50 V, X7R, KEFQ 0805	28693
C046	SMD-Kondensator/Capacitor (50 Stck./pcs.) KERKO 22 nF, 50 V, X7R, KEFQ 0805	32118
C047	SMD-Kondensator/Capacitor (50 Stck./pcs.) KERKO 1,2 nF, 50 V, X7R,KEFQ 0805	28818
C048	SMD-Kondensator/Capacitor TA-ELKO IEC 384.3	45043

Pos. Nr. Pos. No.	Bezeichnung Description	Bestell-Nr. Part No.
C049	Kondensator/Capacitor TA-KO 10 µF, 16 V ERO-ETPW 2	27134
C050	Kondensator/Capacitor TA-ELKO 2,2 µF, 10 V ERO-ETUW 3	24430
C052	Kondensator/Capacitor TA-KO 33µF, 20 V ERO-ETPW 3	24539
C054	Kondensator/Capacitor TA-ELKO 2,2 µF, 10 V ERO-ETUW 3	24430
C055	Kondensator/Capacitor TA-ELKO 2,2 µF, 10 V ERO-ETUW 3	24430
C056	Kondensator/Capacitor TA-KO 33µF, 20 V ERO-ETPW 3	24539
C057	Kondensator/Capacitor TA-ELKO 2,2 µF, 10 V ERO-ETUW 3	24430
C058	Kondensator/Capacitor TA-ELKO 2,2 µF, 10 V ERO-ETUW 3	24430
C059	SMD-Kondensator/Capacitor (50 Stck./pcs.) KERKO 22 pF, 50 V, NPO,KEFQ 0805	19584
C060	SMD-Kondensator/Capacitor (50 Stck./pcs.) KERKO 100 pF, 50 V, N150, KEFQ 0805	32908
C061	Kondensator/Capacitor TA-ELKO 2,2 µF, 10 V ERO-ETUW 3	24430
C062	SMD-Kondensator/Capacitor (50 Stck./pcs.) KERKO 1nF, 50 V, NPO,KEFQ 0805	19512
C063	Kondensator/Capacitor TA-KO 33µF, 20 V ERO-ETPW 3	24539
C064	SMD-Kondensator/Capacitor (50 Stck./pcs.) KERKO 10 nF, 50 V, X7R, KEFQ 0805	17648
C065	Kondensator/Capacitor AL-ELKO 47 µF, 6,3 V	24544
C066	Kondensator/Capacitor TA-KO 10 µF, 16 V ERO-ETPW 2	27134
C067	Kondensator/Capacitor TA-KO 22 µF, 6,3 V ERO-ETPW 2	24518
C068	SMD-Kondensator/Capacitor (50 Stck./pcs.) KERKO 12 pF, 50 V, N330, KEFQ 0805	37006
C069	C-Trimmiert/Potentiometer 0,4pF/2,5pF, NPO	44145
C070	C-Trimmiert/Potentiometer 0,4pF/2,5pF, NPO	44145
C071	C-Trimmiert/Potentiometer 0,4pF/2,5pF, NPO	44145
C072	C-Trimmiert/Potentiometer 0,4pF/2,5pF, NPO	44145
C073	C-Trimmiert/Potentiometer 0,4pF/2,5pF, NPO	44145
C074	C-Trimmiert/Potentiometer 0,4pF/2,5pF, NPO	44145
C075	SMD-Kondensator/Capacitor (50 Stck./pcs.) KERKO 220 pF, 50 V, NPO, KEFQ 0805	29112
C076	SMD-Kondensator/Capacitor (50 Stck./pcs.) KERKO 1nF, 50 V, NPO,KEFQ 0805	19512
C078	SMD-Kondensator/Capacitor (50 Stck./pcs.) KERKO 100 pF, 50 V, N150,KEFQ 0805	32908
C101	Kondensator/Capacitor TA-ELKO 2,2 µF, 10 V, ERO-ETUW 3	24430
C102	SMD-Kondensator/Capacitor (50 Stck./pcs.) KERKO KEFQ120 pF, 50 V, NPO	29118
C103	SMD-Kondensator/Capacitor (50 Stck./pcs.) KERKO KEFQ 47 nF, 50 V, X7R	17630
D001	Halbleiter/Semiconductor SMD-Diode, BAT 85	16276
D003	Halbleiter/Semiconductor SMD-Diode BAS16, SOT 23	32463
D101	Halbleiter/Semiconductor SMD-2-Sky-Diode, BAT 74, SOT 143	45015
D102	Halbleiter/Semiconductor SMD-Z-Diode ZMM 6,8-2	29995
D104	Halbleiter/Semiconductor SMD-Diode, BAT 74, SOT 143	45015

Pos. Nr. Pos. No.	Bezeichnung Description	Bestell- Nr. Part No.
D105a	Isolierrohr für D105 Insulating tube for D105	11944
D105	LED, rot LED, red	44140
L001	HF-Spule RF-coil	44420
L003	HF-Spule RF-coil	44459
L004	HF-Spule RF-coil	42867
L005	HF-Spule RF-coil	44420
L006	HF-Spule RF-coil	44459
L007	HF-Spule RF-coil	44463
L008	HF-Spule RF-coil	44419
L009	HF-Trafo/RF-Transformer 72 MHz TOKO 210SN.124.R	45111
L010	HF-Trafo/RF-Transformer 72 MHz TOKO 210SN.124.R	45111
L011	SMD-Spule SMD-coil	34676
L012	HF-Spule RF-coil	42366
L013	HF-Spule RF-coil	43989
L014	SMD-Spule SMD-coil	40091
L015	SMD-Spule SMD-coil	40852
L016	SMD-Spule SMD-coil	40091
L017	HF-Spule RF-coil	43968
L019	HF-Spule RF-coil	44463
L020	HF-Spule RF-coil	44461
L021	HF-Spule RF-coil	36882
P001	HF-Kontakt RF-Contact	27719
P002	HF-Kontakt RF-Contact	27719
P003	Stiftleiste Pin strip	27721
P004	Stiftleiste Pin strip	27721
Q001	Halbleiter/Semiconductor SMD-FET S 933 T	40851
Q002	Halbleiter/Semiconductor SMD-FET CF 930 B	37194
Q003	Halbleiter/Semiconductor SMD-FET SST 309	40792
Q004	Halbleiter/Semiconductor SMD-Trans. BFS 20, SOT 23	24134
Q005	Halbleiter/Semiconductor SMD-Trans. BC 850 C, SOT 23	21165
Q006	Halbleiter/Semiconductor SMD-FET S 933 T	40851
Q007	Halbleiter/Semiconductor SMD-Trans. BFR 93 A, SOT 23	41278
Q008	Halbleiter/Semiconductor SMD-FET BSS 138	44139
Q009	Halbleiter/Semiconductor SMD-Trans. BC 860 B, SOT 23	32468
Q010	Halbleiter/Semiconductor SMD-Trans. BC 850 B, SOT 23	32467

Pos. Nr. Pos. No.	Bezeichnung Description	Bestell- Nr. Part No.
Q101	Halbleiter/Semiconductor SMD-Trans. BC 860 B, SOT 23	32468
Q102	Halbleiter/Semiconductor SMD-Trans. BC 850 B, SOT 23	32467
Q103	Halbleiter/Semiconductor SMD-Trans. BC 850 B, SOT 23	32467
Q104	Halbleiter/Semiconductor SMD-Trans. ZTX 650	23492
Q105	Halbleiter/Semiconductor SMD-Trans. BC 860 B, SOT 23	32468
R001	SMD-Widerstand/Resistor (50 Stck./pcs.) 180 Ω, 5 %, 0805	29161
R002	SMD-Widerstand/Resistor (50 Stck./pcs.) 4,7 KΩ 5 %, 0805	29100
R003	SMD-Widerstand/Resistor (50 Stck./pcs.) 10 Ω, 5 %, 0805	29088
R004	SMD-Widerstand/Resistor (50 Stck./pcs.) 10 Ω, 5 %, 0805	29066
R005	SMD-Widerstand/Resistor (50 Stck./pcs.) 10 Ω, 5 %, 0805	29068
R006	SMD-Widerstand/Resistor (50 Stck./pcs.) 100 Ω, 5 %, 0805	29091
R007	SMD-Widerstand/Resistor (50 Stck./pcs.) 1 KΩ 5 %, 0805	29096
R008	SMD-Widerstand/Resistor (50 Stck./pcs.) 100 Ω, 5 %, 0805	29091
R009	SMD-Widerstand/Resistor (50 Stck./pcs.) 100 Ω, 5 %, 0805	29091
R010	SMD-Widerstand/Resistor (50 Stck./pcs.) 62 KΩ 5 %, 0805	29169
R011	SMD-Widerstand/Resistor (50 Stck./pcs.) 3,3 KΩ 5 %, 0805	29098
R012	SMD-Widerstand/Resistor (50 Stck./pcs.) 39 KΩ 5 %, 0805	29106
R013	SMD-Widerstand/Resistor (50 Stck./pcs.) 8,2 KΩ 5 %, 0805	29102
R014	SMD-Widerstand/Resistor (50 Stck./pcs.) 220 Ω, 5 %, 0805	29092
R015	SMD-Widerstand/Resistor (50 Stck./pcs.) 100 Ω, 5 %, 0805	29091
R016	SMD-Widerstand/Resistor (50 Stck./pcs.) 1 KΩ 5 %, 0805	29096
R017	SMD-Widerstand/Resistor (50 Stck./pcs.) 680 Ω 5 %, 0805	29095
R018	SMD-Widerstand/Resistor (50 Stck./pcs.) 220 Ω, 5 %, 0805	29092
R019	SMD-Widerstand/Resistor (50 Stck./pcs.) 10 KΩ 5 %, 0805	29103
R020	SMD-Widerstand/Resistor (50 Stck./pcs.) 100 Ω, 5 %, 0805	29091
R021	SMD-Widerstand/Resistor (50 Stck./pcs.) 330 Ω 5 %, 0805	29093
R022	SMD-Widerstand/Resistor (50 Stck./pcs.) 680 Ω 5 %, 0805	29095
R023	SMD-Widerstand/Resistor (50 Stck./pcs.) 10 KΩ 5 %, 0805	29103
R024	SMD-Widerstand/Resistor (50 Stck./pcs.) 1 KΩ 5 %, 0805	29096
R025	SMD-Widerstand/Resistor (50 Stck./pcs.) 100 Ω, 5 %, 0805	29091
R026	SMD-Widerstand/Resistor (50 Stck./pcs.) 10 KΩ 5 %, 0805	29103
R029	SMD-Widerstand/Resistor (50 Stck./pcs.) 82 Ω, 5 %, 0805	29160
R030	SMD-Widerstand/Resistor (50 Stck./pcs.) 100 Ω, 5 %, 0805	29091
R031	SMD-Widerstand/Resistor (50 Stck./pcs.) 330 Ω 5 %, 0805	29093
R032	SMD-Widerstand/Resistor (50 Stck./pcs.) 100 KΩ 5 %, 0805	29170

Pos. Nr. Pos. No.	Bezeichnung Description	Bestell-Nr. Part No.
R033	SMD-Widerstand/Resistor (50 Stck./pcs.) 680 Ω 5 %, 0805	29095
R034	SMD-Widerstand/Resistor (50 Stck./pcs.) 100 Ω, 5 %, 0805	29091
R035	SMD-Widerstand/Resistor (50 Stck./pcs.) 390 Ω 5 %, 0805	32461
R036	SMD-Widerstand/Resistor (50 Stck./pcs.) 10 KΩ 5 %, 0805	29103
R037	SMD-Widerstand/Resistor (50 Stck./pcs.) 10 KΩ 5 %, 0805	29103
R039	SMD-Widerstand/Resistor (50 Stck./pcs.) 100 KΩ 5 %, 0805	29170
R040	SMD-Widerstand/Resistor (50 Stck./pcs.) 100 KΩ 5 %, 0805	29170
R041	SMD-R-Trimmer/Potentiometer 10 KΩ	45255
R042	SMD-Widerstand/Resistor (50 Stck./pcs.) 180 Ω, 5 %, 0805	29161
R043	SMD-Widerstand/Resistor (50 Stck./pcs.) 0 Ω, 0805	33113
R044	SMD-Widerstand/Resistor (50 Stck./pcs.) 0 Ω, 0805	33113
R045	SMD-Widerstand/Resistor (50 Stck./pcs.) 470 KΩ 5 %, 0805	32822
R046	SMD-Widerstand/Resistor (50 Stck./pcs.) 5,6 KΩ 5 %, 0805	29101
R047	SMD-Widerstand/Resistor (50 Stck./pcs.) 100 KΩ 5 %, 0805	29170
R048	SMD-Widerstand/Resistor (50 Stck./pcs.) 18 KΩ 5 %, 0805	29166
R049	R-Trimmer/Potentiometer 10 KΩ	39650
R051	SMD-Widerstand/Resistor (50 Stck./pcs.) 33 KΩ 5 %, 0805	29121
R052	SMD-Widerstand/Resistor (50 Stck./pcs.) 47 KΩ 5 %, 0805	29107
R053	SMD-Widerstand/Resistor (50 Stck./pcs.) 1 KΩ 5 %, 0805	29096
R054	SMD-Widerstand/Resistor (50 Stck./pcs.) 150 Ω, 5 %, 0805	32110
R056	SMD-Widerstand/Resistor (50 Stck./pcs.) 150 Ω, 5 %, 0805	32110
R057	SMD-Widerstand/Resistor (50 Stck./pcs.) 47 Ω, 5 %, 0805	29159
R059	R-Trimmer/Potentiometer 1 KΩ	39650
R060	SMD-Widerstand/Resistor (50 Stck./pcs.) 10 Ω, 5 %, 0805	29088
R101	SMD-Widerstand/Resistor (50 Stck./pcs.) 47 KΩ, 5 %, 0805	29107
R102	SMD-Widerstand/Resistor (50 Stck./pcs.) 220 KΩ, 5 %, 0805	29122
R103	SMD-Widerstand/Resistor (50 Stck./pcs.) 56 KΩ, 5 %, 0805	29108
R104	SMD-Widerstand/Resistor (50 Stck./pcs.) 33 KΩ, 5 %, 0805	29121
R105	SMD-Widerstand/Resistor (50 Stck./pcs.) 27 KΩ, 5 %, 0805	29105
R106	SMD-Widerstand/Resistor (50 Stck./pcs.) 6,8 KΩ, 5 %, 0805	29120
R107	SMD-Widerstand/Resistor (50 Stck./pcs.) 220 KΩ, 5 %, 0805	29122
R108	SMD-Widerstand/Resistor (50 Stck./pcs.) 10 KΩ, 5 %, 0805	29103
R109	SMD-R-Trimmer/Potentiometer 10 KΩ	45255
R110	SMD-Widerstand/Resistor (50 Stck./pcs.) 10 KΩ, 5 %, 0805	29103
R111	SMD-Widerstand/Resistor (50 Stck./pcs.) 470 KΩ, 5 %, 0805	32822

Pos. Nr. Pos. No.	Bezeichnung Description	Bestell-Nr. Part No.
R112	SMD-Widerstand/Resistor (50 Stck./pcs.) 10 KΩ, 5 %, 0805	29103
R113	SMD-Widerstand/Resistor (50 Stck./pcs.) 47 KΩ, 5 %, 0805	29107
R114	SMD-Widerstand/Resistor (50 Stck./pcs.) 47 KΩ, 5 %, 0805	29107
R115	SMD-Widerstand/Resistor (50 Stck./pcs.) 1 MΩ, 5 %, 0805	29985
R116	SMD-Widerstand/Resistor (50 Stck./pcs.) 470 KΩ, 5 %, 0805	32822
R117	SMD-Widerstand/Resistor (50 Stck./pcs.) 2,2 KΩ, 5 %, 0805	29097
R118	SMD-Widerstand/Resistor (50 Stck./pcs.) 1 MΩ, 5 %, 0805	29985
S101a	Halterung für S101 Mounting for S101	15009
S101	Schiebeschalter Slide switch	26581
S102a	Halterung für S102 Mounting for S102	15009
S102	Schiebeschalter Slide switch	26581
T101	Trafo Transformer	24501
Tr001	HF-Baluntrafo RF-balun-transformer	44141
Tr002	HF-Baluntrafo RF-balun-transformer	44141
U001	SMD-IC GN 2011 QTX	44138
U002	SMD-IC NE 604 AD	40874
U004	SMD-IC NE 575 D	40875
U005	SMD-IC NE 5534	25136
U101	SMD-IC LM 358 D	29114
Y005	Quarz Crystal 63,0000 MHz HC45U	17674
Y006	Quarz Crystal	44438
Y007	Quarz Crystal	44438
YF001	KER-Filter/Ceramic filter 10,7 MHz 180 K Murata	40588
YF002	KER-Filter/Ceramic filter 10,7 MHz 180 X Murata	40588

Änderungen vorbehalten
Subject to alterations