

SERVICE MANUAL

PARTS LIST

AKAI AUTOMATIC TURNTABLE

MODEL **AP-004**

ALSO APPLICABLE TO MODEL AP-420,
AP-004X, AP-004D



AUTOMATIC TURNTABLE

MODEL AP-004

ALSO APPLICABLE TO MODEL AP-420,
AP-004X, AP-004D

SECTION 1	SERVICE MANUAL	3
SECTION 2	PARTS LIST	31

SECTION 1

SERVICE MANUAL

TABLE OF CONTENTS

I. SPECIFICATIONS	4
II. DISMANTLING OF UNIT	5
III. AUTOMATIC MECHANISM	6
(1) LEAD IN	8
(2) LEAD OUT	8
(3) CUT (REJECT)	8
(4) REPEAT	8
(5) MANUAL OPERATION (Lead in only)	8
IV. VARIOUS ADJUSTMENTS	17
(1) LEAD OUT POSITION	18
(2) LEAD IN POSITION	18
(3) CYCLE CHANGE (MOTOR PULLEY REPLACEMENT)	18
V. PLAYER CARE	19
1. LIFE OF NEEDLE (STYLUS TIP)	19
2. NEEDLE CHANGE	19
3. LUBRICATION	19
VI. BLOCK DIAGRAM	20
1. Models AP-420, AP-004 (A)	20
2. Models AP-004 (B), (C), AP-004D	20
VII. ADJUSTMENT CHART	23

I. SPECIFICATIONS

MODEL	AP-420	AP-004	AP-004D
1. TYPE	Belt Drive, Fully Automatic	Belt Drive, Fully Automatic	Belt Drive, Fully Automatic
2. CARTRIDGE	M,M Type APC-4	APC-2	M-91ED
3. OUTPUT VOLTAGE	1.1 mV to 2.6 mV 1,000 Hz, 50 mm/sec.	2.2 mV to 4.4 mV 1,000 Hz, 50 mm/sec.	2.2 mV to 6.0 mV 1,000 Hz, 50 mm/sec.
4. FREQUENCY RESPONSE	30 kHz 1.25 mV to 3.7 mV 10 kHz 0 dB±4 dB (1 kHz:0 dB)	30 kHz 1.25 mV to 3.7 mV 10 kHz 0 dB±4 dB (1 kHz:0 dB)	30 kHz 1.25 mV to 3.7 mV 10 kHz 0 dB±4 dB (1 kHz:0 dB)
5. CROSS TALK	Better than 15 dB, 1,000 Hz Better than 12 dB, 10 kHz Better than 10 dB, 30 kHz	Better than 15 dB, 1,000 Hz	Better than 15 dB, 1,000 Hz
6. OUTPUT BALANCE	Within 3 dB	Within 3 dB	Within 2.5 dB
7. COMPLIANCE	5 to 8×10^{-6} cm/dyne	5 to 8×10^{-6} cm/dyne	30×10^{-6} cm/dyne
8. STYLUS PRESSURE	2.0 gr±15%	2.0 gr±15%	1.5 gr±15%
9. STYLUS TIP	Parabolic polished tip APN-4	0.5 mil diamond tip APN-2	0.2x0.7mm Shure tip M-91ED
10. TONE ARM	Static balanced type with inside force canceller and lateral balance weight	Static balanced type with inside force canceller and lateral balance weight	Static balanced type with inside force canceller and lateral balance weight
11. MOTOR	4-pole synchronous motor for turntable drive and a geared motor (16-pole 4 r.p.m. synchronous) for tone arm drive.	4-pole synchronous motor for turntable drive and a geared motor (16-pole 4 r.p.m. synchronous) for tone arm drive.	4-pole synchronous motor for turntable drive and a geared motor (16-pole 4 r.p.m. synchronous) for tone arm drive
12. TURNTABLE	301 mm aluminium alloy diecast	301 mm aluminium alloy diecast	301 mm aluminium alloy diecast
13. REVOLUTIONS	33-1/3 and 45 r.p.m.	33-1/3 and 45 r.p.m.	33-1/3 and 45 r.p.m.
14. WOW/FLUTTER	Less than 0.14% (W.R.M.S.)	Less than 0.14% (W.R.M.S.)	Less than 0.14% (W.R.M.S.)
15. S/N RATIO	Better than 32 dB (JIS)	Better than 32 dB (JIS)	Better than 32 dB (JIS)
16. POWER CONSUMPTION	Less than 17W	Less than 17W	Less than 17W
17. DIMENSIONS	503(W)x185(H)x410(D)mm (19.8"x7.3"x16.2")	442(W)x185(H)x377(D)mm (17.4"x7.3"x14.8")	503(W)x185(H)x410(D)mm (19.8"x7.3"x16.2")
18. WEIGHT	9 kg. (19.8 lbs.)	8 kg. (17.6 lbs.)	9 kg. (19.8 lbs.)

II. DISMANTLING OF UNIT

In case of trouble, etc. necessitating disassembly, please disassemble in the order shown in photographs. Re-assemble in reverse order.

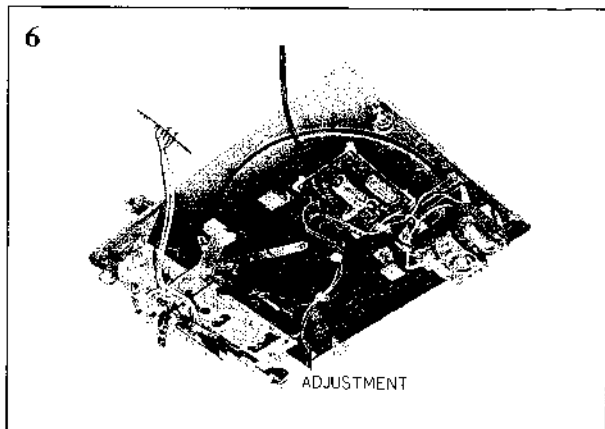
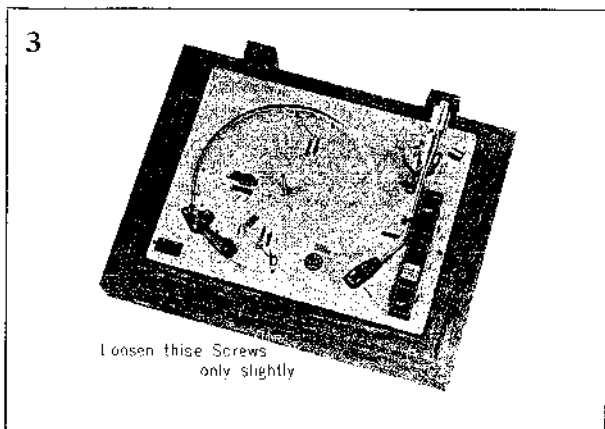
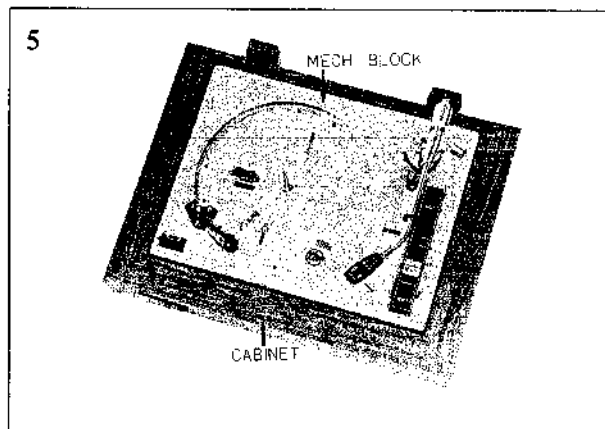
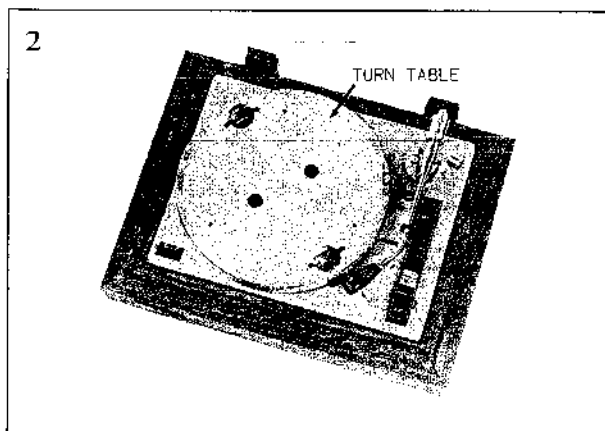
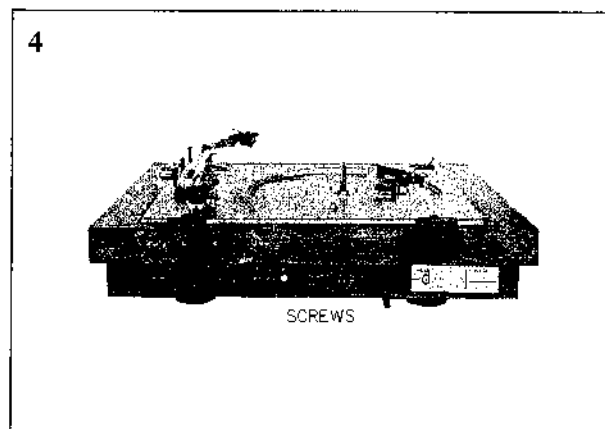
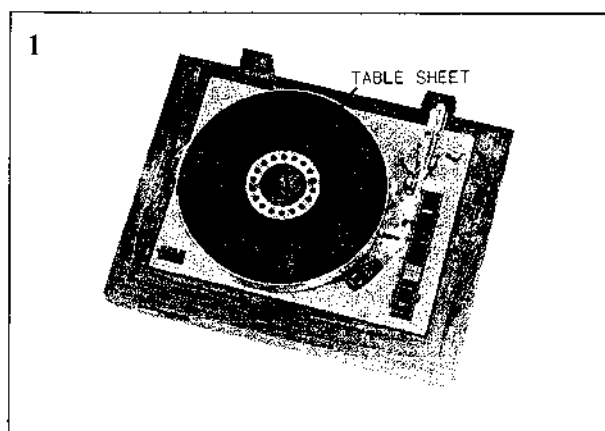

III. AUTOMATIC MECHANISM

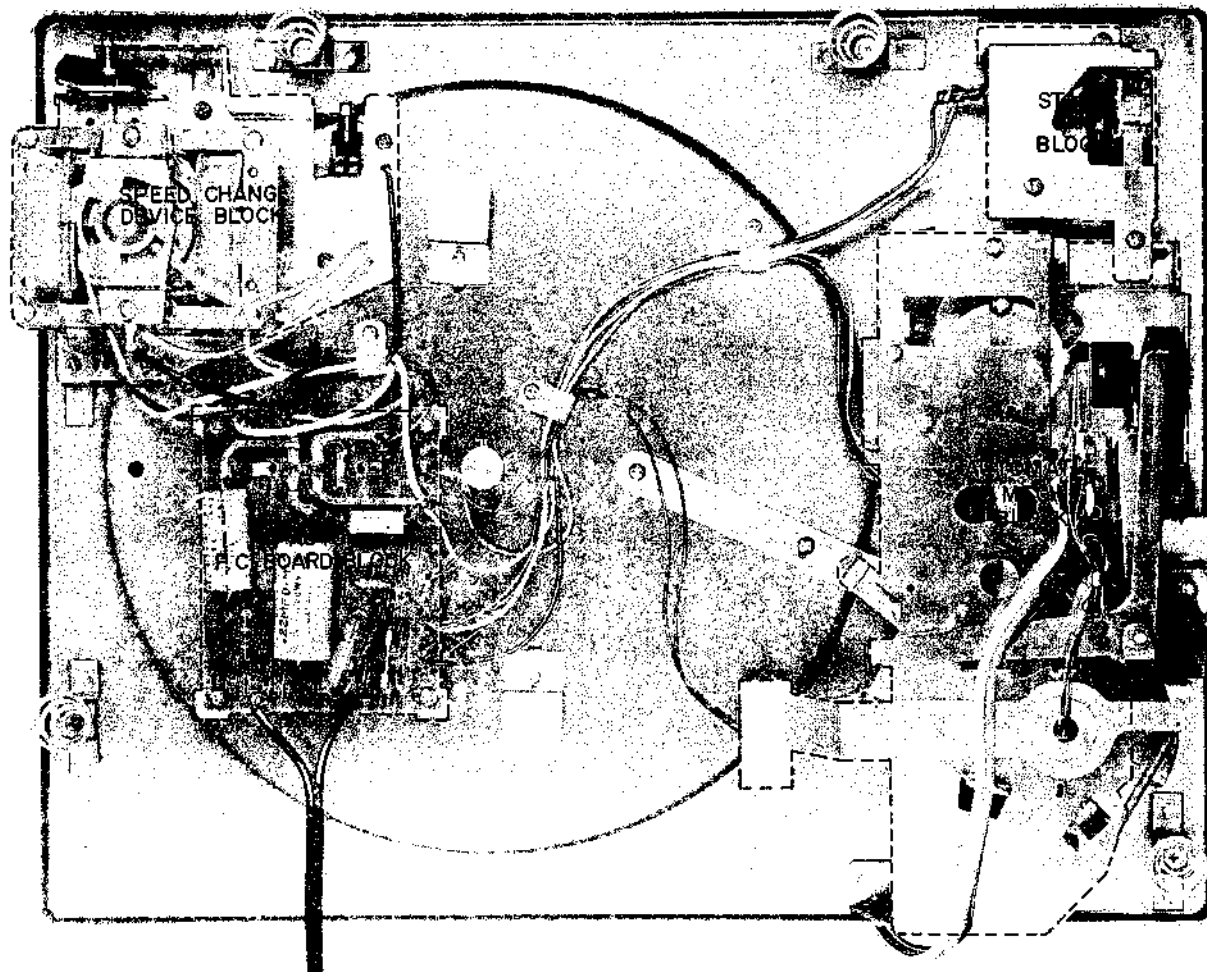

Fig. 1

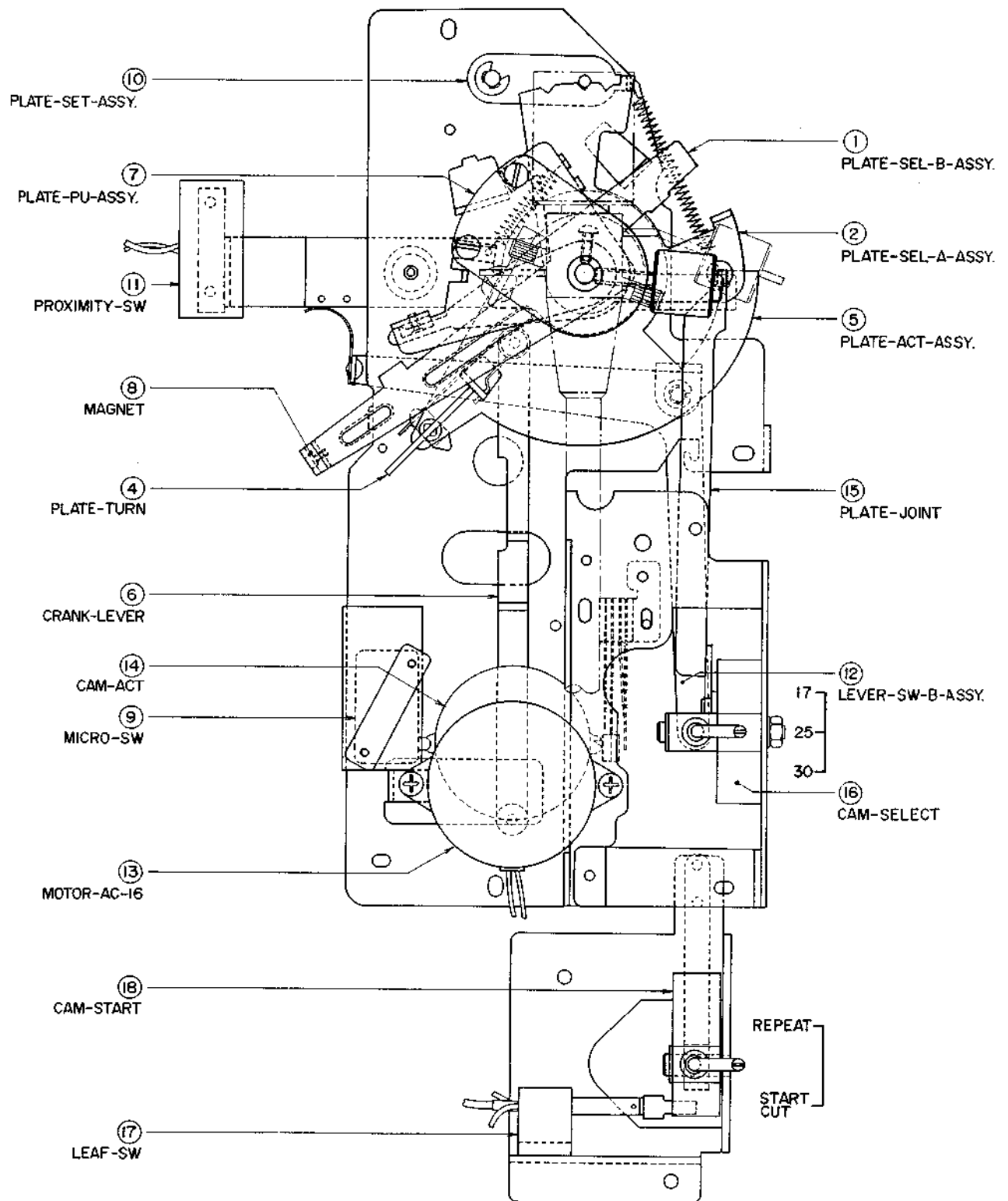

Fig. 2 MAIN PARTS OF AUTOMATIC MECHANISM

The automatic mechanism of this machine is as shown in Fig. 2. Confirm whether the size of your record is 30 cm, 25 cm, or 17 cm and set CAM-SELECT (16) to corresponding position. This CAM-SELECT (16) moves PLATE-SEL-A-ASSY (2) through PLATE JOINT (15) and the pick up arm is moved outward and stops at the outer circumference of the record. At the same time, SW-PROXIMITY (11) is moved through LEVER-SW-B-ASSY (12) and this becomes the perception equipment for determining the end of record performance.

(1) LEAD IN

When CAM-START knob (18) is manipulated in the direction of START CUT, SW-LEAF (17) operates and CAM-ACT (14) which is directly connected to MOTOR AC-16 (13) slowly rotates, and transmission to PLATE-ACT-ASSY (5) is made through LEVER-CRANK (6). (Refer to Fig. 3) PLATE-PU-ASSY (7) which is directly connected to the pick up arm shaft is operated by means of PLATE-TURN (4) until PLATE-SEL-A-ASSY (2) setting position while intervening PLATE-SEL-B-ASSY (1). (Refer to Fig. 4) Because PLATE-SEL-B-ASSY (1) does not operate after contacting PLATE-SEL-A-ASSY (2) motive power is applied and further, PLATE TURN (4) which is about to advance, is rotated 90° at this point. (Fig. 5) Further advancing CAM-ACT (14) makes 1/2 revolution and just before stopping is again rotated 90° by the pin under neath and stops. (Refer to Figs. 6 and 7). Also the pick-up arm lifter (position indicated by ⊗ mark in figure) is slowly set down by the slanted part of PLATE-ACT-ASSY (5) to effect record playback as shown in Fig. 7.

(2) LEAD OUT

As the pick-up arm advances during record performance, PLATE-PU-ASSY (7) which is directly connected to the revolving shaft also rotates and moves at a comparative volume, and MAGNET (8) which is installed on the tip part of this approaches SW-PROXIMITY (11). (Fig. 7)

Then when the pick-up needle reaches the lead out groove, MAGNET (8) reaches the perception point of SW-PROXIMITY (11) and MOTOR-AC-16 (13) and CAM-ACT (14) begins to rotate again. CAM-ACT (14) rotates in conforming direction (counter clockwise), but because of the reciprocating motion of LEVER-CRANK (6) at every 1/2 revolution, PLATE-ACT-ASSBY (5) begins to move again in the opposite direction from lead in time. That is to say, the lifter is raised by means of the slanted part of PLATE-ACT-ASSY (5), and PLATE-TURN (4), as shown in Fig. 8, pushes PLATE-PU-ASSY (7) back, and when the pickup arm is returned to the arm rest, rotates 90° (Fig. 9). Then immediately before the 1/2 revolution of CAM-ACT (14) ends, it is further rotated 90°. With this, lead out is completed and record player returned to the condition shown in Fig. 3.

* The perception point of SW-PROXIMITY (11) is a 2 stage switch and operates by means of CAM-SELECT (16) according to whether the record in 30/25 cm and 17 cm.

(3) CUT (REJECT)

When CAM-START KNOB (18) is manipulated toward START CUT to stop performance before the record ends, SW-LEAF (17) operates in the same way as SW-PROXIMITY (11) in Item (2), and lead out operation begins.

(4) REPEAT

In case CAM-START KNOB (18) is set to REPEAT position for listening to one side of a record over and over, even though the pick-up arm will return to the rest at the end of playback, because current continues to flow to MOTOR-AC-16 (13), lead in is repeated and operation begins again.

(5) MANUAL OPERATION (Lead in only)

When the pick-up arm stylus tip is lifted during performance (after the record tune or during performance) for movement by hand to a desired point, PLATE-MANUAL-B (19) which rides on PLATE-PU-ASSY (7) separates and drops as shown in Fig. 10.

At this condition if the knob of CAM-START (18) is moved to START CUT and PLATE-TURN (4) begins to operate, it is immediately obstructed by PLATE-MANUAL-B (19) and rotates 90°. (Fig. 11)

Therefore, the essential objective of PLATE-TURN (4) is to transport the PLATE-PU-ASSY (7), and when it does not carry out this purpose (is obstructed), the tone arm cannot be moved freely to any position on the record and playback begins from the point at which the stylus tip touches the record.

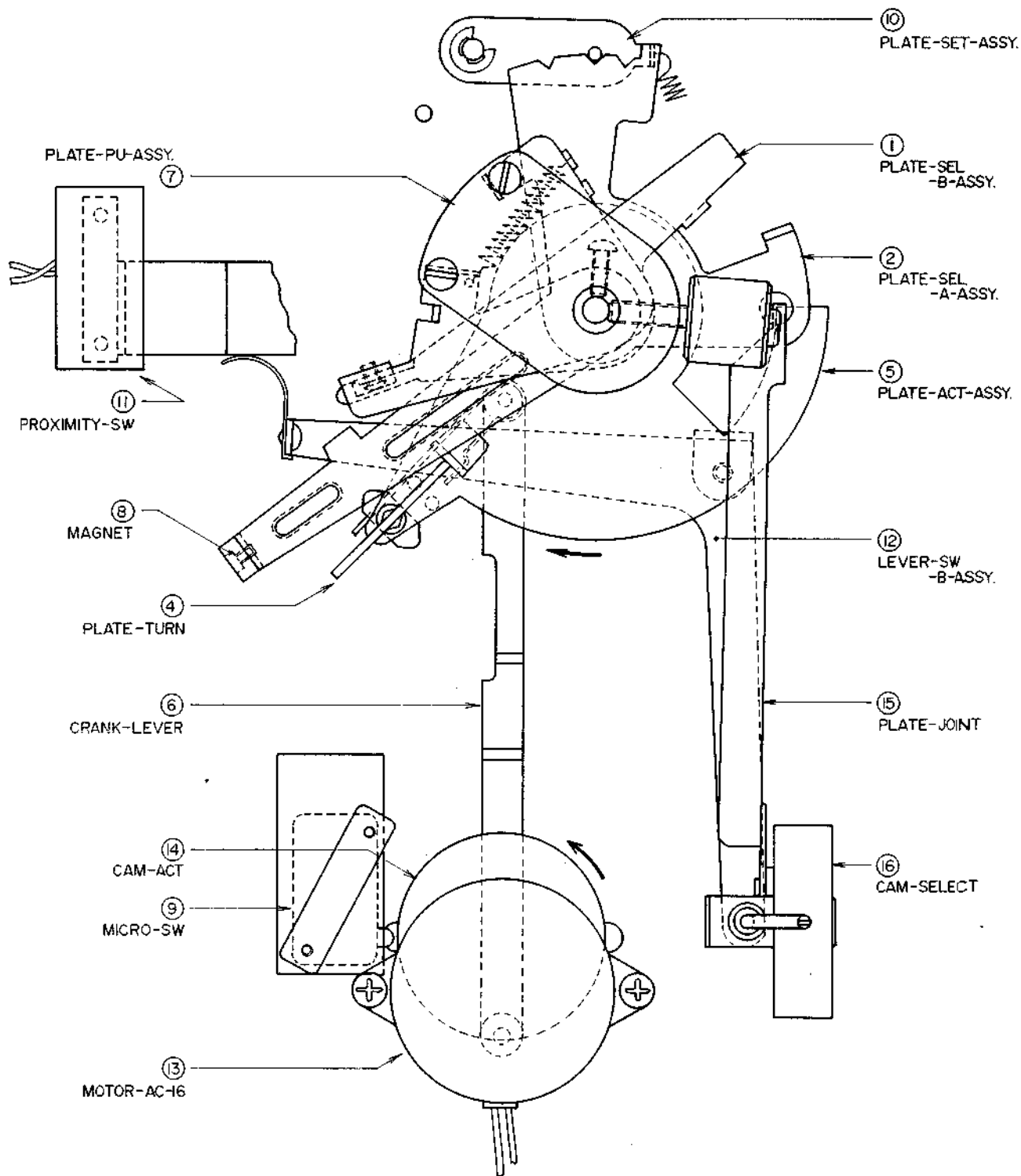

Fig. 3 Lead in Start condition, playback not yet effected.

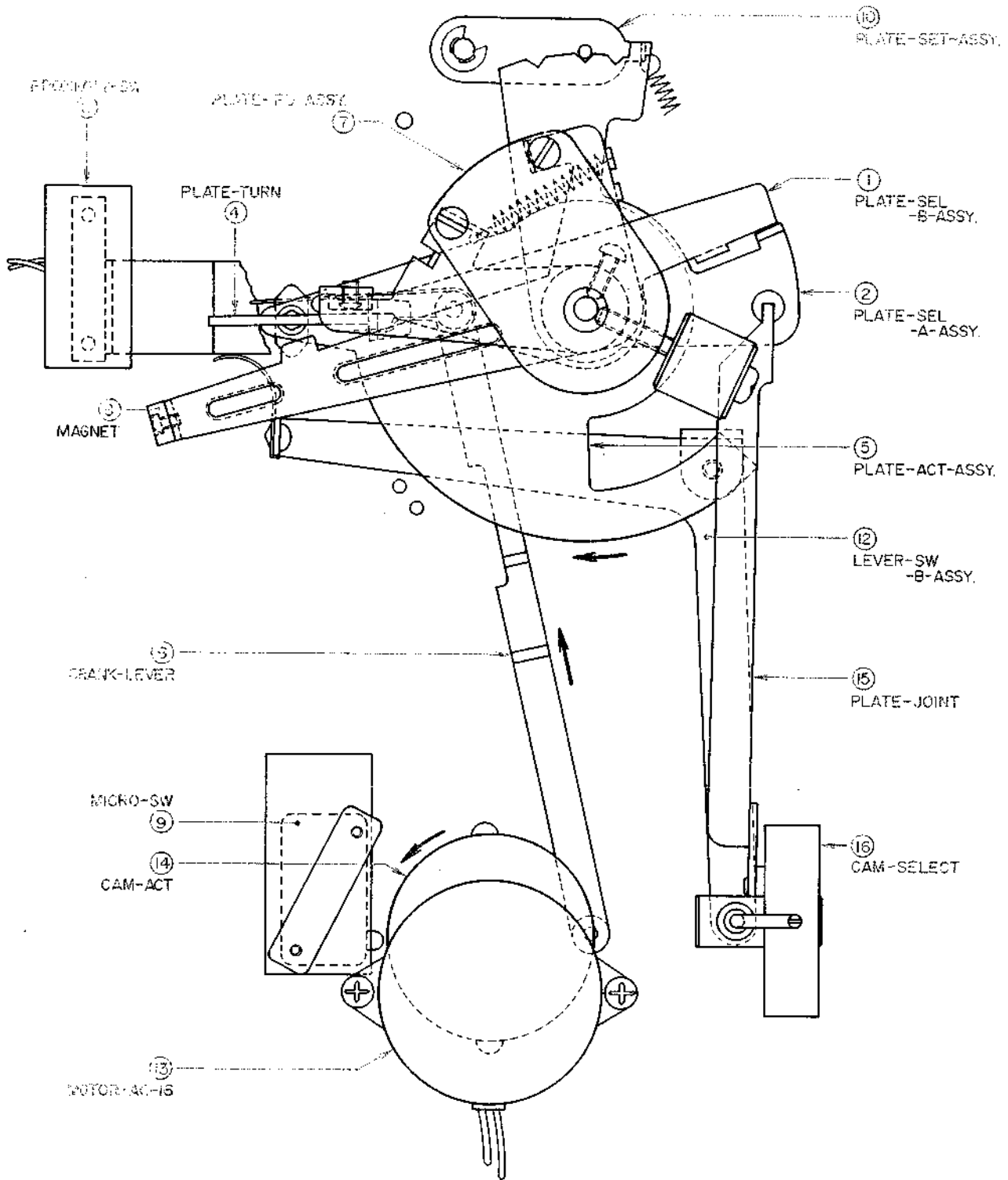

Fig. 4 Lead in condition, PU Arm horizontal movement complete (PU Arm at 25 cm of record outer circumference).

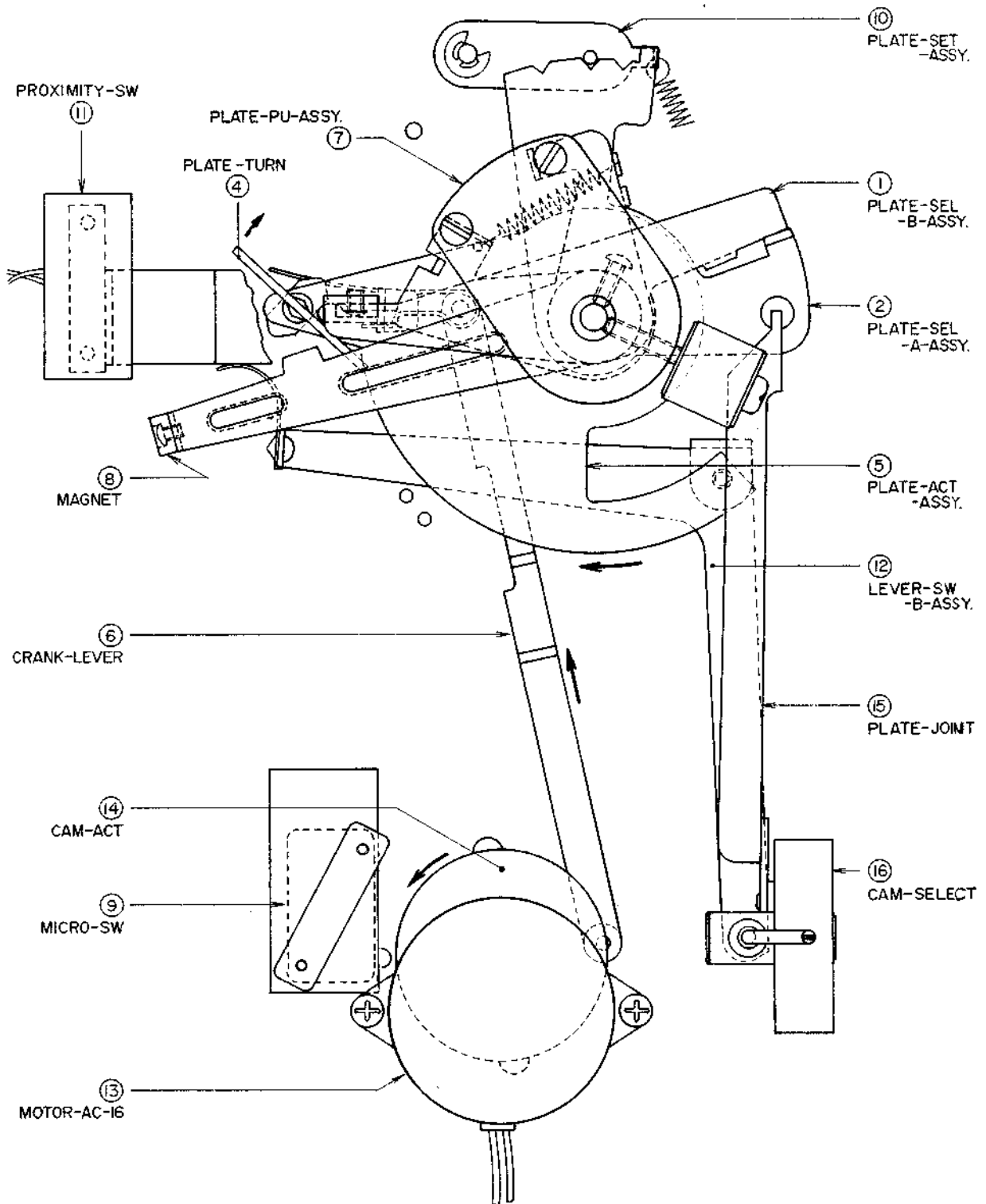

Fig. 5 Lead in condition (PU Arm at 25 cm of record outer circumference).

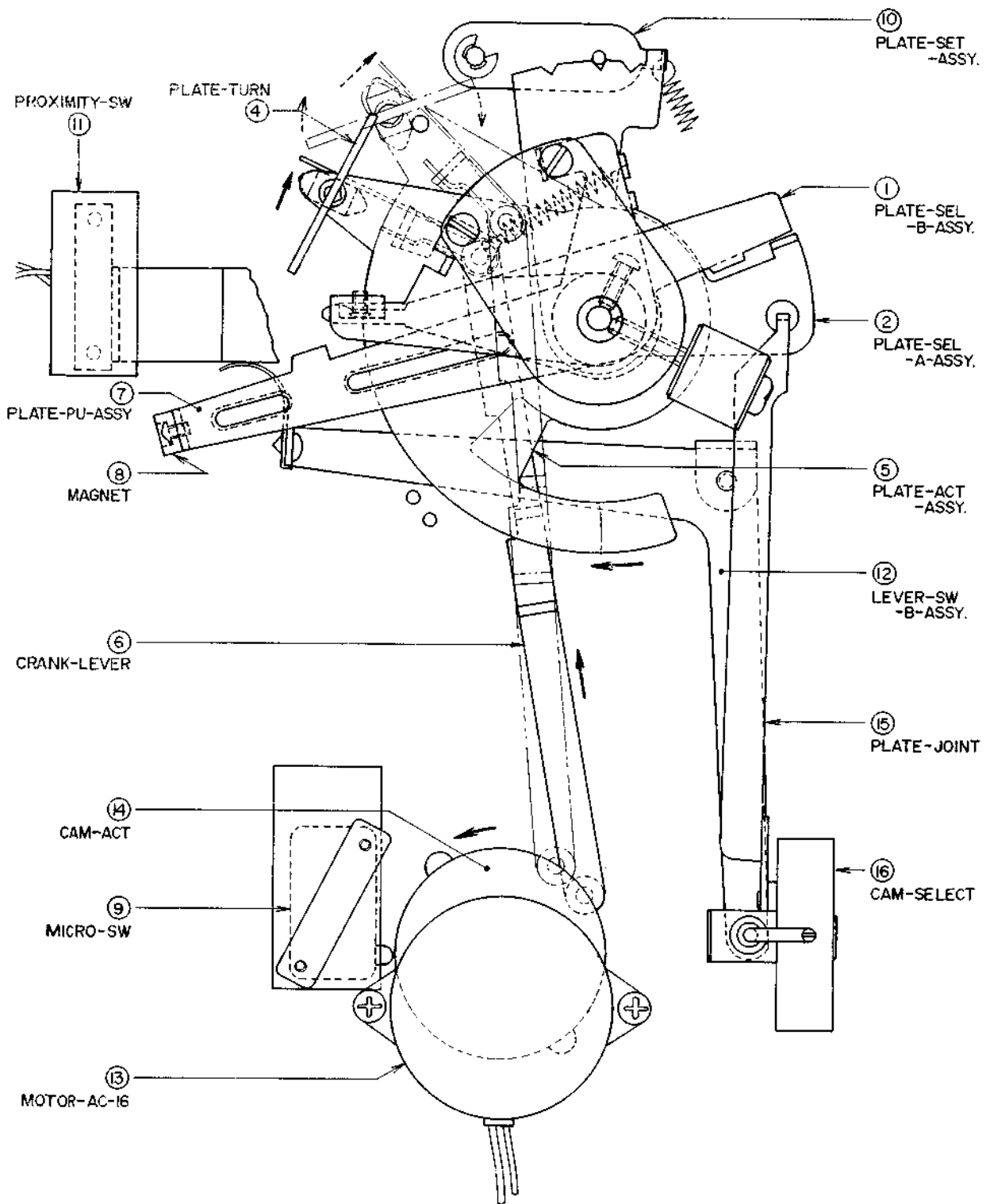

Fig. 6 Lead in condition (PU Arm starting to set down at 25 cm of record outer circumference).

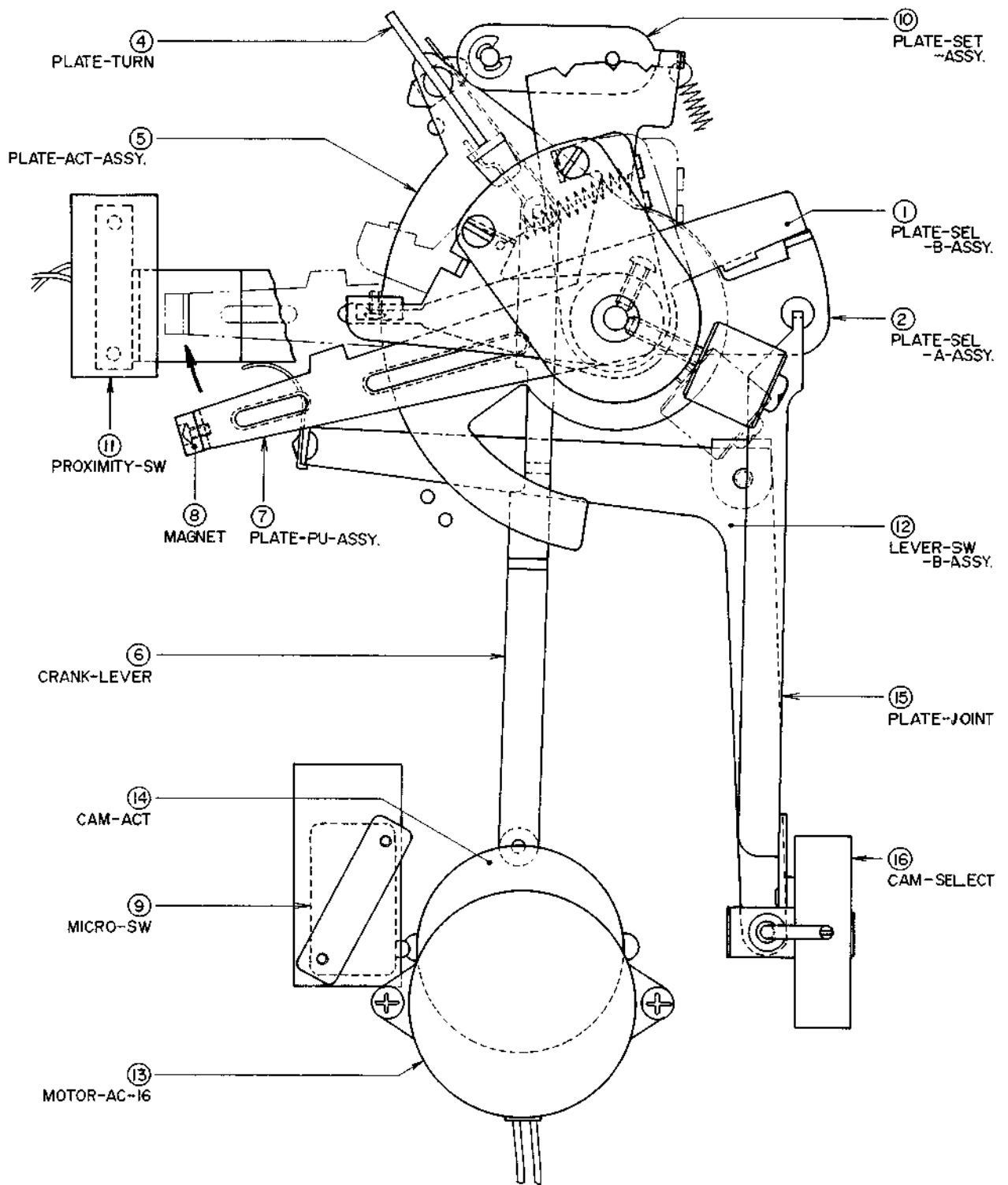

Fig. 7 Lead in complete (performance condition).

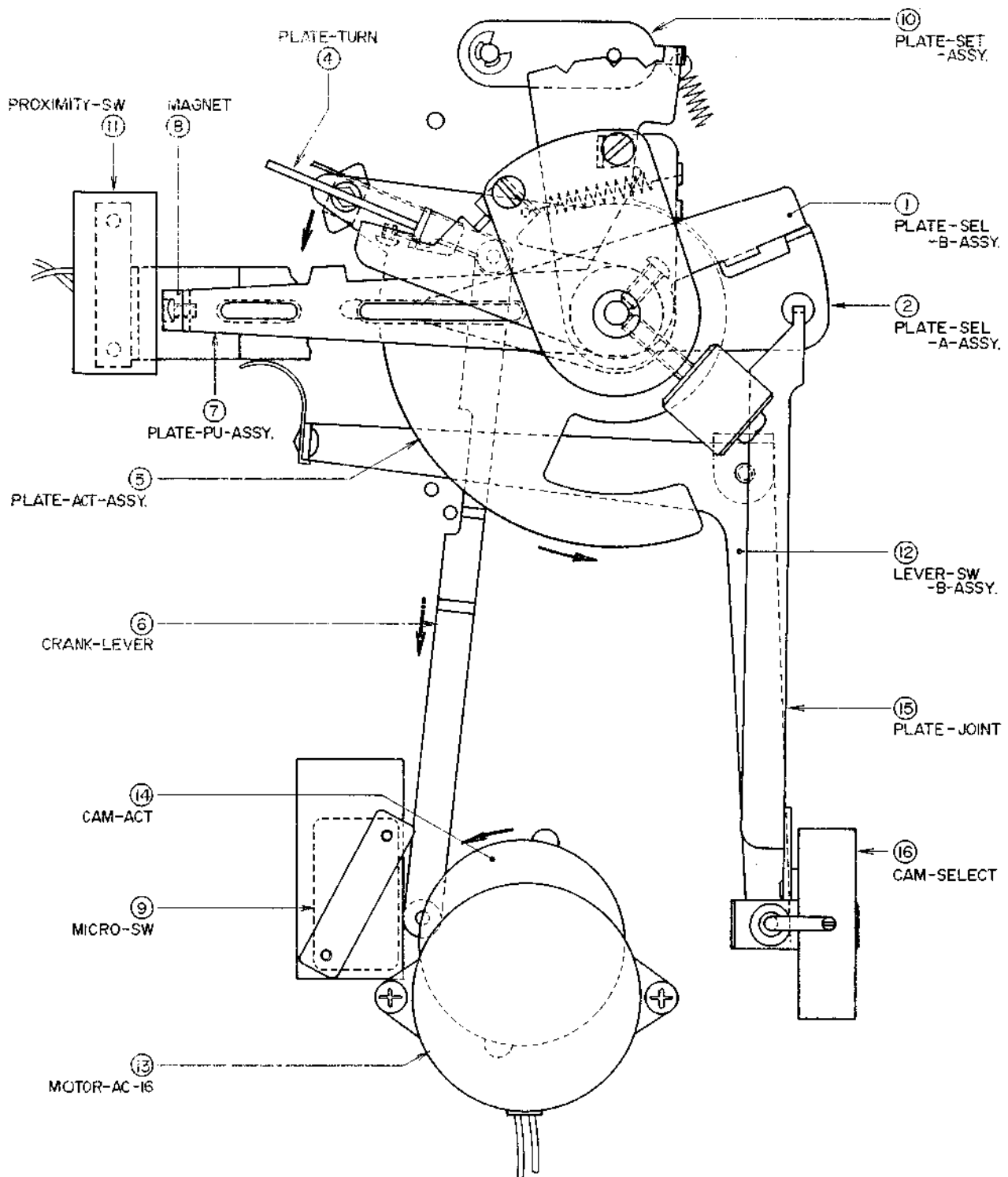

Fig. 8 Lead out condition (PU Arm ascends at 25 cm lead out groove)

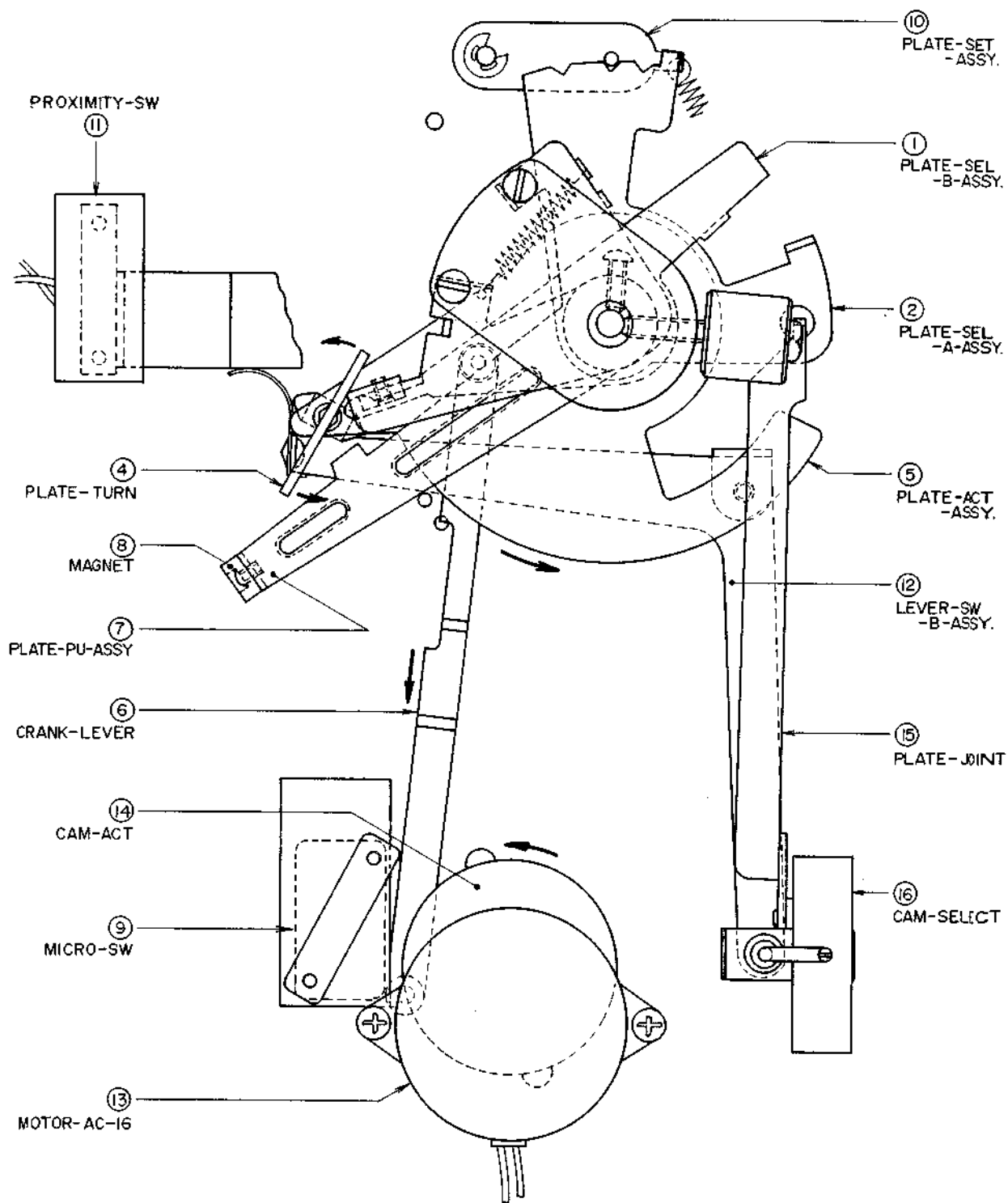

Fig. 9 Lead out condition (PU Arm returns to its 1).

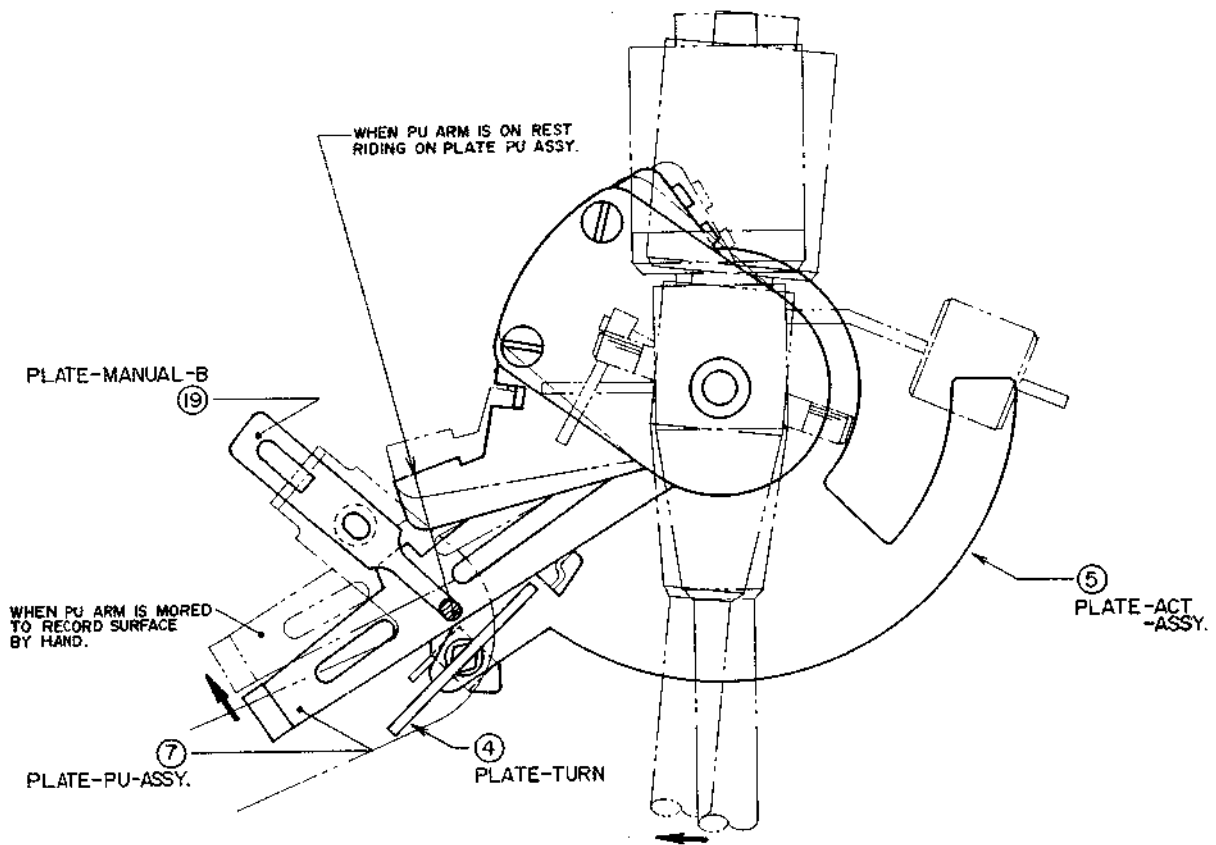

Fig. 10 When operated manually

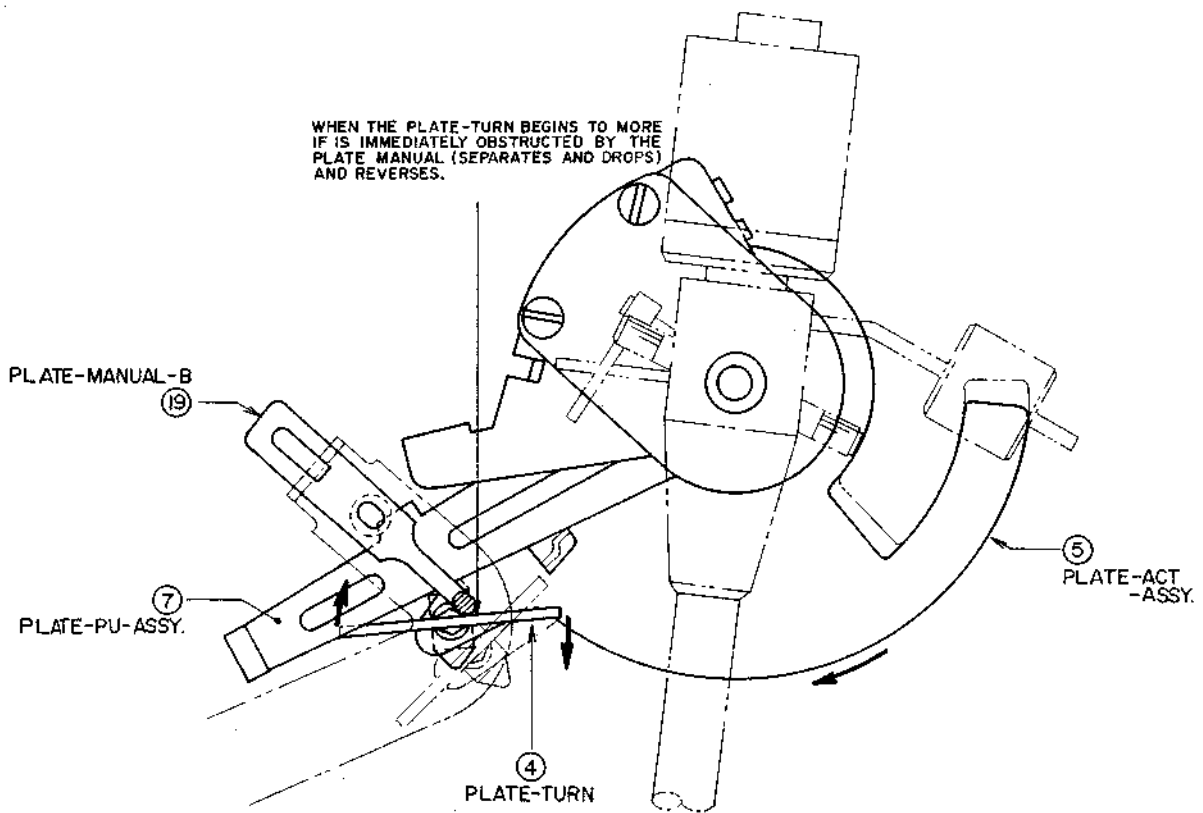

Fig. 11 Manual operation begins

IV. VARIOUS ADJUSTMENTS

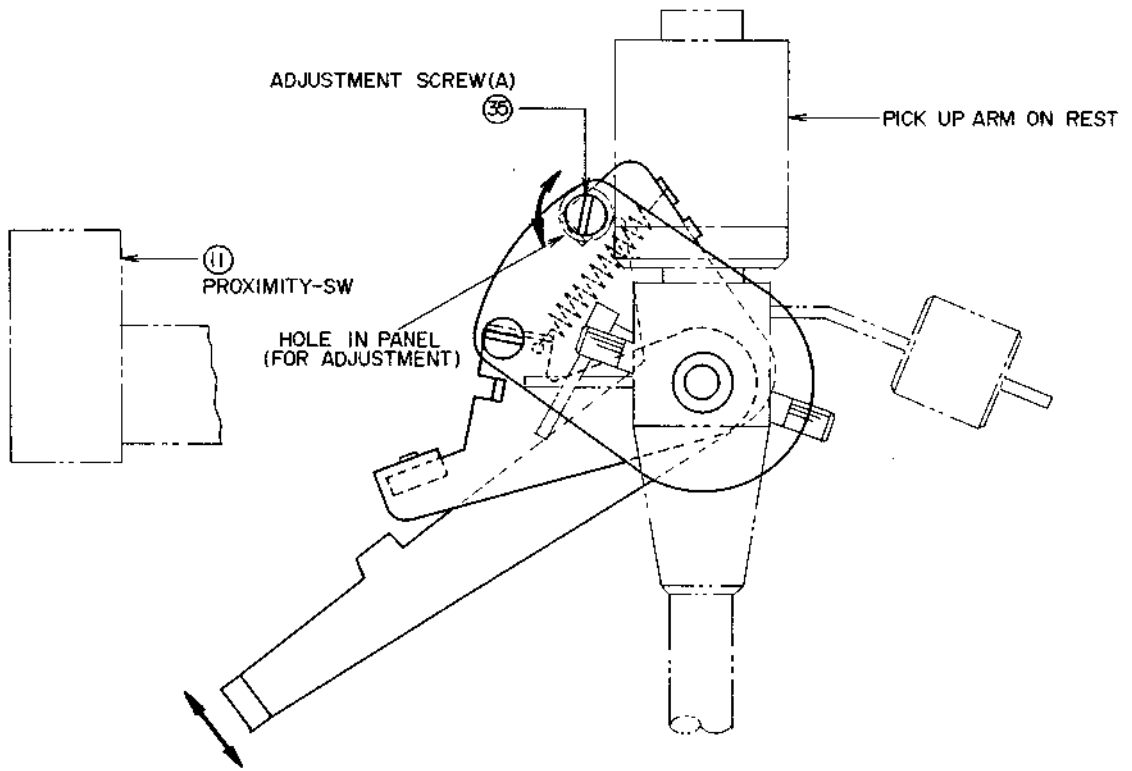

Fig. 12

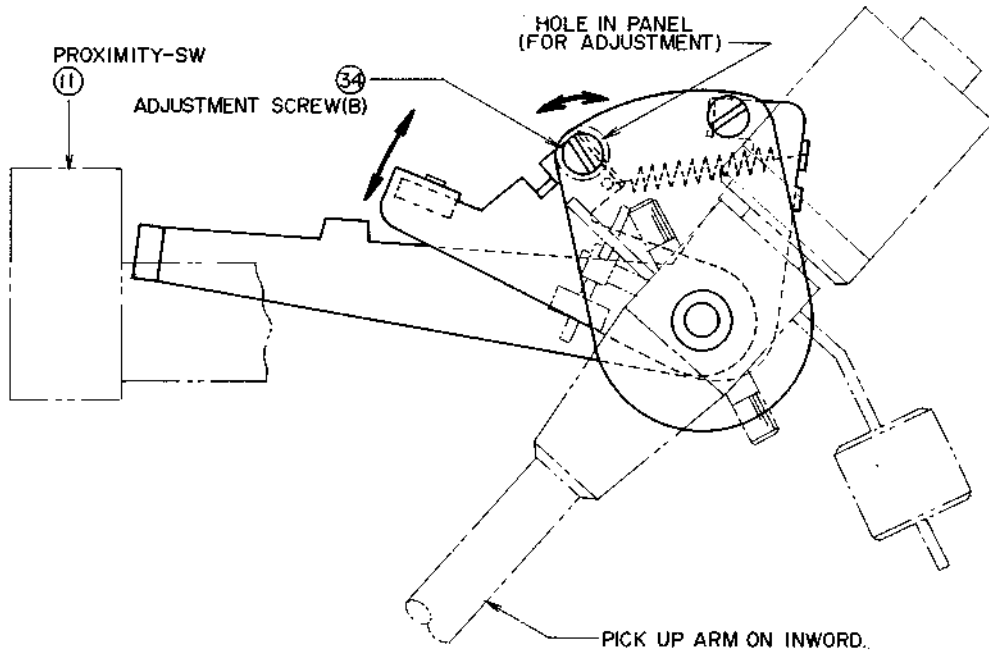

Fig. 13

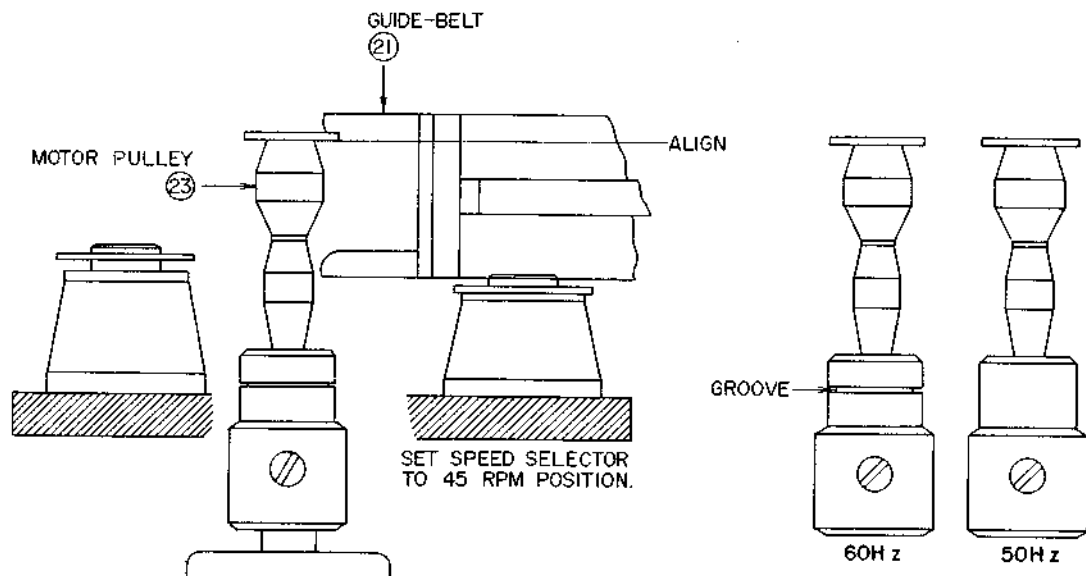

Fig. 14

All of the stationary parts of this machine are ideally adjusted prior to shipment. However, the following adjustments are necessary according to circumstances involving usage.

(1) LEAD OUT POSITION

Stationary the pick-up arm on arm rest and remove the rubber plug on panel toward the rear part of the pick up arm, when adjustment screw (A) (Fig. 12) is turned to the right through the hole in panel with a (-) screw driver, lead out will be sooner and when turned to the left, lead out will be delayed.

That is to say;

For adjusting toward outer circumference, turn adjustment screw (A) to the right, and for adjusting toward inner circumference, turn adjustment screw (A) to the left.

After adjustment, be sure to replace rubber plug.

NOTE: When using the standard accessory cartridge, adjust so that on a JIS 30 cm, 25 cm record, operation begins between 115ϕ and 109ϕ , and on a 17 cm record operation begins between 106ϕ and 98ϕ from the center spindle.

* When the adjustment screw is turned 1 revolution, the position of the pick up arm stylus tip is changed by about 2 mm.

(2) LEAD IN POSITION

Remove the rubber plug on panel toward rear part of pick up arm and place pick up arm at inner position (about where lead out begins)

When adjustment screw (B) (Fig. 13) is turned to the right through the hole in panel with a (-) screw driver, adjustment is to further inner position, and when turned to the left, adjustment is to further outer position.

That is to say;

For adjustment toward outer circumference, turn adjustment screw (B) to the left, and for adjustment toward inner circumference, turn adjustment screw (B) to the right.

After adjustment, be sure to replace rubber plug.

NOTE: When using the standard accessory cartridge, adjust so that on a JIS 30 cm, record, touch down (lead in) takes place between 298ϕ and 293ϕ , and on a 25 cm record, lead in takes place between 247ϕ and 242ϕ and on a 17 cm record lead in takes place between 173ϕ to 168ϕ .

In the case of a record of which the dimensions are outside of JIS specifications and the lead in (touch down) position is off by a considerable margin, rather than supplementing the distance with the adjustment screw, apply manual operation.

* When the adjustment screw is turned one revolution, the position of the pick up arm stylus tip is changed by about 2 mm.

(3) CYCLE CHANGE

(MOTOR PULLEY REPLACEMENT)

Cycle change is effected by changing the motor pulley. 50 and 60 Hz differentiation can be determined by the groove on the 60 Hz pulley (See Fig. 14). While viewing horizontally as shown in the figure, install so that the lower part of the motor pulley brim and the lower part of the guide belt are lined up. (Refer to figure) (Set speed selector to 45 r.p.m. position)

When the turntable rotates, if a rumbling noise from the belt can be heard, (except while switching) and operation is not smooth, further adjust pulley height by moving up and down slightly and position for best adjustment.

V. PLAYER CARE

1. LIFE OF NEEDLE (STYLUS TIP)

The lifetime of needle is about 500 hrs. of use (both sides of about 500 30 cm LP record). If the needle becomes old, because the record will be damaged and tone quality will become inferior, be sure to replace as soon as is needed. The needle will wear especially fast and the record surface will be scratched if records on which dust is allowed to accumulate are played. Therefore, please be sure to keep record clean by wiping and cleaning the record grooves with water soaked gauze. Also if dust adheres to the turntable mat as this will cause the record to become dirty easily, the mat should also be kept clean.

2. NEEDLE CHANGE

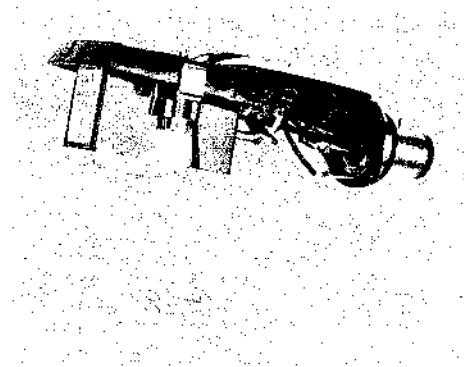

When replacing needle, use only one of the replacement types listed below.

APN-2

APN-4

M-91ED (SHURE)

3. LUBRICATION

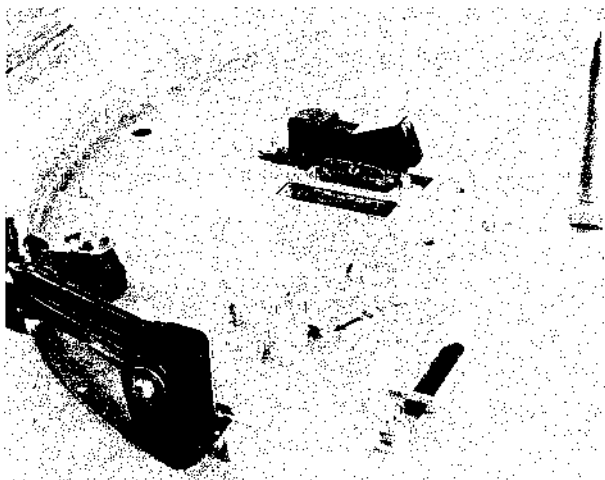

Because for rotating parts and parts which rub together during operation, oilless metal and the best grease is used, your machine will not need lubrication for some time. Oil at points shown in illustration about once per year using standard accessory player oil. In case you have run out of standard accessory oil, use #60 spindle oil or a high grade machine oil. If used continually for business purposes, etc., oil about once or twice per month.

CAUTION: Following lubrication, because oil will adhere to the drive belt and pulley and to the turntable etc., wipe the oil off of these parts with a cloth to which a little carbon tetrachloride or thinner (benzine can be also be used) has been applied.

VI. BLOCK DIAGRAM

1. Models AP-420, AP-004 (A)

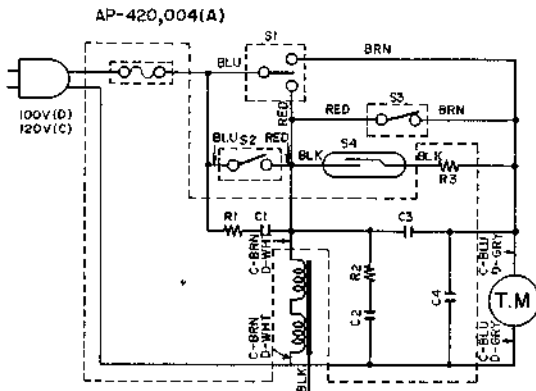
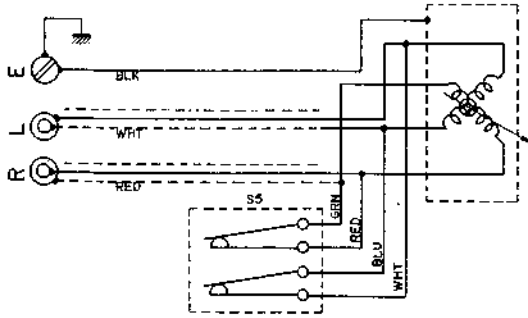
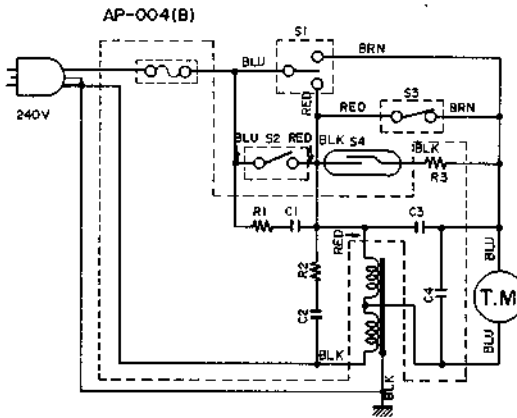
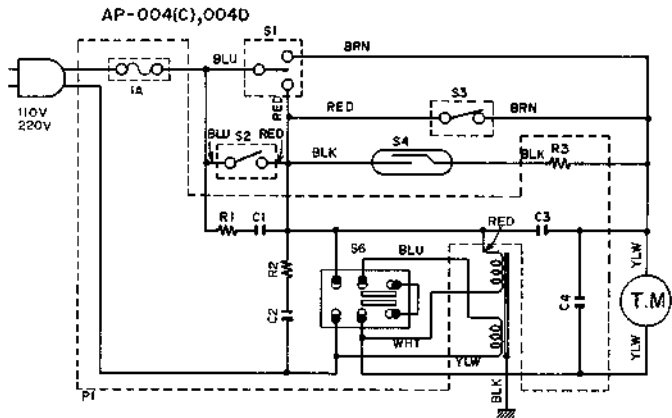

Fig. 15

2. Models AP-004 (B), (C), AP-004D



- NOTE
- R1 : RC-1/2-22-K
 - R2 : R. CEMENT-2-12
 - R3 : RC-1/2-330-K
 - C1 : COO.033-1500-B
 - C2 : COO.22-1000-B
 - C3 : CK-0.0022-M-1400
 - C4 : CMM-0.047-M1000D

Fig. 16

3. P.C. BOARD

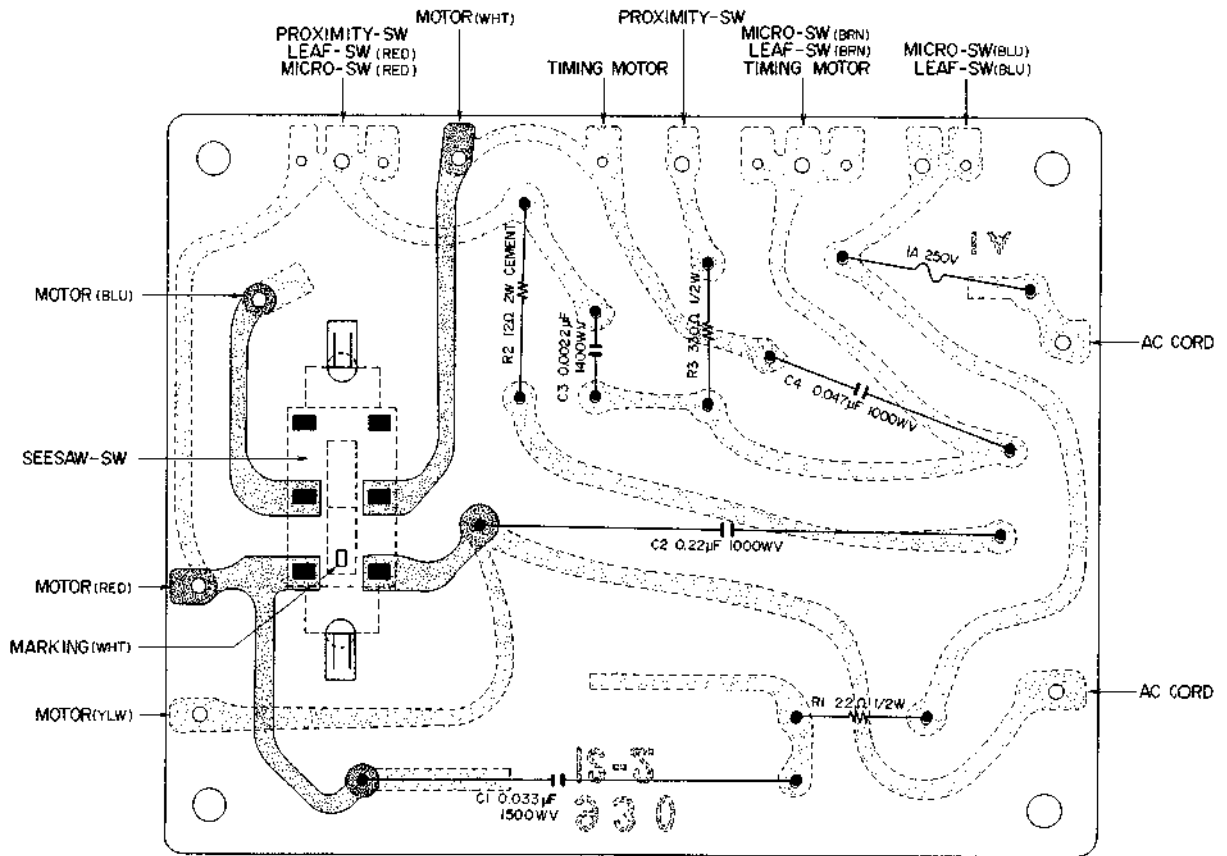

AP-004 (A) Fig. 17

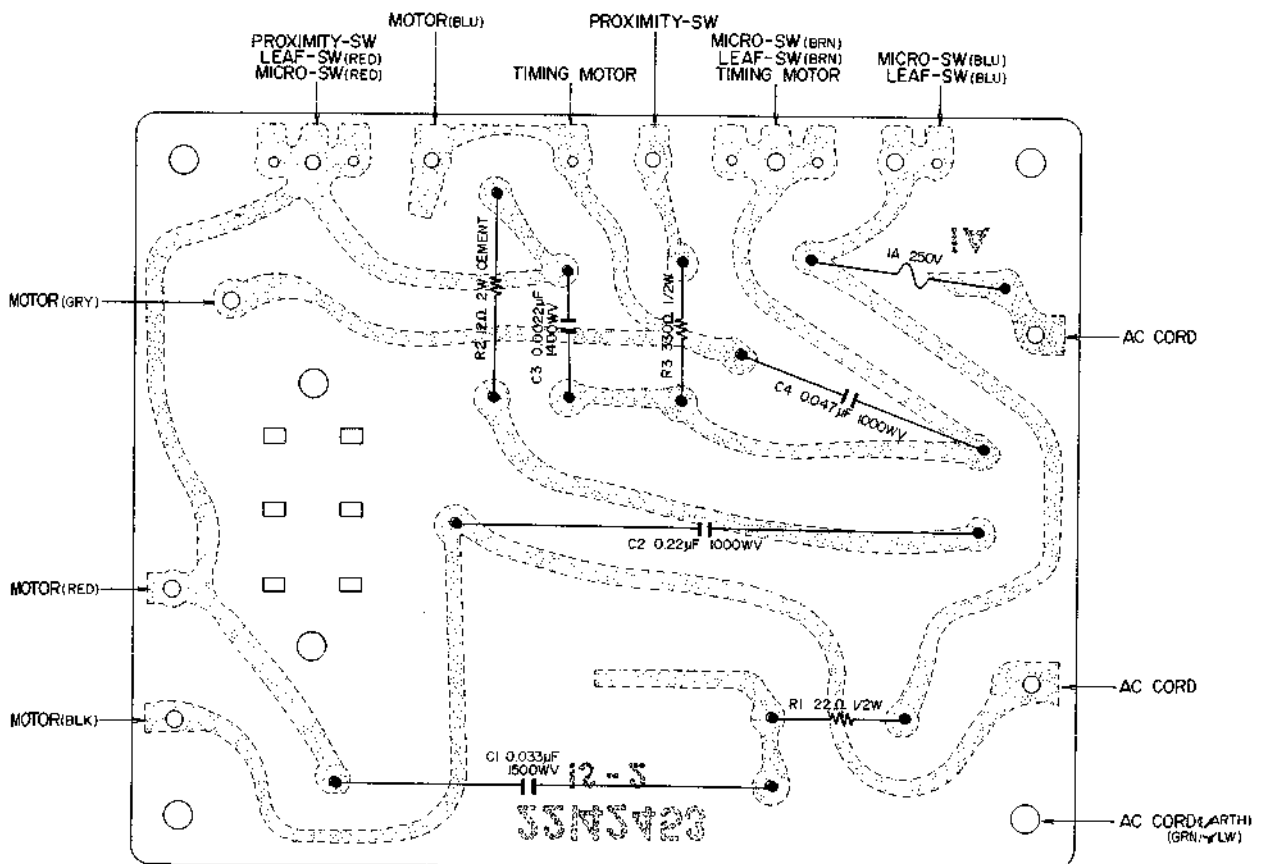

AP-004 (B) Fig. 18

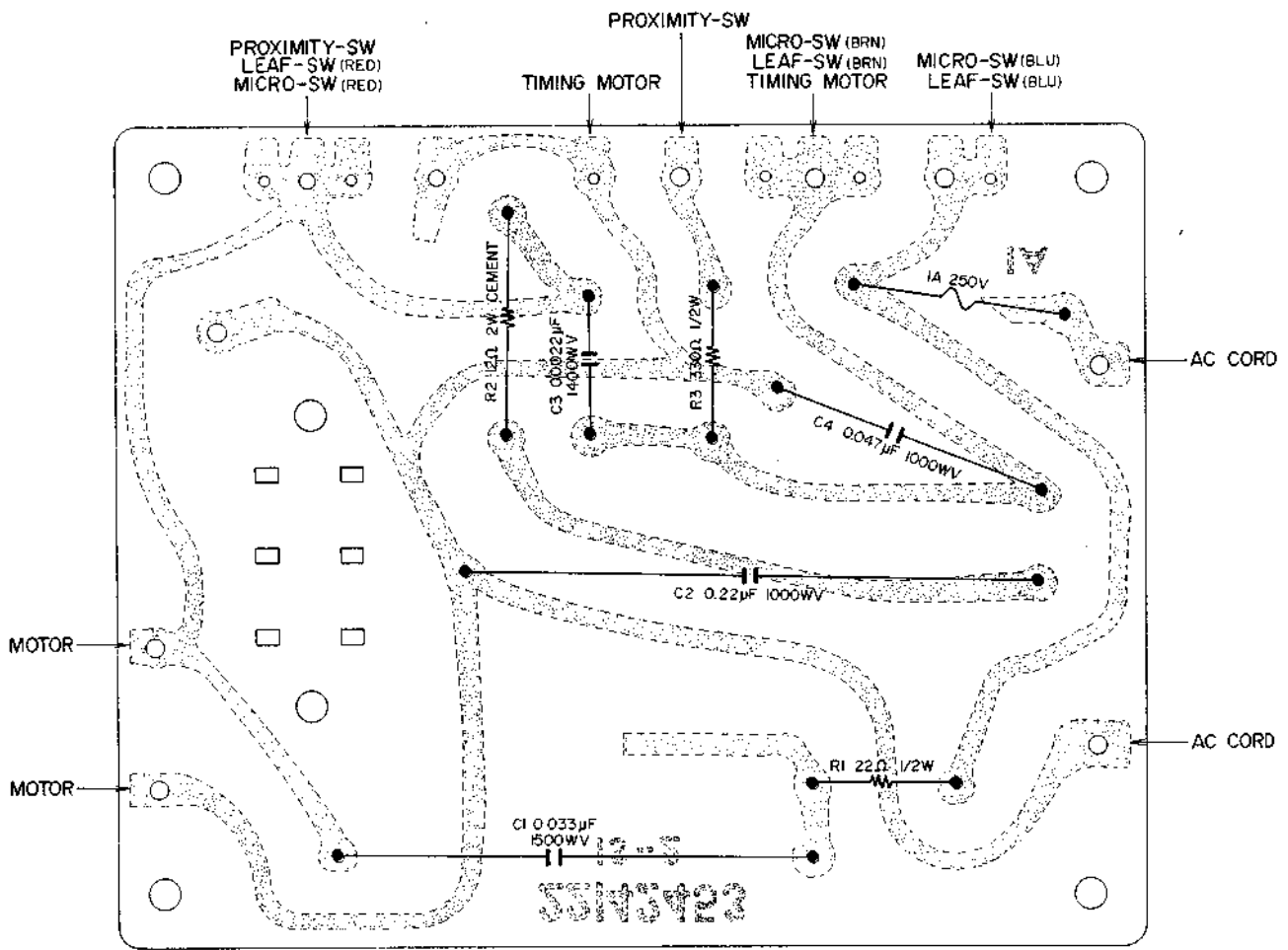

AP-004 (C) Fig. 19

VII. ADJUSTMENT CHART

CONDITION	EXPLANATION	SOURCE & SYMPTOM	COUNTERMEASURE
Poor tone quality	1. Distortion (When using new quality record)	Faulty cartridge Distortion persists after changing needle and confirming normal pick-up arm operation (Amp. Speaker normal)	Replace cartridge
		Worn needle Crackling sound ever when playing new record. Especially vague at high range.	Replace needle
		Stylus pressure inadequate Needle sinks too far into cartridge body during record playback. (too much pressure). Sound generally distorted and needle protrudes. (too little pressure)	Readjust stylus Pressure
		Bent stylus A crunching sound exists and the level of right and left differs greatly. Also loss in directional sensitivity.	Replace stylus
		Dust adhering to stylus tip Sound is vague or distortion exists.	Clean stylus tip
	2. Hum Noise	Lead wire from pick-up and power source wiring is too close together. Hum is altered by changing position of lead wire. Insufficiently grounded When pick-up arm or player body is touched with your hand, hum noise increases. No sound from one side (or both channels) and only a hum is emitted.	Check wiring and correct Check Ground wire side of amp. input from cartridge. Ground player with amp. Plug in pin plug cord perfectly.
	3. Left/right sound separation poor (2 channel) Front/rear sound separation poor (4 channel)	Faulty Cartridge Using a monaural record, left/right sound scatters and is not emitted from the center. (2 ch check) Confirm that the ⊕ ⊖ terminals are not reversed on one side at cartridge output pin and shell pin connection. (Amp. and Speaker connections are correct)	Replace cartridge
	4. Distortion at one channel only	Bent pick-up head Observe head during record performance Pick-up arm rotating shaft faulty Check pick-up arm side pressure. At zero balance, arm does not move smoothly by means of inside force canceller. Installation of PLATE-PU-ASSY unsatisfactory Pick-up arm heavy or catches when moved to left and right by hand.	Replace pick-up arm Replace pick-up arm Correct installation height as specified
	5. No sound	Pin plug cord is disconnected or solder has come off of lead wire connection. Confirm connections with tester. Shorted wire inside cartridge Check cartridge terminal D.C. resistance with tester. (L ch, R ch) Muting Switch defective (SW-LEAF 20) Switch installation faulty. Misshapen	Correct Replace cartridge Correct installation Replace Switch

CONDITION	EXPLANATION	SOURCE & SYMPTOM	COUNTERMEASURE
Unusual Noise	1. Mechanical noise (direct noise)	Automatic mechanism needs oil, or foreign matter adhering to these parts Check oil Is metal rubbing against metal at contact points? Check for scorch Noise from motor vibration Noise from low speed motor. (MOTOR AC-16 (13)) Contact of GUIDE BELT (21) and BELT (22) Relative height of MOTOR PULLEY (23) and GUIDE BELT poor. Noise and Vibration interference from motor (MOTOR AC-4 (24)) During Motor rotation if table mount or arm is touched with your hand, vibration is evident. Direct rotating noise is audible. MOTOR PULLEY (23) misshapen During revolutions, check MOTOR PULLEY vibration and eccentricity.	Clean and oil rotating parts and parts which sub together during operation. Replace Motor Adjust MOTOR PULLEY height Adjust motor installation Replace Motor Replace MOTOR-PULLEY
	2. Electrical Noise (from speaker)	Lead wire leak or pin plug cord connection faulty Sometimes shock noise and hum is emitted. Interference when lead wire is touched. No noise periodically Check with tester Defective Cartridge Interference when upper part of shell is lightly tapped. Defective Muting Switch (SW-LEAF (20)) A rough scratching noise is emitted immediately prior to and immediately following record performance (Faulty switch contact point) Rumbling noise from motor (MOTOR-AC-4 (24)) rotation vibration During motor revolutions, vibration occurs when player mount table and arm is touched with your hand. (Confirm that shipping screws have been removed.)	Correct lead wire wiring Make proper pin plug cord connection. Replace cartridge Clean contact point Correct installation Replace switch Adjust motor installation. Replace CUSHION-RB-MD (25) Replace Motor
Turntable does not rotate (or rotation is unstable)	1. Electrical circuit problem	Fuse blown Check P.C. Board fuse with tester. Lead wire open or solder has come loose. Check with tester according to schematic diagram. Defective switch (SW-LEAF (17)) Is installation loose or is it misshapen? Check lead-through with tester.	Replace with proper fuse (1A) Correct wiring Install property Replace SW-LEAF (17)
	2. Motor out of order (MOTOR-AC-4 (24))	Coil-open or shorted wire Check coil lead-through with tester Rotor shaft needs oil or shaft is being caught by something. Rotate rotor by hand and check.	Replace motor Clean around rotating shaft and oil.
	3. Table shaft out of order	TABLE-SHAFT (26) and TABLE-BEARING (27) defective When turntable is rotated by hand, it seems heavy. There is a noise as soon as turntable is stopped. Too much rattle. (Remove belt and check) Needs oil Irregular noise when turntable is rotated by hand.	Replace table shaft bearing. Lubricate with specified oil. Replacement

CONDITION	EXPLANATION	SOURCE AND SYMPTOM	COUNTERMEASURE
	4. Speed change mechanism defective	BELT (22) and MOTOR PULLEY (23) TURN-TABLE (28) slipping Dust or oil adhering to BELT, MOTOR PULLEY, TURNTABLE. Relative positions of BELT (22) and MOTOR PULLEY (23) GUIDE BELT (21) poor. Belt rubbing noise. Belt does not come to specified position (drum-like part) of MOTOR PULLEY. Speed change is not smooth.	Clean with benzine or alcohol. If belt is inferior replace. Adjust MOTOR-PULLEY height. Adjust adjustment nut (29)
	5. Revolutions too slow slow or uneven. (Check to make sure Item 4 has been adjusted)	Inferior BELT (22) Is contact side of belt inferior? Discolored or misshapen? Check for belt stretch.	Replace Belt
Automatic mechanism does not function.	1. Does not Lead in (Check arm rest clamp to see whether it has come off).	Fuse blown (Turntable also does not rotate) Check P.C. Board Fuse with tester. Broken lead wire or improperly soldered Check according to schematic diagram Defective Switch (SW-LEAF (17)) Is installation loose? Is it misshapen? Low speed motor defective (MOTOR-AC-16 (13)) Check lead-through with tester (open wire, short). Does vibration occur when the motor is touched with your hand, but does not rotate? (internal damage) CAM-ACT (14) installation screw loose. Low speed motor rotates but CAM-ACT does not move at all. LEVER-CRANK (6) defective Low speed motor and CAM-ACT vibrate, but are stopped. Lever crank has dropped, bent and contacting another part. TORSION-SPRING (30) has come off. Confirm that PLATE-TURN is rotating 90° each time. Relativity of Arm Rest and lifter height poor (REST-PU-ASSY (32)) When the PU Arm moves from rest to lifter, the lifter is very high and the tubular part of the arm does not ride on the arm rest. Manual lifter out of order Manual lifter knob can be brought DOWN, but stylus tip does not lower. (horizontal motion only) No resistance when lifter knob is set to UP side. Lifter shaft needs oil or dust adhering to this part Stiff motion when arm is lowered (catches while lowering) Relativity of PLATE-MANUAL-B (19) and PU-PLATE-ASSY (7) poor When PU arm is on arm rest, MANUAL-PLATE-B separates from PLATE-PU-ASSY and drops.	Replace with proper type fuse. (1A) Repair lead wire. Correct installation. Replace Switch SW-LEAF (17) Replace low speed motor (MOTOR-AC-16 (13)). Tighten installation screw. Straighten LEVER CRANK bend or replace. Install TORSION SPRING properly. Lower BAR LIFTER (31) height to optimum level with holding screw. Replace lifter assembly. Clean and oil lifter shaft Replace PU Arm Re-install PLATE-PU-ASSY to specified position

CONDITION	EXPLANATION	SOURCE & SYMPTOM	COUNTERMEASURE
	2. Does not lead out (cut)	<p>* Lead in is normal.</p> <p>* Record is equivalent to JIS specifications. PLATE-PU-ASSY (7) is not installed according to specifications.</p> <p>When arm is brought gently to record level by hand, lead out operation begins.</p> <p>PROXIMITY-SWITCH (11) and MAGNET (8) relativity amok.</p> <p>When PU Arm is brought inward, switch and magnet moves around horizontally, and there is a gap of about 1 to 2 mm.</p> <p>Defective PROXIMITY-SWITCH (11)</p> <p>Magnet position suitable, but does not operate when knob is brought to CUT position lead out operation begins normally.</p> <p>Relativity of Arm Rest and REST-PU-ASSY (32) poor.</p> <p>When the PU-ARM returns to rest from lifter, lifter is very low and the tubular part of the arm does not ride on the arm rest.</p>	<p>Re-install PLATE-PU-ASSY to specified position</p> <p>Straighten bend in part of PLATE-PU-ASSY on which magnet is installed.</p> <p>Repair PROXIMITY-SWITCH installation part.</p> <p>Replace PROXIMITY-SW (11).</p> <p>Raise BAR LIFTER (31) height to optimum level with holding screw.</p>
	3. Operates continuously. (Lead-in, lead out)	<p>MICRO SWITCH (9) defective</p> <p>Has cut knob slipped to REPEAT position? Confirm whether or not SW-LEAF (17) is perfectly installed.</p> <p>Lead wire shorted</p> <p>Check with tester according to schematic diagram.</p> <p>When cut knob is set to START CUT, there is no return, or return is faulty.</p> <p>CAM-START (18) operation is not smooth.</p> <p>Plate spring (SPRING-P-CAM (33)) misshapen or loosely installed.</p>	<p>Replace MICRO SWITCH.</p> <p>Repair wiring.</p> <p>Grease CAM-START.</p> <p>Tighten plate spring or replace.</p>
	4. Automatic operation is not smooth, or stops during operation (lead in-lead out)	<p>Automatic mechanism needs oil.</p> <p>No grease at slanted part of PLATE-ACT-ASSY (5).</p> <p>Stiff motion when arm is lowered (catches while lowering).</p> <p>MICRO-SWITCH (9) improperly installed</p> <p>When cut knob is brought to REPEAT or START CUT position, operation takes place, but when brought to center position, operation immediately stops.</p> <p>Insufficient low speed motor (MOTOR-AC-16 (13)) torque.</p> <p>Check to see if there is sufficient grease on CAM-START (14) surface.</p>	<p>Lubricate</p> <p>Replace PU-ARM.</p> <p>Re-install micro switch to specified position (Securely tighten installation screw)</p> <p>Lubricate</p> <p>Replace MOTOR-AC-16 (13).</p>
	5. Lead-In position amok (JIS equiv. record)	<p>Improper cartridge installation.</p> <p>Check to see whether PU Arm LOCK-NUT is loose. Check to see if cartridge is in center of shell.</p> <p>Does cartridge slant when on record?</p> <p>PLATE-PU-ASSY (7) installation loose.</p> <p>Check PLATE-PU-ASSY by hand.</p> <p>PU Arm defective</p> <p>Check loose play of PU Arm bearing part.</p> <p>Faulty adjustment (When within 2 to 3 mm)</p> <p>Adjustment Screw (Special Screw (34)), (Confirm with Selector knob at 30 and using a 30 cm record)</p>	<p>Correct installation.</p> <p>Tighten holding screw.</p> <p>If too much loose play (rattle), replace PU Arm.</p> <p>Correct to proper position.</p>

CONDITION	EXPLANATION	SOURCE & SYMPTOM	COUNTERMEASURE
	<p>6. Lead-Out position amok (JIS equiv. record).</p>	<p>Improper cartridge installation. Check to see whether PU Arm Lock Nut is loose. Check to see if cartridge is in center of shell. Does cartridge slant when on record. PLATE-PU-ASSY (7) installation loose. Check PLATE-PU-ASSY by hand. PU Arm defective Check loose play of PU Arm bearing part. Relativity of PROXIMITY SWITCH (11) AND MAGNET (8) amok. When PU ARM is brought inward, switch and magnet moves around horizontally, and there is a gap of about 2 to 2.5 mm. PROXIMITY SWITCH installation arm operation faulty PROXIMITY SWITCH does not operate when Selector knob is set to 17 ↔ 25. When installation is moved by hands it is heavy, catches, or does not move. LEVER-SW-B ASSY (12) operation faulty PROXIMITY SWITCH installation arm operates smoothly, but switch does not operate when Selector knob is set to 17 ↔ 25, or operation is faulty. Check CAM-SELECT (16) for lack of oil. Faulty adjustment (When within 2 to 3 mm) Adjustment Screw (SPECIAL SCREW (35)) (Confirm with Selector at 30 and using a 30 cm record, and then with Selector at 17 using a 17 cm record).</p>	<p>Correct installation.</p> <p>Tighten holding screw.</p> <p>If too much loose play (rattle), replace PU Arm. Straighten bend in part of PLATE-PU-ASSY on which magnet is installed. Repair PROXIMITY SWITCH installation part. Lubricate installation arm and prop point with a small amount of oil</p> <p>Replace automatic mechanism. Straighten bend in LEVER-SW-B ASSY or replace. Lubricate CAM-SELECT.</p> <p>Correct to proper position.</p>
	<p>7. Does not repeat (Lead-in operates normally)</p>	<p>SW-LEAF (17), faulty contact, broken wire With cut knob set to REPEAT, check lead through between switch terminals with tester. Check to see whether the soldes has come off where the lead wire is connected to the switch terminal. Also check for broken lead wire. Cut knob cannot be set to REPEAT. CAM is being suppressed. Branch Spring (SPRING-P-CAM (33)) misshapen, or installation is imperfect.</p>	<p>Check with tester. Confirm that SW-LEAF installation is tight.</p> <p>Repair branch. Spring installation (tighten). Replace Branch Spring (SPRING-P-CAM)</p>
	<p>8. Cannot manually manipulate</p>	<p>Installation position of PLATE-PU-ASSY incorrect Check whether or not PLATE-MANUAL-B (19) separates from PLATE-PU-ASSY and drops when PU Arm is moved to the vicinity of the outer circumference of a 30 cm record. PLATE MANUAL B (19) does not operate smoothly. PLATE-MANUAL-B catches. PLATE-MANUAL-A (36) misshapen or improperly installed.</p>	<p>Correct to specified installation position.</p> <p>Correct installation. Replace MANUAL-PLATE-ASSY.</p>

CONDITION	EXPLANATION	SOURCE & SYMPTOM	COUNTERMEASURE
Operation of Manual Lifter faulty (at record performance)	1. Lifter does not work either when set to "UP" or "DOWN" position.	Adjustment faulty Adjustment Screws (37) and (38) are not working effectively. PLATE-L1 (39) bent or misshapen Check visually. PLATE-L1 (39) installation loose SPRING-P-B (41) misshapen or loose installation Check visually. Installation Screw (42) loose.	Adjust Repair or replace. Tighten to Specified position. Replace SPRING P-B. Tighten installation screw.
	2. Lifter does not work when set to "DOWN" position.	CYLINDER (43) insufficient oil. Inferior. Lift out LIFTER ASSY and check. NOTE: FROM THE STANDPOINT OF THE OIL FILTER, IF LIFTER IS LEFT AT UP POSITION FOR AN EXTENDED PERIOD OR TIME, WHEN IT IS FIRST BROUGHT TO DOWN POSITION, OPERATION IS COMPARATIVELY SLOW (STOPS TEMPORARILY), BUT THIS DOES NOT MEAN THAT IT IS OUT OF ORDER.	Replace LIFTER ASSY
	3. When Lifter is manipulated UP, DOWN it does not conform. (springs back at up position)	Ball Bearing (BEARING-1/8 (31)) inside CAM LIFT (44) Lift out LIFTER-ASSY and check.	Dismantle and insert ball bearing. Replace LIFTER-ASSY.

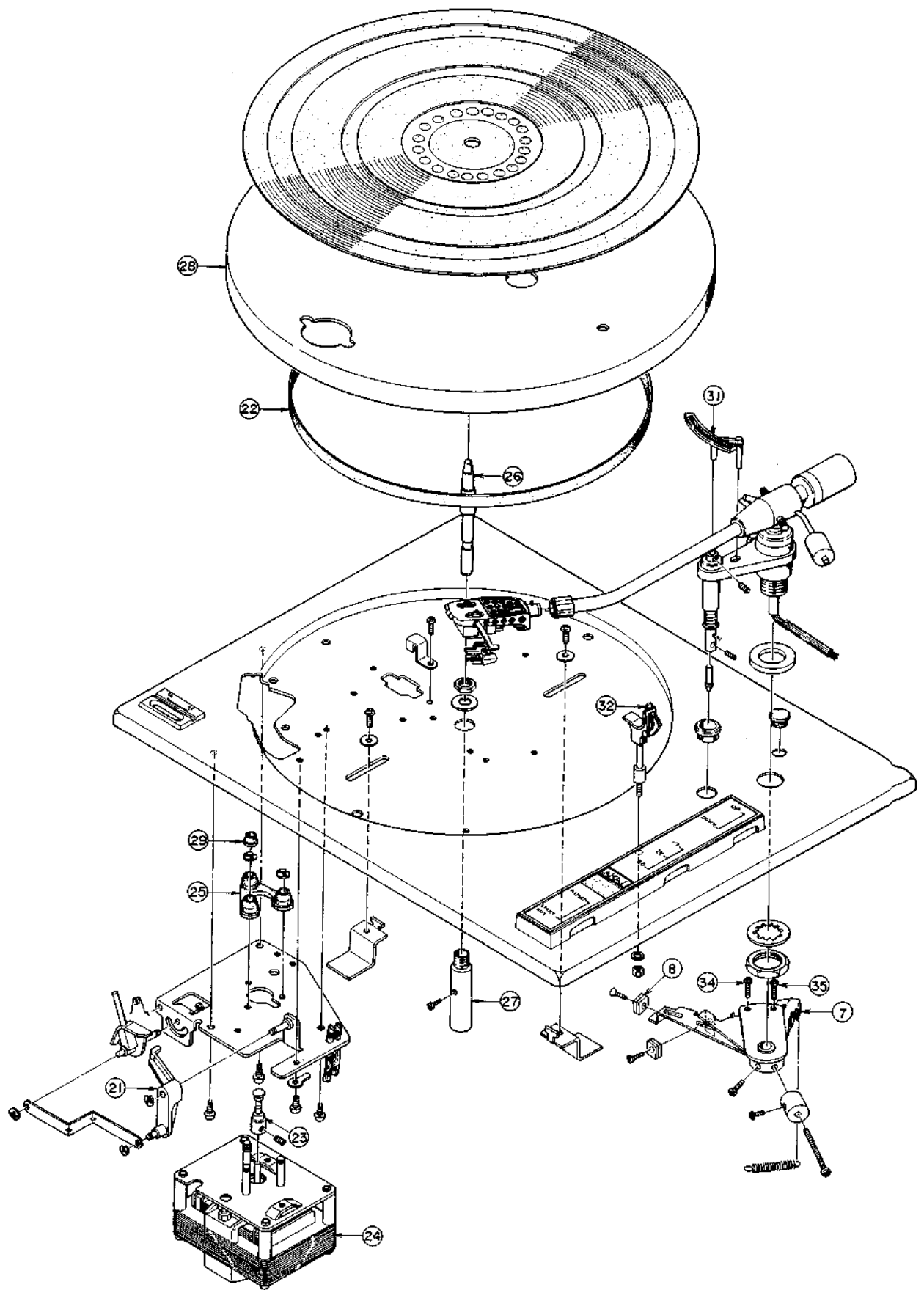

Fig. 20

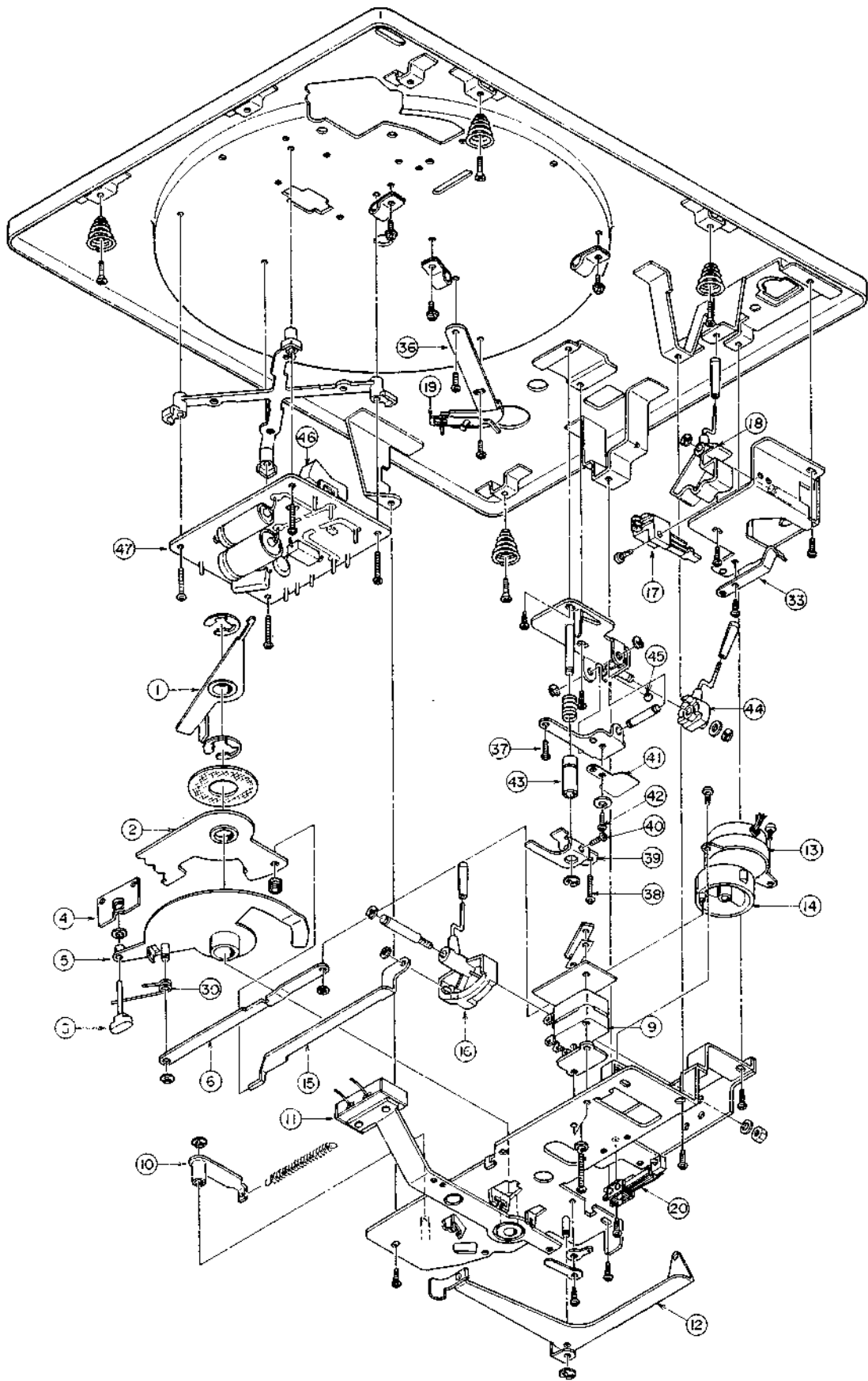

Fig. 21

SECTION 2

PARTS LIST

TABLE OF CONTENTS

FIG. 1	ASSEMBLY BLOCK (1)	34
FIG. 2	ASSEMBLY BLOCK (2)	37
FIG. 3	CASE BLOCK	38
INDEX		39

HOW TO USE THIS PARTS LIST

1. This parts list is compiled by various individual blocks based on assembly process.
2. When ordering parts, please describe parts number, serial number, and model number in detail.
3. How to read List

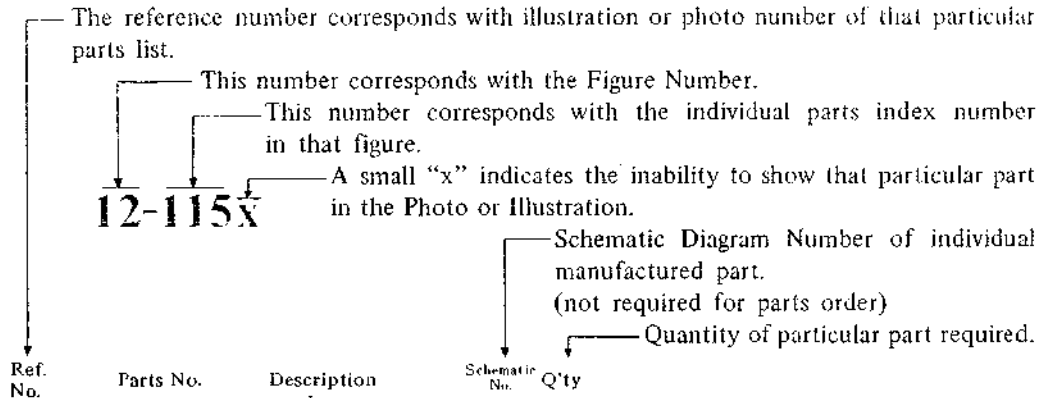

Ref. No.	Parts No.	Description	Schematic No.	Qty
FLYWHEEL BLOCK #13				
12-115x	800425	Flywheel Block Assy. Comp. RDG #13		1
12-116	244506	Flywheel Only	RD-233	1
12-117x	244754	Felt, Flywheel	RD-275	1
12-118	251324	Main Metal Case	RD-236	1
12-119	253080	Main Metal	RD-237	1

4. The symbol numbers shown on the P.C. Board list can be matched with the Composite Views of Components of the Schematic Diagram or Service Manual.
5. The indications of Resistors and Capacitors in the photos of P.C. Board are being eliminated.
6. The shape of the parts and parts name, etc. can be confirmed by comparing them with the parts shown on the Electrical Parts Table of P.C. Board.
7. Both the kind of part and installation position can be determined by the Parts Number. To determine where a parts number is listed, utilize Parts Index at end of Parts List.
It is necessary first of all to find the Parts Number. This can be accomplished by using the Reference Number listed at right of parts number in the Parts Index. (meaning of ref. no. outlined in Item 3 above).
8. Utilize separate "Price List for Parts" to determine unit price. The most simple method of finding parts Price is to utilize the reference number.

ELECTRICAL PARTS TABLE

<p>Because the indication of resistors and capacitors in the P.C. Board photos are being eliminated, please confirm parts name and shape by comparing them with the parts shown in this table.</p>	<p style="text-align: center;">1</p>  <p style="text-align: center;">Solid Resistor</p>	<p style="text-align: center;">2</p> <p style="text-align: right;">Stopper Type</p>  <p style="text-align: center;">Insulator Type</p> <p style="text-align: center;">Carbon Resistor</p>	<p style="text-align: center;">3</p>  <p style="text-align: center;">Metal Oxide Film Resistor</p>
<p style="text-align: center;">4</p>  <p style="text-align: center;">Cement Resistor</p>	<p style="text-align: center;">5</p>  <p style="text-align: center;">Wire-Wound Resistor</p>	<p style="text-align: center;">6</p>  <p style="text-align: center;">Thermistor</p>	<p style="text-align: center;">7</p>  <p style="text-align: center;">Enamel Resistor</p>
<p style="text-align: center;">1</p>  <p style="text-align: center;">MP Capacitor (Tubular Type)</p>	<p style="text-align: center;">2</p>  <p style="text-align: center;">Plastic Capacitor</p>	<p style="text-align: center;">3</p>  <p style="text-align: center;">Mylar Capacitor</p>	<p style="text-align: center;">4</p>  <p style="text-align: center;">VFM (Hi-Q) Capacitor</p>
<p style="text-align: center;">5</p>  <p style="text-align: center;">Mylar Capacitor</p>	<p style="text-align: center;">6</p>  <p style="text-align: center;">Tantalum Capacitor</p>	<p style="text-align: center;">7</p>  <p style="text-align: center;">Oil Capacitor (Tubular Type)</p>	<p style="text-align: center;">8</p> <p style="text-align: right;">Vertical Type</p> <p style="text-align: center;">Tubular Type</p>  <p style="text-align: center;">Styrol Capacitor</p>
<p style="text-align: center;">9</p>  <p style="text-align: center;">Electrolytic Capacitor (Tubular Type)</p>	<p style="text-align: center;">10</p> <p style="text-align: right;">Vertical Type</p> <p style="text-align: center;">Tubular Type</p>  <p style="text-align: center;">Electrolytic Capacitor</p>	<p style="text-align: center;">11</p>  <p style="text-align: center;">Ceramic Capacitor</p>	<p style="text-align: center;">12</p>  <p style="text-align: center;">Metalized Mylar (Paper) Capacitor</p>
<p style="text-align: center;">13</p>  <p style="text-align: center;">Air Condenser</p>		<p style="text-align: center;">VR</p>  <p style="text-align: center;">Semi-Fixed Volume</p>	
<p style="text-align: center;">L</p>  <p style="text-align: center;">Ferri Inductor</p>	<p style="text-align: center;">TR</p>  <p style="text-align: center;">Transistor</p>		
<p style="text-align: center;">CR</p>  <p style="text-align: center;">Spark Quencher</p>	<p style="text-align: center;">D</p>  <p style="text-align: center;">Diode (Silicon, Zener, Germanium)</p>		

ASSEMBLY BLOCK (1)

Ref. No.	Parts No.	Description	Schematic No.	Q'ty	Ref. No.	Parts No.	Description	Schematic No.	Q'ty
PU ARM BLOCK									
1-1	PL711461	PU Arm Comp.	2073170300	1	1-62	ZS463296	ISO Screw, pan head 4x8	2088176800	2
1-2	PL711494	Lifter Bar Comp.		1	1-63	PL710021	Rubber Cap	2077977900	1
1-3	PL711505	Base Stand	2074379500	1	1-64	PL710032	Control Base	2077978000	1
1-4	PL711516	Special Nut 16M		1	1-65	PL710043	Control Name Plate	2079181700	1
1-5	PL711527	Special Washer 16M		1	1-66x	PL710076	Washer (SPC) D3.2x11x0.5t		2
1-6	PL711538	Shank Pin	2076372800	1	1-67x	ZS710087	Tapping Screw #2 3x10 (pan)		2
1-7	PL711573	Head Shell		1	1-68	PL710054	Bush	2077384000	1
1-8	PL711617	Special Screw 2.6x11		2	1-69x	PL710280	Panel Spring A	2070379800	2
1-9x	PL717445	Special Screw 2.6x13		2	1-70x	PL710291	Panel Spring B (Left Front)	2070379900	1
1-10x	ZW711652	Special Washer (Nylon) D2.6		2	1-71x	PL710302	Panel Spring C (Right Rear)	2070380000	1
1-11x	ZW711641	Special Nut 2.6M		2	1-72x	PL710324	Tapping Screw #2 3x12 (countersunk)	2270153400	4
1-12	PL711663	PU Rest Comp.	2073866600	1	1-73	PL710313	Switch Plate	2002174000	1
1-13	ZW710638	Spring Washer 4M		1	1-74	ZS552611	ISO Screw, pan head 3x8 (Black)		3
1-14	ZW710640	Nut 4M		1	1-75x	PL710010	Screen	2074380200	1
SPEED CHANGE DEVICE BLOCK									
1-15	PL710098	Sub Panel	2074379300	1	1-76x	PL711540	Main Weight		1
1-16	BM711674	Motor AC-4-A (110/220)	2212540400	1	1-77x	PL711551	Sub Weight		1
1-17x	BM712102	Motor AC-4-B (240)	2212540500	1	1-78x	PL711562	Lateral Weight		1
1-18x	BM712113	Motor AC-4-C (120)	2214540600	1					
1-19x	BM710166	Motor AC-4-D (100)	2214540700	1					
1-20	PL710100	Motor Base, w/prop	2074379200	1					
1-21	PL710144	Spacer AL-P	2077377000	4					
1-22	PL710111	Adjust Nut D4	2079668100	1					
1-23	ZS710234	ISO Screw, pan head 4x45		4					
1-24	ZS270123	'E' Ring 4M	6-1-9	2					
1-25	PL710155	Motor Cushion Rubber	2088178700	1					
1-26	PL710122	Belt Guide	2074682100	1					
1-27	PL710201	Speed Cam	2075768300	1					
1-28	PL710212	Return Spring	2070774000	1					
1-29	PL710133	Connector Plate	2075387500	1					
1-30	PL710245	Push Nut CS-D3		2					
1-31	ZW358018	'E' Ring 2M	6-1-9	1					
1-32	ZW270101	'E' Ring 3M	6-1-9	2					
1-33	ZS463353	Tapping Screw #2 3x8 (BR)		5					
1-34	PL710357	Belt	2072861500	1					
1-35	PL710177	Motor Pulley (50 Hz)	2071672000	1					
1-36x	PL710188	Motor Pulley (60 Hz)	2071672100	1					
PU PLATE BLOCK									
1-37	PL710706	PU Plate Comp.	2075175000	1					
1-38	PL710717	Magnet	2210204100	1					
1-39	ZS481691	ISO Screw, binding head 2.6x4		1					
1-40	PL711797	Magnet	2210203800	1					
1-41	ZS711821	ISO Screw, countersunk head 2.6x8		1					
1-42	PL710730	Pull Spring	2070561100	1					
1-43	PL710752	Special Screw 3x10	2079590500	1					
1-44	PL710796	Special Screw 3x12	2079587900	1					
1-45	PL710728	Weight	2078171500	1					
1-46	ZS710763	ISO Screw, pan head 2.6x8		1					
1-47	ZS552611	ISO Screw, pan head 3x8		1					
1-48	ZS710774	ISO Screw, pan head 4x30		1					
1-49x	PL710785	Scotch Sheet	2074378800	1					
1-50x	PL717456	Sheet H	2079197700	1					
TURN TABLE BLOCK									
1-51	PL710368	Turn Table	2072366700	1					
1-52	PL710370	Turn Table Sheet	2072366800	1					
1-53	PL710425	Table Shaft	2072567200	1					
1-54	PL710381	Table Bearing	2072563700	1					
1-55	PL710392	Special Screw	2079563000	1					
1-56	PL710403	Washer (SPC) D10.1x17x0.8t	2079194500	1					
1-57	PL710414	Special Nut 10M	2079667500	1					
PANEL BLOCK									
1-58	PL710008	Panel	2071376100	1					
1-59x	PL717467	Panel (420)	2071377200	1					
1-60	PL710256	Washer (SPC) D4.2x11x0.8t	2079164900	2					
1-61	PL710267	Lock Plate	2074379100	2					

When ordering parts, please describe Parts Number, Serial Number, and Model Number in detail.

FIG. 1 ILLUSTRATION OF ASSEMBLY BLOCK (1)

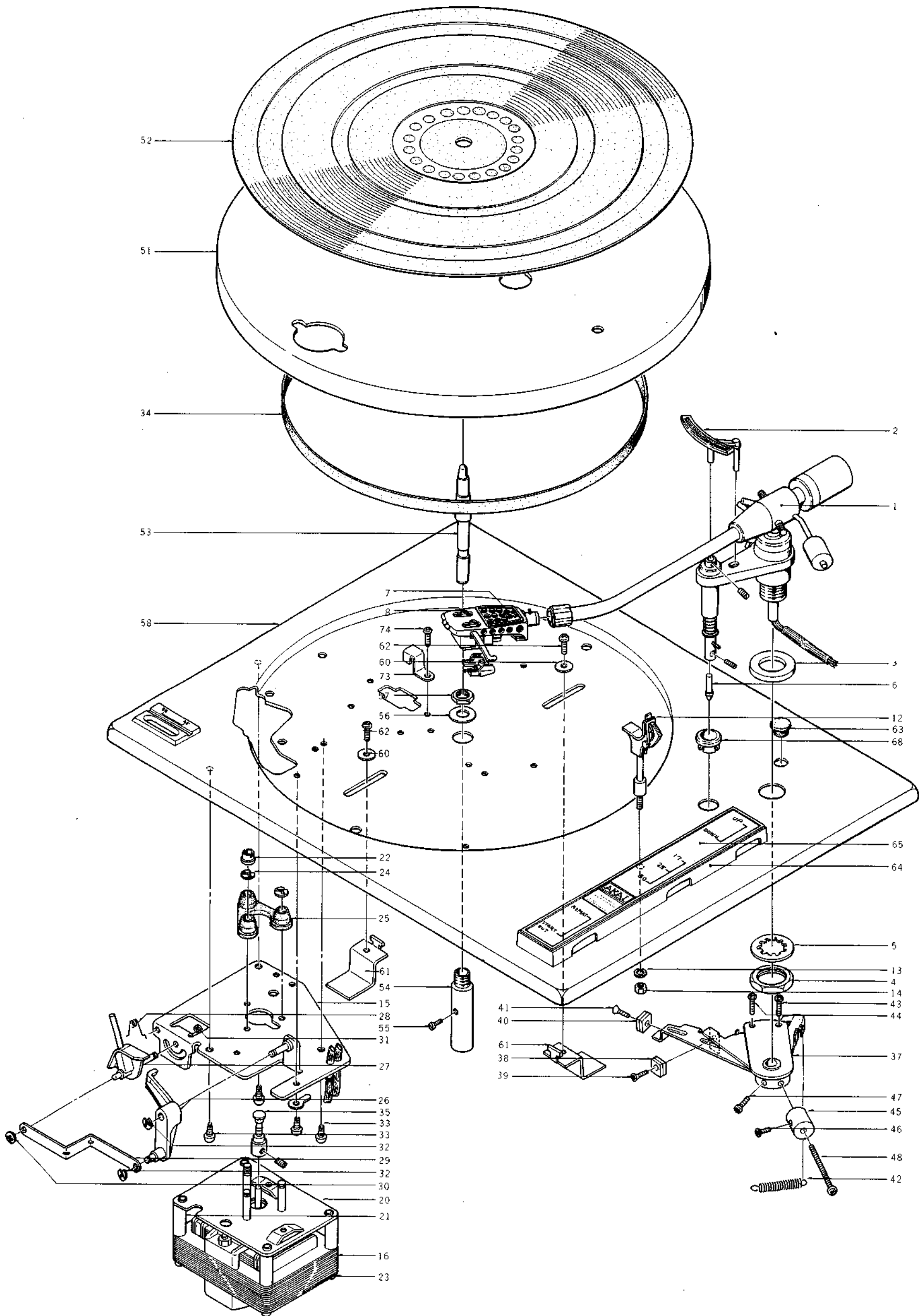
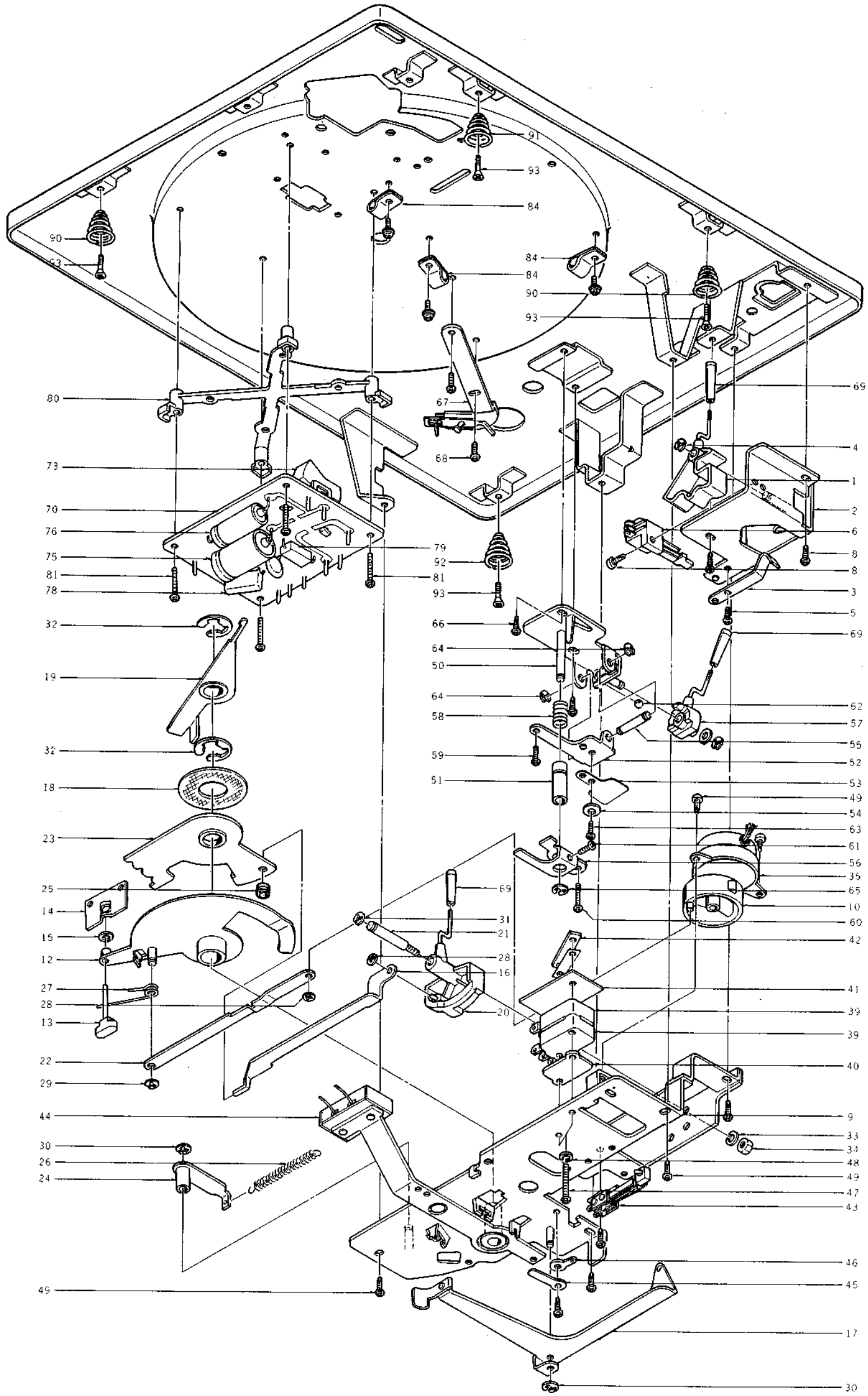

FIG. 2 ILLUSTRATION OF ASSEMBLY BLOCK (2)



ASSEMBLY BLOCK (2)

Ref. No.	Parts No.	Description	Schematic No.	Q'ty
START CAM BLOCK				
2-1	PL710673	Start Cam	2075768200	1
2-2	PL710684	Cam Holder Comp.	2074682000	1
2-3	PL710695	Start Cam Spring	2070964700	1
2-4	ZW270123	'E' Ring 4M	6-1-9	1
2-5	ZS447772	Tapping Screw #2 3x6 (BR)		1
2-6	ES711764	Leaf Switch	2214632700	1
2-7x	PL711775	Barrier (120)	2274855200	1
2-8	ZS463353	Tapping Screw #2 3x8 (BR)		3
AUTOMATIC MECH. BLOCK				
2-9	PL710436	Chassis Comp.	2074173600	1
2-10	PL710460	Cam Act	2075768700	1
2-11x	ZS463353	Tapping Screw #2 3x8 (BR)		4
2-12	PL710482	Plate Act Comp.	2075176100	1
2-13	PL710493	Return Shaft	2076379900	1
2-14	PL710504	Return Plate	2075388600	1
2-15	PL710515	Washer (NY) D2.5x6x0.3t	2079160900	1
2-16	PL710526	Joint Plate	2075388000	1
2-17	PL710537	Lever SW. B Comp.	2075176500	1
2-18	ZW717478	Washer (Fiber) D4.1x12x0.5t	2079261400	1
2-19	PL710548	Plate Select B Comp.	2075178300	1
2-20	PL710550	Select Cam	2075768400	1
2-21	PL710561	Cam Shaft A	2076468300	1
2-22	PL710572	Crank Lever	2075377100	1
2-23	PL710583	Plate Select A Comp.	2075176200	1
2-24	PL710594	Plate Set Comp.	2075176400	1
2-25	PL710447	Bush R	2088166600	1
2-26	PL710458	Pull Spring	2070567200	1
2-27	PL710605	Torsion Spring	2070768600	1
2-28	PL710245	Push Nut CS-D3		3
2-29	ZW358018	'E' Ring 2M	6-1-9	1
2-30	ZW270101	'E' Ring 3M	6-1-9	3
2-31	ZW270123	'E' Ring 4M	6-1-9	1
2-32	ZW710627	'E' Ring 10M		2
2-33	ZW710638	Spring Washer 4M		1
2-34	ZW710640	Nut 4M		1
2-35	BM711685	Timing Motor AC-16 (110/220)	2212540800	1
2-36x	BM711696	Timing Motor AC-16 (240)	2212541000	1
2-37x	BM711707	Timing Motor AC-16 (120)	2212541100	1
2-38x	BM712383	Timing Motor AC-16 (100)	2212541200	1
2-39	ES711718	Micro Switch	2214642600	2
2-40	PL711720	Sheet (Small)	2074376900	1
2-41	PL711731	Sheet (Large)	2074376800	1
2-42	PL711742	Special Nut	2079668000	1
2-43	PL711753	Muting Switch (Leaf)	2214633100	1
2-44	PL711786	Lead Switch	2214632200	1
2-45	PL711977	Lead Clamper D3	2218413800	1
2-46	PL711988	Lug 3M		1
2-47	ZS711810	ISO Screw, pan head 3x30		2
2-48	ZW712080	Spring Washer 3M		2
2-49	ZS463353	Tapping Screw #2 3x8 (BR)		5

Ref. No.	Parts No.	Description	Schematic No.	Q'ty
HAND-OPERATE LIFTER BLOCK				
2-50	PL710807	Lifter Bracket Comp.	2073562400	1
2-51	PL710818	Sylinder	2088561800	1
2-52	PL710842	Seesaw Plate	2074678000	1
2-53	PL710853	Plate Spring B	2070965400	1
2-54	PL710256	Washer (SPC) D4.2x11x0.8t	2079164900	1
2-55	PL710864	Seesaw Shaft	2076388300	1
2-56	PL710875	Lifter Plate	2074677900	1
2-57	PL710886	Lifter Cam	2075768500	1
2-58	PL710897	Compression Coil Spring	2277164400	1
2-59	ZS710763	ISO Screw, pan head 2.6x8		1
2-60	ZS710908	ISO Screw, pan head 2.6x14		1
2-61	ZS710910	ISO Screw, pan head 3x8 (cup)		1
2-62	PL710921	Steel Ball 1/8"		1
2-63	ZS710943	Tapping Screw #2 3x5 (pan)		1
2-64	ZW358018	'E' Ring 2M	6-1-9	2
2-65	ZW270101	'E' Ring 3M	6-1-9	3
2-66	ZS447772	Tapping Screw #2 3x6 (BR)		2
2-67	PL710820	Manual Plate Comp.	2075174900	1
2-68	ZS463353	Tapping Screw #2 3x8 (BR)		2
2-69	PL710662	Knob	2087185300	3
ELECTRIC PARTS BLOCK				
2-70	PL717480	Auto P.C. Board (110/220) Block Comp.	2214244500	1
2-71x	PL717491	Auto P.C. Board (240) Block Comp.	2214246700	1
2-72x	PL717502	Auto P.C. Board (120, 100) Block Comp.	2214245300	1
2-73	ES712078	Seesaw Switch	2214649400	1
2-74x	EF711966	Fuse 1J-1A-250V	2214422400	1
2-75	EC711933	Oil/C. (E Type) 0.22μF(M) 1000WV		1
2-76	EC711922	Oil/C. (E Type) 0.033μF(M) 1500WV		1
2-77x	EC711944	Ceramic/C. 0.0022μF (M) 1400WV		1
2-78	EC711911	Metalized Polyester/C. 0.047μF(M) 1000WV		1
2-79	ER711900	Cement/R. 2W 12(K)		1
2-80	PL711876	P.C. Board Stay	2074682200	1
2-81	ZS711887	Tapping Screw #2 3x20 (BR)	2079591700	4
2-82x	PL711832	Terminal Plate	2216228700	1
2-83x	ZS710965	Wood Screw, round head 3.1x13		4
2-84	PL712067	Cord Cramp	2218414800	3
2-85x	EW711955	AC Cord (U/L) 2.5M	2217619900	1
2-86x	EW711990	AC Cord (3 core) 2.5M	2217705100	1
2-87x	EW712247	AC Cord (J) 2.5M	2217643600	1
2-88x	PL712001	Cord Stopper (U/L)	2088167600	1
2-89x	PL712012	Cord Stopper (3 core)	2218512600	1
2-90	PL710280	Panel Spring A	2070379800	2
2-91	PL710291	Panel Spring B (Left Front)	2070379900	1
2-92	PL710302	Panel Spring C (Right Rear)	2070380000	1
2-93	PL710324	Tapping Screw #2 3x12 (countersunk)	2270153400	4

When ordering parts, please describe Parts Number, Serial Number, and Model Number in detail.

FIG. 3 PHOTO OF CASE BLOCK



CASE BLOCK

Ref. No.	Parts No.	Description	Schematic No.	Qty
3-1x	PL710954	Cabinet (004)	2081677300	1
3-2x	PL712258	Cabinet (004x)	2084768400	1
3-3	PL712124	Cabinet (420)	2081677600	1
3-4x	PL712282	Cabinet (004D)	2081677500	1
3-5	PL710987	Hinge A	2086164600	2
3-6x	PL711011	Cord Support	2074679000	1
3-7x	PL711022	Cord Support (3 core)	2074682600	1
3-8x	ZS710965	Wood Screw, round head		
			3.1x13	8
3-9x	PL711044	Cushion (Foot)	2086360500	4
3-10	PL710976	Dust Cover	2084766800	1
3-11	PL710998	Hinge B	2075378800	2
3-12	ZS711000	Screw, oval countersunk head		
			4x10	4

When ordering parts, please describe Parts Number, Serial Number, and Model Number in detail.

INDEX

Parts No.	Ref. No.	Parts No.	Ref. No.	Parts No.	Ref. No.	Parts No.	Ref. No.	Parts No.	Ref. No.
BM710166	1-19x	PL710695	2-3	ZS710965	3-8x				
BM711674	1-16	PL710706	1-37	ZS711000	3-12				
BM711685	2-35	PL710717	1-38	ZS711810	2-47				
BM711696	2-36x	PL710728	1-45	ZS711821	1-41				
BM711707	2-37x	PL710730	1-42	ZS711887	2-81				
BM712102	1-17x	PL710752	1-43	ZW270101	1-32				
BM712113	1-18x	PL710785	1-49x	ZW270101	2-30				
BM712383	2-38x	PL710796	1-44	ZW270101	2-65				
EC711911	2-78	PL710807	2-50	ZW270123	1-24				
EC711922	2-76	PL710818	2-51	ZW270123	2-4				
EC711933	2-75	PL710820	2-67	ZW270123	2-31				
EC711944	2-77x	PL710842	2-52	ZW358018	1-31				
EF711966	2-74x	PL710853	2-53	ZW358018	2-29				
EW711900	2-79	PL710864	2-55	ZW358018	2-64				
ES711718	2-39	PL710875	2-56	ZW710627	2-32				
ES711764	2-6	PL710886	2-57	ZW710638	1-13				
ES712078	2-73	PL710897	2-58	ZW710638	2-33				
EW711955	2-85x	PL710921	2-62	ZW710640	1-14				
EW711990	2-86x	PL710954	3-1x	ZW710640	2-34				
EW712247	2-87x	PL710976	3-10	ZW711641	1-11x				
PL710008	1-58	PL710987	3-5	ZW711652	1-10x				
PL710010	1-75x	PL710998	3-11	ZW712080	2-48				
PL710021	1-63	PL711011	3-6x	ZW717478	2-18				
PL710032	1-64	PL711022	3-7x						
PL710043	1-65	PL711044	3-9x						
PL710054	1-68	PL711461	1-1						
PL710076	1-66x	PL711494	1-2						
PL710098	1-15	PL711505	1-3						
PL710100	1-20	PL711516	1-4						
PL710111	1-22	PL711527	1-5						
PL710122	1-26	PL711538	1-6						
PL710133	1-29	PL711540	1-76x						
PL710144	1-21	PL711551	1-77x						
PL710155	1-25	PL711562	1-78x						
PL710177	1-35	PL711573	1-7						
PL710188	1-36x	PL711617	1-8						
PL710201	1-27	PL711663	1-12						
PL710212	1-28	PL711720	2-40						
PL710245	1-30	PL711731	2-41						
PL710245	2-28	PL711742	2-42						
PL710256	1-60	PL711753	2-43						
PL710256	2-54	PL711775	2-7x						
PL710267	1-61	PL711786	2-44						
PL710280	1-69x	PL711797	1-40						
PL710280	2-90	PL711832	2-82x						
PL710291	1-70x	PL711876	2-80						
PL710291	2-91	PL711977	2-45						
PL710302	1-71x	PL711988	2-46						
PL710302	2-92	PL712001	2-88x						
PL710313	1-73	PL712012	2-89x						
PL710324	1-72x	PL712067	2-84						
PL710324	2-93	PL712124	3-3						
PL710357	1-34	PL712258	3-2x						
PL710368	1-51	PL712282	3-4x						
PL710370	1-52	PL717445	1-9x						
PL710381	1-54	PL717456	1-50x						
PL710392	1-55	PL717467	1-59x						
PL710403	1-56	PL717480	2-70						
PL710414	1-57	PL717491	2-71x						
PL710425	1-53	PL717502	2-72x						
PL710436	2-9	ZS447772	2-5						
PL710447	2-25	ZS447772	2-66						
PL710458	2-26	ZS463296	1-62						
PL710460	2-10	ZS463353	1-33						
PL710482	2-12	ZS463353	2-8						
PL710493	2-13	ZS463353	2-11x						
PL710504	2-14	ZS463353	2-49						
PL710515	2-15	ZS463353	2-68						
PL710526	2-16	ZS481691	1-39						
PL710537	2-17	ZS552611	1-47						
PL710548	2-19	ZS552611	1-74						
PL710550	2-20	ZS710087	1-67x						
PL710561	2-21	ZS710234	1-23						
PL710572	2-22	ZS710763	1-46						
PL710583	2-23	ZS710763	2-59						
PL710594	2-24	ZS710774	1-48						
PL710605	2-27	ZS710908	2-60						
PL710662	2-69	ZS710910	2-61						
PL710673	2-1	ZS710943	2-63						
PL710684	2-2	ZS710965	2-83x						

 **AKAI ELECTRIC CO., LTD.**
AKAI TRADING CO., LTD.

(P.O. BOX 21, Tokyo International Airport, Japan)
12-14, 2-chome, Higashi-Kojiya, Ohta-ku, Tokyo, Japan

TELEPHONE: TOKYO (742) 5 1 1 1

CABLE: HIFI AKAI TOKYO TELEX: J2626 1

Printed No. 1481240 Printed in Japan Price \$6.00