

SERVICE MANUAL

PARTS LIST



AKAI SEMI-AUTOMATIC TURNTABLE
MODEL AP-002
ALSO APPLICABLE TO MODEL AP-002D



SEMI-AUTOMATIC TURNTABLE

MODEL AP-002

ALSO APPLICABLE TO MODEL AP-002D

SECTION 1	SERVICE MANUAL	3
SECTION 2	PARTS LIST	31

SECTION 1

SERVICE MANUAL

TABLE OF CONTENTS

I.	SPECIFICATIONS	4
II.	DISMANTLING OF UNIT	5
III.	AUTOMATIC RETURN MECHANISM	6
	1. AUTOMATIC RETURN	9
	2. INOPERATIVE PITCH	10
	3. FORCE (MANUAL) CUT	10
IV.	VARIOUS ADJUSTMENT	19
	(1) RETURN POSITION ADJUSTMENT	20
	(2) CYCLE CHANGE (MOTOR PULLEY CHANGE)	20
V.	PLAYER CARE	21
	1. LIFE OF NEEDLE (STYLUS TIP)	21
	2. NEEDLE CHANGE	21
	3. LUBRICATION	21
VI.	BLOCK DIAGRAM	22
VII.	ADJUSTMENT CHART	24

I. SPECIFICATIONS

MODEL	AP-002	AP-002D
1. TYPE	Belt drive, automatic return	Belt drive, automatic return
2. CARTRIDGE	M.M type, APC-2 (VM)	M75B/2
3. OUTPUT VOLTAGE	2.2 to 4.4 mV, 1000 Hz, 50 mm/sec	2.2 to 6.0 mV 1000 Hz, 50 mm/sec
4. FREQUENCY RESPONSE	20 Hz to 25,000 Hz	20 Hz to 20,000 Hz
5. CROSS TALK	Better than 15 dB, 1,000 Hz	Better than 17 dB, 1,000 Hz
6. OUTPUT BALANCE	Within 3 dB	Within 2.5 dB
7. COMPLIANCE	5 to 8×10^{-6} cm/dyne	20×10^{-6} cm/dyne
8. STYLUS PRESSURE	2.5 gr \pm 15%	2.5 gr \pm 15%
9. STYLUS TIP	0.5 mil diamond tip (APN-2)	0.6 mil diamond tip (N75B/2)
10. TONE ARM	Static balanced type tubular arm with inside force canceller and lateral balance weight	Static balanced type tubular arm with in- side force canceller and lateral balance weight
11. MOTOR	4-pole synchronous motor	4-pole synchronous motor
12. TURNTABLE	300 mm aluminum alloy diecast	300 mm aluminum alloy diecast
13. REVOLUTIONS	33-1/3, 45 r.p.m.	33-1/3, 45 r.p.m.
14. WOW & FLUTTER	Less than 0.15%	Less than 0.15%
15. S/N RATIO	Better than 30 dB	Better than 30 dB
16. POWER CONSUMPTION	Less than 17W	Less than 17W
17. DIMENSIONS	442(W)x185(H)x377(D)mm (17.4"x7.3"x14.8")	503(W)x185(H)x410(D)mm (19.8"x7.3"x16.1")
18. WEIGHT	7 kg (15.4 lbs.)	8 kg (17.6 lbs.)

II. DISMANTLING OF UNIT

In case of trouble, etc. necessitating disassembly, please disassemble in the order shown in photographs. Re-assemble in reverse order.

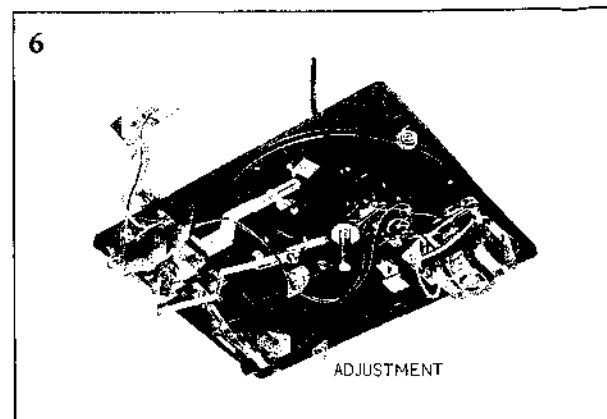
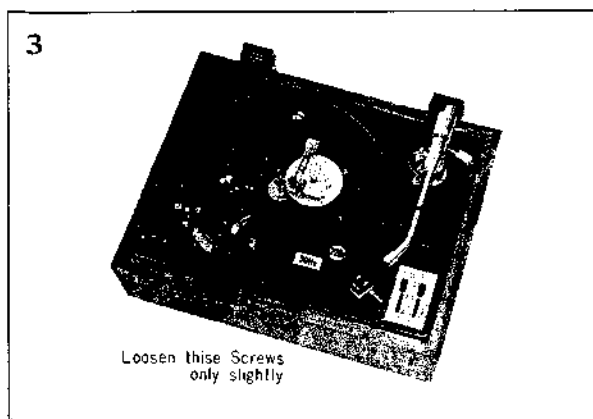
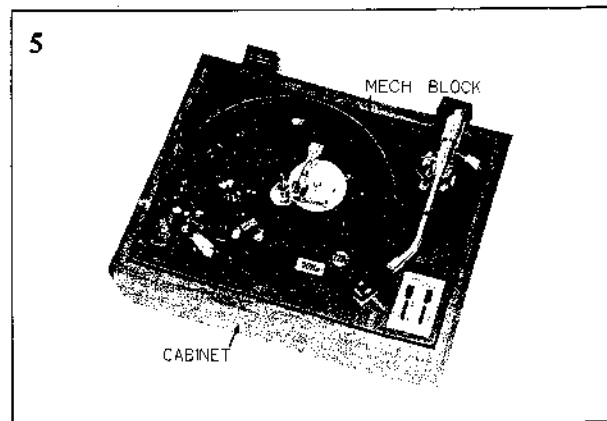
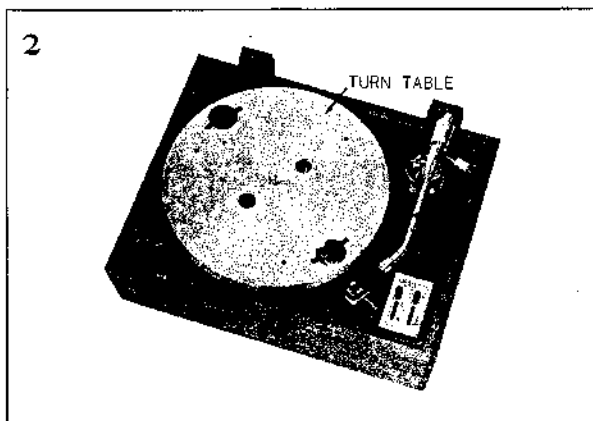
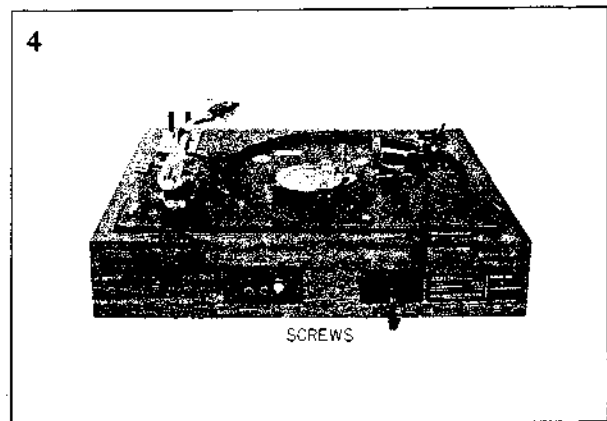
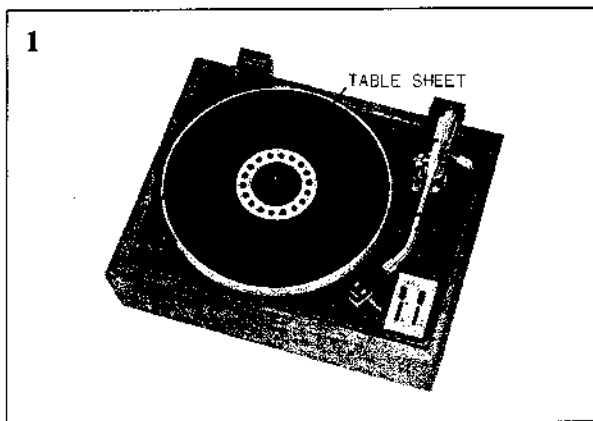

III. AUTOMATIC RETURN MECHANISM

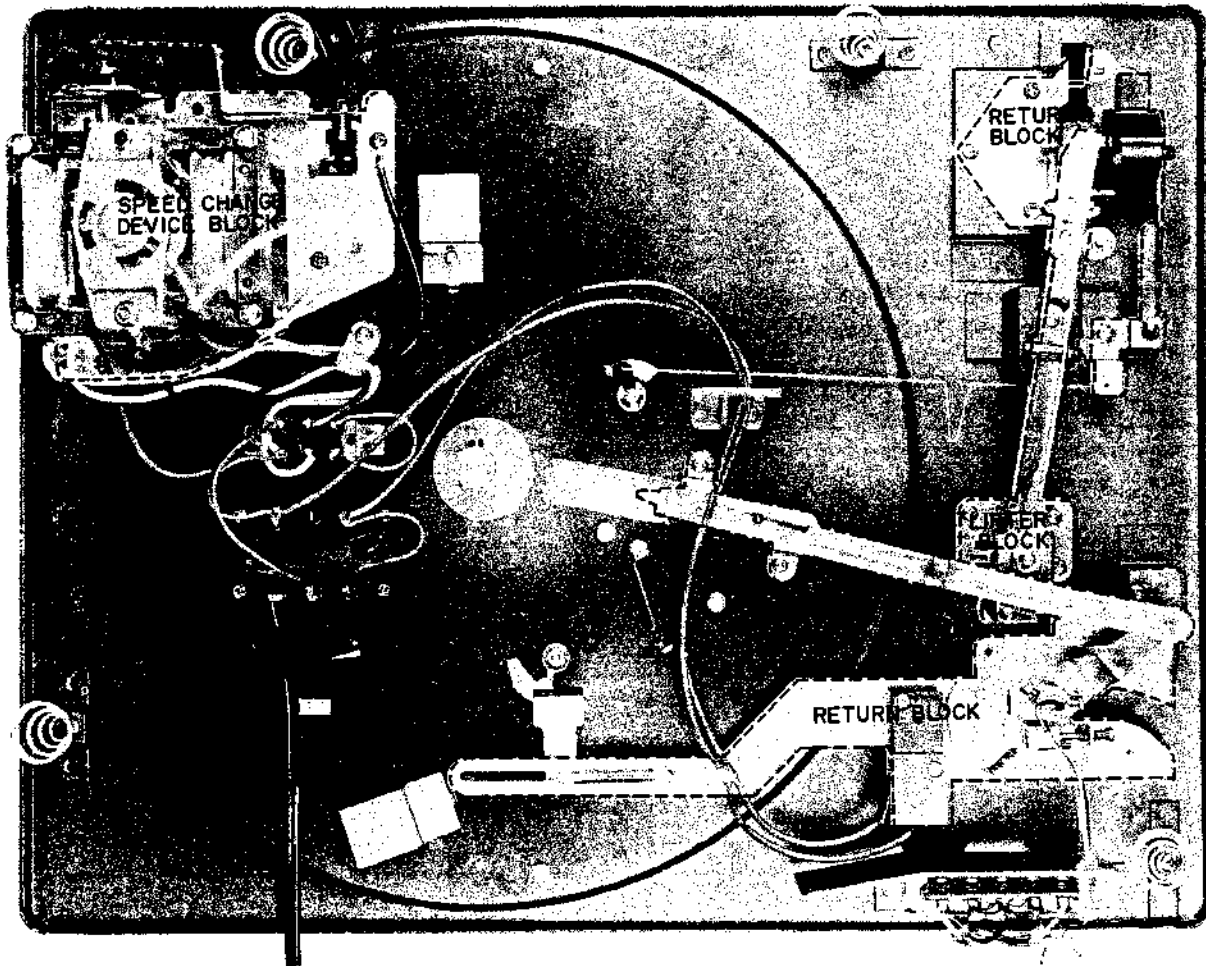

Fig. 1

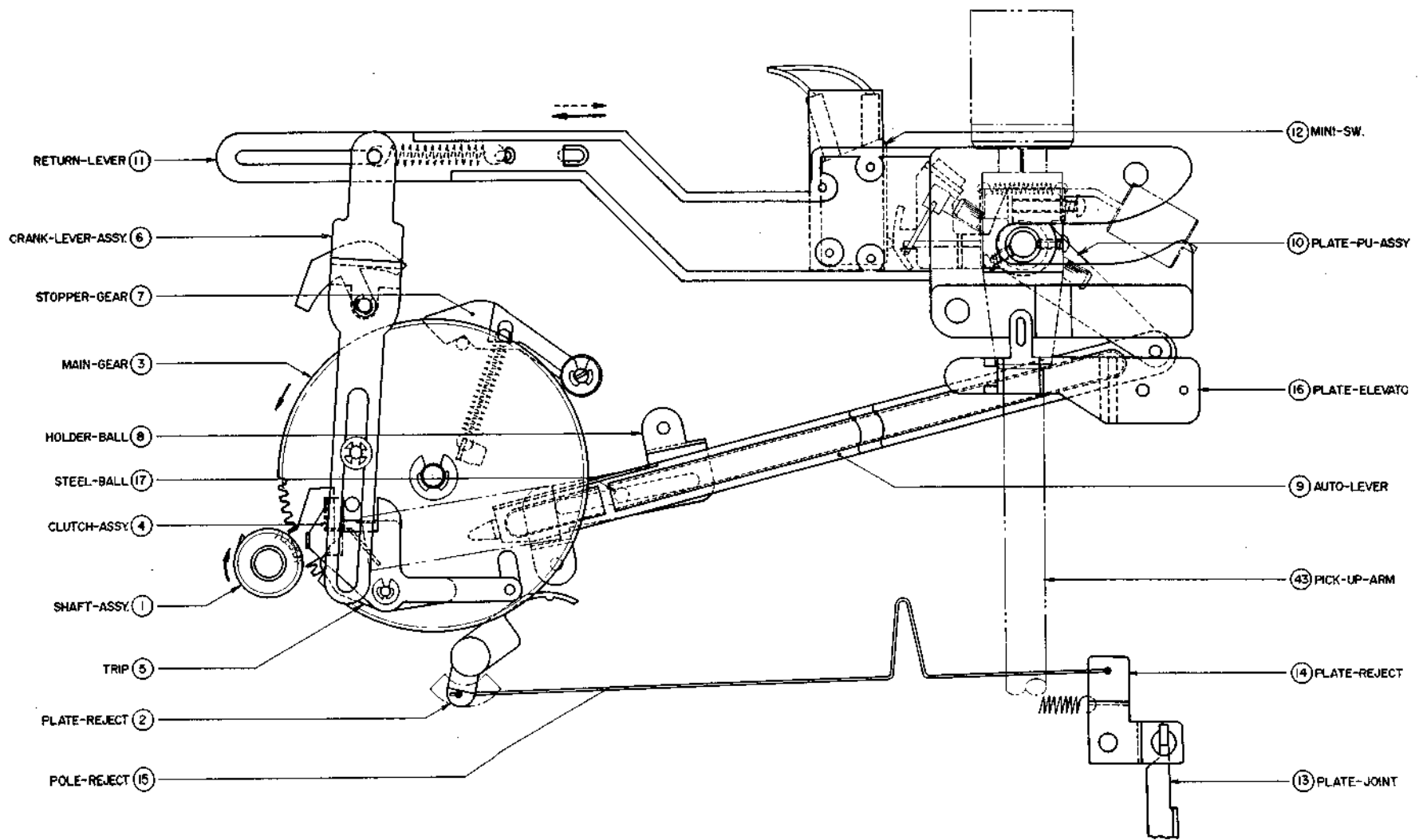
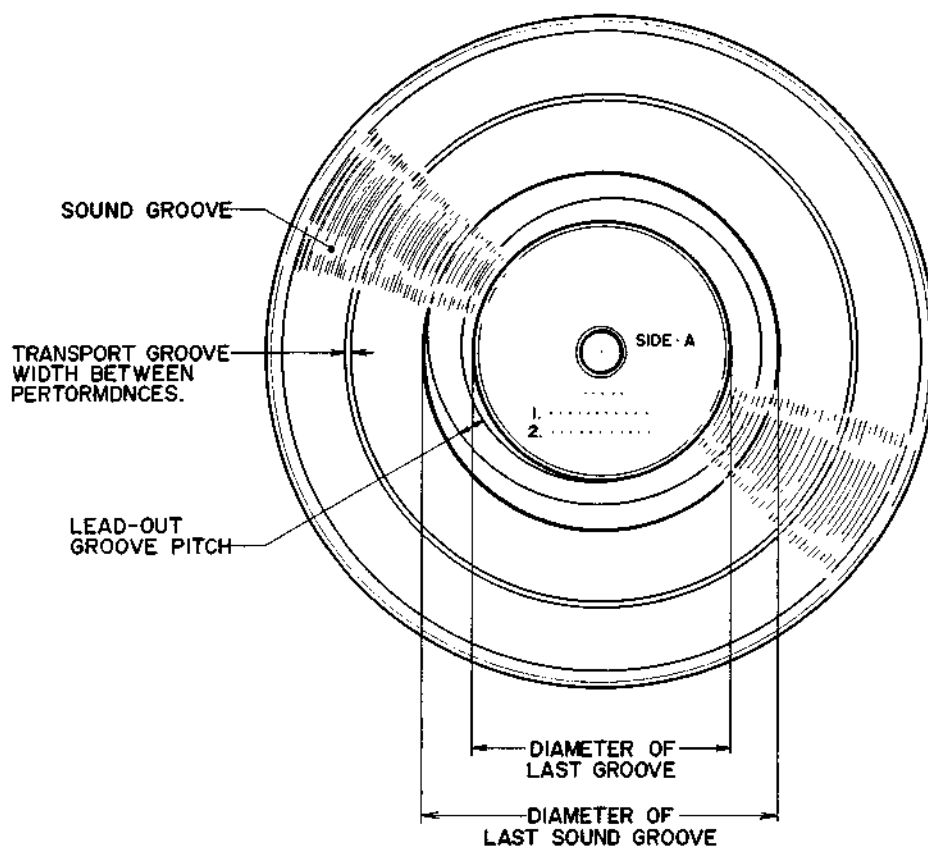

Fig. 2 MAIN PARTS OF AUTOMATIC MECHANISM



The return mechanism of this machine is as shown in Fig. 2. Because of the use of "speed displacement type" perception equipment, when the program (performance) ends, and the pick up needle advances in lead-out groove, the perception equipment operates regardless of disc size (in case of JIS specification equivalent). That is to say that because the speed displacement type perception equipment operates with 100% certainty, the proper type of record becomes important. There are several different specifications. For instance, domestic JIS, and foreign IEC, RIAA, etc., but this machine is designed to operate as per JIS specifications. Below is a summary of JIS record dimensions necessary for automatic return.

- Transport groove: If transport groove diameter is within 230 mm, and this pitch or transport width is within 1 mm.
- Lead-out groove: Lead-out groove pitch is 4 to 9 mm and linkage is made to the last groove at more than one revolution.
- Last groove: Last groove is always linked from lead-out groove at concentric circle.

RECORD TYPE	17 cm	17 cm	25 cm	30 cm
HEADING	45 r.p.m.	33 r.p.m.		
Last Sound Groove Diameter	More than 106	More than 106	More than 115.2	More than 115.2
Last Groove Diameter	97±1	97±1	106.4±0.8	106.4±0.8

A gear the same as the pitch of MAIN GEAR (3) is installed to the SHAFT TABLE ASSY (1) and here a plectrum-like part projects from this part. Because this plectrum is for the purpose of picking up the timing of CLUTCH-ASSY (4) installed on the MAIN-GEAR (3) it rotates with the turntable during record performance. AUTO LEVER (9) is linked to the PLATE-PU-ASSY (10) which is directly connected to the pick up arm, and TRIP (5) begins to be pressed from about the time stylus tip reaches the lead-out groove. The movement of this AUTO-LEVER (9) is about 1/6 in relation to the movement of the stylus tip.

RETURN LEVER (11) is linked to MAIN GEAR (3) by CRANK LEVER ASSY (13) and reciprocal motion is in accordance with MAIN GEAR (3) revolutions. Then at the // slanted portion (hatching), PLATE ELEVATOR (16) is raised and the lifter (at \odot mark position) is elevated and the arm returned to the arm rest. Further, because current ON-OFF switch MINI-SW (12) is installed on RETURN LEVER (11), this switch operates to automatically stop turn table rotation when the pick up arm is returned to the arm rest. Because STOPPER GEAR (7) controls the revolving motion of MAIN GEAR (3), it operates to stop rotation so that the tooth gap part comes to a standstill at an established position near TABLE SHAFT ASSY (1).

Also in case the record is stopped during performance, PLATE JOINT (13), PLATE REJECT (14) and POLE REJECT (15) are intervened by the forward motion of CAM REJECT LEVER, PLATE REJECT (2) operates, and CLUTCH ASSY (4) is pushed out.

1. AUTOMATIC RETURN

As shown in Fig. 3 when the pick up arm moves to the record surface, the PLATE-PU ASSY (10) which is directly connected to the arm shaft separates from MINI SW (12), power source is turned ON, and the turntable rotates. As the pick up stylus tip traces the recorded groove of the record, AUTO LEVER (9) also advances on the inner side proportionately. Because this AUTO LEVER advances as the STEEL BALL (17) on HOLDER BALL (8) rolls, movement is extremely smooth and there is almost no influence extended to pick up arm side pressure.

In due time the pick up stylus finishes sound groove tracing and about the time it enters the lead-out groove, the tip of AUTO-LEVER (9) begins to push the skirt part of TRIP (5) and the CLUTCH ASSY (4) which rides lightly on this part is pushed out toward the TABLE SHAFT ASSY (1) (shown in Fig. 5, when the pick up stylus is at a about 126 mm position from the turntable).

At this condition, the protruding part of the gear on TABLE SHAFT ASSY (1) is drawn to CLUTCH ASSY (4) and the MAIN GEAR begins to rotate (Fig. 6). Up to now MAIN GEAR (3) had been held at a standstill by STOPPER GEAR (7) and a smooth stop effected by the teeth gap, but when the condition in Fig. 6 is assumed the teeth begin to mesh together and rotating motion begins. Then as shown in Fig. 7, this motion by means of CRANK LEVER ASSY (6) moves RETURN LEVER (11) in the direction of the arrow, and PLATE ELEVATOR (16) is raised and the lifter is elevated. When pick up arm elevation is complete, as shown in Fig. 8, the part indicated by broken line of RETURN LEVER (11) hits the cushion part attached to the tip of PLATE PU ASSY (10) and pick up arm return commences. When the pick up arm returns to the rest, the RETURN LEVER (11) by means of CRANK LEVER (6) moves in the opposite direction (broken arrow mark), PLATE PU ASSY (10) returns to former position, and in due course approaching MINI SW (12) is operated and the power source is turned OFF so that the condition in Fig. 3 is re-assumed.

2. INOPERATIVE PITCH

As can be seen by the JIS specification summary above, record sizes entail 3 kinds of specifications, and these are classified into 2 categories which are directly related to automatic return. These are 17 cm and 25/30 cm dimensions. For perception of return position of these two kinds of records, in the case of in-operative part of gear (less than 1 mm) the operating principle of the perception equipment is as follows: On a 17 cm record the last sound groove trace is in the vicinity of 110° .

However, on a 30 cm record the sound groove has already ended at the vicinity of 110° and the stylus has passed the lead-out groove and is moving to the last groove (concentric circle) at about this time (1.8 mm radius).

Therefore, when the pick up arm comes to this vicinity, if it is a 30 cm record, return operation must commence, and if it is a 17 cm record, the last trace must yet be effected. The difference in circumstances of these two records lie in the volume of movement of the stylus advancement within one single revolution. In the case of a 17 cm record, because this pitch is very limited (less than 1 mm), it is satisfactory if the CLUTCH ASSY is kicked back by the protruding part of the TABLE SHAFT ASSY as shown in Fig. 10 each time the record makes one revolution.

For details of this kicked back condition, refer to Fig. 11. The gamma (γ) (kick back volume) is about 0.6 m/m and on a 17 cm record even with a transport pitch of 1 mm, the CLUTCH ASSY cannot retrieve this kicked back portion.

Regardless of how many times the record rotates, the transport pitch is less than 1 mm and the clutch assembly continues to be kicked back. (Fig. 12) (Even if the record is traced to about 97° vicinity (outside of specifications), if the transport pitch is less than 1 mm, return will definitely not be effected during the performance), (this occurs only when the TRIP is pushed).

However, because practically all marketed records are JIS or equivalent, when the stylus advances to about 106° vicinity and moves to the lead-out groove, the transport pitch suddenly increases (4 to 9 mm). When this happens, the CLUTCH ASSY movement which to now could not retrieve the 0.6 mm kick back volume suddenly is increased (over 1.2 mm), and on the next revolution when the protruding part approaches, meshing takes place and return begins.

In this manner the "speed displacement type return mechanism utilizes the operating pitch and regardless of whether the record is 17 cm or 30 cm, return is effected at the end of record performance.

3. FORCE (MANUAL) CUT

When listening to a record and you wish to stop in the middle of a performance, or when playing a record not according to specifications, and the stylus tip has advanced to the last groove, simply bring the cut lever forward. This moves PLATE REJECT 2 which pushes PLATE JOINT (13), then POLE REJECT (15) and ultimately CLUTCH ASSY (4) is pushed as shown in Fig. 13. (\leftarrow mark). Then return operation commences and the power source is turned OFF (Refer to Item 1 above and Fig. 5).

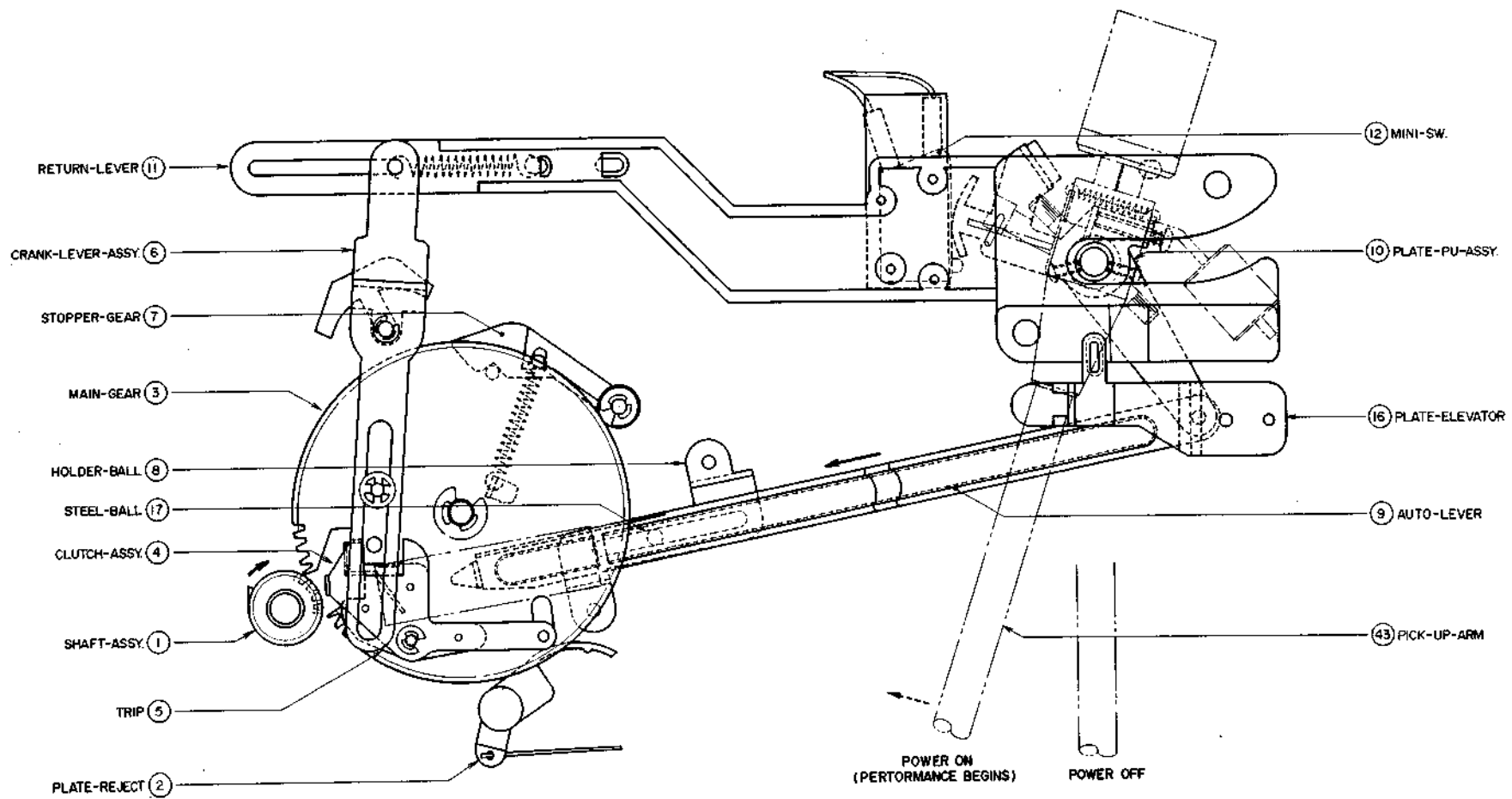

Fig. 3

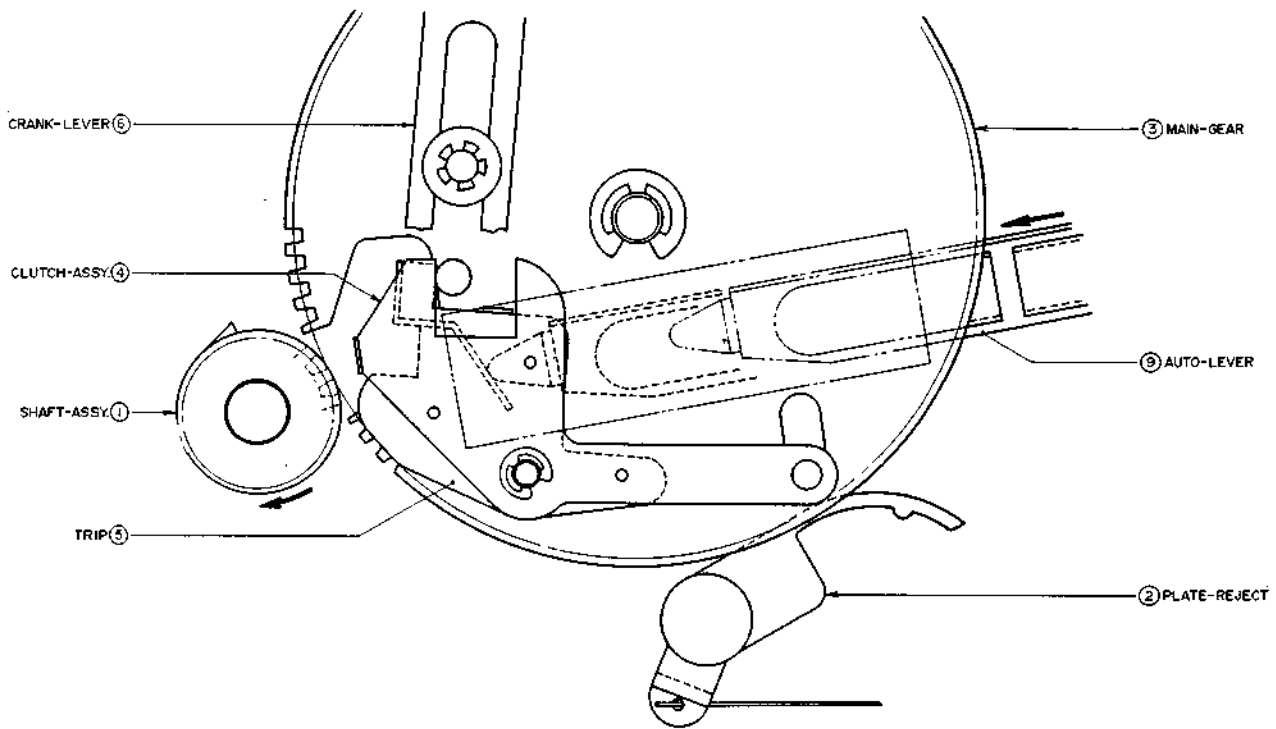

Fig. 4

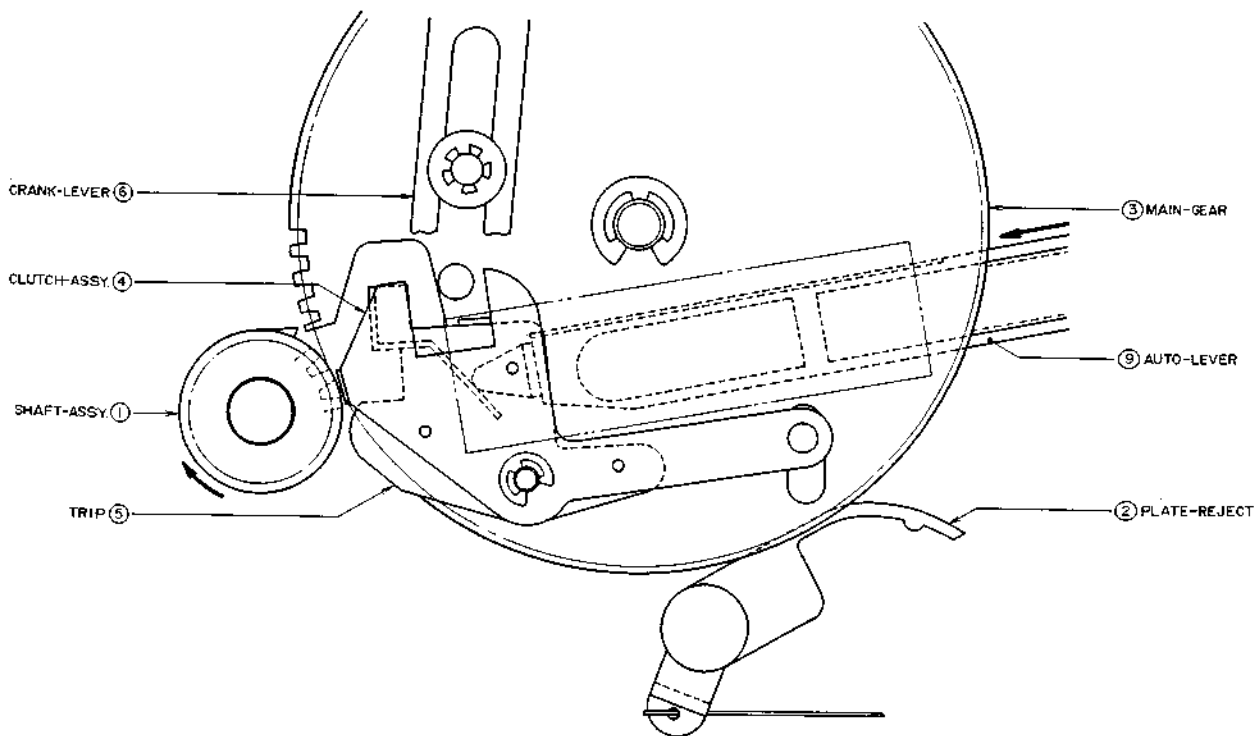

Fig. 5 PICK UP ARM STYLUS TIP IN VICINITY OF 126 ϕ

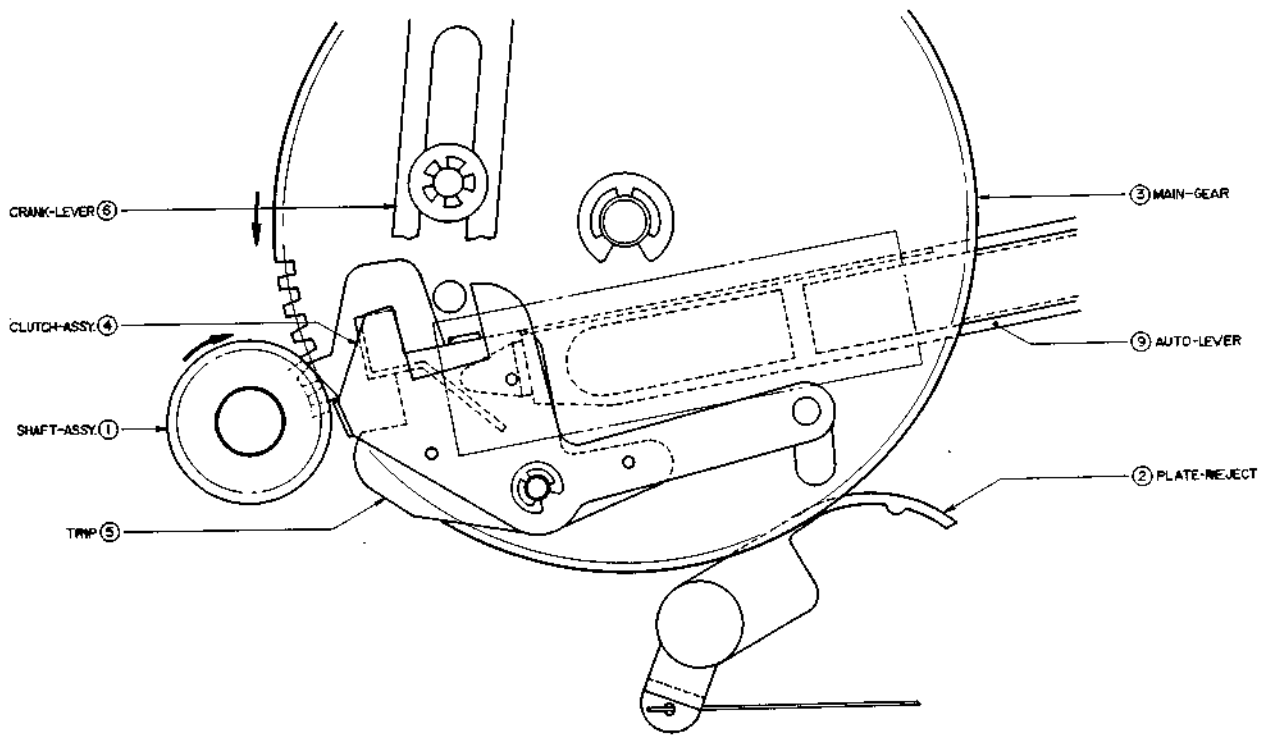

Fig. 6 MAIN-GEAR REVOLUTIONS BEGIN (AUTO RETURN BEGINS)

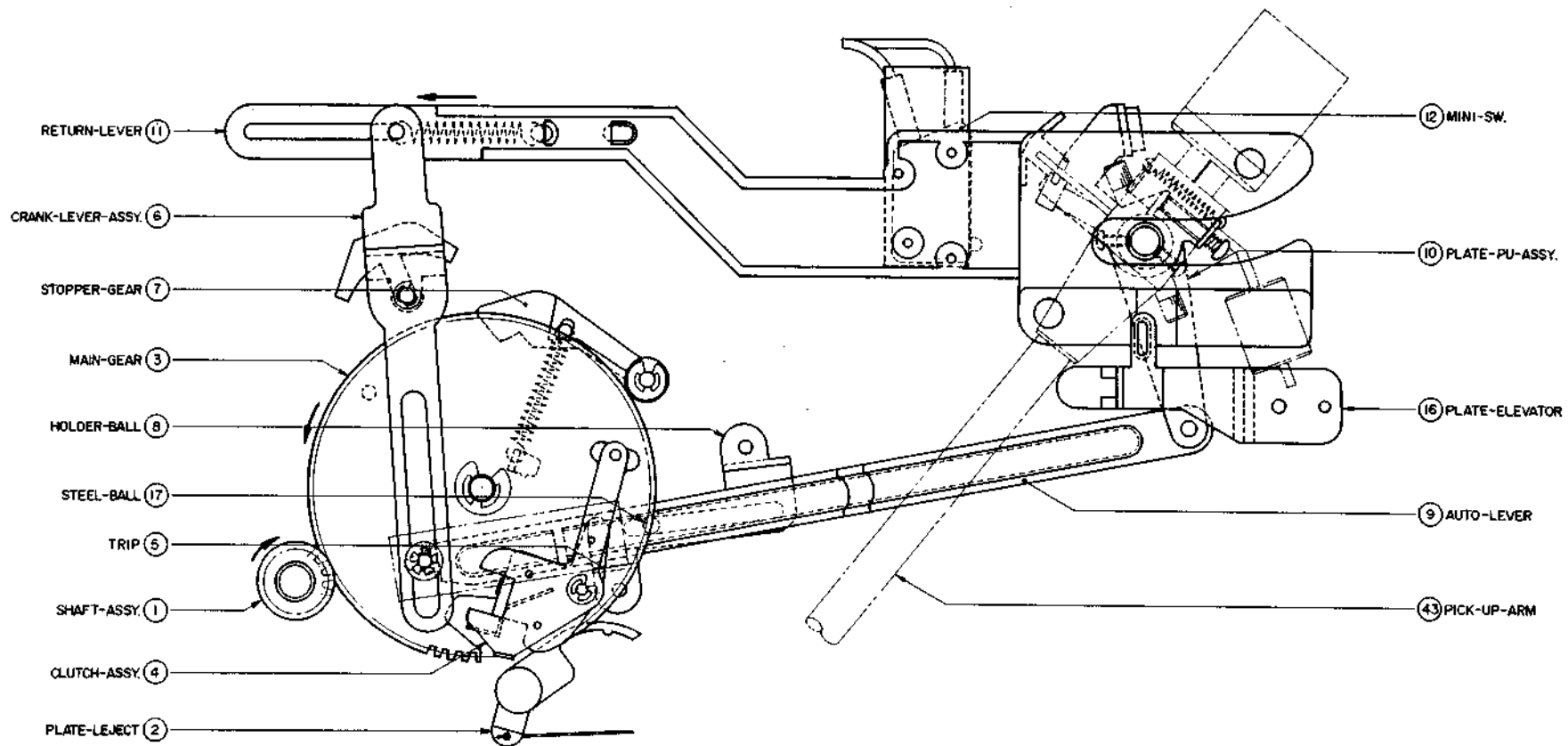

Fig. 7 PICK UP ARM ELEVATION COMMENCES

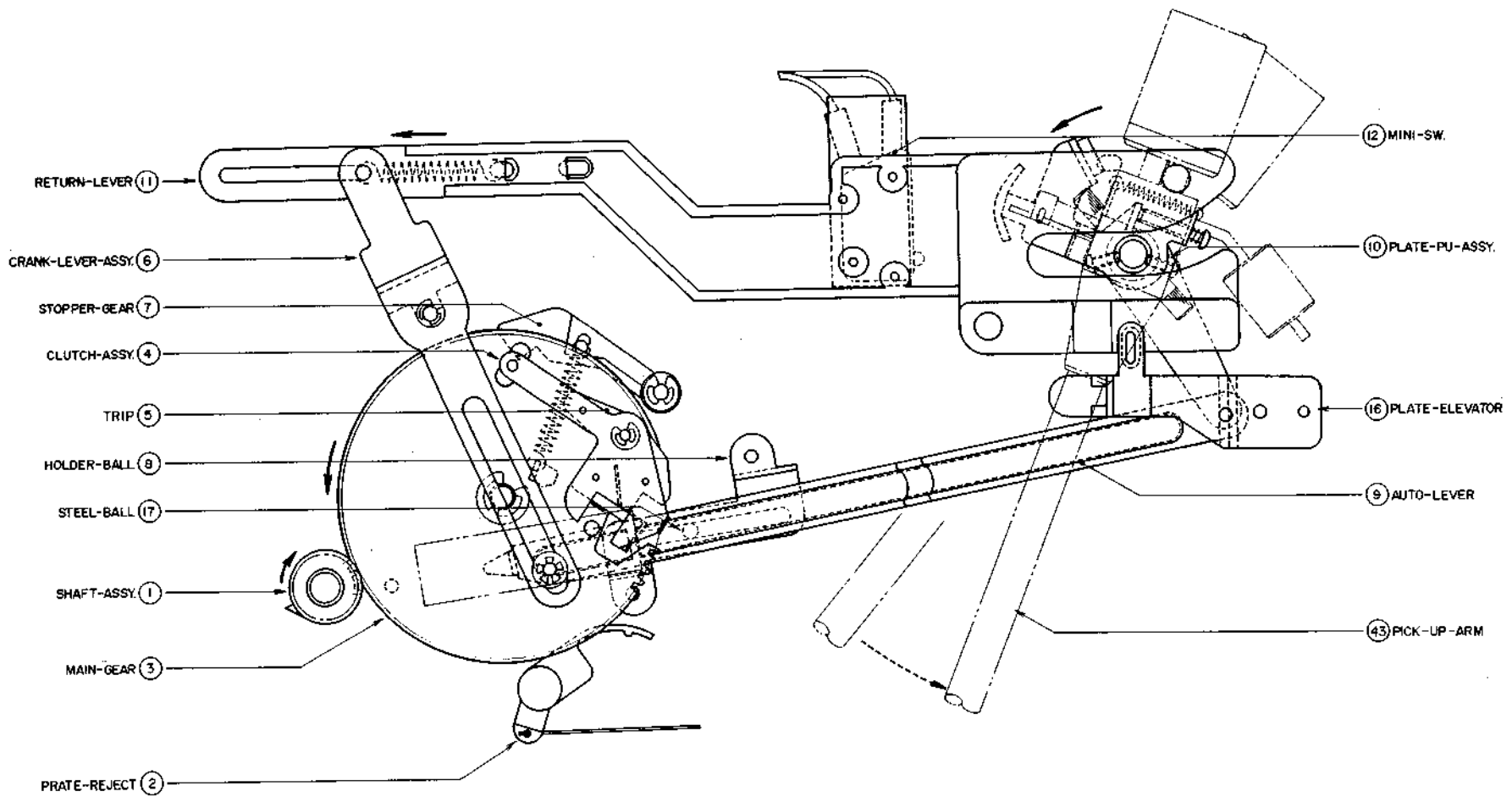

Fig. 8 PICK UP ARM RETURN COMMENCES

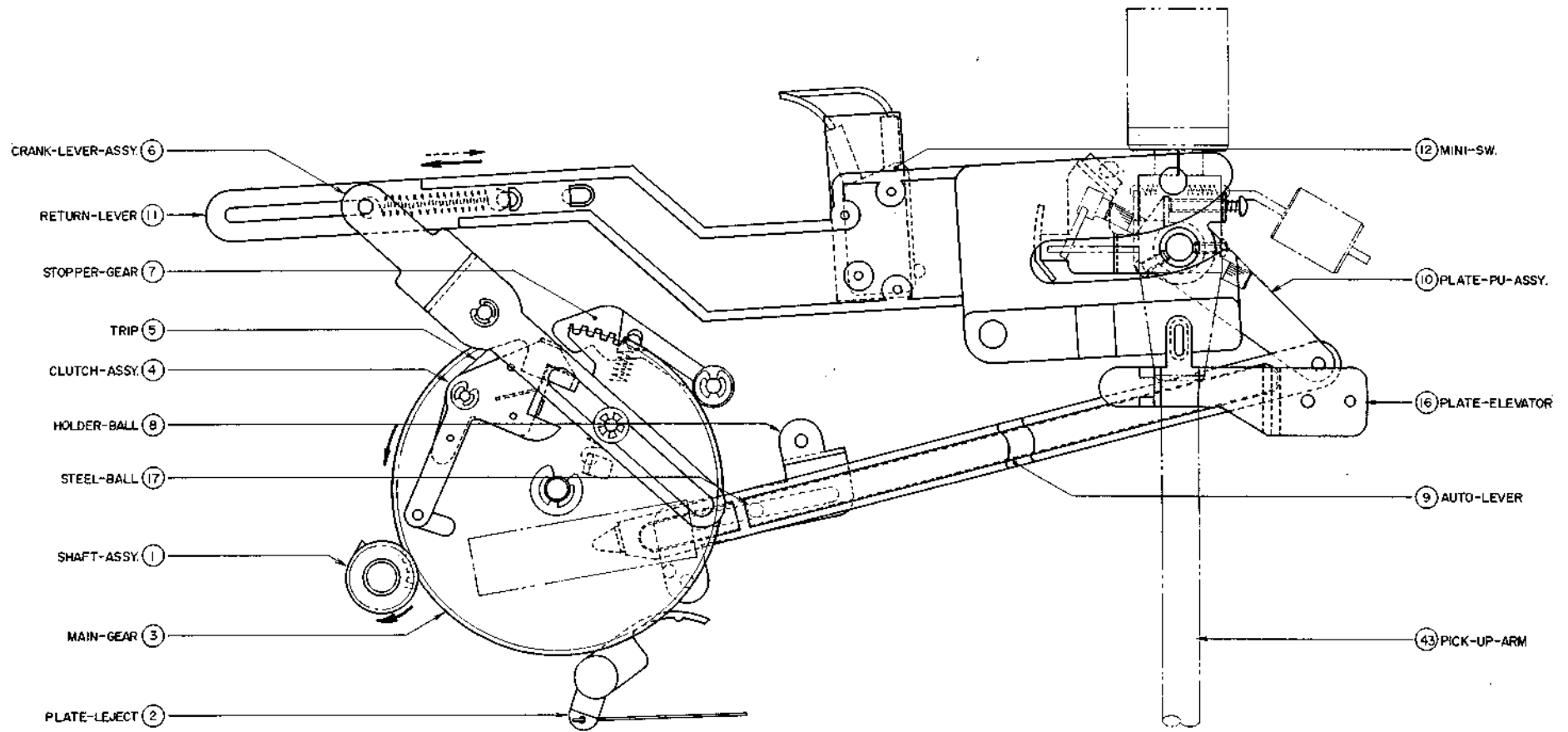

Fig. 9 PICK UP ARM ON REST TURNTABLE REVOLUTIONS CONTINUE

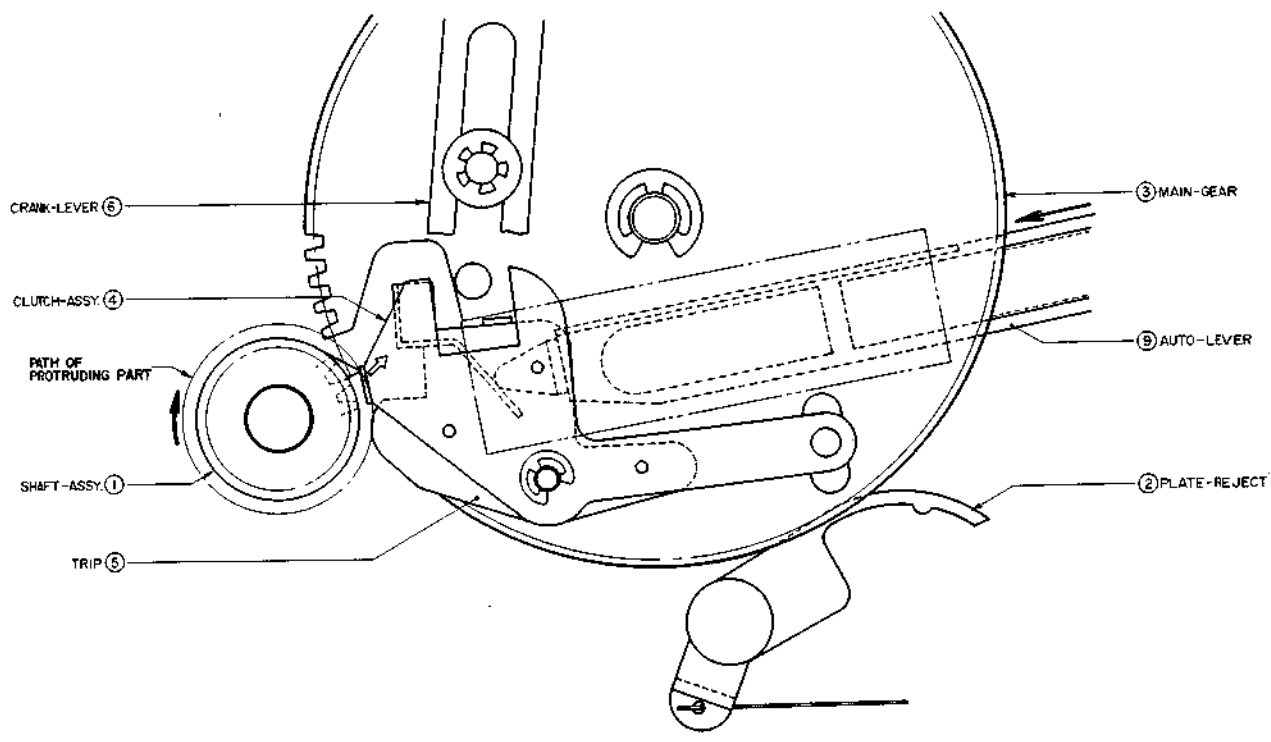

Fig. 10 NON RETURN CONDITION

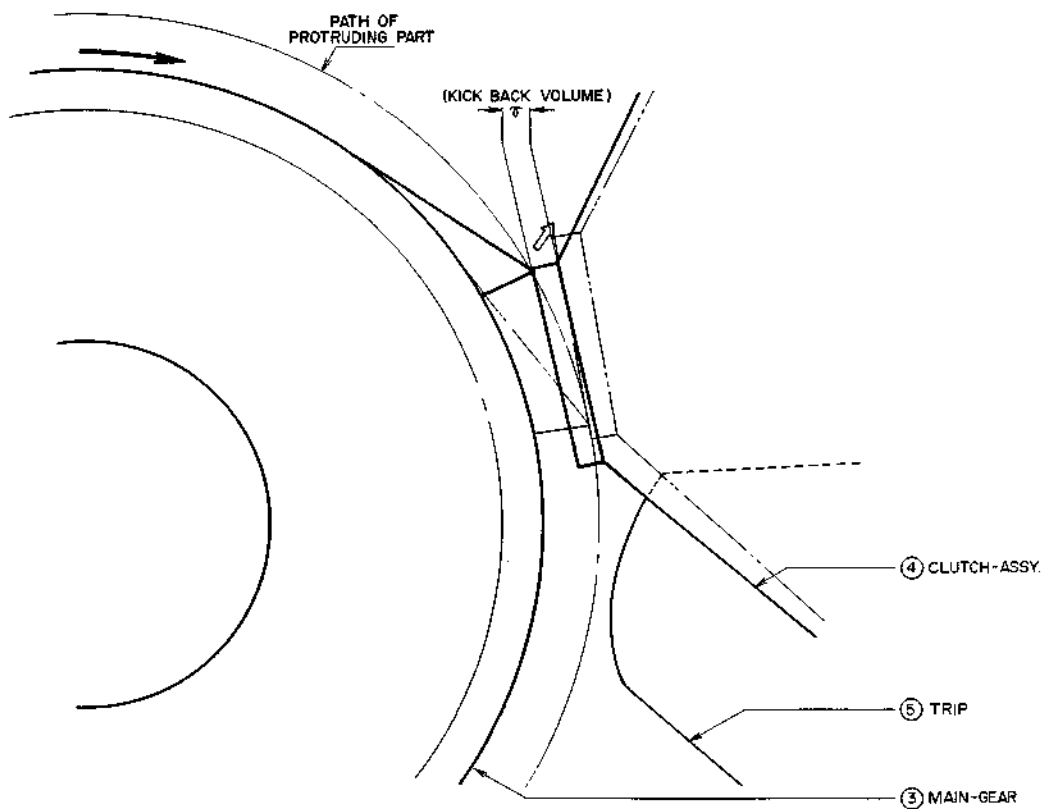

Fig. 11

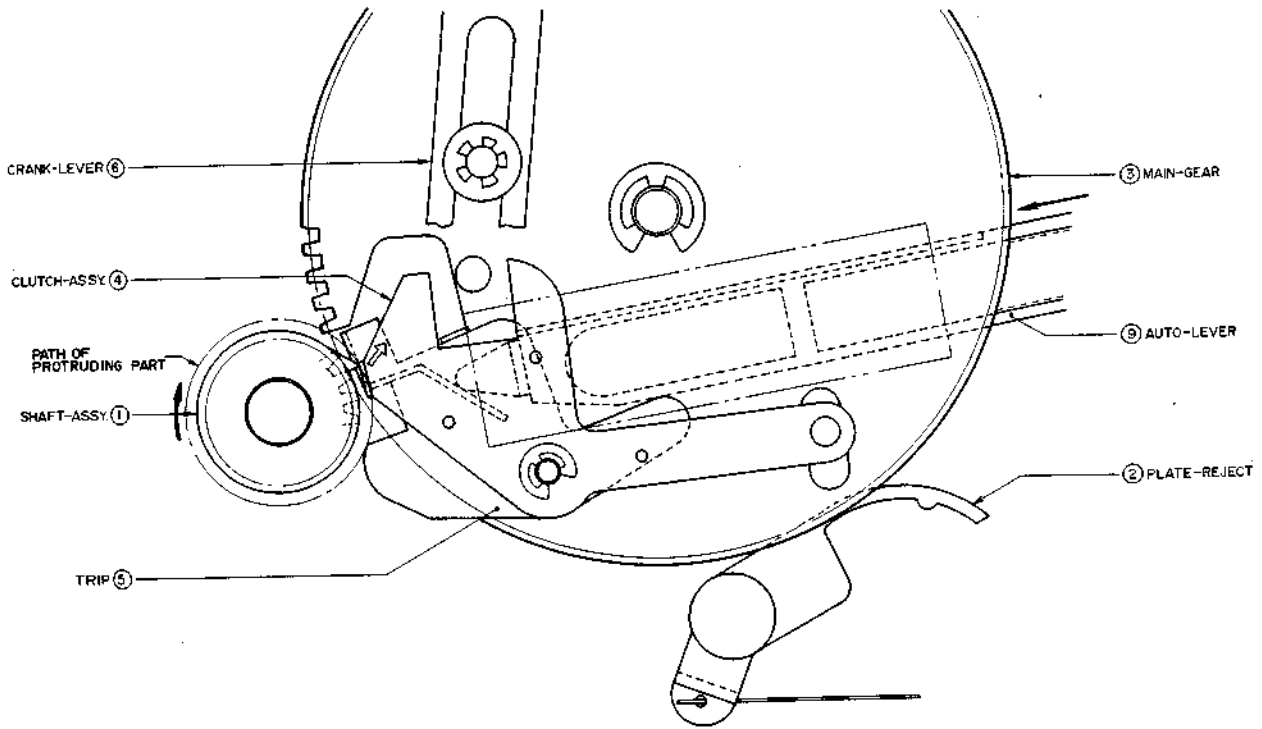

Fig. 12 NON RETURN CONDITION

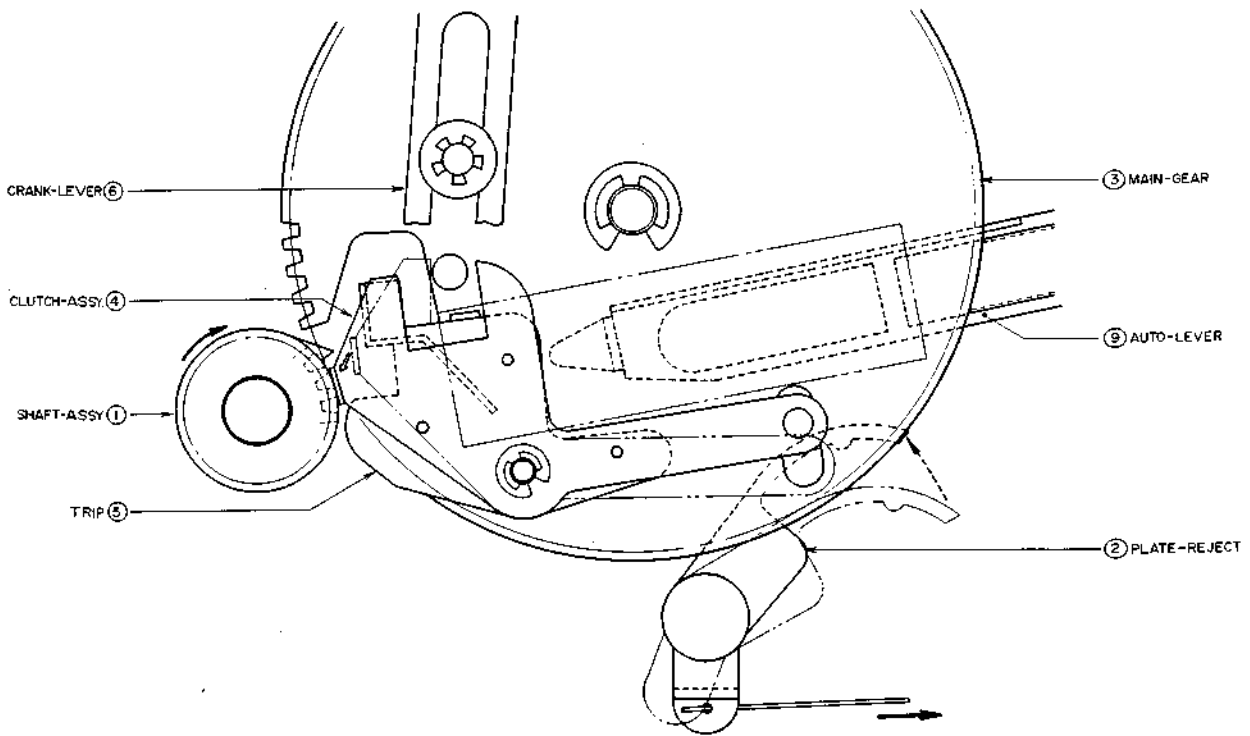

Fig. 13 FORCE CUT

IV. VARIOUS ADJUSTMENT

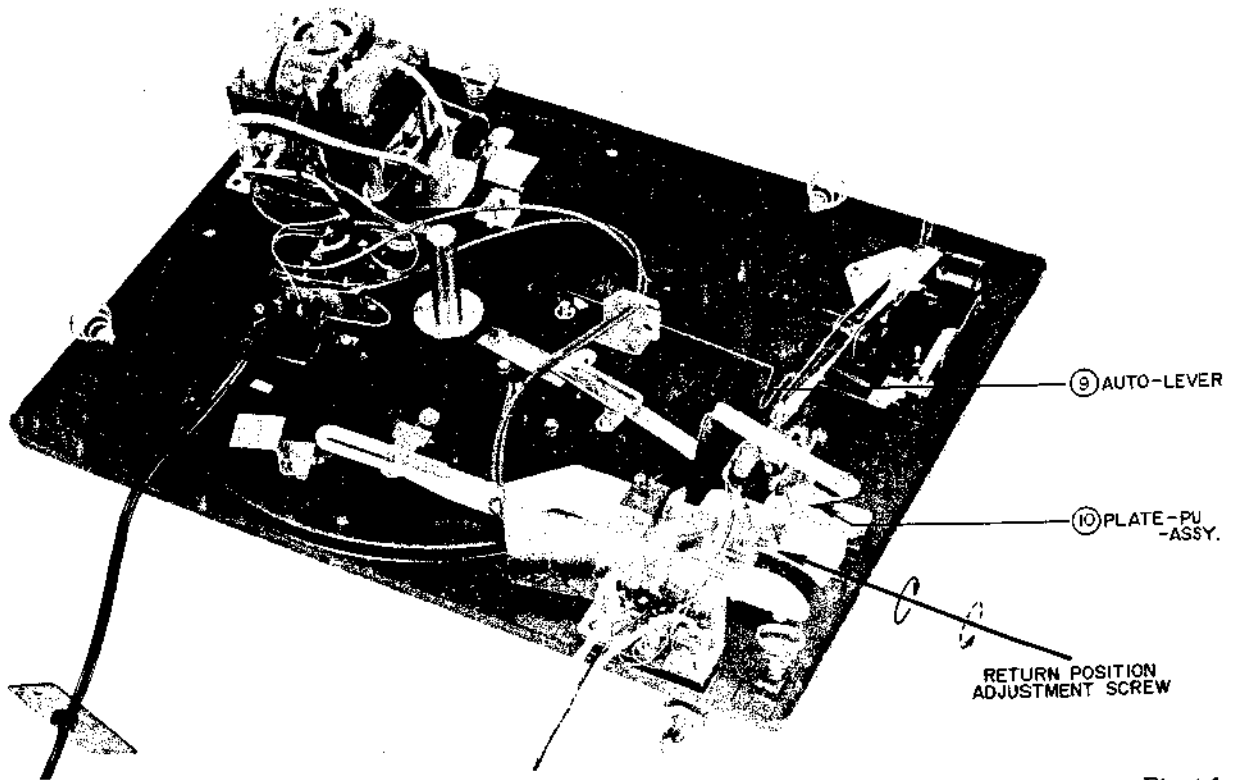

Fig. 14

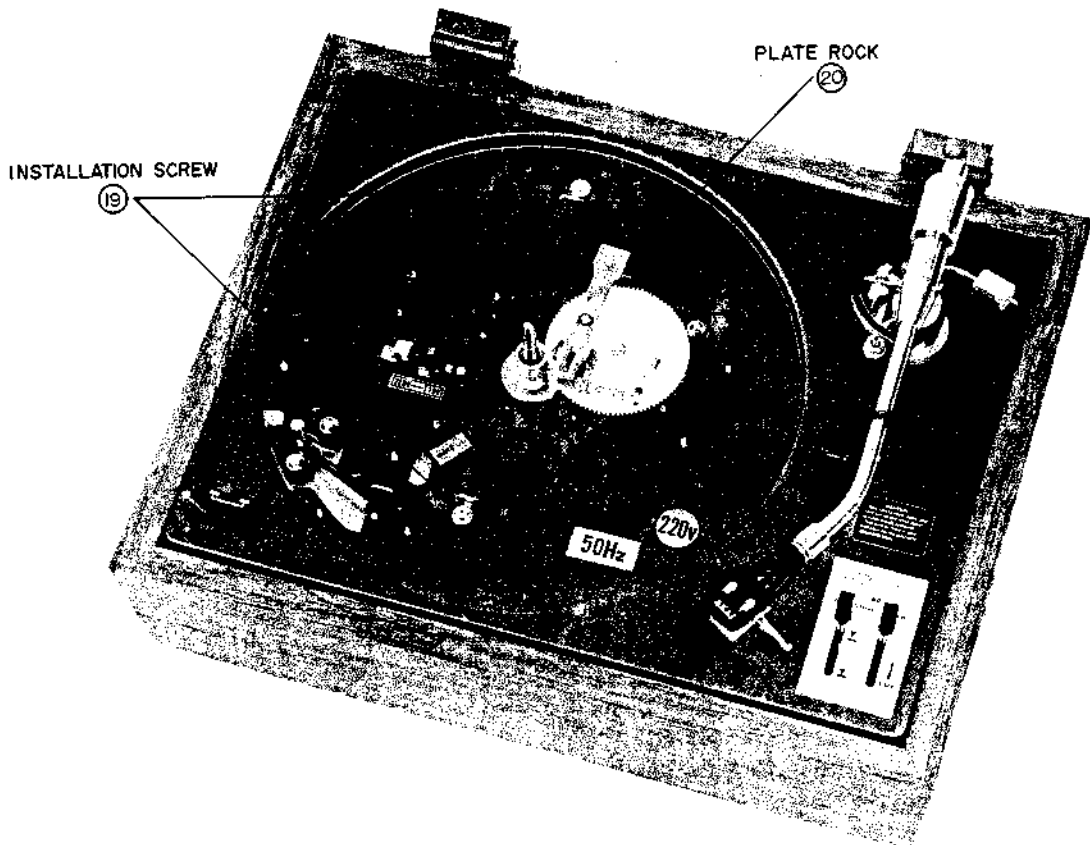

Fig. 15

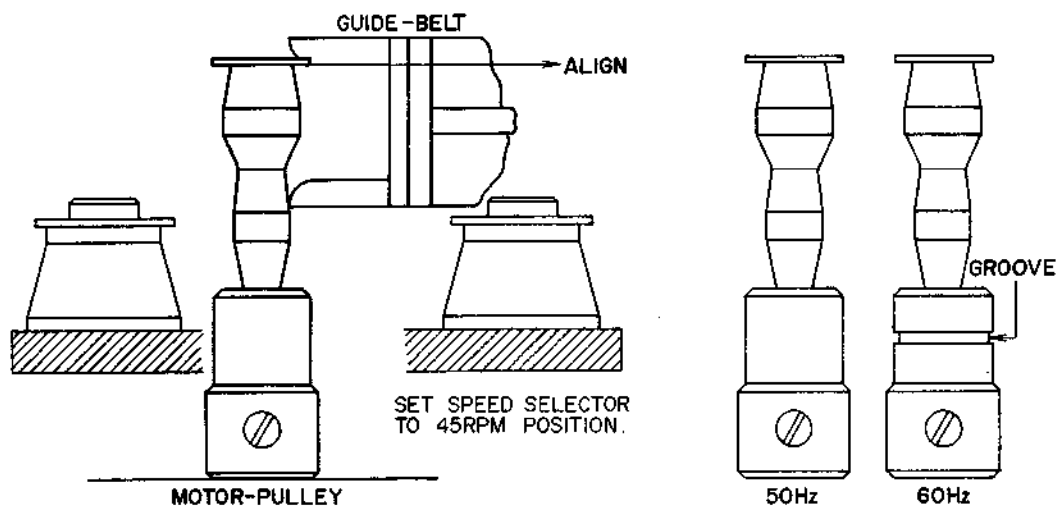

Fig. 16

All of the stationary parts of this machine are ideally adjusted prior to shipment. However, the following adjustments are necessary according to circumstances involving usage:

(1) RETURN POSITION ADJUSTMENT

Remove turntable and loosen the plate holder metal fitting (PLATE LOCK (20)). This can be accomplished after loosening the two installation screws (19) on the table mount 2 or 3 turns. (Fig. 15) Because this separates the table mount and the cabinet by a considerable degree, the return position adjustment screw (18) located on the reverse side of the PU Arm becomes accessible. Adjust with plus driver (Fig. 14) As shown in Fig. 14 when the adjustment screw is turned to the right (in direction of solid line), the return position is slowed (inside circumference approach) and when the adjustment screw is turned to the left (in direction of broken line), the return position is speeded up (outside circumference approach). (When the adjustment screw is turned 1 revolution, the position of the PU Arm stylus tip is changed by about 8 m/m).

Always confirm this adjustment with a JIS specification 30 cm LP record. Also while the turntable is removed, confirm that the CLUTCH ASSY (4) begins to move out when the PU Arm stylus tip is 64 mm (R) to 70 mm (R) from the turntable shaft center.

CAUTION: If adjustment cannot be made without turning the adjustment screw (18) more than 2 revolutions, because this is likely to be caused by improper installment position of PLATE PU ASSY (10) and TRIP (5), CLUTCH ASSY (4) etc. (by position of other parts) check these points. Also after adjustment, be sure to return installment screws (19) to former position and tighten.

(2) CYCLE CHANGE (MOTOR PULLEY CHANGE)

Cycle change is effected by changing the motor pulley. 50 and 60 Hz differentiation can be determined by the groove on the 60 Hz pulley. (See Fig. 16)

While viewing horizontally as shown in the figure, install so that the lower part of the motor pulley brim and the lower part of the GUIDE belt are aligned (Refer to figure).

(Set Speed Selector to 45 r.p.m. position).

When the player is turned ON and the turntable rotates, if a rubbing noise from the belt can be heard, (except while switching) and operation is not smooth, further adjust pulley height by moving up and down slightly and position for best adjustment.

V. PLAYER CARE

1. LIFE OF NEEDLE (STYLUS TIP)

The life time of the needle is about 500 hrs. of use (both sides of about 500 30 cm LP records). If the needle becomes old, because the record will be damaged and tone quality will become inferior, be sure to replace as soon as is needed. The needle will wear especially fast and the record surface will be scratched if records on which dust is allowed to accumulate are played. Therefore, please be sure to keep record clean by wiping and cleaning the record grooves with water soaked gauze. Also if dust adheres to the turntable mat as this will cause the record to become dirty easily, the mat should also be kept clean.

2. NEEDLE CHANGE

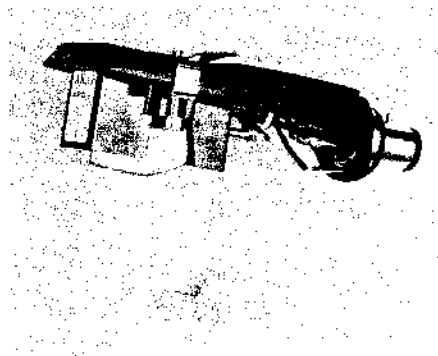

When replacing needle, use only one of the replacement types listed below.

APN-2
N75B/2 (SHURE)

3. LUBRICATION

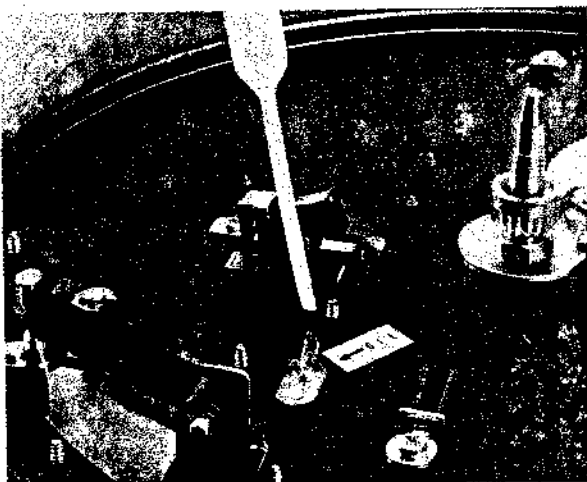

Because for rotating parts and parts which rub together during operation, oilless metal and the best grease is used, your machine will need lubrication for some time. Oil at points shown in illustration about once per year using standard accessory player oil. In case you have run out of standard accessory oil, use #60 spindle oil or a high grade machine oil. If used continually for business purposes, etc., oil about once or twice per month.

CAUTION: Following lubrication, because oil will adhere to the drive belt and pulley and to the turntable etc., wipe the oil off of these parts with a cloth to which a little carbon tetrachloride or thinner (benzine can be also be used) has been applied.

VI. BLOCK DIAGRAM

1. Model AP-002 (A)

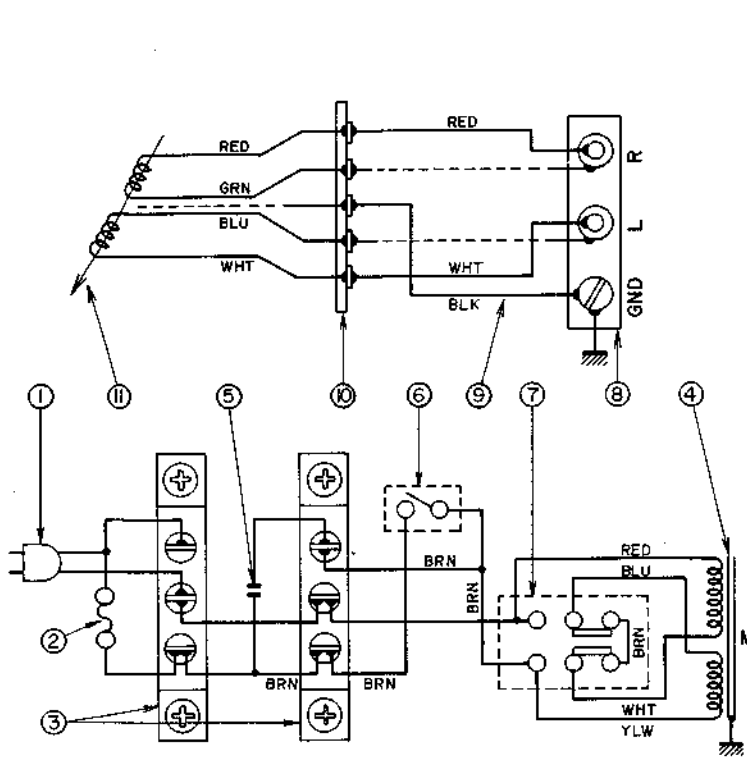

NOTE:
SWITCH INSTALLMENT DIRECTION

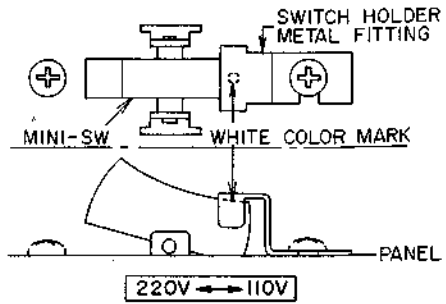

NO.	DESCRIPTION	Qty	CODE NO.
1	CORD-PWR-UC	1	2217619900
2	FUSE-IJ	1	2214422400
3	TERMINAL-3P	2	2216130200
4	MOTOR-AC-4-A	1	2212540400
5	CMM0.047-M-1000D	1	2237013900
6	MINI-SW	1	2214585400
7	SEESAW-SW	1	2214644700
8	TERMINAL-CPX	1	2216204900
9	SHILD-IC	1	2217822000 2217821900
10	TERMINAL-IL-4P	1	2216105700
11	CARTRIGE-MM	1	2215530000

Fig. 17

2. Model AP-002 (B)

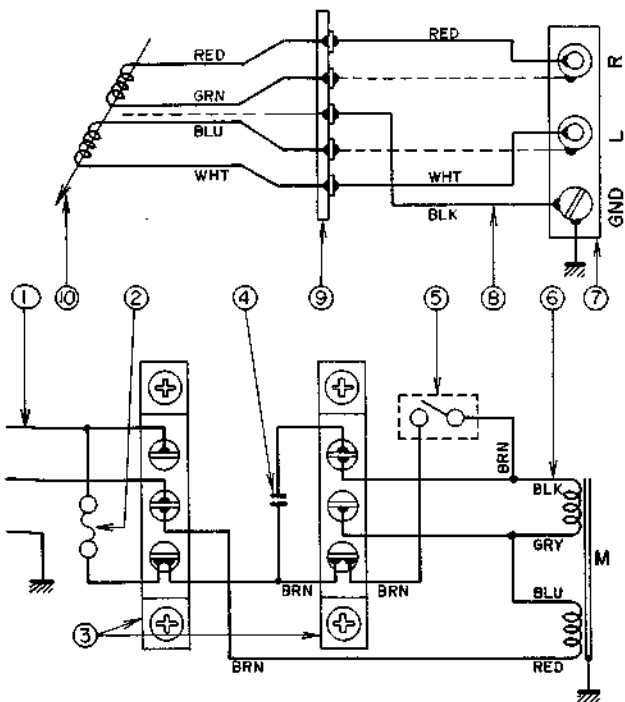

NO.	DESCRIPTION	Qty	CODE NO.
1	CORD-PWR-SA	1	2217705100
2	FUSE-IJ	1	2214422400
3	TERMINAL-3P	2	2216130200
4	CMM0.047-M-1000D	1	2237013900
5	MINI-SW	1	2214585400
6	MOTOR-AC-4-B	1	2212540500
7	TERMINAL-CPX	1	2216204900
8	SHILD-IC	1	2217822000 2217821900
9	TERMINAL-IL-4P	1	2216105700
10	CARTRIGE-MM	1	2215530000

Fig. 18

3. Model AP-002D

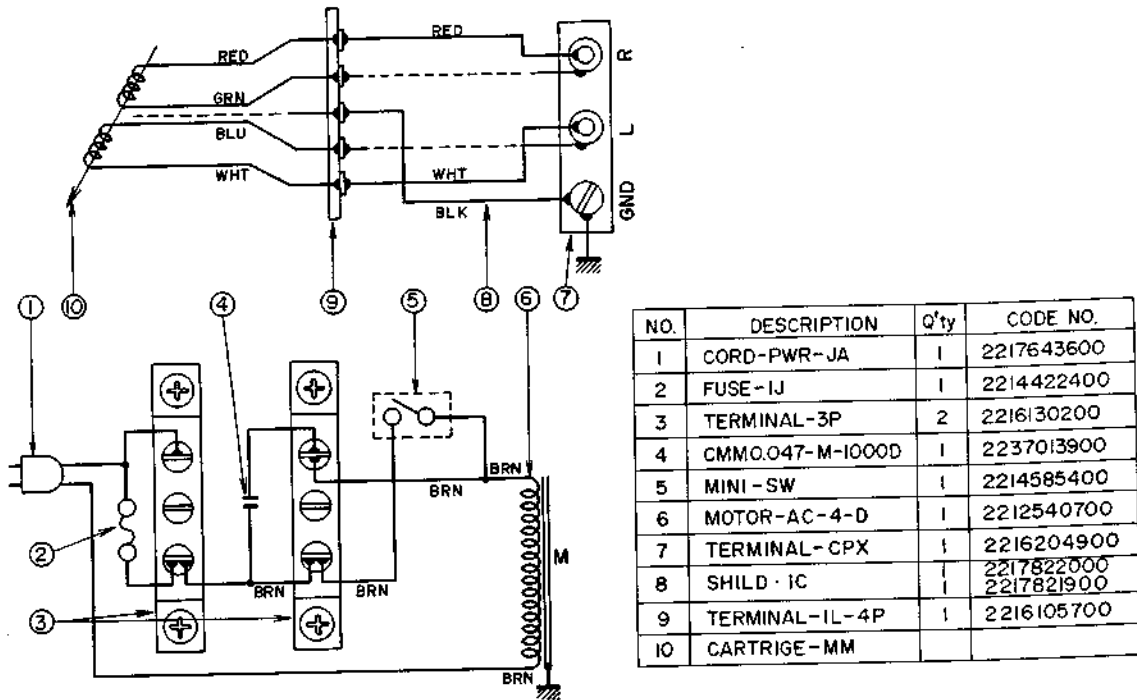

Fig. 19

VII. ADJUSTMENT CHART

CONDITION	EXPLANATION	SOURCE AND SYMPTOM	COUNTERMEASURE
Poor tone quality	1. Distortion (when using a new quality record)	<p>Faulty cartridge Distortion persists after changing needle and confirming normal pick up arm operation. (Amp speaker normal)</p> <p>Worn needle Crackling sound even when playing new record. Especially vague at high range</p> <p>Stylus pressure inadequate Needle sinks to far into cartridge body during record playback (too much pressure) Sound completely distorted. Needle jumps (insufficient pressure)</p> <p>Bent Stylus A crunching sound exists and the level of right and left differs greatly. Also loss in directional sensitivity. Sudden change in sound level</p> <p>Bust adhering to stylus tip Sound is vague or distortion exists</p>	<p>Replace cartridge</p> <p>Replace needle.</p> <p>Readjust stylus. Pressure</p> <p>Replace stylus.</p> <p>Clean stylus tip.</p>
	2. Hum Noise	<p>Lead wire from pick up and power source wiring is too close together Hum is altered by changing position of lead wire</p> <p>Insufficiently grounded When pick up arm or player body is touched with your hand, hum noise increases. No sound from side (or both channels) and only a hum is emitted.</p>	<p>Check wire and correct.</p> <p>Check amp input grounding from cartridge. Player and amp connection Plug in pin plug cord perfectly.</p>
	3. Left/Right sound separation poor	<p>Faulty cartridge Using a monaural record, left right sound scatters and is not emitted from the center. (Amp speaker connections are correct) (Confirm that the plus & minus terminals are not reversed on one side at cartridge output pin and shell pin connection)</p>	<p>Replace cartridge.</p>
	4. Distortion at one CH only	<p>Bent pick up head Observe head during record performance. Pick up arm rotating shaft faulty Check pick up arm side pressure. At zero balance arm does not move smoothly by means of inside force canceller.</p> <p>Faulty operation of AUTO-LEVER (9) Is there sufficient loose play between AUTO-LEVER (9) and PLATE-PU-ASSY (10) connection part? Are these parts bent? Is steel ball (8) movement smooth?</p> <p>Trip (5) function faulty Is there sufficient loose play at TRIP and CLUTCH ASSY (4) installation? Are these parts bent?</p>	<p>Replace pick-up arm.</p> <p>Replace pick-up arm.</p> <p>Straighten or replace.</p> <p>Straighten or replace.</p>
	5. Absolutely no sound	<p>Pin plug cord is disconnected or solder has come off of lead wire connection. Confirm connections with tester</p> <p>Shorted or wire inside cartridge Check cartridge terminal DC resistance with tester. (L-ch, R-ch)</p>	<p>Correct.</p> <p>Replace cartridge.</p>

CONDITION	EXPLANATION	SOURCE AND SYMPTOM	COUNTERMEASURE
Unusual noise	1. Mechanical noise (direct noise)	<p>Contact of GUIDE BELT (21) and BELT (22) Relative height of MOTOR-PULLEY and GUIDE BELT (21) poor. (Remove turntable and check)</p> <p>Vibration interference from Motor (MOTOR-AC-4 (24)) rotation. During motor rotation, if player panel or pick-up arm is touched with your hand, vibration is evident. Direct rotating noise is audible.</p> <p>Abnormal automatic mechanism noise Check for irregular shape of CLUTCH-ASSY (4) and TRIP (5) STOPPER GEAR (7) needs greasing.</p> <p>Variation in MOTOR PULLEY (23) During revolutions, check MOTOR PULLEY vibration, form variation, and eccentricity.</p>	<p>Adjust MOTOR PULLEY height.</p> <p>Adjust motor installation.</p> <p>Replace motor.</p> <p>Correct replace.</p> <p>Grease. Replace Motor pulley.</p>
	2. Electrical noise (from speaker)	<p>Lead wire leak or pin plug cord connection faulty. Sometimes shock noise and hum is emitted. Interference when lead wire is touched. No noise periodically. Check with Tester.</p> <p>Defective cartridge Interference when upper part of shell is lightly tapped.</p> <p>Rumbling noise from motor (MOTOR AC-4 (24)) rotation vibration. During motor revolutions, vibration occurs when player mount table and arm is touched with your hand. (Confirm that shipping screws have been removed).</p>	<p>Correct lead wire wiring. Make proper pin plug cord connection.</p> <p>Replace cartridge.</p> <p>Adjust motor installation.</p> <p>Replace CUSHION-RB-MD</p>
Turntable does not rotate (or rotation is unstable.	1. Electrical circuit problem	<p>Loose or broken lead wire Faulty soldering Faulty switch (SW-MINI (12)) Fuse blown Check with tester according to schematic diagram.</p>	<p>Correct wiring.</p> <p>Replace switch. Replace fuse.</p>
	2. MOTOR out of order (MOTOR AC-4)	<p>Coil open or shorted wire Check coil lead through with Tester. Rotor shaft needs oil or shaft is being caught by something. Rotate rotor by hand and check.</p>	<p>Replace motor.</p> <p>Clean around rotating shaft and oil.</p>
	3. Table shaft out of order	<p>Table shaft and bearing defective When turntable in rotated by hand it seems heavy. There is a noise as soon as the turntable is stopped. Too much rattle. (Remove belt & check) Needs oil Irregular noise when turntable is rotated by hand.</p>	<p>Replace table shaft, bearing</p> <p>Grease replace.</p>
	4. Speed change mechanism defective	<p>Relative position of BELT (22) and GUIDE BELT (21) poor. Belt rubbing noise. Belt does not come to specified position (drum like part) of MOTOR PULLEY. Speed change is not smooth.</p>	<p>Adjust MOTOR PULLEY height. Adjust ADJUSTMENT Nut.</p>
	5. Revolutions too slow or uneven.	<p>(After confirming distortion in Item 4) Inferior BELT (22) Is contact side of belt inferior? Discolored or misshapen? Check for belt stretch.</p>	<p>Replace belt.</p>

CONDITION	EXPLANATION	SOURCE AND SYMPTOM	COUNTERMEASURE
Automatic mechanism does not function.	1. Unstable return	<p>PLATE-PU-ASSY (10) installation loose Are the two installation screws (26) perfectly tight?</p> <p>PLATE-PU-ASSY coil spring (27) has come off. Are both ends of the spring fastened to hook aperture?</p> <p>Faulty PLATE-PU-ASSY (10) Is coil spring (27) having any effect? Is it too loose or bent? Is operation smooth? Where the two plates are hinged together?</p> <p>Mutual relativity of PLATE-PU-ASSY (10) and AUTO LEVER (9) unsuitable Is installment position of PLATE-PU-ASSY correct? Is there proper loose play where PLATE-PU-ASSY and AUTO LEVER are linked?</p> <p>AUTO LEVER (9) FAULTY Irregular noise when PU ARM is moved (rubbing noise) Is it bent? No loose play at all where PLATE-PU-ASSY (10) is linked or too much loose play.</p> <p>5/32" STEEL BALL (17) is out of place Is the STEEL BALL (28) between AUTO LEVER (9) and HOLDER BALL (8) in place?</p> <p>TRIP (5) Faulty Movement is not smooth when PU ARM is moved lightly toward inner circumference. Is it bent, warped, or does it have uneven edges? Check especially for misshapen skirt part and check condition of tip part.</p> <p>Faulty CLUTCH ASSY (4). (insufficient kick-back volume) Is it bent, warped, or misshapen? Are there uneven edges at parts influenced by operating function?</p> <p>TRIP (5) and CLUTCH ASSY (4) relativity unsuitable When PU ARM is moved lightly toward inner circumference does CLUTCH ASSY ride on TRIP and move together? Is movement smooth?</p>	<p>Tighten installation screw (26).</p> <p>Fasten coil spring (27).</p> <p>Replace PLATE-PU-ASSY (10).</p> <p>Adjust PLATE-PU-ASSY (10) according to installation regulations.</p> <p>Replace AUTO-LEVER (9).</p> <p>If 5/32" STEEL BALL (17) has come out, reinsert.</p> <p>Replace TRIP (5).</p> <p>Adjust to specified kick-back volume (0.6) or replace.</p> <p>Replace both TRIP (5) and CLUTCH (4).</p>

CONDITION	EXPLANATION	SOURCE AND SYMPTOM	COUNTERMEASURE
	2. Does not return	<p>Mutual relativity of PLATE PU ASSY (10) and AUTO LEVER (9) unsuitable</p> <p>CLUTCH ASSY (4) does not move out even when PU ARM approaches 130° position from table shaft center.</p> <p>PLATE PU ASSY (10) installation loose</p> <p>Is installation screw (26) perfectly tight?</p> <p>Mutual relativity of TRIP (5) and AUTO LEVER (9) unsuitable.</p> <p>Is skirt part of TRIP (5) misshapen?</p> <p>Is tip part of AUTO LEVER (9) misshapen?</p> <p>STOPPER GEAR (7) does not work properly</p> <p>Is coil spring (29) properly installed?</p> <p>When MAIN GEAR (3) is rotated, it is unusually heavy (LEVER CRANK ASSY (6) bent)</p> <p>Coil-Spring (30) improperly installed.</p> <p>Confirm.</p> <p>Protruding part on SHAFT TABLE ASSY (1) causing over kick-back.</p> <p>Check whether stand-up part of CLUTCH ASSY (4) is misshapen or has uneven edge, etc.</p>	<p>Adjust return position with Return Adjustment screw (18)</p> <p>Tighten installation screw (26)</p> <p>Repair bent or misshapen parts of both TRIP (5) and AUTO LEVER (9) or replace.</p> <p>Install coil spring properly or straighten bent LEVER CRANK ASSY.</p> <p>Properly install coil spring</p> <p>Replace CLUTCH ASSY (4)</p>
	3. POWER SOURCE is not turned off even when return function has ended. (Turntable continues to rotate)	<p>LEVER CRANK ASSY (6) misshapen or bent</p> <p>Gap between SW-MINI (12) and PLATE-PU-ASSY (10) too large (If more than 2mm, switch will not function.)</p> <p>Has stop ring (31) become separated?</p> <p>PLATE-PU-ASSY (10) installation angle unsuitable</p> <p>The part moving to SW-MINI (12) is not coming to established position.</p> <p>SW-MINI (12) faulty or wrong wiring Short</p> <p>Check with tester according to schematic diagram.</p> <p>STOPPER GEAR (7) coil spring (29) too strong.</p> <p>Continuous rotation of MAIN GEAR (3) (CLUTCH ASSY projecting toward shaft table caused from stopper gear operation shock)</p> <p>POLE-REJECT (5) shorter than specified length (misshapen)</p>	<p>Replace LEVER-CRANK ASSY (6)</p> <p>Correct installation angle of PLATE-PU-ASSY (10).</p> <p>Readjust return position.</p> <p>Replace SW-MINI (12)</p> <p>Correct wiring.</p> <p>Check for slight coil spring (29) stretch.</p> <p>Replace spring.</p> <p>Make the V bend of POLE-REJECT (15) slightly wider.</p>
	4. Does not return when CUT KNOB is manipulated. (Distribution 1 to 3 is sufficient)	<p>PLATE-REJECT (3) constantly touching CLUTCH ASSY (4) pin.</p> <p>POLE REJECT (15) stretched</p> <p>When knob is manipulated PLATE REJECT (2) does not sufficiently move CLUTCH ASSY (4).</p> <p>PLATE JOINT (13) separation</p> <p>Confirm.</p>	<p>Make the V bend of POLE REJECT slightly narrower.</p> <p>Correct.</p>

CONDITION	EXPLANATION	SOURCE AND SYMPTOM	COUNTERMEASURE
	5. During performance PU Arm fails to continue advancement toward center (Needle jumps).	<p>Mutual relativity of PLATE-PU-ASSY (10) and AUTO LEVER (9) unsuitable.</p> <p>Is there sufficient play where PLATE-PU-ASSY and AUTO LEVER is linked?</p> <p>Is steel ball (17) inside HOLDER Ball (8) moving smoothly?</p> <p>Is AUTO LEVER misshapen?</p> <p>Has steel ball (17) fallen out?</p> <p>PU ARM Bearing faulty</p> <p>PU ARM horizontal angle incorrect even when PLATE PU ASSY (10) is removed.</p> <p>CLUTCH ASSY (4) and TRIP (5) not operating properly. (Movement heavy)</p>	<p>Correctly install PLATE-PU-ASSY (10).</p> <p>Replace AUTO LEVER.</p> <p>Re-insert 5/32" STEEL BALL (17) into place.</p> <p>Replace PU Arm.</p> <p>Clean or replace.</p>
		<p>Is there foreign matter or oil adhering to mutual contact surfaces? Are these parts misshapen or do they have uneven edges?</p> <p>Insufficient stylus pressure</p> <p>PU Arm is unusually light when touched with finger. (Playback sound vague or distorted).</p>	<p>Readjust to specified stylus pressure.</p>
	6. Returns during performance (using JIS specs record).	<p>Stand-up part of CLUTCH ASSY (4) misshapen or has uneven edges.</p> <p>Kick-back insufficient.</p> <p>Check for misshapen or uneven edges.</p> <p>Foreign matter or oil between CLUTCH ASSY (4) and TRIP (5).</p> <p>Is movement smooth when PU Arm is moved lightly toward inner circumference (130φ vicinity)?</p>	<p>Readjust to regain proper kick-back (0.6) or replace.</p> <p>Clean.</p>
Faulty operation of Hand operated Lifter.	1. Lifter does not operate either when set UP or DOWN.	<p>Faulty adjustment</p> <p>Adjustment Screws (32) and (33) are not working effectively.</p> <p>LEVER ASSY (34) does not operate properly.</p> <p>Is installation screw (35) loose?</p> <p>Is SPRING P (36) misshapen or installation loose?</p> <p>PLATE LIFT (37) installation loose.</p> <p>Installation screw (38) loose.</p>	<p>Re-adjust.</p> <p>Tighten or replace.</p> <p>Tighten to specified position.</p>
	2. Lifter does not operate when set to DOWN position.	<p>Inner part of BEARING LIFTER (39) needs oil. Inferior.</p> <p>Remove LIFTER ASSY and check.</p> <p>NOTE: THERE ARE CASES WHEREIN AFTER HAVING THE LIFTER AT UP POSITION FOR A LONG PERIOD OF TIME, WHEN IT IS FIRST BROUGHT TO DOWN DIRECTION, MOVEMENT IS RELATIVELY SLOW (SOMETIMES STOPS TEMPORARILY), BUT THIS IS NORMAL AND DOES NOT MEAN IT IS OUT OF ORDER.</p>	<p>Replace LIFTER ASSY.</p>
	3. No UP/DOWN moderation when lifter is manipulated (Springs back at UP positions).	<p>Steel ball (42) inside CAM LIFT (40) has come out.</p> <p>Is SPRING (41) damaged or misshapen?</p> <p>Confirm STEEL BALL (42) position.</p> <p>Adjustment faulty</p> <p>Setting of adjustment screws (32) and (33) unsuitable (too tight).</p>	<p>Replace SPRING P.</p> <p>Re-insert steel ball bearing.</p> <p>Readjust.</p>

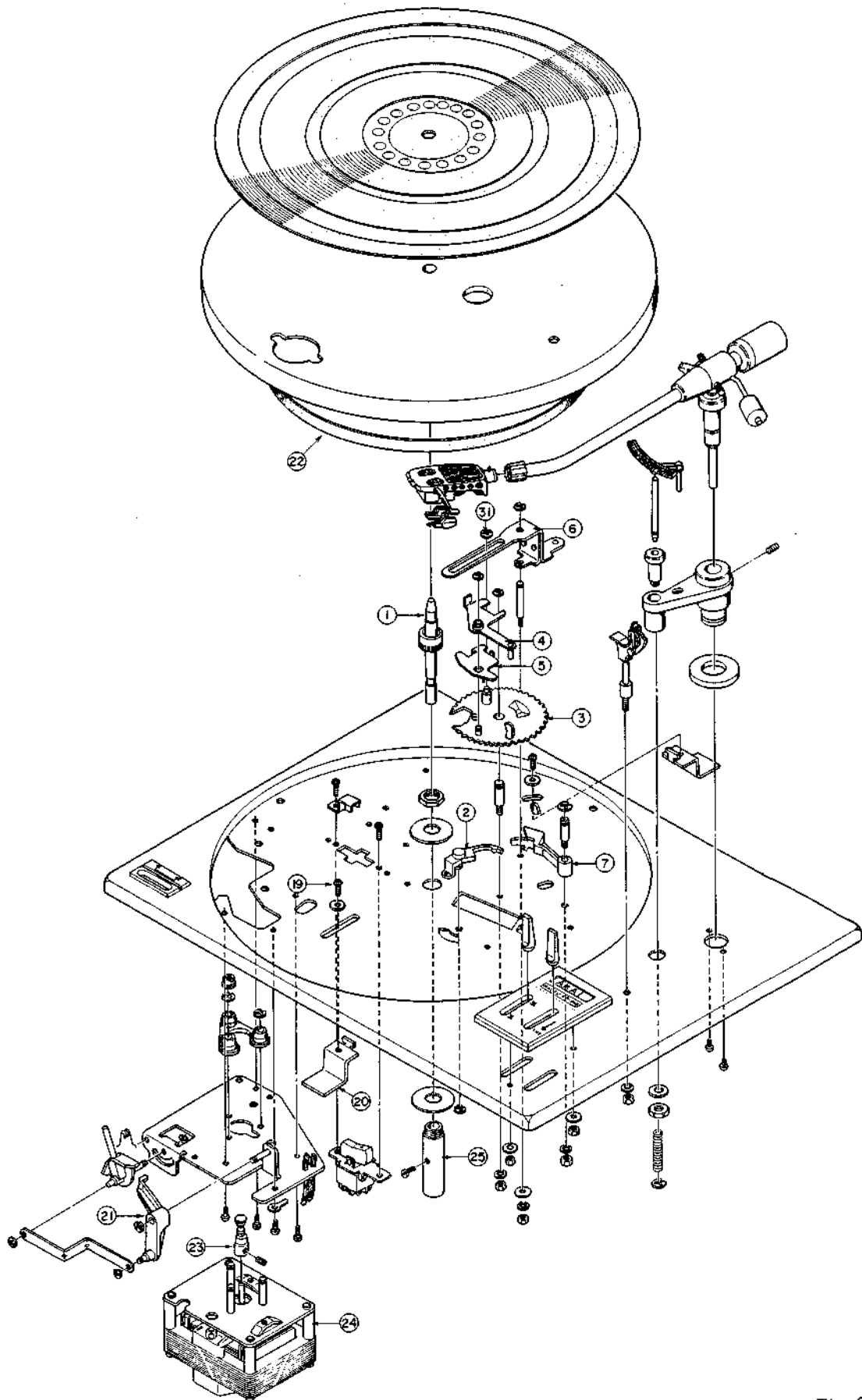

Fig. 20

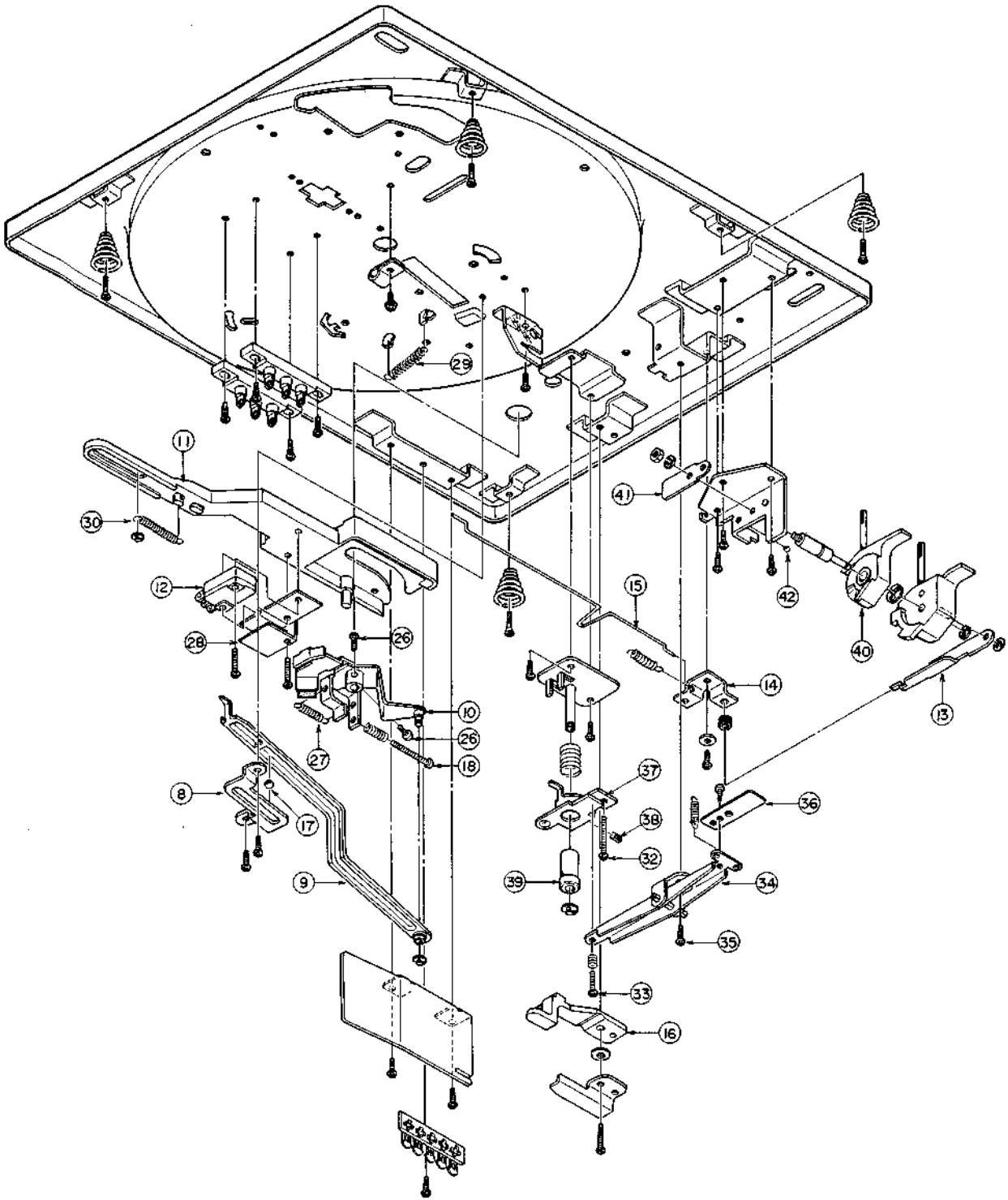

Fig. 21

SECTION 2

PARTS LIST

TABLE OF CONTENTS

FIG. 1	ASSEMBLY BLOCK (1)	34
FIG. 2	ASSEMBLY BLOCK (2)	37
FIG. 3	CASE BLOCK	38
INDEX		39





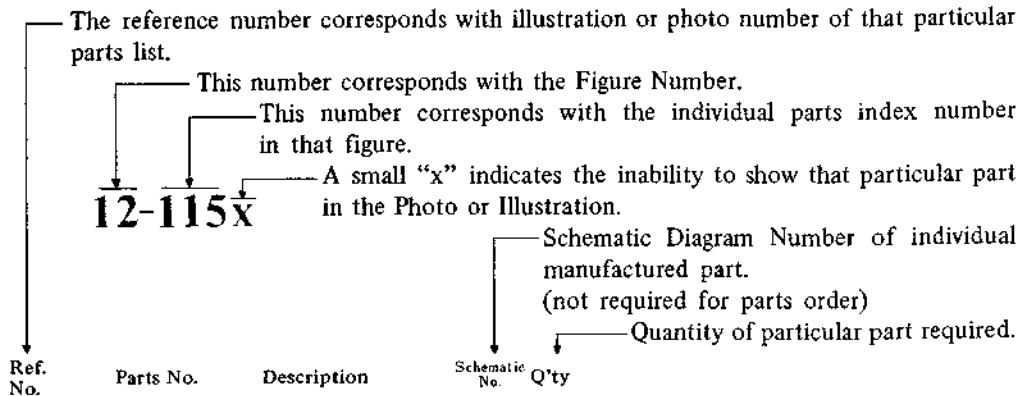













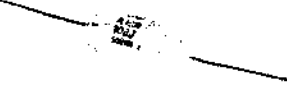

HOW TO USE THIS PARTS LIST

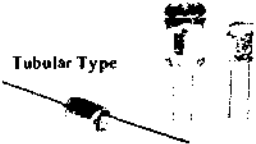
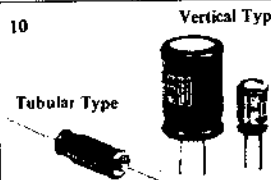
1. This parts list is compiled by various individual blocks based on assembly process.
2. When ordering parts, please describe parts number, serial number, and model number in detail.
3. How to read List

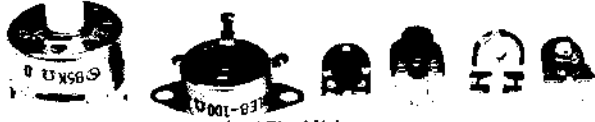

4. The symbol numbers shown on the P.C. Board list can be matched with the Composite Views of Components of the Schematic Diagram or Service Manual.
5. The indications of Resistors and Capacitors in the photos of P.C. Board are being eliminated.
6. The shape of the parts and parts name, etc. can be confirmed by comparing them with the parts shown on the Electrical Parts Table of P.C. Board.
7. Both the kind of part and installation position can be determined by the Parts Number. To determine where a parts number is listed, utilize Parts Index at end of Parts List.
It is necessary first of all to find the Parts Number. This can be accomplished by using the Reference Number listed at right of parts number in the Parts Index. (meaning of ref. no. outlined in Item 3 above).
8. Utilize separate "Price List for Parts" to determine unit price. The most simple method of finding parts Price is to utilize the reference number.

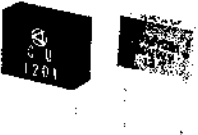
ELECTRICAL PARTS TABLE

<p>Because the indication of resistors and capacitors in the P.C. Board photos are being eliminated, please confirm parts name and shape by comparing them with the parts shown in this table.</p>	<p>1</p>  <p style="text-align: center;">Solid Resistor</p>	<p>2</p> <p style="text-align: right;">Stopper Type</p>  <p style="text-align: center;">Carbon Resistor</p>	<p>3</p>  <p style="text-align: center;">Metal Oxide Film Resistor</p>
<p>4</p>  <p style="text-align: center;">Cement Resistor</p>	<p>5</p>  <p style="text-align: center;">Wire-Wound Resistor</p>	<p>6</p>  <p style="text-align: center;">Thermister</p>	<p>7</p>  <p style="text-align: center;">Enamel Resistor</p>
<p>1</p>  <p style="text-align: center;">MP Capacitor (Tubular Type)</p>	<p>2</p>  <p style="text-align: center;">Plastic Capacitor</p>	<p>3</p>  <p style="text-align: center;">Mylar Capacitor</p>	<p>4</p>  <p style="text-align: center;">VFM (Hi-Q) Capacitor</p>
<p>5</p>  <p style="text-align: center;">Mylar Capacitor</p>	<p>6</p>  <p style="text-align: center;">Tantalum Capacitor</p>	<p>7</p>  <p style="text-align: center;">Oil Capacitor (Tubular Type)</p>	<p>8</p> <p style="text-align: right;">Vertical Type</p>  <p style="text-align: center;">Styrofoam Capacitor</p>
<p>9</p>  <p style="text-align: center;">Electrolytic Capacitor (Tubular Type)</p>	<p>10</p> <p style="text-align: right;">Vertical Type</p>  <p style="text-align: center;">Electrolytic Capacitor</p>	<p>11</p>  <p style="text-align: center;">Ceramic Capacitor</p>	<p>12</p>  <p style="text-align: center;">Metalized Mylar (Paper) Capacitor</p>
<p>13</p>  <p style="text-align: center;">Paper Condenser</p>		<p>VR</p>  <p style="text-align: center;">Semi-Fixed Volume</p>	
<p>L</p>  <p style="text-align: center;">Ferri Inductor</p>	<p>TR</p>  <p style="text-align: center;">Transistor</p>		
<p>CR</p>  <p style="text-align: center;">Spark Quencher</p>	<p>D</p>  <p style="text-align: center;">Diode (Silicon, Zener, Germanium)</p>		

ASSEMBLY BLOCK (1)

Ref. No.	Parts No.	Description	Schematic No.	Q'ty	Ref. No.	Parts No.	Description	Schematic No.	Q'ty
PU ARM BLOCK					1-66	PL715342	Washer (SPC) D10.2x34x0.8t	2270353200	2
1-1	PL715871	PU Arm Comp.	2073170900	1	1-67	PL710414	Special Nut 10M	2079667500	1
1-2	PL715882	Stand Base	2074381000	1	PANEL BLOCK				
1-3	PL715893	PU Stand	2073563500	1	1-68	PL716130	Panel	2071377000	1
1-4	PL711572	Head Shell		1	1-69	PL710256	Washer (SPC) D4.2x11x0.8t	2079164900	2
1-5	PL711617	Special Screw 2.6x11		2	1-70	PL710267	Lock Plate	2074379100	2
1-6x	PL717445	Special Screw 2.6x14		2	1-71	ZS710278	ISO Screw, pan head 4x8		2
1-7x	ZW711652	Special Washer (Nylon) D2.6		2	1-72	PL716141	Control Name Plate	2286527700	1
1-8x	ZW711641	Special Nut 2.6M		2	1-73x	PL716501	Control Name Plate (002D)	2286527600	1
1-9	PL715926	PU Rest Comp.	2073866600	1	1-74	PL710076	Washer (SPC) D3.2x11x0.5t	2079181700	2
1-10	ZW710638	Spring Washer 4M		1	1-75	ZW715498	Nut M3		2
1-11	ZW710640	Nut 4M		1	1-76x	PL710280	Panel Spring A (Right Side)	2070379800	2
1-12	PL715724	Lifter Bar Comp.	2076165200	1	1-77x	PL710302	Panel Spring C (Left Side)	2070380000	2
1-13	PL715746	Lifter Shaft	2076465500	1	1-78x	ZS710324	Tapping Screw #2 3x12 (countersunk)	2270153400	4
1-14	PL715735	Lifter Bearing	2077385100	1	1-79	PL716152	Switch Plate	2074668200	1
1-15	PL715757	Compression Coil Spring	2277165300	1	1-80	ZS552611	ISO Screw, pan head 3x8 (Black)		4
1-16	PL715770	Special Washer D8.2x14x0.4t	2079199900	1	1-81	PL715948	Seesaw Switch	2214638900	1
1-17	PL715768	Special Nut 8M	2079666300	1	1-82	PL715533	Knob	2283540100	2
1-18	ZW710616	'E' Ring 3M		1	SPEED CHANGE DEVICE BLOCK				
1-19	PL710098	Sub Panel	2074379300	1	1-83x	PL711540	Main Weight		1
1-20	BM711674	Motor AC-4-A (110/220)	2212540400	1	1-84x	PL711551	Sub Weight		1
1-21x	BM712102	Motor AC-4-B (240)	2212540500	1	1-85x	PL711562	Lateral Weight		1
1-22x	BM716512	Motor (100)	2212540700	1	MAIN GEAR BLOCK				
1-23	PL710100	Motor Base, w/prop	2074379200	1	1-41	PL715364	Main Gear	2072763300	1
1-24	PL710144	Spacer AL-P	2077377000	4	1-42	PL715386	Clutch Comp.	2075176000	1
1-25	PL710111	Adjust Nut D4	2079668100	1	1-43	PL715397	Trip	2075374000	1
1-26	ZW710346	'E' Ring 4M		2	1-44	ZW710335	'E' Ring 2M		1
1-27	ZS710234	ISO Screw, pan head 4x45		4	1-45	PL710245	Push Nut CS-D3		1
1-28	PL710155	Motor Cushion Rubber	2088178700	1	1-46	PL715375	Gear Shaft	2076462100	1
1-29	PL710122	Belt Guide	2074682100	1	1-47	ZW712080	Spring Washer D3		1
1-30	PL710201	Speed Cam	2075768300	1	1-48	ZW715498	Nut M3		1
1-31	PL710212	Return Spring	2070774000	1	1-49	ZW715500	'E' Ring 3.6M		1
1-32	PL710133	Connector Plate	2075387500	1	1-50	PL715408	Reject Plate A	2075390400	1
1-33	PL710245	Push Nut CS-D3		1	1-51	ZW710346	'E' Ring 4M		1
1-34	ZW710335	'E' Ring 2M		1	1-52	PL715544	Gear Stopper	2075390500	1
1-35	ZW710616	'E' Ring 3M		1	1-53	PL715555	Stopper Shaft	2076382400	1
1-36	ZS710223	Tapping Screw #2 3x8 (BR)		4	1-54	ZW712080	Spring Washer D3		2
1-37	PL710357	Belt	2072861500	1	1-55	ZW715498	Nut M3		2
1-38	PL710177	Motor Pulley (50 Hz)	2071672000	1	1-56	ZW715566	'E' Ring 3.1M		1
1-39x	PL710188	Motor Pulley (60 Hz)	2071672100	1	1-57	PL715588	Crank Lever Comp.	2075177100	1
1-40	PL710190	Speed Name Plate	2077978300	1	1-58	PL715590	Crank Shaft	2076462400	1
TURN TABLE BLOCK					1-59	PL715612	Washer (SPC) D3.2x9.5x0.5t	2079162500	1
1-61	PL715331	Turn Table	2072367400	1	1-60	ZW715601	'E' Ring 2.5M		1
1-62	PL710370	Turn Table Sheet	2072567200	1					
1-63	PL715353	Table Shaft, w/gear	2072567600	1					
1-64	PL710381	Table Bearing	2072563700	1					
1-65	PL710392	Special Screw	2079563000	1					

When ordering parts, please describe Parts Number, Serial Number, and Model Number in detail.

FIG. 1 ILLUSTRATION OF ASSEMBLY BLOCK (1)

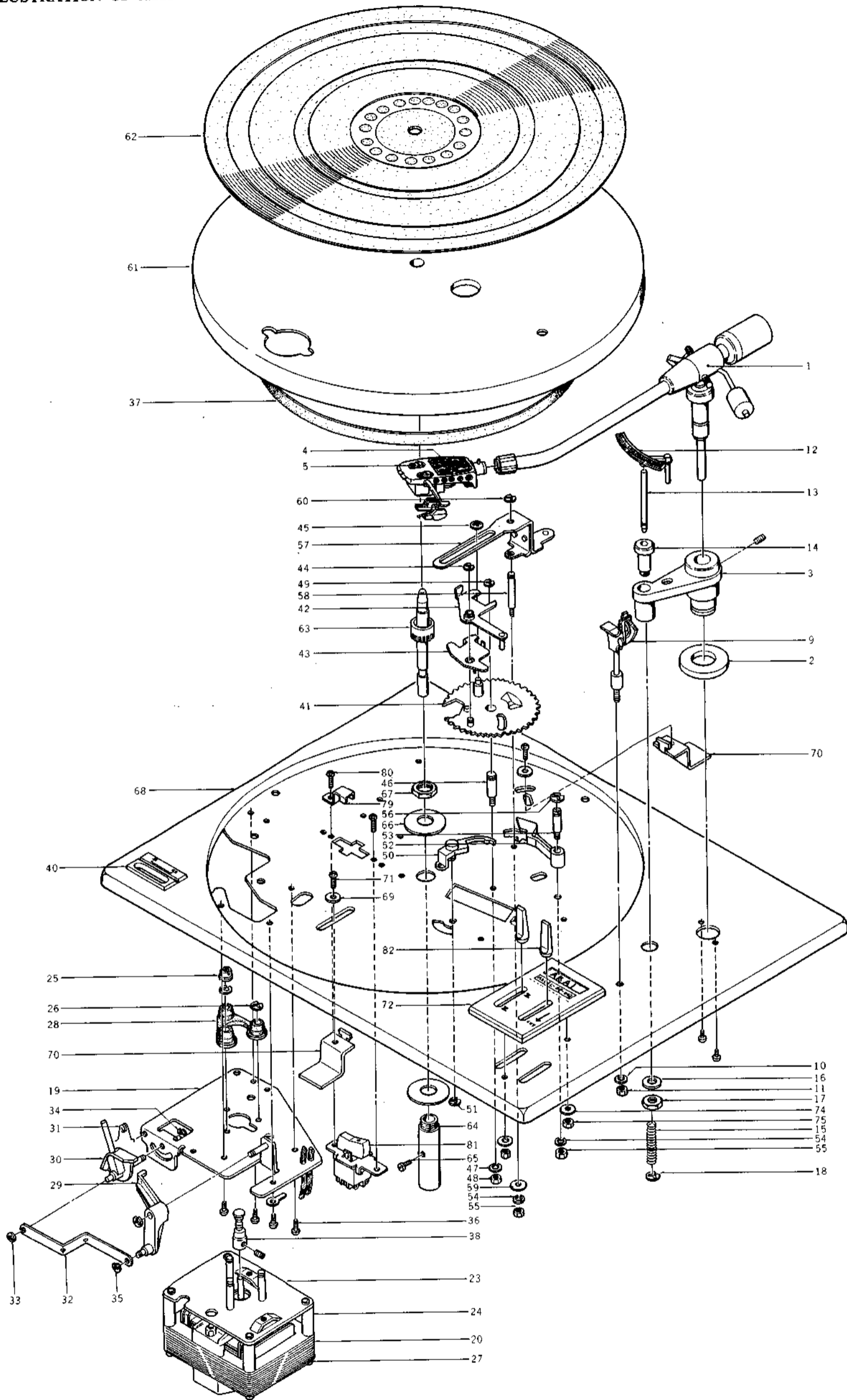
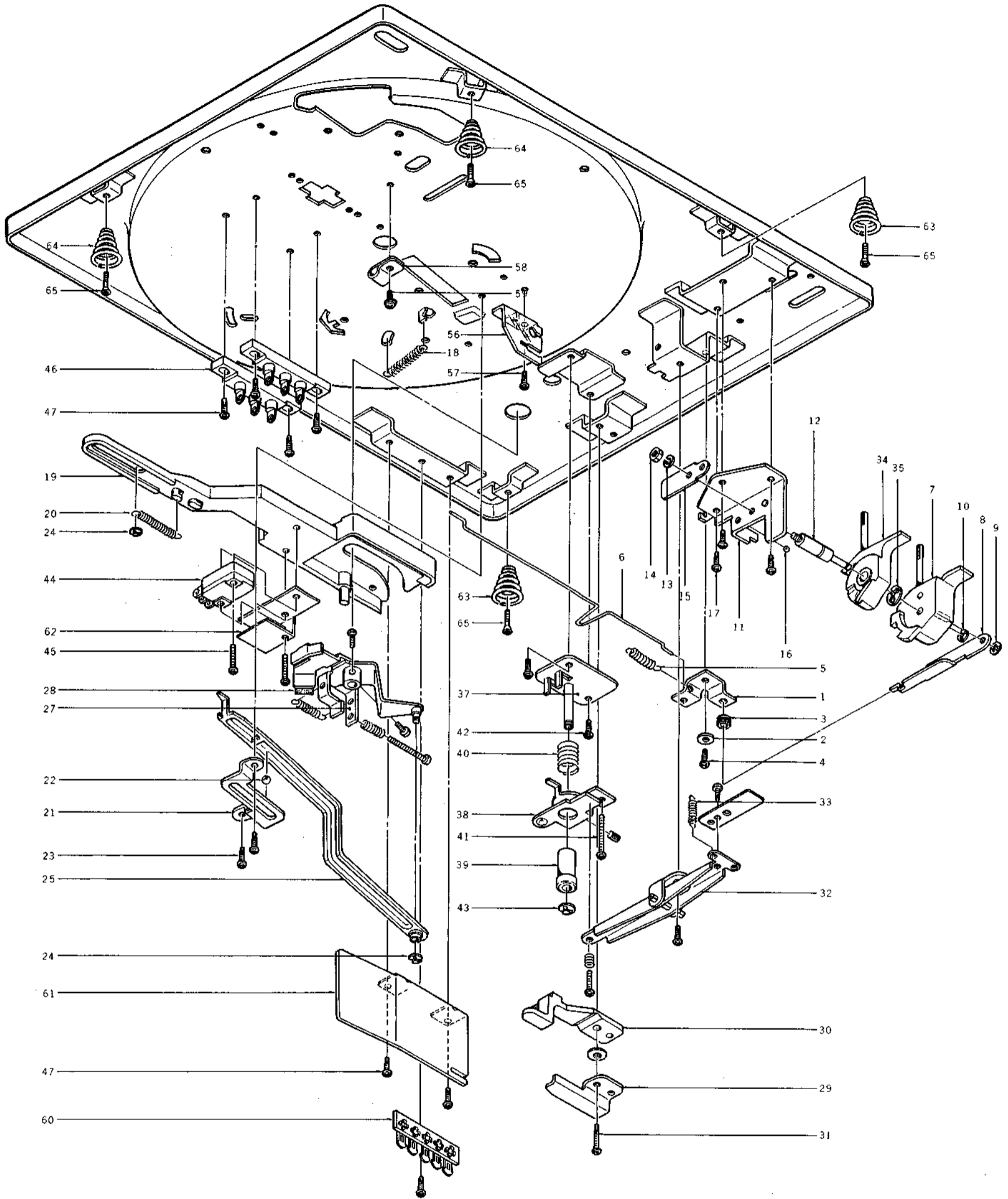

FIG. 2 ILLUSTRATION OF ASSEMBLY BLOCK (2)



ASSEMBLY BLOCK (2)

Ref. No.	Parts No.	Description	Schematic No.	Q'ty
RETURN BLOCK				
2-1	PL715421	Reject Plate B	2075390300	1
2-2	PL715432	Spacer BS-P	2077384600	1
2-3	PL710447	Joint Bush	2088166600	1
2-4	PL715443	Special Screw 3x8	2075914000	1
2-5	PL715465	Pull Spring	2075692000	1
2-6	PL715410	Reject Pole	2076465800	1
2-7	PL715522	Reject Cam	2075768900	1
2-8	PL715454	Joint Plate	2075390800	1
2-9	PL717513	Push Nut CS-D4		1
2-10	ZW710616	'E' Ring 3M		1
2-11	PL715476	Cam Holder	2074683600	1
2-12	PL715487	Cam Shaft	2076465600	1
2-13	ZW710638	Spring Washer D4		1
2-14	ZW710640	Nut M4		1
2-15	PL715511	Plate Spring	2070963900	1
2-16	PL715667	Steel Ball 1/8"		1
2-17	ZS710223	Tapping Screw #2 3x8 (BR)	2079574000	1
2-18	PL715577	Pull Spring	2070560100	1
2-19	PL715623	Return Lever	2075389500	1
2-20	PL715634	Pull Spring	2070571300	1
2-21	PL715645	Ball Holder	2074675400	1
2-22	PL715656	Steel Ball 5/32"		1
2-23	ZS715713	Tapping Screw #2 3x6 (pan)		2
2-24	ZW710335	'E' Ring 2M		2
2-25	PL715678	Auto Lever	2075390600	1
2-26x	PL715680	Washer (Nylon) D3.1x6x0.2t	2079106600	1
2-27	PL715691	PU Plate Comp.	2075177000	1
2-28	PL715702	Cushion	2275672800	1
LIFTER BLOCK				
2-29	PL715781	Lever Stay	2074684900	1
2-30	PL715792	Elevation Plate	2075390200	1
2-31	ZS710471	Tapping Screw #2 3x8 (pan)		2
2-32	PL715803	Lift Lever Comp.	2075390900	1
2-33	PL715814	Pull Spring	2070563400	1
2-34	PL715825	Lift Cam	2075768900	1
2-35	ZW717524	'E' Ring 5M		1
2-36x	PL715533	Knob	2283540100	2
2-37	PL715836	Bracket, w/prop	2074684500	1
2-38	PL715847	Lift Plate	2075391200	1
2-39	PL715858	Lifter Bearing	2077385300	1
2-40	PL715860	Compression Coil Spring	2277165200	1
2-41	ZS717535	ISO Screw, pan head 3x8		1
2-42	ZS715713	Tapping Screw #2 3x6 (pan)		2
2-43	ZW710616	'E' Ring 3M		1
ELECTRIC PARTS BLOCK				
2-44	PL715937	Mini SW, w/lead wire	2214585400	1
2-45	ZS716196	Tapping Screw #2 2.6x16		2
2-46	PL715950	Terminal 3P	2216130200	2
2-47	ZS710223	Tapping Screw #2 3x8 (BR)	2079574000	6
2-48x	PL716207	Mylar/C. 0.047µF 100OVV		1
2-49x	PL715961	Output Terminal	2216204900	1
2-50x	PL711966	Fuse 1A 250V	2214422400	1
2-51x	EW711955	AC Cord (U/L) 2.5M	2217619900	1
2-52x	EW711990	AC Cord (3 core) 2.5M	2217705100	1
2-53x	EW716545	AC Cord (J) 2.5M	2217643600	1
2-54x	PL712001	Cord Stopper (U/L)	2088167600	1
2-55x	PL712012	Cord Stopper (3 core)	2218512600	1
2-56	PL715972	Shaft Holder	2074672800	1
2-57	ZS710471	Tapping Screw #2 3x8 (pan)		2
2-58	PL712067	Cord Cramp	2218414800	1
2-59	ZS712091	Tapping Screw #2 3x8 (BR) w/washer	2079591600	1
2-60	PL716016	Lug Plate 1L4P	2216105700	1
2-61	PL716027	Barrier (L)	2274856000	1
2-62	PL716038	Barrier (S)	2274858200	1
2-63	PL710280	Panel Spring A (Right Side)	2070379800	2
2-64	PL710302	Panel Spring C (Left Side)	2070380000	2
2-65	ZS710324	Tapping Screw #2 3x12 (countersunk) 2270153400		4

When ordering parts, please describe Parts Number, Serial Number, and Model Number in detail.

FIG. 3 PHOTO OF CASE BLOCK

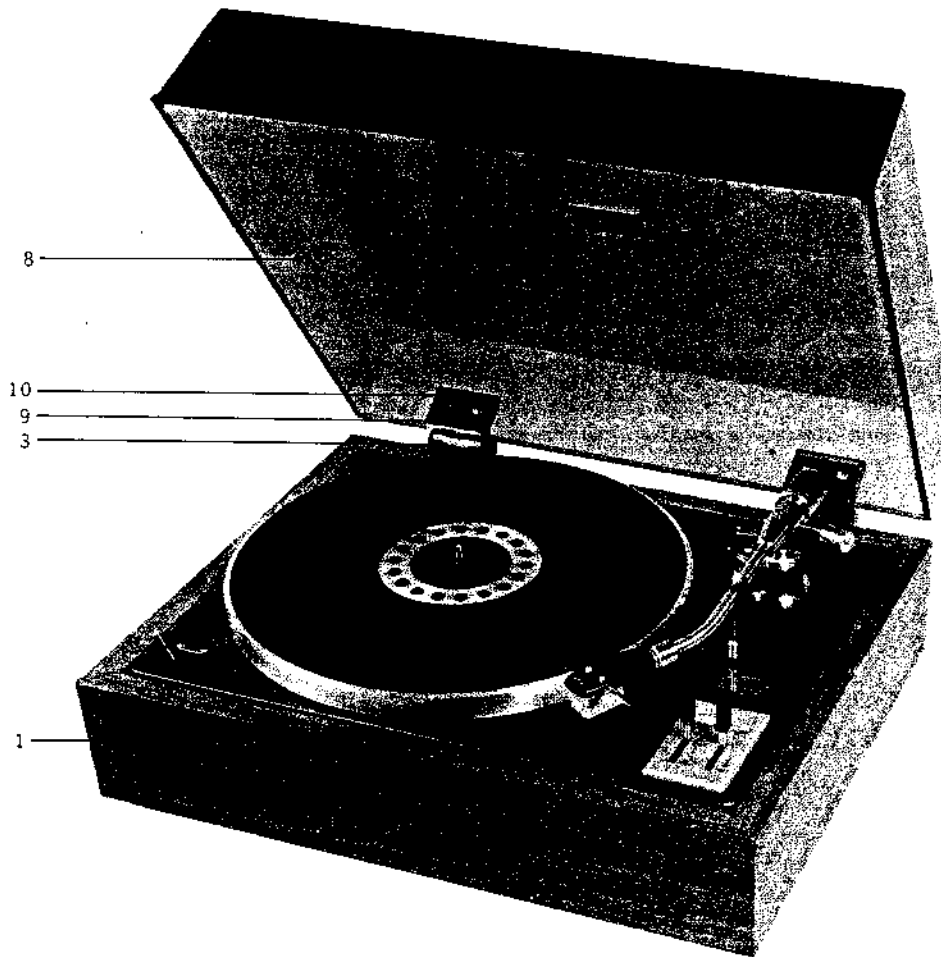

CASE BLOCK

Ref. No.	Parts No.	Description	Schematic No.	Q'ty
3-1	PL716040	Cabinet	2084768100	1
3-2x	PL716556	Cabinet (002D)	2084768500	1
3-3	PL710987	Hinge A	2086164600	2
3-4x	PL711011	Cord Support	2074679000	1
3-5x	PL711022	Cord Support	2074682600	1
3-6x	ZS710965	Wood Screw, round head		
			3.1x13	8
3-7x	PL711044	Cushion (Foot)	2086360500	4
3-8	PL710976	Dust Cover	2084766800	1
3-9	PL710998	Hinge B	2075378800	2
3-10	ZS711000	Screw, oval countersunk head		
			4x10	4

When ordering parts, please describe Parts Number, Serial Number, and Model Number in detail.

INDEX

Parts No.	Ref. No.	Parts No.	Ref. No.	Parts No.	Ref. No.	Parts No.	Ref. No.	Parts No.	Ref. No.
BM711674	1-20	PL715680	2-26x						
BM712102	1-21x	PL715691	2-27						
BM716512	1-22x	PL715702	2-28						
EW711955	2-51x	PL715724	1-12						
EW711990	2-52x	PL715735	1-14						
EW716545	2-53x	PL715746	1-13						
PL710076	1-74	PL715757	1-15						
PL710098	1-19	PL715768	1-17						
PL710100	1-23	PL715770	1-16						
PL710111	1-25	PL715781	2-29						
PL710122	1-29	PL715792	2-30						
PL710133	1-32	PL715803	2-32						
PL710144	1-24	PL715814	2-33						
PL710155	1-28	PL715825	2-34						
PL710177	1-38	PL715836	2-37						
PL710188	1-39x	PL715847	2-38						
PL710190	1-40	PL715858	2-39						
PL710201	1-30	PL715860	2-40						
PL710212	1-31	PL715871	1-1						
PL710245	1-33	PL715882	1-2						
PL710245	1-45	PL715893	1-3						
PL710256	1-69	PL715926	1-9						
PL710267	1-70	PL715937	2-44						
PL710280	1-76x	PL715948	1-81						
PL710280	2-63	PL715950	2-46						
PL710302	1-77x	PL715961	2-49x						
PL710302	2-64	PL715972	2-56						
PL710357	1-37	PL716016	2-60						
PL710370	1-62	PL716027	2-61						
PL710381	1-64	PL716038	2-62						
PL710392	1-65	PL716040	3-1						
PL710414	1-67	PL716130	1-68						
PL710447	2-3	PL716141	1-72						
PL710976	3-8	PL716152	1-79						
PL710987	3-3	PL716207	2-48x						
PL710998	3-9	PL716501	1-73x						
PL711011	3-4x	PL716556	3-2x						
PL711022	3-5x	PL717445	1-6x						
PL711044	3-7x	PL717513	2-9						
PL711540	1-83x	ZS552611	1-80						
PL711551	1-84x	ZS710223	1-36						
PL711562	1-85x	ZS710223	2-17						
PL711572	1-4	ZS710223	2-47						
PL711617	1-5	ZS710234	1-27						
PL711966	2-50x	ZS710278	1-71						
PL712001	2-54x	ZS710324	1-78x						
PL712012	2-55x	ZS710324	2-65						
PL712067	2-58	ZS710471	2-31						
PL715331	1-61	ZS710471	2-57						
PL715342	1-66	ZS710965	3-6x						
PL715353	1-63	ZS711000	3-10						
PL715364	1-41	ZS712091	2-59						
PL715375	1-46	ZS715713	2-23						
PL715386	1-42	ZS715713	2-42						
PL715397	1-43	ZS716196	2-45						
PL715408	1-50	ZS717535	2-41						
PL715410	2-6	ZW710335	1-34						
PL715421	2-1	ZW710335	1-44						
PL715432	2-2	ZW710335	2-24						
PL715443	2-4	ZW710346	1-26						
PL715454	2-8	ZW710346	1-51						
PL715465	2-5	ZW710616	1-18						
PL715476	2-11	ZW710616	1-35						
PL715487	2-12	ZW710616	2-10						
PL715511	2-15	ZW710616	2-43						
PL715522	2-7	ZW710638	1-10						
PL715533	1-82	ZW710638	2-13						
PL715533	2-36x	ZW710640	1-11						
PL715544	1-52	ZW710640	2-14						
PL715555	1-53	ZW711641	1-8x						
PL715577	2-18	ZW711652	1-7x						
PL715588	1-57	ZW712080	1-47						
PL715590	1-58	ZW712080	1-54						
PL715612	1-59	ZW715498	1-48						
PL715623	2-19	ZW715498	1-55						
PL715634	2-20	ZW715498	1-75						
PL715645	2-21	ZW715500	1-49						
PL715656	2-22	ZW715566	1-56						
PL715667	2-16	ZW715601	1-60						
PL715678	2-25	ZW717524	2-35						

A AKAI ELECTRIC CO., LTD.
AKAI TRADING CO., LTD.

(P.O. BOX 21, Tokyo International Airport, Japan)
12-14, 2-chome, Higashi-Kojiya, Ohta-ku, Tokyo, Japan

TELEPHONE: TOKYO (742) 5 1 1 1

CABLE: HIFI AKAI TOKYO TELEX: J26281

Printed No. 1481242 Printed in Japan Price \$6.00