

# AKAI SERVICE MANUAL

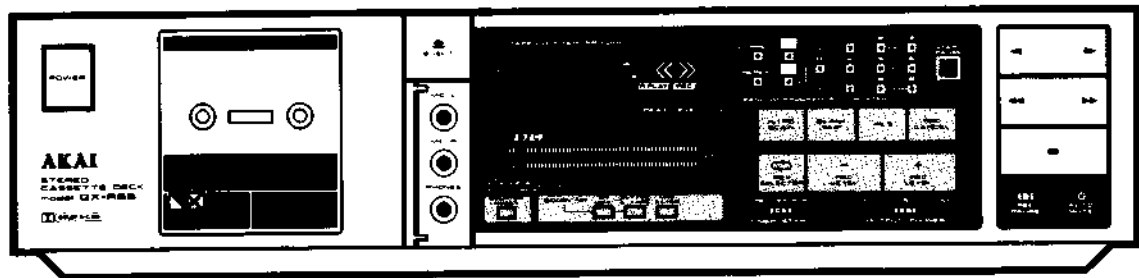

STEREO CASSETTE DECK

MODEL **GX-R55**

## ABBREVIATIONS FOR SERVICE MANUAL MODEL GX-R55

ABBREVIATIONS	EXPLANATION
AC	Alternating Current
ADJ	ADJustment
BSP	Blank Skip Play
DC	Direct Current
EQ	EQualizer
FF (operation)	Fast Forward
FF (logic)	Flip Flop
FLD	FLuorescent Display
FREQ	FREQuency
FWD	ForWarD
INH	INHibit
IPLS	Instant Program Locating System
MPX	Multi PleX
NR	Noise Reduction
PB	Play Back
REC	RECORD
REV	REVerse
REW	REWind
SENS	SENSitivity
VR	Variable Resistor
V. REG	Voltage REGulator

# AKAI

## WERKSTATTHANDBUCH

Da dieses Wartungshandbuch bereits auf Englisch veröffentlicht ist und Einstell- und Zeichnungshinweise auf Deutsch enthält, empfiehlt es sich, diese Ausgabe des Handbuchs zusammen mit der bereits veröffentlichten englischen Ausgabe und den Stromlaufplänen zu verwenden.

### STEREOCASSETTENDECK

### MODEL GX - R55

#### I. TECHNISCHE DATEN

SPURSYSTEM ..... 4-Spur 2-Kanal-Stereosystem  
CASSETTE ..... Philips-Kompaktcassette  
TONKÖPFE ..... Ein Loschkopf  
Twin field super GX Kopf  
für Aufnahme und Wiedergabe  
MOTOREN ..... 1 elektronisch gesteuerter  
Gleichstrommotor für den  
Capstantrieb  
1 Gleichstrommotor für das  
Kurvenrad  
GLEICHLAUF-SCHWANKUNGEN .... ±0,07% W.peak (EIAJ)  
0,05% (W RMS)  
0,12% (DIN)  
FREQUENZGANG ..... Normal:  
20 bis 17.000Hz ±3dB (EIAJ)  
CrO<sub>2</sub>:  
20 bis 18.000Hz ±3dB (EIAJ)  
Reineisenband:  
20 bis 19.000Hz ±3dB (EIAJ)  
GERÄUSCHSPANNUNG ..... 60dB  
56dB (EIAJ)  
Dolby B ON:  
Verbesserung um bis zu 5dB  
bei 1kHz, 10dB über 5kHz  
Dolby C ON:  
Verbesserung um bis zu 15dB  
bei 500kHz, 20dB bei 1kHz  
bis 10kHz

KLIRRFAKTOR ..... 0,65% (Reineisenband)  
0,55% (Reineisenband)  
0,25% (CrO<sub>2</sub>)  
0,15% (Normal)  
EINGANG ..... LINE: 410mV/47kΩ  
100V, 50/60Hz für Japan  
LEISTUNGS-AUFNAHME ..... LINE: 410mV/1kΩ  
120V, 60Hz für USA und Kanada  
220V, 50Hz für Europa außer GB  
240V, 50Hz für GB und  
Australien  
110V/120V/220V/240V, 50/60 Hz  
umschaltbar für andere Länder  
ABMESSUNGEN ..... 440(B) x 105(H) x 288(T) mm  
GEWICHT ..... 5,0kg

- \* Änderungen von technischen Daten und Design zwecks Verbesserung vorbehalten.
- \* Das Rauschunterdrückungs-System wird unter Lizenz von Dolby Laboratories Licensing Corporation gefertigt. "Dolby" und das Double-D-Zeichen sind Warenzeichen von Dolby Laboratories Licensing Corporation.
- \* "dbx" ist ein Warenzeichen von dbx Incorporated.

## II. SICHERHEITSANWEISUNG

### SICHERHEITSPRÜFUNG NACH DER REPARATUR

Überprüfen Sie, ob der Isolationswiderstand zwischen den Stiften des Netzsteckers sowie allen äußeren Teilen des Gerätes über 10 MOhm liegt. Bei Geräten mit Anschluß von Außenantenne (Tuner, Empfänger usw.), welche für [C] oder [A] bestimmt sind, muß der Isolationswiderstand über 2,2 MOhm liegen (Masse-Anschlüsse, Mikrofonbuchsen, Kopfhörerbuchsen, line-in/out-Buchsen usw.)

### VORSICHTSMASSNAHMEN BEI DER REPARATUR

1. Die mit dem  $\Delta$  Symbol bezeichneten Teile sind ausschlaggebend für die Betriebssicherheit. Diese Teile nur gegen Original Ersatzteile austauschen.
2. Zusätzlich werden andere Teile entsprechend den Gesetzen zur Funkentstörung verwendet. Diese dürfen nur gegen die vorgeschriebenen Bauteile ausgetauscht werden.  
Beispiele: HF-Wandler, Tuner-Komponenten, Antennen-Wahlschalter, HF-Kabel, Entstörkondensatoren, Entstörfilter usw.
3. Nur die vorgeschriebene interne Verdrahtung verwenden. Hierbei besonders beachten:
  - 1) Mit PVC-Umhüllung versehene Leitungen.
  - 2) Doppelt isolierte Leitungen.
  - 3) Hochspannungsleitungen
4. Für gefährliche, stromführende Teile die vorgeschriebenen Isoliermaterialien verwenden. Hierbei besonders beachten:
  - 1) Isolierband
  - 2) PVC-Umhüllung
  - 3) Abstandshalter
  - 4) Isolierscheiben für Transistoren
  - 5) Plastikschrauben zum Anbringen von Mikroschaltern (speziell bei Plattenspielern)
5. Beim Austausch von Bauteilen auf der Primärseite (Transformatoren, Netzkabel, Entstörkondensatoren usw.) Sind die Leitungsenden vor dem Löten fest zu umwickeln.

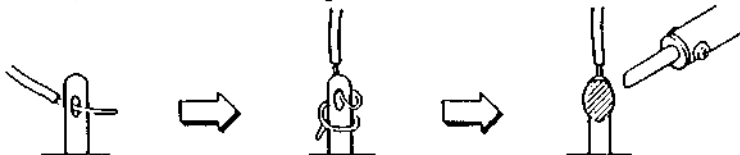

6. Es ist darauf zu achten, daß Leitungen nicht in Kontakt mit Wärme erzeugenden Teilen kommen (Kühlkörper, Oxidmetallschichtwiderstände, Sicherungswiderstände usw.)
7. Überprüfen, dass die ausgetauschten Leitungen nicht in Kontakt mit scharfen Kanten oder spitzen Teilen kommen.
8. Degg. sind die Bereiche in der Umgebung von Stellen, an denen repariert wurde, zu überprüfen.
9. Darauf achten, daß keine Fremdkörper (Schrauben, Lot, usw.) im Gerät verbleiben.

## III. GERÄT VERBLEIBEN

### 3-1 WAHL DER SPANNUNG

Die Geräte für Kanada, USA, Europa, GB und Australien sind nicht mit dieser Funktion ausgestattet. Jedes Gerät ist ab Werk dem Bestimmungsland entsprechend eingestellt; einige Geräte können jedoch nach Bedarf auf 110V, 120V, 220V oder 240V eingestellt werden. Im Falle, daß die Spannung des Gerätes einstellbar ist:

1. Vor dem Anschluß des Netzkabels den an der Rückseite befindlichen.
2. Spannungswähler (VOLTAGE SELECTOR) mit einem Schraubenzieher drehen, so daß die korrekte Spannung angezeigt wird.

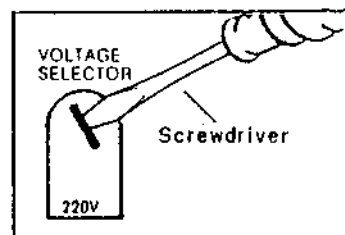

### 3-1-1 WECHSELSTROMFREQÜENZ-UMSCHALTUNG

Eine Wechselstromfrequenz-Umschaltung ist nicht erforderlich, da für das GX-R55 Gleichstrommotoren verwendet werden.

## V. MECHANISCHE EINSTELLUNG

### 5-1 MESSEN DES ANDRUCKROLLENDRUCKS (siehe Abbildung 5-1)



Abb. 5-1

Das Gerät auf FWD PLAY schalten. Die Andruckrollenwelle mit der Federwaage so herunterdrücken, daß ein Abstand von 1-2 mm zwischen Andruckrolle und Capstan entsteht. Anschließend den Druck vermindern, bis sich die Andruckrolle wieder zu drehen

beginnt. In diesem Zustand den Wert ablesen. Der vorgeschriebene Druck beträgt 270 bis 370 g. Fall dieser Wert nicht erreicht wird, ist die Andruckrollenfeder auszutauschen. Die gleiche Verfahrensweise für die Reverseseite anwenden.

### 5-2 WICKEL-DREHMOMENT-MESSUNGEN IN ALLEN BETRIEBSARTEN (siehe Abbildung 5-2)

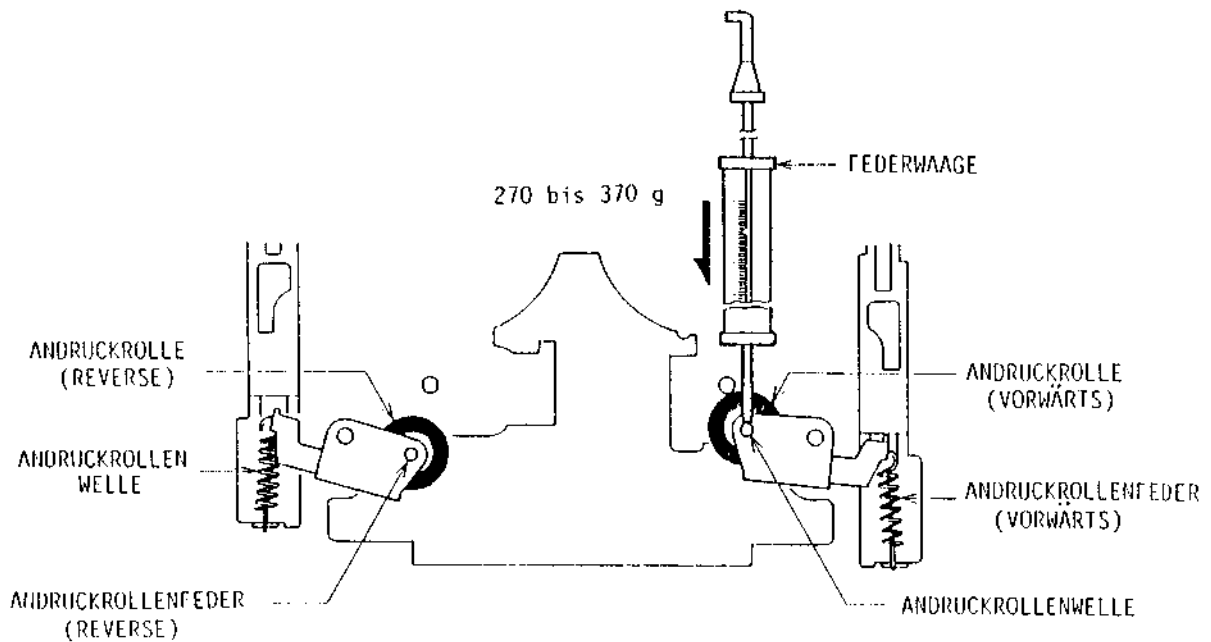

Abb. 5-2

Eine Drehmoment-Meßkassette (AJ-751179) einlegen und die Messung in allen Betriebsarten durchführen.

Für schnellen Vor- und Rücklauf führt man die Messung nach Stoppen des Bandlauf am Bandende durch.

Vorwärts- oder Reverse-Betriebsart

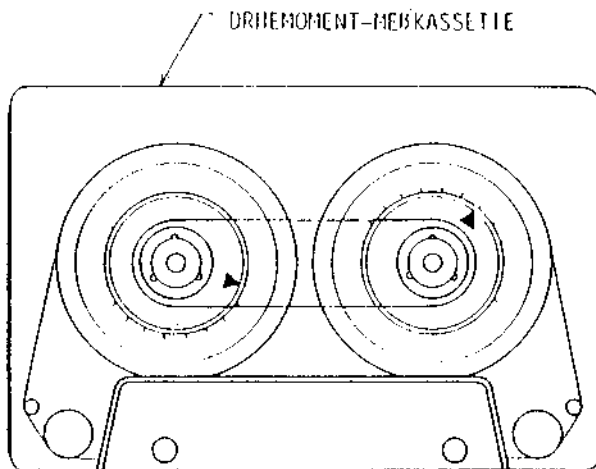
Aufwickelzug: 25 bis 45 g-cm

Abwickelzug: 2 bis 5 g-cm

Schnellvorlauf- oder Rückspul-Betriebsart

Aufwickel: 70 bis 150 g-cm

### 5-3 EINSTELLUNG DER BANDGESCHWINDIGKEIT (siehe Abbildung 5-3)



Abb. 5-3 Position des Regelwiderstandes zur Einstellung der Bandgeschwindigkeit

Einen Frequenzzähler an den Line-Ausgang anschließen. Eine mit einem 1000Hz-Signal bespielte Testcassette (AT7750744) oder eine mit 3150Hz bespielte Testcassette (AT-751263) wiedergeben und den Regelwiderstand zur Einstellung der Bandgeschwindigkeit so einstellen (siehe Abb. 5-3), daß eine Frequenz von  $1000 \pm 3$  Hz bzw.  $3150 \pm 10$  Hz erzielt wird.

# VI. ZUR TONKOPFEINSTELLUNG

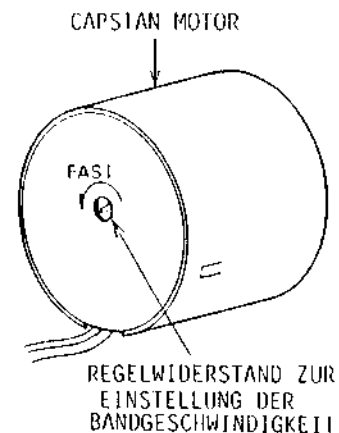

Abb. 6-1



Abb. 6-2

Abb. 6-3 Tonkopfvorsprung-Messgerät (TF-111C)

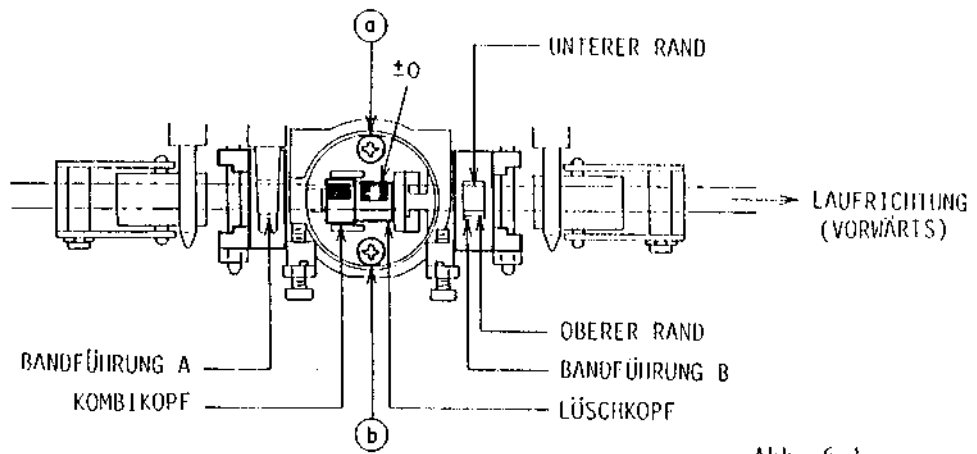
Abb. 6-4 Spiegelschleife (MC-112C)

## 6-1 BANDFÜHRUNGS-EINSTELLUNG (Siehe Abbildung 6-1 und 6-4)

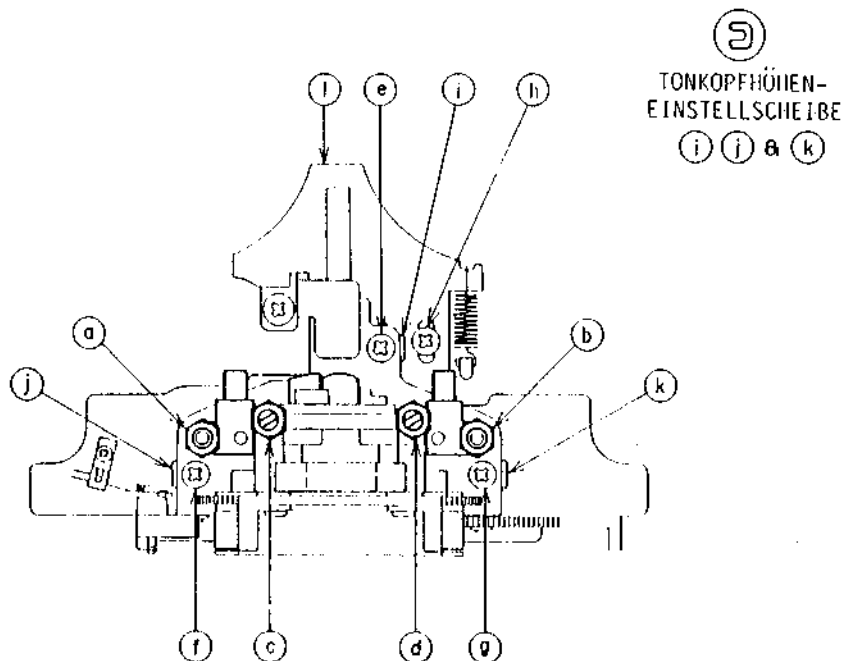
- 1) Wie in Abbildung 6-3 gezeigt, eine Spiegelkassette (AT-751178) verwenden, um den Tonkopfbereich besser einsehen zu können und das Gerät auf Wiedergabe schalten.
- 2) Die Bandführungen (A) + (B) sind mit Hilfe der beiden Einstellmutter (a) + (b), wie in Abb. 6-2 gezeigt, so einzustellen, daß das Band glatt über den unteren Rand beider Bandführungen läuft und keinerlei Verformungen aufweist.

## 6-2 KOMBIKOPF-AZIMUTH-EINSTELLUNG

Eine 10kHz-Tonkopf-Azimuth-Einstellkassette (AT-750778) wiedergeben und die Schrauben (c) (FWD-Richtung) und (d) (REV-Richtung) so einstellen, daß die Pegel beider Kanäle Maximum sind.

(HINWEIS: Die schrauben nicht zu weit drehen, da andere (falsche) Maximalwerte weiter entfernt auf beiden Seiten der korrekten Positionen auftreten.

## 6-3 EINSTELLUNG DER TONKOPFHÖHE

Diese Einstellung ist nicht erforderlich da das GX-R55 mit einem rotierenden Kopfsystem (mit Löschkopf REC/PB-Kombikopf) ausgestattet ist. Eine Überprüfung auf korrekte Kopfhöhe ist jedoch erforderlich und wird wie folgt ausgeführt.

- 1) Zunächst wie im Abschnitt 6-2 beschrieben, den Azimuth überprüfen.
- 2) Eine 315Hz (oder 333Hz) Wiedergabepiegel-Abgleichkassette (AT-750773) in der FWD Wiedergabe-Betriebsart abspielen und den Wiedergabepiegel-Einstellwiderstand (VR5 auf der Vorverstärker-Leiterplatte) so einstellen, daß der LINE OUT Pegel des linken Kanals  $-5,5\text{dBm}$  beträgt. Danach den Pegel des gleichen Kanals in der REV-Betriebsart überprüfen. Die Pegeldifferenz zwischen den Betriebsarten FWD und REV sollte innerhalb  $\pm 1\text{dBm}$  liegen ( $-4,5\text{dBm}$  bis  $-6,5\text{dBm}$ ).
- 3) Wenn im obigen Abschnitt 2 die Differenz mehr als  $\pm 1\text{dBm}$  beträgt, nimmt man die Einstellung der Bandführungen A und B durch Drehen der Bandführungshöhen-Einstellschrauben (a) und (b) vor, die man in der gleichen Richtung um jeweils  $1/4$  Umdrehungen ( $\pm 0,1\text{mm}$ ) dreht, so daß die Differenz innerhalb  $\pm 1\text{dBm}$  liegt.

- 4) Wenn die Differenz durch die obige Einstellung sich nicht korrigieren läßt, ist eine Einstellung der Kopfhöhe erforderlich. Diese kann durch Veränderung der kopfhöhen-Einstellscheiben (i), (j) und (k) vorgenommen werden. (Die Dicke dieser Scheiben ist (i) =  $0,45\text{mm}$ , (j) und (k) =  $0,3\text{mm}$ ). Für den Scheibenaustausch die Schrauben (e), (f) und (g) lösen. Wenn der Pegel in der REV-Betriebsart niedriger ist, bedeutet dies, daß der Kopf zu hoch ist, daher sind in diesem Falle die Unterlegscheiben gegen dünnere auszutauschen. Wenn der Pegel in der REV-Betriebsart höher ist, nimmt man den Austausch gegen dickere vor. Nach dem Austausch der Unterlegscheiben nimmt man die gleiche Einstellung wie im Abschnitt 1 vor und stellt sicher, daß der LINE OUT Pegel  $-5,5\text{dBm} \pm 1\text{dBm}$  beträgt. Zur weiteren Kontrolle ist ein 4-Spur-Kopfhöhen-Einstellband (1kHz/4-Spur AT-750775) abzuspielen. Der Line Ausgangspegel beider Kanäle sollte mehr als  $-8\text{dBm}$  betragen und die Differenz im Pegel zwischen den Betriebsarten FWD und REV sollte innerhalb  $\pm 1\text{dBm}$  liegen. Anderenfalls ist ein Feinabgleich in der gleichen Weise wie in den Abschnitten 3 und 4 auszuführen.
- 5) Ein evtl. erforderlicher Kopfaustausch wird leicht gemacht, indem man nur die Schrauben (a) und (b) in Abbildung 6-1 löst.

## 6-4 KOPFBLOCKVORSPRUNG-EINSTELLUNG (siehe Abb. 6-2 und 6-3)

Eine Tonkopfvorsprung-Messkassette (AT-751180) verwenden und die Betriebsart EWD oder REV Wiedergabe wählen.

Die Schraube (h) lösen und das Kopfträger-Chassis so einstellen, daß das Meßgerät  $3,4 \pm 0,15\text{mm}$  anzeigt.

Nach der Einstellung die Schraube (i) mit Siegelack sichern.

# VII. ELEKTRISCHER ABGLEICH

## 7-1 ABGLEICH DER QUICK-REVERSE-EMPFINDLICHKEIT



Abb. 7-1 GX-R55 Abgleich reverse-Empfindlichkeit



Abb. 7-2

- 1) Durch Entnahme des Bandes aus einer weißen Testcassette eine bandlose Cassette herstellen.
- 2) Ein Digitalvoltmeter zwischen TP-1 und Masse anschließen.
- 3) Unter Verwendung der bandlosen Cassette den Regelwiderstan VR1 so abgleichen, daß das Digitalvoltmeter in der FWD Widergabe  $14V \pm 0,5V$  Gleichspannung anzeigt.
- 4) Werden die erwähnten 14V nicht erreicht, ist der Widerstand R18 (150k ohm) auf der Systemsteuer-Leiterplatte auszubauen und der Regelwiderstand VR1 nochmals in der gleichen Weise wie im Abschnitt abzugleichen.

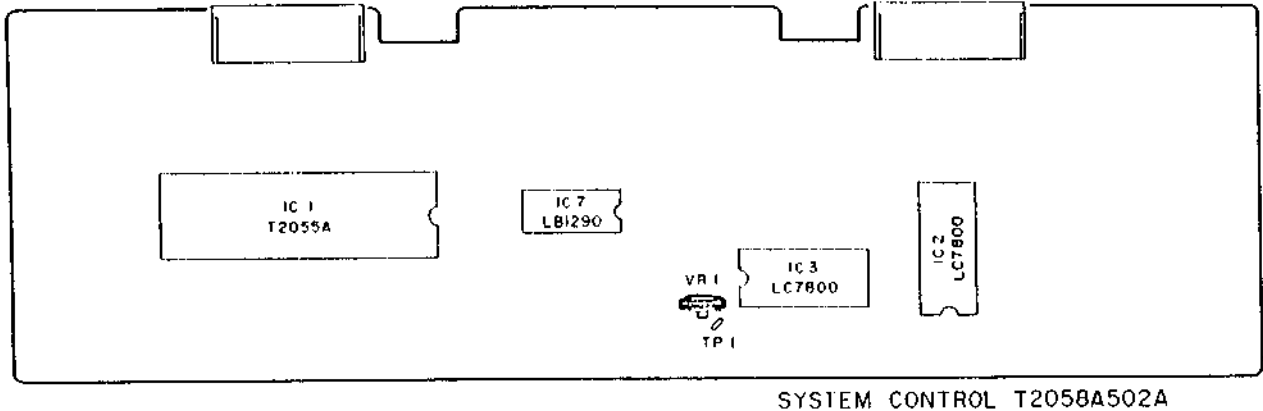
HINWEIS: Vor diesem Abgleich den Bezugsstift und die Bandführung für Transparentbänderkennung reinigen (siehe Abb. 7-2)

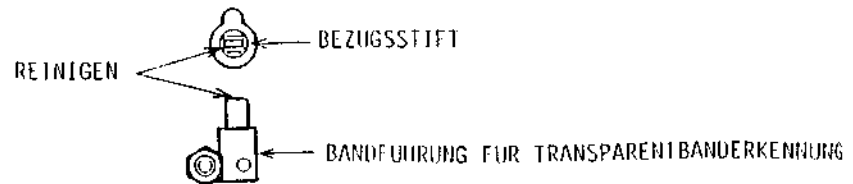

7-2 ABGLEICH DER VORVERSTÄRKER-LEITERPLATTE



Abb. 7-3 CX-R55 Abgleichpunkte an der Vorverstärker-Leiterplatte

Schritt	Abgleichgegenstand	Testcassette und angelegtes signal	Betriebsart	Abgleichteil	Ergebnis	Bemerkungen
1	FWD PB Pegel	333Hz (AT-750773) oder 315Hz (AT-750773)	FWD PB	VR5	$-6,1 \pm 0,2$ dBm oder $-5,5 \pm 0,2$ dBm	
2	REV PB Pegel	333Hz (AT-750773) oder 315Hz (AT-750773)	REV PB		$-6,1 \pm 0,2$ dBm oder $-5,5 \pm 0,2$ dBm	Prüfung
3	FWD PB EQ	10kHz-15dB (AT-750778)	FWD PB	VR4	$-20,5 \pm 0,5$ dBm	
4	REV PB EQ	10kHz-15dB (AT-750778)	REV PB		$-20,5 \pm 0,5$ dBm	Prüfung
5	BIAS OSC FREQ	Kein Signaleingang	REC	T1	$100\text{kHz} \pm 0,5\text{kHz}$	
6	Frequenzgang Normalposition	Normal-Leercassette 1kHz, 10kHz -25,5dBm	REC/PB	VR7	1kHz, 10kHz Linear $\pm 0,3$ dB	
7	Frequenzgang CrO <sub>2</sub> -Position	CrO <sub>2</sub> -Leercassette 1kHz, 10kHz -25,5dBm	REC/PB	VR3	1kHz, 10kHz Linear $\pm 0,8$ dB	
8	Frequenzgang Reineisenband- Position	Reineisenband- Leercassette 1kHz, 10kHz -25,5dBm	REC/PB	VR2	1kHz, 10kHz Linear $\pm 0,8$ dBm	
9	REC Pegel	Normalband- Leercassette 1kHz, -5,5dBm	REC/PB	VR1	$-5,5 \pm 0,5$ dBm	
10	Vormagnet- isierungs- filter	Kein Signaleingang	REC	FL1	Minimumausgang	Aussteuerungsregler auf Maximum stellen
11	Anzeige empfindlichkeit	1kHz Eingang	REC PAUSE	VR6	Ovu Anzeige bei Line Ausgang $-5,9 \pm 0,2$ dBm	Zu diesem Zeitpunkt den Line Ausgangs- pegel um 0,1dB senken und prüfen, daß die OvU Anzeige erlischt.
12	MPX-Filter	19kHz vom Oszillator	REC	FL2	Minimumausgang	MPX-Filter Schalter "ON"

- HINWEIS:
1. Alle obigen Einstellungen außer für Schritt 5, 10 und 12 gelten für die FWD-Betriebsart; diese Einstellungen sind im REV-Betrieb nicht erforderlich, aber die Prüfung jedes Schritts in der REV-Betriebsart sollte ausgeführt werden.
  2. Obiger Abgleich, außer für Schritt 12, nur mit ausgeschalteter Dolby-Rauschunterdrückung ausführen.
  3. Zum Abgleich nur folgende Bänder verwenden:  
Normalband: Maxell UD C-60  
CrO<sub>2</sub> Band: TDK SA C-60  
Reineisenband: TDK MA C-60
  4. Für weitere Einstellungen siehe Abbildung 7-3.

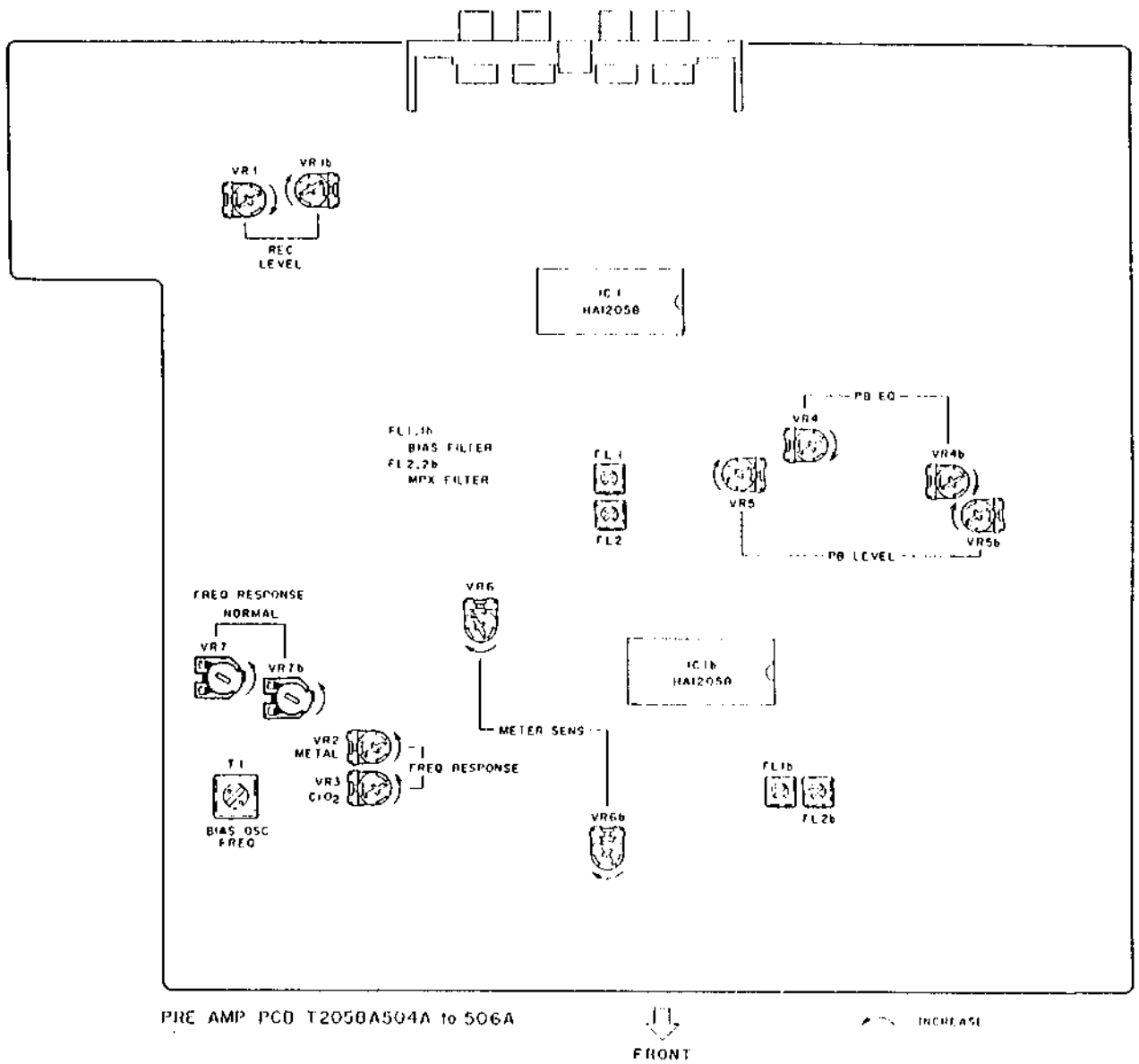
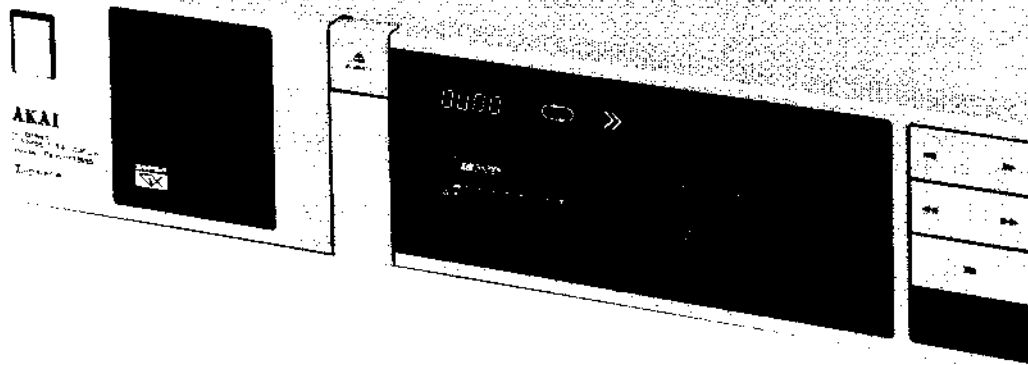

## STEREO CASSETTE DECK

# MODEL GX-R55

SECTION 1	SERVICE MANUAL .....	3
SECTION 2	PARTS LIST .....	15

# SAFETY INSTRUCTIONS

## SAFETY CHECK AFTER SERVICING

Confirm the specified insulation resistance between power cord plug prongs and externally exposed parts of the set is greater than 10 Mohms, but for equipment with external antenna terminals (tuner, receiver, etc.) and is intended for **C** or **A**, specified insulation resistance should be more than 2.2 Mohms (ground terminals, microphone jacks, headphone jacks, line-in-out jacks etc.)

## PRECAUTIONS DURING SERVICING

1. Parts identified by the  $\Delta$  symbol parts are critical for safety.  
Replace only with parts number specified.
2. In addition to safety, other parts and assemblies are specified for conformance with such regulations as those applying to spurious radiation. These must also be replaced only with specified replacements.  
Examples: RF converters, tuner units, antenna selector switches, RF cables, noise blocking capacitors, noise blocking filters, etc.
3. Use specified internal wiring. Note especially:
  - 1) Wires covered with PVC tubing
  - 2) Double insulated wires
  - 3) High voltage leads
4. Use specified insulating materials for hazardous live parts. Note especially:
  - 1) Insulation Tape
  - 2) PVC tubing
  - 3) Spacers (Insulating Barriers)
  - 4) Insulation sheets for transistors
  - 5) Plastic screws for fixing microswitch (especially in turntable)
5. When replacing AC primary side components (transformers, power cords, noise blocking capacitors, etc.), wrap ends of wires securely about the terminals before soldering.

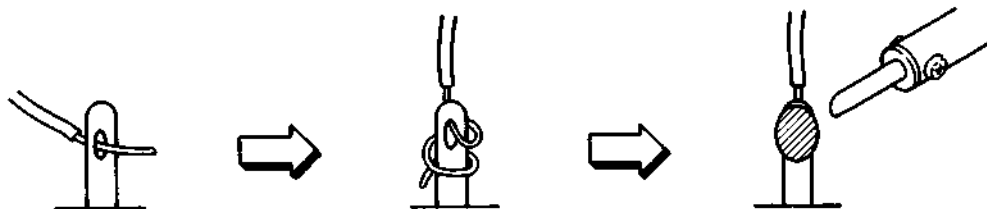

6. Observe that wires do not contact heat producing parts (heatsinks, oxide metal film resistors, fusible resistors, etc.).
7. Check that replaced wires do not contact sharp edged or pointed parts.
8. Also check areas surrounding repaired locations.
9. Use care that foreign objects (screws, solder droplets, etc.) do not remain inside the set.

## VOLTAGE CONVERSION

Models for Japan, Canada, USA, Europe, UK and Australia are not equipped with this facility.

Each machine is preset at the factory according to destination, but some machines can be set to 110V, 120V, 220V or 240V as required.

If **VOLTAGE CHANGE** is necessary, this can be accomplished as follows:

1. Disconnect power cord.
2. Turn the **VOLTAGE SELECTOR** located on the rear panel with a screwdriver until the correct voltage is indicated.

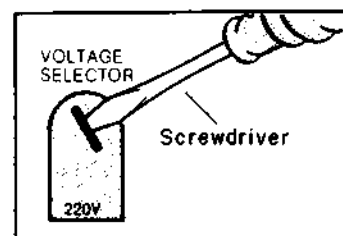

## CYCLE CONVERSION

Cycle conversion is not necessary since GX-R55 use a DC motor.

---

SECTION 1

**SERVICE MANUAL**

TABLE CONTENTS

I. SPECIFICATIONS .....	3
II. DISMANTLING OF UNIT .....	5
III. CONTROLS .....	6
IV. PRINCIPAL PARTS LOCATION .....	7
V. MECHANICAL ADJUSTMENT .....	8
5-1 PINCH ROLLER PRESSURE MEASUREMENT .....	8
5-2 WINDING TORQUE MEASUREMENT IN EACH MODE .....	8
5-3 TAPE SPEED ADJUSTMENT .....	8
VI. HEAD ADJUSTMENT .....	9
6-1 TAPE GUIDE ADJUSTMENT .....	10
6-2 REC/PB HEAD AZIMUTH ADJUSTMENT .....	10
6-3 HEAD HEIGHT ADJUSTMENT .....	10
6-4 HEAD BLOCK PROJECTION ADJUSTMENT .....	10
VII. ELECTRICAL ADJUSTMENT .....	11
7-1 QUICK REVERSE SENSITIVITY ADJUSTMENT .....	11
7-2 PRE-AMP PCB ADJUSTMENT .....	12
VIII. DC RESISTANCE OF HEADS .....	14
IX. P.C BOARD TITLES AND IDENTIFICATION NUMBERS .....	14

For basic adjustments, measuring methods, and operating principles, refer to GENERAL TECHNICAL MANUAL.

# I. SPECIFICATIONS

TRACK SYSTEM	4 track 2 channel stereo system
TAPE	Philips type cassette
HEADS	Erase head x 1 Twin field super GX head for REC/PB x 1
MOTORS	Electronically speed controlled DC motor for capstan drive x 1 DC motor for cam drive x 1
WOW & FLUTTER	±0.07% W. peak (EIAJ) 0.05% (W RMS) 0.12% (DIN)
FREQUENCY RESPONSE	Normal: 20 to 17,000 Hz ±3 dB (EIAJ) CrO <sub>2</sub> : 20 to 18,000 Hz ±3 dB (EIAJ) Metal: 20 to 19,000 Hz ±3 dB (EIAJ)
S/N	60 dB 56 dB (EIAJ) Dolby B ON: Improves up to 5 dB at 1 kHz, 10 dB above 5 kHz. Dolby C ON: Improves up to 15 dB at 500 kHz, 20 dB at 1 kHz to 10 kHz
DISTORTION	0.65% (METAL) 0.55% (METAL) 0.25% (CrO <sub>2</sub> ) 0.15% (NORMAL) } (EIAJ)
INPUT	Line: 410 mV/47 kohms
OUTPUT	Line: 410 mV/1 kohms
POWER REQUIREMENTS	100V, 50/60 Hz for Japan 120V, 60 Hz for USA and Canada 220V, 50 Hz for Europe except UK 240V, 50 Hz for UK and Australia 110V/120V/220V/240, 50/60 Hz switchable for other countries
DIMENSIONS	440 (W) x 105 (H) x 288 (D) mm (17.3 x 4.1x 11.3 inches)
WEIGHT	4.8 kg (10.6 lbs)

\* For improvement purposes, specifications and design are subject to change without notice.

\* Noise reduction manufactured under license from Dolby Laboratories Licensing Corporation. "Dolby" and the Double-D symbol are trade marks of Dolby Laboratories Licensing Corporation.

## II. DISMANTLING OF UNIT

In case of trouble, etc. necessitating dismantling, please dismantle in the order shown in the photographs. Reassemble in reverse order.

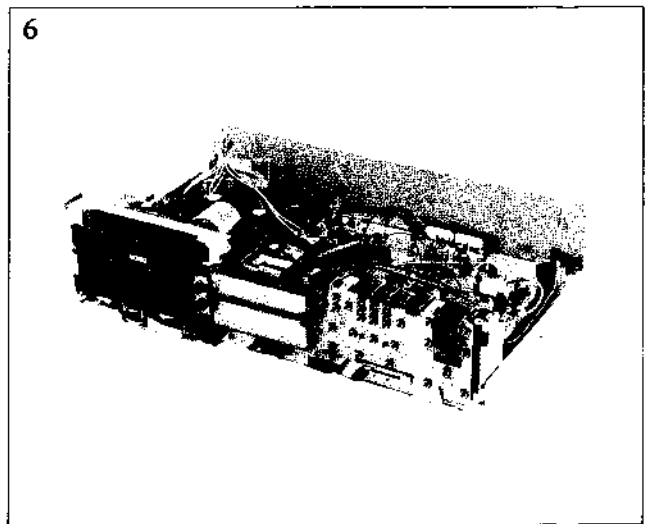
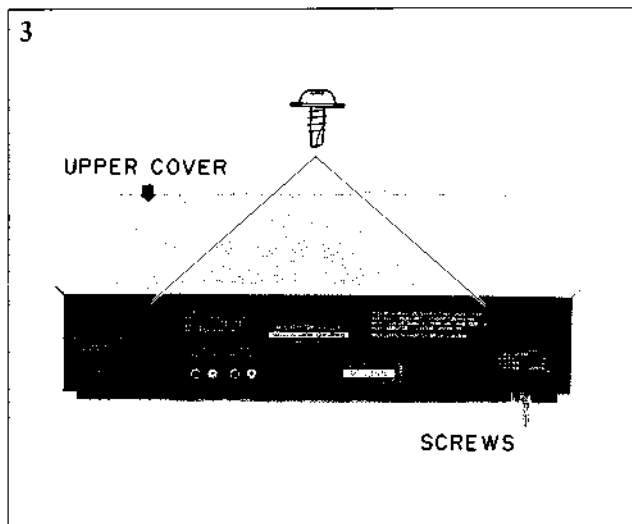
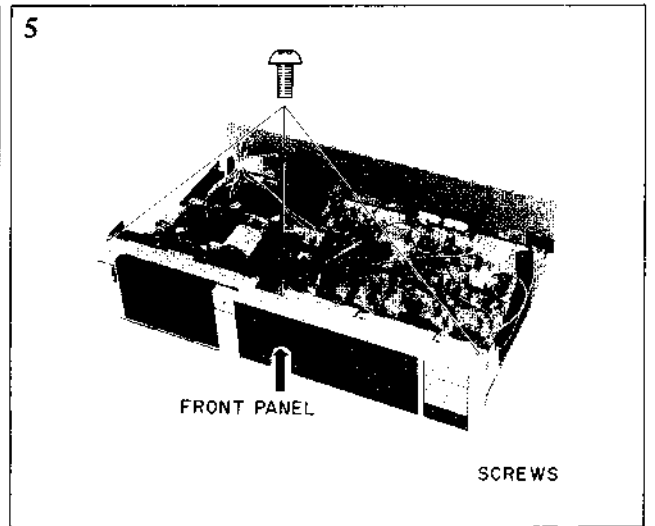
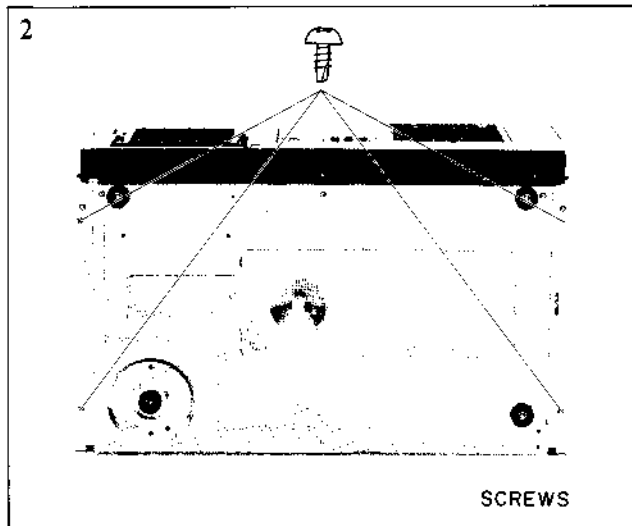
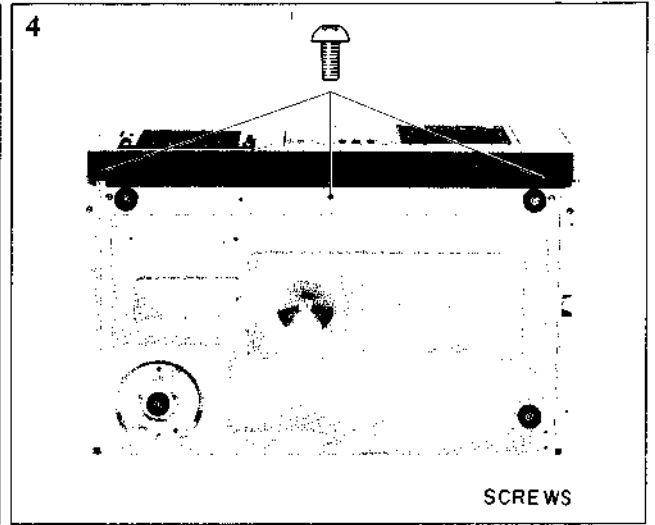
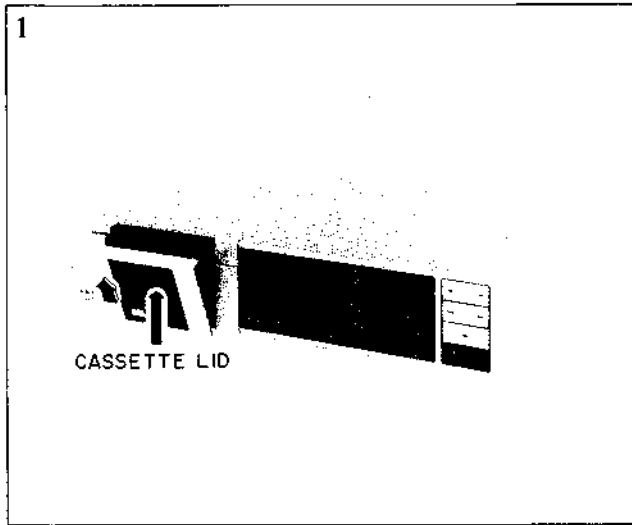

### III. CONTROLS

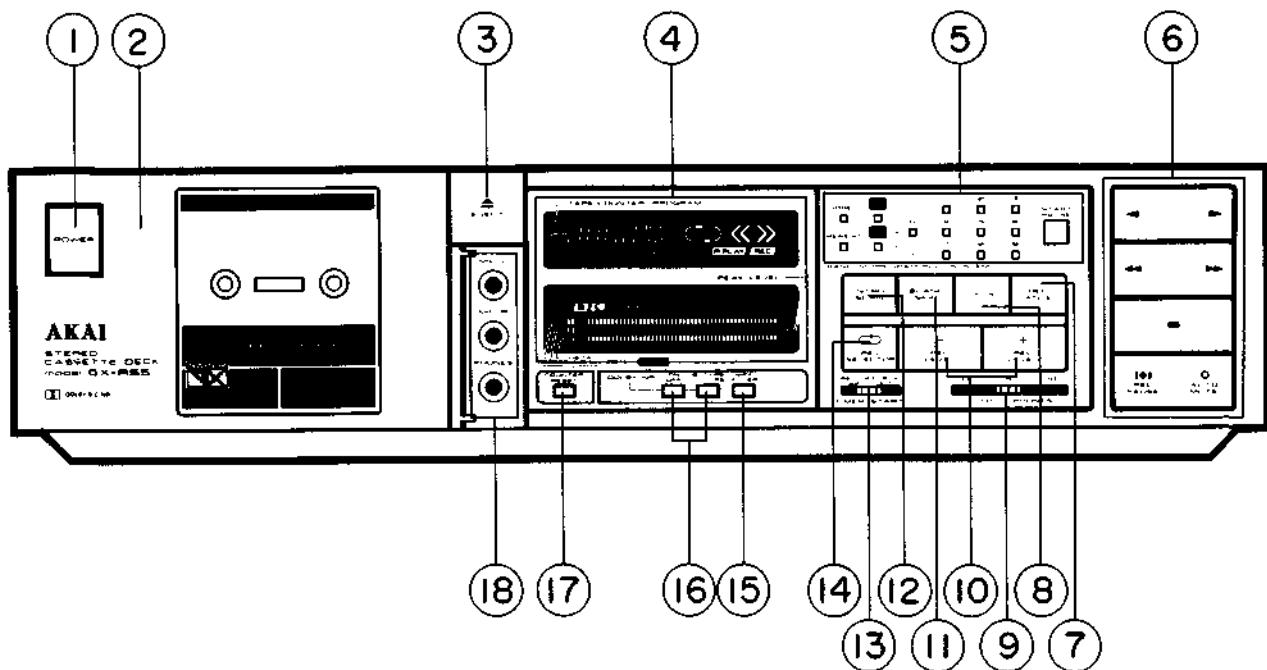

Fig. 3-1

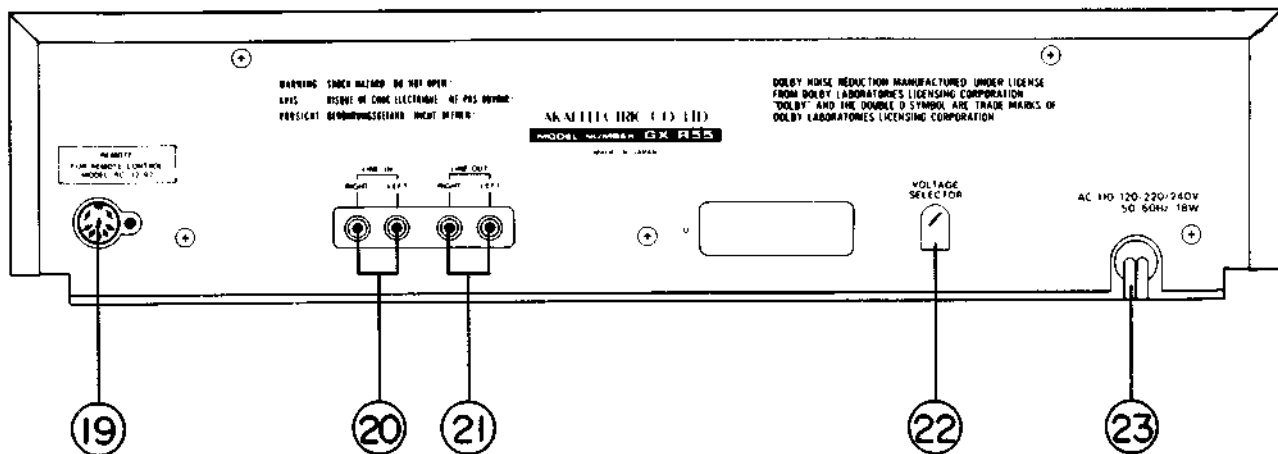

Fig. 3-2

- |  |   |
|--|---|
| <ol style="list-style-type: none"> <li>1. POWER SWITCH</li> <li>2. CASSETTE LID</li> <li>3. EJECT BUTTON</li> <li>4. FL DISPLAY</li> <li>5. RPPS BUTTONS</li> <li>6. OPERATION BUTTONS</li> <li>7. REC CANCEL BUTTON</li> <li>8. IPLS BUTTON</li> <li>9. OUTPUT/PHONES CONTROL</li> <li>10. REC LEVEL CONTROL</li> <li>11. BLANK SKIP BUTTON</li> <li>12. INTRO SCAN BUTTON</li> </ol> | <ol style="list-style-type: none"> <li>13. TIMER START SELECTOR</li> <li>14. REV SELECTOR BUTTON</li> <li>15. MPX FILTER BUTTON</li> <li>16. DOLBY NR SWITCH AND SELECTOR</li> <li>17. COUNTER RESET BUTTON</li> <li>18. CONTAINS JACK FOR MIC L/R AND HEADPHONE</li> <li>19. REMOTE CONTROL JACK</li> <li>20. LINE IN JACKS</li> <li>21. LINE OUT JACKS</li> <li>22. VOLTAGE SELECTOR ( <input type="checkbox"/> MODEL ONLY)</li> <li>23. AC POWER CORD</li> </ol> |
|--|---|



# IV. PRINCIPAL PARTS LOCATION

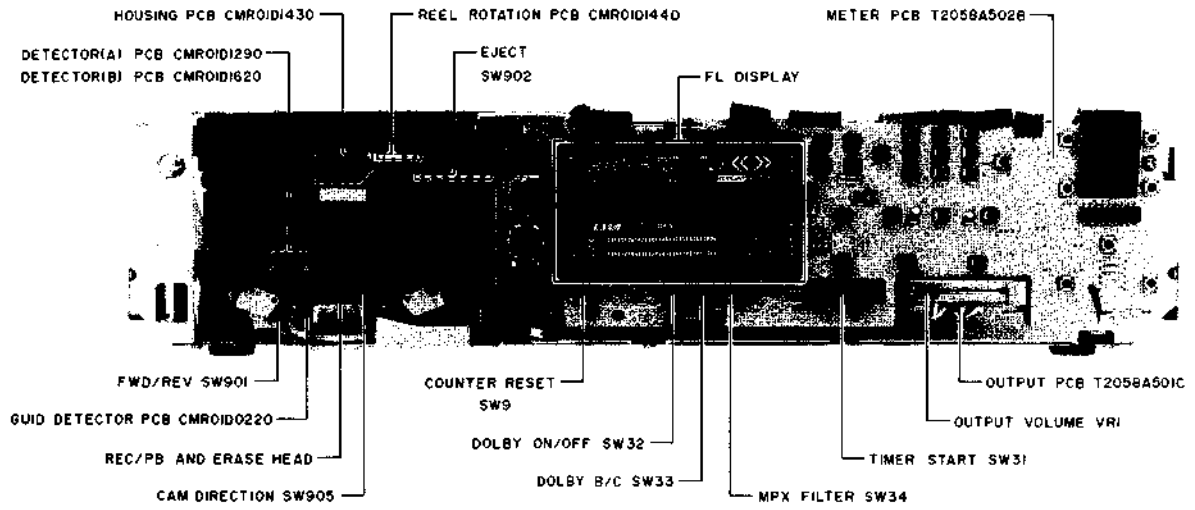

Fig. 4-1 Front View

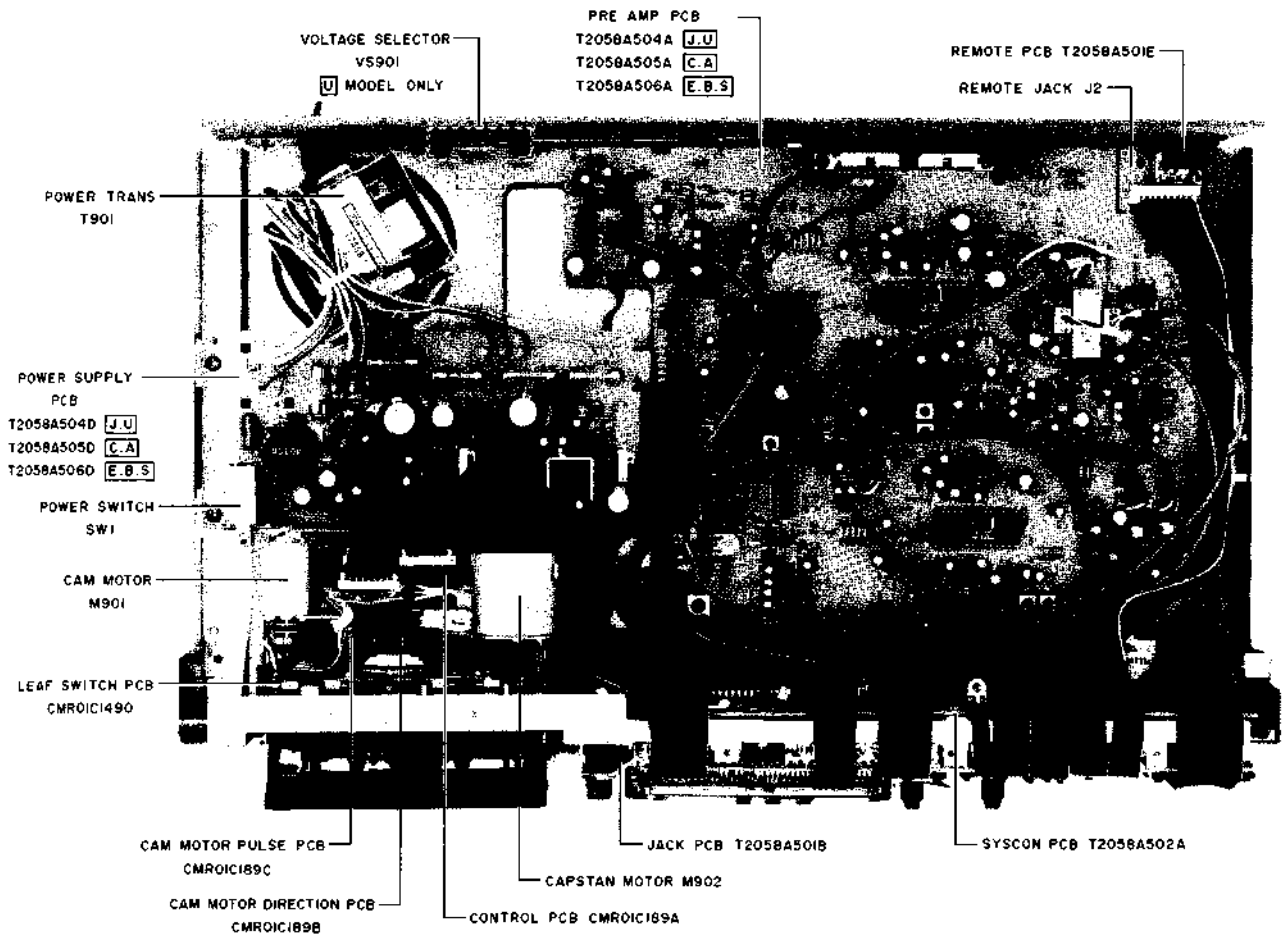

Fig. 4-2 Top View

## V. MECHANICAL ADJUSTMENT

### 5-1 PINCH ROLLER PRESSURE MEASUREMENT (Refer to Fig. 5-1)

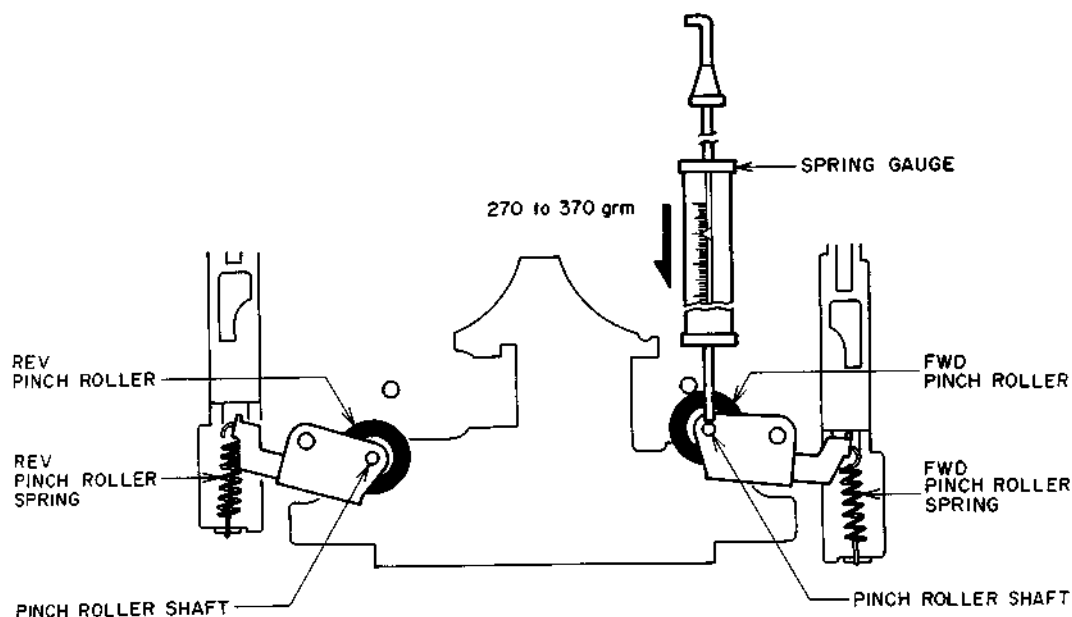

Fig. 5-1

Put in FWD PLAY Mode. Push pinch roller shaft down with the spring gauge, and push the pinch roller 1 to 2 mm away from the capstan and release slowly. Read the spring gauge at the moment the pinch roller

touches the capstan and begins to rotate. Specified contact pressure measurement is 270 to 370 grams. If the correct measurement is not obtained, replace the pinch roller spring. Do the same for the reverse side.

### 5-2 WINDING TORQUE MEASUREMENT IN EACH MODE (Refer to Fig. 5-2)

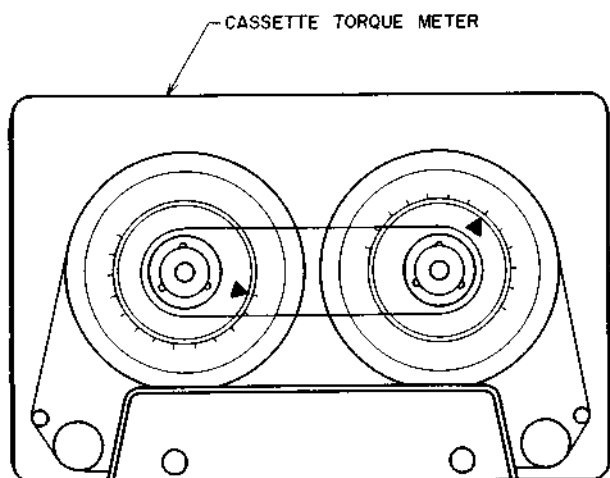

Fig. 5-2

Insert a cassette torque meter (AJ-751179) and measure in each mode.

For Fast Forward and Rewind, measure at the end of the tape when the tape has stopped running.

Forward or Reverse mode

Take up Torque: 25 to 45 g-cm

Back Tension Torque: 2 to 5 g-cm

Fast Forward or Rewind mode

Take up Torque: 70 to 150 g-cm

### 5-3 TAPE SPEED ADJUSTMENT (Refer to Fig. 5-3)

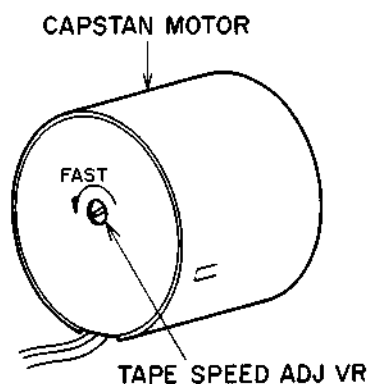

Fig. 5-3 Location of Tape Speed Adjustment Variable Resistor

Fig. 5-3 Location of Tape Speed Adjustment Variable Resistor Connect a frequency counter to Line Output terminal. Playback a 1,000 Hz pre-recorded Test Tape (AT-750744), or 3,150 Hz pre-recorded Test Tape (AT-751263), and adjust the Tape Speed Adjustment Variable Resistor (See Fig. 5-3) to obtain a tape speed of  $1000 \pm 3$  Hz, or  $3150 \pm 10$  Hz.

# VI. HEAD ADJUSTMENT

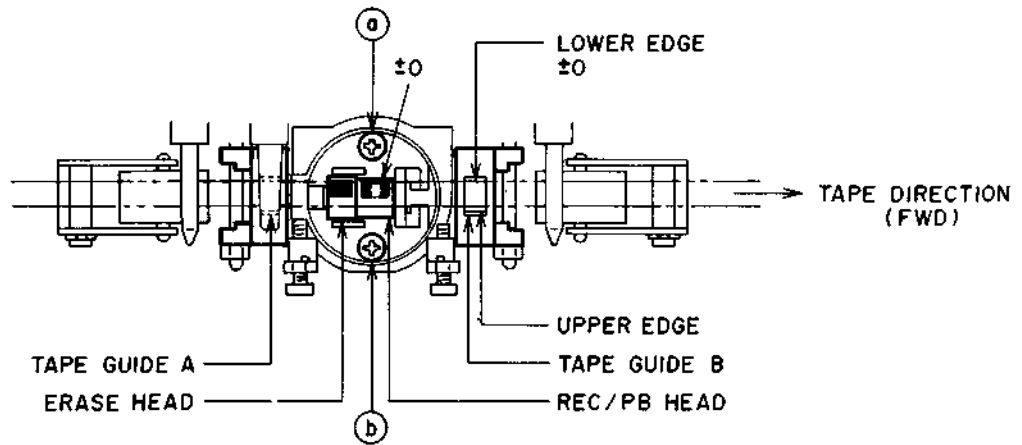

Fig. 6-1

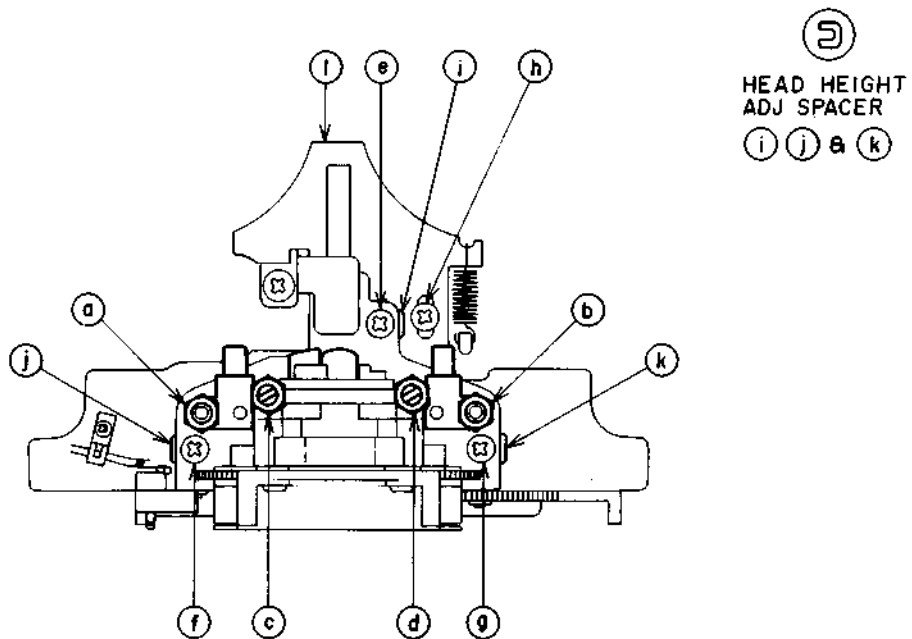

Fig. 6-2

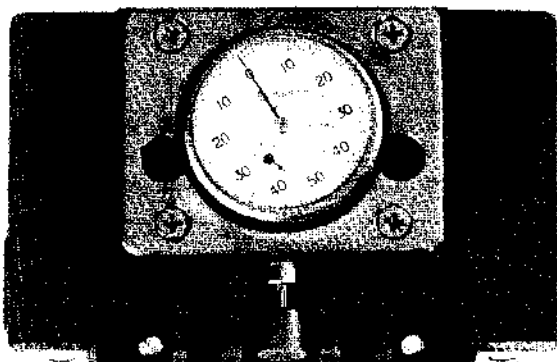

Fig. 6-3 Cassette Head Projection Gauge (TF-111CJ)



Fig. 6-4 Mirror Cassette Tape (MC-12C)

## 6-1 TAPE GUIDE ADJUSTMENT

(Refer to Figs. 6-1, 6-2, & 6-4)

- 1) Use a mirror Cassette Tape (AT-751178) shown in Fig. 6-3 for better visibility of the head area, and select PLAY mode.
- 2) Adjust the tape guides A and B by turning the tape guide height adjustment nuts (a) and (b) in Fig. 6-2, so that the tape runs smoothly by the lower edge of both tape guides, and the tape is not hitched by those tape guides.

## 6-2 REC/PB HEAD AZIMUTH ADJUSTMENT

Playback a 10 kHz Head Azimuth Adjustment Tape (AT-750778) and adjust the screws (c) (FWD direction) and (d) (REV direction), so that the levels of both channels are maxima. (NOTE: Avoid turning the screws too far as other false maxima exist further away on both sides of the correct position.)

## 6-3 HEAD HEIGHT ADJUSTMENT

This adjustment is not necessary since GX-R55 is equipped with Rotary Head System (with Erase & REC/PB combination head). However, the confirmation of head height is necessary and it can be done as follows.

- 1) Confirm the azimuth in item 6-2.
- 2) Playback a 315 Hz (or 333 Hz) PB Level Adjustment Tape (AT-750773) in FWD Play mode, and adjust the PB level Adjuster (VR5 on Pre-Amp P.C Board) so that the LINE OUT level of left channel is  $-5.5$  dBm. Then, check the level of the same channel in REV mode. The difference in level between FWD and REV modes should be within  $\pm 1$  dBm. ( $-4.5$  dBm to  $-6.5$  dBm)
- 3) If the difference is more than  $\pm 1$  dBm in item 2), adjust the tape guides A & B by turning both Tape Guide Height Adjustment screws (a) & (b) in the same direction by  $1/4$  turn ( $\pm 0.1$  mm), so that difference is within  $\pm 1$  dBm.
- 4) The Head Height Adjustment is necessary if still the difference could not be corrected by above adjustment. It can be done by changing the Head Height Adjustment Spacers (i) & (k). (The thicknesses of these spacers are (i) =  $0.45$  mm, (k) & (l) =  $0.3$  mm).

Loosen the screws (e) (f) & (g) for the spacer replacement.

If the level is lower in REW mode, it means that the head is too high, therefore replace the spacers by thinner ones. When the level is higher in REV mode, replace them by thicker ones.

After the replacement of those spacers, do the same adjustment in item 1) and check the level of LINE OUT is  $-5.5$  dBm  $\pm 1$  dBm.

For the further confirmation, playback a 4 Track Head Height Adjustment Tape (1 kHz/4 Track, AT-750775). Line output level of both channels should be more than  $-8$  dBm and the difference in level between FWD and REV modes should be within  $\pm 1$  dBm. Otherwise do the fine adjustment in the same manners as item 3) & 4).

- 5) When the head replacement is necessary, loosen only the screws (a) & (b) in Fig. 6-1 for easy replacement.

## 6-4 HEAD BLOCK PROJECTION ADJUSTMENT (Refer to Figs. 6-2 & 6-3)

Use a cassette Head Projection Gauge (AT-751180) and select FWD or REV play mode.

Loosen the screw (h) and adjust Chassis Head Part (i) so that the gauge indication at the time is  $3.4 \pm 0.15$  mm. After the adjustment, apply paint-lock on the screw (h).

## VII. ELECTRICAL ADJUSTMENT

### 7-1 QUICK REVERSE SENSITIVITY ADJUSTMENT

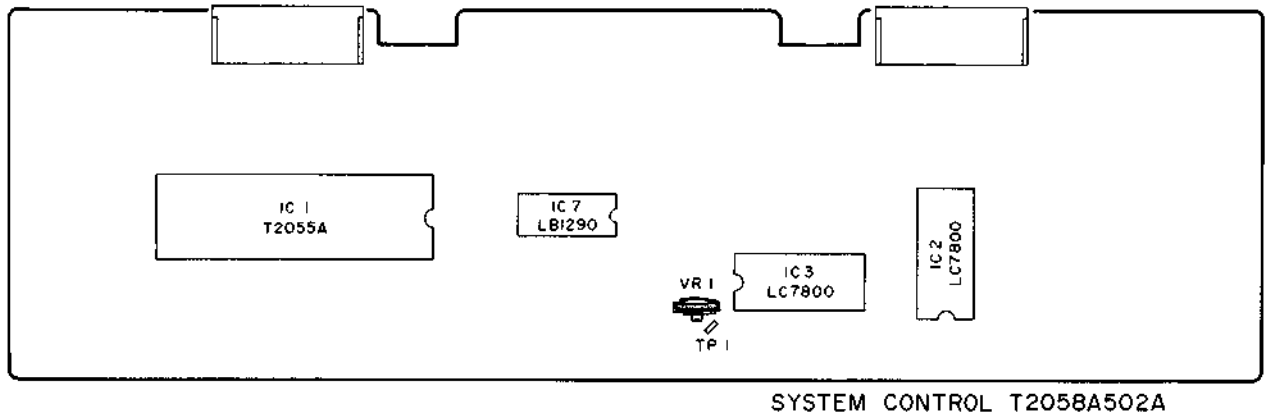

Fig. 7-1 GX-R55 Quick Rev. Sens. Adjustment point

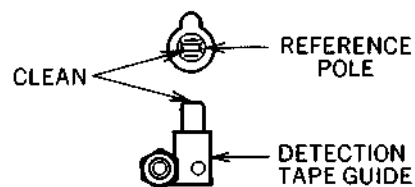

Fig. 7-2

- 1) Make a tapeless cassette pack by removing the tape from the white colored test tape.
- 2) Connect a Digital Voltmeter between TP-1 and Ground.
- 3) Using the tapeless cassette pack, adjust VR1 so that the Digital voltmeter reads  $14V \pm 0.5V$  DC at FWD play mode.

- 4) If the Digital voltmeter reading is not increase to 14V DC at VR1 maximum. Remove the Resister R18 (150 kohms) from the system control P.C Board, and again adjust VR1 as the same manner in item 3).

**NOTE:** Clean the reference pole and the Detection tape guide before adjustment. (Refer to Fig. 7-2)

## 7.2 PRE-AMP P.C BOARD ADJUSTMENT

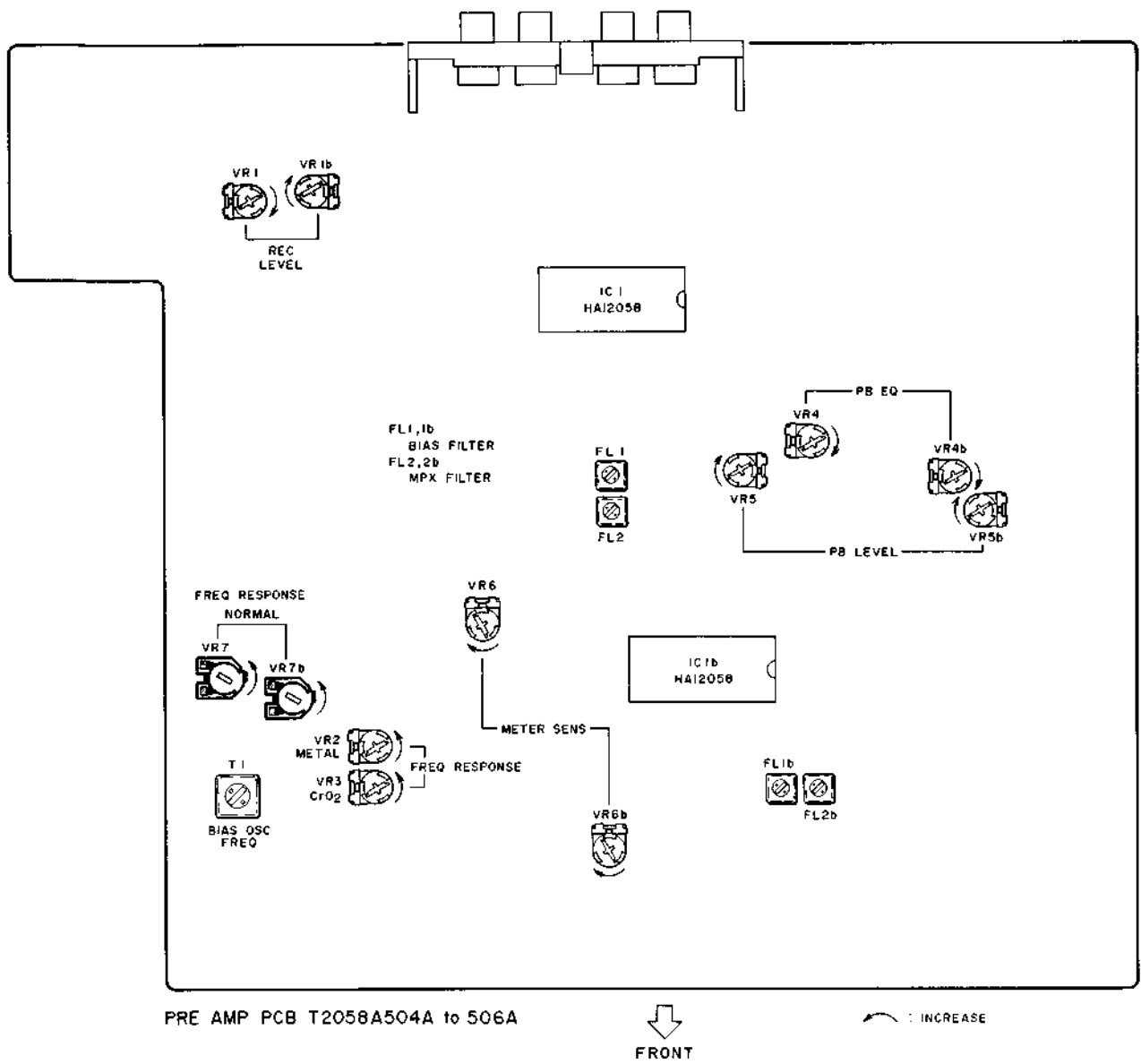

Fig. 7-3 GX-R55 Pre-Amp PCB ADJ Points

Step	Adjustment Item	Test Tape & Supply Signal	Mode	Adjustment Parts	Results	Remarks
1	FWD PB Level	333 Hz (AT-750773) or 315 Hz (AT-750773)	FWD PB	VR5	-6.1 ± 0.2 dBm or -5.5 ± 0.2 dBm	
2	REV PB Level	333 Hz (AT-750773) or 315 Hz (AT-750773)	REV PB		-6.1 ± 0.2 dBm or -5.5 ± 0.2 dBm	Confirmation
3	FWD PB EQ	10 kHz-15 dB (AT-750778)	FWD PB	VR4	-20.5 ± 0.5 dBm	
4	REV PB EQ	10 kHz-15dB (AT-750778)	REV PB		-20.5 ± 0.5 dBm	Confirmation
5	BIAS OSC FREQ.	No Signal Input	REC	T1	100 kHz ± 0.5 kHz	
6	Normal Position Frequency Response	Normal Blank Tape 1 kHz, 10 kHz -25.5 dBm	REC/PB	VR7	1 kHz, 10 kHz Flat ± 0.3 dB	
7	CrO <sub>2</sub> Position Frequency Response	CrO <sub>2</sub> Blank Tape 1 kHz, 10 kHz -25.5 dBm	REC/PB	VR3	1 kHz, 10 kHz Flat ± 0.8 dB	
8	Metal Position Frequency Response	Metal Blank Tape 1 kHz, 10 kHz -25.5 dBm	REC&PB	VR2	1 kHz, 10 kHz Flat ± 0.8 dBm	
9	REC Level	Normal Blank Tape 1 kHz, -5.5 dBm	REC/PB	VR1	-5.5 ± 0.5 dBm	
10	Bias Filter	No Signal input	REC	FL1	Minimum output	Set REC Volume to Maximum
11	Meter Sensitivity	1 kHz input	REC PAUSE	VR6	Ovu indicated at Line output -5.9 ± 0.2 dBm	At this time, 0.1 dB decrease the Line Output level and confirm the Ovu indicator is light off.
12	MPX Filter	19 kHz from oscillator	REC	FL2	Minimum output	MPX Filter SW "ON"

- NOTES:**
1. Above adjustments except for Step 5, 10 to 12 are all at FWD mode, and these adjustments at REV mode are not necessary, but the confirmation of each step at REV mode should be made.
  2. Above adjustment except for step 12, adjustment should be made with Dolby N.R at OFF position.
  3. Use only the tapes recommended for each adjustment:  
 NORMAL tape : MAXELL UD C-60  
 CrO<sub>2</sub> tape : TDK SA C-60  
 METAL tape : TDK MA C-60
  4. Refer to Fig. 7-3 for above adjustments.

## VIII. DC RESISTANCE OF HEADS

Description	DC Resistance
REC HEAD	50 ohms $\pm$ 10%
P.B HEAD	340 ohms $\pm$ 10%
ERASE HEAD	3.5 ohms $\pm$ 10%

## IX. P.C BOARD TITLES AND IDENTIFICATION NUMBERS

P.C Board Title		P.C Board Number	Remark
PRE - AMP	P.C Board	T2058A504A	J U
PRE - AMP	P.C Board	T2058A 505A	C A
PRE - AMP	P.C Board	T2058A506A	E B S
JACK	P.C Board	T2058A501B	
OUTPUT	P.C Board	T2058A501C	
REMOTE	P.C Board	T2058A501E	
SYSCON	P.C Board	T2058A502A	
METER	P.C Board	T2058A502B	
POWER SUPPLY	P.C Board	T2058A504D	J U
POWER SUPPLY	P.C Board	T2058A505D	C A
POWER SUPPLY	P.C Board	T2058A506D	E B S
FLEXIBLE	P.C Board	CMR01A0240	
CONTROL	P.C Board	CMR01C189A	
CAM MOTOR PULSE	P.C Board	CMR01C189C	
CAM MOTOR DIRECTION	P.C Board	CMR01C189B	
LEAF SWITCH	P.C Board	CMR01C1490	
REEL ROTATION	P.C Board	CMR01D144D	
GUID DETECTOR	P.C Board	CMR01D0220	
DETECTOR (A)	P.C Board	CMR01D1290	
DETECTOR (B)	P.C Board	CMR01D1620	
HOUSING	P.C Board	CMR01D1430	



---

SECTION 2

**PARTS LIST**

TABLE OF CONTENTS

RECOMMENDED SPARE PARTS .....	17
1. MECHA CMROI BLOCK .....	18
2. PRE AMP AND POWER SUPPLY P.C BOARD BLOCK .....	20
3. SYSTEM CONTROL AND METER P.C BOARD BLOCK .....	20
4. ASSEMBLY BLOCK .....	21
5. FINAL ASSEMBLY BLOCK .....	22
INDEX .....	23

Resistors and Capacitors which are not listed in this parts list, please refer to COMMON LIST FOR SERVICE PARTS.

## ATTENTION

1. When placing an order for parts, be sure to list the parts no., model no., and description. There are instances in which if any of this information is omitted, parts cannot be shipped or the wrong parts will be delivered.
2. Please be careful not to make a mistake in the parts no. If the parts no. is in error, a part different from the one ordered may be delivered.
3. Because parts number and parts unit supply in the Preliminary Parts List may be partially changed, please use this parts list for all future reference.

## HOW TO USE THIS PARTS LIST

1. This Parts List shows the parts that are considered necessary for repairs. Other parts, such as resistors and capacitors, are shown in the "Common List for Service Parts". Select and order such parts from the "Common List for Service Parts".
2. The Recommended Spare Parts shows those parts in the Parts List which are considered particularly important for service.
3. Parts not shown in the Parts List and "Common List for Service Parts" will not be supplied in principle.
4. How to read list

a) Mechanism Block

b) P.C Board Block

### 2. HEAD BASE BLOCK

REF. NO.	PARTS NO.	DESCRIPTION
2-1x	BH-T2023A320A	HEAD BASE BLOCK GX-F66R
2-2	HP-H2206A010A	HEAD R/P PR4-8FU C
2-3	ZS-477876	PAN20x03STL CMT
2-4	ZS-536488	BID20x08STL CMT
2-5	ZG-402895	CS ANGLE ADJUST SPRING

SP (Service Parts) Classification

A small "x" indicates the inability to show that particular part in the Photo or Illustration.

This number corresponds with the individual parts index number in that figure

This number corresponds with the Figure Number

### 6. SYS. CON. P.C BOARD BLOCK

REF. NO.	PARTS NO.	DESCRIPTION
6-1	BA-T2034A070A	PC SYS CON BLK GX-F44R
6-1C1	EI-324536	IC HD14049BP
6-1C2	EI-336801	IC MB8841-564M
6-1C3	EI-331661	IC SN7405N
6-1C4	EI-336725	IC M54527P
6-TR1to4	ET-200985	TR 2SC2603 F,G
6-TR5to28	ET-554657	TR 2SA733A P,Q
6-D1	ED-318292	D SILICON H 1S2473T-77 T26
6-D2to4	ED-308952	D GERMA V 1K34A-LR F07
6-D5to10	ED-318292	D SILICON H 1S2473T-77 T26
6-X1	EI-318384	OSC X'TAL NC-18C 3.579545MHZ

SP (Service Parts) Classification

This reference numbers corresponds with symbol numbers of Schematic Diagrams.

5. Both the kind of part and installation position can be determined by the Parts Number. To determine where a parts number is listed, utilize Parts Index at end of Parts List. It is necessary first of all to find the Parts Number. This can be accomplished by using the Reference Number listed at right of parts number in the Parts Index.

## WARNING

⚠ INDICATES SAFETY CRITICAL COMPONENTS. FOR CONTINUED SAFETY, REPLACE SAFETY CRITICAL COMPONENTS ONLY WITH MANUFACTURER'S RECOMMENDED PARTS.

## AVERTISSEMENT

⚠ IL INDIQUE LES COMPOSANTS CRITIQUES DE SURETE. POUR MAINTENIR LE DEGRE DE SECURITE DE L'APPAREIL NE REMPLACER LES COMPOSANTS DONT LE FONCTIONNEMENT EST CRITIQUE POUR LA SECURITE QUE PAR DES PIECES RECOMMANDEES PAR LE FABRICANT.

## RECOMMENDED SPARE PARTS

Because, if the parts listed below are on hand, almost any repair can be accomplished, we suggest that you stock these Recommended Spare Parts Items.

NO.	PARTS NO.	DESCRIPTION
1	BL-T2045A050A	ARM PINCH ROLLER (L) BLK HX-R5
2	BL-T2045A060A	ARM PINCH ROLLER (R) BLK HX-R5
3	BM-B604491	Δ MOTOR (PULLEY) PART EG-510ED 2B2 (M902)
4	BM-B604490	Δ MOTOR OPERATION (PULLY) PART (M901)
5	BR-344098	REEL TABLE (A) ASSY
6	BT-349620	Δ TRANS POWER T2059 (A,C)
7	BT-349622	Δ TRANS POWER T2059 (B, S)
8	BT-349621	Δ TRANS POWER T2059 (E, V)
9	BT-349619	Δ TRANS POWER T2059 (J)
10	BT-349618	Δ TRANS POWER T2059 (U)
11	ED-330319	Δ D SILICON DBA10B 100/1.0A
12	ED-349662	Δ D SILICON DS135E-FA6 100/1.0A
13	N ED-308953	D GERMA H 1K34A-LH S12
14	ED-310340	D LED GL350 INFRARED RAY (D902)
15	ED-349662	D SILICON DS135E-FA6 100/1.0A
16	ED-301911	D SILICON H DS448
17	ED-344280	D SILICON H GMA-01-FY2 F05
18	ED-624903	D SILICON H 1S2473
19	ED-338092	D ZENER H HZ2FA F10 B1
20	N ED-346504	D ZENER H HZ20FA F10 3
21	ED-346455	D ZENER H HZ27FA F10 A1
22	N ED-346440	D ZENER H HZ5FA F10 B1
23	N ED-346446	D ZENER H HZ5FA F10 C3
24	N ED-346450	D ZENER H HZ6FA F10 B2
25	N ED-346454	D ZENER H HZ6FA F10 C3
26	N ED-346469	D ZENER H HZ9FA F10 B2
27	N ED-346264	D ZENER V HZ11LS7 F05 B2
28	ED-348062	D ZENER V HZ15-2S7
29	N ED-338454	D ZENER V HZ9C-2S7
30	EF-339906	Δ FUSE SEMKO T 250V 0.25A (E,B,S)
31	EF-668474	Δ FUSE SEMKO T 250V 0.40A (E,B,S)
32	EF-593706	Δ FUSE SEMKO T 250V 0.50A (E,B,S)
33	EF-306125	Δ FUSE TSC A 250V 0.31A (U,J)
34	EF-327103	Δ FUSE TSC A 250V 0.50A (U,J)
35	EF-309388	Δ FUSE TSC A 250V 0.80A (U,J)
36	EF-308848	Δ FUSE TSC 125V 0.40A (C,A)
37	EF-309390	Δ FUSE TSC 125V 0.50A (C,A)
38	EF-309391	Δ FUSE TSC 125V 0.80A (C,A)
39	EH-351182	FILTER DB 201AK-005 100KHZ
40	EH-351183	FILTER DB 201AK-006 19KHZ
41	EI-330352	IC BA6109
42	EI-337845	IC BA6146 M
43	EI-349196	IC HA12058
44	EI-337013	IC LB1290
45	EI-345765	IC LB1292
46	EI-343417	IC LB1294
47	N EI-337009	IC LC4049B
48	EI-345759	IC LC7530
49	EI-337008	IC LC7800
50	EI-348701	IC M51143L
51	EI-337228	IC M5218L0
52	EI-348785	IC M5220L
53	EI-349388	IC M54418P
54	EI-349877	IC T2055A
55	EI-349372	OSC CE CSA4.00MG 4MHZ
56	EL-348214	PL LEAD 28.0V 24MA
57	EM-349595	IND FL FIP48AW11YS
58	EM-349594	IND FL FIP6GM7
59	EO-352104	COIL OSC 1 94-5009-01 100KHZ
60	EO-315758	COIL TUN 1 100Z-431 100.00KHZ
61	EO-337044	COIL TUN 1 102AK-005

NO.	PARTS NO.	DESCRIPTION
62	EO-337055	COIL VARI 1 FE002S 10MH
63	EQ-337067	RELAY LEAD LAB2NS 2NO 18V
64	ES-305733	Δ SW SELECTOR HXW0131-260 01-4 (U)
65	ES-344104	SW LEAF BSW-191 01-1 NO (SW901)
66	ES-344101	SW LEAF MD-1003 01-1 NO (SW905)
67	ES-336814	SW LEAF MSW-1150NBK 01-1 NO (SW902)
68	ES-344253	SW LEAF MSW-1418J 01-1 NO
69	ES-344257	SW LEAF MSW-1418L 01-1 NO
70	ES-347966	SW PUSH ESB-649 01-2-2 N
71	ES-344270	SW PUSH SDLD1P 01-1
72	ES-349597	SW SLIDE 00130329 BLACK 01-3 S
73	ES-349698	SW SLIDE 00130333 GRAY 01-3 S
74	ES-349640	SW TACT B3F-1050
75	ES-349367	SW TACT KHH10906
76	ET-344102	PHOTO SENSOR GP-1S04
77	ET-310341	PHOTO SENSOR PT350 T (TR902)
78	ET-311977	PHOTO SENSOR SPI-201
79	N ET-200558	TR 2SA1115 E,F
80	ET-346298	TR 2SA1246 S,T
81	ET-348950	TR 2SA1345
82	ET-349605	TR 2SA1346
83	ET-349593	TR 2SA1348
84	ET-349718	TR 2SA1392 S,T
85	ET-352726	TR 2SA1392 T,U
86	ET-337968	TR 2SA999 E,F
87	ET-353067	TR 2SB744 P,Q,R
88	N ET-309353	TR 2SC2274K E,F
89	ET-328578	TR 2SC2320 E,F
90	N ET-200505	TR 2SC2603 E,F
91	ET-349272	TR 2SC3242A E,F
92	ET-349606	TR 2SC3382 T,U
93	ET-349081	TR 2SC3383 S,T
94	ET-349608	TR 2SC3383 T,U
95	ET-350795	TR 2SC3399
96	ET-349592	TR 2SC3400
97	N ET-328868	TR 2SD1012-V G,H
98	ET-310148	TR 2SD612K E,F
99	N ET-307349	TR 2SD794 P,Q
100	ET-349979	TR 2SD794 P,Q,R
101	N EV-345610	R S-FIX H H0811C307A 3P 102
102	N EV-342939	R S-FIX H H0811C313A 3P 103
103	N EV-345611	R S-FIX H H0811C358A 3P 502
104	N EV-342942	R S-FIX H H0811C362A 3P 503
105	EV-336785	R S-FIX H TM8KV2-1S 3P 0.50W 104
106	EV-522652	R S-FIX V V8K1-1 3P 105
107	EV-337841	VR SLIDE 30P2SV0A B103
108	HR-H2501A010A	HEAD COMBO EPR4-9
109	MB-344088	BELT CAM
110	MB-344041	BELT CAPSTAN
111	MB-344042	BELT WIND (A)
112	MB-344043	BELT WIND (B)
113	MB-344028	PULLEY RUBBER
114	MB-345139	WHEEL RUBBER
115	MI-344095	IDLER PLAY(L) ASSY
116	MI-344094	IDLER PLAY(R) ASSY

"NOTE" N : New Parts

### SYMBOL FOR DESTINATION

- A: AAL (U.S.A)
- B: UK (England)
- C: CSA (Canada)
- J: JPN (Japan)
- S: SAA (Australia)
- U: U/T (Universal Area)
- E: CEE (Europe)

**MECHA CMR01 BLOCK**

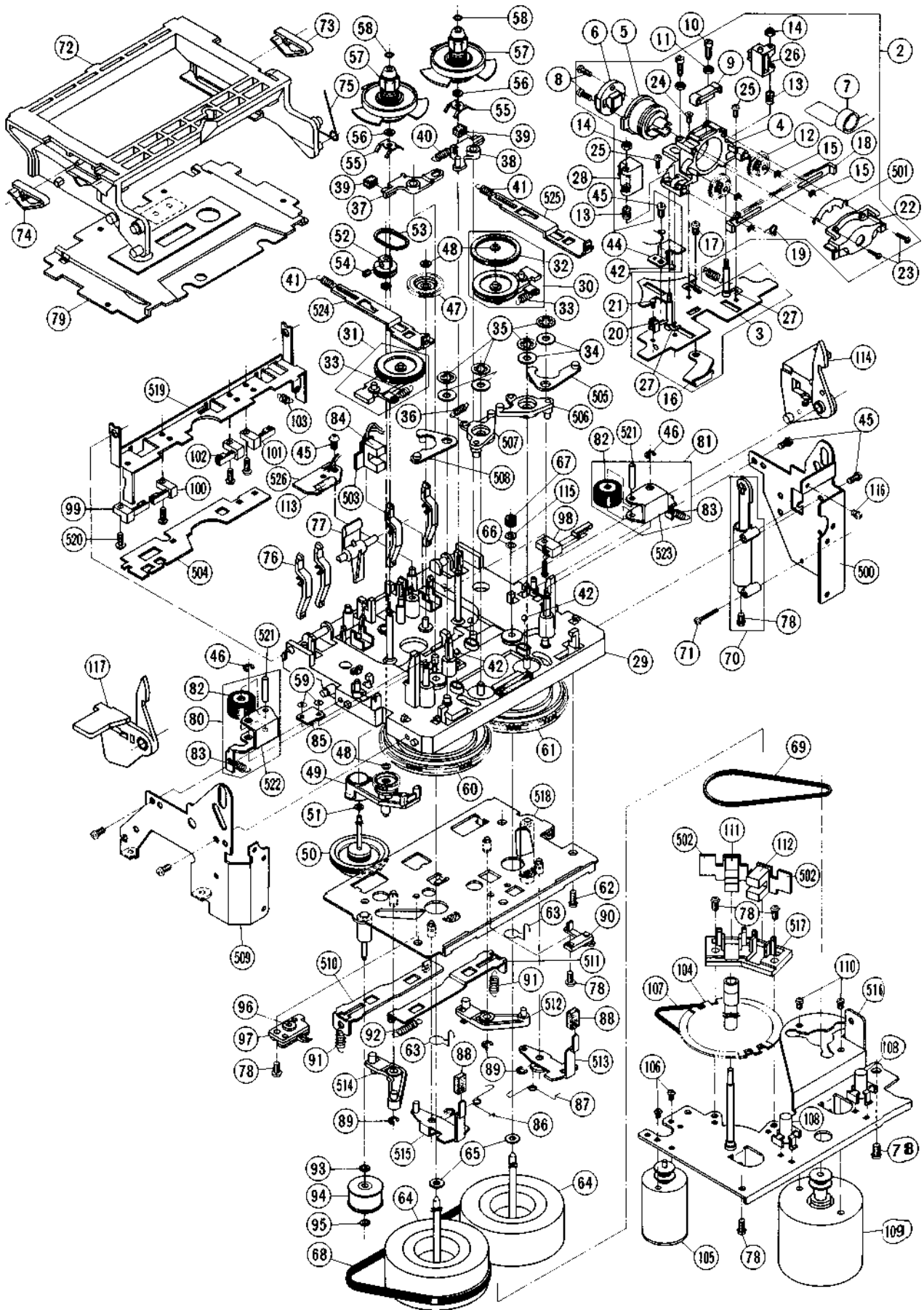

# 1. MECHA CMR01 BLOCK

REF. NO.	PARTS NO.	DESCRIPTION	REF. NO.	PARTS NO.	DESCRIPTION
1-1	BB-T2045A020B	MECHA CMR01 BLK GX-R6	1-62	ZS-336613	PT PAN26x06STL CMT
1-2	BH-T2045A030B	HEAD BLK GX-R6	1-63	ZG-344064	SP PULL EARTH
	<b>HEAD BLOCK</b>		1-64	BF-344029	FLYWHEEL
1-3	MZ-B344008	CHASSIS HEAD PART	1-65	ZW-344047	SPACER FLYWHEEL
1-4	HZ-B344009	HOUSING ROTARY PART	1-66	ZW-349047	WASHER OIL STOPPER
1-5	HZ-B344006	HOLDER ROTARY PART	1-67	MB-344028	PULLEY RUBBER
1-6	HR-H2501A010A	HEAD COMBO EPR4-9	1-68	MB-344041	BELT CAPSTAN
1-7	EA-343944	PC HEAD (B) CMR01A0240	1-69	MB-344042	BELT WIND (A)
1-8	ZS-245147	CTS20x06STL BNI	1-70	MZ-344099	DUMPER ASSY
1-9	HZ-344011	GUIDE ROTARY HEAD	1-71	ZS-343113	ST PAN20x12STL CMT
1-10	ZS-344001	SCREW AZIMUTH	1-72	SP-344057	LID CASE
1-11	ZW-273734	N20BRS NI3 1	1-73	ZG-336615	SP PLATE CASSETTE HOLDER (B)
1-12	MZ-344004	GEAR HEAD	1-74	ZG-344939	SP PLATE CASSETTE HOLDER
1-13	ZG-344012	SP PUSH GUIDE TAPE	1-75	ZG-344058A	SP TORSION LID (R)
1-14	ZW-618884	N20STL CMT 1	1-76	ML-344286	LEVER DETECTION (A)
1-15	ZW-391397	RING E120SUP CMT	1-77	ML-344053	LEVER DETECTION (B)
1-16	MZ-344002	PLATE ADJUST	1-78	ZS-321194	ST PAN26x05STL CMT
1-17	ZS-442585	BID26x04STL CMT	1-79	BD-B344049B	LID DECORATION (B) PART
1-18	MZ-344007	RACK	1-80	BL-T2045A050A	ARM PINCH ROLLER (L) BLK
1-19	ZG-344013	SP TORSION RACK			HX-R5
1-20	ES-344104	SW LEAF BSW-191 01-1 NO	1-81	BL-T2045A060A	ARM PINCH ROLLER (R) BLK
		(SW901)			HX-R5
1-21	ZS-343125	BID14x03STL BNI	1-82	MP-336153	PINCH ROLLER (A)
1-22	HZ-344015	COVER HOUSING	1-83	ZG-344089	SP PULL PINCH ROLLER
1-23	ZS-345773	BID17x06STL BNI	1-84	ET-311977	PHOTO SENSOR SPI-201
1-24	ZS-524812	CTS20x04STL CMT	1-85	ET-310341	PHOTO SENSOR PT350 T (TR902)
1-25	ZS-608095	PAN20x05STL CMT	1-86	ZG-345660	SP TORTION RETURN (L)
1-26	HZ-344093	GUIDE TAPE	1-87	ZG-345661	SP TORTION RETURN (R)
1-27	ZW-344639A	SPACER ADJUST (A) 0.10MM	1-88	MB-349019	RUBBER ARM RETURN
1-27	ZW-344639B	SPACER ADJUST (B) 0.15MM	1-89	ZW-270088	RING E 190SUP CMT
1-27	ZW-344639C	SPACER ADJUST (C) 0.20MM	1-90	ES-344101	SW LEAF MD-1003 01-1 NO
1-27	ZW-344639D	SPACER ADJUST (D) 0.25MM			(SW905)
1-27	ZW-344639E	SPACER ADJUST (E) 0.30MM	1-91	ZG-344090	SP PULL DRIVE ARM
1-27	ZW-344639F	SPACER ADJUST (F) 0.35MM	1-92	ZG-312945	SP T1-3.2/0.29-14.0 T1-061
1-27	ZW-344639G	SPACER ADJUST (G) 0.40MM	1-93	ZW-305546	PW21x040x025PSL
1-27	ZW-344639H	SPACER ADJUST (H) 0.45MM	1-94	MR-B344076	PULLEY MIDDLE PART
1-27	ZW-344639J	SPACER ADJUST (I) 0.50MM	1-95	ZW-343120	PW17x040x025PSL
1-28	BZ-T2045A040A	GUIDE DETECTION BLK HX-R5	1-96	ED-310340	D LED GL350 INFRARED RAY
					(D902)
	<b>MECHA CMR01 BLOCK</b>		1-97	TC-344062	HOLDER STOP SENSOR
1-29	MZ-B344018	CHASSIS MECHA PART	1-98	ES-336814	SW LEAF MSW-1150NBK 01-1 NO
1-30	MI-344094	IDLER PLAY (R) ASSY			(SW902)
1-31	MI-344095	IDLER PLAY (L) ASSY	1-99	ES-344257	SW LEAF MSW-1418L 01-1 NO
1-32	MB-345139	WHEEL RUBBER			(SW903)
1-33	ZG-343195	SP PULL IDLER	1-100	ES-344253	SW LEAF MSW-1418J 01-1 NO
1-34	ZW-268222	PW31x080x030STL CMT			(SW904)
1-35	ZW-329422	RING CS0300	1-101	ES-344257	SW LEAF MSW-1418L 01-1 NO
1-36	ZG-312923	SP T1-3.2/0.2-11.2 T1-040			(SW906)
1-37	ML-344032	LEVER BRAKE (L)	1-102	ES-344253	SW LEAF MSW-1418J 01-1 NO
1-38	ML-344033	LEVER BRAKE (R)			(SW907)
1-39	MB-344034	BRAKE RUBBER	1-103	ZG-344091	SP PULL HOLDER
1-40	ZG-312925	SP T1-3.2/0.2-14.0 T1-042	1-104	MR-344080	PULLEY CAM SLIT
1-41	ZG-349016	SP PULL SLIDE	1-105	MB-B604490	Δ MOTOR OPERATION
1-42	MV-666887	BALL 250STL			(PULLEY) PART (M901)
1-43	ZG-343193	SP PULL HEAD CHASSIS RETURN	1-106	ZS-477876	PAN20x03STL CMT
1-44	MZ-344039	PLATE HEAD HOLD	1-107	MB-344088	BELT CAM
1-45	ZS-336613	PT PAN26x06STL CMT	1-108	MZ-344083	HOLDER THRUST
1-46	ZW-270088	RING E 190SUP CMT	1-109	BM-B604491	Δ MOTOR (PULLEY) PART
1-47	MZ-344036	GEAR WIND (B)			EG-510ED 2B2 (M902)
1-48	ZW-343120	PW17x040x025PSL	1-110	ZS-592378	PAN26x03STL CMT
1-49	ML-344096	ARM REWIND ASSY	1-111	ET-344102	PHOTO SENSOR GP-1S04 (PHI2)
1-50	TC-344097	WIND ASSY	1-112	ET-344102	PHOTO SENSOR GP-1S04 (PHI3)
1-51	ZW-305546	PW21x040x025PSL	1-113	EL-348214	PL LEAD 28.0V 24MA
1-52	MR-344037	PULLEY WIND	1-114	ML-344055	ARM LOCK (R)
1-53	MB-344043	BELT WIND (B)	1-115	SZ-349017	FELT CAPSTAN
1-54	ZS-353047	-SET26x03STL CMT HP	1-116	ZS-201475	PAN20x03STL NI3
1-55	ZG-344031	SP PLATE BT	1-117	ML-344056	ARM LOCK (L)
1-56	ZW-381644	PW21x040x013PSL			<b>CONTROL P.C BOARD</b>
1-57	BR-344098	REEL TABLE (A) ASSY	1-118x	ER-333698	Δ R CB H S15 FS RDS 1/2W 221J
1-58	ZW-343120	PW17x040x025PSL			(R4)
1-59	ZW-349046	WASHER FIXATION			
1-60	MZ-344019	CAM WHEEL (L)			
1-61	MZ-344020	CAM WHEEL (R)			

NOTE: Parts listed in 1 to 118 on the exploded view and list are normally stocked for replacement purpose.  
The remaining parts shown in this manual are not normally stocked, because they are not seldom required for routine service.

## 2. PRE AMP AND POWER SUPPLY P.C BOARD BLOCK

REF. NO.	PARTS NO.	DESCRIPTION
2-1U	BA-T2058A020E	PC PRE AMP/POWER BLK GX-R55 (U,J)
2-1C	BA-T2058A020G	PC PRE AMP/POWER BLK (C,A)
2-1E	BA-T2058A020H	PC PRE AMP/POWER BLK (E,B,S)
<b>PRE AMP P.C BOARD</b>		
2-IC1	EI-349196	IC HA12058
2-IC2	EI-349388	IC M54418P
2-IC4	EI-337228	IC M5218L0
2-IC5	EI-348785	IC M5220L
2-IC6to8	EI-337228	IC M5218L0
2-IC9	EI-348701	IC M51143L
2-TR3	ET-307349	Δ TR 2SD794 P,Q
2-TR5	ET-328868	TR 2SD1012-V G,H
2-TR6	ET-346298	TR 2SA1246 S,T
2-TR7,9	ET-350795	TR 2SC3399
2-TR10	ET-200558	TR 2SA1115 E,F
2-TR11,13	ET-328868	TR 2SD1012-V G,H
2-TR14	ET-349605	TR 2SA1346
2-TR15	ET-200505	TR 2SC2603 E,F
2-TR16	ET-349605	TR 2SA1346
2-TR17	ET-200505	TR 2SC2603 E,F
2-TR18	ET-328868	TR 2SD1012-V G,H
2-TR19to24	ET-349606	TR 2SC3382 T,U
2-TR27	ET-309353	Δ TR 2SC2274K E,F
2-TR28,29	ET-309353	TR 2SC2274K E,F
2-TR30	ET-349608	Δ TR 2SC3383 T,U
2-TR31	ET-328578	Δ TR 2SC2320 E,F
2-TR32	ET-337968	TR 2SA999 E,F
2-TR33	ET-349592	TR 2SC3400
2-TR34	ET-200505	TR 2SC2603 E,F
2-TR35	ET-328868	Δ TR 2SD1012-V G,H
2-TR37	ET-352726	TR 2SA1392 T,U
2-D5to7	ED-344280	D SILICON H GMA-01-FY2 F05
2-D8	ED-301911	D SILICON H DS448
2-D9	ED-346440	D ZENER H HZ5FA F10 B1
2-D10	ED-308953	D GERMA H 1K34A-LH S12
2-D11	ED-301911	D SILICON H DS448
2-D12	ED-348062	Δ D ZENER V HZ15-2S7
2-D13	ED-301911	D SILICON H DS448
2-D14	ED-344280	D SILICON H GMA-01-FY2 F05
2-D15,16	ED-301911	D SILICON H DS448
2-VR1	EV-342939	R S-FIX H H0811C313A 3P 103
2-VR2	EV-345610	R S-FIX H H0811C307A 3P 102
2-VR3	EV-345611	R S-FIX H H0811C358A 3P 502
2-VR4	EV-342939	R S-FIX H H0811C313A 3P 103
2-VR5,6	EV-342942	R S-FIX H H0811C362A 3P 503
2-VR7	EV-336785	R S-FIX H TM8KV2-1S 3P 0.50W
2-RL1	EQ-337067	RELAY LEAD LAB3NS 2NO 104 18V
2-VL1	EO-337055	COIL VARI 1 FE002S 10MH
2-L1	EO-669273	COIL FIX 2 FL5R200 180
2-T1	EO-352104	COIL OSC 1 94-5009-01 100KHZ
2-FL1	EH-351182	FILTER DB 201AK-005 100KHZ
2-FL2	EH-351183	FILTER DB 201AK-006 19KHZ
2-FL3	EO-337044	COIL TUN 1 102AK-005
2-FL4	EO-315758	COIL TUN 1 100Z-431 100.00KHZ
2-C3	EC-347187	C MC V F05 FM 5R0D 500DC
2-C5	EC-200948	C EC V F05 NP SM 1R0M 50DC
2-C35	EC-314992	C STY V F05 CQF09 681J 50DC
2-C36	EC-347205	C MC V F05 FM 220J 500DC
2-C46	EC-306419	C STY V F05 500 681J 50DC
2-C55	EC-347216	C MC V F05 FM 330J 500DC
2-C64	EC-347187	C MC V F05 FM 5R0D 500DC
2-C67	EC-308965	C STY V F05 CQ09S 152J 500DC
2-C71	EC-307684	C EC V F05 NP SM R47M 50DC
2-C72	EC-307167	C EC V F05 LL 100 16.0DC
2-C74	EC-347400	C MC V F05 FE92 680J 500DC
2-C75	EC-347471	C PP V F05 PP 471J 50DC
2-J1	EJ-347664	PIN J YKC21-5053 P 4P

REF. NO. PARTS NO. DESCRIPTION

### JACK P.C BOARD

2-J1B	EJ-345812	PHONE J HLJ0527-3714
2-J2B	EJ-344640	PHONE J HLJ4308-3034

### OUTPUT P.C BOARD

2-VRIC	EV-337841	VR SLIDE 30P2SV0A B103
--------	-----------	------------------------

### POWER SUPPLY P.C BOARD

2-TR1D	ET-200505	Δ TR 2SC2603 E,F
2-TR2D	ET-200558	TR 2SA1115 E,F
2-TR3D	ET-309353	Δ TR 2SC2274K E,F
2-TR4D	ET-310148	Δ TR 2SD612K E,F
2-TR5D	ET-349081	Δ TR 2SC3383 S,T
2-TR6D	ET-349979	Δ TR 2SD794 P,Q,R
2-TR7D	ET-349718	Δ TR 2SA1392 S,T
2-TR8D	ET-353067	Δ TR 2SB744 P,Q,R
2-D1D	ED-330319	Δ D SILICON DBA10B 100/1.0A
2-D2D	ED-349662	Δ D SILICON DS135E-FA6 100/1.0A
2-D3D	ED-346450	D ZENER H HZ6FA F10 B2
2-D4D	ED-344280	D SILICON H GMA-01-FY2 F05
2-D5D	ED-338092	D ZENER H HZ2FA F10 B1
2-D6D	ED-346454	D ZENER H HZ6FA F10 C3
2-D7D	ED-346454	Δ D ZENER H HZ6FA F10 C3
2-D8D	ED-330319	Δ D SILICON DBA10B 100/1.0A
2-D9D,10D	ED-349662	Δ D SILICON DS135E-FA6 100/1.0A
2-D11D	ED-344280	D SILICON H GMA-01-FY2 F05
2-D12D	ED-346264	Δ D ZENER V HZ11LS7 F05 B2
2-D13D	ED-349662	Δ D SILICON DS135E-FA6 100/1.0A
2-D14D	ED-346446	D ZENER H HZ5FA F10 C3
2-D15D	ED-344280	D SILICON H GMA-01-FY2 F05
2-D16D	ED-346264	Δ D ZENER V HZ11LS7 F05 B2
2-D17D,19D	ED-344280	D SILICON H GMA-01-FY2 F05
2-D20D,21D	ED-301911	D SILICON H DS448
2-SW1D	ES-344270	Δ SW PUSH SDDL1P 01-1
2-C1D	EC-338396	Δ C MMY V ECQEW 473M 250AC

### REMOTE P.C BOARD

2-J2E	EJ-346076	DIN J TCS4690-01-1111 P 8P
-------	-----------	----------------------------

## 3. SYSTEM CONTROL AND METER P.C BOARD BLOCK

REF. NO.	PARTS NO.	DESCRIPTION
3-1	BA-T2058A030C	PC SYSCON/METER BLK GX-R55
3-1B	BA-T2058A030F	PC SYSCON/METER BLK GX-R55-B (BL MOD EL)
<b>SYSTEM CONTROL P.C BOARD</b>		
3-IC1	EI-349877	IC T2055A
3-IC2,3	EI-337008	IC LC7800
3-IC4	EI-337009	IC LC4049B
3-IC5	EI-345759	IC LC7530
3-IC6	EI-330352	IC BA6109
3-IC7	EI-345765	IC LB1292
3-TR1,2	ET-349592	TR 2SC3400
3-TR3	ET-348950	TR 2SA1345
3-TR4	ET-349592	TR 2SC3400
3-TR5	ET-200505	TR 2SC2603 E,F
3-TR6	ET-200558	TR 2SA1115 E,F
3-TR7,8	ET-200505	TR 2SC2603 E,F
3-TR9	ET-349272	Δ TR 2SC3242A E,F
3-TR11,12	ET-200505	TR 2SC2603 E,F
3-D1	ED-349662	D SILICON DS135E-FA6 100/1.0A

3-D2	ED-344280	D SILICON H GMA-01-FY2 F05
3-D3	ED-346504	Δ D ZENER H HZ20FA F10 3
3-D5	ED-338454	D ZENER V HZ9C-2S7
3-D6	ED-349662	D SILICON DS135E-FA6
		100/1.0A
3-D7,8	ED-349662	D SILICON DS135E-FA6
		100/1.0A (BL MODEL)
3-D9	ED-344280	D SILICON H GMA-01-FY2 F05
3-D13	ED-624903	D SILICON H 1S2473
3-D14	ED-346469	D ZENER H H29FA F10 B2
3-D15	ED-344280	D SILICON H GMA-01-FY2 F05
3-D16	ED-346455	D ZENER H HZ27FA F10 AJ
3-VR1	EV-522652	R S-FIX V V8K1-1 3P 105
3-X1	EI-349372	OSC CE CSA4.00MG 4MHZ
3-CR2	EH-349374	COMP R RKC1/8B8 4.7K J
3-CR3	EH-349375	COMP R M3806
3-C5	EC-200983	C STY V F05 500 101K 50DC
3-C14	EC-346299	C EC V CUT LL 102M 16DC

**METER P.C BOARD**

3-IC1B	EI-337013	IC LB1290
3-IC3B,4B	EI-337845	IC BA6146 M
3-IC5B,6B	EI-343417	IC LB1294
3-TR1B	ET-349592	TR 2SC3400
3-TR2B	ET-349593	TR 2SA1348
3-D1Bto3B	ED-624903	D SILICON H 1S2473
3-SW1Bto8B	ES-349367	SW TACT KHH10906
3-SW9B	ES-349640	SW TACT B3F-1050
3-SW10Bto30B	ES-349367	SW TACT KHH10906
3-SW31B	ES-349698	SW SLIDE 00130333 GRAY
		01-3 S (EXCEPT BL MODEL)
3-SW31B	ES-349597	SW SLIDE 00130329 BLACK
		01-3 S (BL MODEL)
3-SW32B,33B	ES-347966	SW PUSH ESB-649 01-2-2 N
3-SW34B	ES-347966	SW PUSH ESB-649 01-2-2 N
3-IN1B	EM-349594	IND FL FIP6GM7
3-IN2B	EM-349595	IND FL FIP48AW11YS

**ASSEMBLY BLOCK**

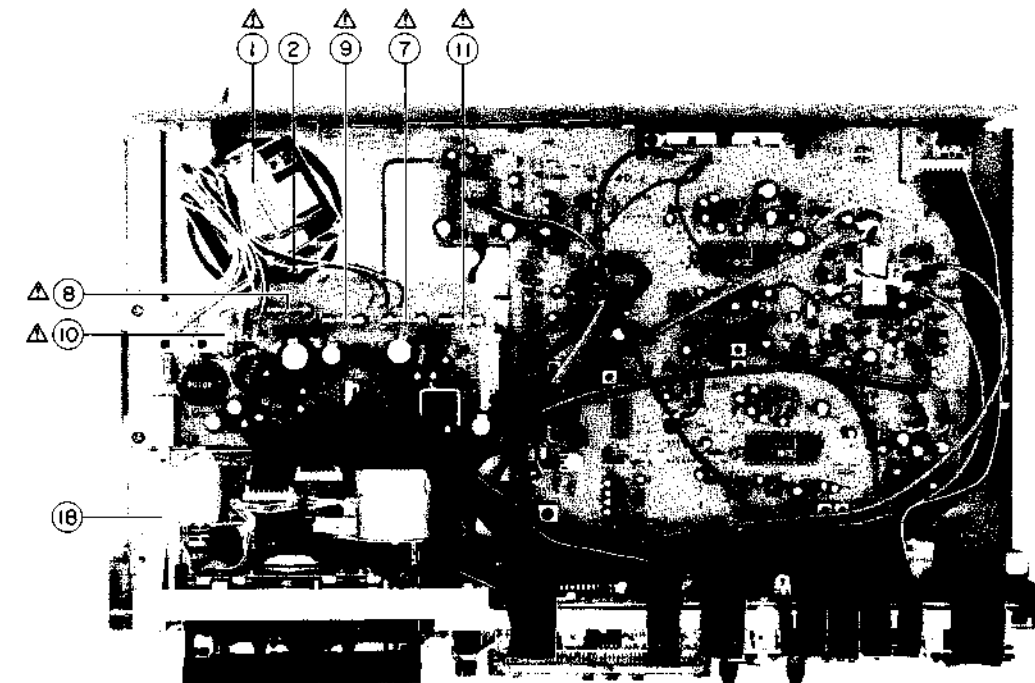
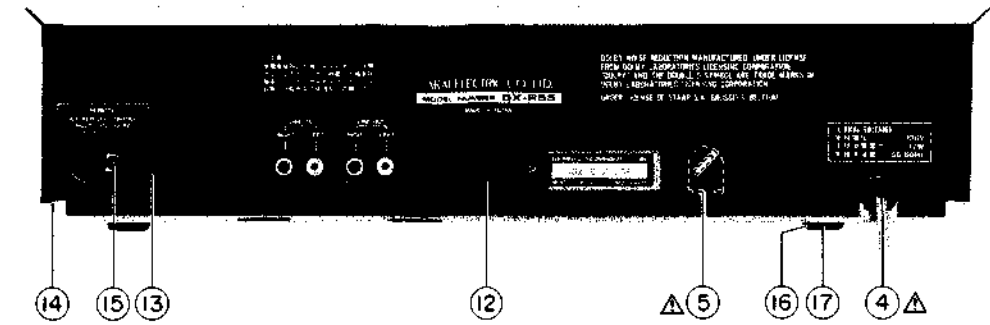

**4. ASSEMBLY BLOCK**

REF. NO.	PARTS NO.	DESCRIPTION	REF. NO.	PARTS NO.	DESCRIPTION	REF. NO.	PARTS NO.	DESCRIPTION
4-1U	BT-349618	Δ TRANS POWER T2059(U) (T901)	4-6x	ZS-348375	ST BR30x08STL CMT (U)	4-11U	EF-327103	Δ FUSE TSC A 250V 0.50A (F5)(U,J)
4-1J	BT-349619	Δ TRANS POWER T2059(J) (T901)(EXCEPT P MODEL)	4-7U	EF-327103	Δ FUSE TSC A 250V 0.50A (F1)(U,J)	4-11C	EF-309390	Δ FUSE TSC 125V 0.50A (F5) (C,A)
4-1C	BT-349620	Δ TRANS POWER T2059(A,C) (T901)	4-7C	EF-309390	Δ FUSE TSC 125V 0.50A (F1)(C,A)	4-11E	EF-668474	Δ FUSE SEMKO T 250V 0.40A (F5)(E,B,S)
4-1E	BT-349621	Δ TRANS POWER T2059(E,V) (T901)	4-7E	EF-668474	Δ FUSE SEMKO T 250V 0.40A (F1)(E,B,S)	4-12U	SP-351185G	PANEL REAR BOARD GX-R55(U)
4-1B	BT-349622	Δ TRANS POWER T2059(B,S) (T901)	4-8U	EF-327103	Δ FUSE TSC A 250V 0.50A (F2)(U,J)	4-12J	SP-351185H	PANEL REAR BOARD GX-R55(J) (EXCEPT P MODEL)
4-2	ZS-314702	ST BID40x10STL CMT	4-8C	EF-309390	Δ FUSE TSC 125V 0.50A (F2)(C,A)	4-12C	SP-351185J	PANEL REAR BOARD GX-R55(A,C)
4-3x	ZW-413188	N40STL CMT 1	4-8E	EF-593706	Δ FUSE SEMKO T 250V 0.50A (F2)(E,B,S)	4-12E	SP-351185K	PANEL REAR BOARD GX-R55(E)
4-4U	EW-347683	Δ AC CORD 2 CORES VM0129, VFF-CB U/T (U)	4-9U	EF-306125	Δ FUSE TSC A 250V 0.31A (F3)(U,J)	4-12B	SP-351185M	PANEL REAR BOARD GX-R55(B,S)
4-4J	EW-347836	Δ AC CORD 2 CORES KP-209 VFF-CB J (J)(EXCEPT P MODEL)	4-9C	EF-308848	Δ FUSE TSC 125V 0.40A (F3)(C,A)	4-13	ZS-352120	T2BR30x08STL BCM C080
4-4C	EW-348215	Δ AC CORD 2 CORES KP10, SPT1 105C CB UC(C,A)	4-9E	EF-339906	Δ FUSE SEMKO T 250V 0.25A (F3)(E,B,S)	4-14	ZS-455207	T2BR30x055STL CMT
4-4E	EW-347682	Δ AC CORD 2 CORES VM0364, FC3097-CB EV (E)	4-10U	EF-309388	Δ FUSE TSC A 250V 0.80A (F4)(U,J)	4-15	ZW-698308	RV NYL30x055 BL
4-4B	EW-347680	Δ AC CORD 2 CORES LCFL2x0.75-CB B (B)	4-10C	EF-309391	Δ FUSE TSC 125V 0.80A (F4) (C,A)	4-16	SA-349332	FOOT
4-4S	EW-347681	Δ AC CORD 2 CORES VM0436, FC3093-CB S (S)	4-10E	EF-593706	Δ FUSE SEMKO T 250V 0.50A (F4)(E,B,S)	4-17	ZS-313486	ST PAN30x06STL CMT C
4-5	ES-305733	Δ SW SELECTOR HXW0131-260 01-4 (U)				4-18	MZ-349534	JOINT POWER
						4-19x	ZW-305013	RV POP32 (A)

**FINAL ASSEMBLY BLOCK**

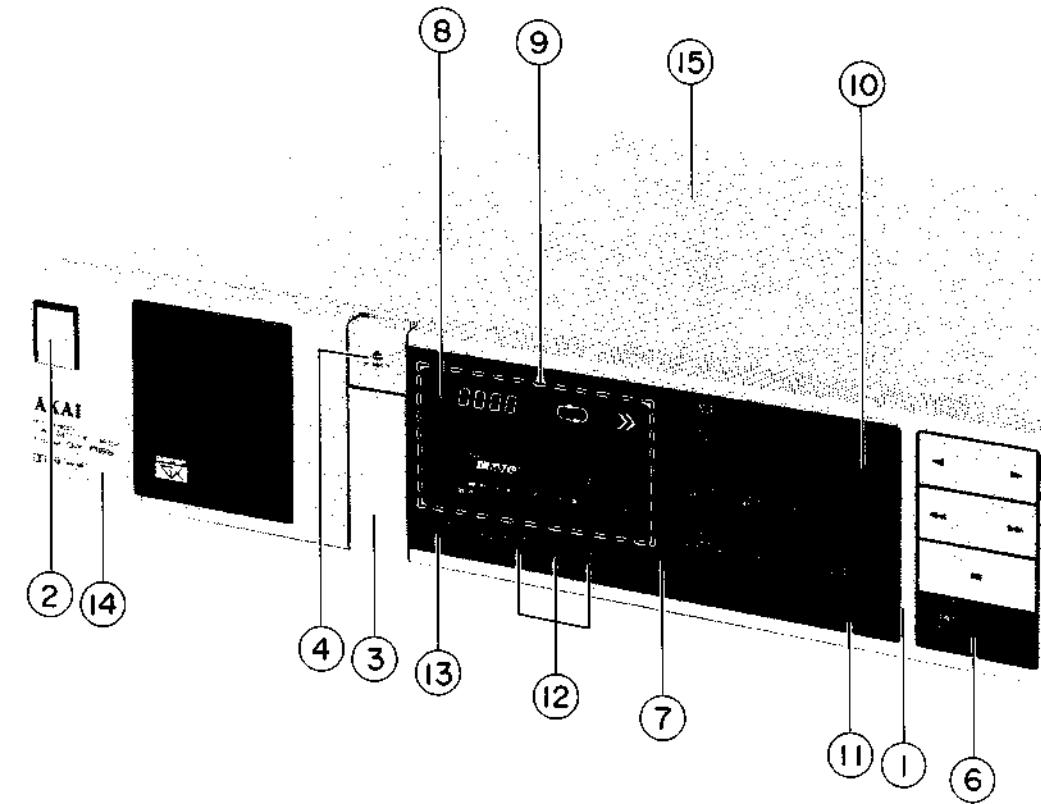

**5. FINAL ASSEMBLY BLOCK**

REF. NO.	PARTS NO.	DESCRIPTION	REF. NO.	PARTS NO.	DESCRIPTION
5-1	BD-T2058A050D	PANEL FRONT BLK GX-R55	5-11	SK-343009E	KNOB OUTPUT-P2
5-1P	BD-T2058A050E	PANEL FRONT BLK GX-R55-P (EXCEPT J MODEL)	5-11B	SK-343009C	KNOB OUTPUT-B
5-1B	BD-T2058A050F	PANEL FRONT BLK GX-R55-B	5-12	SK-349518A	KNOB DOLBY
5-2	SK-343017G	KNOB POWER	5-12B	SK-349518B	KNOB DOLBY-B
5-2P	SK-34017B	KNOB POWER-P	5-13	SK-349512A	KNOB RESET
5-2B	SK-343017F	KNOB POWER-B	5-13B	SK-349512B	KNOB RESET-B
5-3	SP-349517A	PANEL DOOR	5-14	BD-B349521C	LID PANEL(2) PART
5-3P	SP-349517B	PANEL DOOR-P	5-14P	BD-B349521D	LID PANEL(2)-P PART
5-3B	SP-349517C	PANEL DOOR-B	5-14B	BD-B349521N	LID PANEL(2)-B PART
5-4	SK-349513A	KNOB EJECT	5-15	SP-344591A	COVER UPPER
5-4P	SK-349513B	KNOB EJECT-P	5-15P	SP-344591B	COVER UPPER P
5-4B	SK-349513C	KNOB EJECT-B	5-15B	SP-344591D	COVER UPPER-B(2)
5-5x	ZG-313182	SP C-4.5/0.35-25.0 C-029			
5-6	SK-349516G	KNOB OPERATE(D)			
5-6B	SK-349516L	KNOB OPERATE(D)-B			
5-7	SP-B349524	PANEL TEN KEY(A) PART			
5-7B	SP-B349524B	PANEL TEN KEY(A)-2 PART			
5-8	SP-349502B	WINDOW METER(2)			
5-8B	SP-349520E	WINDOW METER(2)			
5-9	SE-353076	WIND FILTER			
5-10	SK-349519B	KNOB RANDOM-P			
5-10B	SK-349519C	KNOB RANDOM-B			

**SYMBOL FOR COLOR VARIATION**

- S — SILVER
- P — PEARL SHADOW
- B or BL — BLACK



# INDEX

PARTS NO.	REF. NO.	PARTS NO.	REF. NO.	PARTS NO.	REF. NO.	PARTS NO.	REF. NO.
BA-T2058A020E	2-1U	ED-349662	2-D9D	ES-349367	3-SW4B	ET-350795	2-TR9
BA-T2058A020G	2-1C	ED-349662	2-D10D	ES-349367	3-SW5B	ET-352726	2-TR37
BA-T2058A020H	2-1E	ED-349662	2-D13D	ES-349367	3-SW6B	ET-353067	2-TR8D
BA-T2058A030C	3-1	ED-349662	3-D1	ES-349367	3-SW7B	EV-336785	2-VR7
BA-T2058A030F	3-1B	ED-349662	3-D6	ES-349367	3-SW8B	EV-337841	2-VR1C
BB-T2045A020B	1-1	ED-349662	3-D7	ES-349367	3-SW10B	EV-342939	2-VR1
BD-B344049B	1-79	ED-349662	3-D8	ES-349367	3-SW11B	EV-342939	2-VR4
BD-B349521C	5-14	ED-624903	3-D13	ES-349367	3-SW12B	EV-342942	2-VR5
BD-B349521D	5-14P	ED-624903	3-D1B	ES-349367	3-SW13B	EV-342942	2-VR6
BD-B349521N	5-14B	ED-624903	3-D2B	ES-349367	3-SW14B	EV-345610	2-VR2
BD-T2058A050D	5-1	ED-624903	3-D3B	ES-349367	3-SW15B	EV-345611	2-VR3
BD-T2058A050E	5-1P	EF-306125	4-9U	ES-349367	3-SW16B	EV-522652	3-VR1
BD-T2058A050F	5-1B	EF-308848	4-9C	ES-349367	3-SW17B	EW-347680	4-4B
BF-344029	1-64	EF-309388	4-10U	ES-349367	3-SW18B	EW-347681	4-4S
BH-T2045A030B	1-2	EF-309390	4-7C	ES-349367	3-SW19B	EW-347682	4-4E
BL-T2045A050A	1-80	EF-309390	4-8C	ES-349367	3-SW20B	EW-347683	4-4U
BL-T2045A060A	1-81	EF-309390	4-11C	ES-349367	3-SW21B	EW-347836	4-4J
BM-B604490	1-105	EF-309391	4-10C	ES-349367	3-SW22B	EW-348215	4-4C
BM-B604491	1-109	EF-327103	4-7U	ES-349367	3-SW23B	HR-H2501A010A	1-6
BR-344098	1-57	EF-327103	4-8U	ES-349367	3-SW24B	HZ-B344006	1-5
BY-349618	4-10	EF-327103	4-11U	ES-349367	3-SW25B	HZ-B344009	1-4
BT-349619	4-1J	EF-339906	4-9E	ES-349367	3-SW26B	HZ-344011	1-9
BT-349620	4-1C	EF-593706	4-8E	ES-349367	3-SW27B	HZ-344015	1-22
BT-349621	4-1E	EF-593706	4-10E	ES-349367	3-SW28B	HZ-344093	1-26
BT-349622	4-1B	EF-668474	4-7E	ES-349367	3-SW29B	MB-344028	1-67
BZ-T2045A040A	1-28	EF-668474	4-11E	ES-349367	3-SW30B	MB-344034	1-39
EA-343944	1-7	EH-349374	3-CR2	ES-349597	3-SW31B	MB-344041	1-68
EC-200948	2-C5	EH-349375	3-CR3	ES-349640	3-SW9B	MB-344042	1-69
EC-200983	3-C5	EH-351182	2-FL1	ES-349698	3-SW31B	MB-344043	1-53
EC-306419	2-C46	EH-351183	2-FL2	ET-200505	2-TR15	MB-344088	1-107
EC-307167	2-C72	EI-330352	3-IC6	ET-200505	2-TR17	MB-345139	1-32
EC-307684	2-C71	EI-337008	3-IC2	ET-200505	2-TR34	MB-349019	1-88
EC-308965	2-C67	EI-337008	3-IC3	ET-200505	2-TR1D	MI-344094	1-30
EC-314992	2-C35	EI-337009	3-IC4	ET-200505	3-TR7	MI-344095	1-31
EC-338396	2-C1D	EI-337013	3-IC1B	ET-200505	3-TR8	ML-344032	1-37
EC-346299	3-C14	EI-337228	2-IC4	ET-200505	3-TR11	ML-344033	1-38
EC-347187	2-C3	EI-337228	2-IC6	ET-200505	3-TR12	ML-344053	1-77
EC-347187	2-C64	EF-337228	2-IC7	ET-200505	3-TR5	ML-344055	1-114
EC-347205	2-C36	EI-337228	2-IC8	ET-200558	2-TR10	ML-344056	1-117
EC-347216	2-C55	EI-337845	3-IC3B	ET-200558	2-TR2D	ML-344096	1-49
EC-347400	2-C74	EI-337845	3-IC4B	ET-200558	3-TR6	ML-344286	1-76
EC-347471	2-C75	EI-343417	3-IC5B	ET-307349	2-TR3	MP-336153	1-82
ED-301911	2-D8	EI-343417	3-IC6B	ET-309353	2-TR27	MR-B344076	1-94
ED-301911	2-D11	EI-345759	3-IC5	ET-309353	2-TR28	MR-344037	1-52
ED-301911	2-D13	EI-345765	3-IC7	ET-309353	2-TR29	MR-344080	1-104
ED-301911	2-D15	EI-348701	2-IC9	ET-309353	2-TR3D	MV-666887	1-42
ED-301911	2-D16	EI-348785	2-IC5	ET-310148	2-TR4D	MZ-B344008	1-3
ED-301911	2-D20D	EI-349196	2-IC1	ET-310341	1-85	MZ-B344018	1-29
ED-301911	2-D21D	EI-349372	3-X1	ET-311977	1-84	MZ-344002	1-16
ED-308953	2-D10	EI-349388	2-IC2	ET-328578	2-TR31	MZ-344004	1-12
ED-310340	1-96	EI-349877	3-IC1	ET-328868	2-TR5	MZ-344007	1-18
ED-330319	2-D1D	EJ-344640	2-2B	ET-328868	2-TR11	MZ-344019	1-60
ED-330319	2-D8D	EJ-345812	2-21B	ET-328868	2-TR13	MZ-344020	1-61
ED-338092	2-D5D	EJ-346076	2-22E	ET-328868	2-TR18	MZ-344036	1-47
ED-338454	3-D5	EJ-347664	2-21	ET-328868	2-TR35	MZ-344039	1-44
ED-344280	2-D6	EL-348214	1-113	ET-337968	2-TR32	MZ-344083	1-108
ED-344280	2-D7	EM-349594	3-IN1B	ET-344102	1-111	MZ-344099	1-70
ED-344280	2-D5	EM-349595	3-IN2B	ET-344102	1-112	MZ-349534	4-18
ED-344280	2-D14	EO-315758	2-FL4	ET-346298	2-TR6	SA-349332	4-16
ED-344280	2-D4D	EO-337044	2-FL3	ET-348950	3-TR3	SP-351185H	4-12J
ED-344280	2-D11D	EO-337055	2-VL1	ET-349081	2-TR5D	SE-353076	5-9
ED-344280	2-D17D	EO-352104	2-T1	ET-349272	3-TR9	SK-343009C	5-11B
ED-344280	2-D18D	EO-669273	2-L1	ET-349592	2-TR33	SK-343009E	5-11
ED-344280	2-D19D	EQ-337067	2-RL1	ET-349592	3-TR1B	SK-343017F	5-2P
ED-344280	2-D15D	ER-333698	1-118x	ET-349592	3-TR1	SK-343017B	5-2B
ED-344280	3-D2	ES-305733	4-5	ET-349592	3-TR2	SK-343017G	5-2
ED-344280	3-D9	ES-336814	1-98	ET-349592	3-TR4	SK-349512A	5-13
ED-344280	3-D15	ES-344101	1-90	ET-349593	3-TR2B	SK-349512B	5-13B
ED-346264	2-D12D	ES-344104	1-20	ET-349605	2-TR14	SK-349513A	5-4
ED-346264	2-D16D	ES-344253	1-100	ET-349605	2-TR16	SK-349513B	5-4P
ED-346440	2-D9	ES-344253	1-102	ET-349606	2-TR19	SK-349513C	5-4B
ED-346446	2-D14D	ES-344257	1-99	ET-349606	2-TR21	SK-349516G	5-6
ED-346450	2-D3D	ES-344257	1-101	ET-349606	2-TR22	SK-349516L	5-6B
ED-346454	2-D6D	ES-344270	2-SW1D	ET-349606	2-TR23	SK-349518A	5-12
ED-346454	2-D7D	ES-347966	3-SW33B	ET-349606	2-TR24	SK-349518B	5-12B
ED-346455	3-D16	ES-347966	3-SW34B	ET-349606	2-TR20	SK-349519B	5-10
ED-346469	3-D14	ES-347966	3-SW32B	ET-349608	2-TR30	SK-349519C	5-10B
ED-346504	3-D3	ES-349367	3-SW1B	ET-349718	2-TR7D	SP-B349524	5-7
ED-348062	2-D12	ES-349367	3-SW2B	ET-349979	2-TR6D	SP-B349524B	5-7B
ED-349662	2-D2D	ES-349367	3-SW3B	ET-350795	2-TR7	SP-344057	1-72

# INDEX

PARTS NO.	REF. NO.	PARTS NO.	REF. NO.	PARTS NO.	REF. NO.	PARTS NO.	REF. NO.
SP-344591A	5-15	ZW-618884	1-14				
SP-344591B	5-15P	ZW-698308	4-15				
SP-344591D	5-15B						
SP-349517A	5-3						
SP-349517B	5-3P						
SP-349517C	5-3B						
SP-349520B	5-8						
SP-349520E	5-8B						
SP-351185G	4-12U						
SP-351185J	4-12C						
SP-351185K	4-12E						
SP-351185M	4-12B						
SZ-349017	1-115						
TC-344062	1-97						
TC-344097	1-50						
ZG-312923	1-36						
ZG-312925	1-40						
ZG-312945	1-92						
ZG-313182	5-5x						
ZG-336615	1-73						
ZG-343193	1-43						
ZG-343195	1-33						
ZG-344012	1-13						
ZG-344013	1-19						
ZG-344031	1-55						
ZG-344058A	1-75						
ZG-344064	1-63						
ZG-344089	1-83						
ZG-344090	1-91						
ZG-344091	1-103						
ZG-344939	1-74						
ZG-345660	1-86						
ZG-345661	1-87						
ZG-349016	1-41						
ZS-201475	1-116						
ZS-245147	1-8						
ZS-313486	4-17						
ZS-314702	4-2						
ZS-321194	1-78						
ZS-336613	1-62						
ZS-336613	1-45						
ZS-343113	1-71						
ZS-343125	1-21						
ZS-344001	1-10						
ZS-345773	1-23						
ZS-348375	4-6x						
ZS-352120	4-13						
ZS-353047	1-54						
ZS-442585	1-17						
ZS-455207	4-14						
ZS-477876	1-106						
ZS-524812	1-24						
ZS-592378	1-110						
ZS-608095	1-25						
ZW-268222	1-34						
ZW-270088	1-89						
ZW-270088	1-46						
ZW-273734	1-11						
ZW-305013	4-19x						
ZW-305546	1-93						
ZW-305546	1-51						
ZW-329422	1-35						
ZW-343120	1-58						
ZW-343120	1-95						
ZW-343120	1-48						
ZW-344047	1-65						
ZW-344639A	1-27						
ZW-344639B	1-27						
ZW-344639C	1-27						
ZW-344639D	1-27						
ZW-344639E	1-27						
ZW-344639F	1-27						
ZW-344639G	1-27						
ZW-344639H	1-27						
ZW-344639J	1-27						
ZW-349046	1-59						
ZW-349047	1-66						
ZW-381644	1-56						
ZW-391297	1-15						
ZW-413188	4-3x						

---

**AKAI**

**MODEL GX-R55**

**P.C BOARDS  
SCHEMATIC DIAGRAM**

**BA6109**

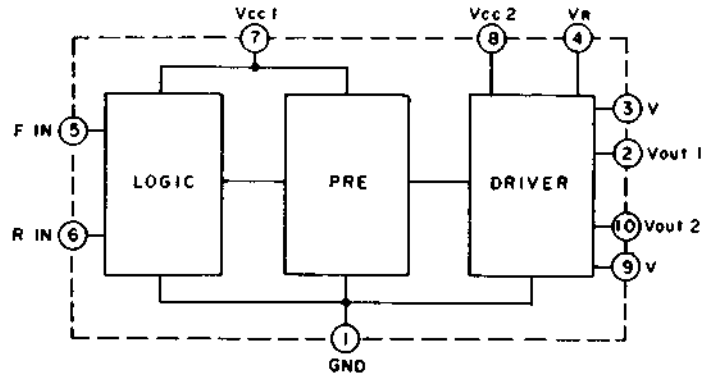

**BA6146**

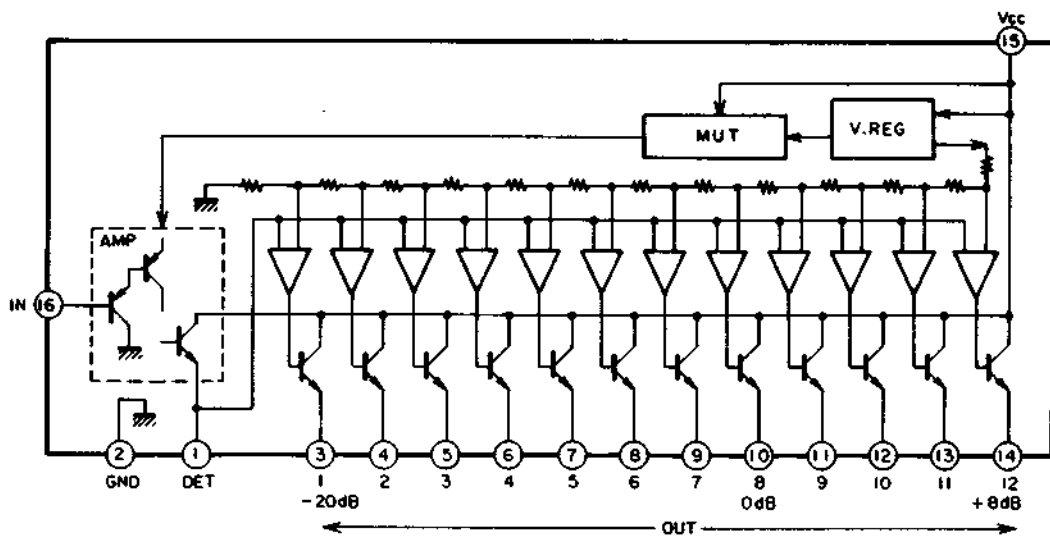

**LC7530**

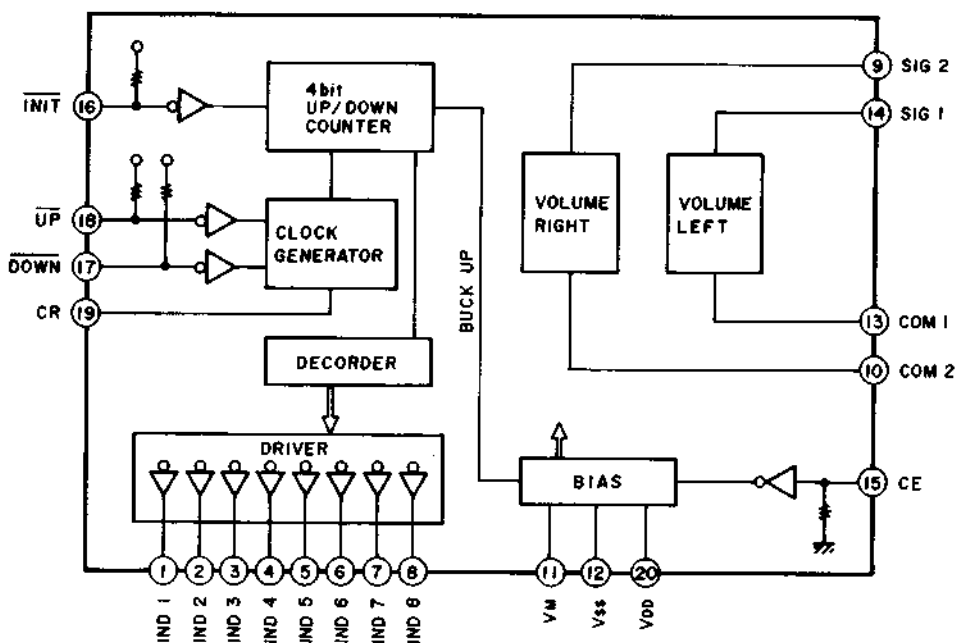

LC7800

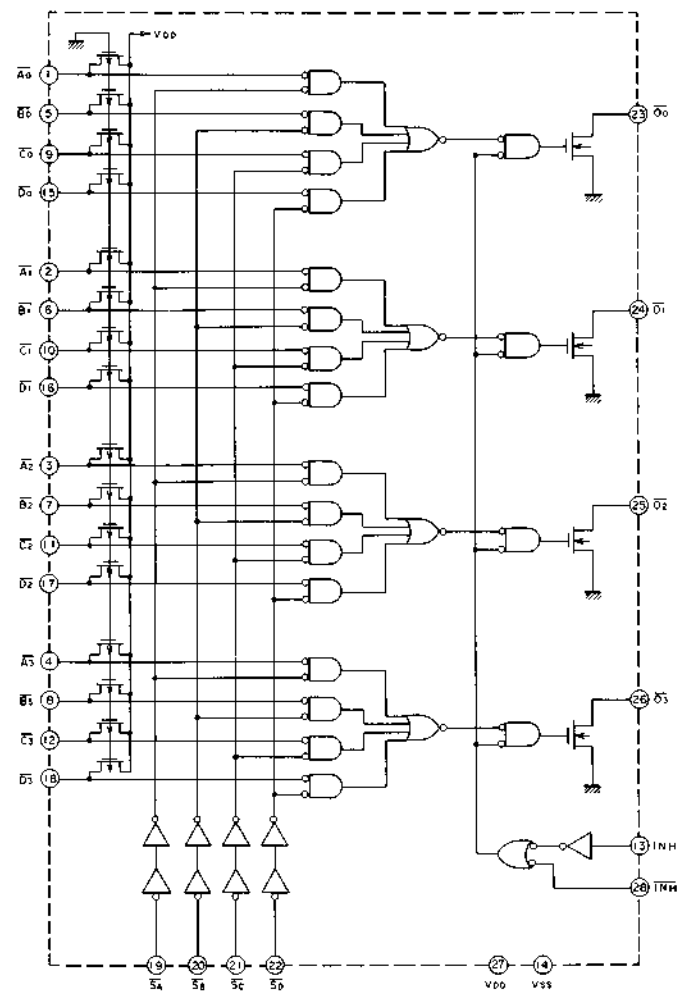

M51143L

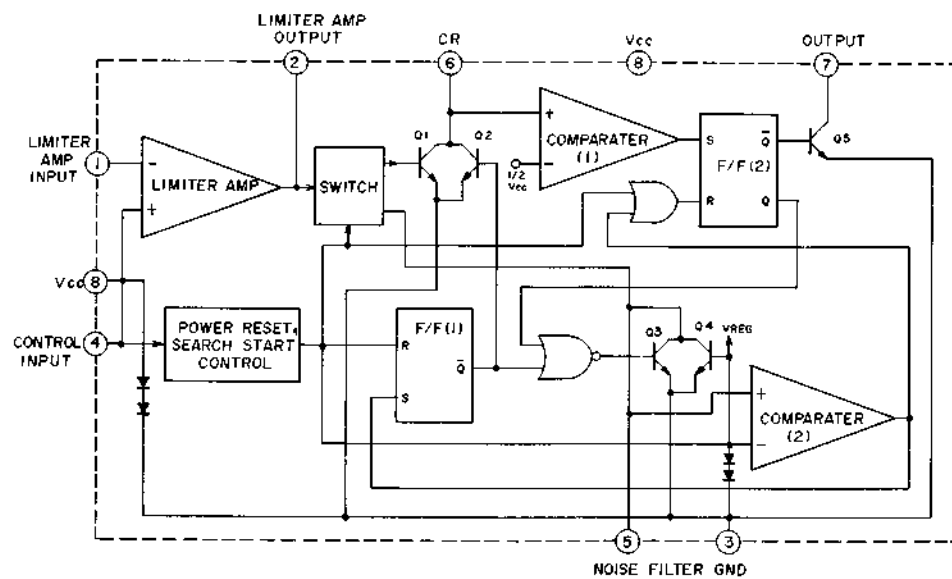

T2055A

Pin No.	Symbol	Description
1	R40	REC MUTE } Output, activated at "H"
2	R41	P. B MUTE } Output, activated at "H"
3	R42	REC/PB Control, "H"→PB, "L"→REC
4	R43	OSC Control output, activates at "L"
5	R50	Forward } Cam Motor Control Output
6	R51	Reverse } Cam Motor Control Output
7	R52	IPLS FLD Drive output, Lights at "L"
8	R53	COMMON BUS Output Not used
9	R60	} Electronic Counter Digit Drive Output
10	R61	
11	R62	
12	R64	
13	R70	} STROBE for input port select } "H" at inhibit
14	R71	
15	R72	INHIBIT
16	R73	FLD Drive output, Lights at "L"
17	P10	FWD } FLD Drive output, Light at "H"
18	P11	REV } FLD Drive output, Light at "H"
19	P12	REC } FLD Drive output, Light at "H"
20	P13	R. PLAY
21	V <sub>SS</sub>	GND
22	P20	ONCE REV } FLD Drive output, Light at "H"
23	P21	CONTI. REV } FLD Drive output, Light at "H"
24	P22	INTRO } FLD Drive output, Light at "H"
25	P23	BSP } FLD Drive output, Light at "H"
26	K00	} DATA input
27	K01	
28	K02	
29	K03	
30	TEST	GND
31	XTAL	Ceramic OSC input
32	EXTAL	Ceramic OSC output
33	RESET	Reset
34	V <sub>III</sub>	+5V
35	R80	Counter Pulse
36	R81	CAM Motor Pulse
37	R82	COMMON BUS input Not used
38	R83	CAM MOTOR direction detector input
39	R90	IPLS Signal detector input "H" at No signal parts
40	R91	TEST ENABLE
41	R92	CAM MODE Stop Detector input "L" at stop mode
42	V <sub>DD</sub>	+5V

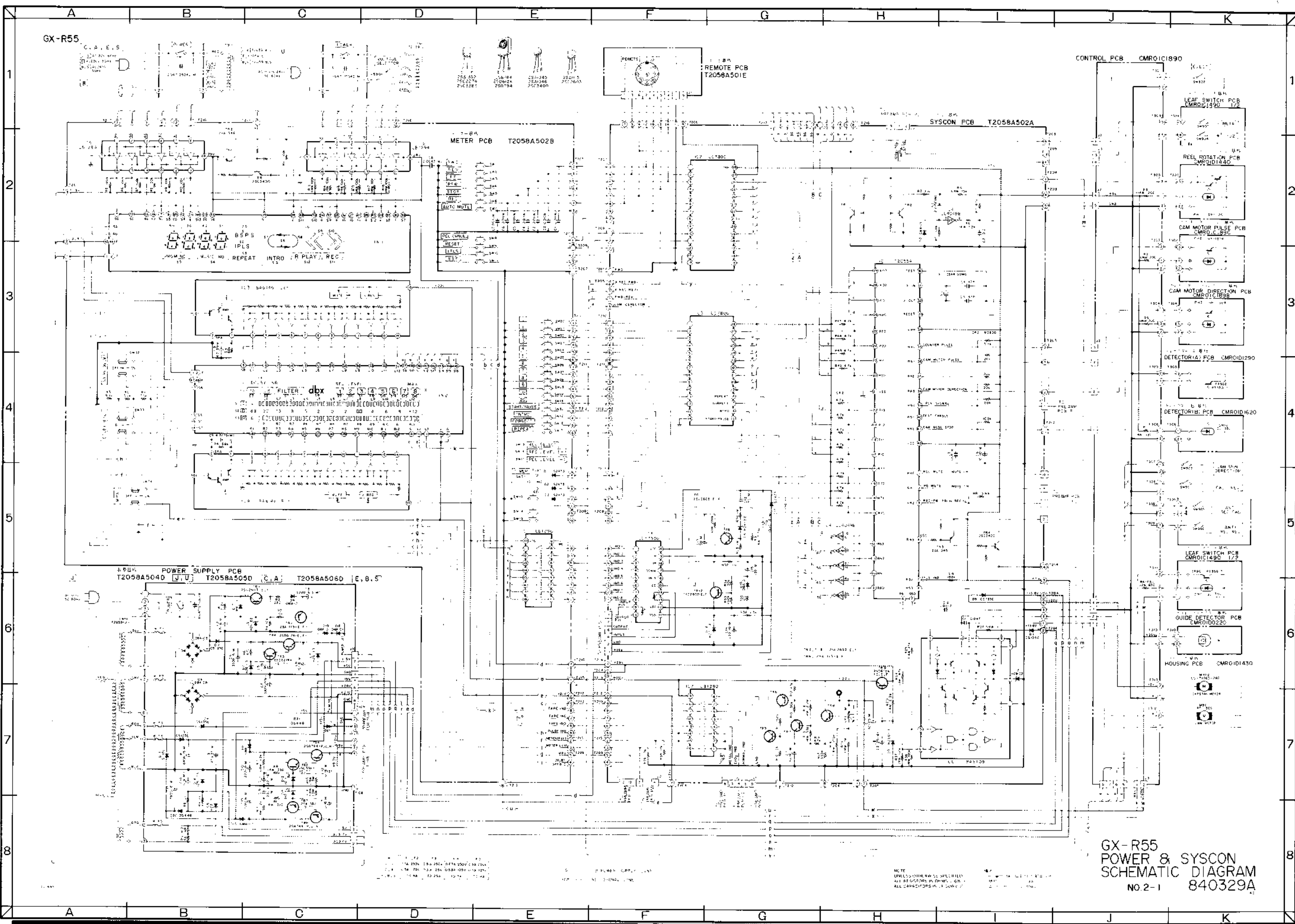

メーター基板  
METER PCB  
T2058A502B

TR1----2SC3400  
TR2----2SA1348

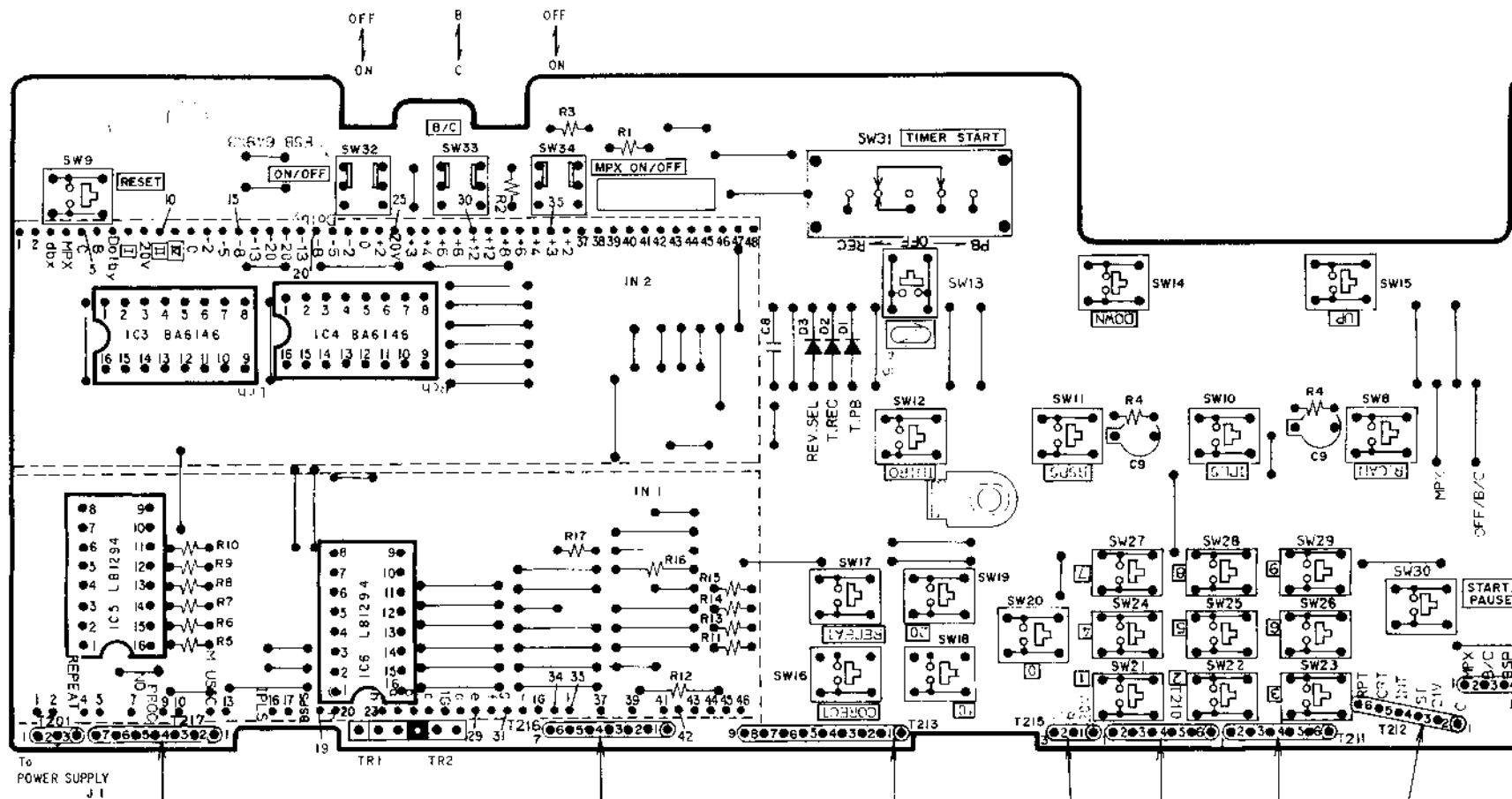

システム コントロール基板  
SYSTEM CONTROL PCB  
T2058A502A

TR1, 2, 4-----2SC3400  
TR3-----2SA1348  
TR5, 7, 8, 11, 12---2SC2603(E, F)  
TR6-----2SA1115(E, F)  
TR9-----2SD612K(D, E, F)

= PNP TRANSISTOR  
 = NPN TRANSISTOR

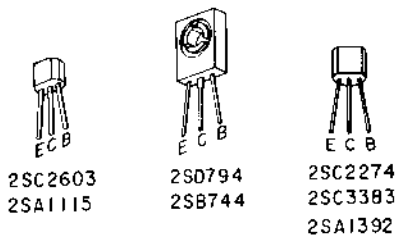
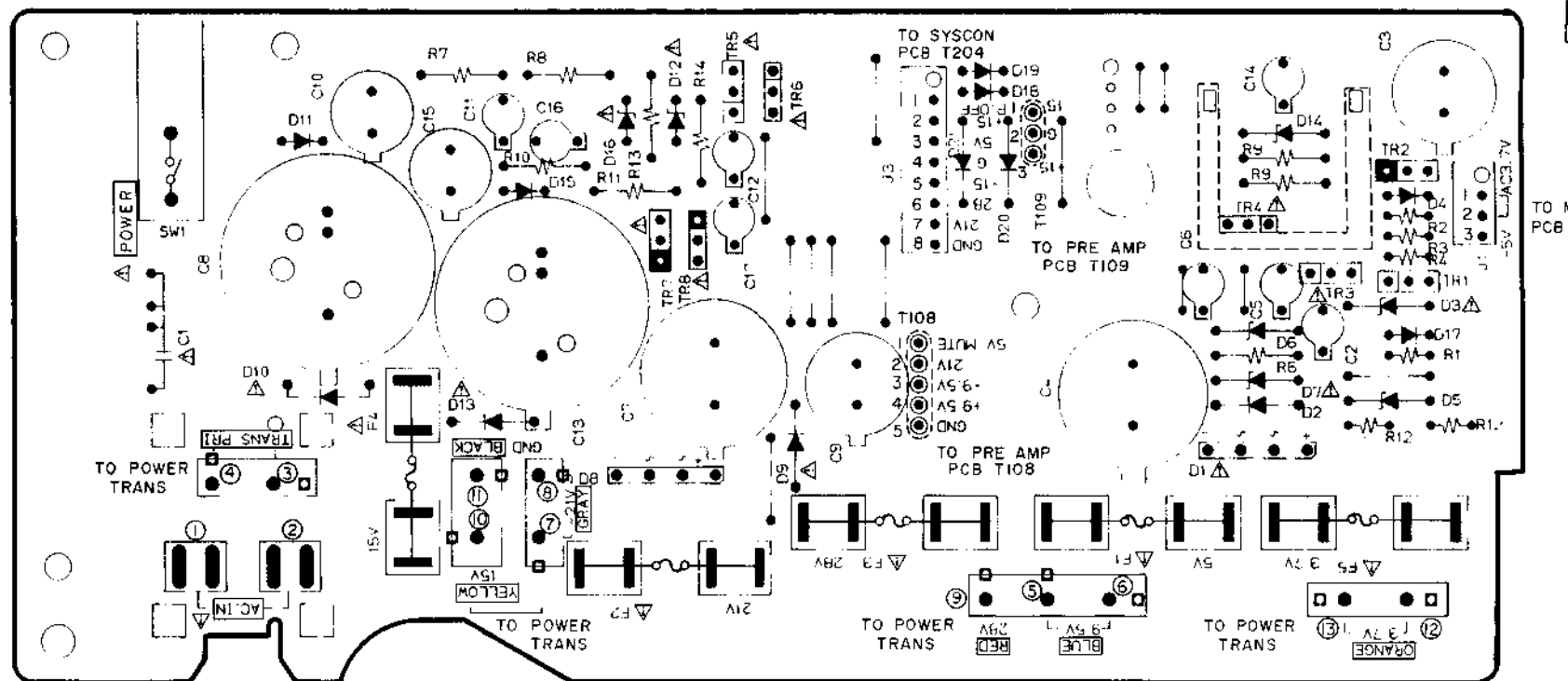
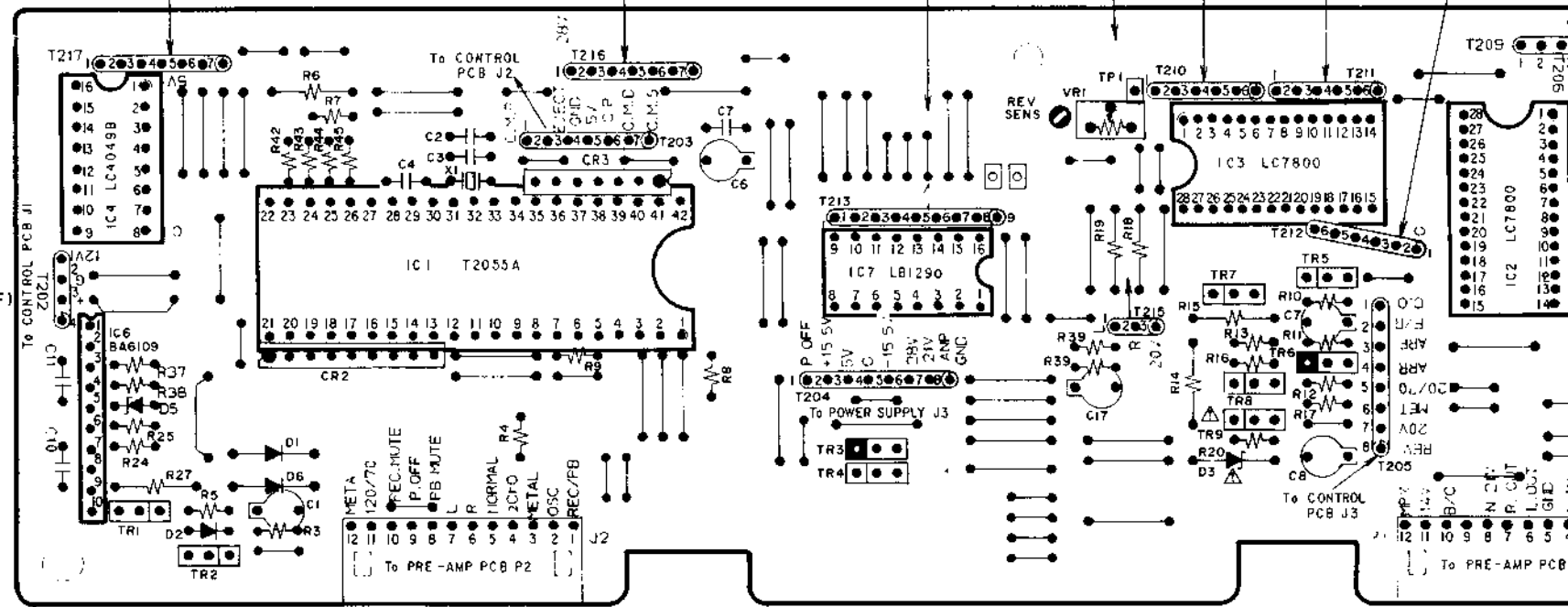

*	F1, F2	F3	F4	F5
J, U	500mA 250V	310mA 250V	630mA 250V	500mA 250V
C, A	500mA 125V	310mA 125V	630mA 125V	500mA 250V
E, B, S	T400mA	T250mA	T500mA	T400mA

= PNP TRANSISTOR  
 = NPN TRANSISTOR

TR1----2SC2603  
TR2----2SA1115  
TR3, 4---2SC2274  
TR5----2SC3383  
TR6----2SD794  
TR7----2SA1392  
TR8----2SB744

電源基板  
POWER SUPPLY PCB  
T2058A504D J, U  
505D C, A  
506D E, B, S

注意: この付された部品は、安全上重要部品です。交換の際は、指定部品以外は使用しないでください。  
 WARNING: THIS INDICATES SAFETY CRITICAL COMPONENTS. FOR CONTINUED SAFETY, REPLACE SAFETY CRITICAL COMPONENTS ONLY WITH MANUFACTURER'S RECOMMENDED PARTS.  
 AVERTISSEMENT: NE REMPLACEZ LES COMPOSANTS CRITIQUES DE SURETE POUR MAINTENIR LE DEGRE DE SECURITE DE L'APPAREIL. NE REMPLACEZ LES COMPOSANTS DON'T LE FONCTIONNEMENT EST CRITIQUE POUR LA SECURITE QUE PAR DES PIECES RECOMMANDEES PAR LE FABRICANT.

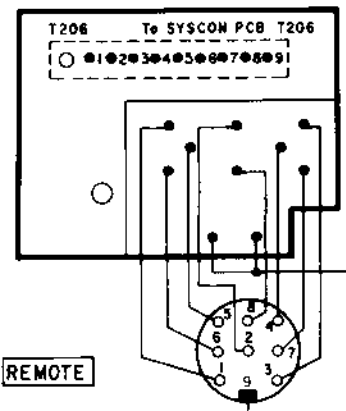
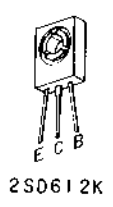
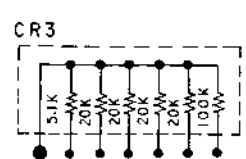
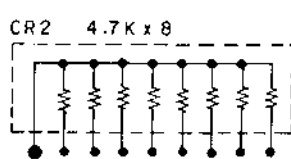
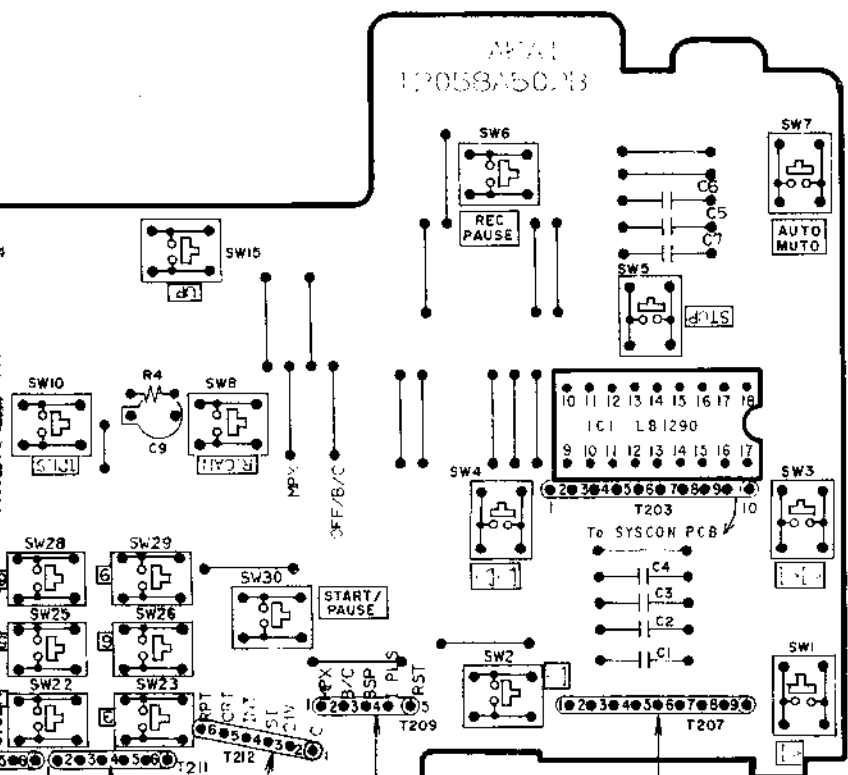

リモート基板  
 REMOTE PCB  
 T208A504E J,U  
 505E C,A  
 506E E,B,S

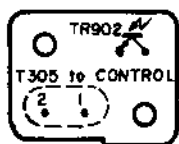
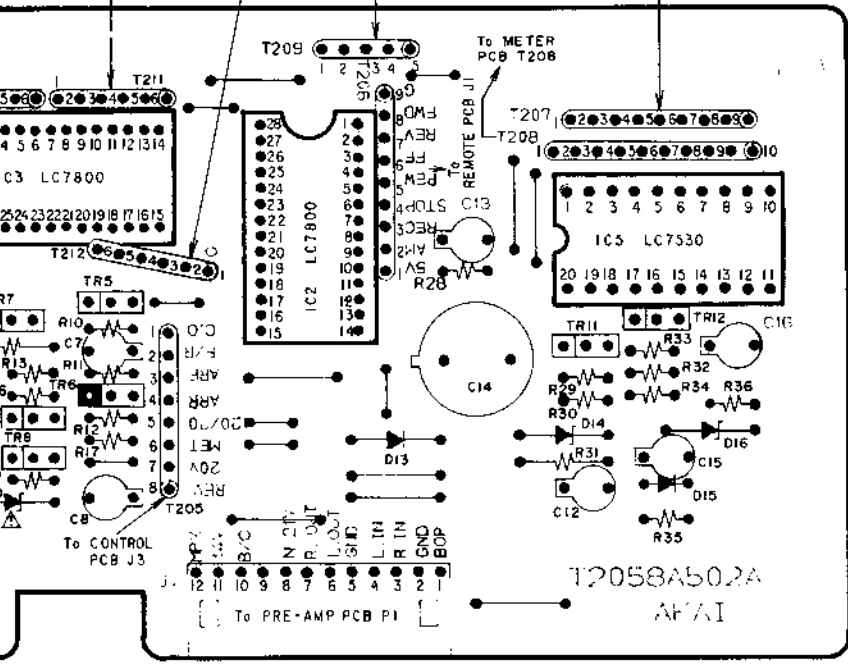

ディテクター(A)基板  
 DETECTOR(A) PCB  
 CMROID1290

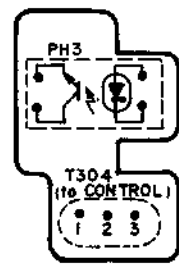

カムディレクション  
 基板  
 COM DIRECTION  
 PCB  
 CMROIC189B

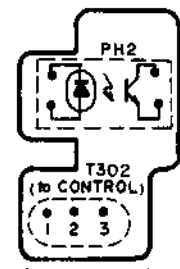

カムモーター  
 パルス基板  
 CAM MOTOR  
 PULSE PCB  
 CMROIC189C

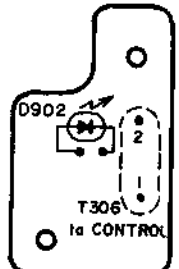

ディテクター(B)基板  
 DETECTOR(B) PCB  
 CMROID1620

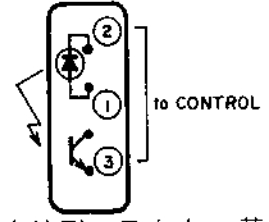

ガイドディテクター基板  
 GUIDE DETECTOR  
 PCB CMROID0220

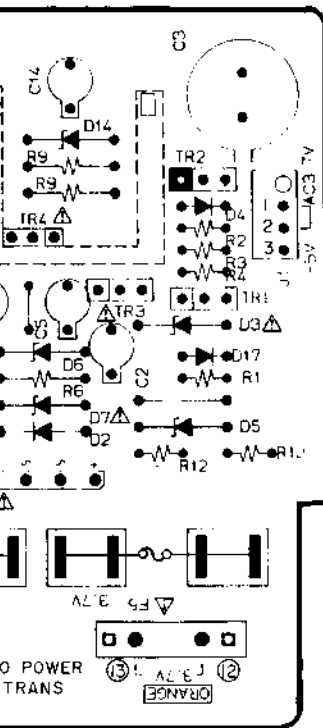

電源基板  
 POWER SUPPLY PCB  
 T2058A504D J,U  
 505D C,A  
 506D E,B,S

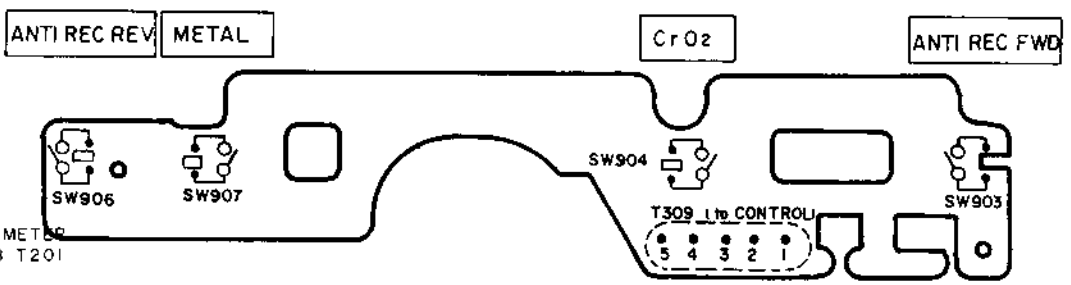

リーフスイッチ基板  
 LEAF SWITCH PCB  
 CMROIC1490

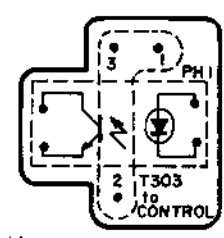

リールローテーション基板  
 REEL ROTATION  
 PCB CMROID1440

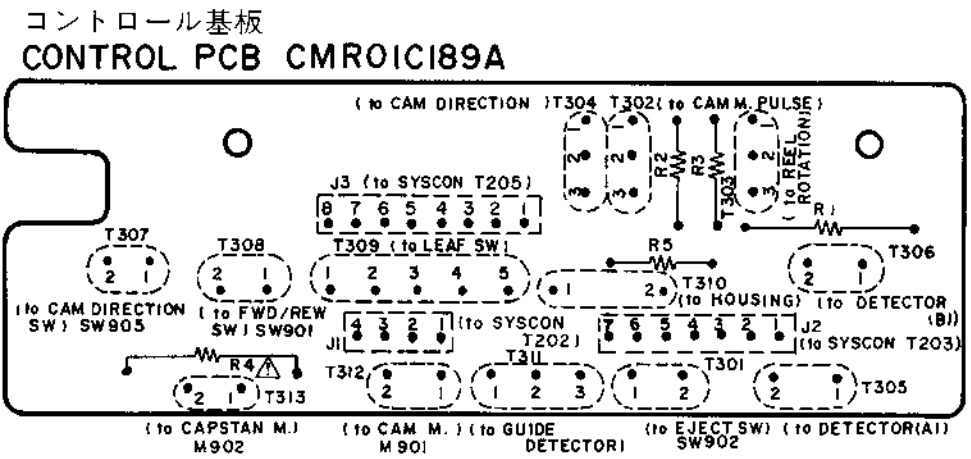

コントロール基板  
 CONTROL PCB CMROIC189A

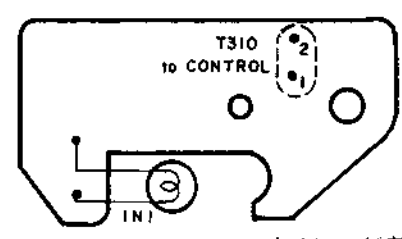

ハウジング基板  
 HOUSING PCB  
 CMROID1430



GX-R55

ジャック基板  
JACK PCB 1/3

- [J][U] :T2058A504B
- [C][A] :T2058A505B
- [E][S][B] :T2058A506B

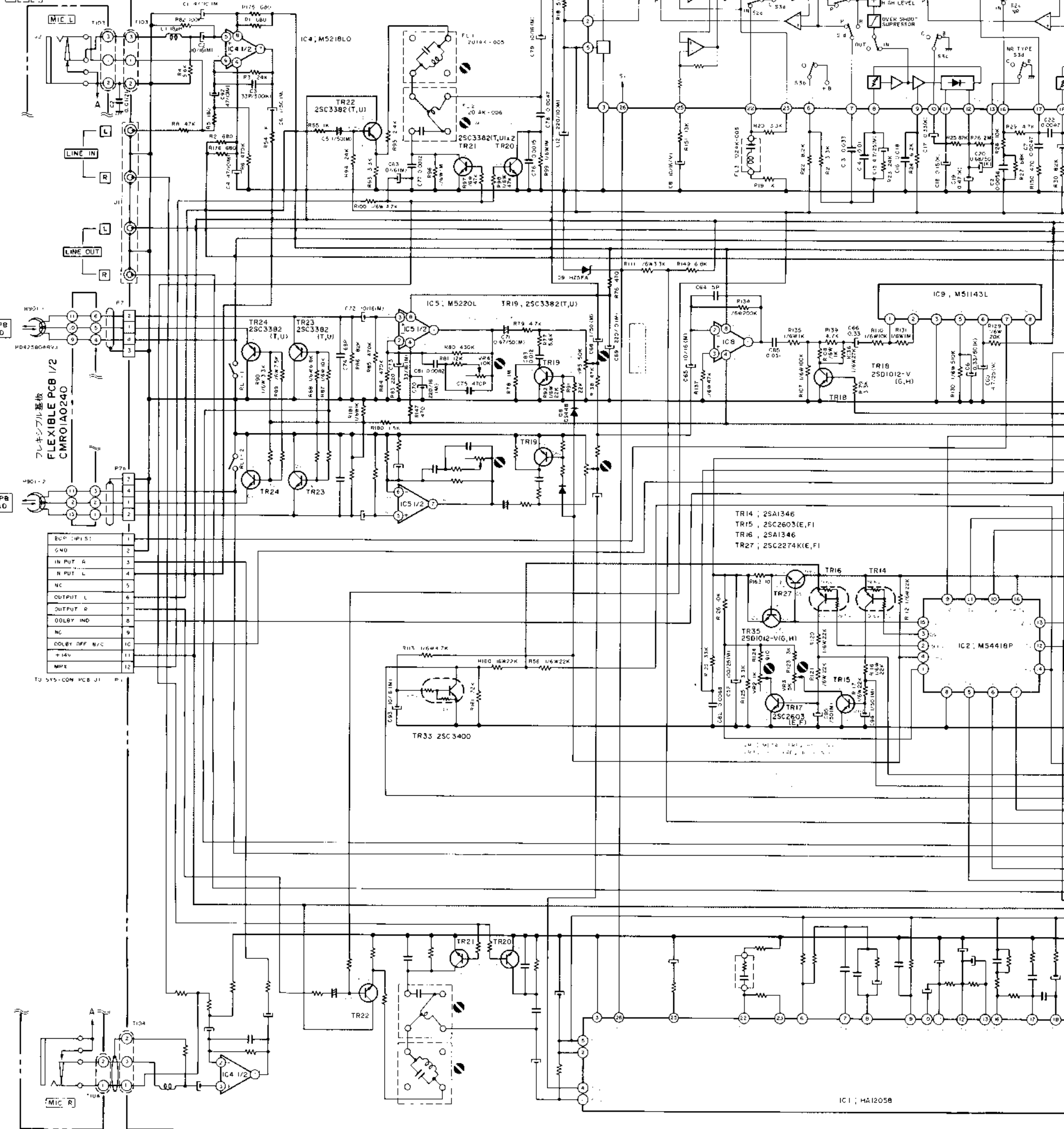

ジャック基板  
JACK PCB 1/3

WARNING INDICATES SAFETY CRITICAL COMPONENTS  
FOR CONTINUED SAFETY REPLACE SAFETY CRITICAL COMPONENTS  
WITH MANUFACTURER'S RECOMMENDED PARTS

- 25A1115
- 25C339B
- 25C3400
- 25D794
- 25A999
- 25A1246
- 25A392
- 25C2274K
- 25C2520
- 25C3582
- 25C3383
- 25A1346
- 25C2603
- 25D1012-V

プリアンプ基板  
PRE AMP PCB

- [J][U] :T2058A504A
- [C][A] :T2058A505A
- [E][S][B] :T2058A506A

NOTE  
C 400V  
100V  
100V  
100V  
100V

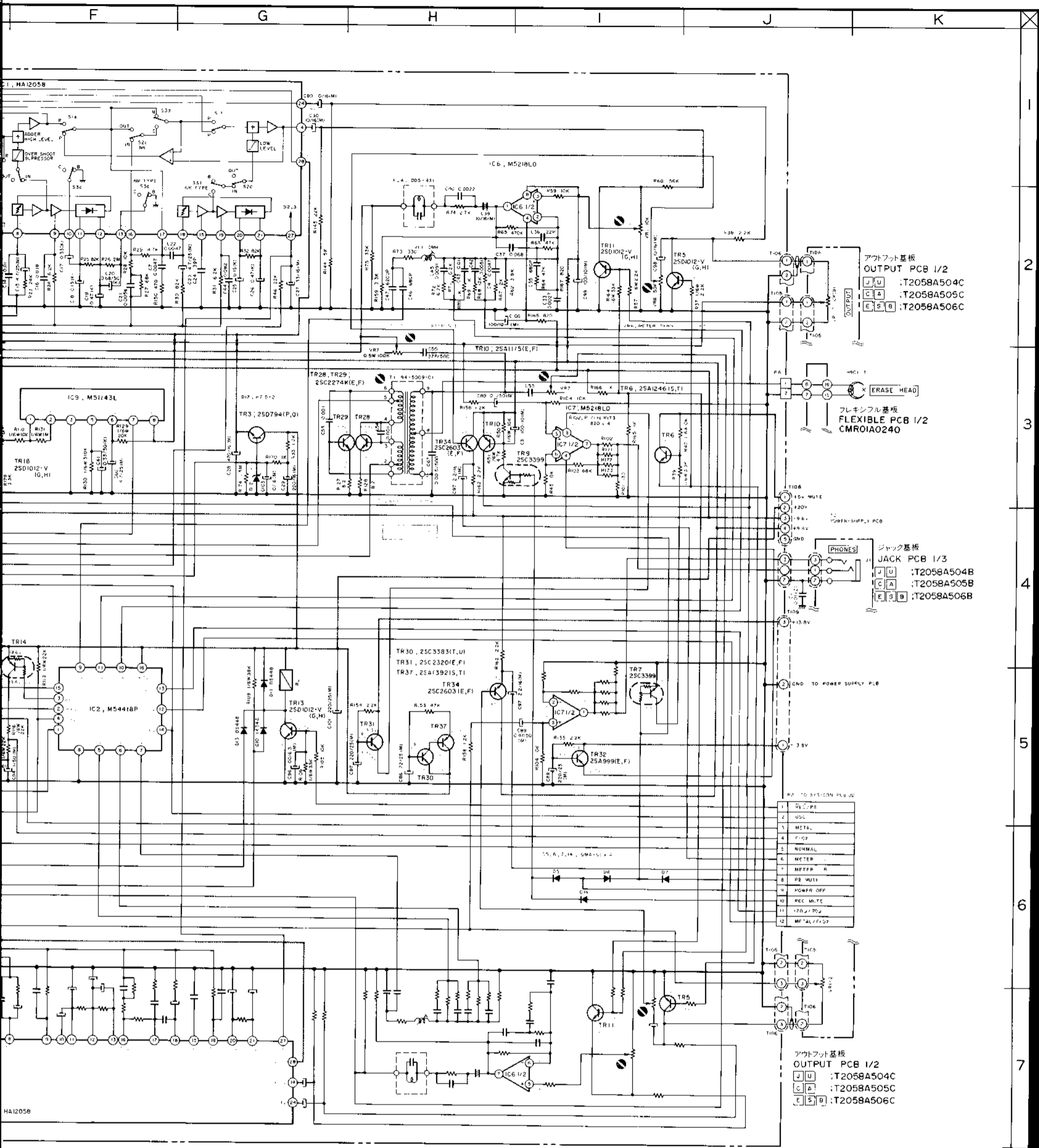

アウトプット基板  
OUTPUT PCB 1/2  
 [U] :T2058A504C  
 [C] :T2058A505C  
 [E] :T2058A506C

フレキシブル基板  
FLEXIBLE PCB 1/2  
CMR0A0240

ジャック基板  
JACK PCB 1/3  
 [U] :T2058A504B  
 [C] :T2058A505B  
 [E] :T2058A506B

PP TO SYSTEM PLEASE

1	DC
2	DC
3	METAL
4	DC
5	NORMAL
6	METER
7	METER R
8	PE MUTE
9	POWER OFF
10	REC MUTE
11	120V TO
12	METAL/DC

アウトプット基板  
OUTPUT PCB 1/2  
 [U] :T2058A504C  
 [C] :T2058A505C  
 [E] :T2058A506C

HA1205B  
 2058A504A  
 2058A505A  
 2058A506A

NOTE  
 UNLESS OTHERWISE SPECIFIED,  
 RESISTORS IN OHMS (1/4W 1%)  
 CAPACITORS IN  $\mu$ F 50WV

電源線  
再生信号線  
録音信号線  
録音線  
録音線 (左チャンネルのみ)

○ B (POWER SUPPLY) LINE  
 ○ REC SIGNAL LINE  
 ○ PB SIGNAL LINE  
 ○ SIGNAL LINE IS INDICATED LEFT CHANNEL ONLY

GX-R55  
 PRE AMPLIFIER  
 SCHEMATIC DIAGRAM  
 NO.2-2 840329A

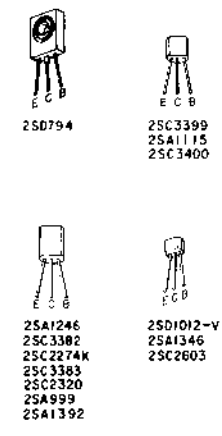
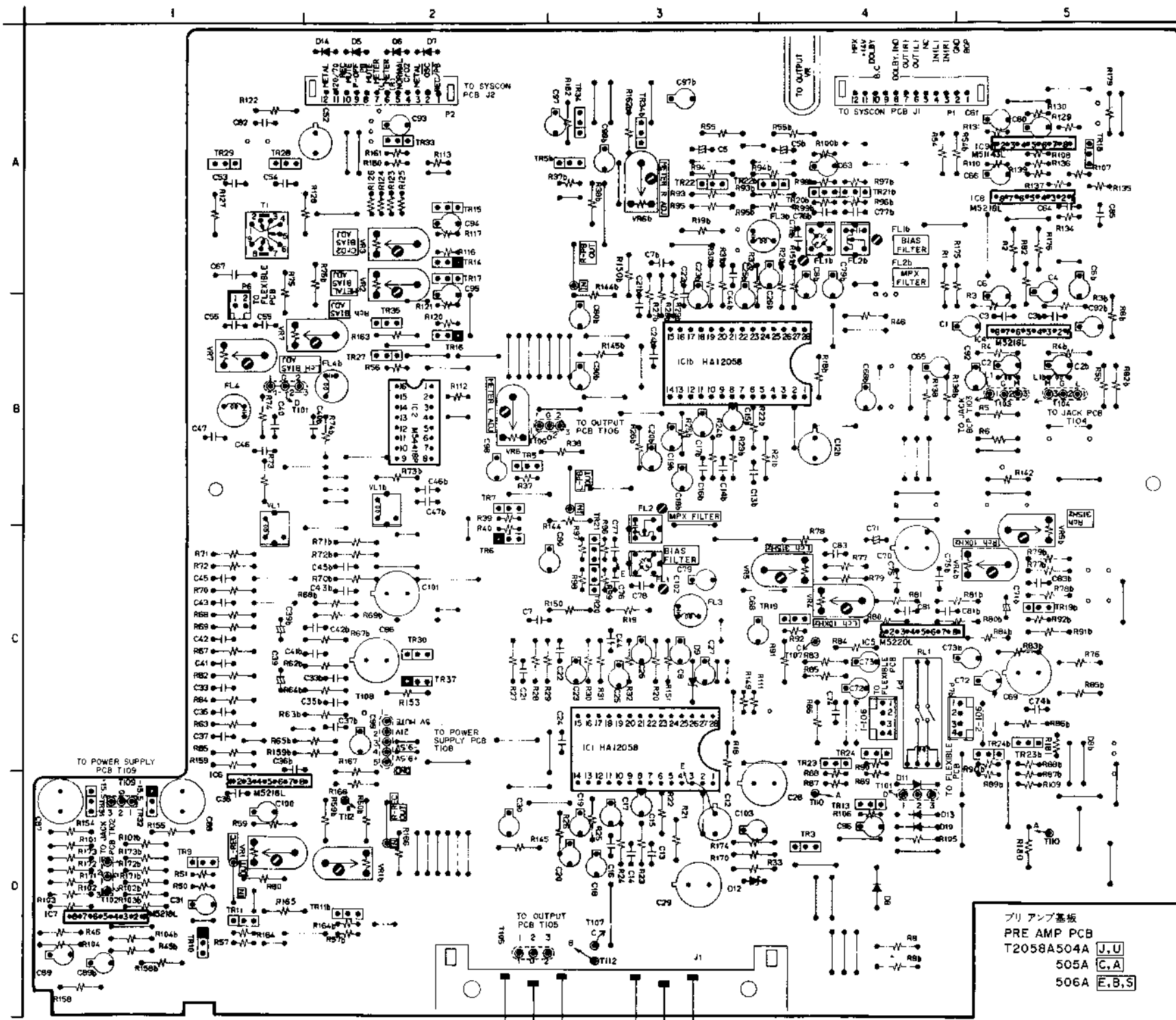

B : PNP TRANSISTOR  
 B : NPN TRANSISTOR

LOCATION OF COMPONENTS

IC'S	TR'S
IC1-----83,C3	TR3-----D4
IC2-----82	TR5-----A3,B2
IC4-----85	TR6-----C2
IC5-----C4	TR7-----B2
IC6-----D1	TR9-----D1
IC7-----D1	TR10-----D1
IC8-----A5	TR11-----D1,2
IC9-----A5	TR13-----D4
	TR14-----A2
	TR15-----A2
	TR16-----B2
	TR17-----A2
	TR18-----A5
	TR19-----C4,C5
	TR20-----A4,C3
	TR21-----A4,C3
	TR22-----A3,A4
	TR23-----C4,C5
	TR24-----C4,C5
	TR27-----B2
	TR28-----A1
	TR29-----A1
	TR30-----C2
	TR31-----D1
	TR32-----D1
	TR33-----A2
	TR34-----A3
	TR35-----B2
	TR37-----C2

TR3-----	2SD794(R,Q)
TR5,11,13,16,35-----	2SD1012-V(G,H)
TR6-----	2SA1246(S,T)
TR7,9-----	2SC3399
TR10-----	2SA1151(E,F)
TR14,16-----	2SA1346
TR15,17,34-----	2SC2603(E,F)
TR19 to 24-----	2SC3382(I,U)
TR27 to 29-----	2SC2274K(E,F)
TR30-----	2SC3383(I,U)
TR31-----	2SC2320(E,F)
TR32-----	2SA999(E,F)
TR33-----	2SC3400
TR37-----	2SA1392(S,T)

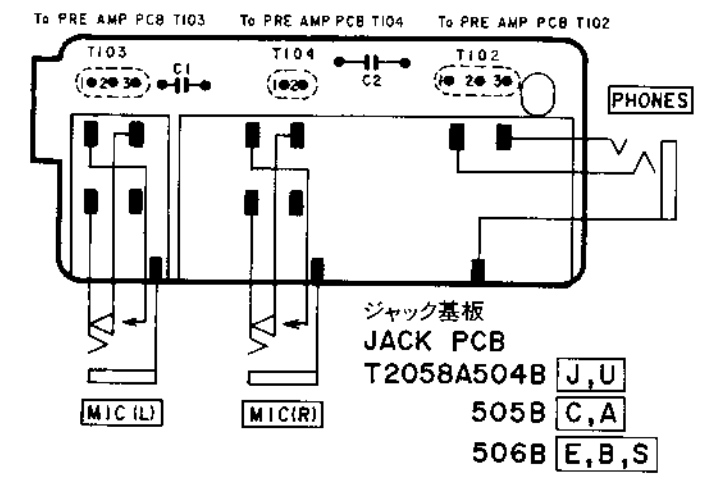

プリ アンプ基板  
 PRE AMP PCB  
 T2058A504A J,U  
 505A C,A  
 506A E,B,S

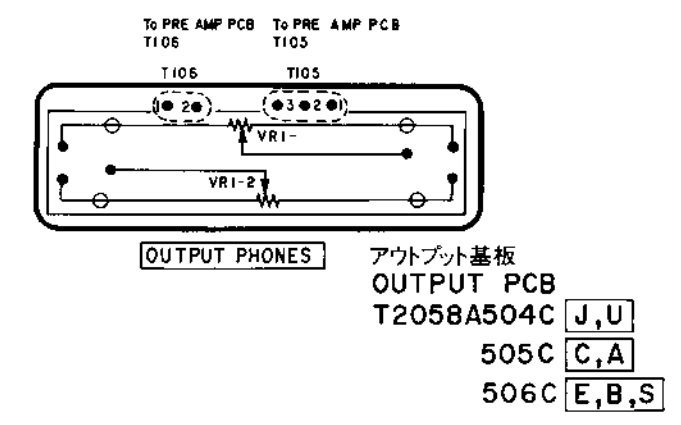

FLEXIBLE PCB CMR01A0240  
 フレキシブル基板

注意: 1. の付された部品は、安全上重要部品です。交換の際は、指定部品以外は使用しないこと。  
 WARNING: 1. INDICATES SAFETY CRITICAL COMPONENTS FOR CONTINUED SAFETY, REPLACE SAFETY CRITICAL COMPONENTS ONLY WITH MANUFACTURER'S RECOMMENDED PARTS.  
 AVERTISSEMENT: 1. IL INDIQUE LES COMPOSANTS CRITIQUES DE SURETE POUR MAINTENIR LE DEGRE DE SECURITE DE L'APPAREIL. NE REMPLACER LES COMPOSANTS DONT LE FONCTIONNEMENT EST CRITIQUE POUR LA SECURITE QUE PAR DES PIECES RECOMMANDEES PAR LE FABRICANT.

### DOLBY C "ON" REC MODE (ドルビーC録音)

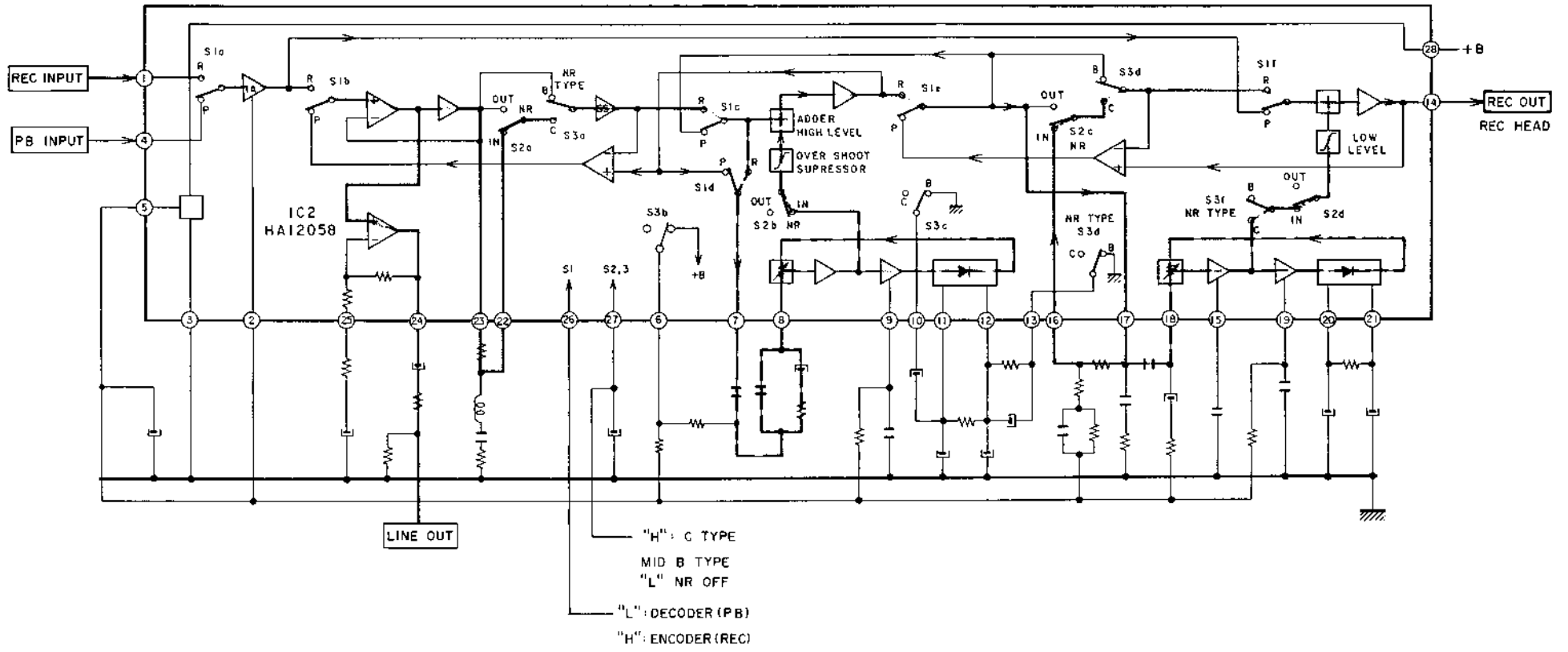

### DOLBY C P.B MODE (ドルビーC再生)

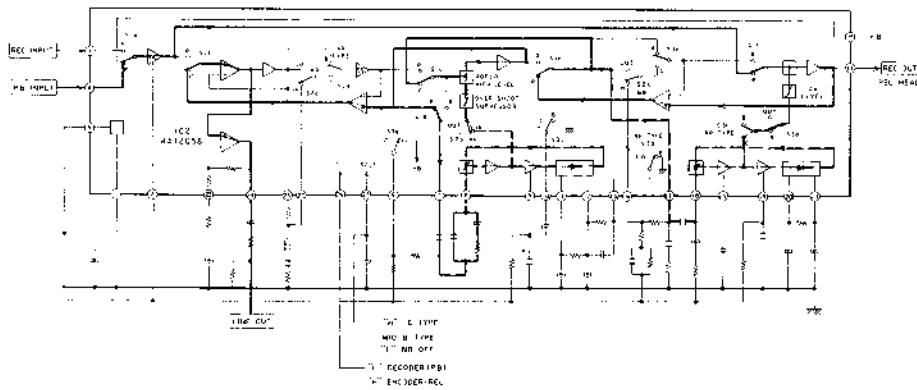

### DOLBY B REC MODE (ドルビーB録音)

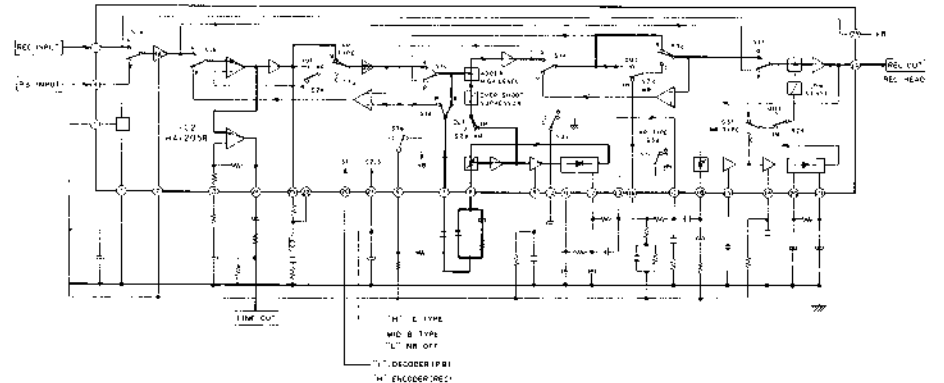

### DOLBY B P.B MODE (ドルビーB再生)

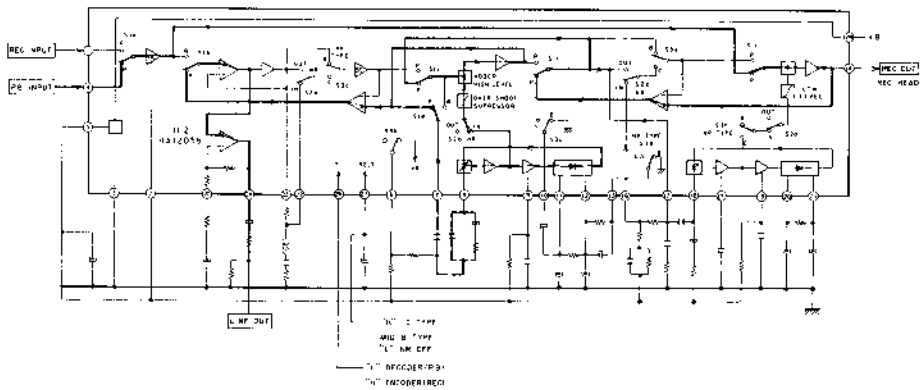

### DOLBY "OFF" REC MODE (ドルビーOFF録音)

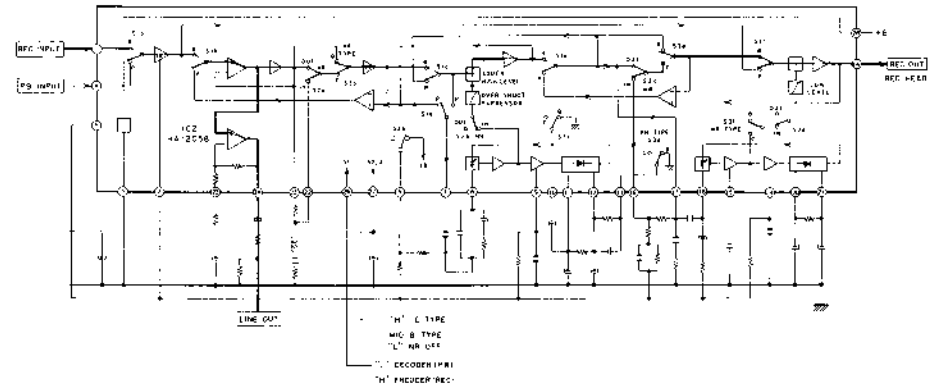

### DOLBY "OFF" P.B MODE (ドルビーOFF再生)

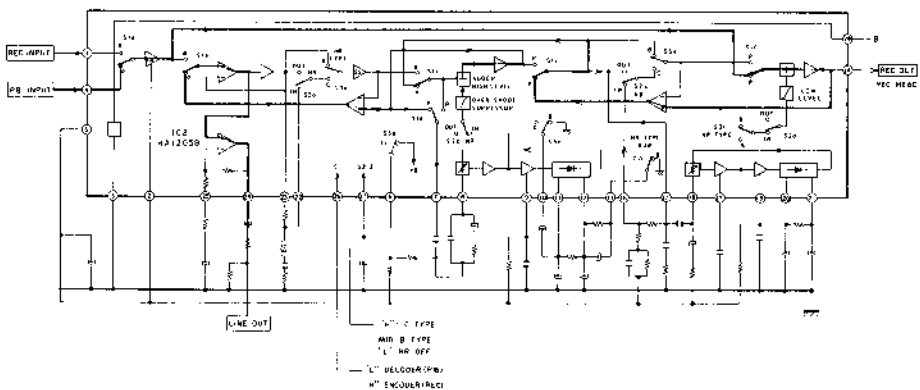

DOLBY IC (HA12038)  
(HA12058)  
SIGNAL LINE