

AKAI SERVICE MANUAL

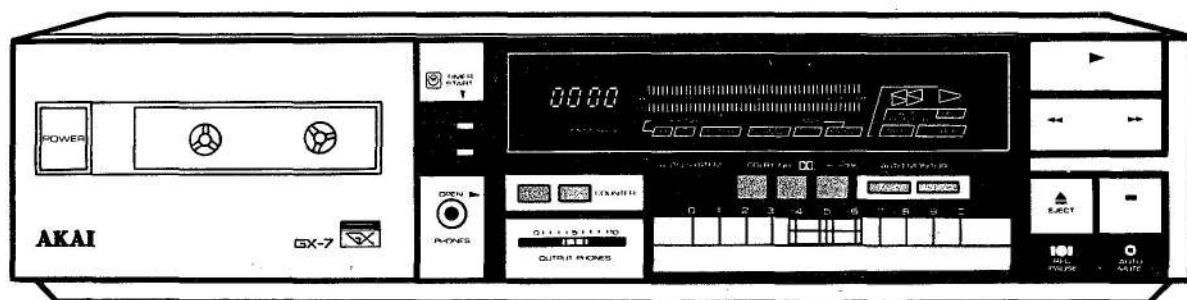

STEREO CASSETTE DECK

MODEL **GX-7**

ABBREVIATIONS FOR SERVICE MANUAL MODEL GX-7

ABBREVIATION	EXPLANATION
ASN	Anti Saturation Network
DET	DETECTOR
EQ	EQUALIZER
FF	Fast Forward
FG	Frequency Generator
FL	Fluorescent (Display)
GND	GrouND
H	High
IPLS	Instant Programme Location System
L	Low
L	Left
MICOM	Micro COMputer
M	Motor
OSC	OSCillator
PB	PlayBack
PLG	PLunGer
R	Right
REC	RECOrd
REMOCON	REMOte CONtrol
ROM	Read Only Memory
RWD	ReWinD
SDN	Spectral De-skewing Network
SSN	Spectral Skewing Network
SW	SWitch
SYSCON	SYStem CONtrol
VR	Variable Resistor
V. REG	Voltage REGulator
XTAL	crysTAL

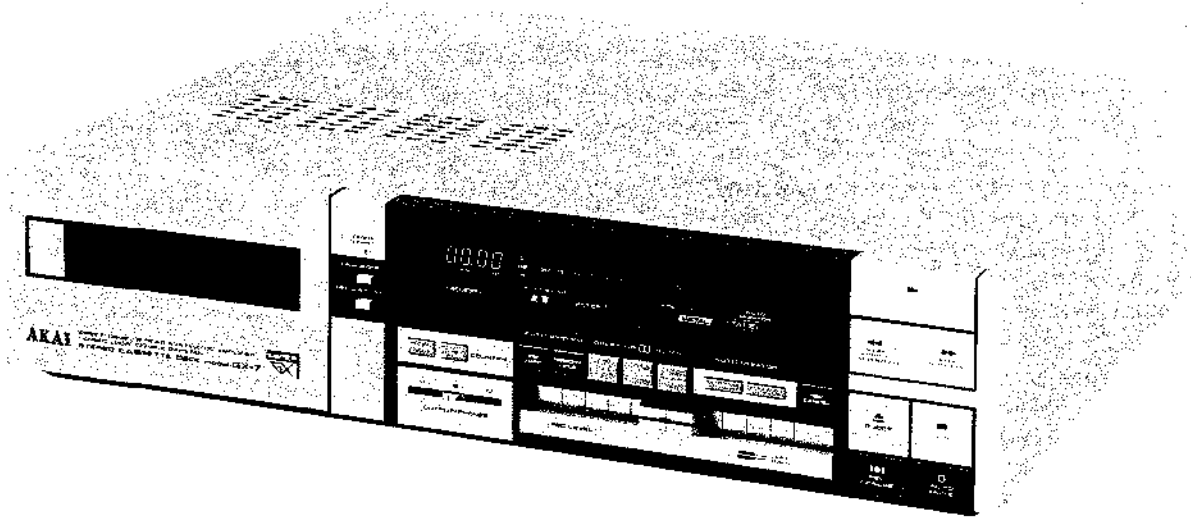

STEREO CASSETTE DECK

MODEL GX-7

THIS MANUAL IS APPLICABLE TO BOTH SILVER AND PEARL SHADOW PANEL MODELS

SECTION 1	SERVICE MANUAL	3
SECTION 2	PARTS LIST	29
SECTION 3	SCHEMATIC DIAGRAM	40

SAFETY INSTRUCTIONS

SAFETY CHECK AFTER SERVICING

Confirm the specified insulation resistance between power cord plug prongs and externally exposed parts of the set is greater than 10 Mohms, but for equipment with external antenna terminals (tuner, receiver, etc.) and is intended for **C** or **A**, specified insulation resistance should be more than 2.2 Mohms (ground terminals, microphone jacks, headphone jacks, line-in-out jacks etc.)

PRECAUTIONS DURING SERVICING

1. Parts identified by the **A** symbol parts are critical for safety.
Replace only with parts number specified.
2. In addition to safety, other parts and assemblies are specified for conformance with such regulations as those applying to spurious radiation. These must also be replaced only with specified replacements.
Examples: RF converters, tuner units, antenna selector switches, RF cables, noise blocking capacitors, noise blocking filters, etc.
3. Use specified internal wiring. Note especially:
 - 1) Wires covered with PVC tubing
 - 2) Double insulated wires
 - 3) High voltage leads
4. Use specified insulating materials for hazardous live parts. Note especially:
 - 1) Insulation Tape
 - 2) PVC tubing
 - 3) Spacers (Insulating Barriers)
 - 4) Insulation sheets for transistors
 - 5) Plastic screws for fixing microswitch (especially in turntable)
5. When replacing AC primary side components (transformers, power cords, noise blocking capacitors, etc.), wrap ends of wires securely about the terminals before soldering.

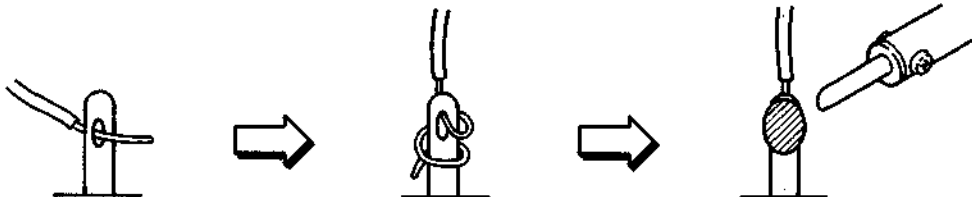

6. Observe that wires do not contact heat producing parts (heatsinks, oxide metal film resistors, fusible resistors, etc.).
7. Check that replaced wires do not contact sharp edged or pointed parts.
8. Also check areas surrounding repaired locations.
9. Use care that foreign objects (screws, solder droplets, etc.) do not remain inside the set.

SECTION 1

SERVICE MANUAL

TABLE OF CONTENTS

I.	SPECIFICATIONS.....	4
II.	DISMANTLING OF UNIT.....	5
III.	CONTROLS.....	6
IV.	PRINCIPAL PARTS LOCATION.....	7
V.	VOLTAGE AND CYCLE CONVERSION.....	8
	1. VOLTAGE CONVERSION.....	8
	2. CYCLE CONVERSION.....	8
VI.	CIRCUIT OPERATION DESCRIPTION.....	9
	1. GX-7 SYSCON BLOCK DIAGRAM.....	9
	2. PRE AMP BLOCK DIAGRAM.....	9
	3. POWER SUPPLY TO SYSTEMS.....	10
	4. CAM MOTOR DRIVE CIRCUIT.....	10
	5. REEL MOTOR DRIVE CIRCUIT.....	11
	6. AUTO MONITOR SYSTEM.....	12
	7. POWER ON/OFF DETECTOR.....	13
	8. MUTE CIRCUIT.....	14
	9. MUTE SIGNAL TO SYSTEMS.....	14
	10. DOLBY CIRCUIT.....	15
VII.	MECHANICAL ADJUSTMENT.....	16
	1. PINCH ROLLER PRESSURE MEASUREMENT.....	16
	2. TAPE SPEED ADJUSTMENT.....	16
	3. HOW TO INSTAL VARIABLE RESISTOR (VR901) AND CAM WHEEL.....	17
	4. POTENTIOMETER PRESET VOLTAGE ADJUSTMENT.....	18
VIII.	HEAD ADJUSTMENT.....	19
	1. REC/PB HEAD PROJECTION ADJUSTMENT.....	19
	2. TAPE GUIDE HEIGHT ADJUSTMENT.....	19
	3. REC/PB HEAD HEIGHT ADJUSTMENT.....	19
	4. REC/PB HEAD AZIMUTH ALIGNMENT ADJUSTMENT.....	19
IX.	AMPLIFIER ADJUSTMENT.....	20
X.	DC RESISTANCE OF HEADS.....	21
XI.	CLASSIFICATION OF VARIOUS P.C BOARDS.....	22
	1. P.C BOARD TITLES AND IDENTIFICATION NUMBERS.....	22
	2. COMPOSITION OF VARIOUS P.C BOARDS.....	23

For basic adjustments, measuring methods, and operating principles, refer to GENERAL TECHNICAL MANUAL.

I. SPECIFICATIONS

TRACK SYSTEM	4 Track 2 Channel Stereo System
TAPE	Philips Type Cassette
TAPE SPEED	4.76cm/s \pm 1.0% (1-7/8ips \pm 1.0%)
HEADS	Super GX Head for Recording x 1 Super GX Head for Playback x 1 Erase Head x 1
MOTORS	FG Servo D.C. Motor for Direct Capstan Drive x 1 D.C. Motor for Reel Drive x 1
WOW & FLUTTER	0.028% WRMS 0.08% WTD (DIN) \pm 0.055% W.Peak (EIAJ)
TAPE WINDING TIME	90 Sec. Using a C-60 Cassette Tape
FREQUENCY RESPONSE (EIAJ)	Normal: 20 to 17,000Hz \pm 3dB CrO ₂ : 20 to 18,000Hz \pm 3dB Metal: 20 to 21,000Hz \pm 3dB
SIGNAL-TO-NOISE RATIO (METAL TAPE)	60dB: (WTD, 1kHz 3RD Harmonic Distortion) 56dB: (EIAJ) Dolby B on: Improves up to 5dB at 1kHz, 10dB at 10kHz Dolby C on: Improves up to 15dB at 500Hz, 20dB at 1kHz to 10kHz
HARMONIC DISTORTION	1kHz, 3RD Harmonic Distortion Metal: 0.7% (EIAJ)
INPUT	Line: 70mV (47kohms)
OUTPUT	Line: 410mV (Less than 2kohms) Headphone: 1.3mW (8ohms)
POWER REQUIREMENTS	100V, 50/60Hz for Japan 120V, 60Hz for USA and Canada 220V, 50Hz for Europe except UK 240V, 50Hz for UK and Australia 110V/120V/220V/250V, 50Hz/60Hz Switchable for other countries.
POWER CONSUMPTION	U,C,A Models: 24W J model: 22W
DIMENSIONS	440 (W) x 102 (H) x 337 (D) mm (17.3 x 4.0 x 13.3")
WEIGHT	5.8kg (12.8 lbs)

- * For improvement purposes, specifications and design are subject to change without notice.
- * "DOLBY" and the double D symbol are trademark of Dolby Laboratories.
(Manufactured under license from Dolby Laboratories)
- * There are no values indicated in JIS standard on items such as frequency response and harmonic distortion, but please refer to the values indicated above since they have very slight deference between them.

II. DISMANTLING OF UNIT

In case of trouble, etc. necessitating dismantling, please dismantle in the order shown in the photographs. Reassemble in reverse order.

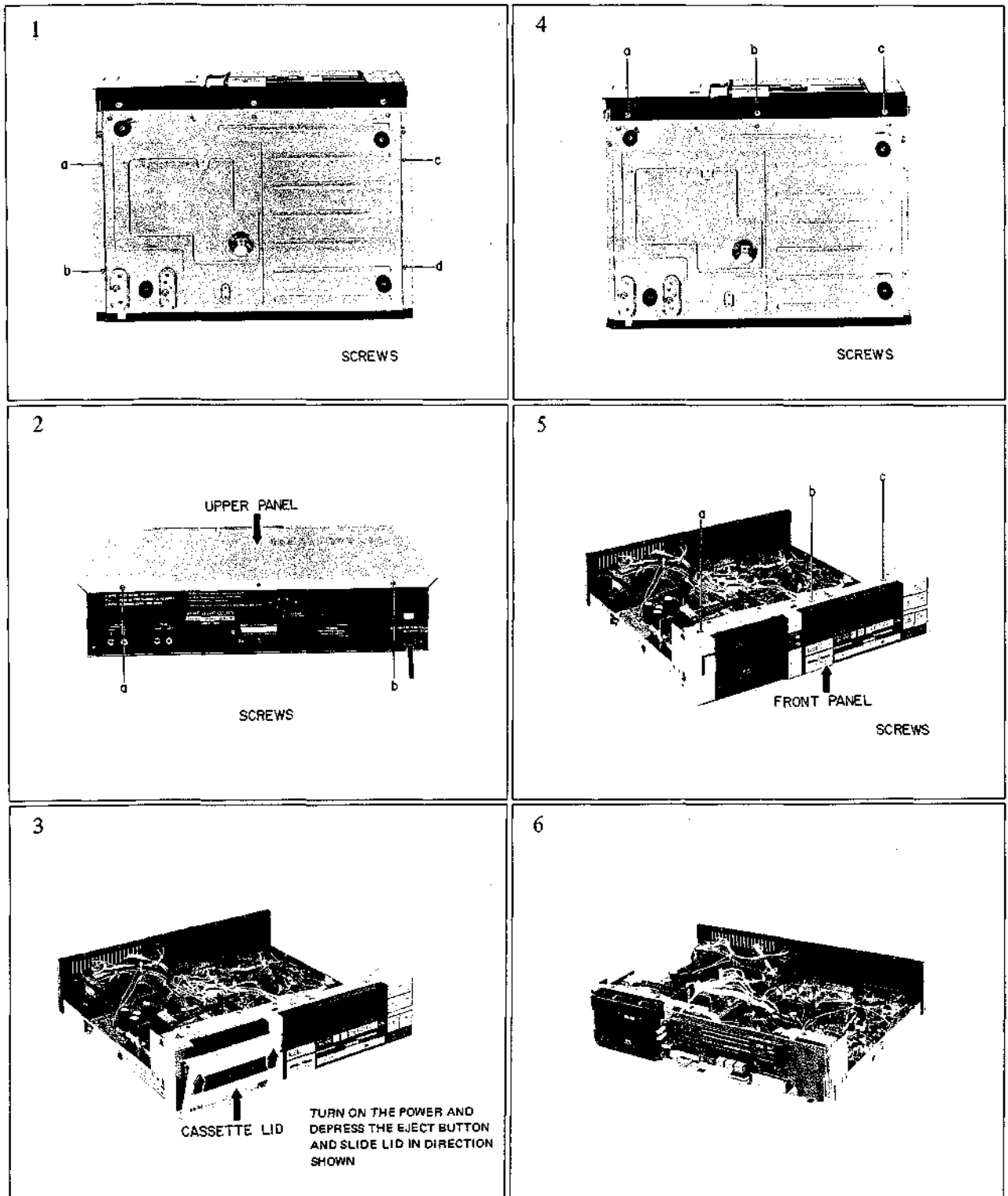

III. CONTROLS

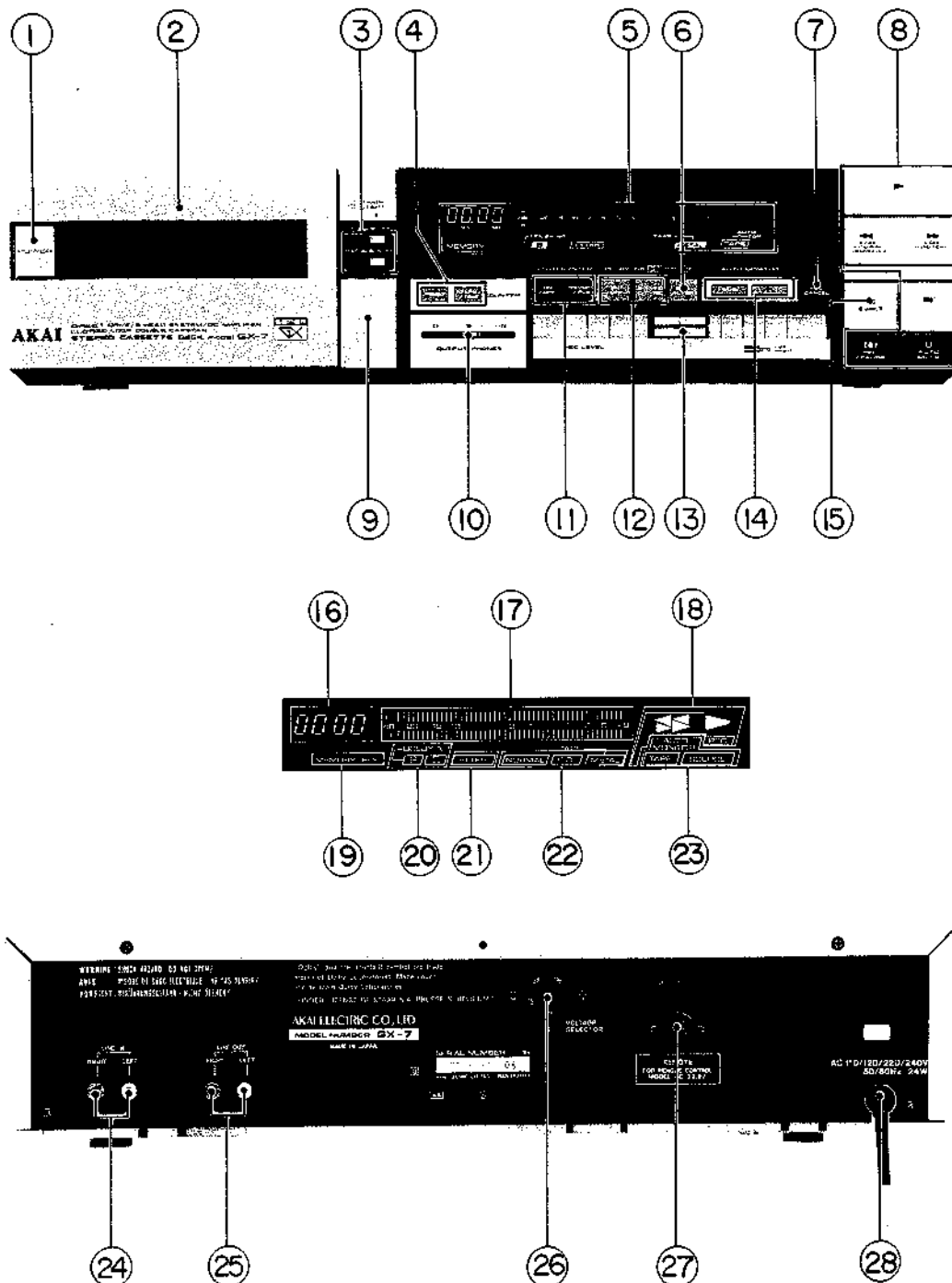

Fig. 3-1

- | | |
|---|--|
| 1. POWER SWITCH | 15. EJECT BUTTON |
| 2. CASSETTE LID | 16. DIGITAL TAPE/TIME COUNTER |
| 3. TIMER START SELECTOR (ON/OFF & REC/PLAY) | 17. BAR LEVEL METER |
| 4. COUNTER SELECTOR (RESET & TAPE/TIME) | 18. OPERATION INDICATOR
(PLAY, PLAY PAUSE, REC PAUSE, REC PLAY, AUTO
MUTE, FF, REW, IPLS, INTRO SCAN, AUTO/MEMORY
PLAY) |
| 5. FL DISPLAY | 19. AUTO SYSTEM INDICATOR (MEMORY/IPLS) |
| 6. MPX FILTER SWITCH | 20. DOLBY NR INDICATOR (B/C) |
| 7. REC CANCEL BUTTON | 21. FILTER (MPX) INDICATOR |
| 8. OPERATION BUTTONS
PLAY (▶), STOP (■), FF (▶▶)/RWD (◀◀) REC/
PAUSE, AUTO MUTE | 22. TAPE INDICATOR (NORMAL/CrO ₂ /METAL) |
| 9. PHONES (HEADPHONE JACK) | 23. MONITOR INDICATOR (TAPE/SOURCE) |
| 10. OUTPUT/PHONES (OUTPUT/HEADPHONE LEVEL
CONTROL) | 24. LINE IN JACKS |
| 11. AUTO SYSTEM SELECTOR (ON/OFF & MEMORY/
IPLS) | 25. LINE OUT JACKS |
| 12. DOLBY NR SELECTOR (ON/OFF & B TYPE/C TYPE) | 26. VOLTAGE SELECTOR |
| 13. REC LEVEL (RECORDING LEVEL CONTROL) | 27. REMOTE CONTROL JACK |
| 14. AUTO MONITOR (MONITOR SELECTOR BUTTON-
TAPE/SOURCE) | 28. POWER CORD |

IV. PRINCIPAL PARTS LOCATION

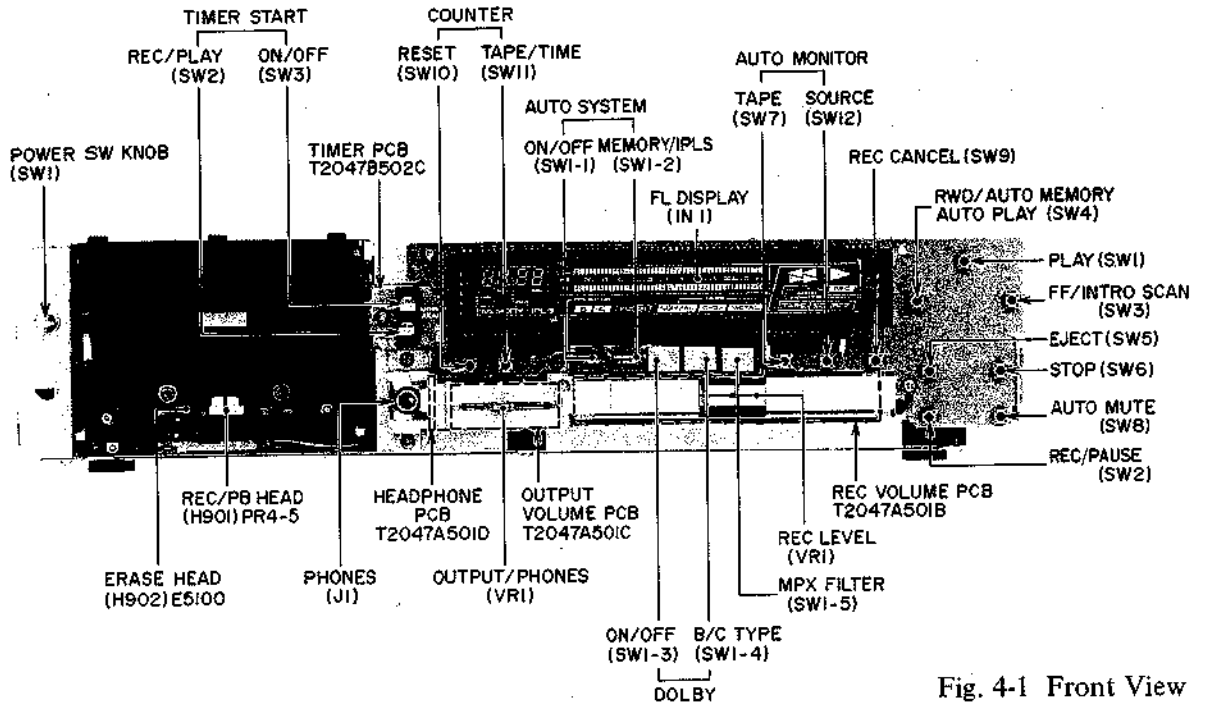

Fig. 4-1 Front View

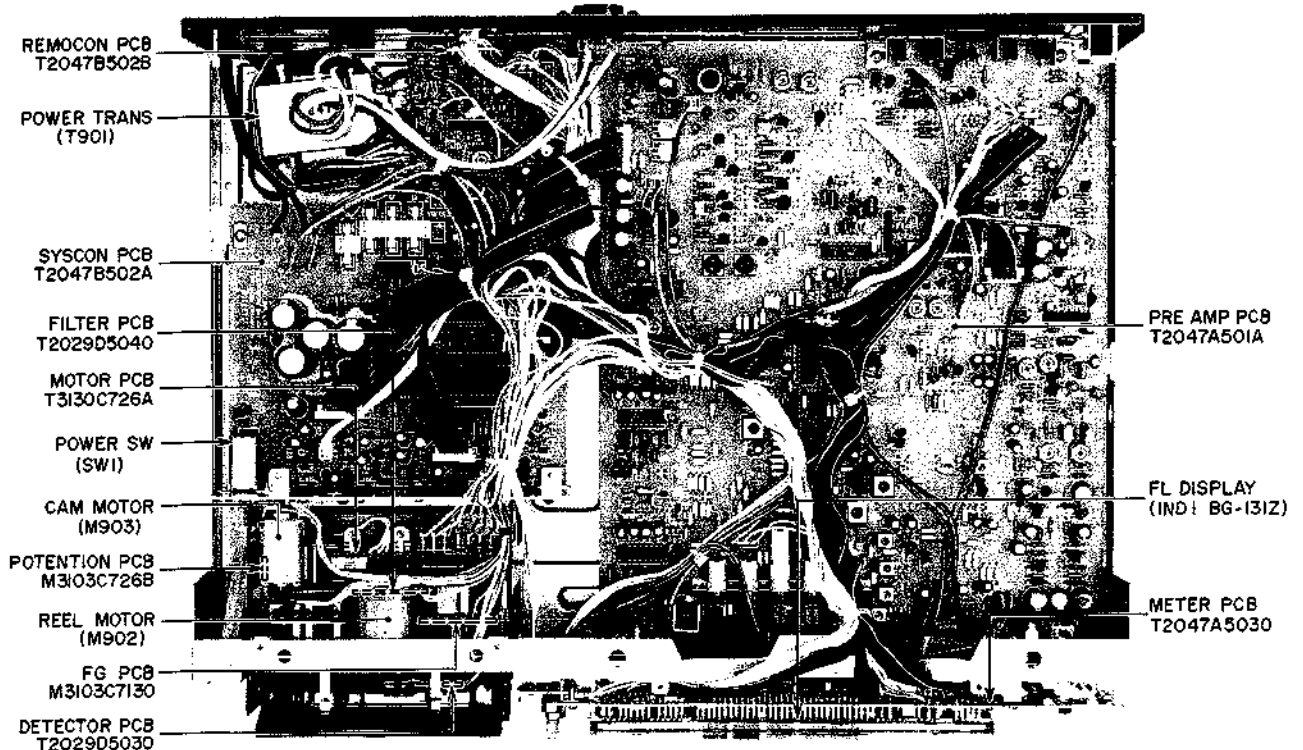

Fig. 4-2 Top View

V. VOLTAGE AND CYCLE CONVERSION

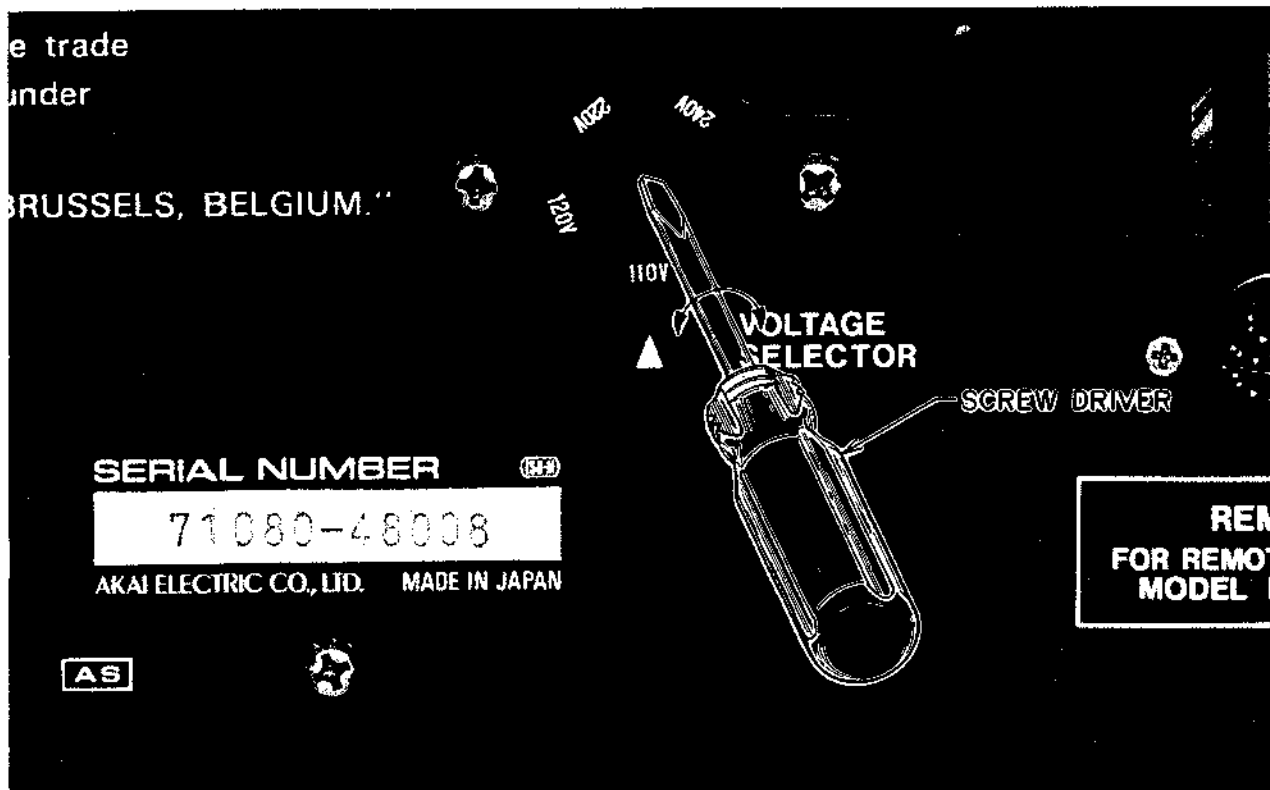

Fig. 5-1

5-1. VOLTAGE CONVERSION (Refer to Fig. 5-1)

Models for Japan, Canada, USA, Europe, UK and Australia are not equipped with this facility.

Each machine is preset at the factory according to destination, but some machines can be set to 110V, 120V, 220V or 240V as required.

If VOLTAGE CHANGE is necessary, this can be accomplished as follows:

- 1) Disconnect power cord.
- 2) Turn the VOLTAGE SELECTOR located on the rear panel with a screwdriver until the correct voltage is indicated.

5-2. CYCLE CONVERSION

With DC Motor, Cycle Conversion is not necessary.

VI. CIRCUIT OPERATION DESCRIPTION

6-1. GX-7 SYSCON BLOCK DIAGRAM (Refer to Fig. 6-1)

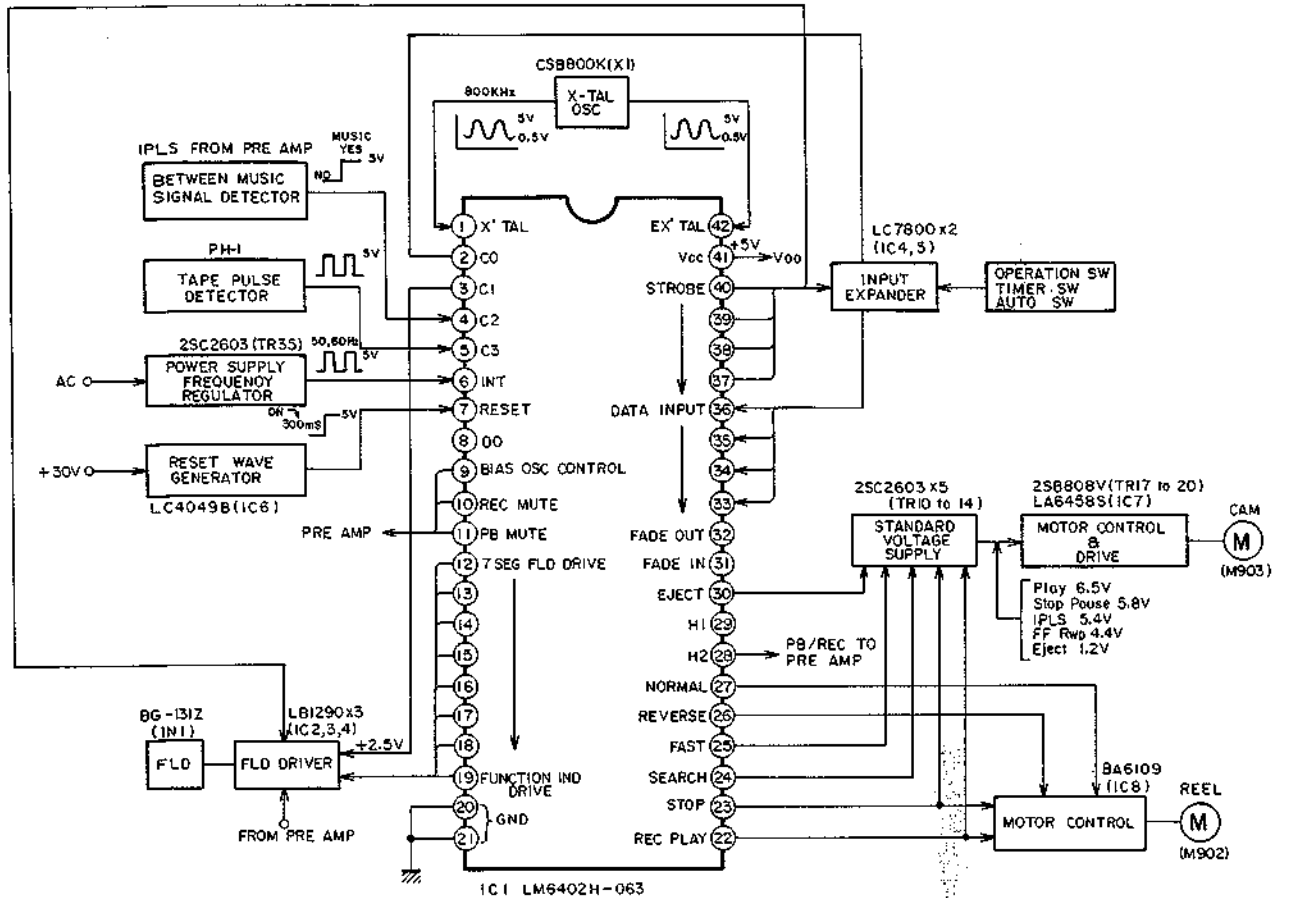

Fig. 6-1

6-2. PRE AMP BLOCK DIAGRAM (Refer to Fig. 6-2)

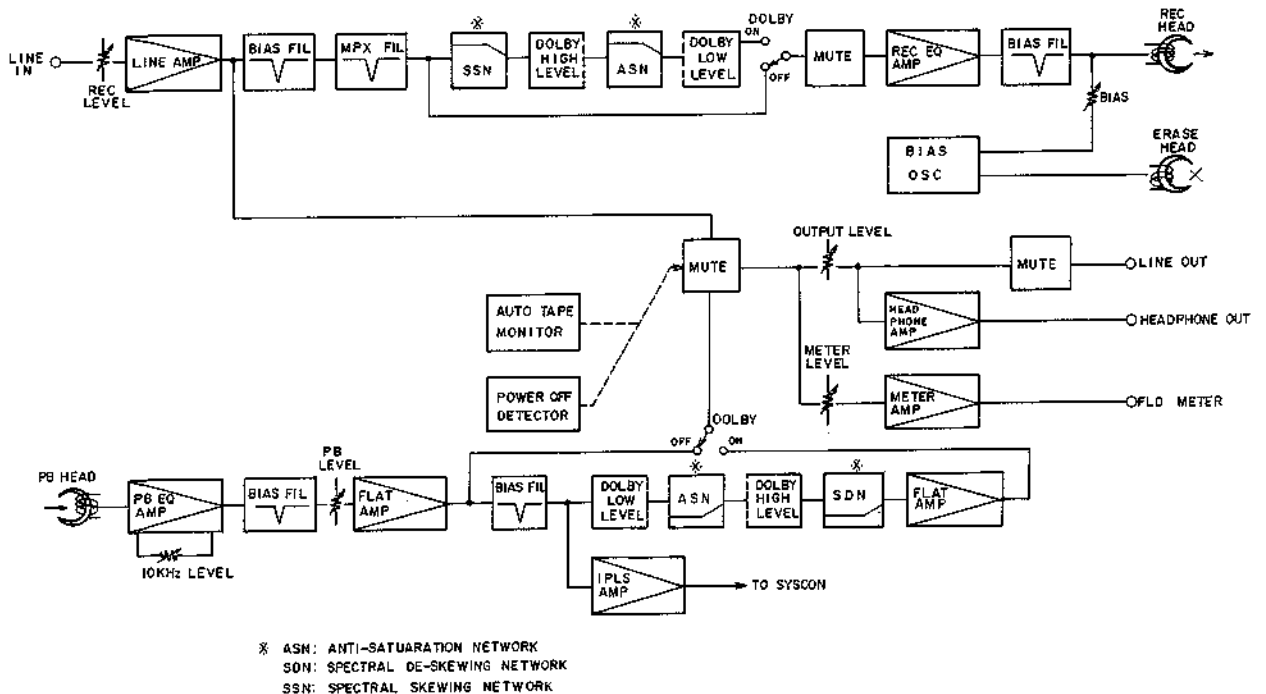

Fig. 6-2

6-3. POWER SUPPLY TO SYSTEMS (Refer to Fig. 6-3)

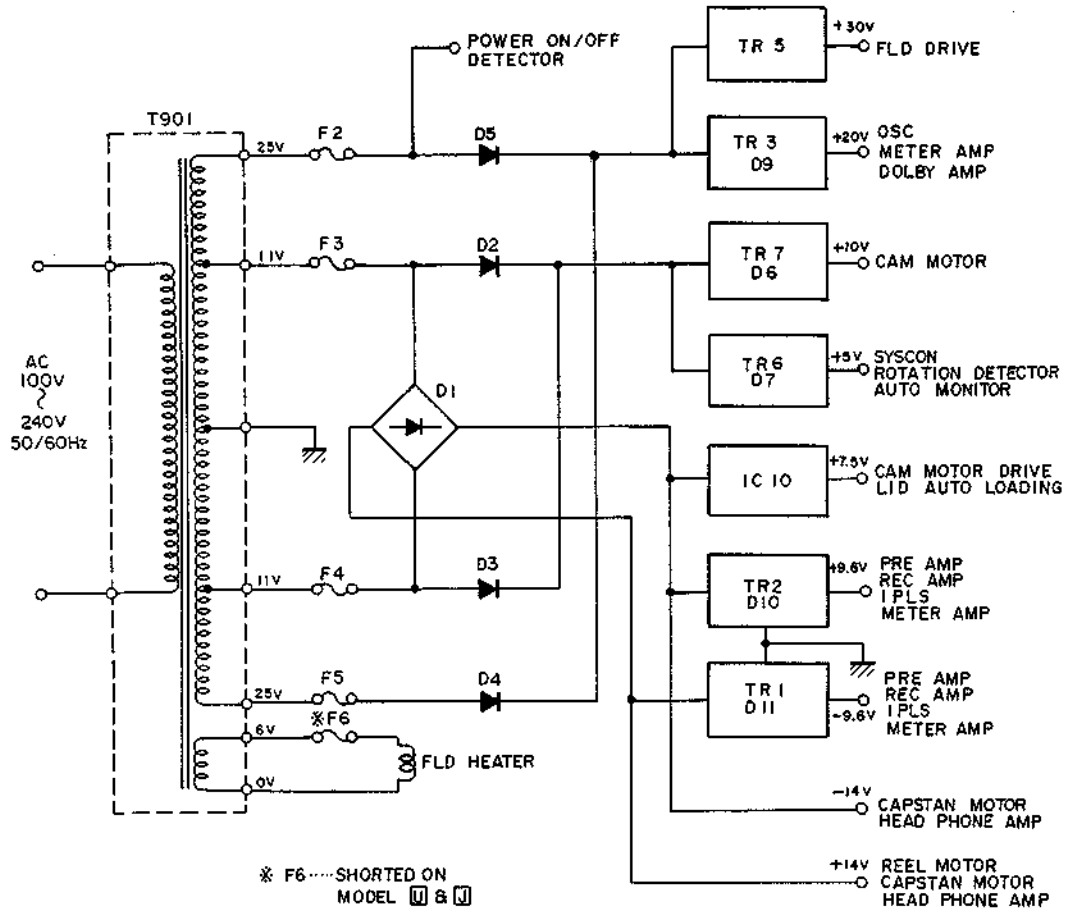

Fig. 6-3

6-4. CAM MOTOR DRIVE CIRCUIT (Refer to Fig. 6-4)

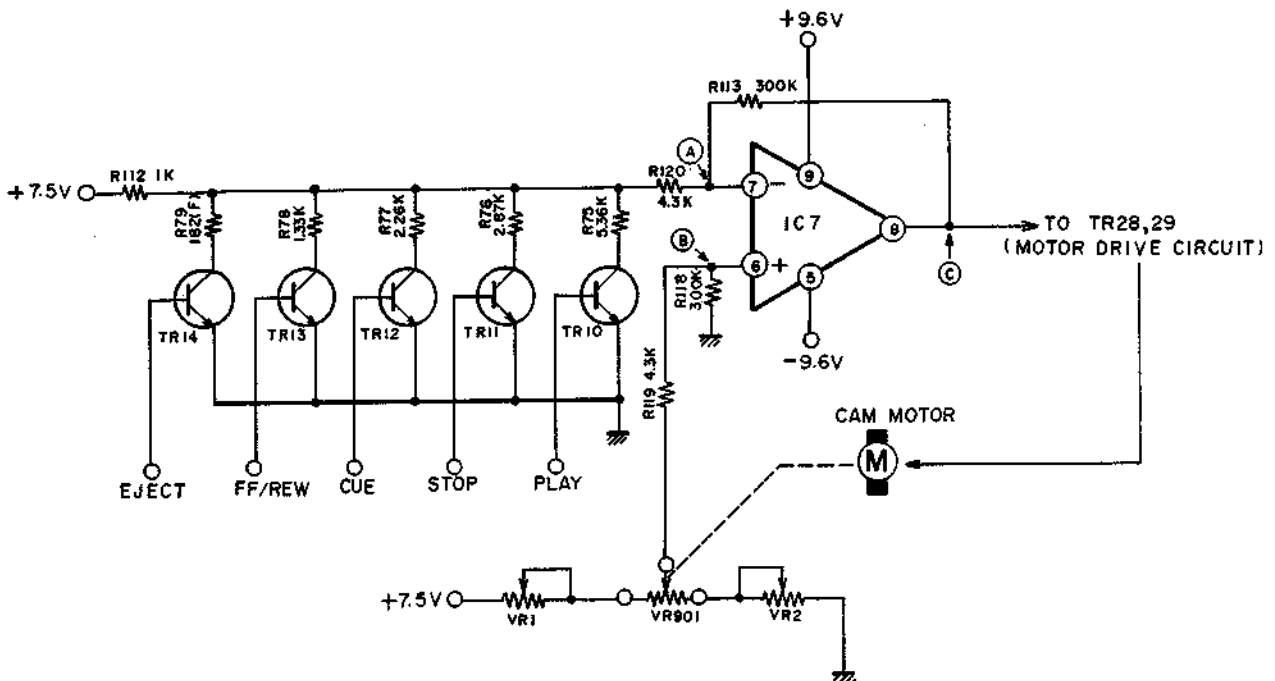

Fig. 6-4 Motor Revolution Indication Circuit

The cam motor is used for the operation of the mechanism. It determines the position of the head base in each mode; power eject mode and auto loading mode. (A plunger used to be employed for this operation.)

CIRCUIT FUNCTIONS:

- 1) TR10~TR14 are turned "ON" by the signal from IC1 (MICOM) in each mode.
The voltage at point (A) is determined in each mode by the difference in the value of resistances of R75~R79 and this voltage is used as the standard voltage of OP Amp (IC7).
At IC7, the voltage at point (A) is compared with that at point (B) and when $A > B$, point (C) becomes "L" (-7V) and when $A < B$, point (C) becomes "H" (+7V) and when $A = B$, point (C) becomes "0" (Approx. -3V~+3V).
- 2) Supposing that point (C) is "H" (+7V).
Referring to System Control P.C.B, TR29 "ON" → TR27 "OFF" → TR25 "OFF" → TR22 "OFF" and

the collector of TR22 becomes "H" while at the same time, TR28 "ON" → TR26 "OFF" → TR21 "ON" and the collector of TR21 becomes "L". Therefore, the motor turns.

- 3) Since the cam motor and VR901 are interlocked with each other, the voltage at point (B) is changed as the motor turns. The motor stops when the voltage at point (A) becomes equal to the voltage at point (B), that is, when the voltage at point (C) becomes "0".
While point (C) is "L" (-7V), the on/off of TR is reverse direction.
- 4) TR19 and 20 are provided for shorting together the two ends of the motor and applying brakes when the voltage at point (C) is "0".
When point (C) is "H" or "L", TR23 is "ON" → TR24 "OFF" → TR19 and 20 "OFF" and, therefore, the motor ends are not shorted. When point (C) is "0", TR23 is "OFF" → TR24 "ON" → TR19 and 20 "ON" and, consequently, the two ends of the motor are shorted together and a brake is applied.

6-5. REEL MOTOR DRIVE CIRCUIT (Refer to Fig. 6-5)

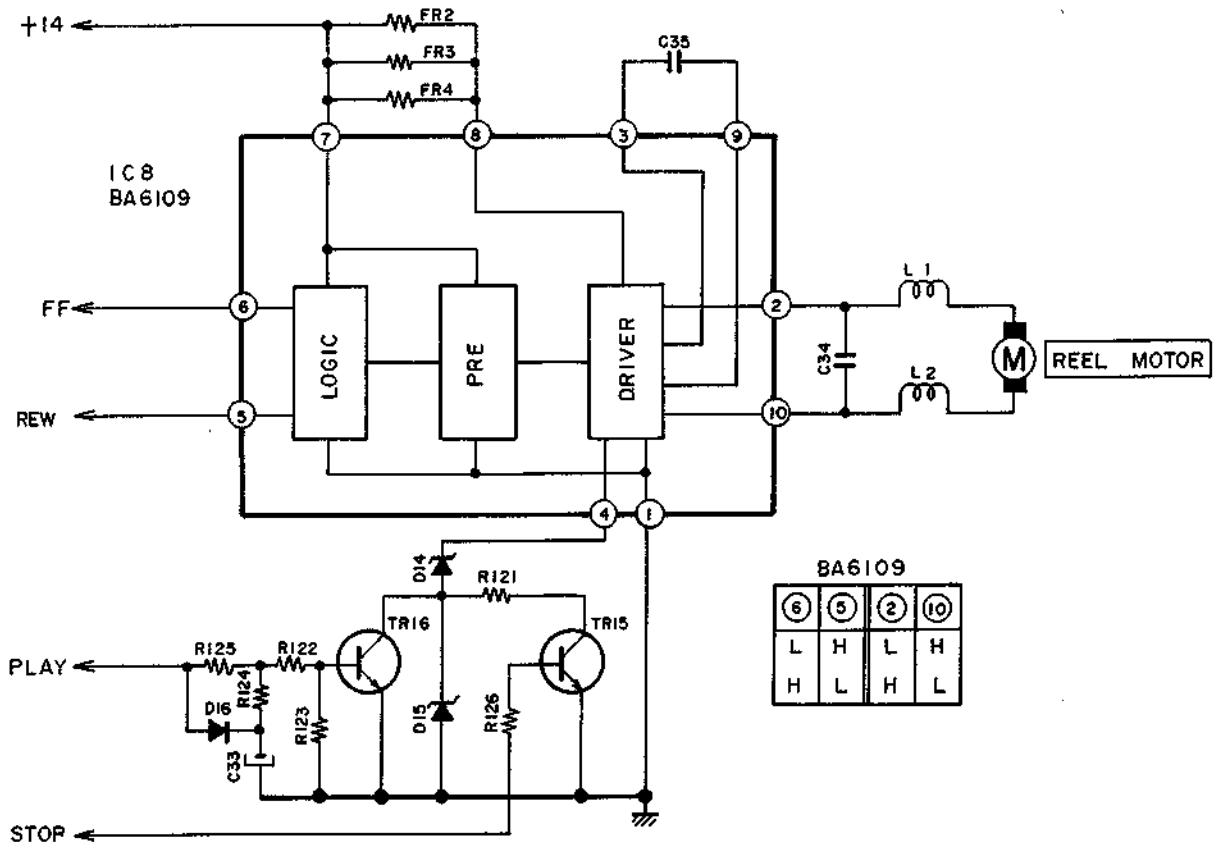

Fig. 6-5 GX-7 Reel Motor Drive Circuit

Functions

IC 8 ⑤ is "H" in REW mode and then ⑩: H and ②: L and the motor turns in the reverse direction.
IC 8 ⑥ is "H" in FF mode and then ②: "H" and ⑩: "L" and the motor turns in the normal direction.

In the PLAY mode, IC 8 ⑥ becomes "H" and the motor turns, but voltage ④ changes to voltage (5V) D16 as TR16 is turned on and voltage ② is reduced to 5V, thus determining the take-up tension.

6-6. AUTO MONITOR SYSTEM

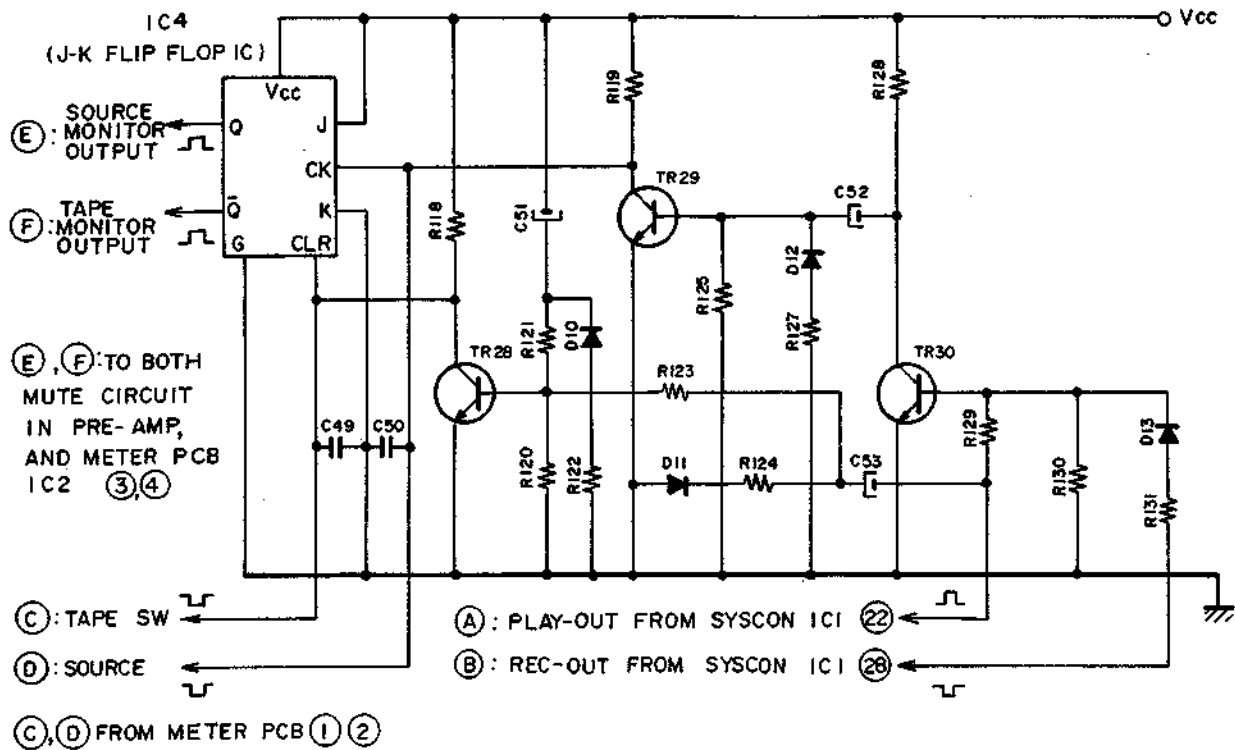

Fig. 6-6

CLR	CK	J	K	Q	Q̄
L	X	H	L	L	H
H	∩L	H	L	H	L
H	—	H	L	Q ₀	Q̄ ₀

IC4 FUNCTION CHART

(*J=H, K=L are fixed in this circuit, X: Don't care, Q₀: Previous level)

Function in each mode		1)	2)	3)	4)	5)	6)
Control signal	Operated SW	Tape	Source	Play	REC./Pause	REC./Play	FF RWD Stop
	(A)	Play	L	L	H	L	H
(B)	REC	H	H	H	L	L	H
(C)	Tape	L	H	H	H	H	H
(D)	Source	H	L	H	H	H	H
(E) (F)	Monitor	Tape	Source	Tape	Source	Tape	No changes

AUTO MONITOR FUNCTION CHART

THE FUNCTION IN EACH MODE (Refer to Fig. 6-6 & Two Charts)

- 1) When tape monitor SW is depressed, the inputs of IC4 are CLR=L, CK=H, K=L, and the outputs are Q=L, \bar{Q} =H. Thus, tape monitor out ⑥ is obtained.
- 2) When source monitor SW is depressed, as the same manner as above, CLR=H, CK=L, J=H, K=L and Q=H, \bar{Q} =L, thus, source - monitor - out ⑤ is obtained.
- 3) In play mode, the play-out ④ of MI-COM (IC1) becomes "H" → TR28 "ON" → CLR=L, Q=L, \bar{Q} =H. Thus, tape-monitor-out is obtained.
- 4) In REC Pause mode the play-out ④ is "L" and the Rec-out ③ becomes "L" TR30 "OFF" → TR29 "ON" to "OFF" → CK "L" to "H". Thus source-monitor-out is obtained.
- 5) In REC Play mode, play-out ④ becomes "H", REC out ③ becomes "L" TR28 "ON" → CLR=L, Q=L, \bar{Q} =H. Thus, tape-monitor-out is obtained.
- 6) In FF, REW or Stop mode, play-out ④ becomes "L" but this signal drains to the ground through D11 and D12. Thus, the monitor will not be changed.

6-7. POWER ON/OFF DETECTOR (Refer to Fig. 6-7) (See Amplifier Schematic Diagram)

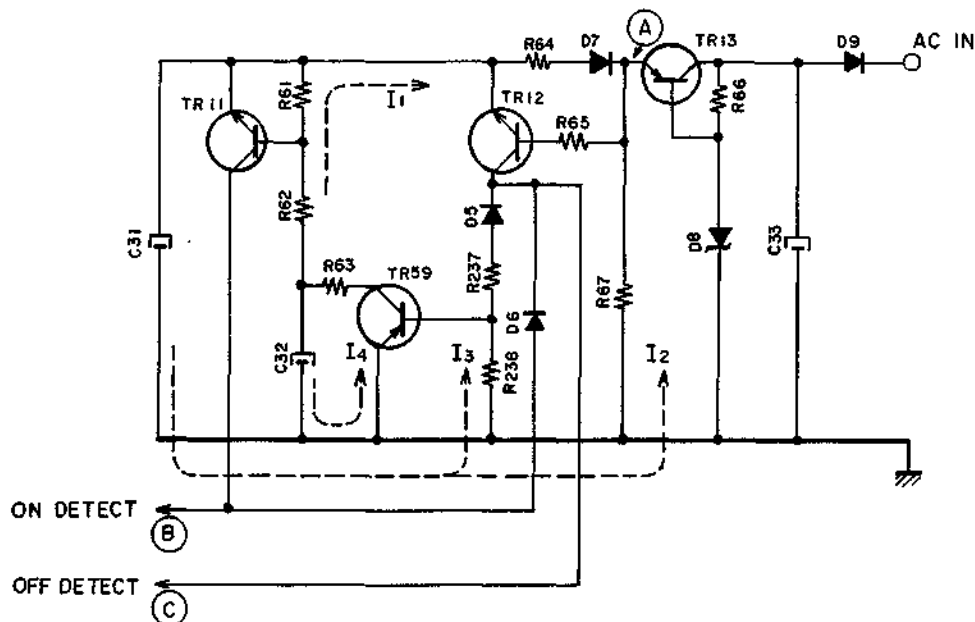

Fig. 6-7

6-7. POWER ON/OFF DETECTOR (Refer to Fig. 6-7) (See Amplifier Schematic Diagram)

- 1) When the power is turned ON, the potential at point ① becomes negative and the charging current I_1 drains as in Fig. 6-7. Then the potential at the base of TR11 becomes negative as well (for about 1.2 sec.).
- 2) When the power is turned OFF, the potential at point ① rises and becomes 0. The discharging

current I_2 from C31 drains as in Fig. 6-7 and the base potential of TR12 becomes higher than the emitter's and TR12 is turned ON.

Thus, the potential of OFF detector line ③ becomes negative, and also the potential of line ② becomes negative as well.

TR59 is turned ON by the discharging current I_3 from C31, and the discharging current I_4 from C32 drains away and the potential of C32 becomes zero and is on stand by for the next power ON.

6-8. MUTE CIRCUIT (Refer to Fig. 6-8)

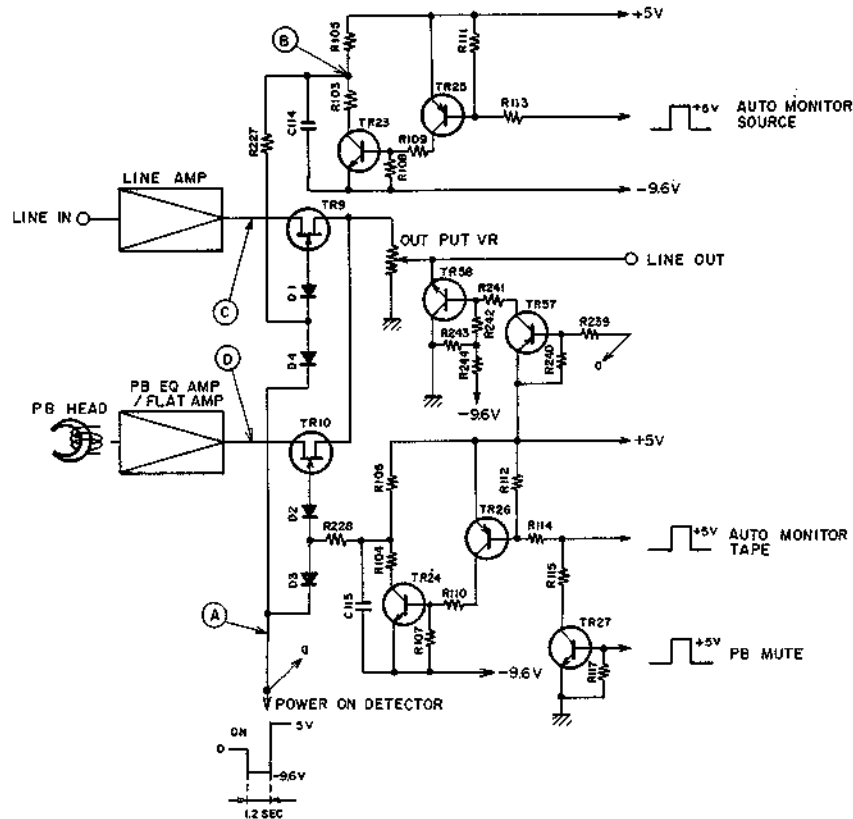

Fig. 6-8

- 1) When the power is turned on, power-on-detector line (A) potential becomes negative for about 1.2 sec, during which time potentials at the gates of TR9, 10 become negative through D1~4. At the same time TR57, 58 are turned "ON". Thus, no signal appears at Line Out.
- 2) When AUTO MONITOR is in SOURCE, SOURCE MONITOR OUTPUT in AUTO MONITOR circuit becomes "H" and TR25 is turned "OFF". Then the base of TR23 becomes "L", point (B) becomes "H" and TR9, is turned "ON". Thus the signal from line (C) appears at Line Out.
- 3) When AUTO MONITOR is in TAPE, in the same manner as item 2), TR10 is turned "ON" and the signal from line (D) appears at Line Out.
- 4) When PB mute signal is applied from SYSCON, TR27 "ON" → TR26 "ON" → TR24 "ON" → TR10 "OFF". Thus no signal appears at Line Out (this function is effective only when AUTO MONITOR is in TAPE position).

6-9. MUTE SIGNAL TO SYSTEMS (Refer to Fig. 6-9)

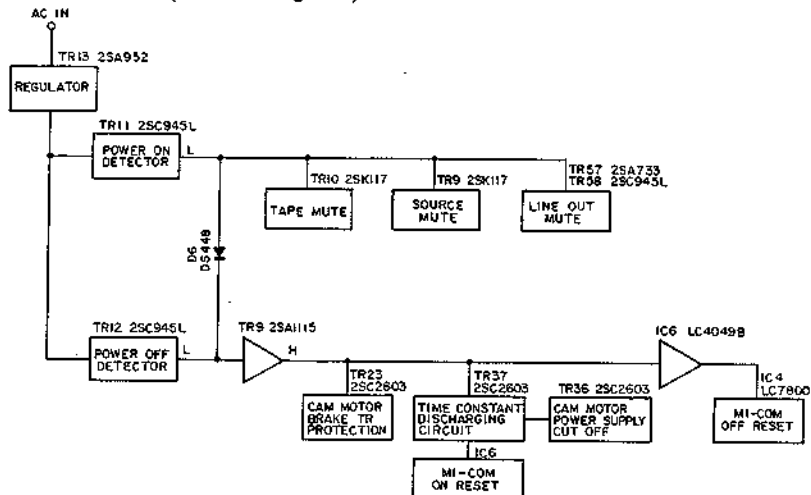

Fig. 6-9

6-10. DOLBY CIRCUIT (Refer to Fig. 6-10, 6-11)

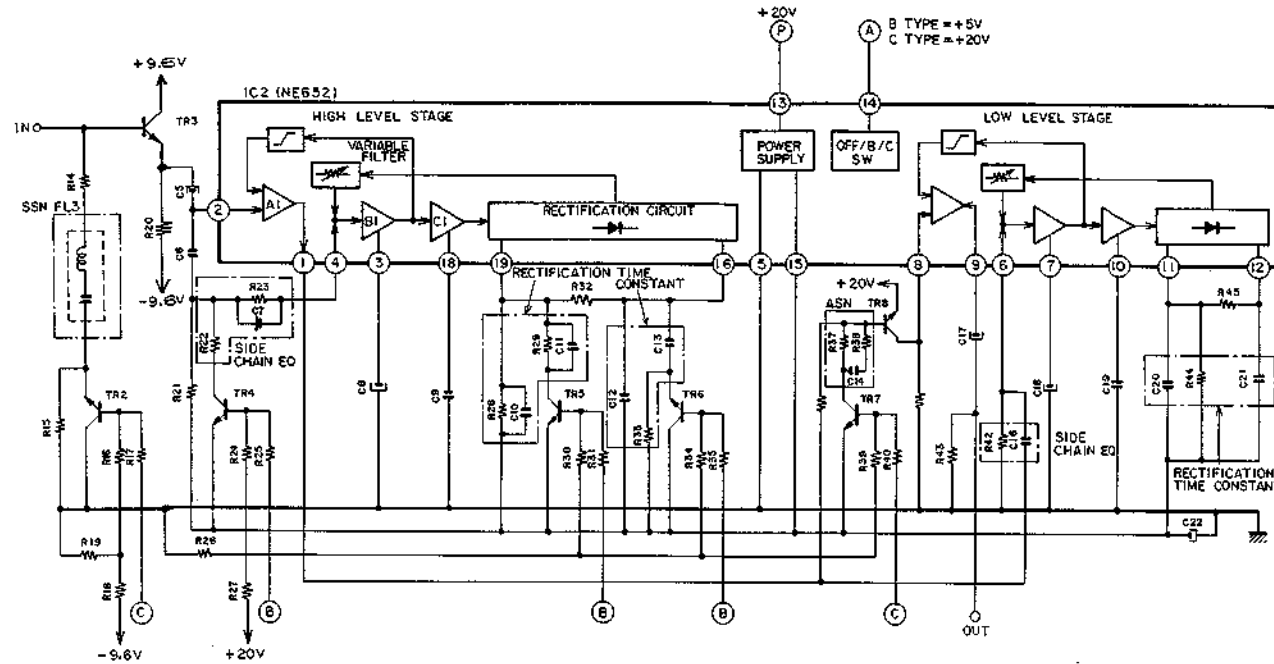

Fig. 6-10 Encode (REC) Circuit

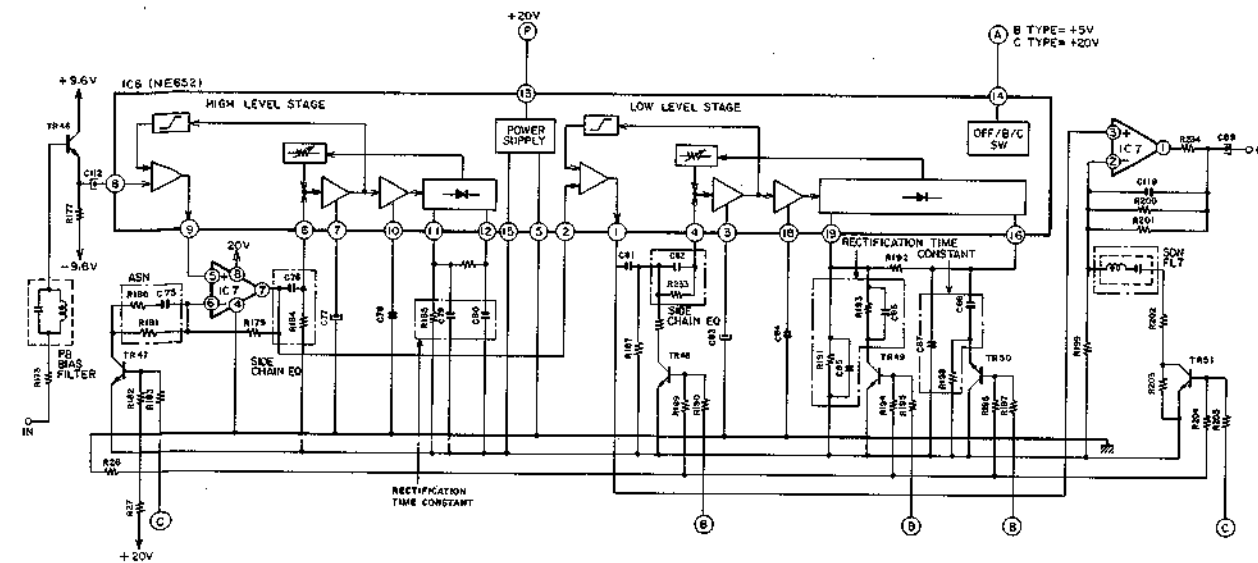

Fig. 6-11 Decode (PB) Circuit

- 1) Fig. 6-10 and Fig. 6-11 show the Dolby NR circuit structure in this model GX-7.
- 2) The C-type encoder and decoder respectively consist of two stages (two Dolby B-type processors with the external constant changed) called high level stage and low level stage.

- 3) In recording (encoding) for C-type, the level at the points ③ becomes "H" and TR2, TR7 are turned ON, also the point ① becomes 20V thus the Dolby circuit changes to C-type.

- 4) The input signal enters the high level stage via amplifier (IC1), SSN (Spectral skewing network), MPX filter, and impedance transducer (TR3). Then, like B-type, the signal is separated into a main pass route and side chain route.

In the main pass route, the signal just goes to the adder (A1) through IC1 Pin ②. In the side chain route, only middle and high frequency signals of low level are passed through the side chain equalizer, then to IC1 Pin ④, B1, C1, rectification and variable filter.

Then the output from this side chain route is combined by the adder (A1) with the signal of the main pass route to obtain the first encode which is outputted at Pin ①. This signal containing emphasis from middle to high frequencies (10dB in the vicinity of 1.5kHz) is sent to the next, low level stage, through ASN (Anti-saturation-network).

The signal inputted into this low level stage is again separated into a main pass route and a side chain route, and a second encoding process is carried out. The encode characteristic in the low level stage is the same as the one in the high level stage, except that its compression starting level (threshold level) is lower, and as a result, the signal containing emphasis of about 20dB from middle to high frequencies of the low level sections appears at the output terminal (pin ⑨).

- 5) In C-type, high frequencies are limited during the recording process, and this is done by SSN and ASN provided in the encoder input.

SSN prevents the processing error by de-emphasizing the frequencies at 10kHz and above by 4dB to reduce the noise reduction operation. As a result, the signal modulation due to the high frequency components can be prevented.

ASN operates only on large amplitude signals above 2kHz and reduces the high frequency saturation of the tape.

- 6) In play-back (decoding), the side chain route is combined in opposite phase to the main pass route, so that a characteristic complementary to the recording characteristic is obtained. Also, the high frequency limitation introduced during encoding by SSN and ASN is released and the high frequencies are emphasized by ASN and SDN (spectral de-skewing network) in decoding.

- 7) In B-type, the points ② become "H" level and TR3, TR4 & TR5 are turned "ON", thus, the turn-over of the side chain equalizer changes to B-type. Also the point ① becomes 5V and the encode (or decode) in the low level stage is switched off, so that the Dolby circuit changes to B-type.

VII. MECHANICAL ADJUSTMENT

7-1. PINCH ROLLER PRESSURE MEASUREMENT (Refer to Fig. 7-1)

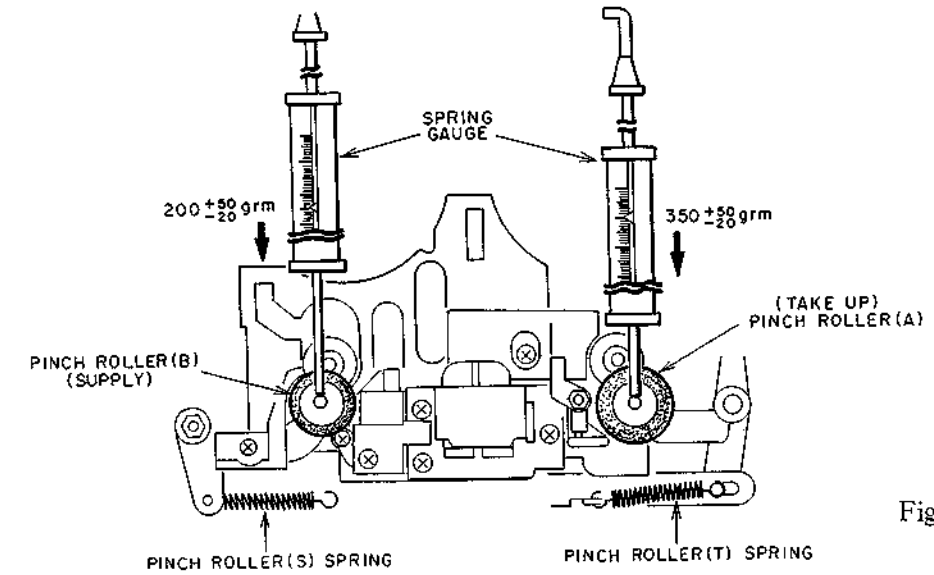

Fig. 7-1

Put in PLAY Mode. Push pinch roller arm down with the spring gauge, push the pinch roller 1 - 2mm away from the capstan and release slowly. Read the spring gauge at the moment the pinch roller touches the capstan and begins to rotate.

Specified pressure: 350 ± 50 gram (Take-up)

200 ± 50 gram (Supply)

If the correct measurement is not obtained, replace the pinch roller spring.

7-2. TAPE SPEED ADJUSTMENT (Refer to Fig. 7-2)

- 1) Connect a frequency counter to line output terminals.
- 2) Playback a 3150Hz Pre-recorded test tape (AT-751263) or 1000Hz Pre-recorded test tape (AT-750774), and adjust tape speed adjustment pre-set (Syscon VR1 50K) to obtain a tape speed of 3150Hz $\pm 1\%$ or 1000Hz $\pm 1\%$.

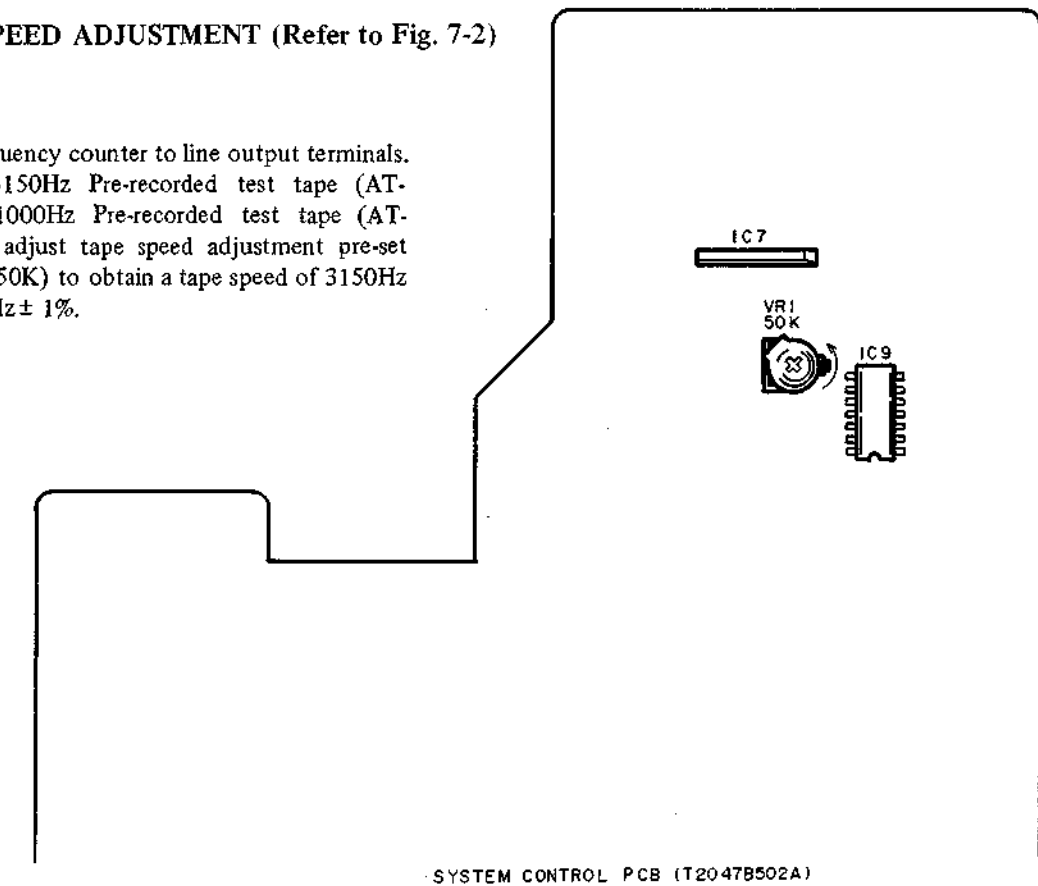

SYSTEM CONTROL PCB (T2047B502A)

Fig. 7-2

7-3. HOW TO INSTAL VARIABLE RESISTOR (VR901) AND CAM WHEEL

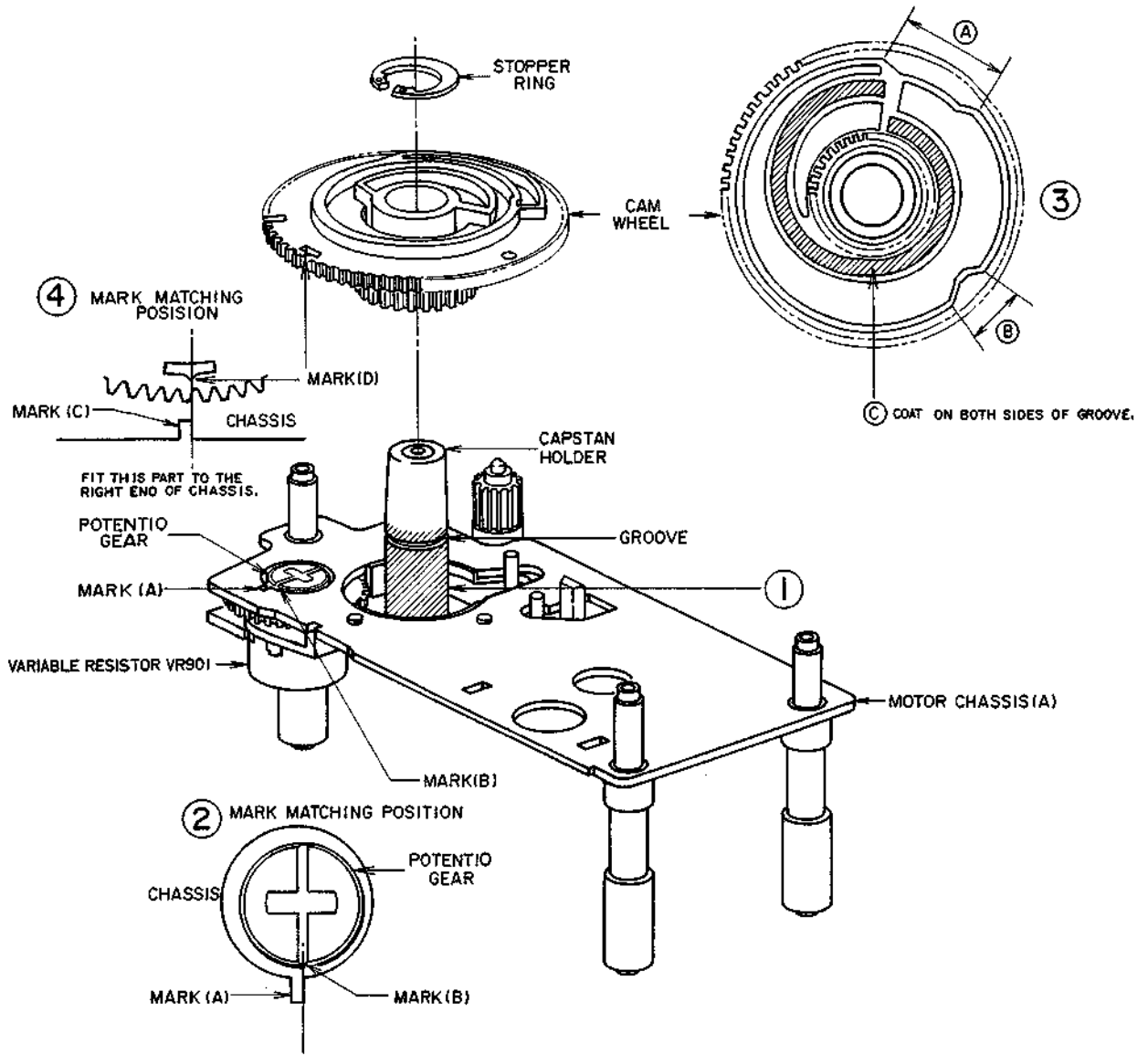

Fig. 7-3

- 1) Apply Molybdenum coat on the capstan holder. Apply Molybdenum coat on the area of 360° from the bottom to the upside 2mm of groove as shown in the figure. (Fig. 7-3 ①)
- 2) Fitting position volume (potentio gear)
Fit the right end of Mark (A) to the center of Mark (B) as shown in the figure. (Fig. 7-3 ②)
- 3) Apply Molybdenum coat on (A), (B) and (C) shown in Fig. 7-3 ③.
- 4) Set the cam wheel on the capstan wheel (Ensure that the cam wheel and potentio gear are meshed properly). When the cam wheel is set properly, fit the center of Mark (D) to the right end of Mark (C). (Fig. 7-3 ④)
- 5) Fit the stopper ring in the groove of the capstan holder.

CAUTIONS:

1. Make sure that the teeth on the periphery of the cam wheel and the cam itself are absolutely free from any scratch, flaw, cut, etc.
2. Make sure that Molybdenum coat is applied on the specified area only.

**7-4. POTENTIOMETER PRESET VOLTAGE
ADJUSTMENT (Refer to Fig. 7-4)**

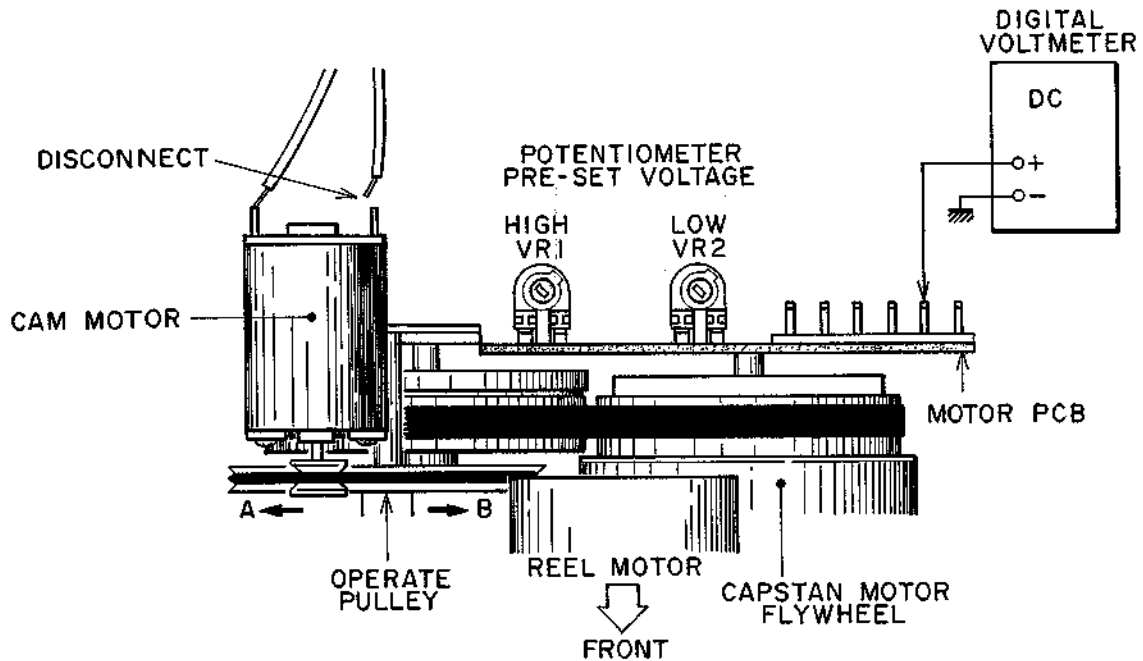

Fig. 7-4

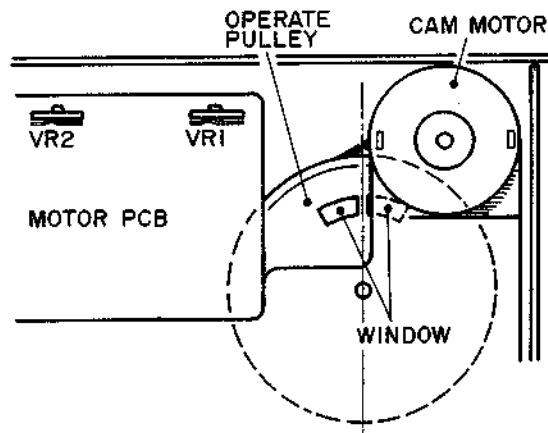

Fig. 7-5 Position of Operate Pulley in STOP Mode

1) LOW VOLTAGE ADJUSTMENT

- a. With power OFF, remove the connecting cord of the cam motor and turn the operate pulley fully with your fingers in A direction.
- b. Connect the digital voltmeter as shown in Fig. 7-4.
- c. With power ON, adjust VR2 so that the voltage reading is 0.78V (DC).

2) HIGH VOLTAGE ADJUSTMENT

- a. With power OFF, turn the operate pulley fully with your fingers in B direction.
- b. With power ON, adjust VR1 so that the voltage reading is 6.73V (DC).

3) Repeat Items 1) and 2)

- 4) a. With Power OFF, connect the connecting cord of the motor.
- b. Remove the digital voltmeter.

5) a. Set power to ON.

- b. Adjust VR1 slightly so that a center line between windows of the operate pulley will be directly above the pulley centre during STOP Mode. (Fig. 7-5)
- c. Remove the cassette lid and set the AUTO SYSTEM switch to IPLS Mode.
- d. Confirm that the head and pinch roller do not move up and down when the FF and REW switches are alternately depressed.
- e. Turn the reel with fingers in STOP Mode to check that the brake works sufficiently. When the brake acts normally, the take-up reel does not turn clockwise while the supply reel does not rotate counterclockwise.

VIII. HEAD ADJUSTMENT

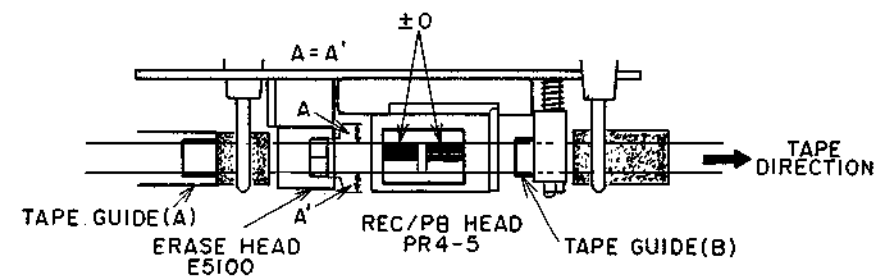
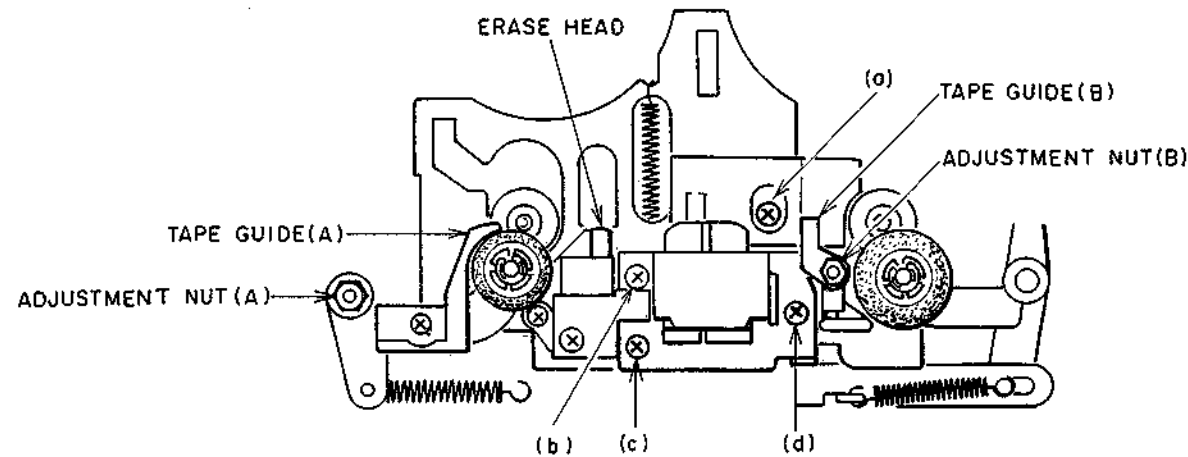

Fig. 8-1

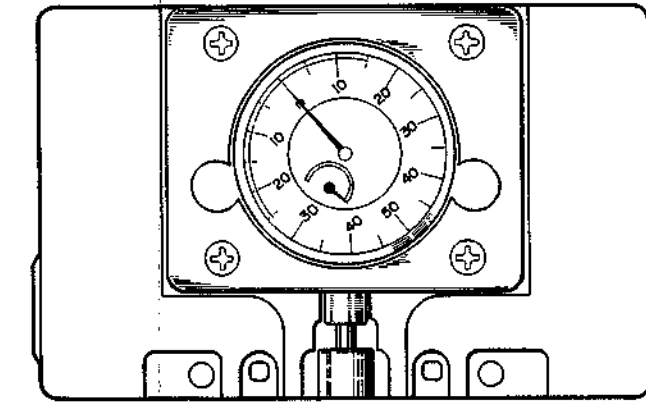

Fig. 8-2 Cassette Head Projection Gauge (AJ-751180)

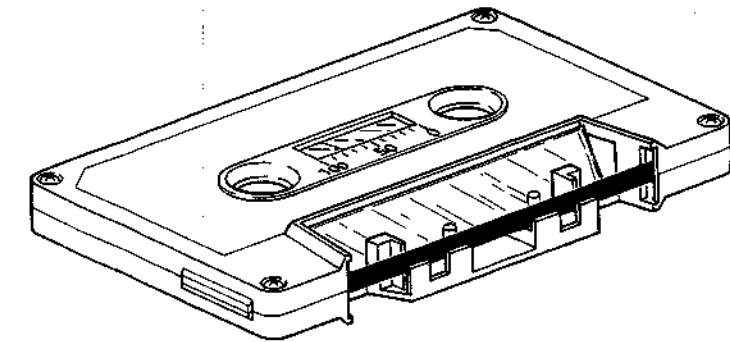

Fig. 8-3 Mirror Cassette Tape (AJ-751178)

8-1. REC/PB HEAD PROJECTION ADJUSTMENT (Refer to Fig. 8-1, 8-2)

Use the cassette head projection gauge (AJ-751180) and select **PLAY** mode. Loosen the screw (a) and adjust so that the gauge indication at that time will be 3.2 ± 0.05 mm. After adjustment, apply paint-lock on the screw (a).

8-2. TAPE GUIDE HEIGHT ADJUSTMENT (Refer to Fig. 8-1, 8-3)

- 1) Use the mirror cassette tape (AJ-751178) and select **PLAY** mode.
- 2) Adjust the tape guide (A) so that the parts of the erase head visible on both sides of the tape (A and A' in Fig. 8-1) are equal. For the adjustment, use the adjustment nut (A).
- 3) Adjust the tape guide (B) so that the tape runs smoothly and is not hitched by the tape guide. For the adjustment, use the adjustment nut (B).
- 4) After adjustment, paint-lock the adjustment nuts (A) and (B).

8-3. REC/PB HEAD HEIGHT ADJUSTMENT (Refer to Fig. 8-1, 8-3)

- 1) Use the mirror cassette tape and select **PLAY** mode.
- 2) Adjust the screws (b), (c) and (d) so that the upper edge of the REC/PB head Lch core and the upper side of the tape are in alignment.
- 3) Playback the head height adjustment tape (4TR1,000 Hz) (AT-750775), and fine-adjust the screws (b), (c) and (d) so that the maximum output is obtained for both channels.

8-4. REC/PB HEAD AZIMUTH ALIGNMENT ADJUSTMENT (Refer to Fig. 8-1)

- 1) Playback a 10kHz Head Azimuth Alignment Tape (AT-750778) and adjust the screw (d) until the output levels of both channels are at maximum.
- 2) Record a 10kHz, -20VU signal from the audio frequency oscillator.
- 3) Rewind and check for any fluctuation in the output level at playback.
- 4) After adjustment, paint-lock the screws (b), (c) and (d).

NOTE:

1. Be sure to clean the heads prior to head adjustment.
2. Be careful not to use a magnetized driver or other magnetized tools in the vicinity of the heads.
3. Be sure to demagnetize the heads with a head demagnetizer before and after head adjustment.

IX. AMPLIFIER ADJUSTMENT

PRE. AMP. P.C. BOARD (T2047A501A)

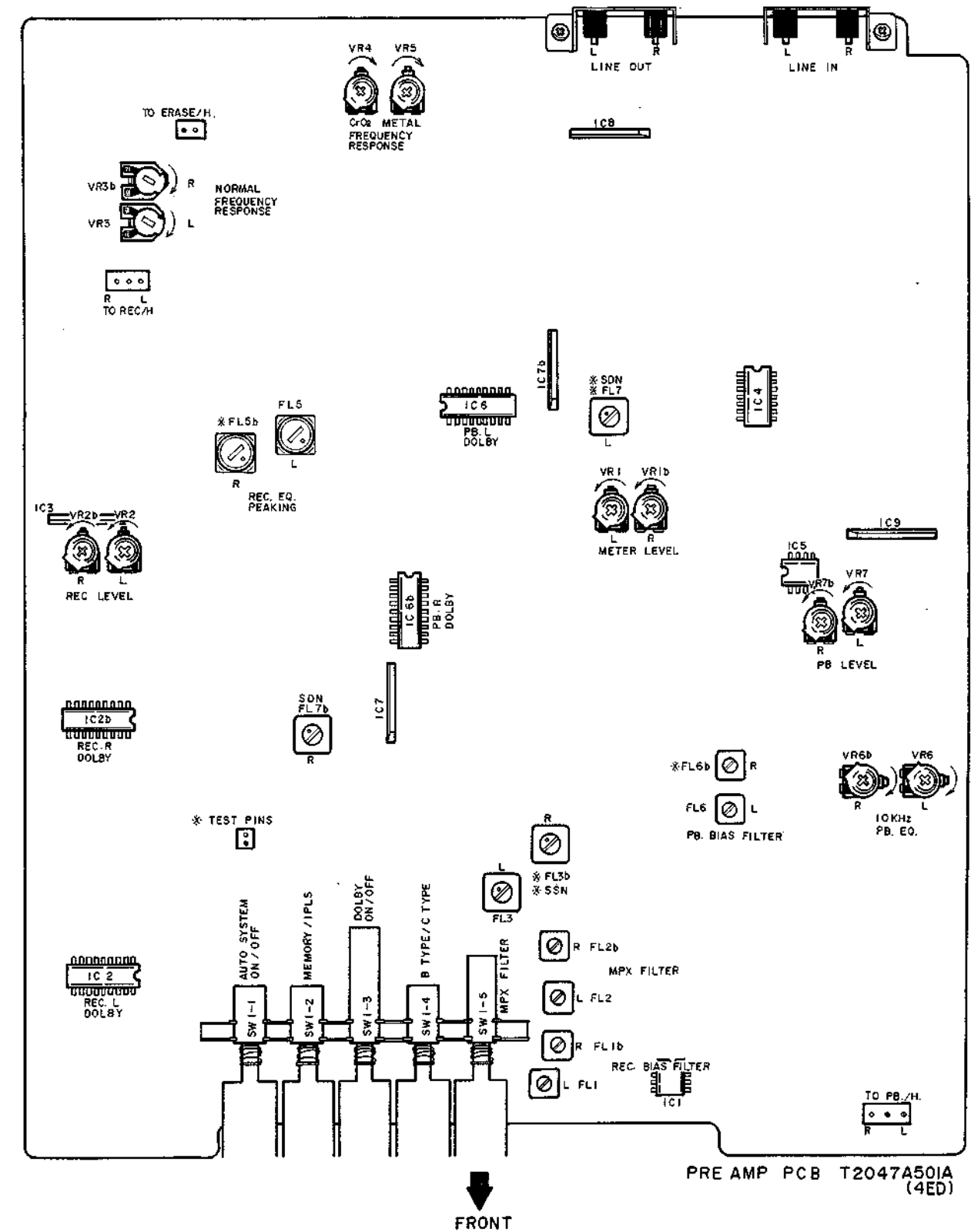

* Use alligator clip to short-circuit test pins.
 FL3, 5, 6, 7 were Pre-adjusted at the factory.
 SDN (Spectral de-skewing network)
 SSN (Spectral skewing network)
 ↗ direction increases the level (bias will be shallower)

Fig. 9-1

Caution: Read remarks especially for the adjustments in step, 1, 2 & 6.

STEP	ADJUSTMENT ITEM	TEST TAPE SUPPLY SIGNAL	MODE	ADJUSTMENT PARTS	RESULT	REMARKS
1	PB Level	333Hz (AT-750773) 315Hz (AT-750773)	PB	VR7	-6.1±0.2dBm -5.5±0.2dBm	Short-circuit Test pins. Dolby B on
2	PB EQ	10kHz (AT-750778) 10kHz (AT-750778) -17dB	PB	VR6	-29.5±1.5dBm -21.5±1.5dBm	Short-circuit Test pins. Dolby B on
3	Normal Position Frequency Response	Normal Blank Tape 1kHz, 10kHz -25.5dBm	REC/PB	VR3	1kHz to 10kHz Flat ±0.2dBm	
4	CrO ₂ Position Frequency Response	CrO ₂ Blank Tape 1kHz, 10kHz -25.5dBm	REC/PB	VR4	1kHz to 10kHz Flat ±0.5dBm	
5	Metal Position Frequency Response	Metal Blank Tape 1kHz, 10kHz -25.5dBm	REC/PB	VR5	1kHz to 10kHz Flat ±0.5dBm	
6	Rec Level	Normal Blank Tape 1kHz -5.5dBm	REC/PB	VR2	-5.5±0.2dBm	Short-circuit Test pins. Dolby B on
7	MPX Filter	19kHz From Oscillator	REC	FL2	Minimum Output	MPX Filter ON
8	Bias Filter	No Signal Input	REC	FL1	Minimum Output	Sec Rec Volume to Maximum
9	Meter Sensitivity	1kHz (-5.5dBm) From Oscillator	REC	VR1	0dB Indication	

- NOTE: 1. Except for Step 7, Set MPX Filter switch to OFF position.
 2. Use the following cassette measuring tapes.
 Normal Tape: Maxell UD C-60
 CrO₂ Tape : TDK SA C-60
 Metal Tape : TDK MA-C C-60
 3. Refer to Fig. 9-1 for the adjustments.

X. DC RESISTANCE OF HEADS

Description	Name	DC Resistance
REC/PB Head	PR4-5	PB: 340 Ohms ± 10% REC: 320 Ohms ± 10%
Erase Head	E5100	3.0 Ohms

XI. CLASSIFICATION OF VARIOUS P.C BOARDS

1. P.C BOARD TITLES AND IDENTIFICATION NUMBERS

P.C BOARD TITLE	P.C. BOARD NUMBER
Detector	T2029D5030
FG	M3103C7130
Filter	T2029D5040
Head Phone	T2047A501D
Meter	T2047A5030 (3ED)
Motor	T3130C726A (2ED)
Output Volume	T2047A501C
Potention	M3103C726B
Pre Amp	T2047A501A (4ED)
Rec Volume	T2047A501B
Remote Control	T2047B502B
Syscon	T2047B502A (4ED)
Timer	T2047B502C

2. COMPOSITION OF VARIOUS P.C. BOARDS

1) PRE AMP P.C. BOARD T2047A501A (4ED), OUTPUT VOLUME P.C. BOARD T2047A501C, HEAD PHONE P.C. BOARD T2047A501D, and REC VOLUME P.C. BOARD T2047A501B

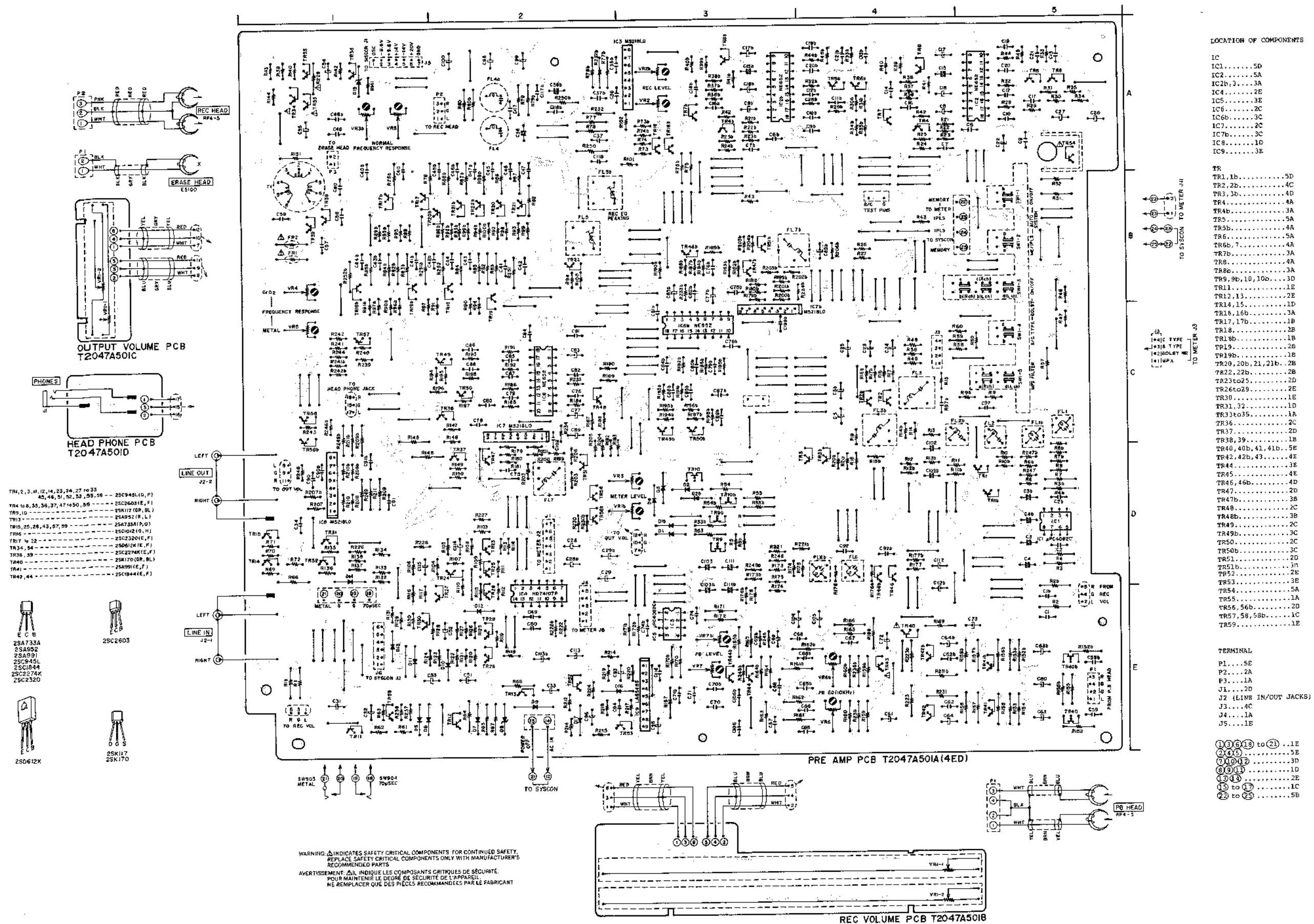

2) SYSCON P.C. BOARD T2047B502A (4ED), FILTER P.C. BOARD T2029D5040, TIMER P.C. BOARD T2047B502C, REMOTE CONTROL P.C. BOARD T2047B502B, and DETECTOR P.C. BOARD T2029D5030

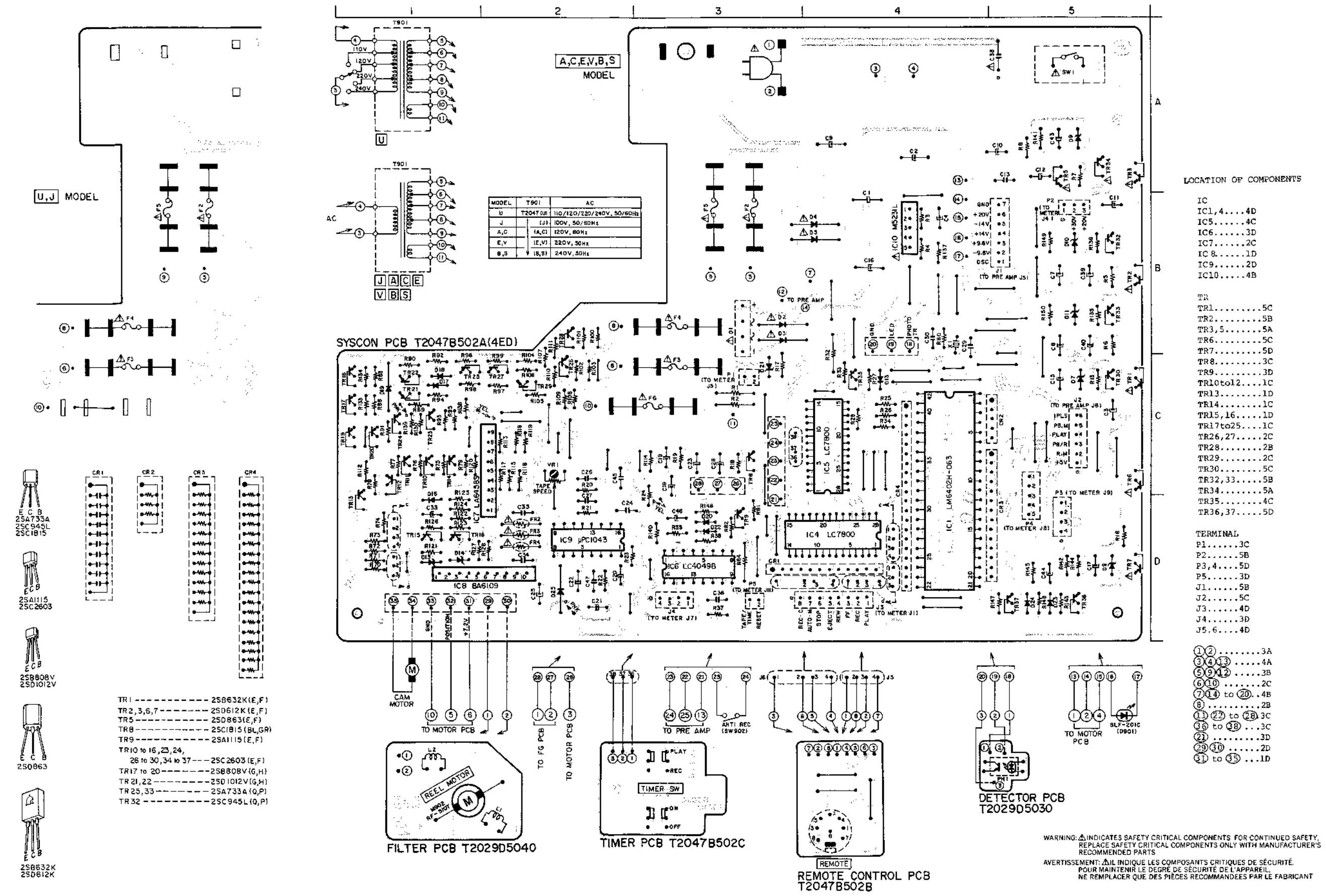

3) MOTOR P.C. BOARD M3103C726A (2ED), POTENTION P.C. BOARD M3103C726B, and FG P.C. BOARD M3103C7130.

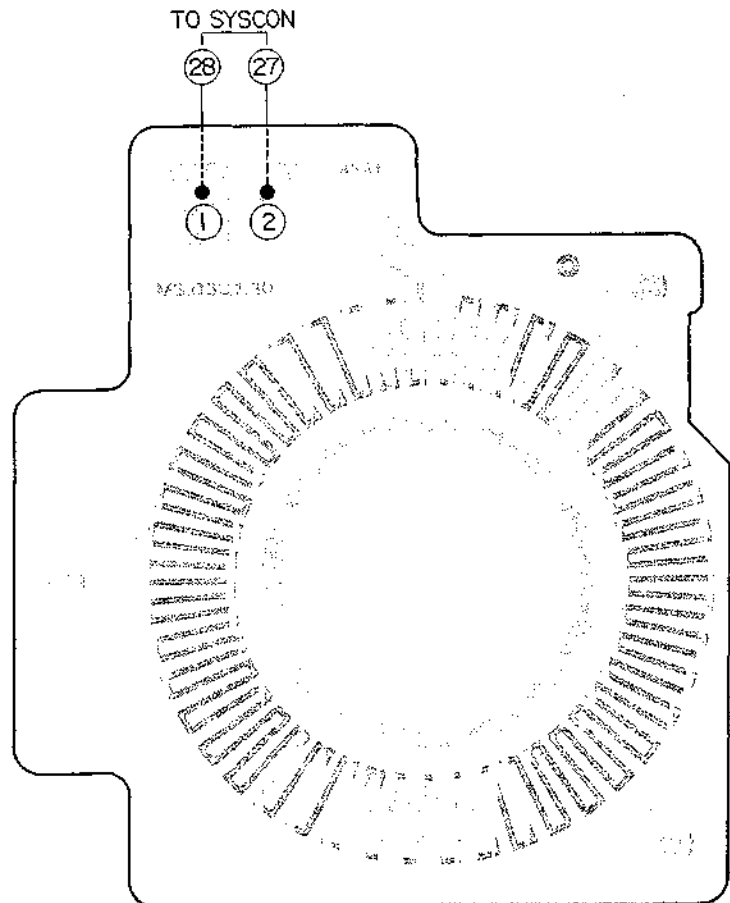
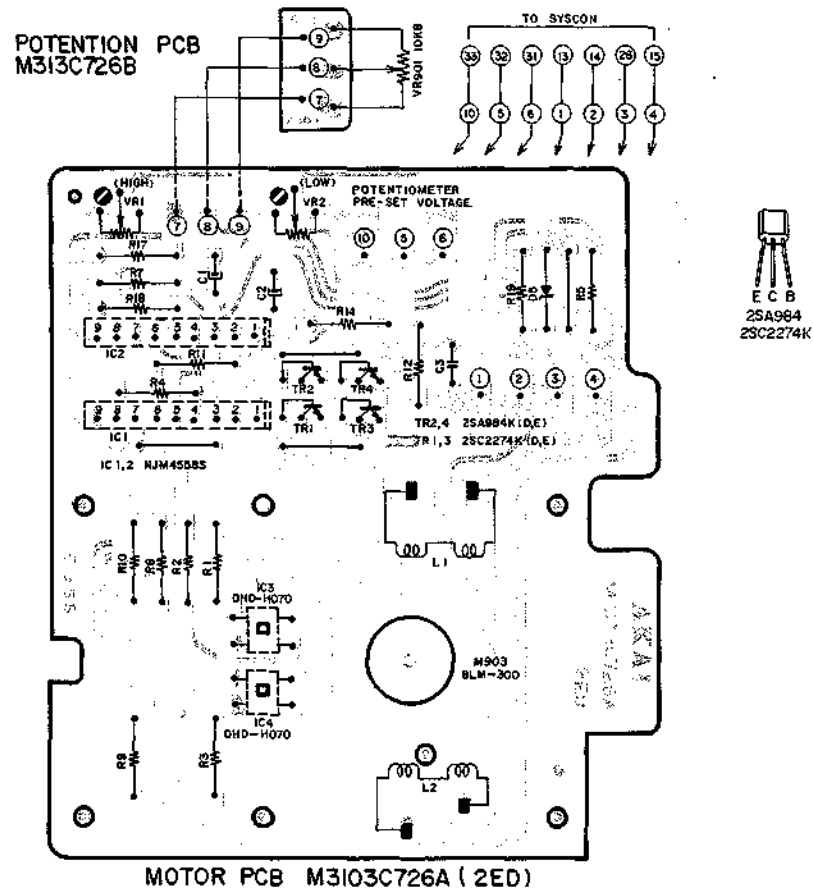

SECTION 2

PARTS LIST

TABLE OF CONTENTS

RECOMMENDED SPARE PARTS	31
1. MECHA BLOCK	32
2. MOTOR BLOCK	34
3. PRE AMP P.C BOARD BLOCK	35
4. SYSCON P.C BOARD BLOCK	35
5. METER/OPERATE P.C BOARD BLOCK	36
6. MOTOR P.C BOARD BLOCK	36
7. ASSEMBLY BLOCK	36
8. FINALY ASSEMBLY BLOCK	38
INDEX	39

Resistor and Capacitor which is not listed in this parts list, please refer to
COMMON LIST FOR SERVICE PARTS.

ATTENTION

1. When placing an order for parts, be sure to list the parts no., model no., and description. There are instances in which if any of this information is omitted, parts cannot be shipped or the wrong parts will be delivered.
2. Please be careful not to make a mistake in the parts no. If the parts no. is in error, a part different from the one ordered may be delivered.
3. Because parts number and parts unit supply in the Preliminary Parts List may be partially changed, please use this parts list for all future reference.

HOW TO USE THIS PARTS LIST

1. This Parts List shows the parts that are considered necessary for repairs. Other parts, such as resistors and capacitors, are shown in the "Common List for Service Parts". Select and order such parts from the "Common List for Service Parts".
2. The Recommended Spare Parts shows those parts in the Parts List which are considered particularly important for service.
3. Parts not shown in the Parts List and "Common List for Service Parts" will not be supplied in principle.
4. How to read list
 - a) Mechanism Block
 - b) P.C Board Block

2. HEAD BASE BLOCK

REF. NO.	PARTS NO.	DESCRIPTION
2-1x	BH-T2023A320A	HEAD BASE BLOCK GX-F66R
2-2	HP-H2206A010A	HEAD R/P PR4-8FU C
2-3	ZS-477876	PAN20x03STL CMT
2-4	ZS-536488	BID20x08STL CMT
2-5	ZG-402895	CS ANGLE ADJUST SPRING

SP (Service Parts) Classification
 A small "x" indicates the inability to show that particular part in the Photo or Illustration.
 This number corresponds with the individual parts index number in that figure
 This number corresponds with the Figure Number

6. SYS. CON. P.C BOARD BLOCK

REF. NO.	PARTS NO.	DESCRIPTION
6-1	BA-T2034A070A	PC SYS CON BLK GX-F44R
6-IC1	EI-324536	IC HD14049BP
6-IC2	EI-336801	IC MB8841-564M
6-IC3	EI-331661	IC SN7405N
6-IC4	EI-336725	IC M54527P
6-TR1to4	ET-200985	TR 2SC2603 F,G
6-TR5to28	ET-554657	TR 2SA733A P,Q
6-D1	ED-318292	D SILICON H 1S2473T-77 T26
6-D2to4	ED-308952	D GERMA V 1K34A-LR F07
6-D5to10	ED-318292	D SILICON H 1S2473T-77 T26
6-X1	EI-318384	OSC X'TAL NC-18C 3.579545MHZ

SP (Service Parts) Classification
 This reference numbers corresponds with symbol numbers of Schematic Diagrams.

5. Both the kind of part and installation position can be determined by the Parts Number. To determine where a parts number is listed, utilize Parts Index at end of Parts List. It is necessary first of all to find the Parts Number. This can be accomplished by using the Reference Number listed at right of parts number in the Parts Index.

WARNING

▲ INDICATES SAFETY CRITICAL COMPONENTS FOR CONTINUED SAFETY. REPLACE SAFETY CRITICAL COMPONENTS ONLY WITH MANUFACTURE'S RECOMMENDED PARTS

AVERTISSEMENT

▲ IL INDIQUE LES COMPOSANTS CRITIQUES DE SÉCURITÉ. POUR MAINTENIR LE DEGRÉ DE SÉCURITÉ DE L'APPAREIL, NE REMPLACER QUE DES PIÈCES RECOMMANDÉES PAR LE FABRICANT

RECOMMENDED SPARE PARTS

Because, if the parts listed below are on hand, almost any repair can be accomplished, we suggest that you stock these Recommended Spare Parts Items.

REF. NO.	PARTS NO.	DESCRIPTION
1	BM-B337064	△ MOTOR OPERATION (PULLEY) PART
2	BM-T2030A120A	△ REEL MOTOR BLK GX-F71
3	BT-337829	△ TRANS POWER T2047(A,C)
4	BT-337831	△ TRANS POWER T2047(B,S)
5	BT-337830	△ TRANS POWER T2047(E,V)
6	BT-337828	△ TRANS POWER T2047(J)
7	BT-337827	△ TRANS POWER T2047(U)
8	EC-332052	C EC V F05 NP SM 4R7M 35DC
9	EC-337017	OSC CE CSB800A 0.8MHz
10	ED-337010	D LED SLF-201C GRN
11	ED-344280	D SILICON GMA-01-FY2 F05
12	ED-301911	D SILICON H DS448
13	ED-323979	D SILICON W03B F12 100/1.0A
14	ED-322238	D SILICON 1B4B41 100/1.0A
15	ED-344131	D ZENER H HZ11FA F10 A3
16	ED-338561	D ZENER H HZ2FA F10 B2
17	ED-346433	D ZENER H HZ4FA F10 B2
18	ED-338403	D ZENER V HZ11B-1S1
19	ED-346264	D ZENER V HZ11LS1 F05 B2
20	ED-344763	D ZENER V HZ22-2S1
21	ED-337289	D ZENER V HZ5A-1S1
22	ED-337259	D ZENER V HZ6A-3S1
23	ED-337867	D ZENER V HZ6C-2S1
24	ED-337021	D ZENER V HZ9A-1S1
25	EF-339906	△ FUSE SEMKO T 250V 0.25A
26	EF-300591	FUSE EAWK T 250V 0.50A
27	EF-330461	FUSE GGS A 250V 0.50A
28	EF-623103	FUSE SEMKO T 250V 1A
29	EF-306125	FUSE TSC A 250V 0.31A
30	EF-306949	FUSE TSC A 250V 1.25A
31	EF-306088	FUSE TSC 125V 0.31A
32	EF-309392	FUSE TSC 125V 1.25A
33	EI-337568	HOLE ELEMENT DHD-H070
34	EI-330352	IC BA6109
35	EI-337845	IC BA6146 M
36	EI-322993	IC HD74107P
37	EI-336761	IC LA6458S
38	EI-337013	IC LB1290
39	EI-337009	IC LC4049B
40	EI-337008	IC LC7800
41	EI-337006	IC LM6402H-063
42	EI-337228	IC M5218L0
43	EI-337842	IC M5231L
44	EI-337835	IC NE652
45	EI-201940	IC NJM4558S
46	EI-336992	IC μPC1043C
47	EI-337360	IC μPC4082C
48	EM-337844	IND FL BG-131Z DOUBLE
49	EO-337838	COIL OSC 1 32-5007-12 100KHz
50	EO-315758	COIL TUN 1 100S-431 100KHz
51	EO-336738	COIL TUN 1 102AK-004 19.8KHz
52	EO-346230	COIL VARI 1 RX-22MH 22mH
53	ER-200972	△ R FUSE ERD2FC S10 1/4W
54	ER-200595	△ R FUSE ERD2FC S10 1/4W 5R6J
55	ER-328490	FILTER DB D07-001K 19KHz
56	ER-328491	FILTER DB D07-003K 100KHz
57	ER-337861	R S-FIX H RVF8P01 3P 302
58	ES-346260	△ SW PUSH SPH121A 2-02-02N
59	ES-305733	△ SW SELECTOR HXW0131-260
60	ES-337839	SE PUSH ESB-62694 5THROW
61	ES-336990	SW LEAF BSW-169 01-1 NO
62	ES-344270	SW PUSH SDDL1P 01-1
63	ES-336780	SW TACT KHH10902
64	ET-311977	PHOTO SENSOR SPI-201
65	ET-321016	TR FET 2SK117 GR,BL
66	ET-341400	TR FET 2SK170 BL,GR
67	ET-200558	TR 2SA1115 E,F
68	ET-554657	TR 2SA733A P,Q
69	ET-302296	TR 2SA952 K,L
70	ET-337012	TR 2SA984K D,E
71	ET-338447	TR 2SA991 E,F
72	ET-322598	TR 2SB632K E,F
73	ET-336997	TR 2SB808-V G,H
74	ET-308976	TR 2SC1815 BL,GR
75	ET-308954	TR 2SC1844 E,F

REF. NO.	PARTS NO.	DESCRIPTION
76	ET-337011	TR 2SC2274K D,E
77	ET-309353	TR 2SC2274K E,F
78	ET-328578	TR 2SC2320 E,F
79	ET-200505	TR 2SC2603 E,F
80	ET-639437	TR 2SC945L Q,P
81	ET-328868	TR 2SD1012-V G,H
82	ET-310148	TR 2SD612K E,F
83	ET-318239	TR 2SD863 E,F
84	EV-337995	R S-FIX H RVF8P01 3P 103
85	EV-337996	R S-FIX H RVF8P01 3P 104
86	EV-345781	R S-FIX H RVF8P01 3P 202
87	EV-338588	R S-FIX H RVF8P01 3P 503
88	EV-330531	R S-FIX H TM8KV2-1S 3P 0.50W 503
89	EV-464253	R S-FIX V V8K1-1 3P 202
90	EV-337052	VR ROTARY 16L10XOR B103
91	EV-337840	VR SLIDE 100P2WVOA A503
92	EV-337841	VR SLIDE 30P2SVOA B103
93	HE-337837	HEAD E E51005770
94	HP-H2402A010A	HEAD COMBO PR4-5
95	MB-336026	BELT CAPSTAN
96	MB-336021	BELT OPERATION
97	MP-336153	PINCH ROLLER (A)
98	MP-336204	PINCH ROLLER (B)
99	TC-336605	WIND IDLER ASSY

MECHA BLOCK

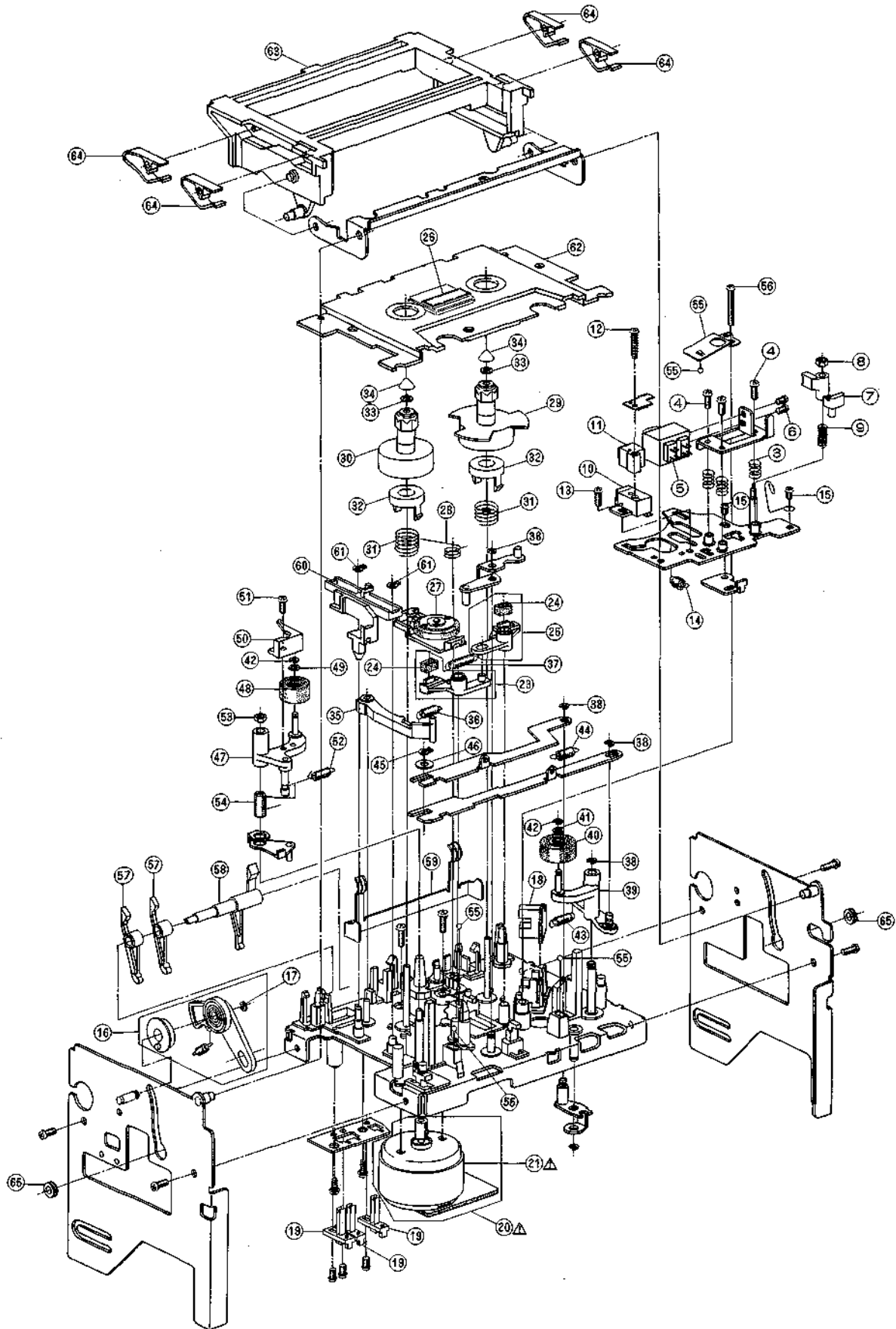

1. MECHA BLOCK

REF. NO.	PARTS NO.	DESCRIPTION	REF. NO.	PARTS NO.	DESCRIPTION
			1-59	ML-336159	LEVER DETECTION (A)
			1-60	ZG-336160	SP PLATE CASSETTE HOLDER (A)
			1-61	TC-336161	SLIDE EJECT
			1-62	ZW-329422	RING CS0300
			1-63	SP-336162A	LID DECORATION PLATE (A)
			1-64	SP-336163	LID CASE
			1-65	ZG-336615	SP PLATE CASSETTE HOLDER (B)
			1-66	SZ-336166	COLLAR LID
1-1x	BZ-T2047A020A	MECHA BLOCK GX-7			
	HEAD BLOCK				
1-2x	BH-T2047A060A	HEAD BLK GX-7			
1-3	ZG-336127	SP PUSH HEAD			
1-4	ZS-608095	PAN20x05STL CMT			
1-5	HP-H2402A010A	HEAD COMBO PR4-5			
1-6	ZS-477876	PAN20x03STL CMT			
1-7	HZ-336129	GUIDE TAPE			
1-8	ZW-618884	N20STL CMT 1			
1-9	ZG-336130	SP PUSH GUIDE			
1-10	HZ-343000	HOLDER E HEAD			
1-11	HE-337837	HEAD E E51005770			
1-12	ZS-342086	PLX PAN26x12STL CMT			
1-13	ZS-499331	PAN23x05STL CMT			
1-14	ZG-341972	SP PULL HEAD RETURN			
1-15	ZS-201407	PAN23x03STL CMT			
	CHASIS MECHA SIDE (L) BLOCK				
1-16	BZ-T2030A110A	OIL CLUTCH BLK GX-F71			
1-17	ZW-270088	RING E 190SUP CMT			
	DETECTION P.C BOARD BLOCK				
1-18	ET-311977	PHOTO SENSOR SPI-201			
	SW LEAF BLOCK				
1-19	ES-336990	SW LEAF BSW-169 01-1 NO			
	REEL MOTOR BLOCK				
1-20	BM-T2030A120A	△ REEL MOTOR BLK GX-F71			
1-21	BM-B336989	△ REEL MOTOR (PULLEY) PART			
1-22x	EO-669273	COIL FIX 2 FL5R200 18μH			
	LEVER BRAKE (A) BLOCK				
1-23	BL-T2030A160A	LEVER BRAKE (A) BLK GX-F51			
1-24	TC-336146	BRAKE RUBBER			
	LEVER BRAKE (B) BLOCK				
1-25	BL-T2030A170A	LEVER BRAKE (B) BLK GX-F51			
	D LED BLOCK				
1-26	ED-337010	D LED SLF-201C GRN			
	MECHA BLOCK				
1-27	TC-336605	WIND IDLER ASSY			
1-28	ZG-336140	SP TORSION IDLER			
1-29	BR-336606	REEL TABLE ASSY			
1-30	BR-342719	REEL TABLE (B) ASSY			
1-31	ZG-336141	SP PUSH BT			
1-32	TC-336142	HOLDER BT SP			
1-33	ZW-330073	PW21x040x020			
1-34	MT-305793	REEL CAP			
1-35	BL-B336196	LEVER BT PART			
1-36	ZG-329444	SP T2-3.2/0.2-11.2 T2-040			
1-37	ZG-312946	SP T1-3.2/0.29-16.0 T1-062			
1-38	ZW-270088	RING E 190SUP CMT			
1-39	BL-B336150	ARM PINCH ROLLER (A) PART			
1-40	MP-336153	PINCH ROLLER (A)			
1-41	ZW-305546	PW21x040x025PSL			
1-42	ZW-356657	RING E 150SUP CMT			
1-43	ZG-336175	SP PULL PINCH ROLLER (T)			
1-44	ZG-321534	SP T2-3.2/0.29-12.5 T2-060			
1-45	ZW-336603	RING GRIP 28SSUP ACP			
1-46	ZW-306464	PW31x070x050STL CMT			
1-47	BL-B336202	ARM PINCH ROLLER (B) PART			
1-48	MP-336204	PINCH ROLLER (B)			
1-49	ZW-381644	PW21x040x013PSL			
1-50	HZ-336205	GUIDE TAPE (B)			
1-51	ZS-608095	PAN20x05STL CMT			
1-52	ZG-336206	SP TORSION RETURN			
1-53	ZW-618884	N20STL CMT 1			
1-54	ZG-336208	SP PULL PINCH ROLLER (S)			
1-55	MV-357208	BALL200STL			
1-56	ZG-336157	SP PLATE HEAD HOLD			
1-57	ZS-342002	ST PAN26x16STL CMT			
1-58	ML-336158	LEVER DETECTION (B)			

MOTOR BLOCK

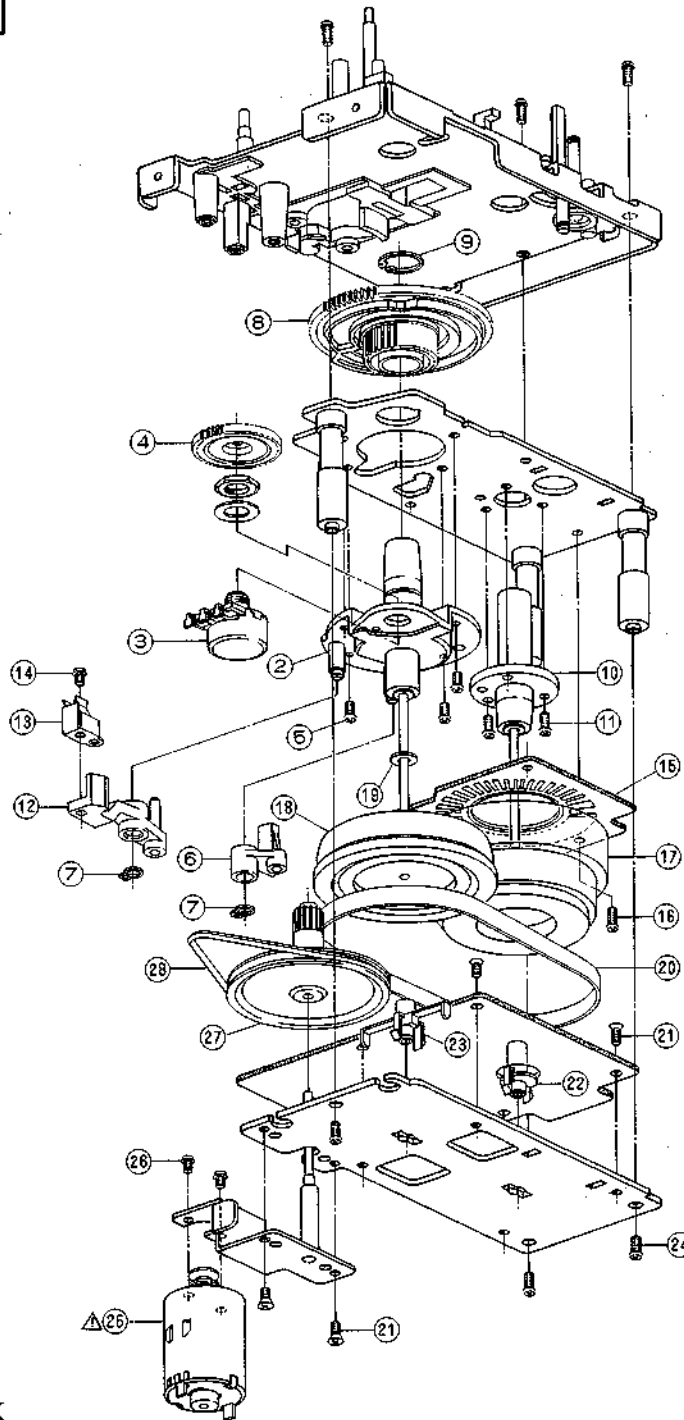

2. MOTOR BLOCK

REF. NO.	PARTS NO.	DESCRIPTION	REF. NO.	PARTS NO.	DESCRIPTION
2-1x	BM-M3104A010A	△ MOTOR BLM-310	2-16	ZS-479474	PAN26x05STL CMT
2-2	TC-B336004A	HOLDER CAPSTAN (C-1) PART	2-17	BF-B336024	FLYWHEEL (A) PART
2-3	EV-337052	VR ROTARY 16L10XOR B103	2-18	MI-336025	FLYWHEEL (B)
2-4	MZ-336005	GEAR POTENTION	2-19	ZW-309295	THRUST WASHER
2-5	ZS-432843	PAN26x04STL CMT	2-20	MB-336026	BELT CAPSTAN
2-6	BL-B336007	LEVER BRAKE CAM PART	2-21	ZS-477887	CTS26x05STL CMT
2-7	ZW-336603	RING GRIP 285SUP ACP	2-22	TC-336016	HOLDER THRUST (A)
2-8	MZ-336006	CAM WHEEL	2-23	TC-336027	HOLDER THRUST (B)
2-9	ZW-336604	RING S930SUP ACP	2-24	ZS-479474	PAN26x05STL CMT
2-10	TC-336002	HOLDER CAPSTAN (B)	2-25	BM-B337064	△ MOTOR OPERATION (PULLEY) PART
2-11	ZS-479474	PAN26x05STL CMT	2-26	ZS-477876	PAN20x03STL CMT
2-12	BL-B336009	LEVER EJECT CAM PART	2-27	MR-336019	PULLEY OPERATE
2-13	ZG-336011	SP PLATE CAM LEVER	2-28	MB-336021	BELT OPERATION
2-14	ZS-477876	PAN20x03STL CMT			
2-15	EA-336012	PC FG			

3. PRE AMP P.C BOARD BLOCK

REF. NO.	PARTS NO.	DESCRIPTION
3-1	BH-T2047A080A	PC PRE AMP BLK GX-7
PRE AMP P.C BOARD		
3-IC1	EI-337360	IC μ PC4082C
3-IC2	EI-337835	IC NE652
3-IC3	EI-337228	IC M5218L0
3-IC4	EI-322993	IC HD74107P
3-IC5	EI-337360	IC μ PC4082C
3-IC6	EI-337835	IC NE652
3-IC7,8	EI-337228	IC M5218L0
3-IC9	EI-336761	IC LA6458S
3-TR1to3	ET-639437	TR 2SC945L Q,P
3-TR4to8	ET-200505	TR 2SC2603 E,F
3-TR9,10	ET-321016	TR FET 2SK117 GR,BL
3-TR11,12	ET-639437	TR 2SC945L Q,P
3-TR13	ET-302296	TR 2SA952 K,L
3-TR14	ET-639437	TR 2SC945L Q,P
3-TR15	ET-554657	TR 2SA733A P,Q
3-TR16	ET-328868	TR 2SD1012-V G,H
3-TR17to22	ET-328578	TR 2SC2320 E,F
3-TR23,24	ET-639437	TR 2SC945L Q,P
3-TR25,26	ET-554657	TR 2SA733A P,Q
3-TR27to33	ET-639437	TR 2SC945L Q,P
3-TR34	ET-310148	Δ TR 2SD612K E,F
3-TR35to37	ET-200505	TR 2SC2603 E,F
3-TR38,39	ET-309353	TR 2SC2274K E,F
3-TR40	ET-341400	TR FET 2SK170 BL,GR
3-TR41	ET-338447	TR 2SA991 E,F
3-TR42	ET-308954	TR 2SC1844 E,F
3-TR43	ET-554657	Δ TR 2SA733A P,Q
3-TR44	ET-308954	TR 2SC1844 E,F
3-TR45	ET-639437	Δ TR 2SC945L Q,P
3-TR46	ET-639437	TR 2SC945L Q,P
3-TR47to50	ET-200505	TR 2SC2603 E,F
3-TR51to53	ET-639437	TR 2SC945L Q,P
3-TR54	ET-310148	Δ TR 2SD612K E,F
3-TR55	ET-639437	Δ TR 2SC945L Q,P
3-TR56	ET-200505	TR 2SC2603 E,F
3-TR57	ET-554657	TR 2SA733A P,Q
3-TR58	ET-639437	TR 2SC945L Q,P
3-TR59	ET-554657	TR 2SA733A P,Q
3-D1to7	ED-301911	D SILICON H DS448
3-D8	ED-344131	D ZENER H HZ11FA F10 A3
3-D9	ED-323979	D SILICON W03B F12 100/1.0A
3-D10to14	ED-301911	D SILICON H DS448
3-D15	ED-346433	D ZENER H HZ4FA F10 B2
3-D16,17	ED-301911	D SILICON H DS448
3-SW1	ES-337839	SE PUSH ESB-62694 5THROW
3-VR1	EV-337995	R S-FIX H RVF8P01 3P 103
3-VR2	EV-338588	R S-FIX H RVF8P01 3P 503
3-VR3	EV-330531	R S-FIX H TM8KV2-1S 3P 0.50W 503
3-VR4	EV-337995	R S-FIX H RVF8P01 3P 103
3-VR5	EV-345781	R S-FIX H RVF8P01 3P 202
3-VR6	ER-337861	R S-FIX H RVF8P01 3P 302
3-VR7	EV-337996	R S-FIX H RVF8P01 3P 104
3-T1	EO-337838	COIL OSC 1 32-5007-12 100KHz
3-FL1	ER-328491	FILTER DB D07-003K 100KHz
3-FL2	ER-328490	FILTER DB D07-001K 19KHz
3-FL3	EO-336738	COIL TUN 1 102AK-004 19.8KHz
3-FL4	EO-315758	COIL TUN 1 100S-431 100KHz
3-FL5	EO-346230	COIL VARI 1 RX-22MH 22mH
3-FL6	ER-328491	FILTER DB D07-003K 100KHz
3-FL7	EO-336738	COIL TUN 1 102AK-004 19.8KHz
3-R152	ER-338183	Δ R MF H 1/4W 104J
3-R154	ER-337863	Δ R MF H 1/4W 101J
3-R155	ER-337864	Δ R MF H 1/4W 822J
3-R156	ER-337865	Δ R MF H 1/4W 123J
3-R157	ER-337863	Δ R MF H 1/4W 101J
3-R159	ER-338183	Δ R MF H 1/4W 104J
3-R223	ER-238825	Δ R MF H 1/4W 682J
3-FR1,2	ER-200595	Δ R FUSE ERD2FC S10 1/4W 5R6J
3-C3	EC-300193	C EC V F05 NP SM 100M 16DC
3-C4	EC-332052	C EC V F05 NP SM 4R7M 35DC
3-C15	EC-333971	C EC V F05 NP SM 2R2M 50DC
3-C34	EC-300193	C EC V F05 NP SM 100M 16DC
3-C36	EC-347212	C MC F05 FM 270J 500DC
3-C38	EC-300193	C EC V F05 NP SM 100M 16DC

REF. NO.	PARTS NO.	DESCRIPTION
3-C40	EC-316150	C STY V F05 500 821J 50DC
3-C48	EC-310834	C MC V FM 680J 500DC
3-C56,57	EC-306419	C STY V F05 500 681J 50DC
3-C59	EC-310834	C MC V FM 680J 500DC
3-C65	EC-318313	C COMP V AWS 393J 50DC
3-C68	EC-321173	C STY V F05 500 181J 50DC
3-C71	EC-310834	C MC V FM 680J 500DC
3-C74	EC-347091	C MC V F05 FE92 10R0D 500DC
3-C94	EC-306419	C STY V F05 500 681J 50DC
3-C102	EC-300193	C EC V F05 NP SM 100M 16DC
3-C103	EC-332052	C EC V F05 NP SM 4R7M 35DC
3-C106	EC-306987	C STY V F05 500 471J 50DC
3-C110	EC-344110	C STY V S05 CQFS 911J 500DC
3-C111	EC-300193	C EC V F05 NP SM 100M 16DC
3-C116	EC-347189	C MC V F05 FM 100J 500DC
3-C119	EC-347197	C MC V F05 FM 150J 500DC
3-VR1	EV-337840	VR SLIDE 100P2WVOA A503
3-VR1	EV-337841	VR SLIDE 30P2SVOA B103

PHONE JACK P.C BOARD

3-J1 EJ-344761 PHONE J 3P JL3A 6.3

4. SYSCON P.C BOARD BLOCK

REF. NO.	PARTS NO.	DESCRIPTION
4-1	BA-T2047A090A	PC SYSCON BLK GX-7(U) (U)
4-1	BA-T2047A090B	PC SYSCON BLK GX-7(J) (J)
4-1	BA-T2047A090C	PC SYSCON BLK GX-7(C) (C,A)
4-1	BA-T2047A090D	PC SYSCON BLK GX-7(E) (E,V)
4-1	BA-T2047A090E	PC SYSCON BLK GX-7(B) (B,S)

SYSCON P.C BOARD

4-IC1	EI-337006	IC LM6402H-063
4-IC4,5	EI-337008	IC LC7800
4-IC6	EI-337009	IC LC4049B
4-IC7	EI-336761	IC LA6458S
4-IC8	EI-330352	IC BA6109
4-IC9	EI-336992	IC μ PC1043C
4-IC10	EI-337842	IC M5231L
4-TR1	ET-322598	Δ TR 2SB632K E,F
4-TR2,3	ET-310148	Δ TR 2SD612K E,F
4-TR5	ET-318239	Δ TR 2SD863 E,F
4-TR6,7	ET-310148	Δ TR 2SD612K E,F
4-TR8	ET-308976	TR 2SC1815 BL,GR
4-TR9	ET-200558	TR 2SA1115 E,F
4-TR10to16	ET-200505	TR 2SC2603 E,F
4-TR17to20	ET-336997	TR 2SB808-V G,H
4-TR21,22	ET-328868	TR 2SD1012-V G,H
4-TR23,24	ET-200505	TR 2SC2603 E,F
4-TR25	ET-554657	TR 2SA733A P,Q
4-TR26to30	ET-200505	TR 2SC2603 E,F
4-TR32	ET-639437	TR 2SC945L Q,P
4-TR33	ET-554657	TR 2SA733A P,Q
4-TR34	ET-200505	Δ TR 2SC2603 E,F
4-TR35to37	ET-200505	TR 2SC2603 E,F
4-D1	ED-322238	Δ D SILICON 1B4B41 100/1.0A
4-D2to5	ED-323979	Δ D SILICON W03B F12 100/1.0A
4-D6	ED-338403	D ZENER V HZ11B-1S1
4-D7	ED-337867	D ZENER V HZ6C-2S1
4-D9	ED-344763	D ZENER V HZ22-2S1
4-D10,11	ED-346264	D ZENER V HZ11LS1 F05 B2
4-D13	ED-344280	D SILICON HGMA-01-FY2 F05
4-D14	ED-337289	D ZENER V HZ5A-1S1
4-D15	ED-337021	D ZENER V HZ9A-1S1
4-D16to18	ED-344280	D SILICON HGMA-01-FY2 F05
4-D19	ED-323979	D SILICON W03B F12 100/1.0A
4-D20	ED-344280	D SILICON HGMA-01-FY2 F05
4-D21	ED-337259	D ZENER V HZ6A-3S1
4-D22to24	ED-344280	D SILICON HGMA-01-FY2 F05
4-D25	ED-323979	D SILICON W03B F12 100/1.0A

REF. NO.	PARTS NO.	DESCRIPTION
4-SW1	ES-3442 70	△ SW PUSH SDDL1P 01-1
4-VR1	EV-338588	R S-FIX H RVF8P01 3P 503
4-CR1	EC-338341	C COMP 05-0034
4-CR2	ER-337374	R COMP 01-0400
4-CR3	ER-337376	R COMP 01-0399
4-CR4	ER-337631	R COMP 01-0449
4-X1	EC-337017	OSC CE CSB800A 0.8MHz
4-R7	ER-325270	△ R OMF H FS 1W 272J
4-R17	ER-313699	△ R OMF H FS 2W 221J
4-FR2to4	ER-200972	△ R FUSE ERD2FC S10 1/4W 33R0G
4-C26	EC-347590	C COMP V AWS 273J 50DC
4-C38	EC-320548	△ C CE V F 103Z 250AC (U,J,C,A)
4-C38	EC-338411	△ C CE V FZ 103P 400AC (E,V,S,B)
4-J1	EJ-3442 82	DIN J TCS1891-01-1011 P 8P
4-SW2,3	ES-346260	SW PUSH SPH121A 2-02-02N

5. METER/OPERATE P.C BOARD BLOCK

REF. NO.	PARTS NO.	DESCRIPTION
5-1	BA-T2047A100A	PC METER BLK GX-7
5-IC1	EI-337845	IC BA6146 M
5-IC2to4	EI-337013	IC LB1290
5-TR1	ET-554657	TR 2SA733A P,Q
5-IN1	EM-337844	IND FL BG-131Z DOUBLE
5-SW1to12	ES-336780	SW TACT KHH10902

6. MOTOR P.C BOARD BLOCK

REF. NO.	PARTS NO.	DESCRIPTION
6-IC1,2	EI-201940	IC NJM4558S
6-IC3,4	EI-337568	HOLE ELEMENT DHD-H070
6-TR1	ET-337011	TR 2SC2274K D,E
6-TR2	ET-337012	TR 2SA984K D,E
6-TR3	ET-337011	TR 2SC2274K D,E
6-TR4	ET-337012	TR 2SA984K D,E
6-D5	ED-338561	D ZENER H HZ2FA F10 B2
6-VR1,2	EV-464253	R S-FIX V V8K1-1 3P 202

7. ASSEMBLY BLOCK

REF. NO.	PARTS NO.	DESCRIPTION
7-1	BT-337827	△ TRANS POWER T2047(U)
7-1	BT-337828	△ TRANS POWER T2047(J)
7-1	BT-337829	△ TRANS POWER T2047(A,C)
7-1	BT-337830	△ TRANS POWER T2047(E,V)
7-1	BT-337831	△ TRANS POWER T2047(B,S)
7-2	EW-374894	△ AC CORD 2 CORES VM-0129A J (U)
7-2	EW-524845	△ AC CORD 2 CORES VM1165B J (J)
7-2	EW-207742	△ AC CORD 2 CORES VM-0238 UC (C,A)
7-2	EW-347897	△ AC CORD 2 CORES VM0364 NR CEE V (E,V)
7-2	EW-347828	△ CORD NR BS 42/0.15x2 EV (B)
7-2	EW-347898	△ AC CORD 2 CORES VM-0436,NR AS (S)
7-3	SZ-631945	STRAIN RELIEF SR-4N-4
7-4	EF-306125	△ FUSE TSC A 250V 0.31A (F2)(U,J)
7-4	EF-306088	△ FUSE TSC 125V 0.31A (F2)(C,A)
7-4	EF-339906	△ FUSE SEMKO T 250V 0.25A (F2) (E,V,S,B)
7-5	EF-306949	△ FUSE TSC A 250V 1.25A (F3)(U,J)
7-5	EF-309392	△ FUSE TSC 125V 1.25A (F3)(C,A)
7-5	EF-623103	△ FUSE SEMKO T 250V 1A (F3) (E,V,S,B)
7-6	EF-306949	△ FUSE TSC A 250V 1.25A (F4)(U,J)
7-6	EF-309392	△ FUSE TSC 125V 1.25A (F4)(C,A)
7-6	EF-623103	△ FUSE SEMKO T 250V 1A (F4) (E,V,S,B)
7-7	EF-306125	△ FUSE TSC A 250V 0.31A (F5)(U,J)
7-7	EF-306088	△ FUSE TSC 125V 0.31A (F5)(C,A)
7-7	EF-339906	△ FUSE SEMKO T 250V 0.25A (F5) (E,V,S,B)
7-8	EF-330461	△ FUSE GGS A 250V 0.50A (F6)(C,A)
7-8	EF-300591	△ FUSE EAWK T 250V 0.50A (F6) (E,V,S,B)
7-9	SP-336190N	PANEL REAR GX-7(U) AS
7-9	SP-336190P	PANEL REAR GX-7(J) AS
7-9	SP-336190Q	PANEL REAR GX-7(C) AS
7-9	SP-336190R	PANEL REAR GX-7(A) AS
7-9	SP-336190S	PANEL REAR GX-7(E,V) AS
7-9	SP-336190T	PANEL REAR GX-7(B,S) AS
7-10	ZS-463353	T2BR30x08STL BNI
7-11	ZS-307944	PAN26x05STL BNI
7-12	ES-305733	△ SW SELECTOR HXW0131-260 01-4 (U)
7-13	ZS-463353	T2BR30x08STL BNI (U)
7-14x	ZW-302909	RV NYL30x035 BL
7-15	ZS-304021	ST BID40x12STL CMT
7-16	SA-343007	FOOT
7-17x	ZW-305013	RV POP32 (A)
7-18	ZS-463353	T2BR30x08STL BNI

ASSEMBLY BLOCK

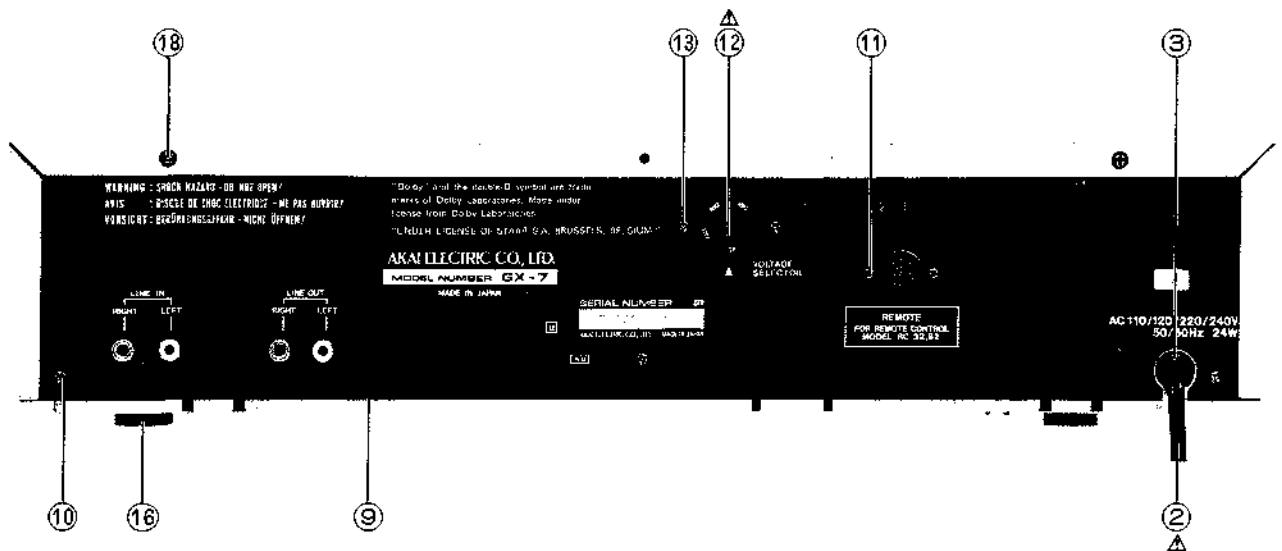
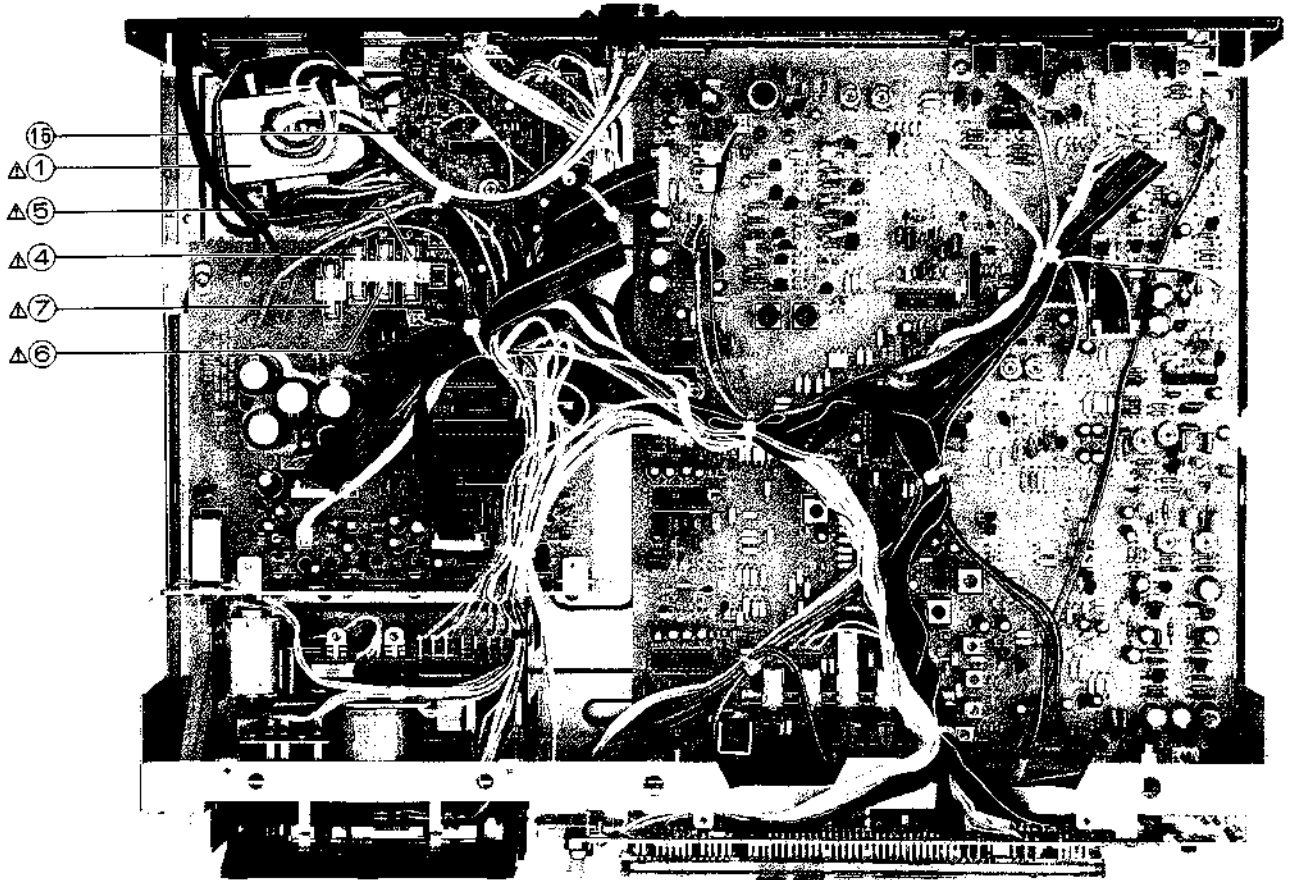

SECTION 3

SCHEMATIC DIAGRAM

- 1. SCHEMATIC DIAGRAM OF ICs 40
- 2. GX-7 No. 2-1 821224A POWER & SYSCON SCHEMATIC DIAGRAM... 49
- 3. GX-7 No. 2-2 821225A AMP SCHEMATIC DIAGRAM 50

BA6109

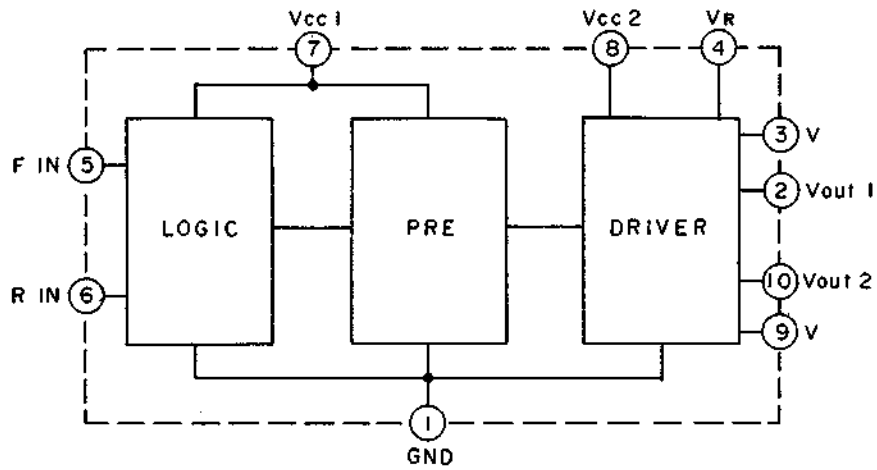

BA6146

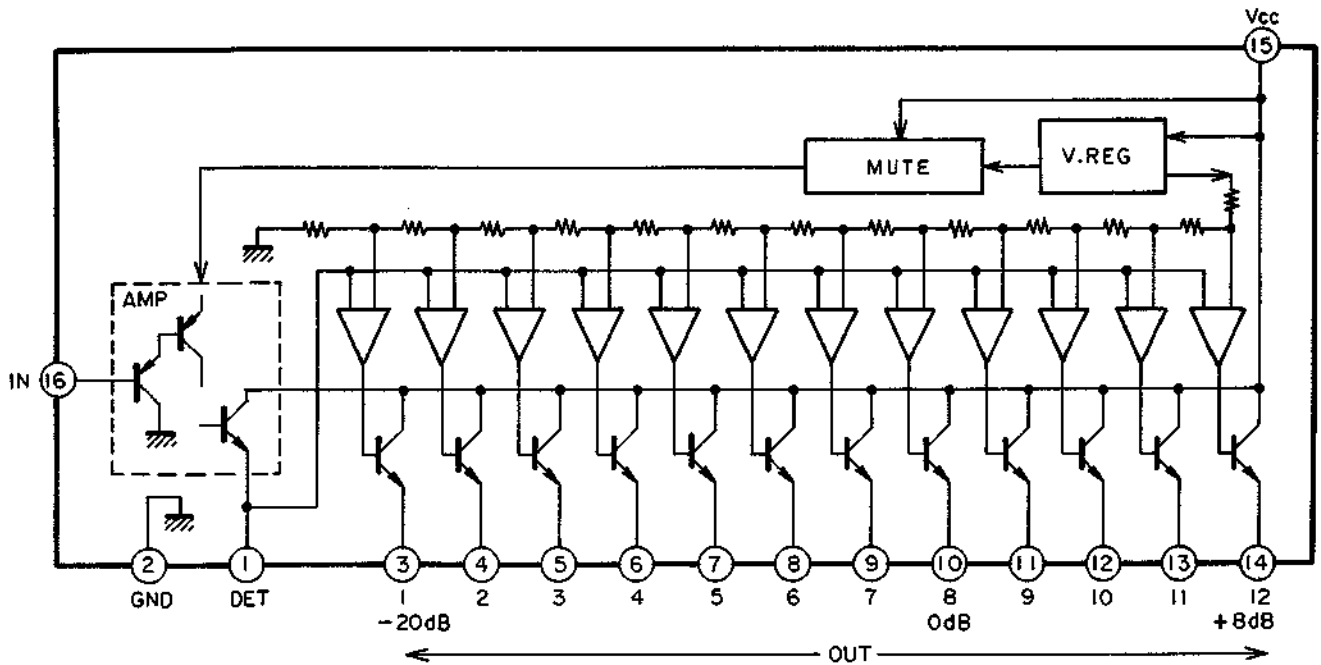

DHD-H070

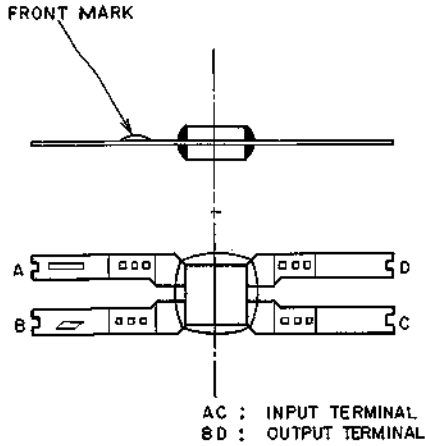

HD74107P

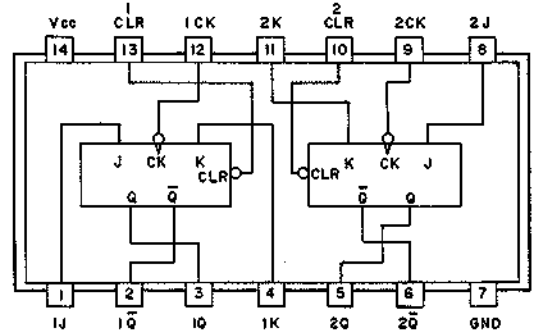

LA6458S, TA75558S

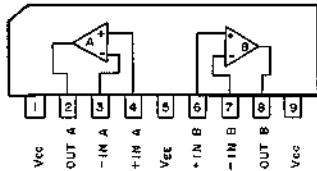

LC4049B

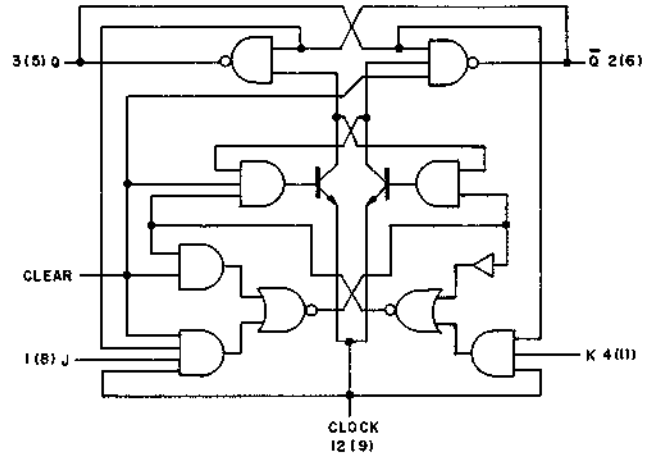
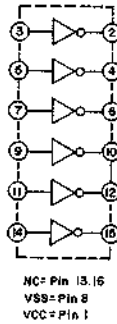

LB1290

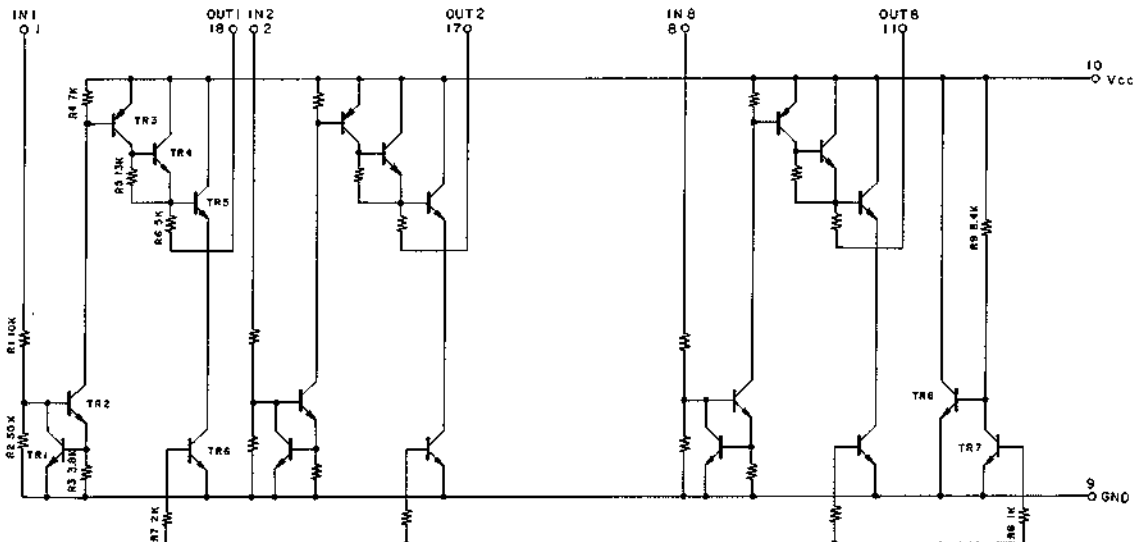
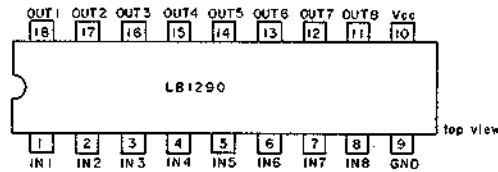

LC7800

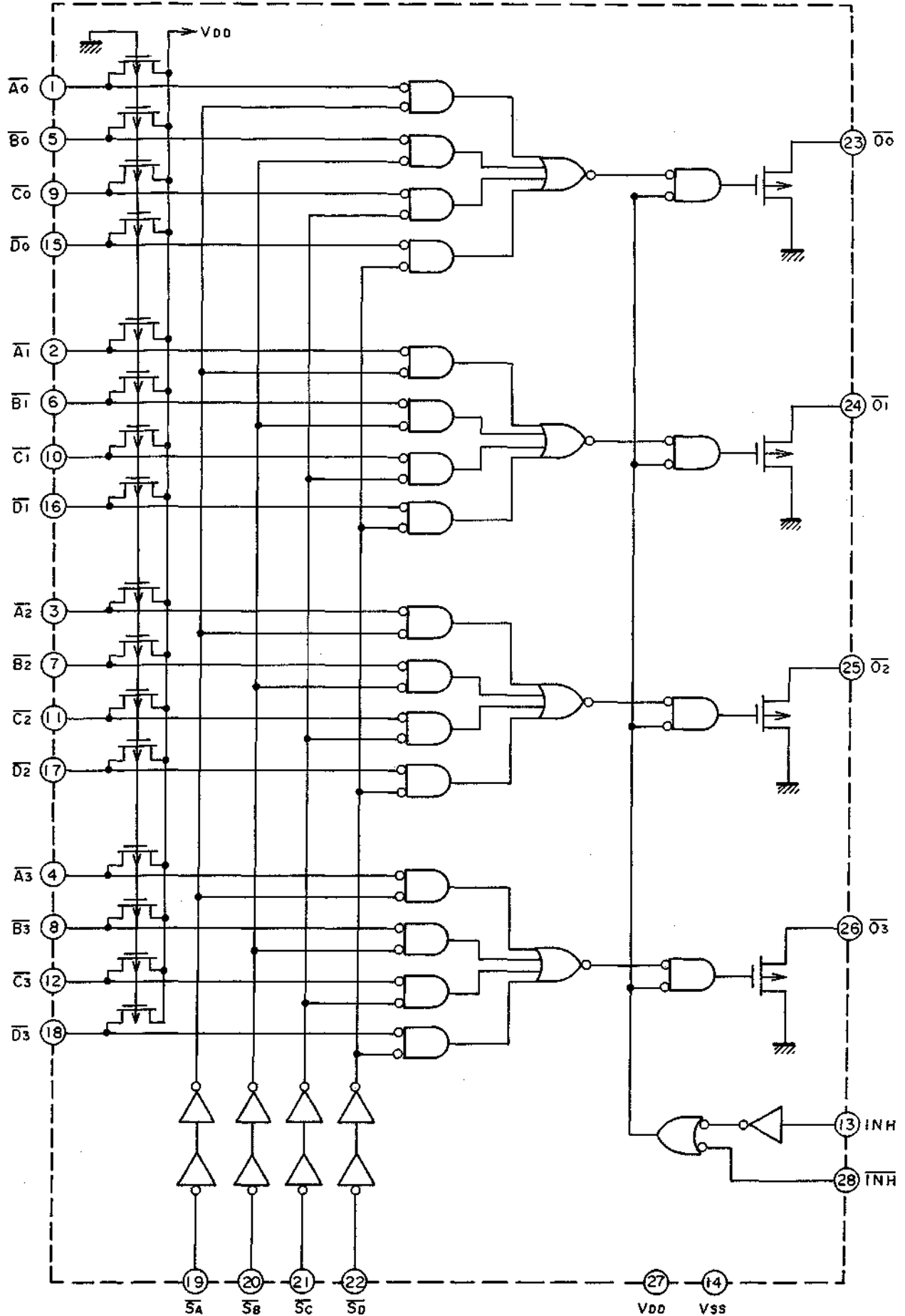

SCHEMATIC DIAGRAM GX-7

**CONNECTION OF EACH TERMINAL OF IC (LC 7800)
FOR EXPANDING IC (LM6402H-063) INPUT PORT**

PIN	Items connected to IC4	Items connected to IC5
1	PLAY SW	MEMORY SW
2	REC SW	1PLS SW
3	FF SW	OPEN ("H") (No connection)
4	REW SW	R114 of cam motor drive circuit
5	EJECT SW	TIMER PLAY SW
6	STOP SW	TIMER REC SW
7	NO CONNECTION	ANTIREC SW
8	AUTO MUTE SW	+5V (No connection)
9	REC CANCEL SW	+5V (No connection)
10	AUTO LOADING SW	+5V (No connection)
11	RESET SW	+5V (No connection)
12	TAPE/TIME SW	+5V (No connection)
13	GND	IC1 PIN2
14	GND	GND
15		C-stop signal of cam motor drive circuit
16	GND	GND
17	GND	GND
18	GND	GND
19		SYSCON IC1 PIN 40 (B3)
20		SYSCON IC1 PIN 39 (B2)
21		SYSCON IC1 PIN 38 (B1)
22		SYSCON IC1 PIN 37 (B0)
23		SYSCON IC1 PIN 33 (A0)
24		SYSCON IC1 PIN 34 (A1)
25		SYSCON IC1 PIN 35 (A2)
26		SYSCON IC1 PIN 36 (A3)
27	+5V	+5V
28	IC1 PIN 2	+5V

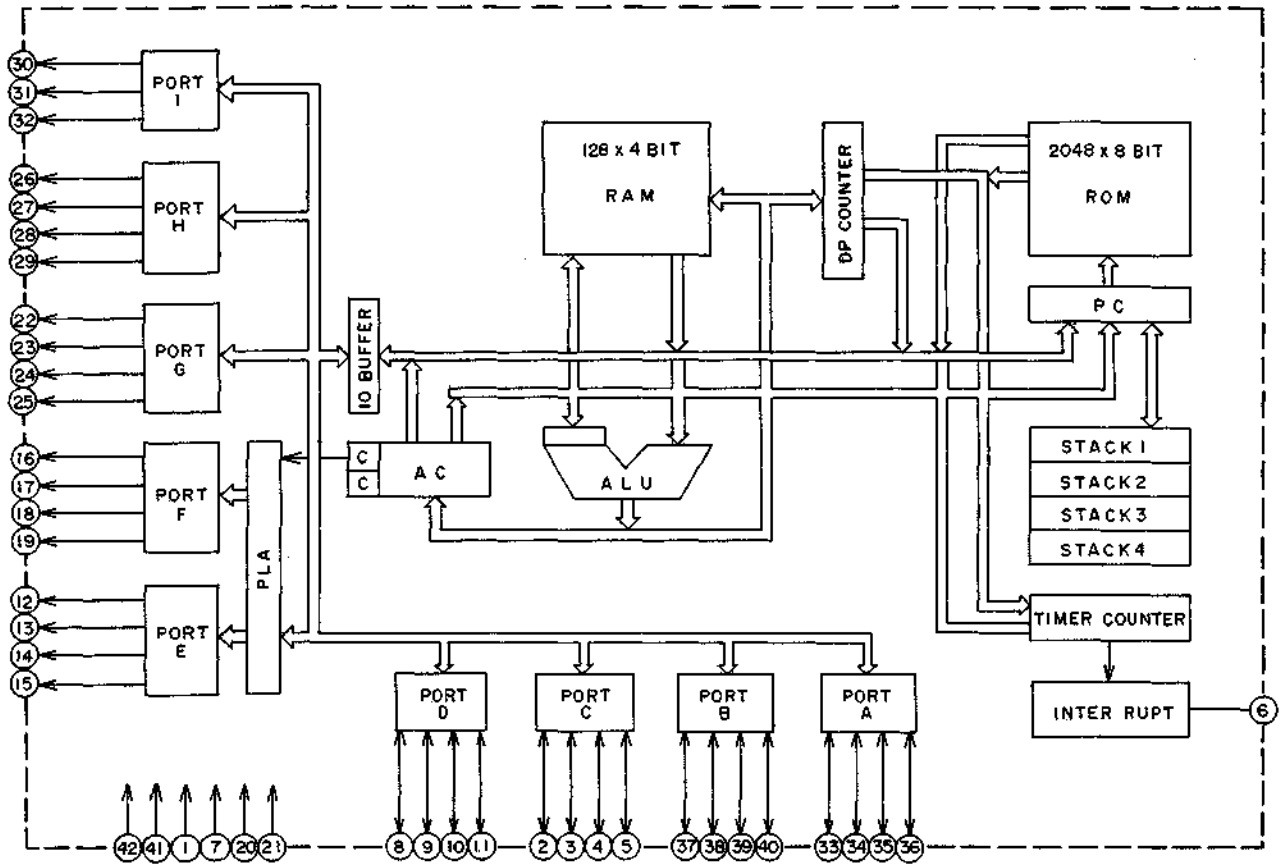

MEANING EACH TERMINAL OF CPU (LM6402 H063)

PIN NO.	SYMBOL	MEANING
1	XTAL	Input of crystal oscillator
2	C0	Input port selection strobe
3	C1	Colon, MIN/SEC is lit, turned on when level is "H".
4	C2	Between musics signal input. "H" while between musics.
5	C3	Tape pulse input
6	INT	Terminal for interruption. Power supply frequency input.
7	RES	Reset terminal. When power is on, reset when it is "L".
8	D0	No connection.
9	D1	BIAS OSC control terminal. Stop when it is "H".
10	D2	REC MUTE terminal. MUTE when it is "H".
11	D3	PB MUTE terminal. MUTE when it is "H".
12*	E0	Segment LED Drive a
13*	E1	Segment LED Drive b
14*	E2	Segment LED Drive c
15*	E3	Segment LED Drive d
16*	F0	Segment LED Drive e
17*	F1	Segment LED Drive f
18*	F2	Segment LED Drive g
19	F3	Strobe signal for driving function indication LED. Synchronized LED is lit. Refer to B0 ~ B3.
20	GND	Connect to ground
21	GND	Connect to ground
22	G0	Cam motor drive terminal. When played "H"
23	G1	Cam motor drive terminal. When stopped "H"
24	G2	Cam motor drive terminal. When searching "H" (when CUE)
25	G3	Cam motor drive terminal. When FAST "H" (when FF, REW)
26	H0	REEL M. reverse turn terminal. When REW "H". Prevents tape slackening.
27	H1	REEL M. normal turn terminal. When FF, PLAY "H".
28	H2	When PLAY "H". When REC "L".
29	H3	No connection
30	I0	Cam motor drive terminal. When EJECT "H".
31	I1	} No connection
32	I2	
33	A0	} Data input
34*	A1	
35*	A2	
36*	A3	
37*	B0	} Data selection strobe signal output. 4 digits drive
38*	B1	
39*	B2	
40*	B3	
41*	VCC	+5V
42	XTAL	Input of crystal oscillator

* Please refer to Fig. 12-1 for these terminals.

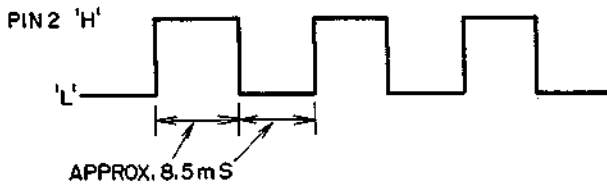

WHEN IT IS 'H', IC 5 IS SELECTED (SERCH)
 WHEN IT IS 'L', IC 4 IS SELECTED (SERCH)

PIN 26 WHEN POWER IS ON] SLACKENING PREVENTED
 (REW) WHEN LOADING

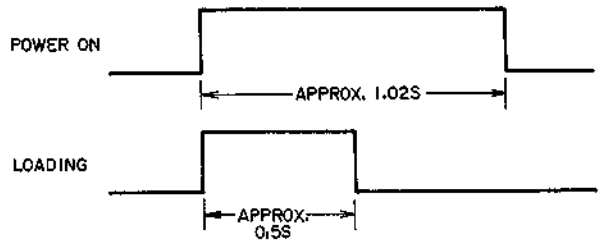

PIN 12 to 18 1 CYCLE → APPROX. 8 mS

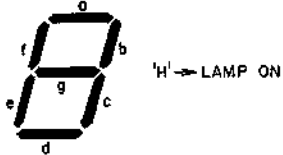
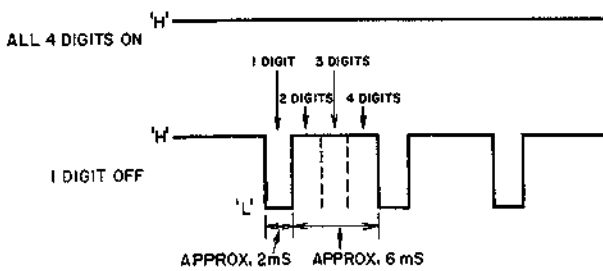

PIN 37 to 40 STROBE SIGNAL

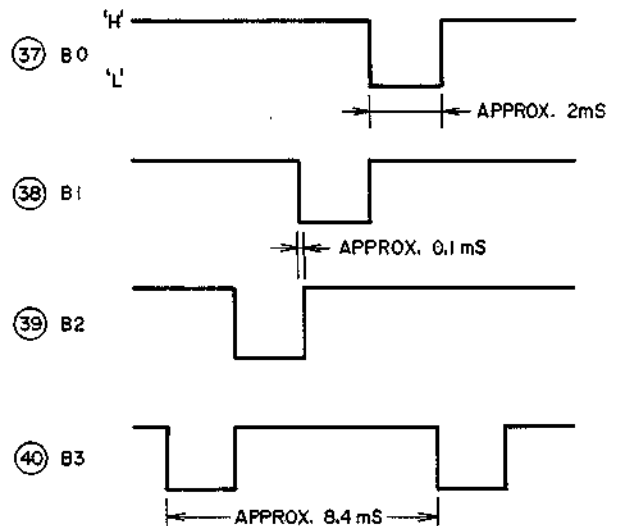

IC 4 23 IC 1 33 OTHERS +5V

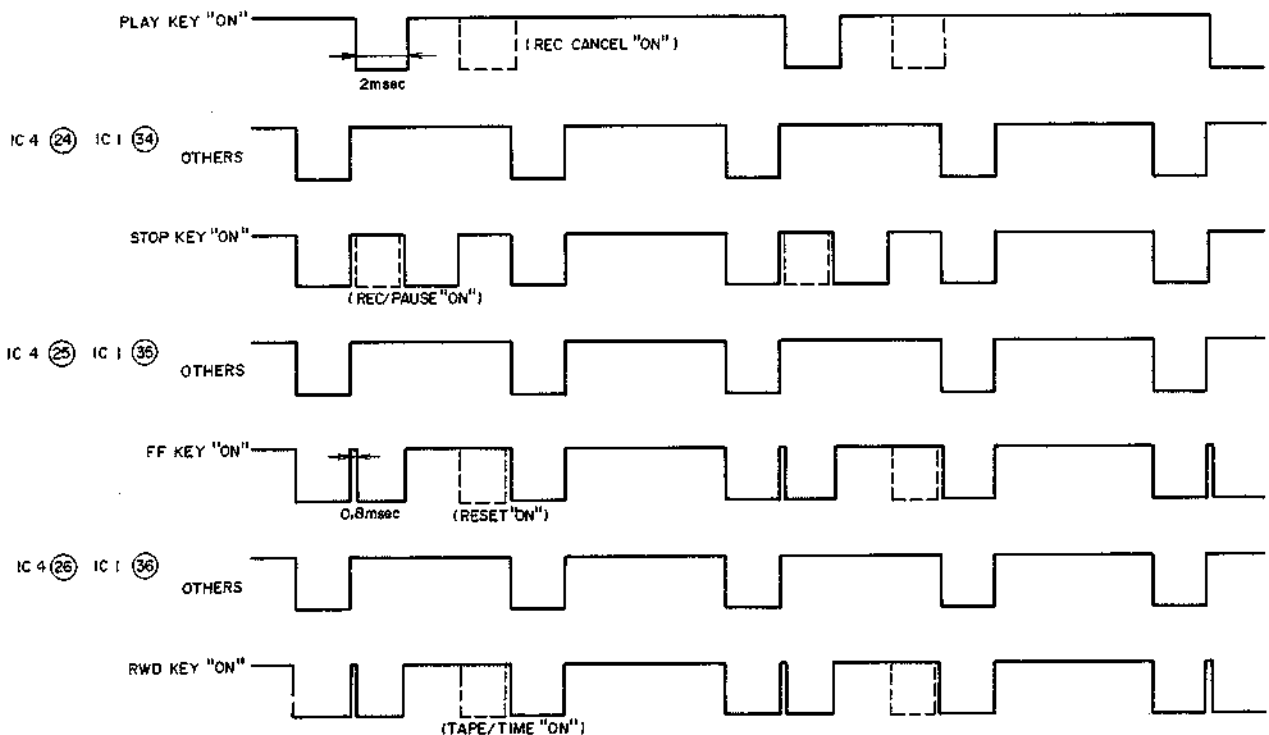

M5218LS

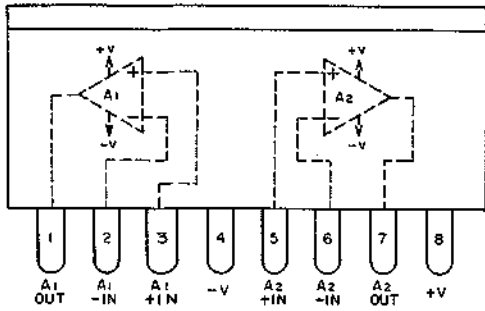

M5231L

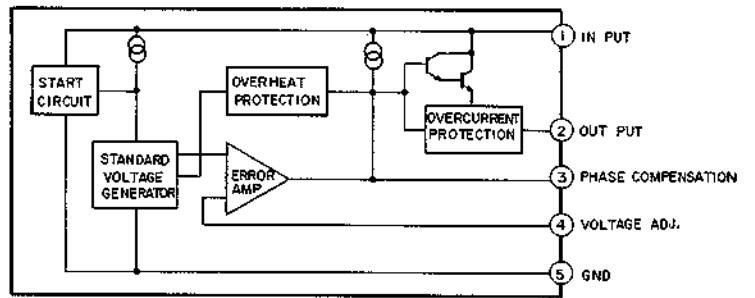

NE652

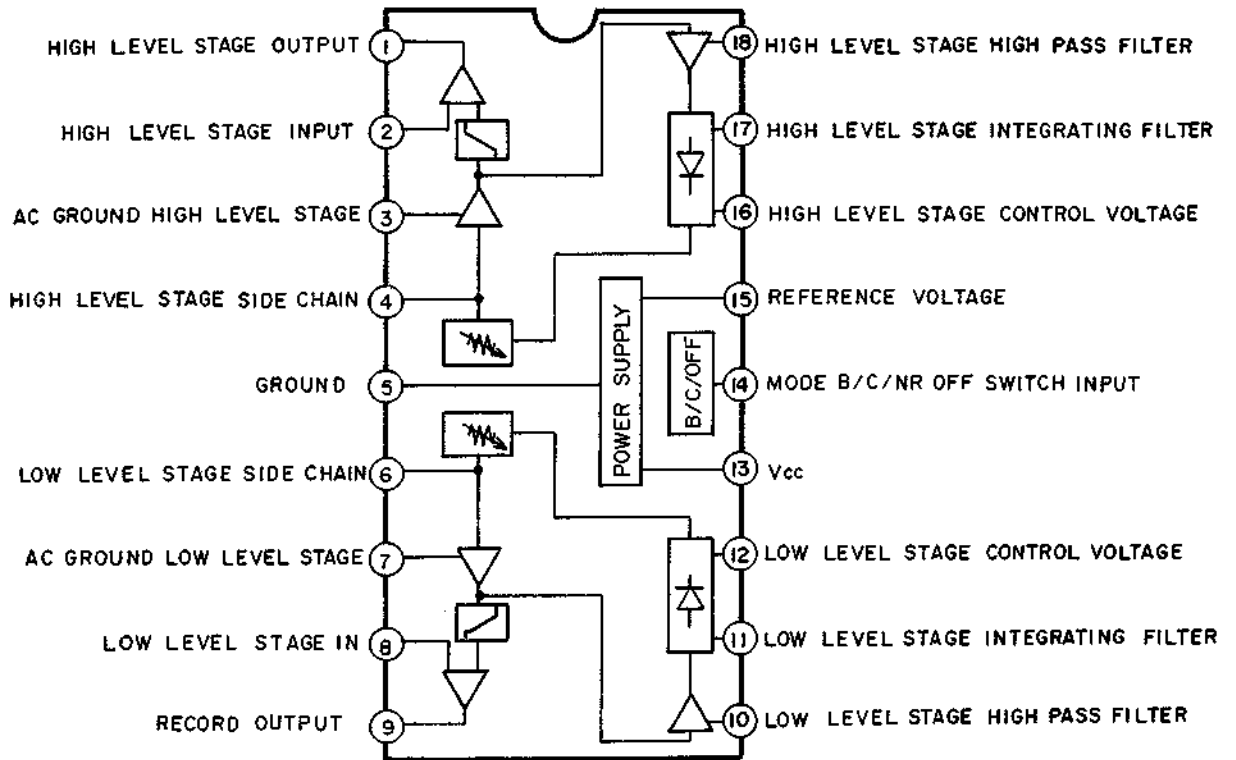

μPC1043

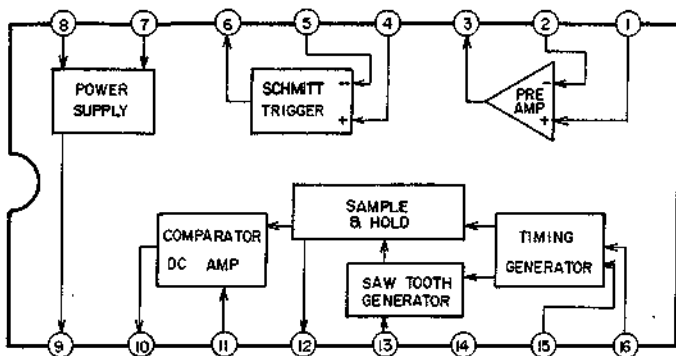

μPC4082C

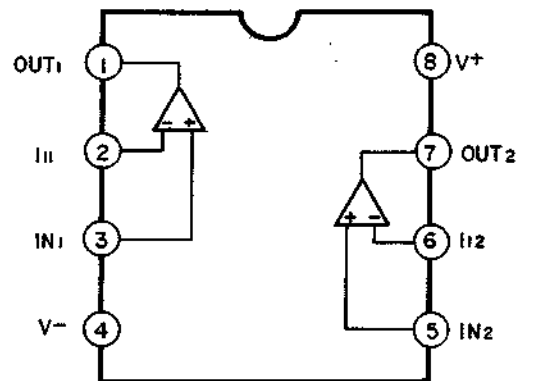

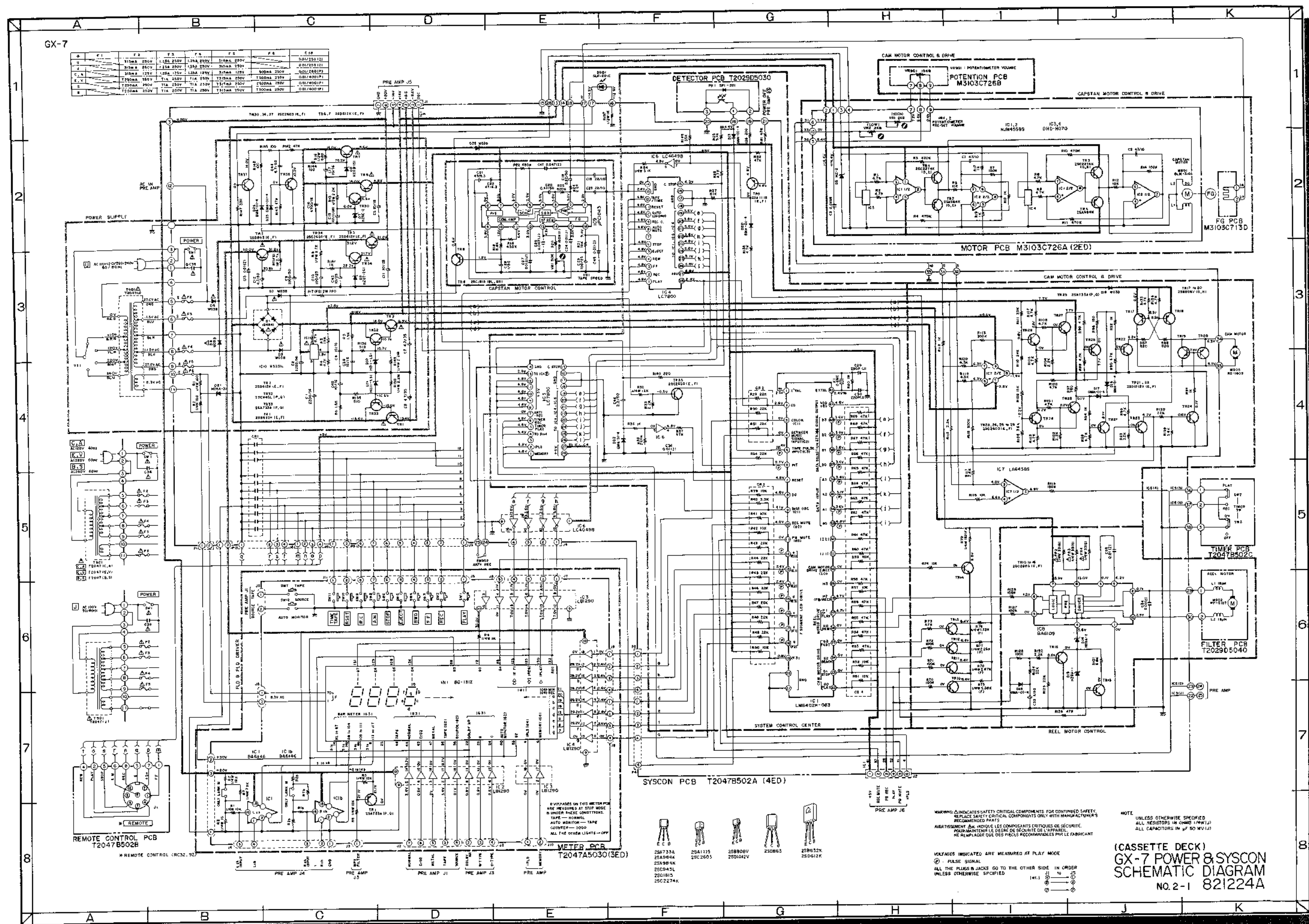

Q	Q1	Q2	Q3	Q4	Q5	Q6	Q7	Q8	Q9
1	2N156A	2N156A	2N156A	2N156A	2N156A	2N156A	2N156A	2N156A	2N156A
2	2N156A	2N156A	2N156A	2N156A	2N156A	2N156A	2N156A	2N156A	2N156A
3	2N156A	2N156A	2N156A	2N156A	2N156A	2N156A	2N156A	2N156A	2N156A
4	2N156A	2N156A	2N156A	2N156A	2N156A	2N156A	2N156A	2N156A	2N156A
5	2N156A	2N156A	2N156A	2N156A	2N156A	2N156A	2N156A	2N156A	2N156A
6	2N156A	2N156A	2N156A	2N156A	2N156A	2N156A	2N156A	2N156A	2N156A
7	2N156A	2N156A	2N156A	2N156A	2N156A	2N156A	2N156A	2N156A	2N156A
8	2N156A	2N156A	2N156A	2N156A	2N156A	2N156A	2N156A	2N156A	2N156A

WARNING: INDICATES SAFETY CRITICAL COMPONENTS FOR CONTINUED SAFETY. REPLACE SAFETY CRITICAL COMPONENTS ONLY WITH MANUFACTURER'S RECOMMENDED PARTS.
 AVERTISSEMENT: *K* INDIQUE LES COMPOSANTS CRITIQUES DE SECURITE. POUR MAINTENIR LE DEGRÉ DE SECURITE DE L'APPAREIL, NE REMPLACEZ QUE DES PIÈCES RECOMMANDÉES PAR LE FABRICANT.

NOTE: UNLESS OTHERWISE SPECIFIED, ALL RESISTORS IN OHMS (100K, 10M, 100M, 1000M) ALL CAPACITORS IN μF (50, 100, 1000, 10000).

(CASSETTE DECK)
 GX-7 POWER & SYSICON
 SCHEMATIC DIAGRAM
 NO. 2-1 821224A

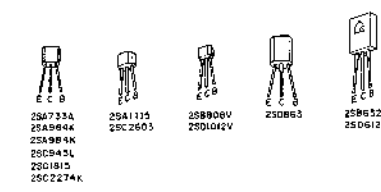

VOLTAGES INDICATED ARE MEASURED AT PLAY MODE.
 PULSE SIGNAL
 ALL THE PLUGS & JACKS GO TO THE OTHER SIDE IN ORDER UNLESS OTHERWISE SPECIFIED.

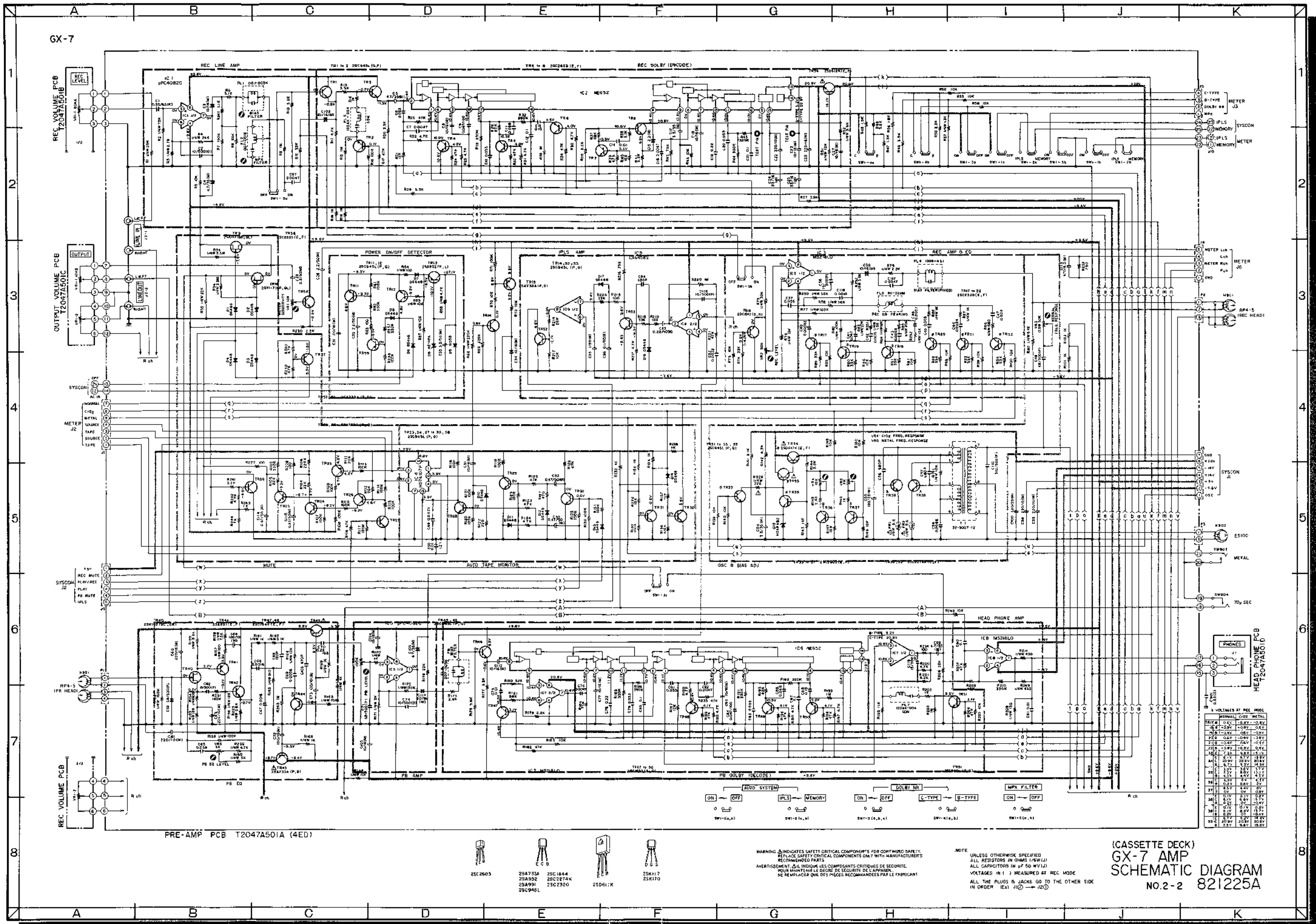

(CASSETTE DECK)
GX-7 AMP
 SCHEMATIC DIAGRAM
 NO.2-2 821225A