

AKAI SERVICE MANUAL

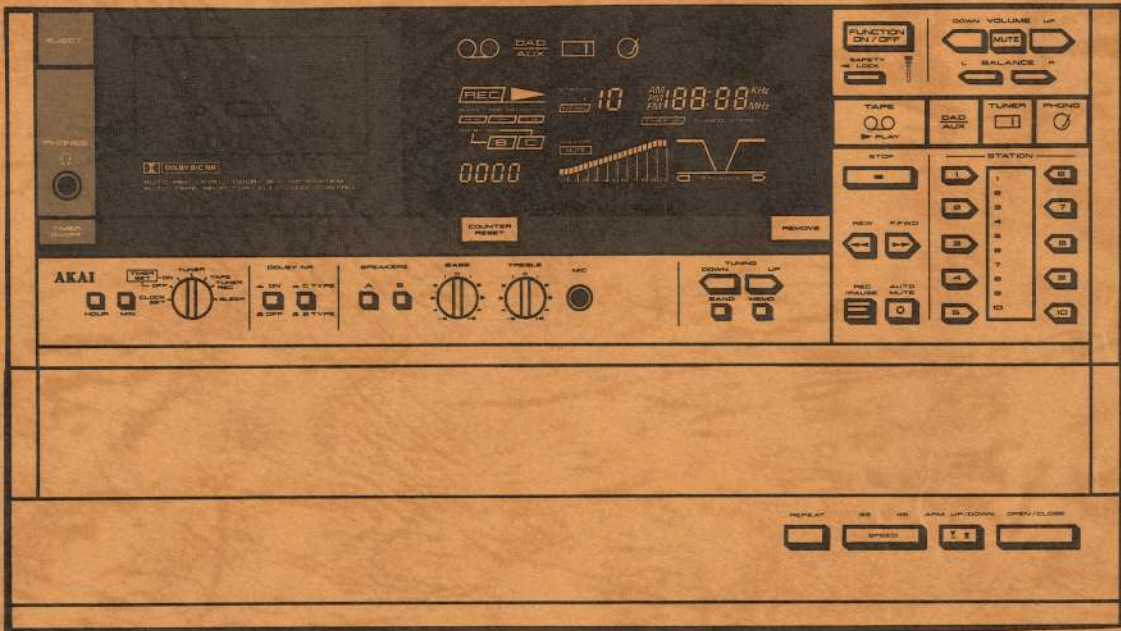

Hi-Fi COMPOSITE SYSTEM

MODEL F-3/L (FD-3/L, FP-3)

- Refer to F-1 (FD-1 + FP-3) Service Manual for the turntable model FP-3.
- This manual is also applicable for the model FD-3 in the composite system F-5/L
- Refer to F-7/L Service manual for the turntable model FP-7 in the composite system F-5/L.

ABBREVIATIONS FOR SERVICE MANUAL MODEL F-3/L (FD-3/L, FP-3)

ABBREVIATION	EXPLANATION
AC	ACcumulator
ALU	Arithmetic and Logic Unit
A.R	Anti Recording
CF	Carry Flag
CG	Clock Generator
CK	ClocK
COM	COMmon
CPU	Central Processing Unit
DC	Data Counter
F	Filament
FD	Frequency Divider
FLD	FLuorescent Display
GF	General Flag
"H"	High (Referring to voltage)
INH	INHibit
INT	INTerrupt
INTR	INTeRruption
IR	Instruction Register
"L"	Low (Referring to voltage)
MEMO	MEMOry
MIN	MINute
NC	No Connection
NP	No Pins
PC	Programme Counter
PLL	Phase Locked Loop
RAA	Random Access memory Address
RAM	Random Access Memory
ROM	Read Only Memory
S/C	Start/Cut
SCK	Serial Clock
SF	Status Flag
SPW	Stack Pointer Word
STB	STroBe
SI	Serial Input
SO	Serial Output
TC	Timer Counter
TG	Timing Generator
X IN	crystal INput
X OUT	crystal OUTput
ZF	Zero Flag



Hi-Fi COMPOSITE SYSTEM

MODEL F-3/L (FD-3/L, FP-3)

SECTION 1	SERVICE MANUAL	3
SECTION 2	PARTS LIST	31
SECTION 3	SCHEMATIC DIAGRAM	49

SAFETY INSTRUCTIONS

SAFETY CHECK AFTER SERVICING

Confirm the specified insulation resistance between power cord plug prongs and externally exposed parts of the set is greater than 10 Mohms, but for equipment with external antenna terminals (tuner, receiver, etc.) and is intended for **C** or **A**, specified insulation resistance should be more than 2.2 Mohms (ground terminals, microphone jacks, headphone jacks, line-in-out jacks etc.)

PRECAUTIONS DURING SERVICING

1. Parts identified by the **Δ** symbol parts are critical for safety. Replace only with parts number specified.
2. In addition to safety, other parts and assemblies are specified for conformance with such regulations as those applying to spurious radiation. These must also be replaced only with specified replacements. Examples: RF converters, tuner units, antenna selector switches, RF cables, noise blocking capacitors, noise blocking filters, etc.
3. Use specified internal wiring. Note especially:
 - 1) Wires covered with PVC tubing
 - 2) Double insulated wires
 - 3) High voltage leads
4. Use specified insulating materials for hazardous live parts. Note especially:
 - 1) Insulation Tape
 - 2) PVC tubing
 - 3) Spacers (Insulating Barriers)
 - 4) Insulation sheets for transistors
 - 5) Plastic screws for fixing microswitch (especially in turntable)
5. When replacing AC primary side components (transformers, power cords, noise blocking capacitors, etc.), wrap ends of wires securely about the terminals before soldering.

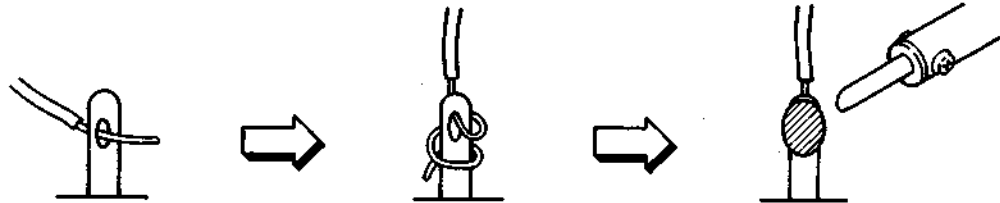

6. Observe that wires do not contact heat producing parts (heatsinks, oxide metal film resistors, fusible resistors, etc.).
7. Check that replaced wires do not contact sharp edged or pointed parts.
8. Also check areas surrounding repaired locations.
9. Use care that foreign objects (screws, solder droplets, etc.) do not remain inside the set.
10. Voltage conversion
Models for Canada, USA, Europe, UK and Australia are not equipped with this facility. Each machine is preset at the factory according to destination, but some machine can be set to 110V, 120V, 220V or 240V. If your machine's voltage can be converted:
 - 1) Disconnect the power cord.
 - 2) Move the VOLTAGE SELECTOR A and B located on the rear panel with a screwdriver until the correct voltage is indicated.

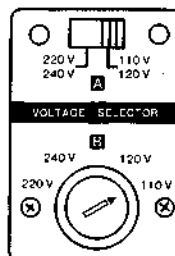

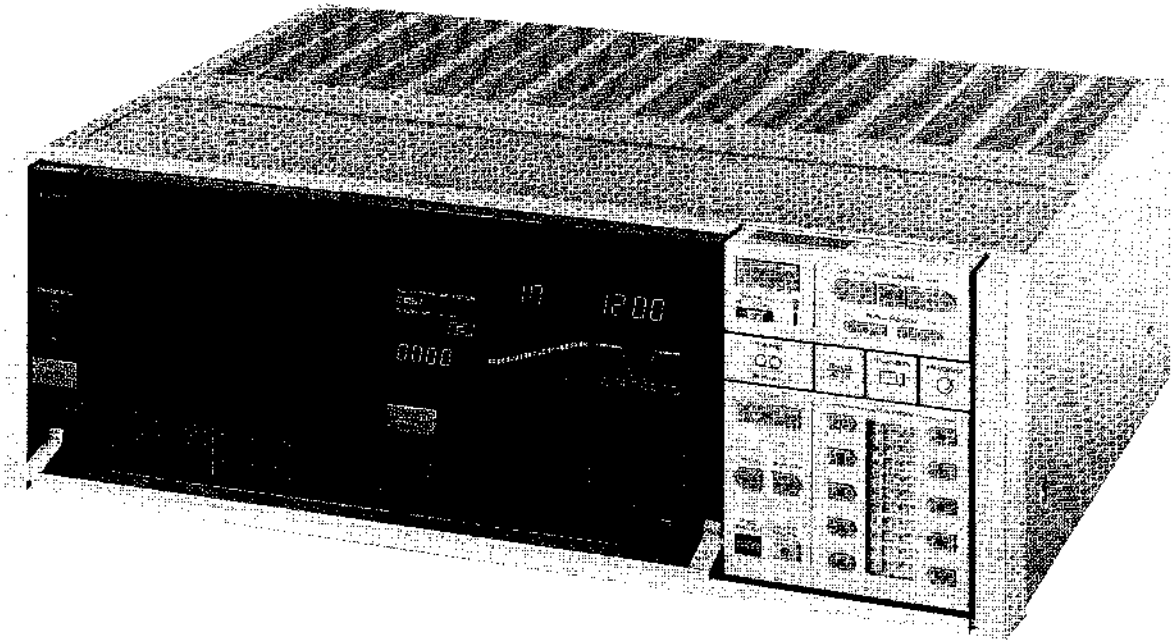

SECTION 1

SERVICE MANUAL
MODEL FD-3

TABLE OF CONTENTS

I. SPECIFICATIONS	4
II. DISMANTLING OF UNIT	5
III. CONTROLS	6
IV. PRINCIPAL PARTS LOCATION	8
V. MECHANICAL ADJUSTMENT (CASSETTE DECK SECTION)	9
5-1 PINCH ROLLER PRESSURE MEASUREMENT	9
5-2 TAKE-UP TORQUE AT VARIOUS MODES	9
5-3 TAPE SPEED ADJUSTMENT	9
5-4 REC/PB HEAD AZIMUTH ALIGNMENT	9
VI. ELECTRICAL ADJUSTMENT	10
6-1 PRE-AMPLIFIER ADJUSTMENT	10
6-2 TUNER ADJUSTMENT	12
VII. DC RESISTANCE OF VARIOUS COILS	15
VIII. CLASSIFICATION OF VARIOUS P.C BOARDS	16
8-1 P.C BOARD TITLES AND IDENTIFICATION NUMBERS	16
8-2 COMPOSITION OF VARIOUS P.C BOARDS	18

For basic adjustments, measuring methods, and operating principles, refer to GENERAL TECHNICAL MANUAL.

I. SPECIFICATIONS

AMPLIFIER SECTION

RATED POWER OUTPUT (2 channel driven)	30 W per channel, minimum RMS, at 8 ohms from 20 to 20,000 Hz with no more than 0.05% total harmonics distortion 35 W into 8 ohms at 1 kHz, with no more than 0.05% total harmonic distortion
MUSIC POWER	86 W per channel, at 8 ohms
INPUT SENSITIVITY	Phono: 2.5 mV/47 kohms AUX: 230 mV/47 kohms
OUTPUT	REC OUT: 150 mV SPEAKERS A or B $6\Omega \sim 16\Omega$, A + B $12\Omega \sim 16\Omega$

TUNER SECTION

FREQUENCY RANGES	FM 87.4 to 108.1 MHz AM 522 to 1,611 kHz (9k step) or 530 to 1,610 kHz (10k step)	L model FM 87.4 to 108.1 MHz MW 522 to 1,611 kHz LW 146 to 353 kHz
USABLE SENSITIVITY	FM (IHF) 11.2 dBf AM 300 $\mu\text{V/m}$	FM (IHF) 11.2 dBf MW 300 $\mu\text{V/m}$ LW 300 $\mu\text{V/m}$
SIGNAL TO NOISE RATIO	FM 75 dB (MONO)/65 dB (STEREO) AM 40 dB	FM 75 dB (MONO)/65 dB (STEREO) MW 40 dB LW 35 dB
STEREO SEPARATION	FM (1 kHz) 45 dB	FM (1 kHz) 45 dB
ANTENNAS	FM: EXT. ANT 75 ohms unbalanced AM: (MW/LW) Loop ANT.	

CASSETTE DECK SECTION

TRACK SYSTEM	4 track 2 channel stereo
MOTORS	Electronically speed controlled DC motor
FREQUENCY RESPONSE	Metal 30 to 17,000 Hz $\pm 3\text{dB}$ Chrome 30 to 16,000 Hz $\pm 3\text{dB}$ Normal 30 to 15,000 Hz $\pm 3\text{dB}$
SIGNAL TO NOISE RATIO	56 dB Dolby C type NR ON: Improves up to 15 dB at 500 Hz, 20 dB at 1 kHz to 10 kHz Dolby B type NR ON: Improves up to 5 dB at 1 kHz, 10 dB above 5 kHz
WOW AND FLUTTER	0.05% (WRMS), 0.09% (DIN 45500)
DISTORTION	0.8%
MIC INPUT	1.5 mV

HI-FI COMPOSITE SYSTEM F-3/L (FD-3/L & FP-3)

POWER CONSUMPTION	U Model: 135 W C, A Models: 180 W
POWER REQUIREMENTS	120 V 50 Hz for U.S.A. and Canada 220 V 50 Hz for European countries except U.K. 240 V 50 Hz for U.K. and Australia 110/120/220/240 V switchable, 50/60 Hz for other countries
DIMENSIONS	440(W) \times 250(H) \times 320(D) mm
WEIGHT	16.6 kg

WIRELESS REMOTE CONTROL (TRANSMITTER)

	Infrared Ray, PCM System
AREA OF OPERATION	7 m (on axis)
DIRECTIVITY	60° (on axis)
OPERATION TIME	10,000 times
POWER REQUIREMENT	DC 3V (R6 or AA size dry battery \times 2)
DIMENSIONS	100 \times 25 \times 131 mm
WEIGHT	150 g (without batteries)

* For improvement purposes, specifications and design are subject to change without notice.

* Noise reduction manufactured under license from Dolby Laboratories Licensing Corporation.

"Dolby" and the double-D symbol are trade marks of Dolby Laboratories Licensing Corporation.

II. DISMANTLING OF UNIT

In case of trouble, etc. necessitating dismantling, please dismantle in the order shown in the photographs. Reassemble in reverse order.

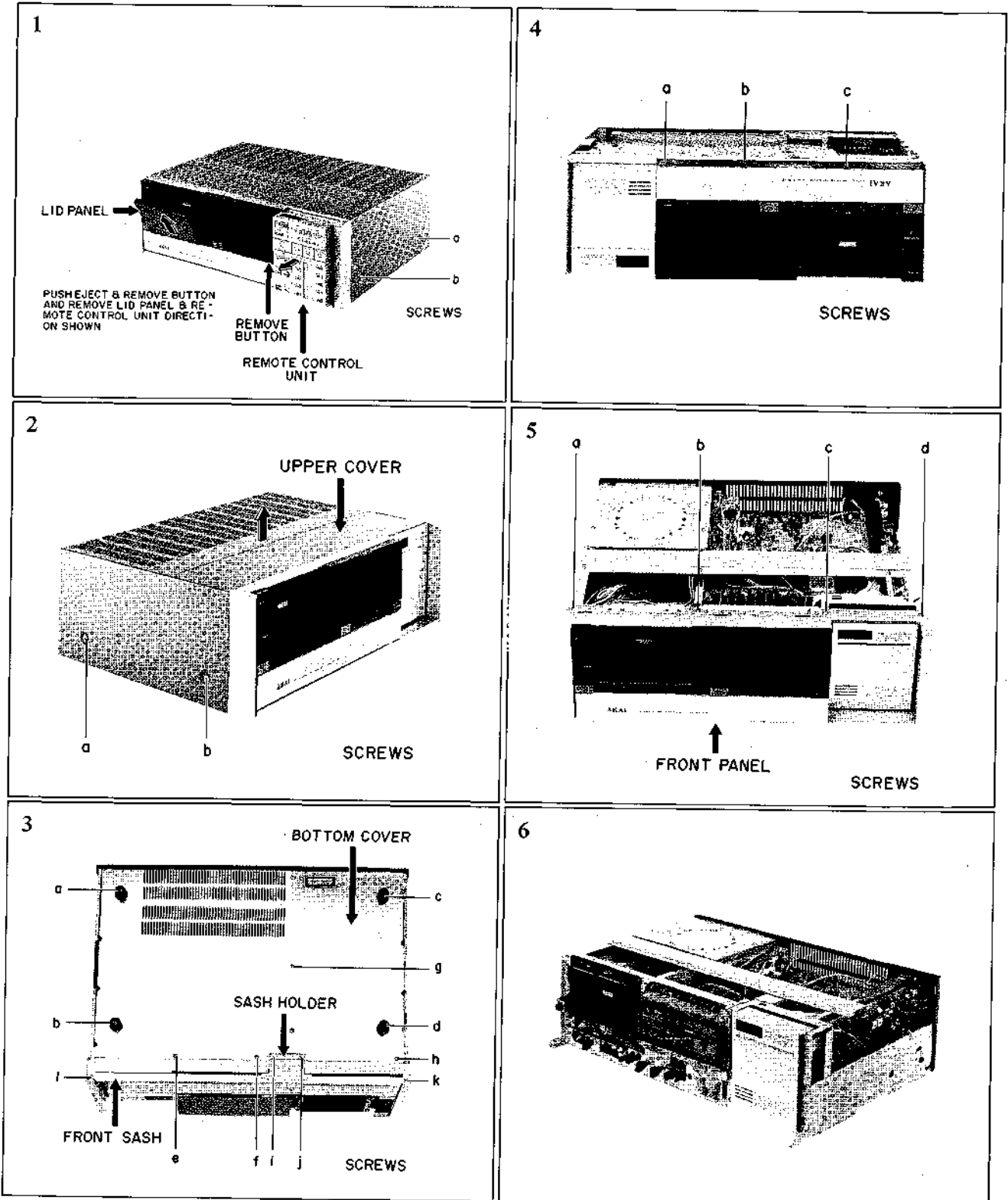

III. CONTROLS (Refer to Figs. 3-1 to 3-4)

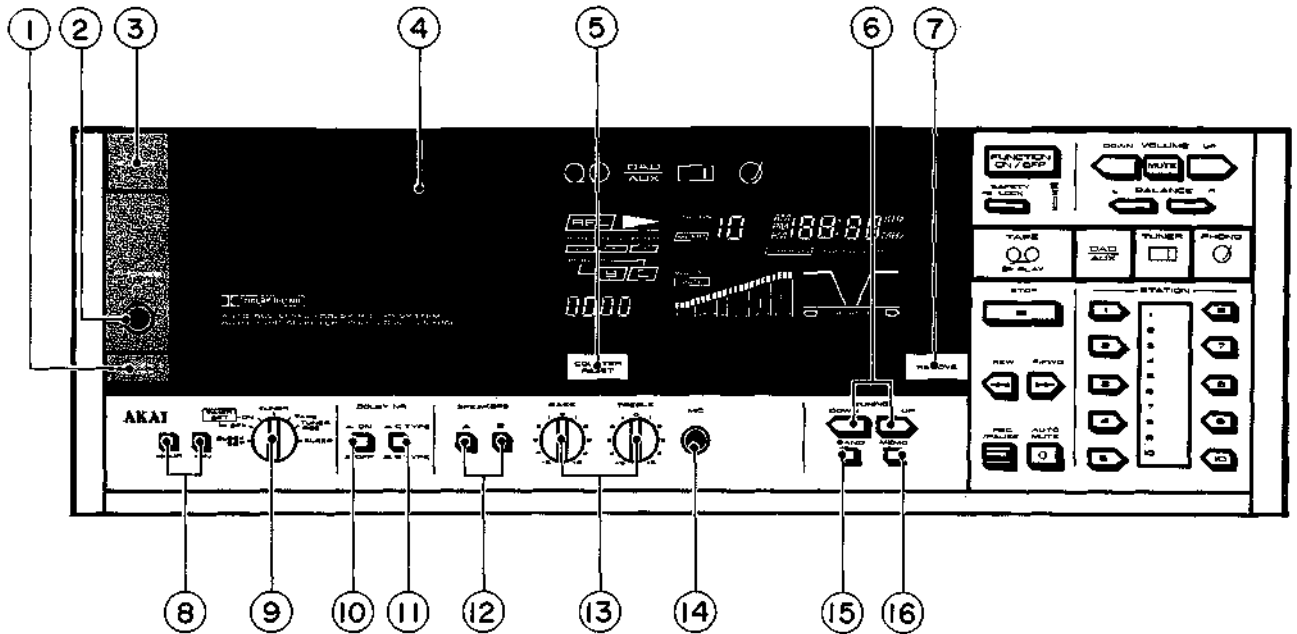

Fig. 3-1 Front View

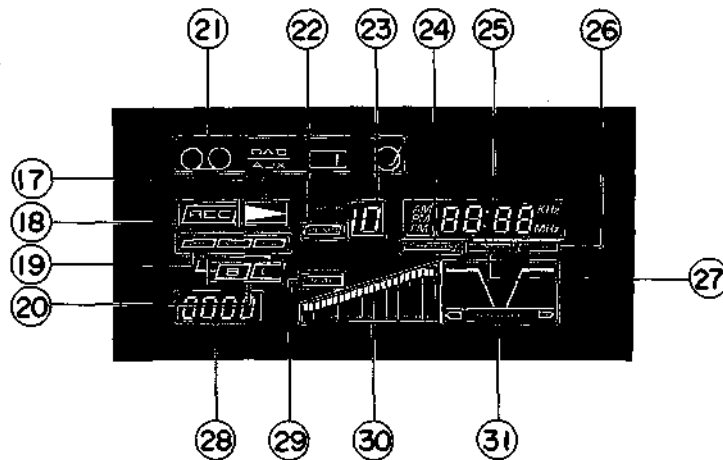

Fig. 3-2 Display

- | | |
|----------------------------------------|----------------------------------------|
| 1. TIMER ON/OFF SWITCH | 17. TAPE TRAVEL INDICATOR |
| 2. PHONES JACK | 18. REC INDICATOR |
| 3. EJECT BUTTON | 19. TAPE POSITION INDICATORS |
| 4. CASSETTE HOLDER | 20. DOLBY NR INDICATORS |
| 5. COUNTER RESET BUTTON | 21. INPUT SELECTOR INDICATORS |
| 6. TUNING (UP/DOWN) BUTTONS | 22. MEMO INDICATOR |
| 7. REMOVE BUTTON | 23. PRESET STATION INDICATORS |
| 8. TIMER ADJUSTMENT (HOUR/MIN) BUTTONS | 24. TIMER ON INDICATOR |
| 9. TIMER MODE SELECTOR | 25. TIME and TUNER FREQUENCY INDICATOR |
| 10. DOLBY ON/OFF SWITCH | 26. STEREO INDICATOR |
| 11. DOLBY B/C SWITCH | 27. TUNED INDICATOR |
| 12. SPEAKERS ON/OFF (A/B) BUTTONS | 28. TAPE COUNTER |
| 13. TONE CONTROLS (BASS/TREBLE) | 29. MUTE INDICATOR |
| 14. MICROPHONE JACK | 30. VOLUME INDICATOR |
| 15. BAND SELECTOR BUTTON | 31. BALANCE INDICATOR |
| 16. TUNING MEMO BUTTON | |

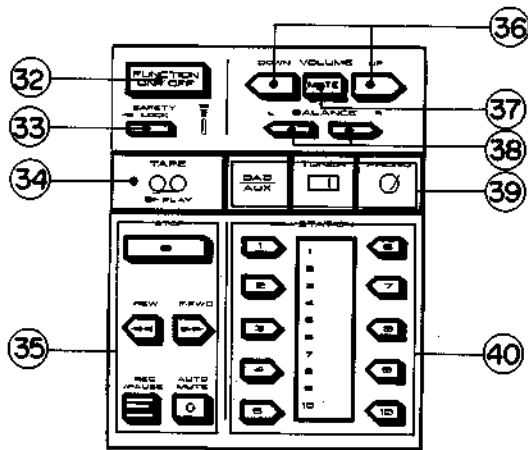

Fig. 3-3 Remote Control Unit

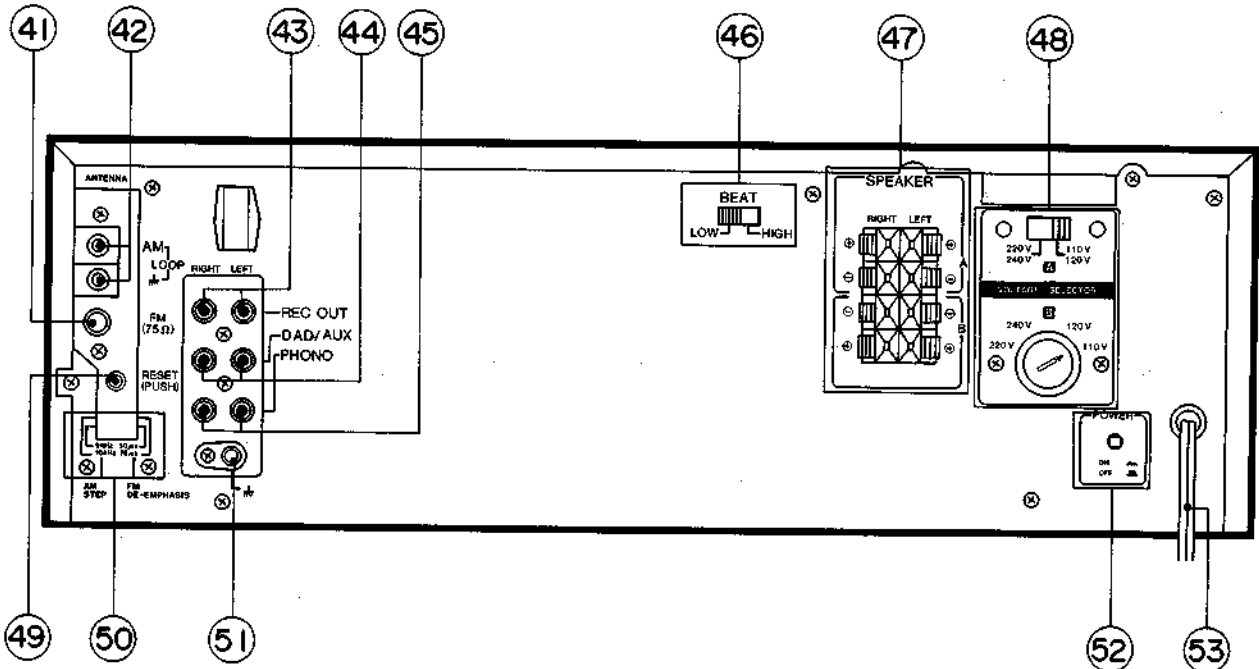

Fig. 3-4 Rear View

- | | |
|--------------------------------------|------------------------------------------|
| 32. FUNCTION SWITCH | 41. FM ANTENNA TERMINAL |
| 33. SAFETY LOCK SWITCH | 42. AM ANTENNA TERMINALS |
| 34. TAPE PLAY BUTTON | 43. REC OUT JACKS |
| 35. TAPE OPERATION BUTTON | 44. DAD/AUX JACKS |
| 36. VOLUME CONTROL (UP/DOWN) BUTTONS | 45. PHONO JACKS |
| 37. MUTE BUTTON | 46. BEAT CANCEL SWITCH |
| 38. BALANCE CONTROL (L/R) BUTTONS | 47. SPEAKER TERMINALS |
| 39. INPUT SELECTOR BUTTONS | 48. VOLTAGE SELECTOR (A/B): U MODEL ONLY |
| 40. PRESET STATION BUTTONS (1 to 10) | 49. PRESET BUTTON |
| | 50. AM STEP/FM DE-EMPHASIS SELECTOR |
| | 51. GROUND TERMINAL |
| | 52. POWER SWITCH |
| | 53. AC POWER CORD |

IV. PRINCIPAL PARTS LOCATION (Refer to Figs.4-1, 4-2)

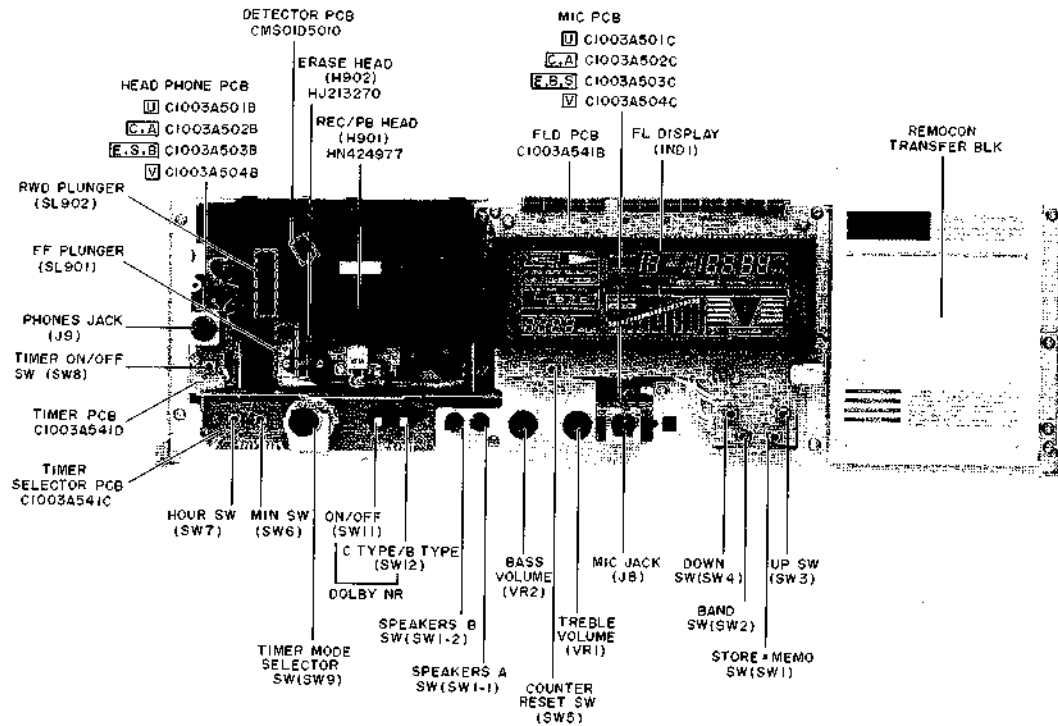

Fig. 4-1 Front View

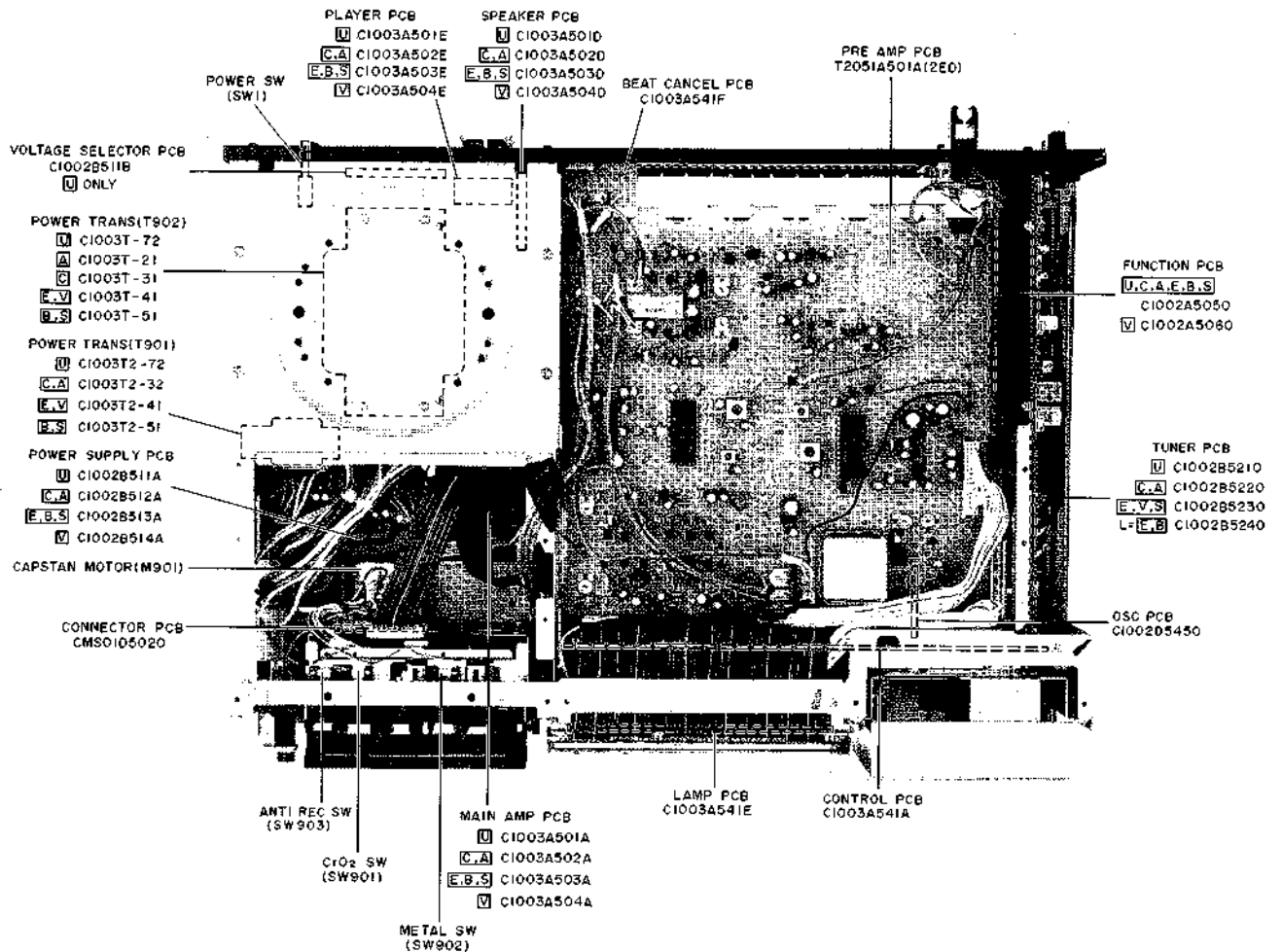

Fig. 4-2 Top View

V. MECHANICAL ADJUSTMENT (CASSETTE DECK SECTION)

5-1 PINCH ROLLER PRESSURE MEASUREMENT (Refer to Fig. 5-1)

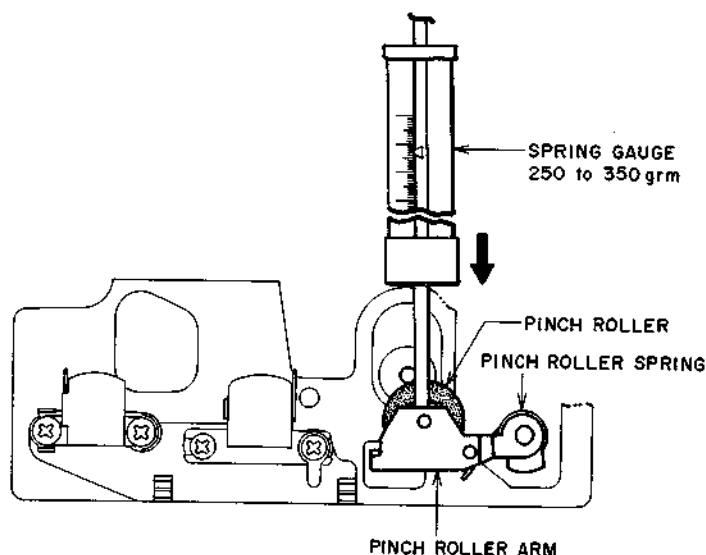

Fig. 5-1

Put in Play mode. Push pinch roller arm down with the spring gauge so that the pinch roller is 1 to 2 mm away from the capstan shaft and release slowly. Read the spring gauge at the moment the pinch roller

touches the capstan and begins to rotate. Specified pinch roller pressure is 250 to 350 grams. If the correct measurement is not obtained, replace the pinch roller spring.

5-2 TAPE-UP TORQUE AT VARIOUS MODES

Use a Cassette Torque Meter (AJ-751179) to confirm the following torque values at each mode.

- Play mode: 20 to 60 g-cm (Take-up Torque)
- 2 to 5 g-cm (Back Tension Torque)
- FF/RWD mode: 70 to 110 g-cm (Winding Torque)

5-3 TAPE SPEED ADJUSTMENT (Refer to Fig. 5-2)

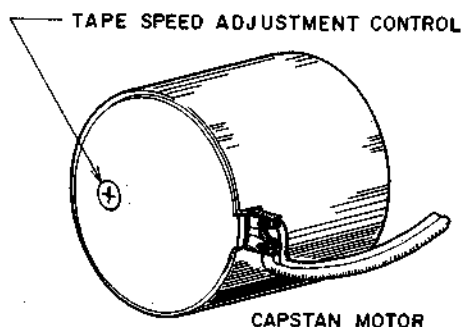

Fig. 5-2 Tape Speed Adjustment

Connect a frequency counter to Line Output terminal. Playback a 1,000 Hz pre-recorded Test Tape (AT-750744) or 3,150 Hz pre-recorded Test Tape (AT-751263), and adjust the Tape Speed Adjustment Variable Resistor to obtain a tape speed of 1,000 Hz \pm 1% or 3,150 Hz \pm 1%.

5-4 REC/PB HEAD AZIMUTH AUGNMENT (Refer to Fig. 5-3)

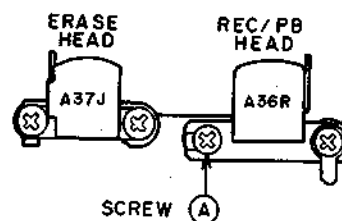

Fig. 5-3 Top View of the Heads

Playback a 10 kHz Azimuth Alignment Tape (AT-750778) and adjust the screw (A) to obtain the maximum output levels on both channels. Paint-lock the screw (A) after this adjustment.

- NOTES:
1. Be sure to clean the heads prior to this adjustment.
 2. Be careful not to use a magnetized driver or other magnetized tools in the vicinity of head area.
 3. Be sure to demagnetize the heads before and after the adjustment.

VI. ELECTRICAL ADJUSTMENT

6-1 PRE-AMPLIFIER ADJUSTMENT (Refer to Fig. 6-1)

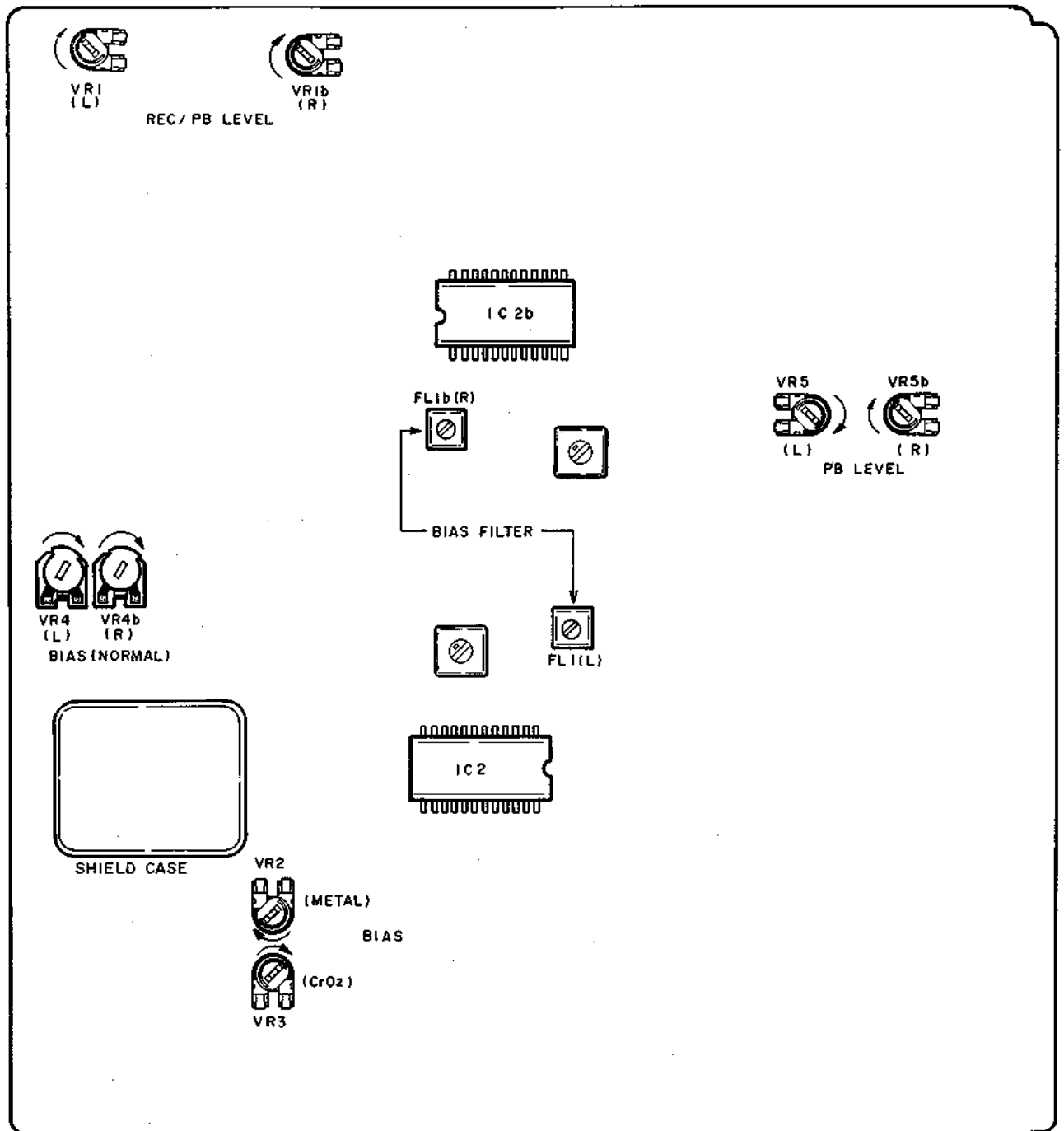

FRONT SIDE

PRE AMP PCB T205IA501A (2ED)

Fig. 6-1 Pre-Amplifier Adjustment Points

Step	Adjustment Item	Test Tape Supply Signal	Mode	Adjustment Point	Result	Remarks
1	Play Back level	315 Hz or 333 Hz	P.B	VR5	(315 Hz) -5.5 ±0.2 dBm or (333 Hz) -6.1 ±0.2 dBm	*See Note 1.
2	NORMAL Position Frequency Response	Normal Blank Tape 1,000 Hz, 10,000 Hz -25.5 dBm Recording	REC/P.B	VR4	1,000 Hz and 10,000 Hz levels are within ±0.5 dB	*See Note 2.
3	CrO ₂ Position Frequency Response	CrO ₂ Blank Tape 1,000 Hz, 10,000 Hz -25.5 dBm Recording	REC/P.B	VR3	1,000 Hz and 10,000 Hz levels are within ±0.5 dB	*See Note 2.
4	METAL Position Frequency Response	Metal Blank Tape 1,000 Hz, 10,000 Hz -25.5 dBm Recording	REC/P.B	VR2	1,000 Hz and 10,000 Hz levels are within ±0.5 dB	*See Note 2.
5	Recording level	Normal Blank Tape 1,000 Hz, -5.5 dBm Recording	REC/P.B	VR1	-5.5 ±0.3 dBm (410 mV)	*See Note 2.
6	Bias Filter	METAL Blank Tape No Signal input	REC PAUSE	FL1	AC Voltmeter Indicates minimum	

NOTE 1: As the test tape has been changed, set to -6.1 ± 0.2 dBm when using 333 Hz test tape. For details, refer to Service Guide (No. 0012) issued in Nov., 1982.

NOTE 2: Use the following cassette measuring tapes.

Normal tape : Maxell UD C-60

CrO₂ tape : TDK SA C-60

Metal tape : TDK MA C-60

6-2 TUNER ADJUSTMENT

6-2-1 TUNER P.C BOARD ADJUSTMENT POINTS

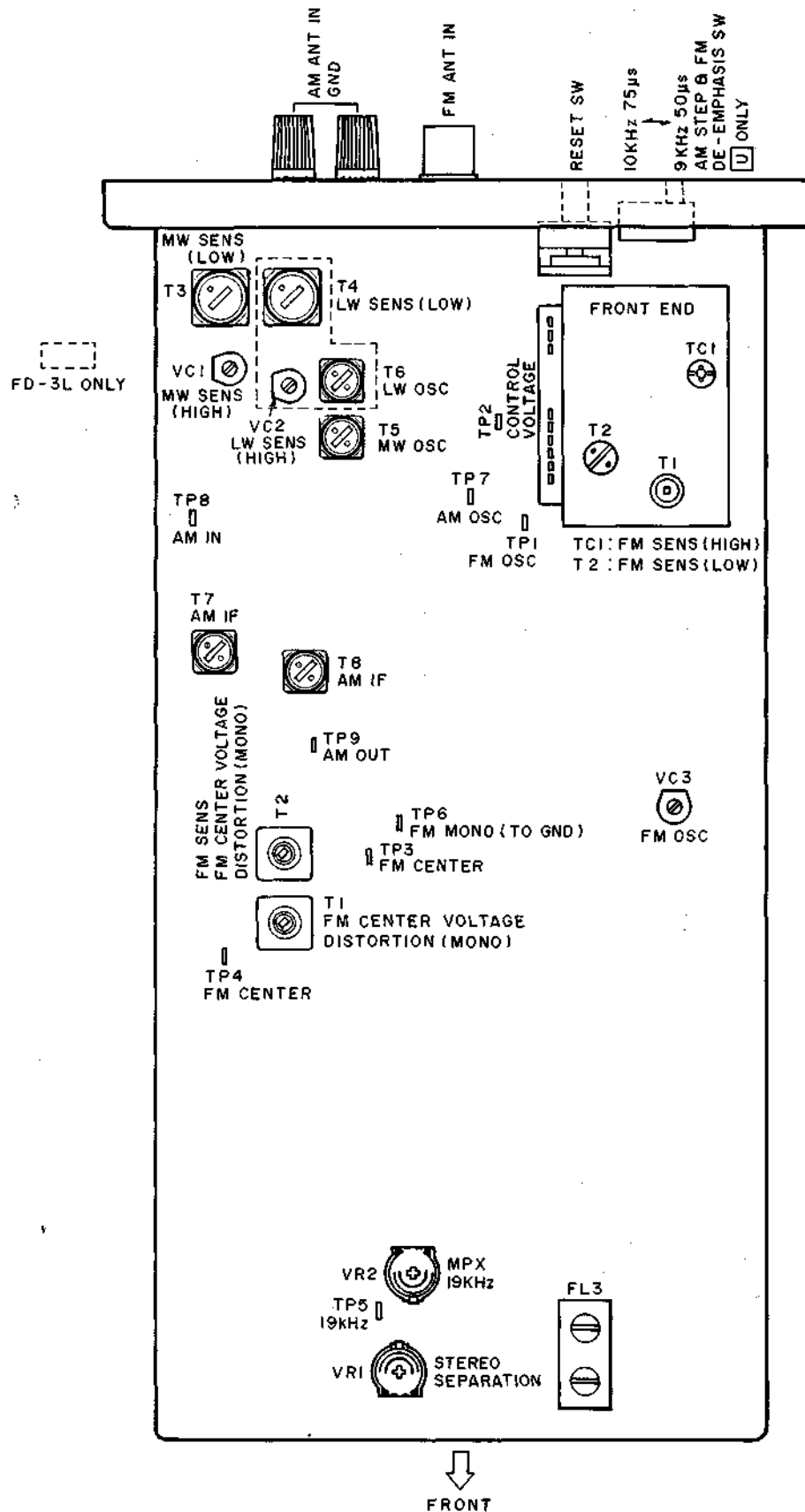

Fig. 6-2 Tuner Adjustment Points

6-2-2 FM SECTION ADJUSTMENT (Refer to Figs. 6-2 & 6-3)

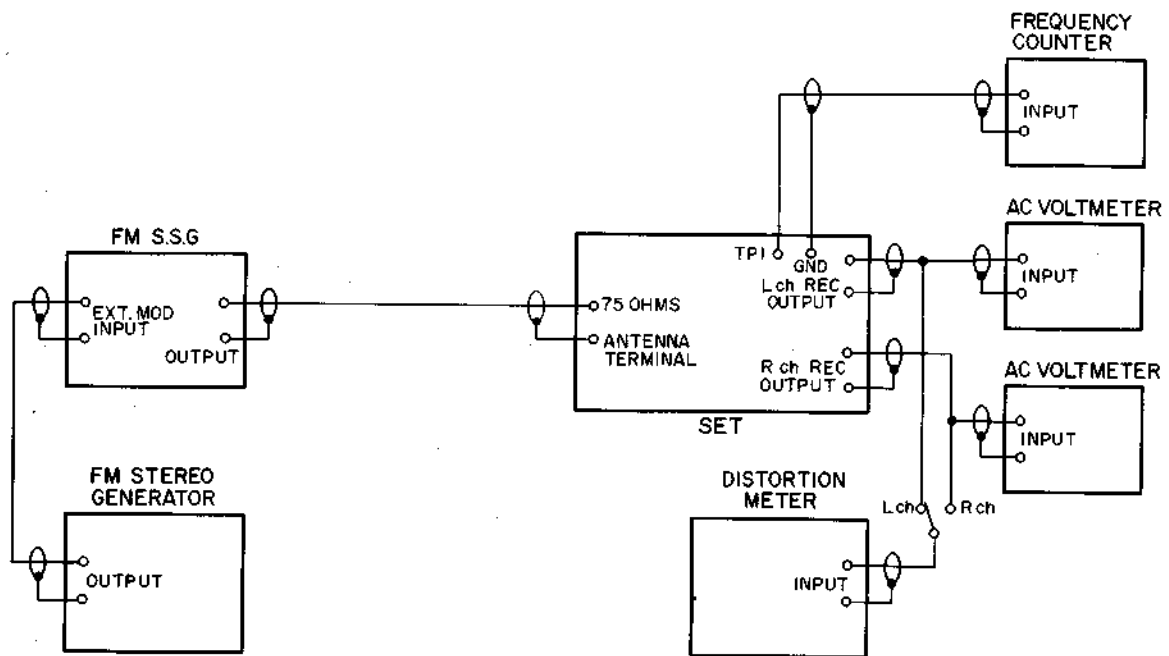

Fig. 6-3 Instrument Connections for FM Section Adjustment

Step	Adjustment Item	Adjustment Point	Result	Remarks
1	FM OSC	VC3	98.7 MHz \pm 1 kHz	<ul style="list-style-type: none"> Band to FM. Display to 88 MHz. Frequency Counter to TP1.
2	Low Range Sensitivity	T2 (FRONT END)	Less than 6 dB	<ul style="list-style-type: none"> 88 MHz, Mono input. Connect TP6 to ground. Display to 88 MHz. 3% Distortion Factor.
3	High Range Sensitivity	TC1 (FRONT END)	Less than 6 dB	<ul style="list-style-type: none"> 108 MHz input. Display to 108 MHz.
4	<ul style="list-style-type: none"> Repeat Steps 2 & 3. 			
5	FM Center Voltage	T1, 2	Centered Tuning Meter Indication	<ul style="list-style-type: none"> Center Tuning Meter between TP3 & TP4. Tune only noise without interference from broadcasting.
6	MPX 19 kHz	VR1	More than 38 dB	<ul style="list-style-type: none"> 98 MHz, 60 dB, Mono input. Display to 98 MHz. Frequency Counter to TP5.
7	Stereo Separation	VR1	More than 38 dB	<ul style="list-style-type: none"> 98 MHz, 60 dB, Stereo L CH (R CH) input. Display to 98 MHz. Minimum output of R CH (L CH).

NOTES:

- Set the internal modulation signal generator to 100% (75 kHz div.), 1 kHz of each.
- The center tuning meter such as the ones used on Models AA-R20, 30, 40, 50 or AT-2400, 2600 can be used for this adjustment. If they are not available, use a digital voltmeter (DC VOLTAGE, RANGE 20V) instead, and adjust T1, 2 so that it indicates 0V at the same condition.

6-2-3 AM (MW, LW) SECTION ADJUSTMENT (Refer to Figs. 6-2 & 6-4)

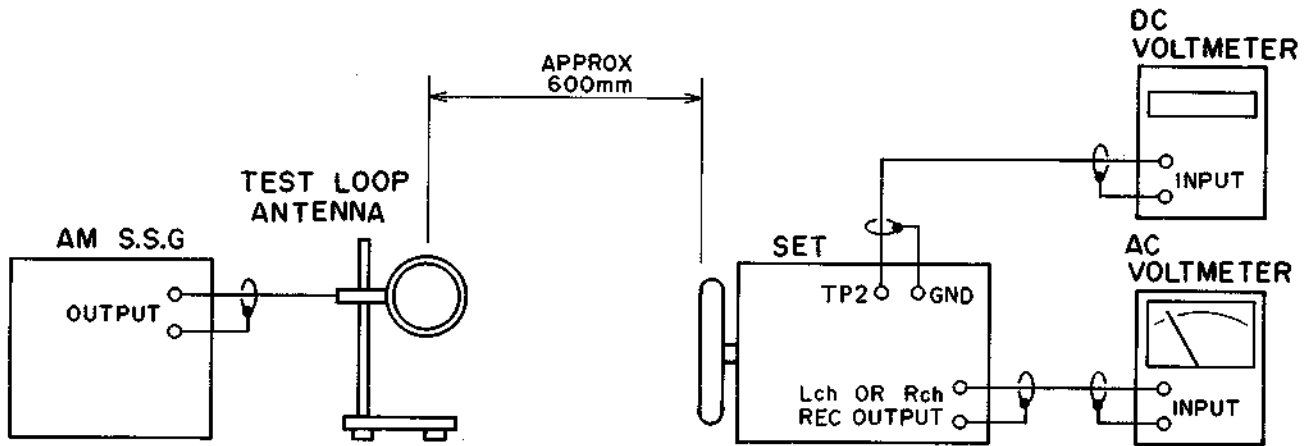

Fig. 6-4 Instrument Connections for AM Section Adjustment

Step	Adjustment Item	Adjustment Point	Result	Remarks
1	MW OSC	T5	1.8 ± 0.2V at 530 kHz (522 kHz) Less than 20V at 1,610 kHz (1,611 kHz)	<ul style="list-style-type: none"> Band to MW (AM). Voltmeter to TP2. Display to 530 kHz (522 kHz) & 1,610 kHz (1,611 kHz).
2	AM IF	T7, 8	Maximum output Minimum distortion	<ul style="list-style-type: none"> 1,000 kHz (999 kHz), 100 dB input. Display to 1,000 Hz (999 kHz).
3	MW Low Range Sensitivity	T3	Less than 60 dB	<ul style="list-style-type: none"> 600 kHz (603 kHz) input. Display to 600 kHz (603 kHz). Less than 10% Distortion Factor.
4	MW High Range Sensitivity	VC1	Less than 60 dB	<ul style="list-style-type: none"> 1,400 kHz (1,404 kHz) input. Display to 1,400 kHz (1,404 kHz).
5	● Repeat Steps 3 & 4.			
6	LW OSC	T6	1.8 ± 0.2V at 146 kHz Less than 20V at 353 kHz	<ul style="list-style-type: none"> Band to LW. Voltmeter to TP2. Display to 146 kHz & 353 kHz.
7	LW Low Range Sensitivity	T4	Less than 65 dB	<ul style="list-style-type: none"> 155 kHz input. Display to 155 kHz. Less than 10% Distortion Factor.
8	LW High Range Sensitivity	VC2	Less than 65 dB	<ul style="list-style-type: none"> 299 kHz input. Display to 299 kHz.
9	● Repeat Steps 7 & 8.			
10	TUNED Indicator level	NONE (Confirmation)	TUNED Indicator is lit.	<ul style="list-style-type: none"> Band to MW. 1,000 kHz (999 kHz), 74 dB input. Display to 1,000 kHz (999 kHz).

- NOTES: 1. Set the internal modulation signal generator to 30%, 1 kHz of each.
 2. Use a digital voltmeter for the adjustments in Steps 1 & 6.
 3. (kHz) in Result and Remarks indicates the test frequencies for AM 9 kHz STEP area.

VII. DC RESISTANCE OF VARIOUS COILS

Description	Parts Name	DC Resistance
REC/PB HEAD	HN424977	210 ohms \pm 20%
ERASE HEAD	HJ213270	3.5 ohms
PLUNGER SOLENOID	0730PLT	144 ohms \pm 10%
RELAY	LAB2NS	100 ohms
RELAY	G2R-1112PFD-V	275 ohms \pm 10%

VIII. CLASSIFICATION OF VARIOUS P.C BOARDS

8-1 P.C BOARD TITLES AND IDENTIFICATION NUMBERS

MODEL FD-3

P.C Board Title		P.C Board Number	Notes
Main Amp	P.C Board	C1003A501A	U
Main Amp	P.C Board	C1003A502A	C, A
Main Amp	P.C Board	C1003A503A	E, S
Main Amp	P.C Board	C1003A504A	V
Tuner	P.C Board	C1002B5210	U
Tuner	P.C Board	C1002B5220	C, A
Tuner	P.C Board	C1002B5230	E, V, S
Pre Amp	P.C Board	T2051A501A (2ED)	All models
Control	P.C Board	C1003A541A	All models
Function	P.C Board	C1002A5050	U, C, A, E, S
Function	P.C Board	C1002A5060	V
FLD	P.C Board	C1003A541B	All models
Timer Selector	P.C Board	C1003A541C	All models
Lamp	P.C Board	C1003A541E	All models
Speaker	P.C Board	C1003A501D	U
Speaker	P.C Board	C1003A502D	C, A
Speaker	P.C Board	C1003A503D	E, S
Speaker	P.C Board	C1003A504D	V
Connector	P.C Board	CMS01D5020	All models
Beat Cancel	P.C Board	C1003A541F	All models
Timer	P.C Board	C1003A541D	All models
Player	P.C Board	C1003A501E	U
Player	P.C Board	C1003A502E	C, A
Player	P.C Board	C1003A503E	E, S
Player	P.C Board	C1003A504E	V
Mic	P.C Board	C1003A501C	U
Mic	P.C Board	C1003A502C	C, A
Mic	P.C Board	C1003A503C	E, S
Mic	P.C Board	C1003A504C	V
Head Phone	P.C Board	C1003A501B	U
Head Phone	P.C Board	C1003A502B	C, A
Head Phone	P.C Board	C1003A503B	E, S
Head Phone	P.C Board	C1003A504B	V
Detector	P.C Board	CMS01D5010	All models
Power Supply	P.C Board	C1002B511A	U
Power Supply	P.C Board	C1002B512A	C, A
Power Supply	P.C Board	C1002B513A	E, S
Power Supply	P.C Board	C1002B514A	V
Voltage Selector	P.C Board	C1002B511B	U only
OSC	P.C Board	C1002D5450	All models

MODEL FD-3L

P.C Board P.C Board		P.C Board Number	Notes
Main Amp	P.C Board	C1003A503A	E, B
Tuner	P.C Board	C1002B5240	E, B
Pre Amp	P.C Board	T2051A501A (2ED)	
Control	P.C Board	C1003A541A	
Function	P.C Board	C1002A5050	E, B
FLD	P.C Board	C1003A541B	
Timer Selector	P.C Board	C1003A541C	
Lamp	P.C Board	C1003A541E	
Speaker	P.C Board	C1003A503D	E, B
Connector	P.C Board	CMS01D5020	
Beat Cancel	P.C Board	C1003A541F	
Timer	P.C Board	C1003A541D	
Player	P.C Board	C1003A503E	E, B
Mic	P.C Board	C1003A503C	E, B
Head Phone	P.C Board	C1003A503B	E, B
Detector	P.C Board	CMS01D5010	
Power Supply	P.C Board	C1002B513A	E, B
OSC	P.C Board	C1002D5450	

8-2 COMPOSITION OF VARIOUS P.C BOARDS

1) FD-3 TUNER P.C BOARD C1002B5210, C1002B5220 and C1002B5230

TP1	FM OSC	T1	FM CENTER VOLTAGE
TP2	CONTROL VOLTAGE	T2	DISTORTION
TP3	FM CENTER	T3	MW SENS (LOW)
TP4	FM CENTER	T5	MW OSC
TP5	19kHz	T7	AM IF
TP6	FM MONO (TO GND)	T8	
TP7	AM OSC	VC1	MW SENS (HIGH)
TP8	AM IN	VC3	FM OSC
TP9	AM OUT		

LOCATION OF COMPONENTS

IC	TR	TERMINAL
IC 1-----2B	TR 1-----2A	J1-----3A
IC 2-----2C	TR 2, 18-----2C	J2-----3C
IC 3-----2A	TR13, 14, 19, 20, 22--3B	
IC 4, 5-----3A	TR16, 17, 21-----3C	
	TR24-----1B	

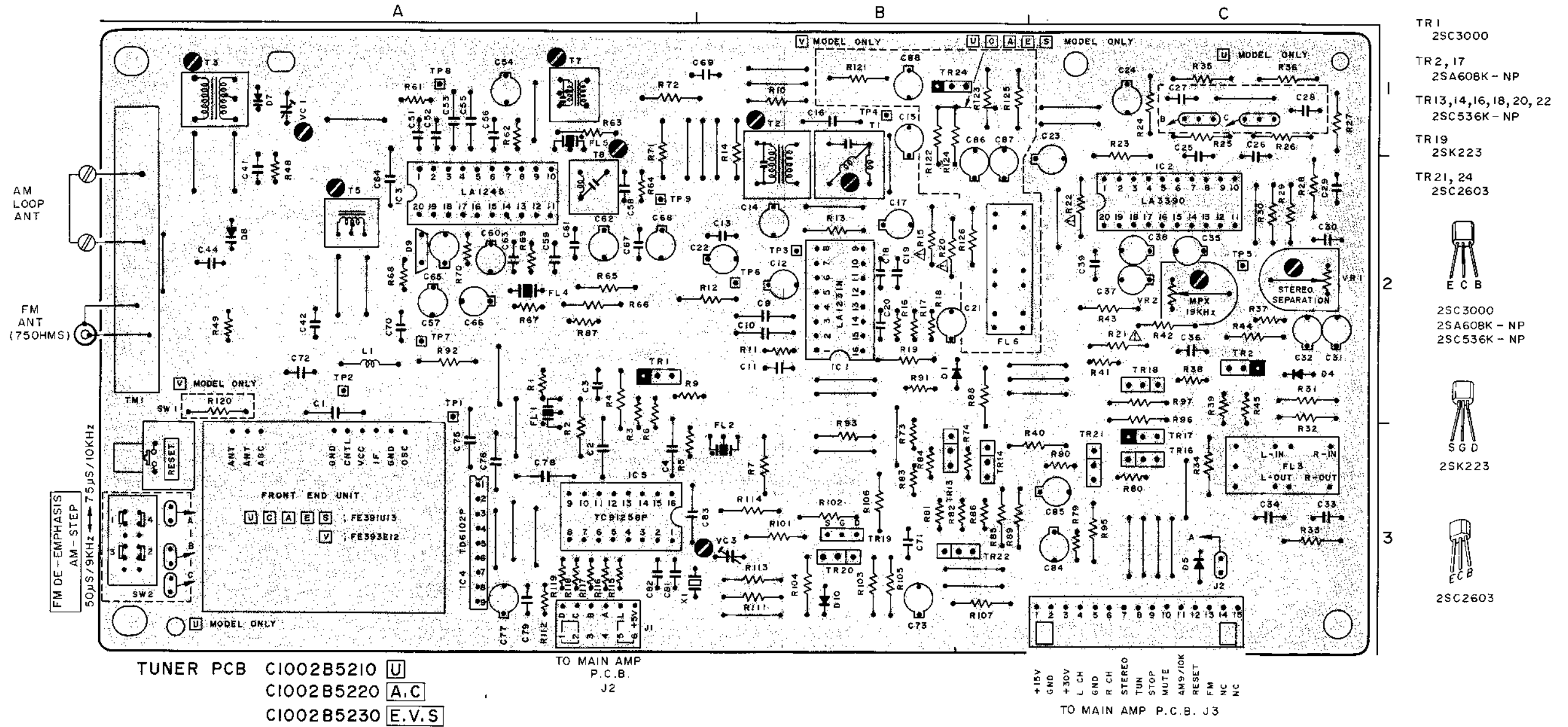

- TR 1
2SC3000
 - TR 2, 17
2SA608K - NP
 - TR 13, 14, 16, 18, 20, 22
2SC536K - NP
 - TR 19
2SK223
 - TR 21, 24
2SC2603
- ECB
- 2SC3000
 - 2SA608K - NP
 - 2SC536K - NP
- SGD
- 2SK223
- ECB
- 2SC2603

TUNER PCB C1002B5210 U
 C1002B5220 A.C
 C1002B5230 E.V.S

TO MAIN AMP P.C.B. J3

WARNING: ⚠ INDICATES SAFETY CRITICAL COMPONENTS. FOR CONTINUED SAFETY, REPLACE SAFETY CRITICAL COMPONENTS ONLY WITH MANUFACTURER'S RECOMMENDED PARTS.

AVERTISSEMENT: ⚠ IL INDIQUE LES COMPOSANTS CRITIQUES DE SÉCURITÉ. POUR MAINTENIR LE DEGRÉ DE SÉCURITÉ DE L'APPAREIL, NE REMPLACER QUE DES PIÈCES RECOMMANDÉES PAR LE FABRICANT.

2) FD-3L TUNER P.C BOARD C1002B5240

T1	FM CENTER VOLTAGE	TP1	FM OSC
T2	DISTORTION	TP2	CONTROL VOLTAGE
T3	MW SENS (LOW)	TP3	FM CENTER
T4	LW SENS (LOW)	TP4	FM CENTER
T5	MW OSC	TP5	19KHz
T6	LW OSC	TP6	FM MONO (TO GND)
T7	AM IF	TP7	AM OSC
T8	AM IF	TP8	AM IN
VC1	MW SENS (HIGH)	TP9	AM OUT
VC2	LW SENS (HIGH)		
VC3	FM OSC		

LOCATION COMPONENTS

IC	TR	TERMINAL
IC 1-----2B	TR 1, 4 to 7, 9 ---- 2A	J1---- 3A
IC 2-----2C	TR 3, 10 ----- 1A	J2---- 3C
IC 3-----2A	TR 2, 18 ----- 2C	
IC 4,5 --- 3A	TR 13, 14, 19, 20, 22 -- 3B	
	TR 11, 12, 16, 17, 21 -- 3C	

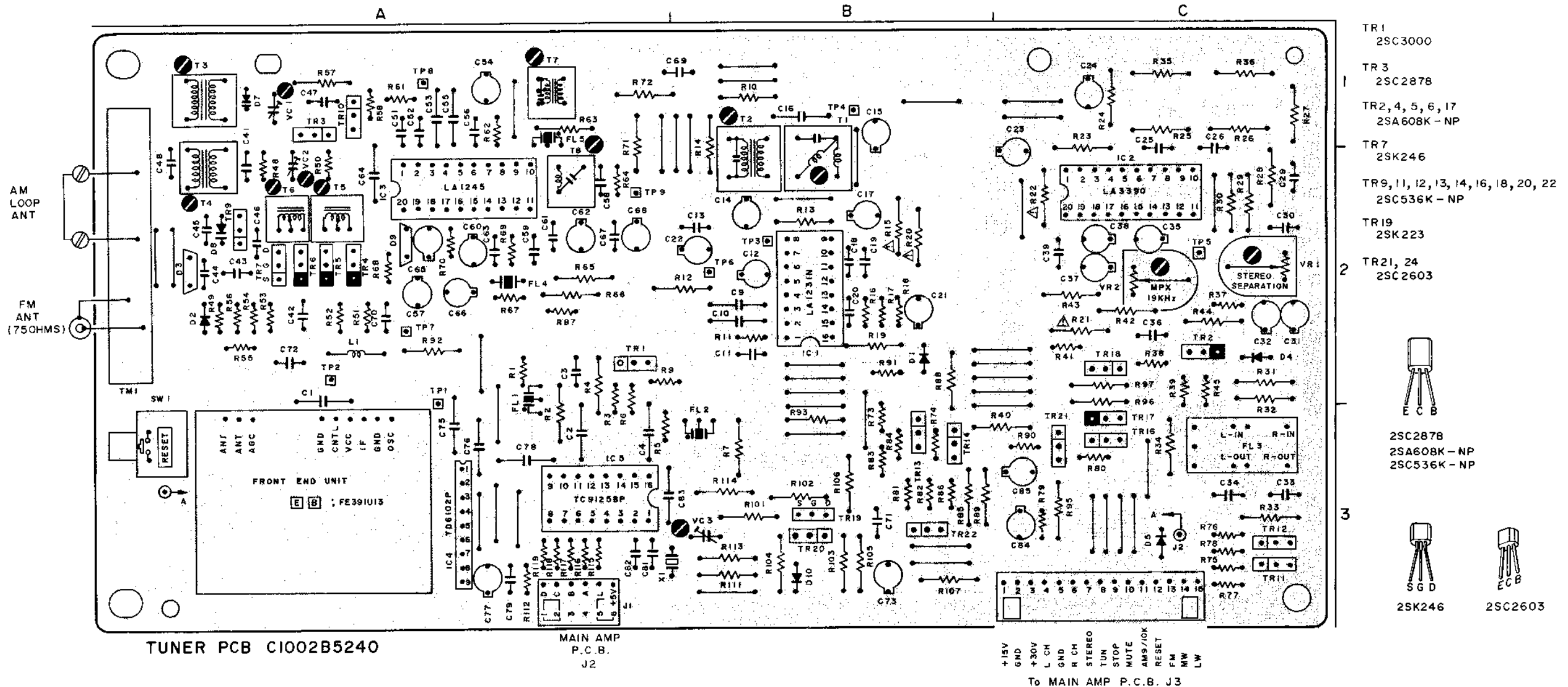

- TR1 2SC3000
 - TR3 2SC2878
 - TR2, 4, 5, 6, 17 2SA608K - NP
 - TR7 2SK246
 - TR9, 11, 12, 13, 14, 16, 18, 20, 22 2SC536K - NP
 - TR19 2SK223
 - TR21, 24 2SC2603
- ECB
- 2SC2878
2SA608K - NP
2SC536K - NP
- SGD
- 2SK246
- ECB
- 2SC2603

WARNING: Δ INDICATES SAFETY CRITICAL COMPONENTS FOR CONTINUED SAFETY. REPLACE SAFETY CRITICAL COMPONENTS ONLY WITH MANUFACTURER'S RECOMMENDED PARTS

AVERTISSEMENT: Δ IL INDIQUE LES COMPOSANTS CRITIQUES DE SÉCURITÉ. POUR MAINTENIR LE DEGRÉ DE SÉCURITÉ DE L'APPAREIL, NE REMPLACER QUE DES PIÈCES RECOMMANDÉES PAR LE FABRICANT

3) CONTROL P.C BOARD C1003A541A

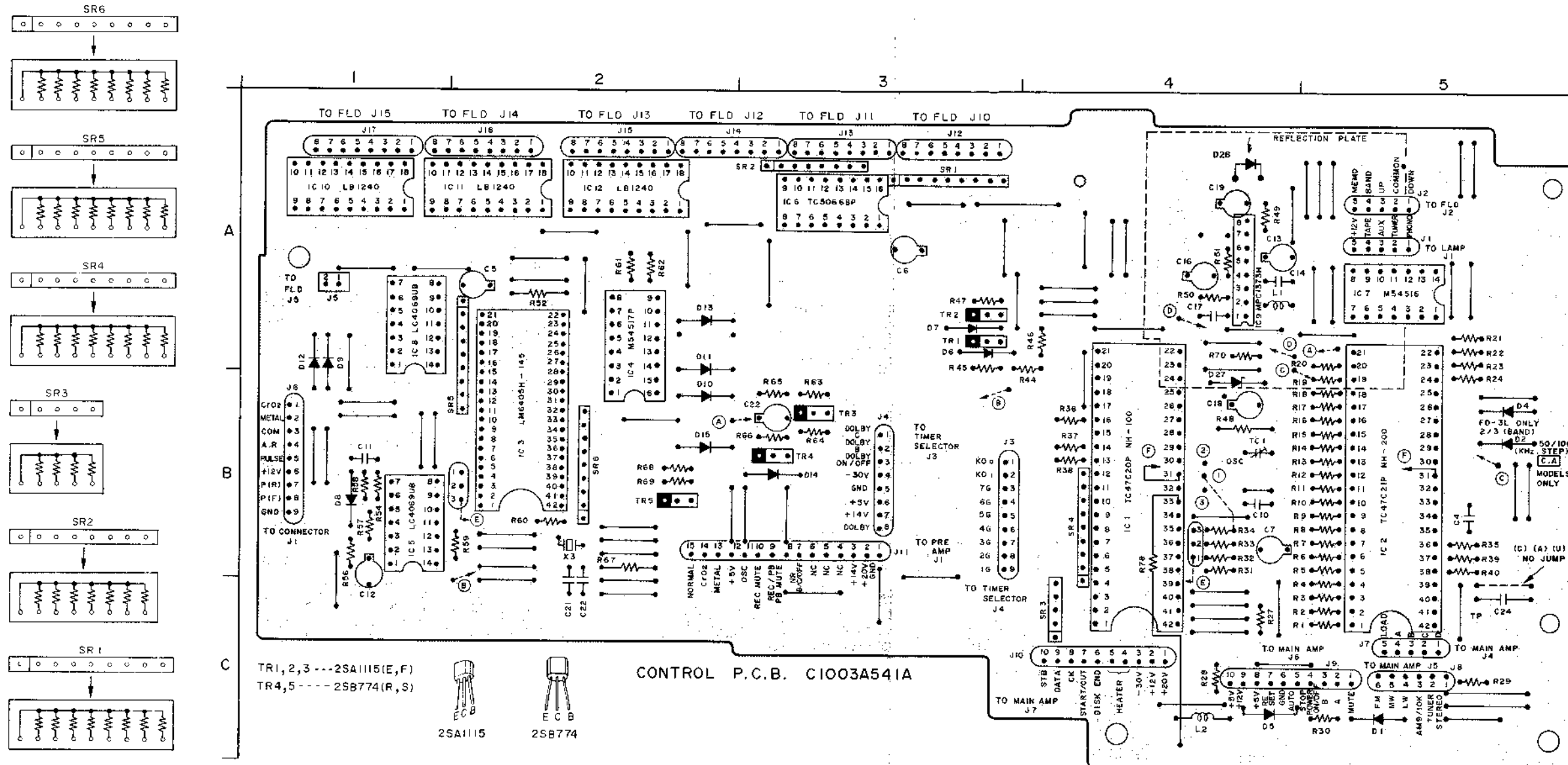

- LOCATION OF COMPONENTS
- TR
 - TR 1,2-----3A
 - TR 3,4-----3B
 - TR 5-----2B
 - IC
 - IC 1-----5B
 - IC 2-----4B
 - IC 3-----2B
 - IC 4-----2A
 - IC 5-----1B
 - IC 6-----3A
 - IC 7-----5A
 - IC 8-----1A
 - IC 9-----4A
 - IC 10-----1A
 - IC 11,12-----2A
 - TERMINAL
 - J 1,2-----5A
 - J 3-----3B
 - J 4-----3B
 - J 5-----1A
 - J 6-----1B
 - J 7,8-----5C
 - J 9,10-----4C
 - J 11-----3B
 - J 12,13-----3A
 - J 14 to 16-----2A
 - J 17-----1A

4) PRE AMP P.C BOARD T2051A501A (2ED)

LOCATION OF COMPONENTS

IC
 IC2--C4 IC2b--C2
 IC3--C5 IC3b--C1

TR
 TR1--A3 TR1b--A3
 TR2--B3 TR2b--B2
 TR3--B3 TR3b--B2
 TR4--B3 TR4b--B2
 TR5--A3 TR5b--A3
 TR8--B3 TR8b--B2
 TR9--D3
 TR10--E5 TR10b--D5
 TR11--E5 TR11b--D5
 TR12--E4 TR12b--D4
 TR13--E4 TR13b--D4
 TR14--E5 TR14b--D5
 TR15--E5 TR15b--D5
 TR16--E5 TR16b--D5
 TR17--E5 TR17b--D5
 TR18--E4
 TR19--D4
 TR20--D4
 TR22--E1
 TR23--E1
 TR24--E1
 TR25--E2
 TR26--E2
 TR28--D1
 TR30--D1
 TR31--B5 TR30b--A5
 TR32--B4 TR31b--A5
 TR33--B4 TR32b--A4
 TR34--B5 TR33b--A4

J1--C1
 P2--E3
 P3-1--B5
 P3-2--A5

① to ②--A1
 ③ to ④--B3

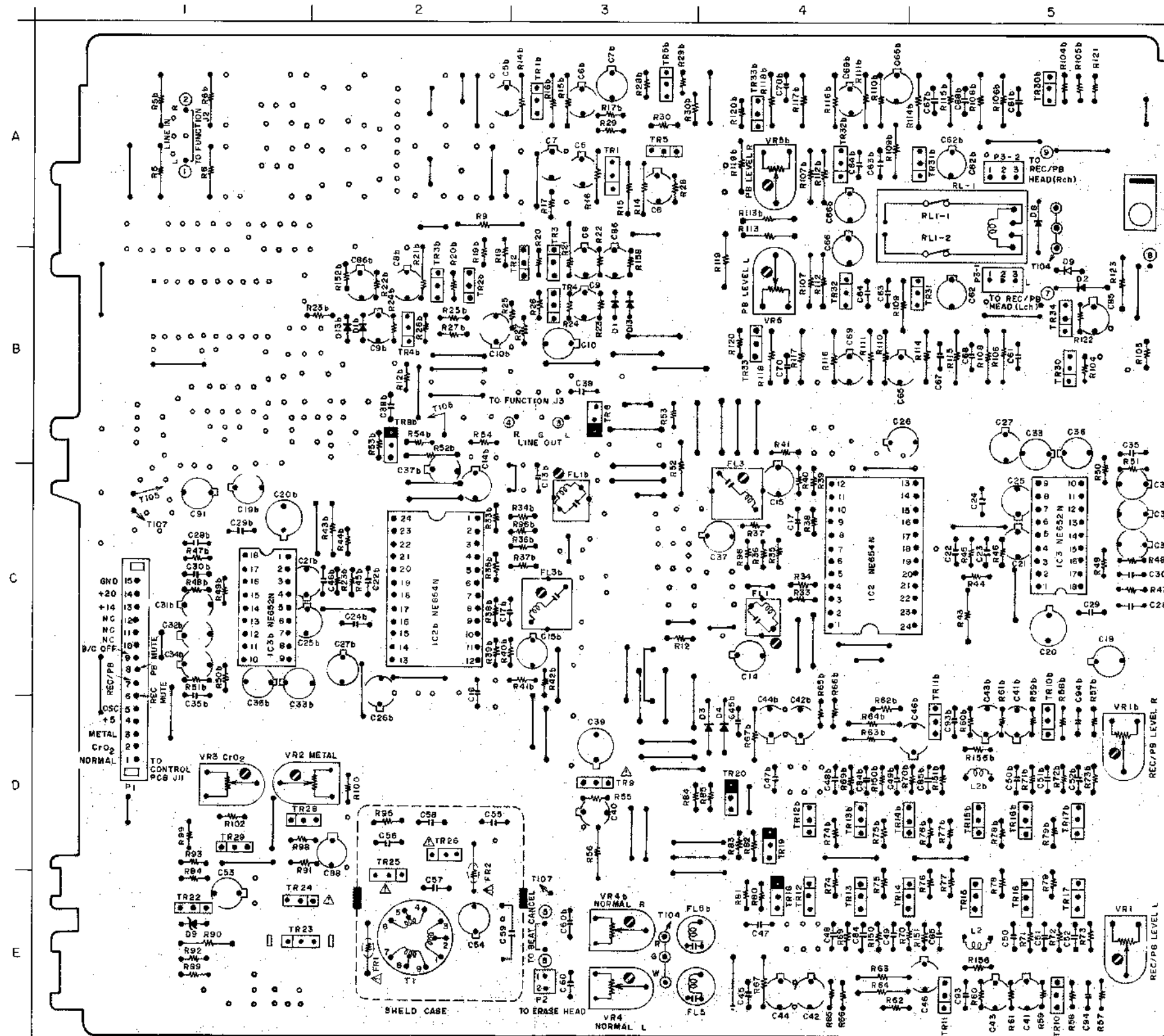
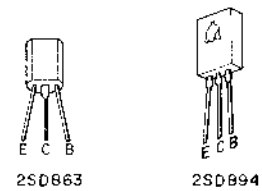
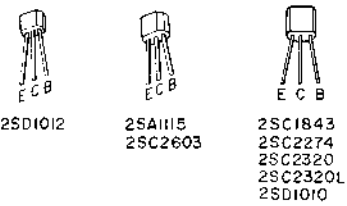

TR1, 32	2SC2320L (P, G)	TR11 to 17	2SC2320 (E, F)
TR2	2SC2603 (G)	TR18 to 20	2SA1115 (E, F)
TR3, 4, 34	2SC2603 (F, G)	TR22, 23, 28, 29, 30	2SC2603 (E, F)
TR5, 33	2SC2320 (F, G)	TR24	2SD863 (E, F)
TR8	2SD1010 (R, S)	TR25, 26	2SC2274K (E)
TR9	2SD894	TR31	2SC1843 (E, F)
TR10	2SD1012-V (E, F)		

PRE AMP PCB T2051A501A (2ED)

WARNING: ⚠ INDICATES SAFETY CRITICAL COMPONENTS. FOR CONTINUED SAFETY, REPLACE SAFETY CRITICAL COMPONENTS ONLY WITH MANUFACTURER'S RECOMMENDED PARTS.

AVERTISSEMENT: ⚠ INDIQUE LES COMPOSANTS CRITIQUES DE SÉCURITÉ. POUR MAINTENIR LE DEGRÉ DE SÉCURITÉ DE L'APPAREIL, NE REMPLACER QUE DES PIÈCES RECOMMANDÉES PAR LE FABRICANT.

5) MAIN AMP P.C BOARD C1003A501A, C1003A502A, C1003A503A and C1003A504A

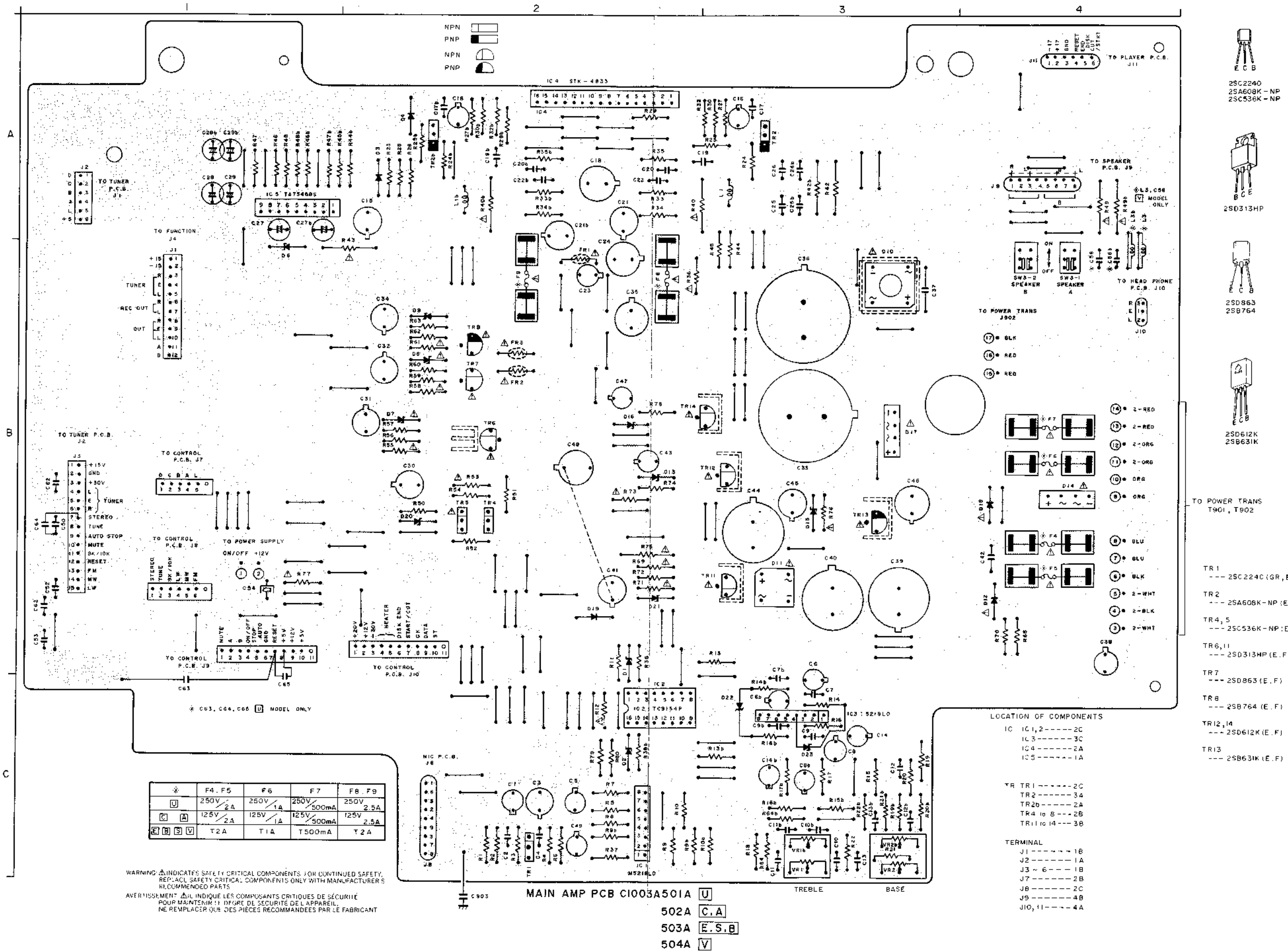

WARNING: \triangle INDICATES SAFETY CRITICAL COMPONENTS. FOR CONTINUED SAFETY, REPLACE SAFETY CRITICAL COMPONENTS ONLY WITH MANUFACTURER'S RECOMMENDED PARTS.
 AVERTISSEMENT: \triangle IL INDIQUE LES COMPOSANTS CRITIQUES DE SÉCURITÉ. POUR MAINTENIR LE DEGRÉ DE SÉCURITÉ DE L'APPAREIL, NE REMPLACEZ QUE DES PIÈCES RECOMMANDÉES PAR LE FABRICANT.

	F4, F5	F6	F7	F8, F9
U	250V / 2A	250V / 1A	250V / 500mA	250V / 2.5A
A	125V / 2A	125V / 1A	125V / 500mA	125V / 2.5A
B	T2A	T1A	T500mA	T2A

- LOCATION OF COMPONENTS**
- IC 1,2----2C
 - IC 3-----3C
 - IC 4-----2A
 - IC 5-----1A
- TR**
- TR1-----2C
 - TR2-----3A
 - TR2b-----2A
 - TR4 to 8---2B
 - TR11 to 14---3B
- TERMINAL**
- J1-----1B
 - J2-----1A
 - J3-----1B
 - J7-----2B
 - J8-----2C
 - J9-----4B
 - J10, 11---4A

6) POWER SUPPLY P.C BOARD C1002B511A, VOLTAGE SELECTOR P.C BOARD C1002B511B

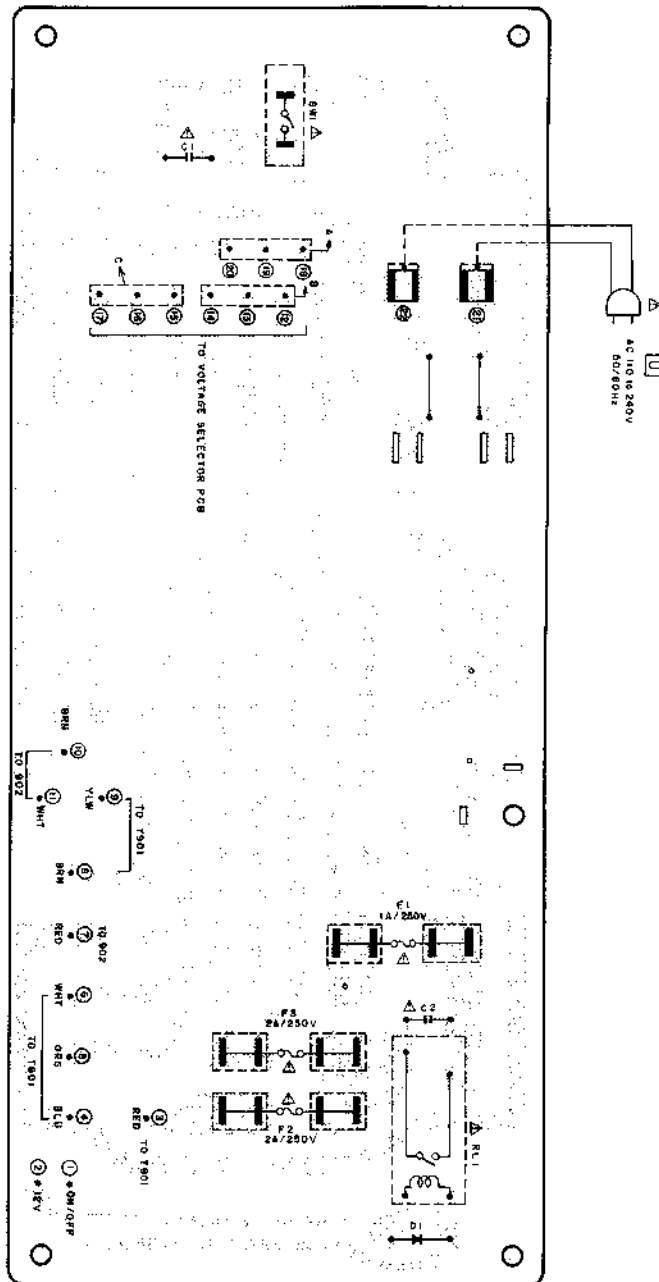
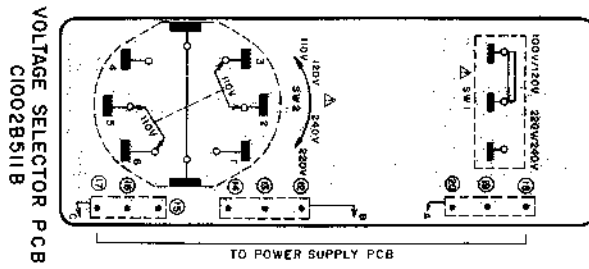

WARNING: INDICATES SAFETY CRITICAL COMPONENTS FOR CONTINUED SAFETY.
 REPLACE SAFETY CRITICAL COMPONENTS ONLY WITH MANUFACTURERS
 RECOMMENDED PARTS OR EQUIVALENTS.
 AVERTISSEMENT: INDICATE LES COMPOSANTS CRITIQUES DE SÉCURITÉ.
 POUR MAINTENIR LE DEGRÉ DE SÉCURITÉ DE L'APPAREIL.
 NE REMPLACER QUE DES PIÈCES RECOMMANDÉES PAR LE FABRICANT

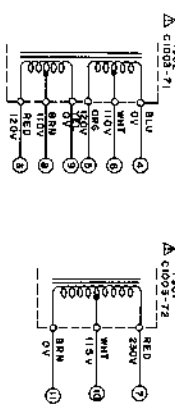

7) POWER SUPPLY P.C BOARD C1002B512A

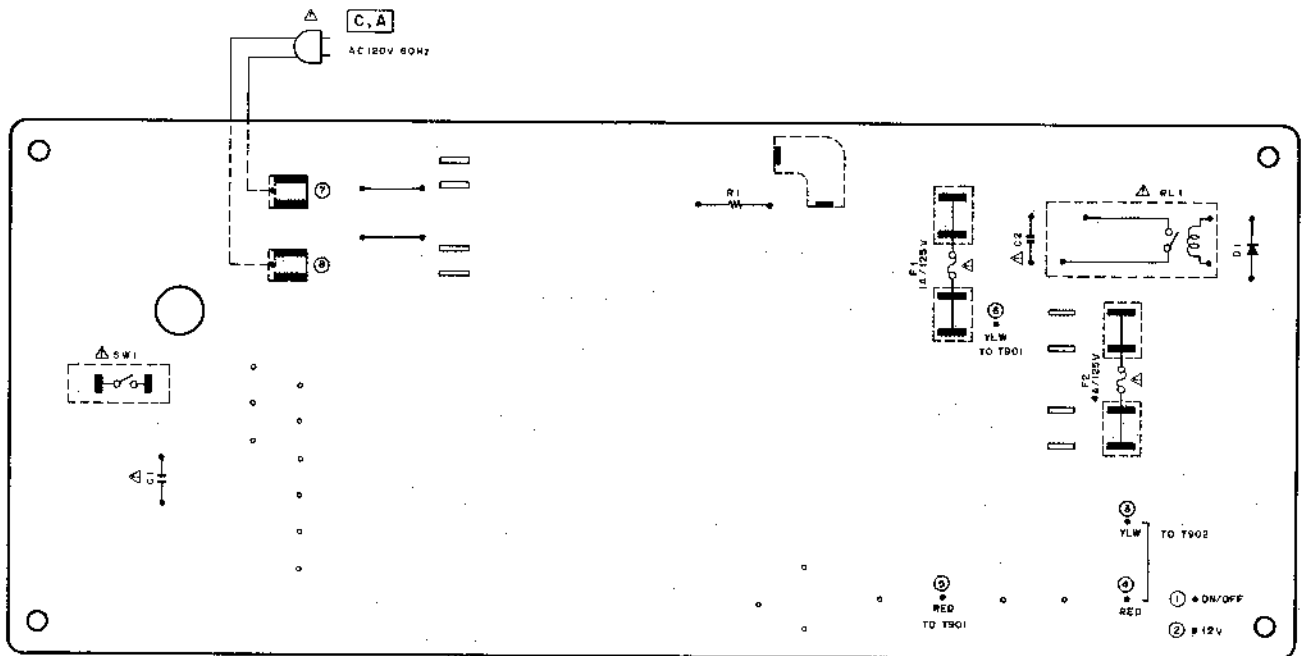

POWER SUPPLY PCB C1002B512A

WARNING: Δ INDICATES SAFETY CRITICAL COMPONENTS FOR CONTINUED SAFETY. REPLACE SAFETY CRITICAL COMPONENTS ONLY WITH MANUFACTURER'S RECOMMENDED PARTS.
 AVERTISSEMENT: Δ ILL INDIQUE LES COMPOSANTS CRITIQUES DE SÉCURITÉ. POUR MAINTENIR LE DEGRÉ DE SÉCURITÉ DE L'APPAREIL, NE REMPLACER QUE DES PIÈCES RECOMMANDÉES PAR LE FABRICANT.

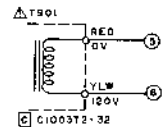
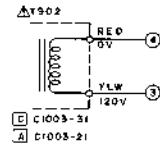

8) POWER SUPPLY P.C BOARD C1002B513A

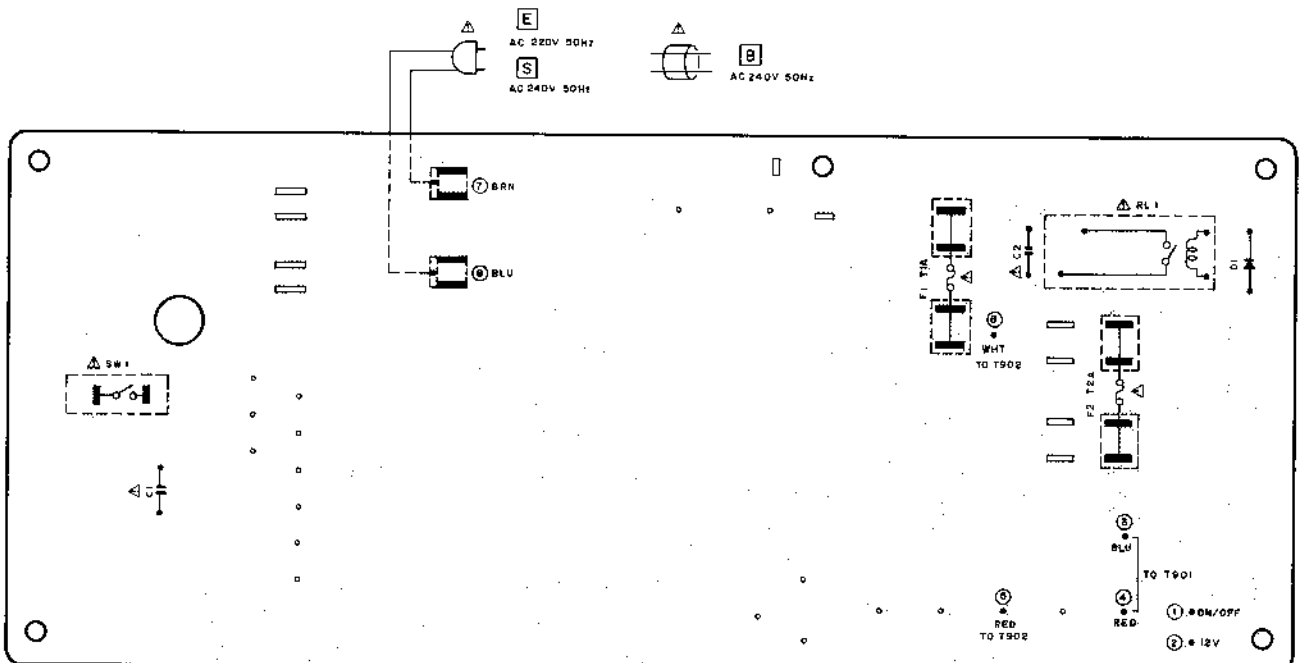

POWER SUPPLY PCB C1002B513A

WARNING: Δ INDICATES SAFETY CRITICAL COMPONENTS FOR CONTINUED SAFETY. REPLACE SAFETY CRITICAL COMPONENTS ONLY WITH MANUFACTURER'S RECOMMENDED PARTS.
 AVERTISSEMENT: Δ ILL INDIQUE LES COMPOSANTS CRITIQUES DE SÉCURITÉ. POUR MAINTENIR LE DEGRÉ DE SÉCURITÉ DE L'APPAREIL, NE REMPLACER QUE DES PIÈCES RECOMMANDÉES PAR LE FABRICANT.

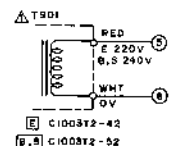
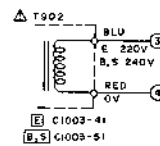

9) POWER SUPPLY P.C BOARD C1002B514A

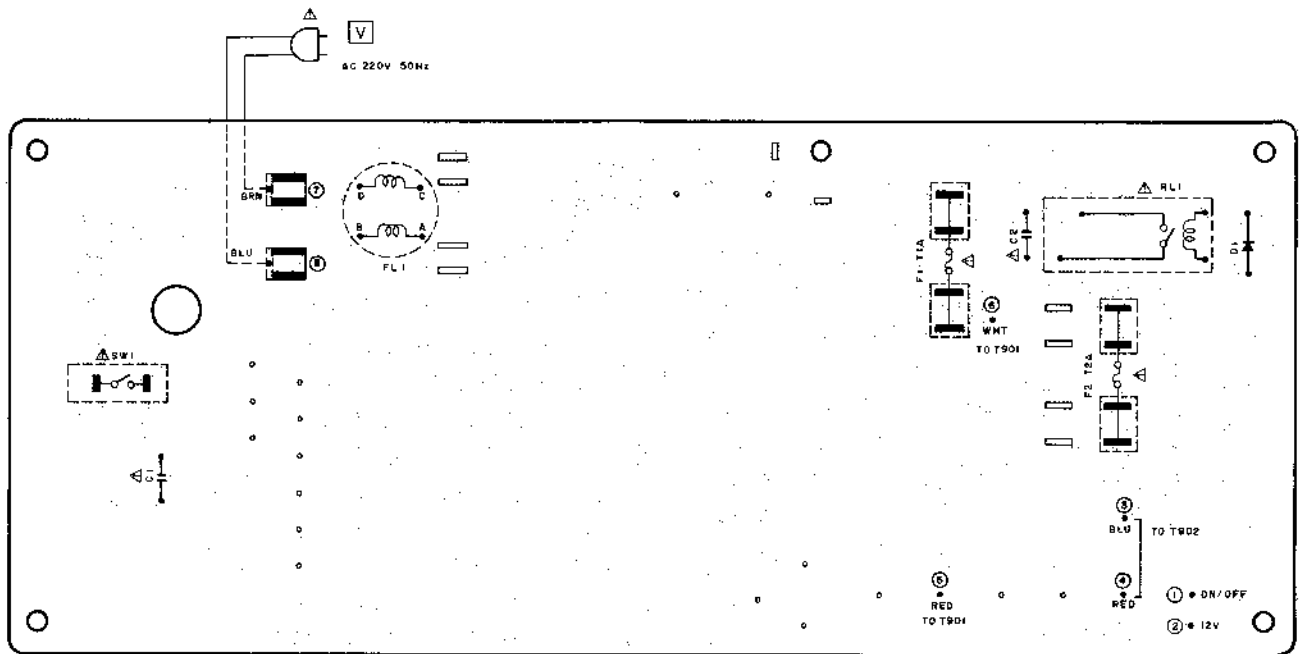

POWER SUPPLY PCB C1002B514A

WARNING: Δ INDICATES SAFETY CRITICAL COMPONENTS. FOR CONTINUED SAFETY, REPLACE SAFETY CRITICAL COMPONENTS ONLY WITH MANUFACTURER'S RECOMMENDED PARTS.
 AVERTISSEMENT: Δ INDIQUE LES COMPOSANTS CRITIQUES DE SÉCURITÉ POUR MAINTENIR LE DEGRÉ DE SÉCURITÉ DE L'APPAREIL. NE REMPLACER QUE DES PIÈCES RECOMMANDÉES PAR LE FABRICANT.

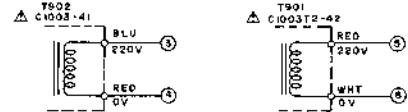

10) FUNCTION P.C BOARD C1002A5050 and C1002A5060

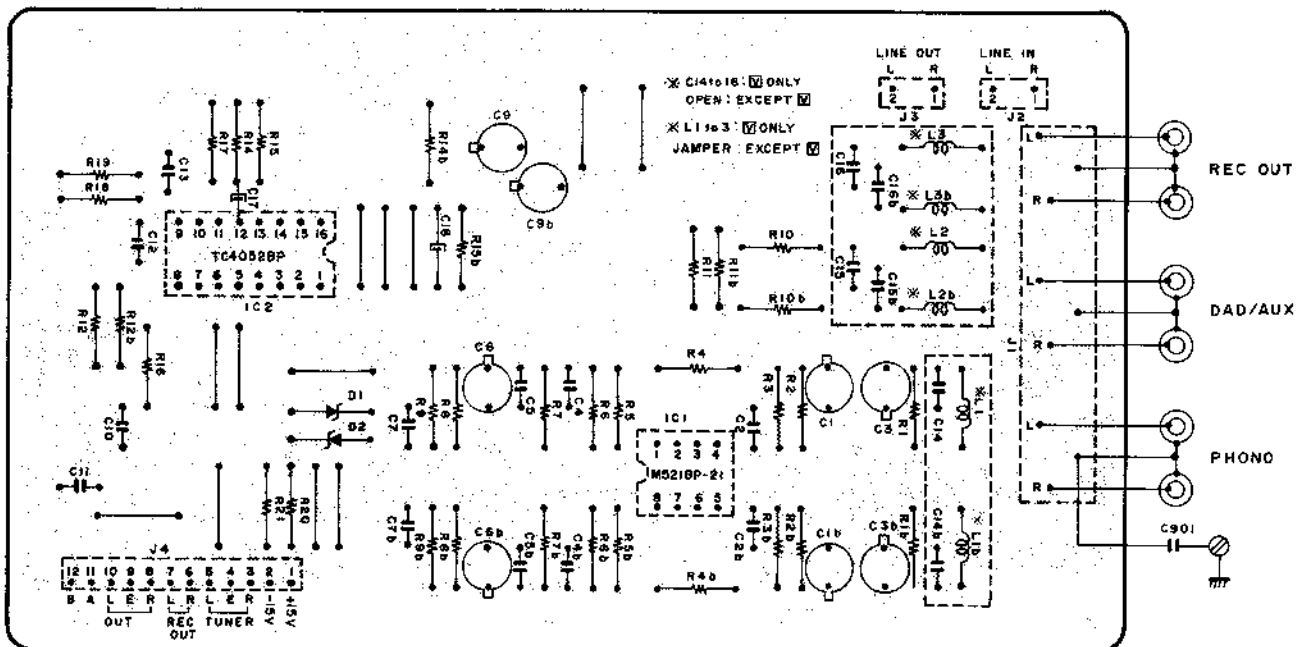

FUNCTION PCB
 C1002A5050 \square \square \square \square \square \square \square \square
 C1002A5060 \square

11) FLD P.C BOARD C1003A541B

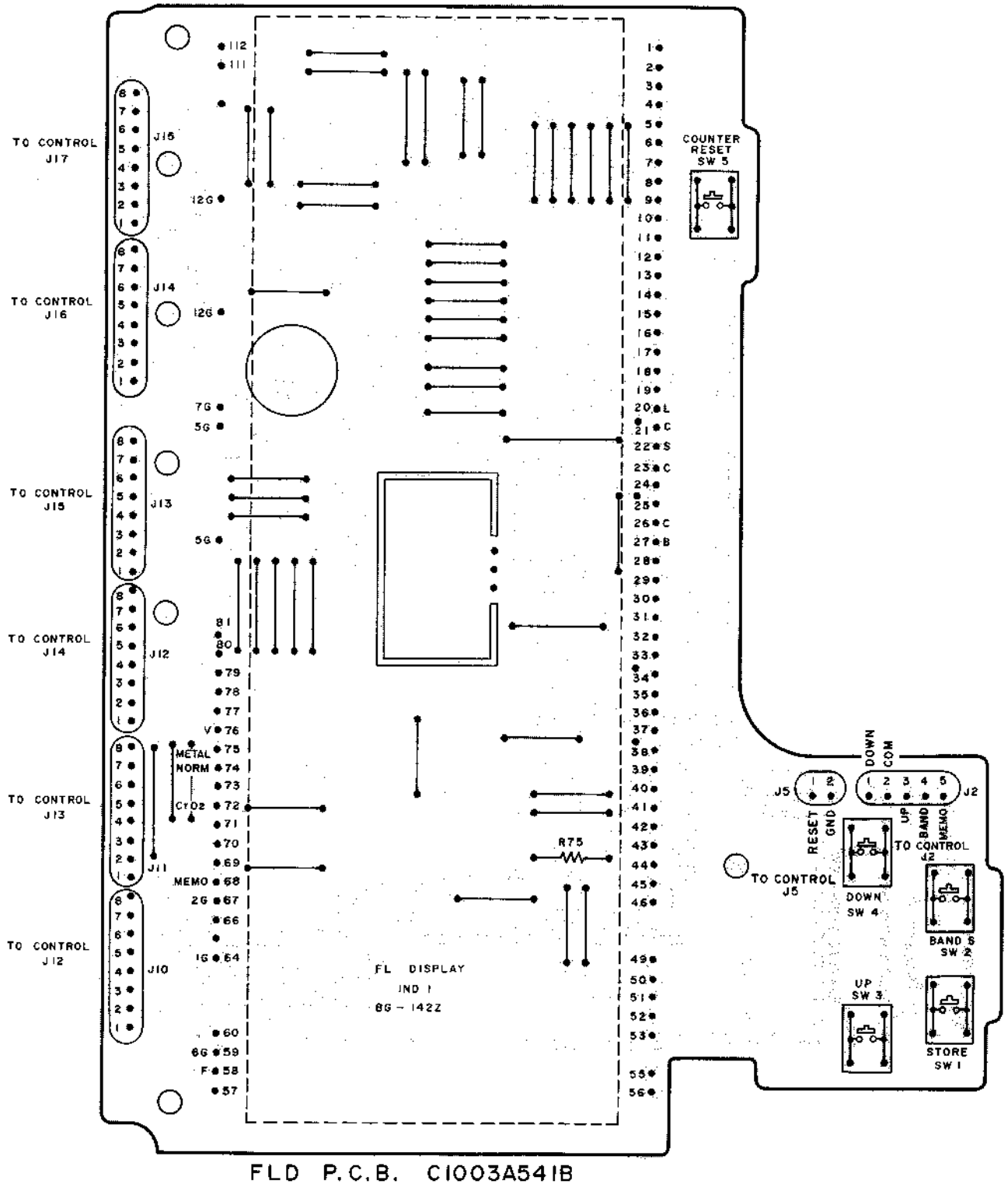

12) OTHER P.C BOARDS

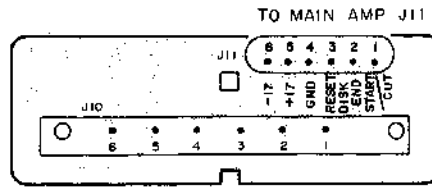

PLAYER P.C.B

U	C1003A501E		
C	A	502E	
E	S	B	503E
V			504E

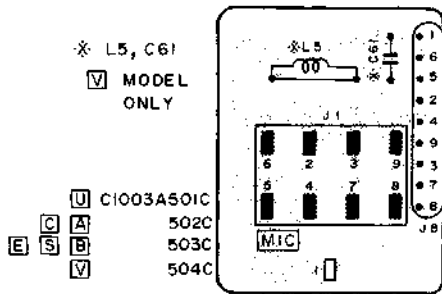

MIC P.C.B

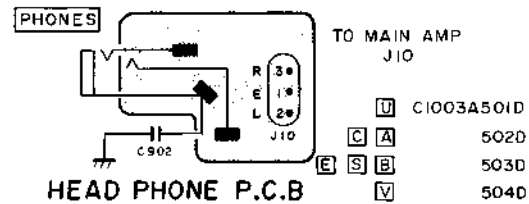

HEAD PHONE P.C.B

U	C1003A501C	502C	
C	A	503C	
E	S	B	504C
V			

U	C1003A501D	502D	
C	A	503D	
E	S	B	504D
V			

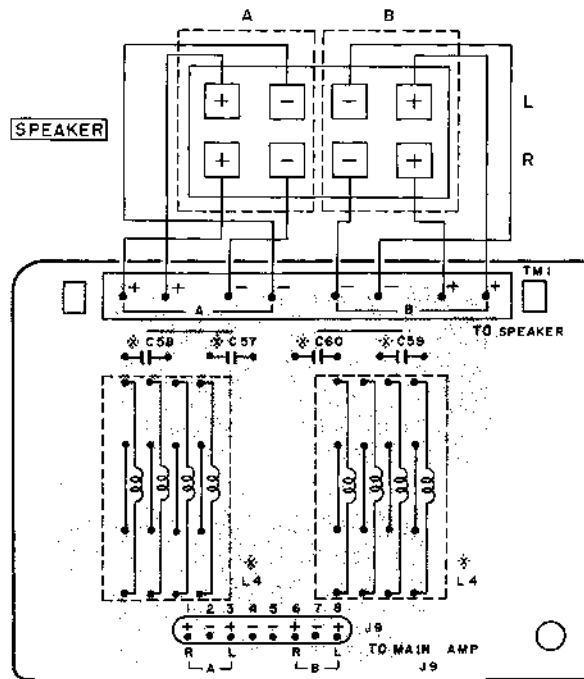

SPEAKER P.C.B

U	C1003A501B		
C	A	502B	
E	S	B	503B
V			504B

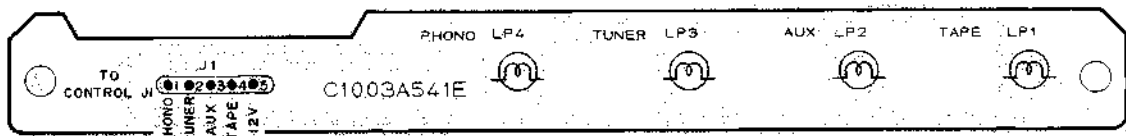

LAMP PCB C1003A541E

TIMER SELECTOR PCB C1003A541C

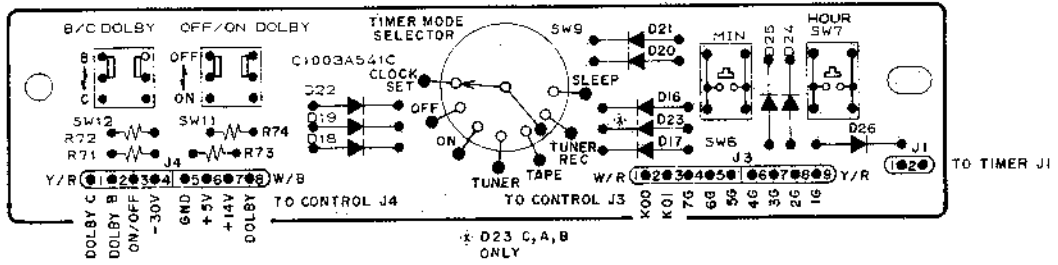

BEAT CANCEL PCB C1003A541F

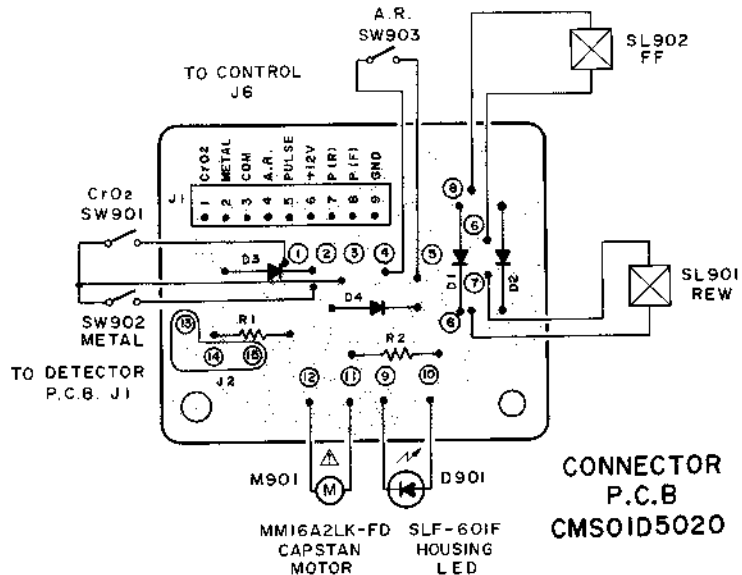
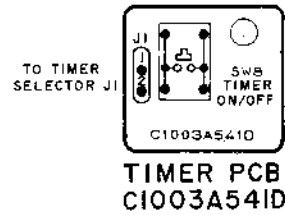
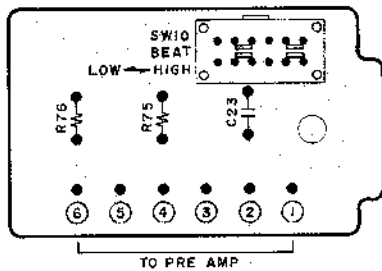

WARNING: Δ INDICATES SAFETY CRITICAL COMPONENTS FOR CONTINUED SAFETY. REPLACE SAFETY CRITICAL COMPONENTS ONLY WITH MANUFACTURER'S RECOMMENDED PARTS.

AVERTISSEMENT: Δ IL INDIQUE LES COMPOSANTS CRITIQUES DE SÉCURITÉ. POUR MAINTENIR LE DEGRÉ DE SÉCURITÉ DE L'APPAREIL, NE REMPLACER QUE DES PIÈCES RECOMMANDÉES PAR LE FABRICANT.

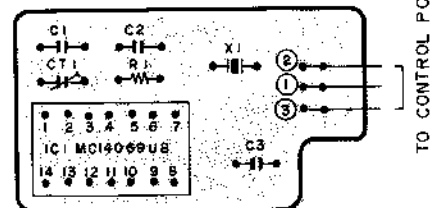
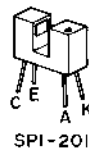
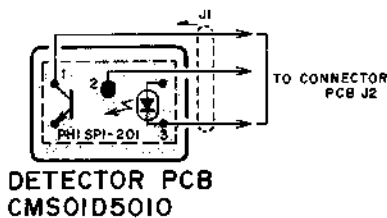

OSC PCB C1002D5450

SECTION 2

PARTS LIST

TABLE OF CONTENTS

RECOMMENDED SPARE PARTS	33
1. MECHA CMS01 BLOCK (1/2)	34
2. MECHA CMS01 BLOCK (2/2)	36
3. MAIN P.C BOARD BLOCK	38
4. PRE AMP P.C BOARD BLOCK	39
5. CONTROL P.C BOARD BLOCK	39
6. TUNER P.C BOARD BLOCK	40
7. FUNCTION P.C BOARD BLOCK	40
8. POWER SUPPLY P.C BOARD BLOCK	41
9. CONNECTOR P.C BOARD BLOCK	41
10. CHASSIS FRONT BLOCK	41
11. REMOTE CONTROL BLOCK	42
12. ASSEMBLY BLOCK	44
13. FRONT PANEL BLOCK	46
INDEX	47

Resistor and Capacitor which is not listed in this parts list, please refer to COMMON LIST FOR SERVICE PARTS.

ATTENTION

1. When placing an order for parts, be sure to list the parts no., model no., and description. There are instances in which if any of this information is omitted, parts cannot be shipped or the wrong parts will be delivered.
2. Please be careful not to make a mistake in the parts no. If the parts no. is in error, a part different from the one ordered may be delivered.
3. Because parts number and parts unit supply in the Preliminary Parts List may be partially changed, please use this parts list for all future reference.

HOW TO USE THIS PARTS LIST

1. This Parts List shows the parts that are considered necessary for repairs. Other parts, such as resistors and capacitors, are shown in the "Common List for Service Parts". Select and order such parts from the "Common List for Service Parts".
2. The Recommended Spare Parts shows those parts in the Parts List which are considered particularly important for service.
3. Parts not shown in the Parts List and "Common List for Service Parts" will not be supplied in principle.
4. How to read list
 - a) Mechanism Block
 - b) P.C Board Block

2. HEAD BASE BLOCK

REF. NO.	PARTS NO.	DESCRIPTION
2-1x	BH-T2023A320A	HEAD BASE BLOCK GX-F66R
2-2	HP-H2206A010A	HEAD R/P PR4-8FU C
2-3	ZS-477876	PAN20x03STL CMT
2-4	ZS-536488	BID20x08STL CMT
2-5	ZG-402895	CS ANGLE ADJUST SPRING

SP (Service Parts) Classification

A small "x" indicates the inability to show that particular part in the Photo or Illustration.

This number corresponds with the individual parts index number in that figure

This number corresponds with the Figure Number

6. SYS. CON. P.C BOARD BLOCK

REF. NO.	PARTS NO.	DESCRIPTION
6-1	BA-T2034A070A	PC SYS CON BLK GX-F44R
6-1C1	EI-324536	IC HD14049BP
6-1C2	EI-336801	IC MB8841-564M
6-1C3	EI-331661	IC SN7405N
6-1C4	EI-336725	IC M54527P
6-TR1to4	ET-200985	TR 2SC2603 F,G
6-TR5to28	ET-554657	TR 2SA733A P,Q
6-D1	ED-318292	D SILICON H 1S2473T-77 T26
6-D2to4	ED-308952	D GERMA V 1K34A-LR F07
6-D5to10	ED-318292	D SILICON H 1S2473T-77 T26
6-X1	EI-318384	OSC X'TAL NC-18C 3.579545MHZ

SP (Service Parts) Classification

This reference numbers corresponds with symbol numbers of Schematic Diagrams.

5. Both the kind of part and installation position can be determined by the Parts Number. To determine where a parts number is listed, utilize Parts Index at end of Parts List. It is necessary first of all to find the Parts Number. This can be accomplished by using the Reference Number listed at right of parts number in the Parts Index.

WARNING

△ INDICATES SAFETY CRITICAL COMPONENTS. FOR CONTINUED SAFETY, REPLACE SAFETY CRITICAL COMPONENTS ONLY WITH MANUFACTURER'S RECOMMENDED PARTS.

AVERTISSEMENT

△ IL INDIQUE LES COMPOSANTS CRITIQUES DE SURETE. POUR MAINTENIR LE DEGRE DE SECURITE DE L'APPAREIL NE REMPLACER LES COMPOSANTS DONT LE FONCTIONNEMENT EST CRITIQUE POUR LA SECURITE QUE PAR DES PIECES RECOMMANDEES PAR LE FABRICANT.

NO.	PARTS NO.	DESCRIPTION
71	EL-347456	PL MINI BASE 14.0V 50MA
72	EM-347469	IND FL BG-142Z DOUBLE
73	EO-337774	COIL OSC 1 0365-056 100.0KHZ
74	EO-202215	COIL OSC 2 7NR-6721Y 100.0μH
75	EO-307786	COIL OSC 2 7NR-6722Y 580.0μH
76	EO-337598	COIL VARI 2 25A-1353-01
77	EO-337599	COIL VARI 2 25A-1354-03
78	EP-337067	RELAY LEAD LAB2NS 2NO 18V
79	ER-337327	FILTER CE BFU459C4N 0.459MHZ
80	ER-337328	FILTER CE BFU460C4N 0.46MHZ
81	ER-338338	FILTER CE MS3GKY-A 10.700MHZ
82	ER-336804	FILTER CE SFE10.7MA8 10.7MHZ
83	ER-345729	FILTER CE SFE10.7M21KA 10.7MHZ
84	ER-343352	FILTER CE SFU459B9 0.459MHZ
85	ER-343353	FILTER CE SFU460B9 0.460MHZ
86	ER-336830	FILTER LC LP BL-34HD
87	ER-341654	FILTER LC LP 42W-1001
88	ER-315407	FILTER CE SFE10.7MKA 10.7MHZ
89	ER-328067	R CB H S10 FS RDS 1/4W 331J
90	ER-343420	R COMP EXB-P84104K
91	ER-347438	R COMP EXB-P87104K
92	ER-347437	R COMP EXB-P88 104K
93	ER-347688	R COMP EXB-P88 472K
94	ER-347164	R COMP RKC 1/8 B8 223J
95	ES-344253	SW LEAF MSW-1418J 01-1 NO
96	ES-344257	SW LEAF MSW-1418L 01-1 NO
97	ES-347966	SW PUSH ESB-649 01-2-2 N
98	ES-347616	SW PUSH J-K1121#01 2THROW
99	ES-347436	SW ROTARY SRM1017 1-01-07S
100	ES-347617	SW SELECTOR 0240#02 01-4
101	ES-348463	SW SLIDE X012B11Y 01-2
102	ES-344439	SW SLIDE 00420451 2-04-02
103	ES-344439	SW SLIDE 00420451 2-04-02 (U)
104	ES-344445	SW TACT EVQ-QHR12B
105	ES-336780	SW TACT KHH10902
106	ET-330717	PHOTO SENSOR NJL1644L
107	ET-311977	PHOTO SENSOR SPI-201
108	ET-330588	TR FET 2SK19 O, Y
109	ET-336937	TR FET 2SK223 E, F
110	ET-337604	TR FET 2SK246 Y
111	ET-200558	TR 2SA1115 E,F
112	ET-322778	TR 2SA608K-NP E,F,G
113	ET-301165	TR 2SB631K E,F
114	ET-318237	TR 2SB764 E,F
115	ET-338081	TR 2SB774 R,S
116	ET-337258	TR 2SC1843 E,F
117	ET-307195	TR 2SC2240 GR,BL
118	ET-310833	TR 2SC2274K E
119	ET-328578	TR 2SC2320 E,F
120	ET-344275	TR 2SC2320L F,G
121	ET-330464	TR 2SC2603 D,E
122	ET-200505	TR 2SC2603 E,F
123	ET-200985	TR 2SC2603 F,G
124	ET-308141	TR 2SC2603 G
125	ET-338410	TR 2SC2878 A,B
126	ET-336935	TR 2SC3000 E,F
127	ET-322775	TR 2SC536K-NP E,F,G
128	ET-332421	TR 2SD1010 R,S
129	ET-328437	TR 2SD1012-V F,G
130	ET-452531	TR 2SD313HP E,F
131	ET-310148	TR 2SD612K E,F
132	ET-318239	TR 2SD863 E,F
133	ET-201580	TR 2SD894
134	EV-315416	R S-FIX H D8 3P 103
135	EV-315414	R S-FIX H D8 3P 203
136	EV-322413	R S-FIX H D8 3P 302
137	EV-315413	R S-FIX H D8 3P 503
138	EV-337995	R S-FIX H RVF8P01 3P 103
139	EV-337993	R S-FIX H RVF8P01 3P 203
140	EV-336785	R S-FIX H TM8KV2-1S 3P 0.50W 104
141	EV-347615	VR ROTARY 16P20x3A C104
142	EV-347614	VR ROTARY 16P20x3B C104
143	HE-337047	HEAD E HJ213270 C
144	HP-344252	HEAD R/P HN424977
145	MB-344231	BELT 1.0xD33.3CR HS60
146	MB-344905	BELT 1.2xD38.2 CR HS60
147	MB-344230	BELT 3.0x0.5TxD61CRHS60

NO.	PARTS NO.	DESCRIPTION
148	MI-B344207	ARM IDLER FR PART
149	MI-B344215	ARM IDLER TU PART
150	MP-336153	PINCH ROLLER (A)
151	MT-344187	REEL TABLE
152	MZ-344297	DUMPER ASSY
153	TA-347458	FRONT END FE391U13 88-108MHZ
154	TA-347459	FRONT END FE393E12 88-108MHZ

MECHA CMS01 BLOCK (1/2)

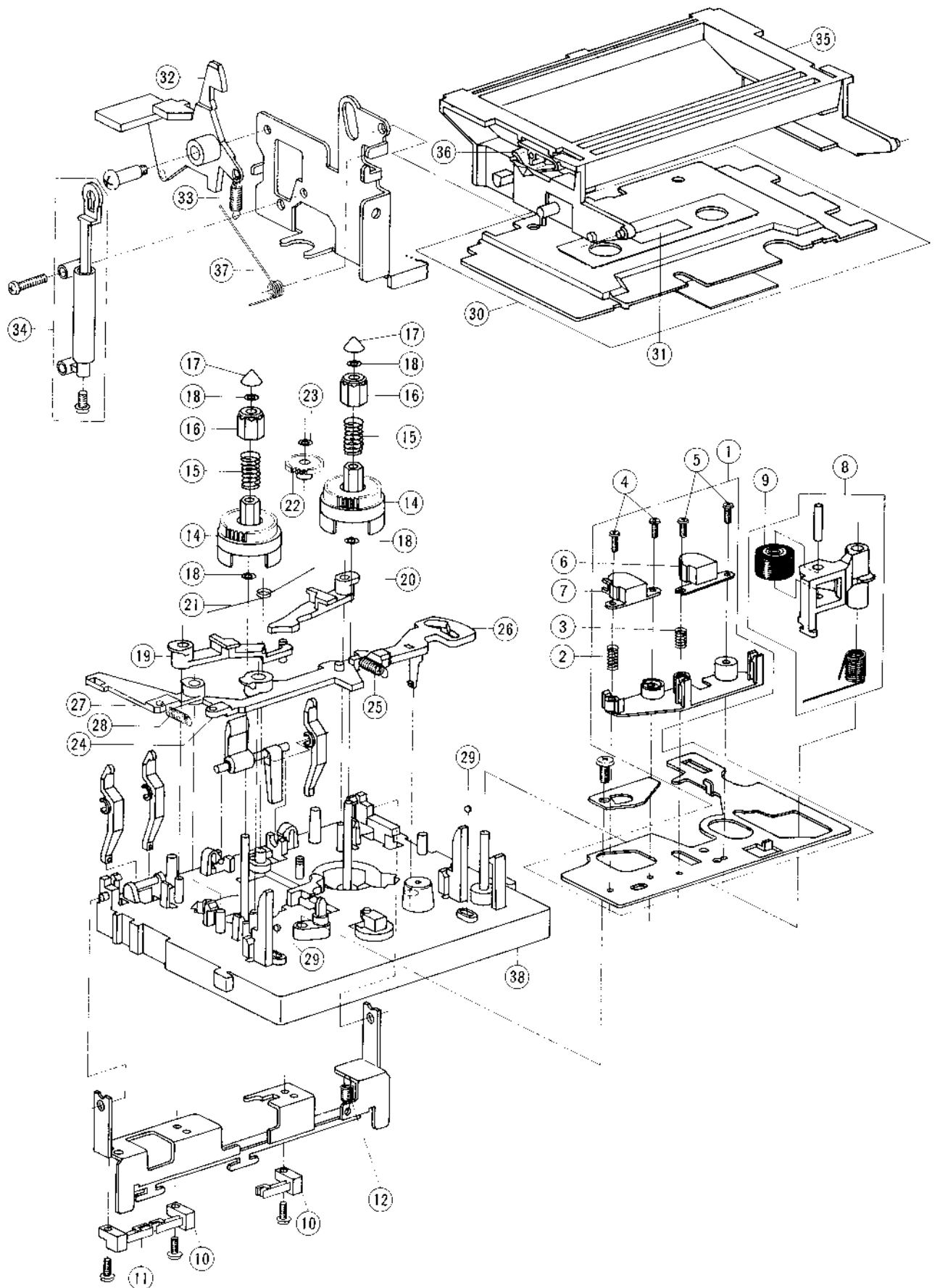

I. MECHA CMS01 BLOCK (1/2)

REF. NO.	PARTS NO.	DESCRIPTION
HEAD BLOCK		
1-1	BH-T2051A030C	HEAD BLK FD-3
1-2	ZG-343104	SP PUSH EH
1-3	ZG-344900	SP PUSH PB (B)
1-4	ZS-417328	BID23x10STL CMT
1-5	ZS-565211	BID20x10STL NI3
1-6	HP-344252	HEAD R/P HN424977
1-7	HE-337047	HEAD E HJ213270 C
PINCH ROLLER (A) BLOCK		
1-8	BL-T2051A040A	PINCH ROLLER (A) BLK HX-M5
1-9	MP-336153	PINCH ROLLER (A)
HOLDER DETECTION BLOCK		
1-10	ES-344253	SW LEAF MSW-1418J 01-1 NO (SW901, 902)
1-11	ES-344257	SW LEAF MSW-1418L 01-1 NO (SW903)
1-12	ZG-312995	SP T1-4.0/0.4-11.2 T1-108
MECHA CMS01 BLOCK		
1-13x	BB-T2051A020C	MECHA CMS01 BLK FD-3
1-14	MT-344187	REEL TABLE
1-15	ZG-344188	SP PUSH REEL TABLE
1-16	MT-344190	REEL RETAINER
1-17	MT-305793	REEL CAP
1-18	ZW-305546	PW21x040x025PSL
1-19	ML-344191	LEVER BRAKE (L)
1-20	ML-344192	LEVER BRAKE (R)
1-21	ZG-344194	SP TORSION BRAKE
1-22	MZ-344906	GEAR FF (B)
1-23	ZW-343120	PW17x040x025PSL
1-24	ML-344196	LEVER (A)
1-25	ZG-344200	SP PULL HEAD CHASSIS
1-26	ML-344197	LEVER (B)
1-27	ML-344743	LEVER EJECT STOPER (B)
1-28	ZG-312923	SP T1-3.2/0.2-11.2 T1-040
1-29	MV-357208	BALL200STL
1-30	BD-B344206B	LID DECORATION (B) PART
1-31	ED-344244	D LED SLF601C UMBER
1-32	ML-344742	LEVER EJECT (B)
1-33	ZG-312925	SP T1-3.2/0.2-14.0 T1-042
1-34	MZ-344297	DUMPER ASSY
1-35	SE-344239	LID HOLDER
1-36	ZG-336615	SP PLATE CASSETTE HOLDER (B)
1-37	ZG-344240	SP TORSION LID HOLDER
1-38	MZ-B344179	MECHA CHASSIS PART

MECHA CMS01 BLOCK (2/2)

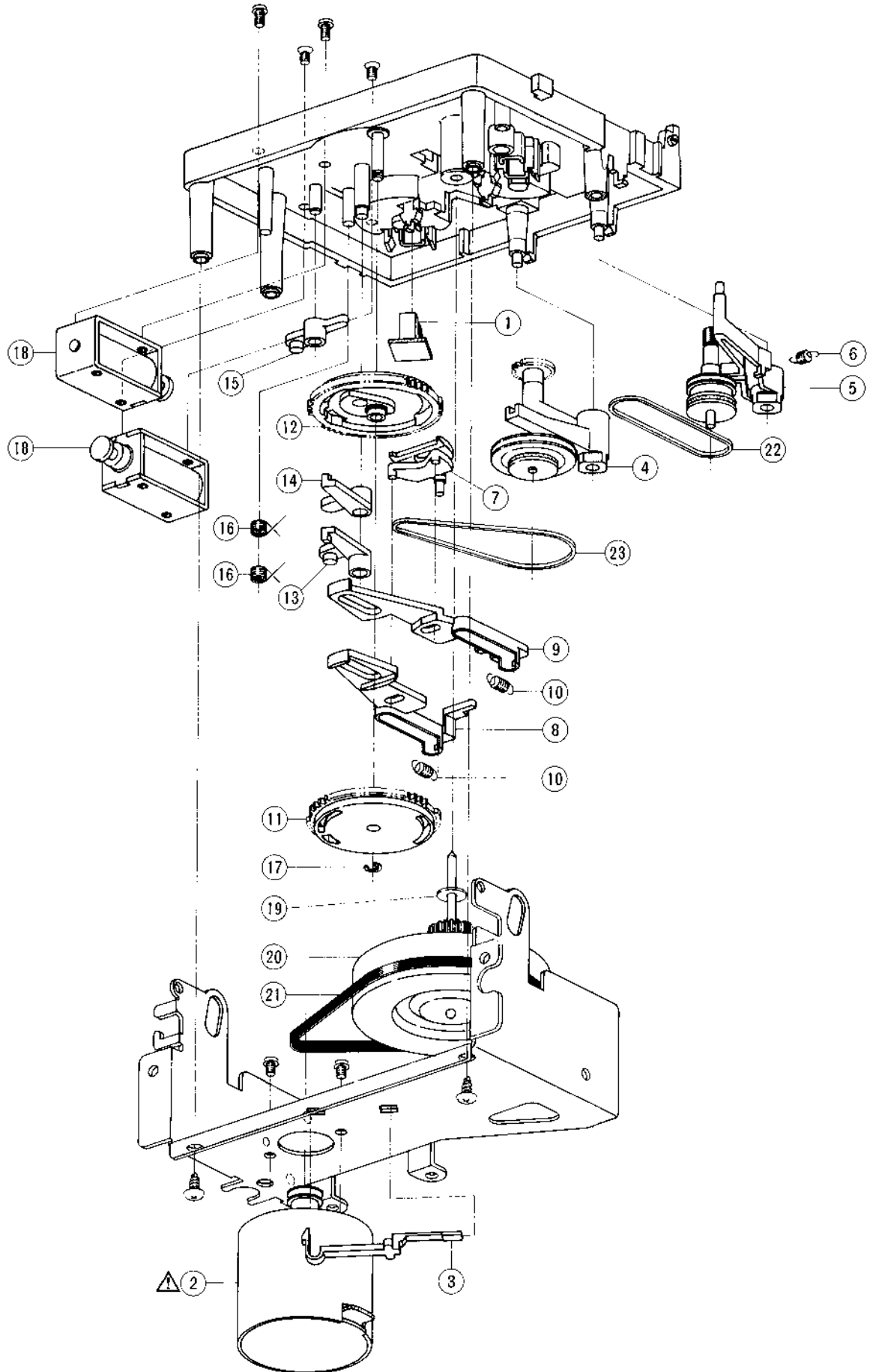

2. MECHA CMS01 BLOCK (2/2)

REF. NO.	PARTS NO.	DESCRIPTION
2-1	ET-311977	PHOTO SENSOR SPI-201
		HOLDER MOTOR BLOCK
2-2	BM-B314815	△ MOTOR (PULLEY) PART HX-M5 (M901)
2-3	TC-344901	HOLDER THRUST
		MECHA CMS01 BLOCK
2-4	MI-B344207	ARM IDLER FR PART
2-5	MI-B344215	ARM IDLER TU PART
2-6	ZG-343152	SP PULL TU IDLER
2-7	TC-344219	CAM SHIFTER
2-8	SK-344220	SLIDE (F)
2-9	TC-344221	SLIDE (R)
2-10	ZS-343153	SP PULL SLIDE
2-11	TP-344222	CAM (F)
2-12	TP-344223	CAM (R)
2-13	TC-344224	ARM LOCK (F)
2-14	TC-344225	ARM LOCK (R)
2-15	TC-344226	ARM JOINT
2-16	ZG-344227	SP TORTION PLUNGER
2-17	ZW-340648	RING CS190STL PKR
2-18	EP-344251	SOLENOID 0730PLT 12V (SL901, 902)
2-19	ZW-345389	PW26×080×020NYL
2-20	MI-B344228	FLYWHEEL PART
2-21	MB-344230	BELT 3.0×0.5T×D61 CR HS60
2-22	MB-344231	BELT 1.0×D33.3 CR HS60
2-23	MB-344905	BELT 1.2×D38.2 CR HS60

3. MAIN P.C BOARD BLOCK

REF. NO.	PARTS NO.	DESCRIPTION
3-1U	BA-C1003A040A	PC MAIN BLK FD-3 (U)
3-1C	BA-C1003A040B	PC MAIN BLK FD-3 (C) (C,A)
3-1E	BA-C1003A040C	PC MAIN BLK FD-3 (E) (E,S)
3-1V	BA-C1003A040D	PC MAIN BLK FD-3 (V)
MAIN AMP P.C BOARD		
3-IC1	EI-337228	IC M5218L0
3-IC2	EI-343371	IC TC9154P
3-IC3	EI-337228	IC M5218L0
3-IC4	EI-346122	△ IC STK4833
3-IC5	EI-322599	IC TA75458S
3-TR1	ET-307195	TR 2SC2240 GR,BL
3-TR2	ET-322778	TR 2SA608K-NP E,F,G
3-TR4	ET-322775	TR 2SC536K-NP E,F,G
3-TR5	ET-322775	△ TR 2SC536K-NP E,F,G
3-TR6	ET-452531	△ TR 2SD313HP E,F
3-TR7	ET-318239	△ TR 2SD863 E,F
3-TR8	ET-318237	△ TR 2SB764 E,F
3-TR11	ET-452531	△ TR 2SD313HP E,F
3-TR12	ET-310148	△ TR 2SD612K E,F
3-TR13	ET-301165	△ TR 2SB631K E,F
3-TR14	ET-310148	△ TR 2SD612K E,F
3-D1,2	ED-343410	D ZENER H HZ6L A1
3-D3,4	ED-301911	D SILICON H DS448
3-D6	ED-345149	D ZENER H HZ15L 3
3-D7	ED-346574	△ D ZENER H HZ22L 2
3-D8,9	ED-345149	△ D ZENER H HZ15L 3
3-D10	ED-200213	△ D SILICON DBA40C-K15 200/2.6A
3-D11	ED-348200	△ D SILICON DBA20C-K15 200/20A
3-D12	ED-301911	△ D SILICON H DS448
3-D13	ED-307690	D ZENER H HZ7L A1
3-D14	ED-330320	△ D SILICON DBA10C 200/1.0A
3-D15	ED-346583	D ZENER H HZ30L 3
3-D16	ED-307690	D ZENER H HZ7L A1
3-D17	ED-330320	△ D SILICON DBA10C 200/1.0A
3-D18	ED-224526	△ D SILICON 10D1 100/1.0A
3-D19	ED-347963	D ZENER H 1Z6.2
3-D20	ED-346583	D ZENER H HZ30L 3
3-D21	ED-345149	D ZENER H HZ15L 3
3-SW1	ES-347616	SW PUSH J-K1121#01 2THROW
3-VR1	EV-347614	VR ROTARY 16P20x3B C104
3-VR2	EV-347615	VR ROTARY 16P20x3A C104
3-L1	EO-337880	COIL FIX 2 202AK-018 2.20μH
3-L3	EO-336934	COIL FIX 1 LAL03KH 2.20μH (V)
3-FR1	ER-341920	△ R FUSE ERQ14AJ S10 1/4W 101J
3-FR2,3	ER-328278	△ R FUSE ERD2FC 1/4W 10R0G
3-R11,12	ER-323074	△ R CB H S10 FS RDS 1/4W 102J
3-R36	ER-200940	△ R CB H S10 FS RDS 1/4W 561J
3-R40	ER-311685	△ R CB H S15 FS RDS 1/2W 4R7J
3-R43	ER-321153	△ R OMF H S15 FS 1W 102J
3-R49	ER-308028	△ R OMF H S15 FS 1W 181J
3-R52	ER-324934	△ R CB H S10 FS RDS 1/4W 220J
3-R55	ER-322787	△ R CB H S10 FS RDS 1/4W 100J
3-R71	ER-328067	△ R CB H S10 FS RDS 1/4W 331J
3-R73	ER-322787	△ R CB H S10 FS RDS 1/4W 100J
3-R75	ER-333625	△ R CB H S15 FS RDS 1/2W 180J
3-R76	ER-333429	R CB H S10 FS RDS 1/4W 682J
3-R77	ER-322787	R CB H S10 FS RDS 1/4W 100J
3-C29	EC-343855	C EC V F05 NP SM R22M 50.0DC
3-C33	EC-345605	C EC V S10 682M 45.0DC
3-C36	EC-345605	C EC V S10 682M 45.0DC
3-C37	EC-326583	C MMY V CUT CF921 473K 400DC

REF. NO.	PARTS NO.	DESCRIPTION
SPEAKER P.C BOARD		
3-TM1	EI-343378	TERMINAL PUSH SQ-2783#90 P 8P
3-L4	EO-342936	COIL BALUN (V)
MIC P.C BOARD		
3-J8	EJ-347618	PHONE JACK JL3A 9P
3-L5	EO-338420	COIL FIX 2 FL12R202E 2.00MH (V)
HEADPHONE P.C BOARD		
3-J9	EJ-347619	PHONE J 3P HJ0606-20 6.3
PLAYER P.C BOARD		
3-J10	EJ-347474	SOCKET POWER M1674 6P
3-F4U	EF-306950	△ FUSE TSC A 250V 2.00A (U)
3-F4C	EF-306954	△ FUSE TSC 125V 2.00A (C,A)
3-F4E	EF-601301	△ FUSE SEMKO T 250V 2.00A (E,B,S,V)
3-F5U	EF-306950	△ FUSE TSC A 250V 2.00A (U)
3-F5C	EF-306954	△ FUSE TSC 125V 2.00A (C,A)
3-F5E	EF-601301	△ FUSE SEMKO T 250V 2.00A (E,B,S,V)
3-F6U	EF-309387	△ FUSE TSC A 250V 1.00A (U)
3-F6C	EF-310229	△ FUSE STS 125V 1.00A (C,A)
3-F6E	EF-623103	△ FUSE SEMKO T 250V 1.00A (E,B,S,V)
3-F7U	EF-327103	△ FUSE TSC A 250V 0.50A (U)
3-F7C	EF-309390	△ FUSE TSC 125V 0.50A (C,A)
3-F7E	EF-593706	△ FUSE SEMKO T 250V 0.50A (E,B,S,V)
3-F8U	EF-306951	△ FUSE TSC A 250V 2.50A (U)
3-F8C	EF-306956	△ FUSE TSC 125V 2.50A (C,A)
3-F8E	EF-601301	△ FUSE SEMKO T250V 2.00A (E,B,S,V)
3-F9U	EF-306951	△ FUSE TSC A 250V 2.50A (U)
3-F9C	EF-306956	△ FUSE TSC 125V 2.50A (C,A)
3-F9E	EF-601301	△ FUSE SEMKO T 250V 2.00A (E,B,S,V)

4. PRE AMP P.C BOARD BLOCK

REF. NO.	PARTS NO.	DESCRIPTION
4-1	BA-C1003A050A	PC PRE AMP BLK FD-3
4-IC2	EI-344291	IC NE654
4-IC3	EI-337835	IC NE652
4-TR1	ET-344275	TR 2SC2320L F,G
4-TR2	ET-308141	TR 2SC2603 G
4-TR3	ET-200985	TR 2SC2603 F,G
4-TR4	ET-200505	TR 2SC2603 E,F
4-TR5	ET-328578	TR 2SC2320 E,F
4-TR8	ET-332421	TR 2SD1010 R,S
4-TR9	ET-201580	TR 2SD894
4-TR10	ET-328437	TR 2SD1012-V F,G
4-TR11to17	ET-328578	TR 2SC2320 E,F
4-TR18to20	ET-200558	TR 2SA1115 E,F
4-TR22,23	ET-200505	TR 2SC2603 E,F
4-TR24	ET-318239	TR 2SD863 E,F
4-TR25,26	ET-310833	TR 2SC2274K E
4-TR28to30	ET-200505	TR 2SC2603 E,F
4-TR31	ET-337258	TR 2SC1843 E,F
4-TR32	ET-344275	TR 2SC2320L F,G
4-TR33	ET-328578	TR 2SC2320 E,F
4-TR34	ET-200985	TR 2SC2603 F,G
4-D1	ED-337575	D SILICON H GMA-01-4-BT T26
4-D2to4	ED-301911	D SILICON H DS448
4-D6	ED-346286	D ZENER V HZ3C-3S1
4-D8	ED-301911	D SILICON H DS448
4-D9	ED-308952	D GERMA V 1K34A-LR F07
4-D13	ED-337575	D SILICON H GMA-01-4-BT T26
4-VR1	EV-315414	R S-FIX H D8 3P 203
4-VR2	EV-322413	R S-FIX H D8 3P 302
4-VR3	EV-315416	R S-FIX H D8 3P 103
4-VR4	EV-336785	R S-FIX H TM8KV2-1S 3P 0.50W 104
4-VR5	EV-315413	R S-FIX H D8 3P 503
4-RL1	EP-337067	RELAY LEAD LAB2NS 2NO 18V
4-L2	EO-347162	COIL FIX 1 L-8 10MHZ J
4-FR1,2	ER-307565	Δ R FUSE ERD2FC S10 1/4W 6R8J
4-C13	EC-314992	C STY V F05 CQF09 681J 50DC
4-C45	EC-306022	C STY V F05 CQ09S 821J 50DC
4-C58	EC-307725	C PP V ECQ-P 103J 100DC
4-C59	EC-337777	C PP V F10 ECQ-F 272J 630DC
4-C61	EC-307494	C STY V F05 CQ09S 331J 50DC
4-C63	EC-302265	C STY V F05 CQF09 271J 50DC
4-C67	EC-314990	C STY V SNP CQFS 101J 50DC
4-T1	EO-337774	COIL OSC 1 0365-056 100.0KHZ
4-FL1	ER-337695	FILTER DB 201AK-005 100KHZ
4-FL3	EO-336738	COIL TUN 1 102AK-004 19.80KHZ
4-FL5	EO-315758	COIL TUN 1 100S-431 100.00KHZ

5. CONTROL P.C BOARD BLOCK

REF. NO.	PARTS NO.	DESCRIPTION
5-1U	BA-C1003A070A	PC CONTROL BLK FD-3 (U)
5-1C	BA-C1003A070B	PC CONTROL BLK FD-3 (C) (C,A)
5-1E	BA-C1003A070C	PC CONTROL BLK FD-3 (E) (E,S,V)
5-1LE	BA-C1003A070D	PC CONTROL BLK FD-3L (E)
5-1LB	BA-C1003A070E	PC CONTROL BLK FD-3L (B)

CONTROL P.C BOARD

5-IC1	EI-347454	IC TC47C21P MH-100
5-IC1N	EI-346965	IC TC47C21P NH-101
5-IC2	EI-347455	IC TC47C20P NH-200
5-IC2N	EI-346966	IC TC47C20P NH-201
5-IC3	EI-344277	IC LM6405H-145
5-IC4	EI-332287	IC M54517P
5-IC5	EI-338171	IC LC4069UB
5-IC6	EI-315379	IC TC5066BP
5-IC7	EI-332258	IC M54516
5-IC8	EI-338171	IC LC4069UB
5-IC9	EI-330226	IC UPC1373H
5-IC10to12	EI-336794	IC LB1240
5-TR1to3	ET-200558	TR 2SA1115 E,F
5-TR4,5	ET-338081	TR 2SB774 R,S
5-D1	ED-301911	D SILICON H DS448
5-D2,4	ED-200469	D SILICON H DS448 FA5 F10
5-D5	ED-224526	D SILICON 10D1 100/1.0A
5-D6to15	ED-301911	D SILICON H DS448
5-D27	ED-3474149	D ZENER H 05Z8.2 Y
5-D28	ET-330717	PHOTO SENSOR NJL1644L
5-L1	EO-330719	COIL FIX 1 187LY-103K 10.00MH K

5-L2	EO-336934	COIL FIX 1 LAL03KH 2.20UH M
5-X1,2	EI-347434	OSC X'TAL HC-18/U 4.194304MHZ
5-X3	EI-337017	OSC CE CSB800A 0.800000MHZ
5-R48	ER-328067	Δ R CB H S10 FS RDS 1/4W 331J

5-SR1	ER-347437	R COMP EXB-P88 104K
5-SR2	ER-347438	R COMP EXB-P87104K
5-SR3	ER-343420	R COMP EXB-P84104K
5-SR4	ER-347688	R COMP EXB-P88 472K
5-SR5	ER-347164	R COMP RKC 1/8 B8 223J
5-SR6	ER-347164	R COMP RKC 1/8 B8 223J
5-TC1	EC-330692	C S-FIX H TZ03R200E 4.2-20

FLD P.C BOARD

5-SW1to5	ES-336780	SW TACT KHH10902
5-IND1	EM-347469	IND FL BG-142Z DOUBLE

TIMER SELECTOR P.C BOARD

5-SW6,7	ES-336780	SW TACT KHH10902
5-SW9	ES-347436	SW ROTARY SRM1017 1-01-07S
5-SW11,12	ES-347966	SW PUSH ESB-649 01-2-2 N
5-D23	ED-200469	D SILICON H DS448 FA5 F10 (C,B)

TIMER P.C BOARD

5-SW8	ES-336780	SW TACT KHH10902
-------	-----------	------------------

LAMP P.C BOARD

5-LP1to4	EL-347456	PL MINI BASE 14.0V 50MA
----------	-----------	-------------------------

BEAT CANCEL P.C BOARD

5-SW10	ES-344439	SW SLIDE 00420451 2-04-02
5-C23	EC-346689	C STY V S05 CQFS 471J 250DC

6. TUNER P.C BOARD BLOCK

REF. NO.	PARTS NO.	DESCRIPTION
6-1U	BA-C1002A090A	PC TUNER BLK FD-7 (U)
6-1C	BA-C1002A090B	PC TUNER BLK FD-7 (C) (C,A)
6-1E	BA-C1002A090C	PC TUNER BLK FD-7 (E)
6-1V	BA-C1002A090D	PC TUNER BLK FD-7 (V)
6-1S	BA-C1002A090E	PC TUNER BLK FD-7 (S)
6-1LE	BA-C1002A090F	PC TUNER BLK FD-7L (E)
6-1LB	BA-C1002A090G	PC TUNER BLK FD-7L (B)
6-IC1	EI-322248	IC LA1231N
6-IC2	EI-343349	IC LA3390
6-IC3	EI-202218	IC LA1245
6-IC4	EI-315381	IC TD6102P
6-IC5	EI-336717	IC TC9125BP
6-TR1	ET-336935	TR 2SC3000 E,F
6-TR2	ET-332311	TR 2SA608SP D,E,F,G
6-TR3	ET-338410	TR 2SC2878 A,B (L ONLY)
6-TR4to6	ET-322778	TR 2SA608K-NP E,F,G(L ONLY)
6-TR7	ET-337604	TR FET 2SK246 Y (L ONLY)
6-TR9	ET-322775	TR 2SC536K-NP E,F,G(L ONLY)
6-TR10	ET-330588	TR FET 2SK19 O,Y (L ONLY)
6-TR11,12	ET-322775	TR 2SC536K-NP E,F,G(L ONLY)
6-TR13,14	ET-246846	TR 2SC536NP E,F,G,H
6-TR16	ET-246846	TR 2SC536NP E,F,G,H
6-TR17	ET-322778	TR 2SA608K-NP E,F,G
6-TR18	ET-246846	TR 2SC536NP E,F,G,H
6-TR19	ET-336937	TR FET 2SK223 E,F
6-TR20	ET-246846	TR 2SC536NP E,F,G,H
6-TR21	ET-330464	TR 2SC2603 D,E
6-TR22	ET-246846	TR 2SC536NP E,F,G,H
6-TR24	ET-200505	TR 2SC2603 E,F (V ONLY)
6-D1	ED-337575	D SILICON H GMA-01-4-BT T26
6-D2	ED-344280	D SILICON H GMA-01-FY2F05 (L ONLY)
6-D3	ED-348205	D SILICON V MC931 DOUBLE (L ONLY)
6-D4,5	ED-337575	D SILICON H GMA-01-4-BT T26
6-D7,8	ED-337605	D VARACTOR SVC333 (A) DOUBLE
6-D9	ED-348205	D SILICON V MC931 DOUBLE
6-D10	ED-337575	D SILICON H GMA-01-4-BT T26
6-SW1	ES-344445	SW TACT EVQ-QHR12B
6-SW2	ES-344439	SW SLIDE 00420451 2-04-02 (U)
6-VR1	EV-337993	R S-FIX H RVF8P01 3P 203
6-VR2	EV-337995	R S-FIX H RVF8P01 3P 103
6-L1	EO-345904	COIL FIX 1 LAL03KH 1.50μH M
6-T1	EO-336878	COIL DET 2 78-1049
6-T2	EO-336879	COIL DET 2 78-1050
6-T3	EO-337598	COIL VARI 2 25A-1353-01
6-T4	EO-337599	COIL VARI 2 25A-1354-03 (L ONLY)
6-T5	EO-202215	COIL OSC 2 7NR-6721Y 100.0μH
6-T6	EO-307786	COIL OSC 2 7NR-6722Y 580.0μH (L ONLY)
6-T7	EO-343351	COIL IFT PEGK00008B-01 455.0KHz
6-T8	EO-202216	COIL IFT 7MC-6733C 460.0KHz
6-FL1U	ER-315407	FILTER CE SFE10.7MMKA 10.7MHZ (EXCEPT L,E)
6-FL1L	ER-345729	FILTER CE SFE10.7MZ1KA 10.7MHZ (L,E ONLY)
6-FL2U	ER-336804	FILTER CE SFE10.7MA8 10.7MHZ (EXCEPT V,E)
6-FL2L	ER-338338	FILTER CE MS3GKY-A 10.700MHZ (V,E)
6-FL3	ER-341654	FILTER LC LP 42W-1001
6-FL4U	ER-343352	FILTER CE SFU459B9 0.459MHZ (EXCEPT C)
6-FL4C	ER-343353	FILTER CE SFU460B9 0.460MHZ (C)
6-FL5U	ER-337327	FILTER CE BFU459C4N 0.459MHZ (EXCEPT C)
6-FL5C	ER-337328	FILTER CE BFU460C4N 0.46MHZ (C)
6-FL6V	ER-336830	FILTER LC LP BL-34HD (V)
6-X1	EI-327074	OSC X TAL HC-18/U 9.000000MHZ

REF. NO.	PARTS NO.	DESCRIPTION
6-VC1to3	EC-330692	C S-FIX H TZ03R200E 4.2-20
6-R7	ER-324184	R CB H S10 FS RDS 1/4W 121J
6-R15	ER-324337	R CB H S10 FS RDS 1/4W 560J
6-R20to22	ER-324337	R CB H S10 FS RDS 1/4W 560J
6-R63	ER-324185	R CB H S10 FS RDS 1/4W 221J
6-R65	ER-324184	R CB H S10 FS RDS 1/4W 121J
6-R92,93	ER-324480	R CB H S10 FS RDS 1/4W 470J
6-R107	ER-324480	R CB H S10 FS RDS 1/4W 470J
6-R113	ER-324934	R CB H S10 FS RDS 1/4W 220J
6-R114	ER-324184	R CB H S10 FS RDS 1/4W 121J
6-C25U	EC-344486	C PP V F05 PP 391J 50DC (EXCEPT C)
6-C25C	EC-344478	C PP V F05 PP 561J 50DC (C)
6-C26U	EC-344486	C PP V F05 PP 391J 50DC (EXCEPT C)
6-C26C	EC-344478	C PP V F05 PP 561J 50DC (C)
6-C27,28	EC-344482	C PP V F05 PP 161J 50DC (U)
6-C36	EC-344483	C PP V F05 PP 102J 50DC
6-C42	EC-344481	C PP V F05 PP 4700G 50DC
6-C43	EC-344482	C PP V F05 PP 161J 50DC (L ONLY)
6-2	TA-347458	FRONT END FE391U13 88-108MHZ (EXCEPT V)
6-2V	TA-347459	FRONT END FE393E12 88-108MHZ (V)
6-TM1	EJ-344423	TERMINAL W/SCREW YKD31-0133 P 2P

7. FUNCTION P.C BOARD BLOCK

REF. NO.	PARTS NO.	DESCRIPTION
7-IC1	EI-344764	IC M5218P-21
7-IC2	EI-332259	IC TC4052BP
7-D1,2	ED-307690	D ZENER H HZ7L A1
7-J1	EJ-336904	PIN J AJC-036-ACB P 6P
7-L1	EO-338420	COIL FIX 2 FL12R202E 2.00MH (V)
7-L2,3	EO-336934	COIL FIX 1 LAL03KH 2.20UH M (V)
7-R20,21	ER-323074	Δ R CB H S10 FS RDS 1/4W 102J
7-1	EJ-329610	TERMINAL W/SCREW UB-0067 L 1P

8. POWER SUPPLY P.C BOARD BLOCK

REF. NO.	PARTS NO.	DESCRIPTION
POWER SUPPLY P.C BOARD		
8-D1	ED-2000469	D SILICON DS448 FA5 F10
8-SW1A	ES-337902	SW PUSH SDLD1P 01-1
8-RL1A	EP-347611	△ RELAY POWER G2R-1112PFD-V 1NO 12V
8-FL1	EO-338409	COIL LF FKOB160MH02 250μH (V ONLY)
8-C1U	EC-320548	△ C CE V F 103Z 250AC (U)
8-C1C	EC-314688	△ C CE V FZ 103P 125AC (C,A)
8-C1E	EC-338577	△ C CE V F 472M 400AC(E,V,S)
8-C2U	EC-320548	△ C CE V F 103Z 250AC (U)
8-C2C	EC-314688	△ C CE V FZ 103P 125AC (C,A)
8-C2E	EC-338577	△ C CE V F 472M 400AC(E,V,S)
VOLTAGE SELECTOR P.C BOARD		
8-SW1B	ES-348463	SW SLIDE X012B11Y 01-2 (U ONLY)
8-SW2B	ES-347617	△ SW SELECTOR 0240#02 01-4 (U ONLY)
8-F1U	EF-309387	△ FUSE TSC A 250V 1.00A (U)
8-F1C	EF-310229	△ FUSE TSC 125V 1.00A (C,A)
8-F1E	EF-623103	△ FUSE SEMKO T 250V 1.00A (E,B,S,V)
8-F2U	EF-306950	△ FUSE TSC A 250V 2.00A (U)
8-F2C	EF-306957	△ FUSE TSC 125V 4.00A (C,A)
8-F2E	EF-601301	△ FUSE SEMKO T 250V 2.00A (E,B,S,V)
8-F3U	EF-306950	△ FUSE TSC A 250V 2.00A (U)

9. CONNECTOR P.C BOARD BLOCK

REF. NO.	PARTS NO.	DESCRIPTION
9-D1,2	ED-323979	D SILICON W03B F12 100/1.0A
9-D3,4	ED-200469	D SILICON H DS448 FA5

CHASSIS FRONT BLOCK

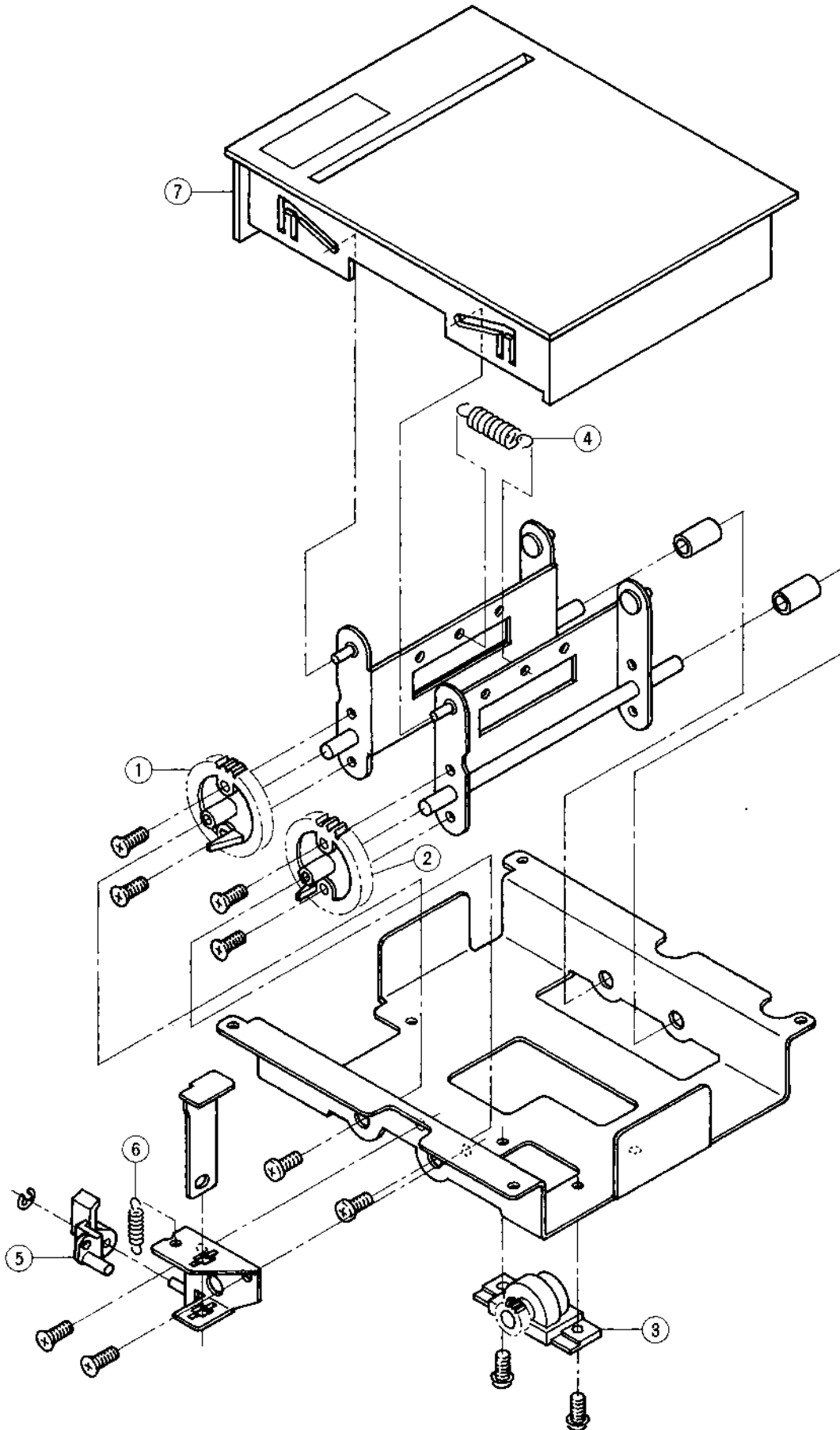

10. CHASSIS FRONT BLOCK

REF. NO.	PARTS NO.	DESCRIPTION
10-1	MZ-344850	GEAR TRANSFER (A)
10-2	MZ-347146	GEAR TRANSFER (B)
10-3	MZ-347620	DUMPER ASSY 3734-A-A-999-02
10-4	ZG-348994	SP PULL REMOCON TRANSFER
10-5	MZ-344853	CAM STOPPER
10-6	ZG-312943	SP T1-3.2/0.29-11.2 T1-059
10-7	SE-344873	ESCUTCHEON TRANSFER
10-7P	SE-344873B	ESCUTCHEON TRANSFER-P

11. REMOTE CONTROL BLOCK

REF. NO.	PARTS NO.	DESCRIPTION
11-1	AX-347598	REMOCON UNIT SFA10A001
11-1P	AX-349153	REMOCON UNIT SFA10A001 NEW
11-2	SP-749998	COVER BATTERY FD-3
11-2P	SP-749999	COVER BATTERY FD-3-P
11-3	TA-344883	STATION CARDS (EXCEPT L-B)
11-4	TA-344883B	STATION CARDS (B) (L-B ONLY)
11-IC201	EI-749983	IC UPD1943G
11-Q01	ET-302502	TR 2SC2001 K
11-Q02	ET-398788	TR 2SC945L R
11-LED01,02	ED-705414	D LED SE303A INFRARED
11-LED03	ED-322247	D LED SLP151D RED
11-SL-SW	ES-749947	SW SLIDE
11-S01to15	ES-336780	SW TACT KHH10902
11-S17to28	ES-336780	SW TACT KHH10902
11-X01	EH-749948	FILTER CE CSB455C

ASSEMBLY BLOCK

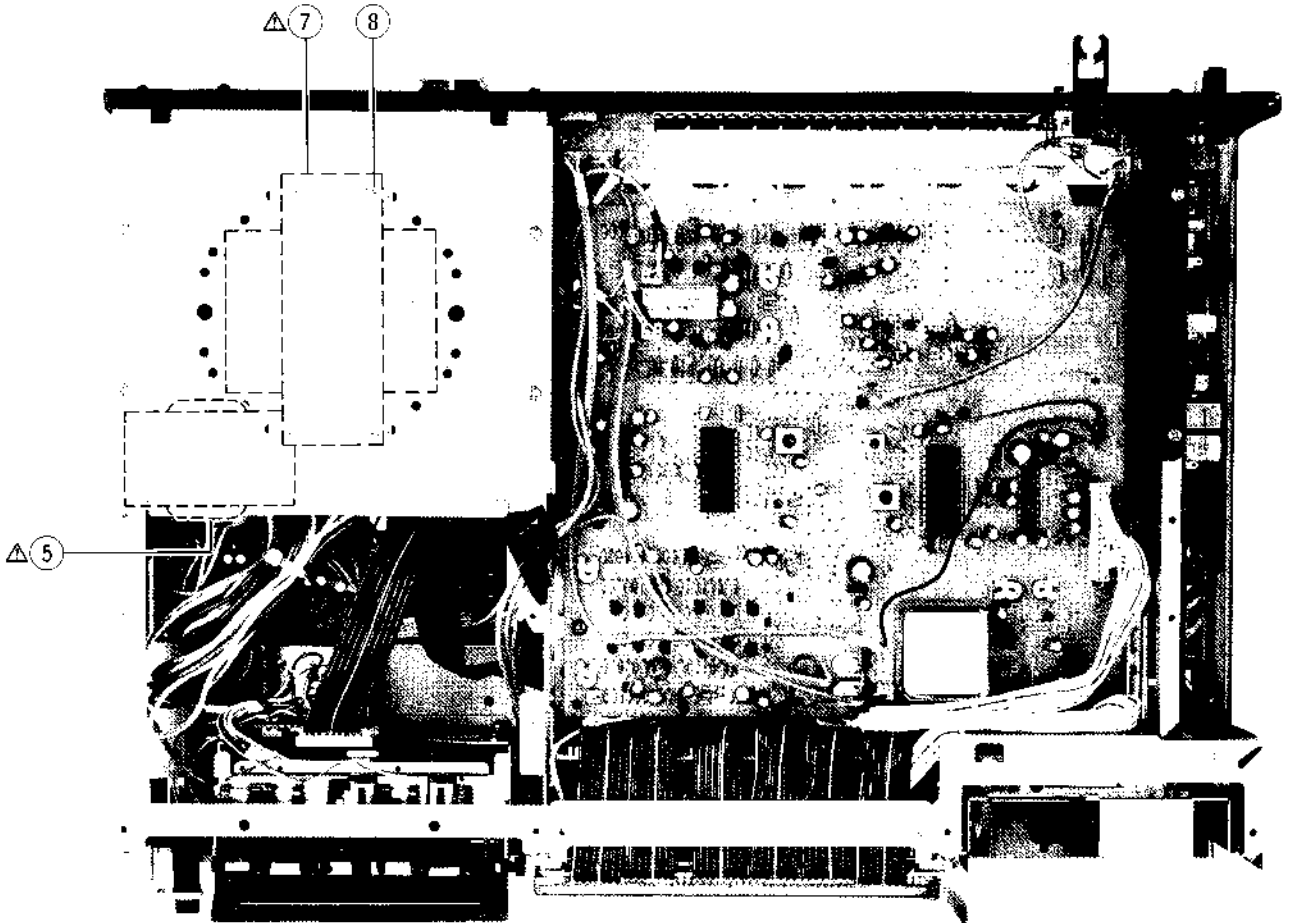
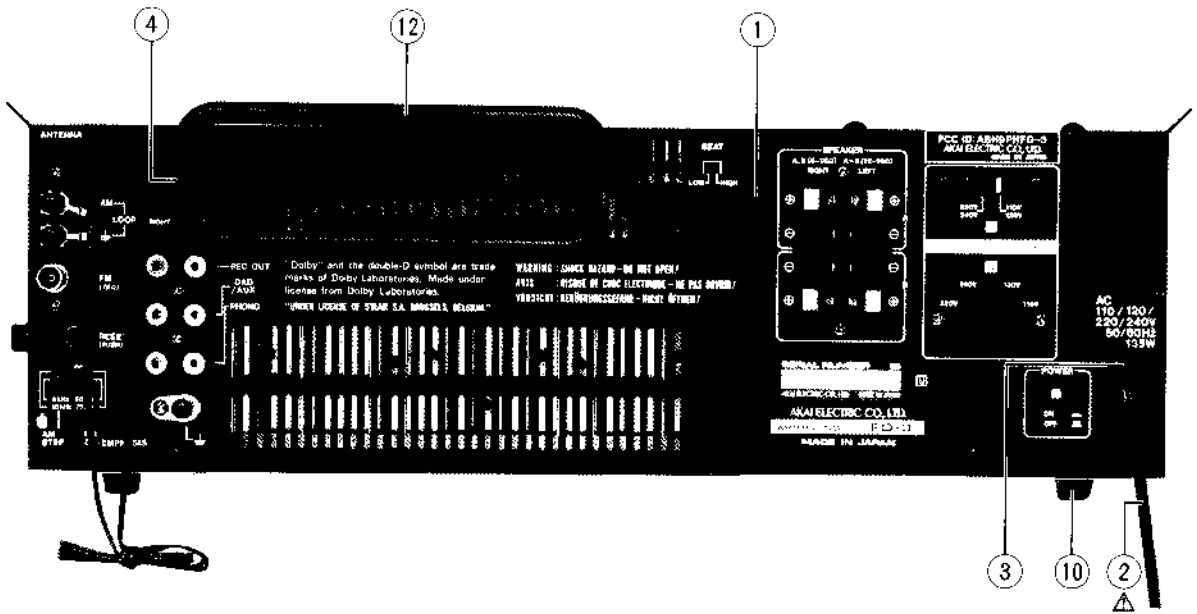

12. ASSEMBLY BLOCK

REF. NO.	PARTS NO.	DESCRIPTION
12-1U	SP-344875G	PANEL REAR (A) FD-3 (U)
12-1C	SP-344875H	PANEL REAR (B) FD-3 (C,A)
12-1E	SP-344875J	PANEL REAR (B) FD-3 (E,V)
12-1S	SP-344875K	PANEL REAR (B) FD-3 (S)
12-1LE	SP-344875L	PANEL REAR (B) FD-3L (E)
12-1LB	SP-344875M	PANEL REAR (B) FD-3L (B)
12-2U	EW-306428	△ AC CORD 2 CORES KP-205A, VFF U/T (U)
12-2C	EW-343363	△ AC CORD 2 CORES KP-8, SPT-2 105C UC (C)
12-2A	EW-305691	△ AC CORD 2 CORES KP-8, SPT-1 UC (A)
12-2E	EW-336923	△ AC CORD 2 CORES KP-419C, LTCE-2F EV (E,V)
12-2S	EW-336924	△ AC CORD 2 CORES KP-560, LTSA-2F S (S)
12-2B	EW-347025	△ AC CORD 2 CORES LTBS-2F B (B)
12-3	EZ-631945	STRAIN RELIEF SR-4N-4
12-4	SZ-332739	HOLDER ANTENNA
12-5U	BT-347690	△ TRANS POWER C1003T2-72 (U)
12-5C	BT-34691	△ TRANS POWER C1003T2-32 (C,A)
12-5E	BT-347692	△ TRANS POWER C1003T2-42 (E,V)
12-5S	BT-347693	△ TRANS POWER C1003T2-52
12-6x	ZS-315511	ST PAN30x06STL CMT CUP
12-7U	BT-347592	△ TRANS POWER C1003-F71 (U)
12-7C	BT-347593	△ TRANS POWER C1003-F31 (C)
12-7A	BT-347594	△ TRANS POWER C1003-F21 (A)
12-7E	BT-347595	△ TRANS POWER C1003-F41 (E,V)
12-7S	BT-347596	△ TRANS POWER C1003-F51 (S,B)
12-8	ZS-301398	ST BID40x08STL CMT
12-9x	ML-344857	JOINT
12-10	SA-347145	FOOT
12-11x	ZS-344914	ST PAN30x12STL CMT CUP
12-12	EE-337976	ANT LOOP LA-200A
12-13x	ZW-305013	RV POP32 (A)

FINAL ASSEMBLY BLOCK

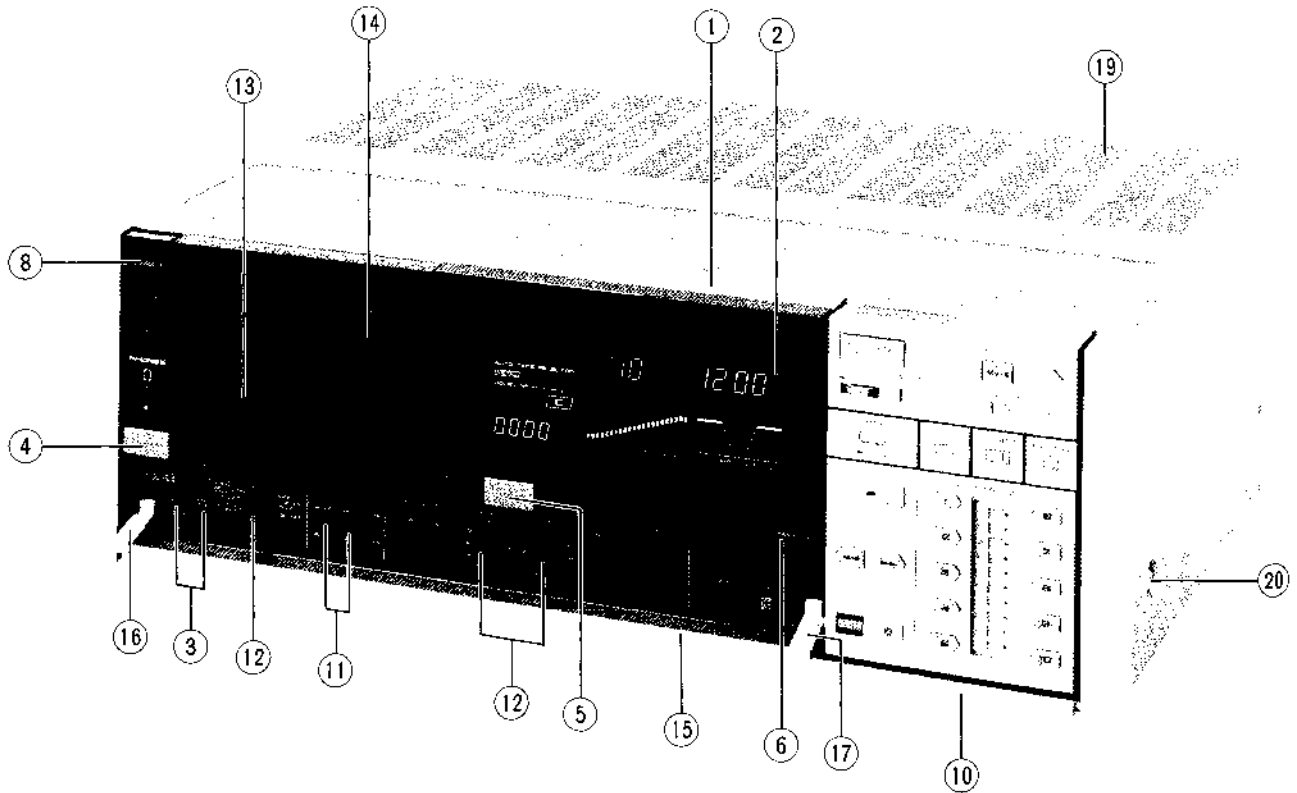

13. FRONT PANEL BLOCK

REF. NO.	PARTS NO.	DESCRIPTION
FRONT PANEL BLOCK		
13-1	BD-C1003A060A	PANEL FRONT BLK FD-3
13-1P	BD-C1003A060B	PANEL FRONT BLK FD-3-P
13-2	SE-344863	WINDOW FLD
13-3	SK-344871	KNOB (4)-B
13-4	SK-344868A	KNOB (2)-A
13-4P	SK-344868F	KNOB (2)-A-P
13-5	SK-344868C	KNOB (2)-C
13-5P	SK-344868H	KNOB (2)-C-P
13-6	SK-344868E	KNOB (2)-E
13-7x	ZG-347622	SP PUSH KNOB (2)
13-8	SK-344869	KNOB (3)
13-9x	ZG-322189	SP (B)
FINAL ASSEMBLY BLOCK		
13-10	SP-344862	SASH FRONT
13-10P	SP-344862B	SASH FRONT-P
13-11	SK-344870	KNOB (4)-A
13-12	SK-332534D	KNOB ROTARY (D)
13-13	BD-344865B	LID FRAME FD-3
13-14	BD-344864	LID
13-15	SP-344872A	PANEL DOOR FD-3
13-15P	SP-344872E	PANEL DOOR FD-3-P
13-15L	SP-344872B	PANEL DOOR FD-3L
13-15LP	SP-344872F	PANEL DOOR FD-3L-P
13-16	TP-344879A	HINGE DOOR PANEL (L)
13-17	TP-344879B	HINGE DOOR PANEL (R)
13-18x	ZS-341962	PT BR23x10STL CMT
13-19	BC-344859	COVER
13-20	ZS-322570	ST BID40x08STL N13

INDEX

PARTS NO.	REF. NO.	PARTS NO.	REF. NO.	PARTS NO.	REF. NO.	PARTS NO.	REF. NO.
AX-347598	11-1	ED-301911	3-D12	EI-202218	6-IC3	ER-322787	3-R61
AX-349153	11-1P	ED-301911	4-D2	EI-315379	5-IC6	ER-322787	3-R69
BA-C1002A090A	6-1U	ED-301911	4-D3	EI-315381	6-IC4	ER-322787	3-R73
BA-C1002A090B	6-1C	ED-301911	4-D4	EI-322248	6-IC1	ER-322787	3-R77
BA-C1002A090C	6-1E	ED-301911	4-D8	EI-322599	3-IC5	ER-323074	3-R11
BA-C1002A090D	6-1V	ED-301911	5-D1	EI-327074	6-X1	ER-323074	3-R12
BA-C1002A090E	6-1S	ED-301911	5-D6	EI-330226	5-IC9	ER-323074	7-R21
BA-C1002A090F	6-1LE	ED-301911	5-D7	EI-332258	5-IC7	ER-323074	7-R20
BA-C1002A090G	6-1LB	ED-301911	5-D8	EI-332259	7-IC2	ER-324184	6-R114
BA-C1003A040A	3-1U	ED-301911	5-D9	EI-332287	5-IC4	ER-324184	6-R65
BA-C1003A040B	3-1C	ED-301911	5-D10	EI-336717	6-IC5	ER-324184	6-R7
BA-C1003A040C	3-1E	ED-301911	5-D11	EI-336794	5-IC10	ER-324185	6-R63
BA-C1003A040D	3-1V	ED-301911	5-D12	EI-336794	5-IC11	ER-324337	6-R22
BA-C1003A050A	4-1	ED-301911	5-D13	EI-336794	5-IC12	ER-324337	6-R21
BA-C1003A070A	5-1U	ED-301911	5-D14	EI-337017	5-X3	ER-324337	6-R15
BA-C1003A070B	5-1C	ED-301911	5-D15	EI-337228	3-IC3	ER-324337	6-R20
BA-C1003A070C	5-1E	ED-307690	3-D13	EI-337228	3-IC1	ER-324480	6-R107
BA-C1003A070D	5-1LE	ED-307690	3-D16	EI-337835	4-IC3	ER-324480	6-R93
BA-C1003A070E	5-1LB	ED-307690	7-D2	EI-338171	5-IC5	ER-324480	6-R92
BB-T2051A020C	1-13x	ED-307690	7-D1	EI-338171	5-IC8	ER-324934	3-R52
BC-344859	13-19	ED-308952	4-D9	EI-343349	6-IC2	ER-324934	6-R113
BD-B344206B	1-30	ED-322247	11-LED03	EI-343371	3-IC2	ER-328067	3-R71
BD-C1003A060A	13-1	ED-323937	9-D2	EI-344277	5-IC3	ER-328067	5-R48
BD-C1003A060B	13-1P	ED-323979	9-D1	EI-344291	4-IC2	ER-328278	3-FR2
BD-344864	13-14	ED-330320	3-D14	EI-344764	7-IC1	ER-328278	3-FR3
BD-344865B	13-13	ED-330320	3-D17	EI-346122	3-IC4	ER-333429	3-R76
BH-T2051A030C	1-1	ED-337575	4-D1	EI-346965	5-IC1N	ER-333625	3-R75
BL-T2051A040A	1-8	ED-337575	4-D13	EI-346966	5-IC2N	ER-336804	6-FL2U
BM-B314815	2-2	ED-337575	6-D1	EI-347434	5-X1	ER-336830	6-FL6V
BT-347592	12-7U	ED-337575	6-D4	EI-347434	5-X2	ER-337327	6-FL5U
BT-347593	12-7C	ED-337575	6-D10	EI-347454	5-IC1	ER-337328	6-FL5C
BT-347594	12-7A	ED-337575	6-D5	EI-347455	5-IC2	ER-337695	4-FL1
BT-347595	12-7E	ED-337605	6-D8	EI-749983	11-ICZ01	ER-338338	6-FL2L
BT-347596	12-7S	ED-337605	6-D7	EJ-329610	7-1	ER-341654	6-FL3
BT-347690	12-5U	ED-343410	3-D1	EJ-336904	7-J1	ER-341920	3-FR1
BT-347691	12-5C	ED-343410	3-D2	EJ-343378	3-TM1	ER-343352	6-FL4U
BT-347692	12-5E	ED-344244	1-31	EJ-344423	6-TM1	ER-343353	6-FL4C
BT-347693	12-5S	ED-344280	6-D2	EJ-347474	3-J10	ER-343420	5-SR3
EC-302265	4-C63	ED-345149	3-D6	EJ-347618	3-J8	ER-345729	6-FL1L
EC-306022	4-C45	ED-345149	3-D8	EJ-347619	3-J9	ER-347164	5-SR5
EC-307494	4-C61	ED-345149	3-D9	EL-347456	5-LP2	ER-347164	5-SR6
EC-307725	4-C58	ED-345149	3-D21	EL-347456	5-LP1	ER-347437	5-SR1
EC-314688	8-C1C	ED-346286	4-D6	EL-347456	5-LP3	ER-347438	5-SR2
EC-314688	8-C2C	ED-346574	3-D7	EL-347456	5-LP4	ER-347688	5-SR4
EC-314990	4-C67	ED-346583	3-D15	EM-347469	5-IND1	ES-336780	5-SW8
EC-314992	4-C13	ED-346583	3-D20	EO-202215	6-T5	ES-336780	5-SW1
EC-320548	8-C1U	ED-347149	5-D27	EO-202216	6-T8	ES-336780	5-SW2
EC-320548	8-C2U	ED-347963	3-D19	EO-307786	6-T6	ES-336780	5-SW3
EC-326583	3-C37	ED-348200	3-D11	EO-315758	4-FL5	ES-336780	5-SW4
EC-330692	5-TC1	ED-348205	6-D3	EO-330719	5-L1	ES-336780	5-SW5
EC-330692	6-VC1	ED-348205	6-D9	EO-336738	4-FL3	ES-336780	5-SW6
EC-330692	6-VC2	ED-705414	11-LED01	EO-336878	6-T1	ES-336780	5-SW7
EC-330692	6-VC3	ED-705414	11-LED02	EO-336879	6-T2	ES-336780	11-S28
EC-337777	4-C59	EE-337976	12-12	EO-336934	3-L3	ES-336780	11-S27
EC-338577	8-C1E	EF-306950	3-F4U	EO-336934	5-L2	ES-336780	11-S11
EC-338577	8-C2E	EF-306950	3-F5U	EO-336934	7-L2	ES-336780	11-S05
EC-343855	3-C29	EF-306950	8-F2U	EO-336934	7-L3	ES-336780	11-S26
EC-344478	6-C25C	EF-306950	8-F3U	EO-337598	6-T3	ES-336780	11-S25
EC-344478	6-C26C	EF-306951	3-F8U	EO-337599	6-T4	ES-336780	11-S07
EC-344481	6-C42	EF-306951	3-F9U	EO-337774	4-T1	ES-336780	11-S23
EC-344482	6-C27	EF-306954	3-F4C	EO-337880	3-L1	ES-336780	11-S08
EC-344482	6-C28	EF-306954	3-F5C	EO-338409	8-FL1	ES-336780	11-S21
EC-344482	6-C43	EF-306956	3-F8C	EO-338420	3-L5	ES-336780	11-S03
EC-344483	6-C36	EF-306956	3-F9C	EO-338420	7-L1	ES-336780	11-S19
EC-344486	6-C26U	EF-306957	8-F2C	EO-342936	3-L4	ES-336780	11-S18
EC-344486	6-C25U	EF-309387	3-F6U	EO-343351	6-T7	ES-336780	11-S01
EC-345605	3-C33	EF-309387	8-F1U	EO-345904	6-L1	ES-336780	11-S22
EC-345605	3-C36	EF-309390	3-F7C	EO-347162	4-L2	ES-336780	11-S17
EC-346689	5-C23	EF-310229	3-F6C	EP-337067	4-RL1	ES-336780	11-S09
ED-200213	3-D10	EF-310229	8-F1C	EP-344251	2-18	ES-336780	11-S02
ED-200469	5-D2	EF-327103	3-F7U	EP-347611	8-RL1A	ES-336780	11-S20
ED-200469	5-D4	EF-593706	3-F7E	ER-200940	3-R36	ES-336780	11-S04
ED-200469	5-D23	EF-601301	3-F4E	ER-307565	4-FR1	ES-336780	11-S06
ED-200469	8-D1	EF-601301	3-F5E	ER-307565	4-FR2	ES-336780	11-S13
ED-200469	9-D4	EF-601301	3-F8E	ER-308028	3-R49	ES-336780	11-S10
ED-200469	9-D3	EF-601301	3-F9E	ER-311685	3-R40	ES-336780	11-S12
ED-224526	3-D18	EF-601301	8-F2E	ER-315407	6-FL1U	ES-336780	11-S14
ED-224526	5-D5	EF-623103	3-F6E	ER-321153	3-R43	ES-336780	11-S24
ED-301911	3-D3	EF-623103	8-F1E	ER-322787	3-R55	ES-336780	11-S15
ED-301911	3-D4	EH-749948	11-X01	ER-322787	3-R58	ES-337902	8-SW1A

INDEX

PARTS NO.	REF. NO.	PARTS NO.	REF. NO.	PARTS NO.	REF. NO.	PARTS NO.	REF. NO.
ES-344253	1-10	ET-398788	11-Q02	TC-344219	2-7		
ES-344257	1-11	ET-452531	3-TR6	TC-344221	2-9		
ES-344439	5-SW10	ET-452531	3-TR11	TC-344224	2-13		
ES-344439	6-SW2	EV-315413	4-VR5	TC-344225	2-14		
ES-344445	6-SW1	EV-315414	4-VR1	TC-344226	2-15		
ES-347436	5-SW9	EV-315416	4-VR3	TC-344901	2-3		
ES-347616	3-SW1	EV-322413	4-VR2	TP-344222	2-11		
ES-347617	8-SW2B	EV-336785	4-VR4	TP-344223	2-12		
ES-347966	5-SW12	EV-337993	6-VR1	TP-344879A	13-16		
ES-347966	5-SW11	EV-337995	6-VR2	TP-344879B	13-17		
ES-348463	8-SW1B	EV-347614	3-VR1	ZG-312923	1-28		
ES-749947	11-SL-SW	EV-347615	3-VR2	ZG-312925	1-33		
ET-200505	4-TR4	EW-305691	12-2A	ZG-312943	10-6		
ET-200505	4-TR22	EW-306428	12-2U	ZG-312995	1-12		
ET-200505	4-TR23	EW-336923	12-2E	ZG-322189	13-9x		
ET-200505	4-TR28	EW-336924	12-2S	ZG-336615	1-36		
ET-200505	4-TR29	EW-343363	12-2C	ZG-343104	1-2		
ET-200505	4-TR30	EW-347025	12-2B	ZG-343152	2-6		
ET-200505	6-TR24	EZ-631945	12-3	ZG-344188	1-15		
ET-200558	4-TR18	HE-337047	1-7	ZG-344194	1-21		
ET-200558	4-TR19	HP-344252	1-6	ZG-344200	1-25		
ET-200558	4-TR20	MB-344230	2-21	ZG-344227	2-16		
ET-200558	5-TR1	MB-344231	2-22	ZG-344240	1-37		
ET-200558	5-TR2	MB-344905	2-23	ZG-344900	1-3		
ET-200558	5-TR3	MI-B344207	2-4	ZG-347622	13-7x		
ET-200985	4-TR3	MI-B344215	2-5	ZG-348994	10-4		
ET-200985	4-TR34	MI-B344228	2-20	ZS-301398	12-8		
ET-201580	4-TR9	ML-344191	1-19	ZS-315511	12-6x		
ET-246846	6-TR18	ML-344192	1-20	ZS-322570	13-20		
ET-246846	6-TR22	ML-344196	1-24	ZS-341962	13-18x		
ET-246846	6-TR20	ML-344197	1-26	ZS-343153	2-10		
ET-246846	6-TR13	ML-344742	1-32	ZS-344914	12-11x		
ET-246846	6-TR14	ML-344743	1-27	ZS-417328	1-4		
ET-246846	6-TR16	ML-344857	12-9x	ZS-565211	1-5		
ET-301165	3-TR13	MP-336153	1-9	ZW-305013	12-13x		
ET-302502	11-Q01	MT-305793	1-17	ZW-305546	1-18		
ET-307195	3-TR1	MT-344187	1-14	ZW-340648	2-17		
ET-308141	4-TR2	MT-344190	1-16	ZW-343120	1-23		
ET-310148	3-TR12	MV-357208	1-29	ZW-345389	2-19		
ET-310148	3-TR14	MZ-B344179	1-38				
ET-310833	4-TR25	MZ-344297	1-34				
ET-310833	4-TR26	MZ-344850	10-1				
ET-311977	2-1	MZ-344853	10-5				
ET-318237	3-TR8	MZ-344906	1-22				
ET-318239	3-TR7	MZ-347146	10-2				
ET-318239	4-TR24	MZ-347620	10-3				
ET-322775	3-TR4	SA-347145	12-10				
ET-322775	3-TR5	SE-344239	1-35				
ET-322775	6-TR11	SE-344863	13-2				
ET-322775	6-TR9	SE-344873	10-7				
ET-322775	6-TR12	SE-344873B	10-7P				
ET-322778	3-TR2	SK-332534D	13-12				
ET-322778	6-TR4	SK-344220	2-8				
ET-322778	6-TR6	SK-344868A	13-4				
ET-322778	6-TR5	SK-344868C	13-5				
ET-322778	6-TR17	SK-344868E	13-6				
ET-328437	4-TR10	SK-344868F	13-4P				
ET-328578	4-TR5	SK-344868H	13-5P				
ET-328578	4-TR11	SK-344869	13-8				
ET-328578	4-TR12	SK-344870	13-11				
ET-328578	4-TR13	SK-344871	13-3				
ET-328578	4-TR14	SP-344862	13-10				
ET-328578	4-TR15	SP-344862B	13-10P				
ET-328578	4-TR16	SP-344872A	13-15				
ET-328578	4-TR17	SP-344872B	13-15L				
ET-328578	4-TR33	SP-344872E	13-15P				
ET-330464	6-TR21	SP-344872F	13-15LP				
ET-330588	6-TR10	SP-344875G	12-1U				
ET-330717	5-D28	SP-344875H	12-1C				
ET-332311	6-TR2	SP-344875J	12-1E				
ET-332421	4-TR8	SP-344875K	12-1S				
ET-336935	6-TR1	SP-344875L	12-1LE				
ET-336937	6-TR19	SP-344875M	12-1LB				
ET-337258	4-TR31	SP-749998	11-2				
ET-337604	6-TR7	SP-749999	11-2P				
ET-338081	5-TR4	SZ-332739	12-4				
ET-338081	5-TR5	TA-344883	11-3				
ET-338410	6-TR3	TA-344883B	11-4				
ET-344275	4-TR1	TA-347458	6-2				
ET-344275	4-TR32	TA-347459	6-2V				

SECTION 3

SCHEMATIC DIAGRAM

TABLE OF CONTENTS

1. SCHEMATIC DIAGRAM OF ICs	50
2. CONNECTION BLOCK DIAGRAM	65
3. CONTROL BLOCK DIAGRAM	66
4. POWER AND AMP BLOCK DIAGRAM	67
5. CONNECTION SCHEMATIC DIAGRAM	68
6. CONTROL SCHEMATIC DIAGRAM	69
7. FUNCTION SCHEMATIC DIAGRAM	70
8. FD-3 TUNER SCHEMATIC DIAGRAM	71
9. FD-3L TUNER SCHEMATIC DIAGRAM	72
10. PRE AMP SCHEMATIC DIAGRAM	73
11. MAIN AMP SCHEMATIC DIAGRAM	74
12. REMOCON AND FRONT END SCHEMATIC DIAGRAM	75

LA1231N

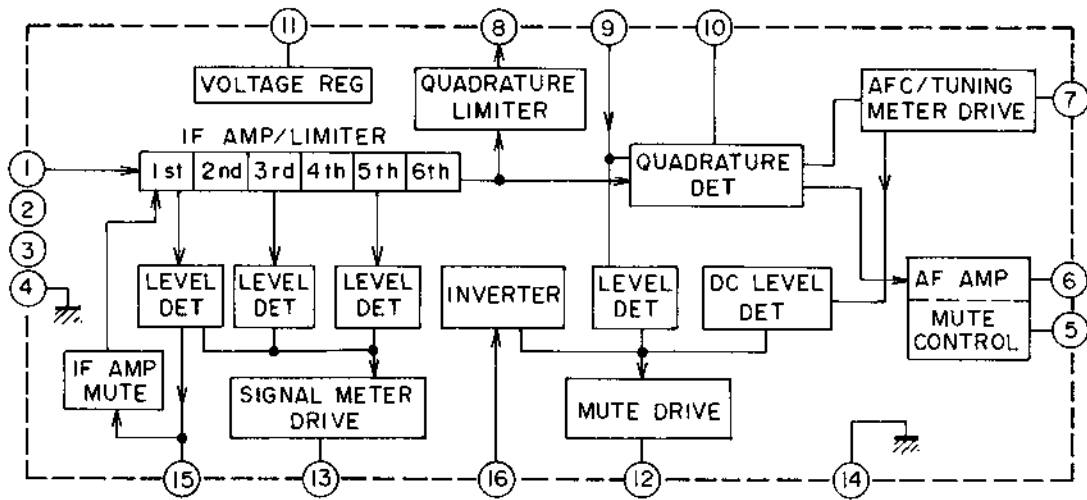

LA1245

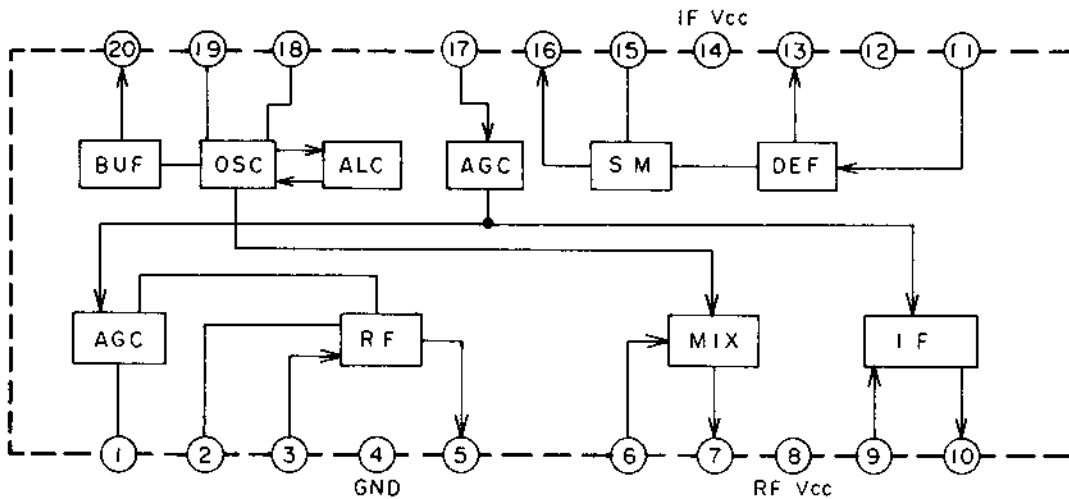

LC4069UB

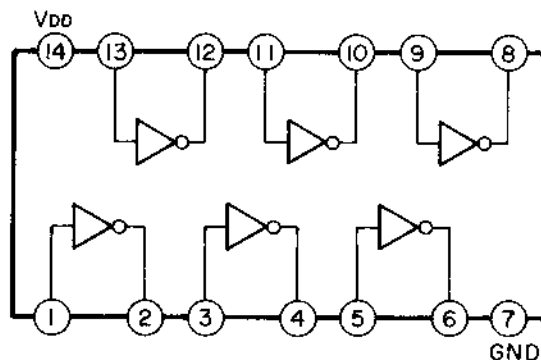

LA3390

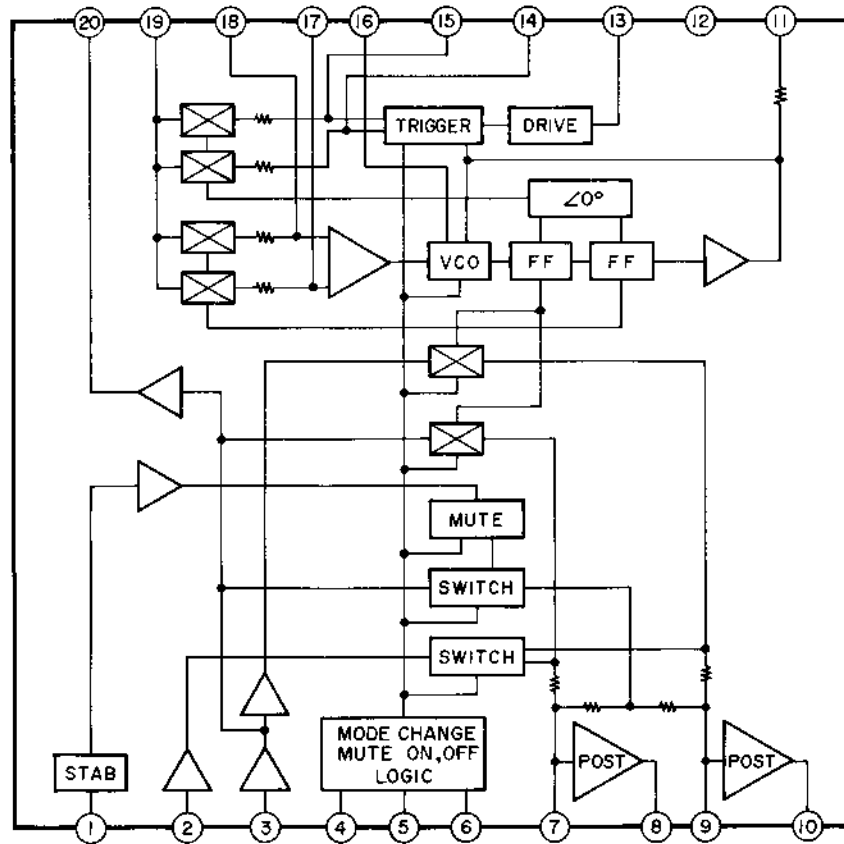

LB1240

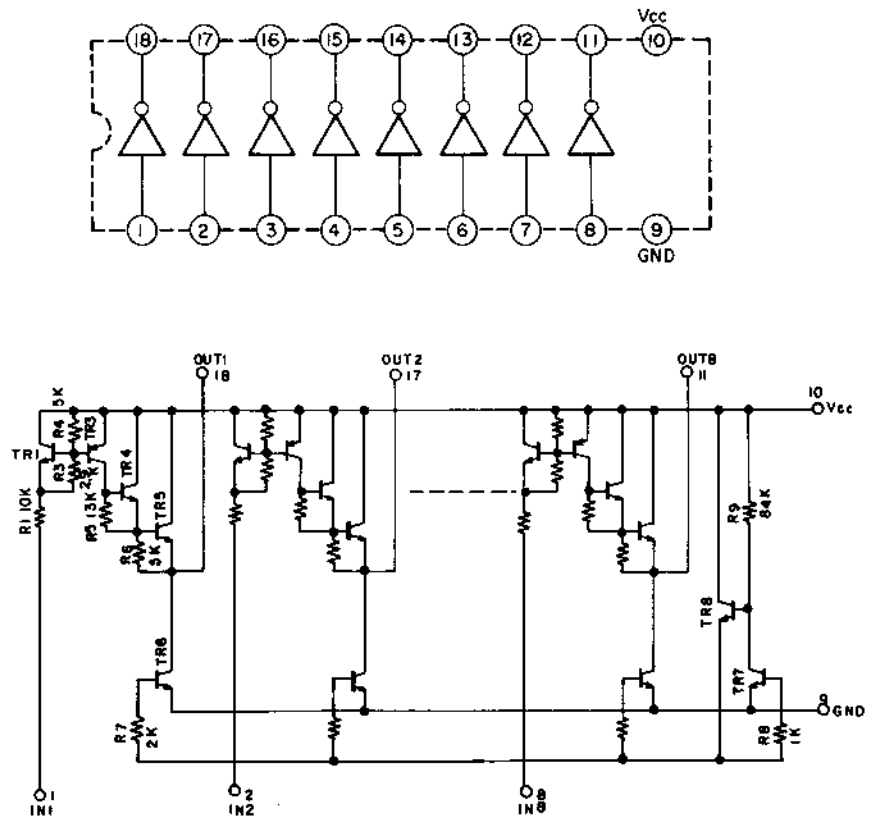

M5218P

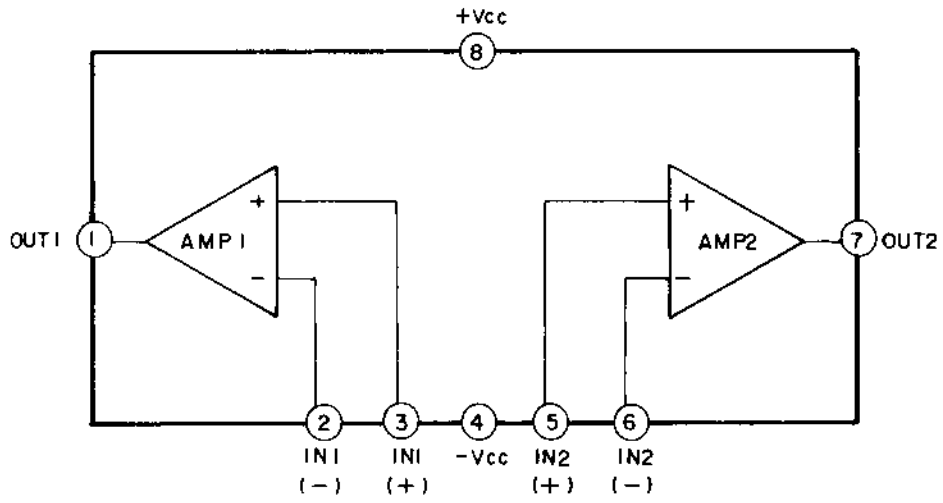

M54516

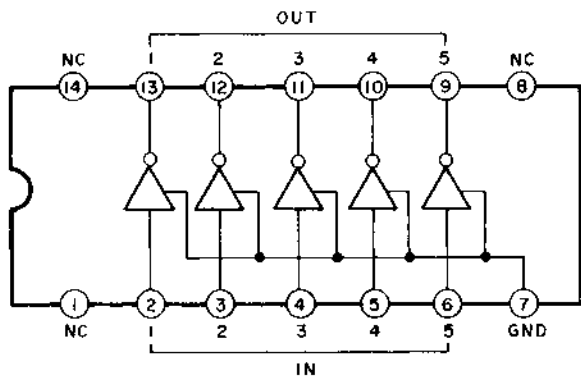

MC14069UB

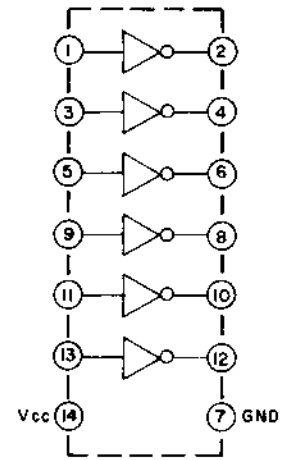

M54517P

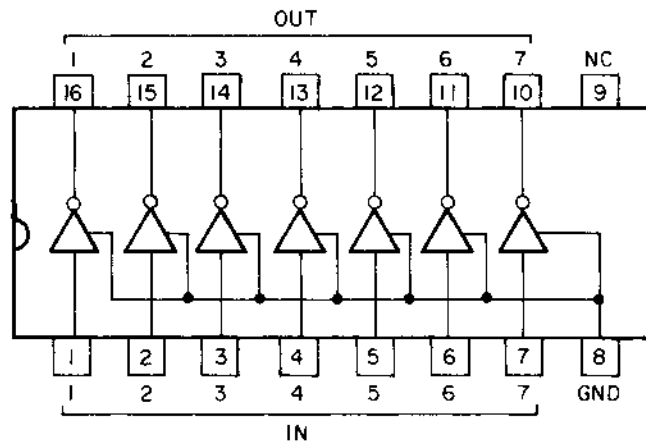

NE652

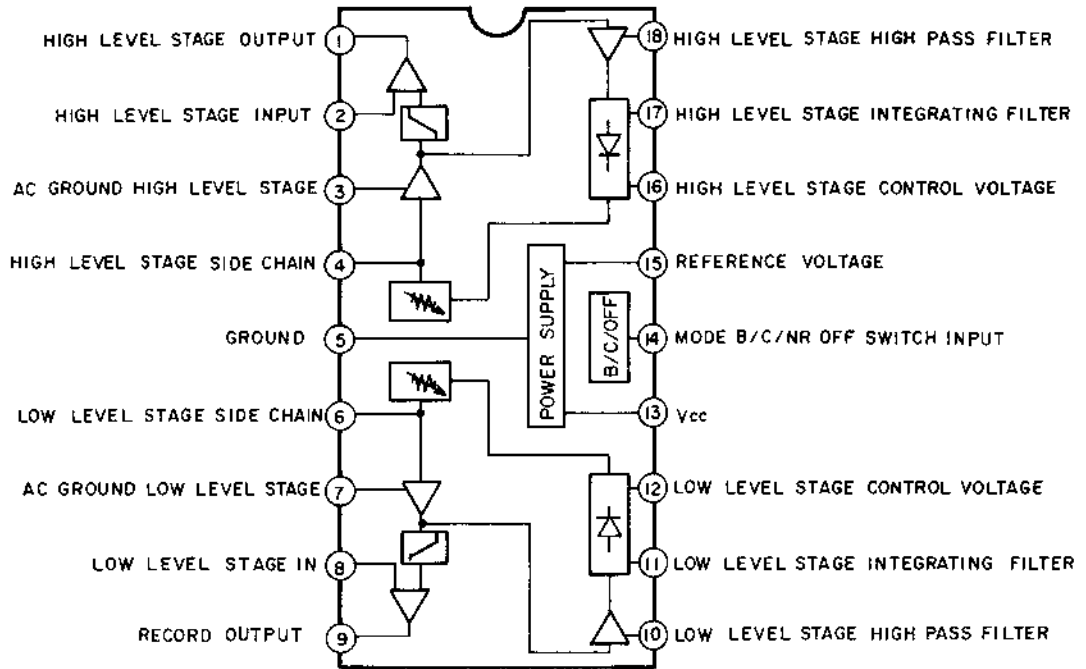

NE654

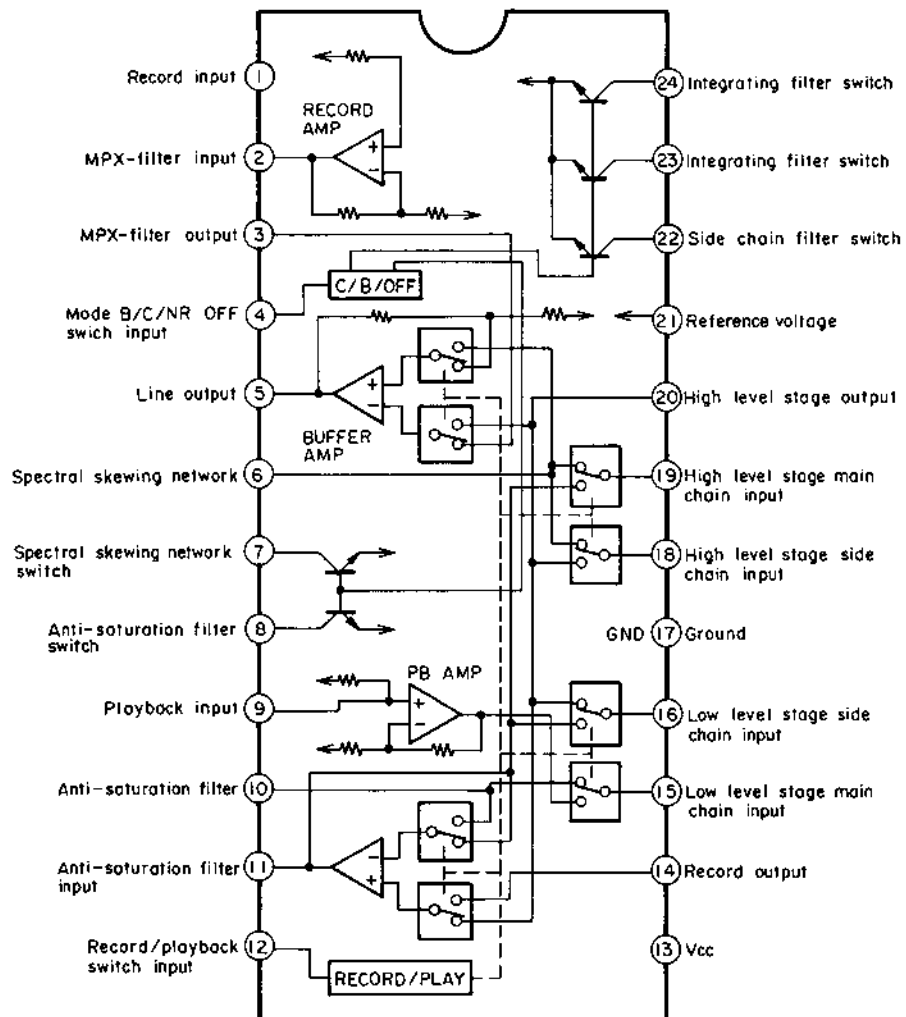

STK4833

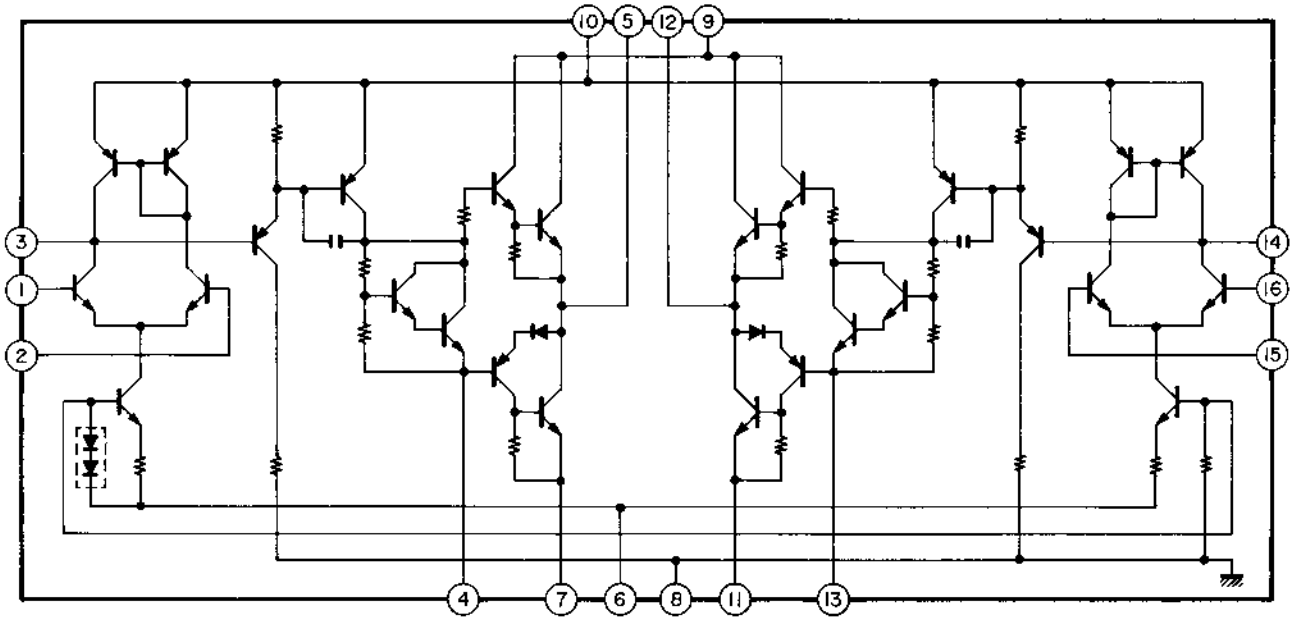

TA75458S

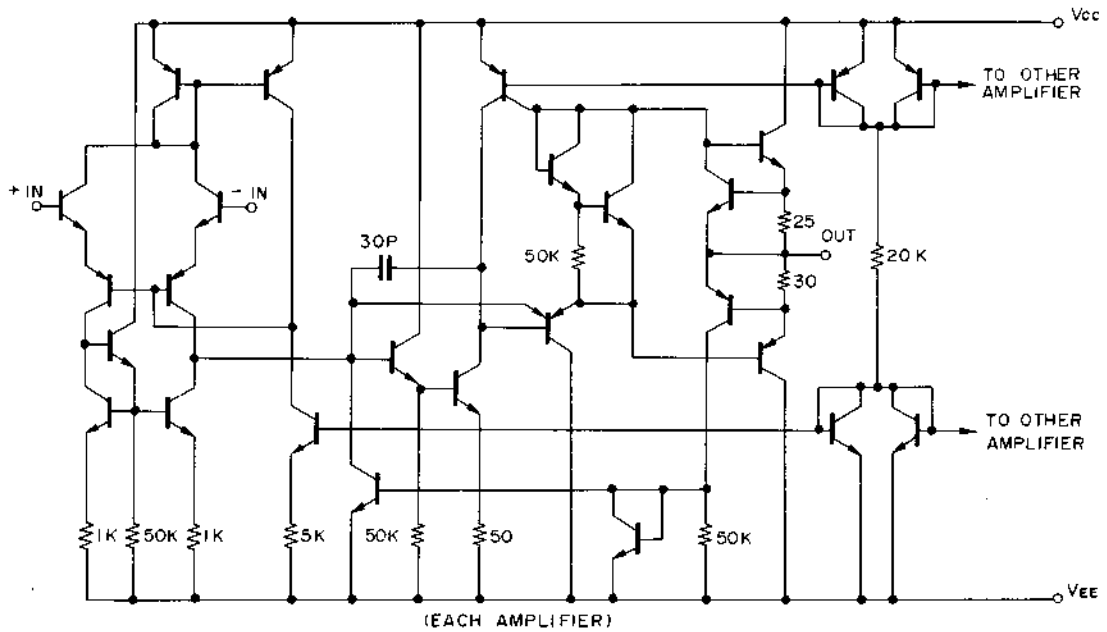
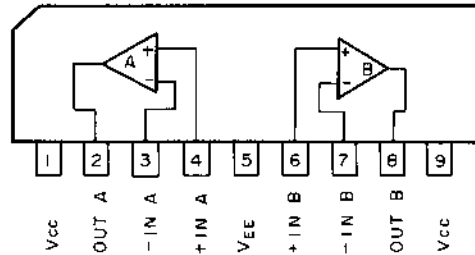

TC4052BP

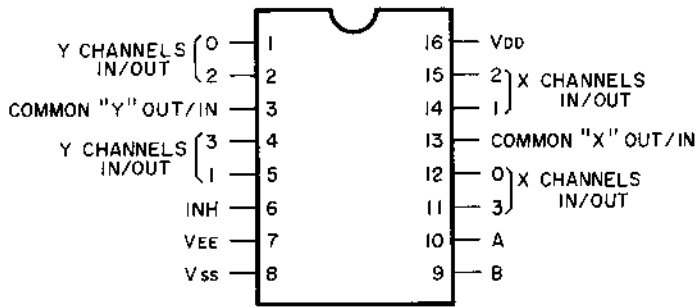

INHIBIT ⑥	A ⑩	B ⑨	"ON" CHANNEL
L	L	L	0X, 0Y
L	H	L	1X, 1Y
L	L	H	2X, 2Y
L	H	H	3X, 3Y
H	X	X	NONE

X=DON'T CARE

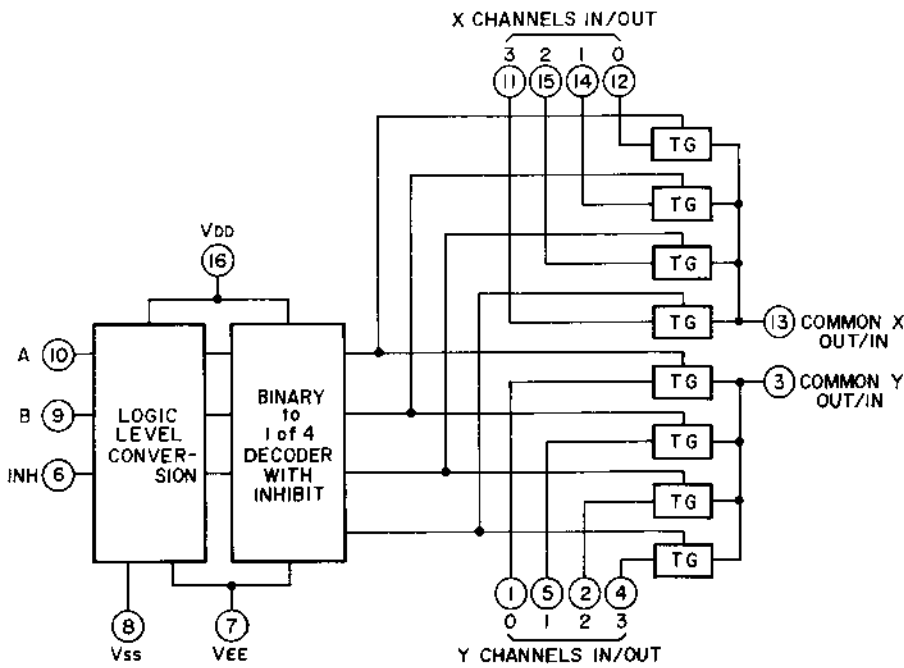

FUNCTION (Analogue SW IC TC4052BP) Selection Signal

Function	Output	
	A	B
PHONO	1	0
TUNER	0	1
AUX	1	1
TAPE	0	0

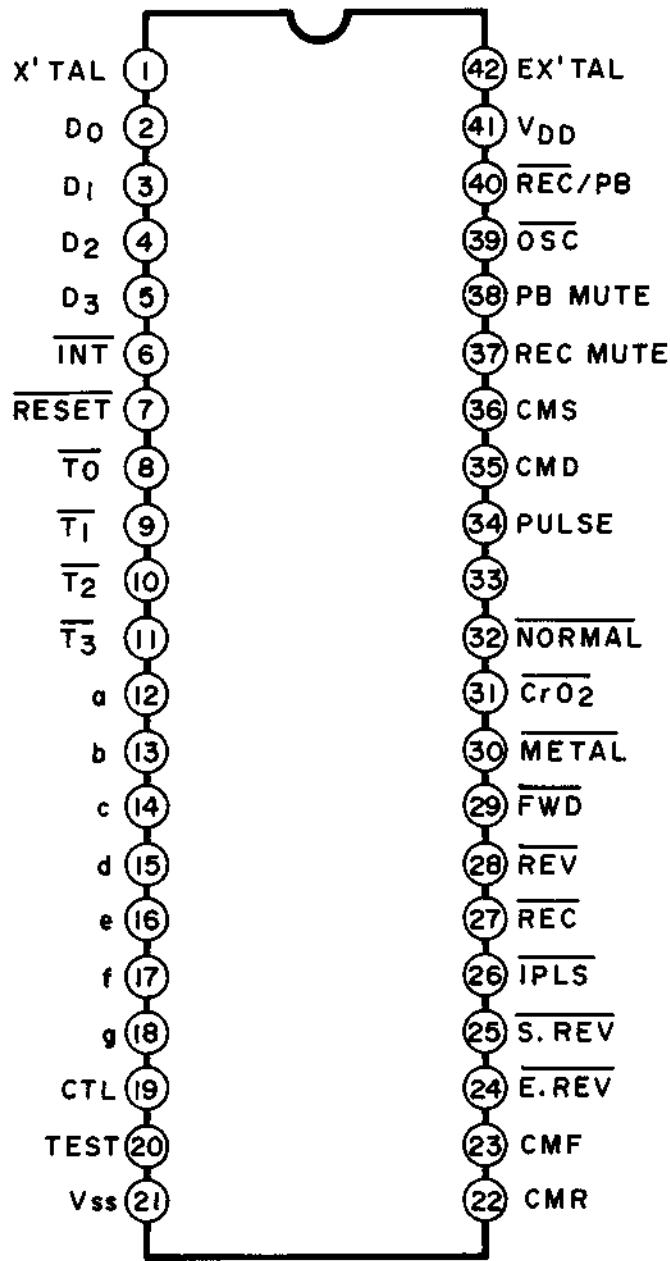

TERMINAL DESCRIPTION OF IC3 LM6405H-145

Pin No.	Symbol	Description
1	EXTAL	X'tal oscillator terminal
2	PULSE	Reel Rotation Pulse Detection input
3	D0	} Operation Control Data input
4	D1	
5	D2	
6	INT	Connected to ground
7	RESET	Reset Terminal
8	T0	8G
9	T1	9G
10	T2	10G
11	T3	11G
12	a	} FLD 7 Segment Data output
13	b	
14	c	
15	d	
16	e	
17	f	
18	g	
19		Not used (No connection)
20	TEST	} Connected to ground
21	Vss	
22	REC MUTE	REC Mute Control output, REC Mute at "H"
23	PB MUTE	PB Mute Control output, PB Mute at "H"
24	OSC	OSC Control output, Activate OSC at "L"
25	REC/PB	REC/PB Control output, REC mode at "L" & PB mode at "H"
26	PLUNGER (R)	PLUNGER (R) Drive
27	PLUNGER (F)	PLUNGER (F) Drive
28	REC LAMP	REC
29	PLAY LAMP	PLAY
30	METAL LAMP	METAL
31	CrO ₂ LAMP	CrO ₂
32	NORM LAMP	NORMAL
33	K0	} Digit Signal and Matrix input
34	K1	
35	REW	} Not used and connected to +5V line
36	STOP	
37	PLAY	
38	FF	
39	REC	
40	AUTO MUTE	
41	VDD	+5V
42	X TAL	X'tal oscillator terminal

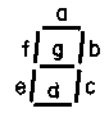

OPERATION CONTROL DATA

Function	IC Pin No. & Symbol	5	4	3
		D2	D1	D0
STOP		0	0	0
FF		0	0	1
REW		0	1	0
PLAY		0	1	1
REC		1	0	0
AUTO MUTE		1	0	1
REC PLAY		1	1	0
NO OPERATION		1	1	1

* 1 = "H", 0 = "L"

DIGIT SIGNAL & MATRIX

Symbol & Pin No.	T3 (11)	T2 (10)	T1 (9)	T0 (8)
K0 (33)			TS1	COUNTER RESET
K1 (34)			TS2	REC DETECTION

* TS1: TAPE SELECTOR SW901 (CrO₂)
 TS2: TAPE SELECTOR SW902 (METAL)
 REC DETECTION: A-R SW903 (ANTI REC)

TAPE SELECTION

IC Pin No. & SW	TS1	TS2	PIN 30	31	32
NORMAL	L	L	H	H	L
CrO ₂	L	H	L	H	H
METAL	H	H	H	L	H
	L	L	H	L	H

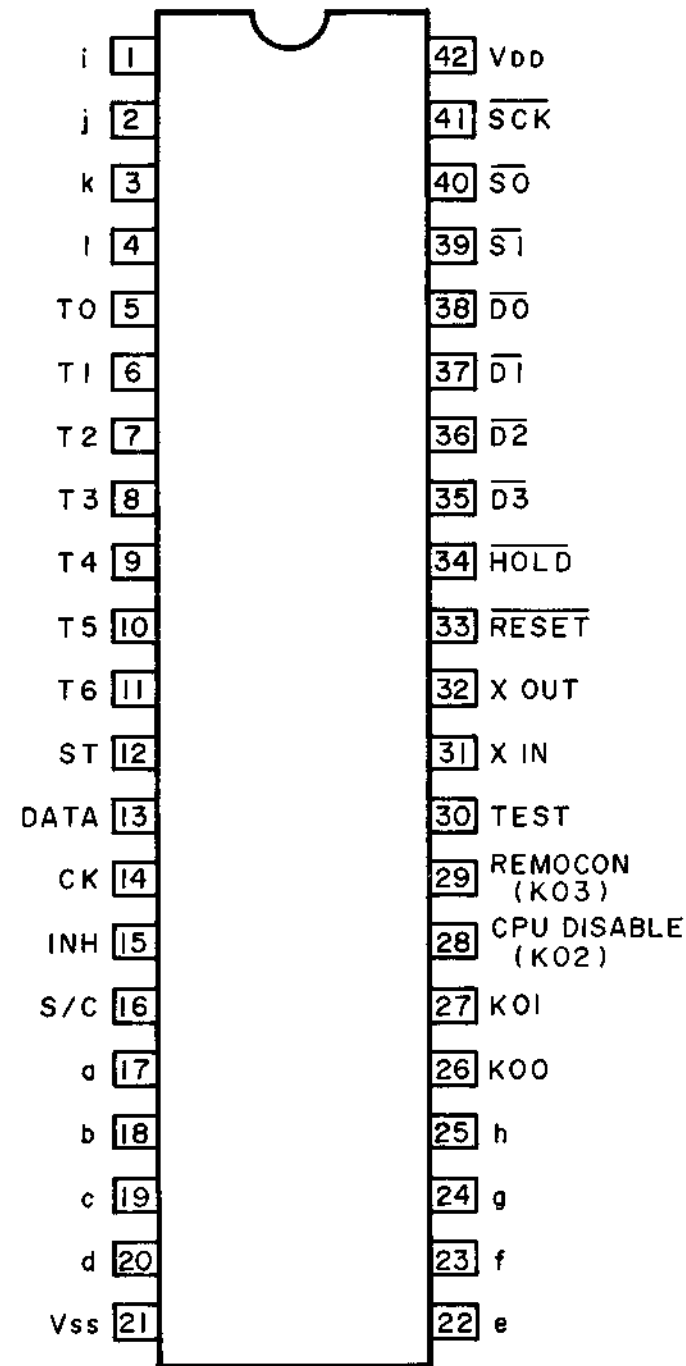

TERMINAL DESCRIPTION OF IC1 TC47C21P (NH-100)

Pin No.	Symbol	Description	
1	i	} FLD Segment Data output	
2	j		
3	k		
4	l		
5	T0	1G	} FLD Digit Designation output & Matrix Digit output
6	T1	2G	
7	T2	3G	
8	T3	4G	
9	T4	5G	
10	T5	6G	
11	T6	7G	
12	ST	Strobe Pulse	} for Electronic Volume (IC2: TC9154P) Control
13	DATA	Data Pulse	
14	CK	Clock Pulse	
15	INH	Key Input Inhibit signal input	
16	S/C	START/CUT, produces a pulse when PHONO button is depressed.	
17	a	} FLD 7 Segment Data output	
18	b		
19	c		
20	d		
21	Vss	Connected to ground	
22	e	} FLD 7 Segment Data output	
23	f		
24	g		
25	h	FLD Segment Data	
26	K00	} Key Matrix input	
27	K01		
28	CPU DISABLE (K02)	Key Input Inhibit signal output for IC2 TC47C20P (NH-20D)	
29	REMOCON (K03)	Remote Control Data Pulse input	
30	TEST	Connected to ground	
31	XIN	} X'tal oscillator (X1: 4.2 MHz) terminals	
32	XOUT		
33	RESET	Reset terminal	
34	HOLD	Back up Detection input	
35	D3	Not used and connected to +5V line	} Control Data output for IC3 LM6405H-145
36	D2		
37	D1		
38	D0		
39	S1	Input	} Serial Data between IC2 TC47C20P (NH-200)
40	S0	Output	
41	SCK	Clock	
42	VDD	+5V	

KEY INPUT MATRIX (FLD DIGIT Designation & Matrix Digit output)

Symbol (Pin No.) \ Symbol (Pin No.)	T6 (11)	T5 (10)	T4 (9)	T3 (8)	T2 (7)	T1 (6)	T0 (5)
K0 (26)	REC/PB	DISK END	FWD/REV	24h/12h	MIN	HOUR	TIMER ON/OFF
K1 (27)	SLEEP	TUNER REC	TAPE PLAY	TUNER PLAY	ON TIMER- SET	OFF TIMER- SET	CLOCK SET

CONTROL DATA for IC3 LM6405H-145

Function \ IC Pin & Symbol	35 D3	36 D2	37 D1	38 D0
STOP	0	0	0	0
FF	0	0	0	1
RWD	0	0	1	0
FWD	0	0	1	1
REC	0	1	0	0
REC MUTE	0	1	0	1
REC FWD	0	1	1	0
REV	1	0	1	1
REC REV	1	1	1	0

(ex) FWD

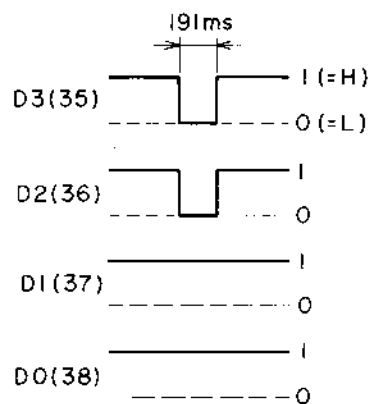

TC5066BP

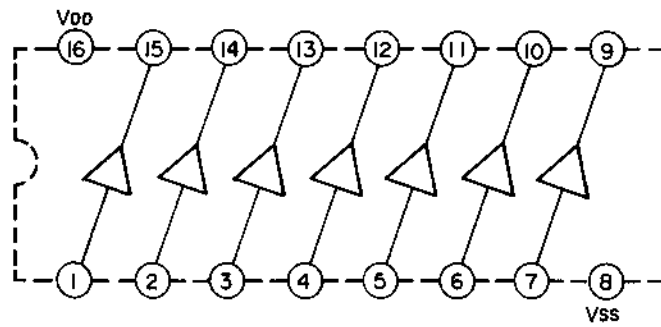

TC47C20P (NH-200)

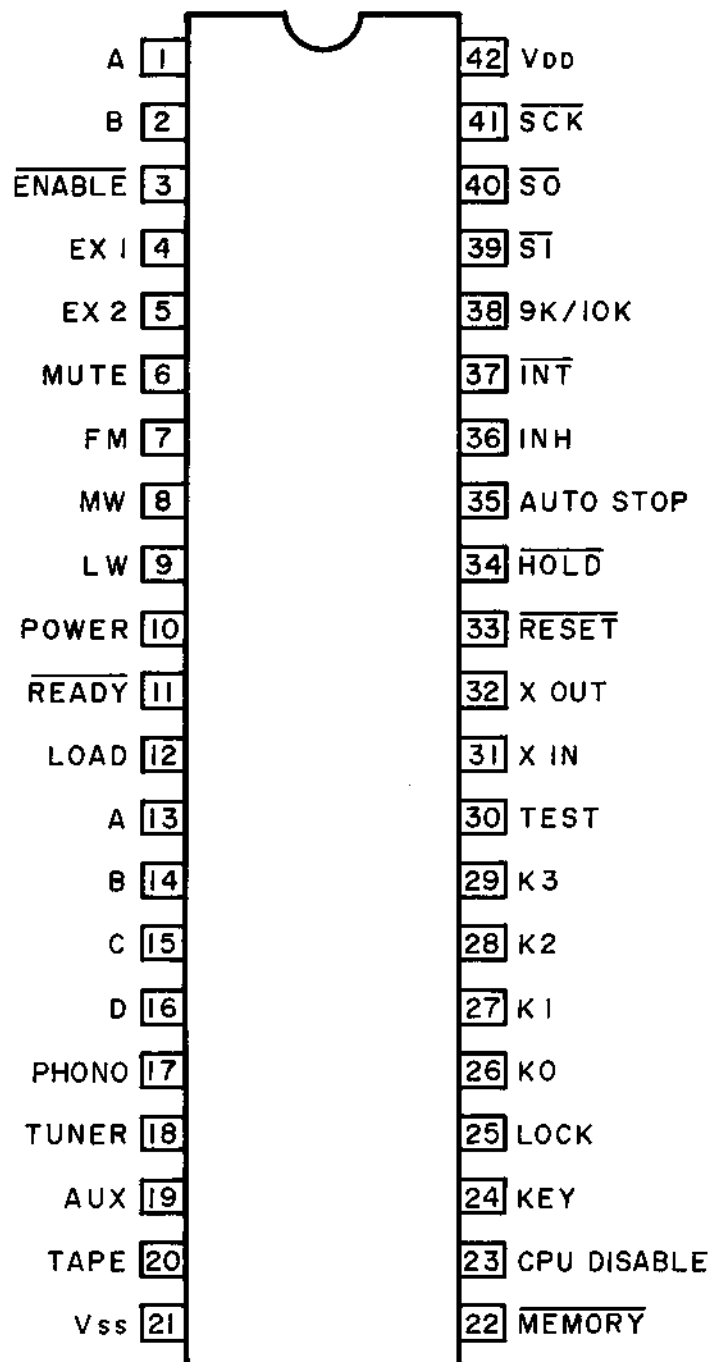

TERMINAL DESCRIPTION OF IC2 TC47C20P (NH-200)

Pin No.	Symbol	Description
1	A	} Function (Analogue SW) Selection signal output for IC2 (TC4052BP)
2	B	
3	$\overline{\text{ENABE}}$	Not used and connected to +5V line
4	EX1	} Not used and connected to +5V line
5	EX2	
6	MUTE	Tuner Section Audio Mute output
7	FM	} Band Selection Data output, active at "H"
8	MW	
9	LW	
10	POWER	Power Relay (RL1) Drive output
11	$\overline{\text{READY}}$	Not used and connected to +5V line
12	LOAD	PLL Data Write signal (PLL Load signal)
13	A	} PLL Frequency Data output for PLL IC (IC5: TC9125BP)
14	B	
15	C	
16	D	
17	PHONO	} Function Display, lit at "H"
18	TUNER	
19	AUX	
20	TAPE	
21	Vss	Connected to ground
22	$\overline{\text{MEMORY}}$	MEMORY (FLD) Display, lit at "L"
23	CPU DISABLE	Key Input inhibit signal output for IC1 TC47C21P (NH-101)
24	KEY	Key Input Common signal output
25	LOCK	Key Input Lock [K0 (2/3 Band), K2 (FM Band Upper/Lower), K3 (FM Step 50kHz/100kHz)]
26	K0	DOWN
27	K1	UP
28	K2	BAND
29	K3	MEMORY
		} Key Input
30	TEST	Connected to ground
31	XIN	} X'tal oscillator terminals
32	XOUT	
33	$\overline{\text{RESET}}$	Reset terminal
34	$\overline{\text{HOLD}}$	Back-up Detection
35	AUTO STOP	AUTO STOP Detection input, AUTO STOP at "H"
36	INH	Key Input inhibit signal input
37	$\overline{\text{INT}}$	Connected to 5V line
38	9K/10K	AM 9 kHz/10 kHz STEP Selection input, 9 kHz at "L" & 10 kHz at "H"
39	$\overline{\text{SI}}$	Input
40	$\overline{\text{SO}}$	Output
41	$\overline{\text{SCK}}$	Clock
		} Serial Data between IC1 TC47C21P (NH-100)
42	VDD	+5V

TC9125BP

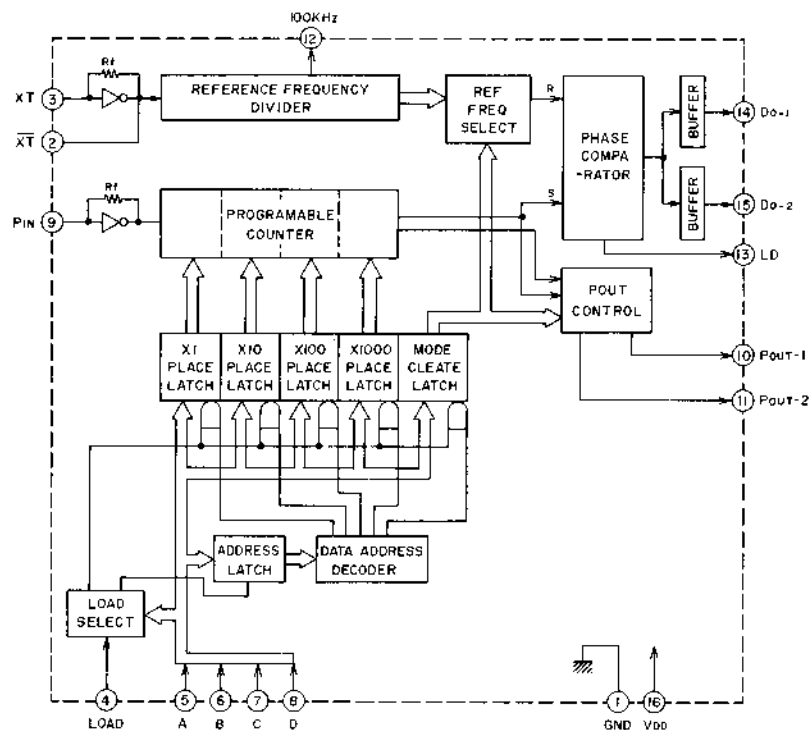

TERMINAL DESCRIPTION OF IC5 TC9125BP

Pin No.	Symbol	Designation of terminal	Description of functions and operations
1	GND	Earth terminal	
2	XT	Crystal oscillator connection terminal	Connection of 9.0 MHz crystal oscillator.
3	XT		
4	LOAD	Load input terminal	Data reading instruction input terminal for A, B, C and D. Data is read when this terminal is at "H" level, but when at "L" level, the previous data is held regardless of other inputs.
5	A	Program/data input terminals	Input terminal for reference frequency selection data and programmable counter division digit data.
6	B		
7	C		
8	D		
9	PIN	Programmable counter input terminal	
10	POUT-1	Programmable counter output terminal	To be connected to the prescaler TD6102P for fine adjustment of IF frequency in FM or for 50 kHz shift in Europe. The signal of Pout-1 and Pout-2 is output at the point of different phase. * Pout-2 is not used (No connection)
11	POUT-2		
12	100 kHz	100 kHz clock output terminal	Not used (No connection)
13	LD	Lock-out detection terminal	Not used (No connection)
14	Do-1	Phase comparator output terminal	To be connected to low-pass filter.
15	Do-2		
16	VDD	Power terminal	+5V

TC9154P

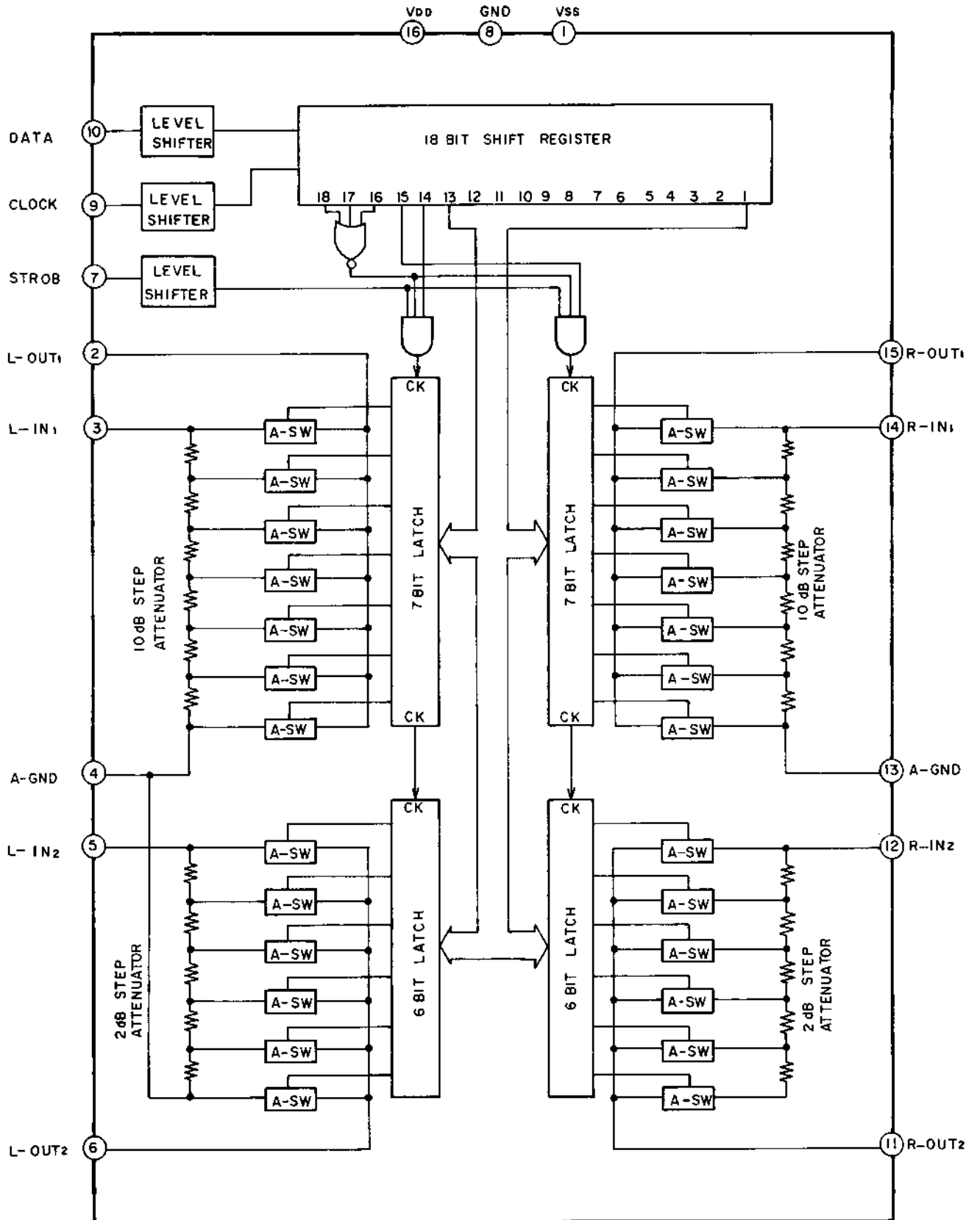

SCHEMATIC DIAGRAM FD-3

TD6102P

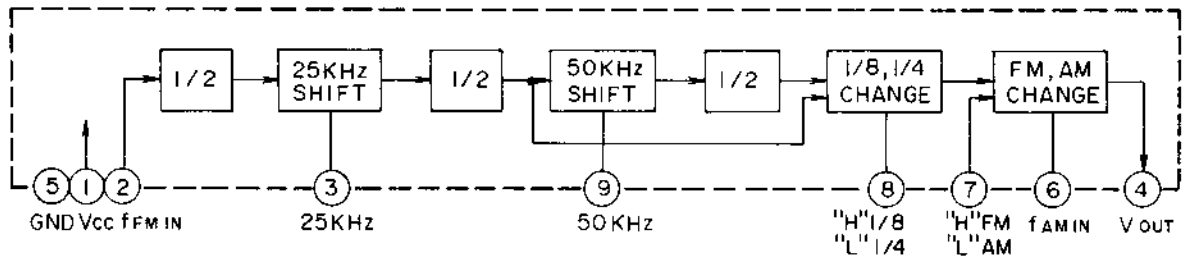

μPC 1373H

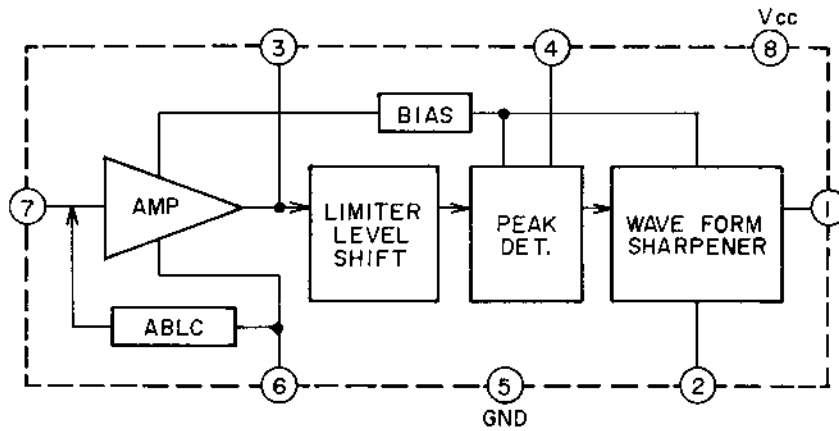

μPD 1943G

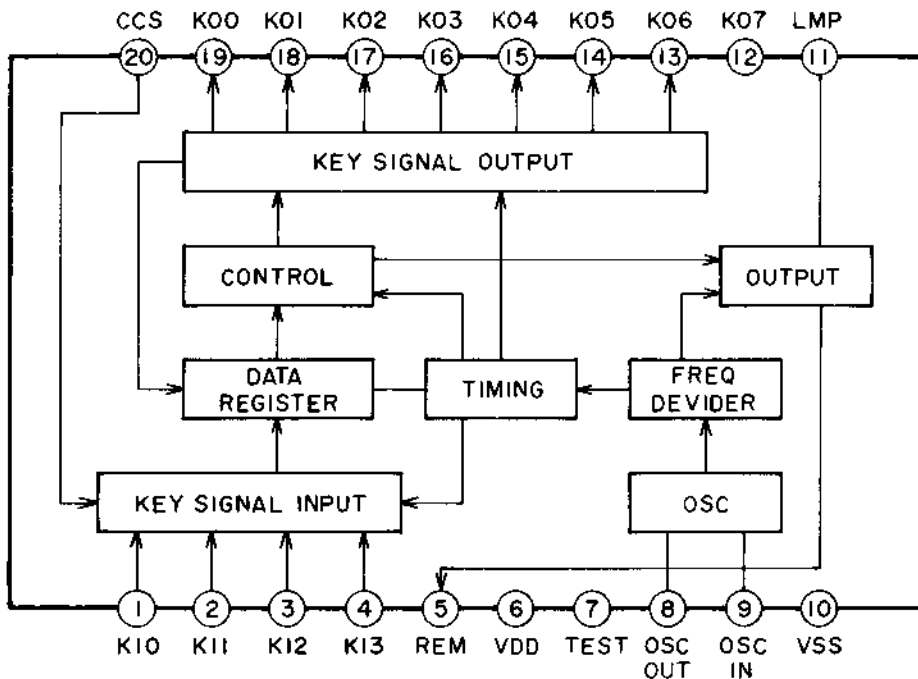

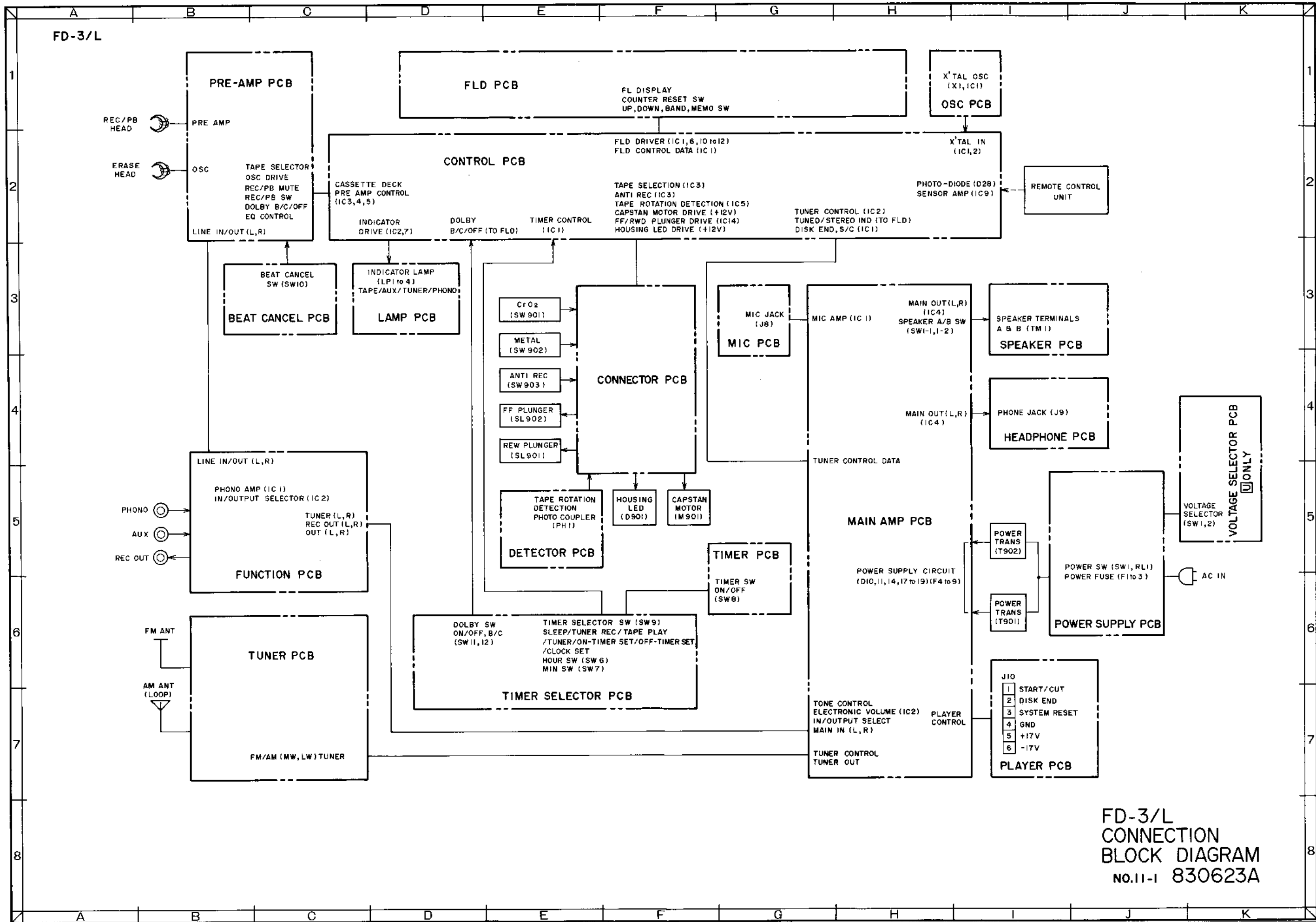

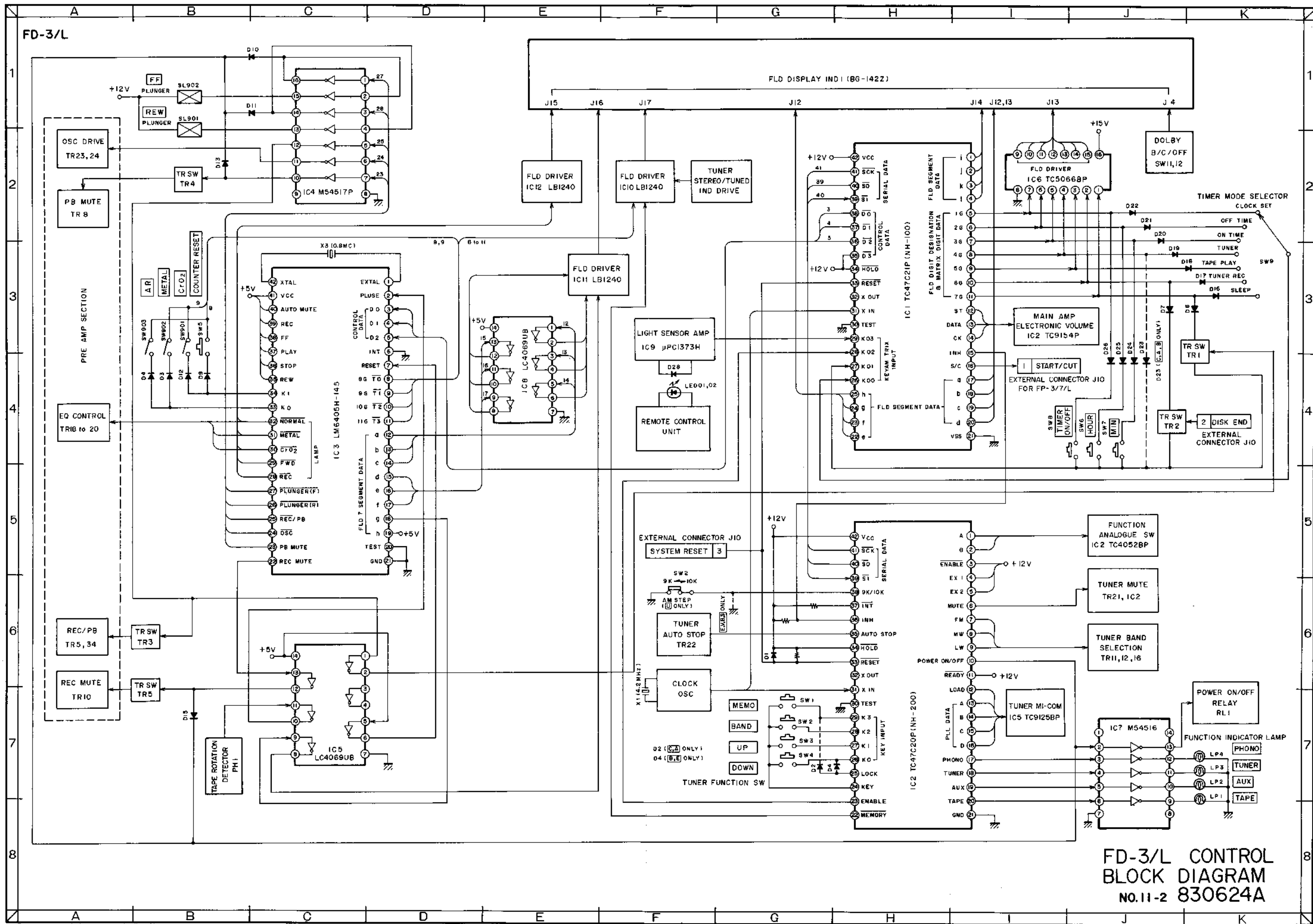

FD-3/L CONTROL BLOCK DIAGRAM
NO.11-2 830624A

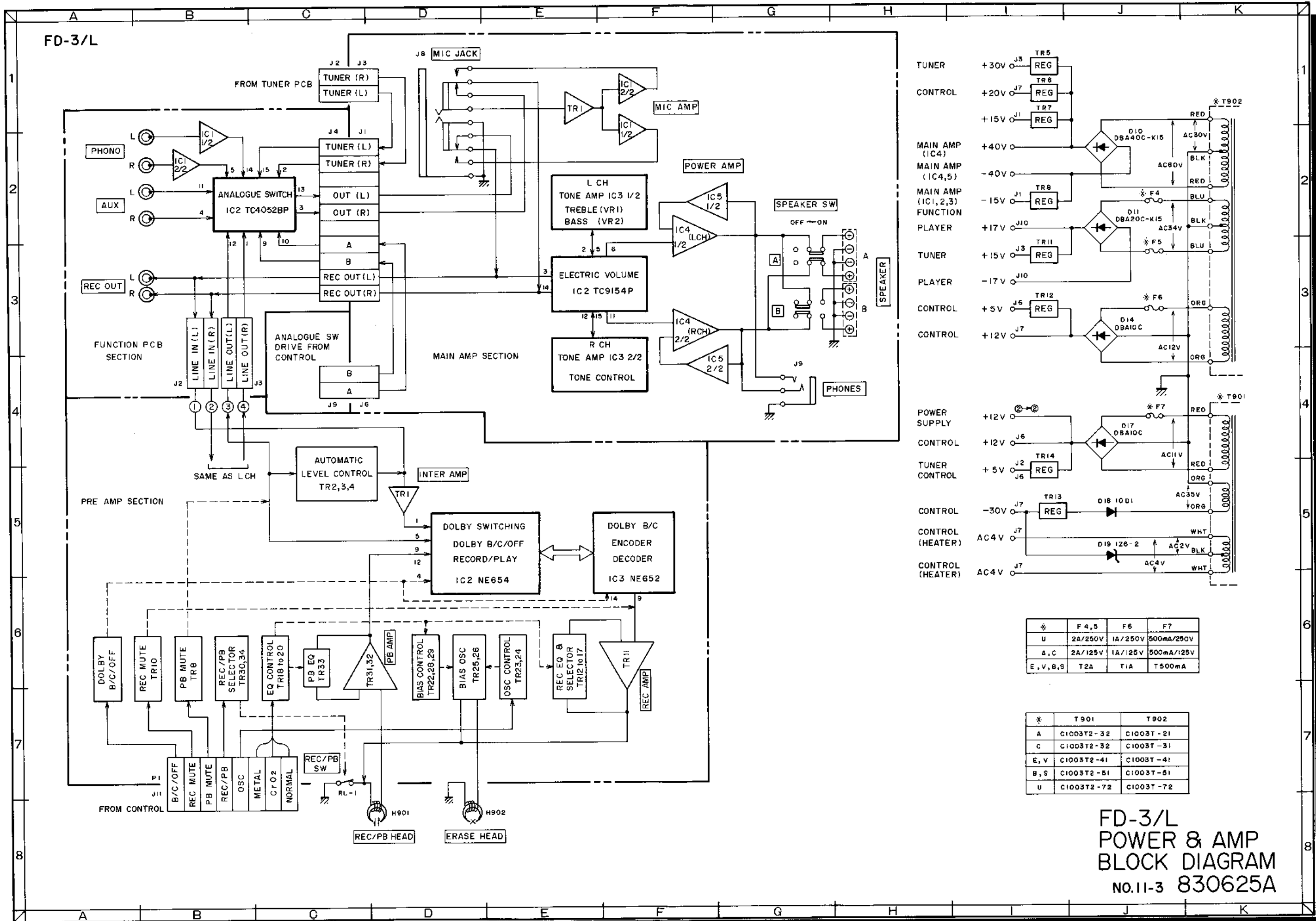

**FD-3/L
POWER & AMP
BLOCK DIAGRAM
NO.11-3 830625A**

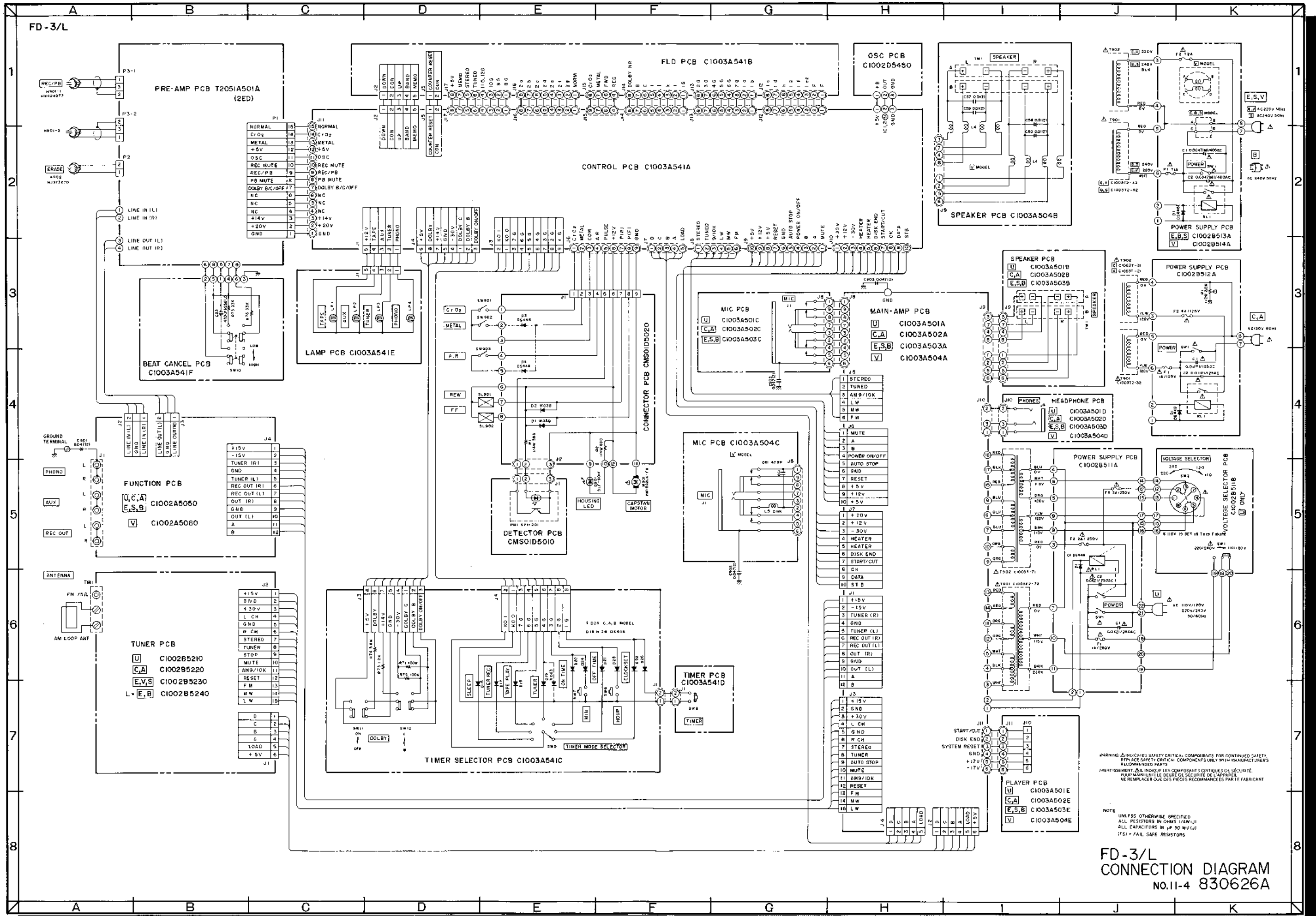

FD-3/L
 CONNECTION DIAGRAM
 No.11-4 830626A

FD-3/L

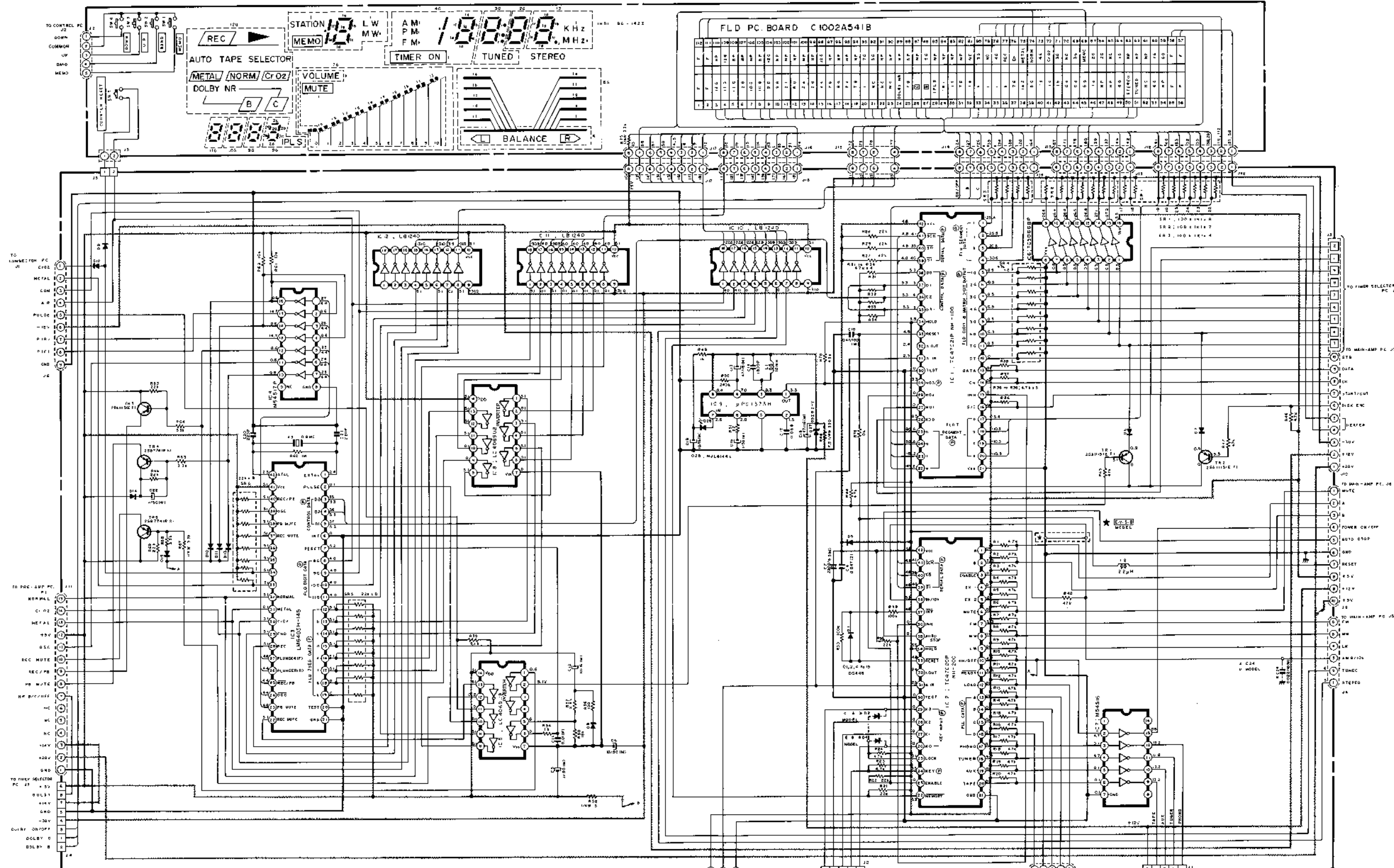

Voltages are measured at STOP mode
and under following conditions

- TAPE ---- METAL (W/OUT CASS TAPE)
- DOLBY ---- OFF
- COUNTER - 0000
- VOLUME -- STEP 4
- BALANCE - FLAT
- TIME ---- 0:00
- BAND ---- FM

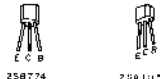

OSC PC B
C1002D5450

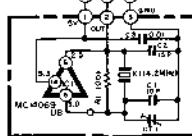

NOTES
UNLESS OTHERWISE SPECIFIED,
ALL RESISTORS IN OHMS (1-100K);
ALL CAPACITORS IN μF (50-100K)

FD-3/L CONTROL
SCHEMATIC DIAGRAM
No.11-5 830627A

①-⑩=POWER SUPPLY LINE

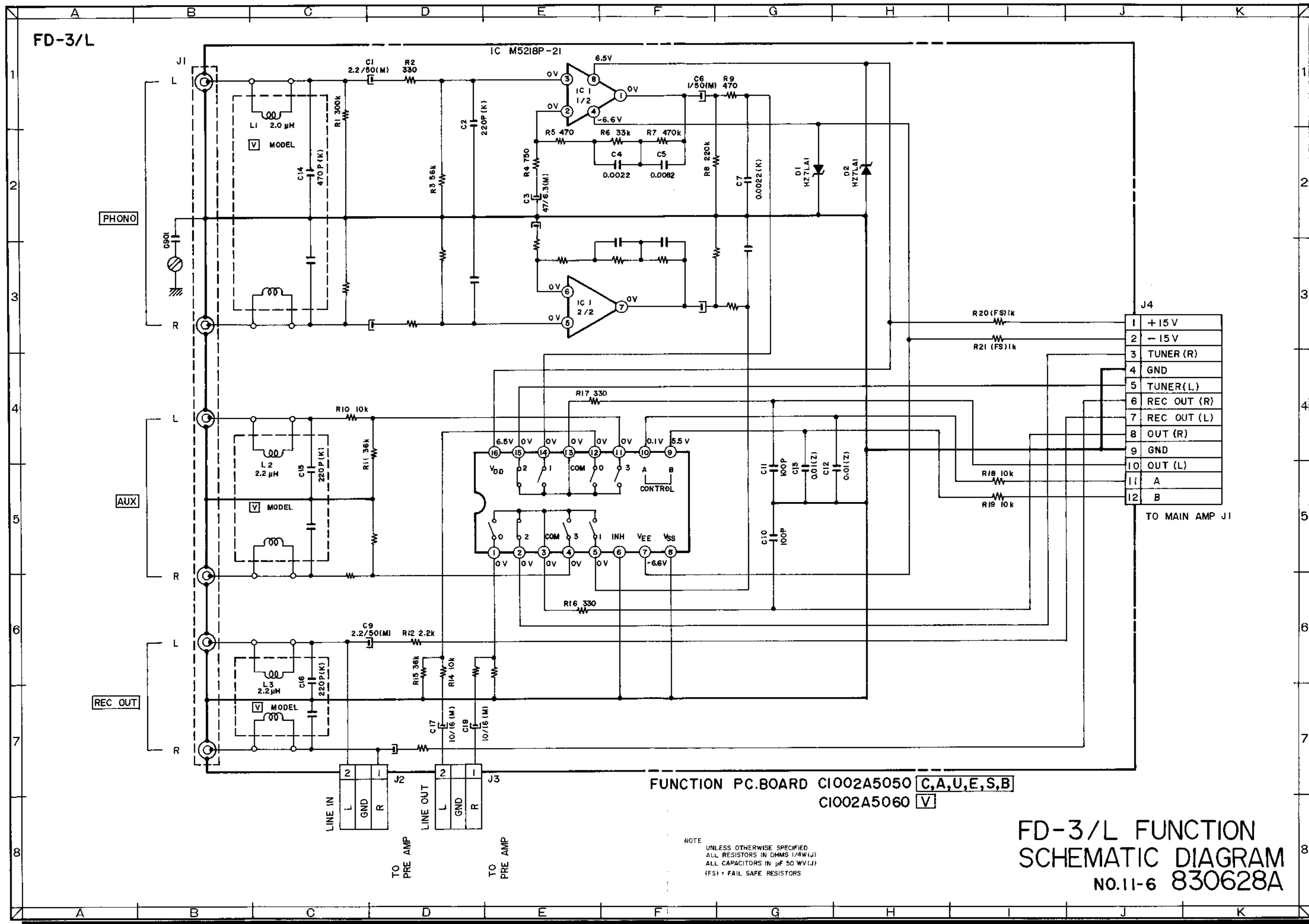

1	+15V
2	-15V
3	TUNER (R)
4	GND
5	TUNER (L)
6	REC OUT (R)
7	REC OUT (L)
8	OUT (R)
9	GND
10	OUT (L)
11	A
12	B

TO MAIN AMP J1

FUNCTION PC BOARD C1002A5050 [C,A,U,E,S,B]
C1002A5060 [V]

NOTE
UNLESS OTHERWISE SPECIFIED
ALL RESISTORS IN OHMS 1/4W(J)
ALL CAPACITORS IN µF 50 WV(J)
(FS) = FAIL SAFE RESISTORS

FD-3/L FUNCTION
SCHEMATIC DIAGRAM
NO.11-6 830628A

FD-3

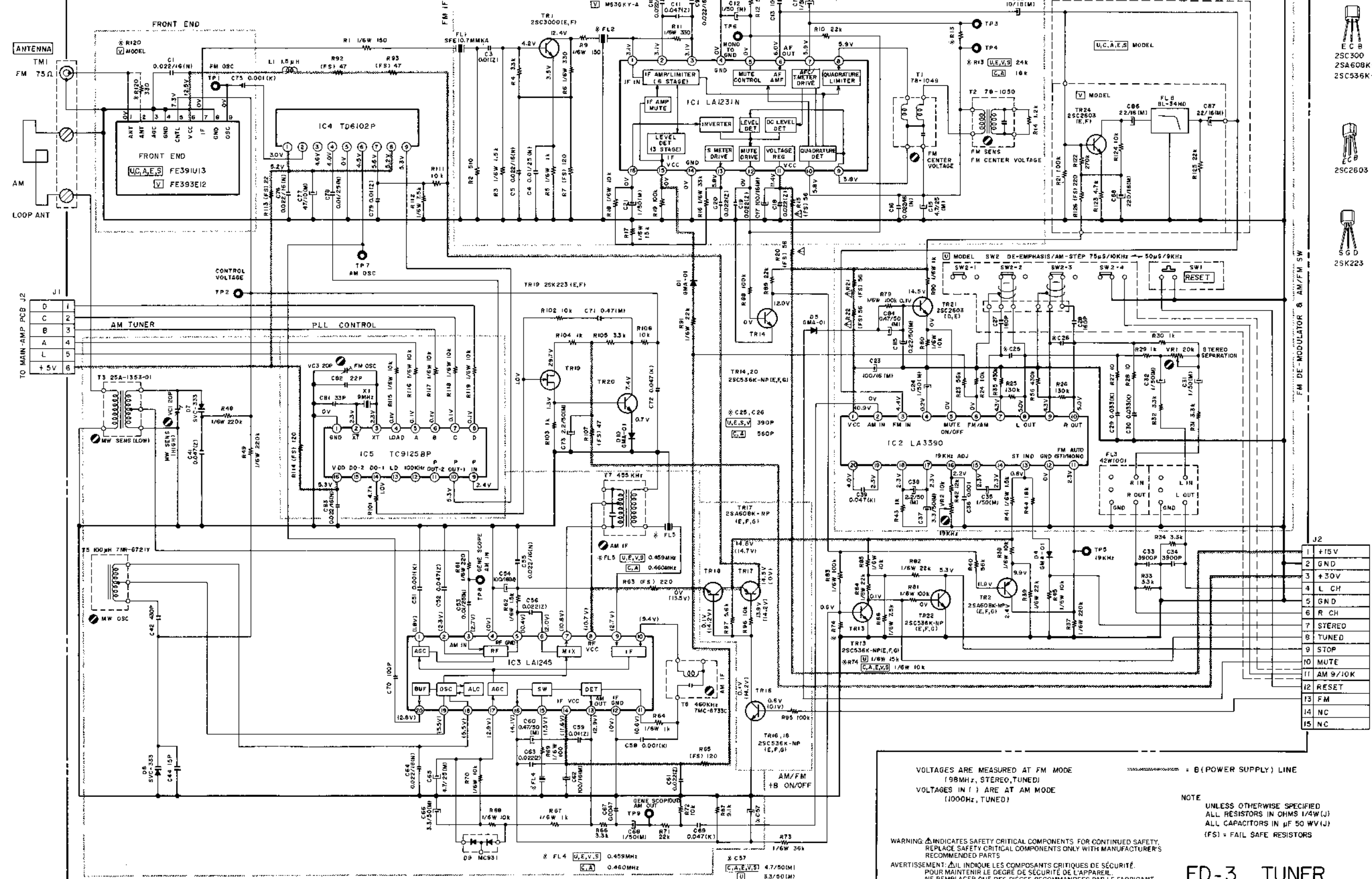

TO MAIN-AMP PCB J2

D	I
C	K
B	A
A	L
L	D
+5V	B

- ECB 25C300 25A608K-NP 25C536K-NP
- 25C2603
- SGD 25K223

FM DE-MODULATOR & AM/FM SW

MAIN-AMP PCB J3

1	+15V
2	GND
3	+30V
4	L CH
5	GND
6	R CH
7	STEREO
8	TUNED
9	STOP
10	MUTE
11	AM 9/10K
12	RESET
13	FM
14	NC
15	NC

VOLTAGES ARE MEASURED AT FM MODE (98MHz, STEREO, TUNED)
 VOLTAGES IN () ARE AT AM MODE (1000Hz, TUNED)

NOTE: UNLESS OTHERWISE SPECIFIED ALL RESISTORS IN OHMS 1/4W (J) ALL CAPACITORS IN μF 50 WV (J) (FS) = FAIL SAFE RESISTORS

WARNING: ⚠ INDICATES SAFETY CRITICAL COMPONENTS. FOR CONTINUED SAFETY, REPLACE SAFETY CRITICAL COMPONENTS ONLY WITH MANUFACTURER'S RECOMMENDED PARTS.

AVERTISSEMENT: ⚠ IL INDIQUE LES COMPOSANTS CRITIQUES DE SÉCURITÉ. POUR MAINTENIR LE DEGRÉ DE SÉCURITÉ DE L'APPAREIL, NE REMPLACER QUE DES PIÈCES RECOMMANDÉES PAR LE FABRICANT.

TUNER PCB U C1002B5210, CA C1002B5220, EVS C1002B5230

FD-3 TUNER
SCHEMATIC DIAGRAM
 No.11-7 630629A

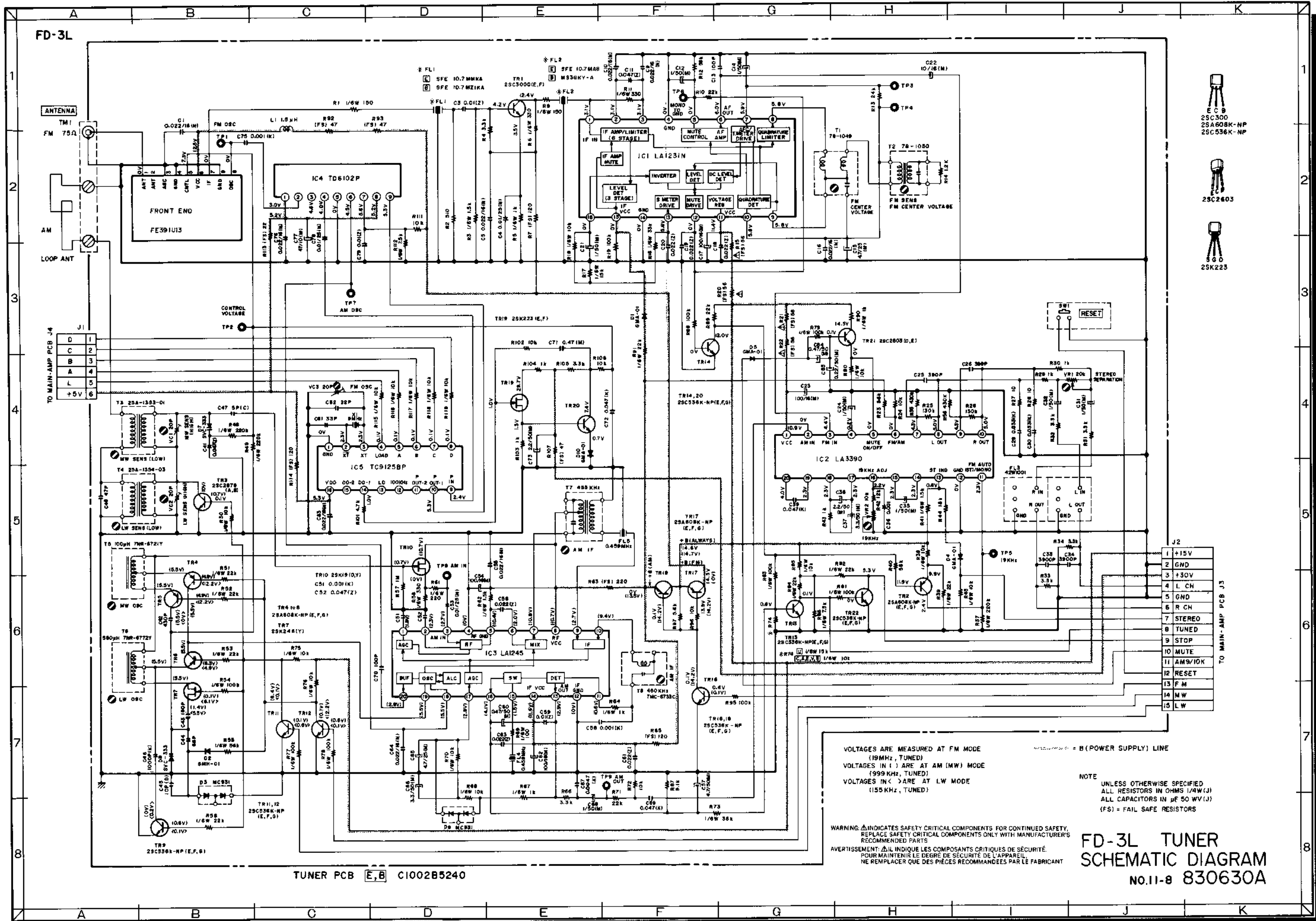

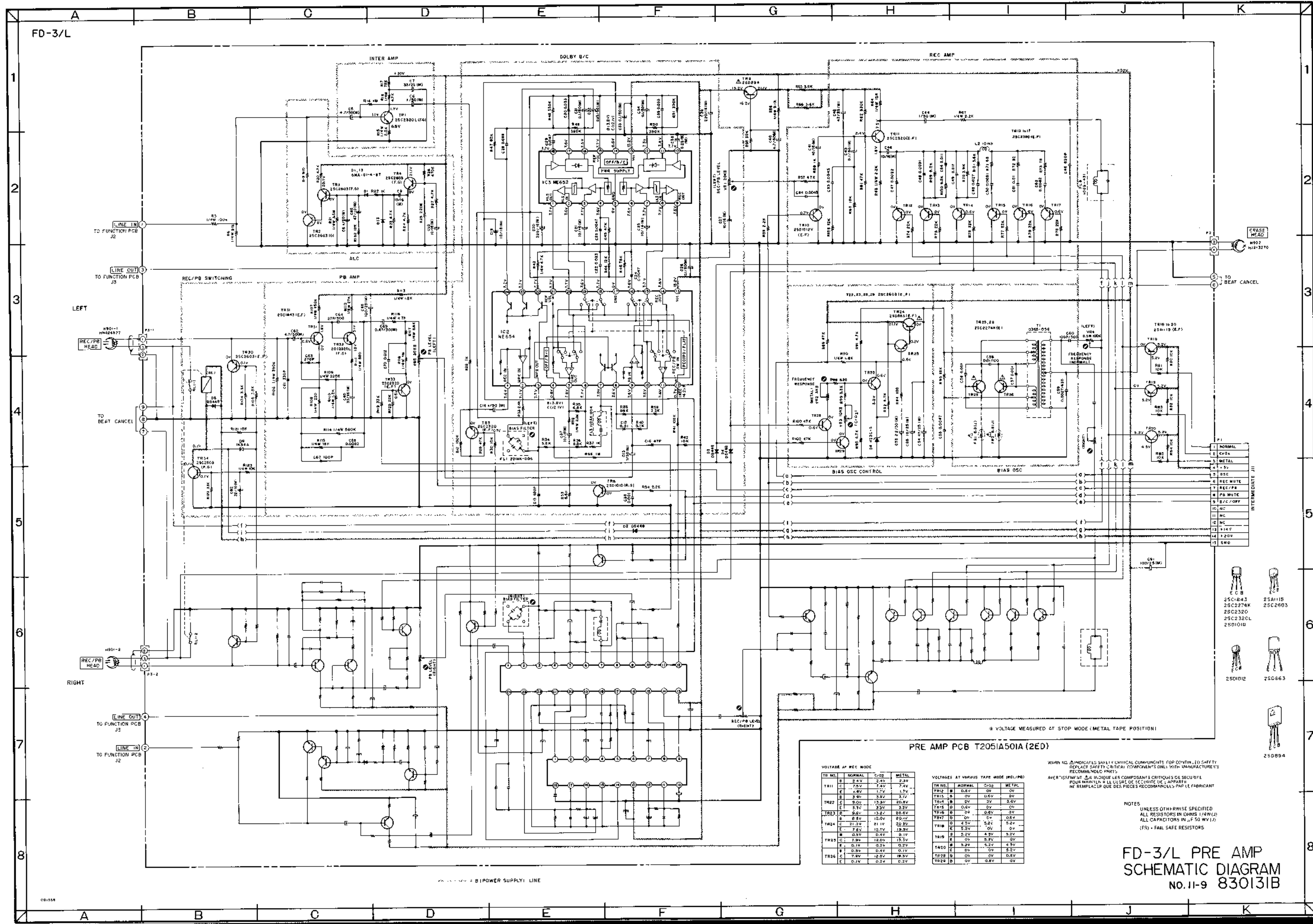

FD-3/L

LEFT

RIGHT

VOLTAGE AT REC NODE

TR NO.	NORMAL	50% METAL	2.5% METAL
TR11	2.4V	2.4V	2.4V
TR12	7.5V	7.4V	7.4V
TR13	4.8V	4.7V	4.7V
TR14	3.9V	3.7V	3.7V
TR15	8.0V	13.3V	20.8V
TR16	3.3V	3.3V	3.3V
TR17	8.8V	13.2V	20.6V
TR18	8.8V	10.0V	20.1V
TR19	21.2V	21.1V	20.2V
TR20	2.8V	15.1V	19.3V
TR21	0.5V	0.4V	0.1V
TR22	0.9V	12.0V	15.3V
TR23	0.1V	0.2V	0.2V
TR24	0.5V	0.4V	0.1V
TR25	7.8V	12.0V	19.3V
TR26	0.1V	0.2V	0.2V

VOLTAGES AT VARIAS TAPE HEAD (REL-PM)

TR NO.	NORMAL	50% METAL	2.5% METAL
TR12	0.5V	0V	0V
TR13	0V	0.6V	0V
TR14	0V	3V	3.5V
TR15	0.6V	0V	0V
TR16	0V	0.6V	0V
TR17	0V	0V	0.6V
TR18	4.5V	5.4V	2.4V
TR19	5.2V	4.9V	5.2V
TR20	0V	5.2V	4.9V
TR21	0V	0V	5.2V
TR22	0V	0V	0.6V
TR23	0V	0.6V	0V

WARN: DO NOT INDICATED SAFETY CRITICAL COMPONENTS FOR CONTINUED SAFETY. REPLACE SAFETY CRITICAL COMPONENTS ONLY WITH MANUFACTURER'S RECOMMENDED PARTS.
 AVERTISSEMENT: NE PAS INDIQUER LES COMPOSANTS CRITIQUES DE SECURITE. REMPLACER SEULEMENT LES PIECES CRITIQUES DE SECURITE PAR LES PIECES RECOMMANDEES PAR LE FABRICANT.

NOTES
 UNLESS OTHERWISE SPECIFIED
 ALL RESISTORS IN OHMS (1/4W/1%)
 ALL CAPACITORS IN μF (50 WV/1%)
 (FR) - FAIL SAFE RESISTORS

FD-3/L PRE AMP SCHEMATIC DIAGRAM No. 11-9 83013B

- 1 NORMAL
- 2 CASH
- 3 METAL
- 4 1.5V
- 5 BSC
- 6 REC MUTE
- 7 REC/PB
- 8 PB MUTE
- 9 REC OFF
- 10 NC
- 11 NC
- 12 NC
- 13 14V
- 14 120V
- 15 SW0

- ECB
- 25C1843
- 25C2274K
- 25C2320
- 25C232CL
- 25D101B
- 25D1012
- 25D663
- 25D894

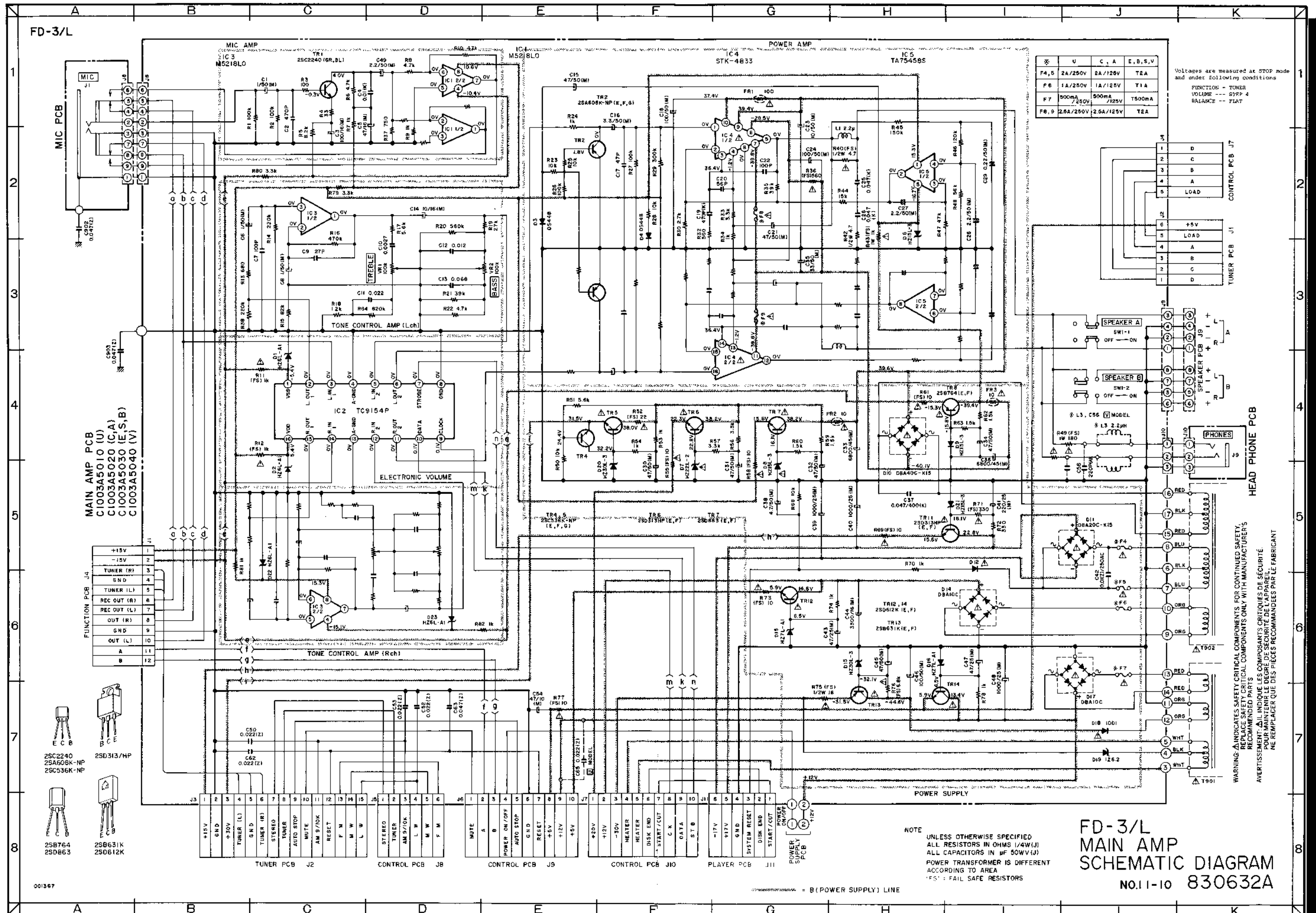

FD-3/L

FRONT END FE391U13 (ALL MODELS EXCEPT V MODEL)

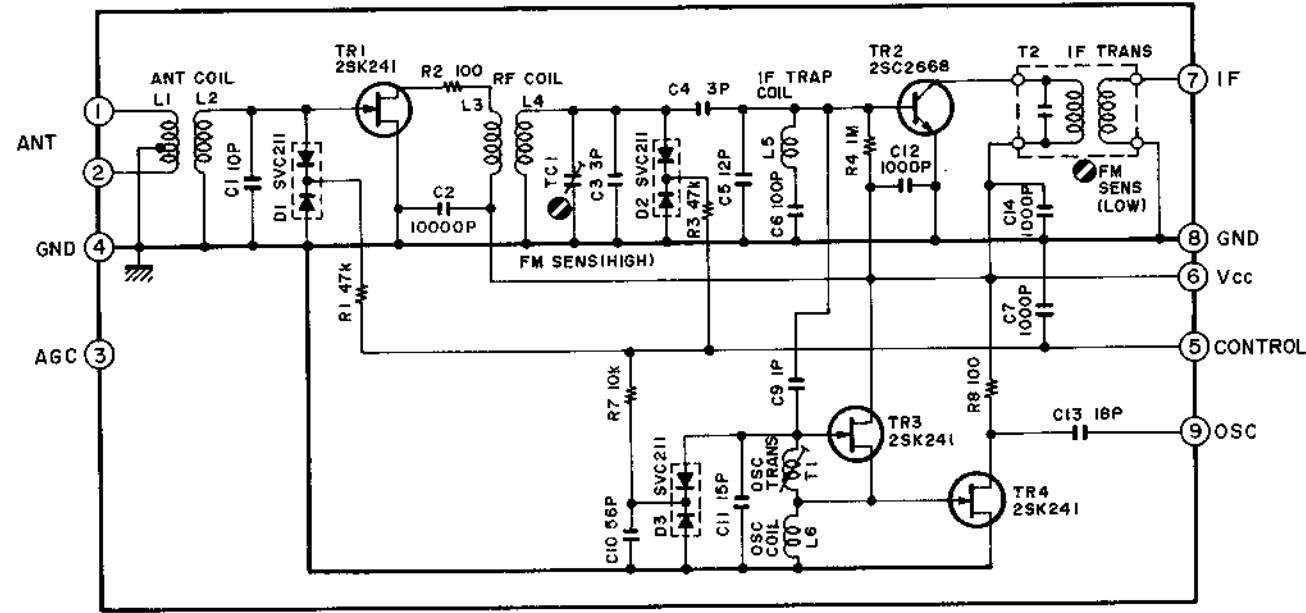

FRONT END FE393E12 (V MODEL)

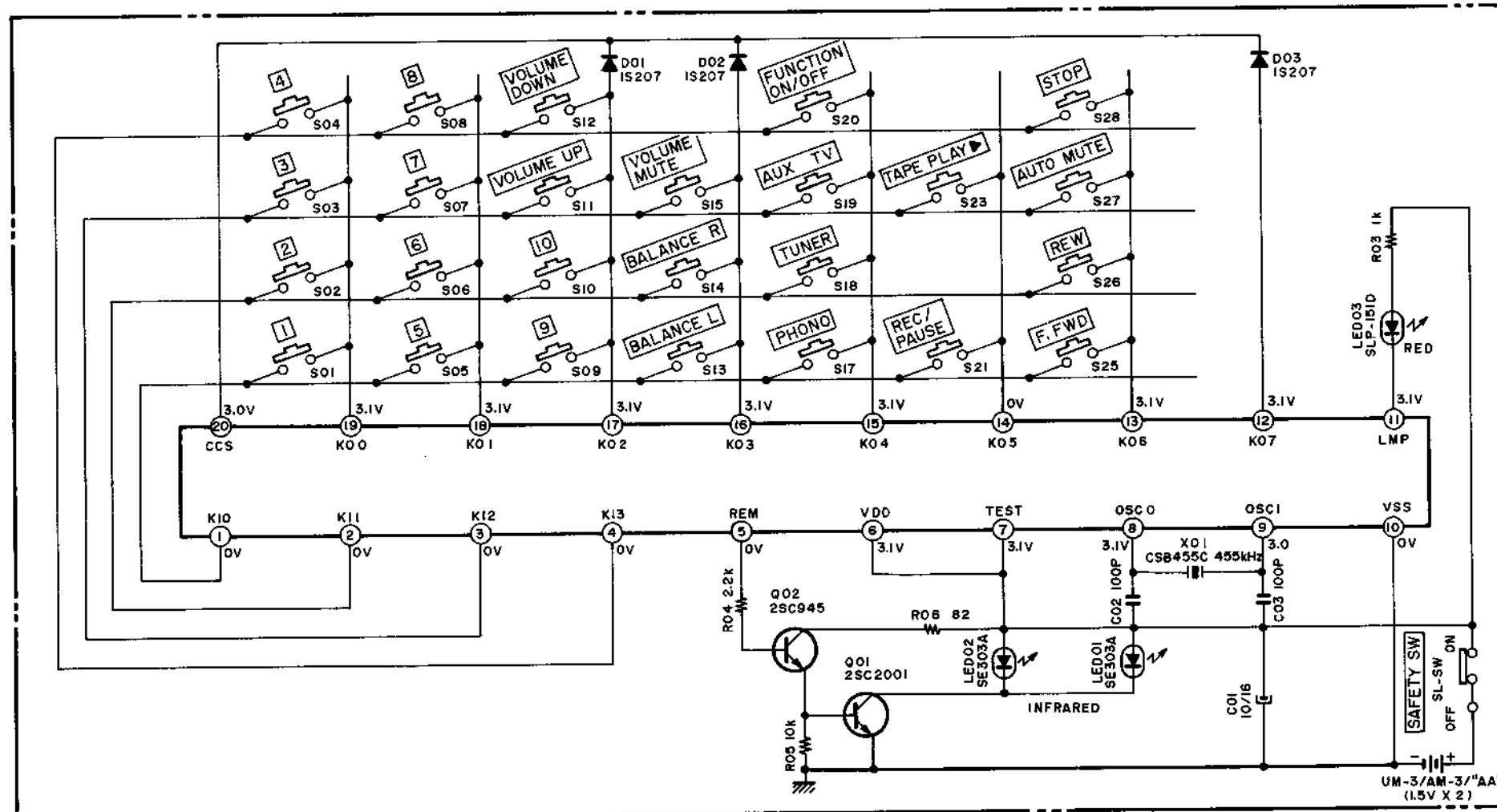
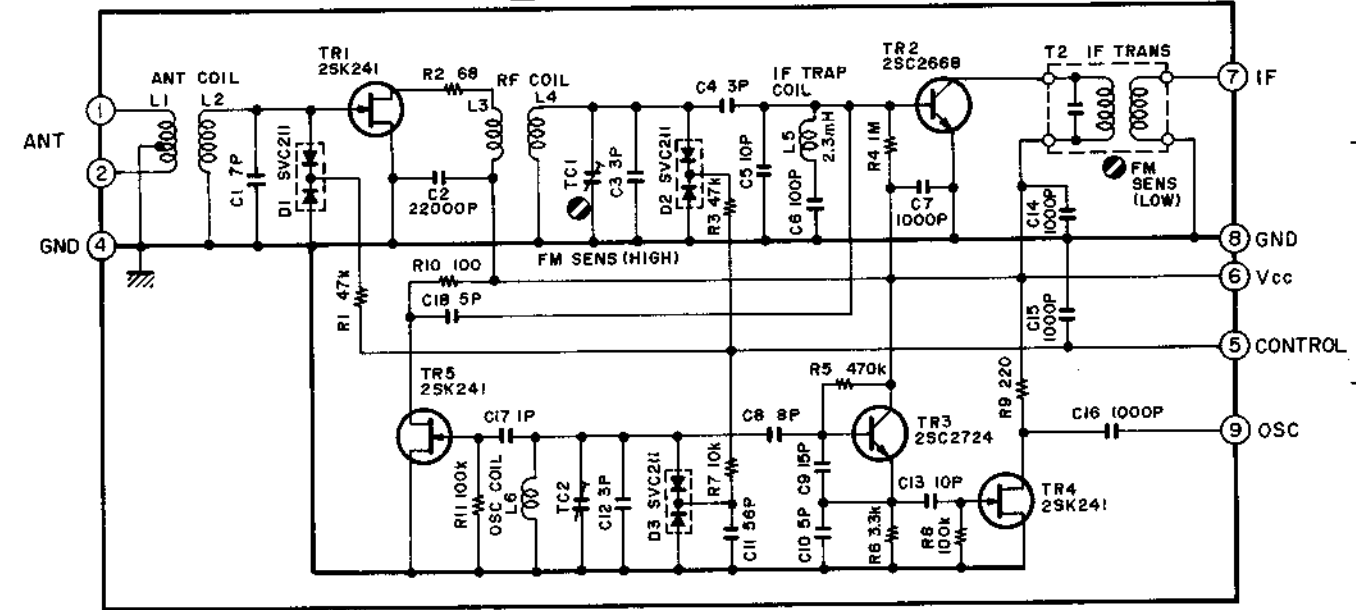

REMOTE CONTROL P.C.B 12KH107A
(FD-3/L REMOTE CONTROL UNIT KHHFA032)

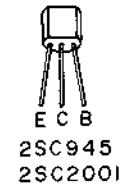

NOTES
UNLESS OTHERWISE SPECIFIED
ALL RESISTORS IN OHMS 1/4W(J)
ALL CAPACITORS IN μ F 50 WV (J)

FD-3/L
FRONT END/REMOCON
SCHEMATIC DIAGRAM
No.11-11 830633A

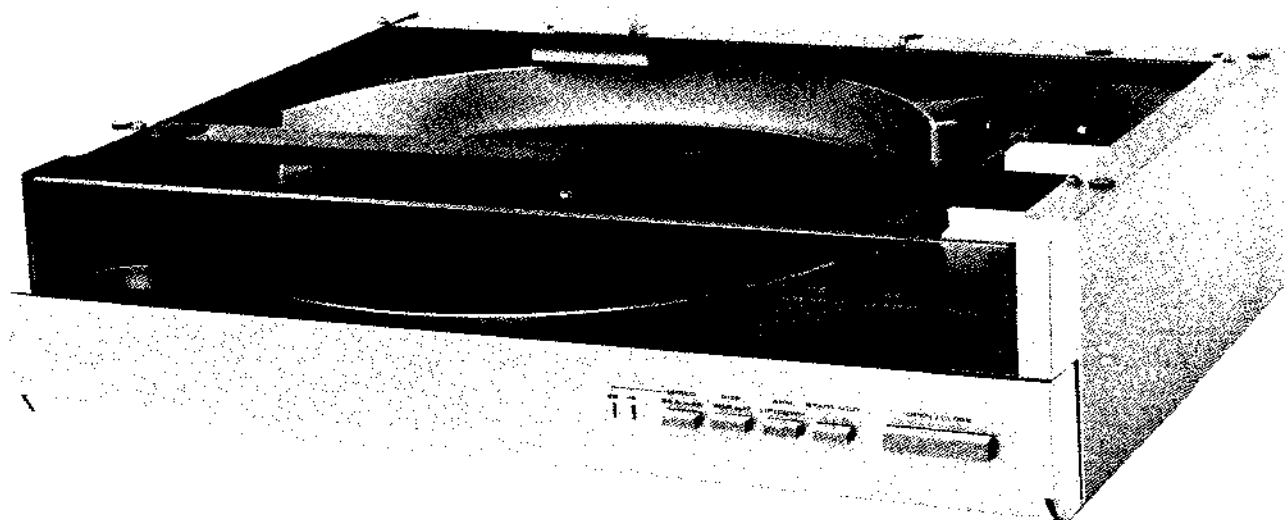

SECTION 2

SERVICE MANUAL

MODEL FP-3

TABLE OF CONTENTS

I.	SPECIFICATIONS	22
II.	DISMANTLING OF UNIT	23
III.	CONTROLS	24
IV.	PRINCIPAL PARTS LOCATION	25
V.	ADJUSTMENT	26
	1. HORIZONTAL ADJUSTMENT	26
	2. TONE ARM HEIGHT ADJUSTMENT	26
	3. LEAD IN/LEAD OUT POSITION ADJUSTMENT	26
	4. SPEED ADJUSTMENT	27
VI.	CLASSIFICATION OF VARIOUS P.C BOARDS	28
	1. P.C BOARD TITLES AND IDENTIFICATION NUMBERS	28
	2. COMPOSITION OF VARIOUS P.C BOARDS	29

For basic adjustments, measuring methods, and operating principles, refer to GENERAL TECHNICAL MANUAL.

I . SPECIFICATION ION

TURNTABLE SECTION

DRIVE SYSTEM & MECHANISM	Belt Drive, Fully Automatic, Front Loading System
MOTORS	Electronically speed controlled DC motor × 1 DC motor for Loading system × 1
SPEED	33-1/3 rpm, 45 rpm
WOW AND FLUTTER	0.04% (WRMS)
RUMBLE	73 dB (DIN 8)
CARTRIDGE	YM Type
REPLACEMENT STYLUS	RS-83

* For improvement purposes, specifications and design are subject to change without notice.

II. DISMANTLING OF UNIT

In case of trouble, etc. necessitating dismantling, please dismantle in the order shown in the photographs. Reassemble in reverse order.

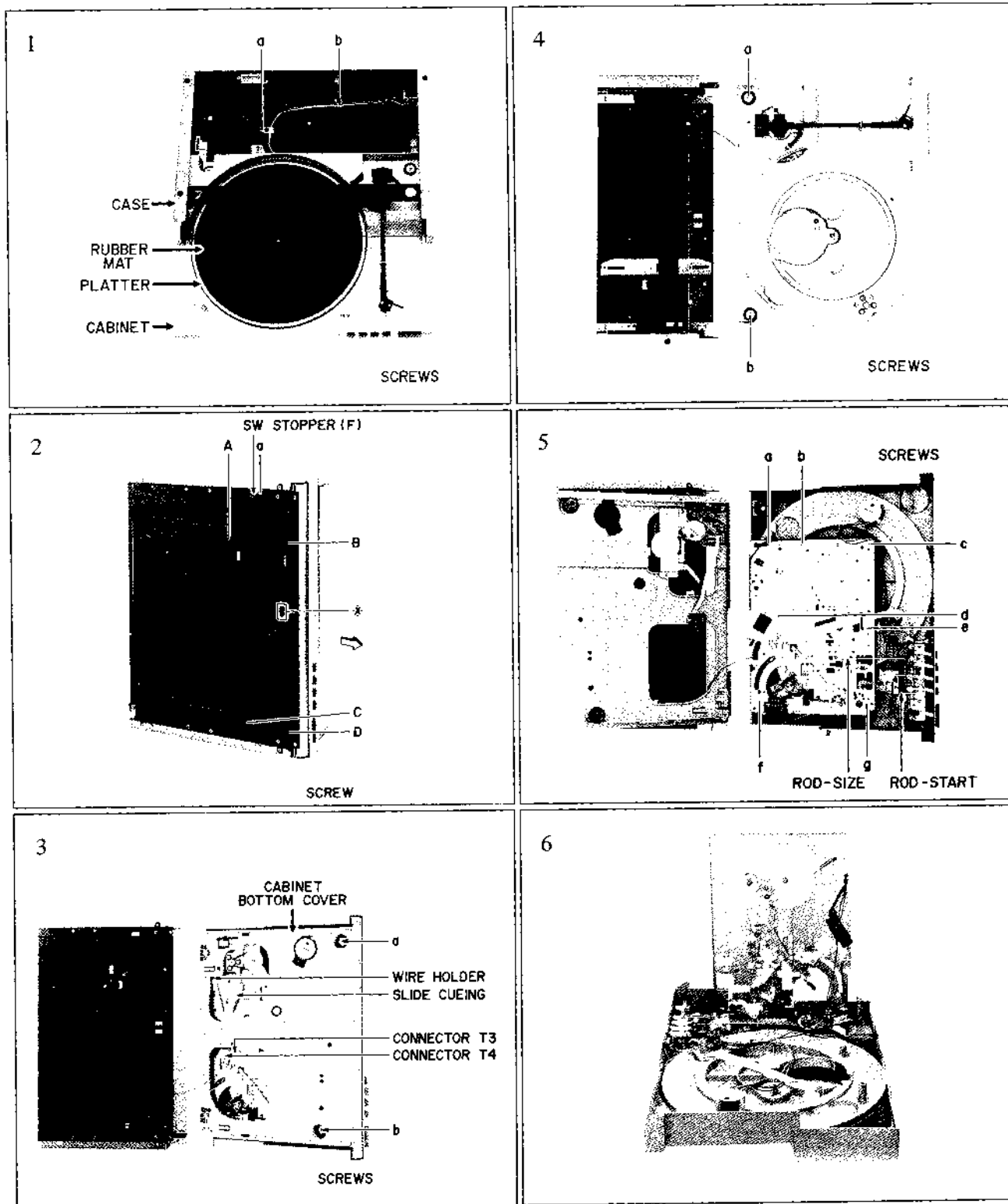

III. CONTROLS

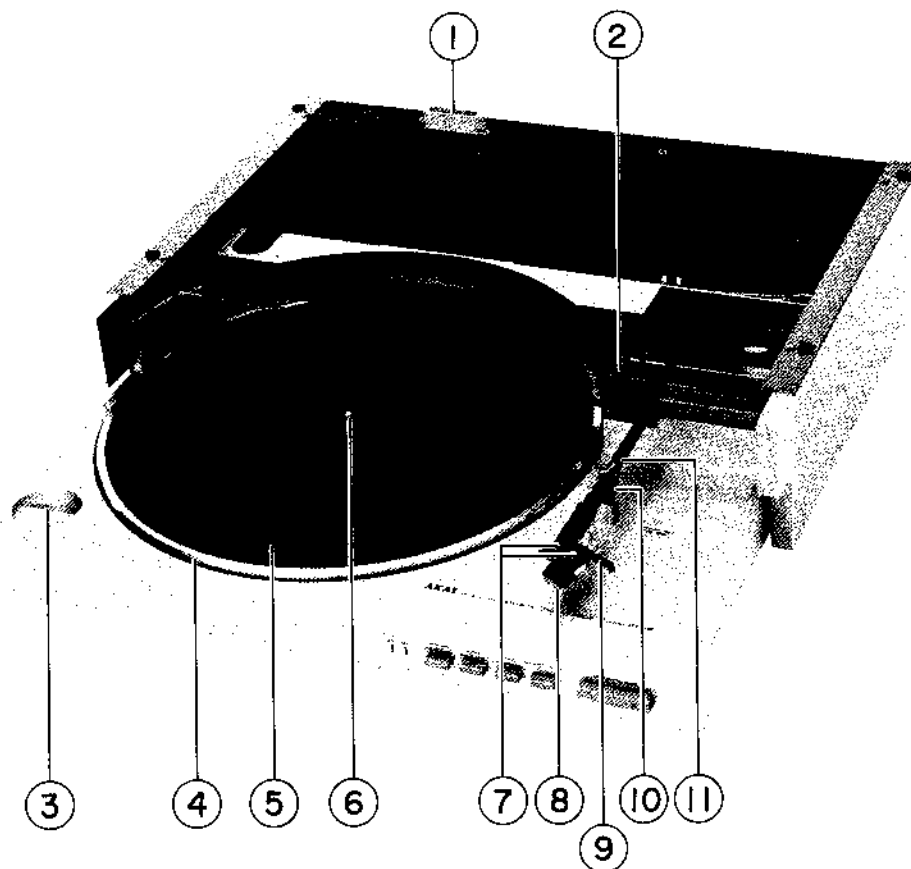

Fig. 3-1

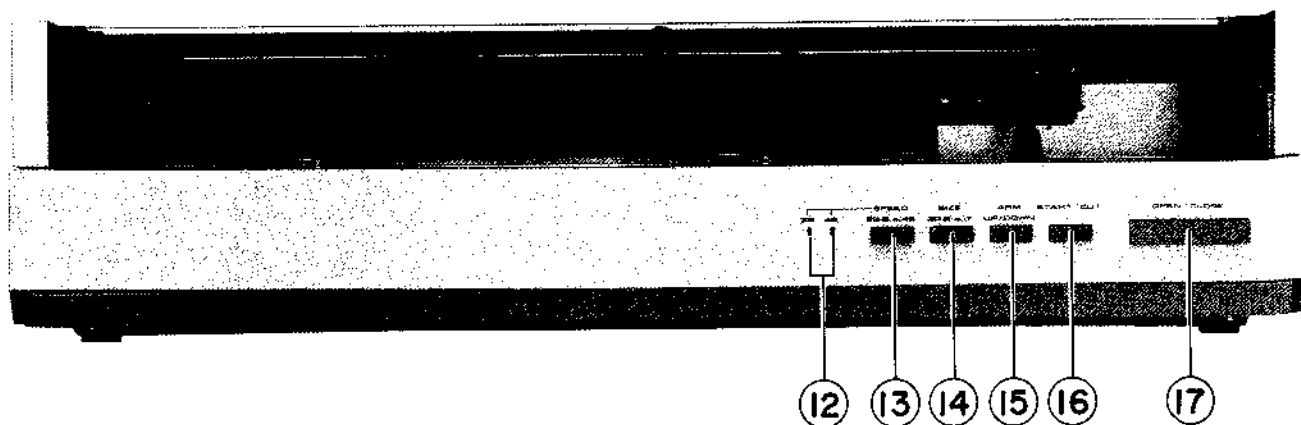

Fig. 3-2

- | | |
|--------------------------------|-----------------------------|
| 1. POWER CONNECTOR | 10. TONE ARM REST AND CLAMP |
| 2. ARM LIFTER | 11. TONE ARM |
| 3. 45 RPM ADAPTER HOLDER | 12. SPEED INDICATORS |
| 4. PLATTER | 13. SPEED SELECTOR |
| 5. RUBBER MAT | 14. SIZE SELECTOR |
| 6. SPINDLE | 15. ARM UP/DOWN SWITCH |
| 7. OVER HANG ADJUSTMENT SCREWS | 16. START/CUT BUTTON |
| 8. CARTRIDGE (WITH STYLUS) | 17. OPEN/CLOSE BUTTON |
| 9. HEADSHELL | |

IV. PRINCIPAL PARTS LOCATION

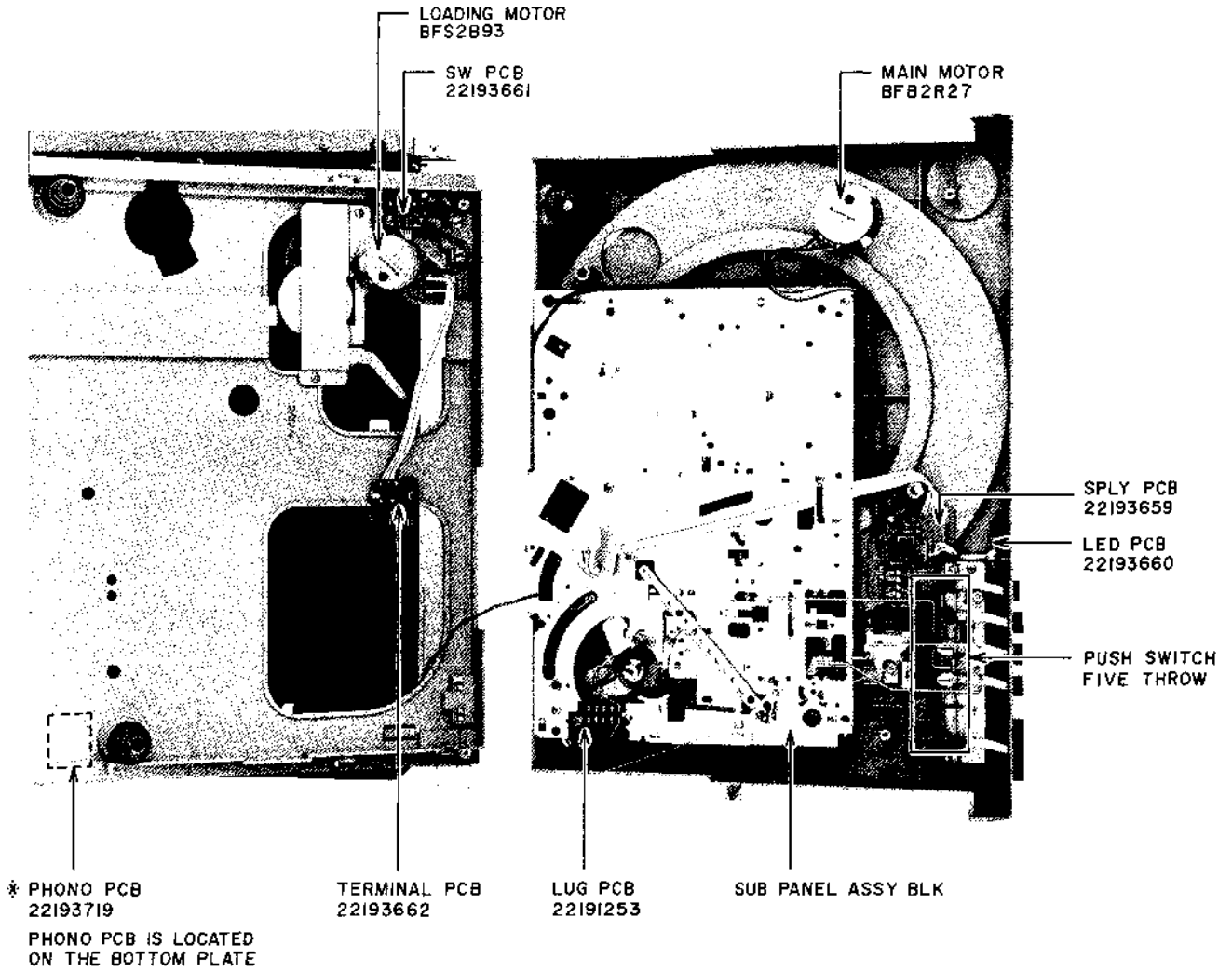

Fig. 4-1

V. ADJUSTMENT

5-1. HORIZONTAL ADJUSTMENT

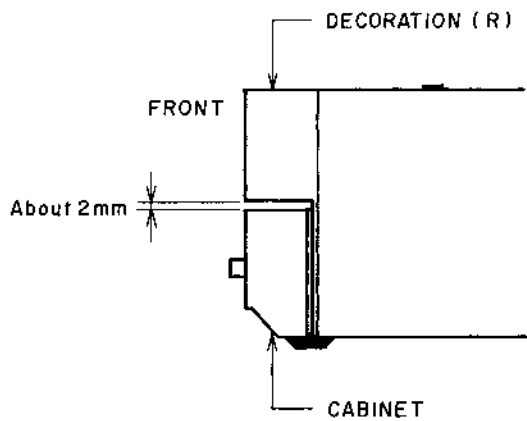

Fig. 5-1 Right Side View

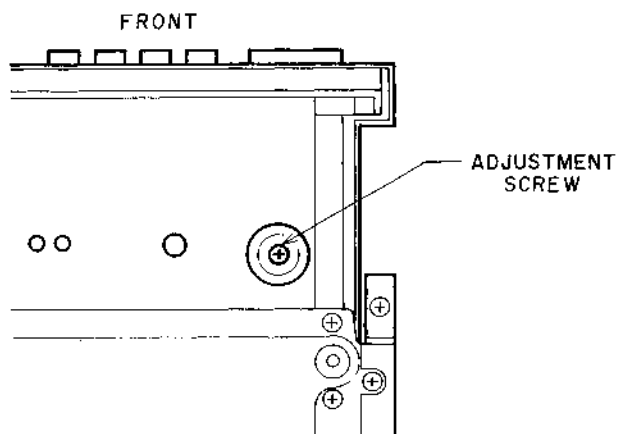

Fig. 5-2 Adjustment Point

Adjust the Adjustment screw which located bottom (refer to Fig. 5-2) so that the space between Decoration (R) and Cabinet is about 2mm.

5-2. TONE ARM HEIGHT ADJUSTMENT

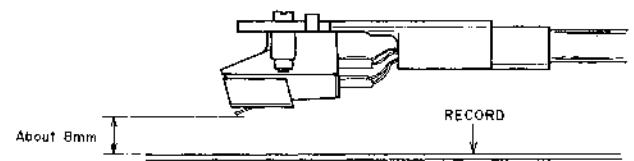

Fig. 5-3

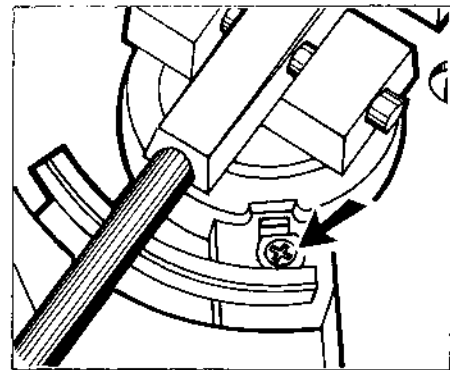

Fig. 5-4 Adjustment Point

With tone arm in the up-position, (tone arm is on the arm lifter), the stylus should be about 8mm above from the surface of the record. Turn the adjustment screw to change the height.

Clockwise: down

Counterclockwise: up

5-3. LEAD IN/LEAD OUT POSITION ADJUSTMENT

- 1) Place a record on the platter. (Use a 30cm record.)
- 2) Auto-play the record and confirm where the stylus descends.
- 3) Depress the START/CUT button to Return the Tone arm to Tone arm Rest.
- 4) IF the Stylus does not descends within the Lead-in aria. Adjust, Lead in/Lead out Adjustment screw with a screw driver,
Clockwise: To make the Stylus descend towards the spindle.
Counterclockwise: To make the Stylus descend away from the spindle.
- 5) The proper Adjustment of the Lead in position will automatically Adjust the proper Lead out position.

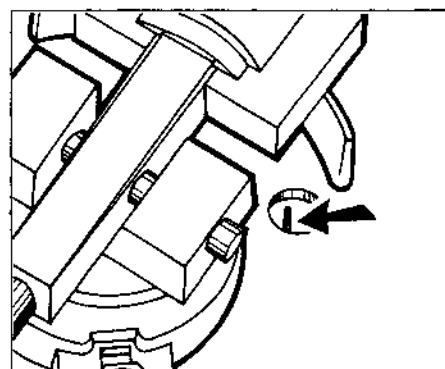

Fig. 5-5 Adjustment Point

NOTE: Do not turn the screw to far carry out the adjustment a little at a time and confirm the position after each adjustment.

5-4. SPEED ADJUSTMENT

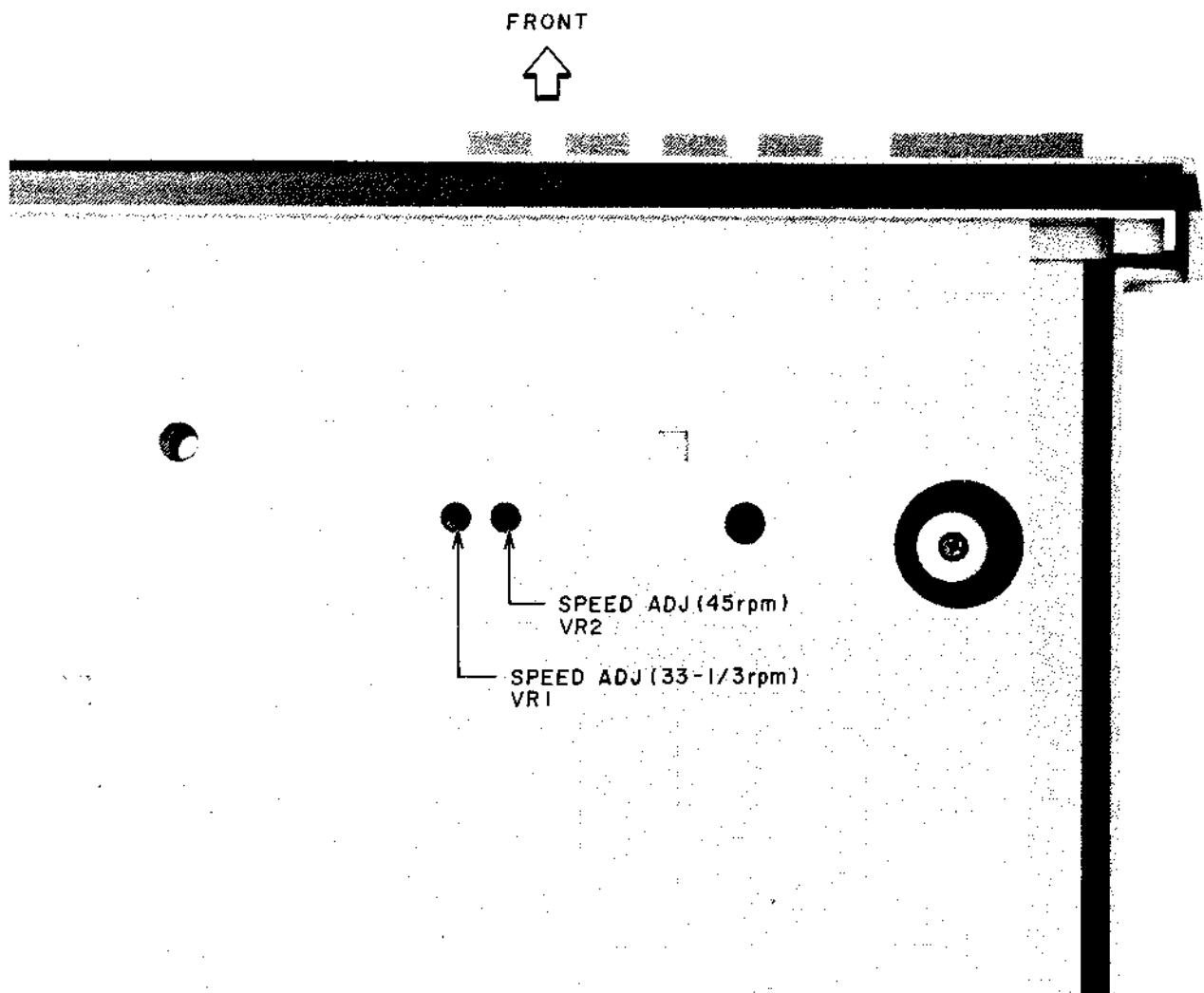

Fig. 5-6 Adjustment Point

- 1) Set the speed selector to 33-1/3 rpm.
- 2) Play Back the Test Record (33-1/3rpm, 1,000Hz).
- 3) Adjust VR1 (5KB), so that the Speed is $1,000 \pm 5\text{Hz}$.
- 4) Set the Speed Selector to 45rpm.
- 5) Play Back the Test Record (45rpm, 1,000Hz).
- 6) Adjust VR2 (10KB), so that the Speed is $1,000 \pm 5\text{Hz}$.

VI. CLASSIFICATION OF VARIOUS P.C BOARDS

6-1. P.C BOARD TITLES AND IDENTIFICATION NUMBERS

P.C BOARD TITLE		P.C BOARD NUMBER
SPLY	P.C Board	22193659
LED	P.C Board	22193660
SW	P.C Board	22193661
TERMINAL	P.C Board	22193662
LUG	P.C Board	22191253
PHONO	P.C Board	22193719

6-2. COMPOSITION OF VARIOUS P.C BOARDS

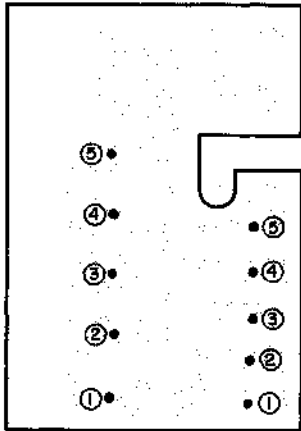

PHONO PCB 22193719

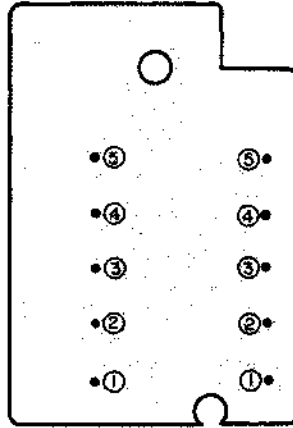

LUG PCB 22191253

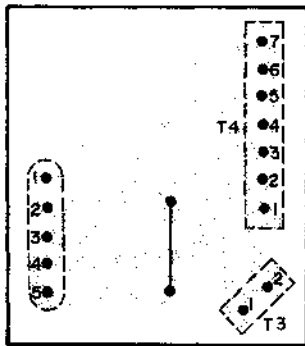

TERMINAL PCB 22193662

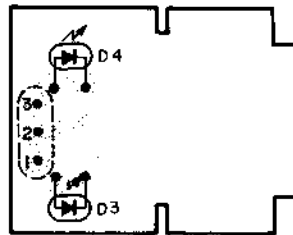

LED PCB 22193660

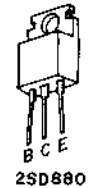

2SD880

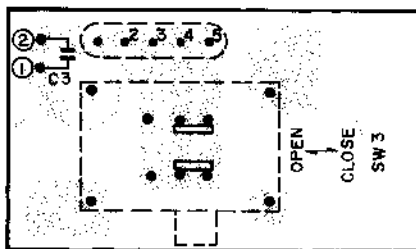

SW PCB 22193661

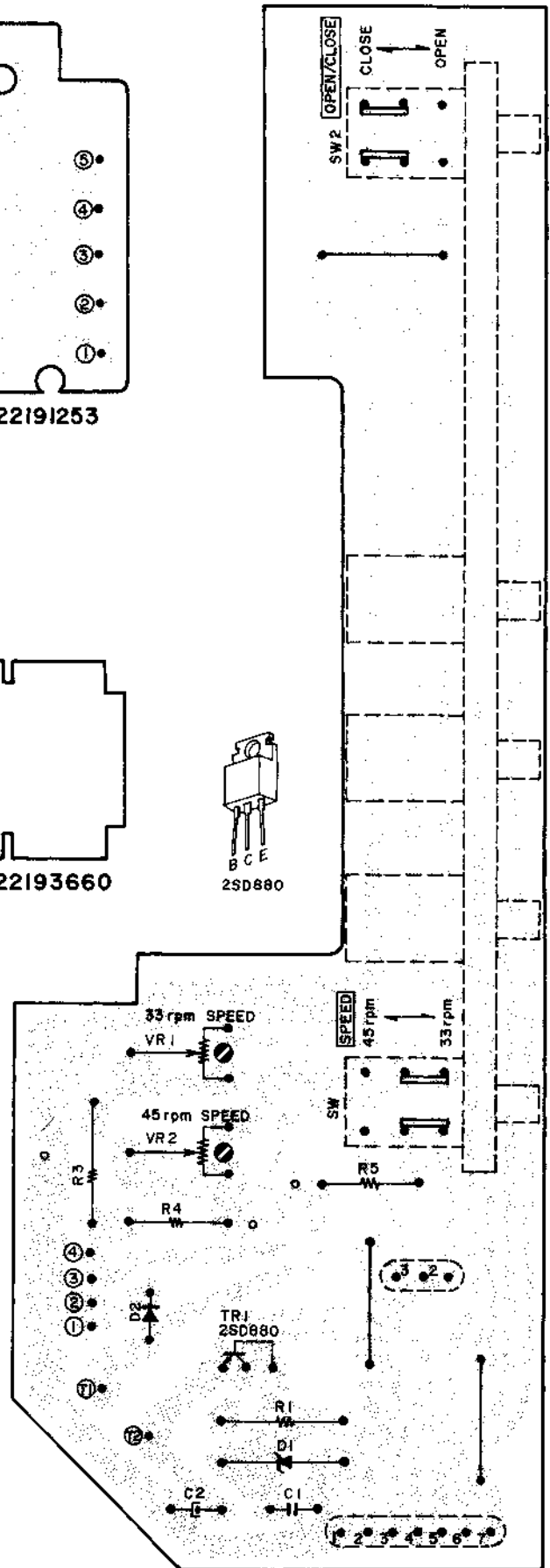

SPLY PCB 22193659

SECTION 3

PARTS LIST

TABLE OF CONTENTS

I. MODEL FD-1

RECOMMENDED SPARE PARTS..... 33

1. MECHA BLOCK 34

2. AF P.C BOARD BLOCK 36

3. RADIO P.C BOARD BLOCK 37

4. CONTROL P.C BOARD BLOCK 37

5. ASSEMBLY BLOCK..... 38

6. FINALY ASSEMBLY BLOCK 39

II. MODEL FP-3

1. P.C BOARD BLOCK 41

2. MECHA AND FA CHASSIS BLOCK 41

3. ASSEMBLY BLOCK..... 42

4. CABINET BLOCK 43

INDEX 44

Resistor and Capacitor which is not listed in this parts list, please refer to
COMMON LIST FOR SERVICE PARTS.

ATTENTION

1. When placing an order for parts, be sure to list the parts no., model no., and description. There are instances in which if any of this information is omitted, parts cannot be shipped or the wrong parts will be delivered.
2. Please be careful not to make a mistake in the parts no. If the parts no. is in error, a part different from the one ordered may be delivered.
3. Because parts numbers and parts not supply in the Preliminary Parts List may be partially changed, please use this parts list for all future reference.

HOW TO USE THIS PARTS LIST

1. This Parts List shows the parts that are considered necessary for repairs. Other parts, such as resistors and capacitors, are shown in the "Common List for Service Parts". Select and order such parts from the "Common List for Service Parts".
2. The Recommended Spare Parts shows those parts in the Parts List which are considered particularly important for service.
3. Parts not shown in the Parts List and "Common List for Service Parts" will not be supplied in principle.
4. How to read list
 - a) Mechanism Block
 - b) P.C Board Block

2. HEAD BASE BLOCK

REF. NO.	PARTS NO.	DESCRIPTION
2-1x	BH-T2023A320A	HEAD BASE BLOCK GX-F66R
2-2	HP-H2206A010A	HEAD R/P PR4-8FU C
2-3	ZS-477876	PAN20x03STL CMT
2-4	ZS-536488	BID20x08STL CMT
2-5	ZG-402895	CS ANGLE ADJUST SPRING

- SP (Service Parts) Classification
- A small "x" indicates the inability to show that particular part in the Photo or Illustration.
- This number corresponds with the individual parts index number in that figure
- This number corresponds with the Figure Number

6. SYS. CON. P.C BOARD BLOCK

REF. NO.	PARTS NO.	DESCRIPTION
6-1	BA-T2034A070A	PC SYS CON BLK GX-F44R
6-IC1	EI-324536	IC HD14049BP
6-IC2	EI-336801	IC MB8841-564M
6-IC3	EI-331661	IC SN7405N
6-IC4	EI-336725	IC M54527P
6-TR1to4	ET-200985	TR 2SC2603 F,G
6-TR5to28	ET-554657	TR 2SA733A P,Q
6-D1	ED-318292	D SILICON H 1S2473T-77 T26
6-D2to4	ED-308952	D GERMA V 1K34A-LR F07
6-D5to10	ED-318292	D SILICON H 1S2473T-77 T26
6-X1	EI-318384	OSC X'TAL NC-18C 3.579545MHZ

- SP (Service Parts) Classification
- This reference numbers corresponds with symbol numbers of Schematic Diagrams.

5. Both the kind of part and installation position can be determined by the Parts Number. To determine where a parts number is listed, utilize Parts Index at end of Parts List. It is necessary first of all to find the Parts Number. This can be accomplished by using the Reference Number listed at right of parts number in the Parts Index.

WARNING

▲ INDICATES SAFETY CRITICAL COMPONENTS FOR CONTINUED SAFETY. REPLACE SAFETY CRITICAL COMPONENTS ONLY WITH MANUFACTURE'S RECOMMENDED PARTS

AVERTISSEMENT

▲ IL INDIQUE LES COMPOSANTS CRITIQUES DE SECURITE. POUR MAINTENIR LE DEGRE DE SECURITE DE L'APPAREIL, NE REMPLACER QUE DES PIECES RECOMMANDEES PAR LE FABRICANT

I . MODEL FD-1

RECOMMENDED SPARE PARTS

Because, if the parts listed below are on hand, almost any repair can be accomplished, we suggest that you stock these Recommended Spare Parts Items.

REF. NO.	PARTS NO.	DESCRIPTION
1	BF-711395	FLYWHEEL ASSY
2	BL-711389	PINCH ROLLER LEVER ASSY
3	BM-711391	MOTOR MAIN (W/PULLEY)
4	BM-711410	MOTOR REEL (W/PULLEY)
5	BT-709396	△ TRANS POWER FD-1 (U)
6	BT-711442	△ TRANS POWER FD-1 (C)
7	BT-711444	△ TRANS POWER FD-1 (S)
8	BT-709406	TRANS IFT AM-M-CE
9	BT-709407	TRANS IFT FM-D
10	EC-711437	C S-FIX
11	EC-749457	C S-FIX
12	EC-709431	C S-FIX R
13	ED-707776	△ D SILICON S1WB-10
14	ED-703290	△ D DIODE S2VB10
15	ED-709421	D LED AA5527S-1
16	ED-701131	D LED LN-317GP
17	ED-703243	D LED LN217RP
18	ED-709420	D LED LN29RP
19	ED-701124	D LED LN328GP
20	ED-709419	D LED LN410YP
21	ED-703310	D LED LN417YP
22	ED-709441	D LED SG238W
23	ED-306724	D SILICON S5277B 100/1.0A
24	ED-702236	D SILICON 1S1553V
25	ED-703195	D SILICON 1S1555V-TP3
26	ED-327098	D ZENER HWZ-061
27	ED-539976	D ZENER HWZ-130
28	ED-709426	D ZENER WZ042
29	ED-707934	D DIODE WZ048
30	EF-711445	△ FUSE 1.5A
31	EF-702200	△ FUSE 1S-T
32	EI-709399	IC AN7223
33	EI-213390	IC NJM4558D
34	EI-709422	IC NJM4562DD
35	EI-709427	IC TA7341P
36	EI-709247	IC TA7629P
37	EI-305456	IC TC409 UBC
38	EI-709428	IC TC9143P
39	EI-344436	IC TC9147P
40	EI-344437	IC TD6301AP
41	EI-709439	IC TL072-D
42	EI-702184	IC UPC1188H
43	EI-701061	IC UPC1197C
44	EJ-709432	JACK 6.5ST
45	EI-702181	TERMINAL 4P
46	EJ-749374	JACK US6P
47	EM-709415	IND FL FIP7A8S
48	EO-741909	AF CHOKE COIL AC-3750
49	EO-711436	COIL ANT LW
50	EO-709405	COIL ANT MW
51	EO-709425	COIL CHOKE AF 12MH
52	EO-702240	COIL CHOKE AF 4.70MH
53	EO-709404	COIL CHOKE 221
54	EO-742246	COIL FM-CHOKE
55	EO-709409	COIL MPX
56	EO-709430	COIL OSC AF
57	EO-711435	COIL OSC MW
58	EO-709414	OSC X'TAL
59	EP-711418	SOLENOID PLAY
60	ER-749371	△ R FUSE 1/4W R22
61	ER-749372	△ R FUSE 1/4W R47
62	ER-704152	△ R FUSE 1/4W 220J
63	ER-709408	FILTER CE
64	ER-709423	FILTER DOLBY
65	ER-711438	R COMP 153 7P
66	ER-711439	R COMP 183 7P
67	ER-711440	R COMP 223 7P
68	ES-709398	△ SW SLIDE
69	ES-711419	SW CASSETTE
70	ES-709418	SW KEY
71	ES-709416	SW PUSH
72	ES-709417	SW PUSH
73	ES-709440	SW PUSH
74	ES-709433	SW PUSH 4 THROW
75	ES-709438	SW PUSH 4 THROW
76	ES-709444	SW SLIDE
77	ES-709453	SW SLIDE
78	ET-741953	△ TR 2SD325-E
79	ET-336864	TR FET 2SK223 F
80	ET-337759	TR FET 2SK246 GR
81	ET-337604	TR FET 2SK246 Y
82	ET-741903	TR 2SA1015-GR
83	ET-328861	TR 2SA562TM O,Y
84	ET-306720	TR 2SA966 O,Y
85	ET-741941	TR 2SC1627A-Y
86	ET-330225	TR 2SC1815 BL
87	ET-325482	TR 2SC1959 Y
88	ET-711433	TR 2SC2236Y
89	ET-702700	TR 2SC380TM O
90	ET-709429	TR 2SD1140
91	ET-338565	TR 2SD1302 R,S
92	ET-709400	TR 2SK192A-Y
93	EV-703298	R S-FIX 103
94	EV-706603	R S-FIX 103
95	EV-703279	R S-FIX 503
96	EV-703299	SEMI-FIXED/VOL. 500 OHMS
97	EV-709434	VR SLIDE 60B-204-D
98	EV-709436	VR SLIDE 45W 204
99	HE-711380	HEAD E
100	HP-711381	HEAD R/P
101	MB-709443	BELT COUNTER
102	MB-711409	BELT MAIN MOTOR
103	MT-711377	REEL DRUM
104	MV-711398	CAPSTAN METAL CASE
105	ZG-711390	SP PINCH ROLLER LEVER

MECHA BLOCK (1/2)

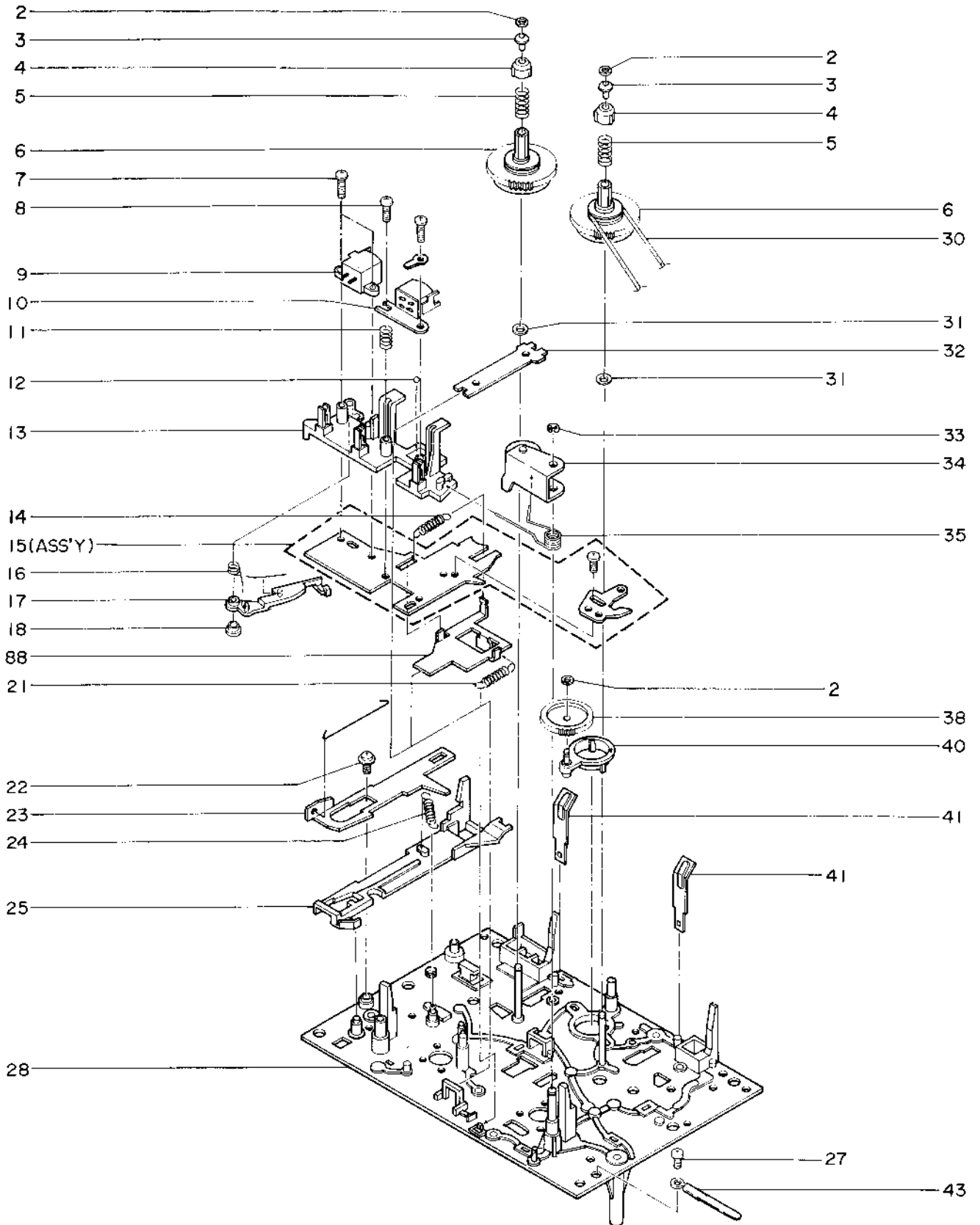

(2/2)

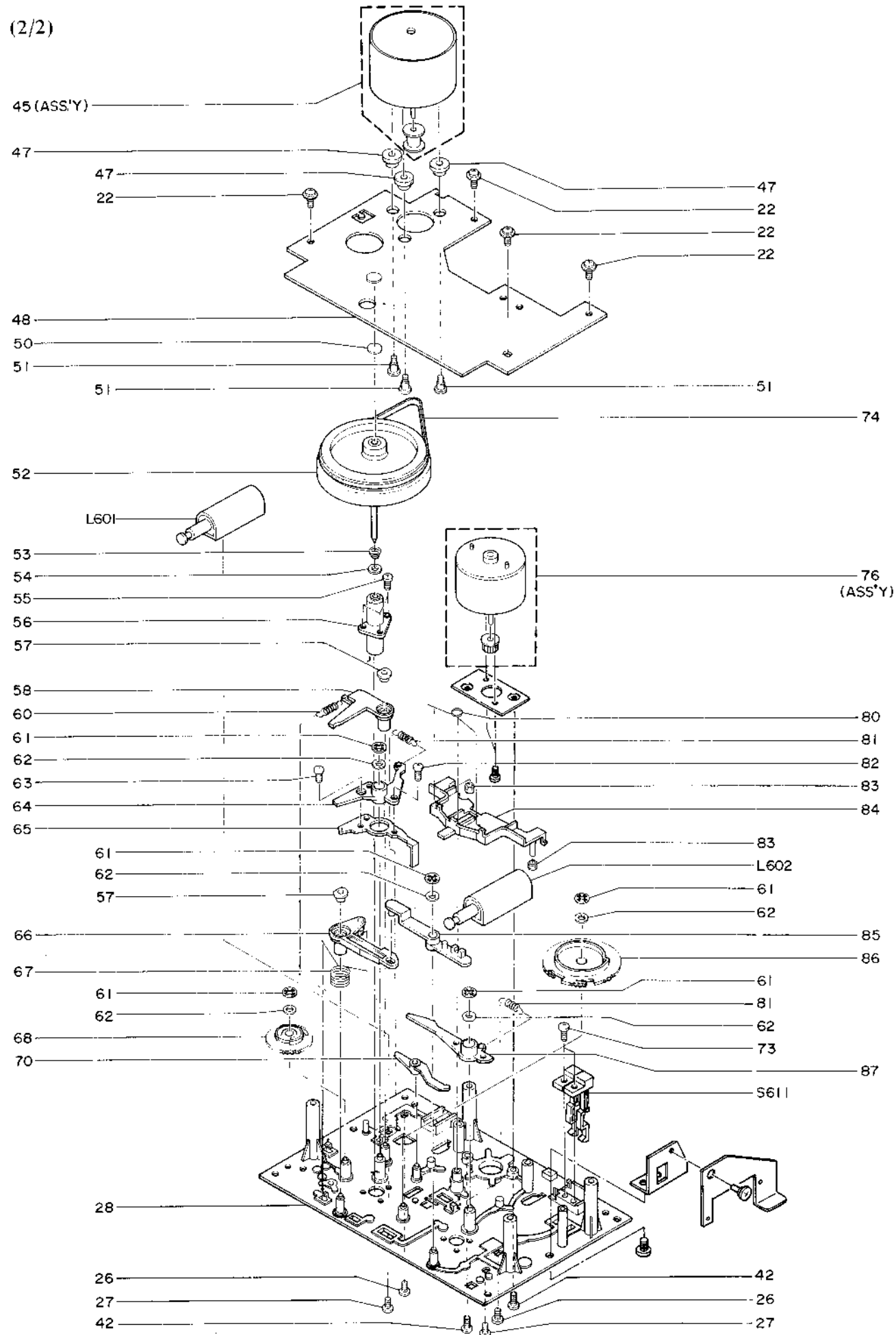

1. MECHA BLOCK

REF. NO.	PARTS NO.	DESCRIPTION
1-1	BB-711481	MECHA BLK MU-601FT
MECHA BLOCK (1/2)		
1-2	ZW-711373	WASHER
1-3	MT-711374	CAP REEL
1-4	MT-711375	COLLAR REEL
1-5	ZG-711376	SP REEL
1-6	MT-711377	REEL DRUM
1-7	ZS-711378	SCREW
1-8	ZS-711379	SCREW
1-9	HF-711380	HEAD E
1-10	HP-711381	HEAD R/P
1-11	ZG-703359	SP HEAD
1-12	MV-711382	BALL
1-13	HA-711383	HEAD BASE
1-14	ZG-711384	SP HEAD CHASSIS
1-16	ZG-711385	SP ERASE LEVER
1-17	ML-711386	LEVER ERASE ASSY
1-30	MB-709443	BELT COUNTER
1-33	ZW-711388	E RING
1-34	BL-711389	PINCH ROLLER LEVER ASSY
1-35	ZG-711390	SP PINCH ROLLER LEVER

MECHA BLOCK (2/2)		
1-45	BM-711391	MOTOR MAIN (W/PULLEY)
1-47	MB-711392	CUSHION MOTOR
1-50	ZW-711393	THRUST WASHER
1-51	ZS-711394	SCREW SPL (MOTOR)
1-52	BF-711395	FLYWHEEL ASSY
1-53	ZG-711396	SP FLYWHEEL
1-54	ZW-711397	WASHER FLYWHEEL
1-56	MV-711398	CAPSTAN METAL CASE
1-57	MZ-711399	BUSH
1-58	ML-711400	LEVER LOCK PAUSE
1-60	ZG-711401	SP LOCK LEVER
1-61	ZW-711402	RING
1-64	ML-711403	LEVER PAUSE
1-66	ML-711404	LEVER LOCK PLAY
1-67	ZG-711405	SP LOCK LEVER
1-68	MZ-711406	CAM GEAR PAUSE
1-70	ML-711407	LEVER BRAKE
1-74	MB-711409	BELT MAIN MOTOR
1-76	BM-711410	MOTOR REFL (W/PULLEY)
1-80	ZG-711411	SP BRAKE SLIDER
1-81	ZG-711412	SP PLAY LEVER
1-83	MB-711413	CUSHION BRAKE SLIDER
1-84	MZ-711414	BRAKE SLIDER
1-85	ML-711415	LEVER SOLENOID
1-86	MZ-711416	CAM GEAR PLAY
1-87	ML-711417	LEVER PLAY
1-L601	EP-711418	SOLENOID PLAY
1-L602	EP-711418	SOLENOID PLAY
1-S611	ES-711419	SW CASSETTE
1-89x	MC-709442	COUNTER

Note

Parts will not be supplied if they are not listed in the parts list, even if they appear on the assembling illustrations with reference No.

2. AF P.C BOARD BLOCK

REF. NO.	PARTS NO.	DESCRIPTION
2-1U	BA-749453	PC AF BLK FD-1(U,E)
2-1C	BA-749454	PC AF BLK FD-1(C,A)
2-1S	BA-749455	PC AF BLK FD-1(S)
AF P.C BOARD		
2-IC301	EI-709422	IC NJM4562DD
2-IC303	EI-709247	IC TA7629P
2-IC304	EI-709247	IC TA7629P
2-IC451	EI-709439	IC TL072-D
2-IC501	EI-702184	IC UPC1188H
2-IC502	EI-702184	IC UPC1188H
2-TR001	ET-741953	△ TR 2SD325-E
2-TR002	ET-741953	TR 2SD325-E
2-TR301	ET-336864	TR FET 2SK223 F
2-TR302	ET-336864	TR FET 2SK223 F
2-TR303	ET-330225	TR 2SC1815 BL
2-TR304	ET-330225	TR 2SC1815 BL
2-TR305	ET-337759	TR FET 2SK246 GR
2-TR306	ET-337759	TR FET 2SK246 GR
2-TR307	ET-337759	TR FET 2SK246 GR
2-TR308	ET-337759	TR FET 2SK246 GR
2-TR309	ET-337759	TR FET 2SK246 GR
2-TR310	ET-337759	TR FET 2SK246 GR
2-TR311	ET-330225	TR 2SC1815 BL
2-TR312	ET-330225	TR 2SC1815 BL
2-TR313	ET-330225	TR 2SC1815 BL
2-TR314	ET-330225	TR 2SC1815 BL
2-TR315	ET-338565	TR 2SD1302 R,S
2-TR316	ET-338565	TR 2SD1302 R,S
2-TR317	ET-330225	TR 2SC1815 BL
2-TR318	ET-330225	TR 2SC1815 BL
2-TR319	ET-330225	TR 2SC1815 BL
2-TR320	ET-330225	TR 2SC1815 BL
2-TR321	ET-330225	TR 2SC1815 BL
2-TR322	ET-330225	TR 2SC1815 BL
2-TR323	ET-338565	TR 2SD1302 R,S
2-TR324	ET-338565	TR 2SD1302 R,S
2-TR325	ET-337759	TR FET 2SK246 GR
2-TR326	ET-337759	TR FET 2SK246 GR
2-TR327	ET-330225	TR 2SC1815 BL
2-TR481	ET-330225	TR 2SC1815 BL
2-TR501	ET-330225	TR 2SC1815 BL
2-TR701	ET-741941	TR 2SC1627A-Y
2-TR702	ET-706720	TR 2SA966 O,Y
2-TR703	ET-330225	TR 2SC1815 BL
2-D001	ED-703290	△ D DIODE S2VB10
2-D002	ED-707776	△ D SILICON S1WB-10
2-D003	ED-709441	D LED SG238W
2-D005	ED-310578	D ZENER HWZ-177
2-D006	ED-539976	D ZENER HWZ-130
2-D007	ED-707934	D DIODE WZ048
2-D301	ED-702195	D SILICON 1S1555V-TP3
2-D302	ED-702195	D SILICON 1S1555V-TP3
2-D303	ED-702195	D SILICON 1S1555V-TP3
2-D305	ED-702195	D SILICON 1S1555V-TP3
2-D306	ED-702195	D SILICON 1S1555V-TP3
2-D307	ED-702195	D SILICON 1S1555V-TP3
2-D308	ED-702195	D SILICON 1S1555V-TP3
2-D309	ED-702195	D SILICON 1S1555V-TP3
2-D310	ED-702195	D SILICON 1S1555V-TP3
2-D311	ED-702195	D SILICON 1S1555V-TP3
2-D312	ED-709426	D ZENER WZ042
2-D313	ED-709426	D ZENER WZ042
2-D455	ED-702195	D SILICON 1S1555V-TP3
2-D456	ED-702195	D SILICON 1S1555V-TP3
2-D481	ED-702195	D SILICON 1S1555V-TP3
2-D482	ED-702195	D SILICON 1S1555V-TP3
2-D702	ED-702236	D SILICON 1S1553V
2-D703	ED-702236	D SILICON 1S1553V
2-D704	ED-702236	D SILICON 1S1553V
2-S26	ES-709433	SW PUSH 4 THROW
2-S27	ES-709438	SW PUSH 4 THROW
2-VR301	EV-703279	R S-FIX 503
2-VR302	EV-703279	R S-FIX 503
2-VR303	EV-703298	R S-FIX 103
2-VR304	EV-703298	R S-FIX 103
2-L301	ER-709423	FILTER DOLBY

REF. NO.	PARTS NO.	DESCRIPTION
2-L302	ER-709423	FILTER DOLBY
2-L303	EO-709425	COIL CHOKE AF 12MH
2-L304	EO-709425	COIL CHOKE AF 12MH
2-L305	EO-702240	COIL CHOKE AF 4.70MH
2-L306	EO-702240	COIL CHOKE AF 4.70MH
2-L701	EO-709430	COIL OSC AF
2-CT701	EC-709431	C S-FIX R
2-CT702	EC-709431	C S-FIX R
2-R001	ER-749370	R CT 10M 560K
2-R002	ER-749371	△ R FUSE 1/4W R22
2-R005	ER-324670	R OMF H SNP FS 2W 102J
2-R006	ER-305722	R OMF H SNP FS 2W 221J
2-R007	ER-333120	R OMF H SNP FS 2W 561J
2-R008	ER-333120	R OMF H SNP FS 2W 561J
2-R010	ER-749372	△ R FUSE 1/4W R47
2-R011	ER-749372	△ R FUSE 1/4W R47
2-R012	ER-749373	R OMF H FS 3W 150
2-R013	ER-336841	R OMF H SNP FS 1W 332J
2-R380	ER-704791	R FUSE 1/4W 470J
2-R511	ER-704154	R OMF FS 1W 100J
2-R512	ER-704154	R OMF FS 1W 100J
2-R553	ER-331618	R OMF H SNP FS 1W 561J
2-R710	ER-704152	△ R FUSE 1/4W 220J
2-R839	ER-333085	R OMF H SNP FS 2W 330J
2-R849	ER-329070	R OMF H SNP FS 2W 181J
2-R854	ER-658034	R OMF H FS 2W 221J
2-R857	ER-321192	R OMF H SNP FS 2W 101J
2-C003	EC-710377	C EC V 472M 30.0DC
2-C004	EC-710377	C EC V 472M 30.0DC
2-C005	EC-710378	C EC V 222M 25.0DC
2-VR452	EV-709434	VR SLIDE 60B-204-D

LOGIC P.C BOARD

2-IC801	EI-709428	IC TC9143P
2-IC802	EI-305456	IC TC4049UBC
2-IC803	EI-709427	IC TA7341P
2-TR801	ET-330225	TR 2SC1815 BL
2-TR802	ET-741903	TR 2SA1015-GR
2-TR803	ET-741903	TR 2SA1015-GR
2-TR804	ET-330225	TR 2SC1815 BL
2-TR805	ET-328864	TR 2SA562TM O,Y
2-TR806	ET-328864	TR 2SA562TM O,Y
2-TR807	ET-325482	TR 2SC1959 Y
2-TR808	ET-325482	TR 2SC1959 Y
2-TR809	ET-325482	TR 2SC1959 Y
2-TR810	ET-325482	TR 2SC1959 Y
2-TR811	ET-325482	TR 2SC1959 Y
2-TR812	ET-325482	TR 2SC1959 Y
2-TR813	ET-709429	TR 2SD1140
2-TR814	ET-325482	TR 2SC1959 Y
2-TR815	ET-709429	TR 2SD1140
2-TR816	ET-703397	TR 2SA1015 Y
2-TR817	ET-330225	TR 2SC1815 BL
2-D801	ED-702195	D SILICON 1S1555V-TP3
2-D802	ED-702195	D SILICON 1S1555V-TP3
2-D803	ED-702195	D SILICON 1S1555V-TP3
2-D804	ED-702195	D SILICON 1S1555V-TP3
2-D805	ED-702195	D SILICON 1S1555V-TP3
2-D806	ED-702195	D SILICON 1S1555V-TP3
2-D807	ED-702195	D SILICON 1S1555V-TP3
2-D808	ED-702195	D SILICON 1S1555V-TP3
2-D809	ED-702195	D SILICON 1S1555V-TP3
2-D810	ED-702195	D SILICON 1S1555V-TP3
2-D811	ED-702195	D SILICON 1S1555V-TP3
2-D812	ED-702195	D SILICON 1S1555V-TP3
2-D813	ED-702195	D SILICON 1S1555V-TP3
2-D814	ED-702195	D SILICON 1S1555V-TP3
2-D815	ED-702195	D SILICON 1S1555V-TP3
2-D816	ED-702195	D SILICON 1S1555V-TP3
2-D817	ED-702195	D SILICON 1S1555V-TP3
2-D818	ED-702195	D SILICON 1S1555V-TP3
2-D819	ED-702195	D SILICON 1S1555V-TP3
2-D820	ED-306724	D SILICON S5277B 100/1.0A
2-D821	ED-306724	D SILICON S5277B 100/1.0A
2-D822	ED-322809	D ZENER HWZ-081
2-D826	ED-702195	D SILICON 1S1555V-TP3
2-D827	ED-702195	D SILICON 1S1555V-TP3
2-D828	ED-702195	D SILICON 1S1555V-TP3
2-D829	ED-702195	D SILICON 1S1555V-TP3
2-D830	ED-702195	D SILICON 1S1555V-TP3

REF. NO.	PARTS NO.	DESCRIPTION
MIC P.C BOARD		
2-IC481	EI-213390	IC NJM4558D
2-J2	EJ-709432	JACK 6.5ST
SW P.C BOARD (A)		
2-S25	ES-709453	SW SLIDE
SW P.C BOARD (B)		
2-S28	ES-709440	SW PUSH
2-D004	ED-310578	D ZENER H WZ-177
2-R003	ER-324670	R OMF H SNP FS 2W 102J
HEAD PHONE P.C BOARD		
2-J3	EJ-709432	JACK 6.5ST
2-R513	ER-306961	R OMF H SNP FS 2W 151J
2-R514	ER-306961	R OMF H SNP FS 2W 151J
BALANCE P.C BOARD		
2-VR451	EV-709436	VR SLIDE 45W 204
JACK P.C BOARD		
2-J1	EJ-749374	JACK US6P
SP P.C BOARD		
2-J4	EJ-702181	TERMINAL 4P

3. RADIO P.C BOARD BLOCK

REF. NO.	PARTS NO.	DESCRIPTION
3-1U	BA-711430	PC RADIO BLK FD-1 (U,E,S)
3-1C	BA-711431	PC RADIO BLK FD-1 (C,A)
RADIO P.C BOARD		
3-IC201	EI-709399	IC AN7223
3-IC202	EI-701061	IC UPC1197C
3-IC601	EI-344436	IC TC9147P
3-IC602	EI-344437	IC TD6301AP
3-IC603	EI-344438	IC TD6104P
3-TR101	ET-709400	TR 2SK192A-Y
3-TR201	ET-702700	TR 2SC380TM O
3-TR202	ET-330225	TR 2SC1815 BL
3-TR203	ET-330225	TR 2SC1815 BL
3-TR204	ET-330225	TR 2SC1815 BL
3-TR205	ET-330225	TR 2SC1815 BL
3-TR206	ET-330225	TR 2SC1815 BL
3-TR207	ET-741903	TR 2SA1015-GR
3-TR208	ET-741903	TR 2SA1015-GR
3-TR209	ET-330225	TR 2SC1815 BL
3-TR210	ET-330225	TR 2SC1815 BL
3-TR211	ET-711433	TR 2SC2236Y
3-TR212	ET-741902	TR 2SC1815-BL
3-TR213	ET-702700	TR 2SC380TM O
3-TR601	ET-330225	TR 2SC1815 BL
3-TR602	ET-337604	TR FET 2SK246 Y
3-TR603	ET-330225	TR 2SC1815 BL
3-TR604	ET-330225	TR 2SC1815 BL
3-TR605	ET-308867	TR 2SA1015 O,Y,GR
3-TR606	ET-308867	TR 2SA1015 O,Y,GR
3-TR607	ET-702700	TR 2SC380TM O
3-TR608	ET-308867	TR 2SA1015 O,Y,GR
3-TR609	ET-308867	TR 2SA1015 O,Y,GR
3-TR610	ET-330225	TR 2SC1815 BL
3-D101	ED-709401	D VARACTOR KV1236Z2
3-D201	ED-702195	D SILICON 1S1555V-TP3
3-D202	ED-709441	D LED SG238W
3-D203	ED-327098	D ZENER H WZ-061
3-D206	ED-702195	D SILICON 1S1555V-TP3
3-D207	ED-702195	D SILICON 1S1555V-TP3
3-D208	ED-702195	D SILICON 1S1555V-TP3
3-D601	ED-702195	D SILICON 1S1555V-TP3
3-D602	ED-306724	D SILICON S5277B 100/1.0A
3-D603	ED-306724	D SILICON S5277B 100/1.0A
3-D604	ED-702195	D SILICON 1S1555V-TP3
3-D605	ED-702195	D SILICON 1S1555V-TP3
3-L102	EO-742246	COIL FM-CHOKE
3-L103	EO-741909	AF CHOKE COIL AC-3750

REF. NO.	PARTS NO.	DESCRIPTION
3-L104	EO-709404	COIL CHOKE 221
3-L105	EO-709405	COIL ANT MW
3-L106	EO-711435	COIL OSC MW
3-L201	EO-741909	AF CHOKE COIL AC-3750
3-LC201	EO-709409	COIL MPX
3-LC202	EO-709409	COIL MPX
3-IT201	BT-709406	TRANS IFT AM-M-CE
3-IT202	BT-709407	TRANS IFT FM-D
3-CF201	ER-709408	FILTER CE
3-CF202	ER-709408	FILTER CE
3-TC1	EC-749457	C S-FIX
3-VR201	EV-706603	R S-FIX 103
3-VR202	EV-703299	SEMI-FIXED/VOL. 500 OHMS
3-VR601	EV-703299	SEMI-FIXED/VOL. 500 OHMS
3-X1	EO-709414	OSC X'TAL
3-FL1	EM-709415	IND FL FIP7A8S
3-R101	ER-706608	R OMF 1W 331
3-R220	ER-706608	R OMF 1W 331
3-R230	ER-701107	R OMF 1W 151J
3-R259	ER-704152	△ R FUSE 1/4W 220J
3-R269	ER-704152	△ R FUSE 1/4W 220J
3-R601	ER-711438	R COMP 153 7P
3-R602	ER-711439	R COMP 183 7P
3-R603	ER-711440	R COMP 223 7P
3-R632	ER-306961	R OMF H SNP FS 2W 151J
3-2	EE-709403	FM TUNER

4. CONTROL P.C BOARD BLOCK

REF. NO.	PARTS NO.	DESCRIPTION
4-S1	ES-709418	SW KEY
4-S2	ES-709418	SW KEY
4-S3	ES-709418	SW KEY
4-S4	ES-709418	SW KEY
4-S5	ES-709418	SW KEY
4-S6	ES-709418	SW KEY
4-S7	ES-709418	SW KEY
4-S8	ES-709418	SW KEY
4-S10	ES-709418	SW KEY
4-S11	ES-709418	SW KEY
4-S12	ES-709418	SW KEY
4-S13	ES-709418	SE KEY
4-S14	ES-709418	SW KEY
4-S15	ES-709418	SW KEY
4-S16	ES-709418	SW KEY
4-S17	ES-709418	SE KEY
4-S18	ES-709418	SW KEY
4-S19	ES-709418	SW KEY
4-S20	ES-709418	SW KEY
4-S21	ES-709417	SW PUSH
4-S22	ES-709417	SW PUSH
4-S23	ES-709416	SW PUSH
4-D204	ED-703310	D LED LN417YP
4-D205	ED-703310	D LED LN417YP
4-D304	ED-701131	D LED LN-317GP
4-D451	ED-709421	D LED AA5527S-1
4-D452	ED-709421	D LED AA5527S-1
4-D453	ED-709421	D LED AA5527S-1
4-D454	ED-709421	D LED AA5527S-1
4-D606	ED-703243	D LED LN217RP
4-D607	ED-709421	D LED AA5527S-1
4-D608	ED-709421	D LED AA5527S-1
4-D609	ED-709421	D LED AA5527S-1
4-D610	ED-709421	D LED AA5527S-1
4-D611	ED-709421	D LED AA5527S-1
4-D612	ED-709421	D LED AA5527S-1
4-D613	ED-709421	D LED AA5527S-1
4-D614	ED-709421	D LED AA5527S-1
4-D704	ED-701131	D LED LN-317GP
4-D705	ED-701131	D LED LN-317GP
4-D706	ED-701131	D LED LN-317GP
4-D823	ED-701124	D LED LN328GP
4-D824	ED-709420	D LED LN29RP
4-D825	ED-709419	D LED LN410YP
4-R708	ER-749298	RS1M-120
4-R709	ER-329279	R OMF H FS 1W 271J

ASSEMBLY BLOCK

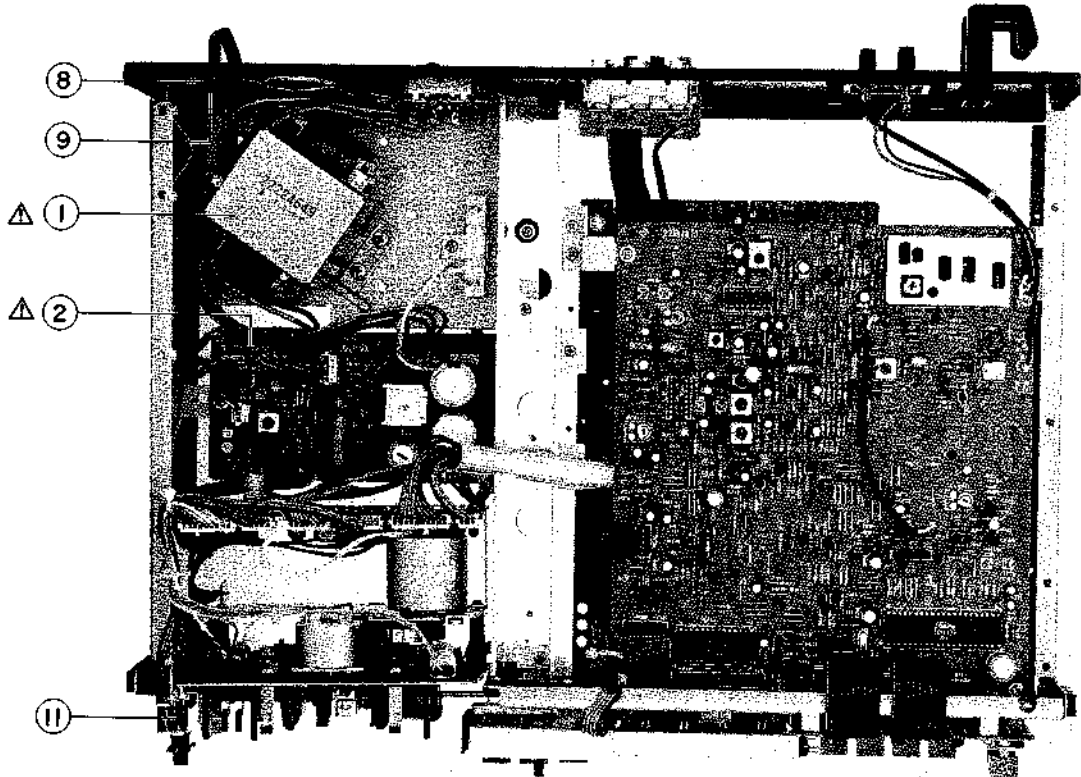
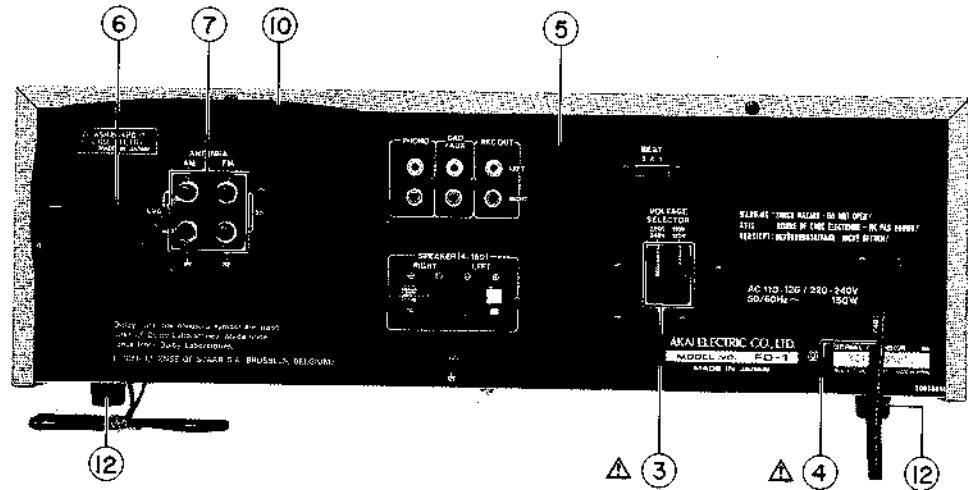

5. ASSEMBLY BLOCK

REF. NO.	PARTS NO.	DESCRIPTION	REF. NO.	PARTS NO.	DESCRIPTION
5-1U	BT-709396	△ TRANS POWER FD-1 (U)	5-5U	SP-711424	PANEL REAR FD-1 (U)
5-1C	BT-711442	△ TRANS POWER FD-1 (C,A)	5-5C	SP-711425	PANEL REAR FD-1 (C,A)
5-1E	BT-711443	△ TRANS POWER FD-1 (E)	5-5E	SP-711426	PANEL REAR FD-1 (E)
5-1S	BT-711444	△ TRANS POWER FD-1 (S,B)	5-5S	SP-711427	PANEL REAR FD-1 (S)
5-2U	EF-702200	△ FUSE 1S-T (U,E,S)	5-6	SZ-710453	HOLDER ANT
5-2C	EF-711445	△ FUSE 1.5A (C,A)	5-7	EJ-710451	TERMINAL SCREW 4P
5-3	ES-709398	△ SW SLIDE (U ONLY)	5-8	SZ-710448	HOLDER CODE
5-4U	EW-343363	△ AC CORD 2 CORES KP-8, SPT-2 UC (U,C,A)	5-9	SZ-710449	HOLDER CODE
5-4E	EW-313882	△ AC CORD 2 CORES KP-419C, LTCE-2F E (E)	5-10	EE-709445	ANT LOOP
5-4S	EW-201515	△ AC CORD 2 CORES KP-560, LTSA-2F S (S)	5-11	ES-709444	SW SLIDE (S24)
			5-12	SA-711361	RUBBER FOOT

FINAL ASSEMBLY BLOCK

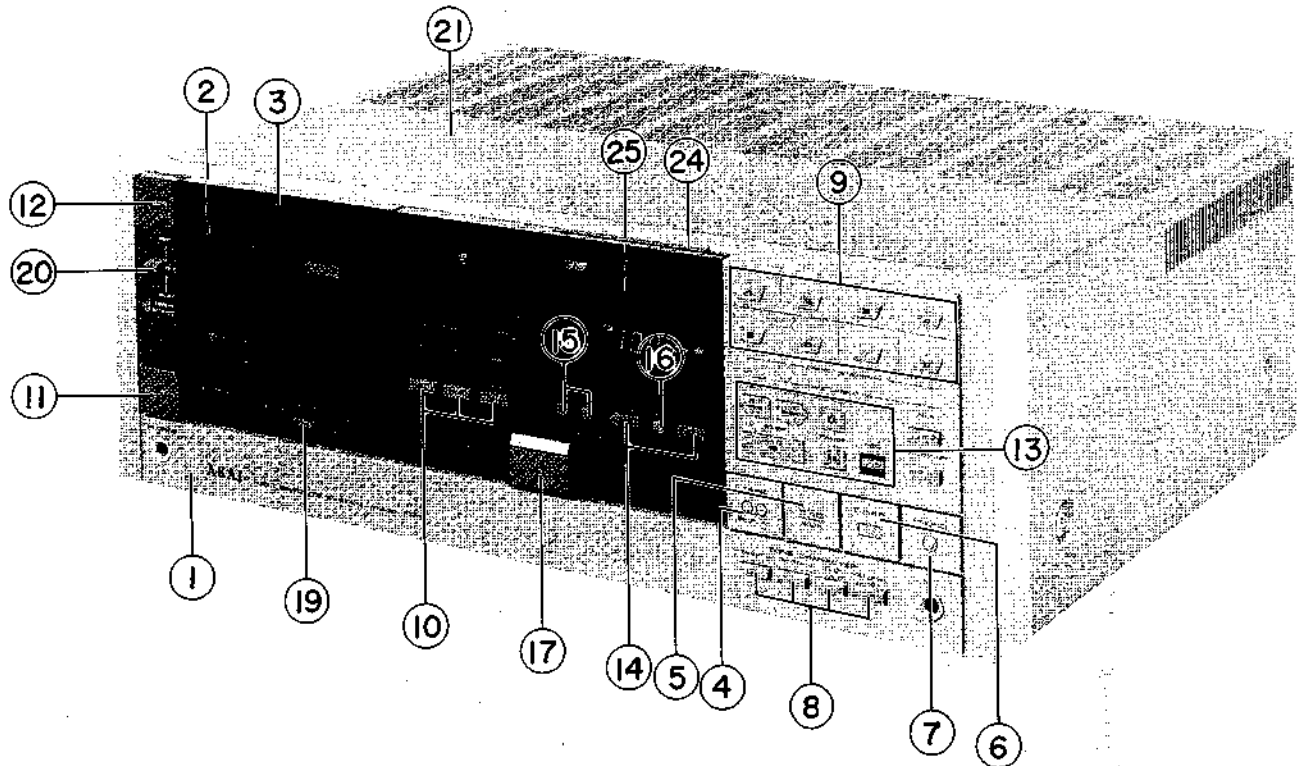

6. FINAL ASSEMBLY BLOCK

REF. NO.	PARTS NO.	DESCRIPTION	REF. NO.	PARTS NO.	DESCRIPTION
6-1	BD-749451	PANEL FRONT BLK FD-1	6-15	SB-711354	BUTTON B.M
6-2	TC-711341	HOLDER CASSETTE	6-16	SB-711355	BUTTON B.M
6-3	SP-711342	LID COVER CASSETTE	6-17	SK-711356	KNOB VOLUME ASSY
6-4	SB-711343	BUTTON MODE (TAPE)	6-18x	SK-711357	SHAFT VOLUME KNOB
6-5	SB-711344	BUTTON MODE (DAD)	6-19	SK-711358	KNOB BALANCE
6-6	SB-711345	BUTTON MODE (TUNER)	6-20	SK-711359	KNOB TIMER
6-7	SB-711346	BUTTON MODE (PHONO)	6-21	SP-711360	COVER UPPER
6-8	SB-711347	BUTTON SELECT	6-22x	MZ-711362	DUMPER (FOR CASSETTE HOLDER)
6-9	SB-711348	BUTTON PRESET ASSY	6-23x	ZG-711363	SP EJECT (FOR CASSETTE HOLDER)
6-10	SB-711349	BUTTON SELECT-T	6-24	SZ-711366	HOLDER CARD
6-11	SB-711350	BUTTON POWER	6-25	SZ-711367	FILTER LED
6-12	SB-711351	BUTTON EJECT	6-26x	TA-711371	SHEET STATION
6-13	SB-711352	BUTTON HOLDER ASSY	6-27x	TA-711372	STATION CARDS
6-14	SB-711353	BUTTON TUNE			

II. MODEL FP-3

MECHA AND FA CHASSIS BLOCK

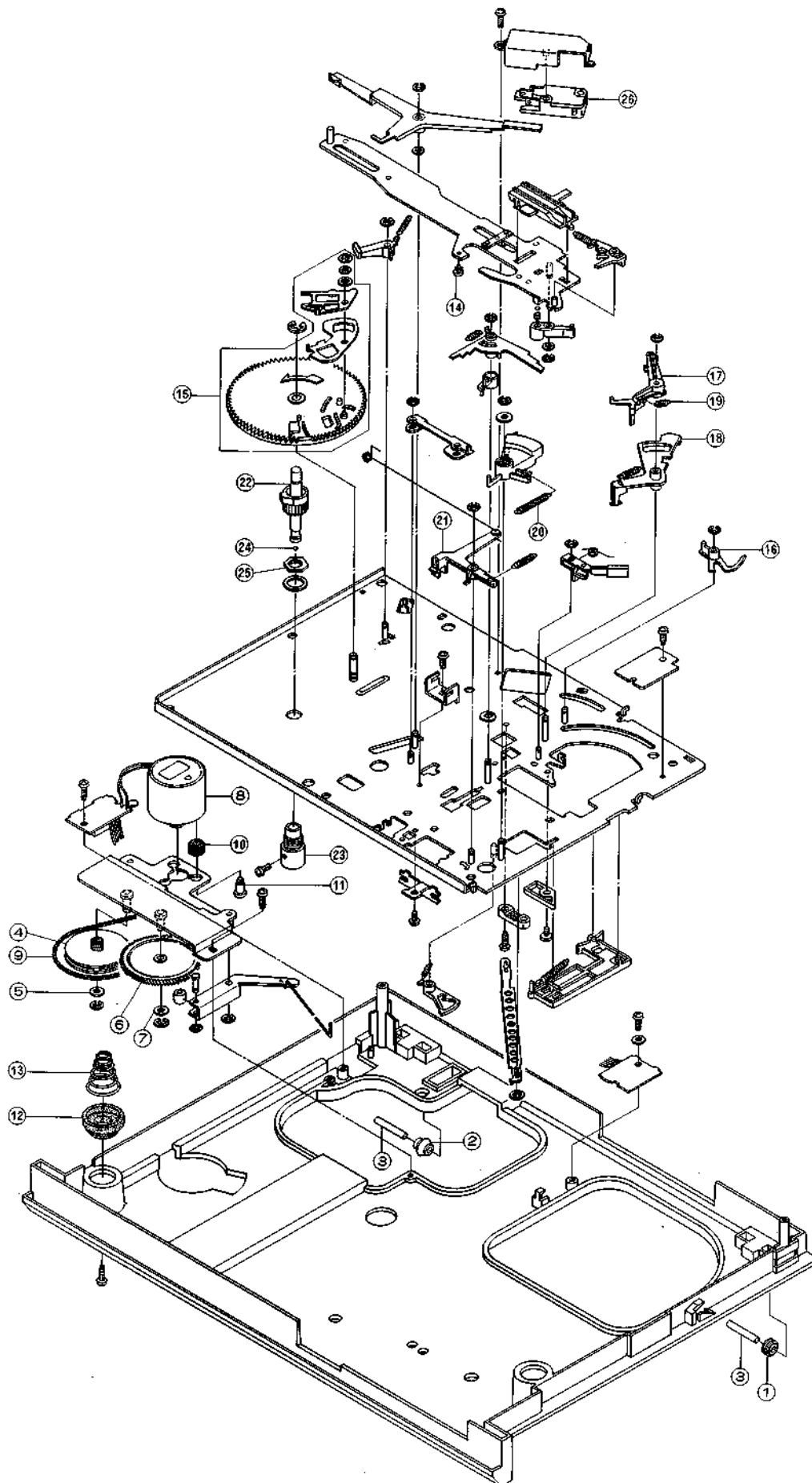

1. P.C BOARD BLOCK

REF. NO.	PARTS NO.	DESCRIPTION
1-1	ES-711327	SW PUSH 5THROW (SW1,2)
1-TR1	ET-701062	TR 2SD880 Y
1-D1	ED-308951	D ZENER WZ-120
1-D2	ED-306724	D SILICON S5277B 100/1.0A
1-VR1	EV-711331	R S-FIX 502
1-VR2	EV-711332	R S-FIX 103
1-D3	ED-711333	D LED GL-9PG34
1-D4	ED-711333	D LED GL-9PG34
1-SW3	ES-711334	SW SLIDE

2. MECHA AND FA CHASSIS BLOCK

REF. NO.	PARTS NO.	DESCRIPTION
2-1	MR-711295	ROLLER
2-2	MR-711299	ROLLER B
2-3	MS-711300	SHAFT ROLLER B
2-4	MR-711301	GEAR PULLEY
2-5	ZW-269954	PW31x070x025PSL
2-6	MZ-711302	GEAR DRIVE
2-7	ZW-259738	PW41x070x025PSL
2-8	BM-711303	MOTOR NG (W/PULLEY) PART
2-9	MB-711304	BELT
2-10	MB-711285	CUSHION RUBBER
2-11	ZS-711305	SCREW SPL
2-12	MB-711282	CUSHION RUBBER
2-13	ZG-711283	SP PUSH
2-14	ZW-302909	RV NYL30x035 BL
2-15	TP-711313	GEAR MAIN ASSY
2-16	ML-711314	LINK SW
2-17	ML-711315	ARM MICRO SW
2-18	ML-711316	LEVER MICRO SW
2-19	ZG-711317	SP PULL
2-20	ZG-711318	SP 035TN30.5
2-21	ML-711319	LEVER START
2-22	TP-711320	SHAFT TT ASS
2-23	MV-711321	BEARING TT SHAFT
2-24	MV-711322	STEEL BELL 1/8
2-25	ZW-711323	NUT M11-2T
2-26	ES-711335	SW MICRO (SW4)

ASSEMBLY BLOCK

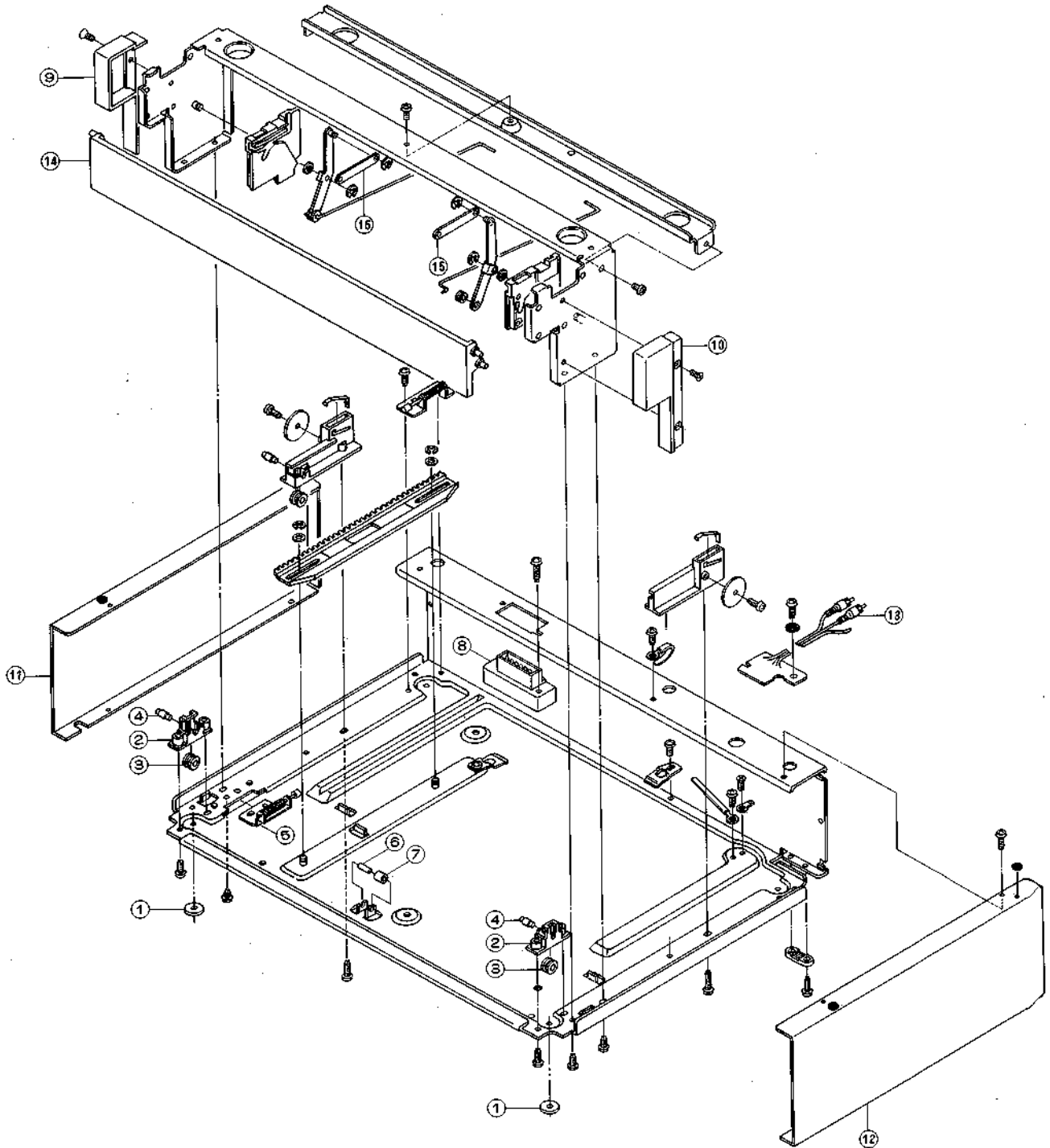

3. ASSEMBLY BLOCK

REF. NO.	PARTS NO.	DESCRIPTION
3-1	SA-711293	FOOT
3-2	MZ-711294	HOLDER ROLLER
3-3	MR-711295	ROLLER
3-4	MS-711296	SHAFT ROLLER
3-5	TP-711297	STOPPER SW F ASSY
3-6	MS-711296	SHAFT ROLLER
3-7	MR-711298	ROLLER C
3-8	EJ-346330	PLUG POWER M1673 6P

REF. NO.	PARTS NO.	DESCRIPTION
3-9	SD-711308	DECOLATION-L
3-10	SD-711309	DECOLATION-R
3-11	SP-711310	COVER (L)
3-12	SP-711311	COVER (R)
3-13	EW-711312	AUDIO CODE US1P
3-14	SP-711329	FRONT COVER
3-15	ML-711330	JOINT

CABINET BLOCK

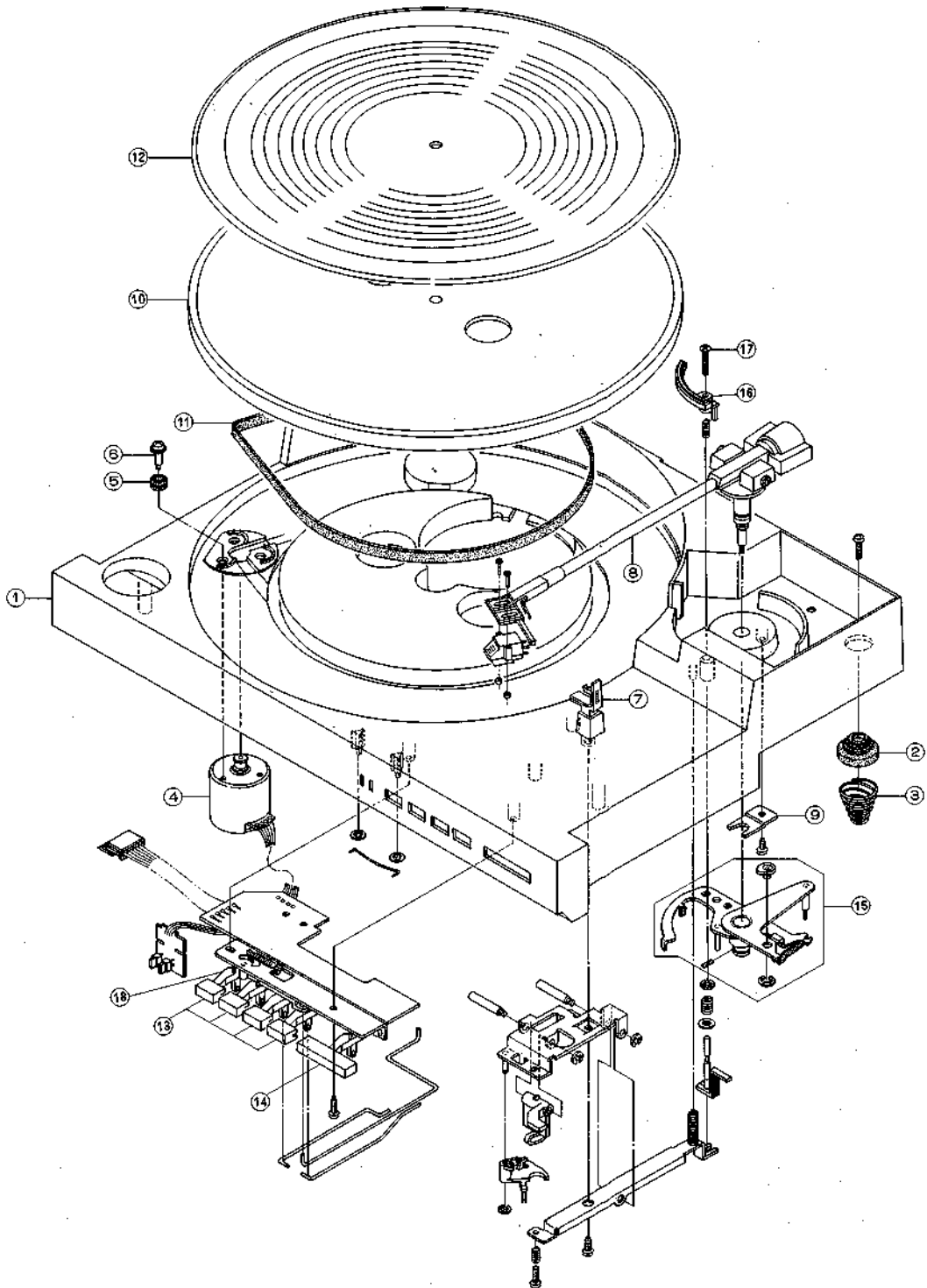

4. CABINET BLOCK

REF. NO.	PARTS NO.	DESCRIPTION
----------	-----------	-------------

4-1	BC-711281	CABINET
4-2	MB-711282	CUSHION RUBBER
4-3	ZG-711283	SP PUSH
4-4	BM-711284	MOTOR EG (W/PULLEY) PART
4-5	MB-711285	CUSHION RUBBER
4-6	ZS-711286	SCREW SPL
4-7	SD-711287	REST PU
4-8	TP-711288	ARM PU BLK
4-9	TP-711289	CLAMPER PU ARM
4-10	TP-711290	TURNTABLE

REF. NO.	PARTS NO.	DESCRIPTION
----------	-----------	-------------

4-11	MB-711291	BELT
4-12	TP-711292	TABLE SHEET UL
4-13	SK-711306	BUTTON SELECT
4-14	SK-711307	BUTTON
4-15	TP-711324	PU PLATE ASSY
4-16	TP-711325	BAR LIFT
4-17	ZS-711326	FLT20x12BLK
4-18	SZ-711328	JOINT BUTTON

INDEX

MODEL FD-1

PARTS NO.	REF. NO.	PARTS NO.	REF. NO.	PART NO.	REF. NO.	PARTS NO.	REF. NO.	PARTS NO.	REF. NO.
BA-711430	3-1U	ED-702195	3-D604	ER-331618	2-R553	ET-330225	2-TR481	MT-711375	1-4
BA-711431	3-1C	ED-702195	3-D605	ER-33085	2-R839	ET-330225	2-TR501	MT-711377	1-6
BA-749453	2-1U	ED-702236	2-D702	ER-333120	2-R007	ET-330225	2-TR703	MV-711382	1-12
BA-749454	2-1C	ED-702236	2-D703	ER-333120	2-R008	ET-330225	2-TR303	MV-711398	1-56
BA-749455	2-1S	ED-702236	2-D704	ER-336841	2-R013	ET-330225	2-TR304	MZ-711362	6-22X
BB-711481	1-1	ED-703243	4-D606	ER-658034	2-R854	ET-330225	2-TR801	MZ-711399	1-57
BD-749451	6-1	ED-703290	2-D001	ER-701107	3-R230	ET-330225	2-TR804	MZ-711406	1-68
BF-711395	1-52	ED-703310	4-D205	ER-704152	2-R710	ET-330225	2-TR311	MZ-711414	1-84
BL-711389	1-34	ED-703310	4-D204	ER-704152	3-R259	ET-330225	2-TR312	MZ-711416	1-86
BM-711391	1-45	ED-707776	2-D002	ER-704152	3-R269	ET-330225	2-TR817	SA-711361	5-12
BM-711410	1-76	ED-707934	2-D007	ER-704154	2-R511	ET-330225	3-TR202	SB-711343	6-4
BT-709396	5-1U	ED-709401	3-D101	ER-704154	2-R512	ET-330225	3-TR203	SB-711344	6-5
BT-709406	3-IT201	ED-709419	4-D825	ER-704791	2-R380	ET-330225	3-TR204	SB-711344	6-5
BT-709407	3-IT202	ED-709420	4-D824	ER-706608	3-R101	ET-330225	3-TR205	SB-711345	6-6
BT-711442	5-1C	ED-709421	4-D451	ER-706608	3-R220	ET-330225	3-TR206	SB-711346	6-7
BT-711443	5-1E	ED-709421	4-D452	ER-709408	3-CF201	ET-330225	3-TR209	SB-711347	6-8
BT-711444	5-1S	ED-709421	4-D453	ER-709408	3-CF202	ET-330225	3-TR210	SB-711348	6-9
EC-709431	2-CT701	ED-709421	4-D454	ER-709423	2-L301	ET-330225	3-TR601	SB-711349	6-10
EC-709431	2-CT702	ED-709421	4-D607	ER-709423	2-L302	ET-330225	3-TR603	SB-711350	6-11
EC-710377	2-C003	ED-709421	4-D608	ER-711438	3-R601	ET-330225	3-TR604	SB-711351	6-12
EC-710377	2-C004	ED-709421	4-D609	ER-711439	3-R602	ET-330225	3-TR610	SB-711352	6-13
EC-710378	2-C005	ED-709421	4-D610	ER-711440	3-R603	ET-336864	2-TR302	SB-711353	6-14
EC-749457	3-TC1	ED-709421	4-D611	ER-749298	4-R708	ET-336864	2-TR301	SB-711354	6-15
ED-306724	2-D820	ED-709421	4-D612	ER-749370	2-R001	ET-337604	3-TR602	SB-711355	6-16
ED-306724	2-D821	ED-709421	4-D613	ER-749371	2-R002	ET-337759	2-TR326	SK-711356	6-17
ED-306724	3-D602	ED-709421	4-D614	ER-749372	2-R010	ET-337759	2-TR325	SK-711357	6-18X
ED-306724	3-D603	ED-709426	2-D312	ER-749372	2-R011	ET-337759	2-TR306	SK-711358	6-19
ED-310578	2-D004	ED-709426	2-D313	ER-749373	2-R012	ET-337759	2-TR307	SK-711359	6-20
ED-310578	2-D005	ED-709441	2-D003	ES-709398	5-3	ET-337759	2-TR308	SP-711342	6-3
ED-322809	2-D822	ED-709441	3-D202	ES-709416	4-S23	ET-337759	2-TR310	SP-711360	6-21
ED-327098	3-D203	EE-709403	3-2	ES-709417	4-S21	ET-337759	2-TR309	SP-711424	5-5U
ED-539976	2-D006	EE-709445	5-10	ES-709417	4-S22	ET-337759	2-TR305	SP-711425	5-5C
ED-701124	4-D823	EF-702200	5-2U	ES-709418	4-S1	ET-338565	2-TR315	SP-711426	5-5E
ED-701131	4-D304	EF-711445	5-2C	ES-709418	4-S2	ET-338565	2-TR316	SP-711427	5-5S
ED-701131	4-D704	EI-213390	2-IC481	ES-709418	4-S3	ET-338565	2-TR323	SZ-710448	5-8
ED-701131	4-D705	EI-305456	2-IC802	ES-709418	4-S4	ET-338565	2-TR324	SZ-710449	5-9
ED-701131	4-D706	EI-344436	3-IC601	ES-709418	4-S5	ET-702700	3-TR201	SZ-710453	5-6
ED-702195	2-D803	EI-344437	3-IC602	ES-709418	4-S6	ET-702700	3-TR213	SZ-711366	6-24
ED-702195	2-D804	EI-344438	3-IC603	ES-709418	4-S7	ET-702700	3-TR607	SZ-711367	6-25
ED-702195	2-D805	EI-701061	3-IC202	ES-709418	4-S8	ET-703397	2-TR816	TA-711371	6-26X
ED-702195	2-D806	EI-702184	2-IC501	ES-709418	4-S10	ET-709400	3-TR101	TA-711372	6-27X
ED-702195	2-D807	EI-702184	2-IC502	ES-709418	4-S11	ET-709429	2-TR813	TC-711341	6-2
ED-702195	2-D808	EI-709247	2-IC303	ES-709418	4-S12	ET-709429	2-TR815	ZG-703359	1-11
ED-702195	2-D809	EI-709247	2-IC304	ES-709418	4-S13	ET-711433	3-TR211	ZG-711363	6-23X
ED-702195	2-D810	EI-709399	3-IC201	ES-709418	4-S14	ET-714902	3-TR212	ZG-711376	1-5
ED-702195	2-D811	EI-709422	2-IC301	ES-709418	4-S15	ET-741903	2-TR802	ZG-711384	1-14
ED-702195	2-D812	EI-709427	2-IC803	ES-709418	4-S16	ET-741903	2-TR803	ZG-711385	1-16
ED-702195	2-D813	EI-709428	2-IC801	ES-709418	4-S17	ET-741903	3-TR207	ZG-711390	1-35
ED-702195	2-D814	EI-709439	2-IC451	ES-709418	4-S18	ET-741903	3-TR208	ZG-711396	1-53
ED-702195	2-D815	EJ-702181	2-J4	ES-709418	4-S19	ET-741941	2-TR701	ZG-711401	1-60
ED-702195	2-D816	EJ-709432	2-J2	ES-709418	4-S20	ET-741953	2-TR001	ZG-711405	1-67
ED-702195	2-D817	EJ-709432	2-J3	ES-709433	2-S26	ET-741953	2-TR002	ZG-711411	1-80
ED-702195	2-D818	EJ-710451	5-7	ES-709438	2-S27	EV-703279	2-VR301	ZG-711412	1-81
ED-702195	2-D819	EJ-749374	2-J1	ES-709440	2-S28	EV-703279	2-VR302	ZS-709376	5-1U
ED-702195	2-D802	EM-709415	3-FL1	ES-709444	5-11	EV-703298	2-VR303	ZS-711378	1-7
ED-702195	2-D826	EO-702240	2-L306	ES-709453	2-S25	EV-703298	2-VR304	ZS-711379	1-8
ED-702195	2-D827	EO-702240	2-L305	ES-711419	1-S611	EV-703299	3-VR202	ZS-711394	1-51
ED-702195	2-D828	EO-709404	3-L104	ET-306720	2-TR702	EV-703299	3-VR601	ZW-711373	1-2
ED-702195	2-D829	EO-709405	3-L105	ET-308867	3-TR605	EV-706603	3-VR201	ZW-711388	1-33
ED-702195	2-D830	EO-709409	3-LC201	ET-308867	3-TR606	EV-709434	2-VR452	ZW-711393	1-50
ED-702195	2-D301	EO-709409	3-L202	ET-308867	3-TR608	EV-709436	2-VR451	ZW-711397	1-54
ED-702195	2-D302	EO-709414	3-X1	ET-308867	3-TR609	EW-201515	5-4S	ZW-711402	1-61
ED-702195	2-D303	EO-709425	2-L303	ET-325482	2-TR808	EW-313882	5-4E		
ED-702195	2-D305	EO-709425	2-L304	ET-325482	2-TR809	EW-343363	5-4U		
ED-702195	2-D306	EO-709430	2-L701	ET-325482	2-TR810	HA-711383	1-13		
ED-702195	2-D307	EO-711435	3-L106	ET-325482	2-TR811	HE-711380	1-9		
ED-702195	2-D308	EO-741909	3-L103	ET-325482	2-TR812	HP-711381	1-10		
ED-702195	2-D309	EO-741909	3-L201	ET-325482	2-TR807	MB-709443	1-30		
ED-702195	2-D310	EO-742246	3-L102	ET-325482	2-TR814	MB-711392	1-47		
ED-702195	2-D311	EP-711418	1-L602	ET-328861	2-TR805	MB-711409	1-74		
ED-702195	2-D455	EP-711418	1-L601	ET-328861	2-TR806	MB-711413	1-83		
ED-702195	2-D456	ER-305722	2-R006	ET-330225	2-TR313	MC-709442	1-89X		
ED-702195	2-D481	ER-306961	2-R513	ET-330225	2-TR314	ML-711386	1-17		
ED-702195	2-D482	ER-306961	2-R514	ET-330225	2-TR317	ML-711400	1-58		
ED-702195	2-D801	ER-306961	3-R632	ET-330225	2-TR318	ML-711403	1-64		
ED-702195	3-D201	ER-321192	2-R857	ET-330225	2-TR319	ML-711404	1-66		
ED-702195	3-D206	ER-324670	2-R003	ET-330225	2-TR320	ML-711407	1-70		
ED-702195	3-D207	ER-324670	2-R005	ET-330225	2-TR322	ML-711415	1-85		
ED-702195	3-D601	ER-329070	2-R849	ET-330225	2-TR321	ML-711417	1-87		
ED-702195	3-D208	ER-329279	4-R709	ET-330225	2-TR327	MT-711374	1-3		

INDEX

MODEL FP-3

PARTS NO.	REF. NO.	PARTS NO.	REF. NO.	PARTS NO.	REF. NO.	PARTS NO.	REF. NO.	PARTS NO.	REF. NO.
BC-711281	4-1								
BM-711284	4-4								
BM-711303	2-8								
ED-306724	1-D2								
ED-308951	1-D1								
ED-711333	1-D4								
ED-711333	1-D3								
EJ-346330	3-8								
ES-711327	1-1								
ES-711334	1-SW3								
ES-711335	2-26								
ET-701062	1-TR1								
EV-711331	1-VR1								
EV-711332	1-VR2								
EW-711312	3-13								
MB-711282	2-12								
MB-711282	4-2								
MB-711285	2-10								
MB-711285	4-5								
MB-711291	4-11								
MB-711304	2-9								
ML-711314	2-16								
ML-711315	2-17								
ML-711316	2-18								
ML-711319	2-21								
ML-711330	3-15								
MR-711295	2-1								
MR-711295	3-3								
MR-711298	3-7								
MR-711299	2-2								
MR-711301	2-4								
MS-711296	3-4								
MS-711296	3-6								
MS-711300	2-3								
MV-711321	2-23								
MV-711322	2-24								
MZ-711294	3-2								
MZ-711302	2-6								
SA-711293	3-1								
SD-711287	4-7								
SD-711308	3-9								
SD-711309	3-10								
SK-711306	4-13								
SK-711307	4-14								
SP-711310	3-11								
SP-711311	3-12								
SP-711329	3-14								
SZ-711328	4-18								
TP-711288	4-8								
TP-711289	4-9								
TP-711290	4-10								
TP-711292	4-12								
TP-711297	3-5								
TP-711313	2-15								
TP-711320	2-22								
TP-711324	4-15								
TP-711325	4-16								
ZG-711283	2-13								
ZG-711283	4-3								
ZG-711317	2-19								
ZG-711318	2-20								
ZS-711286	4-6								
ZS-711305	2-11								
ZS-711326	4-17								
ZW-259738	2-7								
ZW-269954	2-5								
ZW-302909	2-14								
ZW-711323	2-25								

TC4049BP

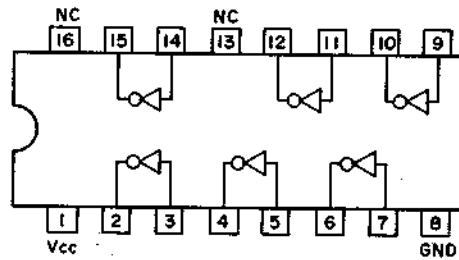

- 1. SC
- 2. FD
- 3. FD
- 4. FP

TC9147P

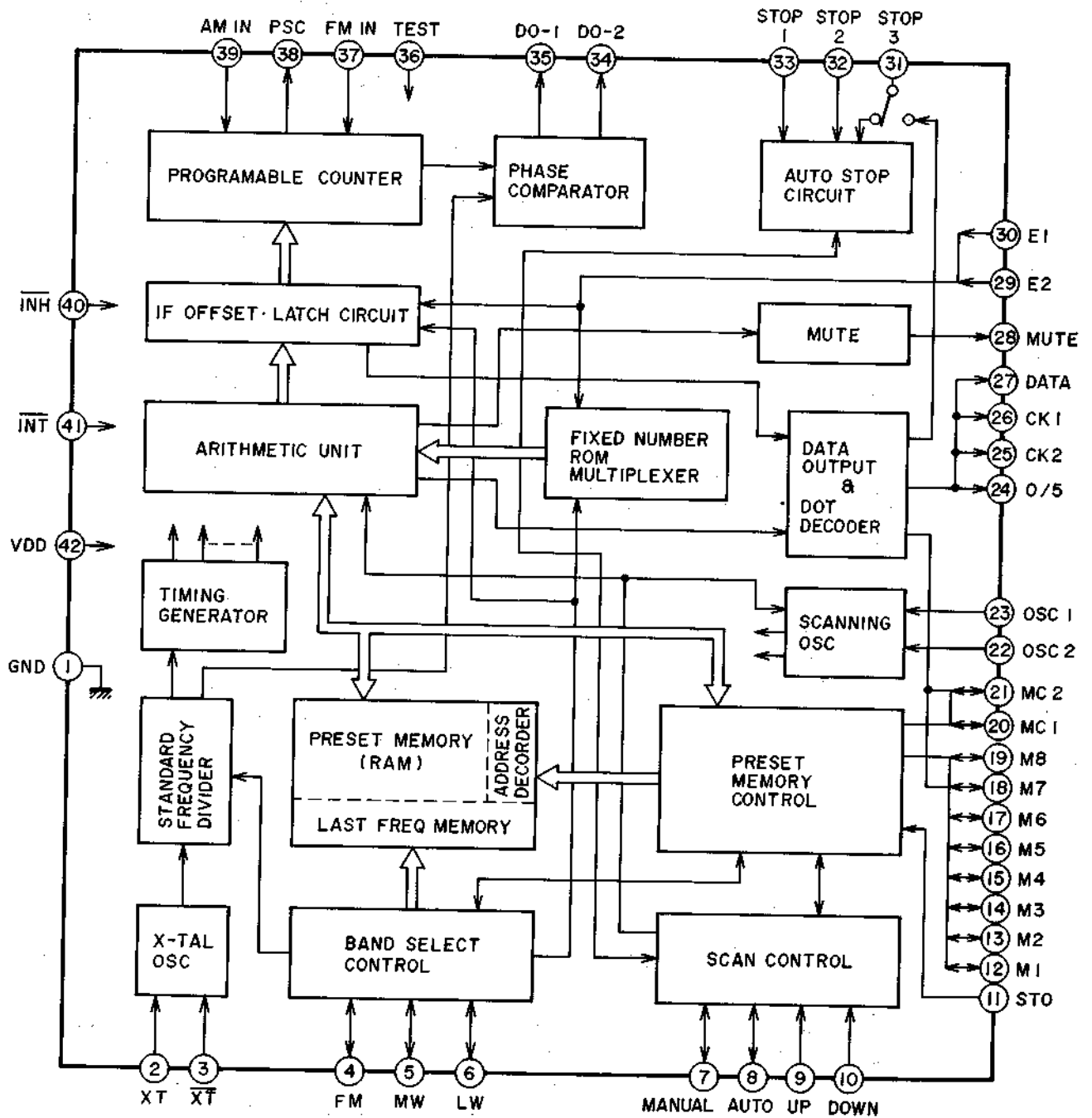

TERMINAL DESCRIPTION OF IC (TC9147P)

Pin No.	Symbol	Meaning	Function
1	GND	Ground	
2	XT	X-TAL OSC Terminals	Input Terminal of Standard Frequency OSC (X-TAL: 7.2MHz)
3	XT		
4	FM	FM Band Designation Input	Band Selector ACTIVE "High"
5	MW	MW Band Designation Input	
6	LW	LW Band Designation Input	
7	Manual	Manual Tuning Mode	Manual/Auto Tuning Selector
8	Auto	Auto Tuning Mode	
9	UP	UP Operation Key Input	UP/DOWN Tuning Selector
10	Down	Down Operation Key Input	
11	STO	Memory Store Command Input	Memory at preset memory operation
12 19	M1 M8	Preset Memory Channel Designation Inputs	Random Access for 16-Preset-Memory with the inputs of MC1/MC2
20	MC1	Memory Control Input	⑧ Stations (FM/AM)/⑩ Stations (FM + MW + LW) Preset Memory Selector
21	MC2		
22	OSC2	AM OSC Terminal	CR Connector Terminal for AM Search Scan Speed
23	OSC1	FM OSC Terminal	CR Connection Terminal for FM Search Scan Speed
24	0/5	FM 50kHz Output	Level "H" Output for 50kHz Step (S. Africa and Europe area)
25	CK2	Receiving Frequency Data Serial Output	Supply Serial Data & Timing Clock to TD6301AP (Receiving Frequency Digital Display Driver)
26	CK1		
27	Data		
28	Mute	Muting Signal Output	Level "H" Output when Muting
29	E2	Area Designation Input	Area Selector (Japan, US, Europe, S. Africa)
30	E1		
31	Stop 3	AM IF Signal Input	Stops Auto Search at AM IF (450kHz)
32	Stop 2	Auto Search Stop Signal Input	Stops Auto Search at Level "H" while level "H" at Stop 1
33	Stop 1	Scan Speed Slow-Down Input	1/2 Speed-Down of Auto Search at Level "H"
34	DO-2	Phase Comparator Output	Phase Comparator Output
35	DO-1		
36	Test	Test Terminal	Test Mode at Level "H"
37	FM in	FM Programmable Counter Input	Connected to Prescaler (TD6104P) Output
38	PSC	Prescaler Control Output	Count-Down (1/30, 1/32) Designation Output for Prescaler
39	AM in	AM Programmable Counter Input	AM Local OSC Signal Input
40	$\overline{\text{INH}}$	Inhibit Input	Normal at Level "H" Inhibit at Level "L"
41	$\overline{\text{INT}}$	Initialize Input	Normal at Level "H" Initialize at Level "L"
42	VDD	Power Terminal	+5V is supplied

TC9143P

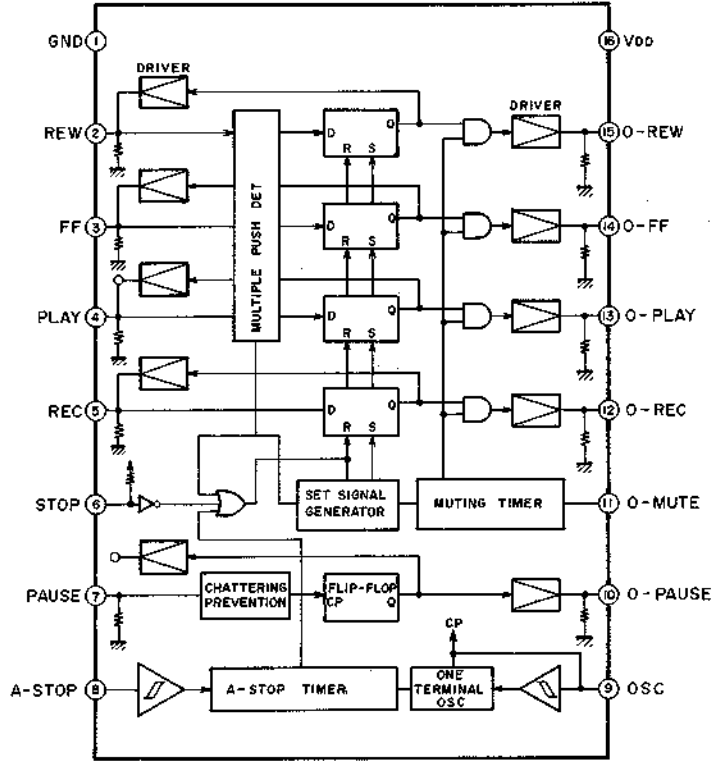

TD6104P

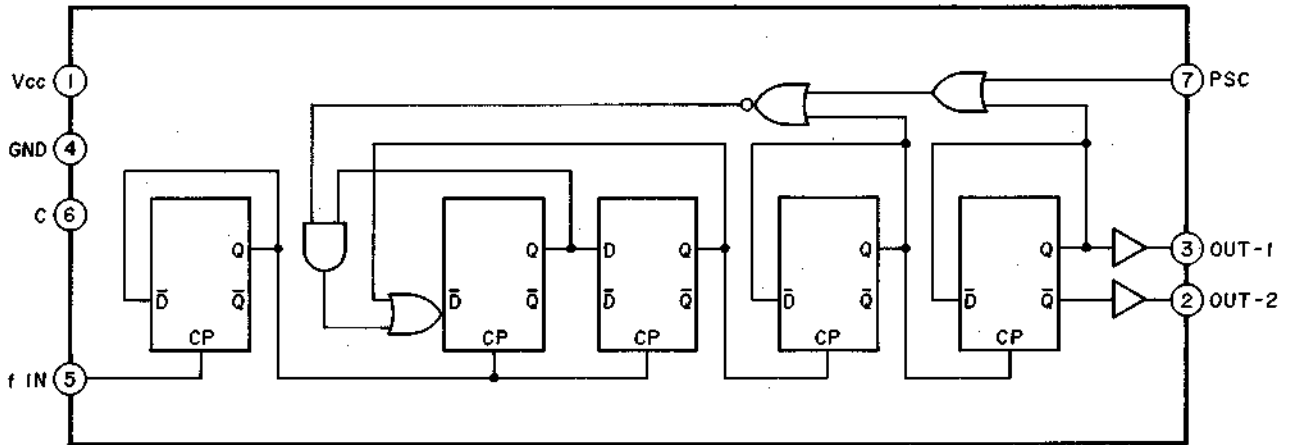

TERMINAL DESCRIPTION OF IC (TD6104P)

Pin No.	Symbol	Description
5	Fin	FM Local OSC Input
3	OUT-1	Count-Down Frequency Output ($f_{in}/30$ or $f_{in}/32$)
2	OUT-2	Inverted Output of OUT-1
7	PCS	Count-Down-Ratio Switch Signal Input $1/32$ at $V_{psc} \geq 2V$ $1/30$ at $V_{psc} \leq 1V$
6	C	Bypass condenser terminal for bias circuit
1	Vcc	+5V
4	GND	Ground

TD6301AP

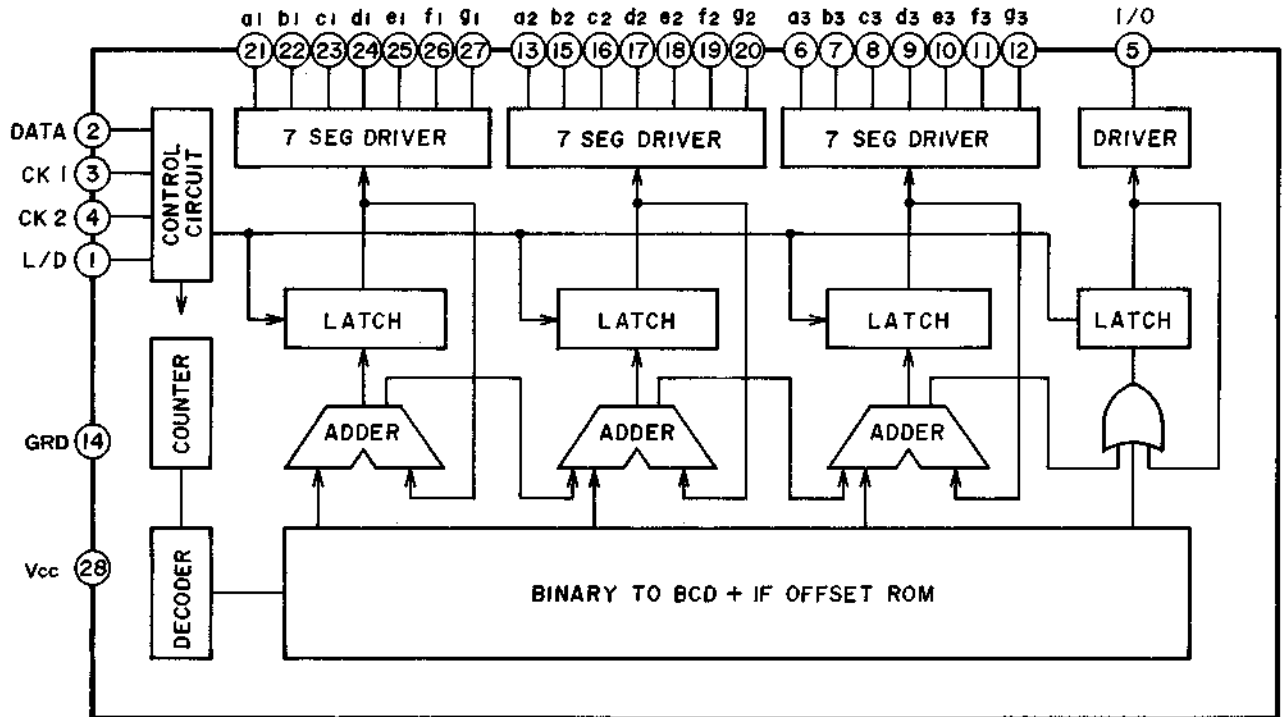

TERMINAL DESCRIPTION OF IC (TD6301AP)

Pin No.	Symbol	Description
1	L/D	Output Select Signal Input Terminal (To Change the Output for various Display such as LED, FL & LCD)
2	Data	Receiving Frequency Data Input Terminal (Serial Input from System Controller LSI)
3	CK1	Control Timing Input Terminal for Receiving Frequency Data Input (Simultaneously W/Data from System Controller LSI)
4	CK2	
5	I/O	Segment Driver Output Terminal for: FM: 100 ^S MHz AM: 1000 ^S kHz
6 ? 12	a3 ? g3	7 Segment Driver Output Terminals for: FM: 10 ^S MHz AM: 100 ^S kHz
13 ? 20	a2 ? g2	7 Segment Driver Output Terminals for: FM: 1 ^S MHz AM: 10 ^S kHz
21 ? 27	a1 ? g1	7 Segment Driver Output Terminals for: FM: 100 ^S kHz AM: 1 ^S kHz
14	Vcc	-16.8V
28	GND	-16.8V

TLO72DE

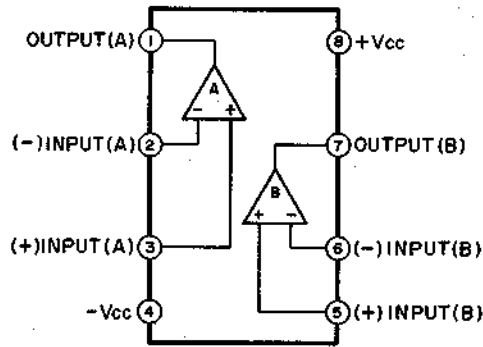

μ PC1188H

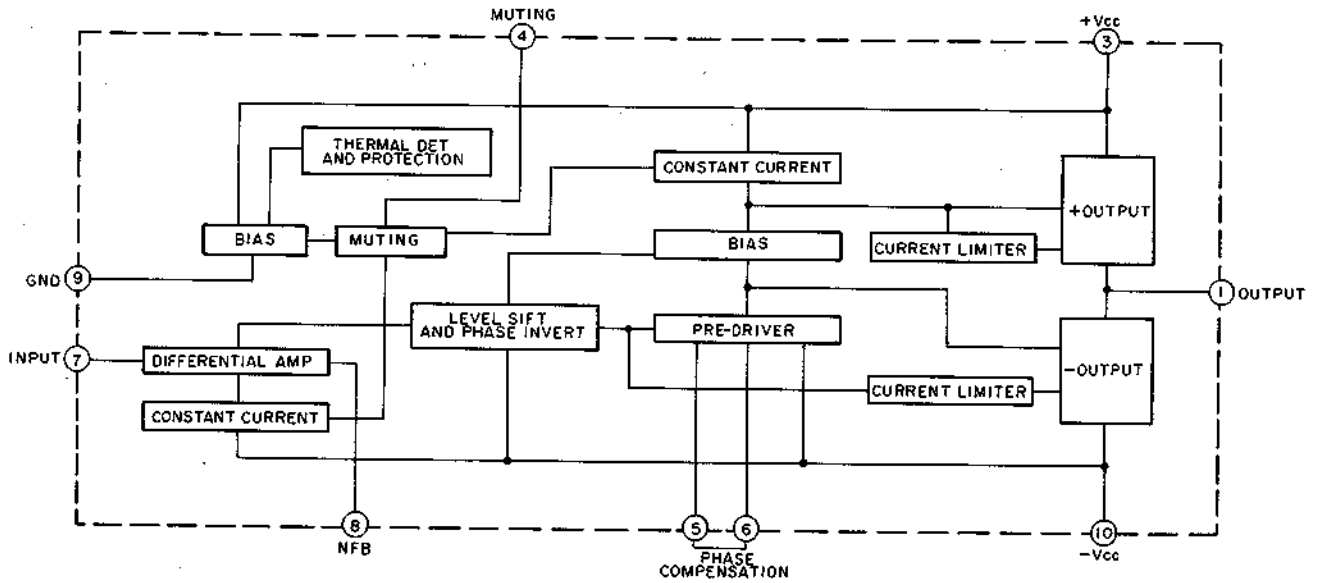

μ PC1197C

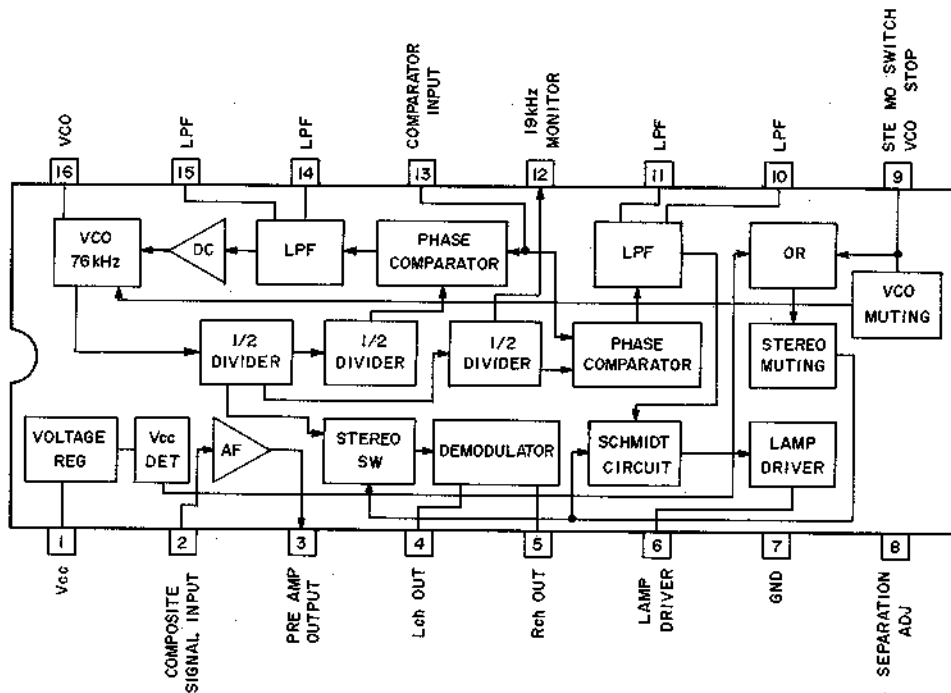

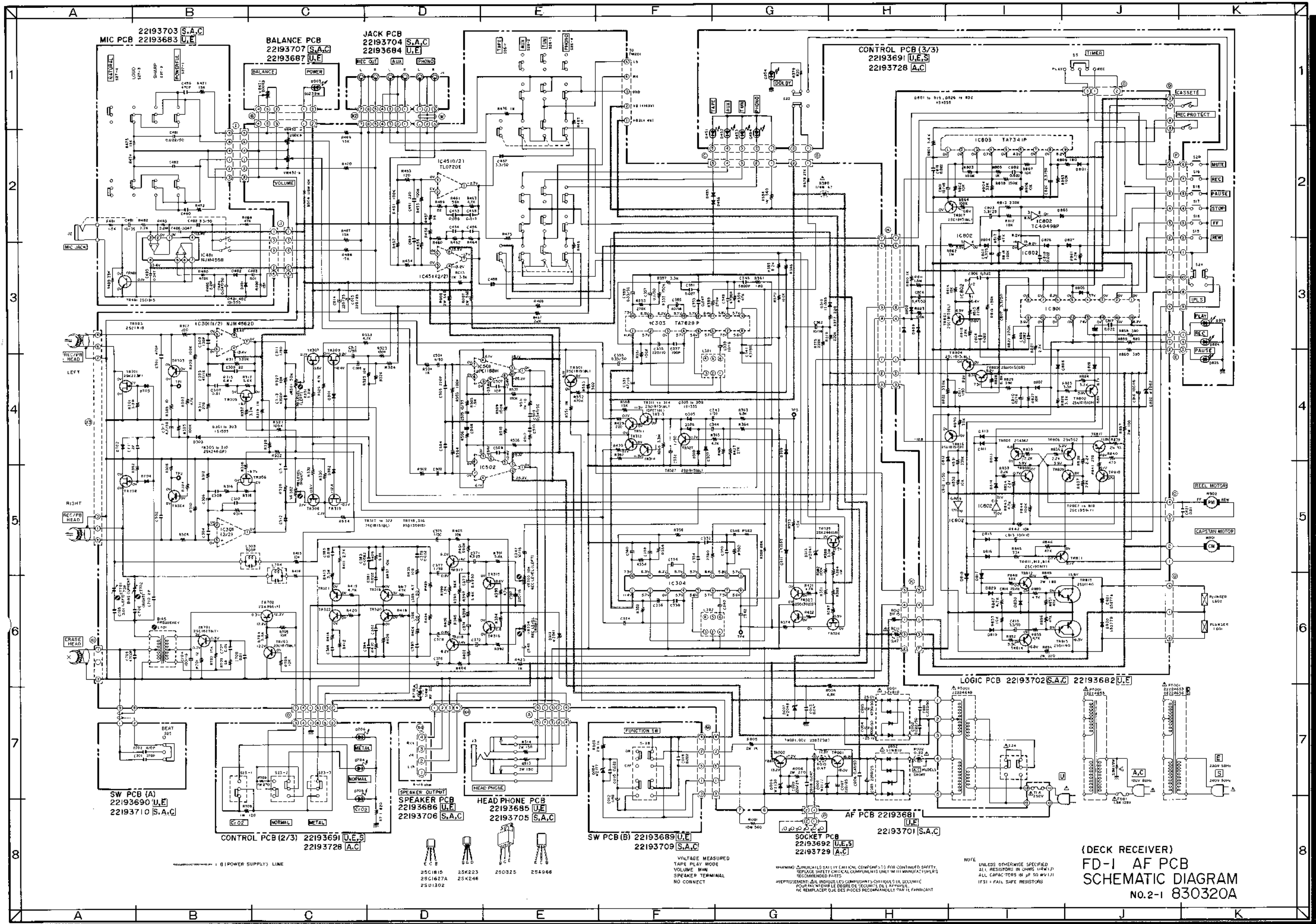

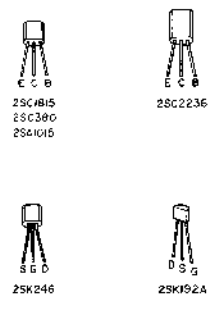
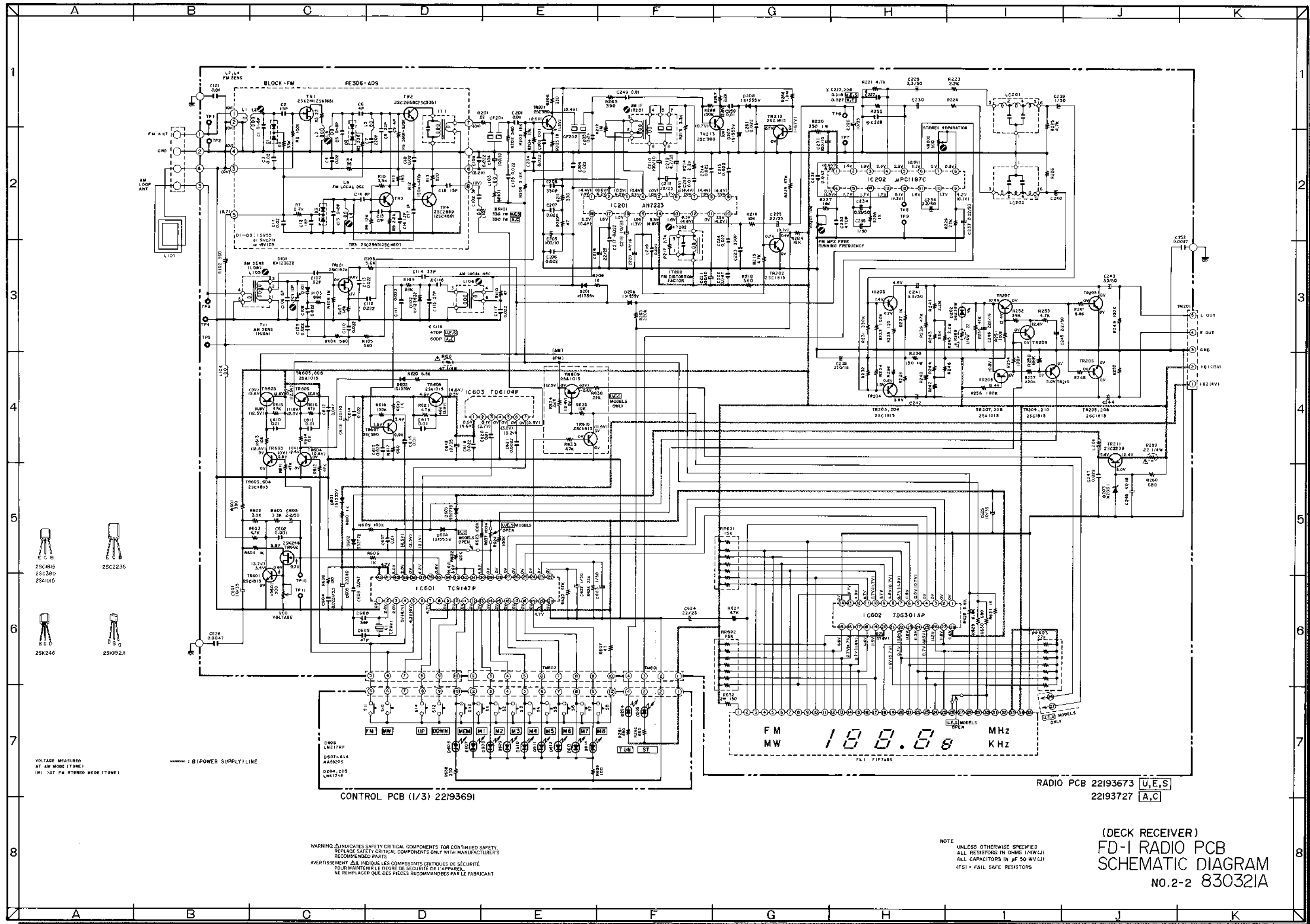

VOLTAGE MEASURED AT 4M MODE (TUNE) IN 1ST FM STEREO MODE (TUNE)

WARNING: Δ INDICATES SAFETY CRITICAL COMPONENTS FOR CONTINUED SAFETY. REPLACE SAFETY CRITICAL COMPONENTS ONLY WITH MANUFACTURER'S RECOMMENDED PARTS.
 AVERTISSEMENT: Δ IL INDIQUE LES COMPOSANTS CRITIQUES DE SÉCURITÉ POUR MAINTENIR LE DEGRÉ DE SÉCURITÉ DE L'APPAREIL. NE REMPLACER QUE DES PIÈCES RECOMMANDÉES PAR LE FABRICANT.

NOTE
 UNLESS OTHERWISE SPECIFIED ALL RESISTORS IN OHMS (1/4W/1%) ALL CAPACITORS IN μF (50 WV/1%) (FS) = FAIL SAFE RESISTORS

(DECK RECEIVER)
 FD-1 RADIO PCB
 SCHEMATIC DIAGRAM
 No.2-2 830321A

FP-3

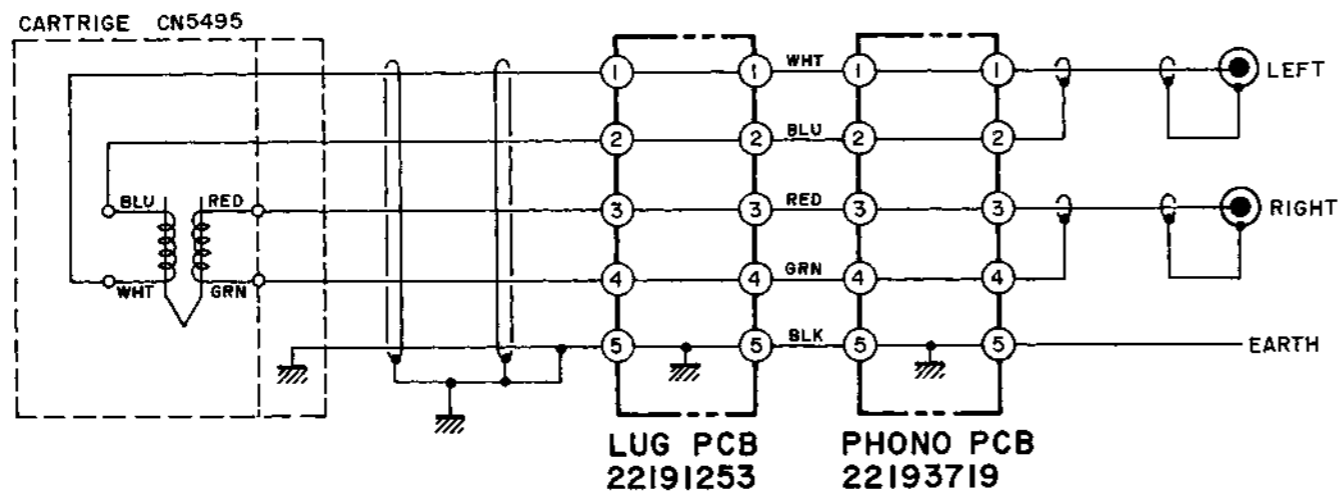
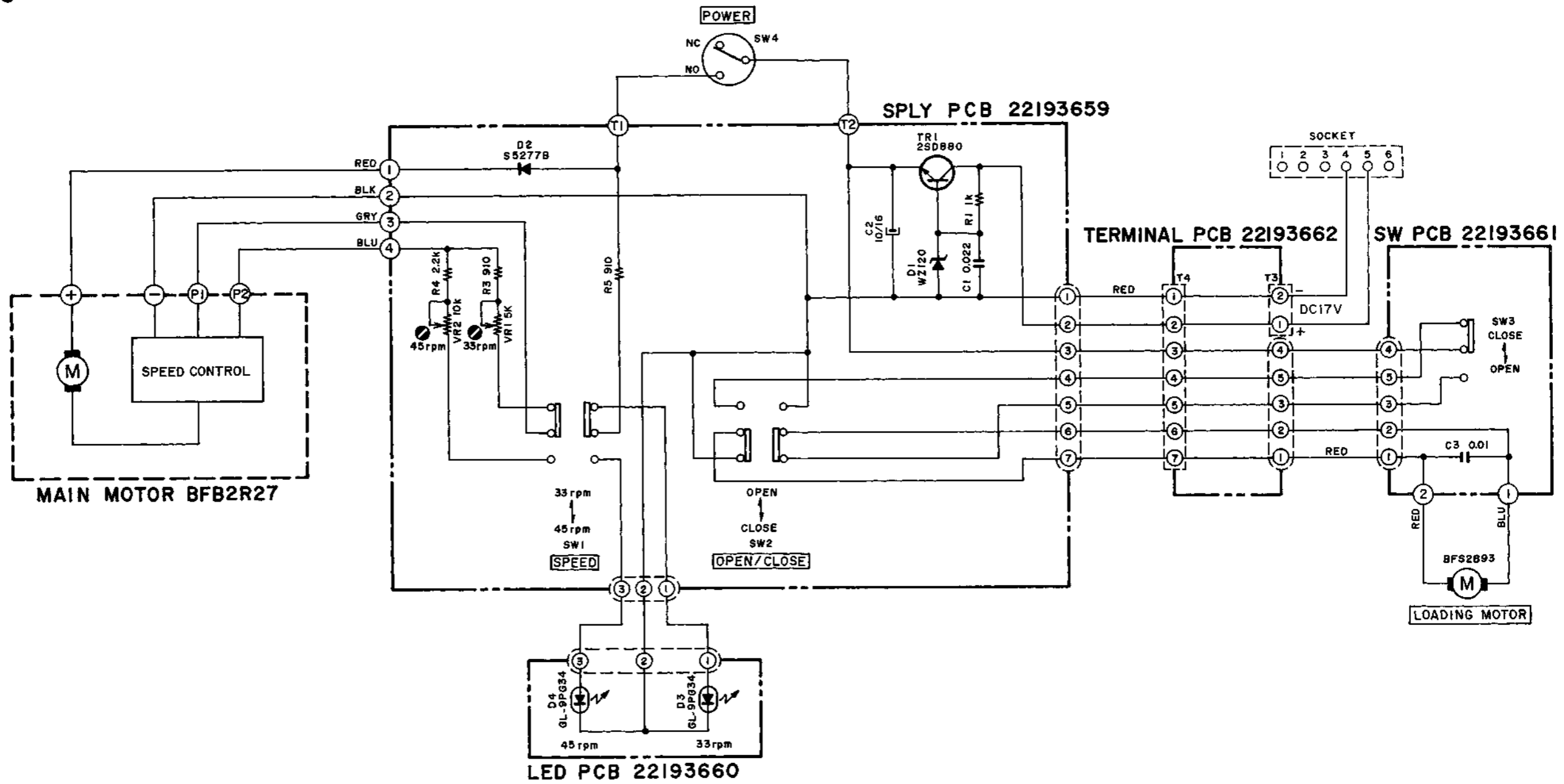

NOTE
UNLESS OTHERWISE SPECIFIED
ALL RESISTORS IN OHMS 1/4W(J)
ALL CAPACITORS IN μ F 50 WV(J)

(TURNTABLE)
FP-3
SCHEMATIC DIAGRAM
No. 830322A