

# AKAI SERVICE MANUAL

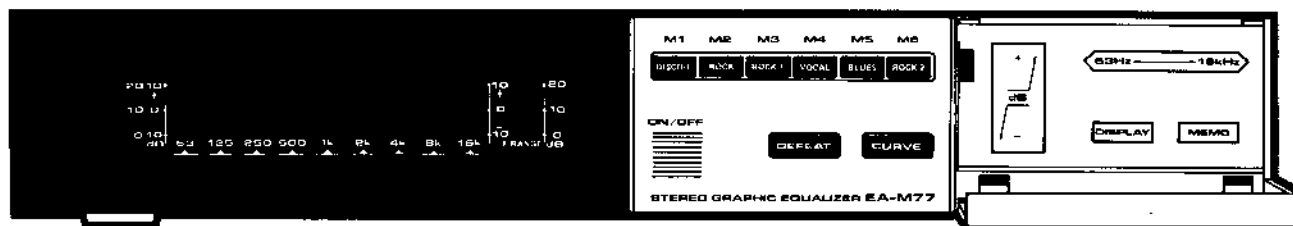

STEREO GRAPHIC EQUALIZER

MODEL **EA-M77**

## ABBREVIATIONS FOR SERVICE MANUAL MODEL EA-M77

ABBREVIATION	EXPLANATION
AC	Alternating Current
BPF	Band Pass Filter
CPU	Central Processing Unit
EVR	Electronic Variable Resistor
F.F	Flip Flop
FLD	FLuorescent Display
FREQ	FREQuency
GEQ	Graphic EQualizer
SW	SWitch

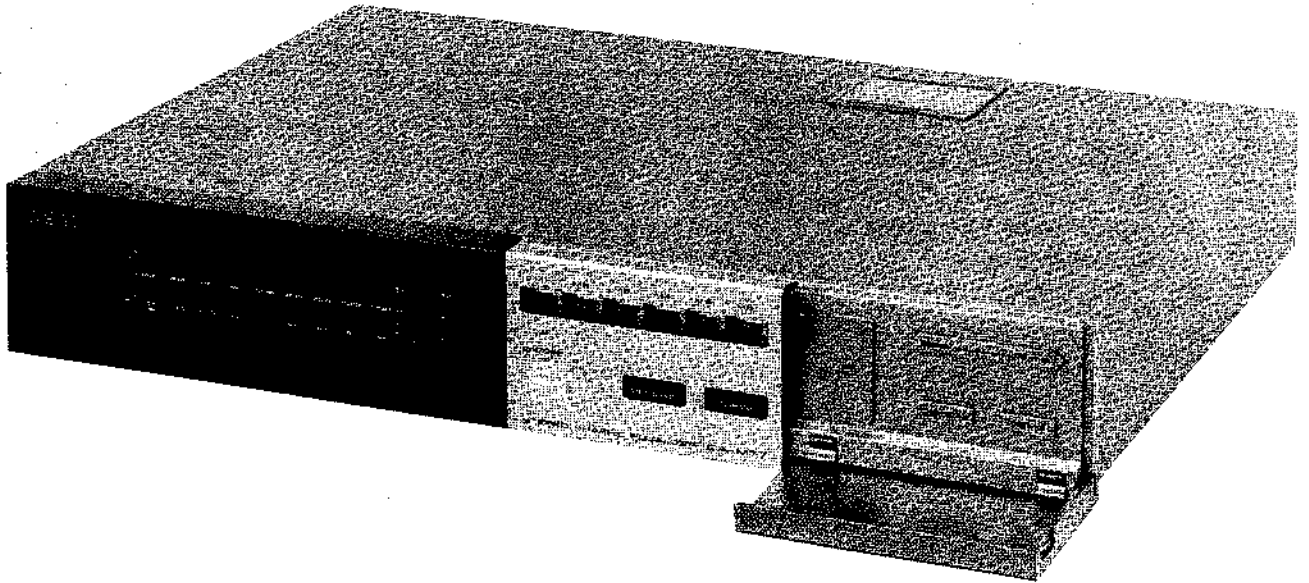

**STEREO GRAPHIC EQUALIZER**

**MODEL EA-M77**

**SECTION 1 SERVICE MANUAL ..... 3**  
**SECTION 2 PARTS LIST ..... 7**

# SAFETY INSTRUCTIONS

## SAFETY CHECK AFTER SERVICING

Confirm the specified insulation resistance between power cord plug prongs and externally exposed parts of the set is greater than 10 Mohms, but for equipment with external antenna terminals (tuner, receiver, etc.) and is intended for **C** or **A**, specified insulation resistance should be more than 2.2 Mohms (ground terminals, microphone jacks, headphone jacks, line-in-out jacks etc.)

## PRECAUTIONS DURING SERVICING

1. Parts identified by the **Δ** symbol parts are critical for safety.  
Replace only with parts number specified.
2. In addition to safety, other parts and assemblies are specified for conformance with such regulations as those applying to spurious radiation. These must also be replaced only with specified replacements.  
Examples: RF converters, tuner units, antenna selector switches, RF cables, noise blocking capacitors, noise blocking filters, etc.
3. Use specified internal wiring. Note especially:
  - 1) Wires covered with PVC tubing
  - 2) Double insulated wires
  - 3) High voltage leads
4. Use specified insulating materials for hazardous live parts. Note especially:
  - 1) Insulation Tape
  - 2) PVC tubing
  - 3) Spacers (Insulating Barriers)
  - 4) Insulation sheets for transistors
  - 5) Plastic screws for fixing microswitch (especially in turntable)
5. When replacing AC primary side components (transformers, power cords, noise blocking capacitors, etc.), wrap ends of wires securely about the terminals before soldering.

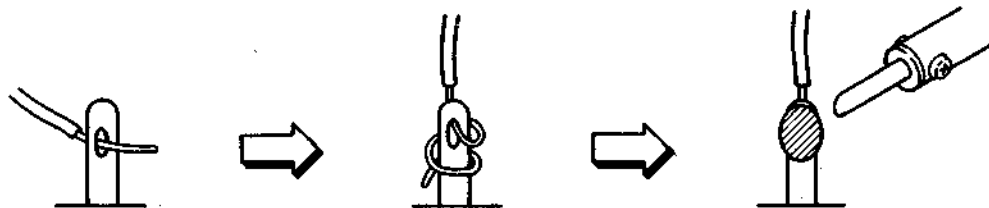

6. Observe that wires do not contact heat producing parts (heatsinks, oxide metal film resistors, fusible resistors, etc.).
7. Check that replaced wires do not contact sharp edged or pointed parts.
8. Also check areas surrounding repaired locations.
9. Use care that foreign objects (screws, solder droplets, etc.) do not remain inside the set.

## VOLTAGE CONVERSION

Each machine is preset at the factory according to its destination, but some machines can be set to 110V, 120V, 220V, or 240V as required.

If your machine's voltage can be converted:

Before connecting the power cord, turn the **VOLTAGE SELECTOR** located on the rear panel with a screwdriver until the correct voltage is indicated. Models for Japan, USA, Canada, Europe, UK and Australia are not equipped with this facility.

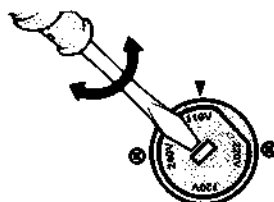

---

SECTION 1

**SERVICE MANUAL**

TABLE OF CONTENTS

I. SPECIFICATIONS ..... 4  
II. DISMANTRING OF UNIT ..... 4  
III. CONTROLS ..... 5  
IV. PRINCIPAL PARTS LOCATION ..... 6  
V. P.C BOARD TITLES AND IDENTIFICATION NUMBERS ..... 6

For basic adjustments, measuring methods, and operating principles, refer to GENERAL TECHNICAL MANUAL.

# I. SPECIFICATIONS

CENTER FREQUENCIES	63Hz/125Hz/250Hz/500Hz/1kHz/2kHz/4kHz/8kHz/16kHz
CONTROL RANGE	±10dB
INPUT SENSITIVITY/IMP. (LINE IN)	410mV/47kohms
S/N (IHF-A)	90dB
CHANNEL SEPARATION	65dB (1kHz)
DISTORTION	0.015% (20Hz to 20kHz)
POWER REQUIREMENTS	100V, 50/60Hz for Japan 120V, 60Hz for USA and Canada 220V, 50Hz for Europe except UK 240V, 50Hz for UK and Australia 110V/120V/220V/240V, 50/60Hz switchable for other countries
POWER CONSUMPTION	J.A.C : 10W U : 13W E.V.B.S.: 12W
DIMENSIONS	350 (W) × 59 (H) × 255 (D) mm (13.8 × 2.1 × 10.0 inches)
WEIGHT	3.1kg (6.8lbs)

\* For improvement purposes, specifications and design are subject to change without notice.

# II. DISMANTLING OF UNIT

In case of trouble, etc. necessitating dismantling, please dismantle in the order shown in the photographs. Reassemble in reverse order.

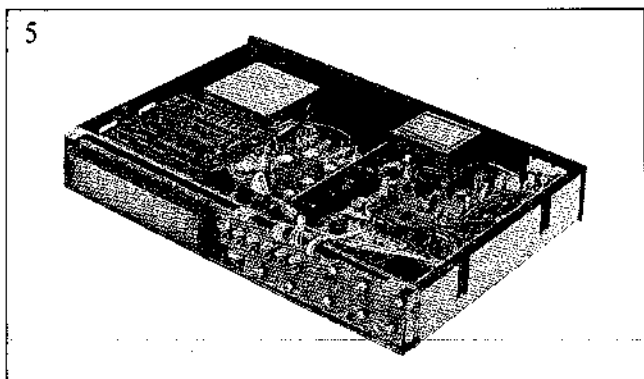
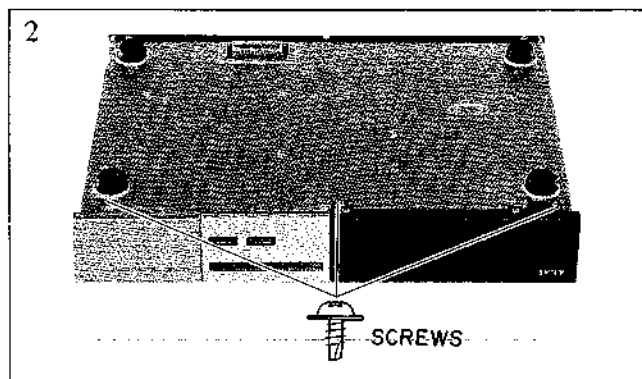
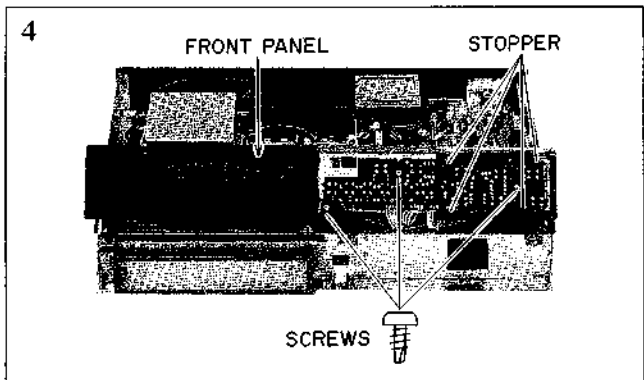
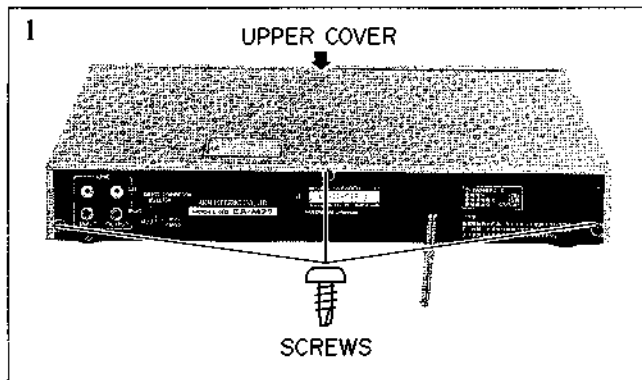
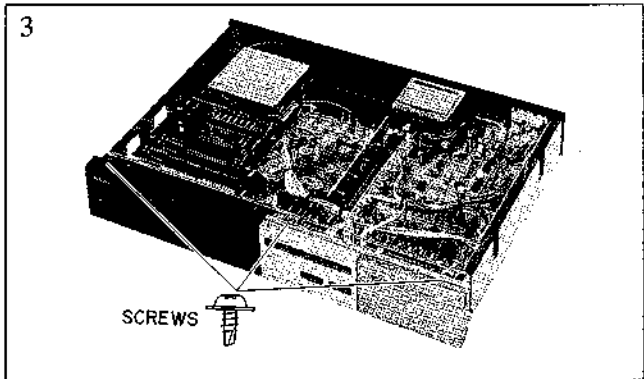

### III. CONTROLS

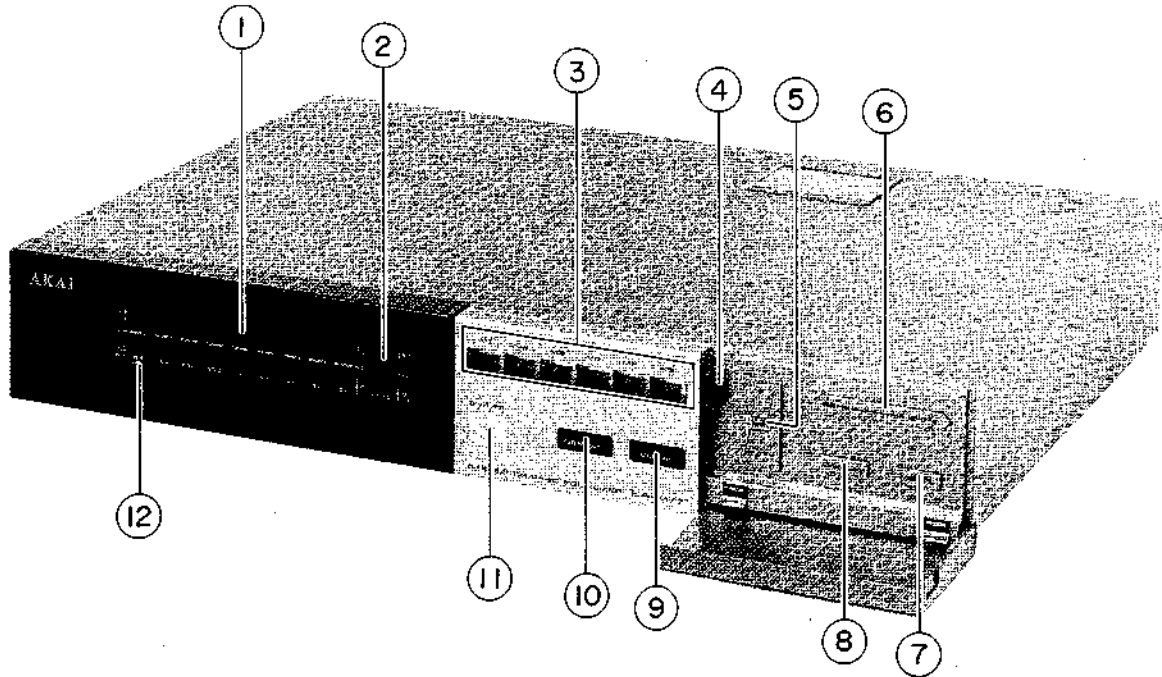

Fig. 3-1



Fig. 3-2

- |                                   |                                       |
|-----------------------------------|---------------------------------------|
| 1. SPECTRUM FL DISPLAY            | 10. DEFEAT BUTTON                     |
| 2. FULL RANGE DISPLAY             | 11. ON/OFF (POWER) SWITCH             |
| 3. MEMORY BUTTONS                 | 12. LEVEL CONTROL INDICATOR           |
| 4. MEMORY CARD HOLDER             | 13. LINE IN JACKS                     |
| 5. FREQUENCY LEVEL CONTROL BUTTON | 14. LINE OUT JACKS                    |
| 6. BAND SELECT BUTTON             | 15. DIRECT CONNECTION SELECTOR SWITCH |
| 7. MEMO BUTTON                    | 16. AC INLET (E.V.B.S. model only)    |
| 8. DISPLAY BUTTON                 | 17. AC POWER CORD                     |
| 9. CURVE BUTTON                   | 18. VOLTAGE SELECTOR (□ model only)   |

## IV. PRINCIPAL PARTS LOCATION

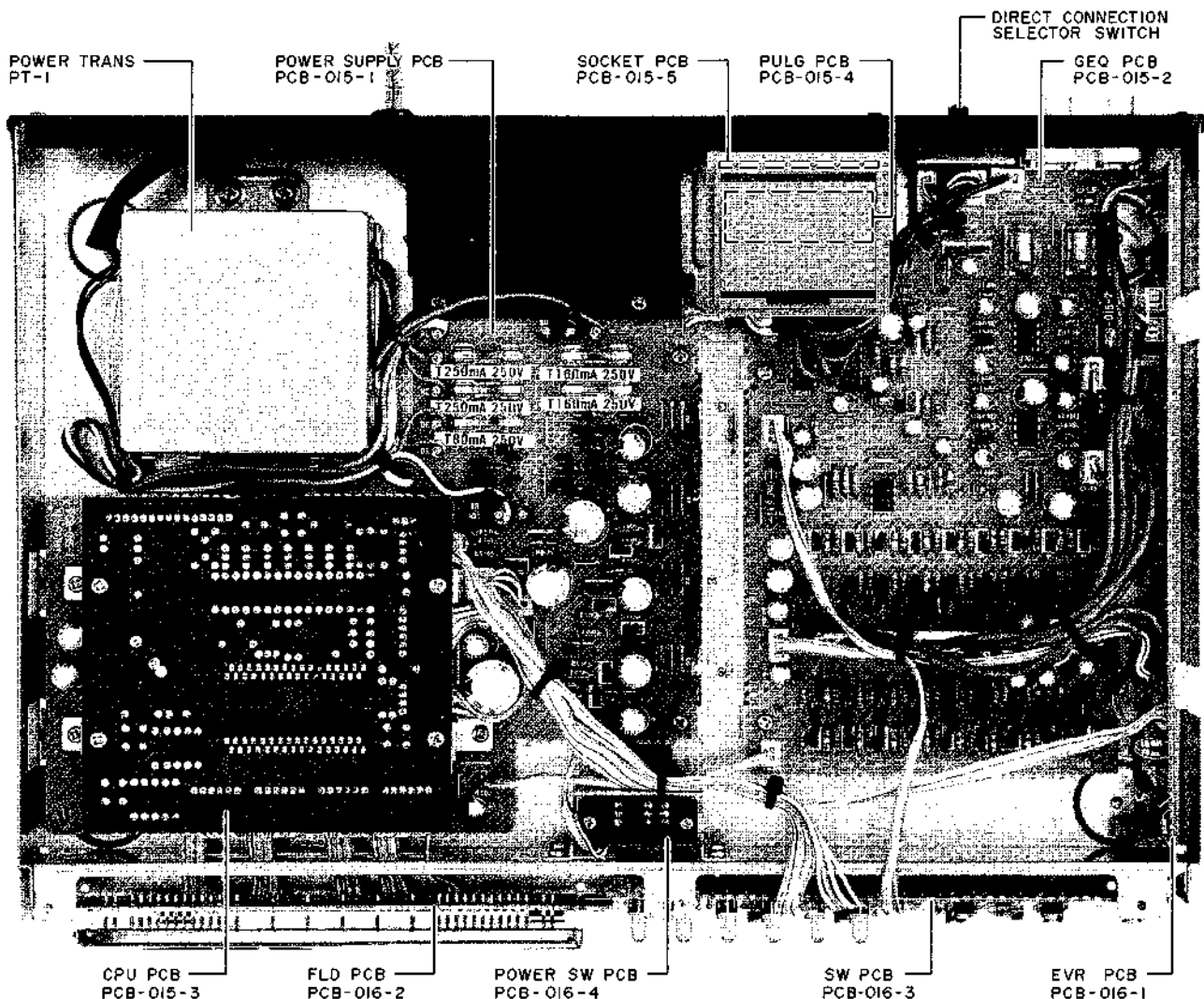

Fig. 4-1 View from Top Side

## V. P.C BOARD TITLES AND IDENTIFICATION NUMBERS

### P.C BOARD TITLES

P.C BOARD TITLE	P.C BOARD NUMBER
POWER SUPPLY P.C BOARD	PCB-015-1
GEQ P.C BOARD	PCB-015-2
CPU P.C BOARD	PCB-015-3
FLD P.C BOARD	PCB-016-2
SW P.C BOARD	PCB-016-3
EVR P.C BOARD	PCB-016-1
POWER SW P.C BOARD	PCB-016-4
SOCKET P.C BOARD	PCB-015-5
PLUG P.C BOARD	PCB-015-4



---

SECTION 2

**PARTS LIST**

TABLE OF CONTENTS

RECOMMENDED SPARE PARTS .....	9
1. GRAPHIC EQUALIZER P.C BOARD BLOCK .....	10
2. EVR P.C BOARD BLOCK .....	10
3. ASSEMBLY BLOCK .....	11
4. FINAL ASSEMBLY BLOCK .....	12
INDEX .....	12

Resistor and Capacitor which is not listed in this parts list, please refer to  
COMMON LIST FOR SERVICE PARTS.

## ATTENTION

When placing an order for parts, be sure to list the part no., model no., and description. There are instances in which any of this information is omitted, parts cannot be shipped or the wrong parts will be delivered. Please be careful not to make a mistake in the part no. If the part no. is in error, a part different from the one ordered may be delivered. Because part number and part quantity in the Preliminary Parts List may be partially changed, please use this parts list for all future reference.

## HOW TO USE THIS PARTS LIST

1. This Parts List shows the parts that are considered necessary for repairs. Other parts, such as resistors and capacitors, are shown in the "Common List for Service Parts". Select and order such parts from the "Common List for Service Parts".
2. The Recommended Spare Parts shows those parts in the Parts List which are considered particularly important for service.
3. Parts not shown in the Parts List and "Common List for Service Parts" will not be supplied in principle.
4. How to read list
  - a) Mechanism Block
  - b) P.C Board Block

### 2. HEAD BASE BLOCK

REF. NO.	PARTS NO.	DESCRIPTION
2-1x	BH-T2023A320A	HEAD BASE BLOCK GX-F66R
2-2	HP-H2206A010A	HEAD R/P PR4-3FU C
2-3	ZS-477876	PAN20x03STL CMT
2-4	ZS-536488	BID20x08STL CMT
2-5	ZG-402895	CS ANGLE ADJUST SPRING

SP (Service Parts) Classification

A small "x" indicates the inability to show that particular part in the Photo or Illustration.

This number corresponds with the individual parts index number in that figure

This number corresponds with the Figure Number

### 6. SYS. CON. P.C BOARD BLOCK

REF. NO.	PARTS NO.	DESCRIPTION
6-1	BA-T2034A070A	PC SYS CON BLK GX-F44R
6-IC1	EI-324536	IC HD14049BP
6-IC2	EI-336801	IC MB8841-564M
6-IC3	EI-331661	IC SN7405N
6-IC4	EI-336725	IC M54527P
6-TR1to4	ET-200985	TR 2SC2603 F,G
6-TR5to28	ET-554657	TR 2SA733A P,Q
6-D1	ED-318292	D SILICON H 1S2473T-77 T26
6-D2to4	ED-308952	D GERMA V 1K34A-LR F07
6-D5to10	ED-318292	D SILICON H 1S2473T-77 T26
6-X1	EI-318384	OSC X'TAL NC-18C 3.579545MHZ

SP (Service Parts) Classification

This reference numbers corresponds with symbol numbers of Schematic Diagrams.

5. Both the kind of part and installation position can be determined by the Parts Number. To determine where a parts number is listed, utilize Parts Index at end of Parts List. It is necessary first of all to find the Parts Number. This can be accomplished by using the Reference Number listed at right of parts number in the Parts Index.

## WARNING

▲ INDICATES SAFETY CRITICAL COMPONENTS FOR CONTINUED SAFETY. REPLACE SAFETY CRITICAL COMPONENTS ONLY WITH MANUFACTURER'S RECOMMENDED PARTS.

## AVERTISSEMENT

▲ IL INDIQUE LES COMPOSANTS CRITIQUES DE SECURITE POUR MAINTENIR LE DEGRE DE SECURITE DE L'APPAREIL. NE REMPLACER QUE DES PIECES RECOMMANDEES PAR LE FABRICANT.

## RECOMMENDED SPARE PARTS

Because, if the parts listed below are on hand, almost any repair can be accomplished, we suggest that you stock these Recommended Spare Parts Items.

REF. NO.	PARTS NO.	DESCRIPTION
1	BT-712576	△ TRANS POWER PPT-009(J) (J)
2	BT-712577	△ TRANS POWER PPT-010(A,C) (A,C)
3	BT-712578	△ TRANS POWER PPT-011(E,V)(E,V)
4	BT-712579	△ TRANS POWER PPT-012(B,S)(B,S)
5	BT-712580	△ TRANS POWER PPT-013(U)(U)
6	ED-344444	D LED SLP436B YLW
7	ED-712568	D SILICON H DSF10B
8	ED-557447	D SILICON H 1S1588
9	ED-308860	D ZENER H RD16E B
10	ED-200969	D ZENER H RD3.0E B2
11	ED-305465	D ZENER H RD33E B
12	ED-305441	D ZENER H RD5.6E B
13	ED-703193	D ZENER H RD8.2E B
14	ED-300269	D ZENER H RD9.1E B
15	EF-339901	△ FUSE SEMKO T 250V 0.08A(U,J,E,V,B,S)
16	EF-339904	△ FUSE SEMKO T 250V 0.16A(U,J,E,V,B,S)
17	EF-339906	△ FUSE SEMKO T 250V 0.25A(U,J,E,V,B,S)
18	N EF-713031	△ FUSE TSC 125V 0.2A (C,A)
19	EF-315334	△ FUSE TSC 125V 0.25A (C,A)
20	N EF-713032	△ FUSE TSC 125V 0.25A (C,A)
21	EI-712567	IC L78N06
22	EI-306727	IC TC4013BP
23	EI-3377324	IC TC4016BP
24	EI-712581	IC TC9170P
25	EI-301748	IC UPC1458C
26	EI-318332	IC UPC339C
27	EI-712563	IC UPC393C
28	EI-704424	IC UPC4558C
29	EI-712562	IC UPD7519G
30	EM-712570	IND FL F1P10BW19Y
31	EQ-712575	RELAY POWER G5A237P
32	WS-709333	△ SW SELECTER HXW-0103-01-610(U)(VS-1)
33	ES-712571	SW PUSH ESB-645 TYPE 3
34	ES-712574	SW SLIDE SSB342
35	ES-336780	SW TACT KHH10902
36	ET-709752	TR 2SA1175 J,H,F,E
37	ET-353067	TR 2SB744 P,Q,R
38	ET-712565	TR 2SB810
39	ET-709750	TR 2SC2785 J.H.F
40	ET-712566	TR 2SD1020
41	ET-349979	TR 2SD794 P,Q,R

"NOTE" N: New Parts

### SYMBOL FOR DESTINATION

- A : AAL (U.S.A.)
- B : UK (England)
- C : CSA (Canada)
- E : CEE (Europe)
- J : JPN (Japan)
- S : SAA (Australia)
- U : U/T (Universal Area)
- V : VDE (West Germany)

## 1. GRAPHIC EQUALIZER P.C BOARD BLOCK

REF. NO.	PARTS NO.	DESCRIPTION
1-1	BA-712848	PC EQ BLK EA-M77
<b>GRAPHIC EQUALIZER P.C BOARD</b>		
1-IC201,301	EI-704424	IC UPC4558C
1-IC401	EI-306727	IC TC4013BP
1-IC402	EI-337324	IC TC4016BP
1-IC404	EI-301748	IC UPC1458C
1-TR201		
to 209	ET-709750	TR 2SC2785 J.H.F
1-TR401	ET-709750	△ TR 2SC2785 J.H.F
1-TR402	ET-712565	TR 2SB810
1-TR403		
to 405	ET-709750	TR 2SC2785 J.H.F
1-D201,202	ED-305441	D ZENER H RDS.6E B
1-D401	ED-557447	D SILICON H 1S1588
1-D402	ED-557447	△ D SILICON H 1S1588
1-D403	ED-712568	△ D SILICON H DSF10B
1-D404,405	ED-557447	D SILICON H 1S1588
1-RY501,502	EQ-712575	RELAY POWER GSA237P
1-SW201	ES-712574	SW SLIDE SSB342
1-PJ101	EJ-709341	PIN J 4P PJK-004
<b>POWER SUPPLY P.C BOARD</b>		
1-IC405		
to 409	EI-301748	IC UPC1458C
1-IC410	EI-712563	IC UPC393C
1-IC411,412	EI-318332	IC UPC339C
1-TR415	ET-709750	TR 2SC2785 J.H.F
to 419	ET-709750	TR 2SC2785 J.H.F
1-TR421	ET-709752	TR 2SA1175 J,H,F,E
1-TR422,		
TR423	ET-712566	TR 2SD1020
1-D101		
to 104	ED-712568	△ D SILICON H DSF10B
1-D105,106	ED-308860	△ D ZENER H RD16E B
1-D107		
to 112	ED-712568	△ D SILICON H DSF10B
1-D113	ED-305465	△ D ZENER H RD33E B
1-D114	ED-703193	D ZENER H RD8.2E B
1-D406		
to 413	ED-557447	D SILICON H 1S1588
1-D418,419	ED-557447	D SILICON H 1S1588
1-D420	ED-200969	D ZENER H RD3.0E B2
1-D421	ED-557447	D SILICON H 1S1588
1-D422	ED-557447	△ D SILICON H 1S1588
1-D440		
to 442	ED-557447	D SILICON H 1S1588
1-F101U	EF-339904	△ FUSE SEMKO T 250V 0.16V (U,J,E,V,B,S)
1-F101C	EF-713031	△ FUSE TSC 125V 0.2A (C,A)
1-F102U	EF-339904	△ FUSE SEMKO T 250V 0.16A (U,J,E,V,B,S)
1-F102C	EF-713031	△ FUSE TSC 125V 0.2A (C,A)
1-F103U	EF-339906	△ FUSE SEMKO T 250V 0.25A (U,J,E,V,B,S)
1-F103C	EF-315334	△ FUSE TSC 125V 0.25A (C,A)
1-F104U	EF-339906	△ FUSE SEMKO T 250V 0.25A (U,J,E,V,B,S)
1-F104C	EF-713032	△ FUSE TSC 125V 0.25A (C,A)
1-F105U	EF-339901	△ FUSE SEMKO T 250V 0.08A (U,J,E,V,B,S)
1-F105C	EF-713032	△ FUSE TSC 125V 0.25A (C,A)

REF. NO.	PARTS NO.	DESCRIPTION
<b>CPU P.C BOARD</b>		
1-IC403	EI-712562	IC UPD7519G
1-TR407	ET-709752	TR 2SA1175 J,H,F,E
1-TR408		
to 413	ET-709750	TR 2SC2785 J.H.F
1-D436,437	ED-557447	D SILICON H 1S1588
1-D438	ED-557447	△ D SILICON H 1S1588
1-D439	ED-300269	D ZENER H RD9.1E B
1-X401	EH-347437	COMP R EXB-P88104K
1-L401	EO-443722	COIL FIX 1 FL09H 102J
1-C460	EC-713033	C COUPLE LAYER 474Z 5.5VDC

## 2. EVR P.C BOARD BLOCK

REF. NO.	PARTS NO.	DESCRIPTION
<b>EVR P.C BOARD</b>		
2-IC202		
to 210	EI-712581	IC TC9170P
2-TR414	ET-709750	TR 2SC2785 J.H.F
2-TR420	ET-709752	TR 2SA1175 J,H,F,E
<b>SW P.C BOARD</b>		
2-TR406	ET-709750	TR 2SC2785 J.H.F
2-D423		
to 435	ED-557447	D SILICON H 1S1588
2-LED401		
to 406	ED-344444	D LED SLP436B YLW
2-SW401		
to 414	ES-336780	SW TACT KHH10902
<b>FLD P.C BOARD</b>		
2-FLD1	EM-712570	IND FL F1P10BW19Y
<b>POWER SW P.C BOARD</b>		
2-SW101	ES-712571	SW PUSH ESB-645 TYPE 3

# ASSEMBLY BLOCK

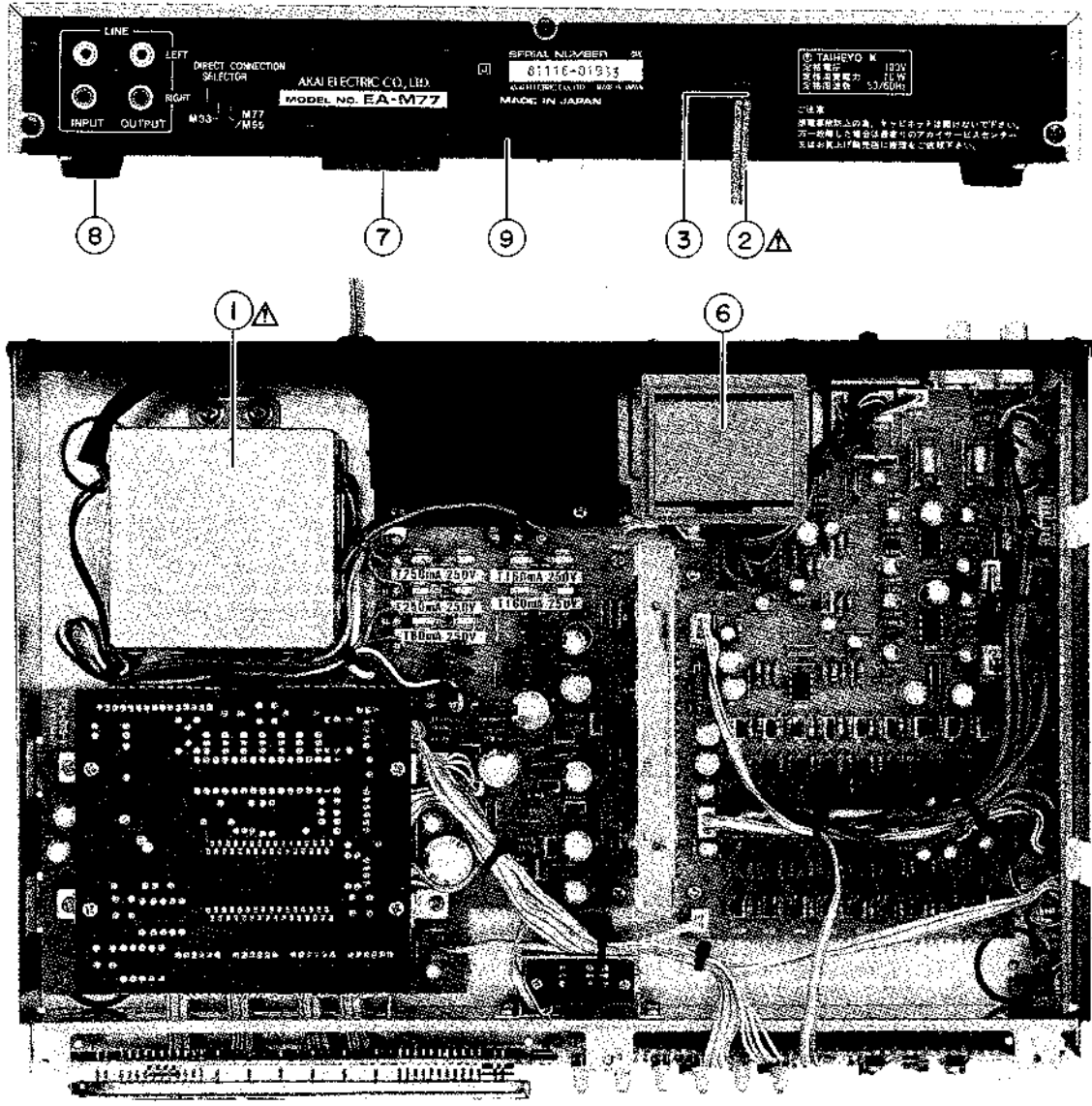

## 3. ASSEMBLY BLOCK

REF. NO.	PARTS NO.	DESCRIPTION	REF. NO.	PARTS NO.	DESCRIPTION
<b>POWER SUPPLY P.C BOARD</b>					
3-IC101	EI-712567	△ IC L78N06	3-2E	EW-315767	△ AC CORD 2 CORES KP-419C/KS-15 EV (E,V)
3-TR101	ET-349979	△ TR 2SD794 P,Q,R	3-2B	EW-322400	△ AC CORD 2 CORES KS-15/GTBS-2F B
3-TR102,103	ET-3353067	△ TR 2SB744 P,Q,R	3-2S	EW-322401	△ AC CORD 2 CORES KP-560/KS-15 S
<b>ASSEMBLY BLOCK</b>					
3-1J	BT-712576	TRANS POWER PPT-009(J) (PT-1(J))	3-3	EZ-631945	STRAIN RELIEF SR-4N-4
3-1A	BT-712577	TRANS POWER PPT-010 (A,C) (PT-1(A,C))	3-4x	EJ-301513	△ SOCKET INLET S-16453 E 2P (E,V,B,S)
3-1E	BT-712578	TRANS POWER PPT-011(E,V) (PT-1(E,V))	3-5x	ES-709333	△ SW SELECTER HXW-0103-01-610 (VS-1)(U)
3-1B	BT-712579	TRANS POWER PPT-012(B,S) (PT-1(B,S))	3-6	EJ-351021	SOCKET CONNECTER M1701 12P (J1)
3-1U	BT-712580	TRANS POWER PPT-013(U) (PT-1(U))	3-7	EJ-350918	PLUG CONNECTER M1690 12P (J2)
3-2J	EW-349435	AC CORD 2 CORES KP-224, VFF AM-7 J	3-8	SA-710514	RUBBER FOOT EA-M7
3-2A	EW-305691	AC CORD 2 CORES KP-8, SPT-1 UC (A,C)	3-9J	SP-712770	PANEL REAR EA-M77 (J)
3-2U	EW-349434	AC CORD 2 CORES KP-224, VFF AM-7 U/T	3-9E	SP-712771	PANEL REAR EA-M77 (E,V)
			3-9B	SP-712772	PANEL REAR EA-M77 (B,S) (B,S)
			3-9A	SP-712773	PANEL REAR EA-M77 (A,C) (A,C)
			3-9U	SP-712774	PANEL REAR EA-M77 (U)

**FINAL ASSEMBLY BLOCK**

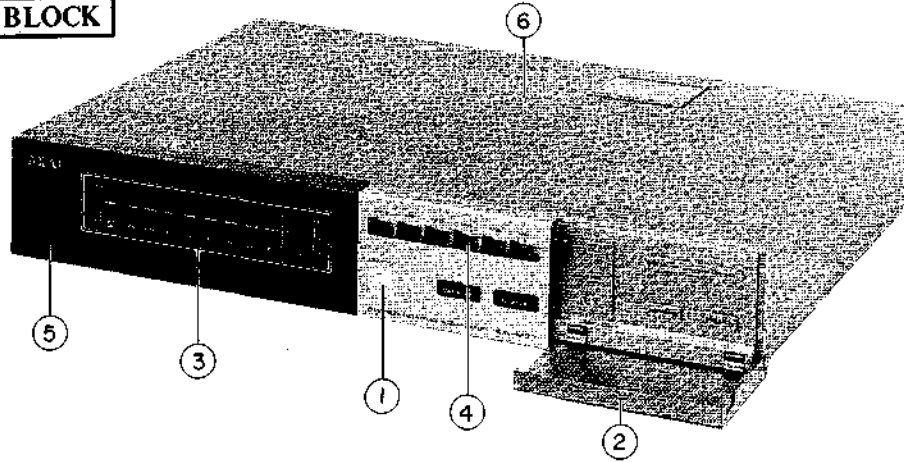

**4. FINAL ASSEMBLY BLOCK**

REF. NO.	PARTS NO.	DESCRIPTION
4-1	BD-712850	PANEL FRONT BLK EA-M77
4-2	SP-712849	PNAEL DOOR
4-3	SE-350848	MASK FLD
4-4	SP-350844	WINDOW MEMORY
4-5	SE-350857A	WINDOW FLD
4-6	SP-712769	COVER UPPER

**INDEX**

PARTS NO.	REF. NO.	PARTS NO.	REF. NO.	PARTS NO.	REF. NO.	PARTS NO.	REF. NO.	PARTS NO.	REF. NO.
BA-712848	1-1	ED-557447	1-D418	EI-301748	1-IC404	ES-336780	2-SW403	ET-712565	1-TR402
BD-712850	4-1	ED-557447	1-D440	EI-301748	1-IC408	ES-336780	2-SW410	ET-712566	1-TR422
BT-712576	3-1J	ED-557447	1-D413	EI-301748	1-IC406	ES-336780	2-SW407	ET-712566	1-TR423
BT-712577	3-1A	ED-557447	2-D433	EI-301748	1-IC405	ES-336780	2-SW411	EW-305691	3-2A
BT-712578	3-1E	ED-557447	2-D431	EI-301748	1-IC407	ES-336780	2-SW413	EW-315767	3-2E
BT-712579	3-1B	ED-557447	2-D430	EI-306727	1-IC401	ES-709333	3-5x	EW-322400	3-2B
BT-712580	3-1U	ED-557447	2-D423	EI-318332	1-IC411	ES-712571	2-SW101	EW-322401	3-2S
EC-713033	1-C460	ED-557447	2-D428	EI-318332	1-IC412	ES-712574	1-SW201	EW-349434	3-2U
ED-200969	1-D420	ED-557447	2-D435	EI-337324	1-IC402	ET-349979	3-TR101	EW-349435	3-2J
ED-300269	1-D439	ED-557447	2-D429	EI-704424	1-IC201	ET-353067	3-TR103	EZ-631945	3-3
ED-305441	1-D202	ED-557447	2-D432	EI-704424	1-IC301	ET-353067	3-TR102	SA-710514	3-8
ED-305441	1-D201	ED-557447	2-D424	EI-712562	1-IC403	ET-709750	1-TR412	SE-350848	4-3
ED-305465	1-D113	ED-557447	2-D426	EI-712563	1-IC410	ET-709750	1-TR409	SE-350857A	4-5
ED-308860	1-D105	ED-557447	2-D434	EI-712567	3-IC101	ET-709750	1-TR401	SP-350844	4-4
ED-308860	1-D106	ED-557447	2-D425	EI-712581	2-IC210	ET-709750	1-TR205	SP-712769	4-6
ED-344444	2-LED401	ED-557447	2-D427	EI-712581	2-IC208	ET-709750	1-TR405	SP-712770	3-9J
ED-344444	2-LED405	ED-703193	1-D114	EI-712581	2-IC202	ET-709750	1-TR204	SP-712771	3-9E
ED-344444	2-LED402	ED-712568	1-D112	EI-712581	1-IC209	ET-709750	1-TR206	SP-712772	3-9B
ED-344444	2-LED403	ED-712568	1-D104	EI-712581	2-IC204	ET-709750	1-TR201	SP-712773	3-9A
ED-344444	2-LED404	ED-712568	1-D111	EI-712581	2-IC205	ET-709750	1-TR202	SP-712774	3-9U
ED-344444	2-LED406	ED-712568	1-D102	EI-712581	2-IC203	ET-709750	1-TR419	SP-712849	4-2
ED-557447	1-D401	ED-712568	1-D403	EI-712581	2-IC207	ET-709750	1-TR415		
ED-557447	1-D421	ED-712568	1-D109	EI-712581	2-IC206	ET-709750	1-TR403		
ED-557447	1-D412	ED-712568	1-D107	EJ-301513	3-4x	ET-709750	1-TR410		
ED-557447	1-D405	ED-712568	1-D103	EJ-350918	3-7	ET-709750	1-TR208		
ED-557447	1-D404	ED-712568	1-D110	EJ-351021	3-6	ET-709750	1-TR413		
ED-557447	1-D419	ED-712568	1-D108	EJ-709341	1-PJ101	ET-709750	1-TR411		
ED-557447	1-D410	ED-712568	1-D101	EM-712570	2-FLD1	ET-709750	1-TR408		
ED-557447	1-D422	EF-315334	1-F103C	EO-443722	1-L401	ET-709750	1-TR417		
ED-557447	1-D436	EF-339901	1-F105U	EQ-712575	1-RY502	ET-709750	1-TR207		
ED-557447	1-D406	EF-339904	1-F101U	EQ-712575	1-RY501	ET-709750	1-TR209		
ED-557447	1-D441	EF-339904	1-F102U	ES-336780	2-SW412	ET-709750	1-TR404		
ED-557447	1-D408	EF-339906	1-F104U	ES-336780	2-SW408	ET-709750	1-TR203		
ED-557447	1-D437	EF-339906	1-F103U	ES-336780	2-SW404	ET-709750	1-TR416		
ED-557447	1-D442	EF-713031	1-F102C	ES-336780	2-SW402	ET-709750	1-TR418		
ED-557447	1-D411	EF-713031	1-F101C	ES-336780	2-SW414	ET-709750	2-TR406		
ED-557447	1-D409	EF-713032	1-F104C	ES-336780	2-SW401	ET-709750	2-TR414		
ED-557447	1-D438	EF-713032	1-F105C	ES-336780	2-SW409	ET-709752	1-TR407		
ED-557447	1-D402	EH-347437	1-X401	ES-336780	2-SW406	ET-709752	1-TR421		
ED-557447	1-D407	EI-301748	1-IC409	ES-336780	2-SW405	ET-709752	2-TR420		



LOCATION OF COMPONENTS

IC'S

- IC201-----C1
- IC301-----D1
- IC401,402-----D3
- IC404-----C3

TR'S

- TR201 to 203-----A1
- TR204 to 206-----A2
- TR207 to 209-----A3
- TR201b to 203b-----B1
- TR204b to 206b-----B2
- TR207b to 209b-----B3
- TR401,402-----E2
- TR403-----C2
- TR404-----D2
- TR405-----D3

TERMINALS

- CN201-----E1
- CN202,203-----E2
- CN206-----C1
- CN207-----B1
- CN208-----B2
- CN209-----B3
- CN306-----D1
- CN401-----D3
- CN402-----C3
- CN403-----B3
- CN404-----A3

-PNP TRANSISTOR

-NPN TRANSISTOR

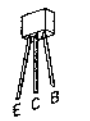

2SB810  
2SC2785

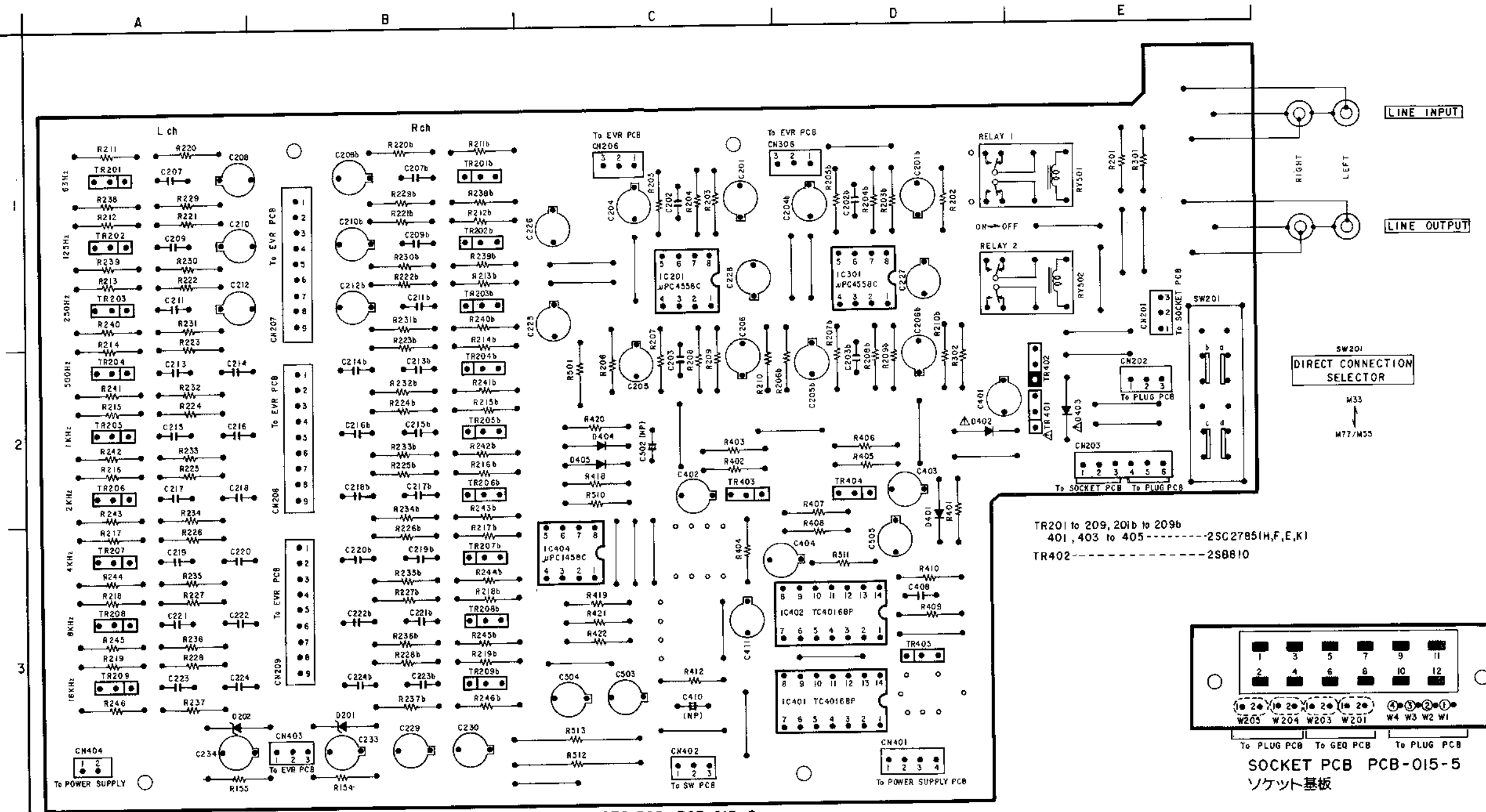

GEQ PCB PCB-015-2  
GEQ基板

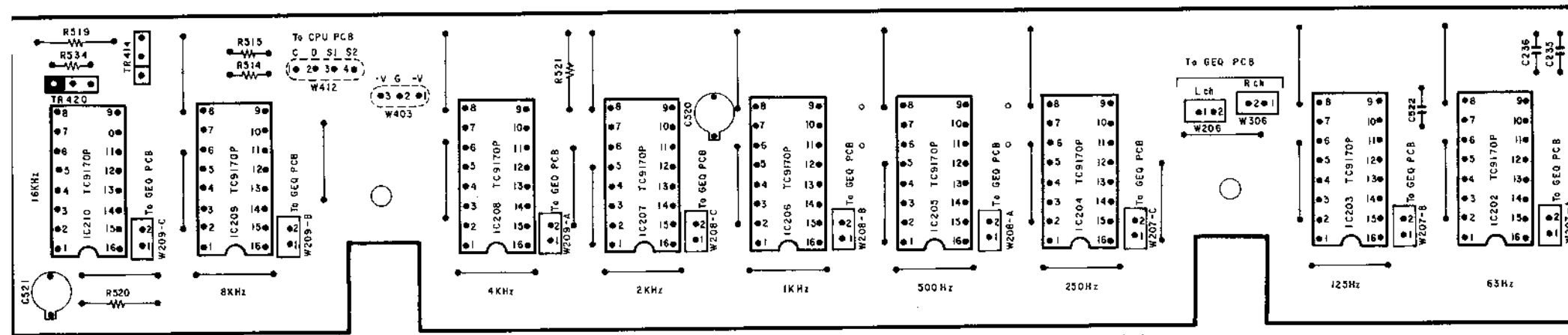

EVR PCB PCB-016-1  
EVR基板

-PNP TRANSISTOR

-NPN TRANSISTOR

TR414---2SC2785(H,F,E,K)  
TR420---2SA1175

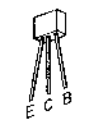

2SA1175  
2SC2785

TR201 to 209, 201b to 209b  
401, 403 to 405-----2SC2785(H,F,E,K)  
TR402-----2SB810

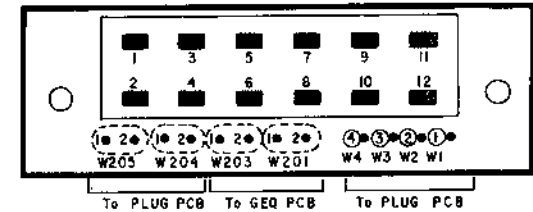

SOCKET PCB PCB-015-5  
ソケット基板

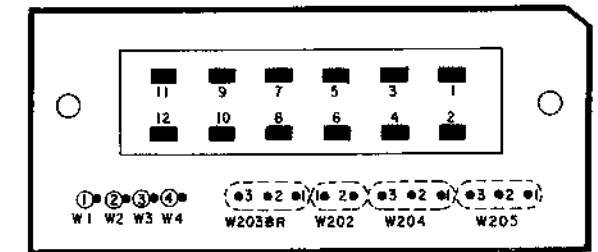

PLUG PCB PCB-015-4  
プラグ基板

注意: △の付された部品は、安全上重要部品です。交換の際は、指定部品以外は使用しないこと。

WARNING: △ INDICATES SAFETY CRITICAL COMPONENTS. FOR CONTINUED SAFETY, REPLACE SAFETY CRITICAL COMPONENTS ONLY WITH MANUFACTURER'S RECOMMENDED PARTS.

注意: △の付された部品は、安全上重要部品です。交換の際は、指定部品以外は使用しないこと。

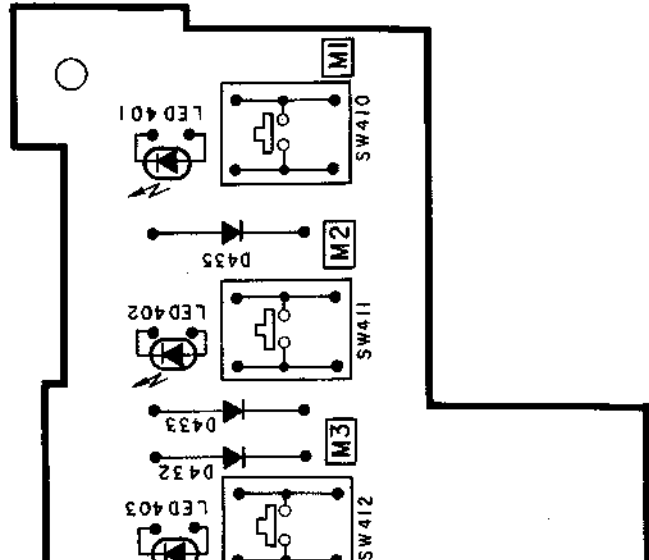

- 016 - 3

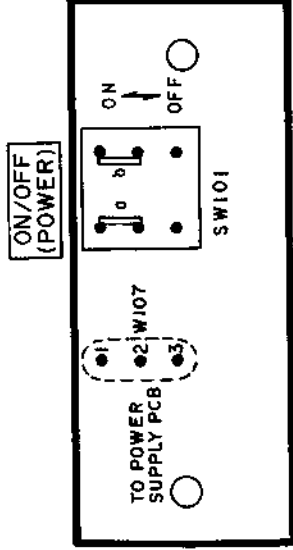

POWER SW PCB PCB-016-4  
電源 スイッチ基板

注意: △の付いた部品は、安全上重要部品であり、交換の際は、取扱説明書以外は使用しないこと。  
 WARNINGS: △ INDICATES SAFETY CRITICAL COMPONENTS.  
 FOR CONTINUED SAFETY, REPLACE SAFETY CRITICAL COMPONENTS  
 ONLY WITH MANUFACTURER'S RECOMMENDED PARTS.  
 MENTIONNEMENT: △ IL L'INDIQUE LES COMPOSANTS CRITIQUES EN SÉCURITÉ. NE REMPLACEZ QUE LES COMPOSANTS RECOMMANDÉS PAR LE FABRICANT.  
 QUE PAR DES PIÈCES RECOMMANDÉES PAR LE FABRICANT.

- LOCATION OF COMPONENTS
- IC'S  
 IC101-----B5  
 IC405-----D1  
 IC406,407---D2  
 IC408,409---D3  
 IC410-----D2  
 IC411,412---C2
- TR'S  
 TR101,102---C5  
 TR103-----D5  
 TR415 to 417---C5  
 TR418,419---D5  
 TR421-----C5  
 TR422,423---C4
- TERMINALS  
 CN107-----C4  
 W401-----A5  
 W404-----D4  
 CN405-----C3  
 W406,407---C2  
 W408-----C1  
 ①,③-----A3  
 ②,④,⑤,⑦---A4  
 ⑥-----A5  
 ⑧,⑨-----A3  
 ⑩ to ⑫---B3  
 ⑬ to ⑮---C4

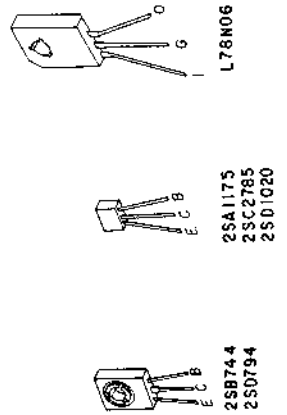
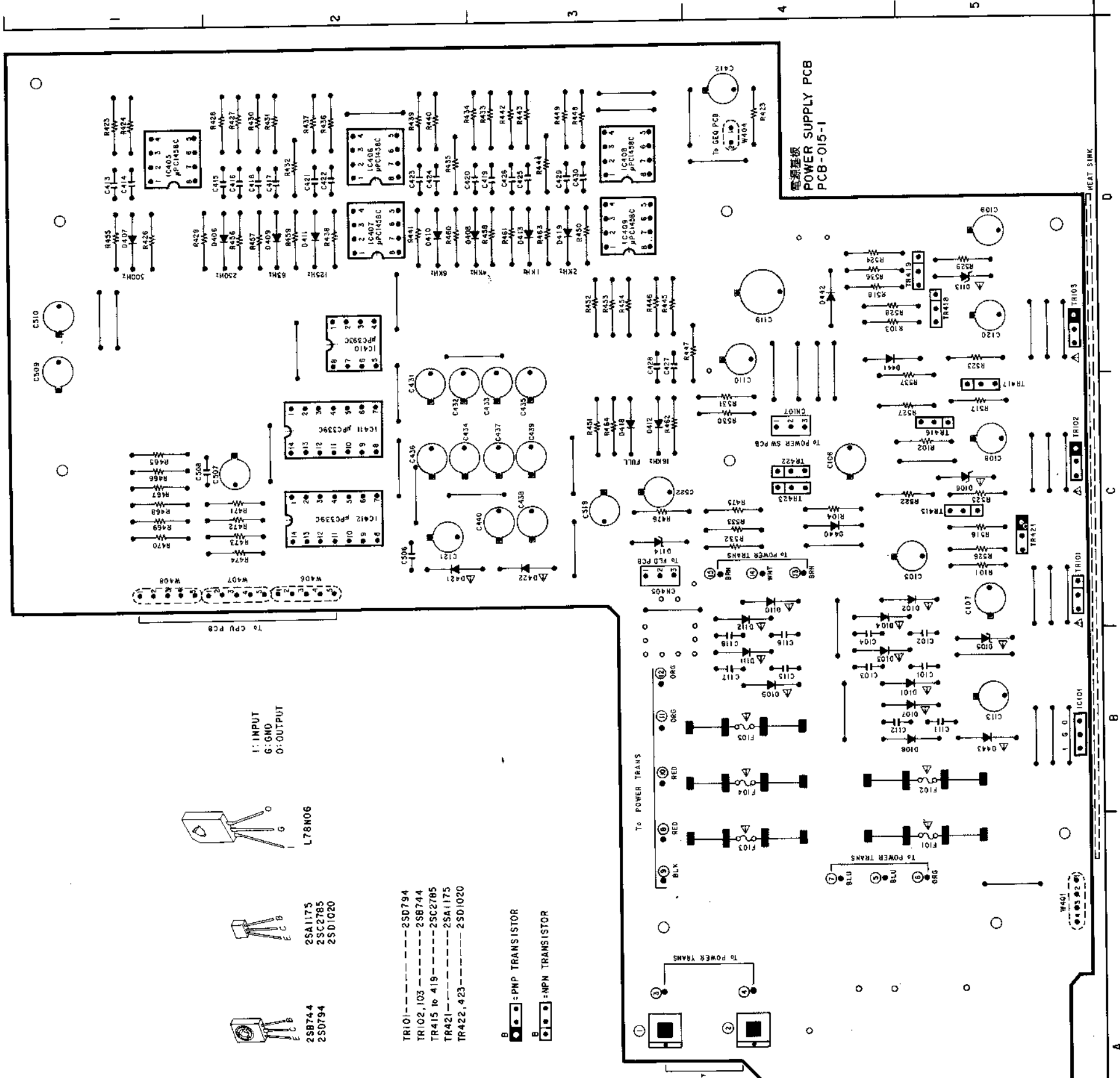

- TR101-----2SD794  
 TR102,103---2SB744  
 TR415 to 419---2SC2785  
 TR421-----2SA1175  
 TR422,423---2SD1020

●●●=PNP TRANSISTOR  
 ●●●=NPN TRANSISTOR



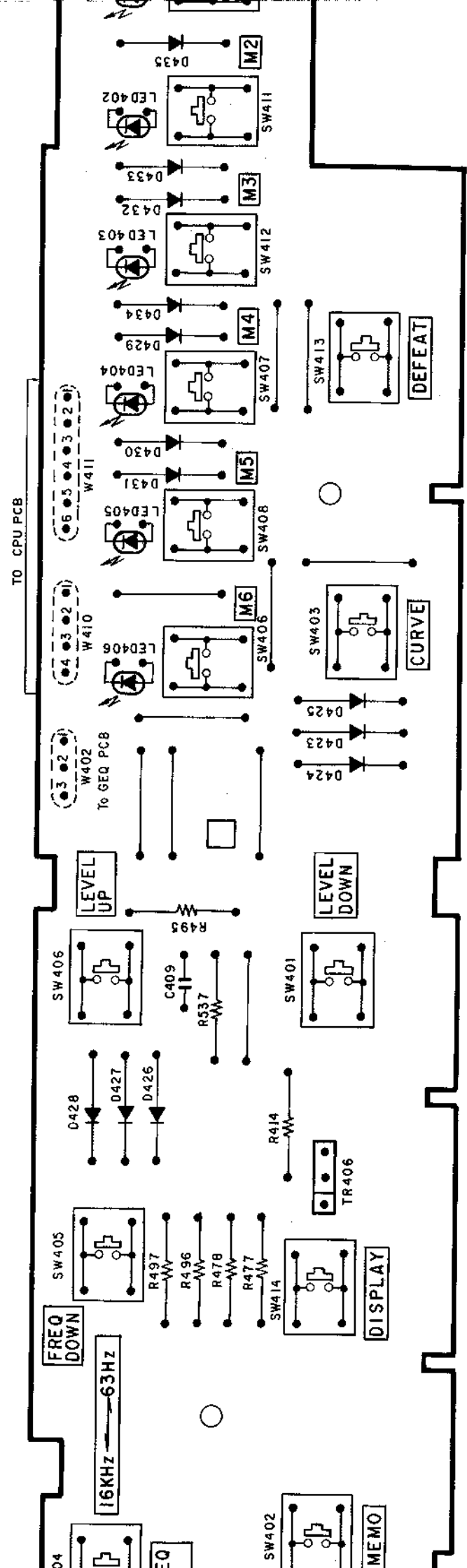

SW PCB PCB-016-3  
スイッチ基板

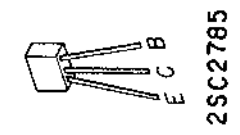

TR406 --- 2SC2785(H,F,E,K)

TR406 --- NPN TRANSISTOR

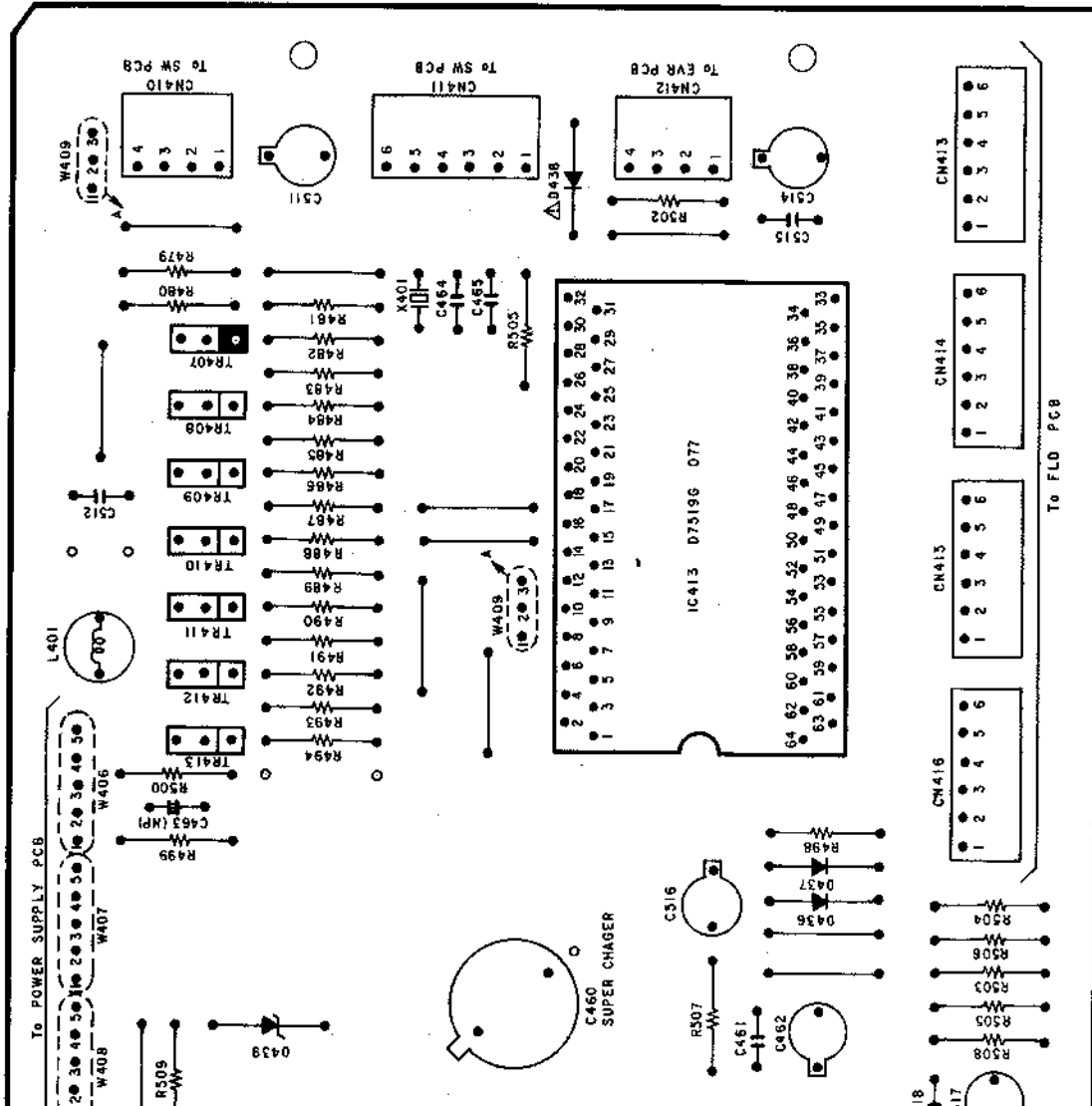

CPU PCB PCB-015-3  
CPU基板

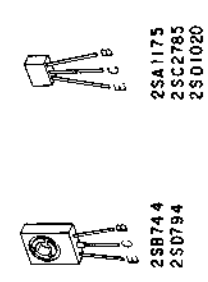

- TR101 --- 2SD794
- TR102, 103 --- 2SB744
- TR415 to 419 --- 2SC2785
- TR421 --- 2SA1175
- TR422, 423 --- 2SD1020

PNP TRANSISTOR  
NPN TRANSISTOR

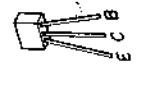

2SA1175  
2SC2875(H,F,E,K)

TR407 --- 2SA1175  
TR408 to 413 --- 2SC2875(H,F,E,K)

PNP TRANSISTOR  
NPN TRANSISTOR

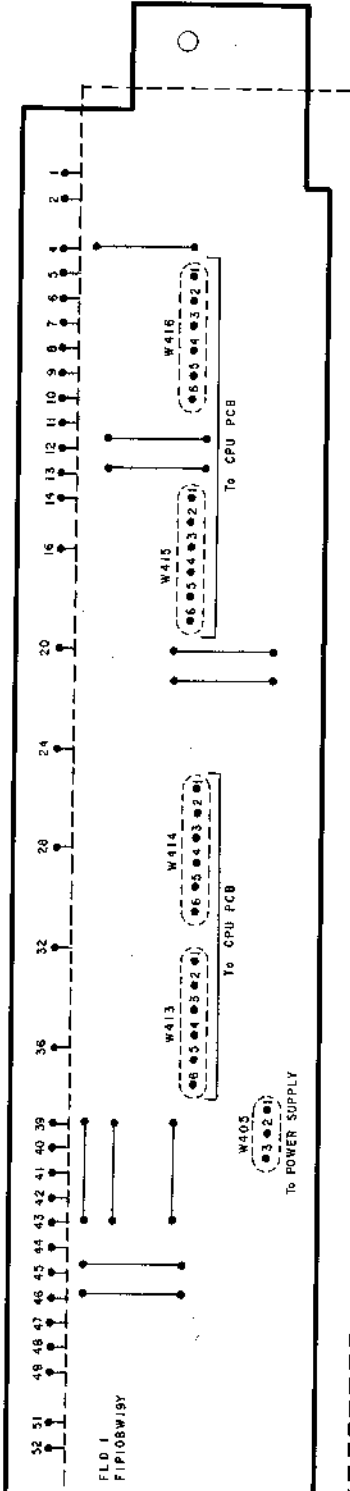

FLD PCB PCB-010-2  
FLD基板

1 2 3 4 5 6 7 8

K J I H G F

ソケット基板  
SOCKET PCB PCB-015-S

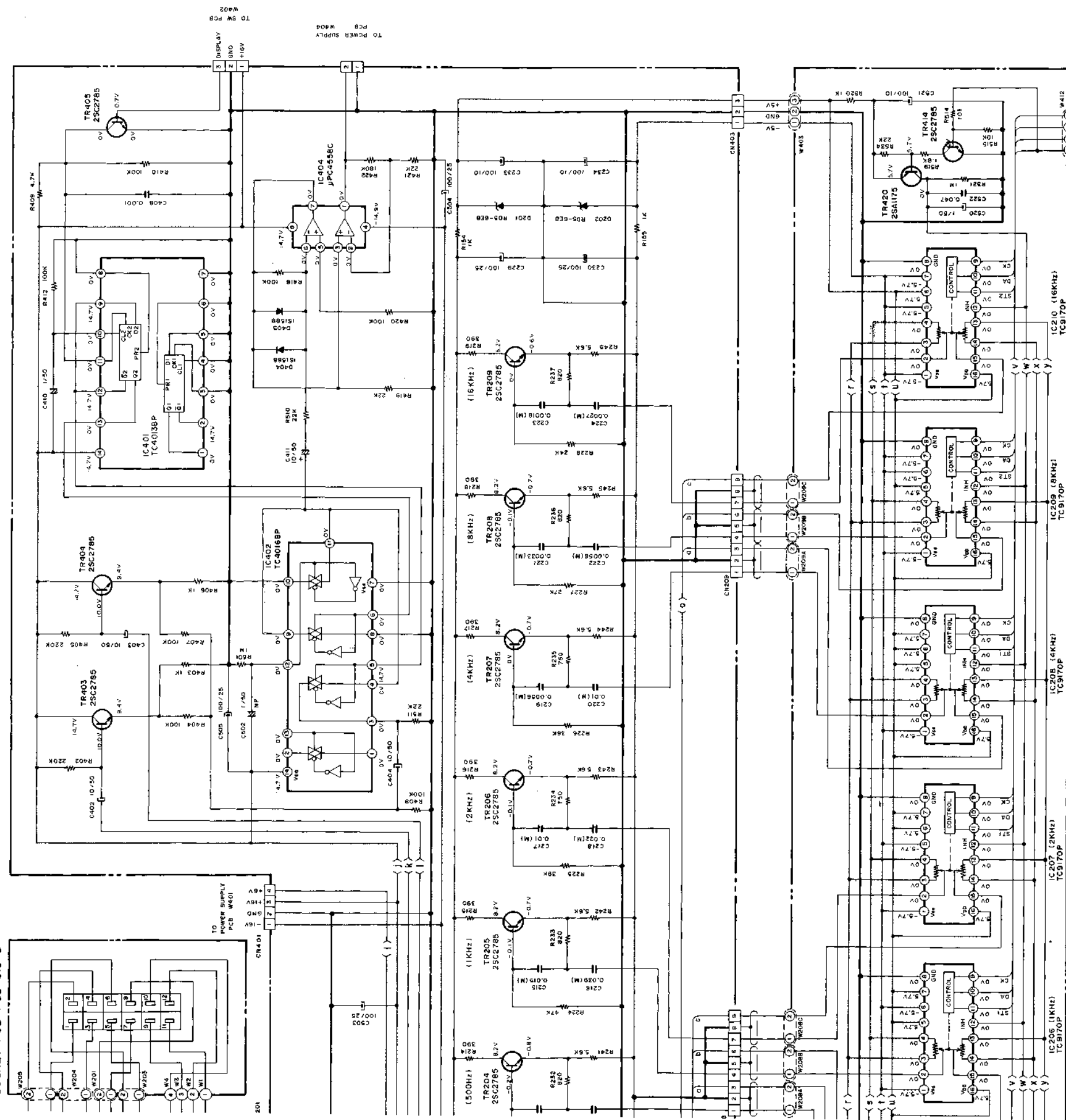

EVR基板  
EVR PCB  
PCB-016-I

①電源線 (POWER SUPPLY LINE)  
②信号線 (SIGNAL LINE)

注意: この付された部品は、安全上重要部品です。交換の際は、指定部品以外は使用しないこと。  
 WARNING: ① INDICATES SAFETY CRITICAL COMPONENTS. FOR CONTINUED SAFETY, REPLACE SAFETY CRITICAL COMPONENTS ONLY WITH MANUFACTURER'S RECOMMENDED PARTS.  
 ② INDICATES SAFETY CRITICAL COMPONENTS. FOR CONTINUED SAFETY, REPLACE SAFETY CRITICAL COMPONENTS ONLY WITH MANUFACTURER'S RECOMMENDED PARTS.  
 ③ ④ ⑤ ⑥ ⑦ ⑧ ⑨ ⑩ ⑪ ⑫ ⑬ ⑭ ⑮ ⑯ ⑰ ⑱ ⑲ ⑳ ㉑ ㉒ ㉓ ㉔ ㉕ ㉖ ㉗ ㉘ ㉙ ㉚ ㉛ ㉜ ㉝ ㉞ ㉟ ㊱ ㊲ ㊳ ㊴ ㊵ ㊶ ㊷ ㊸ ㊹ ㊺ ㊻ ㊼ ㊽ ㊾ ㊿

EA-M77 (2/2)  
SCHEMATIC DIAGRAM  
No. 2-2 840407A

NOTE  
UNLESS OTHERWISE SPECIFIED  
ALL RESISTORS IN OHMS 1/4W  
ALL CAPACITORS IN PF 50WV

備考  
C, Rの値は(特に指定された部品以外)  
接点 ..... Q / AW (J), (FS) 配線は不燃性絶縁  
コンデンサ ..... PF 50WV (J)  
電圧は、0.50Vの電圧をデジタル・マルチメーターにて  
測定した値です。

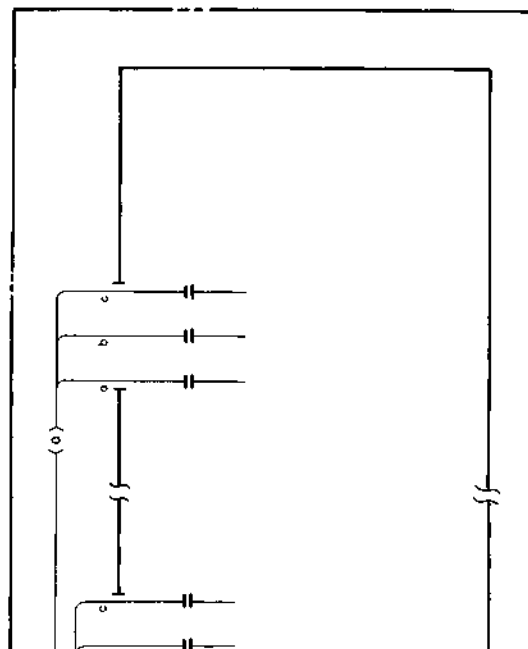

IC206 (1KHz) TC9170P  
IC207 (2KHz) TC9170P  
IC208 (4KHz) TC9170P  
IC209 (8KHz) TC9170P  
IC210 (16KHz) TC9170P

K J I H G F

A

B

C

D

E

F

GEQ基板  
GEQ PCB PCB-015-2

プラグ基板  
PLUG PCB PCB-015-4

ソケット基板  
SOCKET PCB PCB-015-5

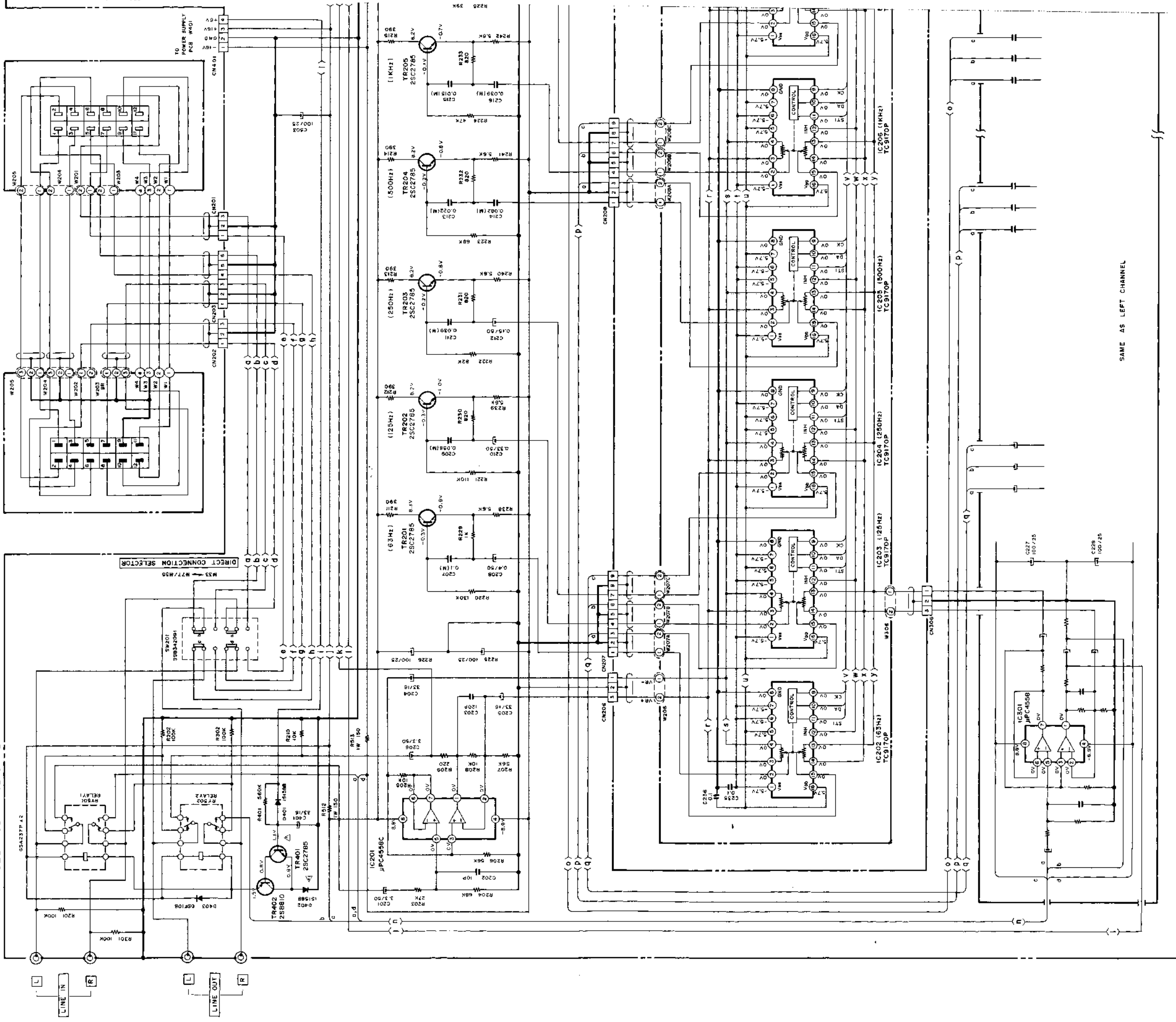

SAME AS LEFT CHANNEL

A

B

C

D

E

F

