

AKAI SERVICE MANUAL

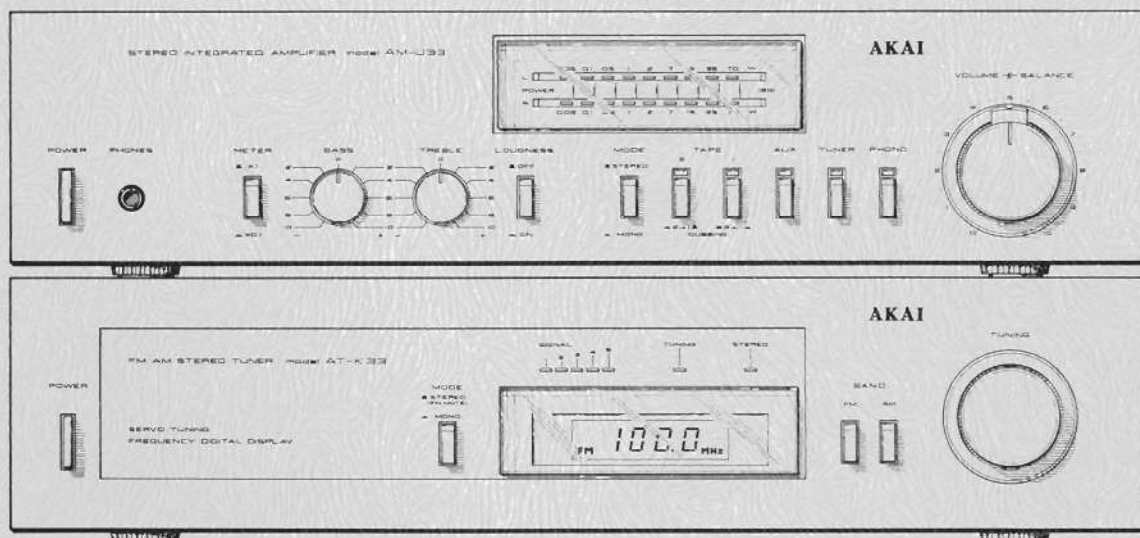

FM AM STEREO TUNER

MODEL **AT-K33/L/J**

STEREO INTEGRATED AMPLIFIER

MODEL **AM-U33/J**

AT-K33/L/J
AM-U33/J

FM AM STEREO TUNER

MODEL AT-K33/L/J

STEREO INTEGRATED AMPLIFIER

MODEL AM-U33/J

THIS MANUAL IS APPLICABLE TO BOTH SILVER AND BLACK PANEL MODEL

TABLE OF CONTENTS

SECTION 1	MODEL AT-K33/L/J SERVICE MANUAL	3
SECTION 2	MODEL AM-U33 SERVICE MANUAL	25
SECTION 3	MODEL AM-U33J SERVICE MANUAL	39
SECTION 4	PARTS LIST	51
SECTION 5	SCHEMATIC DIAGRAM	71



AM-U33



AM-U33J

SECTION 1

FM AM STEREO TUNER

MODEL **AT-K33/L/J**

SERVICE MANUAL

TABLE OF CONTENTS

I.	SPECIFICATIONS	4
	1. MODEL AT-K33/L	4
	2. MODEL AT-K33J	5
II.	DISMANTLING OF UNIT	6
III.	CONTROLS	7
IV.	PRINCIPAL PARTS LOCATION	8
V.	VOLTAGE CONVERSION	9
VI.	TUNER ADJUSTMENTS	10
	1. FM SECTION ADJUSTMENTS	13
	2. AM (AT-K33L: MW) SECTION ADJUSTMENTS	15
	3. LW SECTION ADJUSTMENTS	16
VII.	TUNING CORD THREADING	17
VIII.	CLASSIFICATION OF VARIOUS P.C BOARDS	18
	1. P.C BOARD TITLES AND IDENTIFICATION NUMBERS	18
	2. COMPOSITION OF VARIOUS P.C BOARDS	19

For basic adjustments, measuring methods, and operating principles, refer to GENERAL TECHNICAL MANUAL.

I. SPECIFICATIONS

1. MODEL AT-K33/L

FM TUNER SECTION

TUNING FREQUENCY RANGE	87.5 MHz to 108.0 MHz
USABLE SENSITIVITY (300 ohms)	1.9 μ V
CAPTURE RATIO	1.3 dB
SELECTIVITY (IHF, 400 kHz)	65 dB
IMAGE REJECTION	56 dB
IF REJECTION	90 dB
SPURIOUS REJECTION	85 dB
AM SUPPRESSION	60 dB
SUB CARRIER SUPPRESSION	85 dB
S/N RATIO (MONO/STEREO)	73 dB/65 dB
T.H.D. (MONO/STEREO)	0.10%/0.15%
STEREO SEPARATION (1 kHz)	45 dB
MUTING LEVEL	22 dB

AM TUNER SECTION

MW

TUNING FREQUENCY RANGE	525 kHz to 1,605 kHz
USABLE SENSITIVITY (BAR) (EXT.)	100 μ V/m 10 μ V
SELECTIVITY (HF)	30 dB
IMAGE REJECTION	48 dB
IF REJECTION	33 dB
S/N RATIO	50 dB
T.H.D.	0.3%

LW (AT-K33L only)

TUNING FREQUENCY RANGE	135 kHz to 350 kHz
USABLE SENSITIVITY (BAR) (EXT.)	200 μ V/m 17 μ V
SELECTIVITY (IHF)	30 dB
IMAGE REJECTION	45 dB
IF REJECTION	33 dB
S/N RATIO	50 dB
T.H.D.	0.3%

OUTPUT SECTION

OUTPUT LEVEL FM (100% MOD.) AM (30% MOD.)	775 mV 250 mV
OUTPUT IMPEDANCE	3.3 kohms
POWER REQUIREMENTS	120V, 60 Hz for U.S.A. and Canada 220V, 50 Hz for Europe except UK 240V, 50 Hz for UK and Australia 110V/220V/240V, 50/60 Hz internally switchable for other countries.
POWER CONSUMPTION	10W
DIMENSIONS	440(W) x 98(H) x 290(D) mm (17.3 x 3.9 x 11.4 inches)
WEIGHT	5.35 kg (11.8 lbs)

* For improvement purposes, specifications and design are subject to change without notice.

2. MODEL AT-K33J

FM TUNER SECTION

TUNING FREQUENCY RANGE	76 MHz to 90 MHz
USABLE SENSITIVITY (300 ohms)	1.9 μ V
CAPTURE RATIO	1.3 dB
SELECTIVITY	65 dB
IMAGE REJECTION	60 dB
IF REJECTION	85 dB
AM SUPPRESSION	60 dB
S/N RATIO (MONO/STEREO)	73 dB/65 dB
T.H.D. (MONO/STEREO)	0.08%/0.12%
STEREO SEPARATION (1 kHz)	48 dB
FREQUENCY RESPONSE	20 Hz to 15 kHz, \pm 1 dB
MUTING LEVEL	22 dB

AM TUNER SECTION

TUNING FREQUENCY RANGE	525 kHz to 1,605 kHz
USABLE SENSITIVITY	100 μ V/m
SELECTIVITY	30 dB
IMAGE REJECTION	48 dB
S/N RATIO	55 dB
T.H.D.	0.3%

OUTPUT SECTION

OUTPUT LEVEL	FM (100% MOD.) AM (30% MOD.) CAL. TONE	775 mV 250 mV 388 mV
POWER REQUIREMENT		AC 100V, 50/60 Hz
POWER CONSUMPTION		10W
DIMENSIONS		440(W) \times 105(H) \times 290(D) mm
WEIGHT		5.4 kg

For improvement purposes, specifications and design are subject to change without notice.

II. DISMANTLING OF UNIT

In case of trouble, etc. necessitating dismantling, please dismantle in the order shown in the photographs. Reassemble in reverse order.

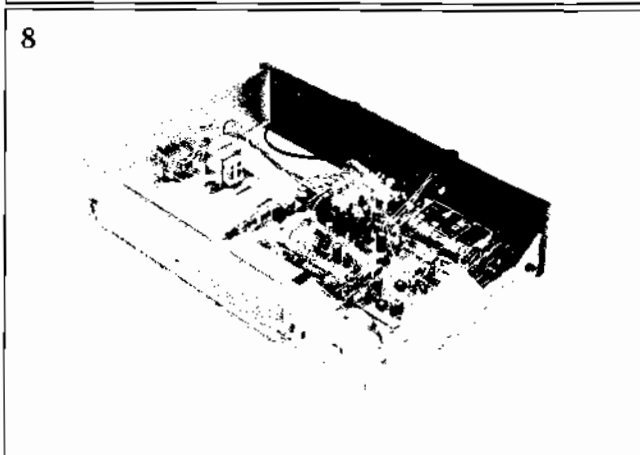
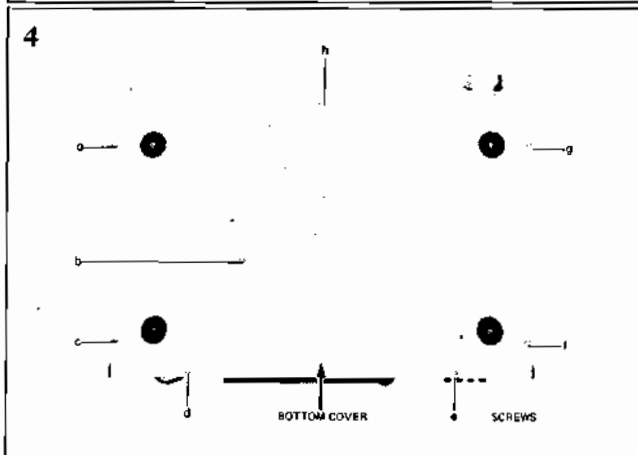
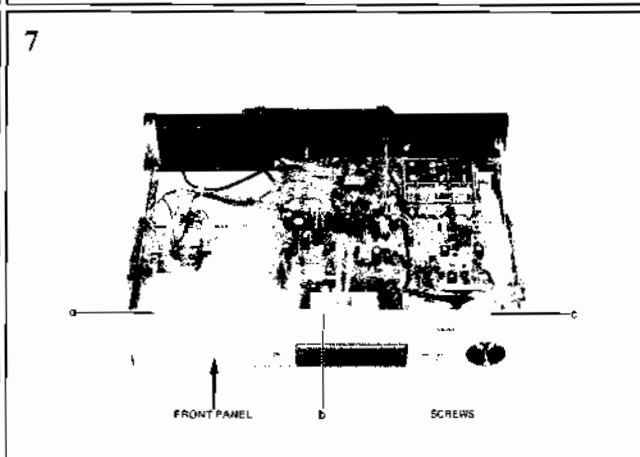
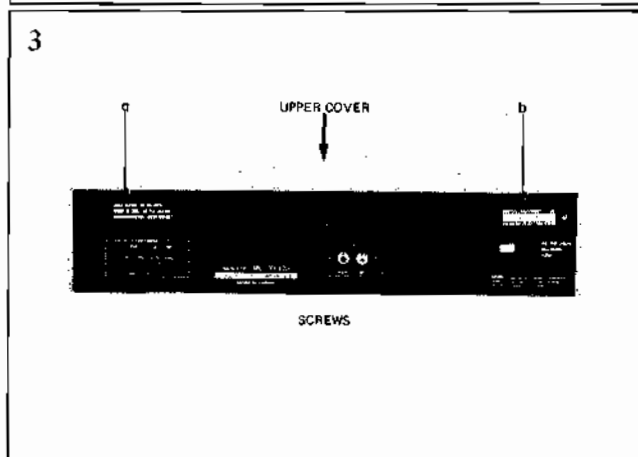
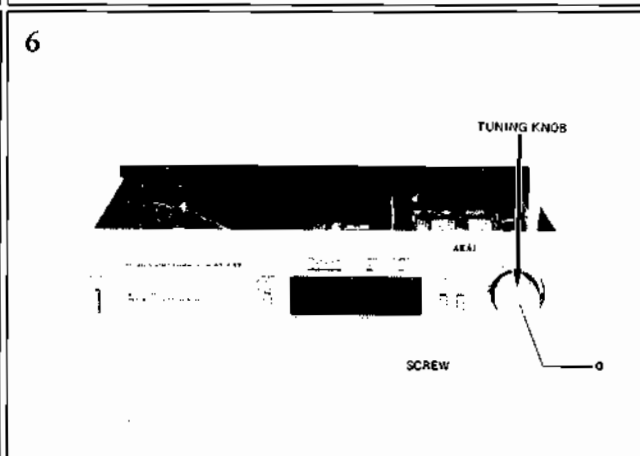
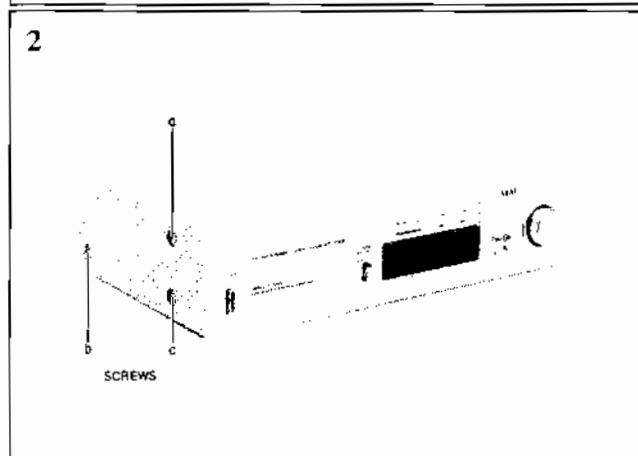
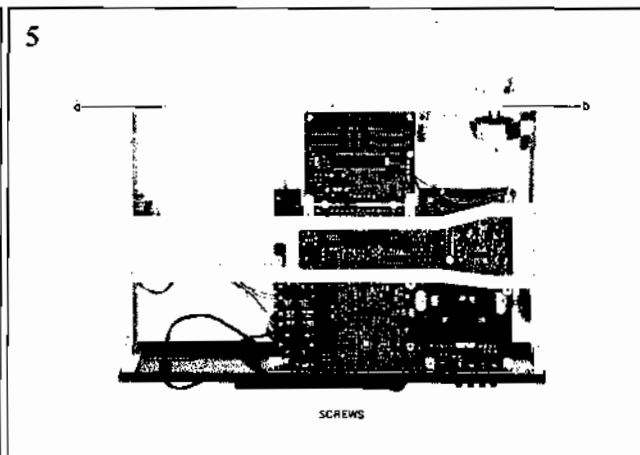
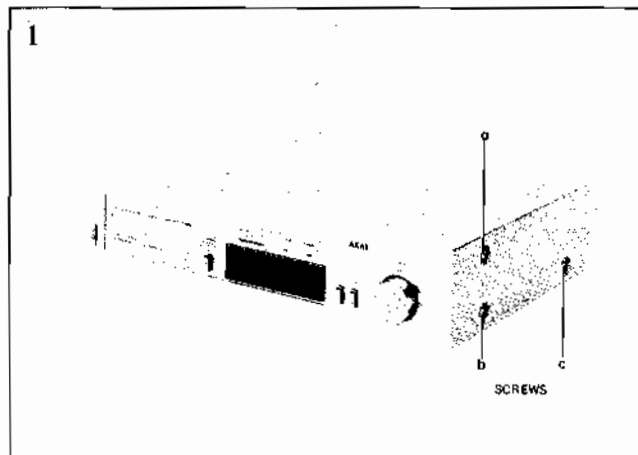

III. CONTROLS

AT-K33/J/L

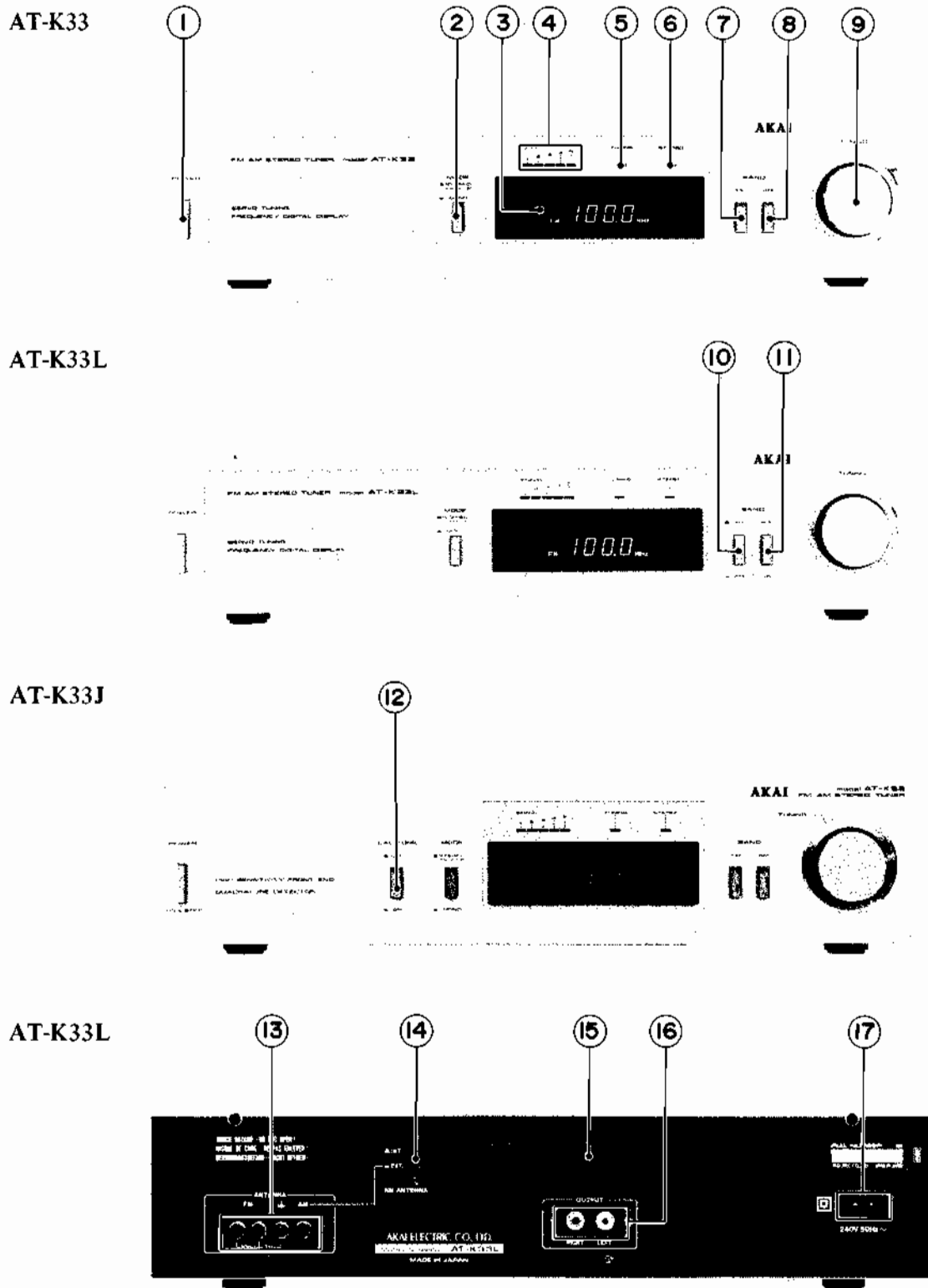

Fig. 1 Controls

- | | |
|---|--|
| <ol style="list-style-type: none"> 1. POWER SWITCH 2. FM MODE SELECTOR 3. DIGITAL LED DISPLAY 4. SIGNAL STRENGTH INDICATORS 5. FM MUTING INDICATOR 6. FM STEREO INDICATOR 7. FM SWITCH (AT-K33/J) 8. AM SWITCH (AT-K33/J) 9. TUNING KNOB | <ol style="list-style-type: none"> 10. AM/FM SELECTOR (AT-K33L Only) 11. MW/LW SELECTOR (AT-K33L Only) 12. CAL TONE SWITCH (AT-K33J Only) 13. FM/AM ANTENNA TERMINALS 14. AM ANTENNA SELECTOR (AT-K33L Only) 15. AM FERRITE BAR ANTENNA 16. OUTPUT JACKS (RIGHT and LEFT) 17. AC INLET (U/T, CSA, AAL, JPN: AC CORD) |
|---|--|

IV. PRINCIPAL PARTS LOCATION

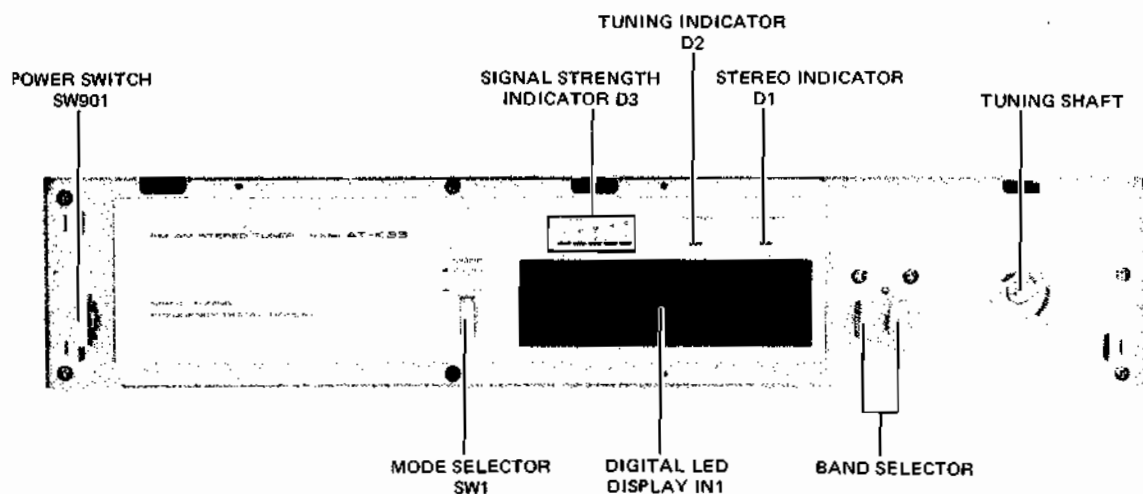

Fig. 2 Front View

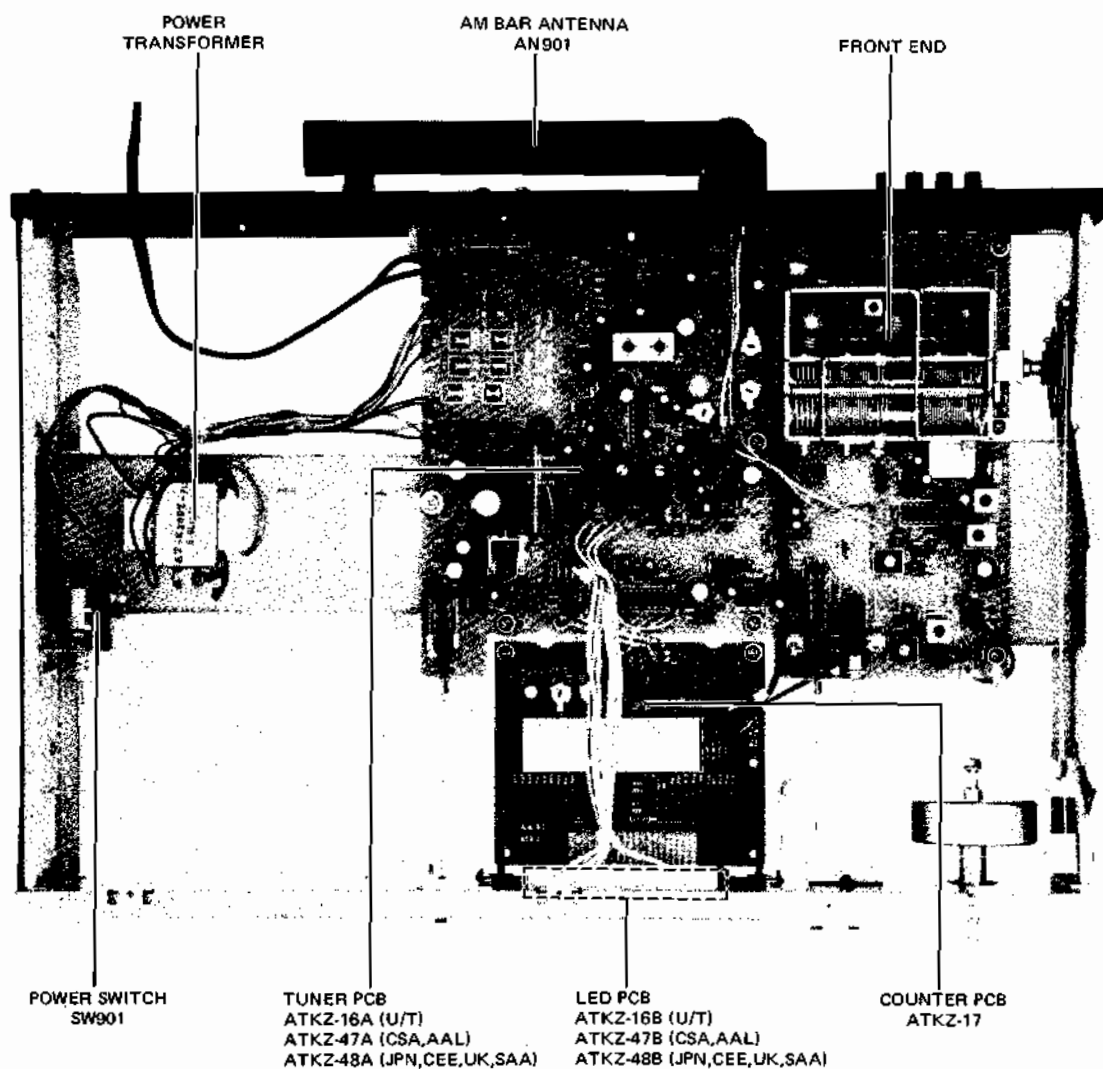

Fig. 3 Top View

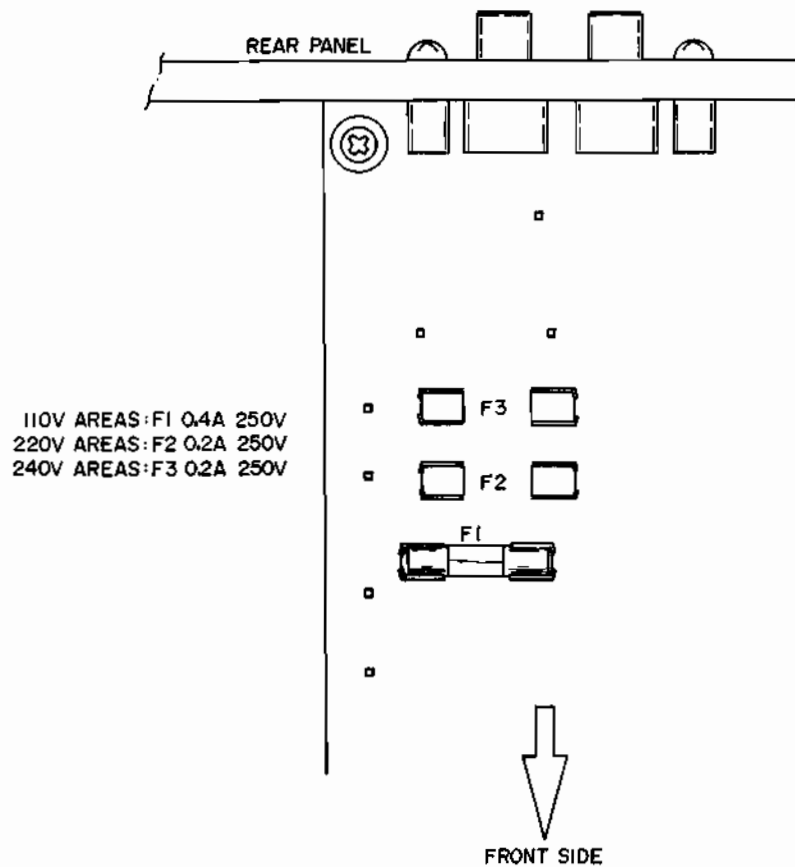

Fig. 4 Voltage Conversion (U/T Model Only)

Model for Canada, U.S.A., Europe, UK and Australia are not equipped with this facility.

Each machine is preset at the factory according to destination but some machines can be set to 110V, 220V or 240V as required.

If voltage change is necessary, this can be accomplished as follows.

- 1) Disconnect AC Power Cord.
- 2) Loosen holding screws and remove upper case.
- 3) Remove existing Line Voltage Fuse and insert required Line Voltage Fuse in proper fuse holder. Follow markings explicitly.

VI. TUNER ADJUSTMENTS

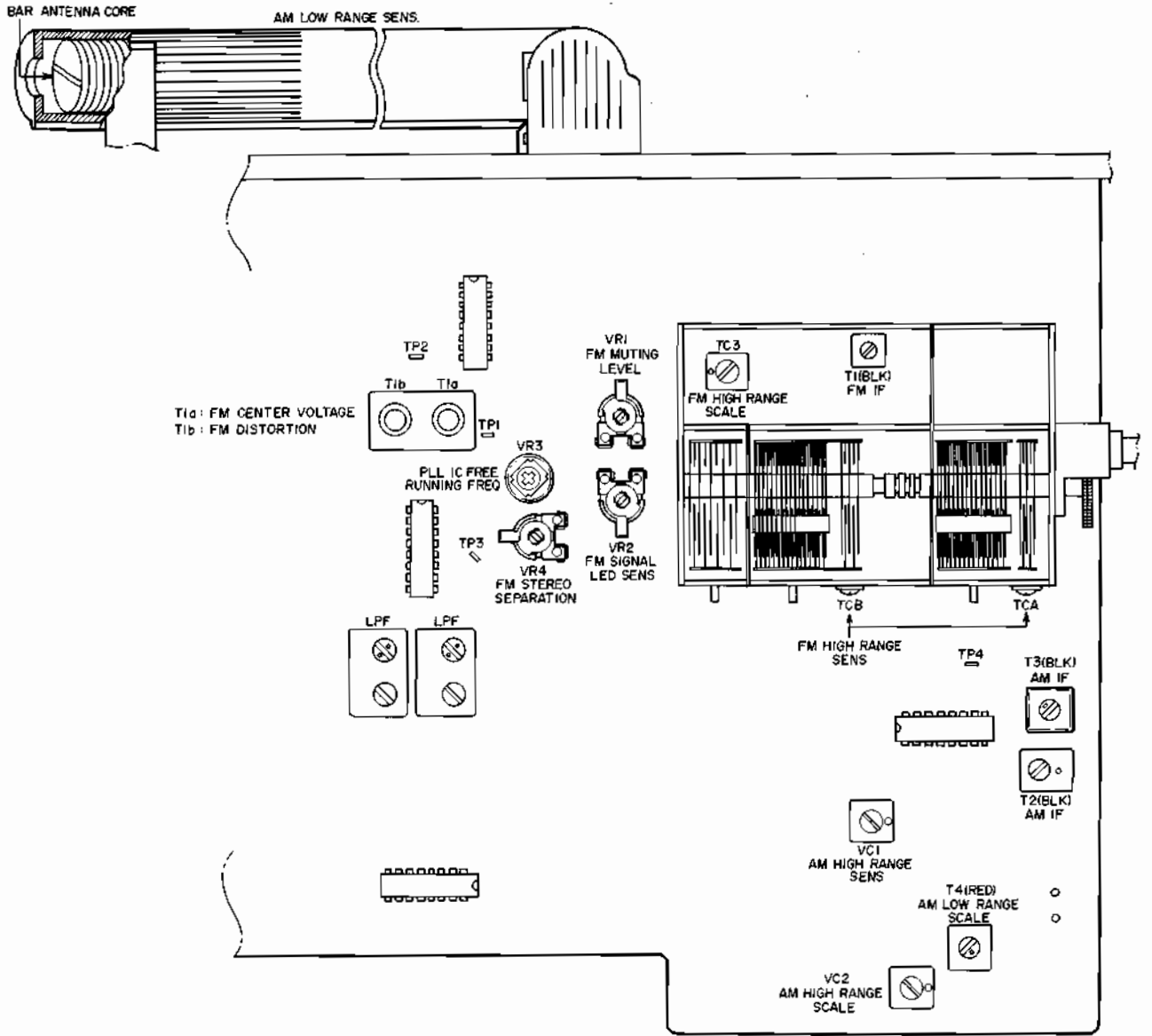

Fig. 5 Tuner P.C Board

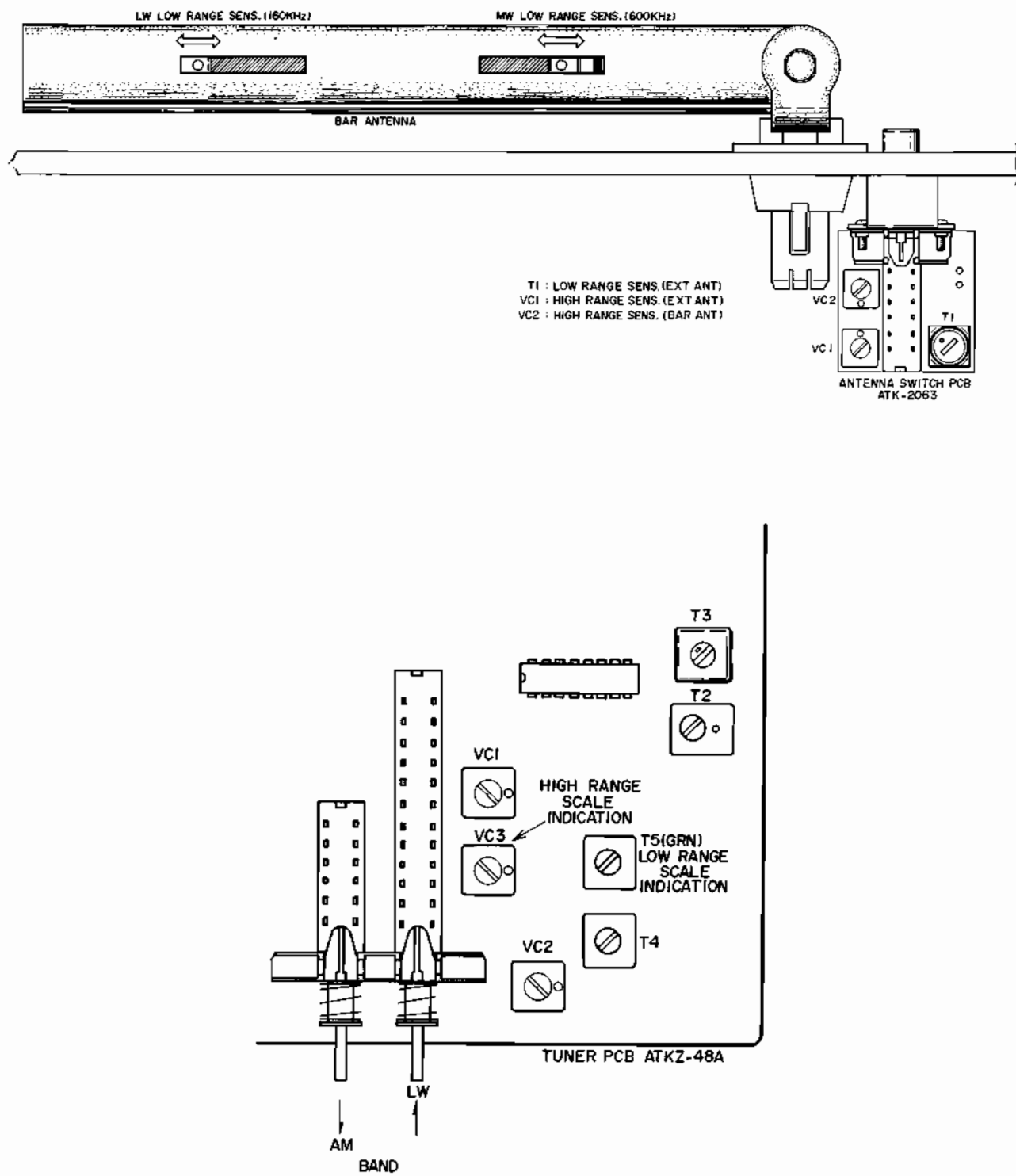

Fig. 6 Tuner P.C Board ATKZ-48A and Antenna Switch P.C Board ATK-2063 (Model AT-K33L)

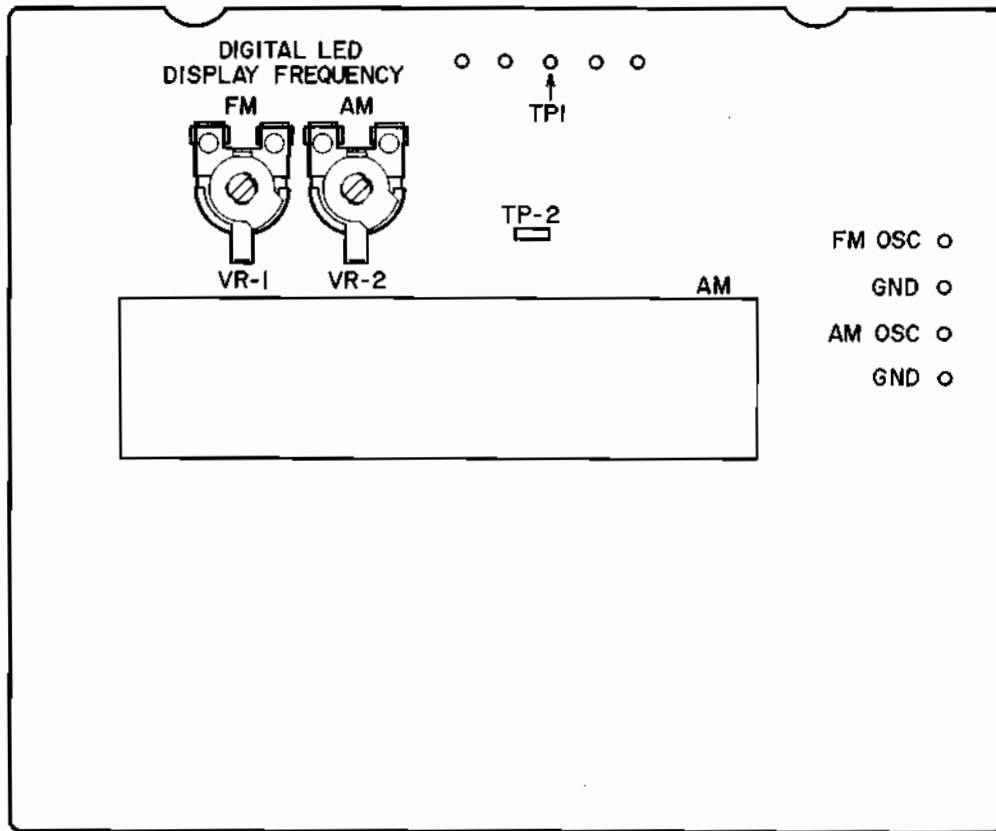

Fig. 7 Counter P.C Board ATKZ-17

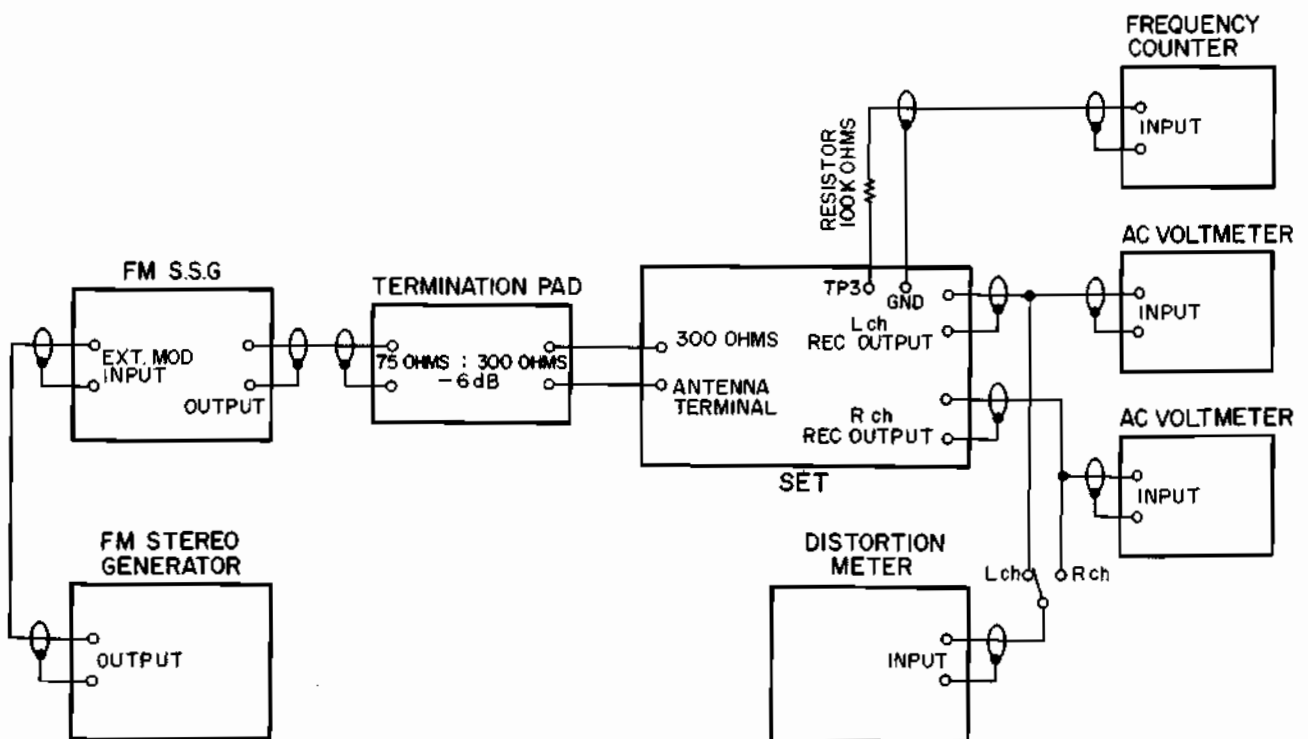

Fig. 8 Instrument Connections

1. FM SECTION ADJUSTMENTS (Refer to Figs. 5, 7, 8)

Unless otherwise specified, use the adjustment points provided on the Tuner P.C Board (Fig. 5).

Step	Adjustment Item	Adjustment Point	Result	Remarks
1	Front-end IF Coil	T1 (BLK) (Front-end)	Maximum Noise Level	BAND switch to FM, and MODE to MONO. Turns only noise without interference from broadcasting.
2	Center Voltage	T1-a	Centered Tuning Meter Indication	Connect a Center Tuning Meter between TP1 and TP2. (See Note 1) Turns only noise without interference from broadcasting.
3	Distortion Factor	T1-b	Distortion Factor: Less than 0.1%	98 MHz (AT-K33J: 83 MHz), 60 dB, 1 kHz (mono 100%) input. Less than 0.1% in both channels.
4				Readjust in Steps 2 and 3.
5	Confirmation of Output Level		0 dBm \pm 3 dB	98 MHz (AT-K33J: 83 MHz), 60 dB, 1 kHz (mono 100%) input.
6	Signal LED Sensitivity	VR2 (30K)		98 MHz (AT-K33J: 83 MHz), 50 dB input. Adjust VR2 to a point where 5th LED of SIGNAL LED lights up. (See Note 2)
7	Digital LED Display Frequency	VR1 (10 KB) Counter P.C Board (Fig. 7)		Apply 98 MHz (AT-K33J: 83 MHz), 60 dB input. Short TP1 to GND on the Counter P.C Board. Adjust VR1 until 3rd numeral display become stable position. (See Note 3)
8	High Range Scale Indication	TC3 (Front-end)		Turn tuning knob fully clockwise. Display 108 MHz (AT-K33J: 90 MHz) by adjusting TC3.
9	High Range Sensitivity	TCA, TCB (Front-end)	Distortion Factor: Less than 3%	MODE switch to MONO. 108 MHz (AT-K33J: 88 MHz), Less than 6 dB, 1 kHz (mono) input.
10	Confirmation of Low Range Sensitivity		Distortion Factor: Less than 3%	88 MHz (AT-K33J: 78 MHz), Less than 6 dB, 1 kHz (mono) input. (See Notes 4 and 5)
11	Muting Level	VR1 (30K)	22 dB \pm 6 dB	MODE switch to STEREO. 98 MHz (AT-K33J: 83 MHz), 22 dB, 1 kHz (mono 100%) input. Adjust VR1 until the output signal is reduced to zero. Vary the SSG output by \pm 6 dB and check muting operation.
12	PLL IC Free Running Frequency	VR3 (4.7K)	19 kHz \pm 50 Hz	Connect a Frequency Counter between TP3 and GND on the Tuner P.C Board. (See Note 6)
13	Stereo Separation (Left \rightarrow Right)	VR4 (500)	More than 45 dB (AT-K33: 48 dB)	98 MHz (AT-K33J: 83 MHz), 60 dB, 1 kHz (stereo 100%) Lch input. Minimum output of Rch.

Step	Adjustment Item	Adjustment Point	Result	Remarks
14	Stereo Separation (Right → Left)	VR4 (500)	More than 45 dB (AT-K33J: 48 dB)	98 MHz (AT-K33J: 83 MHz), 60 dB, 1 kHz (stereo 100%) Rch input. Minimum output of Lch.
15	Confirmation of Stereo Distortion Factor		Distortion Factor: Less than 0.15% (AT-K33J: 0.12%)	100 MHz (AT-K33J: 83 MHz), 60 dB, 1 kHz (stereo 100%) input. If distortion exceeds 0.15% (AT-K33J: 0.12%), first check according to Steps 2, 3, 12, 13 and 14, and then readjust according to Step 1.
16	CAL Tone Level (AT-K33J)	VR1 (3K) CAL Tone PCB	388 mV output	CAL Tone Switch to ON.

- NOTES: 1. For the Center Meter should be used the tuning meter and the like available as a part of the other models.
 2. The 5th LED lights up at 50 dB but when the attenuator is decreased 2 dB it is extinguished.
 3.

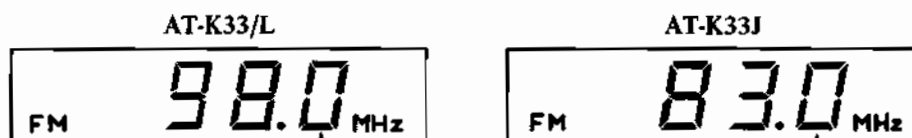

The optimum point of adjustment is when the indicated figure stops flashing.

- When the specified sensitivity of 6 dB cannot be obtained at the two frequency points, 88 (78) MHz and 108 (88) MHz, repeat the adjustment as described in Step 9.
- When the sensitivity distortion factor still does not comply with the data specifications, adjust by turning the Front-end IF Coil core, but not more than 1/2 turn.
- When connecting a Frequency Counter, connect from TP via a 100 kohms resistor. (Refer to Fig. 8)

2. AM (AT-K33L: MW) SECTION ADJUSTMENTS (Refer to Figs. 5, 6, 7, 9)

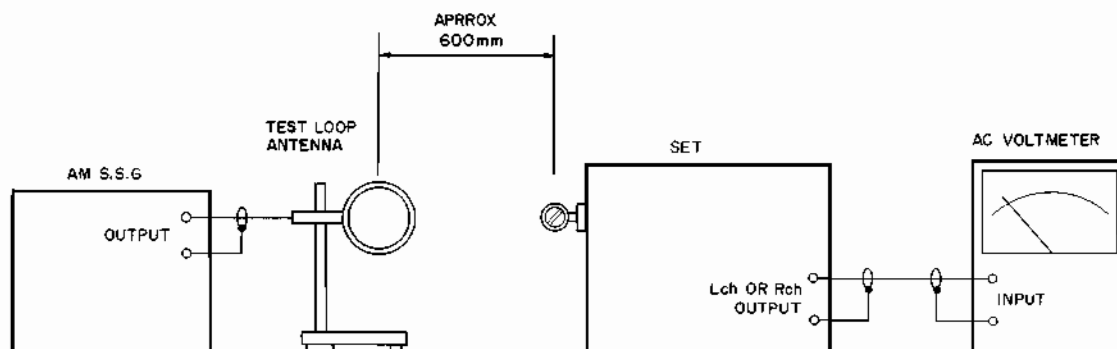

Fig. 9 Instrument Connections for AM (MW) Section Adjustments and Step 3, 4 of LW Section Adjustments

Unless otherwise specified, use the adjustment points provided on the Tuner P.C Board (Fig. 5).

* Model AT-K33L: ANTENNA SELECTOR to INT.

Step	Adjustment Item	Adjustment Point	Result	Remarks
1	Digital LED Display Frequency	VR2 (10KB) Counter P.C Board (Fig. 7)		Apply a 1,000 kHz, 50 dB input. Short TP1 to GND, and TP2 to GND on the Counter P.C Board. Adjust VR2 until 4th numeral display becomes stable position. (See Note 1)
2	AM IF Coil	T2 (BLK) T3 (BLK)	Maximum Output	1,000 kHz, 50 dB, 400 Hz (30%) input.
3	Low Range Scale Indication	T4 (RED)		Turn tuning knob fully counterclockwise. Display 515 kHz by adjusting T4.
4	High Range Scale Indication	VC2		Turn tuning knob fully clockwise. Display 1,650 kHz by adjusting VC2.
5	Low Range Sensitivity	Bar Antenna Core AT-K33/J: Fig. 5 AT-K33L: Fig. 6	Maximum Output Distortion Factor: Less than 10%	600 kHz, 50 dB, 400 Hz (30%) input.
6	High Range Sensitivity	VC1	Maximum Output Distortion Factor: Less than 10%	1,600 kHz, 50 dB, 400 Hz (30%) input.

NOTES: 1.



The optimum point of adjustment is when the indicated figure stops flashing.

2. For best result, repeat Steps 2 through 6 two or three times.

3. LW SECTION ADJUSTMENTS (AT-K33L Only ; Refer to Figs. 6, 9, 10)

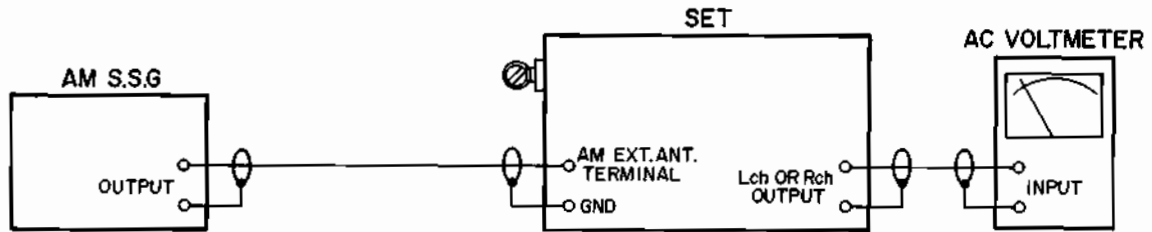

Fig. 10 Instrument Connections
For Steps 5 and 6 of LW Section Adjustments

Unless otherwise specified, use the adjustment points provided on the Tuner P.C Board (Fig. 6).

Step	Adjustment Item	Adjustment Point	Result	Remarks
1	High Range Scale Indication	VC3		Turn tuning knob fully clockwise. Display 350 kHz by adjusting VC3.
2	Low Range Scale Indication	T5 (GRN)		Turn tuning knob fully counterclockwise. Display 135 kHz by adjusting T5.
3	Low Range Sensitivity (Bar Antenna)	Bar Antenna Core (Fig. 6)	Maximum Output Distortion Factor: Less than 10%	ANTENNA SELECTOR to INT. 160 kHz, 50 dB, 400 Hz (30%) input. (Refer to Fig. 9)
4	High Range Sensitivity (Bar Antenna)	VC2 Antenna Switch P.C Board (Fig. 6)	Maximum Output Distortion Factor: Less than 10%	300 kHz, 50 dB, 400 Hz (30%) input. (Refer to Fig. 9)
5	Low Range Sensitivity (EXT. Antenna)	T1 Antenna Switch P.C Board (Fig. 6)	Maximum Output Distortion Factor: Less than 10%	ANTENNA SELECTOR to EXT. 160 kHz, 20 dB, 400 Hz (30%) input. (Refer to Fig. 10)
6	High Range Sensitivity (EXT. Antenna)	VC1 Antenna Switch P.C Board (Fig. 6)	Maximum Output Distortion Factor: Less than 10%	300 kHz, 20 dB, 400 Hz (30%) input. (Refer to Fig. 10)

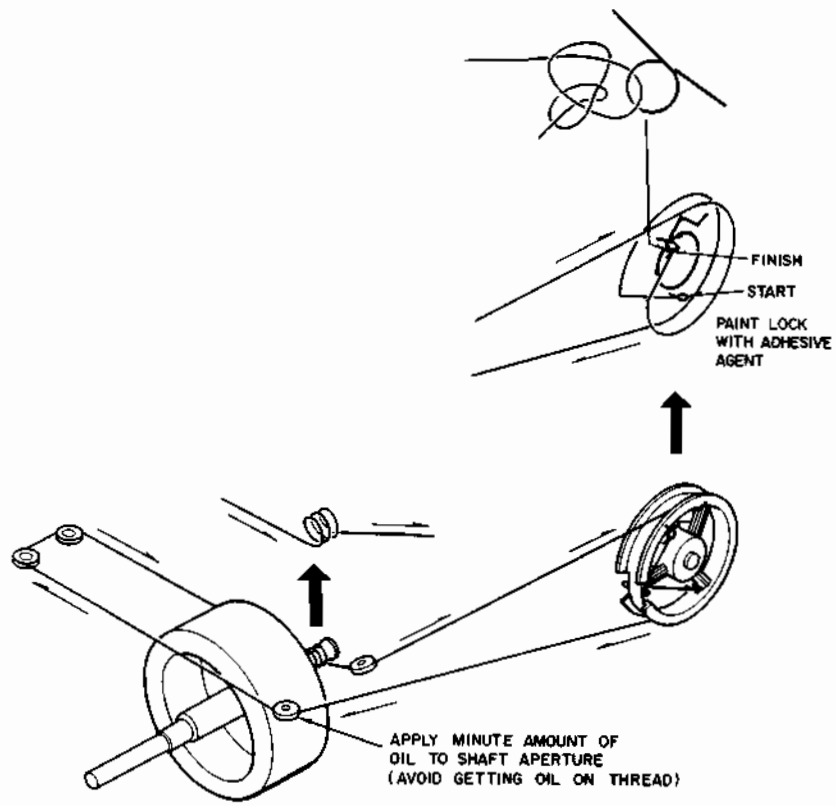

Fig. 11 Tuning Cord Threading

VIII. CLASSIFICATION OF VARIOUS P.C BOARDS

1. P.C BOARD TITLES AND IDENTIFICATION NUMBERS

1) Model AT-K33

P.C Board Title	P.C Board Number	Remarks
Tuner P.C Board	ATKZ-16A	U/T
Tuner P.C Board	ATKZ-47A	CSA, AAL
Tuner P.C Board	ATKZ-48A	CEE, UK, SAA
LED P.C Board	ATKZ-16B	U/T
LED P.C Board	ATKZ-47B	CSA, AAL
LED P.C Board	ATKZ-48B	CEE, UK, SAA
Counter P.C Board	ATKZ-17	
Mute P.C Board	ATKZ-328	

2) Model AT-K33L

P.C Board Title	P.C Board Number	Remarks
Tuner P.C Board	ATKZ-48A	
LED P.C Board	ATKZ-48B	
Counter P.C Board	ATKZ-17	
Mute P.C Board	ATKZ-328	
Antenna Switch P.C Board	ATK-2063	

3) Model AT-K33J

P.C Board Title	P.C Board Number	Remarks
Tuner P.C Board	ATKZ-48A	
LED P.C Board	ATKZ-48B	
Counter P.C Board	ATKZ-17	
Cal Tone P.C Board	ATKZ-327	

2. COMPOSITION OF VARIOUS P.C BOARDS

1) MODEL AT-K33; TUNER P.C BOARD ATKZ-16A (U/T), ATKZ-47A (CSA, AAL), ATKZ-48A (CEE, UK, SAA) and LED P.C BOARD ATKZ-16B (U/T), ATKZ-47B (CSA, AAL), ATKZ-48B (CEE, UK, SAA)

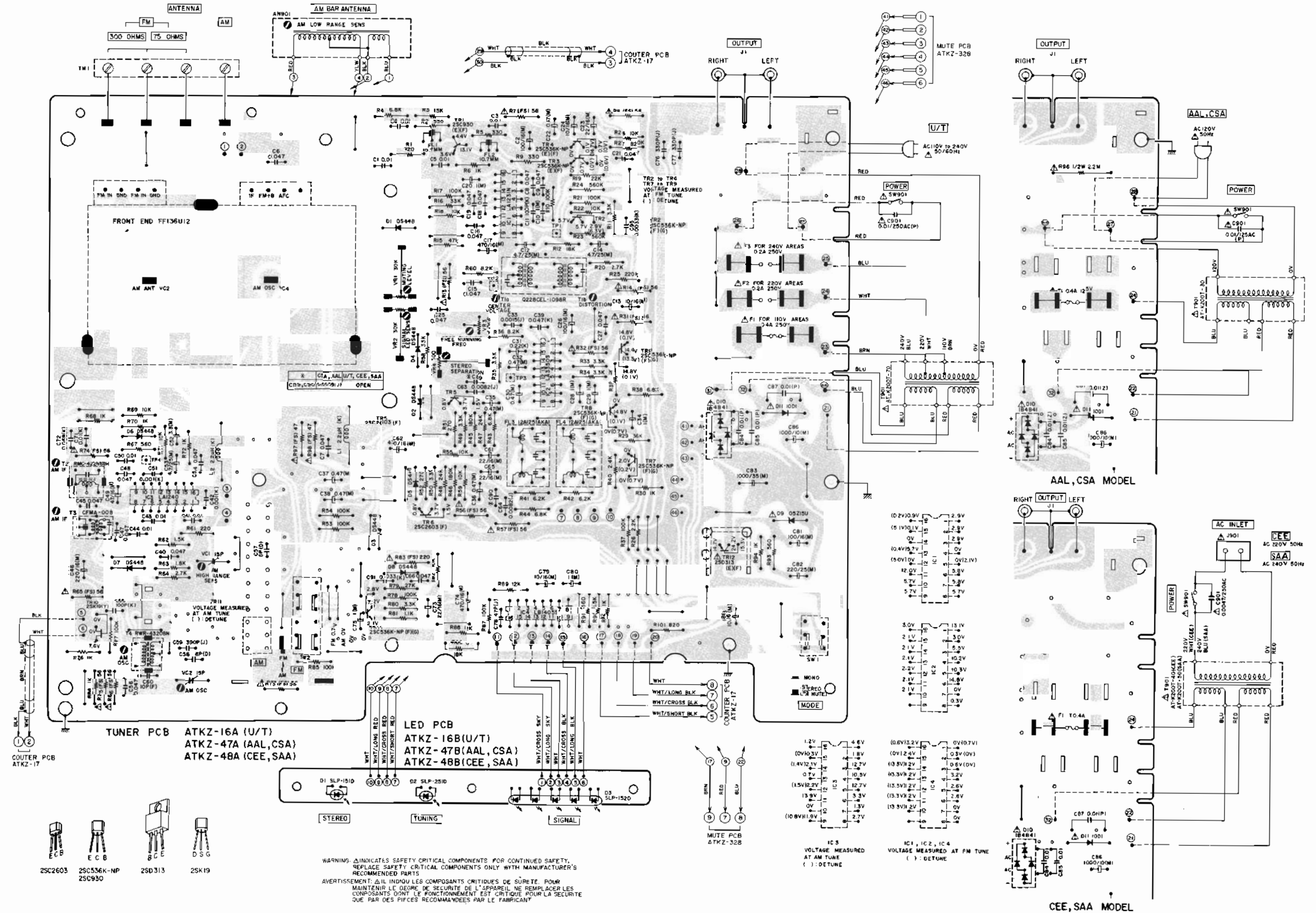

2) MODEL AT-K33L; TUNER P.C BOARD ATKZ-48A and LED P.C BOARD ATKZ-48B

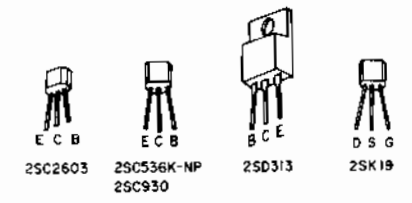
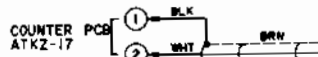
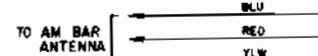
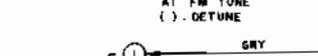
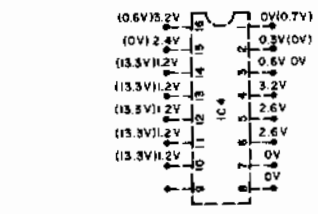
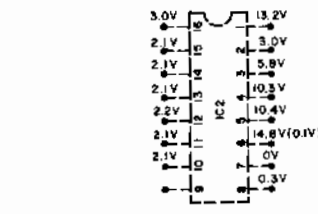
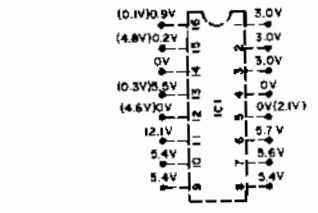
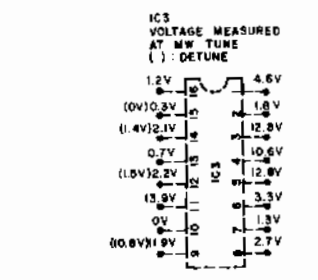
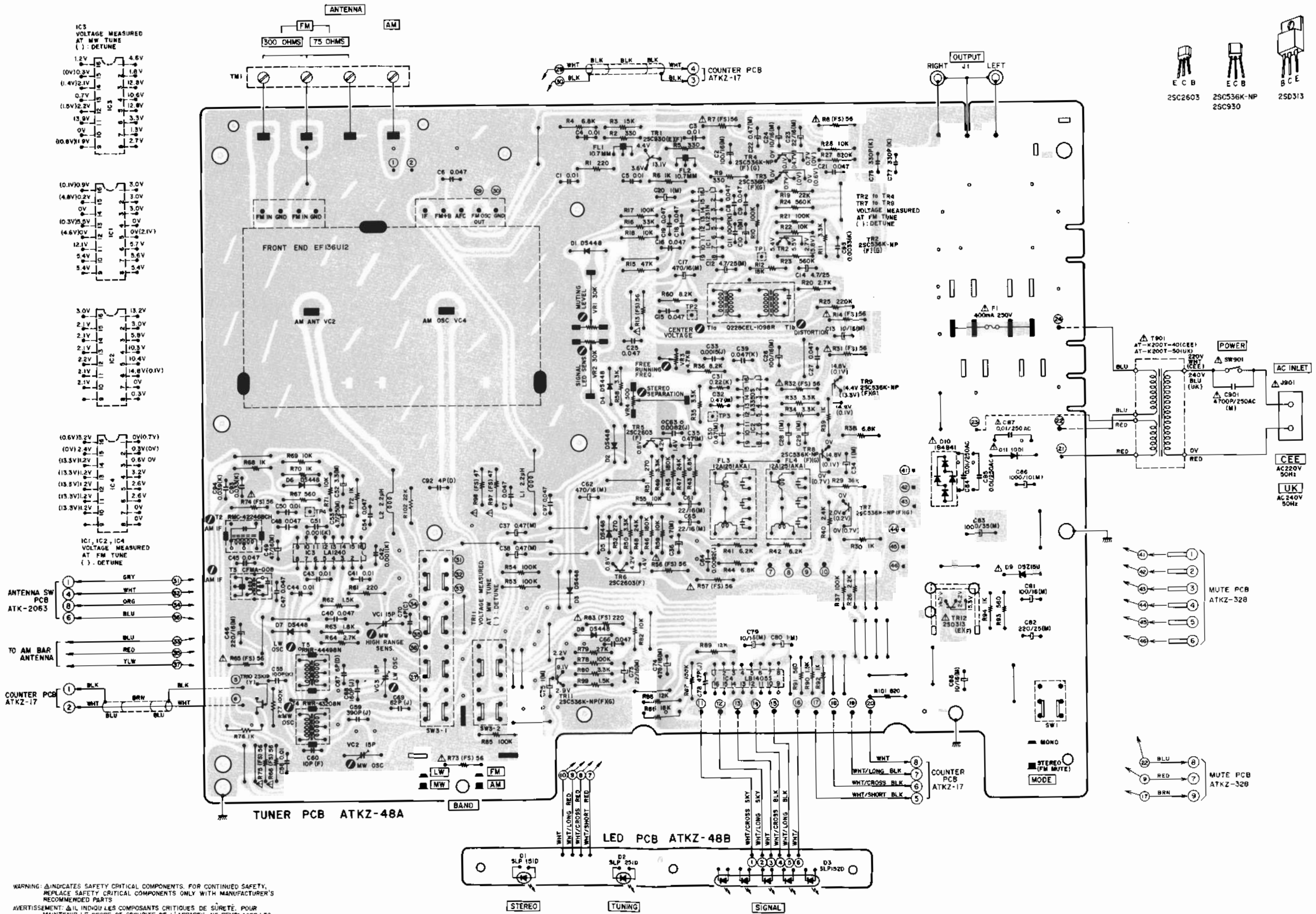

WARNING: Δ INDICATES SAFETY CRITICAL COMPONENTS. FOR CONTINUED SAFETY, REPLACE SAFETY CRITICAL COMPONENTS ONLY WITH MANUFACTURER'S RECOMMENDED PARTS

AVERTISSEMENT: Δ IL INDIQUE LES COMPOSANTS CRITIQUES DE SÛRETÉ. POUR MAINTENIR LE DEGRÉ DE SÛRETÉ DE L'APPAREIL, NE REMPLACER LES COMPOSANTS DONT LE FONCTIONNEMENT EST CRITIQUE POUR LA SÛRETÉ QUE PAR DES PIÈCES RECOMMANDÉES PAR LE FABRICANT

3) MODEL AT-K33J; TUNER P.C BOARD ATKZ-48A and LED P.C BOARD ATKZ-48B

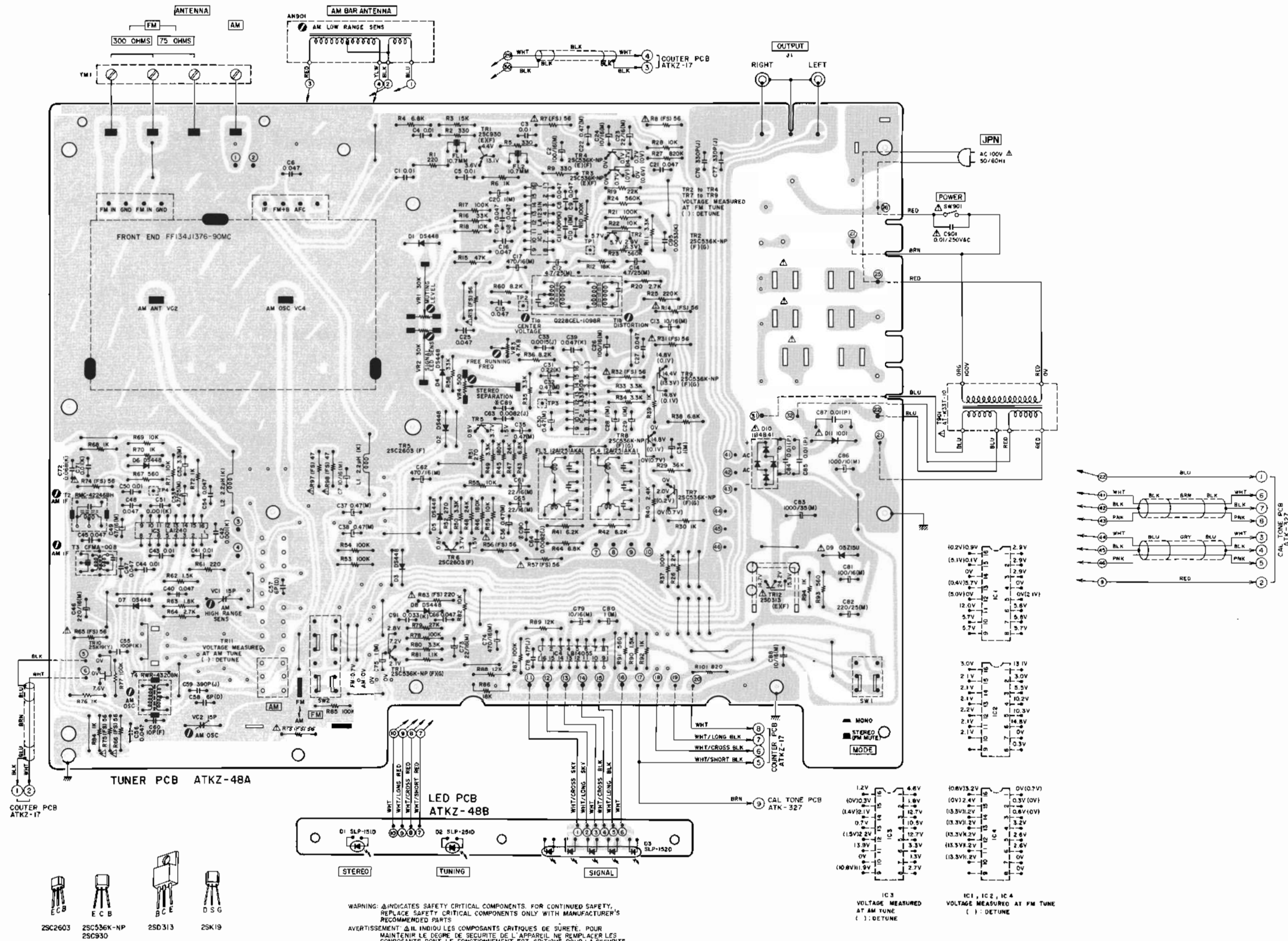

4) COUNTER P.C BOARD ATKZ-17

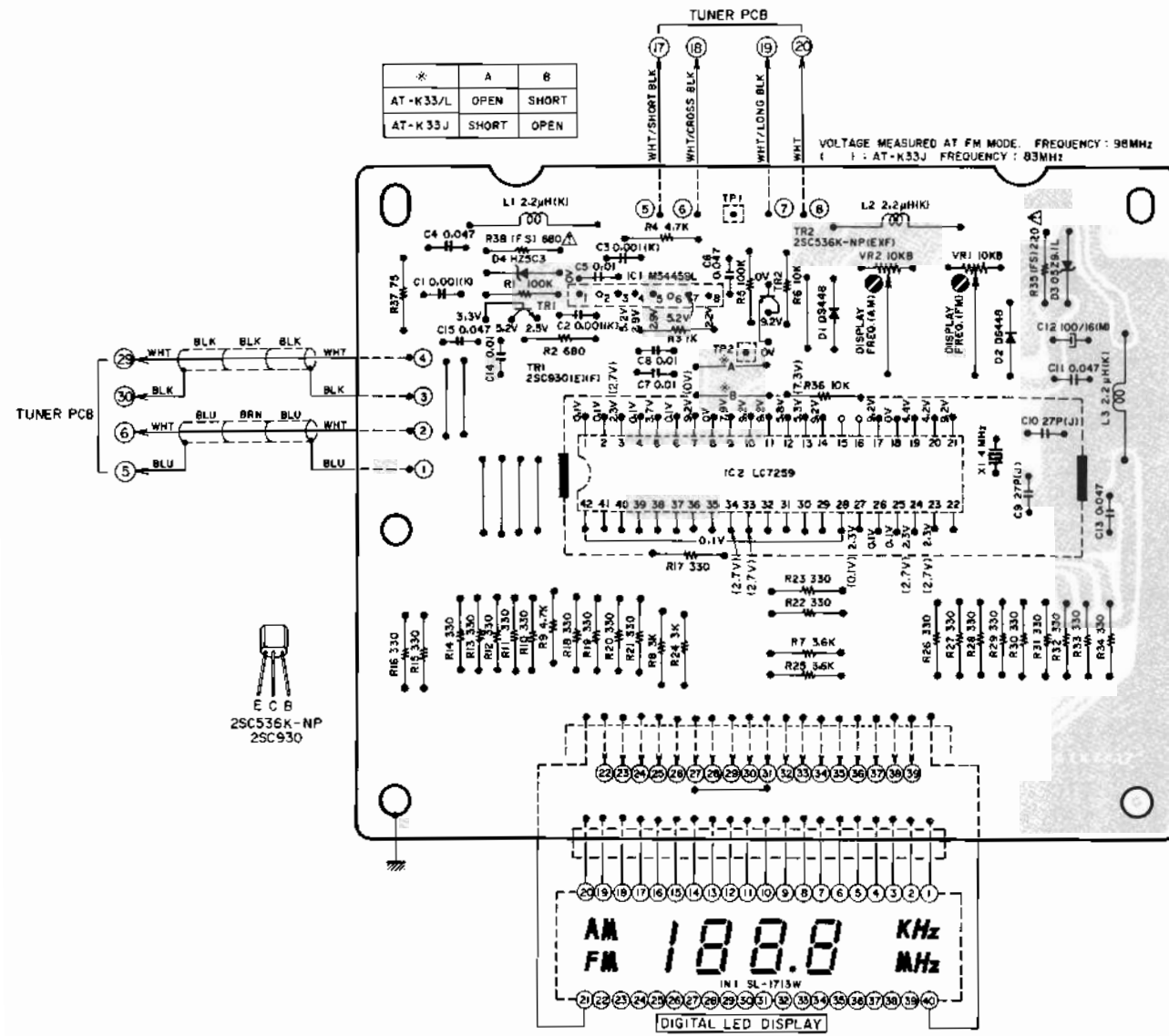

WARNING: Δ INDICATES SAFETY CRITICAL COMPONENTS. FOR CONTINUED SAFETY, REPLACE SAFETY CRITICAL COMPONENTS ONLY WITH MANUFACTURER'S RECOMMENDED PARTS.
 AVERTISSEMENT: Δ IL INDIQU LES COMPOSANTS CRITIQUES DE SÛRETÉ. POUR MAINTENIR LE DEGRÉ DE SÛRETÉ DE L'APPAREIL, NE REMPLACER LES COMPOSANTS DONT LE FONCTIONNEMENT EST CRITIQUE POUR LA SÛRETÉ QUE PAR DES PIÈCES RECOMMANDÉES PAR LE FABRICANT.

5) MUTE P.C BOARD ATKZ-328 (AT-K33/L)

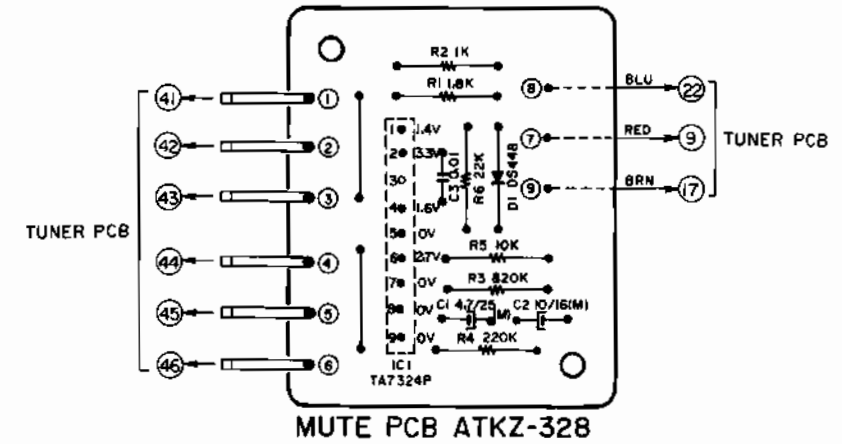

6) CAL TONE P.C BOARD ATKZ-327 (AT-K33J)

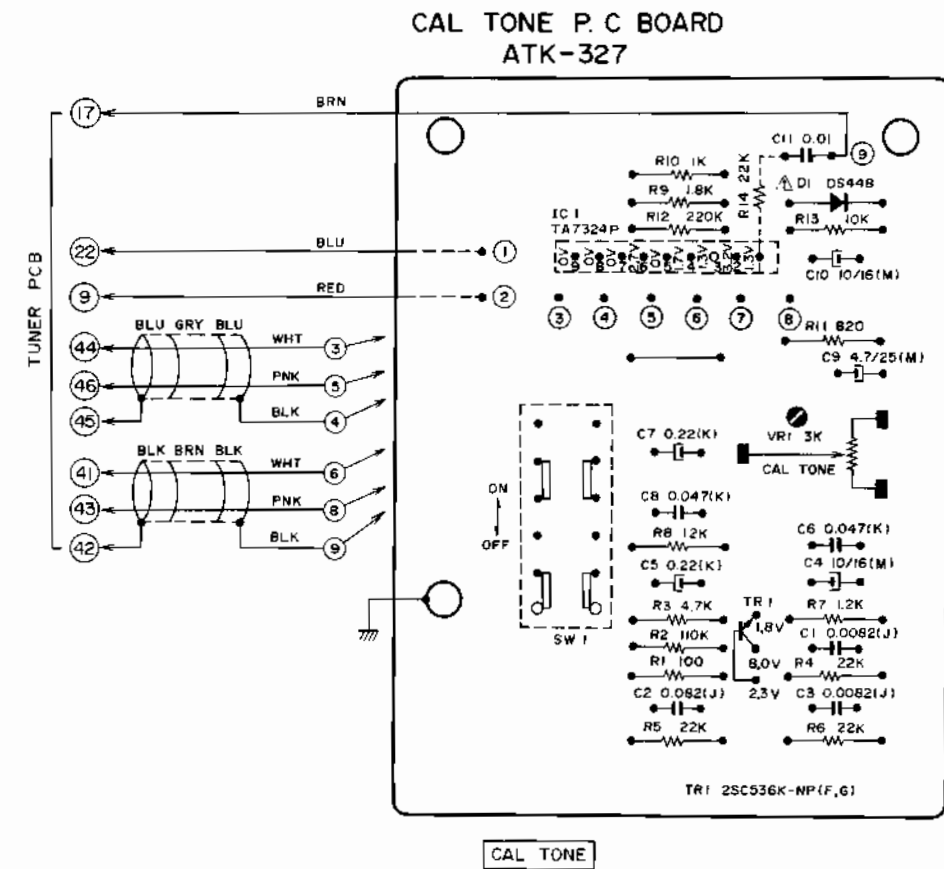

WARNING: Δ INDICATES SAFETY CRITICAL COMPONENTS. FOR CONTINUED SAFETY, REPLACE SAFETY CRITICAL COMPONENTS ONLY WITH MANUFACTURER'S RECOMMENDED PARTS.
 AVERTISSEMENT: Δ IL INDIQU LES COMPOSANTS CRITIQUES DE SÛRETÉ. POUR MAINTENIR LE DEGRÉ DE SÛRETÉ DE L'APPAREIL, NE REMPLACER LES COMPOSANTS DONT LE FONCTIONNEMENT EST CRITIQUE POUR LA SÛRETÉ QUE PAR DES PIÈCES RECOMMANDÉES PAR LE FABRICANT.

7) ANTENNA SWITCH P.C BOARD ATK-2063 (AT-K33L)

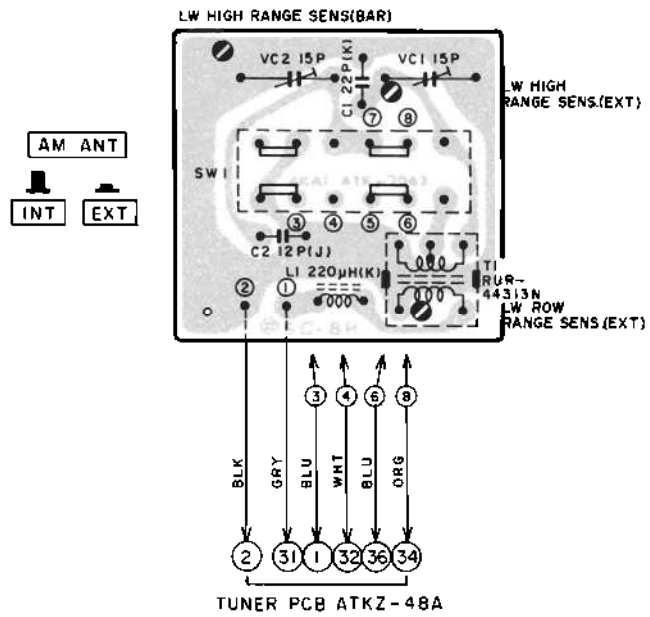
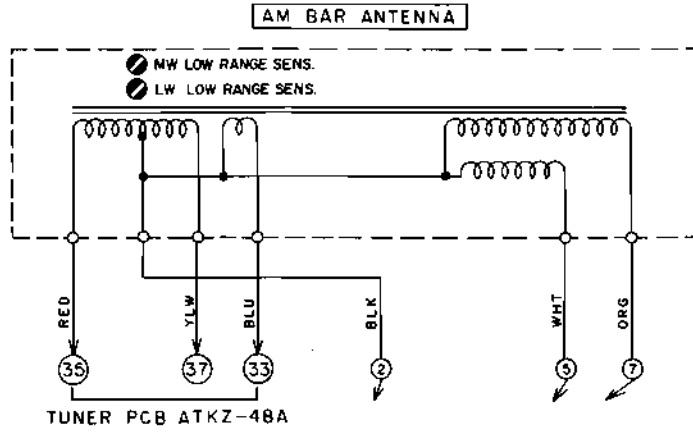

SECTION 2

STEREO INTEGRATED AMPLIFIER

MODEL **AM-U33**

SERVICE MANUAL

TABLE OF CONTENTS

I.	SPECIFICATIONS	26
II.	DISMANTLING OF UNIT	27
III.	CONTROLS	28
IV.	PRINCIPAL PARTS LOCATION	29
V.	VOLTAGE CONVERSION	30
VI.	ADJUSTMENTS	31
	1. POWER METER SENSITIVITY ADJUSTMENT	32
	2. CENTER OFF-SET VOLTAGE ADJUSTMENT	32
VII.	CLASSIFICATION OF VARIOUS P.C BOARDS	32
	1. P.C BOARD TITLES AND IDENTIFICATION NUMBERS	32
	2. COMPOSITION OF VARIOUS P.C BOARDS	33

For basic adjustments, measuring methods, and operating principles, refer to GENERAL TECHNICAL MANUAL.

I. SPECIFICATIONS

POWER AMPLIFIER SECTION

RATED POWER OUTPUT		43 watts per channel, minimum RMS, at 8 ohms from 20 Hz to 20,000 Hz with no more than 0.05% total harmonic distortion.
POWER BANDWIDTH (IHF -3 dB)		5 Hz to 70 kHz/8 ohms (Total harmonic distortion: 0.1%)
SIGNAL TO NOISE RATIO (IHF-A)	PHONO AUX	85 dB 102 dB
RESIDUAL NOISE (IHF-A)		180 μ V/8 ohms
CHANNEL SEPARATION (IHF)		Better than 60 dB at 1 kHz
DAMPING FACTOR		More than 60 (1 kHz, 8 ohms)
OUTPUT	SPEAKER HEADPHONE	4 to 16 ohms 4 to 16 ohms

PREAMPLIFIER SECTION

INPUT SENSITIVITY/IMPEDANCE	PHONO AUX, TUNER, TAPE	3 mV/47 kohms 150 mV/100 kohms
OUTPUT LEVEL/IMPEDANCE	TAPE REC PRE OUT	150 mV 1V/600 ohms
FREQUENCY RESPONSE	PHONO (RIAA DEVIATION) TUNER, AUX, TAPE	20 Hz to 20 kHz \pm 0.3 dB 6 Hz to 100 kHz +0 dB, -3 dB
TONE CONTROL	BASS TREBLE	\pm 8 dB (100 Hz) \pm 8 dB (10 kHz)
LOUDNESS CONTROL (Volume set at -30 dB position)		+10 dB (100 Hz) +6 dB (10 kHz)
PHONO MAX INPUT (1 kHz)		MM: 200 mV
POWER REQUIREMENTS		120V, 60 Hz for U.S.A. and Canada 220V, 50 Hz for Europe except UK 240V, 50 Hz for UK and Australia 110V/220V/240V, 50/60 Hz internally switchable for other countries
AC OUTLET		2 switched, 1 unswitched
POWER CONSUMPTION		220W (U/T), 300W (CEE), 315W (UK, SAA)
DIMENSIONS		440(W) \times 105(H) \times 323(D) mm (17.3 \times 4.1 \times 12.6 inches)
WEIGHT		7.9 kg (17.4 lbs)

* For improvement purposes, specifications and design are subject to change without notice.

II. DISMANTLING OF UNIT

AM-U33

In case of trouble, etc. necessitating dismantling, please dismantle in the order shown in the photographs. Reassemble in reverse order.

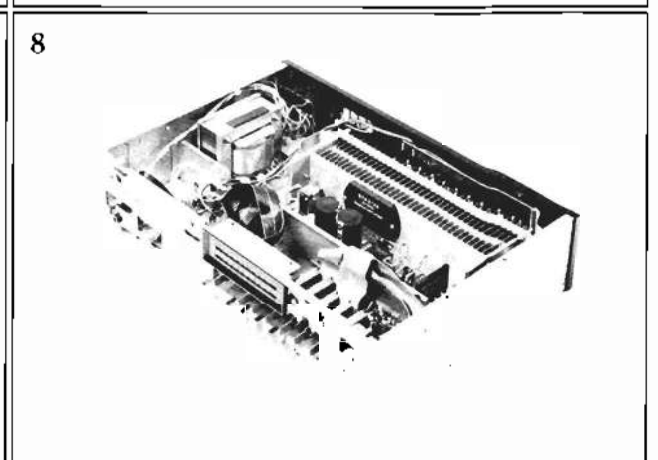
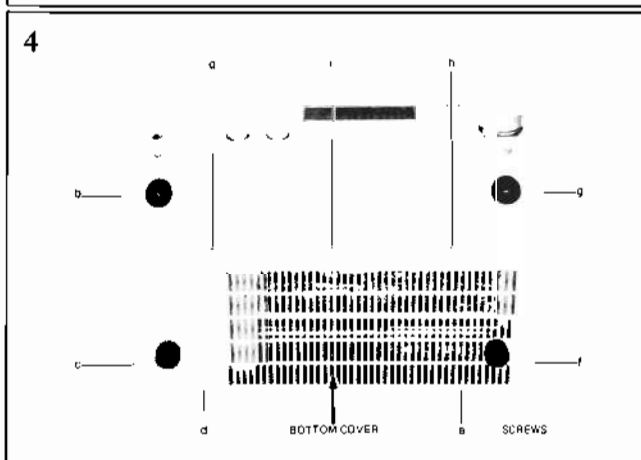
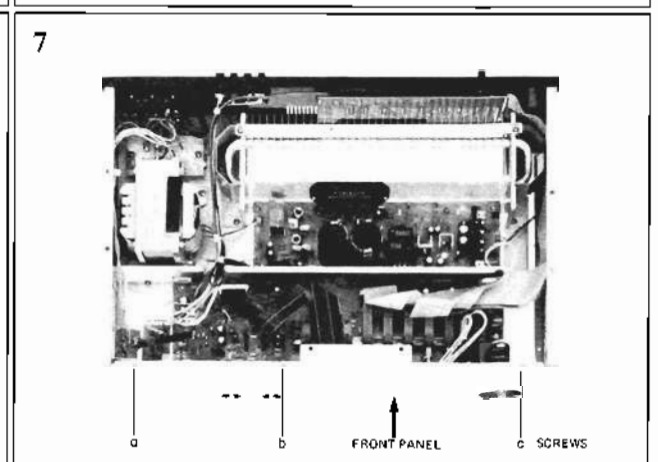
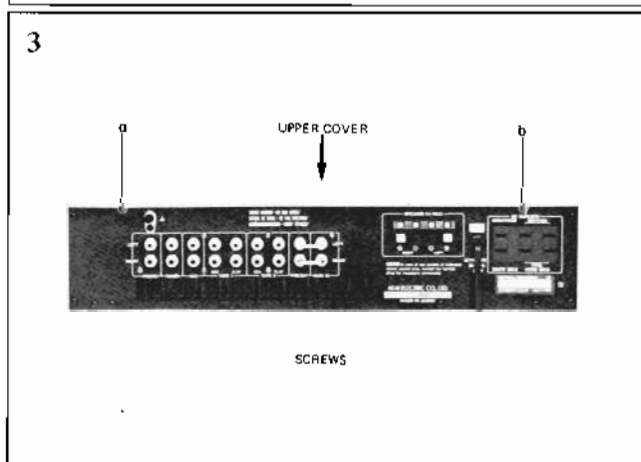
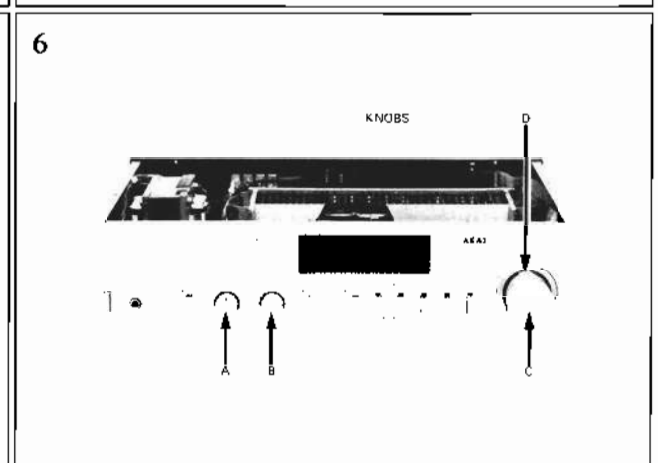
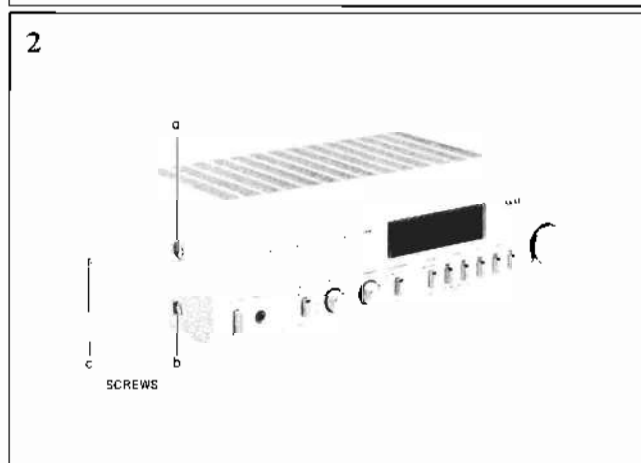
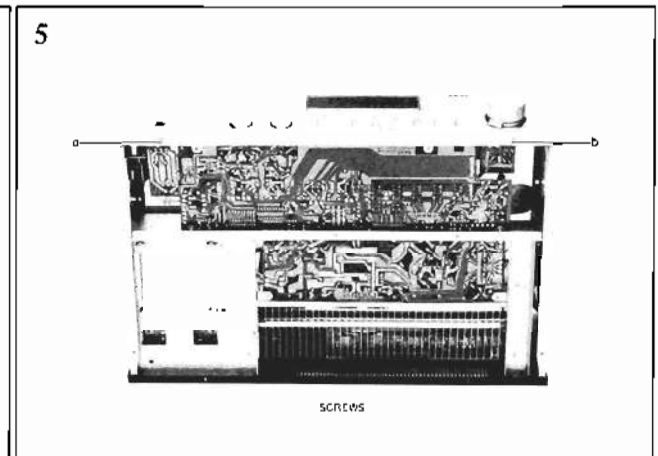
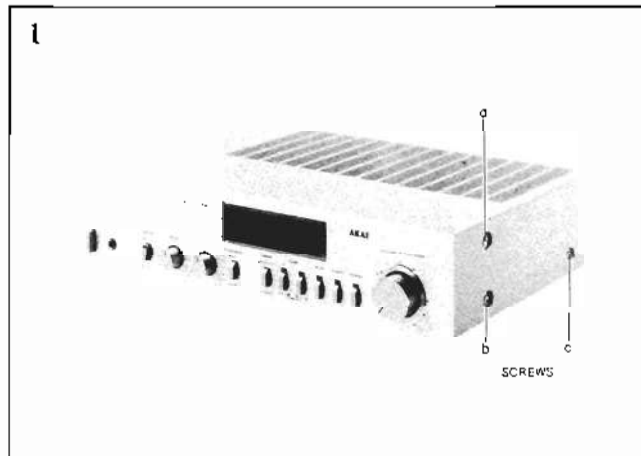

III. CONTROLS

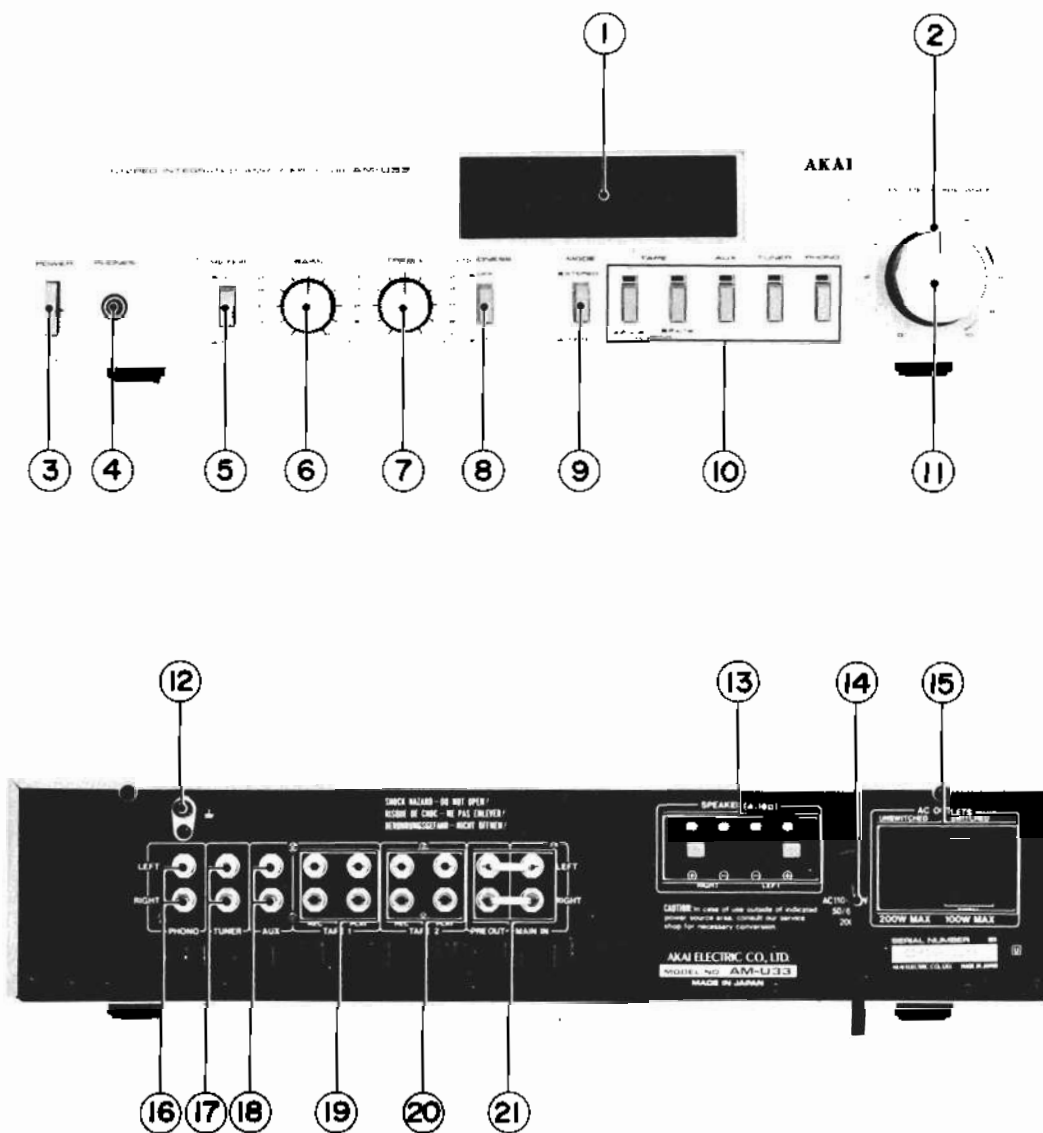



Fig. 1 Controls

- | | |
|--|---|
| 1. LED BAR METERS | 12. GROUND TERMINAL () |
| 2. STEREO BALANCE CONTROL | 13. SPEAKER TERMINALS |
| 3. POWER SWITCH | 14. AC CORD (CEE, UK, SAA: AC INLET) |
| 4. HEADPHONE JACK (PHONES) | 15. AC OUTLETS (U/T, CSA, AAL Only) |
| 5. METER SELECTOR | 16. PHONO JACKS |
| 6. BASS CONTROL | 17. TUNER JACKS |
| 7. TREBLE CONTROL | 18. AUX JACKS |
| 8. LOUDNESS SWITCH | 19. TAPE 1 SYSTEM RECORDING (REC)/PLAY JACKS |
| 9. MODE SELECTOR | 20. TAPE 2 SYSTEM REC/PLAY JACKS |
| 10. INPUT SELECTOR SWITCHES and INDICATORS | 21. PRE OUT and MAIN IN JACKS |
| 11. VOLUME CONTROL | |

IV. PRINCIPAL PARTS LOCATION

AM-U33

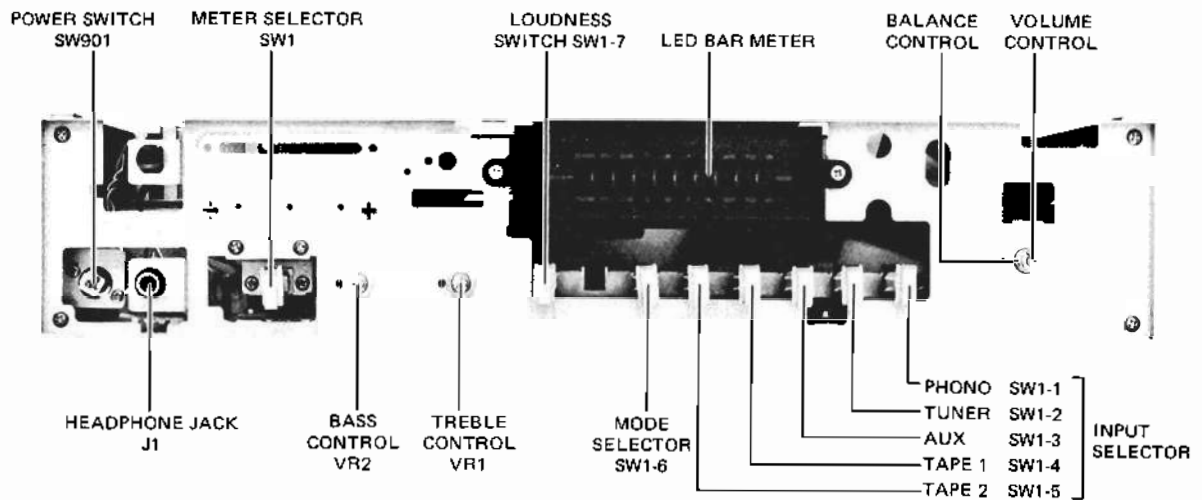

Fig. 2 Front View

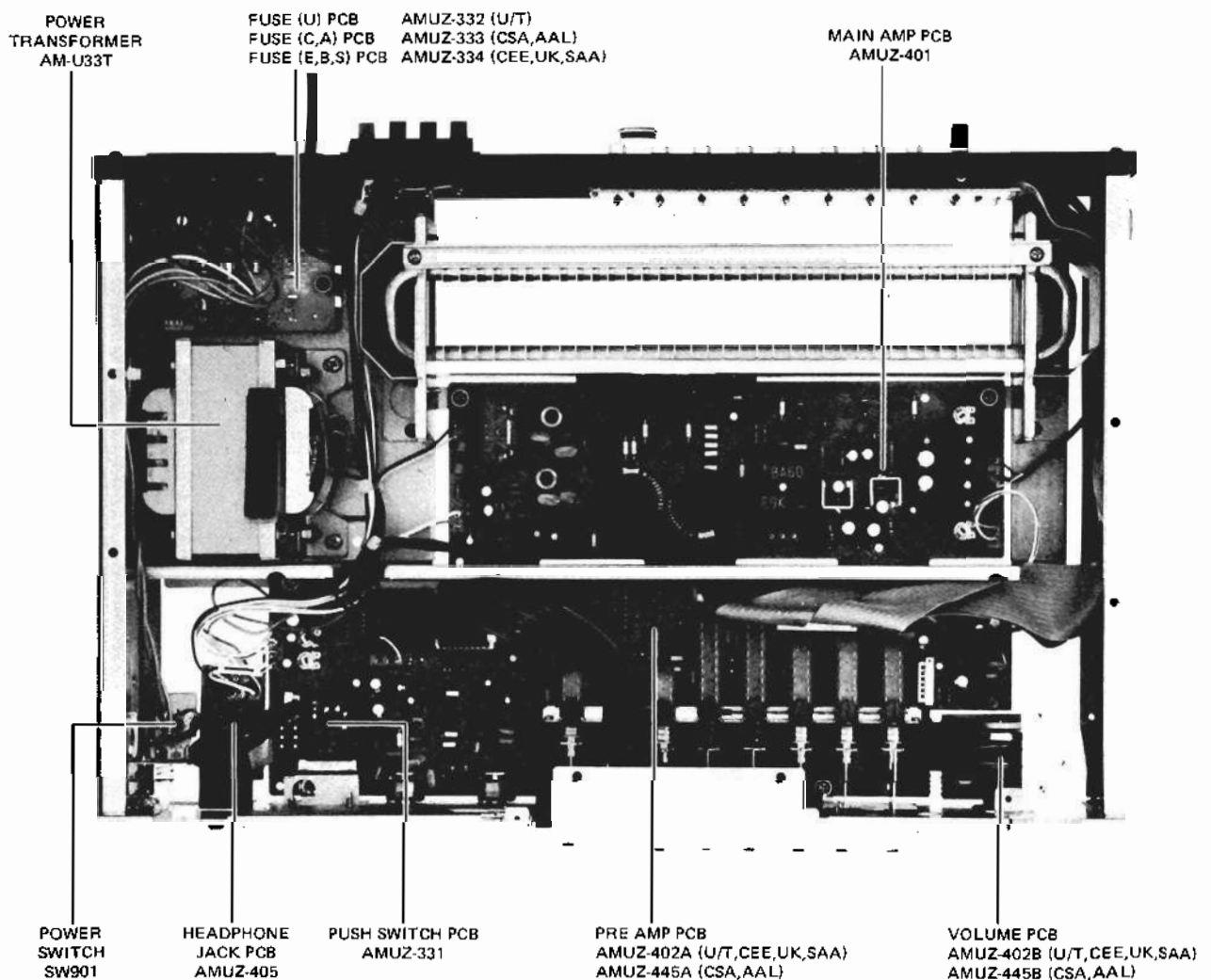

Fig. 3 Top View

V. VOLTAGE CONVERSION

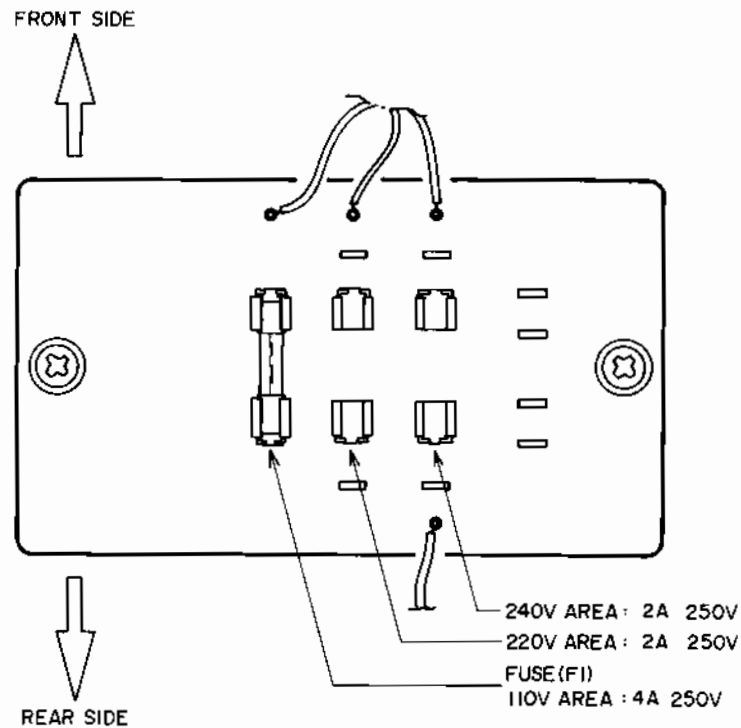

Fig. 4 Voltage Conversion (U/T Model Only)

Models for Canada, U.S.A., Europe, UK, Australia are not equipped with this facility.

Each machine is preset at the factory according to destination but some machines can be set to 110V, 220V or 240V as required.

If voltage change is necessary, this can be accomplished as follows.

- 1) Disconnect AC Power Cord.
- 2) Loosen holding screws and remove upper cover.
- 3) Remove existing Line Voltage Fuse and insert the required Line Voltage Fuse into the proper fuse holder.

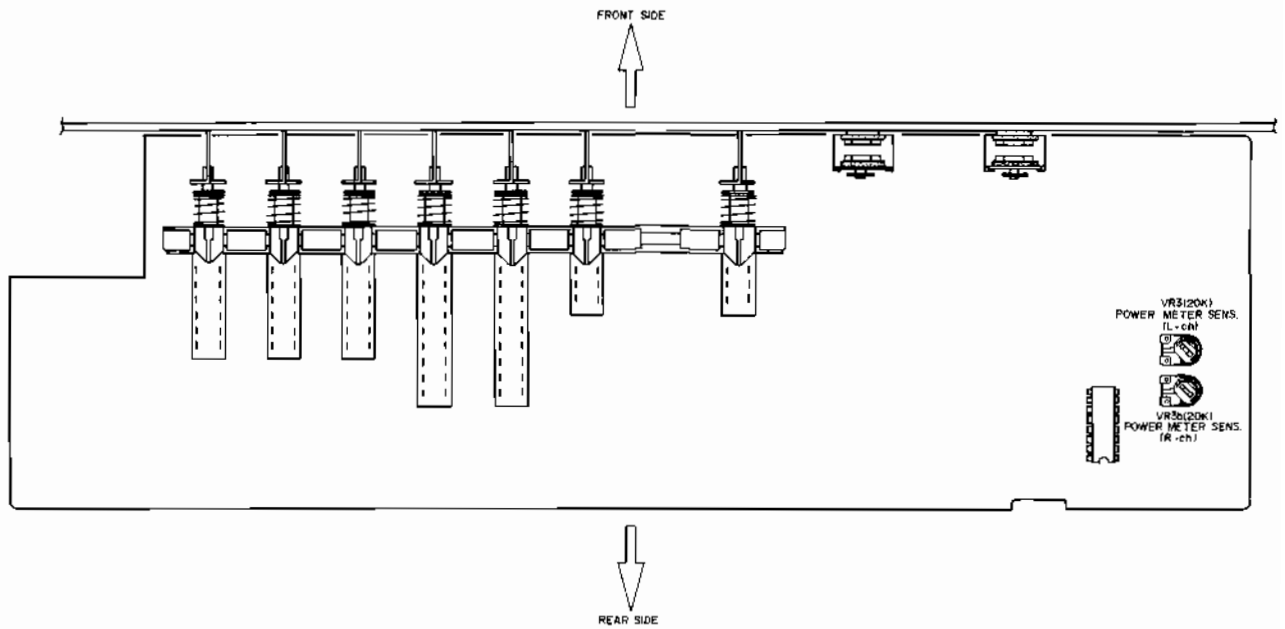

Fig. 5 Pre Amp P.C Board

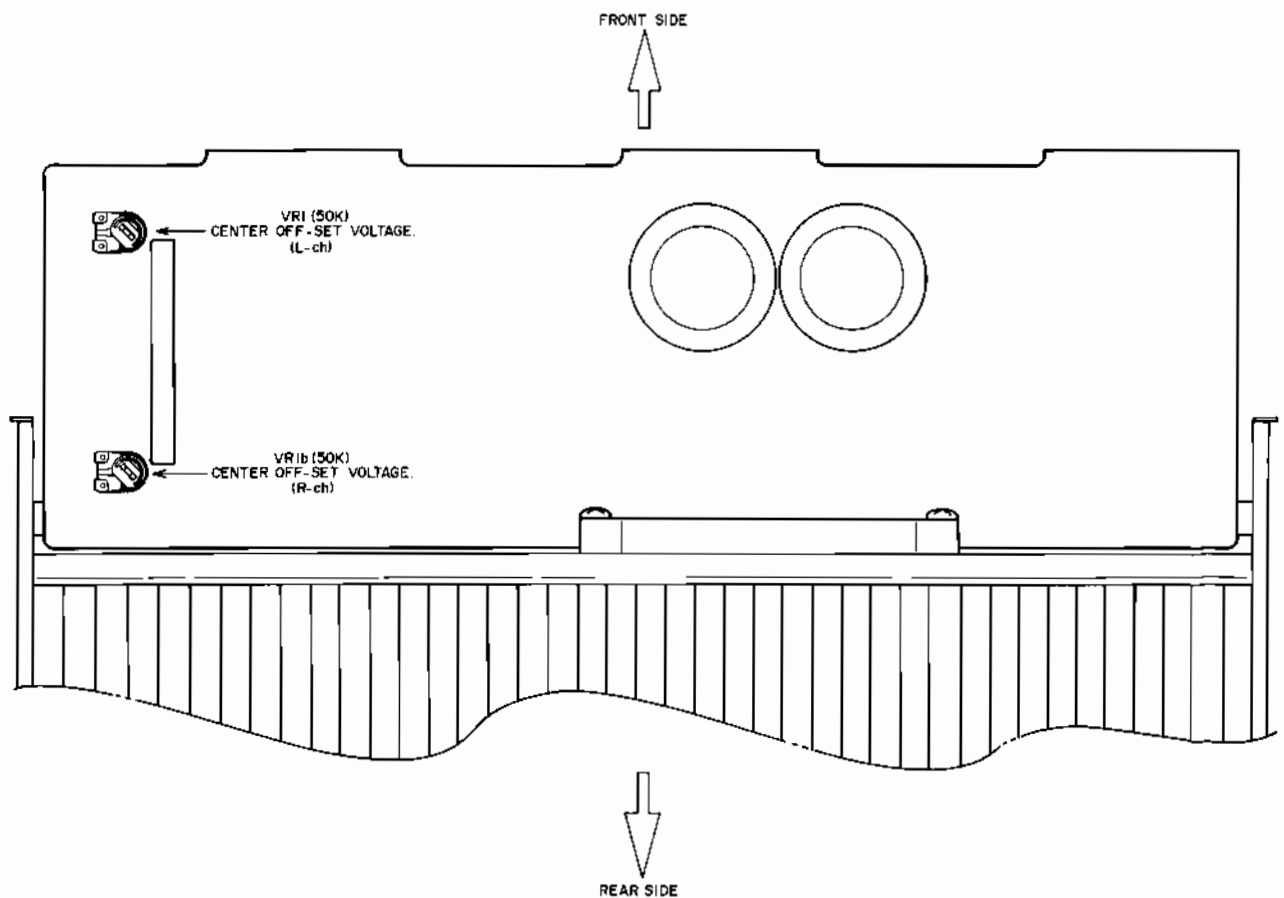

Fig. 6 Main Amp P.C Board

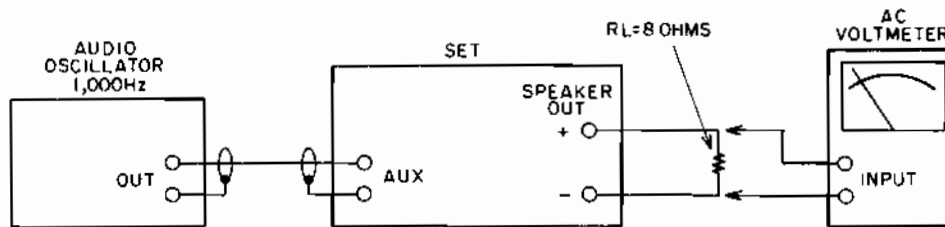

Fig. 7 Instrument Connections for Power Meter Sensitivity Adjustment

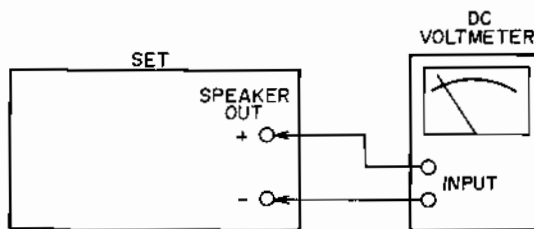

Fig. 8 Instrument Connections for Center Off-set Voltage Adjustment

1. POWER METER SENSITIVITY ADJUSTMENT (Refer to Figs. 5, 7)

Set the Meter Range switch to "x1", and connect the load resistor ($R_L=8$ ohms) to speaker terminals. Then apply a 1 kHz signal to the AUX input terminals, adjusting the input level so as to obtain the rated output voltage level (11V) at both ends of the load resistor.

Adjust VR3 (left channel) and VR3b (right channel) on the Pre Amp P.C Board so that the 7th LED (15 Watts) in the Power Meter light up.

2. CENTER OFF-SET VOLTAGE ADJUSTMENT (Refer to Figs. 6, 8)

Connect the DC Voltmeter or Digital Voltmeter to the speaker terminals. Adjust the VR1 (left channel) and VR1b (right channel) on the Main Amp P.C Board, so that the Voltmeter reads 0 ± 50 mV.

VII. CLASSIFICATION OF VARIOUS P.C BOARDS

1. P.C BOARD TITLES AND IDENTIFICATION NUMBERS

P.C Board Title	P.C Board Number	Remarks
Main Amp P.C Board	AMUZ-401	
Pre Amp P.C Board	AMUZ-402A	U/T, CEE, UK, SAA
Pre Amp P.C Board	AMUZ-445A	CSA, AAL
Volume P.C Board	AMUZ-402B	U/T, CEE, UK, SAA
Volume P.C Board	AMUZ-445B	CSA, AAL
Pin Jack P.C Board	AMUZ-403	
Headphone Jack P.C Board	AMUZ-405	
LED (A) P.C Board	AMUZ-406A	
LED (B) P.C Board	AMUZ-406B	
Push Switch P.C Board	AMUZ-331	
Fuse (U) P.C Board	AMUZ-332	U/T
Fuse (C, A) P.C Board	AMUZ-333	CSA, AAL
Fuse (E, B, S) P.C Board	AMUZ-334	CEE, UK, SAA

2. COMPOSITION OF VARIOUS P.C BOARDS

1) MAIN AMP P.C BOARD AMUZ-401 (2ED)

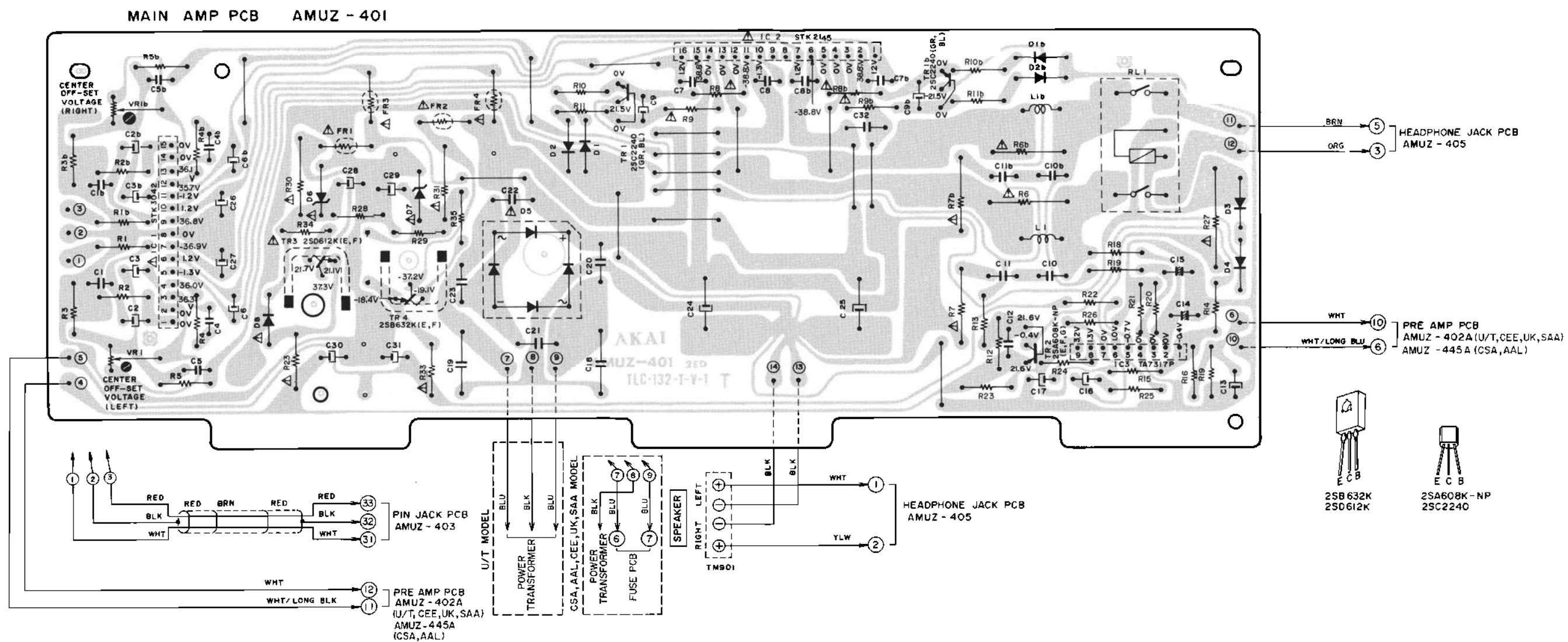

WARNING: Δ INDICATES SAFETY CRITICAL COMPONENTS. FOR CONTINUED SAFETY, REPLACE SAFETY CRITICAL COMPONENTS ONLY WITH MANUFACTURER'S RECOMMENDED PARTS.
 AVERTISSEMENT: Δ IL INDIQUE LES COMPOSANTS CRITIQUES DE SÛRETÉ. POUR MAINTENIR LE DEGRÉ DE SÛRETÉ DE L'APPAREIL, NE REMPLACER LES COMPOSANTS DONT LE FONCTIONNEMENT EST CRITIQUE POUR LA SÛRETÉ QUE PAR DES PIÈCES RECOMMANDÉES PAR LE FABRICANT.

2) PRE AMP P.C BOARD AMUZ-402A 2ED (U/T, CEE, UK, SAA), AMUZ-445A 2ED (CSA, AAL), VOLUME P.C BOARD AMUZ-402B (U/T, CEE, UK, SAA), AMUZ-445B (CSA, AAL), HEADPHONE JACK P.C BOARD AMUZ-405, LED (A) P.C BOARD AMUZ-406A, LED (B) P.C BOARD AMUZ-406B and PUSH SWITCH P.C BOARD AMUZ-331

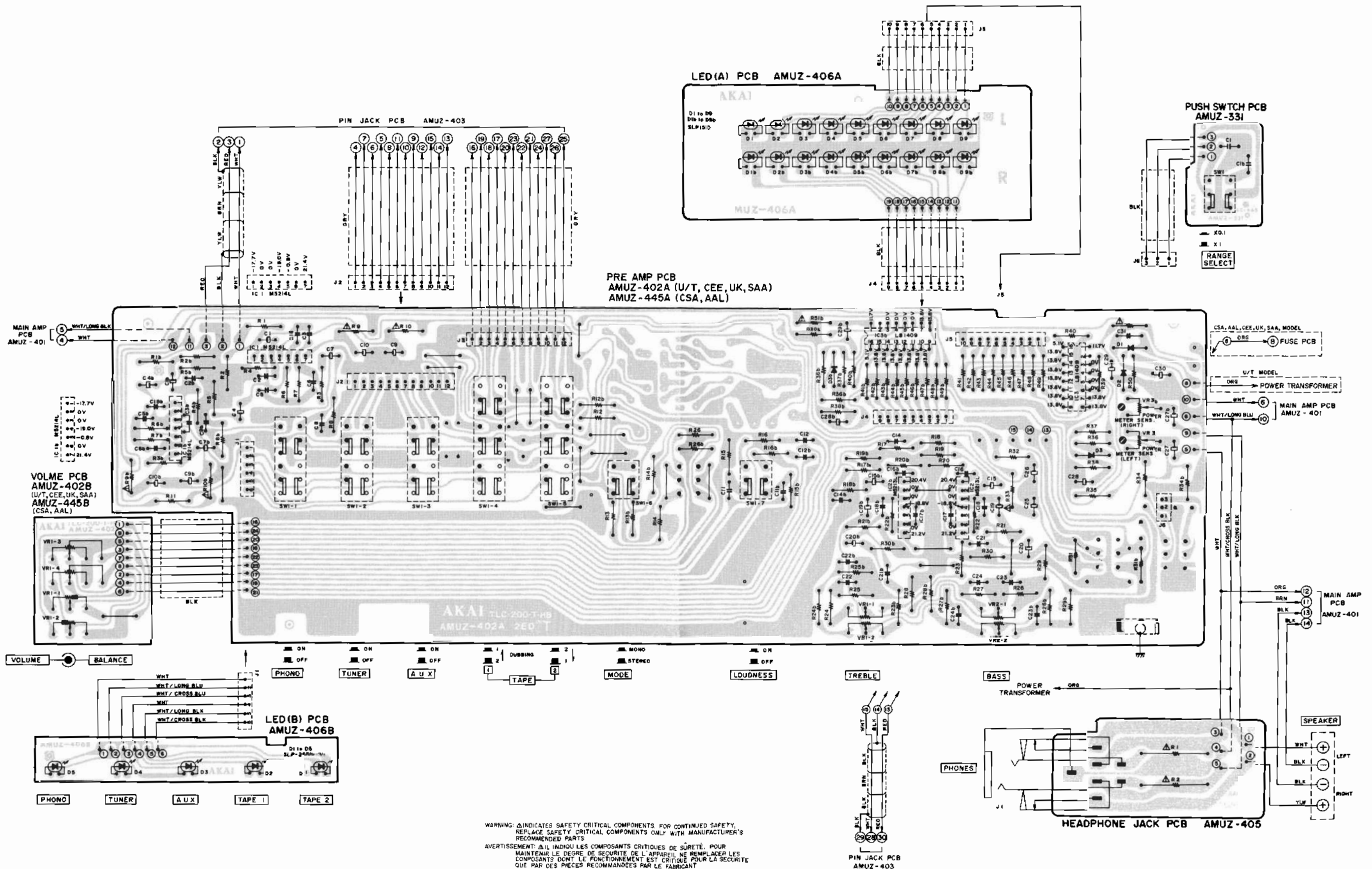

WARNING: Δ INDICATES SAFETY CRITICAL COMPONENTS. FOR CONTINUED SAFETY, REPLACE SAFETY CRITICAL COMPONENTS ONLY WITH MANUFACTURER'S RECOMMENDED PARTS.
 AVERTISSEMENT: Δ IL INDIQUE LES COMPOSANTS CRITIQUES DE SÛRETÉ. POUR MAINTENIR LE DEGRÉ DE SÛRETÉ DE L'APPAREIL, NE REMPLACER LES COMPOSANTS OÙ LE FONCTIONNEMENT EST CRITIQUE POUR LA SÛRETÉ QUE PAR DES PIÈCES RECOMMANDÉES PAR LE FABRICANT.

3) PIN JACK P.C BOARD AMUZ-403

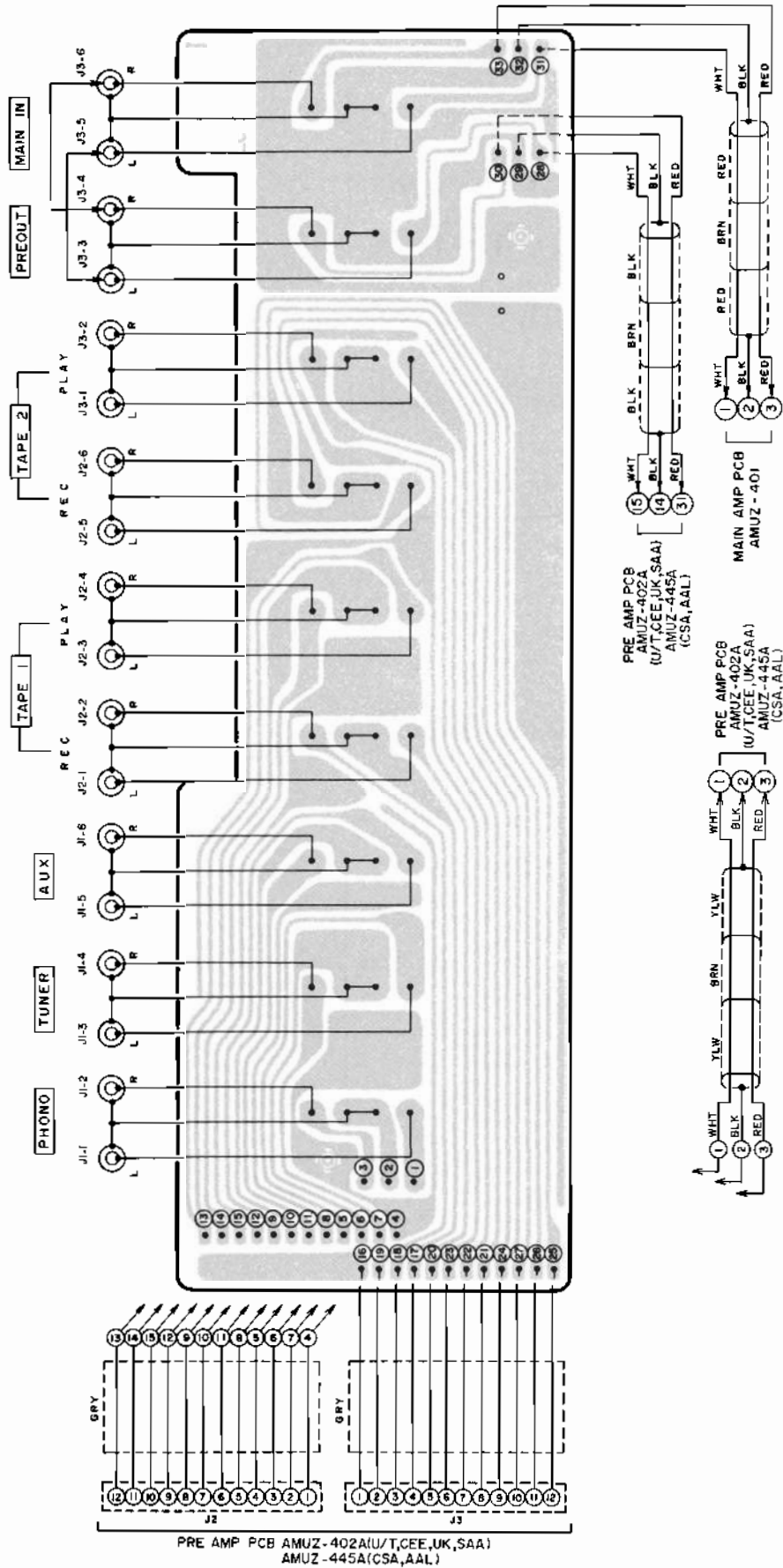

4) FUSE (U) P.C BOARD AMUZ-332 (U/T)

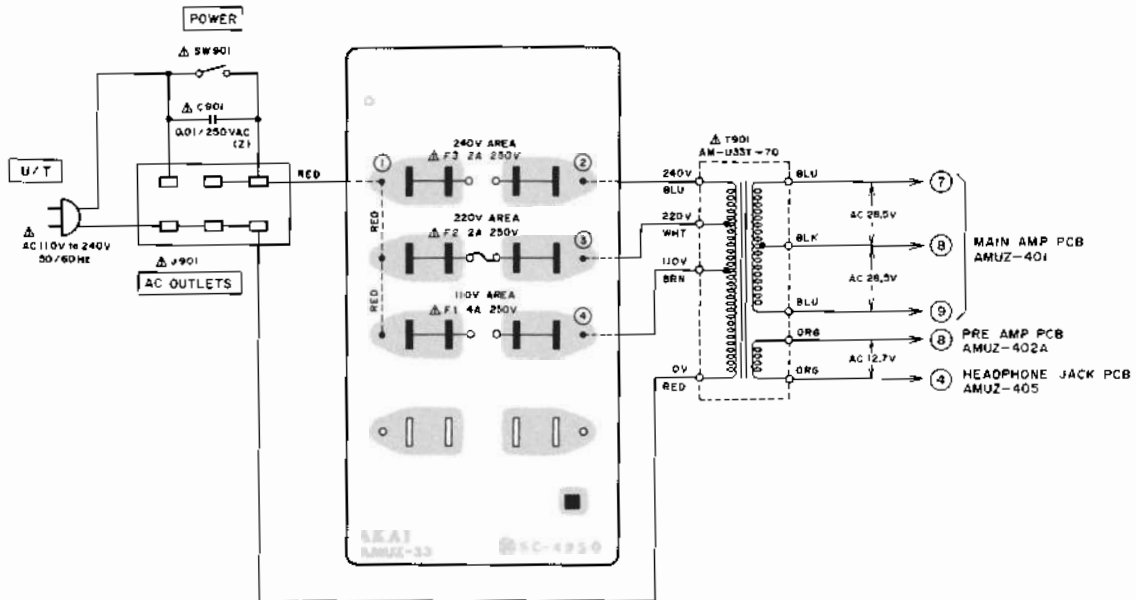

5) FUSE (C, A) P.C BOARD AMUZ-333 (CSA, AAL)

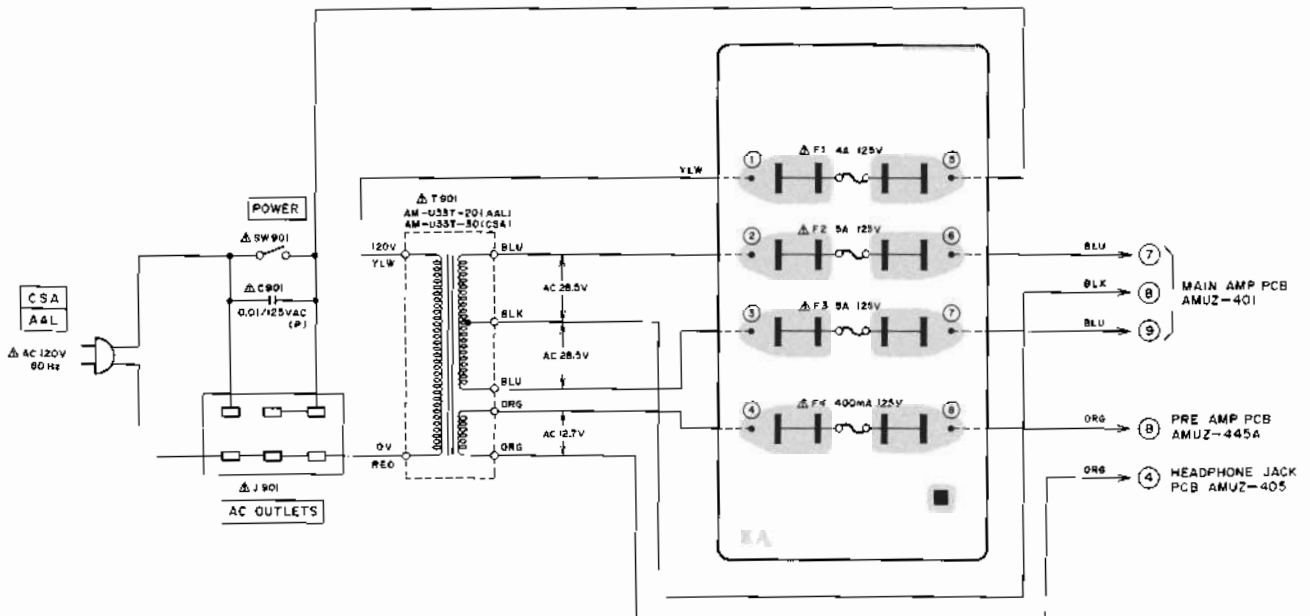

WARNING: Δ INDICATES SAFETY CRITICAL COMPONENTS. FOR CONTINUED SAFETY, REPLACE SAFETY CRITICAL COMPONENTS ONLY WITH MANUFACTURER'S RECOMMENDED PARTS.

AVERTISSEMENT: Δ IL INDIQUE LES COMPOSANTS CRITIQUES DE SÛRETÉ. POUR MAINTENIR LE DEGRÉ DE SÛRETÉ DE L'APPAREIL, NE REMPLACER LES COMPOSANTS DONT LE FONCTIONNEMENT EST CRITIQUE POUR LA SÛRETÉ QUE PAR DES PIÈCES RECOMMANDÉES PAR LE FABRICANT.

6) FUSE (E, B, S) P.C BOARD AMUZ-334 (CEE, UK, SAA)

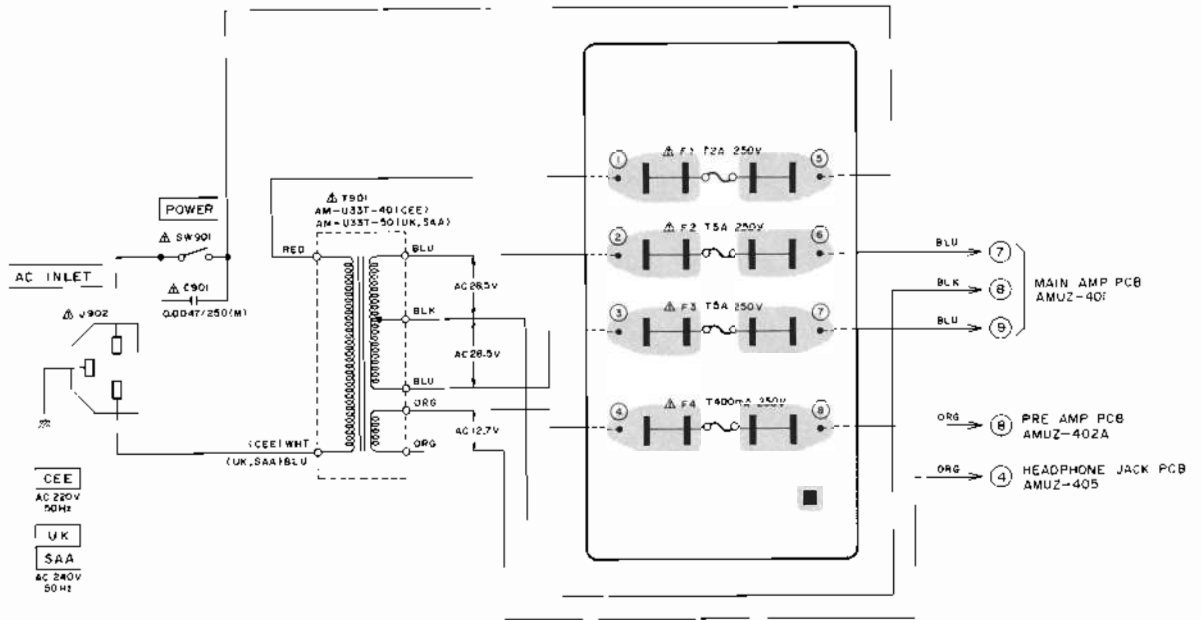

WARNING: Δ INDICATES SAFETY CRITICAL COMPONENTS. FOR CONTINUED SAFETY, REPLACE SAFETY CRITICAL COMPONENTS ONLY WITH MANUFACTURER'S RECOMMENDED PARTS.

AVERTISSEMENT: Δ IL INDIQUE LES COMPOSANTS CRITIQUES DE SÛRETÉ. POUR MAINTENIR LE DEGRÉ DE SÛRETÉ DE L'APPAREIL, NE REMPLACER LES COMPOSANTS DONT LE FONCTIONNEMENT EST CRITIQUE POUR LA SÛRETÉ QUE PAR DES PIÈCES RECOMMANDÉES PAR LE FABRICANT.

SECTION 3

STEREO INTEGRATED AMPLIFIER

MODEL **AM-U33J**

SERVICE MANUAL

TABLE OF CONTENTS

I.	SPECIFICATIONS	40
II.	DISMANTLING OF UNIT	41
III.	CONTROLS	42
IV.	PRINCIPAL PARTS LOCATION	43
V.	ADJUSTMENTS	44
VI.	CLASSIFICATION OF VARIOUS P.C BOARDS	44
	1. P.C BOARD TITLES AND IDENTIFICATION NUMBERS	44
	2. COMPOSITION OF VARIOUS P.C BOARDS	45

For basic adjustments, measuring methods, and operating principles, refer to GENERAL TECHNICAL MANUAL.

I. SPECIFICATIONS

RATED POWER OUTPUT		25 watts per channel, minimum RMS, at 8 ohms from 20 Hz to 20,000 Hz with no more than 0.05% total harmonic distortion.
POWER BANDWIDTH		10 Hz to 50 kHz/8 ohms (Total harmonic distortion: 0.1%)
SIGNAL TO NOISE RATIO (IHF-A)	PHONO AUX	82 dB 100 dB
CHANNEL SEPARATION (IHF)		Better than 55 dB at 1 kHz
DAMPING FACTOR		More than 50 (1 kHz, 8 ohms)
INPUT SENSITIVITY	PHONO AUX, TUNER TAPE	3 mV 150 mV 400 mV
OUTPUT LEVEL	TAPE REC	150 mV
FREQUENCY RESPONSE	PHONO (RIAA DEVIATION) TUNER, AUX, TAPE	±0.3 dB 6 Hz to 100 kHz +0 dB, -3 dB
TONE CONTROL	BASS TREBLE	±8 dB (100 Hz) ±8 dB (10 kHz)
POWER REQUIREMENT		AC 100V, 50/60 Hz
POWER CONSUMPTION		75W
DIMENSIONS		440(W) × 105(H) × 290(D) mm
WEIGHT		7.1 kg

* For improvement purposes, specifications and design are subject to change without notice.

II. DISMANTLING OF UNIT

AM-U33J

In case of trouble, etc. necessitating dismantling, please dismantle in the order shown in the photographs. Reassemble in reverse order.

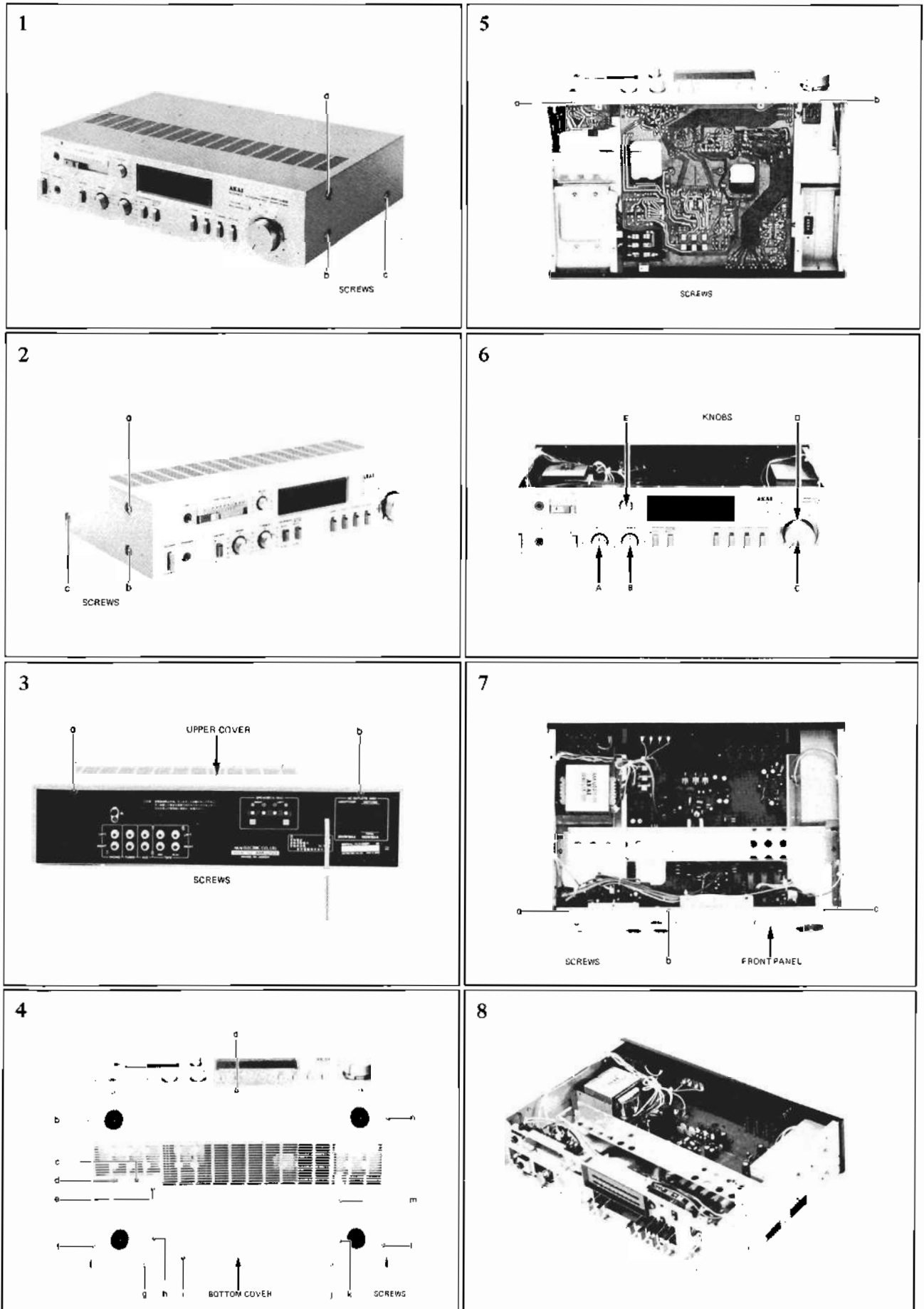

III. CONTROLS

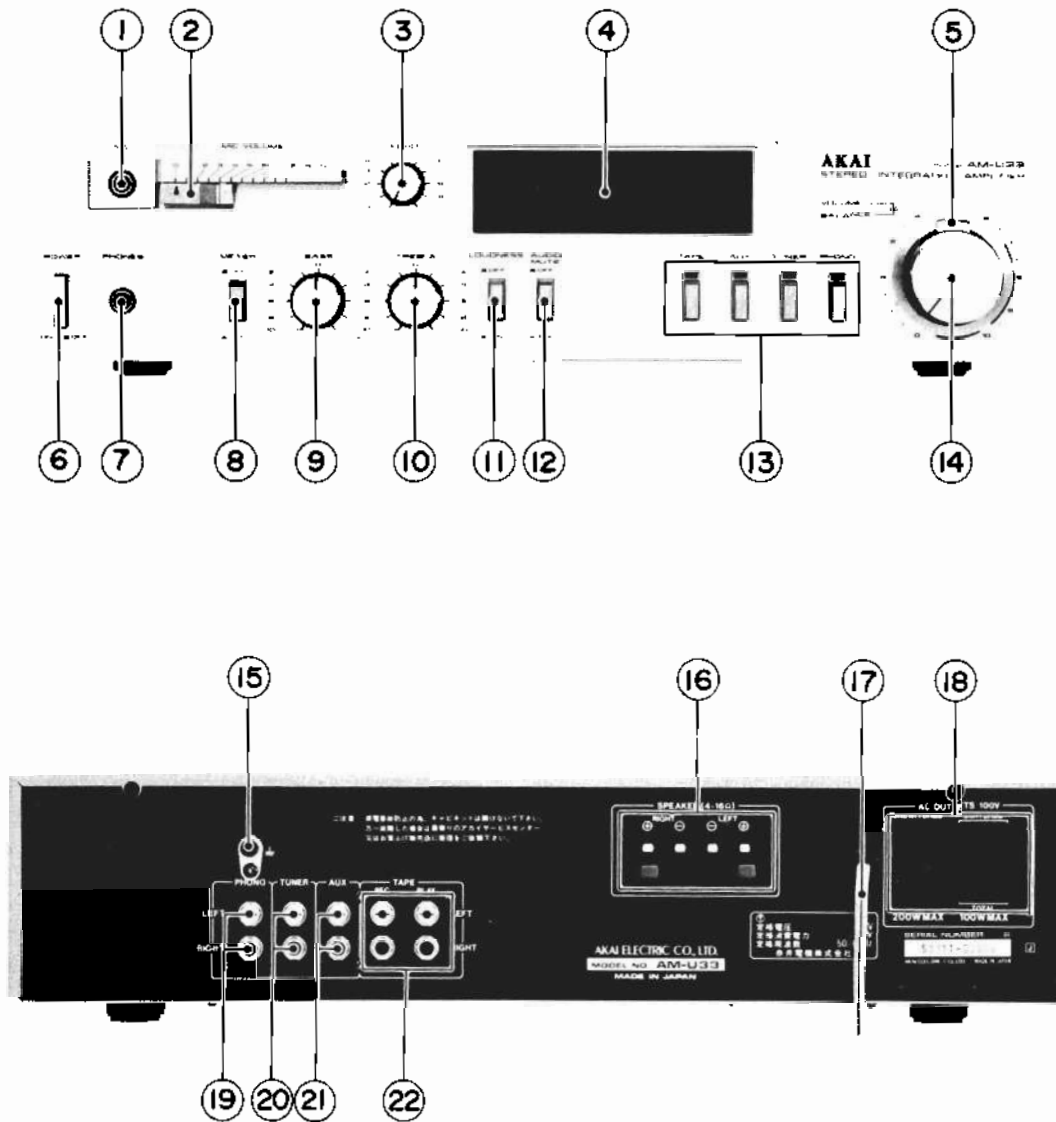

Fig. 1 Controls

- | | |
|----------------------------|---|
| 1. MIC JACK | 12. AUDIO MUTE SWITCH |
| 2. MIC VOLUME CONTROL | 13. INPUT SELECTOR SWITCHES and INDICATOR |
| 3. ECHO CONTROL | 14. VOLUME CONTROL |
| 4. LED BAR METER | 15. GROUND TERMINAL () |
| 5. STEREO BALANCE CONTROL | 16. SPEAKER TERMINALS |
| 6. POWER SWITCH | 17. AC CORD |
| 7. HEADPHONE JACK (PHONES) | 18. AC OUTLETS |
| 8. METER SELECTOR | 19. PHONO JACKS |
| 9. BASS CONTROL | 20. TUNER JACKS |
| 10. TREBLE CONTROL | 21. AUX JACKS |
| 11. LOUDNESS SWITCH | 22. TAPE REC/PLAY |

IV. PRINCIPAL PARTS LOCATION

AM-U33J

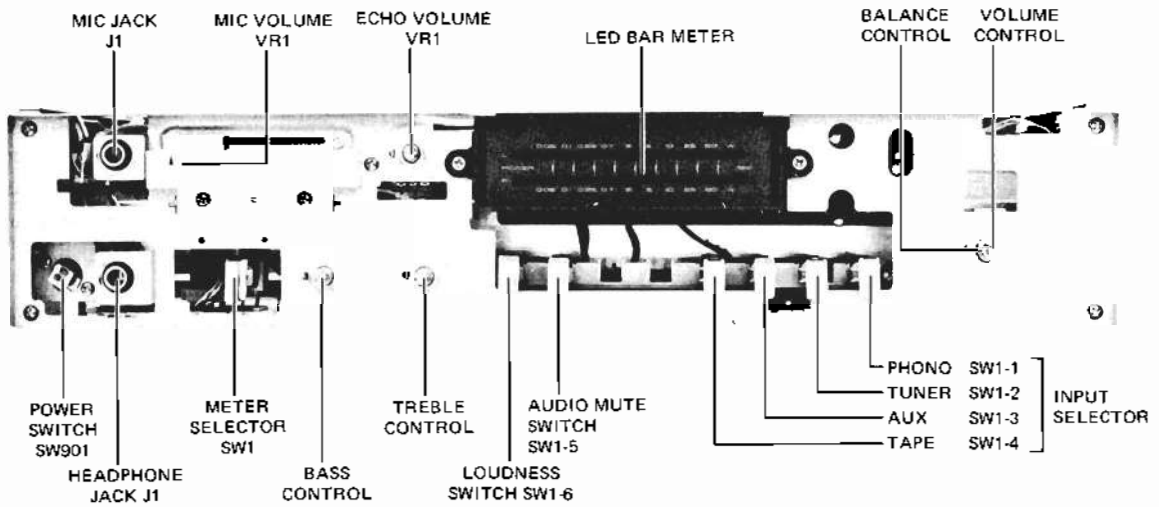

Fig. 2 Front View

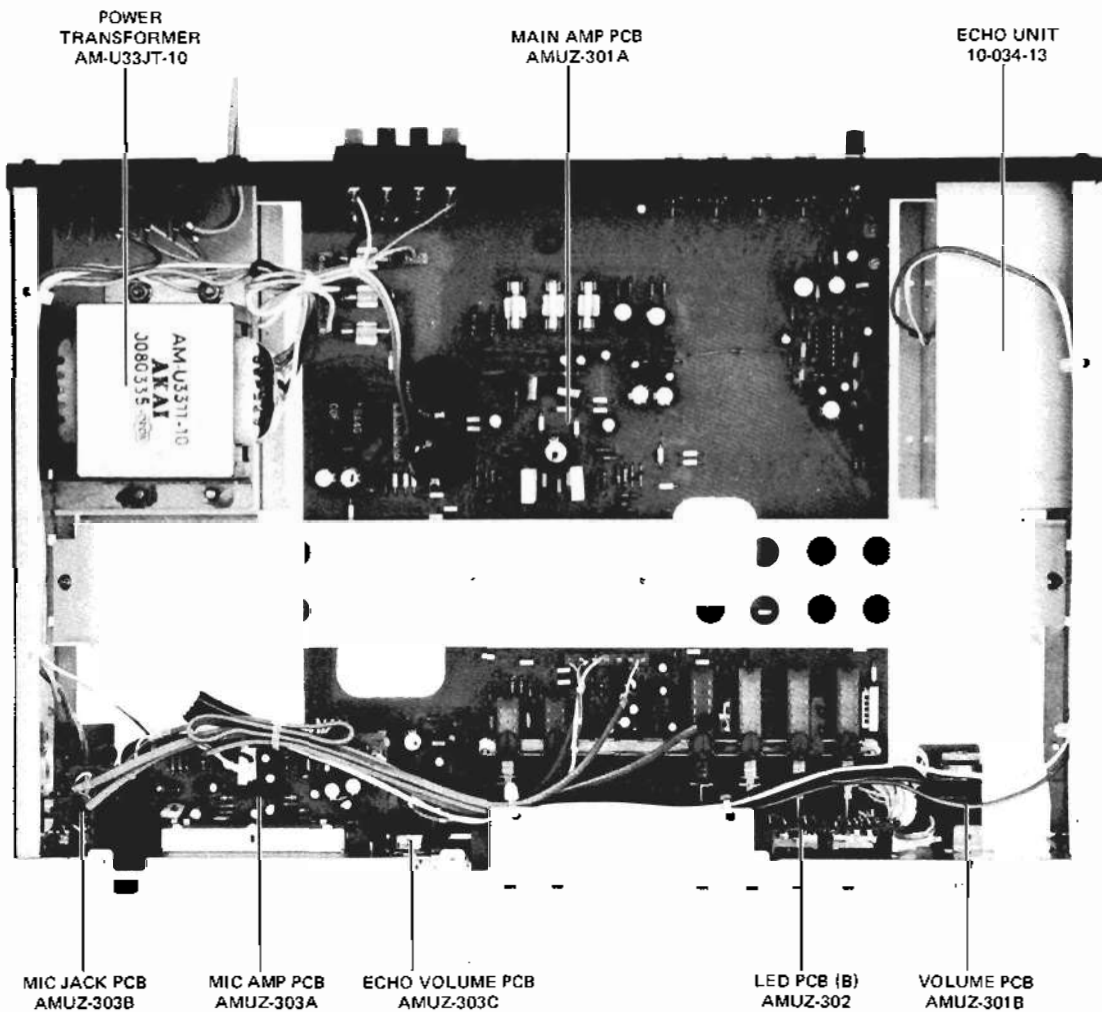

Fig. 3 Top View

V. ADJUSTMENTS

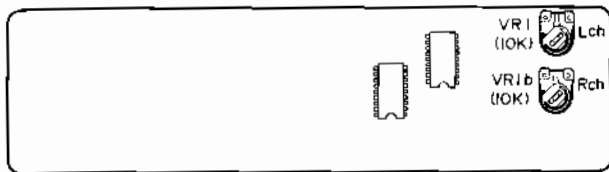

Fig. 4 LED P.C Board (B) AMUZ-302

POWER METER SENSITIVITY

ADJUSTMENT (Refer to Figs. 4, 5)

Set the Meter Range switch to "x1", and connect the load resistors ($R_L=8$ ohms) to Speaker terminals. Then apply a 1 kHz signal to the AUX input terminals, adjusting the input level so as to obtain the rated output voltage level (8.9V) at both ends of the load resistor.

Adjust VR1 (left channel) and VR1b (right channel) on the LED P.C Board (B) so that the 7th LED (10 watts) in the Power Meter lights up.

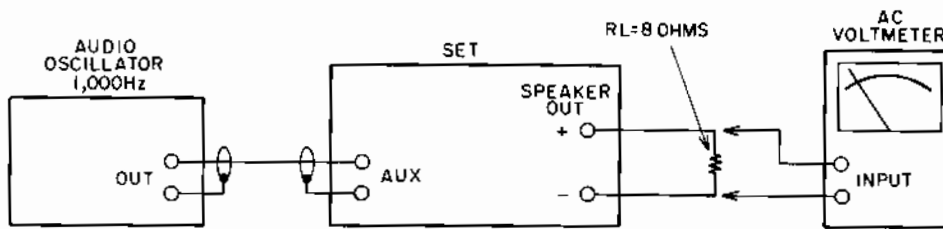

Fig. 5 Instrument Connections

VI. CLASSIFICATION OF VARIOUS P.C BOARDS

1. P.C BOARD TITLES AND IDENTIFICATION NUMBERS

P.C Board Title	P.C Board Number
Main Amp P.C Board	AMUZ-301A
Volume P.C Board	AMUZ-301B
LED P.C Board (A)	AMUZ-301C
Headphone P.C Board	AMUZ-301D
Interconnect P.C Board	AMUZ-301E
LED P.C Board (B)	AMUZ-302
Mic Amp P.C Board	AMUZ-303A
Mic Jack P.C Board	AMUZ-303B
Echo Volume P.C Board	AMUZ-303C

2. COMPOSITION OF VARIOUS P.C BOARD

1) MAIN AMP P.C BOARD AMUZ-301A and HEADPHONE P.C BOARD AMUZ-301D

WARNING: Δ INDICATES SAFETY CRITICAL COMPONENTS. FOR CONTINUED SAFETY, REPLACE SAFETY CRITICAL COMPONENTS ONLY WITH MANUFACTURER'S RECOMMENDED PARTS.

AVERTISSEMENT: Δ IL INDIQUÉ LES COMPOSANTS CRITIQUES DE SÛRETÉ. POUR MAINTENIR LE DEGRÉ DE SÛRETÉ DE L'APPAREIL, NE REMPLACER LES COMPOSANTS DONT LE FONCTIONNEMENT EST CRITIQUE POUR LA SÛRETÉ QUE PAR DES PIÈCES RECOMMANDÉES PAR LE FABRICANT.

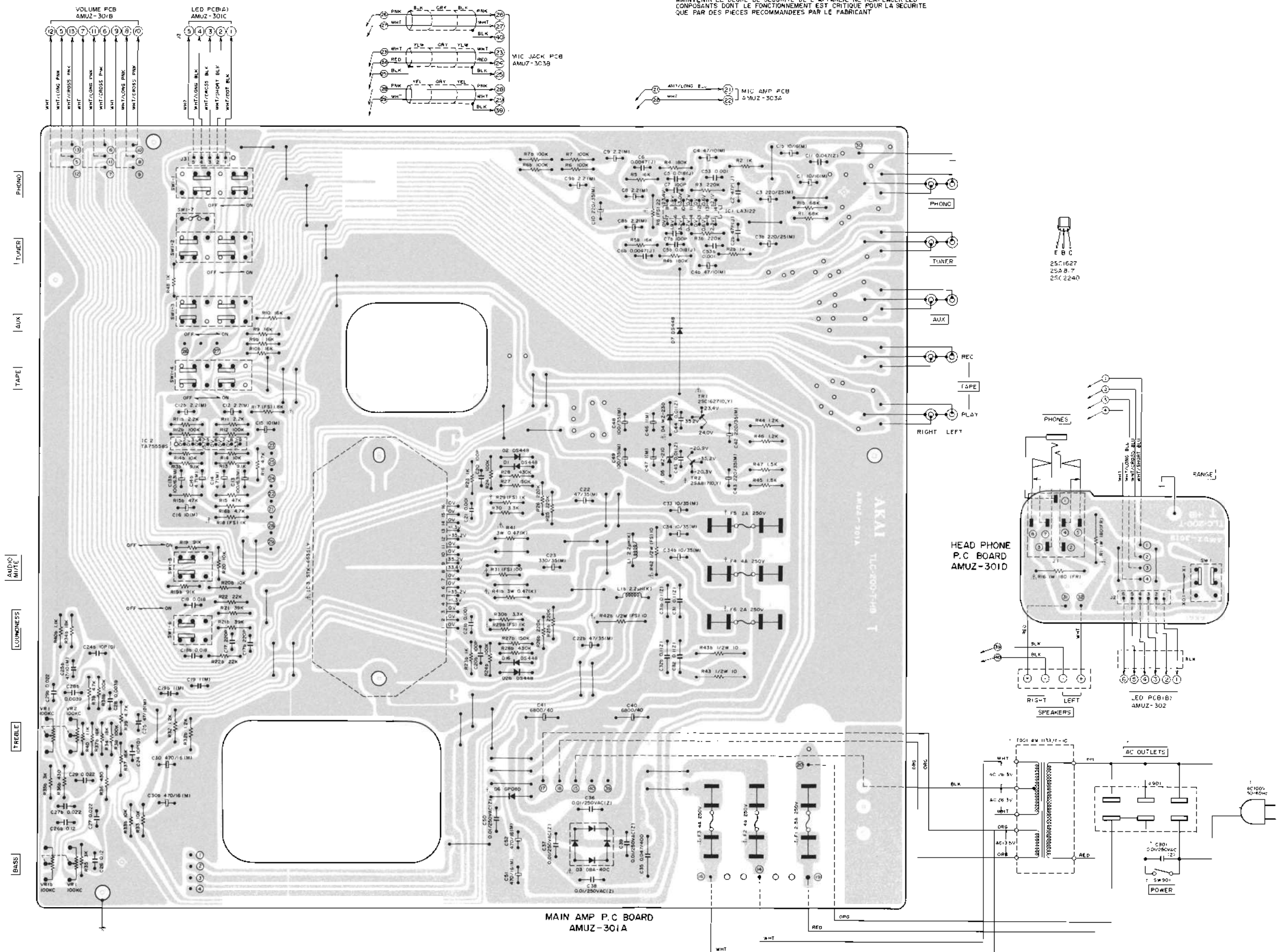

2) VOLUME P.C BOARD AMUZ-301B, LED P.C BOARD (A) AMUZ-301C and LED P.C BOARD (B) AMUZ-302

WARNING: INDICATES SAFETY CRITICAL COMPONENTS. FOR CONTINUED SAFETY, CRITICAL COMPONENTS ONLY WITH MANUFACTURER'S RECOMMENDED PARTS.
 AVERTISSEMENT: IL INDIQUE LES COMPOSANTS CRITIQUES DE SÛRETÉ. POUR MAINTENIR LE DEGRÉ DE SÛRETÉ DE L'APPAREIL, NE REMPLACER LES COMPOSANTS DONT LE FONCTIONNEMENT EST CRITIQUE POUR LA SÛRETÉ QUE PAR DES PIÈCES RECOMMANDÉES PAR LE FABRICANT.

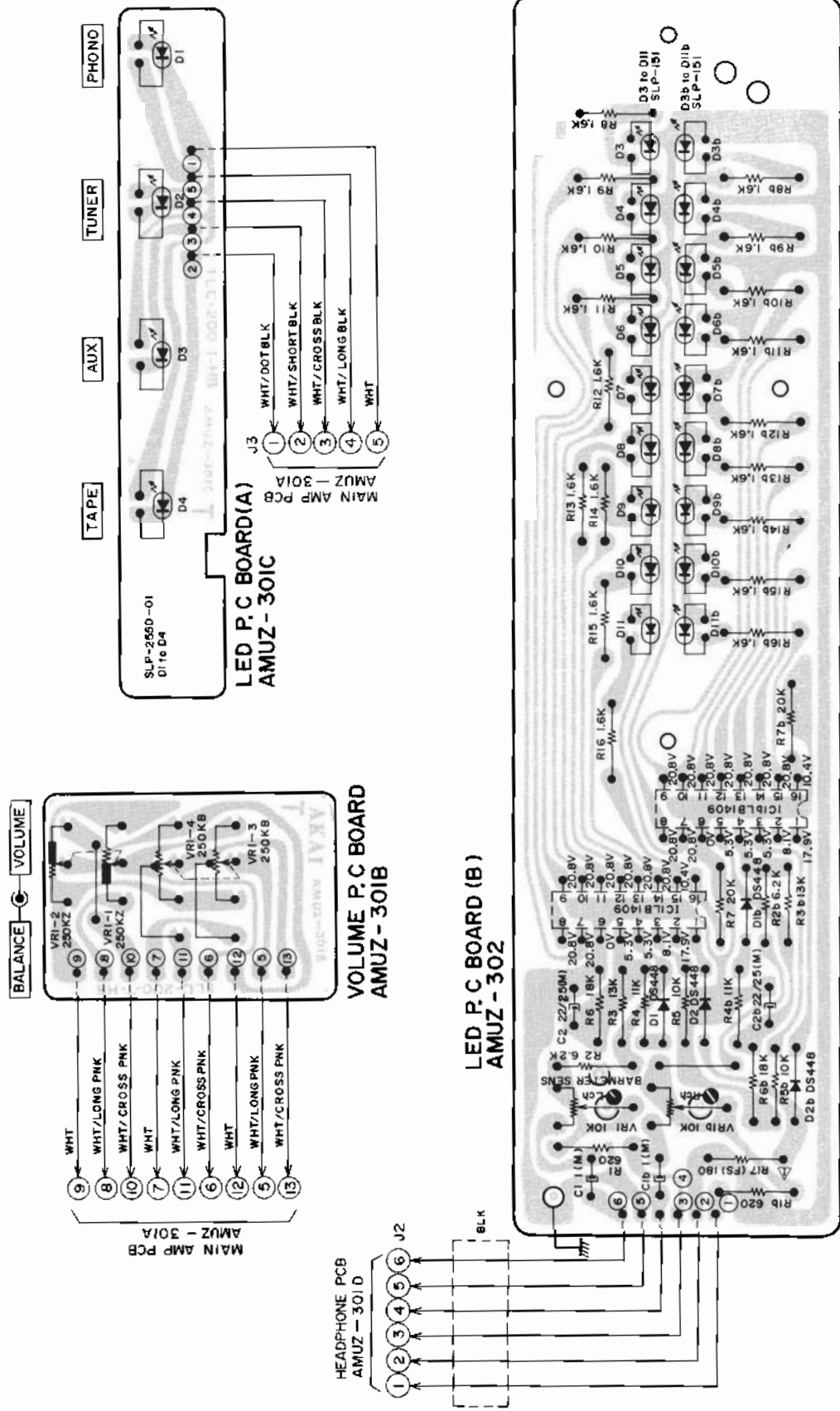

3) MIC AMP P.C BOARD AMUZ-303A, MIC JACK P.C BOARD AMUZ-303B, ECHO VOLUME P.C BOARD AMUZ-303C and INTERCONNECT P.C BOARD AMUZ-301E

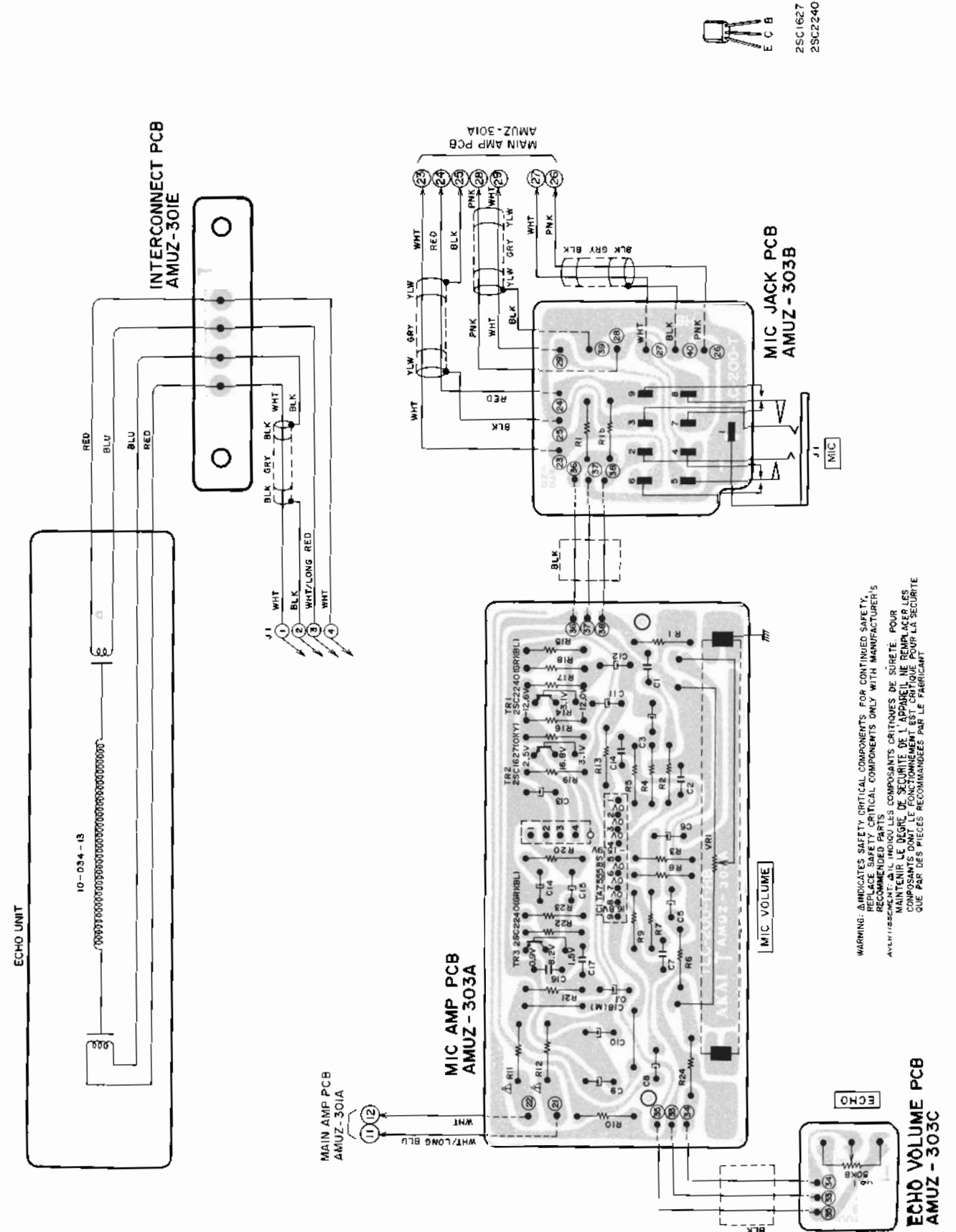

E C B
 25C1627
 25C2240

WARNING: INDICATES SAFETY CRITICAL COMPONENTS. FOR CONTINUED SAFETY, CRITICAL COMPONENTS ONLY WITH MANUFACTURER'S RECOMMENDED PARTS.
 AVERTISSEMENT: IL INDIQUE LES COMPOSANTS CRITIQUES DE SÛRETÉ. POUR MAINTENIR LE DEGRÉ DE SÛRETÉ DE L'APPAREIL, NE REMPLACER LES COMPOSANTS DONT LE FONCTIONNEMENT EST CRITIQUE POUR LA SÛRETÉ QUE PAR DES PIÈCES RECOMMANDÉES PAR LE FABRICANT.

ECHO
 MIC VOLUME PCB
 AMUZ - 303C

SECTION 4

PARTS LIST

TABLE OF CONTENTS

I. MODEL AT-K33/L/J	
1. RECOMMENDED SPARE PARTS	53
2. TUNER P.C BOARD BLOCK	53
3. COUNTER P.C BOARD BLOCK	54
4. LED P.C BOARD BLOCK	54
5. CAL TONE P.C BOARD BLOCK (AT-K33J ONLY)	55
6. ANT SW P.C BOARD BLOCK (AT-K33L ONLY)	55
7. ASSEMBLY BLOCK	56
8. FINAL ASSEMBLY BLOCK	58
II. MODEL AM-U33	
1. RECOMMENDED SPARE PARTS	59
2. MAIN AMP P.C BOARD BLOCK	59
3. PRE AMP (A) P.C BOARD BLOCK	60
4. LED (A) P.C BOARD BLOCK	60
5. LED (B) P.C BOARD BLOCK	60
6. HEADPHONE P.C BOARD BLOCK	61
7. RANGE SELECT P.C BOARD BLOCK	61
8. PIN JACK P.C BOARD BLOCK	61
9. ASSEMBLY BLOCK	62
10. FINAL ASSEMBLY BLOCK	64
III. MODEL AM-U33J	
1. RECOMMENDED SPARE PARTS	65
2. MAIN AMP P.C BOARD BLOCK	65
3. MIC AMP P.C BOARD BLOCK	66
4. LED (B) P.C BOARD BLOCK	66
5. ASSEMBLY BLOCK	67
6. FINAL ASSEMBLY BLOCK	68
INDEX	
1. MODEL AT-K33/L/J	69
2. MODEL AM-U33	69
3. MODEL AM-U33J	70

Resistor and Capacitor which is not listed in this parts list, please refer to COMMON LIST FOR SERVICE PARTS.

HOW TO USE THIS PARTS LIST

1. This parts list is compiled by various individual blocks based on assembly process.
2. When ordering parts, please describe parts number, serial number, and model number in detail.
3. How to read List

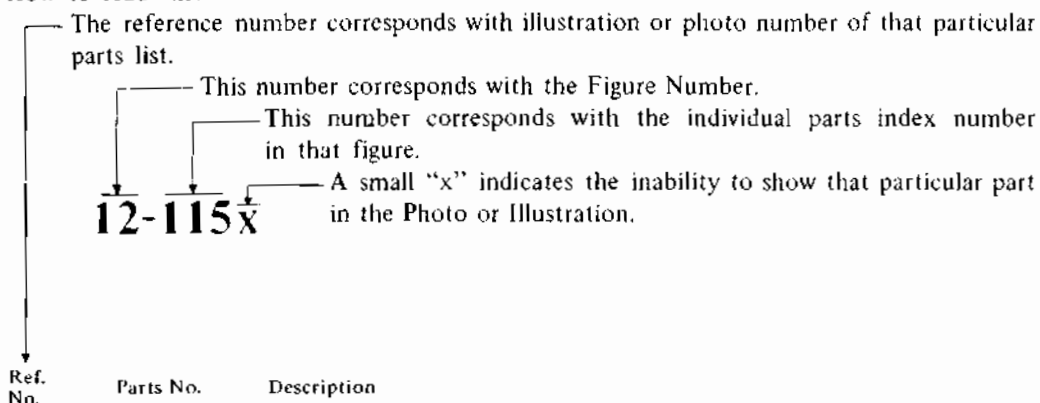

4. The symbol numbers shown on the P.C. Board list can be matched with the Composite Views of Components of the Schematic Diagram or Service Manual.
5. Please utilize separate "Common List for Service Parts" for Resistor Parts orders.
6. The shape of the parts and parts name, etc. can be confirmed by comparing them with the parts shown on the Electrical Parts Table of P.C. Board.
7. Both the kind of part and installation position can be determined by the Parts Number. To determine where a parts number is listed, utilize Parts Index at end of Parts List.
It is necessary first of all to find the Parts Number. This can be accomplished by using the Reference Number listed at right of parts number in the Parts Index. (meaning of ref. no. outlined in Item 3 above).
8. Utilize separate "Price List for Parts" to determine unit price. The most simple method of finding parts Price is to utilize the reference number.

- CAUTION:**
1. When placing an order for parts, be sure to list the parts no. model no., and description. There are instances in which if any of this information is omitted, parts cannot be shipped or the wrong parts will be delivered.
 2. Please be careful not to make a mistake in the parts no. If the parts no. is in error, a part different from the one ordered may be delivered.
 3. Because parts number and parts unit supply in the Preliminary Service Manual (Basic Parts List) may be partially changed, please use this parts list for all future reference.

WARNING:  INDICATES SAFETY CRITICAL COMPONENTS. FOR CONTINUED SAFETY, REPLACE SAFETY CRITICAL COMPONENTS ONLY WITH MANUFACTURER'S RECOMMENDED PARTS.

AVERTISSEMENT:  IL INDIQU LES COMPOSANTS CRITIQUES DE SURETE. POUR MAINTENIR LE DEGRE DE SECURITE DE L'APPAREIL NE REMPLACER LES COMPOSANTS DONT LE FONCTIONNEMENT EST CRITIQUE POUR LA SECURITE QUE PAR DES PIECES RECOMMANDEES PAR LE FABRICANT.

I. MODEL AT-K33/L/J

1. RECOMMENDED SPARE PARTS

Because, if the parts listed below are on hand, almost any repair can be accomplished, we suggest that you stock these Recommended Spare Parts Items.

REF. NO.	PARTS NO.	DESCRIPTION
1-1	BT328843	△ TRANS POWER AT-K200T-30 (C,A)
1-2	BT328844	△ TRANS POWER AT-K200T-40(E)
1-3	BT328845	△ TRANS POWER AT-K200T-50 (B,S)
1-4	BT328842	△ TRANS POWER AT-K200T-70(U)
1-5	BT200953	△ TRANS POWER AT-K33T-10 (J)
1-6	EC616342	C S-FIX H CTY122D33 1.5-16
1-7	ED322247	D LED SLP-151D RED
1-8	ED322184	D LED SLP-152D RED
1-9	ED322215	D LED SLP-251D GRN
1-10	ED200469	D SILICON H DS448 FA1 F10
1-11	ED322238	D SILICON 1B4B41 100/1.0A
1-12	ED224526	D SILICON 10D1 100/1.0A
1-13	ED309959	D ZENER H HZ5 C3
1-14	ED323216	D ZENER H 05Z15 U
1-15	ED325080	D ZENER H 05Z9.1 L
1-16	EE200184	ANT BAR AT-K200 MW
1-17	EE200810	ANT BAR AT-K22L LW/MW
1-18	EE200954	FRONT END FF1341J13 76-90MHZ (J)
1-19	EE325737	FRONT END FF136U12 87-108MHZ (EXCEPT J)
1-20	EF300590	△ FUSE EAWK T 250V 0.40A (E,B,S)
1-21	EF308933	△ FUSE TSC A 250V 0.20A (U)
1-22	EF309389	△ FUSE TSC A 250V 0.40A (U)
1-23	EF308848	△ FUSE TSC 125V 0.40A (C,A)
1-24	EI322248	IC LA1231N
1-25	EI293185	IC LA1240
1-26	EI650597	IC LA3350S
1-27	EI315491	IC LB1405S
1-28	EI328850	IC LC7259
1-29	EI328849	IC M54459L
1-30	EI323247	IC TA7324P
1-31	EI323231	OSC X'TAL 4MHZ
1-32	EJ301513	△ SOCKET INLET S-16453 E 2P (E,B,S)
1-33	EM328848	IND LE SL-1713W CHARACTER
1-34	ER307204	FILTER CE CFMA-008 0.468MHZ
1-35	ER307201	FILTER CE SFE10.7MM-Z 10.7MHZ
1-36	ER328855	FILTER LC LP 12A1251 AKAI
1-37	ES315159	△ SW PUSH SDG1P 01-1 J (J)
1-38	ES310839	△ SW PUSH SDG1P-E 01-1 E (U,E,B,S)
1-39	ES665875	△ SW PUSH SDG1P-J 01-1 UC (C,A)
1-40	ES201979	SW PUSH SUF12 2-02-02N (EXCEPT L)
1-41	ES319168	SW PUSH SUF12 2-04-02N
1-42	ES200829	SW PUSH SUF22 2 THROW (L)
1-43	ES201948	SW PUSH SUF22 2 THROW (EXCEPT L)
1-44	ES200955	SW PUSH 12T-QIS003 2-04-02N
1-45	ES328851	SW PUSH 12T-9S420 2-02-02N (L)
1-46	ET323232	TR FET 2SK19 Y
1-47	ET200506	TR 2SC2603 F
1-48	ET316171	TR 2SC536K-NP E,F
1-49	ET316643	TR 2SC536K-NP F,G
1-50	ET618873	TR 2SC930 E,F
1-51	EV427858	R S-FIX H SR19R 3P 0.15W 472
1-52	EV604438	R S-FIX H V10K8-4-2 3P 103
1-53	EV323213	R S-FIX H V10K8-4-2 3P 302
1-54	EV593368	R S-FIX H V10K8-4-2 3P 303
1-55	EV499375	R S-FIX H V10K8-4-2 3P 501

2. TUNER P.C BOARD BLOCK

REF. NO.	PARTS NO.	DESCRIPTION
2-1	BAA3010C020A	TUNER PC BLK AT-K33(U)
2-2	BAA3010A050A	TUNER PC BLK AT-K33J (J)
2-3	BAA3010C020B	TUNER PC BLK AT-K33(C) (C,A)
2-4	BAA3010C020C	TUNER PC BLK AT-K33(E) (E,S)
2-5	BAA3010E030A	TUNER PC BLK AT-K33L
2-6	EE325737	FRONT END FF136U12 87-108MHZ (EXCEPT J)
2-7	EE200954	FRONT END FF1341J13 76-90MHZ (J)
2-IC1	EI322248	IC LA1231N
2-IC2	EI650597	IC LA3350S
2-IC3	EI293185	IC LA1240
2-IC4	EI315491	IC LB1405S
2-TR1	ET618873	TR 2SC930 E,F
2-TR2to4	ET316643	TR 2SC536K-NP F,G
2-TR5,6	ET200506	TR 2SC2603 F
2-TR7to9	ET316643	TR 2SC536K-NP F,G
2-TR10	ET323232	TR FET 2SK19 Y
2-TR11	ET316643	TR 2SC536K-NP F,G
2-D1to8	ED200469	D SILICON H DS448 FA1 F10
2-D9	ED323216	D ZENER H 05Z15 U
2-D10	ED322238	D SILICON 1B4B41 100/1.0A
2-D11	ED224526	D SILICON 10D1 100/1.0A
2-J1	EJ323227	PIN J T5727-A P 2P
2-SW1	ES201979	SW PUSH SUF12 2-02-02N (EXCEPT L)
2-SW1	ES328851	SW PUSH 12T-9S420 2-02-02N (L)
2-SW2	ES201948	SW PUSH SUF22 2 THROW (EXCEPT L)
2-SW3	ES200829	SW PUSH SUF22 2 THROW (L)
2-VR1,2	EV593368	R S-FIX H V10K8-4-2 3P 303
2-VR3	EV427858	R S-FIX H SR19R 3P 0.15W 472
2-VR4	EV499375	R S-FIX H V10K8-4-2 3P 501
2-L1,2	EO328137	COIL FIX 2 NI-0036 2.2μH
2-T1	EO328854	COIL DET2 Q228CEL-1098R
2-T2	ER293398	COIL IFT RMC-42246BCH 468KHZ
2-T3	ER307204	FILTER CE CFMA-008 0.468MHZ
2-T4	EO307186	COIL OSC 2 RWR-43208N 160μH
2-T5	EO201252	COIL OSC2 RNR-44498N 600μH (L)
2-FL1,2	ER307201	FILTER CE SFE10.7MM-Z 10.7MHZ
2-FL3,4	ER328855	FILTER LC LP 12A1251 AKAI
2-VC1,2	EC616342	C S-FIX H CTY122D33 1.5-16
2-VC3	EC616342	C S-FIX H CTY122D33 1.5-16 (L)
2-TM1	EJ309941	TERMINAL W/SCREW UB-1059 P 4P
2-R7,8	ER324337	R CB H SNP FS RDS 1/4W 560J
2-R13,14	ER324337	R CB H SNP FS RDS 1/4W 560J
2-R31,32	ER324337	R CB H SNP FS RDS 1/4W 560J
2-R56,57	ER324337	R CB H SNP FS RDS 1/4W 560J
2-R65,66	ER324337	R CB H SNP FS RDS 1/4W 560J
2-R73to75	ER324337	R CB H SNP FS RDS 1/4W 560J
2-R85	ER324185	R CB H SNP FS RDS 1/4W 221J
2-R97,98	ER324480	R CB H SNP FS RDS 1/4W 470J
2-C33	EC328862	C STY V F05 CQF09 152J 50DC
2-C59	EC314996	C STY V SNP CQFS391J 50DC
2-C68	EC201253	C STY V F05 CQF09 161J 50DC (L)
2-C76,77	EC328856	C STY V F05 CQF09 331K 50DC
2-C84,85	EC320548	C CE V F 103Z 250AC
2-C87	EC320548	C CE V F 103Z 250AC

REF. NO.	PARTS NO.	DESCRIPTION
	MUTE PC BLK	
2-IC1	EI323247	IC TA7324P
2-D1	ED200469	D SILICON H DS448 FA1 F10

4. LED P.C BOARD BLOCK

REF. NO.	PARTS NO.	DESCRIPTION
4-D1	ED322247	D LED SLP-151D RED
4-D2	ED322215	D LED SLP-251D GRN
4-D3	ED322184	D LED SLP-152D RED

3. COUNTER P.C BOARD BLOCK

REF. NO.	PARTS NO.	DESCRIPTION
3-1	BAA3010C050A	COUNTER PC BLK AT-K33
3-2	BAA3010A070A	COUNTER PC BLK AT-K33J
3-IC1	EI328849	IC M54459L
3-IC2	EI328850	IC LC7259
3-TR1	ET618873	TR 2SC930 E,F
3-TR2	ET316171	TR 2SC536K-NP E,F
3-D1,2	ED200469	D SILICON H DS448 FA1 F10
3-D3	ED325080	D ZENER H 05Z9.1 L
3-D4	ED309959	D ZENER H HZ5 C3
3-VR1,2	EV604438	R S-FIX H V10K8-4-2 3P 103
3-L1to3	EO328137	COIL FIX 2 NI-0036 2.2μH
3-IN1	EM328848	IND LE SL-1713W
		CHARACTER
3-X1	EI323231	OSC X'TAL 4MHz
3-R35	ER324185	R CB H SNP FS RDS 1/4W 221J
3-R38	ER324186	R CB H SNP FS RDS 1/4W 681J

**5. CAL TONE P.C BOARD BLOCK
(AT-K33J ONLY)**

REF. NO.	PARTS NO.	DESCRIPTION
5-IC1	EI323247	IC TA7324P
5-TR1	ET316643	TR 2SC536K-NP F,G
5-D1	ED200469	D SILICON H DS448 FA1 F10
5-SW1	ES200955	SW PUSH 12T-QIS003 2-04-02N
5-VR1	EV323213	R S-FIX H V10K8-4-2 3P 302

**6. ANT SW P.C BOARD BLOCK
(AT-K33L ONLY)**

REF. NO.	PARTS NO.	DESCRIPTION
6-SW1	ES319168	SW PUSH SUF12 2-04-02N
6-L1	EO485278	COIL FIX1 FLOSH 220 μ H K
6-T1	EO324453	COIL VARI2 RUR-44313N
6-VC1,2	EC616342	C S-FIX H CTY122D33 1.5 μ F

7. ASSEMBLY BLOCK

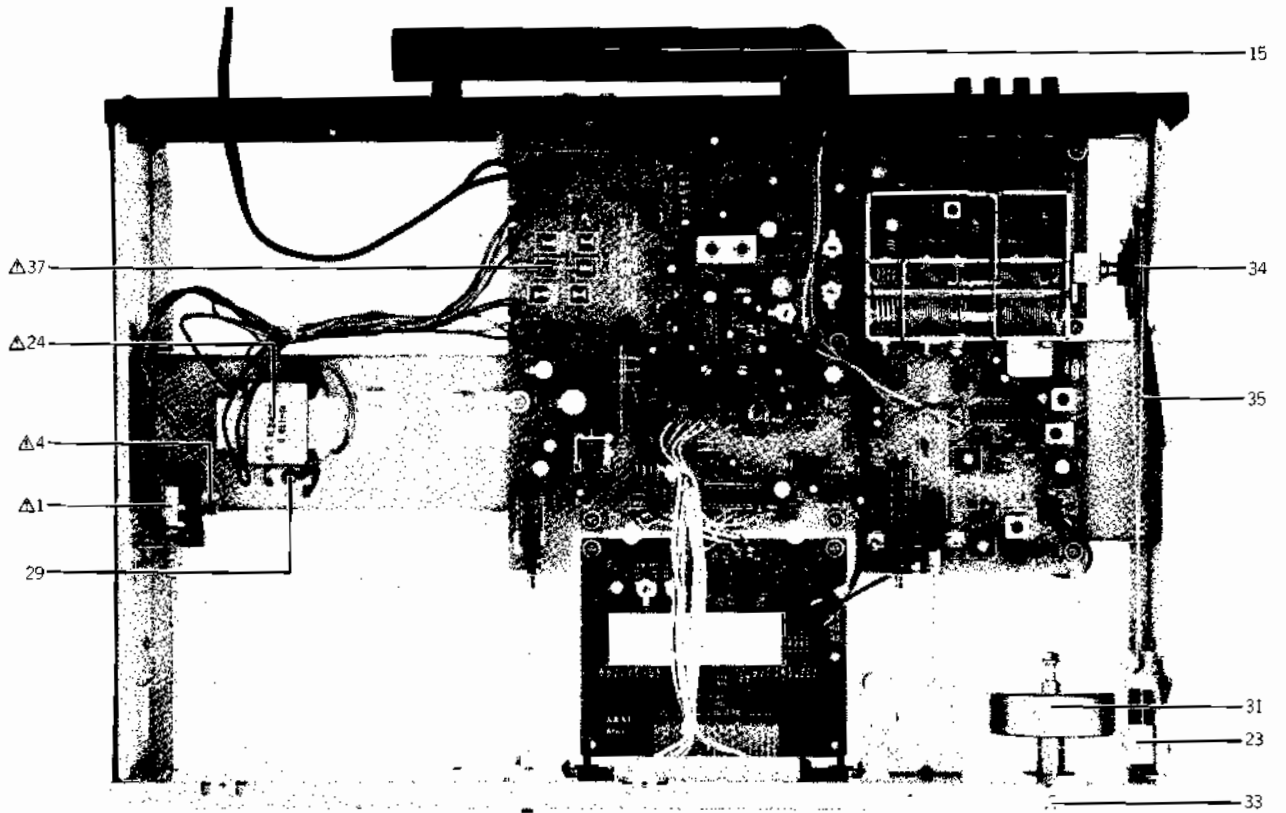

ASSEMBLY BLOCK

REF. NO.	PARTS NO.	DESCRIPTION
POWER SW BLK		
7-1	ES310839	△ SW PUSH SDG1P-E 01-1 E (U,E,B,S)
7-2x	ES315159	△ SW PUSH SDG1P 01-1 J (J)
7-3x	ES665875	△ SW PUSH SDG1P-J 01-1 UC (C,A)
7-4	EC320548	△ C CE V F 103Z 250AC (U,J)
7-5x	EC314688	△ C CE V FZ 103P 125AC (C,A)
7-6x	EC330307	△ C MMY V ECQUF 472M 250AC (E,B,S)
ASSEMBLY BLK		
7-7	SP200689B	REAR PANEL AT-K33(U)
7-8x	SP200689A	REAR PANEL AT-K33J
7-9x	SP200689C	REAR PANEL AT-K33(C)
7-10x	SP200689D	REAR PANEL AT-K33(A)
7-11x	SP200689E	REAR PANEL AT-K33(E)
7-12x	SP200689F	REAR PANEL AT-K33(S)
7-13x	SP200689G	REAR PANEL AT-K33L(E)
7-14x	SP200689H	REAR PANEL AT-K33L (B,S)
7-15	EE200184	ANT BAR AT-K200 MW
7-16x	EE200810	ANT BAR AT-K22L LW/MW
7-17	EW306428	△ AC CORD 2 CORES KP-205A, VFF UCJ (U)
7-18x	EW306427	△ AC CORD 2 CORES KP-211, VFF J (J)
7-19x	EW305691	△ AC CORD 2 CORES KP-8, SPT-1 UC (C,A)
7-20	SZ631945	STRAIN RELIEF SR-4N-4
7-21x	EJ301513	△ SOCKET INLET S-16453 E 2P (E,B,S)
7-22	ZS319460	T2BR30x06STL BZN PROJECTION
7-23	MR308836	PULLEY
7-24	BT328842	△ TRANS POWER AT-K200T-70(U)
7-25x	BT200953	△ TRANS POWER AT-K33T-10 (J)
7-26x	BT328843	△ TRANS POWER AT-K200T-30 (C,A)
7-27x	BT238844	△ TRANS POWER AT-K200T-40(E)
7-28x	BT328845	△ TRANS POWER AT-K200T-50 (B,S)
7-29	ZS315511	ST PAN30x06STL CMT CUP
7-30x	ZW698308	RV NYL30x055 BL
7-31	TA328846	TUNING WHEEL
7-32x	ZW436026	PW92x150x050STL CMT
7-33	ZW554624	E JACK NUT SPCC N13
7-34	TA322250	DIAL WHEEL ASSY
7-35	TA307160	DIAL STRING TK-1064 D0.5
7-36x	EF309389	△ FUSE TSC A 250V 0.40A(U)(F1)
7-37	EF308933	△ FUSE TSC A 250V 0.20A (U)(F2,3)
7-38x	EF308848	△ FUSE TSC 125V 0.40A (C,A)(F1)
7-39x	EF300590	△ FUSE EAWK T 250V 0.40A (E,B,S)(F1)
7-40x	SP200694	BOTTOM PLATE
7-41x	SA311742	ROUND FOOT
7-42x	ZS463094	T2BID40x08STL CMT
7-43x	ZS447840	T2BR30x08STL CMT
7-44x	ZW305013	RV POP32 (A)
7-45x	EW315767	△ AC CORD 2 CORES KP-419C/KS-15 E (E)
7-46x	EW302995	△ AC CORD 2 CORES VM-0112 B (B)
7-47x	EW322401	△ AC CORD 2 CORES KP-560/S-15 S (S)

8. FINAL ASSEMBLY BLOCK

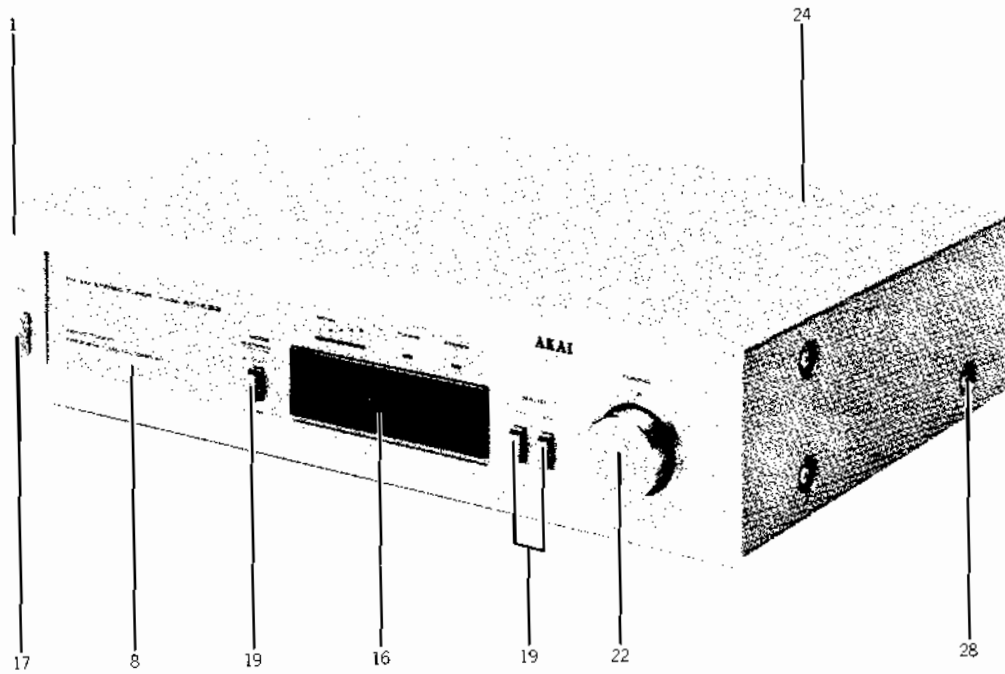

FINAL ASSEMBLY BLOCK

REF. NO.	PARTS NO.	DESCRIPTION
FRONT PANEL BLK		
8-1	BDA3010A020C	FRONT PANEL BLK AT-K33
8-2x	BDA3010A020D	FRONT PANEL BLK AT-K33-BL
8-3x	BDA3010A100A	FRONT PANEL BLK AT-K33J
8-4x	BDA3010A100B	FRONT PANEL BLK AT-K33J-BL
8-5x	BDA3010E020A	FRONT PANEL BLK AT-K33L
8-6x	BDA3010E020B	FRONT PANEL BLK AT-K33L-BL
FINAL ASSEMBLY BLK		
8-7x	TA200910	FILTER
8-8	SP201792A	SUB PANEL (A)
8-9x	SP201792C	SUB PANEL (B) (L)
8-10x	SE201787A	ESCUTCHEON (C)
8-11x	SP201792B	SUB PANEL (A-BL)
8-12x	SP201792D	SUB PANEL (B-BL) (L)
8-13x	SE201787B	ESCUTCHEON (C-BL)
8-14x	TA200911A	INDICATOR (J)
8-15x	TA200911B	INDICATOR (BL) (J)
8-16	SZ321494	METER WINDOW
8-17	SB316498	BUTTON (B)
8-18x	SB316499	BUTTON (B-BL)
8-19	SB200915A	BUTTON
8-20x	SB200915B	BUTTON (BL)
8-21x	ZS325495	T2BR30x06STL CMT
8-22	SK200918A	TUNING KNOB
8-23x	SK200918B	TUNING KNOB (BL)
8-24	SP200921A	UPPER PLATE (A)
8-25x	SP200921B	UPPER PLATE (A-BL)
8-26x	SP200921C	UPPER PLATE (B) (A)
8-27x	ZS319460	T2BR30x06STL BZN PROJECTION
8-28	ZS322570	ST BID40x08STL NI3
8-29x	ZS322580	ST BID40x08STL BNI
8-30x	SK607127	PUSH KNOB (A) (L)

When ordering parts, please quote Parts Number, Description and Model Number.

II. MODEL AM-U33

1. RECOMMENDED SPARE PARTS

Because, if the parts listed below are on hand, almost any repair can be accomplished, we suggest that you stock these Recommended Spare Parts Items.

REF. NO.	PARTS NO.	DESCRIPTION
1-1	BT300267	△ TRANS POWER AM-U33T-20(A)
1-2	BT300268	△ TRANS POWER AM-U33T-30 (C)
1-3	BT300279	△ TRANS POWER AM-U33T-40 (E)
1-4	BT300280	△ TRANS POWER AM-U33T-50 (B,S)
1-5	BT300346	△ TRANS POWER AM-U33T-70 (U)
1-6	ED322247	D LED SLP-151D RED
1-7	ED322773	D LED SLP-255D-01 GRN
1-8	ED200749	D SILICON DBA60E 400/6.0A
1-9	ED300924	D SILICON GP08D 200/0.8A
1-10	ED200469	D SILICON H DS448 FA1 F10
1-11	ED214457	D SILICON H 1S2472
1-12	ED201445	D ZENER H WZ-187
1-13	ED557111	D ZENER H WZ-210
1-14	EF325683	△ FUSE GGS A 125V 5A (C,A)
1-15	EF668474	△ FUSE SEMKO T 250V 0.40A (E,B,S)
1-16	EF601301	△ FUSE SEMKO T 250V 2A (E,B,S)
1-17	EF249851	△ FUSE SEMKO T 250V 5A (E,B,S)
1-18	EF306950	△ FUSE TSC A 250V 2A (U)
1-19	EF306952	△ FUSE TSC A 250V 4A (U)
1-20	EF308848	△ FUSE TSC 125V 0.40A (C,A)
1-21	EF306957	△ FUSE TSC 125V 4A (C,A)
1-22	EI329612	IC LB1409
1-23	EI200795	IC M5213L
1-24	EI201446	IC M5214L
1-25	EI300349	IC STK2145
1-26	EI323563	IC STK3042
1-27	EI323564	IC TA7317P
1-28	EJ296853	△ SOCKET INLET CM-3 UCEB 3P (E,B,S)
1-29	EJ240535	△ SOCKET OUTLET S-16462 UC 3x2P (U,C,A)
1-30	EJ322582	TERMINAL PUSH S-Q2370 S 4P
1-31	EP323565	RELAY POWER G2Z-222P-US 2NO 24V
1-32	ES310839	△ SW PUSH SDG1P-E 01-1 E (U,E,B,S)
1-33	ES665875	△ SW PUSH SDG1P-J 01-1 UC (C,A)
1-34	ES300347	SW PUSH SUF12 2-02-02S
1-35	ES300443	SW PUSH SUF74 7 THROW
1-36	ET322778	TR 2SA608K-NP E,F,G
1-37	ET322598	TR 2SB632K E,F
1-38	ET307195	TR 2SC2240 GR, BL
1-39	ET310148	TR 2SD612K E,F
1-40	EV315414	R S-FIX H D8 3P 203
1-41	EV324345	VR ROTARY 16P20x1S 15C104
1-42	EV329572	VR ROTARY 16P22x0A 1Z254

3BM254

2. MAIN AMP P.C BOARD BLOCK

REF. NO.	PARTS NO.	DESCRIPTION
2-1	BAA2006A090A	MAIN AMP PC BLK AM-U33
2-IC1	EI323563	IC STK-3042
2-IC2	EI300349	IC STK-2145
2-IC3	EI323564	IC TA7317P
2-TR1	ET307195	TR 2SC2240 GR, BL
2-TR2	ET322778	TR 2SA608K-NP E,F,G
2-TR3	ET310148	△ TR 2SD612K E,F
2-TR4	ET322598	△ TR 2SB632K E,F
2-D1,2	ED200469	D SILICON H DS448 FA1 F10
2-D3,4	ED214457	D SILICON H 1S2472
2-D5	ED200749	△ D SILICON DBA60-K15 400/6.0A
2-D6	ED557111	△ D ZENER H WZ-210
2-D7	ED201445	△ D ZENER H WZ-187
2-VR1	EV315413	R S-FIX H D8 3P 503
2-RL1	EP323565	RELAY POWER G2Z-222P-US 2NO 24V
2-L1	EO324220	COIL FIX 2 2.2μH
2-FR1,2	ER200747	△ R FUSE ERD2FC 1/4W 68R0G
2-FR3,4	ER200746	△ R FUSE ERD2FC 1/4W 1000G
2-R6,7	ER330470	△ R CB H F15 RDS 1/2W 100J
2-R8,9	ER330484	△ R CB H F10 FS RDS 1/4W 272J
2-R27	ER303690	△ R OMF H FS 2W 681J
2-R30,31	ER330471	△ R CB H F15 FS FDS 1/2W 222J
2-R32,33	ER330487	△ R CB H F10 FS RDS 1/4W 4R7J
2-C14,15	EC200949	C EC V F05 NP SM 470M 10DC
2-C18,19	EC326583	C MMY V CUT CF921 473K 400DC
2-C20to23	EC320548	C CE V F 103Z 250AC
2-C24,25	EC200811	C EC V SNP NM 103 50DC
2-C32	EC320548	C CE V F 103Z 250AC

3. PRE AMP (A) P.C BOARD BLOCK

REF. NO.	PARTS NO.	DESCRIPTION
3-1	BAA2006A050A	PC PRE AMP (A) BLK AM-U33(U) (U,E,B,S)
3-2	BAA2006A050B	PC PRE AMP (A) BLK AM-U33 (C) (C,A)
PRE AMP PC BLK		
3-IC1	EI201446	IC M5214L
3-IC2	EI200795	IC M5213L
3-IC3	EI329612	IC LB1409
3-D1	ED300924	Δ D SILICON GP08D 200/0.8A
3-D2	ED200469	Δ D SILICON H DS448 FA1 F10
3-D3	ED200469	D SILICON H DS448 FA1 F10
3-VR1,2	EV324345	VR ROTARY 16P20x1S 15C104
3-VR3	EV315414	R S-FIX H D8 3P 203
3-SW1	ES300443	SW PUSH SUF74 7 THROW
3-R9,10	ER330474	Δ R CB H F10 FS RDS 1/4W 470J
3-R32,33	ER330474	Δ R CB H F10 FS RDS 1/4W 470J
3-R51	ER330485	Δ R CB H F10 FS RDS 1/4W 331J
3-C31	EC320548	C CE V F 103Z 250AC
VOLUME PC BLK		
3-VR1	EV329572	VR ROTARY 16P22x0A 1Z254 3BM254

4. LED (A) P.C BOARD BLOCK

REF. NO.	PARTS NO.	DESCRIPTION
4-D1to9	ED322247	D LED SLP-151D RED

5. LED (B) P.C BOARD BLOCK

REF. NO.	PARTS NO.	DESCRIPTION
5-D1to5	ED322773	D LED SLP-255D-01 GRN

6. HEADPHONE P.C BOARD BLOCK

REF. NO.	PARTS NO.	DESCRIPTION
6-J1	EJ329265	PHONE J 3P HLJ0315-040 6.3 2C
6-R1	ER658034	Δ R OMF H FS 2W 221J

7. RANGE SELECT P.C BOARD BLOCK

REF. NO.	PARTS NO.	DESCRIPTION
7-SW1	ES300347	SW PUSH SUF12 2-02-02S

8. PIN JACK P.C BOARD BLOCK

REF. NO.	PARTS NO.	DESCRIPTION
8-J1103	EJ323144	PIN J T5718-C P 6P
8-C1,2	EC551441	C CE V FZ 103Z 50DC

9. ASSEMBLY BLOCK

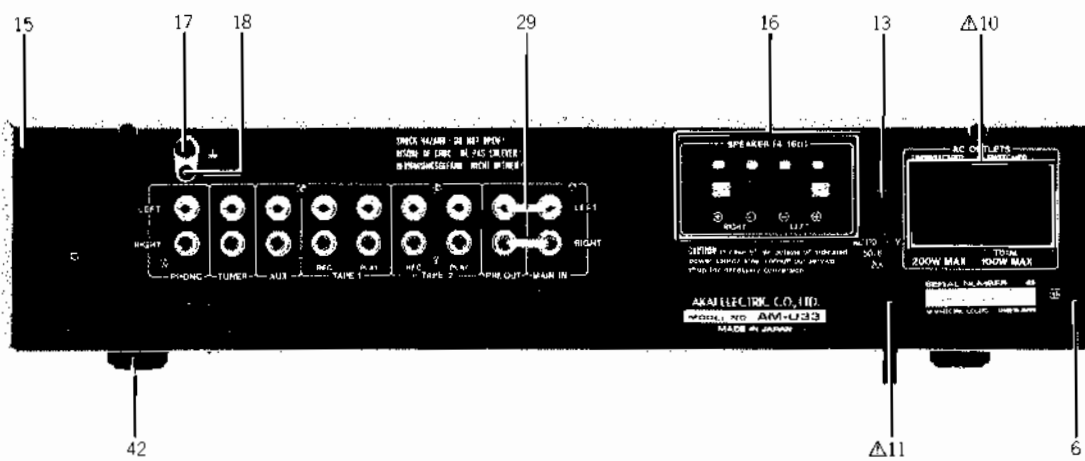
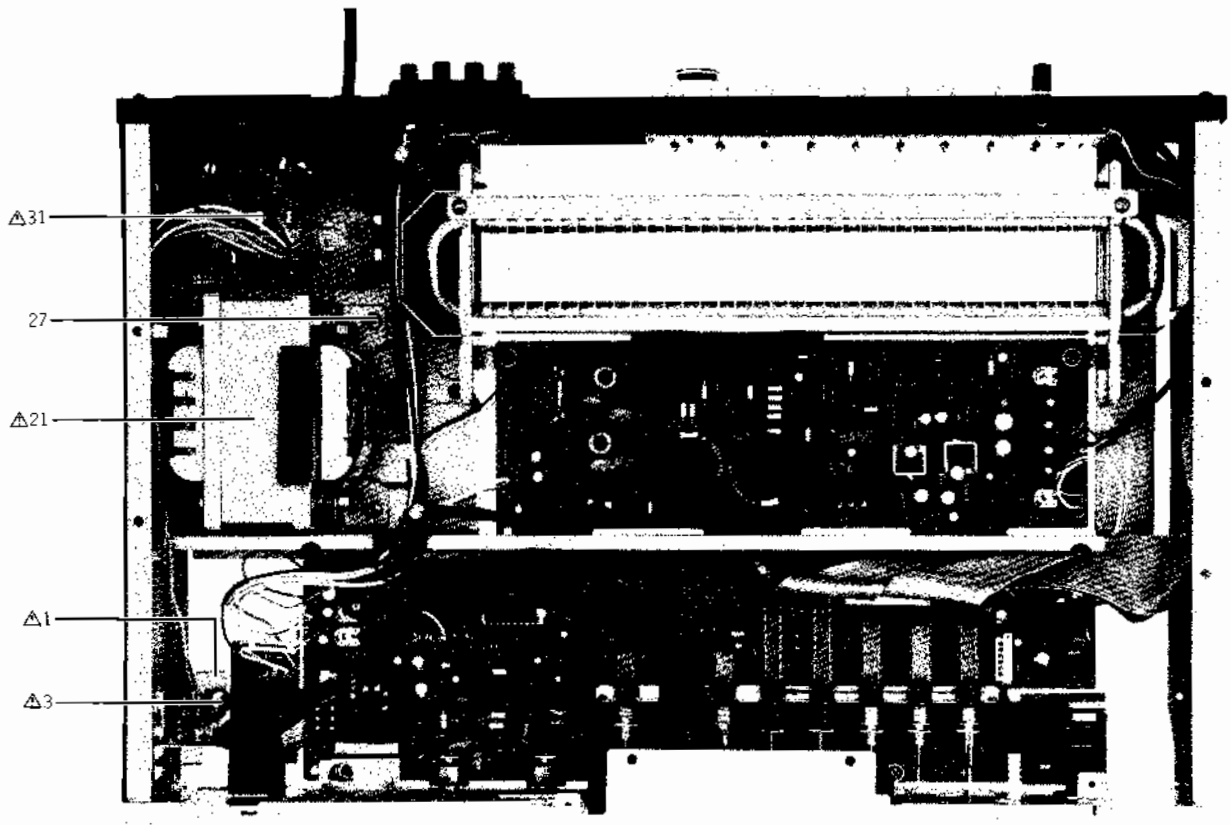

ASSEMBLY BLOCK

REF. NO.	PARTS NO.	DESCRIPTION
9-1	ES310839	△ SW PUSH SDG1P-E 01-1 E (U,E,B,S)
9-2x	ES665875	△ SW PUSH SDG1P-J 01-1 UC (C,A)
9-3	EC320548	△ C CE V F 103Z 250AC (U)
9-4x	EC314688	△ C CE V FZ 103P 125AC (C,A)
9-5x	EC330307	△ C MMY V ECQUF 472M 250AC (E,B,S)
REAR PANEL BLK		
9-6	SP200701B	REAR PANEL AM-U33(U)
9-7x	SP200701C	REAR PANEL AM-U33 (C,A)
9-8x	SP200701D	REAR PANEL AM-U33 (E)
9-9x	SP200701E	REAR PANEL AM-U33 (B,S)
9-10	EJ240535	△ SOCKET OUTLET S-16462 UC 3x2P (U,C,A)
9-11	EW306428	△ AC CORD 2 CORES KP-205A, VFF UCJ (U)
9-12x	EW305691	△ AC CORD 2 CORES KP-8, SPT-1 UC (C,A)
9-13	SZ631945	STRAIN RELIEF SR-4N-4
9-14x	EJ296853	△ SOCKET INLET CM-3 UCEB 3P (E,B,S)
9-15	ZS463353	T2BR30x08STL BNI
9-16	EJ322582	TERMINAL PUSH S-Q2370 S 4P
9-17	EJ329610	TERMINAL W/SCREW UB-0067 L 1P
9-18	ZS319460	T2BR30x06STL BZN PROJECTION
9-19x	ZW305013	RV POP32 (A)
ASSEMBLY BLK		
9-20x	ZS319460	T2BR30x06STL BZN PROJECTION
9-21	BT300346	△ TRANS POWER AM-U33T-70(U)
9-22x	BT300268	△ TRANS POWER AM-U33T-30(C)
9-23x	BT300267	△ TRANS POWER AM-U33T-20(A)
9-24x	BT300279	△ TRANS POWER AM-U33T-40(E)
9-25x	BT300280	△ TRANS POWER AM-U33T-50 (B,S)
9-26x	ZW413267	N FRANGE 40STL CMT
9-27	ZS424056	PAN40x10STL CMT
9-28x	EZ328570	CAP 3P INLET (B)
9-29	EJ326185	PLUG SHORT PIN UZ-0036
9-30x	EF306952	△ FUSE TSC A 250V 4A (F1)(U)
9-31	EF306950	△ FUSE TSC A 250V 2A (F2,3)(U)
9-32x	EF306957	△ FUSE TSC 125V 4A (F1)(C,A)
9-33x	EF325683	△ FUSE GGS A 125V 5A (F2,3)(C,A)
9-34x	EF308848	△ FUSE TSC 125V 0.40A (F4)(C,A)
9-35x	EF601301	△ FUSE SEMKO T 250V 2A (F1)(E,B,S)
9-36x	EF249851	△ FUSE SEMKO T 250V 5A (F2,3)(E,B,S)
9-37x	EF668474	△ FUSE SEMKO T 250V 0.40A (F4)(E,B,S)
9-38x	ZW413267	N FRANGE 40STL CMT
9-39x	SP200714	BOTTOM PLATE
9-40x	ZS325495	T2BR30x06STL CMT
9-41x	ZS447840	T2BR30x08STL CMT
9-42	SA311742	ROUND FOOT
9-43x	ZS565942	T2PAN40x08STL CMT

10. FINAL ASSEMBLY BLOCK

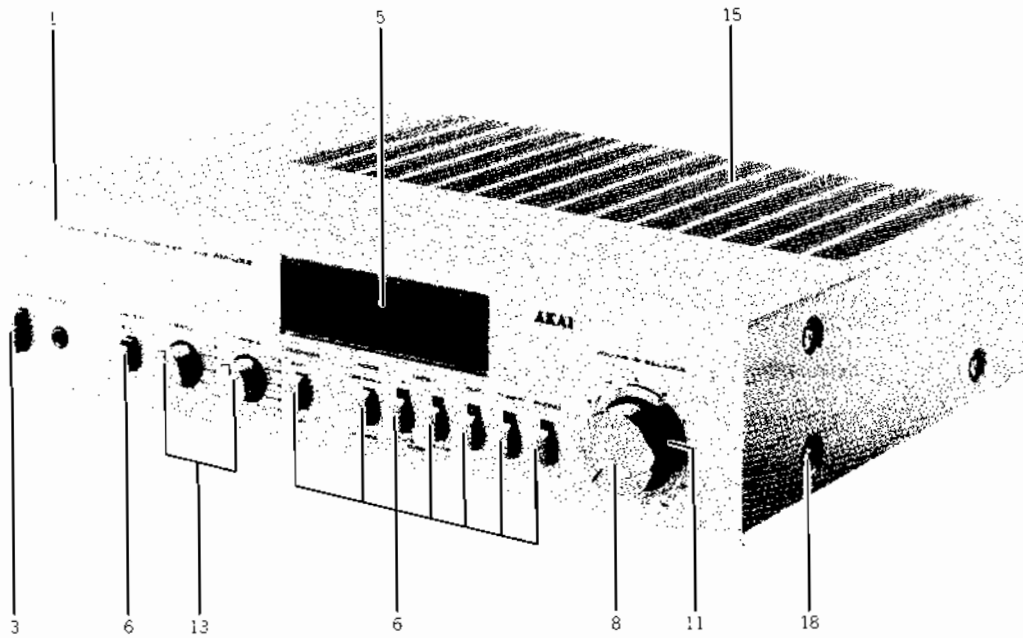

FINAL ASSEMBLY BLOCK

REF. NO.	PARTS NO.	DESCRIPTION
10-1	BDA2006A020A	FRONT PANEL BLK AM-U33
10-2x	BDA2006A020B	FRONT PANEL BLK AM-U33-BL
10-3	SB322576	BUTTON (A)
10-4x	SB322577	BUTTON (A-BL)
10-5	SZ321494	METER WINDOW
FINAL ASSEMBLY BLK		
10-6	SB200915A	BUTTON
10-7x	SB200915B	BUTTON (BL)
10-8	SK200651	DOUBLE KNOB (UPPER-2)
10-9x	SK200652	DOUBLE KNOB (UPPER-2-BL)
10-10x	ZW260144	PW61x100x030NYL
10-11	SK200772A	DOUBLE KNOB (LOWER)
10-12x	SK200772B	DOUBLE KNOB (LOWER-BL)
10-13	SK200645	KNOB (A-2)
10-14x	SK200646	KNOB (A-2-BL)
10-15	SP200717A	UPPER PLATE (A)
10-16x	SP200717B	UPPER PLATE (A-BL)
10-17x	SP200717C	UPPER PLATE (B) (A)
10-18	ZS322570	ST BID40x08STL N13
10-19x	ZS322580	ST BID40x08STL BN1
10-20x	ZS319460	T2BR30x06STL BZN PROJECTION

When ordering parts, please quote Parts Number, Description and Model Number.

III. MODEL AM-U33J

1. RECOMMENDED SPARE PARTS

Because, if the parts listed below are on hand, almost any repair can be accomplished, we suggest that you stock these Recommended Spare Parts Items.

REF. NO.	PARTS NO.	DESCRIPTION
1-1	BT200932	Δ TRANS POWER AM-U33JT-10
1-2	BZA2007A080A	REVERB UNIT BLK AM-U33J
1-3	EC320307	C EC V SNP VN 682 40DC
1-4	ED322247	D LED SLP-151D RED
1-5	ED322773	D LED SLP-255D-01GRN
1-6	ED200213	D SILICON DBA40C-K15 200/2.6A
1-7	ED300924	D SILICON GP08D 200/0.8A
1-8	ED301911	D SILICON H DS448
1-9	ED200469	D SILICON H DS448 FA1 F10
1-10	ED557111	D ZENER H WZ-210
1-11	ED200959	D ZENER H WZ-230
1-12	EF306951	Δ FUSE TSC A 250V 2.5A (F1)
1-13	EF306950	Δ FUSE TSC A 250V 2A (F5,6)
1-14	EF306952	Δ FUSE TSC A 250V 4A (F2,3,4)
1-15	EI697871	IC LA3122S
1-16	EI329612	IC LB1409
1-17	EI329611	IC STK463SLY
1-18	EI200938	IC TA75558S
1-19	EJ330544	PHONO J 3P HLJ0315-010 6.3 2T
1-20	EJ329265	PHONE J 3P HLJ0315-040 6.3 2C
1-21	EJ293365	PIN J T5703-E P 4P
1-22	EJ293376	PIN J T5704-E P 6P
1-23	EJ240535	SOCKET OUTLET S-16462 UC 3x2P
1-24	EJ322582	TERMINAL PUSH S-Q2370 S 4P
1-25	EJ329610	TERMINAL W/SCREW UB-0067 L 1P
1-26	ER329616	R CT P F09 PLATE 3W R47K
1-27	ES315159	Δ SW PUSH SDG1P 01-1 J
1-28	ES200942	SW PUSH SUF64M07A 6 THROW
1-29	ES328851	SW PUSH 12T-9S420 2-02-02N
1-30	ET293220	TR 2SA817 O,Y
1-31	ET293253	TR 2SC1627 O,Y
1-32	ET307195	TR 2SC2240 GR, BL
1-33	EV315416	R S-FIX H D8 3P 103
1-34	EV200936	VR ROTARY 16P10x1B B503
1-35	EV324345	VR ROTARY 16P20x1S 15C104
1-36	EV329572	VR ROTARY 16P22x0A 1Z254 3BM254
1-37	EV200937	VR SLIDE 45P1SV0B B503

2. MAIN AMP P.C BOARD BLOCK

REF. NO.	PARTS NO.	DESCRIPTION
2-1	BAA2007A040A	PC MAIN AMP BLK AM-U33J
MAIN AMP PC BLK		
2-IC1	EI697871	IC LA3122S
2-IC2	EI200938	IC TA75558S
2-IC3	EI329611	Δ IC STK463SLY
2-TR1	ET293253	Δ TR 2SC1627 O,Y
2-TR2	ET293220	Δ TR 2SA817 O,Y
2-D1,2	ED200469	D SILICON H DS448 FA1 F10
2-D3	ED200213	Δ D SILICON DBA40C-K15 200/2.6A
2-D4	ED200959	Δ D ZENER H WZ-230
2-D5	ED557111	Δ D ZENER H WZ-210
2-D6	ED300924	Δ D SILICON GP08D 200/0.8A
2-D7	ED301911	D SILICON H DS448
2-J1	EJ293376	PIN J T5704-E P 6P
2-J2	EJ293365	PIN J T5703-E P 4P
2-SW1	ES200942	SW PUSH SUF64M07A 6 THROW
2-VR1,2	EV324345	VR ROTARY 16P20x1S 15C104
2-L1	EO650823	COIL FIX 2 2.2μH
2-R8	ER330481	Δ R CB H F10 FS RDS 1/4W 220J
2-R17	ER330480	Δ R CB H F10 FS RDS 1/4W 182J
2-R18	ER330477	Δ R CB H F10 FS RDS 1/4W 102J
2-R29	ER330477	Δ R CB H F10 FS RDS 1/4W 102J
2-R30	ER330476	Δ R CB H F10 FS RDS 1/4W 101J
2-R41	ER329616	Δ R CT P F09 PLATE 3W R47K
2-R42	ER330470	Δ R CB H F15 FS RDS 1/2W 100J
2-C19	EC200948	C EC V F05 NP SM 1R0M 50DC
2-C25	EC200949	C EC V F05 NP SM 470M 10DC
2-C35	EC321088	C MMY V CF921 473K 400DC
2-C40,41	EC320307	C EC V SNP VN 682 40DC
2-C50	EC320548	C CE V F 103Z 250AC
VR PC BLK		
2-VR1	EV329572	VR ROTARY 16P22x0A 1Z254 3BM254
HEADPHONE PC BLK		
2-J1	EJ329265	PHONE J 3P HLJ0315-040 6.3 2C
2-SW1	ES328851	SW PUSH 12T-9S420 2-02-02N
2-R1	ER308028	R OMF H SNP FS 1W 181J

3. MIC AMP P.C BOARD BLOCK

REF. NO.	PARTS NO.	DESCRIPTION
MIC AMP PC BLK		
3-IC1	EI200938	IC TA75558S
3-TR1	ET307195	TR 2SC2240 GR, BL
3-TR2	ET293253	TR 2SC1627 O, Y
3-TR3	ET307195	TR 2SC2240 GR, BL
3-VR1	EV200937	VR SLIDE 45P1SV0B B503
3-R11	ER330486	R CB H F10 FS RDS 1/4W 391J
3-R12	ER330483	R CB H F10 FS RDS 1/4W 271J
MIC JACK PC BLK		
3-J1	EJ330544	PHONE J 3P HLJ0315-010 6.3 2T
ECHO VOLUME PC BLK		
3-VR1	EV200936	VR ROTARY 16P10x1B B503

4. LED (B) P.C BOARD BLOCK

REF. NO.	PARTS NO.	DESCRIPTION
4-IC1	EI329612	IC LB1409
4-D1,2	ED200469	D SILICON H DS448 FA1 F10
4-D3to11	ED322247	D LED SLP-151D RED
4-VR1	EV315416	R S-FIX H D8 3P 103
4-R17	ER330479	Δ R CB H F10 FS RDS 1/4W 181J

ASSEMBLY BLOCK

REF. NO.	PARTS NO.	DESCRIPTION
REVEB UNIT BLK		
5-1	BZA2007A080A	REVERB UNIT BLK AM-U33J
POWER SW BLK		
5-2	ES315159	Δ SW PUSH SDG1P 01-1 J
5-3	EC320548	Δ C CE V F 103Z 250AC
REAR PANEL BLK		
5-4	SP200850	REAR PANEL AM-U33J
5-5	EJ240535	Δ SOCKET OUTLET S-16462 UC 3x2P
5-6	EJ322582	TERMINAL PUSH S-Q2370 S 4P
5-7	EW306427	Δ AC CORD 2 CORES KP-211, VFF J
5-8	SZ631945	STRAIN RELIEF SR-4N-4
5-9	EJ329610	TERMINAL W/SCREW UB-0067 L 1P
5-10	ZS319460	T2BR30x06STL BZN PROJECTION
ASSEMBLY BLK		
5-11	BT200932	Δ TRANS POWER AM-U33JT-10
5-12	ZW413267	N FRANGE 40STL CMT
5-13	ZS424056	PAN40x10STL CMT
5-14x	ZS325495	T2BR30x06STL CMT
5-15x	SZ200770A	MASK
5-16x	SZ200770B	MASK (BL)
5-17x	SP200752	BOTTOM PLATE
5-18x	ZS325495	T2BR30x06STL CMT
5-19x	ZS447840	T2BR30x08STL CMT
5-20	SA311742	ROUND FOOT
5-21x	ZS65942	T2PAN40x08STL CMT
5-22	EF306951	Δ FUSE TSC A 250V 2.5A (F1)
5-23	EF306952	Δ FUSE TSC A 250V 4A (F2,3,4)
5-24	EF306950	Δ FUSE TSC A 250V 2A (F5,6)

When ordering parts, please quote Parts Number, Description and Model Number.

5. ASSEMBLY BLOCK

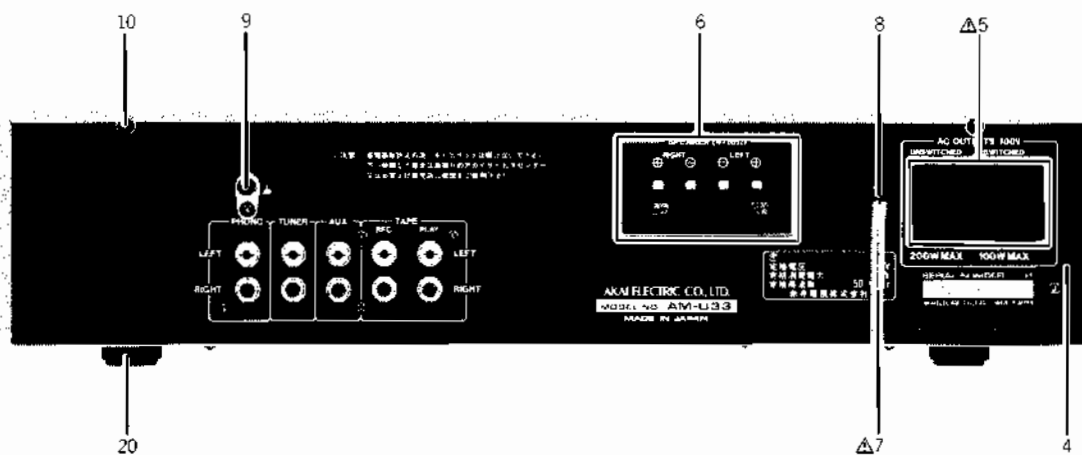
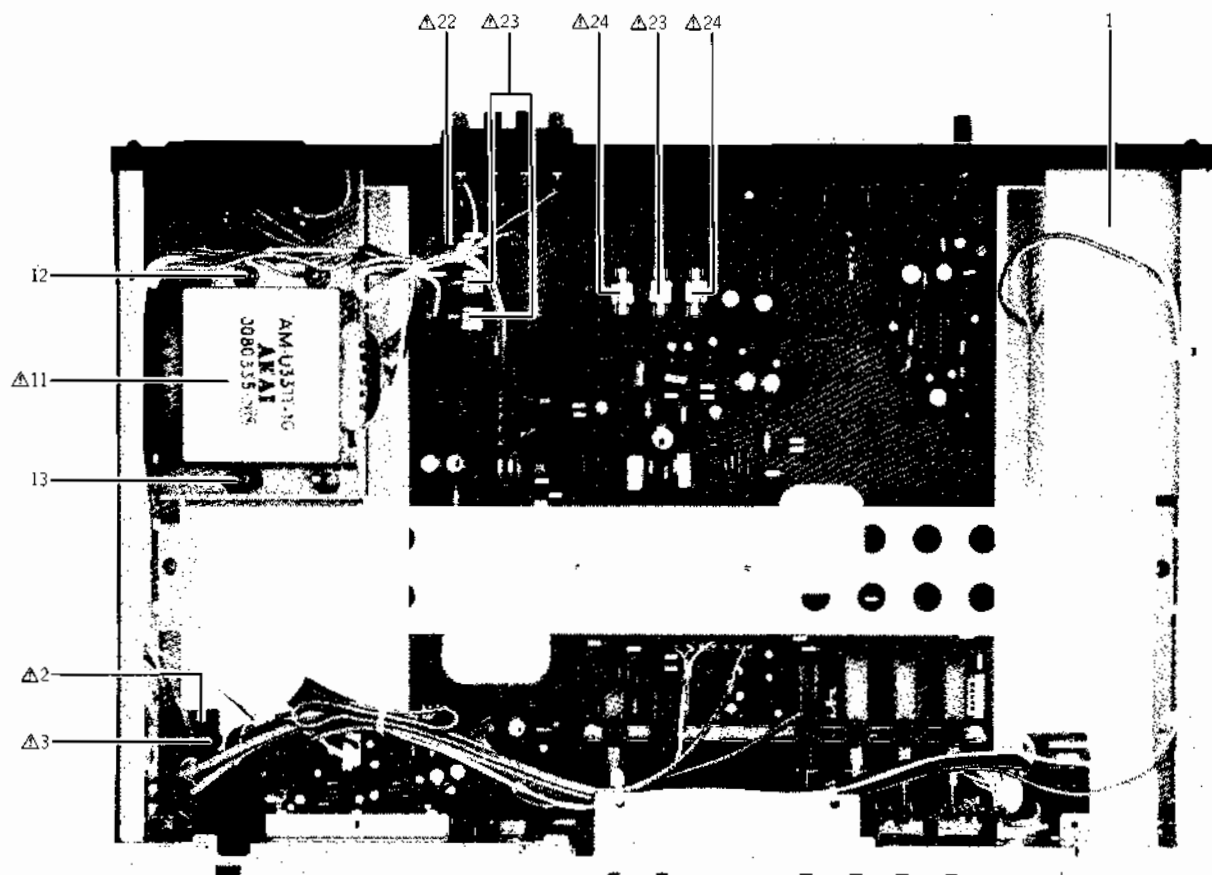

6. FINAL ASSEMBLY BLOCK

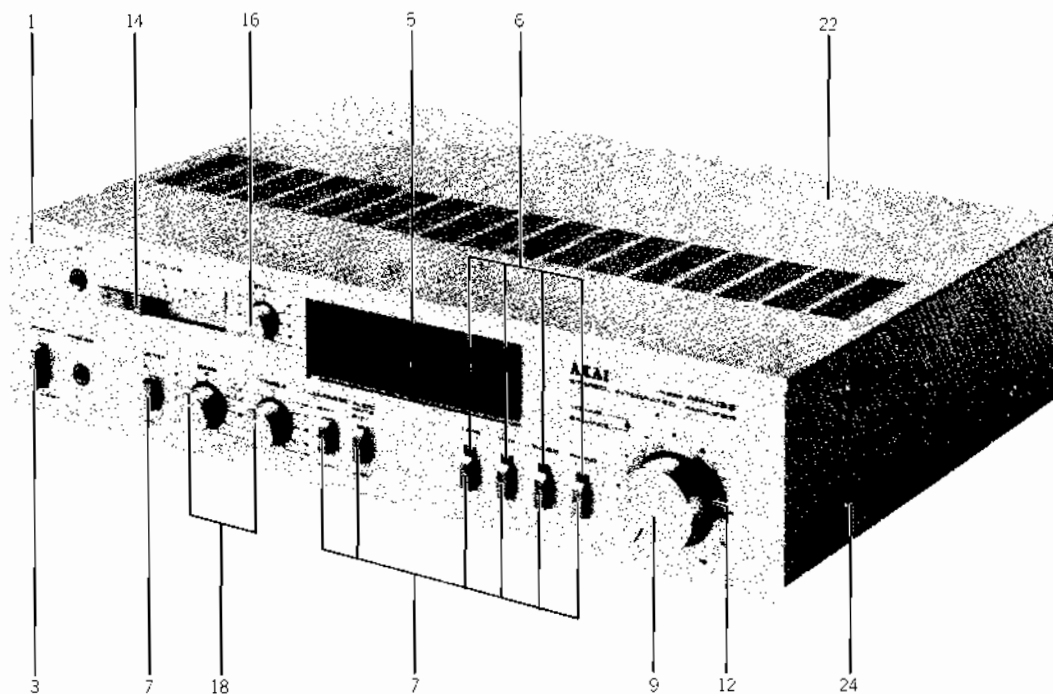

FINAL ASSEMBLY BLOCK

REF. NO.	PARTS NO.	DESCRIPTION
FRONT PANEL BLK		
6-1	BDA2007A130A	FRONT PANEL BLK AM-U33J
6-2x	BDA2007A130B	FRONT PANEL BLK AM-U33J-BL
6-3	SB322576	BUTTON (A)
6-4x	SB322577	BUTTON (A-BL)
6-5	SZ321494	METER WINDOW
LED (A) PC BLK		
6-6	ED322773	D LED SLP-255D-01 GRN
FINAL ASSEMBLY BLK		
6-7	SB200915A	BUTTON
6-8x	SB200915B	BUTTON (BL)
6-9	SK200651	DOUBLE KNOB (UPPER-2)
6-10x	SK200652	DOUBLE KNOB (UPPER-2-BL)
6-11x	ZW260144	PW61x100x030NYL
6-12	SK200772A	DOUBLE KNOB (LOWER)
6-13x	SK200772B	DOUBLE KNOB (LOWER-BL)
6-14	SK200647	KNOB (A-2)
6-15x	SK200648	KNOB (A-2-BL)
6-16	SK200778A	KNOB
6-17x	SK200778B	KNOB (BL)
6-18	SK200645	KNOB (A-2)
6-19x	SK200646	KNOB (A-2-BL)
6-20x	SZ316376	KNOB CUSHION (A)
6-21x	SZ316377	KNOB CUSHION (B)
6-22	SP200774A	UPPER PLATE (A)
6-23x	SP200774B	UPPER PLATE (A-BL)
6-24	ZS322570	ST BID40x08STL NI3
6-25x	ZS322580	ST BID40x08STL BNI
6-26x	ZS319460	T2BR30x06STL BZN PROJECTION

When ordering parts, please quote Parts Number, Description and Model Number.

INDEX

1. MODEL AT-K33/L/J

PARTS NO.	REF. NO.	PARTS NO.	REF. NO.	PARTS NO.	REF. NO.	PARTS NO.	REF. NO.
BAA3010A050A	2-2	ED323216	2-D9	ER324337	2-R13,14	SE201787B	8-13x
BAA3010A070A	3-2	ED325080	3-D3	ER324337	2-R65,66	SK200918A	8-22
BAA3010C020A	2-1	EE200184	7-15	ER324480	2-R97,98	SK200918B	8-23x
BAA3010C020B	2-3	EE200810	7-16x	ER328855	2-FL3,4	SK607127	8-30x
BAA3010C020C	2-4	EE200954	2-7	ES200829	2-SW3	SP200689A	7-8x
BAA3010C050A	3-1	EE325737	2-6	ES200955	5-SW1	SP200689B	7-7
BAA3010E030A	2-5	EF300590	7-39x	ES201948	2-SW2	SP200689C	7-9x
BDA3010A020C	8-1	EF308848	7-38x	ES201979	2-SW1	SP200689D	7-10x
BDA3010A020D	8-2x	EF308933	7-37	ES310839	7-1	SP200689E	7-11x
BDA3010A100A	8-3x	EF309389	7-36x	ES315159	7-2x	SP200689F	7-12x
BDA3010A100B	8-4x	EI293185	2-IC3	ES319168	6-SW1	SP200689G	7-13x
BDA3010E020A	8-5x	EI315491	2-IC4	ES328851	2-SW1	SP200689H	7-14x
BDA3010E020B	8-6x	EI322248	2-IC1	ES665875	7-3x	SP200694	7-40x
BT200953	7-25x	EI323231	3-X1	ET200506	2-TR5,6	SP200921A	8-24
BT238844	7-27x	EI323247	2-IC1	ET316171	3-TR2	SP200921B	8-25x
BT328842	7-24	EI323247	5-IC1	ET316643	2-TR2to4	SP200921C	8-26x
BT328843	7-26x	EI328849	3-IC1	ET316643	2-TR7to9	SP201792A	8-8
BT328845	7-28x	EI328850	3-IC2	ET316643	2-TR11	SP201792B	8-11x
EC201253	2-C68	EI650597	2-IC2	ET316643	5-TR1	SP201792C	8-9x
EC314688	7-5x	EJ301513	7-21x	ET323232	2-TR10	SP201792D	8-12x
EC314996	2-C59	EJ309941	2-TM1	ET618873	2-TR1	SZ321494	8-16
EC320548	2-C84,85	EJ323227	2-J1	ET618873	3-TR1	SZ631945	7-20
EC320548	2-C87	EM328848	3-IN1	EV323213	5-VR1	TA200910	8-7x
EC320548	7-4	EO201252	2-T5	EV427858	2-VR3	TA200911A	8-14x
EC328856	2-C76,77	EO307186	2-T4	EV499375	2-VR4	TA200911B	8-15x
EC328862	2-C33	EO324453	6-T1	EV593368	2-VR1,2	TA307160	7-35
EC330307	7-6x	EO328137	2-L1,2	EV604438	3-VR1,2	TA322250	7-34
EC616342	2-VC1,2	EO328137	3-L1to3	EW302995	7-46x	TA328846	7-31
EC616342	2-VC3	EO328854	2-T1	EW305691	7-19x	ZS315511	7-29
EC616342	6-VC1,2	EO485278	6-L1	EW306427	7-18x	ZS319460	7-22
ED200469	2-D1	ER293398	2-T2	EW306428	7-17	ZS319460	8-27x
ED200469	2-D1to8	ER307201	2-FL1,2	EW315767	7-45x	ZS322570	8-28
ED200469	3-D1,2	ER307204	2-T3	EW322401	7-47x	ZS322580	8-29x
ED200469	5-D1	ER324185	2-R85	MR308836	7-23	ZS325495	8-21x
ED224526	2-D11	ER324185	3-R35	SA311742	7-41x	ZS447840	7-43x
ED309959	3-D4	ER324186	3-R38	SB200915A	8-19	ZS463094	7-42x
ED322184	4-D3	ER324337	2-R7,8	SB200915B	8-20x	ZW305013	7-44x
ED322215	4-D2	ER324337	2-R73to75	SB316498	8-17	ZW436026	7-32x
ED322238	2-D10	ER324337	2-R31,32	SB316499	8-18x	ZW554624	7-33
ED322247	4-D1	ER324337	2-R56,57	SE201787A	8-10x	ZW698308	7-30x

2. MODEL AM-U33

PARTS NO.	REF. NO.	PARTS NO.	REF. NO.	PARTS NO.	REF. NO.	PARTS NO.	REF. NO.
BAA2006A050A	3-1	EF249851	9-36x	ER330484	2-R8,9	SP200701B	9-6
BAA2006A050B	3-2	EF306950	9-31	ER330485	3-R51	SP200701C	9-7x
BAA2006A090A	2-1	EF306952	9-30x	ER330487	2-R32,33	SP200701D	9-8x
BDA2006A020A	10-1	EF306957	9-32x	ER658034	6-R1	SP200701E	9-9x
BDA2006A020B	10-2x	EF308848	9-34x	ES300347	7-SW1	SP200714	9-39x
BT300267	9-23x	EF325683	9-33x	ES300443	3-SW1	SP200717A	10-15
BT300268	9-22x	EF601301	9-35x	ES310839	9-1	SP200717B	10-16x
BT300279	9-24x	EF668474	9-37x	ES665875	9-2x	SP200717C	10-17x
BT300280	9-25x	EI200795	3-IC2	ET307195	2-TR1	SZ321494	10-5
BT300346	9-21	EI201446	3-IC1	ET310148	2-TR3	SZ631945	9-13
EC200811	2-C24,25	EI300349	2-IC2	ET322598	2-TR4	ZS319460	9-18
EC200949	2-C14,15	EI323563	2-IC1	ET322778	2-TR2	ZS319460	9-20x
EC314688	9-4x	EI323564	2-IC3	EV315413	2-VR1	ZS319460	10-20x
EC320548	2-C20to23	EI329612	3-IC3	EV315414	3-VR3	ZS322570	10-18
EC320548	2-C32	EJ240535	9-10	EV324345	3-VR1,2	ZS322580	10-19x
EC320548	3-C31	EJ296853	9-14x	EV329572	3-VR1	ZS325495	9-40x
EC320548	9-3	EJ322582	9-16	EW305691	9-12x	ZS424056	9-27
EC326583	2-C18,19	EJ323144	8-J1to3	EW306428	9-11	ZS447840	9-41x
EC330307	9-5x	EJ326185	9-29	EZ328570	9-28x	ZS463353	9-15
EC551441	8-C1,2	EJ329265	6-J1	SA311742	9-42	ZS565942	9-43x
ED200469	2-D1,2	EJ329610	9-17	SB200915A	10-6	ZW260144	10-10x
ED200469	3-D2	EO324220	2-L1	SB200915B	10-7x	ZW305013	9-19x
ED200469	3-D3	EP323565	2-RL1	SB322576	10-3	ZW413267	9-26x
ED200749	2-D5	ER200746	2-FR3,4	SB322577	10-4x	ZW413267	9-38x
ED201445	2-D7	ER200747	2-FR1,2	SK200645	10-13		
ED214457	2-D3,4	ER303690	2-R27	SK200646	10-14x		
ED300924	3-D1	ER330470	2-R6,7	SK200651	10-8		
ED322247	4-D1to9	ER330471	2-R30,31	SK200652	10-9x		
ED322773	5-D1to5	ER330474	3-R9,10	SK200772A	10-11		
ED557111	2-D6	ER330474	3-R32,33	SK200772B	10-12x		

INDEX

3. MODEL AM-U33J

PARTS NO.	REF. NO.	PARTS NO.	REF. NO.	PARTS NO.	REF. NO.	PARTS NO.	REF. NO.
BAA2007A040A	2-1	EJ293376	2-J1	EW306427	5-7	ZS325495	5-14x
BDA2007A130A	6-1	EJ322582	5-6	SA311742	5-20	ZS325495	5-18x
BDA2007A130B	6-2x	EJ329265	2-J1	SB200915A	6-7	ZS424056	5-13
BT200932	5-11	EJ329610	5-9	SB200915B	6-8x	ZS447840	5-19x
BZA2007A080A	5-1	EJ330544	3-J1	SB322576	6-3	ZS565942	5-21x
EC200948	2-C19	EO650823	2-L1	SB322577	6-4x	ZW260144	6-11x
EC200949	2-C25	ER308028	2-R1	SK200645	6-18	ZW413267	5-12
EC320307	2-C40,41	ER329616	2-R41	SK200646	6-19x		
EC320548	2-C50	ER330470	2-R42	SK200647	6-14		
EC320548	5-3	ER330476	2-R30	SK200648	6-15x		
EC321088	2-C35	ER330477	2-R18	SK200651	6-9		
ED200213	2-D3	ER330477	2-R29	SK200652	6-10x		
ED200469	2-D1,2	ER330479	4-R17	SK200772A	6-12		
ED200469	4-D1,2	ER330480	2-R17	SK200772B	6-13x		
ED200959	2-D4	ER330481	2-R8	SK200778A	6-16		
ED300924	2-D6	ER330483	3-R12	SK200778B	6-17x		
ED301911	2-D7	ER330486	3-R11	SP200752	5-17x		
ED322247	4-D3to11	ES200942	2-SW1	SP200774A	6-22		
ED322773	6-6	ES315159	5-2	SP200774B	6-23x		
ED557111	2-D5	ES328851	2-SW1	SP200850	5-4		
EF306950	5-24	ET293220	2-TR2	SZ200770A	5-15x		
EF306951	5-22	ET293253	2-TR1	SZ200770B	5-16x		
EF306952	5-23	ET293253	3-TR2	SZ316376	6-20x		
EI200938	2-IC2	ET307195	3-TR1	SZ316377	6-21x		
EI200938	3-IC1	ET307195	3-TR3	SZ321494	6-5		
EI329611	2-IC3	EV200936	3-VR1	SZ631945	5-8		
EI329612	4-IC1	EV200937	3-VR1	ZS319460	5-10		
EI697871	2-IC1	EV315416	4-VR1	ZS319460	6-26x		
EJ240535	5-5	EV324345	2-VR1,2	ZS322570	6-24x		
EJ293365	2-J2	EV329572	2-VR1	ZS322580	6-25x		

SECTION 5

SCHEMATIC DIAGRAM

1. SCHEMATIC DIAGRAM OF ICs
2. AT-K33 NO. 1621058A SCHEMATIC DIAGRAM
3. AT-K33J NO. 1621059A SCHEMATIC DIAGRAM
4. AT-K33L NO. 1621060A SCHEMATIC DIAGRAM
5. AM-U33 NO. 1621061A SCHEMATIC DIAGRAM
6. AM-U33J NO. 1621062A SCHEMATIC DIAGRAM

LA1231N

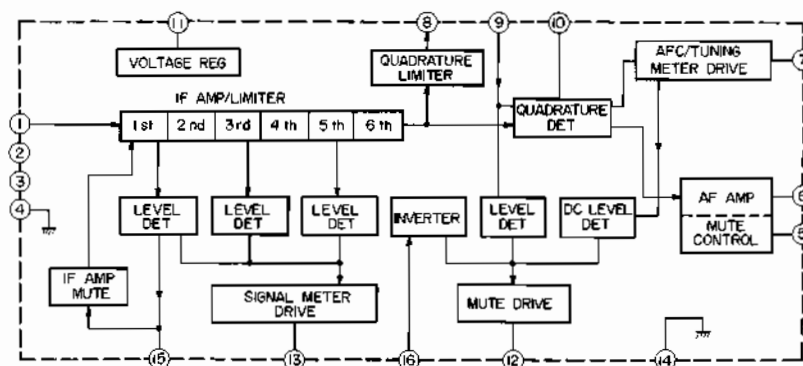

LA3350S

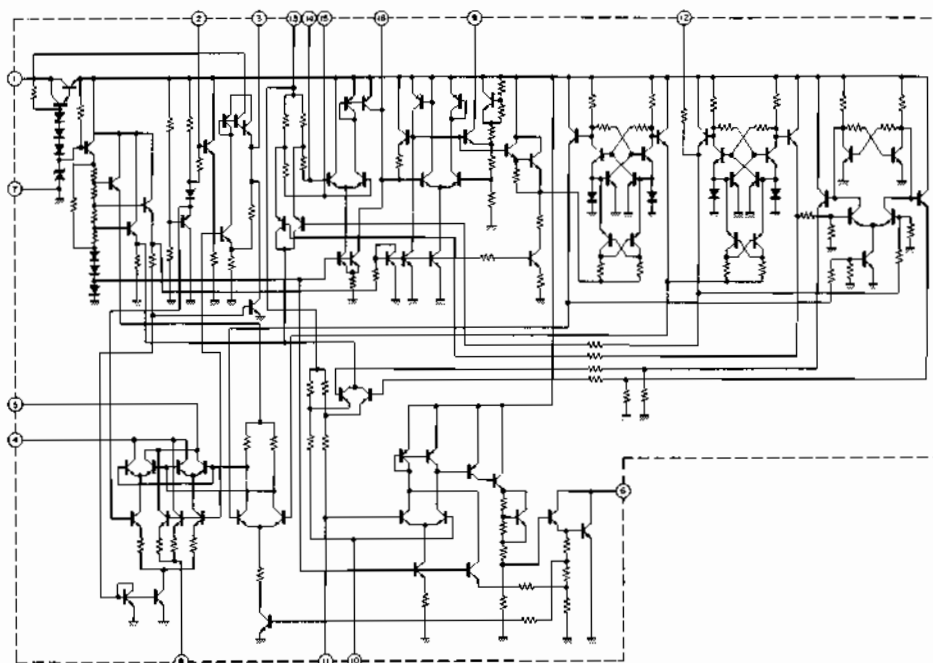

LA1240

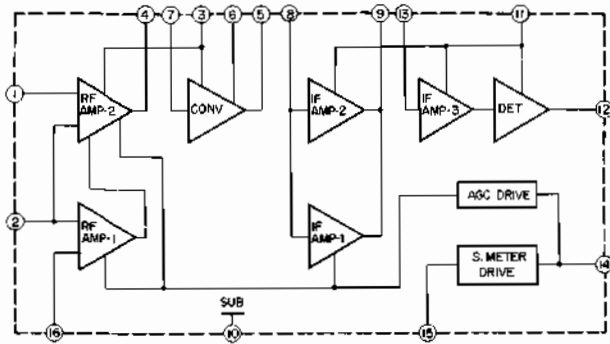

LA3122S

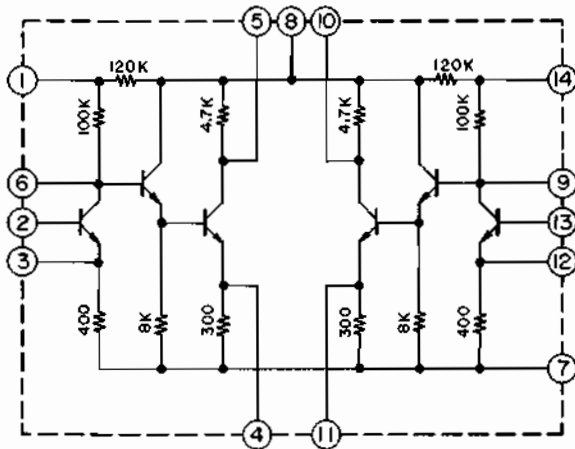

LB1405S

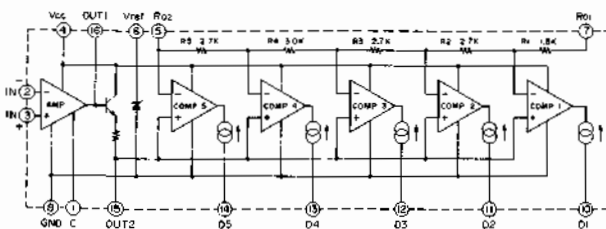

LB1409

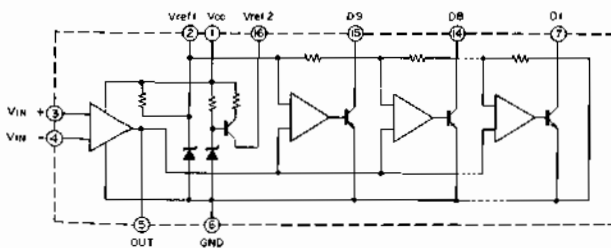

LC7259

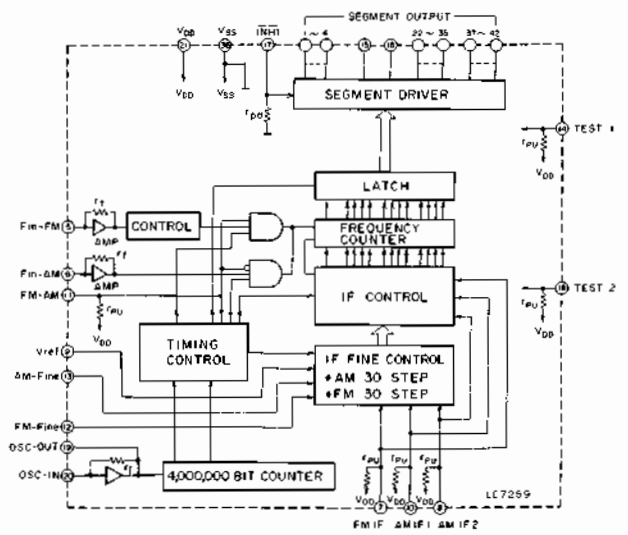

NOTE: rPU is a special-type resistor which resistance will become the rated value at "H" level, and high at "L" level.

M5213L

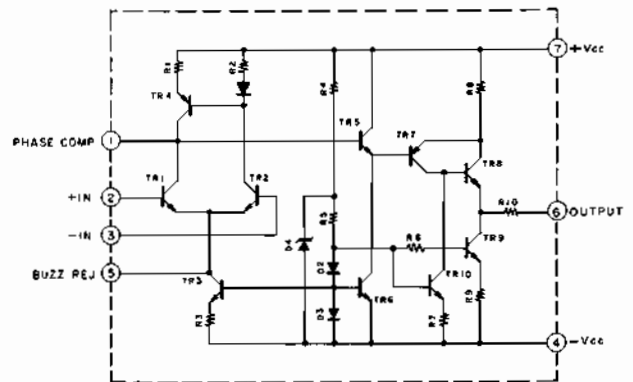

M5214L

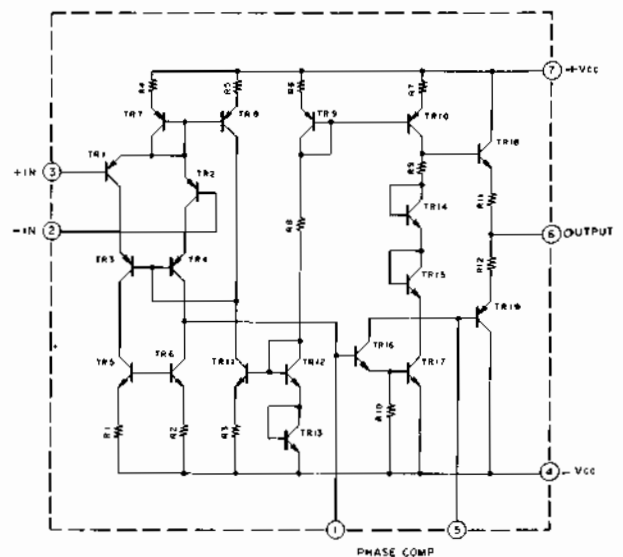

M54459L

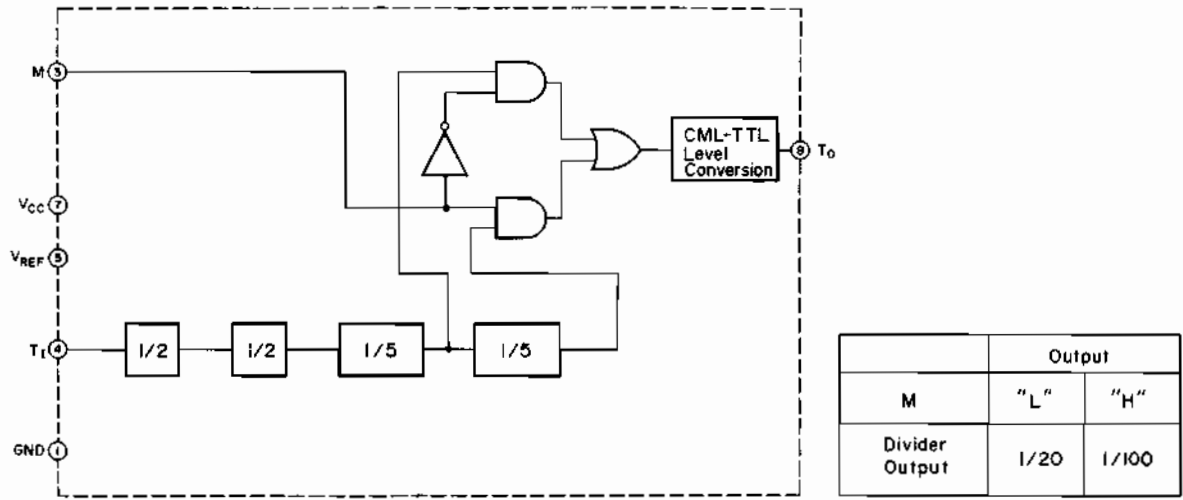

STK2145

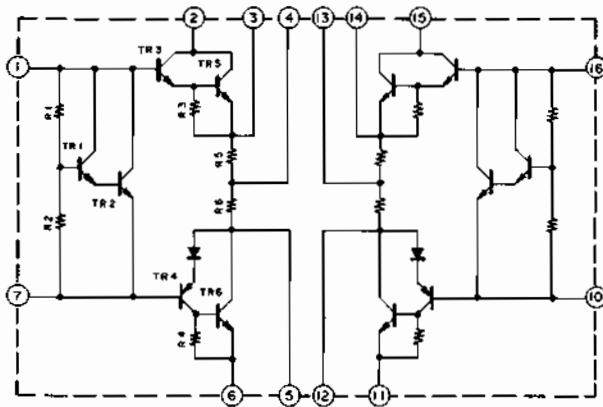

STK-463SLY

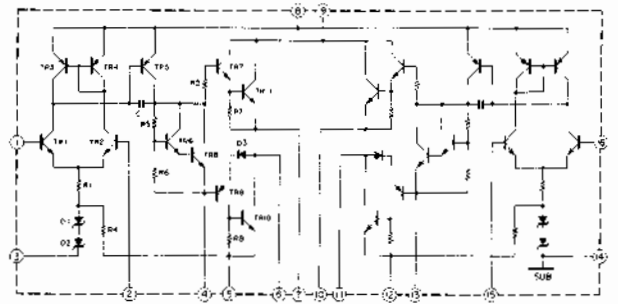

STK3042

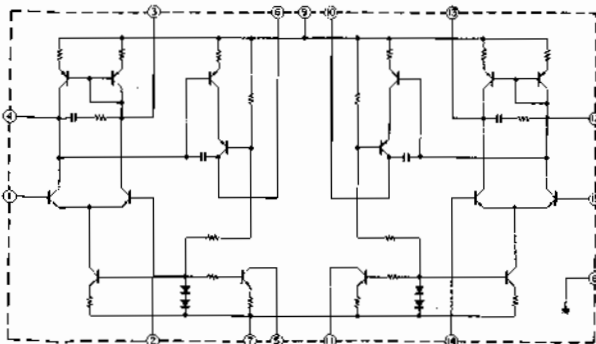

TA7324P

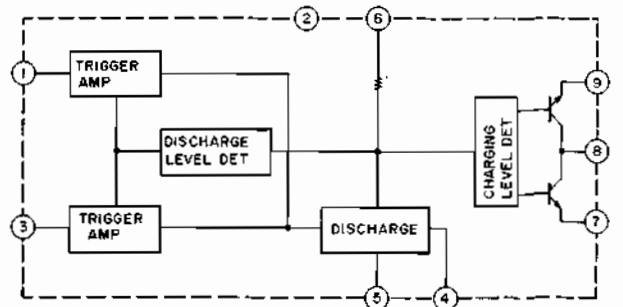

TA7317P

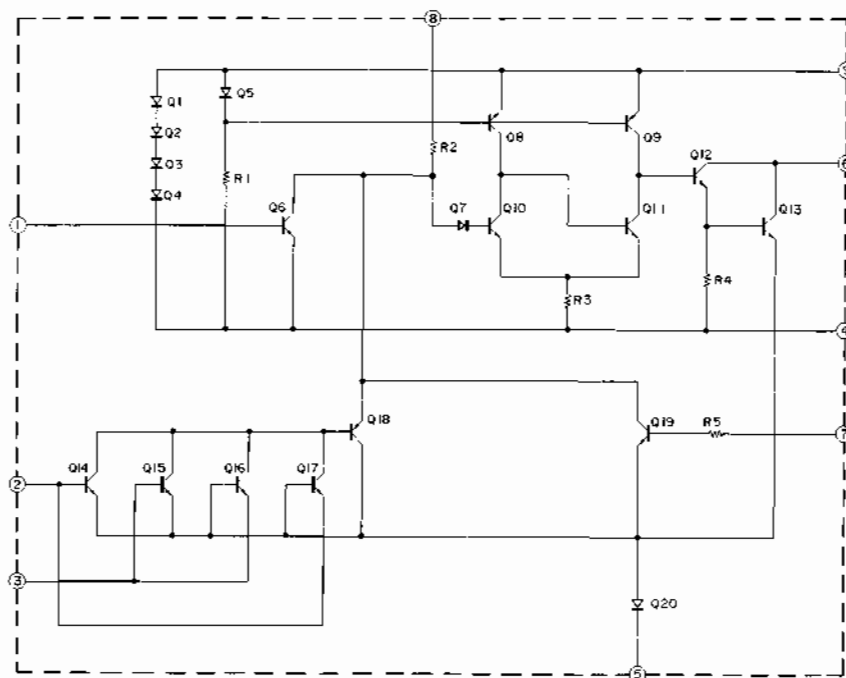
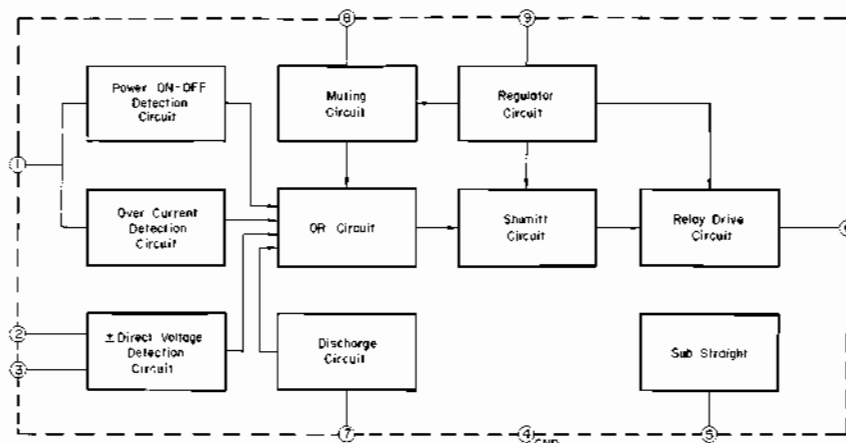

TA75558S

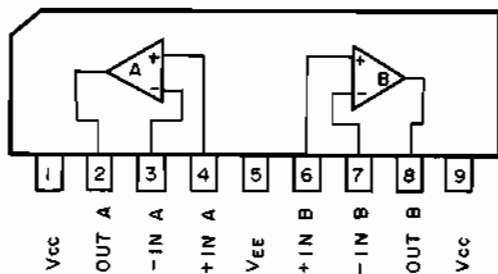

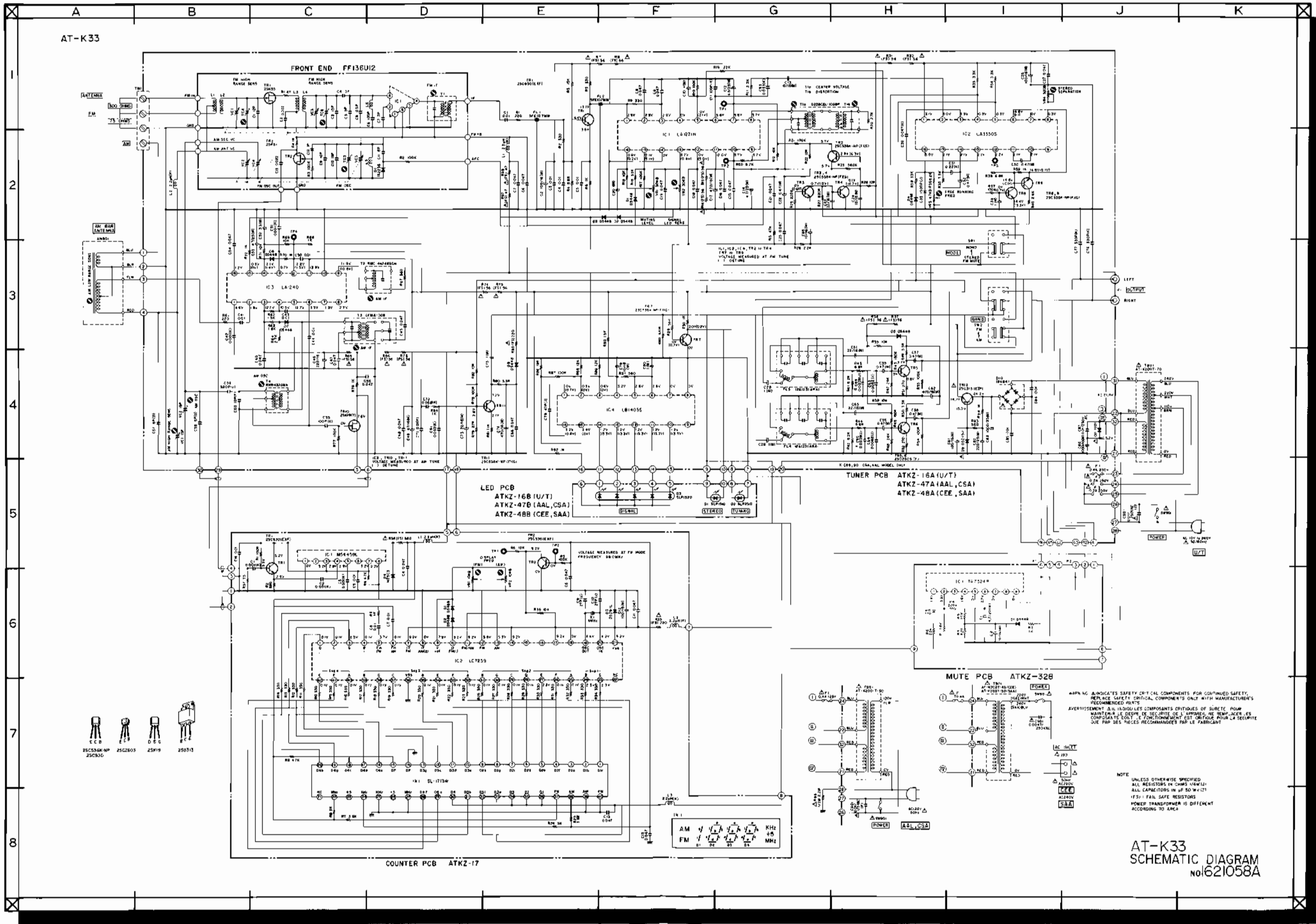

AT-K33

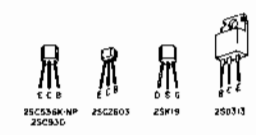

LED PCB
ATKZ-16B (U/T)
ATKZ-47B (AAL, CSA)
ATKZ-48B (CEE, SAA)

TUNER PCB
ATKZ-16A (U/T)
ATKZ-47A (AAL, CSA)
ATKZ-48A (CEE, SAA)

MUTE PCB ATKZ-32B

▲ SPC AND ▲ INDICATES SAFETY CRITICAL COMPONENTS FOR CONTINUED SAFETY.
REPLACE SAFETY CRITICAL COMPONENTS ONLY WITH MANUFACTURER'S
RECOMMENDED PARTS.
AVERTISSEMENT: ▲ SPC ET ▲ INDICQUE LES COMPOSANTS CRITIQUES DE SURETE POUR
MAINTENIR LE DEGRE DE SECURITE DE L'APPAREIL. NE REMPLACEZ
COMPOSANTS SPC ET ▲ FONCTIONNEMENT EST CRITIQUE POUR LA SECURITE
DE PAR DES RECES RECOMMANDES PAR LE FABRICANT.

NOTE
UNLESS OTHERWISE SPECIFIED:
ALL RESISTORS IN OHMS UNLESS
ALL CAPACITORS IN µF 50V-127V
F50: FAIL SAFE RESISTORS
POWER TRANSFORMER IS DIFFERENT
ACCORDING TO AREA

AT-K33
SCHEMATIC DIAGRAM
No. 621058A

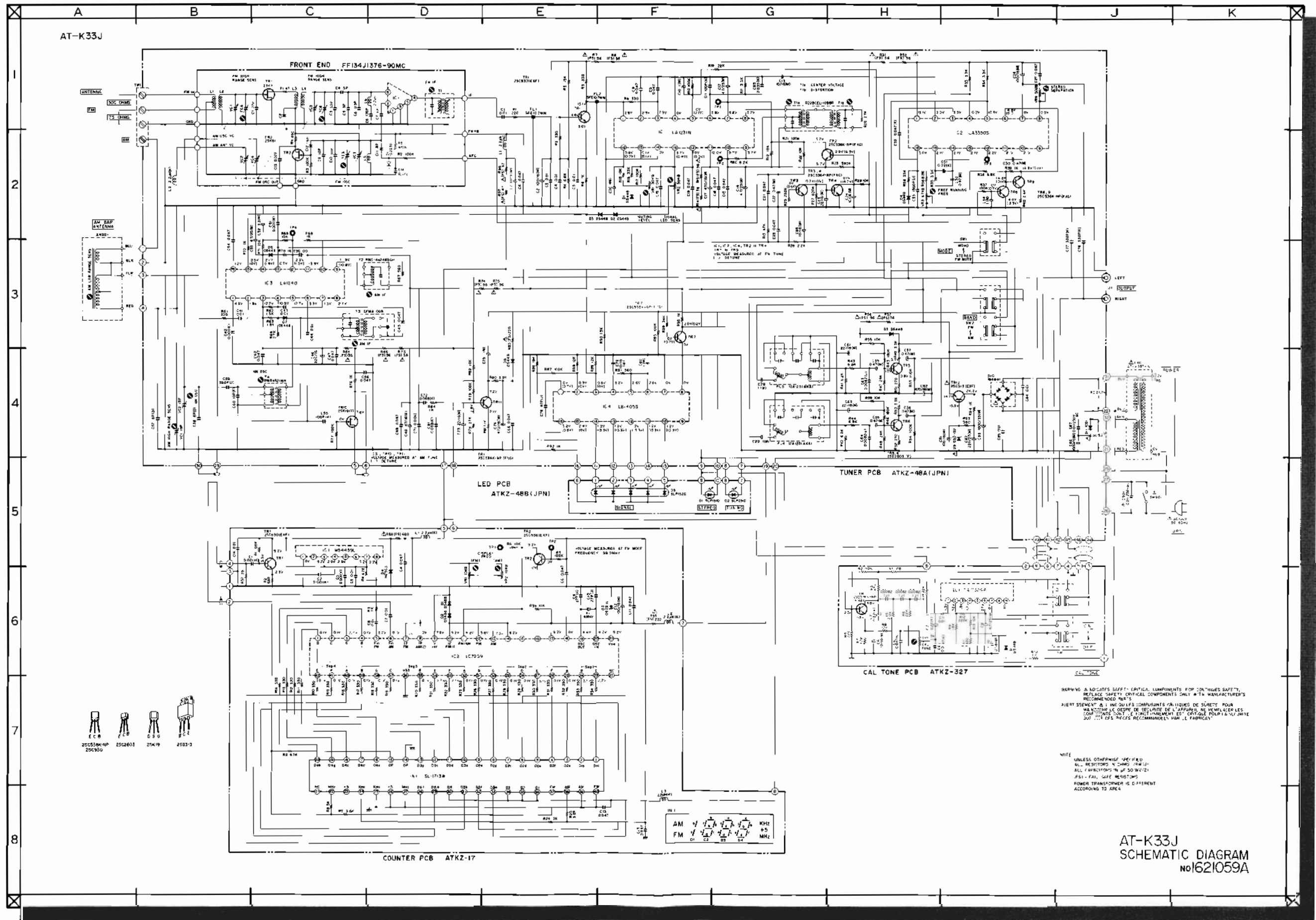

WARNING & INDICATES SAFETY CRITICAL COMPONENTS FOR CONTINUED SAFETY.
 REPLACE SAFETY CRITICAL COMPONENTS ONLY WITH MANUFACTURER'S
 RECOMMENDED PARTS.
 AVERTISSEMENT & : INDICATE LES COMPOSANTS CRITIQUES DE SURETE POUR
 MAINTENIR LE DEGRE DE SECURITE DE L'APPAREIL. NE REMPLACEZ LES
 COMPOSANTS CRITIQUES QUE PAR LES RECOMMANDES PAR LE FABRICANT.

NOTE
 UNLESS OTHERWISE SPECIFIED:
 ALL RESISTORS IN OHMS UNLESS
 ALL CAPACITORS IN P.F. UNLESS
 P.F. = P.F., SAFE RESISTORS
 POWER TRANSFORMER IS EFFICIENT
 ACCORDING TO AREA

AT-K33J
 SCHEMATIC DIAGRAM
 no1621059A

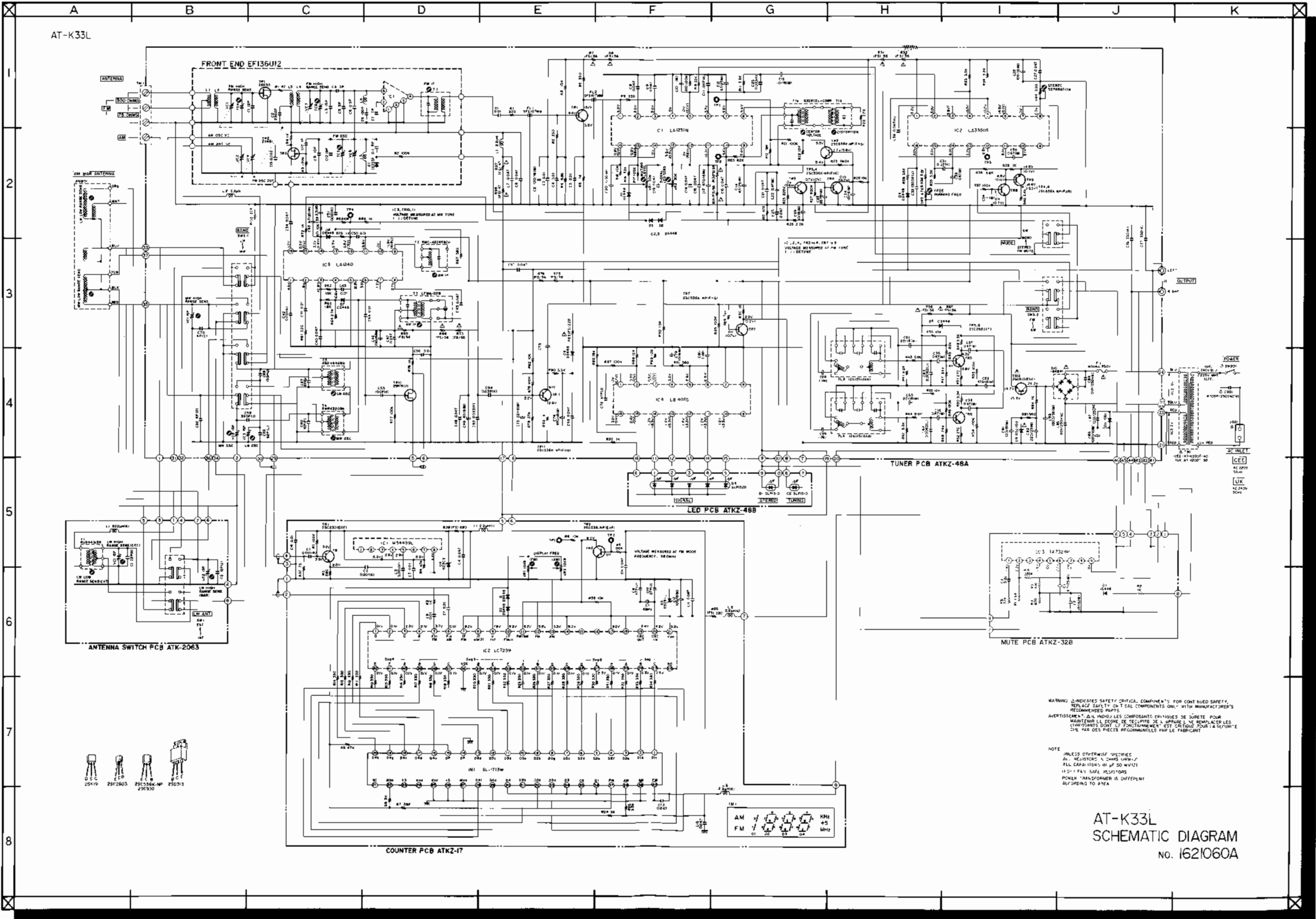

AT-K33L

1
2
3
4
5
6
7
8

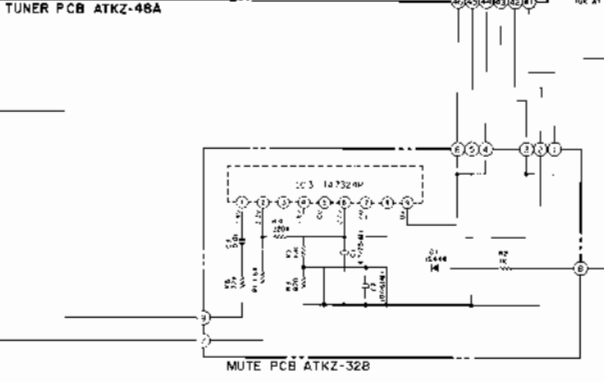
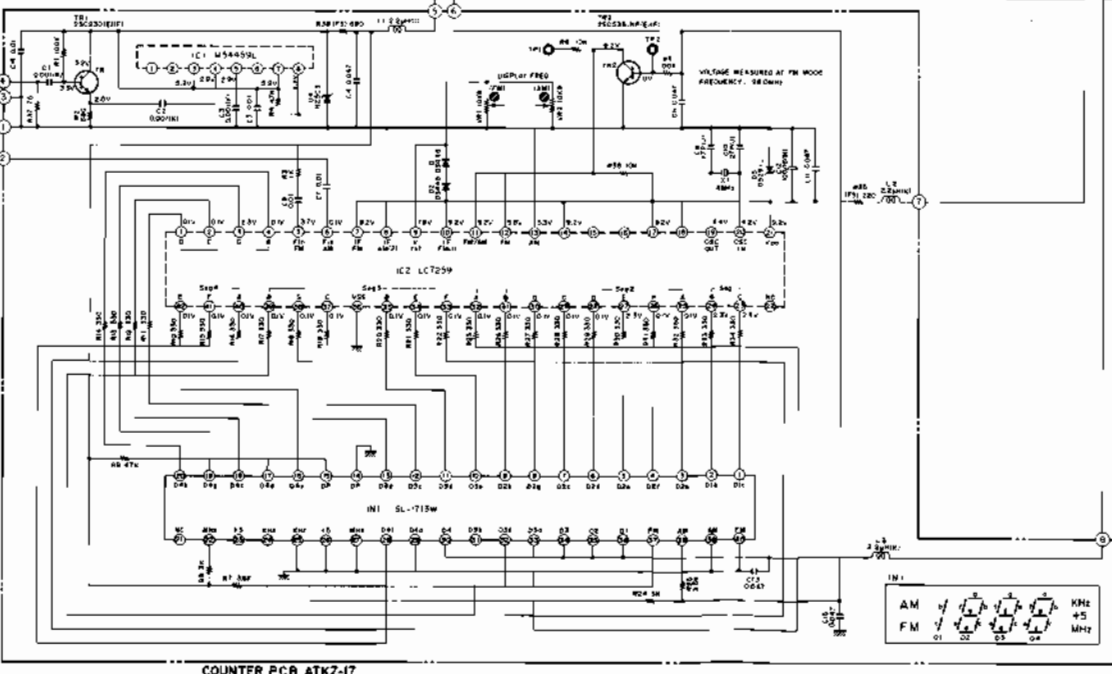
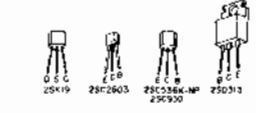
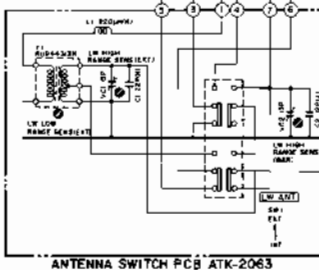

WARNING: INDICATES SAFETY CRITICAL COMPONENTS FOR CONTINUED SAFETY. REPLACE SAFETY CRITICAL COMPONENTS ONLY WITH MANUFACTURER'S RECOMMENDED PARTS.
 AVERTISSEMENT: IL INDIQUE LES COMPOSANTS CRITIQUES DE SÛRETÉ POUR MAINTENIR LE NIVEAU DE SÛRETÉ DE L'APPAREIL. NE REMPLACEZ LES COMPOSANTS CRITIQUES QUE PAR DES PIÈCES RECOMMANDÉES PAR LE FABRICANT.

NOTE: UNLESS OTHERWISE SPECIFIED:
 ALL RESISTORS 1/4WATT 5%
 ALL CAPACITORS 50V 50%
 ALL DIODES 1N4148
 POWER TRANSFORMER IS DIFFERENT ACCORDING TO AREA

AT-K33L
 SCHEMATIC DIAGRAM
 NO. 1621060A

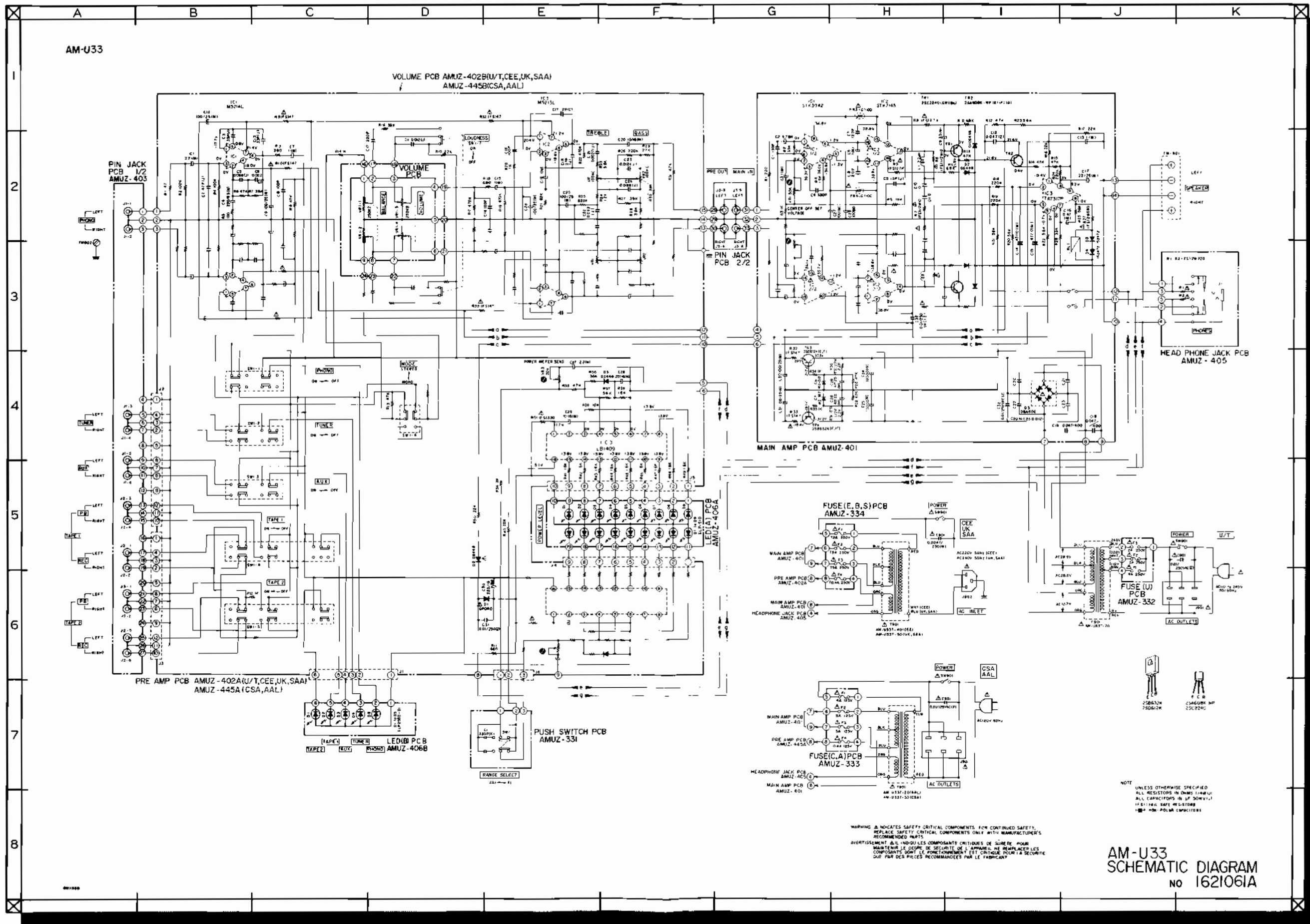

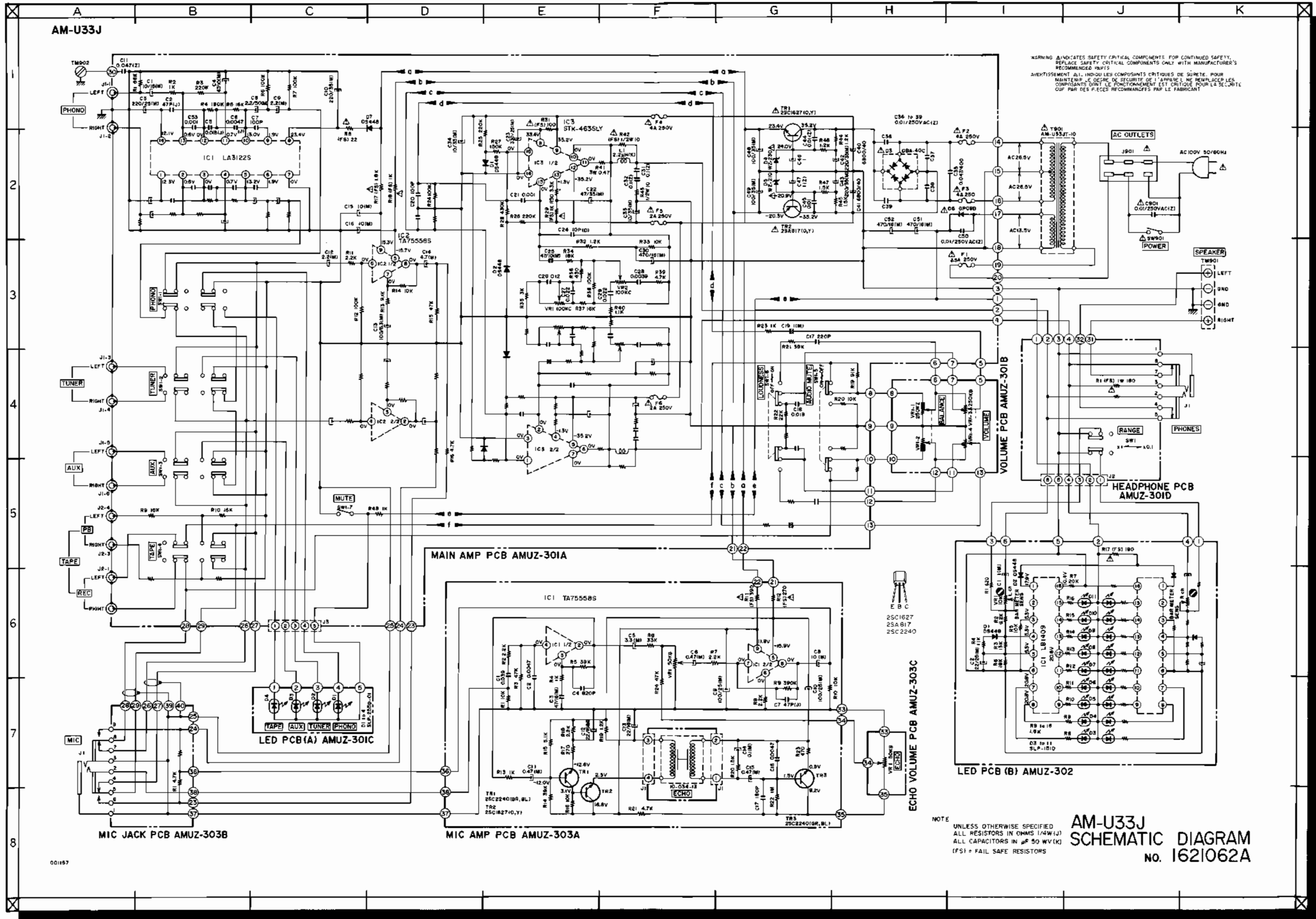

WARNING INDICATES SAFETY CRITICAL COMPONENTS. FOR CONTINUED SAFETY, REPLACE SAFETY CRITICAL COMPONENTS ONLY WITH MANUFACTURER'S RECOMMENDED PARTS.
 AVERTISSEMENT: IL Y A DES COMPOSANTS CRITIQUES DE SÛRETÉ. POUR MAINTENIR LE DEGRÉ DE SÛRETÉ DE L'APPAREIL, NE REMPLACEZ LES COMPOSANTS DONT LE FONCTIONNEMENT EST CRITIQUE POUR LA SÛRETÉ QUE PAR DES PÉCES RECOMMANDÉES PAR LE FABRICANT.

NOTE: UNLESS OTHERWISE SPECIFIED, ALL RESISTORS IN OHMS (1/4W/1%), ALL CAPACITORS IN μ F 50 WV(1K) (FS) = FAIL SAFE RESISTORS.

AM-U33J SCHEMATIC DIAGRAM No. 1621062A

001167