

MODEL AT-2600

ATAAT

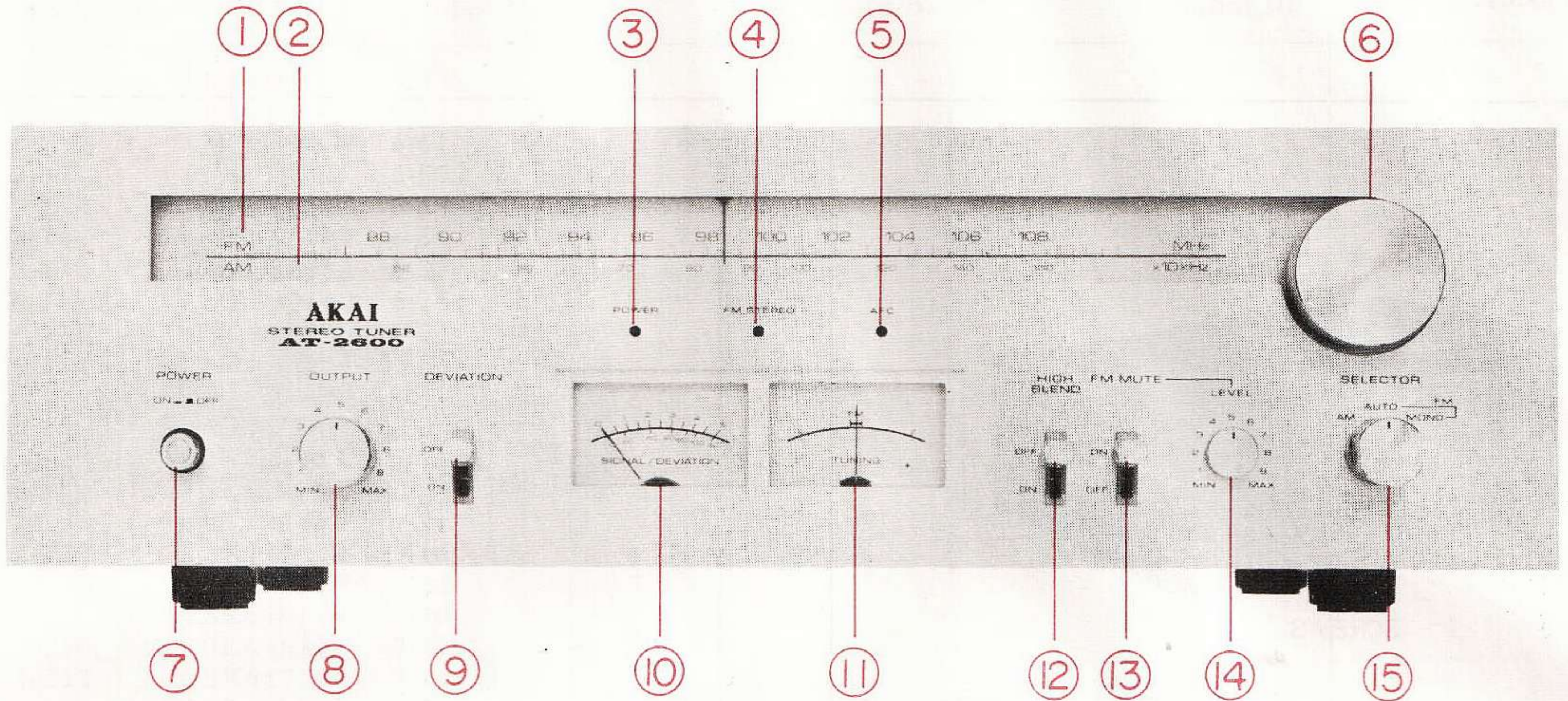
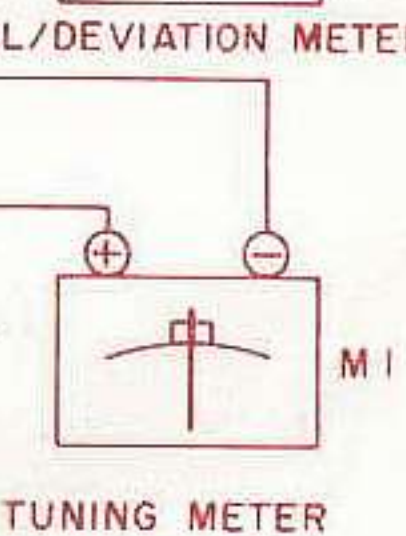
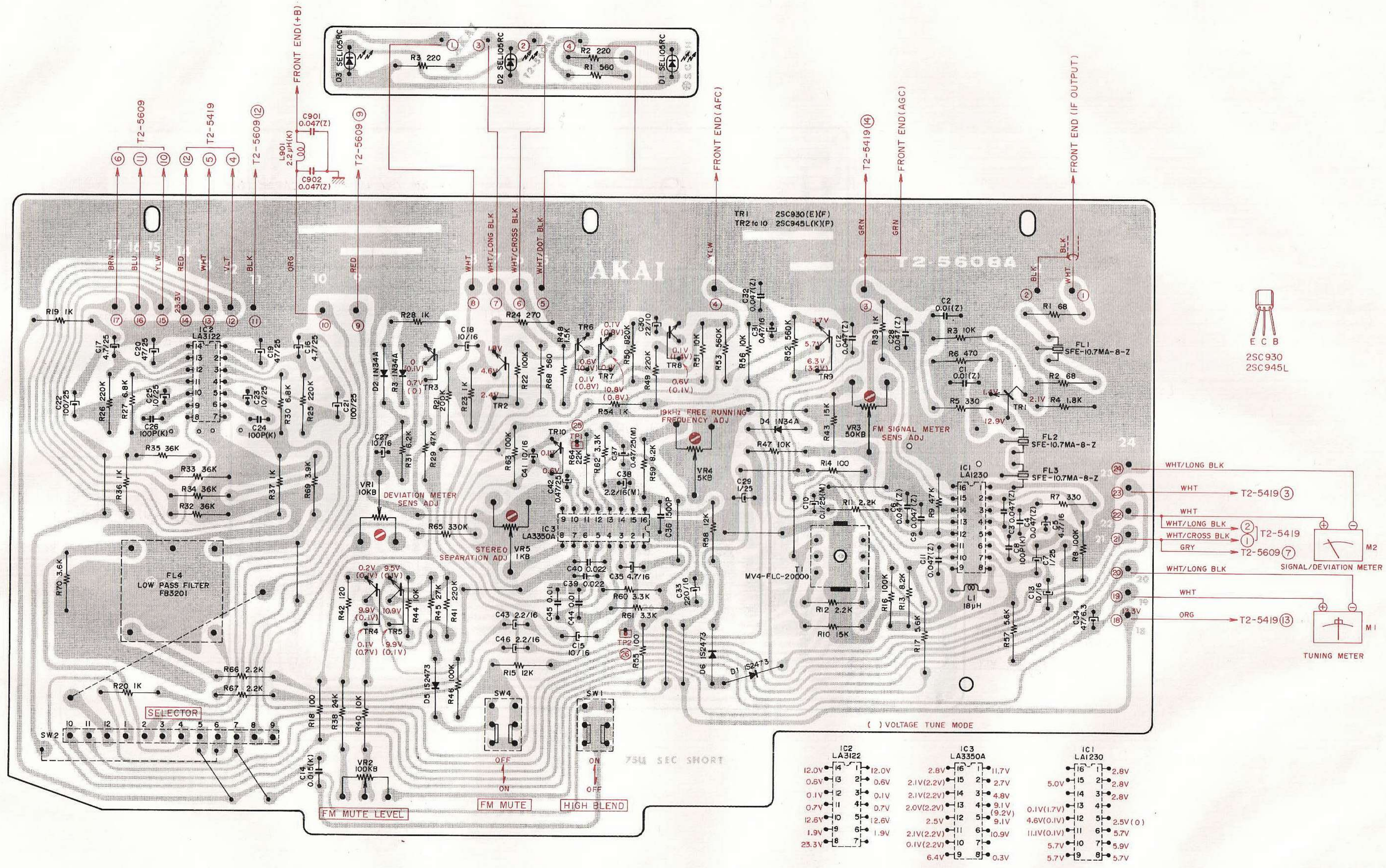

Fig. 1 Controls

- | | |
|-----------------------------|--|
| 1. FM DIAL SCALE | 9. DEVIATION SWITCH |
| 2. AM DIAL SCALE | 10. SIGNAL STRENGTH/DEVIATION METER |
| 3. POWER INDICATOR LAMP | 11. FM TUNING METER |
| 4. FM STEREO INDICATOR LAMP | 12. HIGH BLEND SWITCH |
| 5. AFC INDICATOR LAMP | 13. FM MUTE SWITCH |
| 6. TUNING KNOB | 14. FM MUTE LEVEL ADJUSTER |
| 7. POWER SWITCH | 15. INPUT SELECTOR (AM, FM AUTO and FM MONO) |
| 8. OUTPUT LEVEL CONTROL | |

2. COMPOSITION OF VARIOUS P.C BOARDS

1) FM IF P.C BOARD T2-5608A & LED P.C BOARD T2-5608B



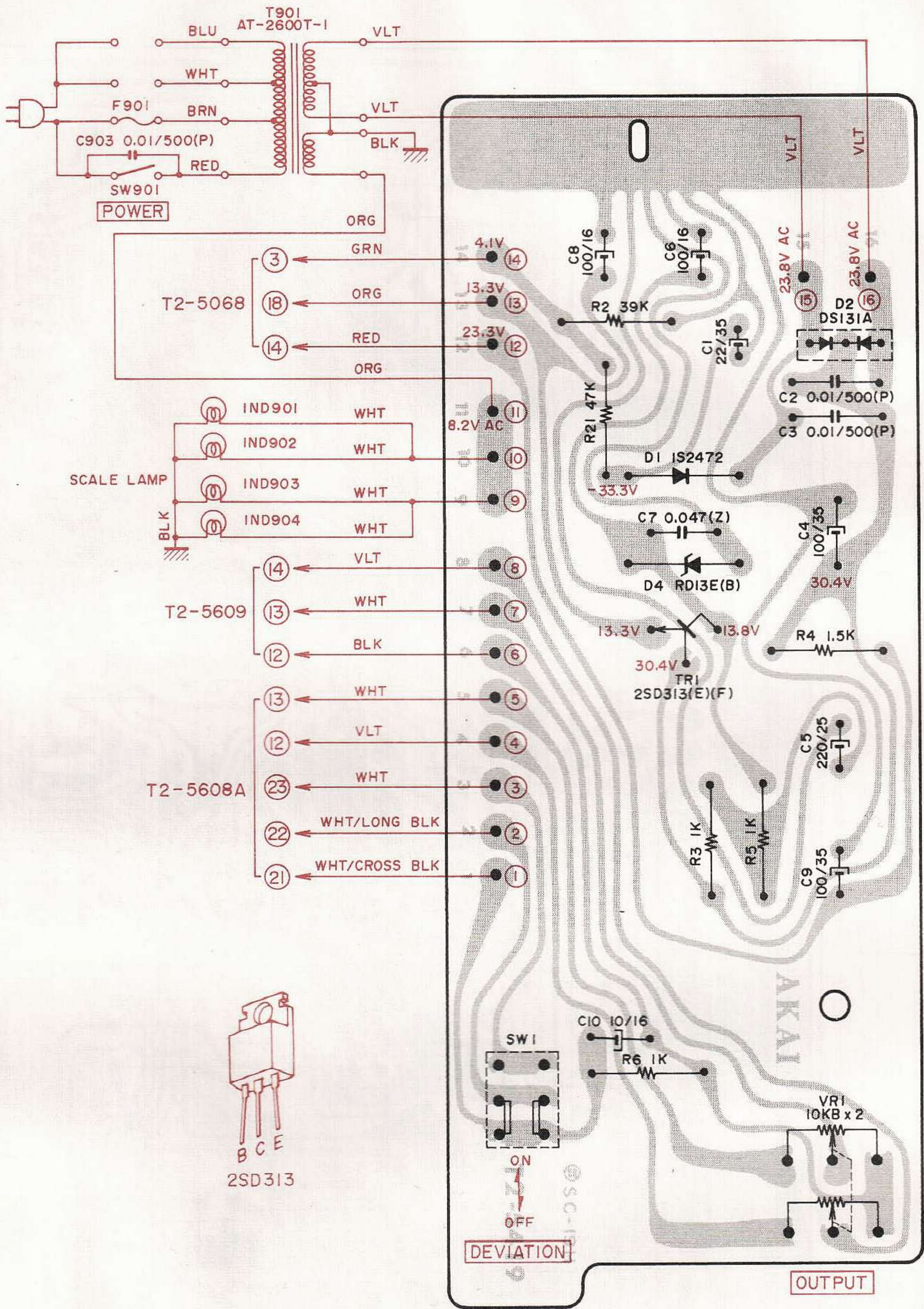

POWER

SCALE LAMP

T2-5608A

T2-5609

T2-5068

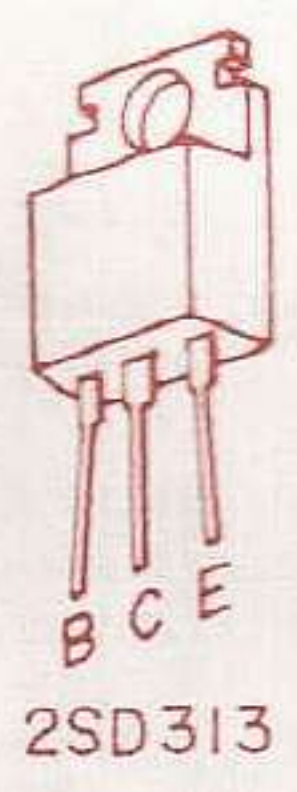

DEVIATION

OUTPUT

AKAI

T2
75 OHMS - 300 OHMS

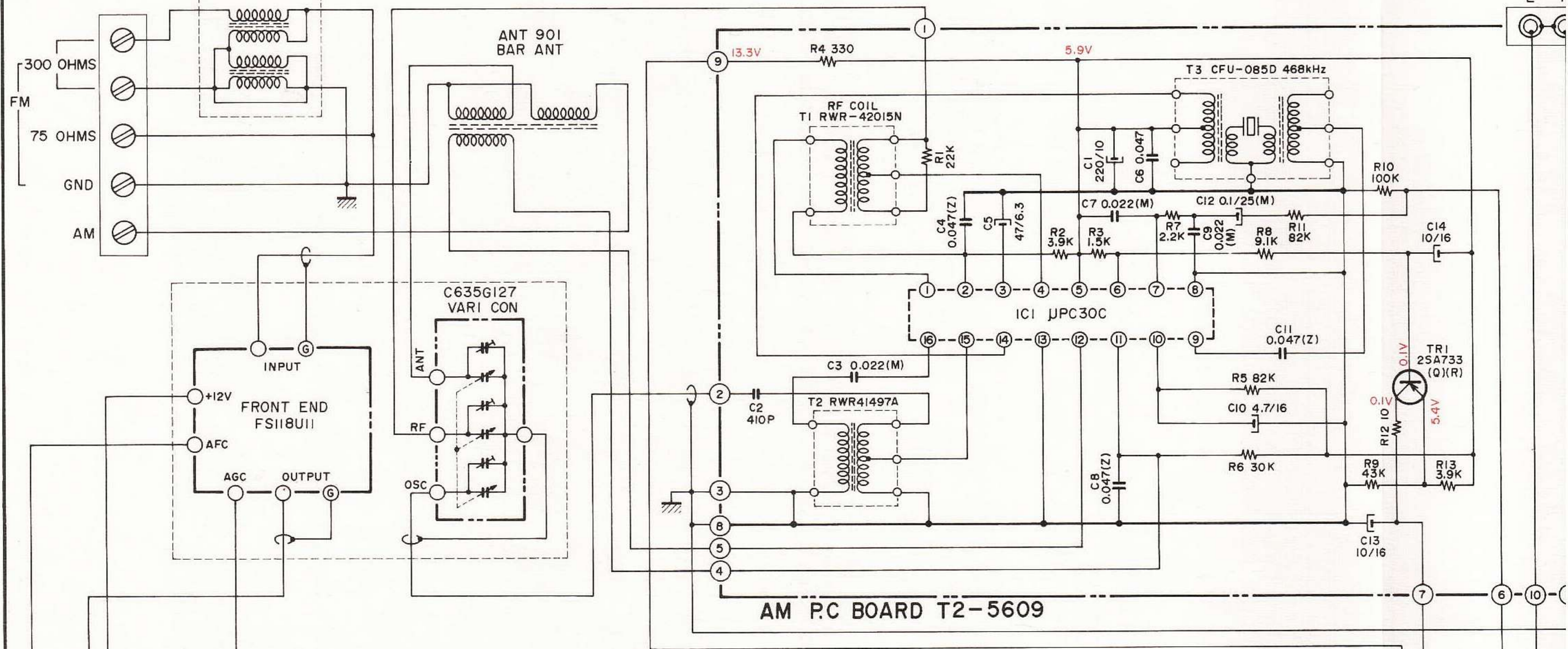

AM P.C. BOARD T2-5609

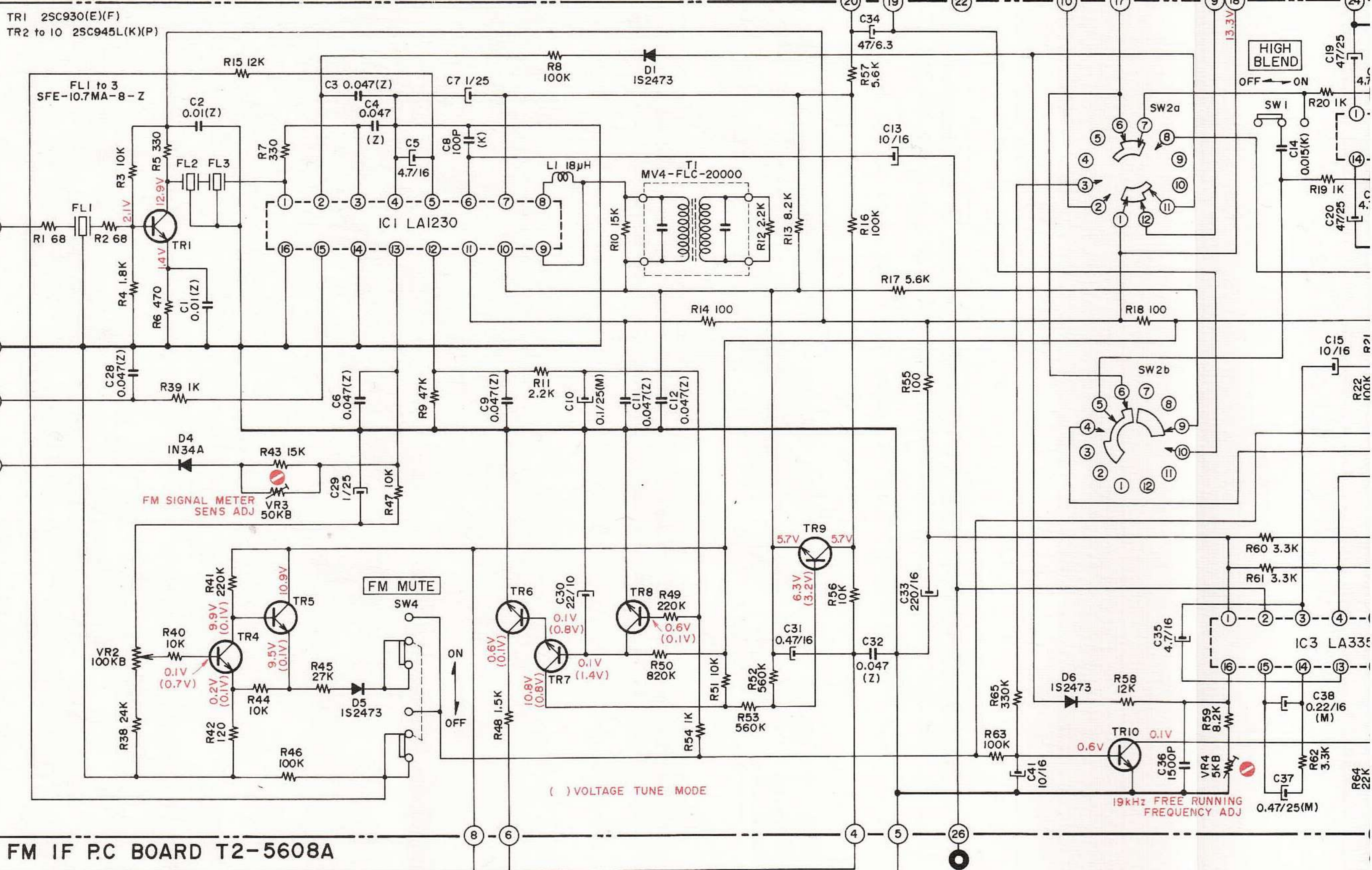
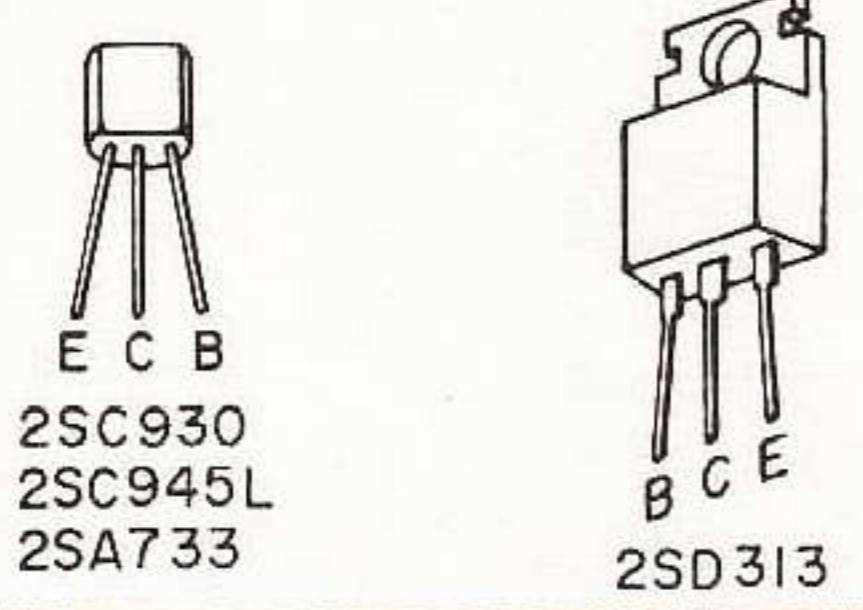

FM IF P.C. BOARD T2-5608A

SW2 SELECTOR
 AM NOW MODE
 FM AUTO
 FM MONO

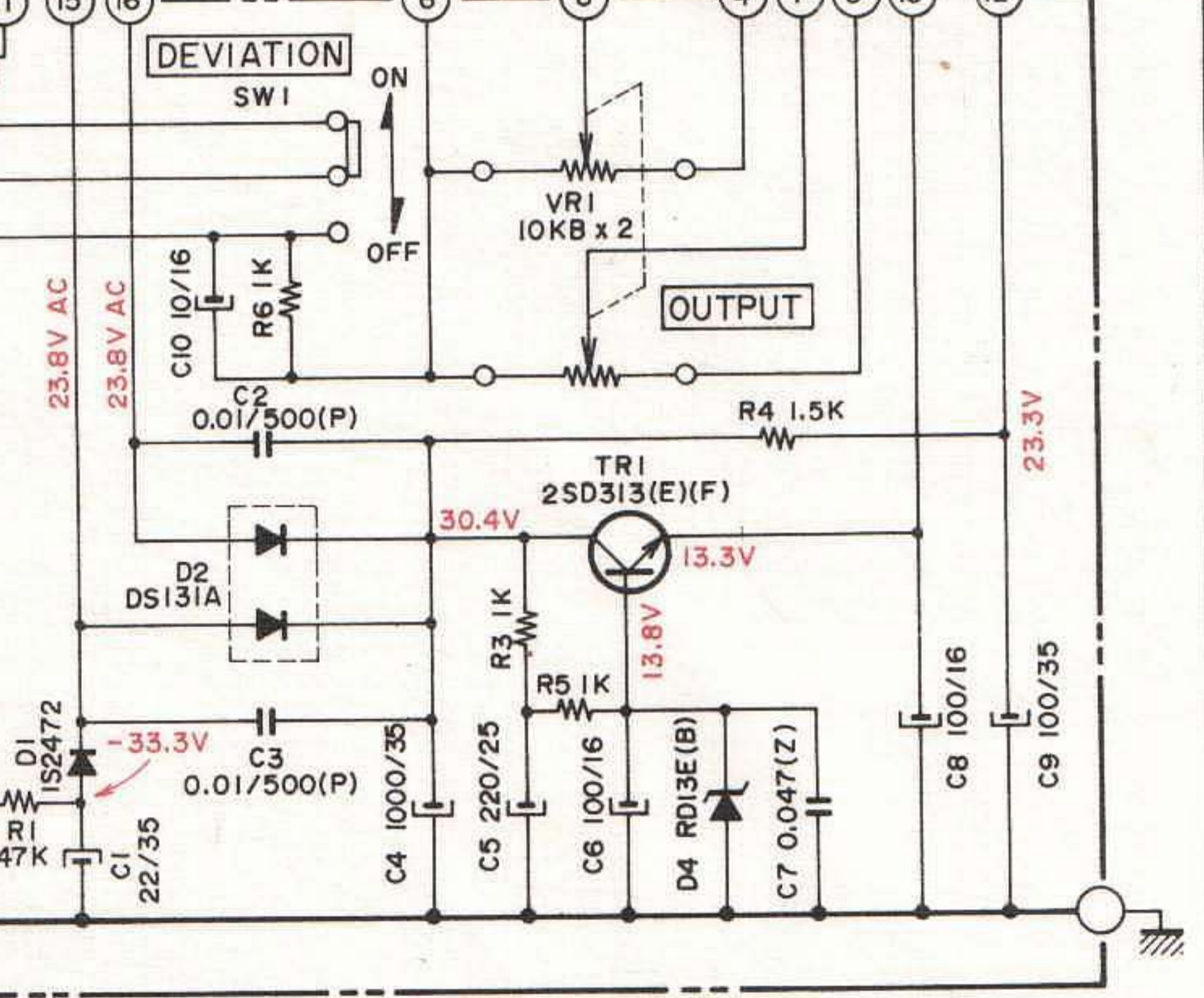
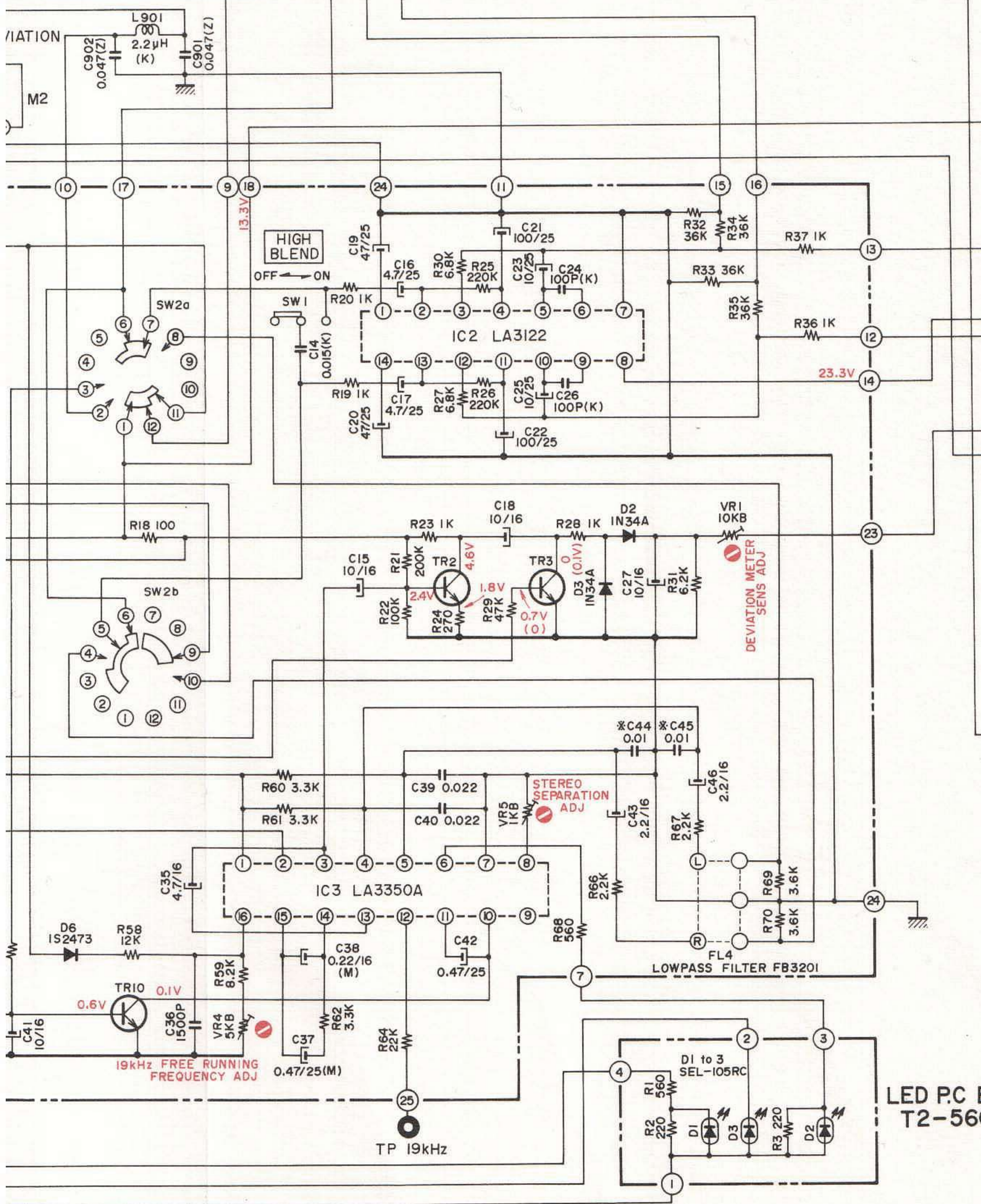
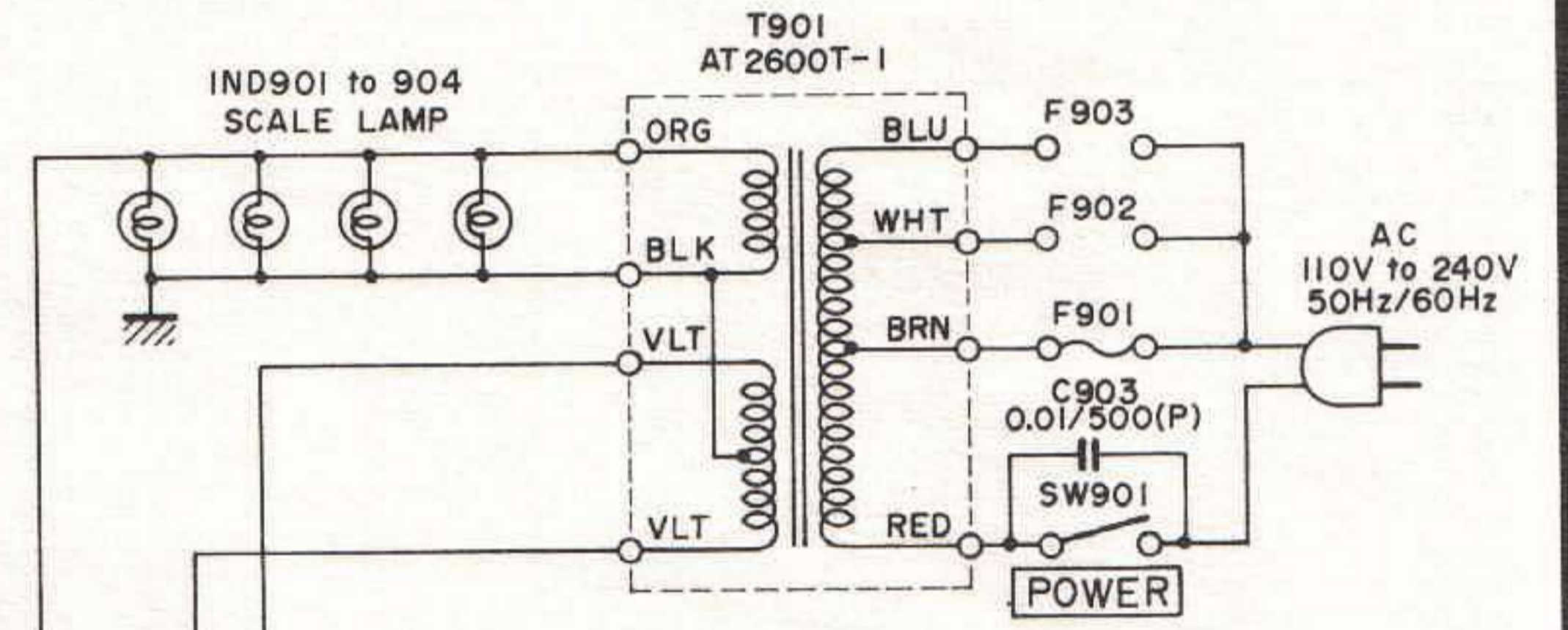
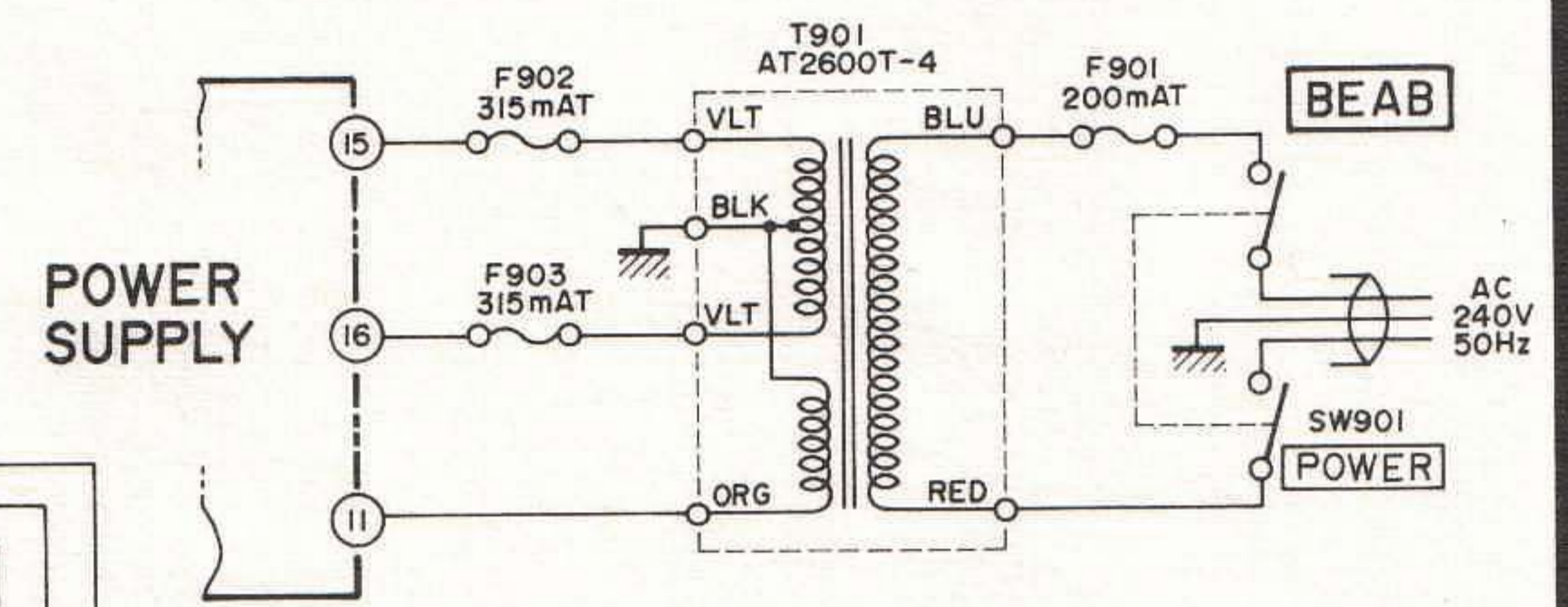
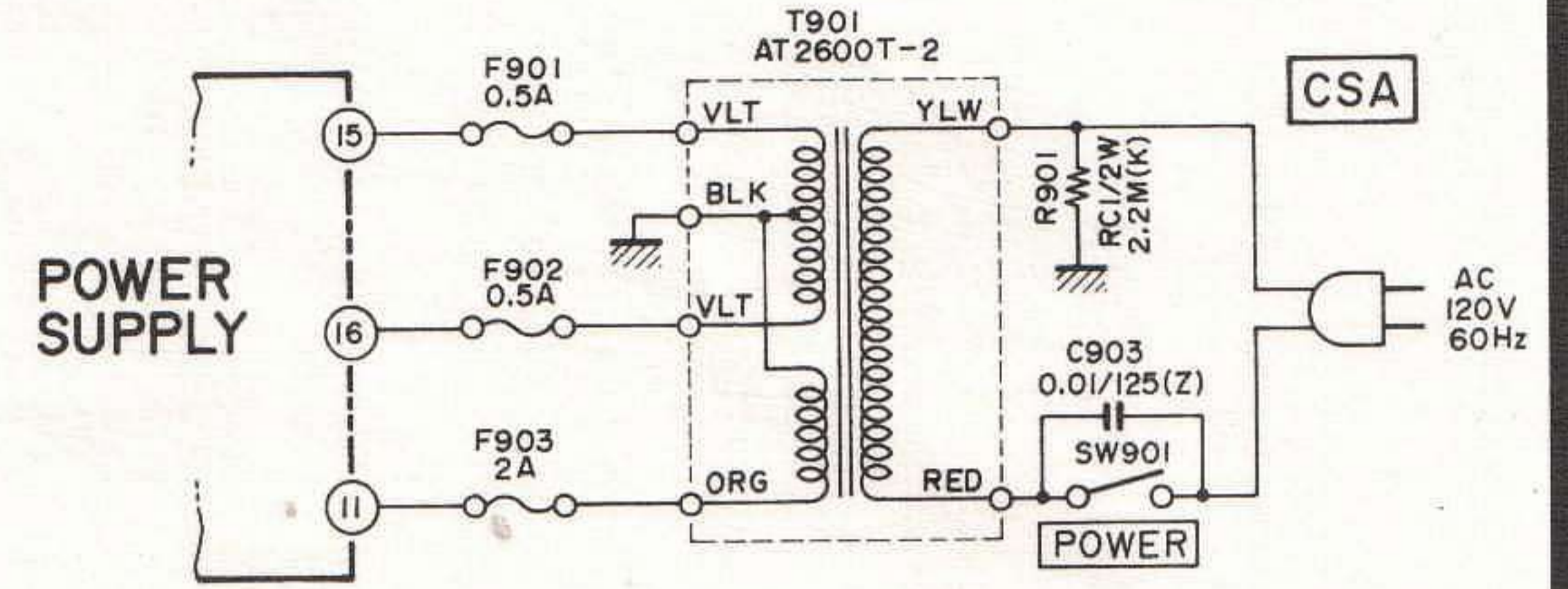
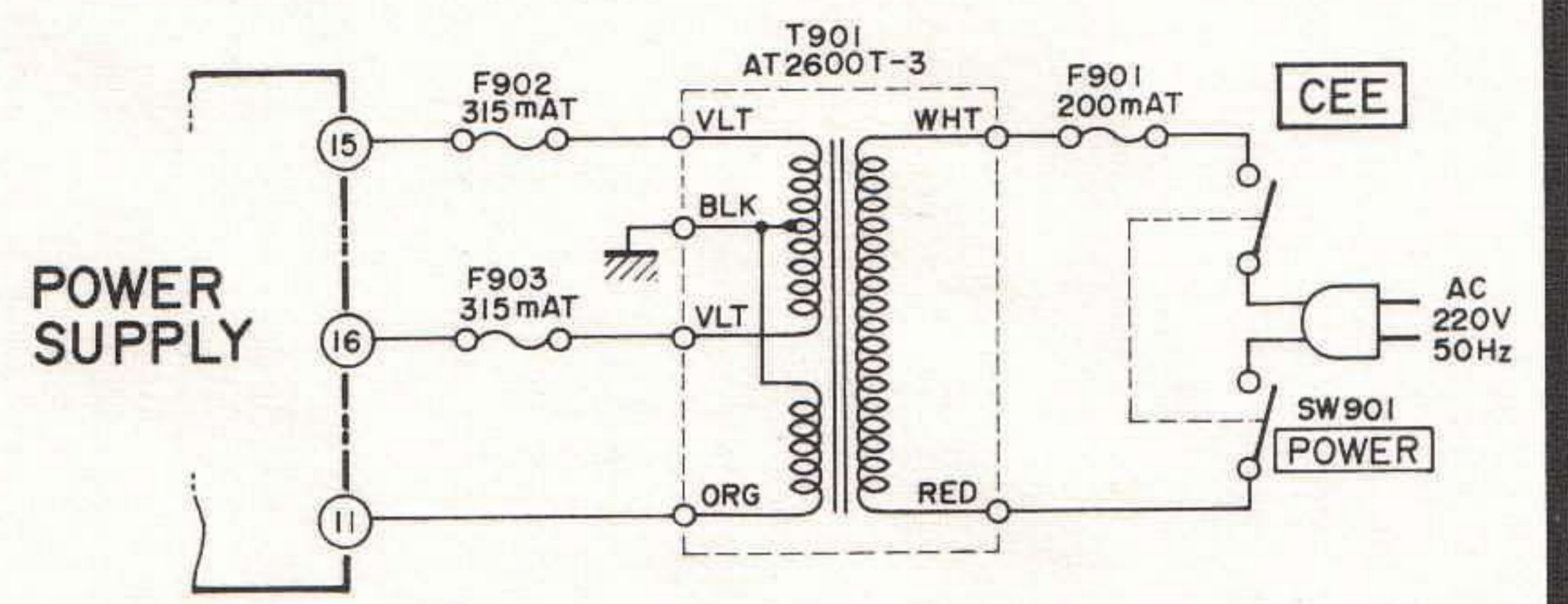
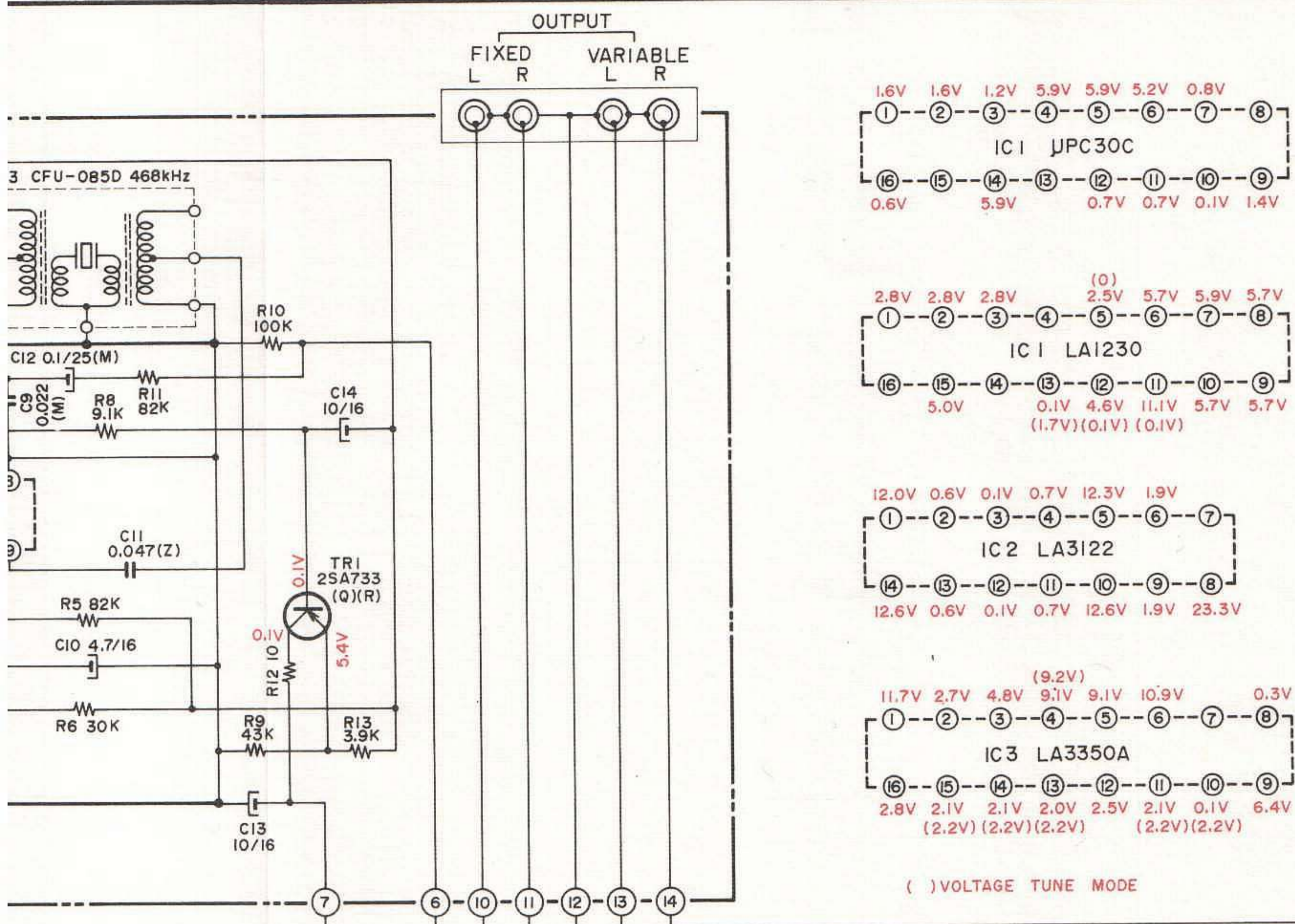

- NOTE
- UNLESS OTHERWISE SPECIFIED ALL RESISTORS IN OHMS 1/4W(J) ALL CAPACITORS IN μ F 50WV(J) P = μ μ F
 - POWER TRANSFORMER IS DIFFERENT ACCORDING TO AREA

AT-2600 SCHEMATIC DIAGRAM

No.2-1 1540644A

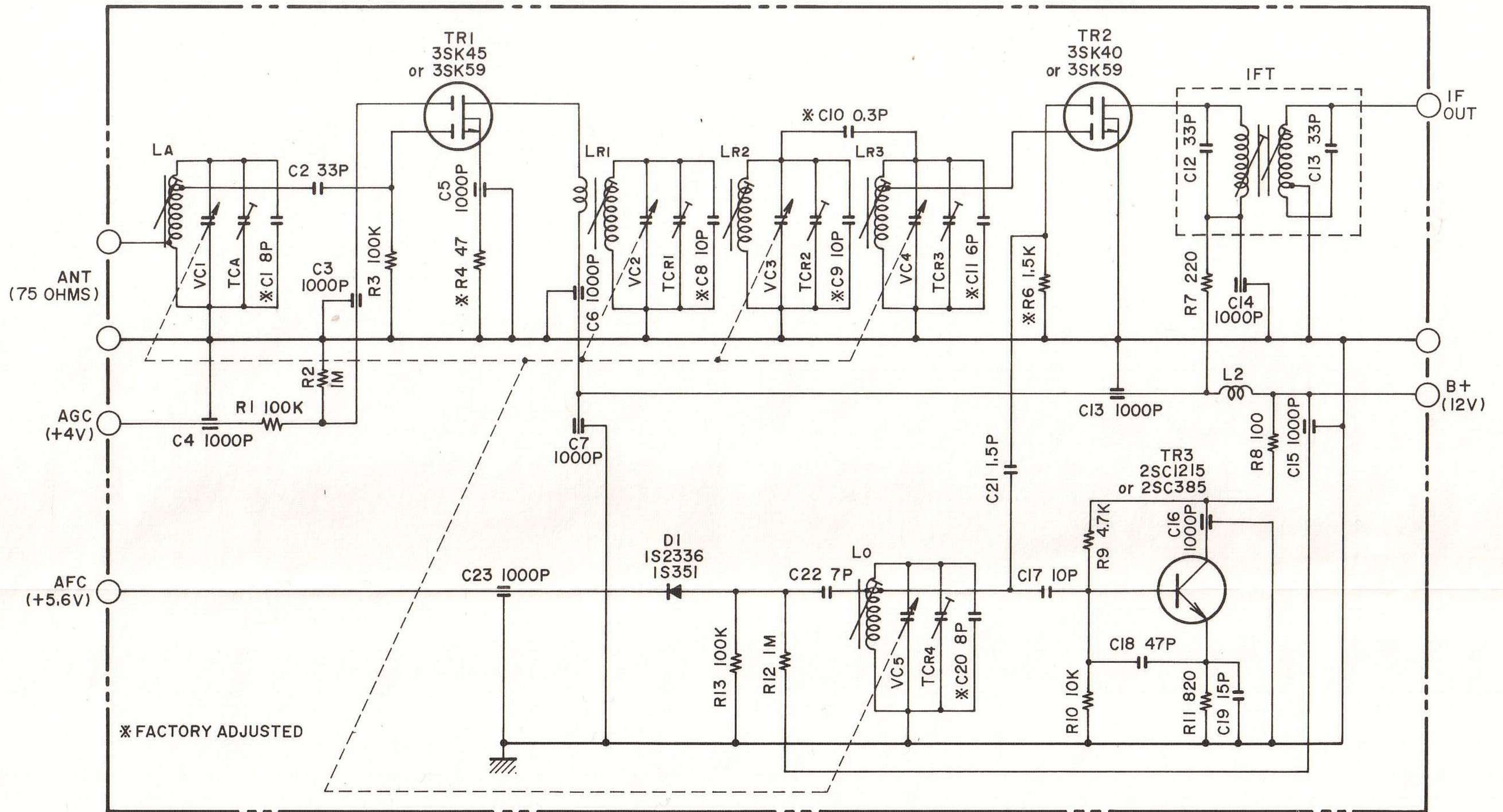

AT-2600 FRONT END
 FS118U11
 NO. 2-2 1540645A