

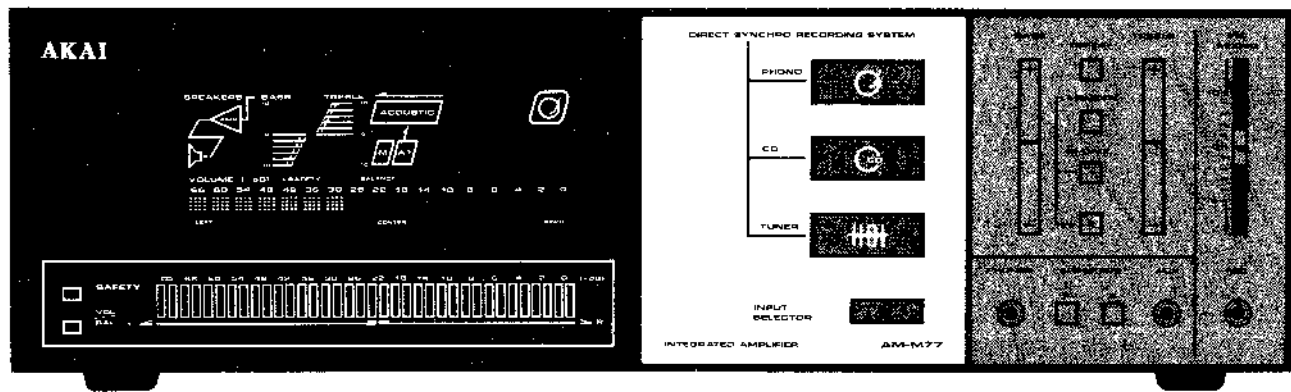

# SERVICE MANUAL



INTEGRATED AMPLIFIER

MODEL **AM-M77**

---

## ABBREVIATIONS FOR SERVICE MANUAL MODEL AM-M77

ABBREVIATIONS	EXPLANATION
AMP	AMPlifier
AC	Alternate Current
A/D	Analogue/Digital, (Analogue to Digital)
CD	Compact Disc (Player)
CK	Clock
D	Data
DC	Direct Current
EIAJ	Electronic Industries Association of Japan
FLD	Floresent Light Display
FTC	Federal Trade Commission
GND	GrouND
IHF	Institute of High Fidelity (Standard)
MIC	MICrophone
OP-AMP	OPerational-AMPlifier
PCB	Printed Circuit Board
REC	RECORD
RIAA	Recording Industry Association of America
RST	ReSeT
SEG	SEGment
ST	STrob
SW	SWitch

---

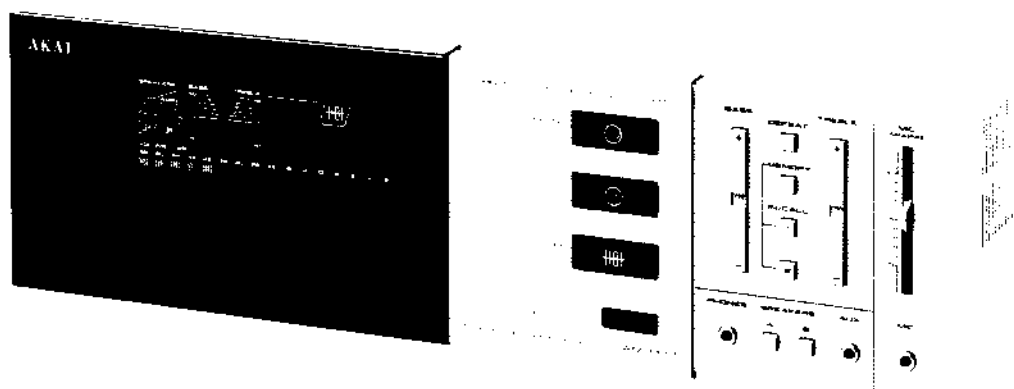

## INTEGRATED AMPLIFIER

### MODEL **AM-M77**

THIS MANUAL IS APPLICABLE TO BOTH SILVER AND BLACK PANEL MODEL

SECTION 1	SERVICE MANUAL .....	3
SECTION 2	PARTS LIST .....	11

# SAFETY INSTRUCTIONS

## SAFETY CHECK AFTER SERVICING

Confirm the specified insulation resistance between power cord plug prongs and externally exposed parts of the set is greater than 10 Mohms, but for equipment with external antenna terminals (tuner, receiver, etc.) and is intended for **C** or **A**, specified insulation resistance should be more than 2.2 Mohms (ground terminals, microphone jacks, headphone jacks, line-in-out jacks etc.)

## PRECAUTIONS DURING SERVICING

1. Parts identified by the  $\triangle$  symbol parts are critical for safety.  
Replace only with parts number specified.
2. In addition to safety, other parts and assemblies are specified for conformance with such regulations as those applying to spurious radiation. These must also be replaced only with specified replacements.  
Examples: RF converters, tuner units, antenna selector switches, RF cables, noise blocking capacitors, noise blocking filters, etc.
3. Use specified internal wiring. Note especially:
  - 1) Wires covered with PVC tubing
  - 2) Double insulated wires
  - 3) High voltage leads
4. Use specified insulating materials for hazardous live parts. Note especially:
  - 1) Insulation Tape
  - 2) PVC tubing
  - 3) Spacers (Insulating Barriers)
  - 4) Insulation sheets for transistors
  - 5) Plastic screws for fixing microswitch (especially in turntable)
5. When replacing AC primary side components (transformers, power cords, noise blocking capacitors, etc.), wrap ends of wires securely about the terminals before soldering.

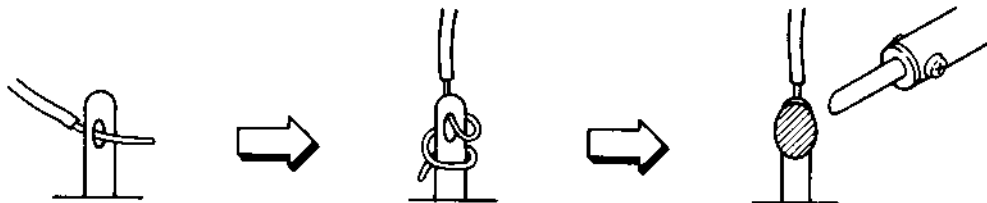

6. Observe that wires do not contact heat producing parts (heatsinks, oxide metal film resistors, fusible resistors, etc.).
7. Check that replaced wires do not contact sharp edged or pointed parts.
8. Also check areas surrounding repaired locations.
9. Use care that foreign objects (screws, solder droplets, etc.) do not remain inside the set.

## VOLTAGE CONVERSION

Models for Japan, USA, Canada, Europe, UK and Australia are not equipped with this facility.

Each machine is preset at the factory according to its destination, but some machines can be set to 110V, 120V, 220V or 240V as required.

If your machine's voltage can be converted:

- 1) Confirm so that the power cord is Disconnected.
- 2) turn the VOLTAGE SELECTOR located on the rear panel with a screwdriver until the correct voltage is indicated.

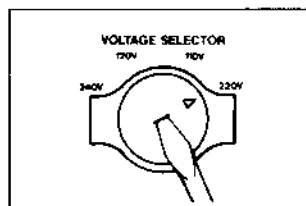

---

SECTION 1

**SERVICE MANUAL**

TABLE OF CONTENTS

I. SPECIFICATIONS .....	4
II. DISMANTRING OF UNIT .....	5
III. CONTROLS .....	6
IV. PRINCIPAL PARTS LOCATION .....	7
V. DESCRIPTION OF THE CIRCUIT OPERATION .....	8
1. CONTROL OVER INPUT SELECTOR ANALOG SWITCH (TC9164S) .....	8
2. CONTROL OVER ELECTRONIC POTENTIOMETERS (TS9154P AND TC9156P) .....	8
VI. ADJUSTMENT .....	9
VII. P.C BOARD TITLE AND IDENTIFICATIONS .....	9

For basic adjustments, measuring methods, and operating principles, refer to GENERAL TECHNICAL MANUAL.

# I. SPECIFICATIONS

<b>POWER AMPLIFIER SECTION</b>			
<b>RATED OUTPUT POWER</b> (2 channels driven) 20Hz to 20kHz 1kHz (EIAJ)	8 ohms 45/0.02% 65W/5%	6 ohms 45W/0.02%	4 ohms 80W/5%
<b>OUTPUT POWER BY FTC</b> (2 channels driven) 20Hz to 20kHz 1kHz	8 ohms 50W/0.02% 50W/0.02%	6 ohms 52W/0.03% 53W/0.02%	4 ohms 52W/0.03% 55W/0.02%
<b>FRENCH NORMAL</b> 63Hz to 12.5kHz 1kHz	8 ohms 52W/0.7% 55W/0.7%		
<b>MUSIC POWER (Both channel)</b>	240W		
<b>POWER BANDWIDTH (IHF-3dB, 8 ohms)</b>	5Hz to 70kHz (0.1%)		
<b>S/N (IHF-A)</b>			
PHONO	70dB		
CD	92dB		
TAPE	92dB		
MIC	63dB		
<b>RESIDUAL NOISE (8 ohms)</b>	0.5mV		
<b>CHANNEL SEPARATION (IHF, 1kHz)</b>	50dB		
<b>DAMPING FACTOR (1kHz, 8 ohms)</b>	35		
<b>REQUIRED SPEAKER IMPEDANCE</b>			
USA, Canada, Europe, UK and Australia	A or B : 6 to 16 ohms A + B : 12 to 16 ohms		
Others	A or B : 4 to 16 ohms A + B : 8 to 16 ohms		
<b>PRE AMPLIFIER SECTION</b>			
<b>INPUT SENSITIVITY/IMPEDANCE</b>			
PHONO	2.5mV/47kohms		
CD	150mV/47kohms		
MIC	0.7mV/10kohms		
<b>OUTPUT LEVEL/IMPEDANCE</b>			
TAPE REC	150mV/1.5kohms		
<b>FREQUENCY RESPONSE</b>			
PHONO (RIAA deviation)	20Hz to 20kHz, $\pm 0.5$ dB		
AUX/TUNER/TAPE	5Hz to 80kHz 0dB, $-3$ dB		
<b>TONE CONTROL</b>			
BASS	+8dB/100Hz		
TREBLE	+8dB/10kHz		
<b>POWER REQUIREMENTS</b>	100V, 50/60Hz for Japan 120V, 60Hz for USA & Canada 220V, 50Hz for Europe except UK 240V, 50Hz for UK & Australia 110V/120V/220V/240V, 50/60Hz switchable for other countries		
<b>POWER CONSUMPTION</b>	190W (A, C Models) 120W (J Model) 240W (U Model)		
<b>DIMENSIONS</b>	350 (w) x 104 (H) x 255 (D)mm (13.8 x 4.1 x 10 inches)		
<b>WEIGHT</b>	6.3kg (13.9 lbs)		

\* For improvement purposes, specifications and design are subject to change without notice.

## II. DISMANTRING OF UNIT

In case of trouble, etc. necessitating dismantling, please dismantle in the order shown in the photographs. Reassemble in reverse order.

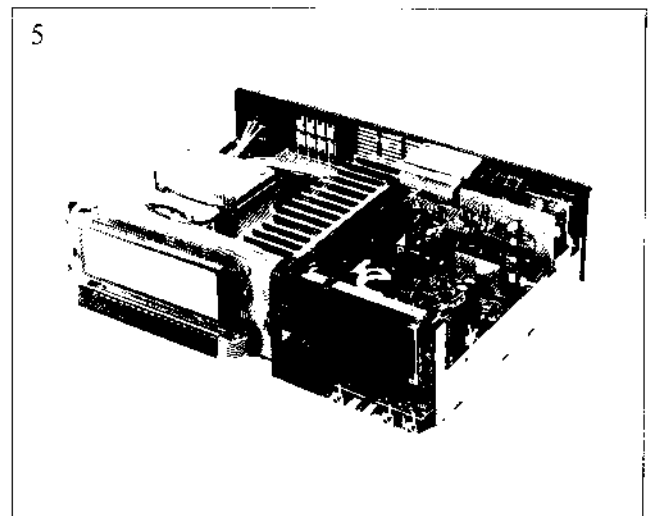
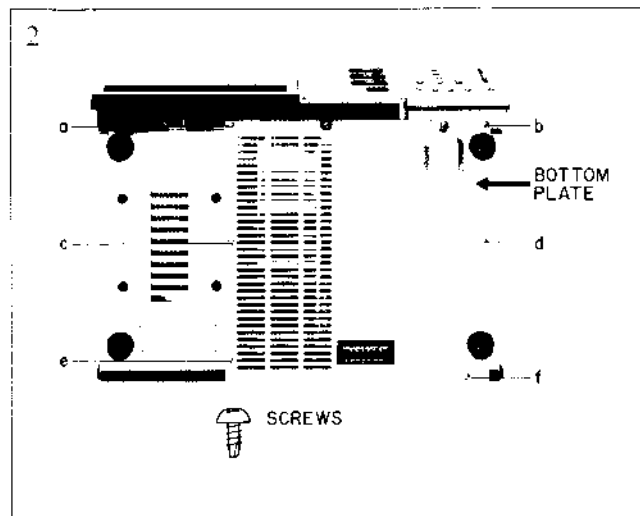
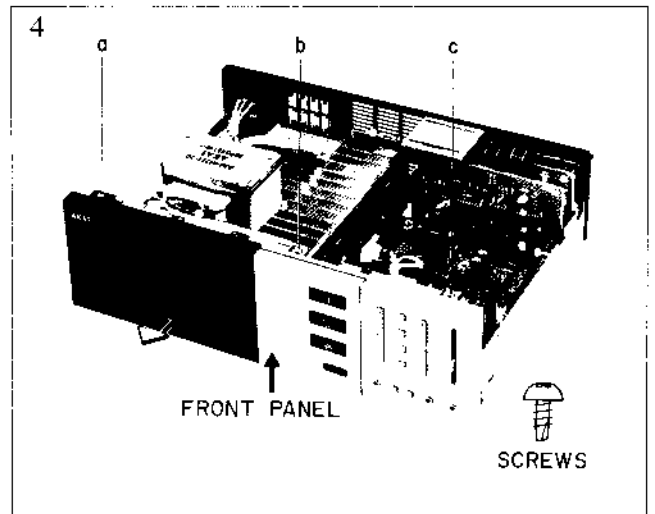
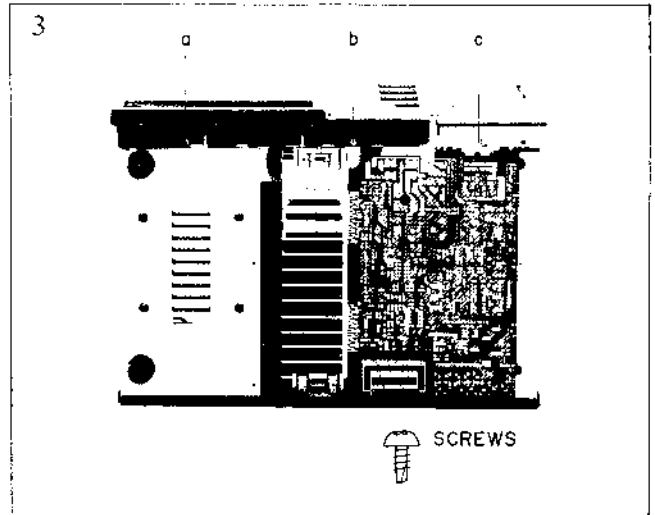
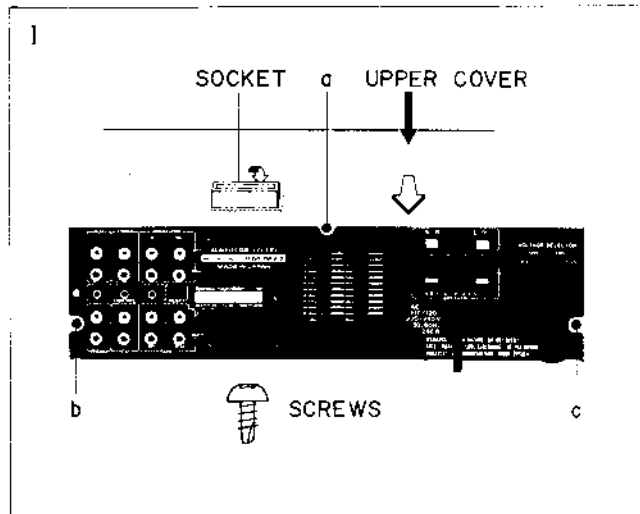

### III. CONTROLS

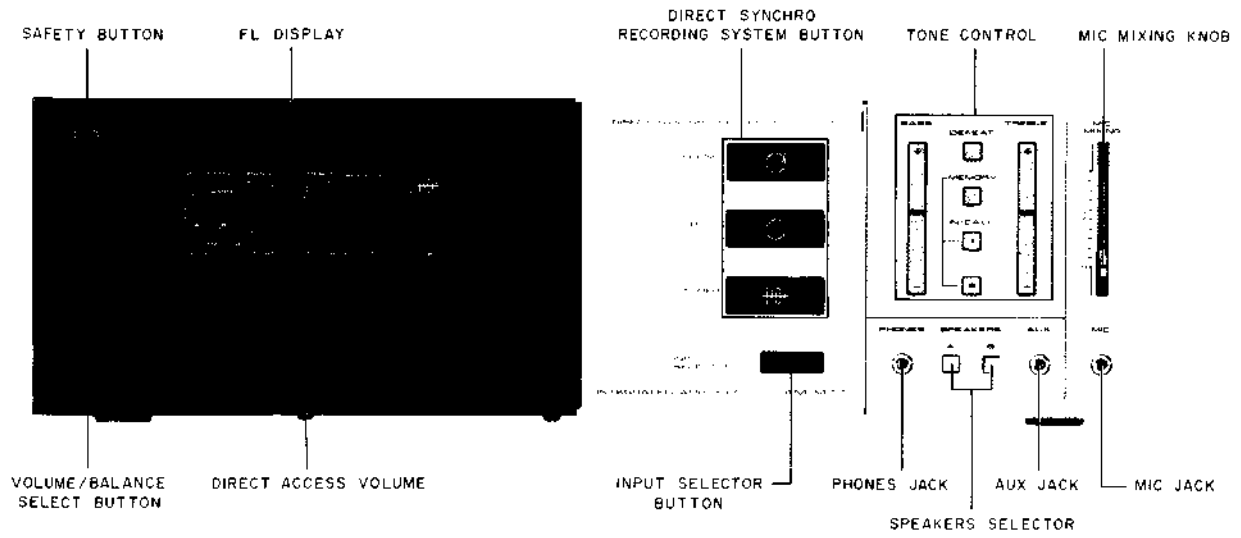

Fig. 3-1 Front View

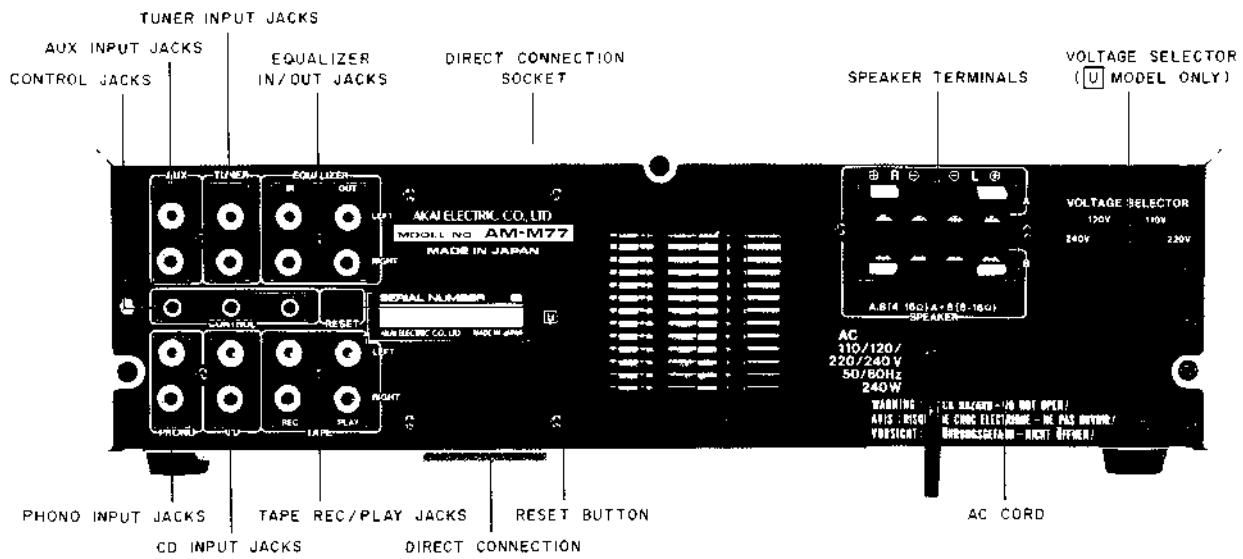

Fig. 3-2 Rear View



# IV. PRINCIPAL PARTS LOCATION

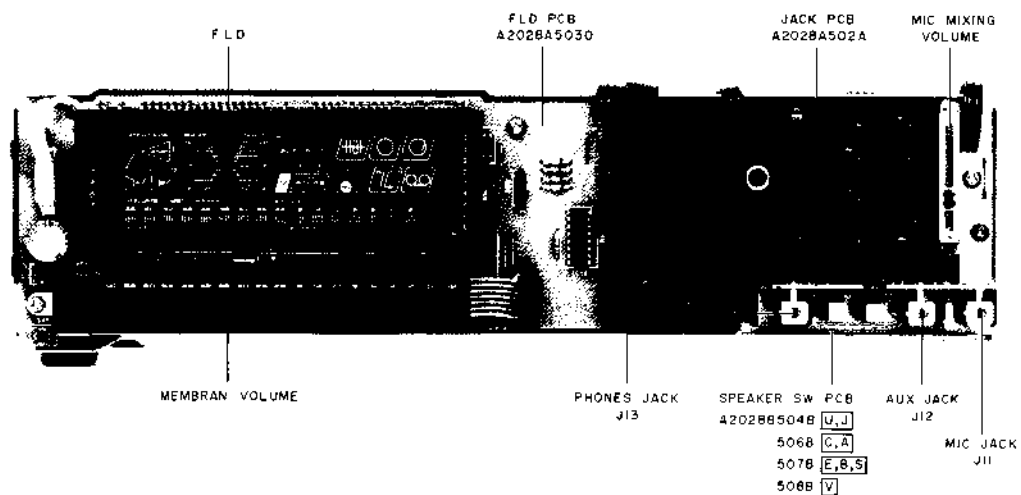

Fig. 4-1 Front View

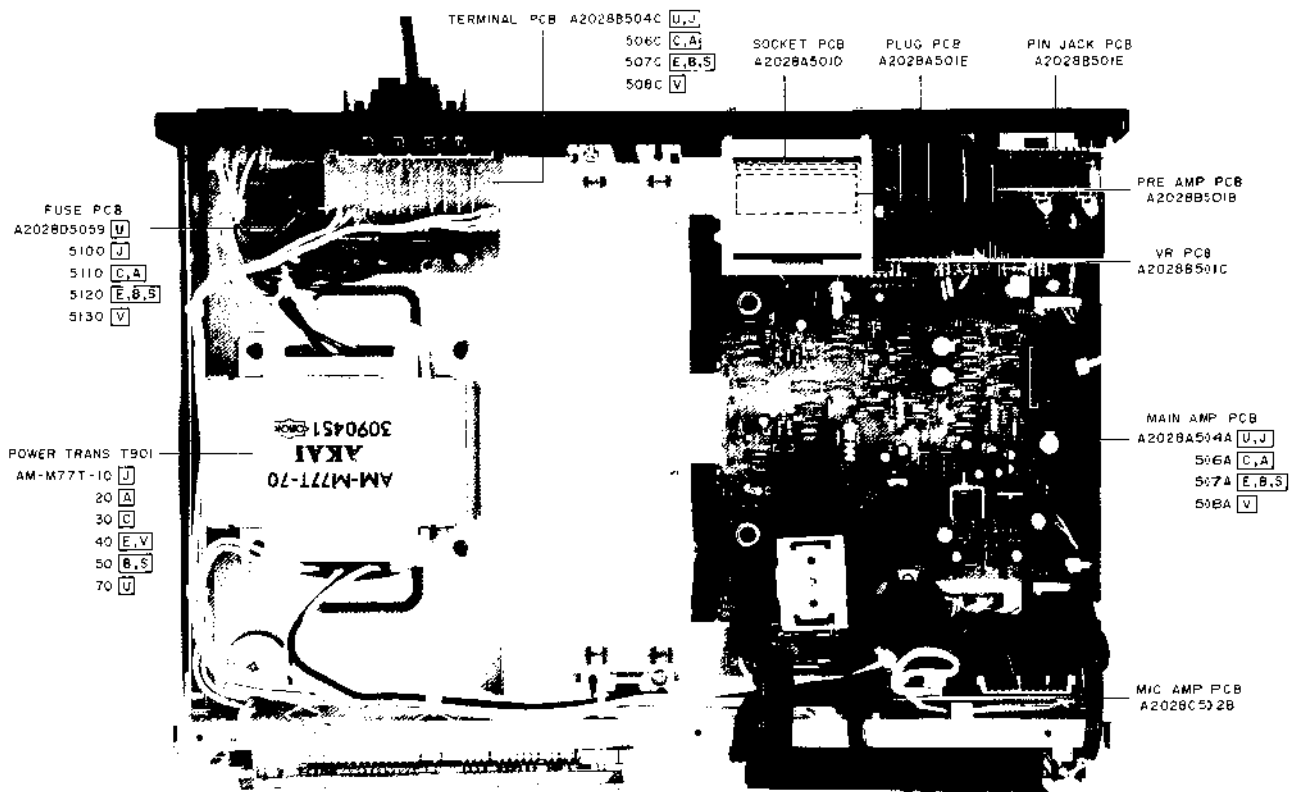

Fig. 4-2 Upper View

# V. DESCRIPTION OF THE CIRCUIT OPERATION

## 5-1. CONTROL OVER INPUT SELECTOR ANALOG SWITCH (TC9164S)

### 5-1-1. SERIAL DATA STRUCTURE

The serial data employed is a 14-bit data composed of data, CK, and ST arranged in a 3-bit parallel format, and is structured under the system that represents (1) and (0) with data at the upgoing edge of CK and loads it with the rise of ST. Its algorithm is the same as that of electronic potentiometers described later, and because of the arrangement that as long as no ST emerges, none of the transmitted data will be loaded, data and CK used for the analog switch will be in common with those for the potentiometer.

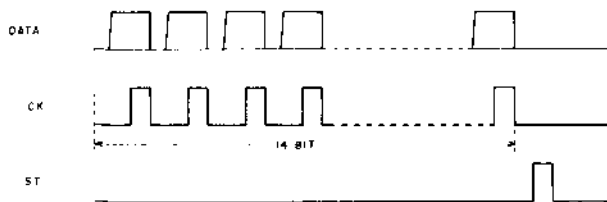

Fig. 5-1

### 5-1-2. DATA TYPES

Which bits of data will be made (1) is set in MFSRD0 through MFSRD3 of the RAM, and the relevant assignment schedule is as shown in the table below.

Input Selector	DATA								
	MFSRD3			MFSRD2			MFSRD1		MFSRD0
	AUX	TUNER	PHONO	Not used	TAPE	CD	REC	Not used	L R C <sub>1</sub> C <sub>2</sub> C <sub>3</sub> C <sub>4</sub>
AUX	1	0	0	0	0	0	1	0	1 1 0 1 0 0
TUNER	0	1	0	0	0	0	1	0	1 1 0 1 0 0
PHONO	0	0	1	0	0	0	1	0	1 1 0 1 0 0
TAPE	0	0	0	0	1	0	0	0	1 1 0 1 0 0
CD	0	0	0	0	0	1	1	0	1 1 0 1 0 0

(A) The bit 0 in MFSRD3 and MFSRD2 will always be sent as (0) because its corresponding switches in the analog switch IC (TC9164S) are as yet unused. The bits 2 and 3 in MFSRD1 will be left blank merely for software reasons, and will not even be transmitted.

## 5-2. CONTROL OVER ELECTRONIC POTENTIOMETERS (TS9154P AND TC9156P)

### 5-2-1. SERIAL DATA STRUCTURE

The serial data employed is an 18-bit data composed of data, CK, and ST arranged in a 3-bit parallel format, and its algorithm is identical to that of the analog switch described earlier.

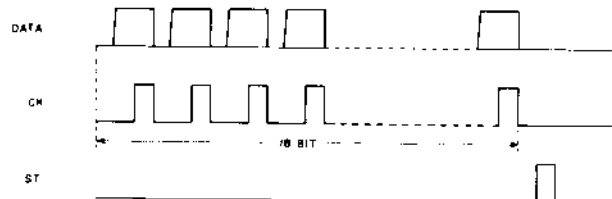

### 5-2-2. DATA TYPES

Data for the master volume control potentiometer (TC9154P) and the bass/treble control potentiometer (TC9156P) have both been assigned in MVSRD0 through MVSRD4 of the RAM.

a) Master Volume Control (TC9154P)

MVSRD4	MVSRD3	MVSRD2	MVSRD1	MVSRD0
0 10 20 30	40 50 60	0 2 4 6 8	Not used	L R C <sub>1</sub> C <sub>2</sub> C <sub>3</sub>
C <sub>1</sub> =0	C <sub>2</sub> =0	C <sub>3</sub> =0	Not used=0	

(B) The bits 2 and 3 in MVSRD1 will not be transmitted. All data transfers will always be made twice, separately for L and R.

MVSRD4	MVSRD3	MVSRD2	MVSRD1	MVSRD0
+5 +4 +3 +2	+1 Not used	Not used	1 2 3 4	5 L R C <sub>1</sub> C <sub>2</sub> C <sub>3</sub>

BASS TREBLE  
 C<sub>1</sub>=1 C<sub>1</sub>=0  
 C<sub>2</sub>=0 C<sub>2</sub>=1  
 C<sub>3</sub>=0 C<sub>3</sub>=0  
 Not used=0

## VI. ADJUSTMENT

No Adjustment is Necessary for this model.

## VII. P.C BOARD TITLE AND IDENTIFICATIONS

P.C BOARD TITLE		P.C BOARD NUMBER	REMARKS
MAIN AMP	P.C BOARD	A2028B504A	U, J
		506A	C, A
		507A	E, B, S
		508A	V
SPEAKER SW	P.C BOARD	A2028B504B	U, J
		506B	C, A
		507B	E, B, S
		508B	V
TERMINAL	P.C BOARD	A2028B504C	U, J
		506C	C, A
		507C	E, B, S
		508C	V
PIN JACK	P.C BOARD	A2028B501A	
SW	P.C BOARD	A2028B501B	
VR	P.C BOARD	A2028B501C	
PLUG	P.C BOARD	A2028B501D	
SOCKET	P.C BOARD	A2028B501E	
FLD	P.C BOARD	A2028B5030	
FUSE	P.C BOARD	A2028D5100	J
		D5110	C, A
		D5120	E, B, S
		D5130	V
		D5159	U
JACK	P.C BOARD	A2028C502A	
MIC AMP	P.C BOARD	A2028C502B	



---

SECTION 2

**PARTS LIST**

TABLE OF CONTENTS

RECOMMENDED SPARE PARTS .....	13
1. MAIN P.C BOARD BLOCK .....	13
2. PRE AMP P.C BOARD BLOCK .....	14
3. FLD P.C BOARD BLOCK .....	14
4. MIC AMP P.C BOARD BLOCK .....	14
5. FUSE P.C BOARD BLOCK .....	14
6. ASSEMBLY BLOCK .....	15
7. FINAL ASSEMBLY BLOCK .....	16
INDEX .....	16

Resistor and Capacitor which is not listed in this parts list, please refer to  
COMMON LIST FOR SERVICE PARTS.

## ATTENTION

1. When placing an order for parts, be sure to list the parts no., model no., and description. There are instances in which if any of this information is omitted, parts cannot be shipped or the wrong parts will be delivered.
2. Please be careful not to make a mistake in the parts no. If the parts no. is in error, a part different from the one ordered may be delivered.
3. Because parts number and parts unit supply in the Preliminary Parts List may be partially changed, please use this parts list for all future reference.

## HOW TO USE THIS PARTS LIST

1. This Parts List shows the parts that are considered necessary for repairs. Other parts, such as resistors and capacitors, are shown in the "Common List for Service Parts". Select and order such parts from the "Common List for Service Parts".
2. The Recommended Spare Parts shows those parts in the Parts List which are considered particularly important for service.
3. Parts not shown in the Parts List and "Common List for Service Parts" will not be supplied in principle.
4. How to read list
  - a) Mechanism Block
  - b) P.C Board Block

### 2. HEAD BASE BLOCK

REF. NO.	PARTS NO.	DESCRIPTION
2-1x	BH-T2023A320A	HEAD BASE BLOCK GX-F66R
2-2	HP-H2206A010A	HEAD R/P PR4-8FU C
2-3	ZS-477876	PAN20x03STL CMT
2-4	ZS-536488	BID20x08STL CMT
2-5	ZG-402895	CS ANGLE ADJUST SPRING

SP (Service Parts) Classification  
 A small "x" indicates the inability to show that particular part in the Photo or Illustration.  
 This number corresponds with the individual parts index number in that figure  
 This number corresponds with the Figure Number

### 6. SYS. CON. P.C BOARD BLOCK

REF. NO.	PARTS NO.	DESCRIPTION
6-1	BA-T2034A070A	PC SYS CON BLK GX-F44R
6-IC1	EI-324536	IC HD14049BP
6-IC2	EI-336801	IC MB8841-564M
6-IC3	EI-331661	IC SN7405N
6-IC4	EI-336725	IC M54527P
6-TR1to4	ET-200985	TR 2SC2603 F,G
6-TR5to28	ET-554657	TR 2SA733A P,Q
6-D1	ED-318292	D SILICON H 1S2473T-77 T26
6-D2to4	ED-308952	D GERMA V 1K34A-LR F07
6-D5to10	ED-318292	D SILICON H 1S2473T-77 T26
6-X1	EI-318384	OSC X'TAL NC-18C 3.579545MHZ

SP (Service Parts) Classification  
 This reference numbers corresponds with symbol numbers of Schematic Diagrams.

5. Both the kind of part and installation position can be determined by the Parts Number. To determine where a parts number is listed, utilize Parts Index at end of Parts List. It is necessary first of all to find the Parts Number. This can be accomplished by using the Reference Number listed at right of parts number in the Parts Index.

## WARNING

**⚠ INDICATES SAFETY CRITICAL COMPONENTS FOR CONTINUED SAFETY, REPLACE SAFETY CRITICAL COMPONENTS ONLY WITH MANUFACTURE'S RECOMMENDED PARTS**

## AVERTISSEMENT

**⚠ IL INDIQUE LES COMPOSANTS CRITIQUES DE SÉCURITÉ. POUR MAINTENIR LE DEGRÉ DE SÉCURITÉ DE L'APPAREIL, NE REMPLACER QUE DES PIÈCES RECOMMANDÉES PAR LE FABRICANT**

## RECOMMENDED SPARE PARTS

Because, if the parts listed below are on hand, almost any repair can be accomplished, we suggest that you stock these Recommended Spare Parts Items.

REF. NO.	PARTS NO.	DESCRIPTION
1	BT-351024	△ TRANS POWER AM-M77-30 (C)
2	BT-351023	△ TRANS POWER AM-M77T-10 (J)
3	BT-351025	△ TRANS POWER AM-M77T-20 (A)
4	BT-351026	△ TRANS POWER AM-M77T-40 (E,V)
5	BT-351027	△ TRANS POWER AM-M77T-50 (B,S)
6	BT-351022	△ TRANS POWER AM-M77T-70 (U)
7	ED-200749	△ D SILICON DBA60-K15 400/6.0A
8	ED-337153 N	D SILICON H DS446FA5 F10
9	ED-301911	D SILICON H DS448
10	ED-345149 N	D ZENER H HZ15L 3
11	ED-346580 N	D ZENER H HZ27L 2
12	ED-346448 N	D ZENER H HZ6FA F10 A2
13	ED-343410 N	D ZENER H HZ6L A1
14	ED-307690 N	D ZENER H HZ7L A1
15	EF-601301	△ FUSE SEMKO T 250V 2.00A
16	EF-249851	△ FUSE SEMKO T 250V 5.00A
17	EF-306951	△ FUSE TSC A 250V 2.50A
18	EF-326613	△ FUSE TSC A 250V 5.00A
19	EF-346139	△ FUSE TSC 125V 5.00A
20	EI-343390	△ IC STK1050
21	EI-323563	△ IC STK3042
22	EI-349395	IC *A2028
23	EI-345474	IC HA12002
24	EI-345765	IC LB1292
25	EI-345479	IC LC7910
26	EI-337228	IC M5218L0
27	EI-349719	IC M5218P
28	EI-344764	IC M5218P-21
29	EI-343371	IC TC9154P
30	EI-343373	IC TC9156P
31	EI-349392	IC TC9164N
32	EI-330256	OSC CE F85-006 4MHz
33	EJ-349415	PHONE J 2P H5J0842-210 3.5 1C
34	EI-349390	PHONE J 2P H5J0944-040 3.5 2T
35	EJ-349391	PHONE J 3P H5J0942-040 3.5
36	EJ-336905	PIN J AJC-035-ACB P 4P
37	EJ-336915	PIN J AJC-054-ABB P 4P
38	EJ-350918	PLUG CONNECTER M1690 12P
39	JE-349401	TERMINAL LEVER YKD21-0027 8P
40	EM-349394	IND FL BG-217ZK DOUBLE
41	EQ-337159	RELAY SIGNAL G4Z-2282P 2NO 24V
42	ER-354396 N	△ R CB H FS RDS 1/4W 560J
43	ER-319455 N	△ R FUSE ERD2FC S10 1/4W 10R0G
44	ER-328520 N	△ R FUSE ERD2FC 1/4W 1000G
45	ES-349070	△ SW SELECT YKS11-0002 02-4
46	ES-349400	SW PUSH SUL211S 2 THROW
47	ES-345470	SW TACT KEC10901
48	ES-336780	SW TACT KHH10902
49	ES-305463	TR 2SA970 GR,BL
50	ET-347026	TR 2SB507HP E,F
51	ET-318237	TR 2SB764 E,F
52	ET-307195	TR 2SC2240 GR,BL
53	ET-349081	TR 2SC3383 S,T
54	ET-322775 N	TR 2SC536K-NP E,F,G
55	ET-452531 N	TR 2SD313HP E,F
56	ET-318239 N	TR 2SD863 E,F
57	EV-349402	VR SLIDE 30P15V0CB503

NOTE: "N" New Parts

## 1. MAIN P.C BOARD BLOCK

REF. NO.	PARTS NO.	DESCRIPTION
I-IU	BA-A2028A040A	PC MAIN BLK AM-M77 (U)
I-IC	BA-A2028A040C	PC MAIN BLK AM-M77 (C)
I-IE	BA-A2028A040D	PC MAIN BLK AM-M77 (E)
I-IV	BA-A2028A040E	PC MAIN BLK AM-M77 (V)
<b>MAIN AMP P.C BOARD</b>		
I-IC12	EI-323563	△ IC STK3042
I-IC13	EI-349719	IC M5218P
I-IC14	EI-345474	IC HA12002
I-TR4	ET-305463	TR 2SA970 GR,BL
I-TR5		
to TR7	ET-307195	TR 2SC2240 GR,BL
I-TR8	ET-305463	TR 2SA970 GR,BL
I-TR9	ET-452531	△ TR 2SD313HP E,F
I-TR10	ET-318239	△ TR 2SD863 E,F
I-TR11	ET-347026	△ TR 2SB507HP E,F
I-TR12	ET-318237	△ TR 2SB764 E,F
I-D20,		
D21	ED-301911	D SILICON H DS448
I-D24		
to D27	ED-301911	D SILICON H DS448
I-D28	ED-337153	D SILICON H DS446FA5 F10
I-D29	ED-200749	△ DSILICON DBA60-K15 400/6.0A
I-D30	ED-345149	△ D ZENER H HZ15L 3
I-D31	ED-707690	△ D ZENER H HZ7L A1
I-D32	ED-346580	△ D ZENER H HZ27L 2
I-D33	ED-345149	D ZENER H HZ15L 3
I-D34	ED-337153	△ D SILICON H DS446FA5 F10
I-RL1	EQ-337159	RELAY SIGNAL G4Z-2282P 2N) 24V
I-L10	EO-338420	COIL FIX 2 FL12R202F 202K (V)
I-L11		
to L13	EO-336934	COIL FIX 1 LAL03KH 2R2M (V)
I-L14	EO-337880	COIL FIX 2 202AK-018 2R2K
I-R90,		
R91	ER-325269	△ R CB H S10 FS RDS 1/4W 222J
I-R94	ER-341632	△ R OMF H SNP FS 1W 222J
I-R96,		
R97	ER-325269	△ R CB H S10 FS RDS 1/4W 222J
I-R105,		
R106	ER-308875	△ R CB H S15 FS RDS 1/2W 100J
I-R115	ER-351220	△ R OMF H S15 FS 1W 182J
I-R118	ER-333067	△ R OMF H S20 FS 2W 821J
I-R121,		
R123	ER-322787	△ R CB H S10 FS RDS 1/4W 100J
I-R125	ER-333625	△ R CB H S15 FS RDS 1/2W 180J
I-R128	ER-322787	△ R CB H S10 FS RDS 1/4W 100J
I-FR1,		
FR2	ER-328520	△ R FUSE ERD2FC 1/4W 1000G
I-FR3,		
FR4	ER-319455	△ R FUSE ERD2FC S10 1/4W 10R0G
I-C73	EC-333971	C EC V F05 NP SM 2R2M 501DC
I-C85,		
C86	EC-343393	C EC V CUT SM 103M 50.0DC
I-J17,J18	EJ-336905	PIN J AJC-035-ACB P 4P
I-F3U	EF-326613	△ FUSE TSC A 250V 5.00A (U)
I-F3J	EF-326613	△ FUSE TSC A 250V 5.00A (J)
I-F3C	EF-346139	△ FUSE TSC 125V 5.00A (C,A)
I-F3E	EF-249851	△ FUSE SEMKO T 250V 5.00A (E,V,B,S)
I-F4U	EF-326613	△ FUSE TSC A 250V 5.00A (U)
I-F4J	EF-326613	△ FUSE TSC A 250V 5.00A (J)
I-F4C	EF-346139	△ FUSE TSC 155V 5.00A (C,A)
I-F4E	EF-249851	△ FUSE SEMKO T 250V 5.00A (E,V,B,S)
<b>SPEAKER SWITCH P.C BOARD</b>		
I-SW16	ES-349400	SW PUSH SUL211S 2 THROW
<b>TERMINAL P.C BOARD</b>		
I-L15	EO-342936	COIL BALUN (V)
I-TM1	EJ-349401	TERMINAL LEVER YKD21-0027 8P

## 2. PRE AMP P.C BOARD BLOCK

REF. NO.	PARTS NO.	DESCRIPTION
2-1U	BA-A2028A060A	PC PRE AMP BLK AM-M77 (U) (EXCEPT V)
2-1V	BA-A2028A060B	PC PRE AMP BLK AM-M77 (V)
<b>PIN JACK P.C BOARD</b>		
2-SW1	ES-345470	SW TACT KEC10901
2-L1		
to L4	EO-336934	COIL FIX 1 LAL03KH 2R2M (V)
2-J1,J2	EJ-336915	PIN J AJC-054-ABB P 4P
2-J3		
to J5	EJ-349415	PHONE J 2P HSJ0842-210 3.5 1C
<b>SWITCH P.C BOARD</b>		
2-IC1	EI-344764	IC M5218P-21
2-IC2	EI-349392	IC TC9164N
2-D7,D8	ED-301911	D SILICON H DS448
2-C5	EC-316242	C EC V F05 SM 2R2M 50.0DC
2-C6	EC-346879	C PP V F05 PP 221J 50DC
2-C10	EC-315770	C EC V F05 SM 1R0M 50DC
2-C12,		
C13	EC-316242	C EC V F05 SM 2R2M 50.0DC
<b>VOLUME P.C BOARD</b>		
2-IC3	EI-343371	IC TC9154P
2-IC4,		
IC5	EI-343373	IC TC9156P
2-IC6	EI-337228	IC M5218L0
2-D1,D2	ED-343410	D ZENER H HZ61 A1
2-D3		
to D6	ED-301911	D SILICON H DS448
2-R20,		
R21	ER-200940	△ R CB H S10 FS RDS 1/4W 561J
2-C29	EC-349083	C STY V CUT CQ09S2B 101J 125DC
<b>SOCKET P.C BOARD</b>		
2-J28	EJ-351021	SOCKET CONNECTER M1688 12P
<b>PLUG P.C BOARD</b>		
2-J29	EJ-350918	PLUG CONNECTER M1690 12P

## 3. FLD P.C BOARD BLOCK

REF. NO.	PARTS NO.	DESCRIPTION
3-1	BA-A2028A080A	PC FLD BLK AM-M77 (U)
<b>FLD P.C BOARD</b>		
3-IC9	EI-349395	IC *A2028
3-IC10	EI-345479	IC LC7910
3-IC11	EI-345765	IC LB1292
3-TR2,		
TR3	ET-322775	TR 2SC536K-NP E,F,G
3-D10		
to D16	ED-301911	D SILICON H DS448
3-D17	ED-346448	D ZENER H HZ61A F10 A2
3-SW2		
to SW15	FS-336780	SW TACT KHH10902
3-VR1	FV-349402	VR SLIDE 30P1SV0C B503
3-X1	EI-330256	OSC CE F85-006 4MHZ
3-SR1	EH-349396	COMP R EXB-EQ7 472J
3-SR2	EH-349397	COMP R EXB-EQ6 104J
3-SR3	EH-349398	COMP R FXB-EQ4 472J
3-SR4	EH-349399	COMP R EXB-EQ8 104J
3-R75,		
R76	ER-354396	△ R CB H FS RDS 1/4W 560J (C)
3-C50	EC-344157	C DOUBLE LAYER 473Z 5.5DC
3-IND	EM-349394	IND FL BG-2137K DOUBLE

## 4. MIC AMP P.C BOARD BLOCK

REF. NO.	PARTS NO.	DESCRIPTION
<b>JACK P.C BOARD</b>		
4-L5	EO-338420	COIL FIX 2 FL12R202E 202K (V)
4-L6,L7	EO-336934	COIL FIX 1 LAL03KH 2R2M (V)
4-J11	EJ-349390	PHONE J 2P HSJ0944-040 3.5 2T
4-J12,		
J13	EJ-349391	PHONE J 3P HSJ0942-040 3.5
<b>MIC AMP P.C BOARD</b>		
4-IC8	EI-349719	IC M5218P
4-TR1	ET-349081	TR 2SC3383 S,T
4-R54	ER-313699	△ R OMF H FS 2W 221J

## 5. FUSE P.C BOARD BLOCK

REF. NO.	PARTS NO.	DESCRIPTION
5-F1I	EO-338409	COIL LF FKOB 160MH02 250UH (V)
5-F1U	EF-306951	△ FUSE TSC A 250V 2.50A (U)
5-F1J	EF-326613	△ FUSE TSC A 250V 5.00A (J)
5-F1C	EF-346139	△ FUSE TSC 125V 5.00A (C,A)
5-F1E	EF-601301	△ FUSE SEMKO T 250V 2.00A (F,V,B,S)
5-F2U	EF-306951	△ FUSE TSC A 250V 2.50A (U)



## ASSEMBLY BLOCK

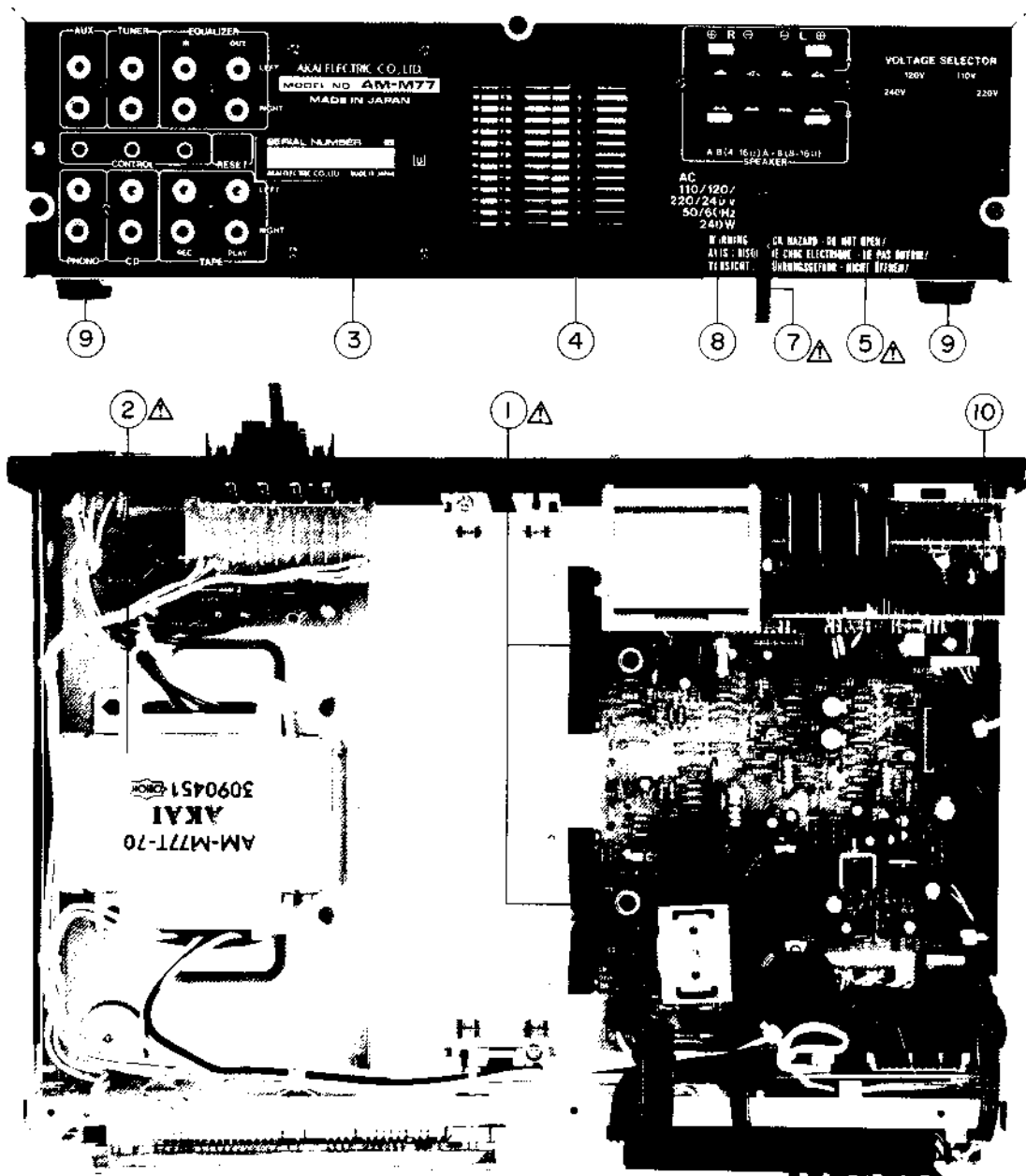

### 6. ASSEMBLY BLOCK

REF. NO.	PARTS NO.	DESCRIPTION	REF. NO.	PARTS NO.	DESCRIPTION
6-1	EI-343390	△ IC STK1050 (IC901)	6-3B	SP-350887C	PANEL REAR AM-M77 (B,S)
6-2U	BT-351022	△ TRANS POWER AM-M77T-70 (U) (T901)	6-4	ZS-308846	T2BR30x08STL BZN PROJECTION
6-2J	BT-351023	△ TRANS POWER AM-M77T-10(J) (T901)	6-5	ES-349070	△ SW SELECT YKS11-0002 02-4 (U)
6-2C	BT-351024	△ TRANS POWER AM-M77-30 (C) (T901)	6-6x	FJ-301513	SOCKET INLET S-16453 E 2P (E,V,B,S)
6-2A	BT-351025	△ TRANS POWER AM-M77T-20 (A) (T901)	6-7U	EW-349434	△ AC CORD 2 CORES KP-124,VFF AM-7 U/T (U)
6-2E	BT-351026	△ TRANS POWER AM-M77T-40 (E,V) (T901)	6-7J	EW-349435	△ AC CORD 2 CORES KP-224, VFF AM-7 J (J)
6-2B	BT-351027	△ TRANS POWER AM-M77T-50 (B,S) (T901)	6-7C	EW-325237	△ AC CORD 2 CORES KP-8, SPT-2 UC (C)
6-3U	SP-350887A	PANEL REAR AM-M77 (U)	6-7A	EW-305691	△ AC CORD 2 CORES KP-8, SPT-1 UC (A)
6-3J	SP-350887E	PANEL REAR AM-M77 (J)	6-8	EZ-631945	STRAIN RELIEF SR-4N-4 (U,J,C,A)
6-3C	SP-350887D	PANEL REAR AM-M77 (C,A)	6-9	SA-202118	FOOT
6-3E	SP-350887B	PANEL REAR AM-M77 (E,V)	6-10	ZW-698308	RV NYL30x055 BL

PARTS LIST AM-M77

## FINAL ASSEMBLY BLOCK

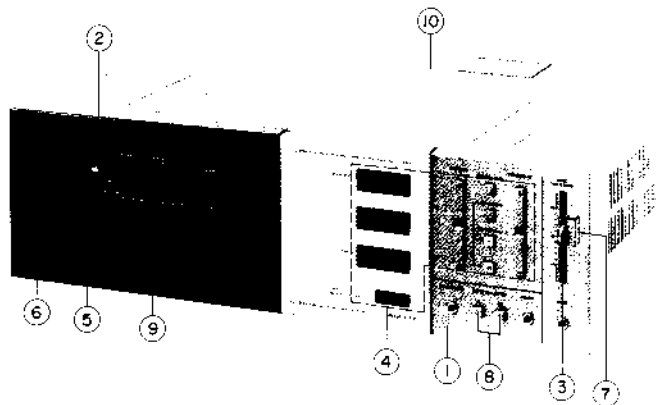

### 7. FINAL ASSEMBLY BLOCK

REF. NO.	PARTS NO.	DESCRIPTION	REF. NO.	PARTS NO.	DESCRIPTION
7-1U	BD-A2028A090A	PANEL FRONT BLK AM-M77 (U) (EXCEPT A)	7-6	SK-350884	KNOB BALANCE
7-1A	BD-A2028A090B	PANEL FRONT BLK AM-M77 (A)	7-7	SK-350880	HOLDER KNOB
7-2	SP-350888	PANEL WINDOW	7-8	SK-350877	KNOB PUSH
7-3	SK-350881	KNOB SLIDE (B)	7-9	FV-349403	VR TACH SENSOR ASSY B153
7-4	SA-350885	KNOB RUBBER (UL)	7-10	SP-350869	COVER UPPER
7-5	SK-350883	KNOB SAFETY	7-11x	ZW-305013	RV POP32 (A)

## INDEX

PARTS NO.	REF. NO.	PARTS NO.	REF. NO.	PARTS NO.	REF. NO.	PARTS NO.	REF. NO.	PARTS NO.	REF. NO.
BA-A2028A040A	1-1U	ED-301911	3-D11	EI-345474	1-IC14	FR-308875	1-R106	ET-307195	1-TR7
BA-A2028A040C	1-1C	ED-301911	3-D12	EI-345479	3-IC10	ER-313699	4-R54	ET-318237	1-TR12
BA-A2028A040D	1-1E	ED-301911	3-D13	EI-345765	3-IC11	FR-319455	1-FR3	ET-318239	1-TR10
BA-A2028A040E	1-1V	ED-301911	3-D14	EI-349392	2-IC2	FR-319455	1-FR4	ET-322775	3-TR2
BA-A2028A060A	2-1U	ED-301911	3-D15	EI-349395	3-IC9	ER-322787	1-R121	ET-322775	3-TR3
BA-A2028A060B	2-1V	ED-301911	3-D16	EI-349719	1-IC13	FR-322787	1-R123	ET-347026	1-TR11
BA-A2028A080A	3-1	ED-307990	1-D31	EI-349719	4-IC8	ER-322787	1-R128	ET-349081	4-TR1
BD-A2028A090A	7-1U	ED-337153	1-D28	EJ-301513	6-6x	ER-325269	1-R90	ET-452531	1-TR9
BD-A2028A090B	7-1A	ED-337153	1-D34	EJ-336905	1-J17	ER-325269	1-R91	EV-349402	3-VR1
BT-351022	6-2U	ED-343410	2-D1	EJ-336905	1-J18	FR-325269	1-R96	EV-349403	7-9
BT-351023	6-2J	ED-343410	2-D2	EJ-336915	2-J1	ER-325269	1-R97	EW-305691	6-7A
BT-351024	6-2C	ED-345149	1-D30	EJ-336915	2-J2	ER-328520	1-FR1	EW-349434	6-7U
BT-351025	6-2A	ED-345149	1-D33	EJ-349390	4-J11	FR-328520	1-FR2	FW-349435	6-7J
BT-351026	6-2E	ED-346448	3-D17	EJ-349391	4-J12	ER-333067	1-R118	EW-352237	6-7C
BT-351027	6-2B	ED-346580	1-D32	EJ-349391	4-J13	ER-333625	1-R125	EZ-631945	6-8
EC-315770	2-C10	EF-249851	1-F3E	EJ-349401	1-TM1	FR-341632	1-R94	SA-202118	6-9
EC-316242	2-C5	EF-249851	1-F4E	EJ-349415	2-J3	FR-351220	1-R115	SA-350885	7-4
EC-316242	2-C12	EF-306951	5-F1U	EJ-349415	2-J4	ER-354396	3-R75	SK-350877	7-8
EC-316242	2-C13	EF-306951	5-F2U	FJ-349415	2-J5	FR-354396	3-R76	SK-350880	7-7
EC-333971	1-C73	EF-326613	1-F3U	EJ-350918	2-J29	FS-336780	3-SW2	SK-350881	7-3
EC-333971	1-C74	EF-326613	1-F3J	EJ-351021	2-J28	FS-336780	3-SW3	SK-350883	7-5
EC-343393	1-C85	EF-326613	1-F4U	EM-349394	3-IND	FS-336780	3-SW4	SK-350884	7-6
EC-343393	1-C86	EF-326613	1-F4J	EO-336934	1-L11	ES-336780	3-SW5	SP-350869	7-10
EC-344157	3-C50	EF-326613	5-F1J	EO-336934	1-L12	ES-336780	3-SW6	SP-350887A	6-3U
EC-346879	2-C6	EF-346139	1-F3C	EO-336934	1-L13	ES-336780	3-SW7	SP-350887B	6-3E
EC-349083	2-C29	EF-346139	1-F4C	EO-336934	2-L1	ES-336780	3-SW8	SP-350887C	6-3B
ED-200749	1-D29	EF-346139	5-F1C	EO-336934	2-L2	FS-336780	3-SW9	SP-350887D	6-3C
ED-301911	1-D20	EF-601301	5-F1E	EO-336934	2-L3	FS-336780	3-SW10	SP-350887E	6-3J
ED-301911	1-D21	EH-349396	3-SR1	EO-336934	2-L4	ES-336780	3-SW11	SP-350888	7-2
ED-301911	1-D24	EH-349397	3-SR2	EO-336934	4-L6	ES-336780	3-SW12	ZS-308846	6-4
ED-301911	1-D25	EH-349398	3-SR3	EO-336934	4-L7	FS-336780	3-SW13	ZW-305013	7-11x
ED-301911	1-D26	EH-349399	3-SR4	EO-337880	1-L14	ES-336780	3-SW14	ZW-698308	6-10
ED-301911	1-D27	EI-323563	1-IC12	EO-338409	5-FL1	ES-336780	3-SW15		
ED-301911	2-D3	EI-330256	3-X1	EO-338420	1-L10	ES-345470	2-SW1		
ED-301911	2-D4	EI-337228	2-IC6	EO-338420	4-L5	FS-349070	6-5		
ED-301911	2-D5	EI-343371	2-IC3	EO-342936	1-L15	FS-349400	1-SW16		
ED-301911	2-D6	EI-343373	2-IC4	EQ-337159	1-RL1	ET-305463	1-TR4		
ED-301911	2-D7	EI-343373	2-IC5	ER-200940	2-R20	ET-305463	1-TR8		
ED-301911	2-D8	EI-343390	6-1	ER-200940	2-R21	ET-307195	1-TR5		
ED-301911	3-D10	EI-344764	2-IC1	ER-308875	1-R105	ET-307195	1-TR6		

---

**AKAI**

**MODEL AM-M77**

**P.C. BOARD  
SCHEMATIC DIAGRAM**

**A2028 (MICRO PROCESSER)**

Pin NO.	Terminal Description	Function	Pin NO.	Terminal Description	Function
1	DIGIT0	STROB for the key matrix and Dinamic FL Display.	22	Seg. 8	Segment data for the Dinamic FL Display.
2	DIGIT1		23	Seg. 9	
3	DIGIT2		24	Seg. 10	
4	DIGIT3		25	Seg. 11	
5	DIGIT4		26	K0	
6	Not used	27	K1		
7	Seg. 12	28	K2		
8	Seg. 13	29	K3		
9	Seg. 0	Segment Data for the Dinamic FL Display.	30	TEST	Terminal for the X'tal (OSC)
10	1		31	XIN	
11	2		32	XOUT	
12	3		33	RST	
13	Data	For the Control Data of INPUT SELECTOR Analogue SW and VOLUME (TC9156P, TC9154P)	34	HOLD	HOLD Input
14	CK		35		Not used
15	ST	STROB for VOLUME Control	36	CB out	Common Bus output
16	ST	STROB for INPUT SELECTOR Control	37	CB in	Common Bus input
17	Seg. 4	Segment Data for the Dinamic FL Display.	38		End detection of A/D convertor (LC7910)
18	Seg. 5		39		Data detection of A/D convertor (LC7901)
19	Seg. 6		40		Com and out of bigining A/D conversion, for the A/D convertor
20	Seg. 7		41	CE	Data Receive Clock of the A/D convertor (LC7910)
21	VSS	GND	42	VDD	+5V

M5218L0

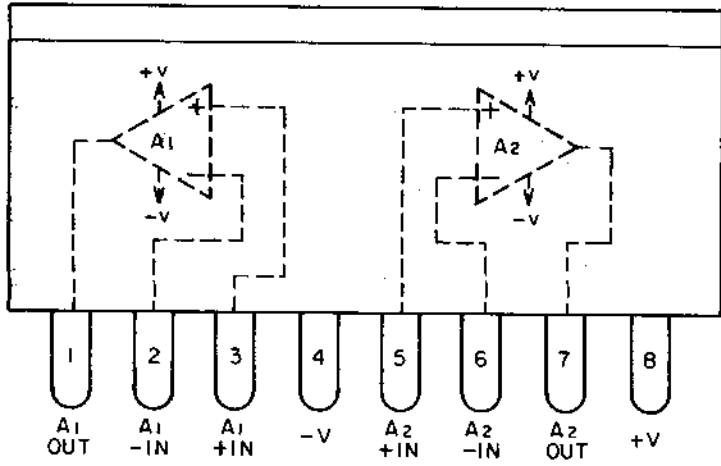

M5218L0

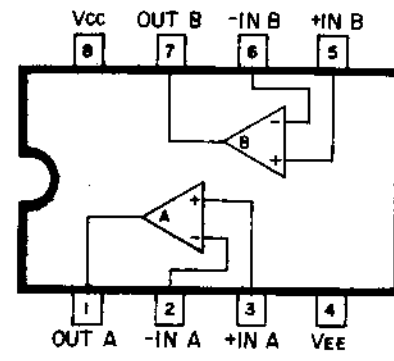

STK1050

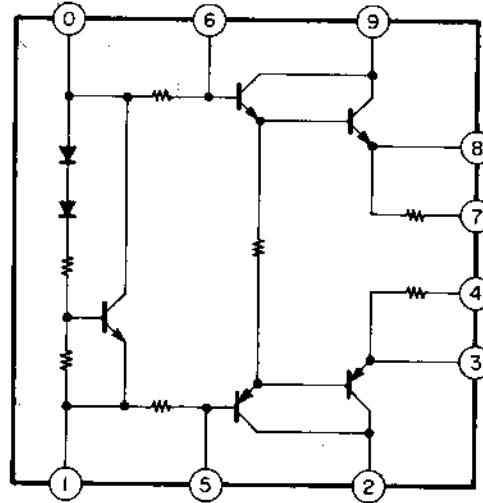

STK3042 (2CH. AF VOLTAGE AMP)

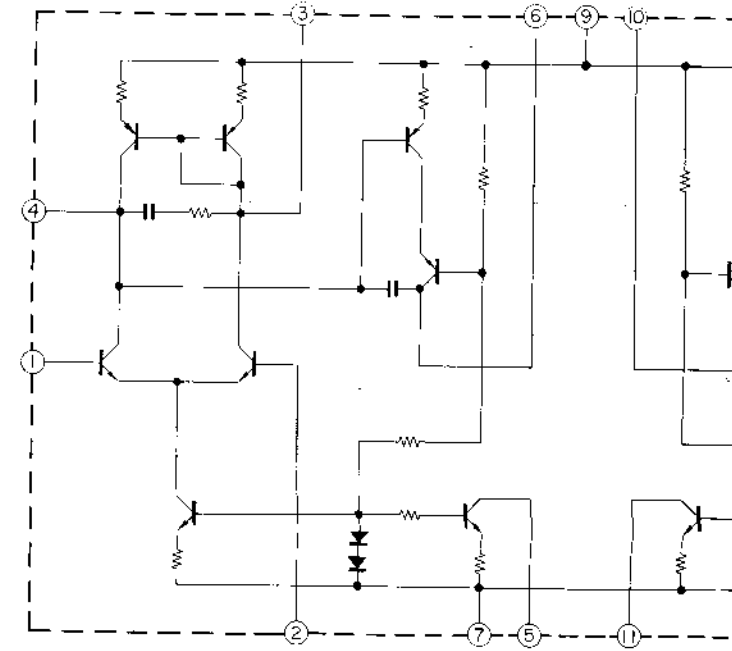

TC9154P

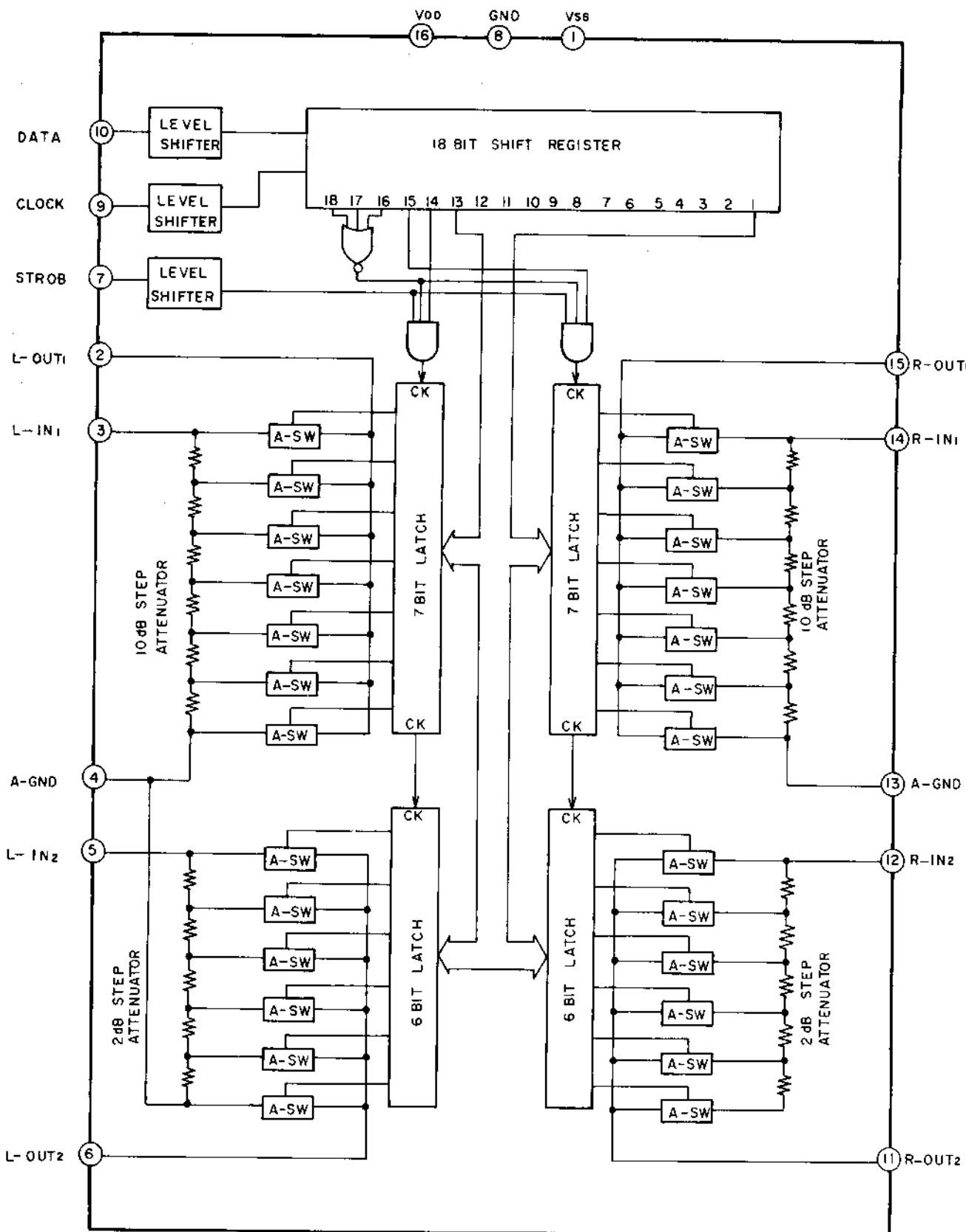

TC9156P

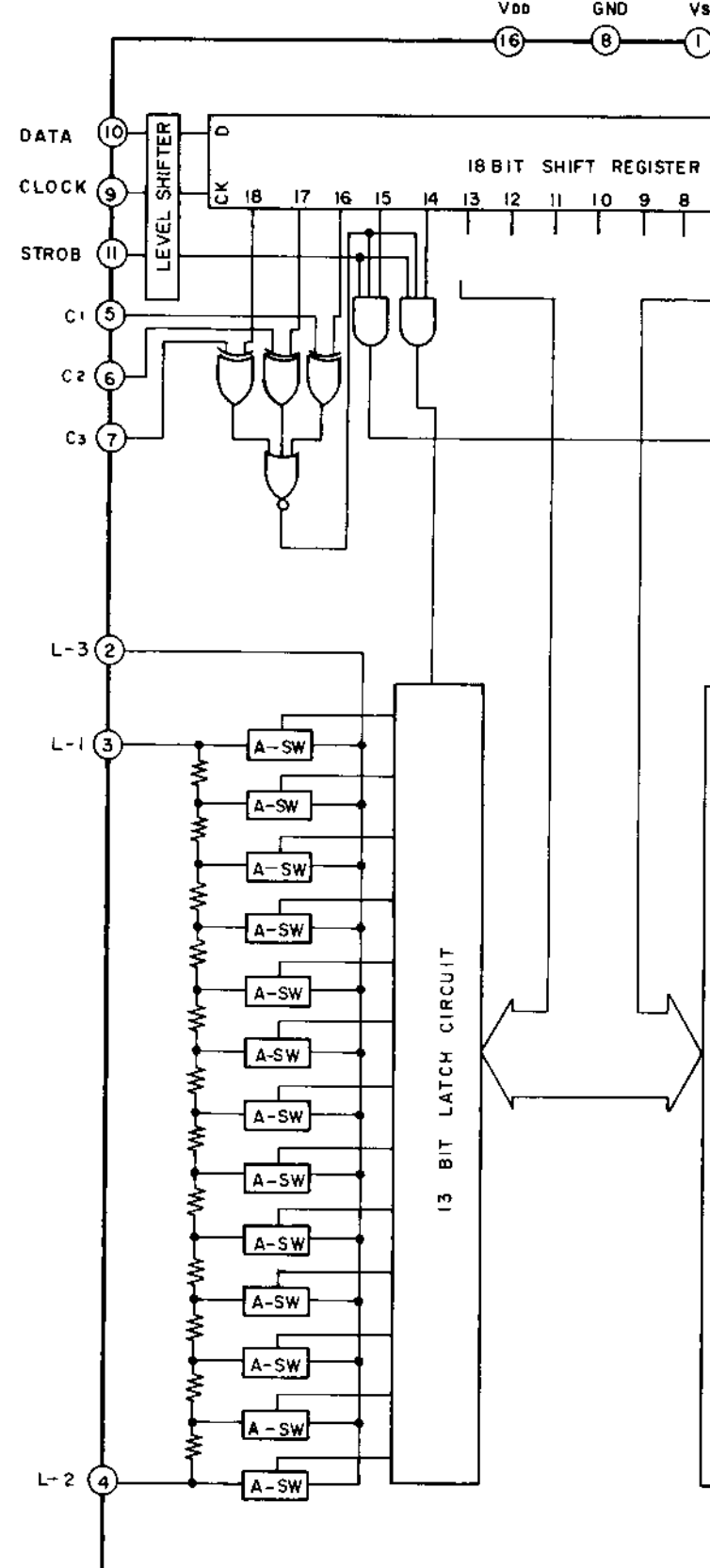

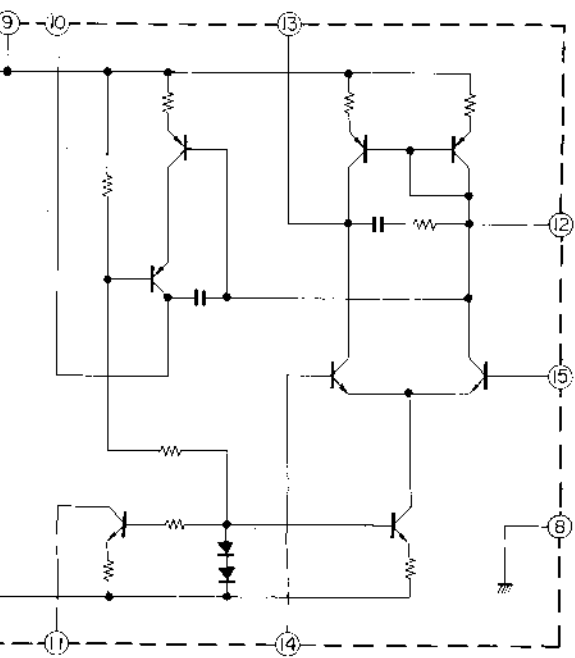

STK 4833

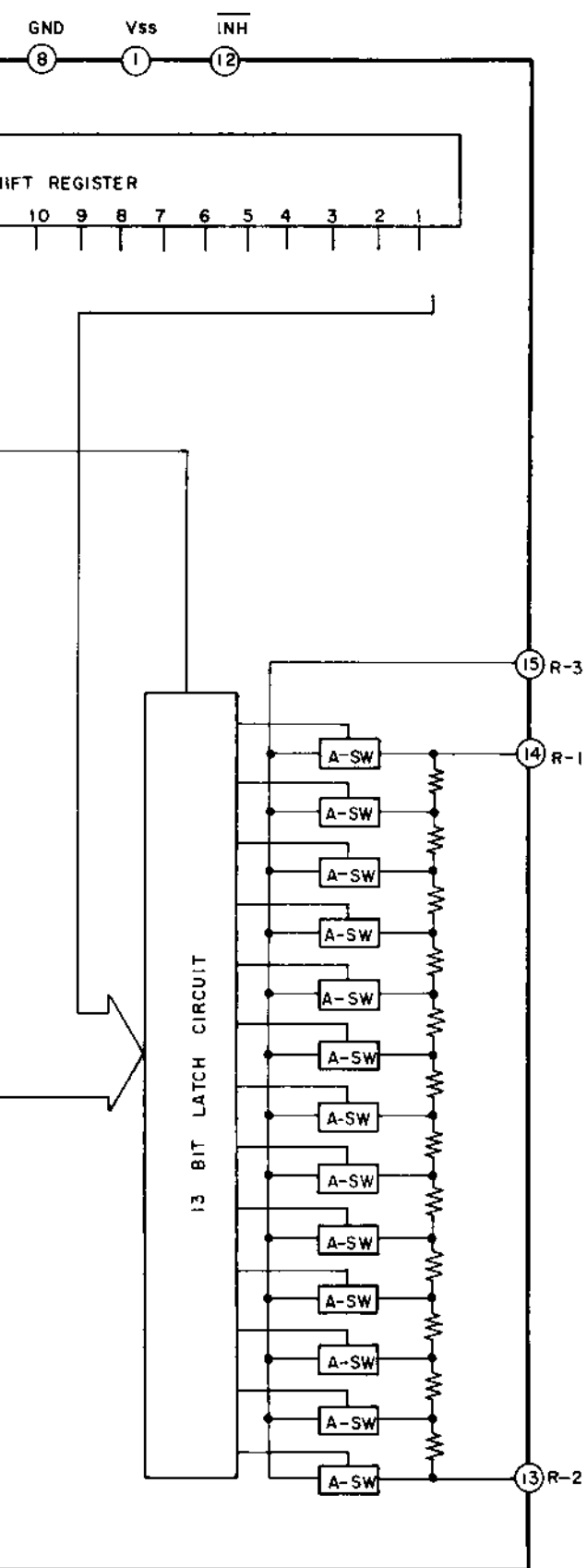
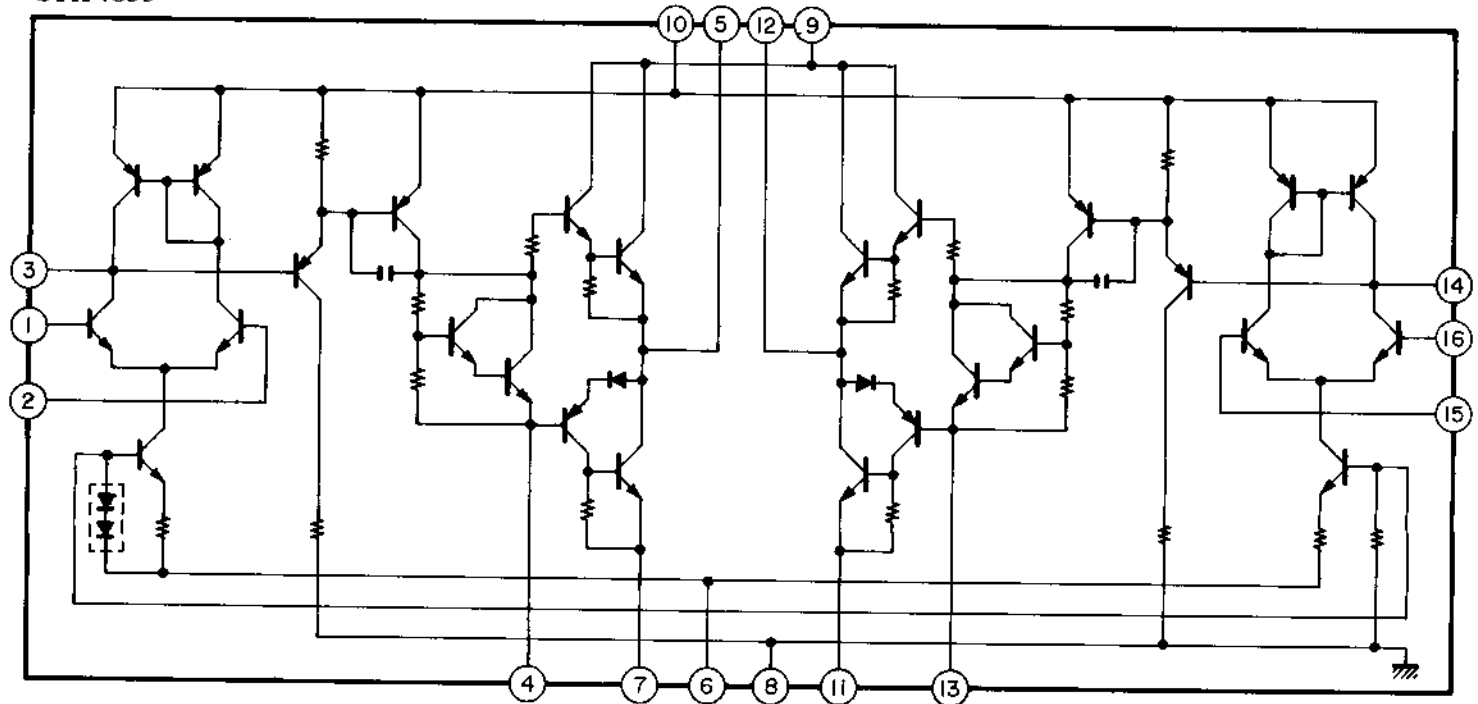

### BLOCK DIAGRAM

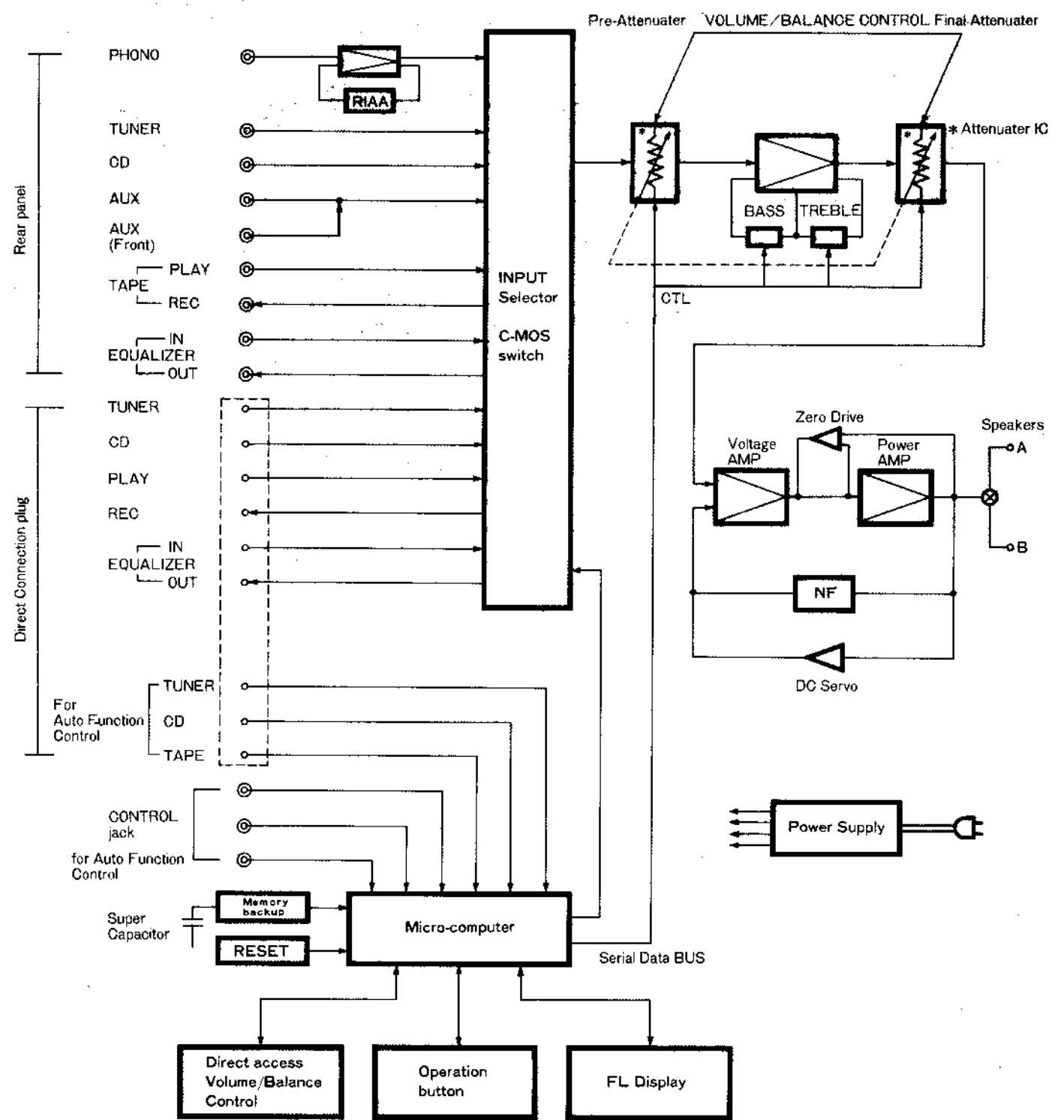

AM-M77

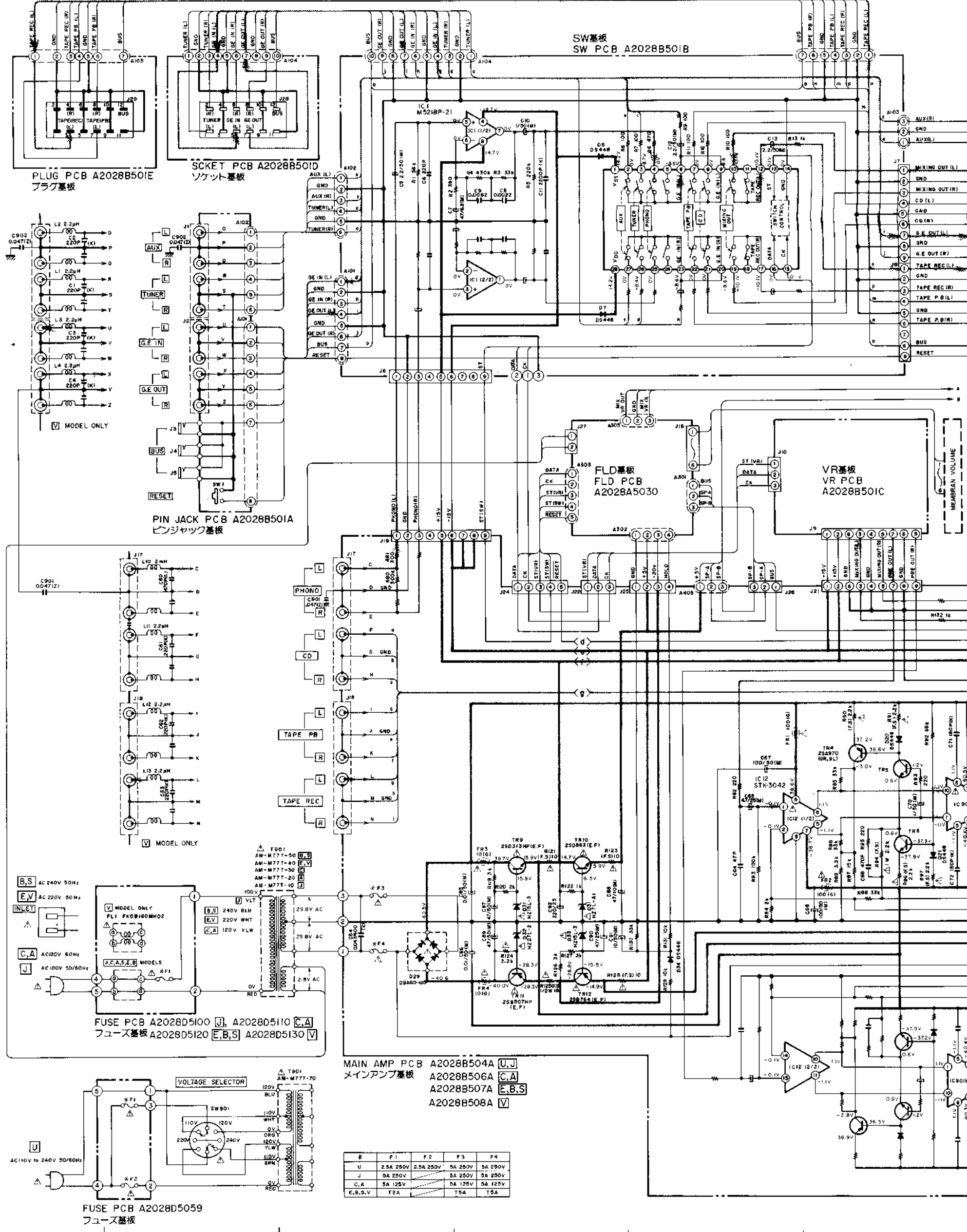

F	F1	F2	F3	F4
U	2.5A 250V	2.5A 250V	5A 250V	5A 250V
J	5A 250V	5A 250V	5A 250V	5A 250V
C,A	5A 125V	5A 125V	5A 125V	5A 125V
E,B,S,V	T2A	T5A	T5A	T5A

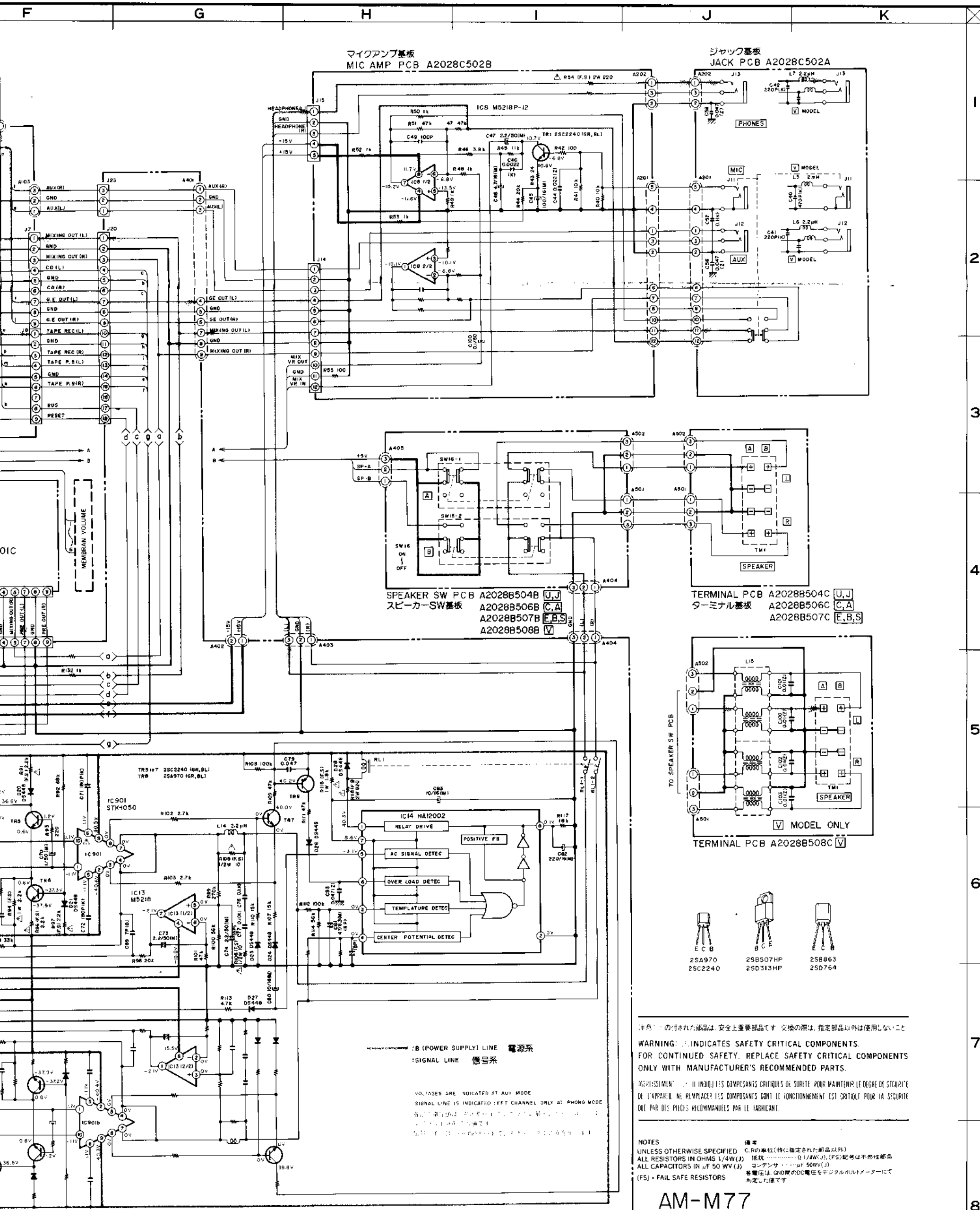

注意：この付された部品は、安全上重要部品です。交換の際は、指定部品以外は使用しないこと

**WARNING:** ⚠ INDICATES SAFETY CRITICAL COMPONENTS. FOR CONTINUED SAFETY, REPLACE SAFETY CRITICAL COMPONENTS ONLY WITH MANUFACTURER'S RECOMMENDED PARTS.

**REQUISITION:** ⚠ II INDIQUE LES COMPOSANTS CRITIQUES DE SURETE POUR MAINTENIR LE DEGRE DE SECURITE DE L'APPAREIL. NE REMPLACEZ LES COMPOSANTS QUI LE FONCTIONNEMENT EST CRITIQUE POUR LA SECURITE OUT PAR DES PIECES RECOMMANDEES PAR LE FABRICANT.

**NOTES**  
UNLESS OTHERWISE SPECIFIED, C, R の単位 (特に指定された部品以外)  
ALL RESISTORS IN OHMS 1/4W (J) 抵抗 ..... Q 1/4W (J), (FS) 記号は不燃性部品  
ALL CAPACITORS IN μF 50 WV (J) コンデンサ ..... F 50WV (J)  
(FS) = FAIL SAFE RESISTORS 各電圧は、GND 側の DC 電圧をデジタルオシロスコープにて測定した値です

**AM-M77**  
**CONNECTION DIAGRAM**  
NO. 2-1 840323A

1  
2  
3  
4  
5  
6  
7  
8



マイク アンプ基板  
MIC AMP PCB A2028C502B

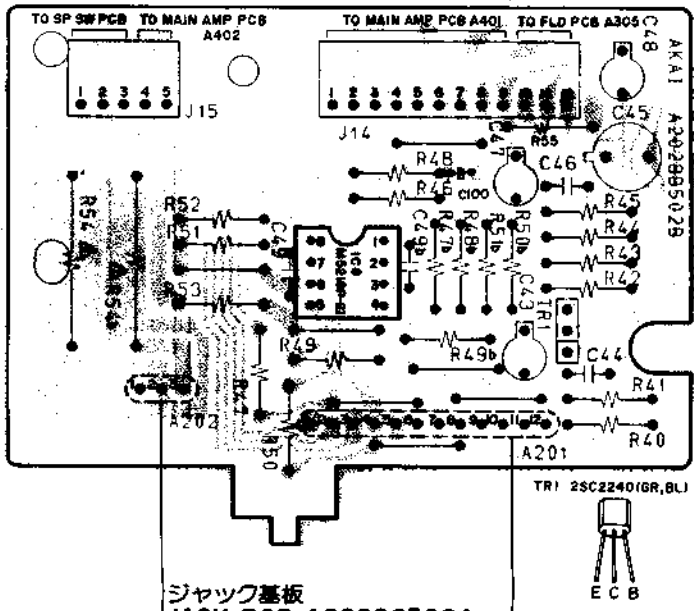

ジャック基板  
JACK PCB A2028B502A

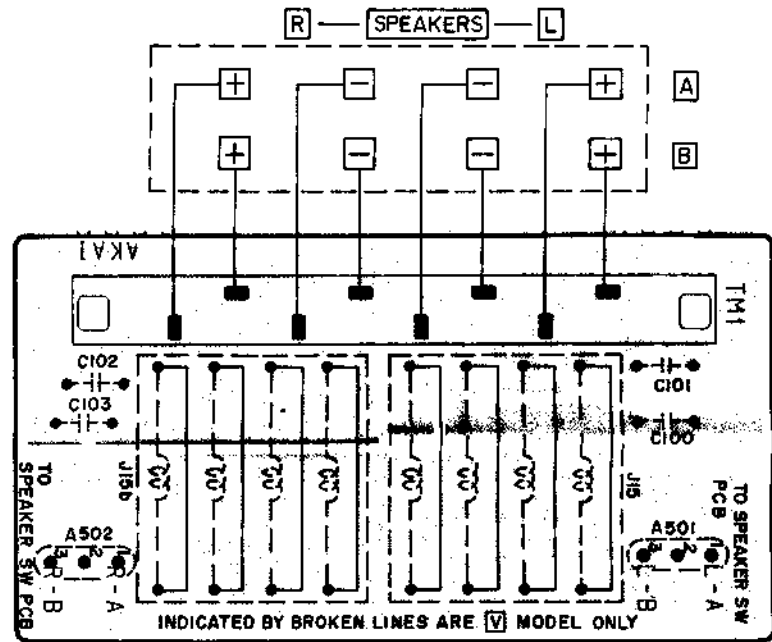
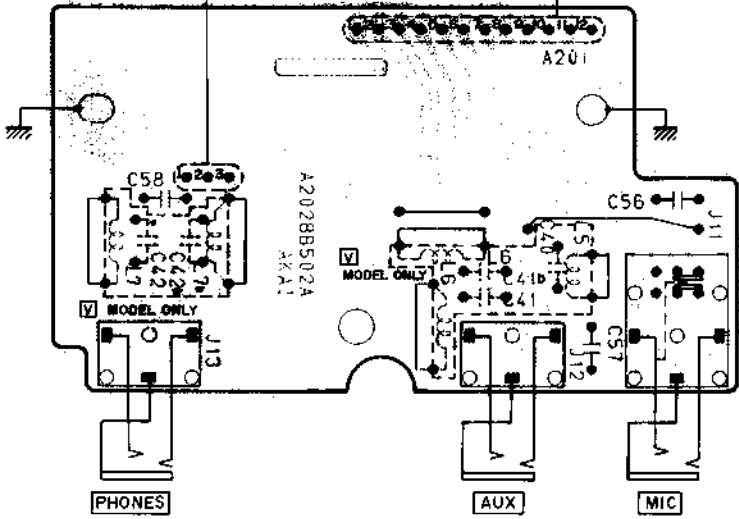

- TERMINAL PCB A2028B504C [J,U]  
ターミナル基板 A2028B506C [C,A]  
A2028B507C [E,B,S]  
A2028B508C [V]

LOCATION OF COMPONENTS

- | TRANSISTORS | TERMINALS  |
|-------------|------------|
| TR4-----B1  | J19-----B1 |
| TR4b-----B1 | J20-----B1 |
| TR5-----B1  | J21-----B1 |
| TR5b-----B1 | J22-----B1 |
| TR6-----B1  | J23-----B1 |
| TR6b-----B1 | J24-----B1 |
| TR7-----A2  | J25-----B2 |
| TR7b-----A1 | J26-----B2 |
| TR8-----A2  |            |
| TR9-----B2  |            |
| TR10-----B2 |            |
| TR11-----B2 |            |
| TR12-----B2 |            |
| IC'S        |            |
| IC12-----B1 |            |
| IC13-----B2 |            |
| IC14-----A1 |            |

メインアンプ基板  
MAIN AMP PCB A2028B504A [J,U]  
A2028B506A [C,A]  
A2028B507A [E,B,S]  
A2028B508A [V]

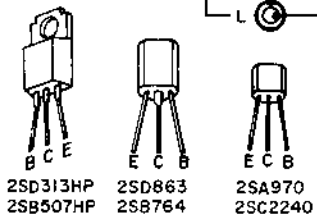
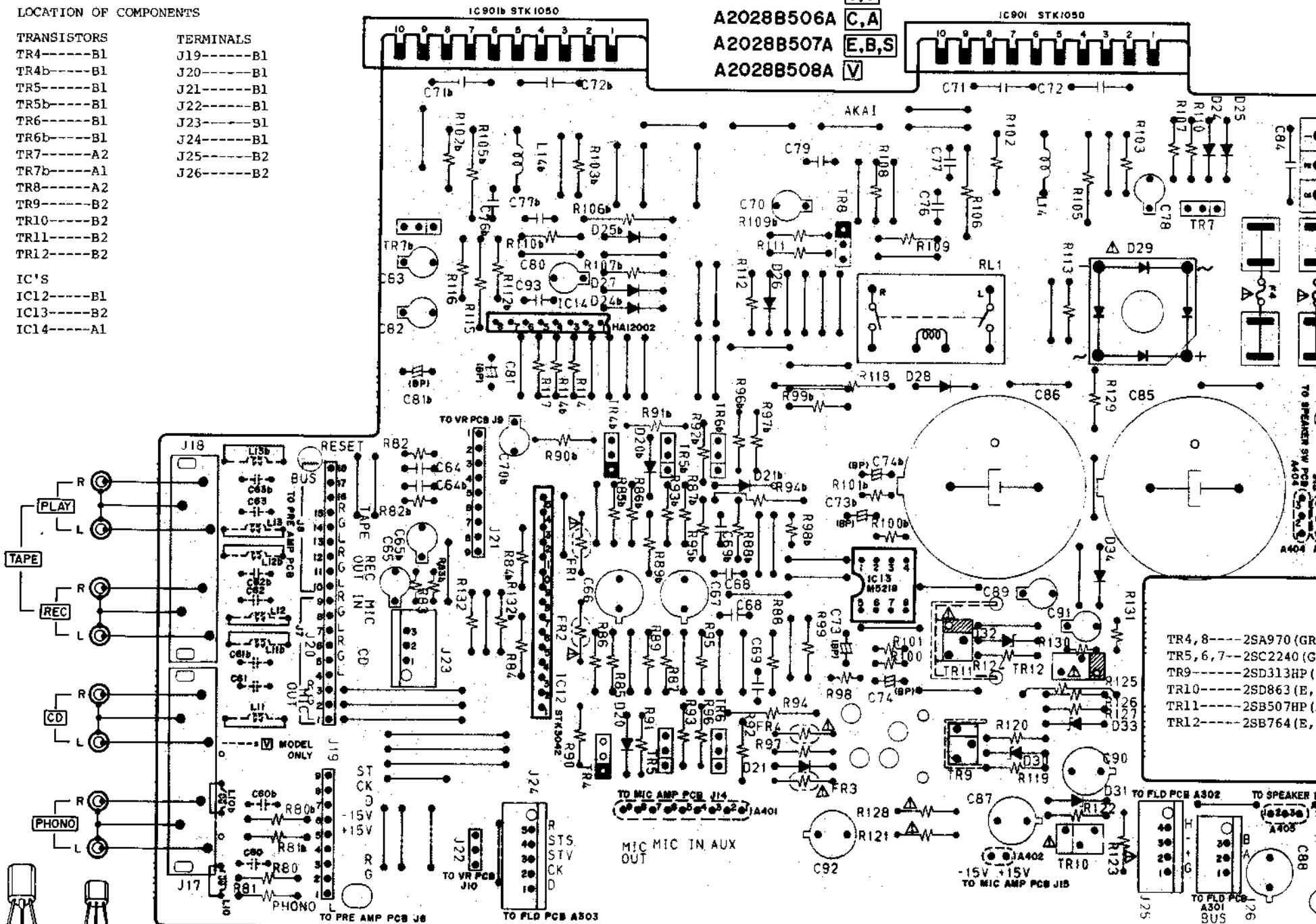

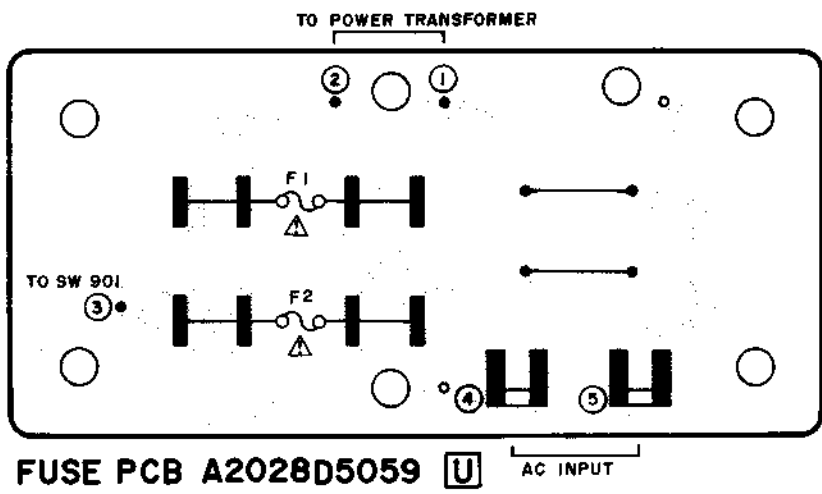

FUSE PCB A2028D5059 **U** AC INPUT

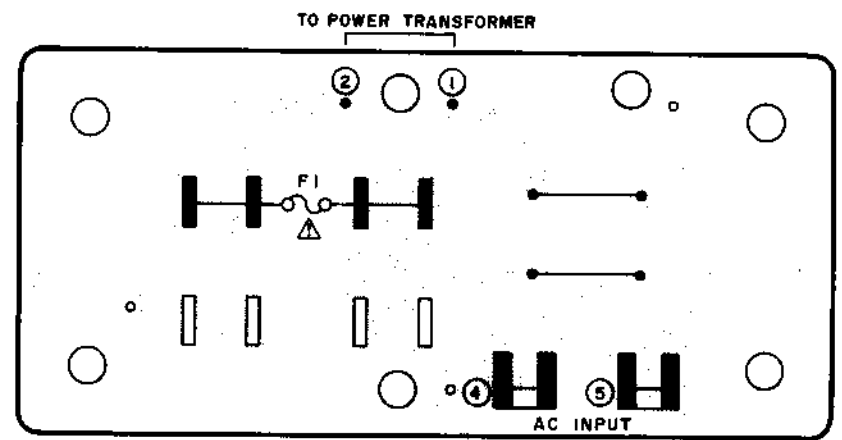

FUSE PCB A2028D5059 **J, E, B, S**  
フューズ基板

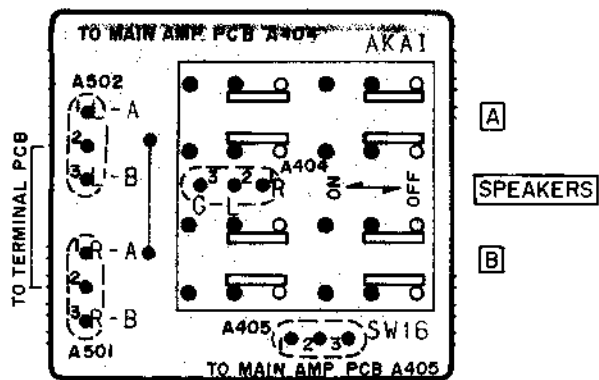

SPEAKER SW PCB A2028B504B **J, U**  
スピーカーSW基板  
A2028B506B **C, A**  
A2028B507B **E, B, S**  
A2028B508B **V**

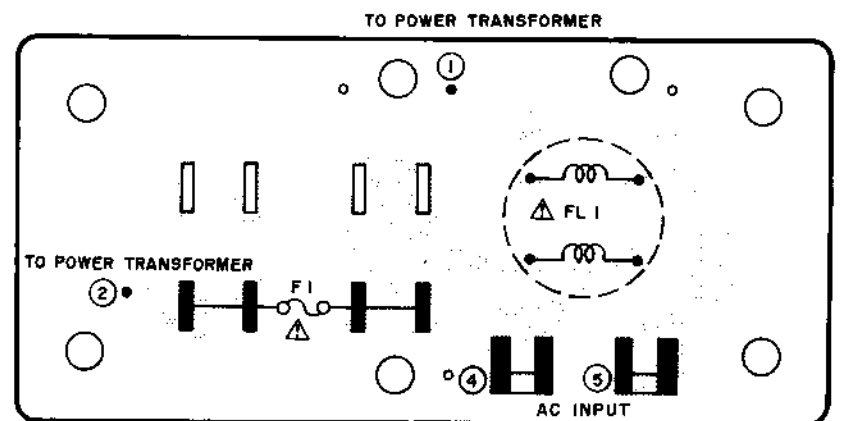

FUSE PCB A2028D5059 **V**

注意：△の付された部品は、安全上重要部品です。交換の際は、指定部品以外は使用しないこと。  
 WARNING: △ INDICATES SAFETY CRITICAL COMPONENTS. FOR CONTINUED SAFETY, REPLACE SAFETY CRITICAL COMPONENTS ONLY WITH MANUFACTURER'S RECOMMENDED PARTS.  
 AVERTISSEMENT: △ IL INDIQUE LES COMPOSANTS CRITIQUES DE SURETE. POUR MAINTENIR LE DEGRE DE SECURITE DE L'APPAREIL, NE REMPLACER LES COMPOSANTS BONT LE FONCTIONNEMENT EST CRITIQUE POUR LA SECURITE QUE PAR DES PIECES RECOMMANDEES PAR LE FABRICANT.

ソケット基板  
SOCKET PCB A2028B501E

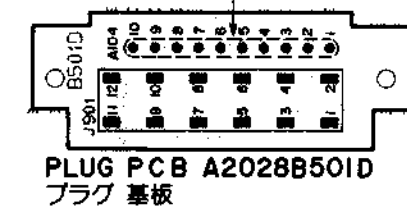
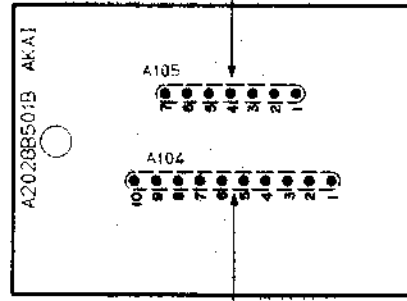
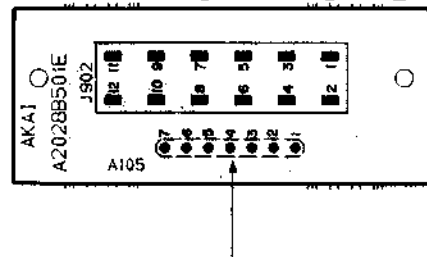

PLUG PCB A2028B501D  
プラグ基板

SW基板  
SW PCB A2028D501B

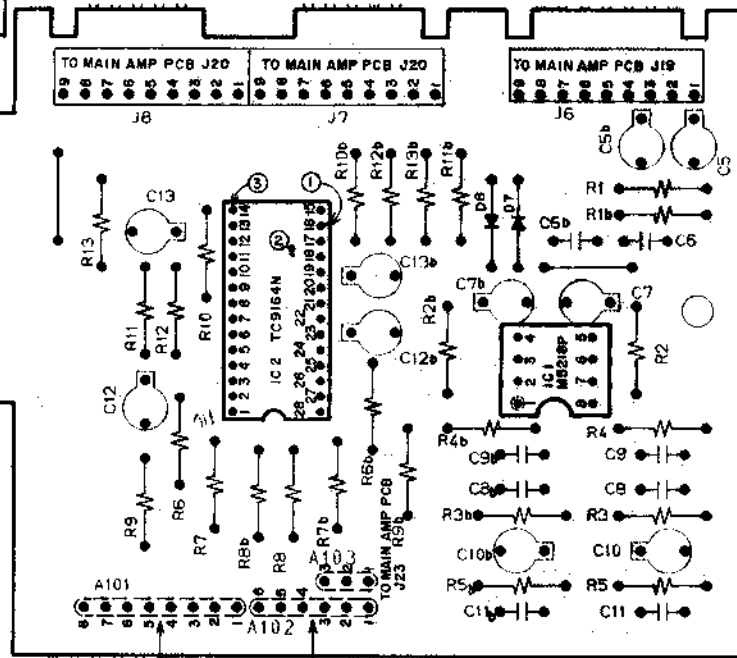

ピンジャック基板  
PIN JACK PCB A2028B501A

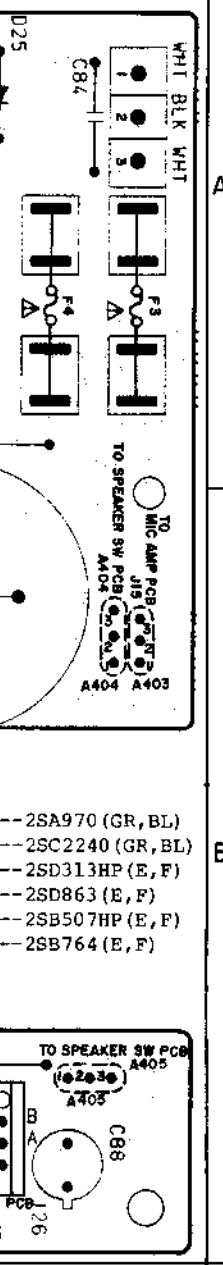
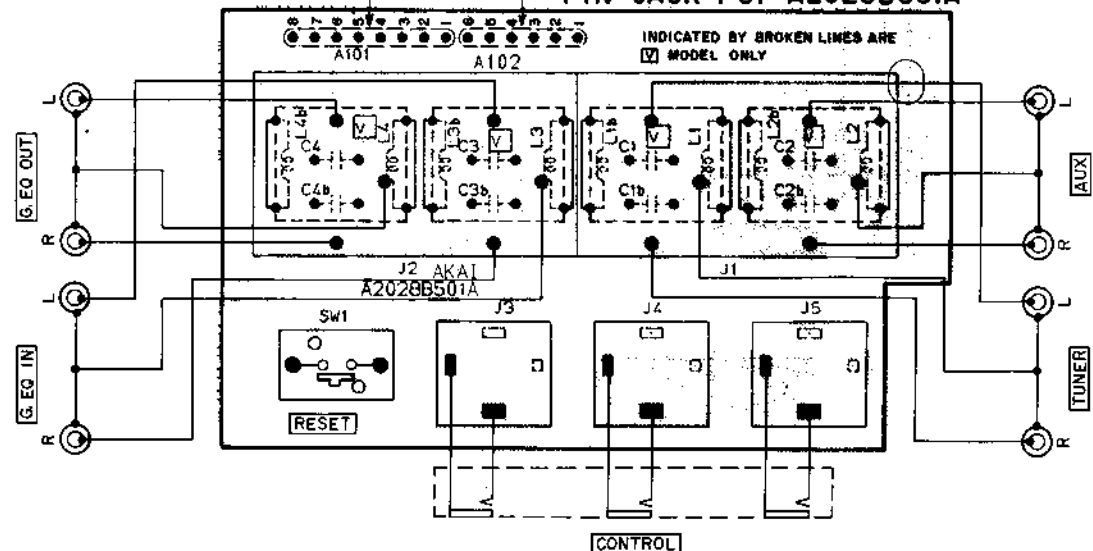

- 2SA970 (GR, BL)
- 2SC2240 (GR, BL)
- 2SD313HP (E, F)
- 2SD863 (E, F)
- 2SB507HP (E, F)
- 2SB764 (E, F)

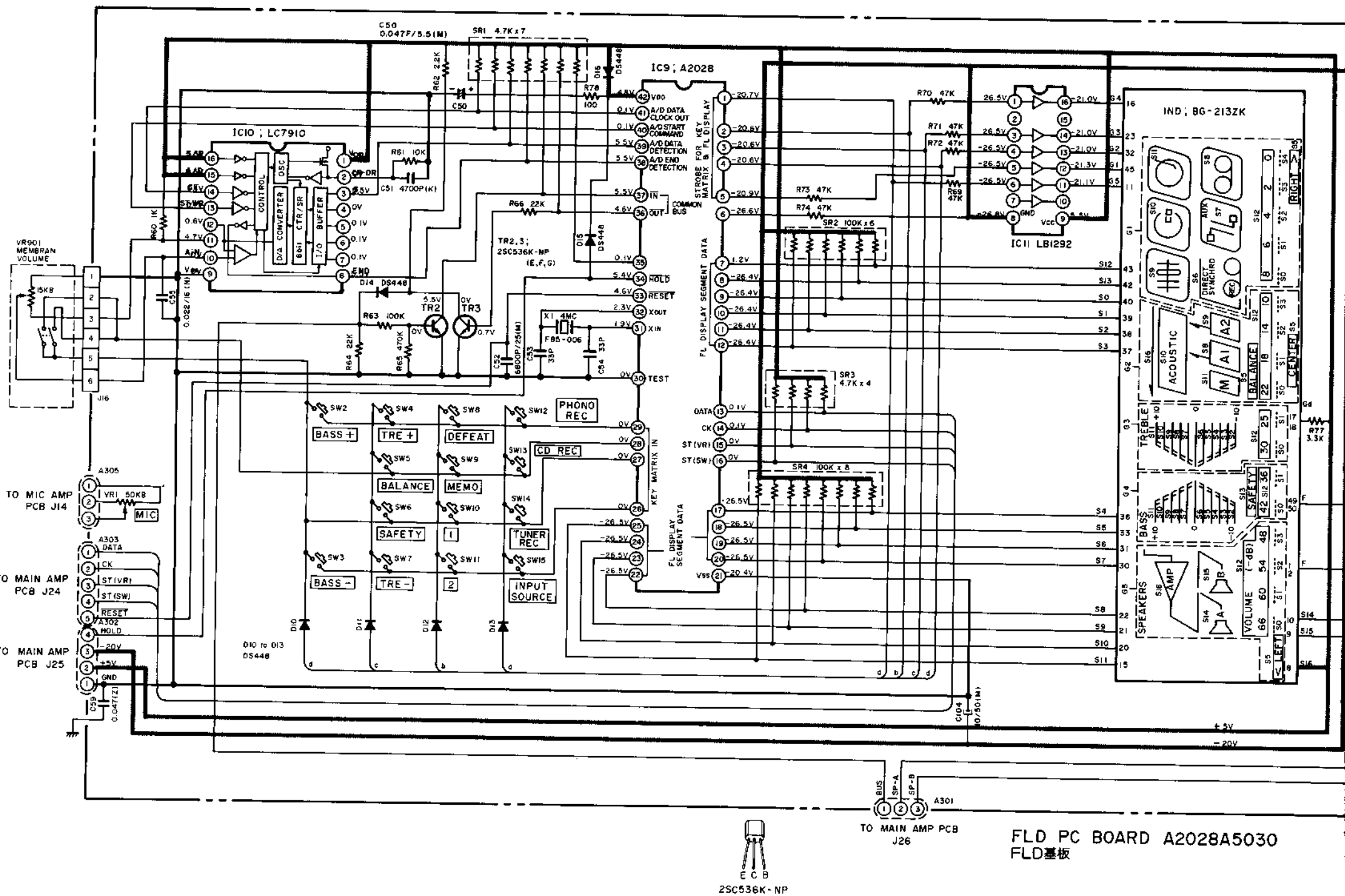
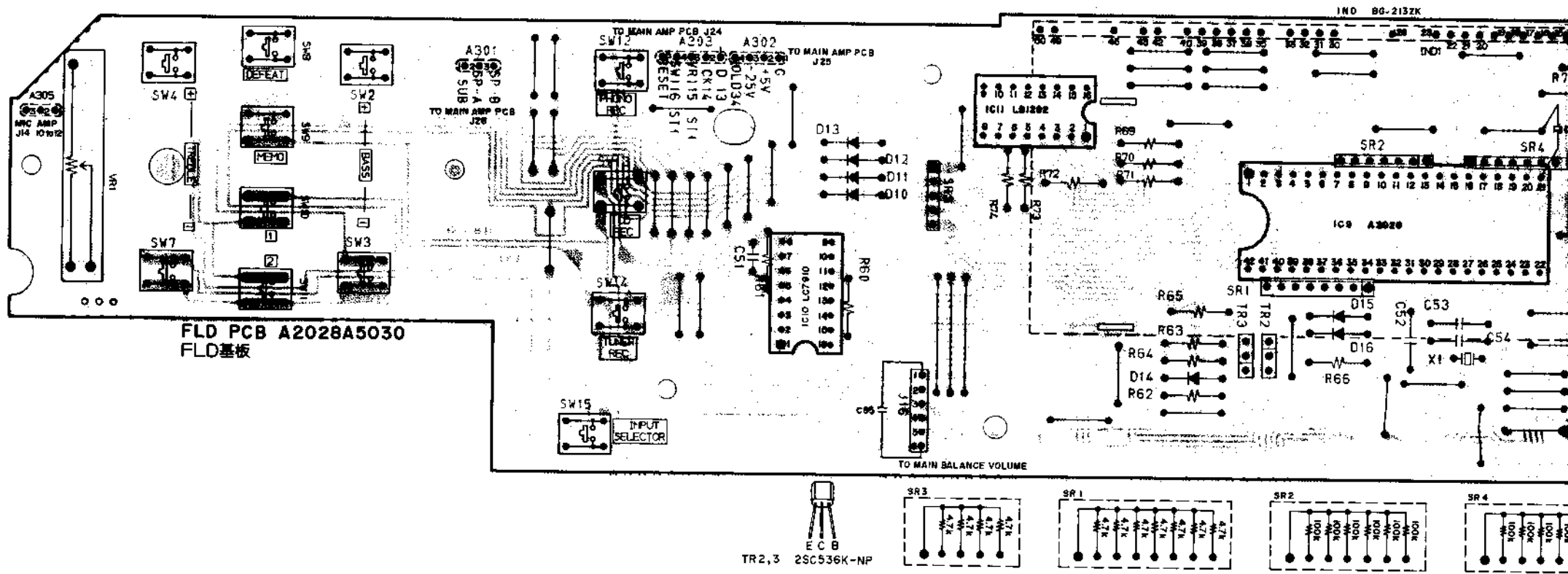

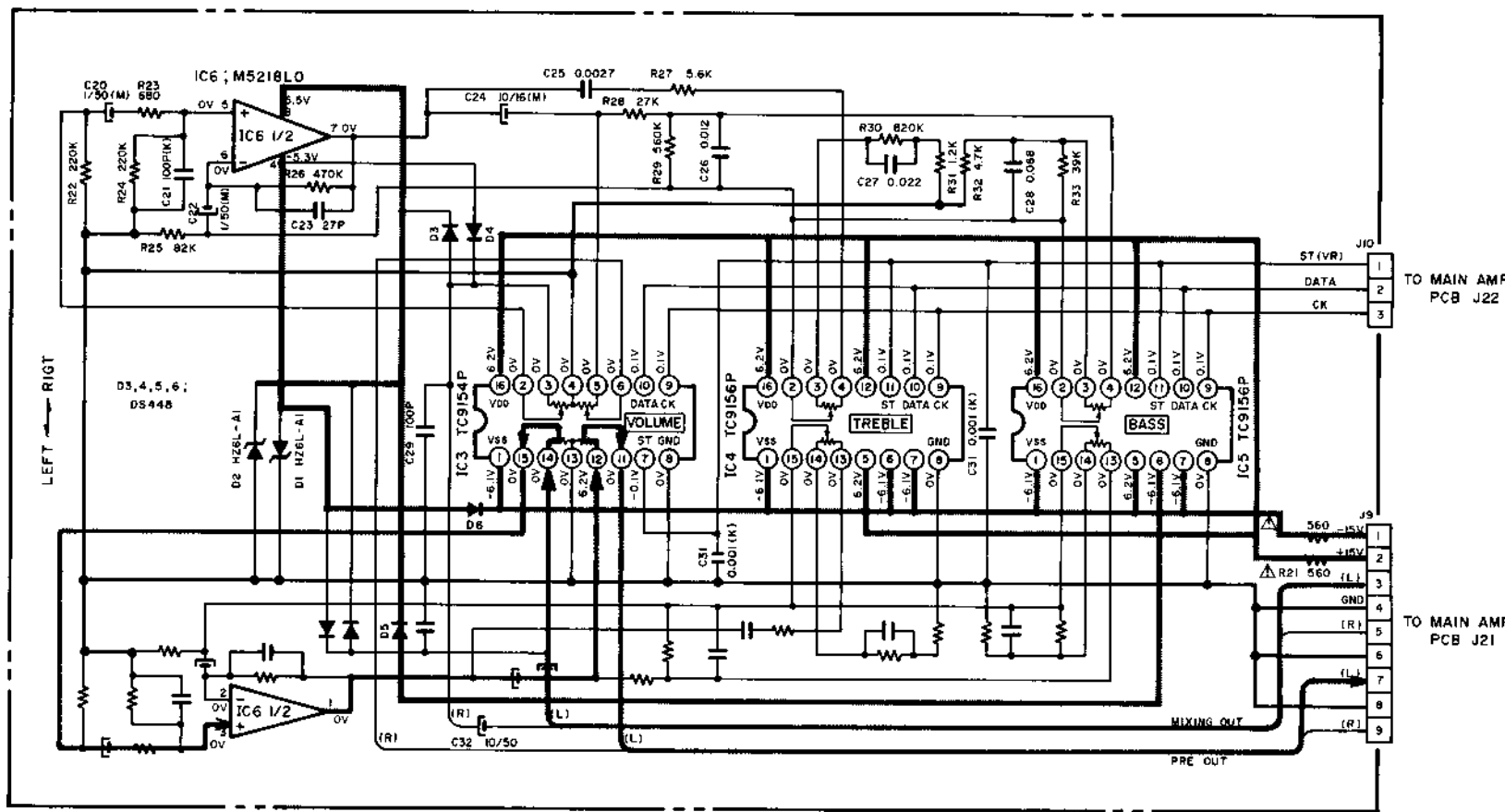
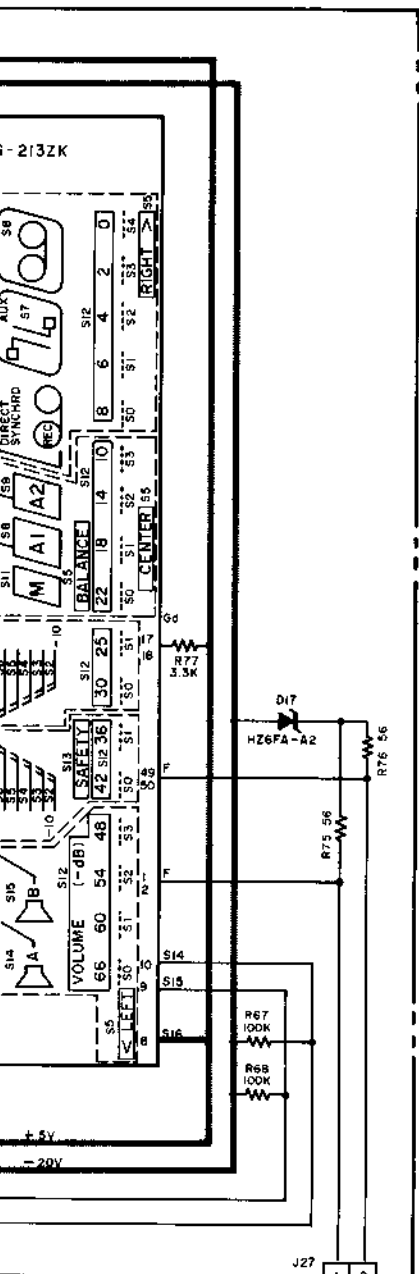
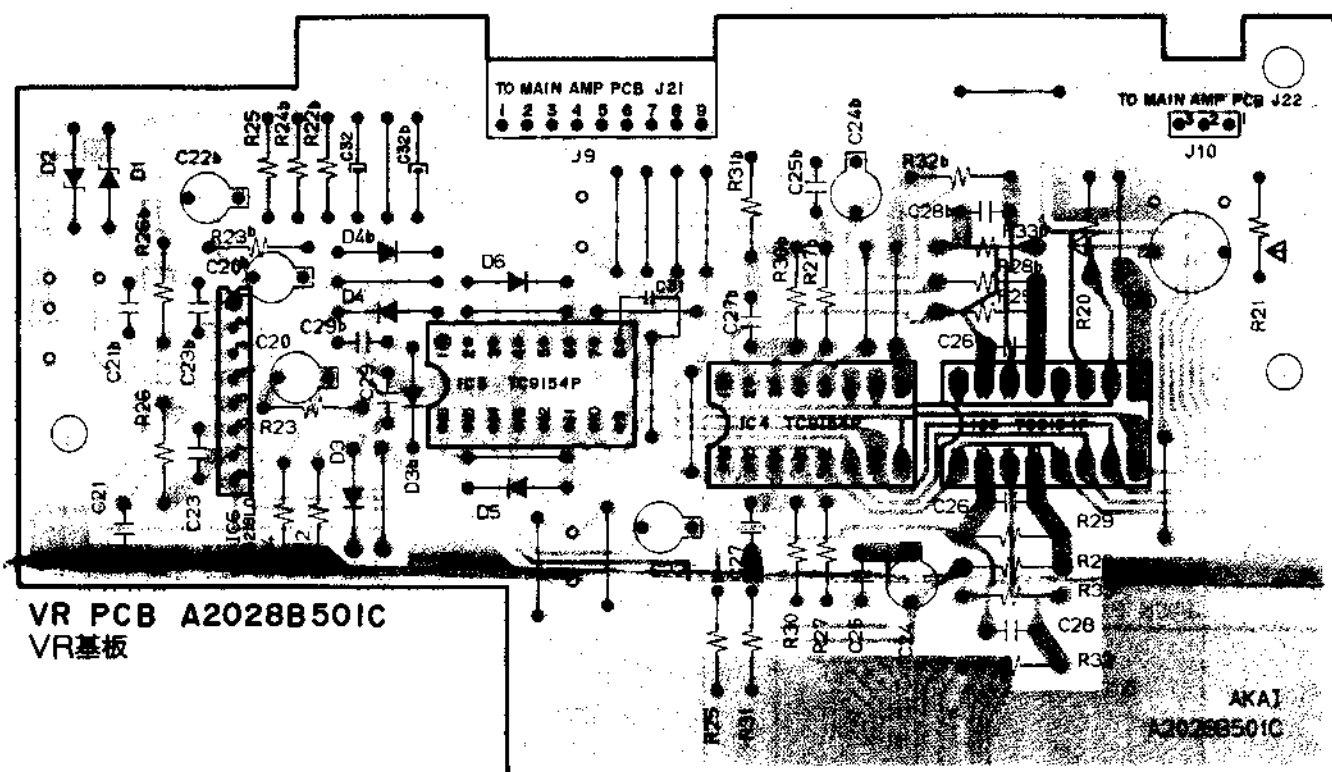
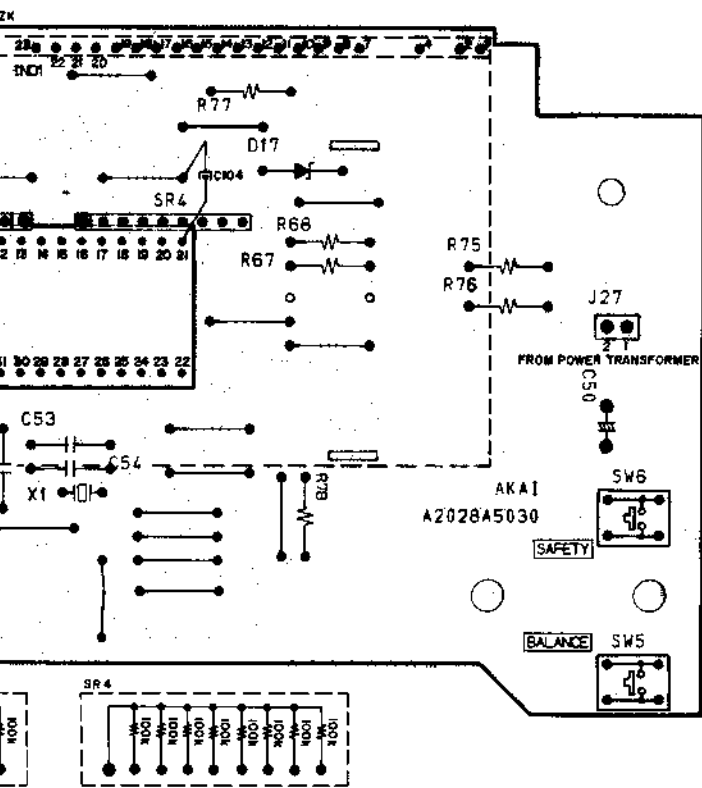

NOTE

UNLESS OTHERWISE SPECIFIED  
ALL RESISTOR IN OHMS 1/4W(J)  
ALL CAPACITORS IN  $\mu$ F 50WV(J)

VOLTAGES ARE INDICATED AT AUX MODE.  
(VOLUME MIN. AND TONE CONT. FLAT)  
SIGNAL LINE IS INDICATED LEFT  
CHANNEL ONLY AT PHONE MODE

— B (POWER SUPPLY) LINE : B電源

— SIGNAL LINE

備考  
C, Rの単位(特に指定された部品以外)  
抵抗…………… $\Omega$  1/4W(J)  
コンデンサ…………… $\mu$ F 50WV(J)  
各電圧は、GND間のDC電圧をデジタルボルツメータにて  
測定した値です

各部の電圧は、AUXモードでボリューム最少、トーン  
コントロールフラット状態での値です。  
信号ラインは、PHONOモードで左チャンネルのみを  
示します。

VR PC BOARD A2028A501C  
VR基板

注意:  $\Delta$ の付された部品は、安全上重要部品です。交換の際は、指定部品以外は使用しないこと。  
WARNING:  $\Delta$  INDICATES SAFETY CRITICAL COMPONENTS.  
FOR CONTINUED SAFETY, REPLACE SAFETY CRITICAL COMPONENTS  
ONLY WITH MANUFACTURER'S RECOMMENDED PARTS.

AVERTISSEMENT:  $\Delta$  IL INDIQUE LES COMPOSANTS CRITIQUES DE SURETE POUR MAINTENIR LE DEGRE DE SECURITE  
DE L'APPAREIL. NE REMPLACEZ LES COMPOSANTS DONI LE FONCTIONNEMENT EST CRITIQUE POUR LA SECURITE  
QUI PAR DES PIECES RECOMMANDEES PAR LE FABRICANT.

AM-M77 FLD/VR  
SCHEMATIC DIAGRAM  
No.2-2 840324A<sub>ac</sub>