

INTEGRATED AMPLIFIER

MODEL **AM-M11**

SECTION 1	SERVICE MANUAL	3
SECTION 2	PARTS LIST	11

SAFETY INSTRUCTIONS

SAFETY CHECK AFTER SERVICING

Confirm the specified insulation resistance between power cord plug prongs and externally exposed parts of the set is greater than 10 Mohms, but for equipment with external antenna terminals (tuner, receiver, etc.) and is intended for **C** or **A**, specified insulation resistance should be more than 2.2 Mohms (ground terminals, microphone jacks, headphone jacks, line-in-out jacks etc.)

PRECAUTIONS DURING SERVICING

- Parts identified by the Δ symbol parts are critical for safety.
Replace only with parts number specified.
- In addition to safety, other parts and assemblies are specified for conformance with such regulations as those applying to spurious radiation. These must also be replaced only with specified replacements.
Examples: RF converters, tuner units, antenna selector switches, RF cables, noise blocking capacitors, noise blocking filters, etc.
- Use specified internal wiring. Note especially:
 - Wires covered with PVC tubing
 - Double insulated wires
 - High voltage leads
- Use specified insulating materials for hazardous live parts. Note especially:
 - Insulation Tape
 - PVC tubing
 - Spacers (Insulating Barriers)
 - Insulation sheets for transistors
 - Plastic screws for fixing microswitch (especially in turntable)
- When replacing AC primary side components (transformers, power cords, noise blocking capacitors, etc.), wrap ends of wires securely about the terminals before soldering.

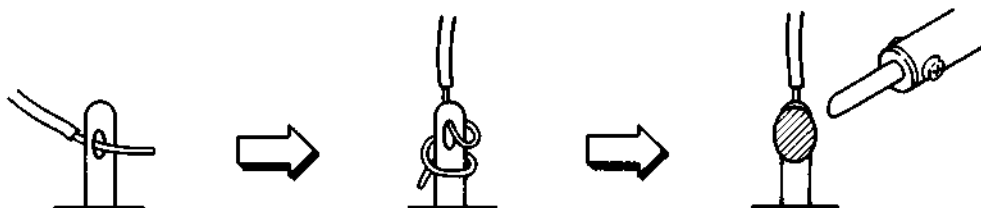

- Observe that wires do not contact heat producing parts (heatsinks, oxide metal film resistors, fusible resistors, etc.).
- Check that replaced wires do not contact sharp edged or pointed parts.
- Also check areas surrounding repaired locations.
- Use care that foreign objects (screws, solder droplets, etc.) do not remain inside the set.

VOLTAGE CONVERSION

Models for USA, Europe, UK and Australia are not equipped with this facility, each machine is preset at the factory according to its destinations, but same machine's voltage can be converted.

Before connecting the AC power cord, turn the VOLTAGE SELECTOR located on the rear panel with a screw-driver until the correct voltage is indicated.

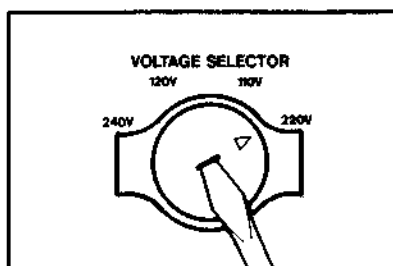

CYCLE CONVERSION

Cycle conversion is not necessary.

SECTION 1

SERVICE MANUAL

TABLE OF CONTENTS

I. SPECIFICATIONS 4
II. DISMANTRING OF UNIT 5
III. CONTROLS 6
IV. PRINCIPAL PARTS LOCATION 7
V. ADJUSTMENT 8
VI. PC BOARD TITLES AND IDENTIFICATION NUMBERS 9

For basic adjustments, measuring methods, and operating principles, refer to GENERAL TECHNICAL MANUAL.

I. SPECIFICATIONS

PRE AMPLIFIER SECTION

INPUT SENSITIVITY/IMPEDANCE	
PHONO	2.5mV/47kohms
CD	150mV/47 kohms
MIC	0.7mV/47kohms
OUTPUT LEVEL/IMPEDANCE	
TAPE REC	150mV/1.5kohms
FREQUENCY RESPONSE	
PHONO (RIAA Deviation)	20Hz to 20kHz, ± 0.5 dB
AUX	5Hz to 80kHz 0dB, -3 dB
TONE CONTROL	
BASS	± 8 dB/100Hz
TREBLE	± 8 dB/10kHz

POWER AMPLIFIER SECTION

RATED OUTPUT POWER			
(2channels driven)	8 ohms	6 ohms	4 ohms
20Hz to 20kHz	30W/0.05%	30W/0.08%	
OUTPUT POWER BY FTC			
(2 channels driven)			
20Hz to 20kHz	32W/0.05%	33W/0.08%	33W/0.08%
1kHz	33W/0.05%	35W/0.05%	35W/0.05%
FRENCH NORMAL			
63Hz to 12.5kHz	36W/0.7%		
1kHz	38W/0.7%		
MUSIC POWER (Both Channel)	170W		
POWER BANDWIDTH (IHF -3 dB, 8ohms)	5Hz to 40kHz (0.1%)		
S/N (IHF-A)			
PHONO	70dB		
CD	80dB		
TAPE	92dB		
MIC	63dB		
RESIDUAL NOISE (8ohms)	0.5mV		
CHANNEL SEPARATION (IHF, 1kHz)	43dB		
DAMPING FACTOR (1kHz, 8ohms)	30		
REQUIRED SPEAKER IMPEDANCE	4 to 16 ohms		
POWER REQUIREMENTS	120V, 60Hz for USA & Canada		
	220V, 50Hz for Europe except UK		
	240V, 50Hz for UK & Australia		
	110V/120V/220V/240V, 50/60Hz switchable for other countries		
POWER CONSUMPTION	150W (A, C Models)		
	140W (U Model)		
DIMENSIONS	350 (W) x104 (H) x255 (D) mm		
	(13.8 x 4.1 x 10 inches)		
WEIGHT	5.0kg (11.0 lbs)		

* For improvement purposes, specifications and design are subject to change without notice.

II. DISMANTRING OF UNIT

In case of trouble, etc. necessitating dismantling, please dismantle in the order shown in the photographs. Reassemble in reverse order.

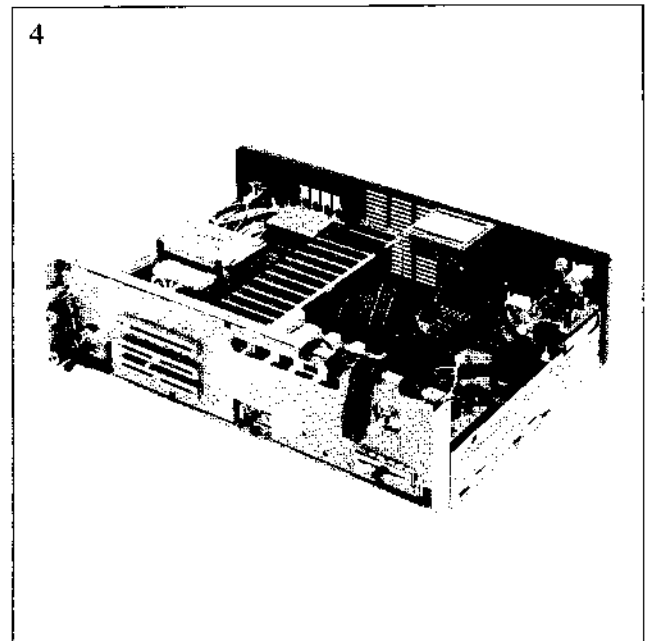
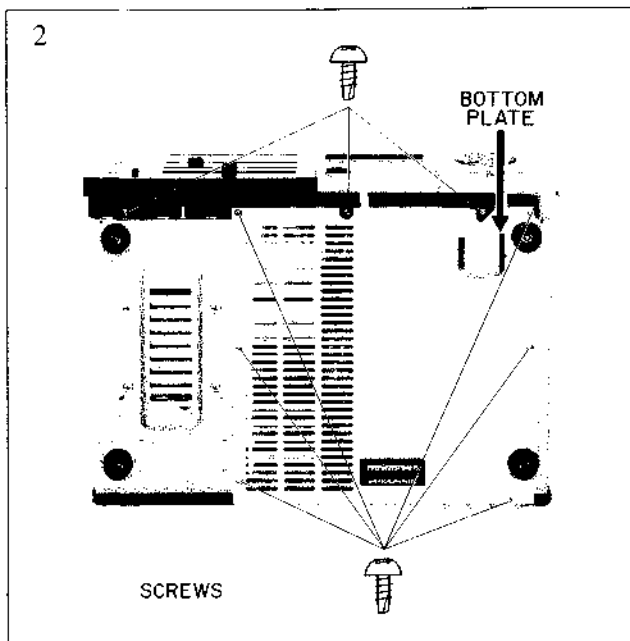
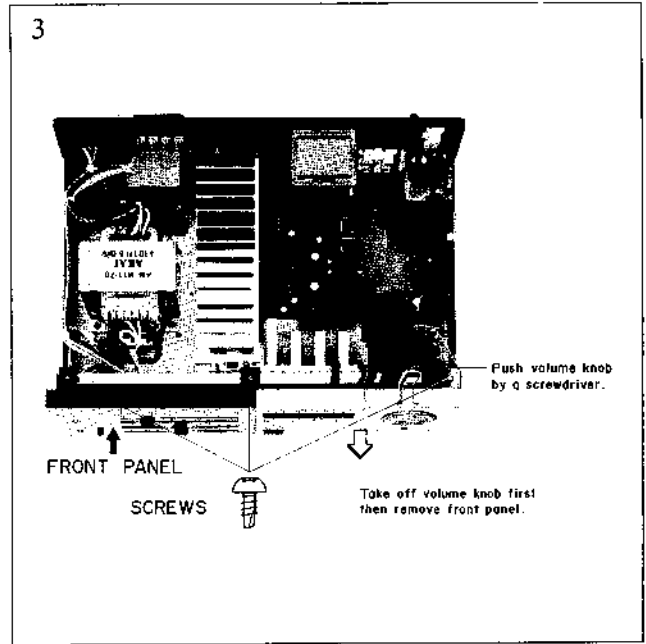
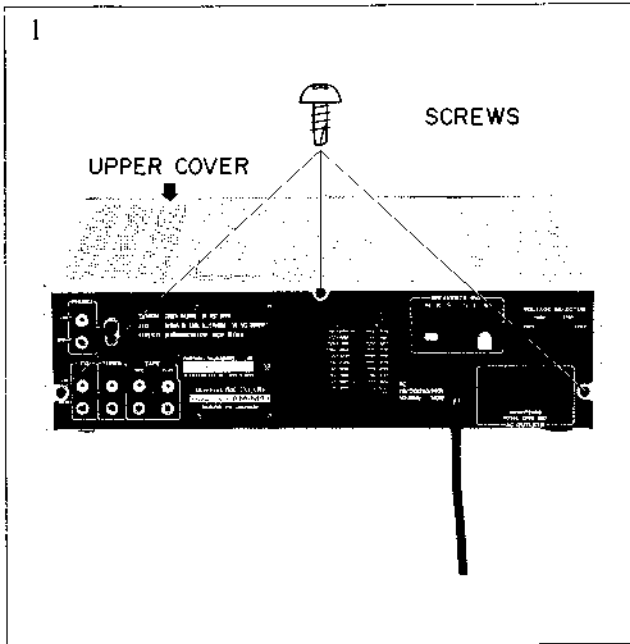

III. CONTROLS

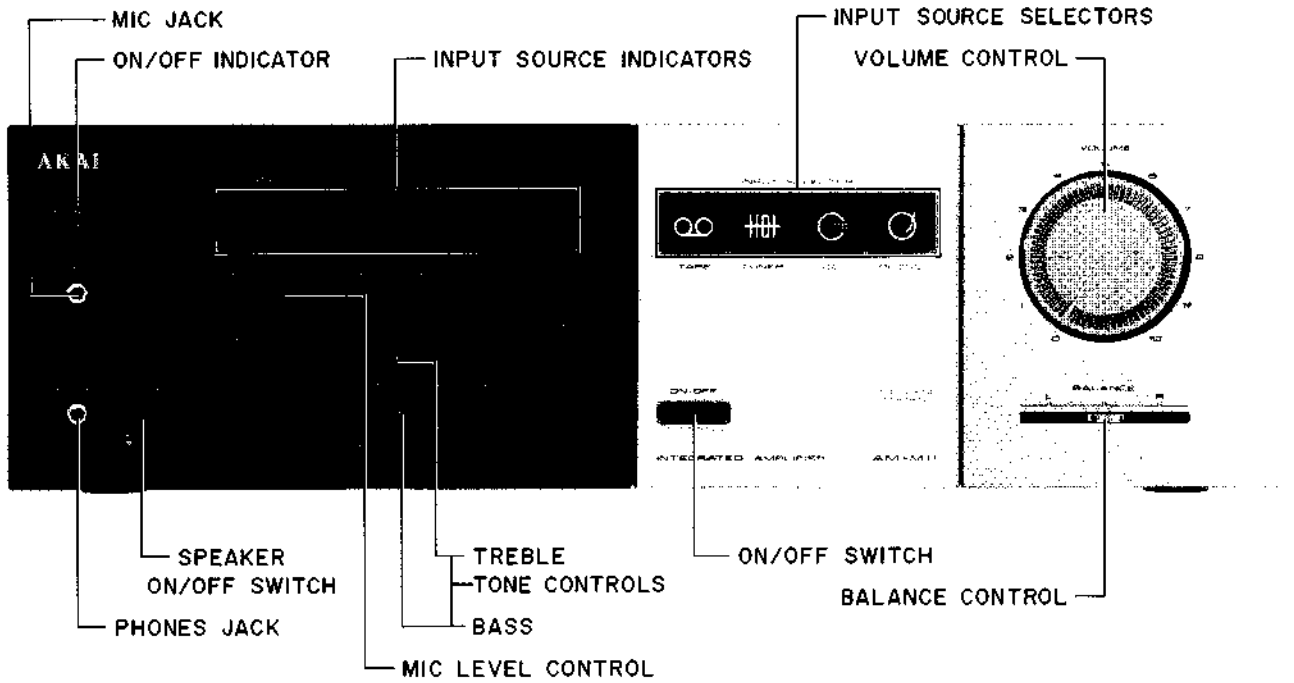

Fig. 3-1 Front View

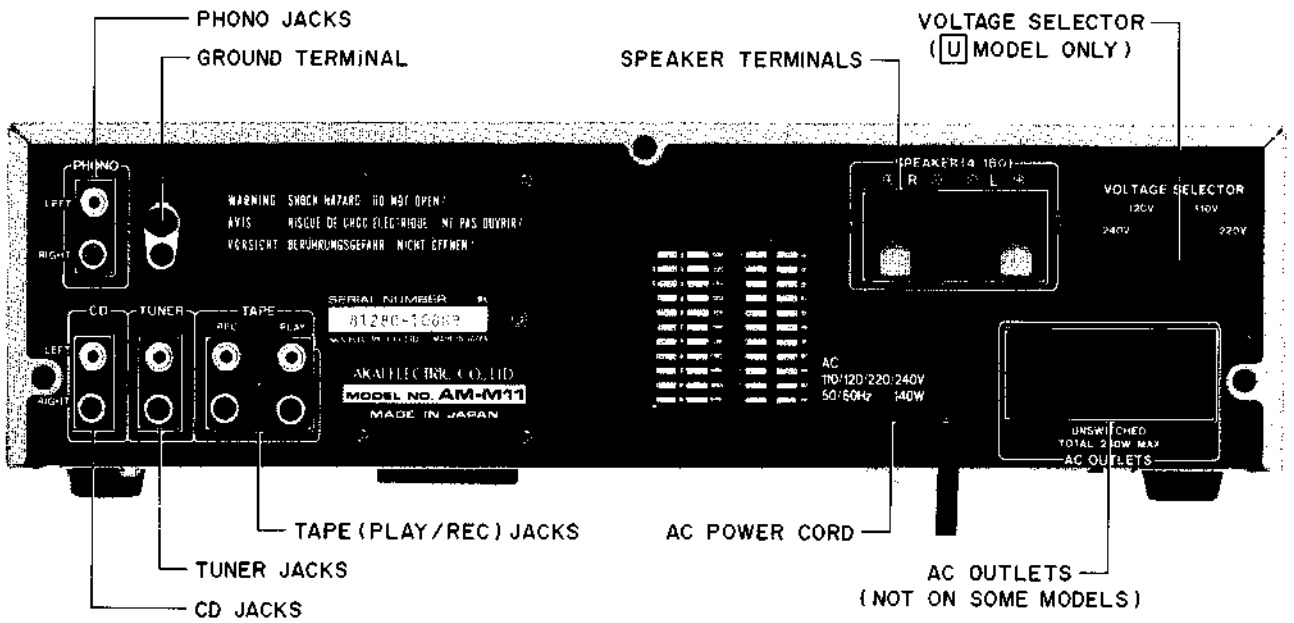

Fig. 3-2 Rear View

IV. PRINCIPAL PARTS LOCATION

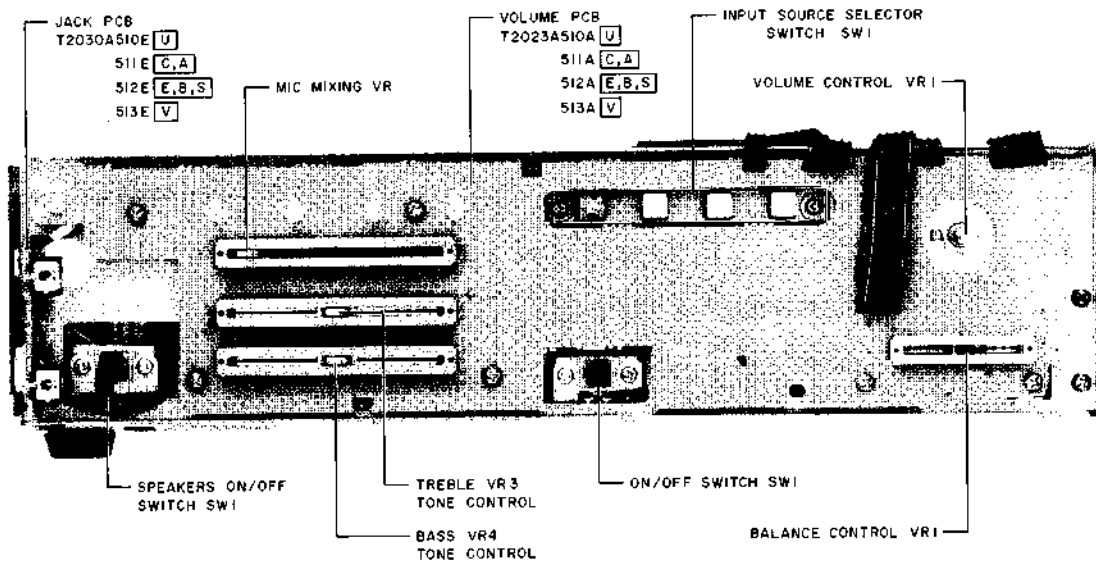

Fig. 4-1 Front View

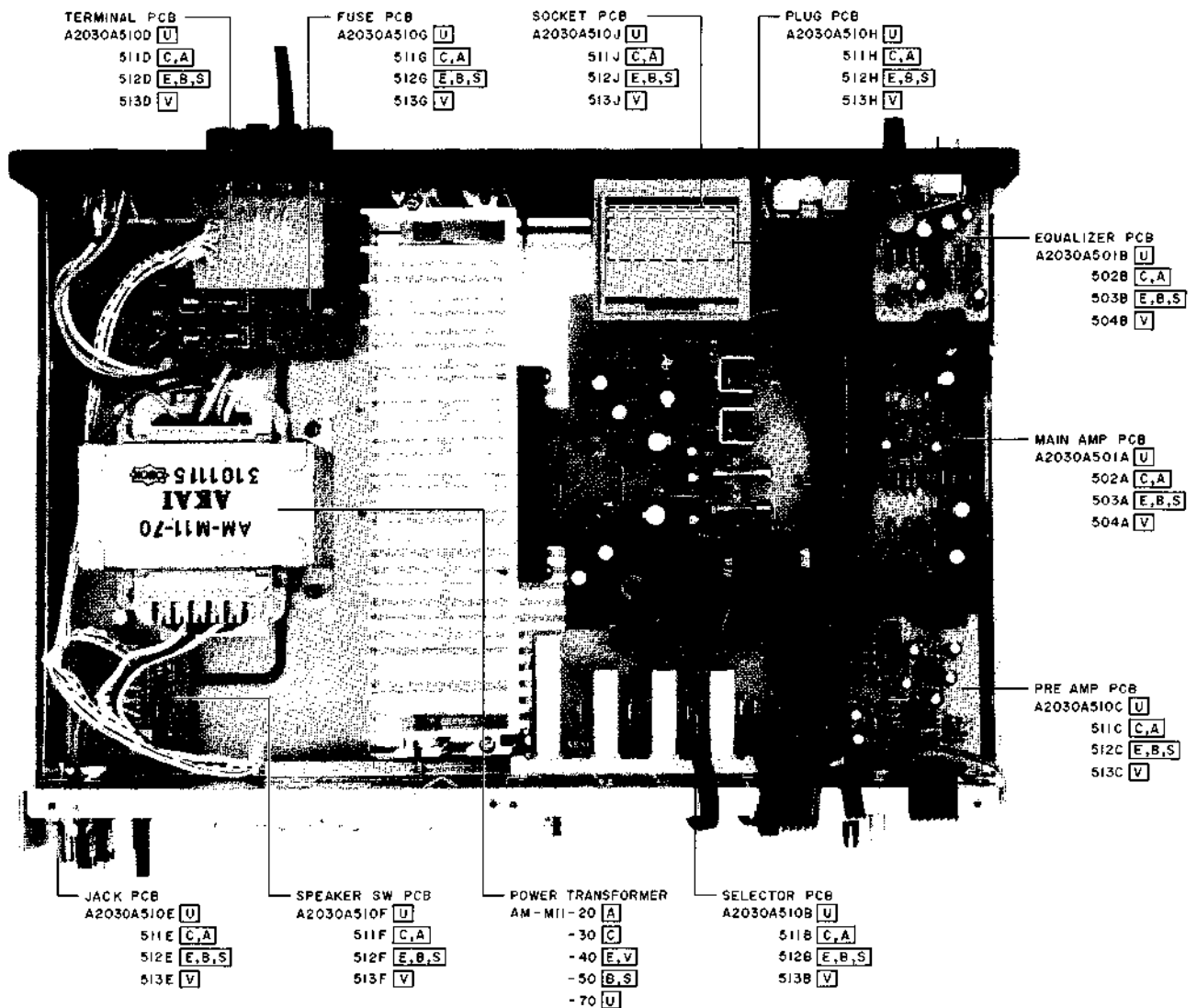

Fig. 4-2 Top View

V. ADJUSTMENT

No Adjustment is Necessary.

VI. PC BOARD TITLES AND IDENTIFICATION NUMBERS

PC BOARD TITLES	IDENTIFICATION NUMBER	REMARKS
MAIN PC BOARD	A2030A 501A	U
	502A	C, A
	503A	E, B, S
	504A	V
EQUALIZE PC BOARD	A2030A 501B	U
	502B	C, A
	503B	E, B, S
	504B	V
VOLUME PC BOARD	A2030A 510A	U
	511A	C, A
	512A	E, B, S
	513A	V
SELECTOR PC BOARD	A2030A 510B	U
	511B	C, A
	512B	E, B, S
	513B	V
PRE-AMP PC BOARD	A2030A 510C	U
	511C	C, A
	512C	E, B, S
	513C	V
TERMINAL PC BOARD	A2030A 510D	U
	511D	C, A
	512D	E, B, S
	513D	V
JACK PC BOARD	A2023A 510E	U
	511E	C, A
	512E	E, B, S
	513E	V
SPEAKER SW PC BOARD	A2023A 510F	U
	511F	C, A
	512F	E, B, S
	513F	V
FUSE PC BOARD	A2023A 510G	U
	511G	C, A
	512G	E, B, S
	513G	V
SOCKET PC BOARD	A2023A 510H	U
	511H	C, A
	512H	E, B, S
	513H	V
PLUG PC BOARD	A2023A 510J	
	511J	
	512J	
	513J	

— MEMO —

— MEMO —

SECTION 2

PARTS LIST

TABLE OF CONTENTS

RECOMMENDED SPARE PARTS	13
1. MAIN PC BOARD BLOCK	14
2. PRE SELECTOR PC BOARD BLOCK	14
3. ASSEMBLY BLOCK	15
4. FINAL ASSEMBLY BLOCK	16
INDEX	16

Resistor and Capacitor which is not listed in this parts list, please refer to
COMMON LIST FOR SERVICE PARTS.

ATTENTION

1. When placing an order for parts, be sure to list the parts no., model no., and description. There are instances in which if any of this information is omitted, parts cannot be shipped or the wrong parts will be delivered.
2. Please be careful not to make a mistake in the parts no. If the parts no. is in error, a part different from the one ordered may be delivered.
3. Because parts number and parts unit supply in the Preliminary Parts List may be partially changed, please use this parts list for all future reference.

HOW TO USE THIS PARTS LIST

1. This Parts List shows the parts that are considered necessary for repairs. Other parts, such as resistors and capacitors, are shown in the "Common List for Service Parts". Select and order such parts from the "Common List for Service Parts".
2. The Recommended Spare Parts shows those parts in the Parts List which are considered particularly important for service.
3. Parts not shown in the Parts List and "Common List for Service Parts" will not be supplied in principle.
4. How to read list
 - a) Mechanism Block
 - b) P.C Board Block

2. HEAD BASE BLOCK

REF. NO.	PARTS NO.	DESCRIPTION
2-1x	BH-T2023A320A	HEAD BASE BLOCK GX-F66R
2-2	HP-H2206A010A	HEAD R/P PR4-8FU C
2-3	ZS-477876	PAN20x03STL CMT
2-4	ZS-536488	BID20x08STL CMT
2-5	ZG-402895	CS ANGLE ADJUST SPRING

SP (Service Parts) Classification

A small "x" indicates the inability to show that particular part in the Photo or Illustration.

This number corresponds with the individual parts index number in that figure

This number corresponds with the Figure Number

6. SYS. CON. P.C BOARD BLOCK

REF. NO.	PARTS NO.	DESCRIPTION
6-1	BA-T2034A070A	PC SYS CON BLK GX-F44R
6-1C1	EI-324536	IC HD14049BP
6-1C2	EI-336801	IC MB8841-564M
6-1C3	EI-331661	IC SN7405N
6-1C4	EI-336725	IC M54527P
6-TR1to4	ET-200985	TR 2SC2603 F,G
6-TR5to28	ET-554657	TR 2SA733A P,Q
6-D1	ED-318292	D SILICON H 1S2473T-77 T26
6-D2to4	ED-308952	D GERMA V 1K34A-LR F07
6-D5to10	ED-318292	D SILICON H 1S2473T-77 T26
6-X1	EI-318384	OSC X'TAL NC-18C 3.579545MHZ

SP (Service Parts) Classification

This reference numbers corresponds with symbol numbers of Schematic Diagrams.

5. Both the kind of part and installation position can be determined by the Parts Number. To determine where a parts number is listed, utilize Parts Index at end of Parts List. It is necessary first of all to find the Parts Number. This can be accomplished by using the Reference Number listed at right of parts number in the Parts Index.

WARNING

Δ INDICATES SAFETY CRITICAL COMPONENTS FOR CONTINUED SAFETY, REPLACE SAFETY CRITICAL COMPONENTS ONLY WITH MANUFACTURE'S RECOMMENDED PARTS

AVERTISSEMENT

Δ IL INDIQUE LES COMPOSANTS CRITIQUES DE SÉCURITÉ. POUR MAINTENIR LE DEGRÉ DE SÉCURITÉ DE L'APPAREIL, NE REMPLACER QUE DES PIÈCES RECOMMANDÉES PAR LE FABRICANT

RECOMMENDED SPARE PARTS

Because, if the parts listed below are on hand, almost any repair can be accomplished, we suggest that you stock these Recommended Spare Parts Items.

REF. NO.	PARTS NO.	DESCRIPTION
1	BT-351828	△ TRANS POWER AM-M11-20(A) (T901)
2	BT-351829	△ TRANS POWER AM-M11-30(C) (T901)
3	BT-351830	△ TRANS POWER AM-M11-40(E,V) (T901)
4	BT-351831	△ TRANS POWER AM-M11-50(B,S) (T901)
5	BT-351833	△ TRANS POWER AM-M11-70(U) (T901)
6	ED-349656	D LED AY5505S
7	ED-349617	D LED SLP-475B-50 YLW
8	ED-200213	D SILICON DBA40C-K15 200/2.6A
9	ED-300924	D SILICON GP08D 200/0.8A
10	ED-348990	D SILICON H DS446
11 N	ED-346569	D ZENER H HZ18L 1
12	EF-623103	△ FUSE SEMKO T 250V 1.00A (E,V,B,S)
13	EF-601301	△ FUSE SEMKO T 250V 2.00A (E,V,B,S)
14	EF-311839	△ FUSE TSC A 250V 1.60A (U)
15	EF-306951	△ FUSE TSC A 250V 2.50A (U)
16	EF-306956	△ FUSE TSC 125V 2.50A (C,A)
17	EF-323080	△ FUSE TSC 125V 3.15A (C,A)
18	EI-346122	△ IC STK4833
19	EI-346071	IC M5218L-21
20	EI-337228	IC M5218L0
21	ER-318248	△ R FUSE ERD2FC S10 1/4W 47R0G
22 N	ER-328520	△ R FUSE ERD2FC 1/4W 1000G
23	ES-349070	△ SW SELECT YKS11-0002 02-4 (SW901) (U)
24	ES-349651	SW PUSH SUL121S14 2-02-02N
25	ES-349659	SW PUSH SUL441A-P 4 THROW
26 N	ET-341400	TR FET 2SK170 BL, GR
27	ET-322598	TR 2SB632K E,F
28	ET-351872	TR 2SC3383 R, S
29	ET-310148	TR 2SD612K E,F
30	EV-349652	VR ROTARY 16P20x3K 3B104
31	EV-349655	VR SLIDE 30P2SV0E MN104
32	EV-349653	VR SLIDE 60P1SV0B B503
33	EV-349654	VR SLIDE 60P2SV0J 15C104

"NOTE" N: New Parts

SYMBOL FOR DESTINATION

- A : AAL (U.S.A.)
- B : UK (England)
- C : CSA (Canada)
- E : CEE (Europe)
- S : SAA (Australia)
- U : U/T (Universal Area)
- V : VDE (West Germany)

1. MAIN P C BOARD BLOCK

REF. NO.	PARTS NO.	DESCRIPTION
1-1U	BA-A2030A020A	PC MAIN BLK AM-M11(U) (U)
1-1C	BA-A2030A020B	PC MAIN BLK AM-M11(C) (C,A)
1-1E	BA-A2030A020C	PC MAIN BLK AM-M11(E) (E,B,S)
1-1V	BA-A2030A020D	PC MAIN BLK AM-M11(V) (V)
MAIN PC BOARD		
1-JC1	EI-346071	IC M5218L-21
1-TR1	ET-310148	△ TR 2SD612K E,F
1-TR2	ET-322598	△ TR 2SB632K E,F
1-TR3	ET-341400	TR FET 2SK170 BL,GR
1-D1	ED-200213	△ D SILICON DBA40C-K15 200/2.6A
1-D2	ED-300924	△ D SILICON GP08D 200/0.8A
1-D3	ED-300924	△ D SILICON GP08D 200/0.8A
1-D4	ED-348990	D SILICON H DS446
1-D5	ED-346569	△ D ZENER H HZ18L 1
1-D6	ED-346569	△ D ZENER H HZ18L 1
1-D7	ED-348990	D SILICON H DS446
1-L1	EO-337880	COIL FIX 2 202AK-018 2R2K
1-L2 to 5	EO-336934	COIL FIX 1 LAL03KH 2R2M (U,V)
1-R1,R2	ER-302241	△ R CB H S10 FS RDS 1/4W 4R7J
1-R5	ER-313517	△ R OMF H SNP FS 2W 222J
1-R6	ER-333109	△ R OMF H S20 FS 2W 472J
1-R9,10	ER-302241	△ R CB H S10 FS RDS 1/4W 4R7J
1-R14,15	ER-318248	△ R FUSE ERD2FC S10 1/4W 47ROG
1-R38	ER-200940	△ R CB H S10 FS RDS 1/4W 561J
1-R39	ER-328520	△ R FUSE ERD2FC 1/4W 1000G
1-R40	ER-311685	△ R CB H S15 FS RDS 1/2W 4R7J
1-C1,2	EC-349660	C EC V 682M 45DC
1-C27	EC-333974	C EC V CUT NP SM 220M 50DC
1-J2,3	EJ-336905	PIN J AJC-035-ACB P 4P
EQUALIZER PC BOARD		
1-JC1B	EI-337228	IC M5218L0
1-L1B	EO-338420	COIL FIX 2 FL12R202E 202K (V)
1-J1B	EJ-337424	PIN J AJC-034-AAB P 2P

2. PRE SELECTOR P C BOARD BLOCK

REF. NO.	PARTS NO.	DESCRIPTION
2-1U	BA-A2030A060A	PC PRE SELECTER BLK AM-M11 (U) (U)
2-1C	BA-A2030A060B	PC PRE SELECTER BLK AM-M11 (C) (C,A)
2-1E	BA-A2030A060C	PC PRE SELECTER BLK AM-M11 (E) (E,B,S)
2-1V	BA-A2030A060D	PC PRE SELECTER BLK AM-M11 (V) (V)
VOLUME PC BOARD		
2-D1	ED-349617	D LED SLP-475B-50 YLW
2-D2 to 5	ED-349656	D LED AY5505S
2-VR1	EV-349653	VR SLIDE 60P1SV0B B503
2-VR2	EV-349655	VR SLIDE 30P2SV0E MN104
2-VR3,4	EV-349654	VR SLIDE 60P2SV0J 15C104
SELECTOR PC BOARD		
2-SW1B	ES-349659	SW PUSH SUL441A-P 4 THROW
PRE AMP PC BOARD		
2-IC1C	EI-337228	IC M5218L0
2-TR1C	ET-351872	TR 2SC3383 R,S
to 3C	ET-351872	TR 2SC3383 R,S
2-VR1C	EV-349652	VR ROTARY 16P20x3K 3B104
TERMINAL PC BOARD		
2-TM1D	EJ-349417	TERMINAL LEVER YKD21-0026 4P
2-L1D	EO-342936	COIL BALUN (V)
JACK PC BOARD		
2-J1E	EJ-349657	PHONE J HSJ0922-050 3.5 C
2-J2E	EJ-349658	PHONE J 2P HSJ0922-040 3.5 T
2-L1E	EO-338420	COIL FIX 2 FL12R202E 202K (V)
2-L2E	EO-336934	COIL FIX 1 LAL03KH 2R2M (V)
SPEAKER SWITCH PC BOARD		
2-SW1F	ES-349651	SW PUSH SUL121S14 2-02-02N
2-R1F	ER-341331	△ R OMF H SNP FS 1W 181J
FUSE P.C BOARD		
2-L1G	EO-338409	COIL LF FK0B160MH02 250UH (V)

ASSEMBLY BLOCK

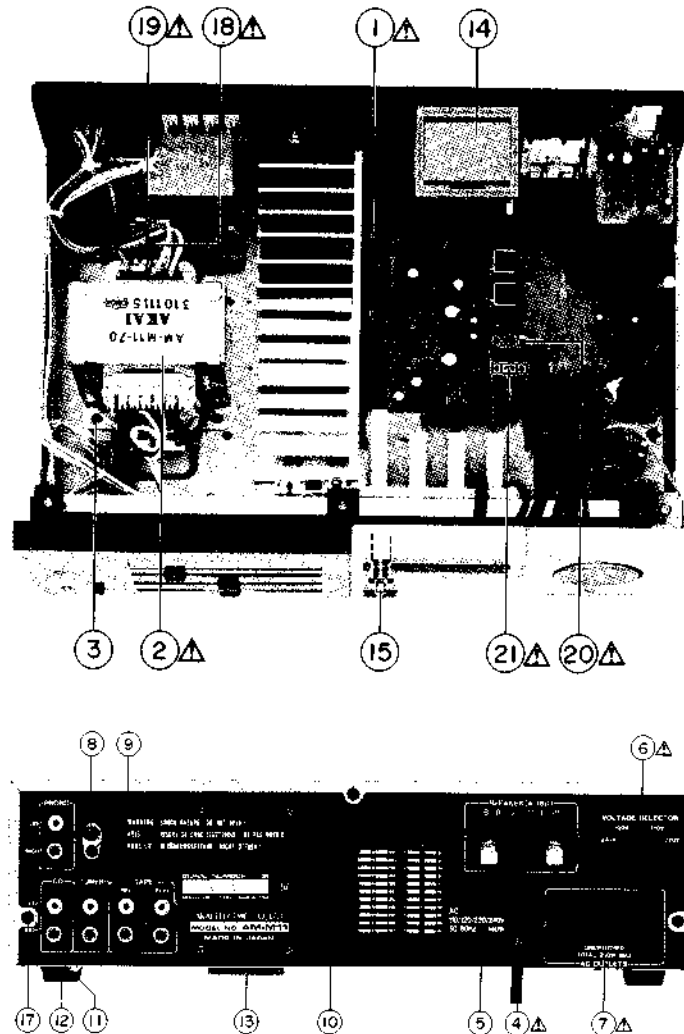

3. ASSEMBLY BLOCK

REF. NO.	PARTS NO.	DESCRIPTION	REF. NO.	PARTS NO.	DESCRIPTION
3-1	EJ-346122	△ IC STK4833	3-8	EJ-329610	TERMINAL W/SCREW UB-0067 L 1P (TM901)
3-2U	BT-351833	△ TRANS POWER AM-M11-70(U)	3-9	ZS-351886	PT BR 30×10STL BNI
3-2C	BT-351829	△ TRANS POWER AM-M11-30(C)	3-10U	SP-350887L	PANEL REAR AM-M11 (U)
3-2A	BT-351828	△ TRANS POWER AM-M11-20(A)	3-10C	SP-350887P	PANEL REAR AM-M11 (C,A)
3-2E	BT-351830	△ TRANS POWER AM-M11-40(E,V)	3-10E	SP-350887M	PANEL REAR AM-M11 (E,V)
3-2B	BT-351831	△ TRANS POWER AM-M11-50(B,S)	3-10B	SP-350887N	PANEL REAR AM-M11 (B,S)
3-3	ZS-301398	ST BID40×08STL CMT	3-11	SA-202118	FOOT
3-4U	EW-374894	△ AC CORD 2 CORES VM-0129A, VFF U/T (U)	3-12	ZS-331891	T2BR30×06STL CMT PW080
3-4C	EW-349427	△ AC CORD 2 CORES KP-8W, SPT-2 UC (C)	3-13	EJ-350918	PLUG CONNECTER M1690 12P
3-4A	EW-349428	△ AC CORD 2 CORES KP-8W, SPT-1 UC (A)	3-14	EJ-351021	SOCKET CONNECTER M1688 12P
3-4E	EW-347897	△ AC CORD 2 CORES VM0364, LCFL EV (E,V)	3-15	ES-349651	SW PUSH SUL121S14 2-02-02N (SW1)
3-4B	EW-347828	△ AC NR BS 42/0.15×2 EV (B)	3-16x	ZW-305013	RV POP32 (A)
3-4S	EW-347898	△ AC CORD 2 CORES VM-0436, LCFL S (S)	3-17	ZS-308846	T2BR30×08STL BZN PROJECTION
3-5	EZ-631945	STRAIN RELIEF SR-4N-4	3-18U	EF-311839	△ FUSE TSC A 250V 1.60A (F1) (U)
3-6	ES-349070	△ SW SELECT YKS11-0002 02-4 (SW901) (U)	3-18C	EF-323080	△ FUSE TSC 125V 3.15A (F1) (C,A)
3-7	EJ-351882	△ SOCKET OUTLET S2T733T122 JUC 3×2P (J901) (U,C,A)	3-18E	EF-623103	△ FUSE SEMKO T 250V 1.00A (F1) (E,V,B,S)
			3-19U	EF-311839	△ FUSE TSC A 250V 1.60A (F2) (U)
			3-20U	EF-306951	△ FUSE TSC A 250V 2.50A (F3) (U)
			3-20C	EF-306956	△ FUSE TSC 125V 2.50A (F3) (C,A)
			3-20E	EF-601301	△ FUSE SEMKO T 250V 2.00A (F3) (E,V,B,S)
			3-21U	EF-306951	△ FUSE TSC A 250V 2.50A (F4) (U)
			3-21C	EF-306956	△ FUSE TSC 125V 2.50A (F4) (C,A)
			3-21E	EF-601301	△ FUSE SEMKO T 250V 2.00A (F4) (E,V,B,S)

PARTS LIST AM-M11

FINAL ASSEMBLY BLOCK

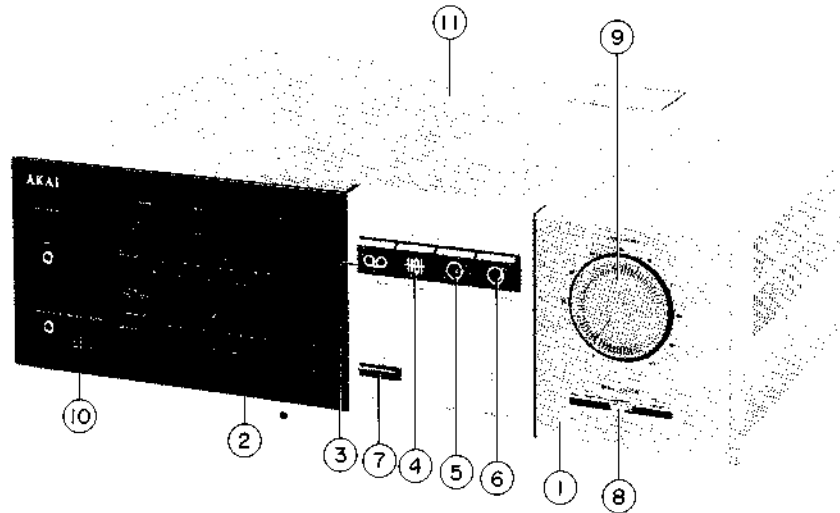

4. FINAL ASSEMBLY BLOCK

REF. NO.	PARTS NO.	DESCRIPTION
4-1	BD-A2030A050A	PANEL FRONT BLK AM-M11
4-2	SK-351215	KNOB SLIDE (A)
4-3	SK-351427H	KNOB PUSH (A) TAPE
4-4	SK-351427F	KNOB PUSH (A) TUNER
4-5	SK-351427G	KNOB PUSH (A) CD
4-6	SK-351427E	KNOB PUSH (A) PHONO
4-7	SK-351428	KNOB POWER
4-8	SK-350881	KNOB SLIDE (B)
4-9	SK-345375F	KNOB VOLUME (D)
4-10	SK-344331A	KNOB PUSH (1)
4-11	SP-350869	COVER UPPER

INDEX

PARTS NO.	REF. NO.	PARTS NO.	REF. NO.	PARTS NO.	REF. NO.	PARTS NO.	REF. NO.	PARTS NO.	REF. NO.
BA-A2030A020A	1-1U	EF-306951	3-21U	EO-338420	1-L1B	EW-347828	3-4B		
BA-A2030A020B	1-1C	EF-306956	3-20C	EO-338420	2-L1E	EW-347897	3-4E		
BA-A2030A020C	1-1E	EF-306956	3-21C	EO-342936	2-L1D	EW-347898	3-4S		
BA-A2030A020D	1-1V	EF-311839	3-18U	ER-200940	1-R38	EW-349427	3-4C		
BA-A2030A060A	2-1U	EF-311839	3-19U	ER-302241	1-R1	EW-349428	3-4A		
BA-A2030A060B	2-1C	EF-323080	3-18C	ER-302241	1-R2	EW-374894	3-4U		
BA-A2030A060C	2-1E	EF-601301	3-20E	ER-302241	1-R9	EZ-631945	3-5		
BA-A2030A060D	2-1V	EF-601301	3-21E	ER-302241	1-R10	SA-202118	3-11		
BD-A2030A050A	4-1	EF-623103	3-18E	ER-311685	1-R40	SK-344331A	4-10		
BT-351828	3-2A	EI-337228	1-IC1B	ER-313517	1-R5	SK-345375F	4-9		
BT-351829	3-2C	EI-337228	2-IC1C	ER-318248	1-R14	SK-350881	4-8		
BT-351830	3-2E	EI-346071	1-IC1	ER-318248	1-R15	SK-351215	4-2		
BT-351831	3-2B	EI-346122	3-1	ER-328520	1-R39	SK-351427E	4-6		
BT-351833	3-2U	EJ-329610	3-8	ER-333109	1-R6	SK-351427F	4-4		
EC-333974	1-C27	EJ-336905	1-J2	ER-341331	2-R1F	SK-351427G	4-5		
EC-349660	1-C1	EJ-336905	1-J3	ES-349070	3-6	SK-351427H	4-3		
EC-349660	1-C2	EJ-337424	1-J1B	ES-349651	2-SW1F	SK-351428	4-7		
ED-200213	1-D1	EJ-349417	2-TM1D	ES-349651	3-15	SP-350869	4-11		
ED-300924	1-D2	EJ-349657	2-J1E	ES-349659	2-SW1B	SP-350887L	3-10U		
ED-300924	1-D3	EJ-349658	2-J2E	ET-310148	1-TR1	SP-350887M	3-10E		
ED-346569	1-D5	EJ-350918	3-13	ET-322598	1-TR2	SP-350887N	3-10B		
ED-346569	1-D6	EJ-351021	3-14	ET-341400	1-TR3	SP-350887P	3-10C		
ED-348990	1-D4	EJ-351882	3-7	ET-351872	2-TR1C	ZS-301398	3-3		
ED-348990	1-D7	EO-336934	1-L2	ET-351872	2-TR2C	ZS-308846	3-17		
ED-349617	2-D1	EO-336934	1-L3	ET-351872	2-TR3C	ZS-331891	3-12		
ED-349656	2-D2	EO-336934	1-L4	EV-349652	2-VR1C	ZS-351886	3-9		
ED-349656	2-D3	EO-336934	1-L5	EV-349653	2-VR1	ZW-305013	3-16x		
ED-349656	2-D4	EO-336934	2-L2E	EV-349654	2-VR3				
ED-349656	2-D5	EO-337880	1-L1	EV-349654	2-VR4				
EF-306951	3-20U	EO-338409	2-L1G	EV-349655	2-VR2				

AKAI

MODEL AM-M11

P.C. BOARD SCHEMATIC DIAGRAM

M5218L0, M5218L-21

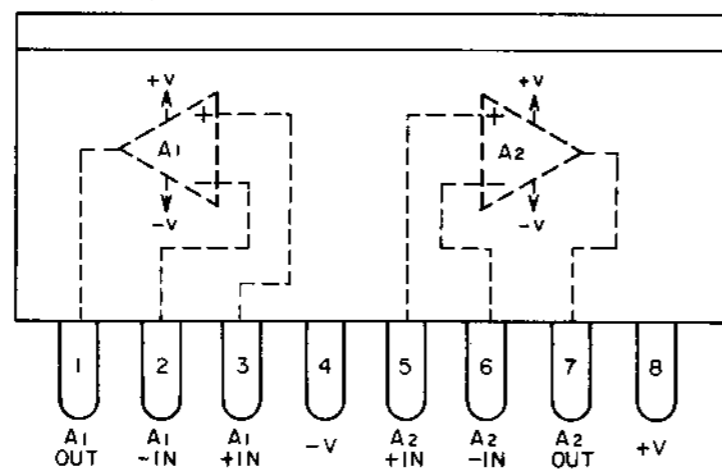

STK4833

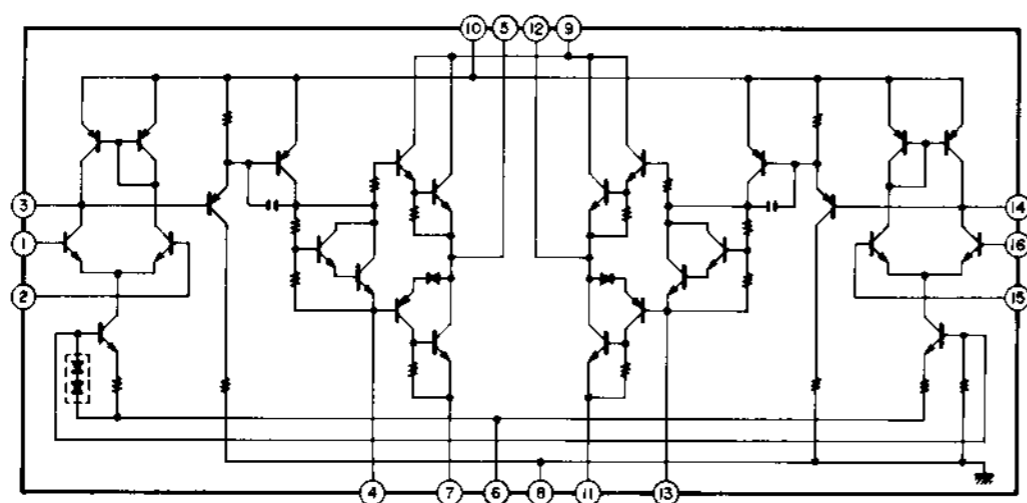

AM - M11

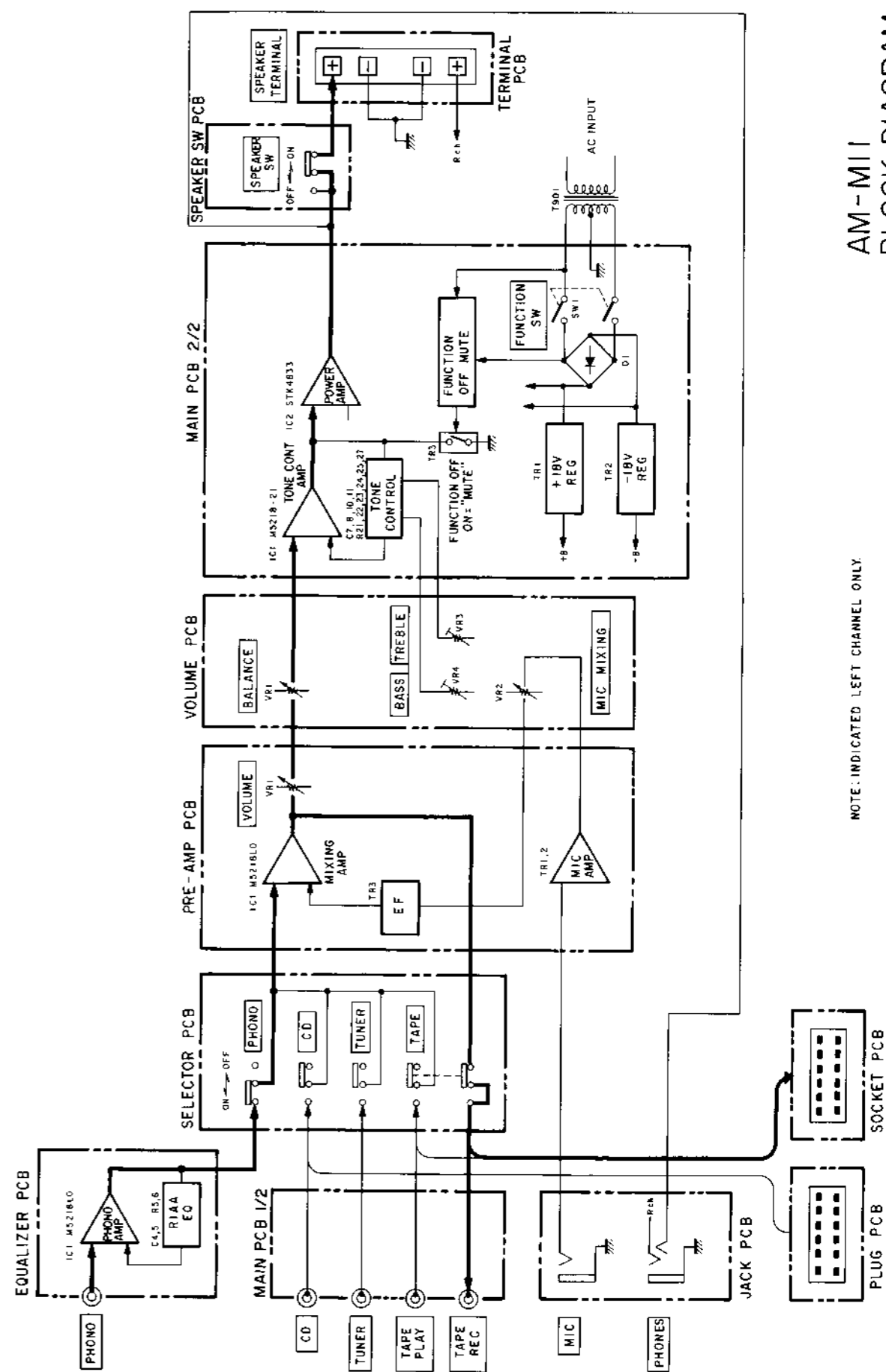

NOTE: INDICATED LEFT CHANNEL ONLY

AM - M11
BLOCK DIAGRAM
No. 840410A^(L3)

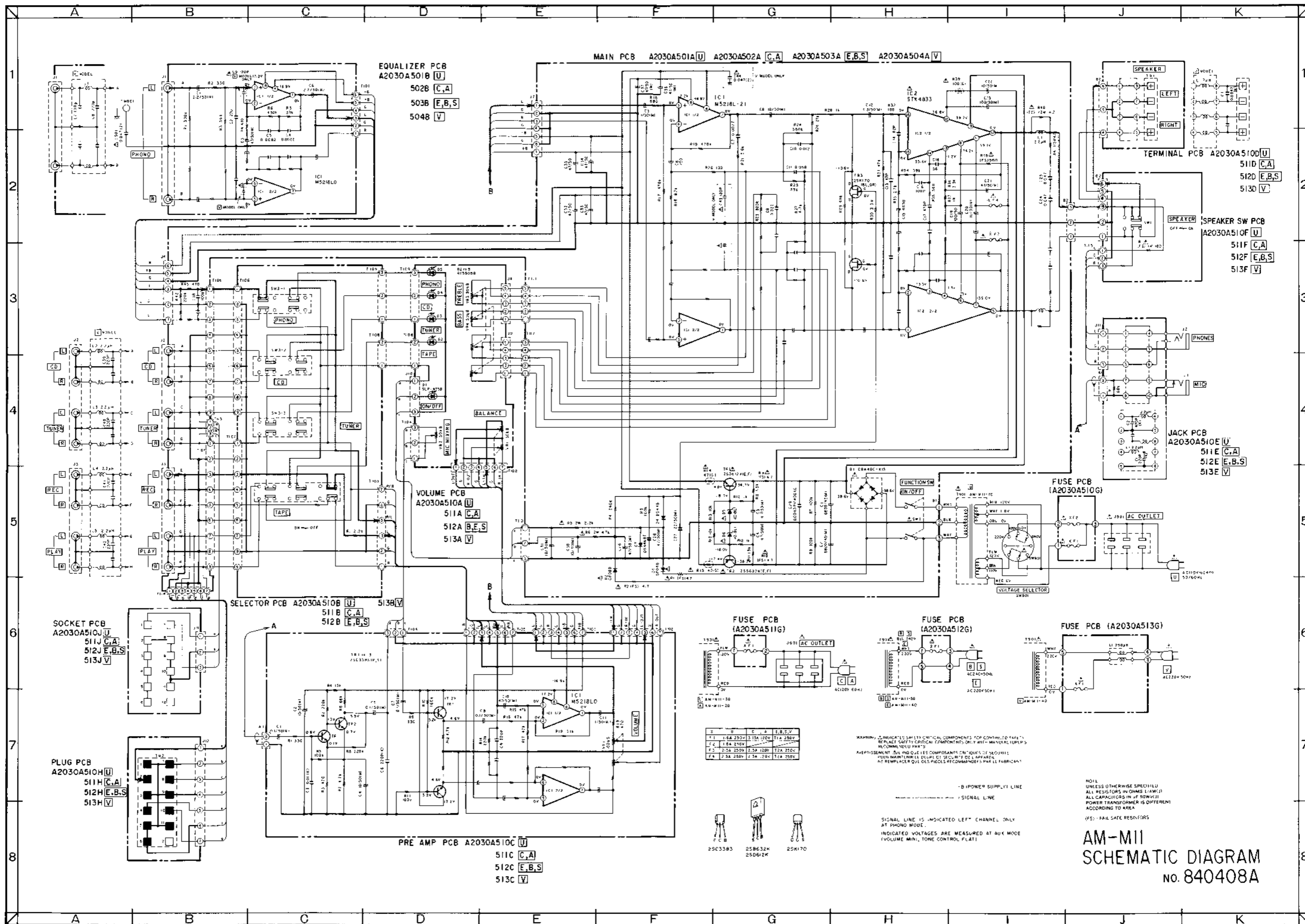

PRE AMP PCB

- A2030A510C U
- A2030A511C C A
- A2030A512C E B S
- A2030A513C V

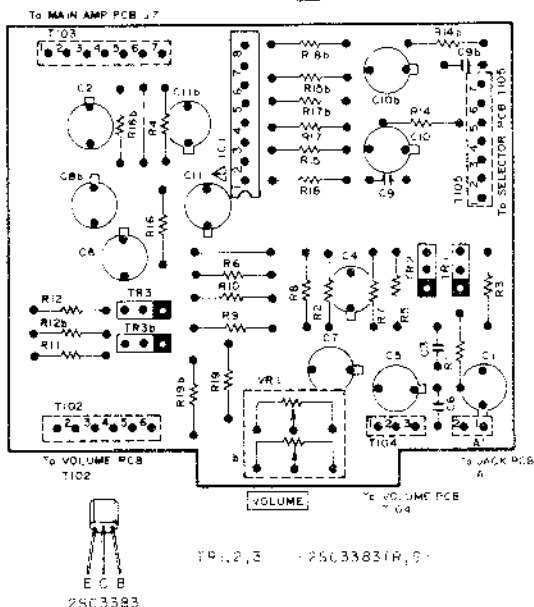

SELECTOR PCB

- A2030A510B U
- A2030A511B C A
- A2030A512B E B S
- A2030A513B V

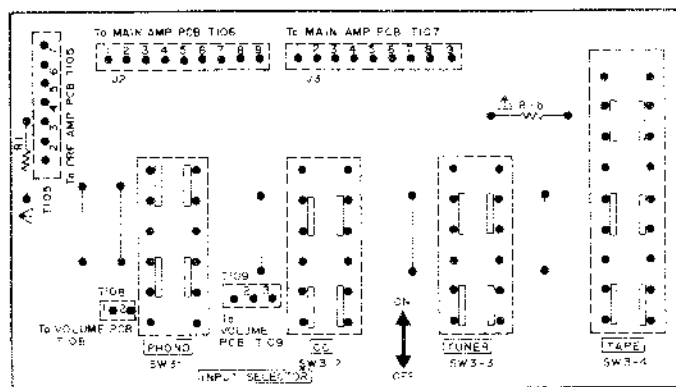

SPEAKER SW PCB

- A2030A510F U
- A2030A511F C A
- A2030A512F E B S
- A2030A513F V

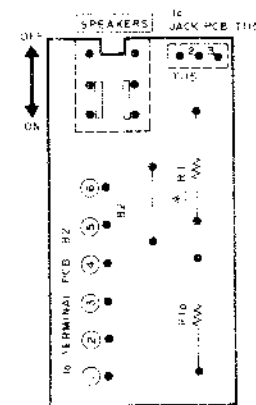

PLUG PCB

- A2030A510H U
- A2030A511H C A
- A2030A512H E B S
- A2030A513H V

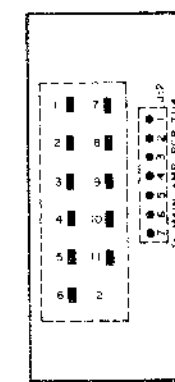

TERMINAL PCB

- A2030A510D U
- A2030A511D C A
- A2030A512D E B S
- A2030A513D V

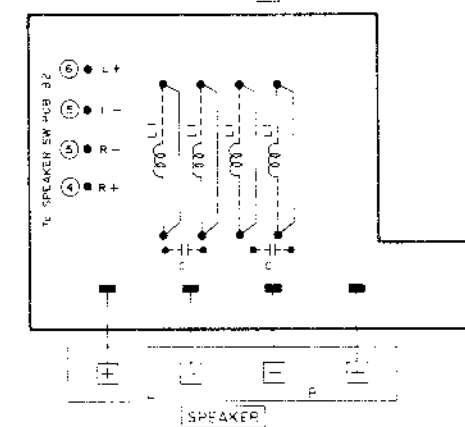

JACK PCB

- A2030A510E U
- A2030A511E C A
- A2030A512E E B S
- A2030A513E V

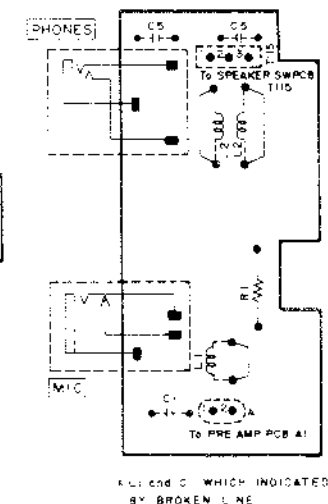

SOCKET PCB

- A2030A510J U
- A2030A511J C A
- A2030A512J E B S
- A2030A513J V

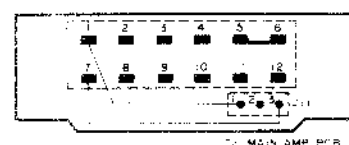

ALL PCB'S WHICH INDICATED BY BROKEN LINE

ALL PCB'S WHICH INDICATED BY BROKEN LINE

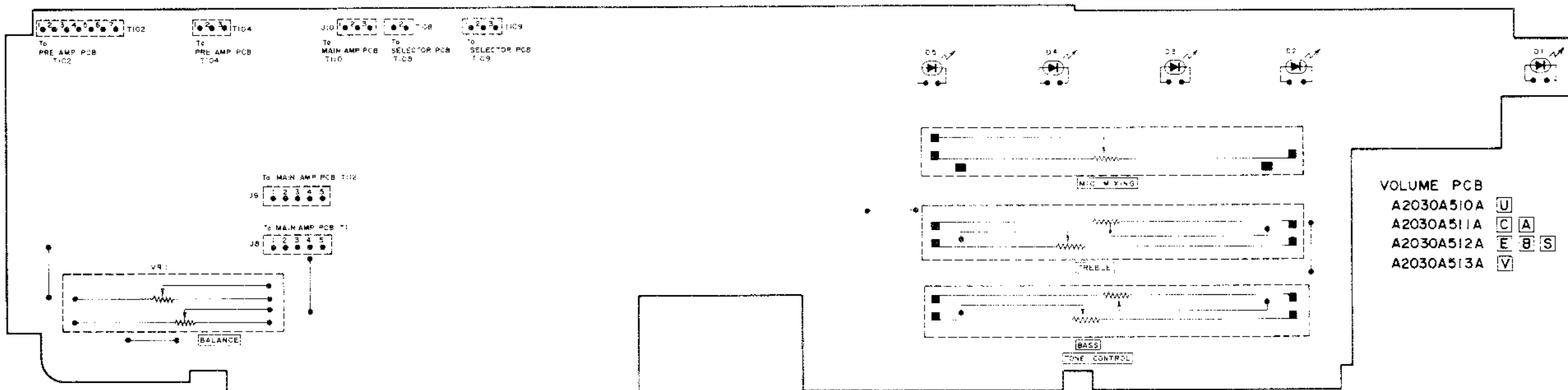

- A2030A510A U
- A2030A511A C A
- A2030A512A E B S
- A2030A513A V

FUSE PCB

- A2030A511G C A

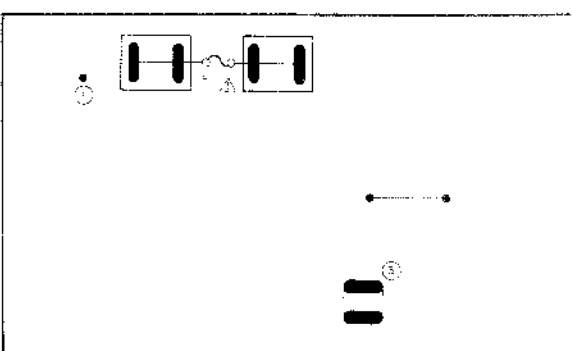

FUSE PCB

- A2030A512G E B S

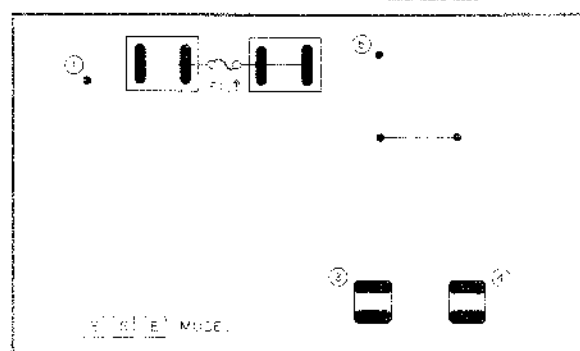

FUSE PCB

- A2030A513G V

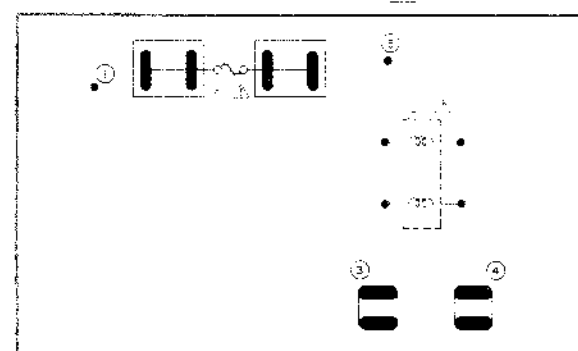

FUSE PCB

- A2030A510G U

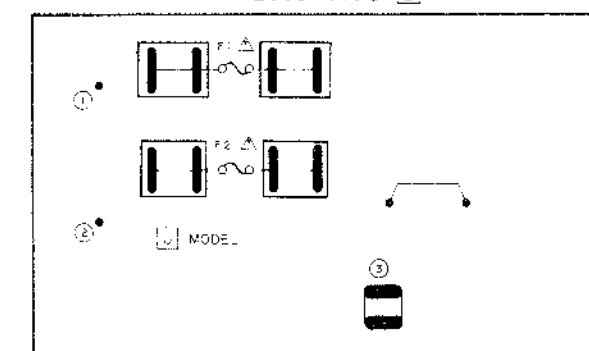

WARNING: INDICATE SAFETY CRITICAL COMPONENTS FOR CONTINUED SAFETY. REPLACE SAFETY CRITICAL COMPONENTS ONLY WITH MANUFACTURER'S RECOMMENDED PARTS.

AVERTISSEMENT: INDIQUEZ LES COMPOSANTS CRITIQUES DE SECURITE POUR MANTENIR LE DEGRE DE SECURITE DE L'APPAREIL. NE REMPLACEZ QUE LES PIECES RECOMMANDEES PAR LE FABRICANT.

MAIN AMP PCB

- A2030A501A [U]
- A2030A502A [C] [A]
- A2030A503A [E] [B] [S]
- A2030A504A [V]

* C2 to C5, and C39 to C42, WHICH INDICATED BY BROKEN LINE ARE [V] MODEL ONLY

(MAIN AMP PCB)

- TR
- TR 1 ----- 2SD612K (E, F)
 - TR 2 ----- 2SB632K (E, F)
 - TR 3 (FET) ----- 2SK170 (BL, GR)

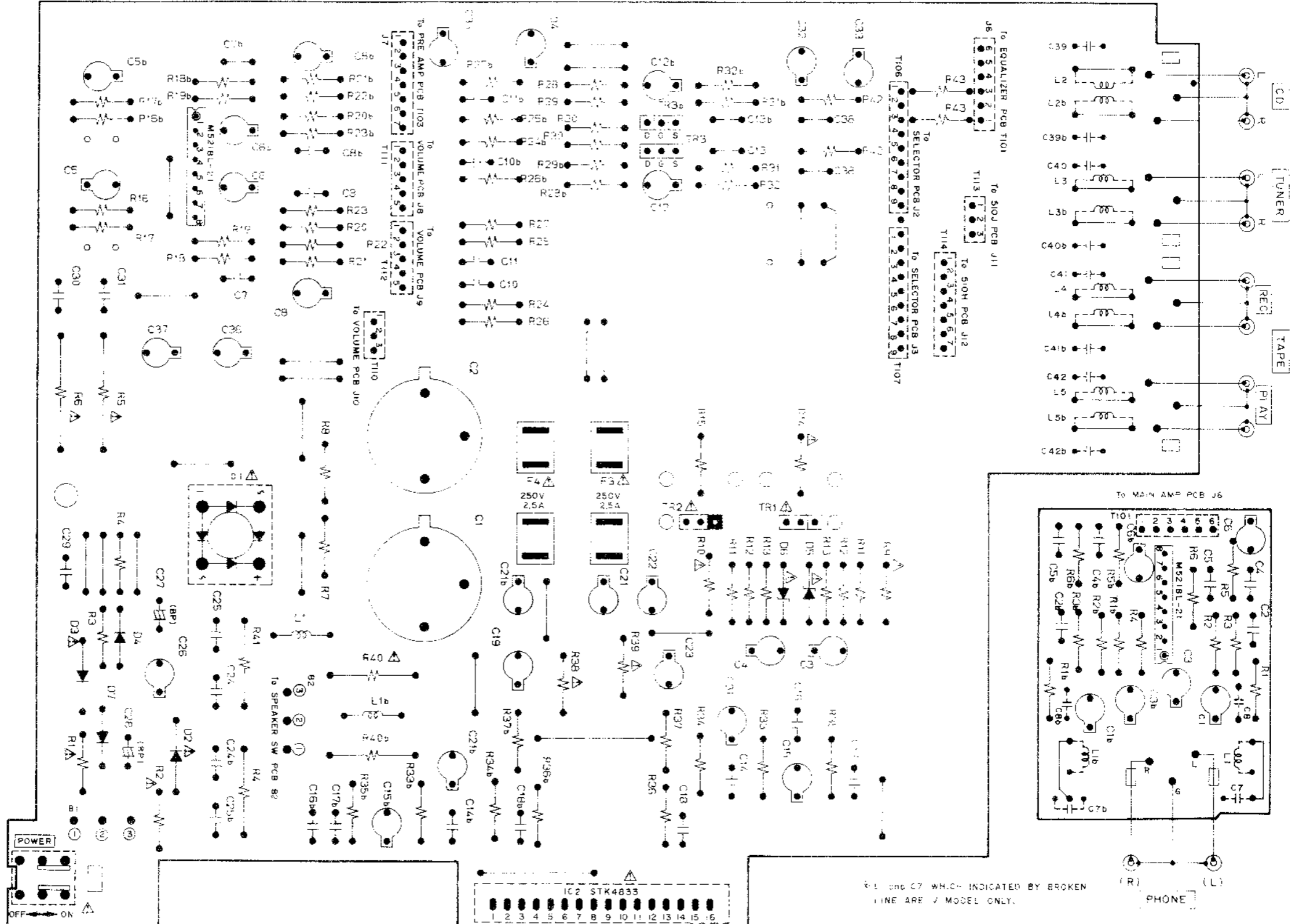
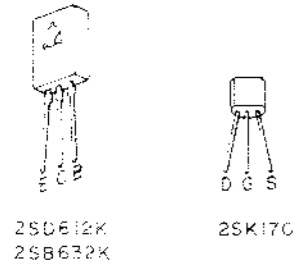

* C1 and C7 WHICH INDICATED BY BROKEN LINE ARE [V] MODEL ONLY.

EQUALIZER PCB

- A2030A501B [U]
- A2030A502B [C] [A]
- A2030A503B [E] [B] [S]
- A2030A504B [V]

WARNING: DO NOT USE SAFETY CRITICAL COMPONENTS FOR POINT TO POINT REPAIRS. REPLACE SAFETY CRITICAL COMPONENTS ONLY WITH MANUFACTURER'S RECOMMENDED PARTS.

AVERTISSEMENT: NE PAS INDICER LES COMPOSANTS CRITIQUES DE SECURITE POUR MAINTENIR LE NIVEAU DE SECURITE DE L'APPAREIL. NE REMPLACER QUE LES COMPOSANTS RECOMMANDES PAR LE FABRICANT.