

AKAI STEREO HI-FI MUSIC CENTER

MODEL **AC-3800**

ALSO APPLICABLE TO MODEL AC-3800L

SECTION 1	SERVICE MANUAL	1
SECTION 2	PARTS LIST	41
SECTION 3	SCHEMATIC DIAGRAM	64

SECTION 1

SERVICE MANUAL

TABLE OF CONTENTS

I.	TECHNICAL DATA	2
II.	DISMANTLING OF UNIT	4
III.	CONTROLS	6
IV.	PRINCIPAL PARTS LOCATIONS	10
V.	OPERATING PRINCIPLES OF VARIOUS CIRCUITS	12
	1. DIFFERENTIAL PEAK DETECTOR	12
	2. VARACTOR TUNER AND PRESET TUNING SYSTEM	13
VI.	LEVEL DIAGRAM	16
VII.	TUNER ADJUSTMENT	17
	1. FM TUNER SECTION ADJUSTMENT FOR MODEL AC-3800 AND AC-3800L	18
	2. MW TUNER SECTION ADJUSTMENT FOR MODEL AC-3800	19
	3. LW, MW TUNER SECTION ADJUSTMENT FOR MODEL AC-3800L	20
VIII.	TUNING CORD THREADING	21
IX.	CASSETTE RECORDER MECHANISM ADJUSTMENT	22
	1. TAKE-UP TORQUE AT VARIOUS MODES AND TORQUE MEASURING METHOD	22
	2. TAPE SPEED ADJUSTMENT	22
	3. PINCH ROLLER PRESSURE MEASUREMENT	22
	4. ADJUSTMENT OF GAP BETWEEN THE PINCH ROLLER ARM AND STOPPER	22
	5. FLYWHEEL THRUST LOOSE PLAY ADJUSTMENT	23
X.	CASSETTE RECORDER HEAD ADJUSTMENT	24
XI.	CASSETTE RECORDER AMPLIFIER ADJUSTMENT	25
XII.	TURN TABLE SECTION ADJUSTMENT	27
	1. RETURN POSITION ADJUSTMENT	27
	2. OVERHANG ADJUSTMENT	27
	3. STYLUS PRESSURE ADJUSTMENT	27
XIII.	DC RESISTANCE OF VARIOUS COILS	28
XIV.	CLASSIFICATION OF VARIOUS P.C BOARDS	28

For basic adjustments measuring methods, and operating principles, refer to GENERAL OPERATING PRINCIPLES AND ADJUSTMENTS.

I. TECHNICAL DATA

1. RECEIVER SECTION

(AMPLIFIER)

CONTINUOUS POWER OUTPUT BOTH CHANNELS DRIVEN		25 watts per channel, min. RMS at 8 ohms from 40 to 20,000 Hz with no more than 0.5% T.H.D.
POWER BANDWIDTH (IHF)		10 to 40,000 Hz/8 ohms (T.H.D.: 0.5%)
SIGNAL TO NOISE RATIO (IHF)		
	TAPE MONITOR	Better than 90 dB
DAMPING FACTOR		More than 30 (1 kHz, 8 ohms)
OUTPUT	SPEAKER	A, B (4 to 16 ohms) / A+B (8 to 16 ohms)
	HEADPHONES	4 to 16 ohms
INPUT SENSITIVITY/IMPEDANCE		
	TAPE MONITOR	PIN: 150 mV/50 k ohms DIN: 150 mV/50 k ohms
OUTPUT LEVEL/IMPEDANCE	TAPE REC	PIN: 150 mV/ 4 k ohms DIN: 30 mV/30 k ohms
FREQUENCY RESPONSE	PHONO (RIAA)	30 Hz to 15 kHz \pm 1 dB
	TAPE MONITOR	10 Hz to 70 kHz +0/-2 dB
TONE CONTROL	BASS	\pm 10 dB at 100 Hz
	TREBLE	\pm 10 dB at 10 kHz

(TUNER)

FM		
FREQUENCY RANGE		88 MHz to 108 MHz
SENSITIVITY (IHF)		1.9 μ V
CAPTURE RATIO		1.5 dB
SELECTIVITY (IHF)		More than 50 dB
STEREO SEPARATION		More than 35 dB at 1 kHz
SIGNAL TO NOISE RATIO		65 dB
HARMONIC DISTORTION	MONO	Less than 0.3%
	STEREO	Less than 0.7%
IMAGE REJECTION		More than 65 dB
IF REJECTION		More than 90 dB
SPURIOUS REJECTION		More than 90 dB
AM SUPPRESSION		45 dB
MUTING		Switchable to ON-OFF
ANTENNA INPUT IMPEDANCE		300 ohms balanced, 75 ohms unbalanced
MW		
FREQUENCY RANGE		520 kHz to 1,605 kHz
SENSITIVITY (IHF)		180 μ V/m (Bar antenna), 10 μ V/m (Ext. antenna)
*LW		
FREQUENCY RANGE		150 kHz to 350 kHz
SENSITIVITY (IHF)		200 μ V/m (Bar antenna), 10 μ V/m (Ext. antenna)

2. CASSETTE RECORDER SECTION

TRACK SYSTEM	4 track 2 channel stereo system
WOW AND FLUTTER	0.08% WRMS (NAB), 0.24% (DIN 45507)
FREQUENCY RESPONSE	35 to 13,000 Hz \pm 3 dB using LN tape 35 to 14,000 Hz \pm 3 dB using CrO ₂ (SA) tape
DISTORTION	Less than 1.5% using LN tape (1 kHz/0 VU)
SIGNAL TO NOISE RATIO	51 dB using LN tape (Measured via tape with peak recording level of +3 VU) Dolby N.R. Switch on: Improves up to 10 dB above 5 kHz
ERASE RATIO	Better than 65 dB
BIAS FREQUENCY	75 kHz
HEADS	(2): One Recording/Playback Head, One Erase Head
MOTOR	(1): Electronically Speed Controlled DC Motor
INPUT SENSITIVITY/IMPEDANCE	MICROPHONE (2) 0.3 mV/2 kohms REQUIRED MICROPHONE IMPEDANCE 600 ohms

3. TURNTABLE SECTION

DRIVE SYSTEM	Auto-return, Belt Driven
MOTOR	4-pole synchronous motor
SPEED	33-1/3 and 45 r.p.m.
WOW AND FLUTTER	0.1% WRMS
RUMBLE	60 dB (DIN B)
PLATTER	300 mm
TONE ARM	Static balance type with inside force canceller
CARTRIDGE	MM type
FREQUENCY RESPONSE	20 Hz to 20 kHz
OVERHANG	9.4 mm
OPTIMAL STYLUS PRESSURE	2.0 grams

4. MISCELLANEOUS

SEMICONDUCTORS	Transistors: 27, Diodes: 27, ICs: 11, FET: 1
POWER REQUIREMENTS	CSA models: 120V/60 Hz CEE models: 220V/50 Hz Other models: 110/220/240V Switchable, 50/60 Hz
DIMENSIONS	550(W) × 220(H) × 467(D) mm 21.7(W) × 8.7(H) × 18.4(D) inches
WEIGHT	17.5 kg (38.5 lbs)

Note:

1. * Applicable to only Model AC-3800L
2. For improvement purpose, specifications and design are subject to change without notice.
3. "DOLBY" and the Double D symbol are trademarks of Dolby Laboratories, Inc.
(Under License from Dolby Laboratories, Inc.)

II. DISMANTLING OF UNIT

In case of trouble, etc. necessitating disassembly, please disassemble in the order shown in photographs. Reassemble in reverse order.

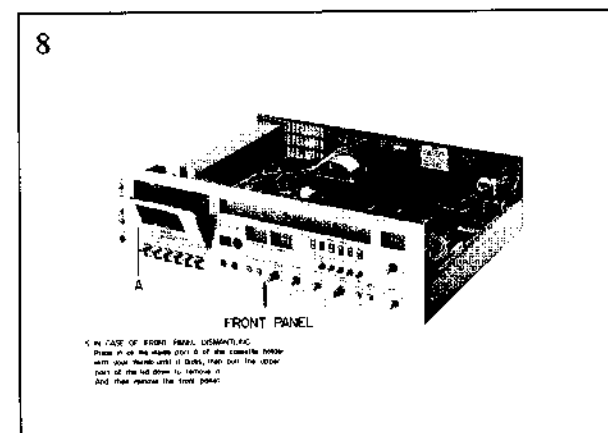
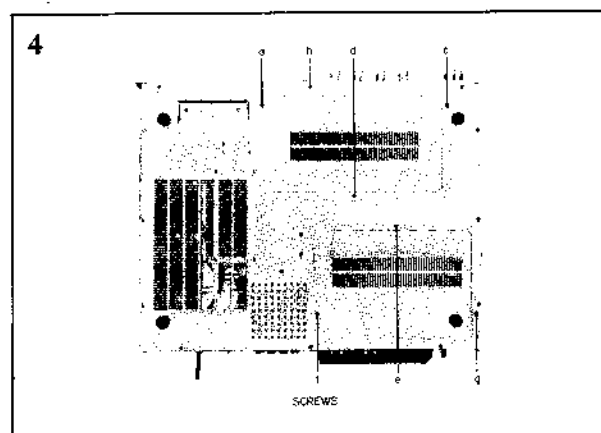
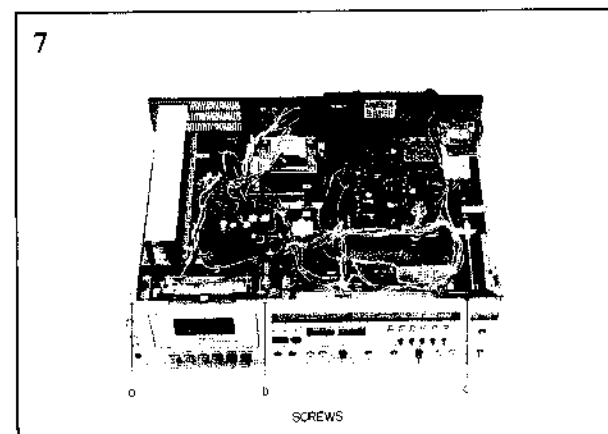
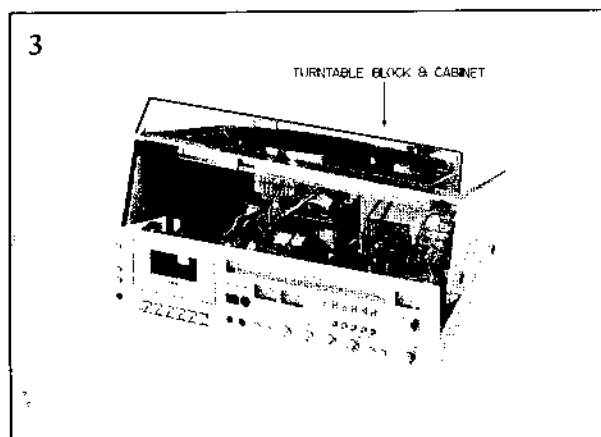
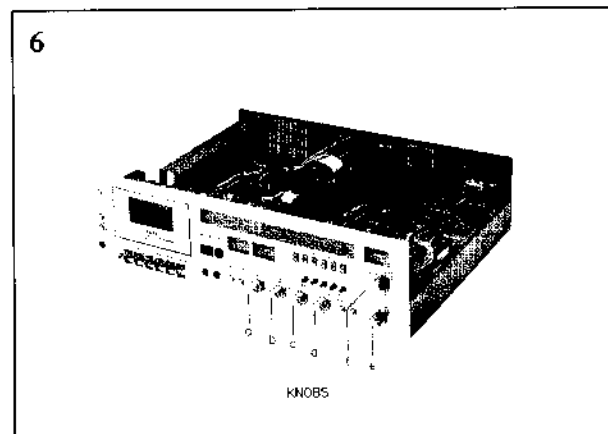
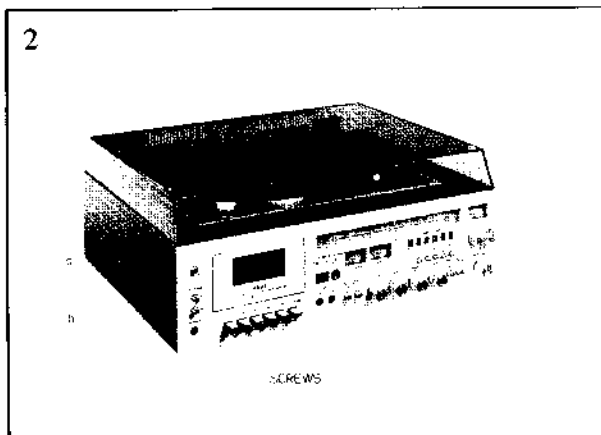
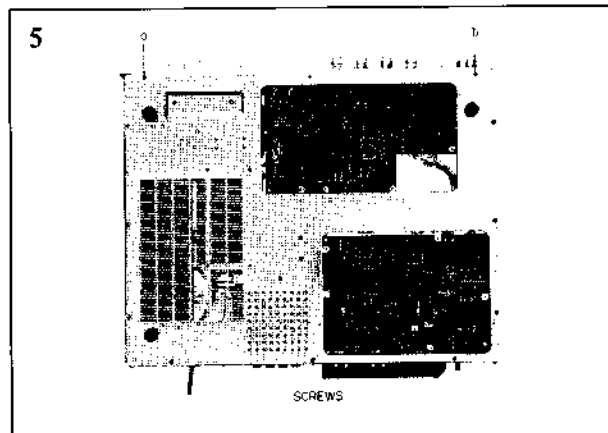
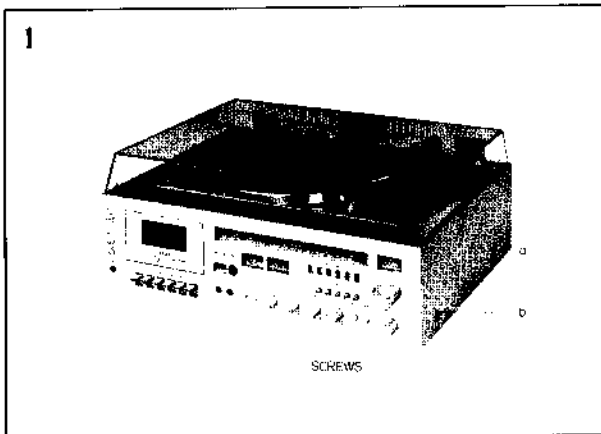

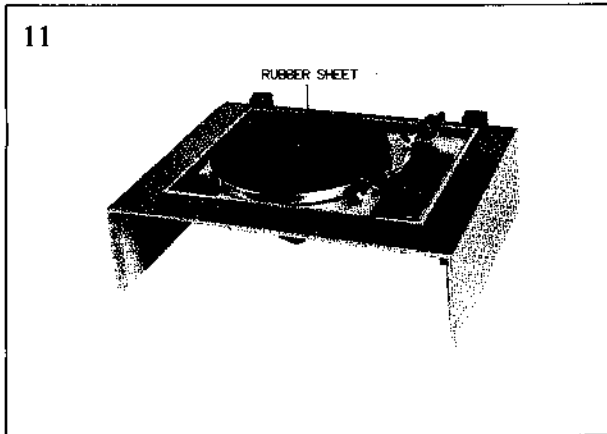
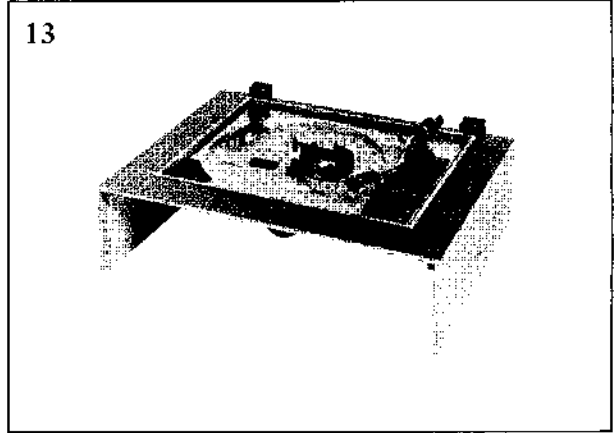
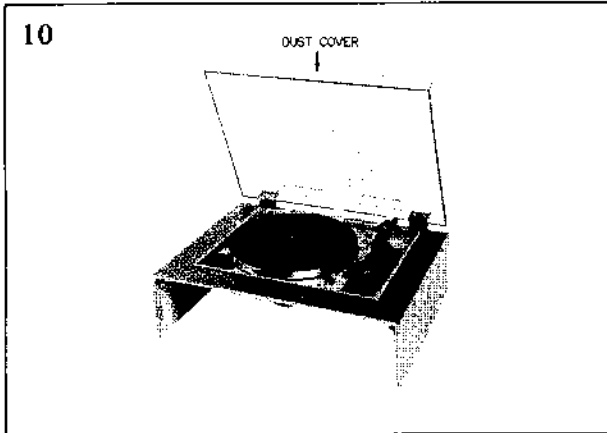
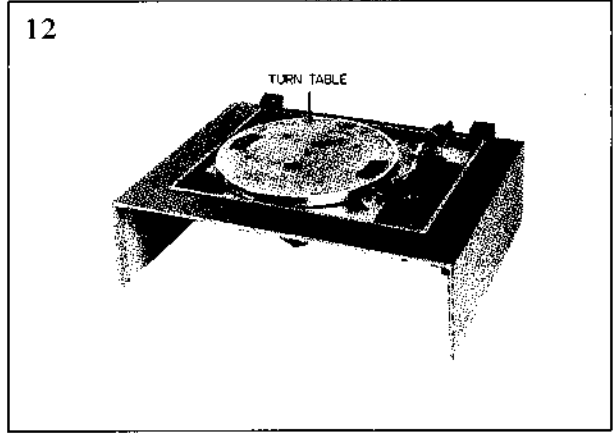
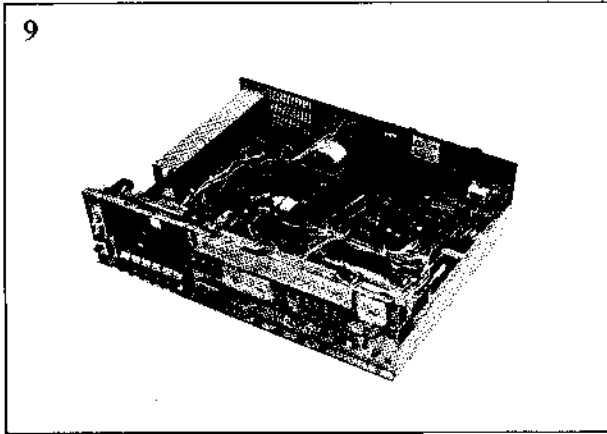

III. CONTROLS

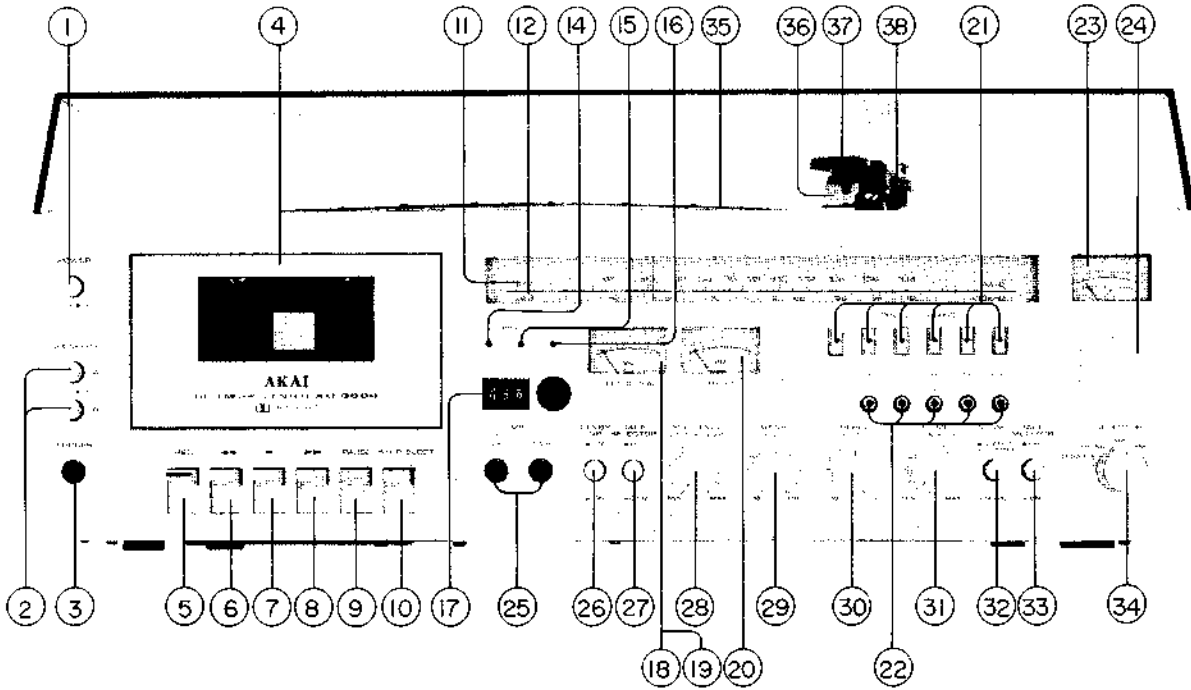

Fig. 1 AC-3800

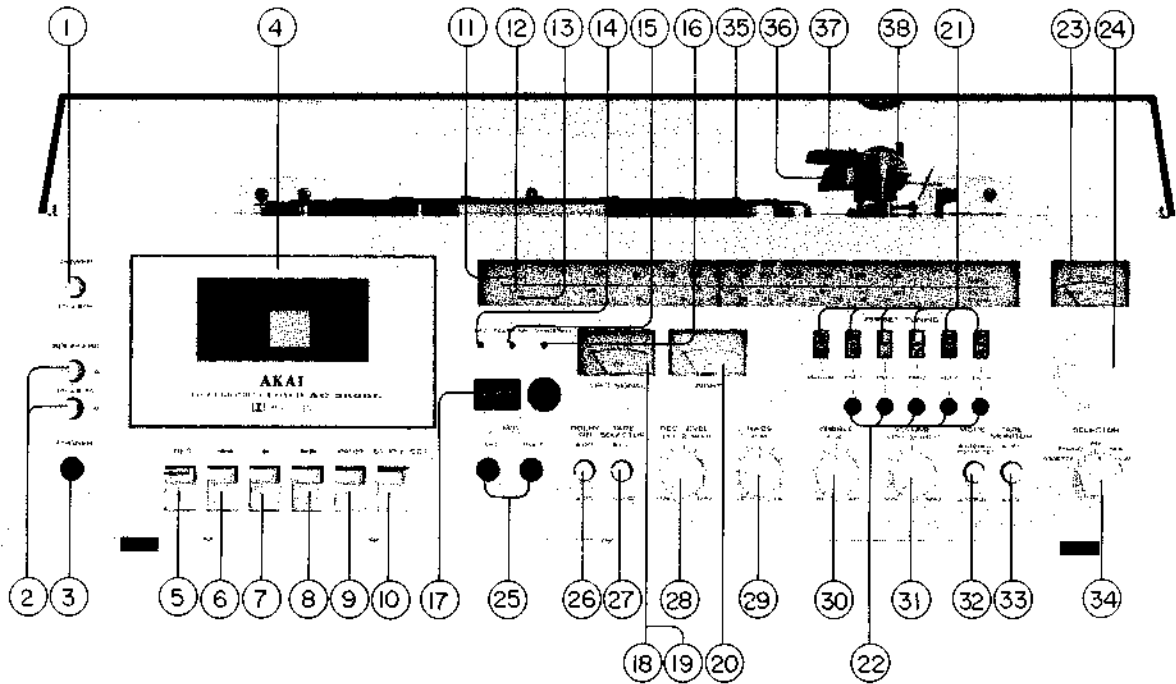

Fig. 2 AC-3800L

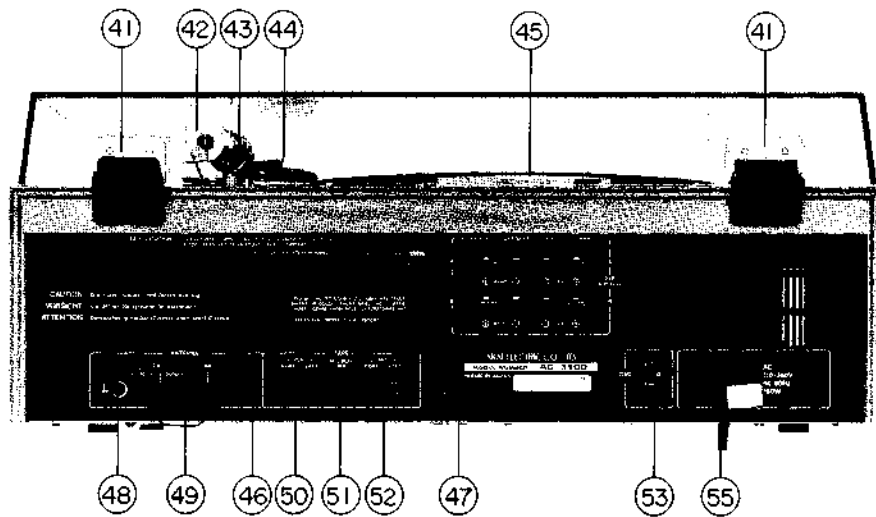

Fig. 3 AC-3800

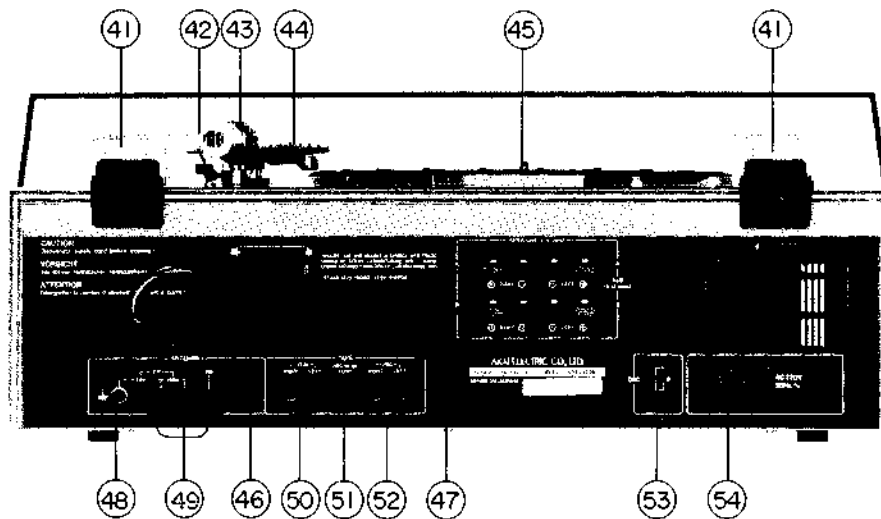

Fig. 4 AC-3800L

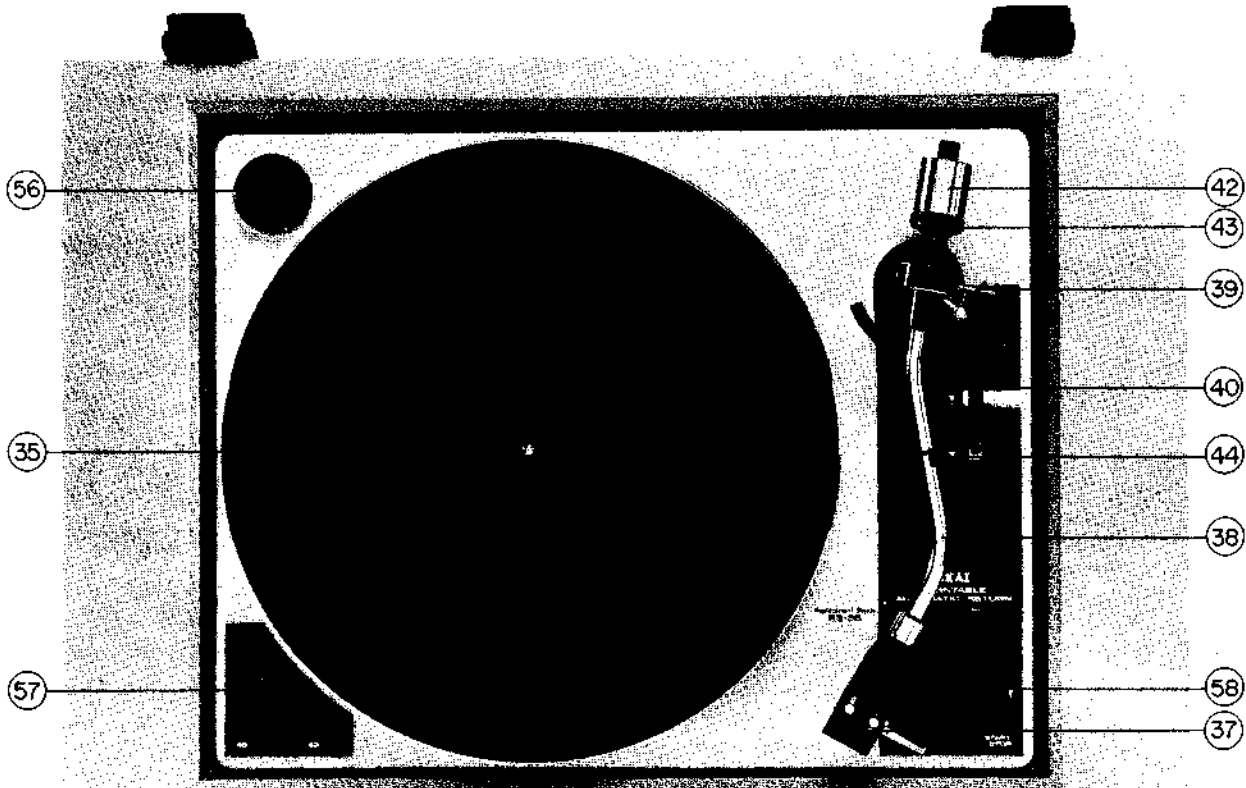

Fig. 5

AC-3800

1. POWER SWITCH
2. SPEAKER SYSTEM SELECTOR
3. HEADPHONE JACK
4. CASSETTE RECEPTACLE (with tape view window)
5. RECORDING (REC) KEY
6. REWIND KEY
7. PLAY KEY
8. FAST FORWARD KEY
9. PAUSE KEY
10. STOP/EJECT KEY
11. FM DIAL SCALE
12. AM DIAL SCALE (medium wave)
14. RECORDING INDICATOR LAMP
15. DOLBY N.R. INDICATOR LAMP
16. FM STEREO LAMP
17. INDEX COUNTER AND RESET BUTTON
18. FM/MW/LW (FM/AM) TUNING METER
19. LEFT VU METER
20. RIGHT VU METER
21. FM PRESET TUNING SYSTEM
22. FM PRESET TUNING KNOB
23. FM PRESET TUNING INDICATOR
24. TUNING KNOB
25. MICROPHONE JACKS (left and right)
26. DOLBY N.R. SWITCH
27. TAPE SELECTOR SWITCH
28. LEFT RECORDING LEVEL CONTROL
RIGHT RECORDING LEVEL CONTROL
29. BASS CONTROL KNOB
30. TREBLE CONTROL KNOB
31. VOLUME CONTROL (left and right)
32. MODE SWITCH (FM mute switch)
33. TAPE MONITOR SWITCH
34. SOURCE SELECTOR
35. TURNTABLE
36. CARTRIDGE
37. CARTRIDGE SHELL
38. TONE ARM
39. INSIDE FORCE CANCELLER
40. TONE ARM LIFTER LEVER
41. HINGE
42. MAIN WEIGHT
43. STYLUS PRESSURE SCALE RING
44. ARM REST
45. SPINDLE
46. AM FERRITE BAR ANTENNA
47. A AND B SYSTEM SPEAKER TERMINALS
48. GROUND TERMINAL
49. ANTENNA TERMINAL
50. TAPE PLAY JACK
51. TAPE SYSTEM DIN JACK
52. TAPE REC JACK
53. BEAT CUT-OFF SWITCH (OSC)
55. AC CORD
56. 45 rpm ADAPTER
57. SPEED SELECTOR
58. START/STOP LEVER

AC-3800L

1. POWER SWITCH
2. SPEAKER SYSTEM SELECTOR
3. HEADPHONE JACK
4. CASSETTE RECEPTACLE (with tape view window)
5. RECORDING (REC) KEY
6. REWIND KEY
7. PLAY KEY
8. FAST FORWARD KEY
9. PAUSE KEY
10. STOP/EJECT KEY
11. FM DIAL SCALE
12. AM DIAL SCALE (medium wave)
13. AM DIAL SCALE (long wave)
14. RECORDING INDICATOR LAMP
15. DOLBY N.R. INDICATOR LAMP
16. FM STEREO LAMP
17. INDEX COUNTER AND RESET BUTTON
18. FM/MW/LW (FM/AM) TUNING METER
19. LEFT VU METER
20. RIGHT VU METER
21. FM PRESET TUNING SYSTEM
22. FM PRESET TUNING KNOB
23. FM PRESET TUNING INDICATOR
24. TUNING KNOB
25. MICROPHONE JACKS (left and right)
26. DOLBY N.R. SWITCH
27. TAPE SELECTOR SWITCH
28. LEFT RECORDING LEVEL CONTROL
RIGHT RECORDING LEVEL CONTROL
29. BASS CONTROL KNOB
30. TREBLE CONTROL KNOB
31. VOLUME CONTROL (left and right)
32. MODE SWITCH (FM mute switch)
33. TAPE MONITOR SWITCH
34. SOURCE SELECTOR
35. TURNTABLE
36. CARTRIDGE
37. CARTRIDGE SHELL
38. TONE ARM
39. INSIDE FORCE CANCELLER
40. TONE ARM LIFTER LEVER
41. HINGE
42. MAIN WEIGHT
43. STYLUS PRESSURE SCALE RING
44. ARM REST
45. SPINDLE
46. AM FERRITE BAR ANTENNA
47. A AND B SYSTEM SPEAKER TERMINALS
48. GROUND TERMINAL
49. ANTENNA TERMINAL
50. TAPE PLAY JACK
51. TAPE SYSTEM DIN JACK
52. TAPE REC JACK
53. BEAT CUT-OFF SWITCH (OSC)
54. AC INLET (CEE models)
56. 45 rpm ADAPTER
57. SPEED SELECTOR
58. START/STOP LEVER

IV. PRINCIPAL PARTS LOCATIONS

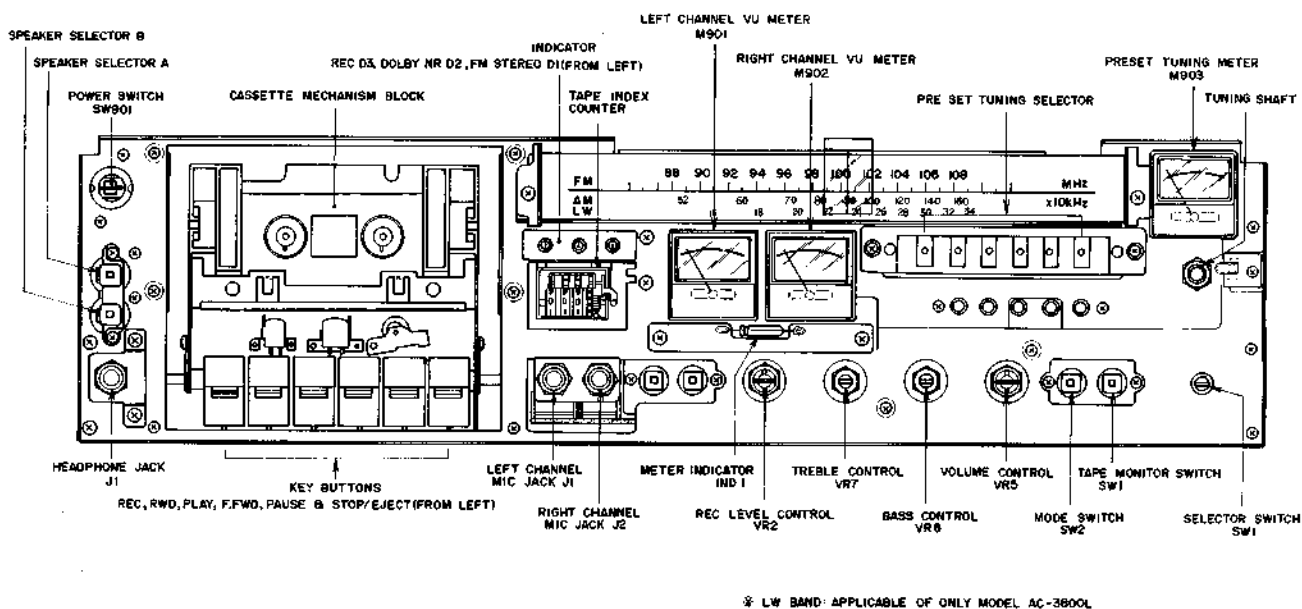

Fig. 6 Front View

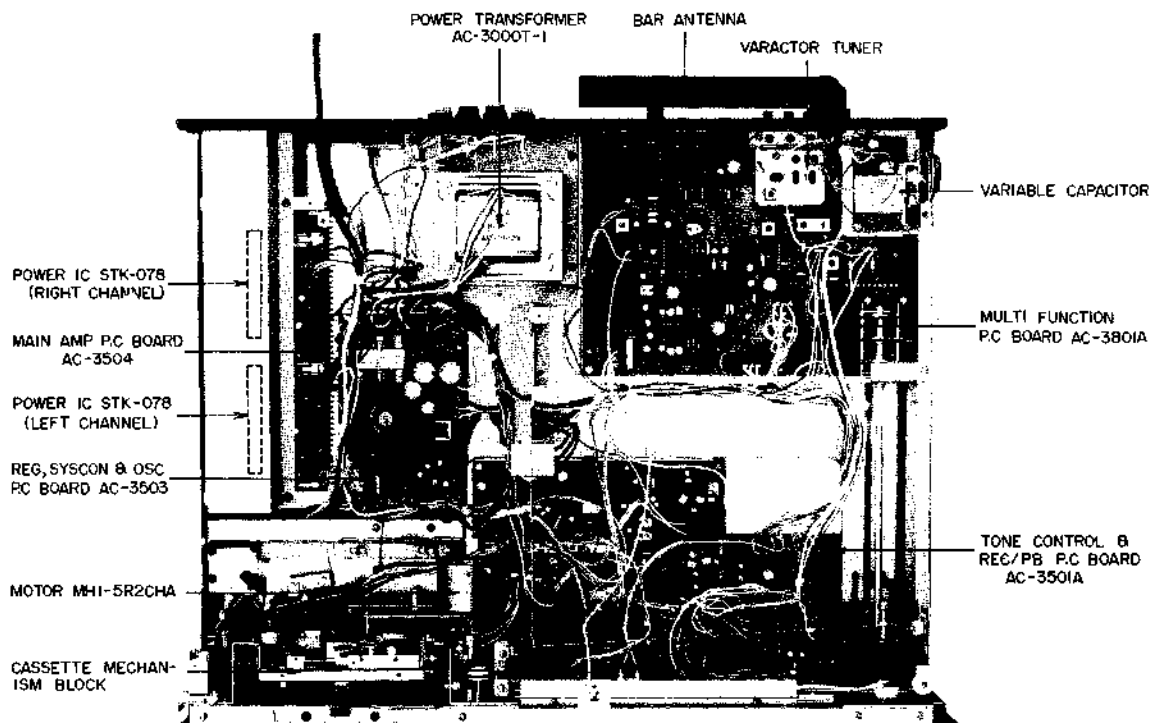

Fig. 7 Top View of Model AC-3800

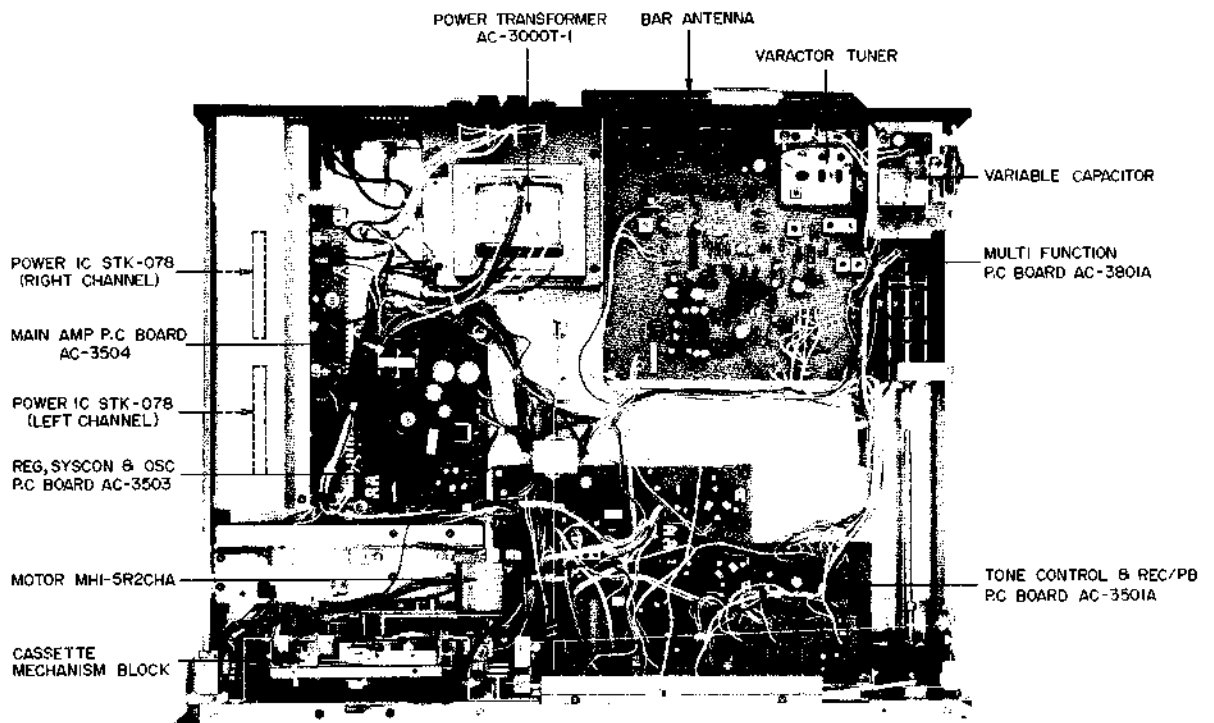

Fig. 8 Top View of Model AC-3800L

V. OPERATING PRINCIPLES OF VARIOUS CIRCUITS

1. DIFFERENTIAL PEAK DETECTOR OPERATION

1) CIRCUIT CONFIGURATION

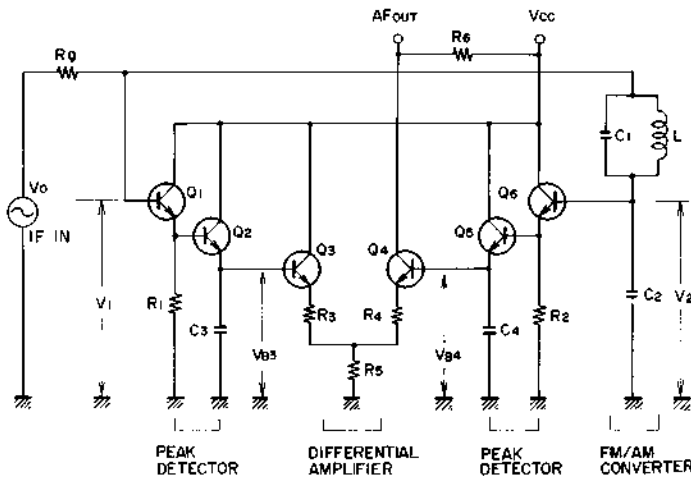

Fig. 9 IC2 (TA7303P) Detector Equivalent Circuit

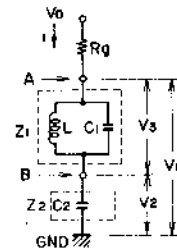

Fig. 10

2) OPERATION

As shown in Fig. 9, FM Signals of IF output voltage are converted into AM signals due to the resonance frequency characteristics of series resonance in circuit L (constituting an LC circuit) and circuits C₁, C₂ and parallel resonance in circuits L and C₁.

As can be understood in Fig. 10, the circuit impedance is at minimum in the vicinity of series resonance frequency f_L. Thus, the following approximation is obtained:

$$Z_1 + Z_2 \approx 0 \quad (1)$$

And, circuit current i can be expressed as follows:

$$i = V_0 / R_0 \quad (2)$$

When expressing the voltages across A and B, and across B and GND as V₃ and V₂ respectively, the following are obtained:

$$V_3 = V_1 - V_2 = Z_1 \cdot i \quad (3)$$

$$V_2 = Z_2 \cdot i \quad (4)$$

Provided that the voltage across A and GND equals V₁, and formula (5) is obtained from (1), (3) and (4).

$$V_1 = (Z_1 + Z_2) i = 0 \quad (5)$$

Therefore, comparing formula (4) and (5), the following is obtained:

$$|V_2| \gg |V_1|$$

As is clear from formula (1), (3) and (4), voltage V₃ across A and B and voltage V₂ across B and GND are equal in amplitude, and out of phase. Accordingly, voltage V₁ across A and GND is cancelled approximately to zero.

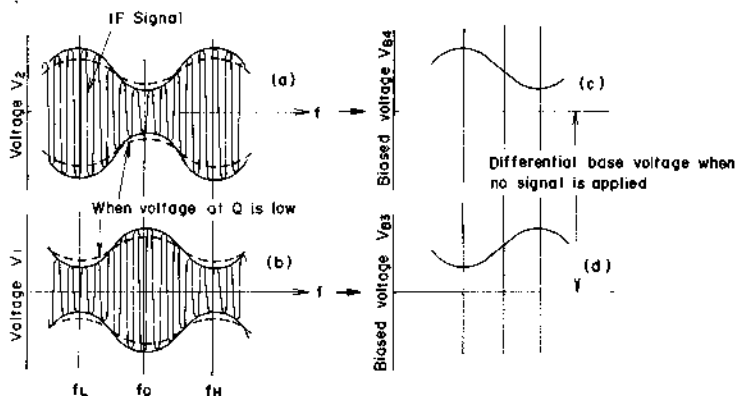

Fig. 11

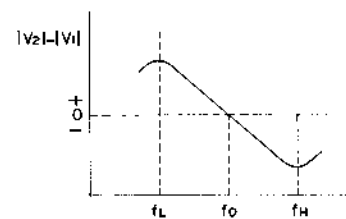

Fig. 12

The circuit is arranged so that voltage V_1 across A and GND and voltage V_2 across B and GND are equal in absolute value, and out of phase when IF frequency is 10.1 MHz ($=f_0$):

Because the impedance across A and B is infinity with parallel resonance frequency f_H , voltage V_2 across B and GND is approximately zero V. Thus, the following is obtained.

$$|V_1| \gg |V_2|$$

As explained above, FM signals of IF output pass through the LC series/parallel circuits included in Fig. 9, where their waveforms become as shown in Fig. 11 (a) and (b), while the signals are converted into AM signals.

The AM signals converted are then fed the bases of transistors Q_2 and Q_5 through the emitter-followers of transistors Q_1 and Q_2 as indicated in Fig. 9.

Capacitors C_3 and C_4 in circuits Q_2 and Q_5 eliminate IF signals, and detect the peak signals thereby providing waveforms like those shown in Fig. 11 (c) and (d).

They are then fed to the bases of transistors Q_3 and Q_4 included in the differential amplifier circuit, which amplifies the signals. A band width is specified for the differential circuit and, when inputs such as shown in Fig. 11 (c) and (d) are applied to the bases of transistors Q_3 and Q_4 ,

the amplifier output exhibits S-curve characteristics as shown in Fig. 12. As the S-curve in Fig. 12 becomes sharper, the output becomes saturated at a frequency nearer to f_0 , thus permitting the band width to be narrower and providing a larger detection output.

2. VARACTOR TUNER AND PRESET TUNING SYSTEM

1) VARACTOR TUNER

A varactor tuner is the tuner system in which varactor diode junction capacitance is varied by means of the inverse bias value applied to the diode for station selection. By employing a varactor diode, tuning which is same as ordinary variable condenser system can be made without using a variable condenser by changing control voltage only.

(1) Features

- When used in an FM tuner, the front end can be made smaller than when compared with a variable condenser.
- Station selector button positioning is not limited.
- Station selection by remote control is possible.
- Ideal voltage can be set for a certain reception frequency beforehand, and preset tuning can be effected by successively switching the control voltage.
- If control voltage sweep is at ideal speed, automatic tuning (search tuning) is possible.
- Power consumption is about the same as a variable condenser system.

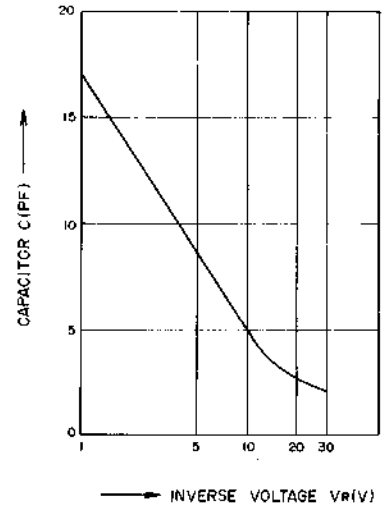

Fig. 13

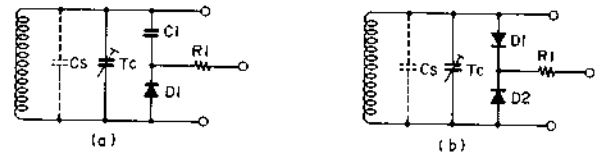

Fig. 14 Tuning circuit employing a varactor diode

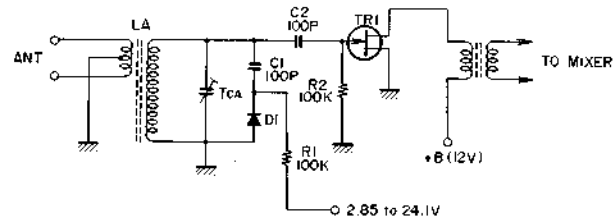

Fig. 15 Example of High Frequency Amplifier Stage Circuit

(2) Varactor Diode Characteristics

As for varactor diode characteristics, as shown in Fig. 13, capacitance C is changed by change in inverse bias value applied to the diode for station selection. Further, if this varactor diode is used in a tuning circuit, the following conditions are necessary.

$$\frac{C_{\max} + C_D}{C_{\min} + C_D} = \left(\frac{f_{\max}}{f_{\min}} \right)^2 = K$$

C_{\max} , C_{\min} are the maximum and minimum values of varactor diode capacitance change. C_D is the sum of stray capacitance and trimmer capacitance. K is over 1.5 because FM broadcast frequency range is 88 to 108 MHz. Figs. 14(a) and 14(b) show the actual usage method.

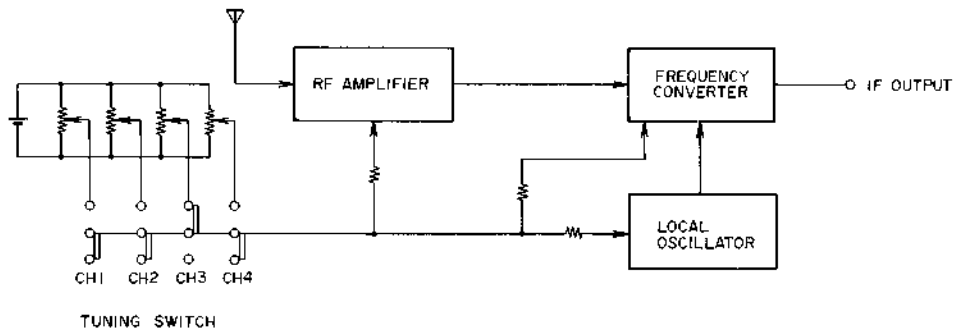

Fig. 16 Block Diagram

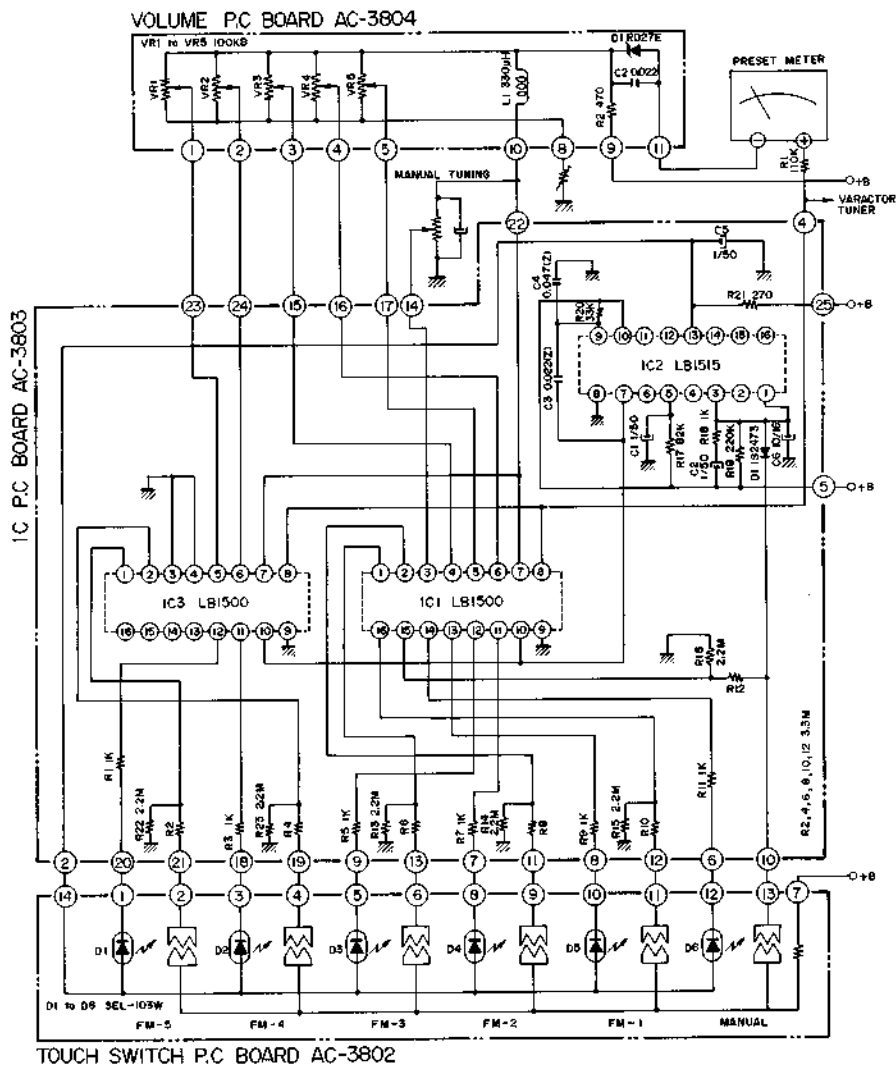

Fig. 17

(3) Actual Operation

Fig. 15 is a circuit diagram of the high frequency amplifier stage only of a circuit which is actually used. Condenser C1 and varactor diode D1 in the diagram are equivalent to the variable condenser of an ordinary FM front end. As can be understood from Fig. 13, D1 varies the capacitance in a 4 to 16 PF range by means of inverse bias voltage. This capacitance and condenser C1 combined capacitance forms the resonance circuit with coil LA. Consequently, it is satisfactory if at low resonance frequency, the

voltage supplied to the varactor diode declines, and at high resonance frequency, the voltage supplied to the varactor diode increases. This voltage variation method with variable resistor, etc., operates in the same way as a regular variable condenser. This method uses a local oscillator circuit and frequency mixer circuit, and bias voltage is applied to the varactor diode for station selection and is called a varactor tuner. Please refer to the schematic diagram for actual circuit drawing.

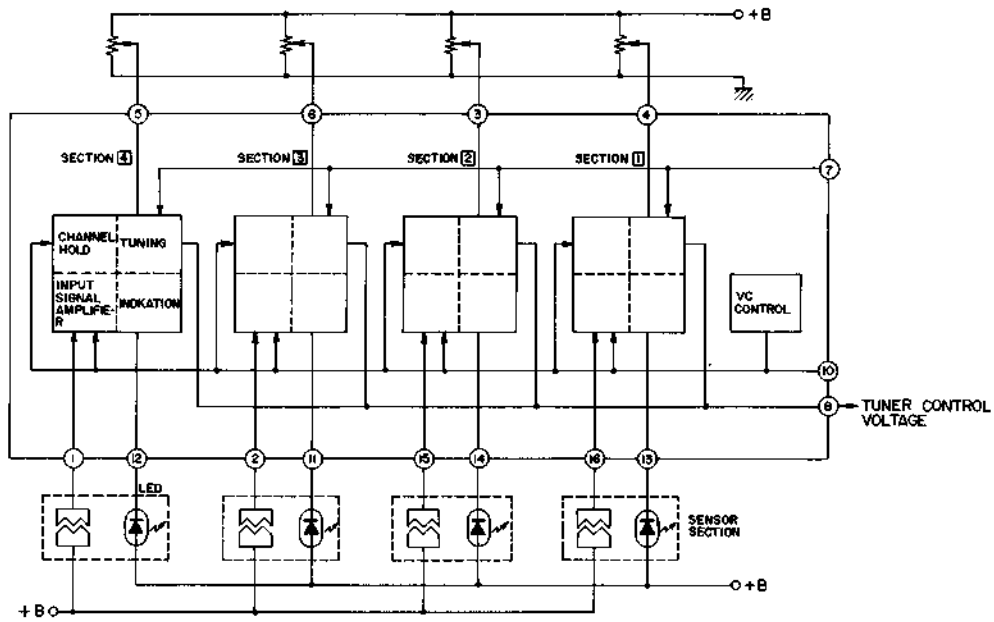

Fig. 18

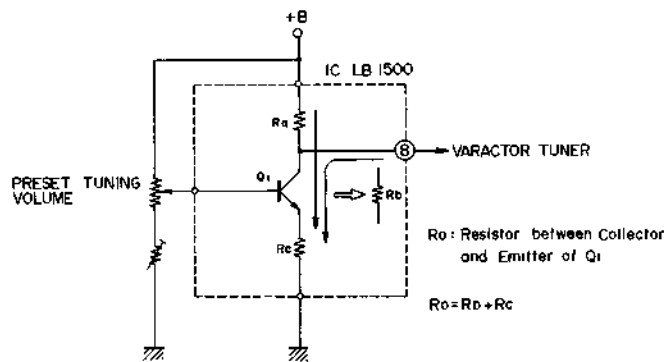

Fig. 19

2) PRESET TUNING SYSTEM

(1) Preset Station Selection

For preset station selection, there is a mechanical and an electrical method. These are memory equipment and selection equipment enabling desired station selection beforehand and selecting these pre-set stations by simply depressing the respective switches.

An ordinary car radio, etc. utilizes a mechanical station selection system wherein mechanical variation is by means of a variable condenser or positioning of a dust core inside a coil.

Model AC-3800, AC-3800L utilizes an electrical station selection system and employs the varactor tuner explained in a previous item.

(2) An example of a station selection system employing a varactor tuner is shown in Fig. 16. For station selection, push switches are used for selection of voltage supply to the varactor tuner. However, in the AC-3800, AC-3800L, these station selection push switches are pure electronic system sensi-touch switches.

(3) Sensi-touch Employed Preset Station Selection System Operation

The circuit shown in Fig. 17 is the control voltage generating preset volume and sensi-touch circuit. Fig. 18 shows the inside of circuit sensi-touch IC LB1500 which include the 4 channel circuitry. Terminals ①, ②, ⑮ and ⑯ are the input terminals; terminals ⑧ are the station selection output terminals; and terminals ⑪ through ⑭ are the pilot output terminals.

When channel 1 sensor electrode is touched, voltage is supplied to the IC as the input signal through finger (body) resistance at terminal ⑯. Then, the impedance is lowered at IC station selector output terminal ⑧ and current flows as shown by the arrow marks in Fig. 19. Consequently, because the supply voltage to the varactor tuner diode is changed by the dividing ratio of R_a and R_o , station selection is possible by means of setting the preset volumes beforehand according to the desired broadcast frequencies.

VI. LEVEL DIAGRAM

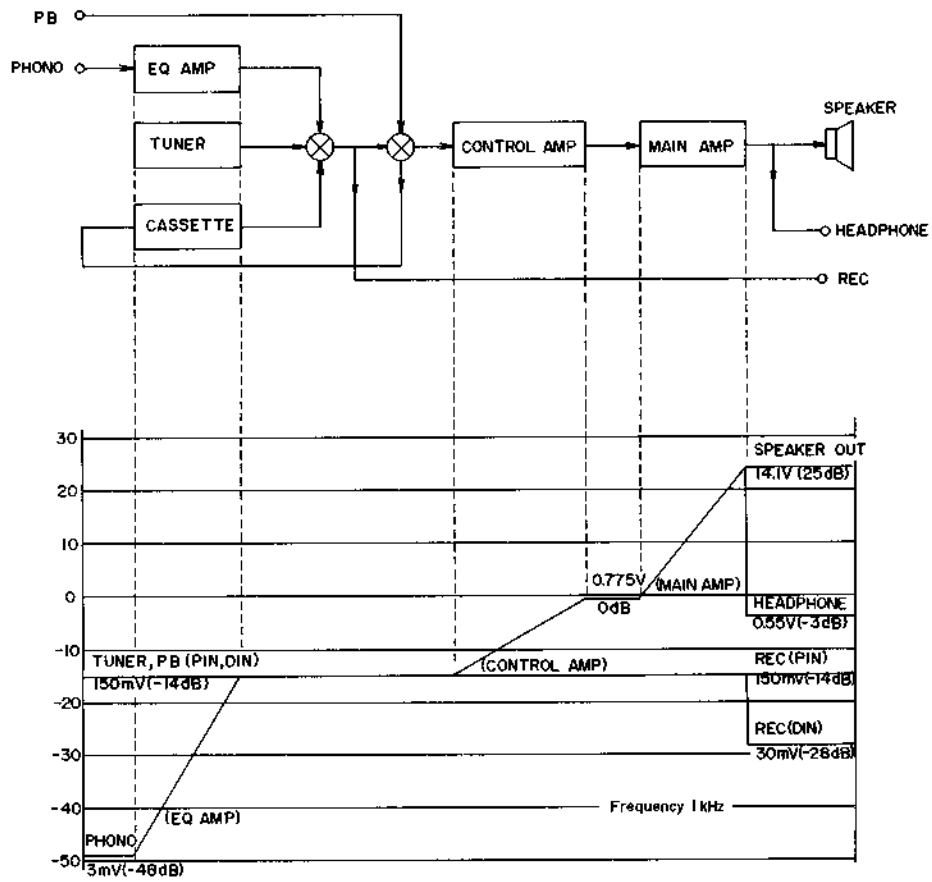

Fig. 20 Level Diagram of Model 3800/L

VII. TUNER ADJUSTMENT

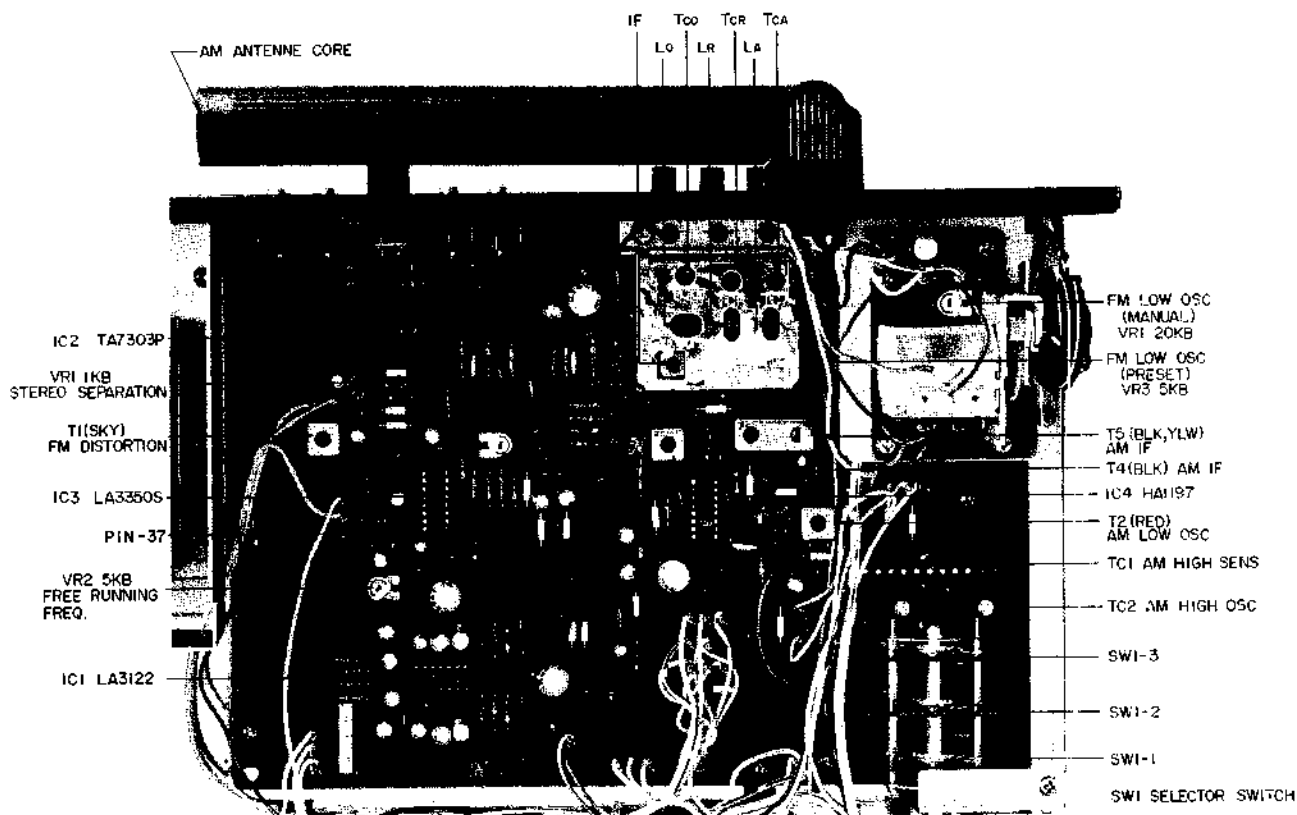

Fig. 21 Model AC-3800

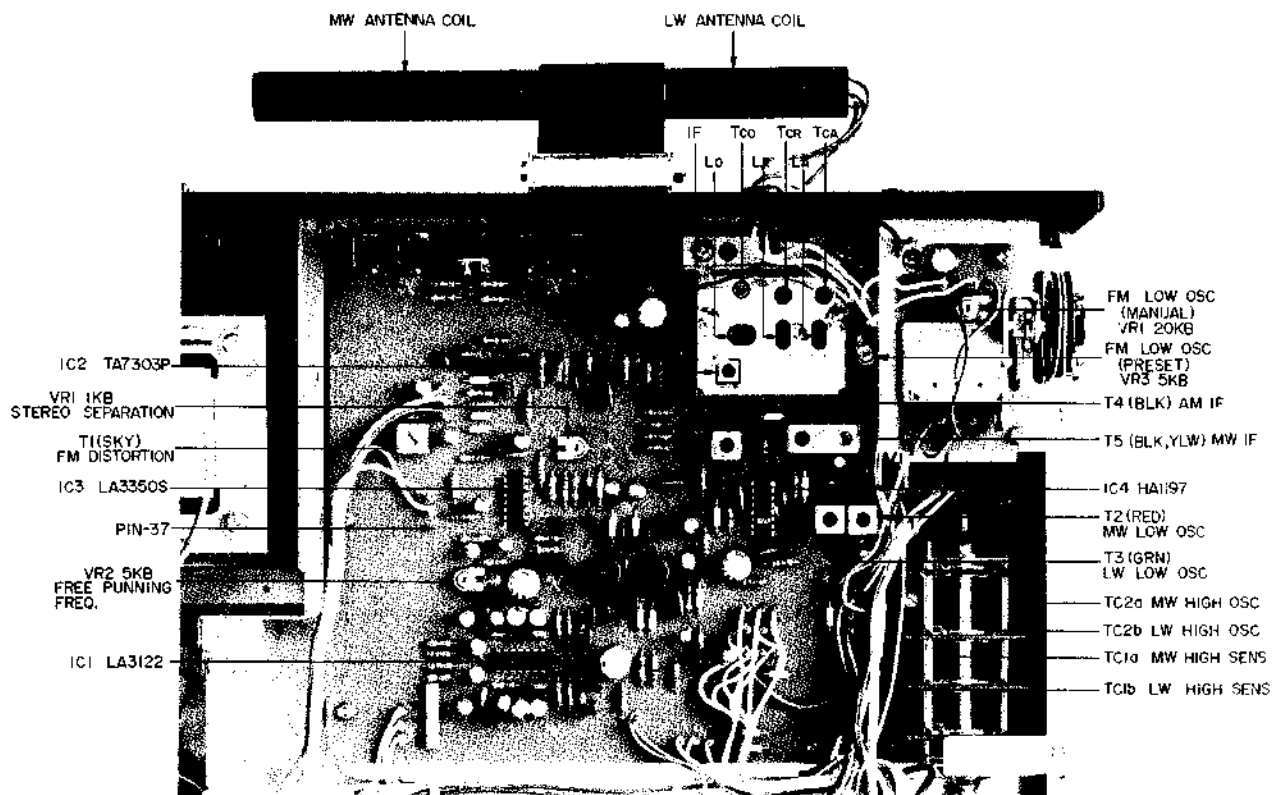

Fig. 22 Model AC-3800L

1. FM TUNER SECTION ADJUSTMENT FOR MODEL AC-3800 & AC-3800L
 (Refer to Figs. 21, 22)

Step	Adjustment Item	Adjustment Point	Result	Remarks
1	Front End IF Coil	IF Coil (Front End)	Maximum Noise Level	SELECTOR to "FM". MODE to "MONO". Set dial to where there is no broadcast signal.
2	High Range Scale Indication	Tco Trimmer Condenser (Front End)		108 MHz, 60 dB (mono) input. TUNING INDICATOR to 108 MHz. Error: ± 250 kHz
3	Manual Low Range Scale Indication	VR1 20 kB (AC-3801B)		88 MHz, 60 dB (mono) input. TUNING INDICATOR to 88 MHz. Error: ± 250 kHz
4	Preset Low Range Scale Indication	VR3 5 kB (AC-3801A)		87.4 MHz, 60 dB (mono) input "Preset Tuning" to "FM-1" and turn the Preset tuning knob fully counterclockwise.
5	High Range Sensitivity	Tca, Tcr Trimmer Condensers (Front End)	Less than 3% Distortion Factor	108 MHz, 14 dB (mono) input.
6	Confirmation of Low Range Sensitivity		Less than 3% Distortion Factor	88 MHz, 14 dB (mono) input. See NOTE 1.
7	Distortion Factor	T1 (SKY Core)	Less than 0.5% Distortion Factor	98 MHz, 60 dB (mono) input. See NOTE 2.
8	PLL Free Running Frequency	VR2 5 kB (AC-3801A)	19.00 kHz	Frequency Counter to Tuner P.C Board Pin 37. MODE to "STEREO (FM MUTE)"
9	Stereo Indicator Lighting Confirmation		Stereo Indicator (IND 1) lights	98 MHz, 60 dB (stereo) input. No stereo separation when stereo indicator does not light.
10	Stereo Separation (Left channel)	VR1 1 kB (AC-3801A)	More than 35 dB	98 MHz, 60 dB (stereo) right channel input. Less than 0.7% distortion Factor. See NOTE 2.
11	Stereo Separation (Right channel)		More than 35 dB	98 MHz, 60 dB (stereo) left channel input. Less than 0.7% Distortion Factor. See NOTE 2.
12	Confirmation of Signal Meter Indication		0 VU to 1 VU indication	98 MHz, 100 dB (mono) input.

Chart 1

- NOTES: 1. When the specified sensitivity of 14 dB cannot be obtained at three frequency points of 88 MHz, 98 MHz, and 108 MHz repeat adjustment in Step 5.
 2. When the distortion factor of the stereo separation still do not comply with the data specifications, adjust by turning the Front End FM IF coil core but not more than 1/2 turn.

2. MW TUNER SECTION ADJUSTMENT FOR MODEL AC-3800 (Refer to Fig. 21)

Step	Adjustment Item	Adjustment Point	Result	Remarks
1	Low Range Scale Indication	T2 (RED core) (AC-3801A)	Maximum Output	SELECTOR to "AM". 600 kHz. 50 dB input. TUNING INDICATOR to 600 kHz. Error within 2%.
2	Low Range Sensitivity	T5 (YLW, BLK core) T4 (BLK core) (AC-3801A), Bar antenna core (rear panel)	Maximum Output, minimum distortion factor	600 kHz, 50 dB input. Less than 10% distortion factor.
3	High Range Scale Indication	TC2 Trimmer Condenser (AC-3801A)	Maximum Output	1,400 kHz, 50 dB input. TUNING INDICATOR to 1,400 kHz. Error within 2%.
4	High Range Sensitivity	TC1 (AC-3801A)	Maximum Output, minimum distortion factor	1,400 kHz, 50 dB input. Less than 10% distortion factor.

Chart 2

3. LW AND MW TUNER SECTION ADJUSTMENT FOR MODEL AC-3800L (Refer to Fig. 22)

Step	Adjustment Item	Adjustment Point	Result	Remarks
1	LW Low Range Scale Indication	T3 (GRN core) (AC-3801A)	Maximum Output	SELECTOR to "LW". 160 kHz 50 dB input. TUNING INDICATOR to 160 kHz. Error within 2%
2	LW Low Range Sensitivity	T5 (YLW, BLK core) (AC-3801A) Bar antenna core (rear panel)	Maximum Output, Minimum distortion factor	160 kHz, 50 dB input. Less than 10% distortion factor.
3	LW High Range Scale Indication	TC2b Trimmer Condenser (AC-3801A)	Maximum Output	340 kHz 50 dB input. Tuning Indicator to 340 kHz. Error within 2%.
4	LW High Range Sensitivity	TC1b Trimmer Condenser (AC-3801A)	Maximum Output, Minimum distortion factor	340 kHz, 50 dB input. Less than 10% distortion factor.
5	MW Low Range Scale Indication	T2 (RED core) (AC-3801A)	Maximum Output	SELECTOR to "MW". 600 kHz 50 dB input, TUNING INDICATOR to 600 kHz, Error within 2%.
6	MW Low Range Sensitivity	Bar antenna core (rear panel)	Maximum Output, Minimum distortion factor	600 kHz, 50 dB input. Less than 10% distortion factor.
7	Low Range Scale Indication	T2 (RED core) (AC-3801A)	Maximum Output	SELECTOR to "MW". 600 kHz 50 dB input. TUNING INDICATOR to 600 kHz. Error within 2%.
8	Low Range Sensitivity	Bar antenna core (rear panel)	Maximum Output, Minimum distortion factor	600 kHz, 50 dB input. Less than 10% distortion factor.
9	High Range Scale Indication	TC2a Trimmer Condenser (AC-3801A)	Maximum Output	1,400 kHz, 50 dB input. TUNING INDICATOR to 1,400 kHz. Error within 2%
10	High Range Sensitivity	TC1a (AC-3801A)	Maximum Output, Minimum distortion factor	1,400 kHz, 50 dB input. Less than 10% distortion factor.

Chart 3

VIII. TUNING CORD THREADING

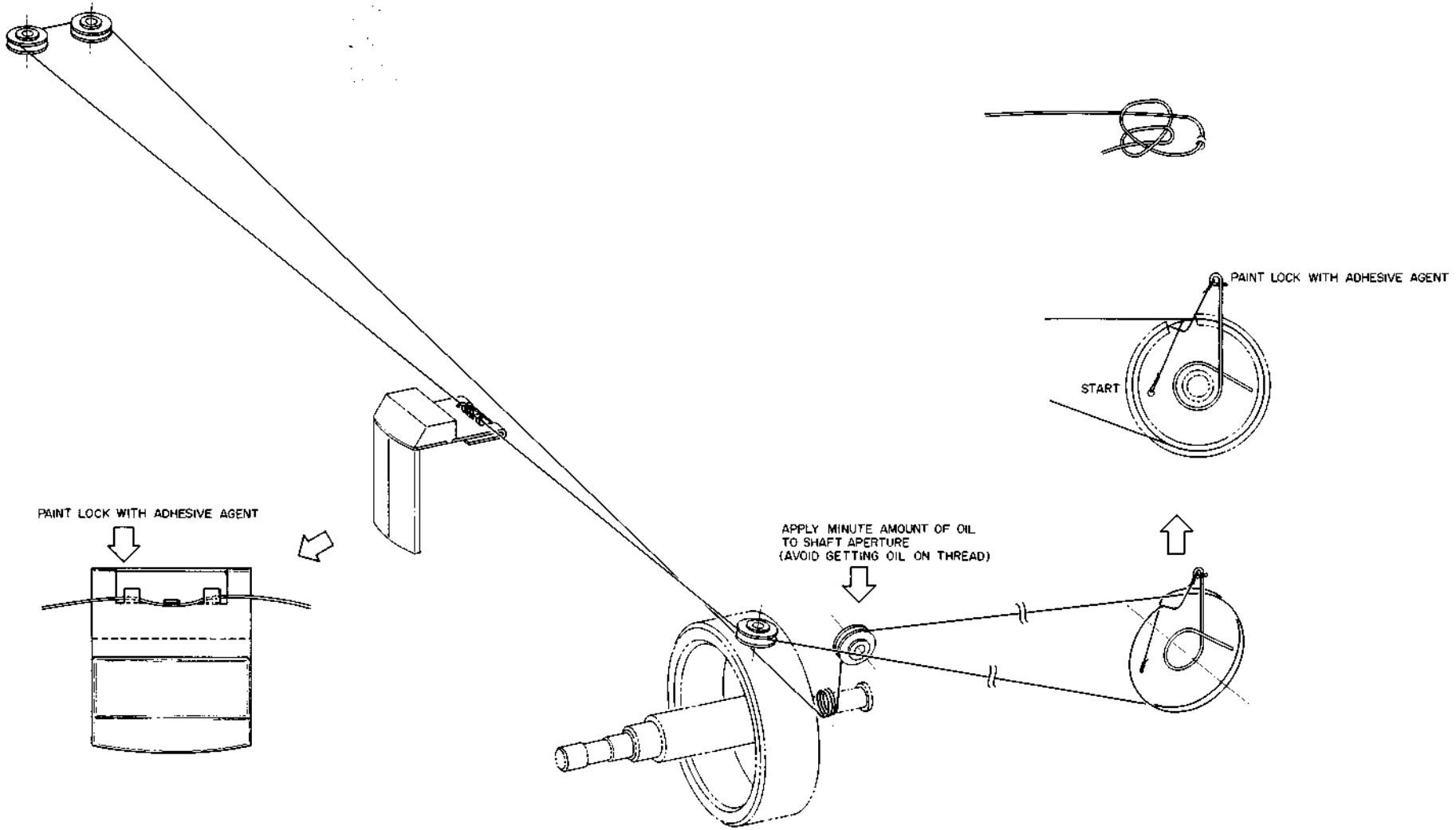

IX. CASSETTE RECORDER MECHANISM ADJUSTMENT

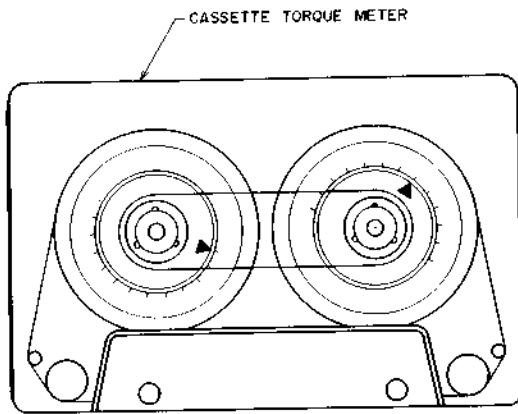

Fig. 23

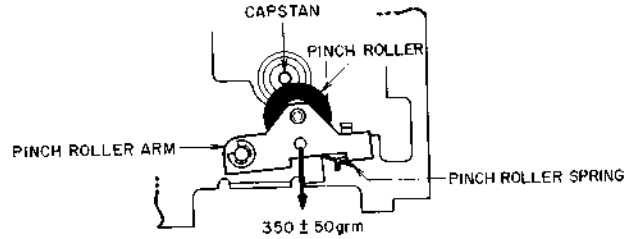

Fig. 25 Pinch Roller Pressure Measurement

1. TAKE-UP TORQUE AT VARIOUS MODES AND TORQUE MEASURING METHOD

As shown in Fig. 23, set a cassette torque meter on cassette base, and take a reading of the indication at each respective mode.

Playback mode	40 to 65 gm-cm
Fast Forward mode	70 to 130 gm-cm
Rewind mode	70 to 130 gm-cm

In case specified take-up torque cannot be attained, Playback mode: replace whole tension arm block comp.

Fast Forward or Rewind mode: replace idler A comp.

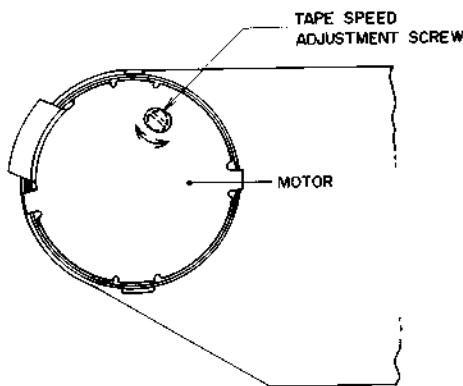

Fig. 24 Tape Speed Adjustment

2. TAPE SPEED ADJUSTMENT (Refer to Fig. 24)

Playback a 1,000 Hz pre-recorded test tape and adjust tape speed adjustment screw to obtain a tape speed of 1,000 Hz $\pm 1\%$.

3. PINCH ROLLER PRESSURE MEASUREMENT (Refer to Fig. 25)

At playback mode, pull back the pinch roller with a spring gauge until the pinch roller separates from the capstan by about 1 mm to 2 mm and then gently return. Take a reading of the spring gauge indication at the moment the pinch roller touches the capstan and begins to rotate.

Specified Pinch Roller Pressure: $350 \pm 50 \text{ gm}$

In case specified pressure cannot be attained, replace the pinch roller spring.

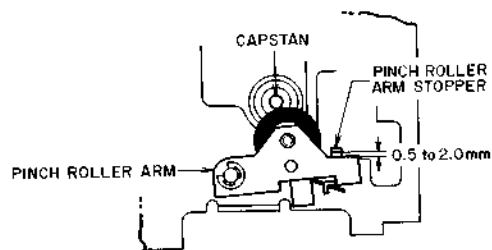

Fig. 26 Gap Between Pinch Roller Arm and Stopper

4. ADJUSTMENT OF GAP BETWEEN THE PINCH ROLLER ARM AND STOPPER (Refer to Fig. 26)

Adjust by bending the pinch roller stopper so that a 0.5 to 2.0 mm gap is definitely obtained between the pinch roller arm and the pinch roller arm stopper when the machine is set to playback mode.

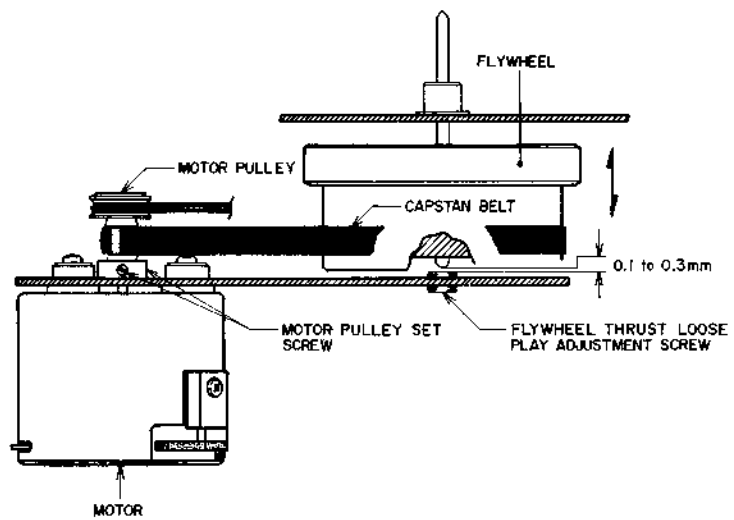

Fig. 27 Flywheel Thrust Loose Play Adjustment

5. FLYWHEEL THRUST LOOSE PLAY ADJUSTMENT (Refer to Fig. 27)

Adjust by turning flywheel thrust loose play adjustment screw to obtain a 0.1 to 0.3 mm of loose play when the flywheel is moved as indicated by the arrow mark. Paint lock the adjustment screw.

X. CASSETTE RECORDER HEAD ADJUSTMENT

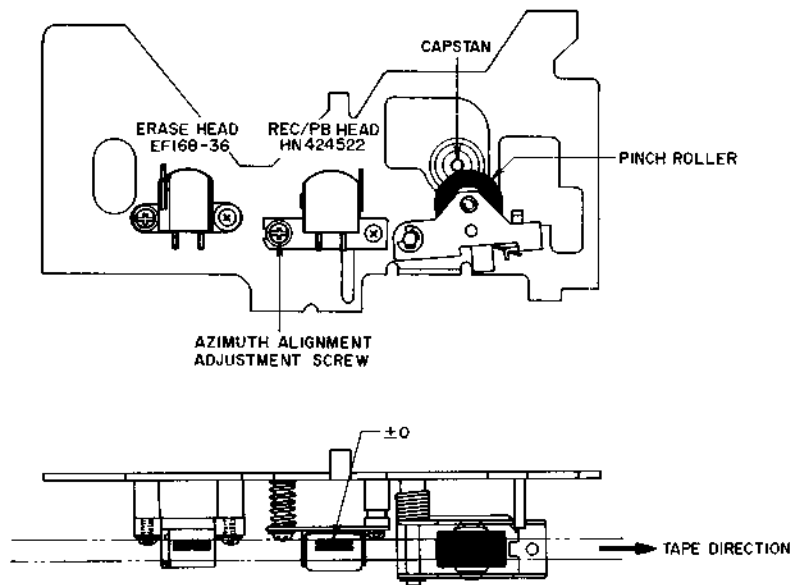

Fig. 28

RECORDING/PLAYBACK HEAD AZIMUTH ALIGNMENT ADJUSTMENT (Refer to Fig. 28)

Playback a 10 kHz Azimuth Adjustment Test Tape and adjust Rec/PB Head Azimuth Adjustment Screw to obtain maximum output.

At this time connect an oscilloscope to the line output and confirm that the left and right output waveforms are in-phase.

If not in-phase, because the azimuth adjustment has not been made to optimum point, repeat adjustment.

NOTES: 1. Be sure to clean the heads prior to adjustment.

2. As the use of a magnetized driver or other magnetized tools in the vicinity of the heads will cause the heads to become magnetized, use only demagnetized tools for head adjustment.

XI. CASSETTE RECORDER AMPLIFIER ADJUSTMENT

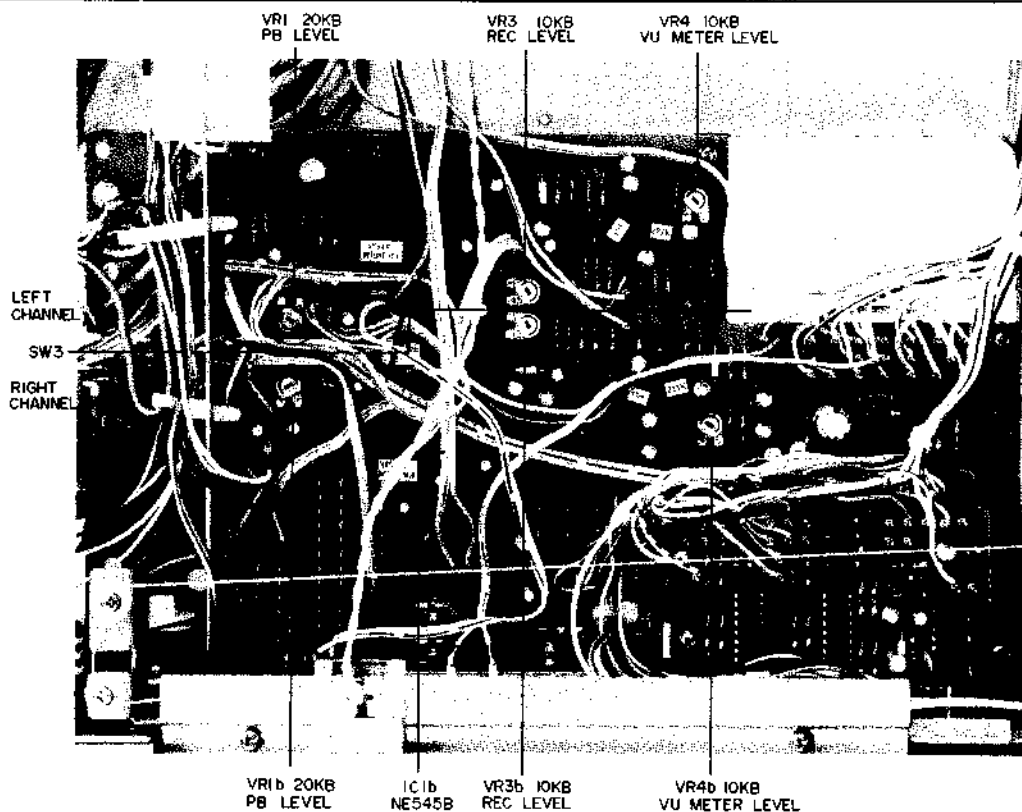

Fig. 29 Cassette Recorder Adjustment

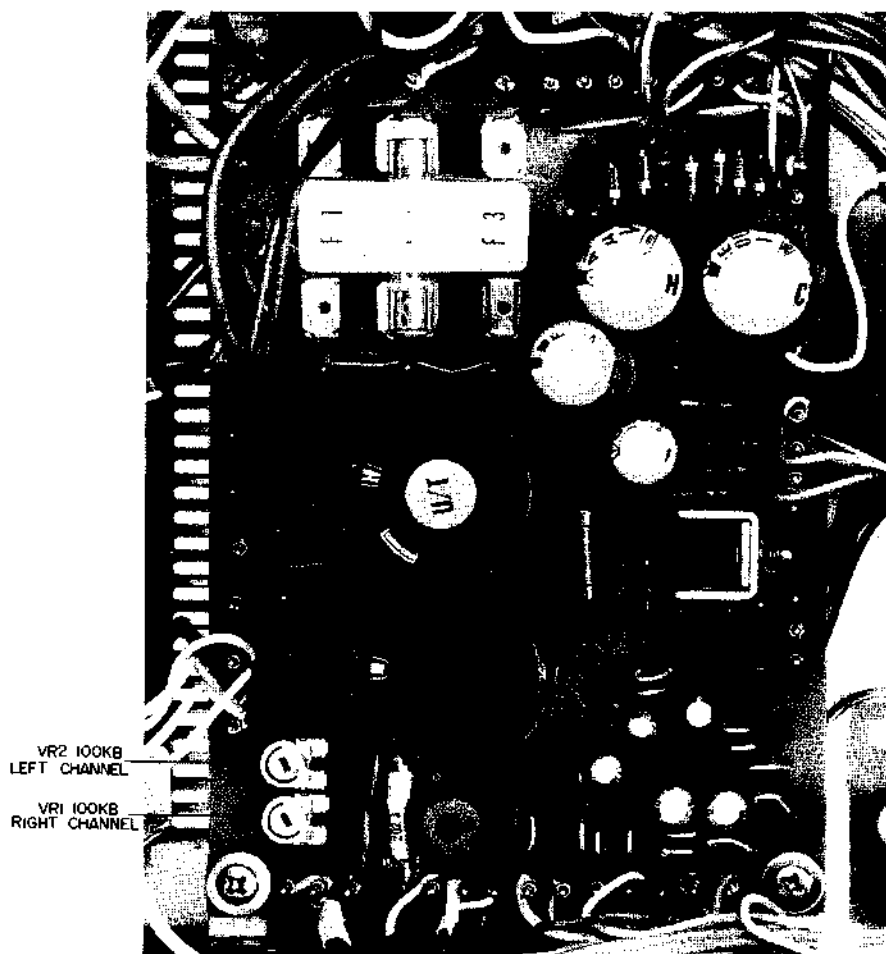

Fig. 30 Cassette Recorder Adjustment

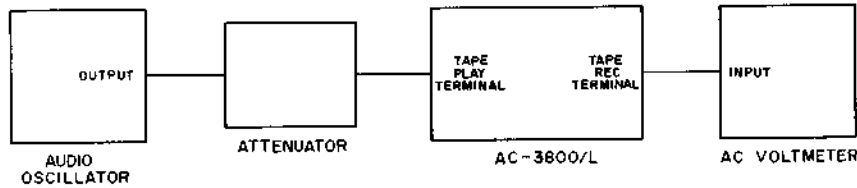

Fig. 31 Measuring Instrument Connection

Step	Adjustment Item	Test Tape, Supply Signal	Mode	Adjustment Point	Result	Remarks
1	Playback Level Adjustment	333 Hz, 0 VU Test Tape	PLAY	VR1, 20 k Ω	-14 ± 0.5 dB (150 mV)	
2	VU Meter Sensitivity Adjustment	333 Hz, 0 VU Test Tape	PLAY	VR4, 10 k Ω	0 VU indication	
3	Recording Level Adjustment	Low Noise Blank Tape, 1,000 Hz, 0 VU recording	REC/PLAY	VR3, 10 k Ω	-14 ± 0.5 dB (150 mV)	Refer to Note 5
4	Frequency Response Adjustment	Low Noise Blank Tape, 1,000 Hz, 10,000 Hz, -20 VU recording	REC/PLAY	VR1, 100 k Ω (RIGHT Channel) VR2, 100 k Ω (LEFT Channel)	1,000 Hz to 10,000 Hz flat response	Refer to Note 5

Chart 4

NOTES:

1. Connect measuring instruments as shown in Fig. 31.
2. Set Tape Selector to Low Noise.
3. Set Dolby N.R. Switch to OFF.
4. Set Monitor Switch to TAPE.
5. After Recording Level and Frequency Response Adjustments have been made with Low Noise Tape, confirm with Chrome.
6. Because each of these adjustments are vital to perfect Dolby N.R. circuit operation, be sure that they are carried out with as little error as possible.
7. Use the following cassette measuring tape:
 - Low Noise Tape: Fuji C-60LN
 - Chrome Tape: TDK SA C-60

XII. TURN TABLE SECTION ADJUSTMENT

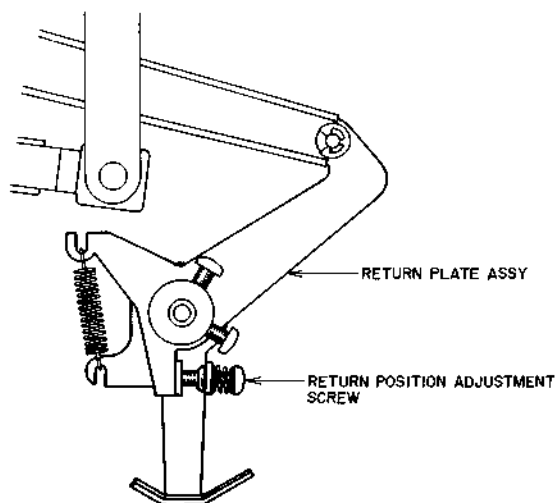

Fig. 32

1. RETURN POSITION ADJUSTMENT

As shown in Fig. 32, when the adjustment screw is turned to the right, the return position is slowed (inside circumference approach) and when the adjustment screw is turned to the left, the return position is speeded up (outside circumference approach).

- * When the adjustment screw is turned one revolution, the position of the PU Arm stylus tip is changed by about 8.5 mm)
- * Always confirm this adjustment with 30 cm LP record.

Also with turntable removed, confirm that the AUTO-CLUTCH begins to move out when the PU Arm stylus tip is 65.5 mm to 59 mm from the turntable shaft center.

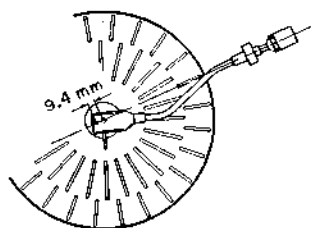

Fig. 33

OVERHANG ADJUSTMENT

The overhang is determined by the distance between the stylus and turntable spindle when the tone Arm is moved to the center of the turntable.

Correct overhang for the AC-3800/L is 9.4 mm.

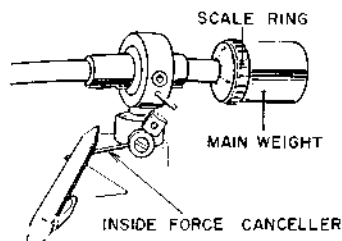

Fig. 34

3. STYLUS PRESSURE ADJUSTMENT

- 1) Remove stylus guard and lift tone arm off arm rest.
- 2) Slide tone arm lifter lever toward you.
- 3) Temporarily hold down inside force canceller with a pen or similar object and move tone arm toward record.
- 4) Adjust main weight by turning it left or right so that tone arm becomes horizontal with turntable.
- 5) Adjust stylus pressure ring to "0" setting with marker, turn both main weight and stylus pressure scale ring to the 2.0 g recommended stylus pressure setting.
- 6) Remove object to release inside force canceller and permit operation.

XIII. DC RESISTANCE OF VARIOUS COILS

Part	Designation	DC Resistance
Recording/Playback Head	HN424522	160 ohms
Erase Head	EF168-36	4.7 ohms
Plunger Solenoid	P-14W	4.7 ohms

Chart 5

XIV. CLASSIFICATION OF VARIOUS P.C BOARDS

1. RELATION OF P.C BOARD TITLE AND IDENTIFICATION NUMBER

P.C Board	Number of P.C Board
Tone Control, Rec/PB Amp P.C Board	AC-3501A
LED P.C Board	AC-3501B
Lamp P.C Board (A)	AC-3501C
Lamp P.C Board (B)	AC-3501D
Headphone P.C Board	AC-3501E
Beat Switch P.C Board	AC-3501F
Multi Function P.C Board	AC-3801A
Power Supply, Sys. Con and OSC P.C Board	AC-3503
Main Amp P.C Board	AC-3504
Touch SW P.C Board	AC-3802
IC P.C Board	AC-3803
Volume P.C Board	AC-3804
Vari Con P.C Board	AC-3801B
Mute Switch P.C Board	T4-8938

Chart 6

2. COMPOSITION OF VARIOUS P.C BOARDS
 1) TONE CONTROL, REC/PB AMP P.C BOARD AC-3501A

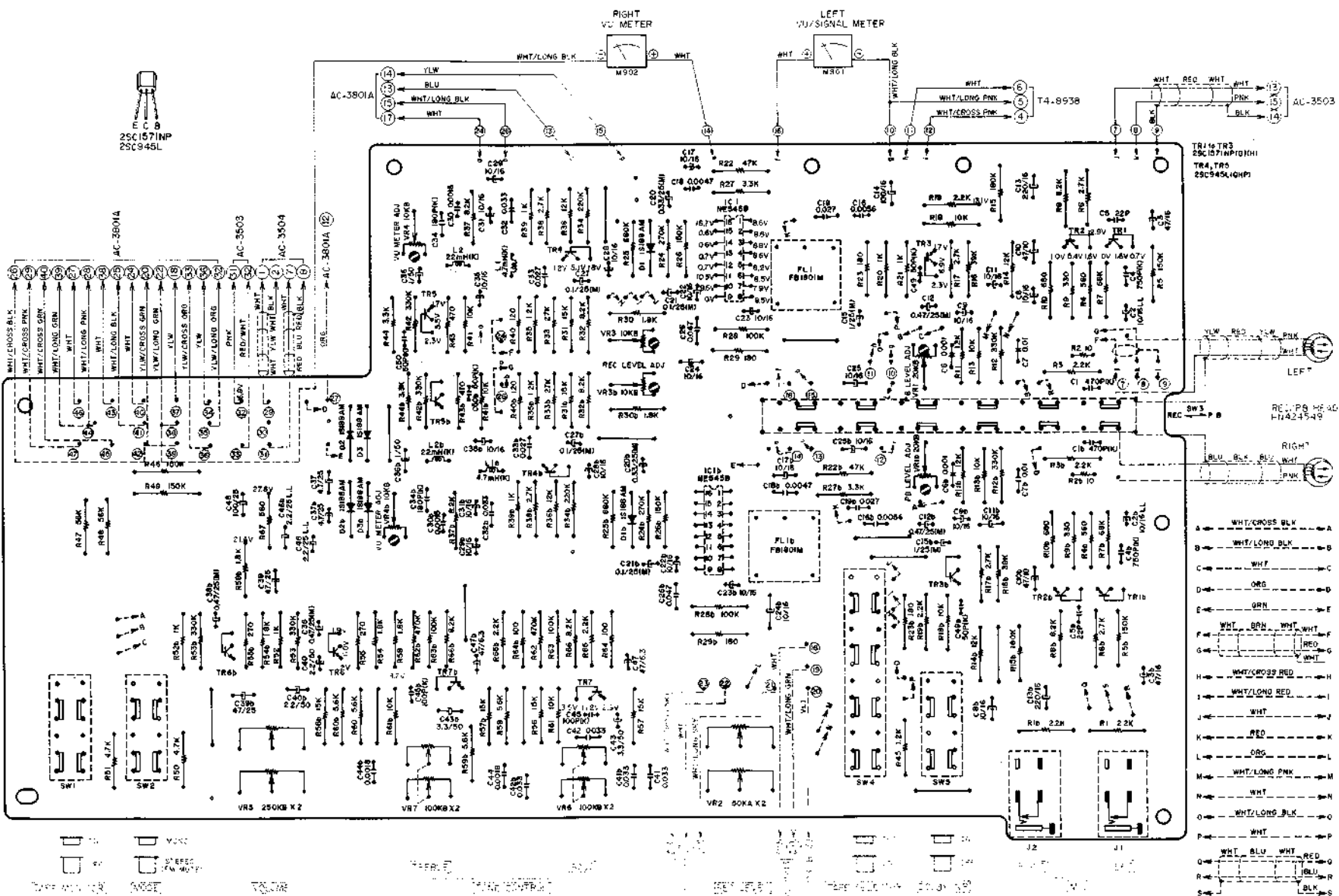

25C1571NP
 25C945L

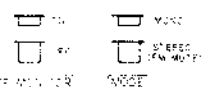

2) LED P.C BOARD AC-3501B

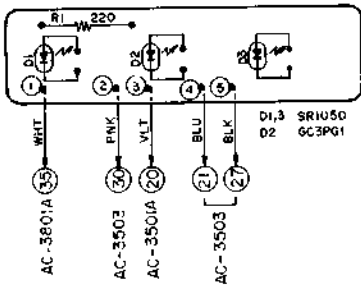

3) LAMP P.C BOARD (B/A) AC-3501C/D

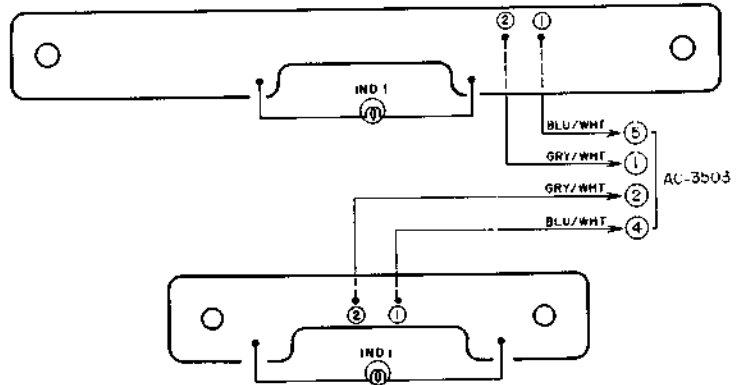

4) HEADPHONE P.C BOARD AC-3501E

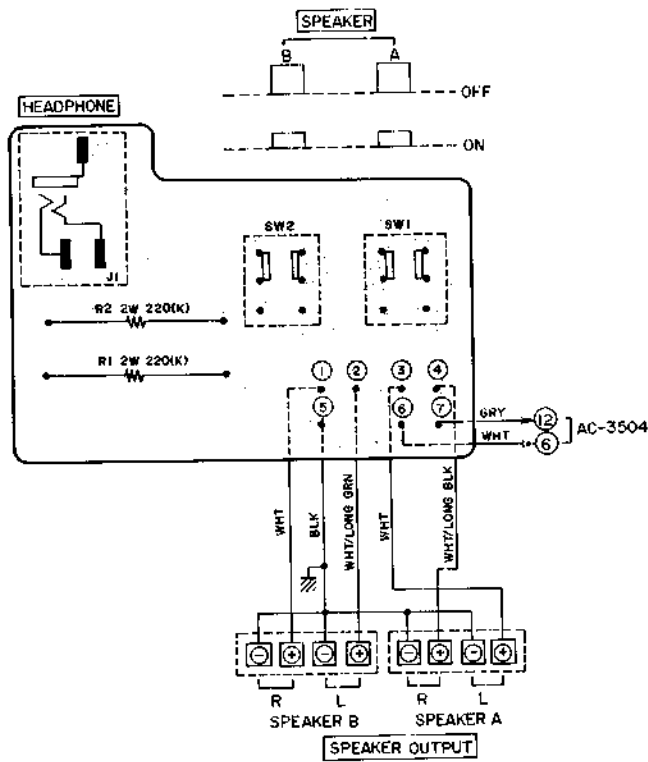

5) BEAT SWITCH P.C BOARD AC-3501F

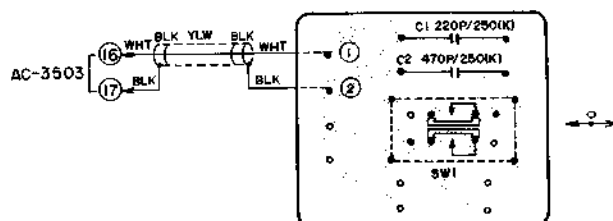

6) POWER, SYS. CON AND OSC P.C BOARD AC-3503 (U/T)

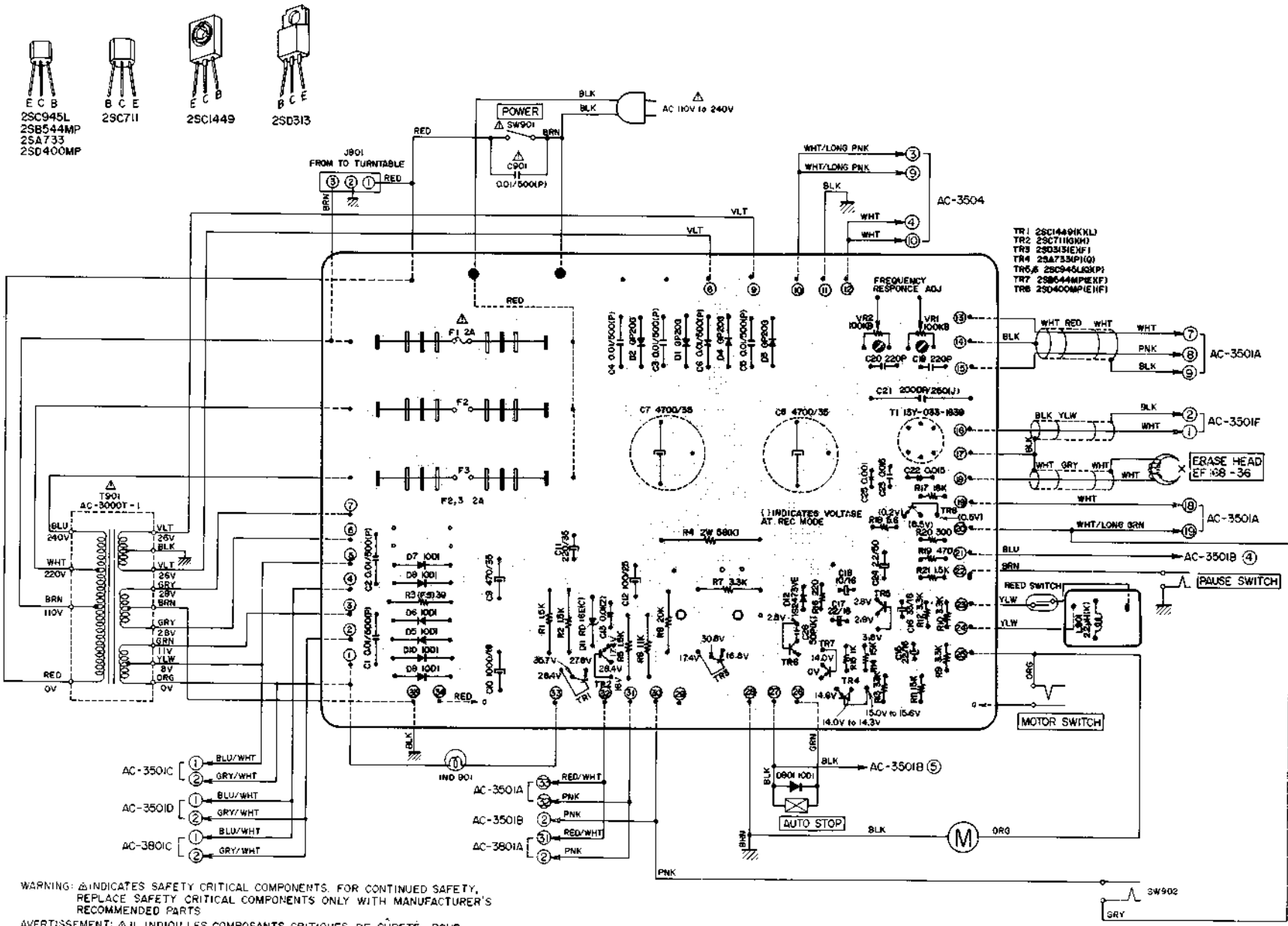

7) POWER, SYS. CON AND OSC P.C BOARD AC-3503 (CEF, BEAB)

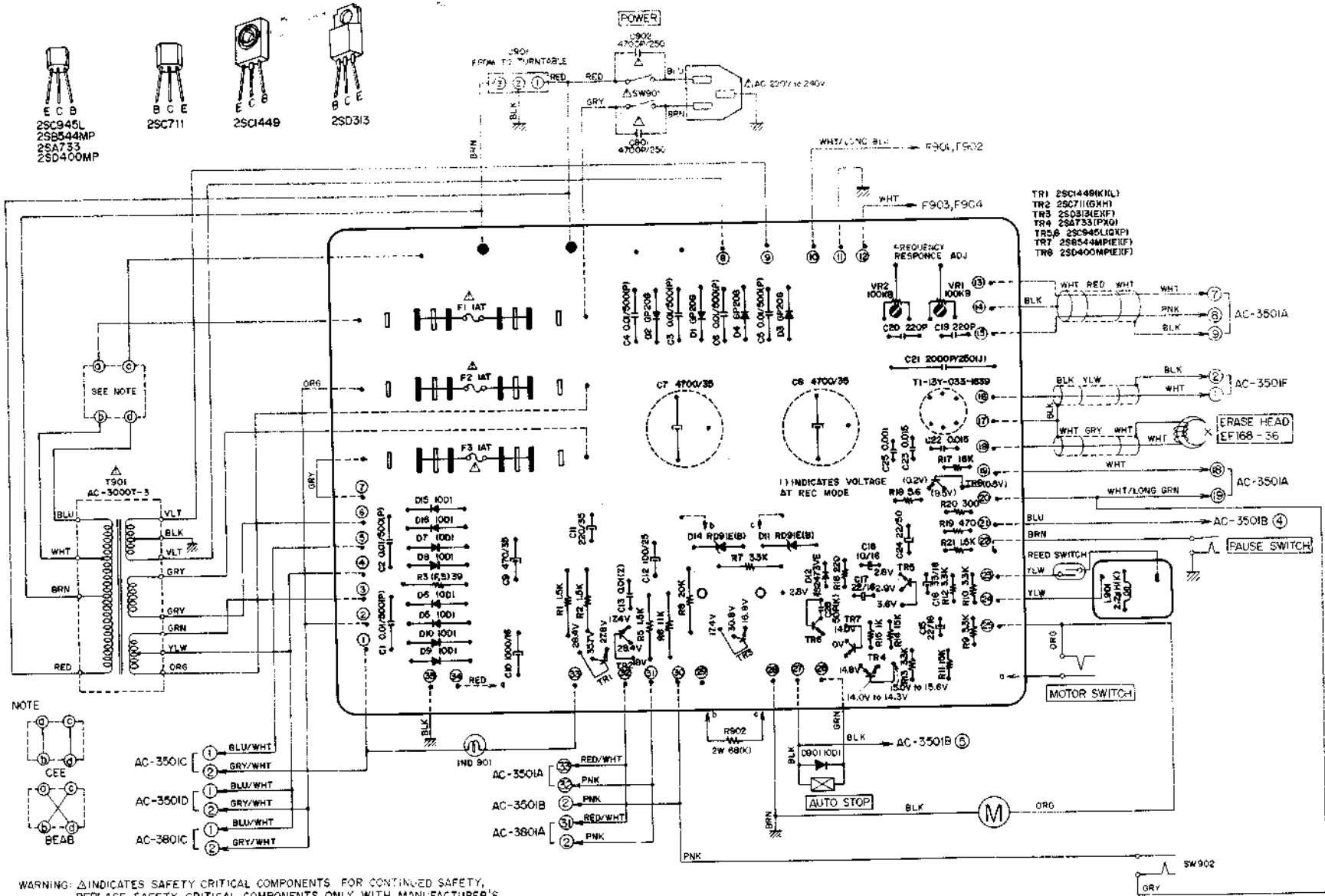

8) POWER, SYS. CON AND OSC P.C BOARD AC-3503 (CSA)

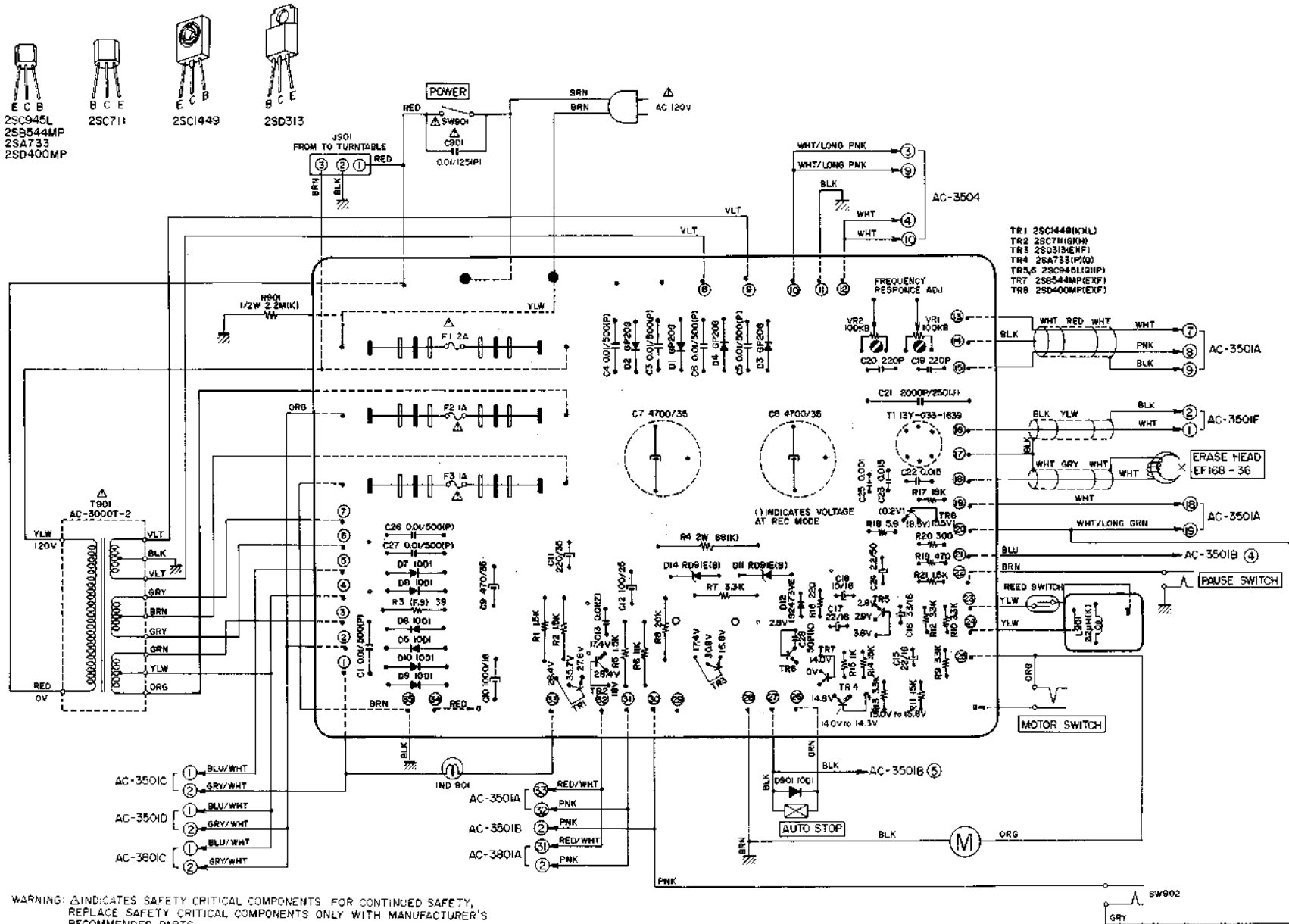

9) MAIN AMP P.C BOARD AC-3504 (U/T, CSA)

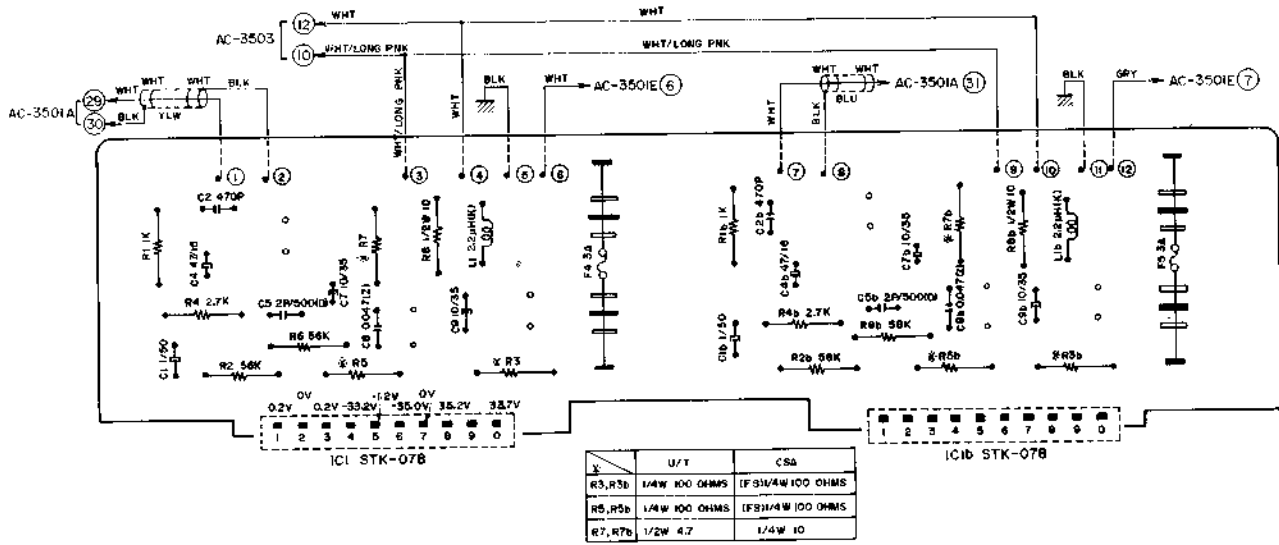

10) MAIN AMP P.C BOARD AC-3504 (CEE, BEAB)

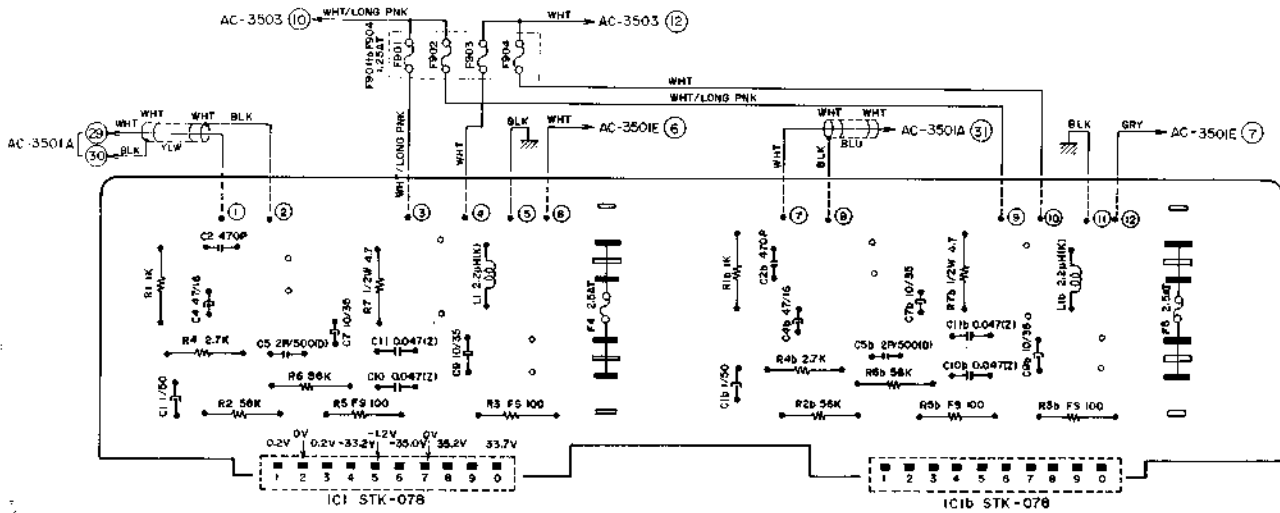

11) MULTI FUNCTION P.C BOARD AC-3801A AND VARI. CON P.C BOARD AC-3801B AC-3800

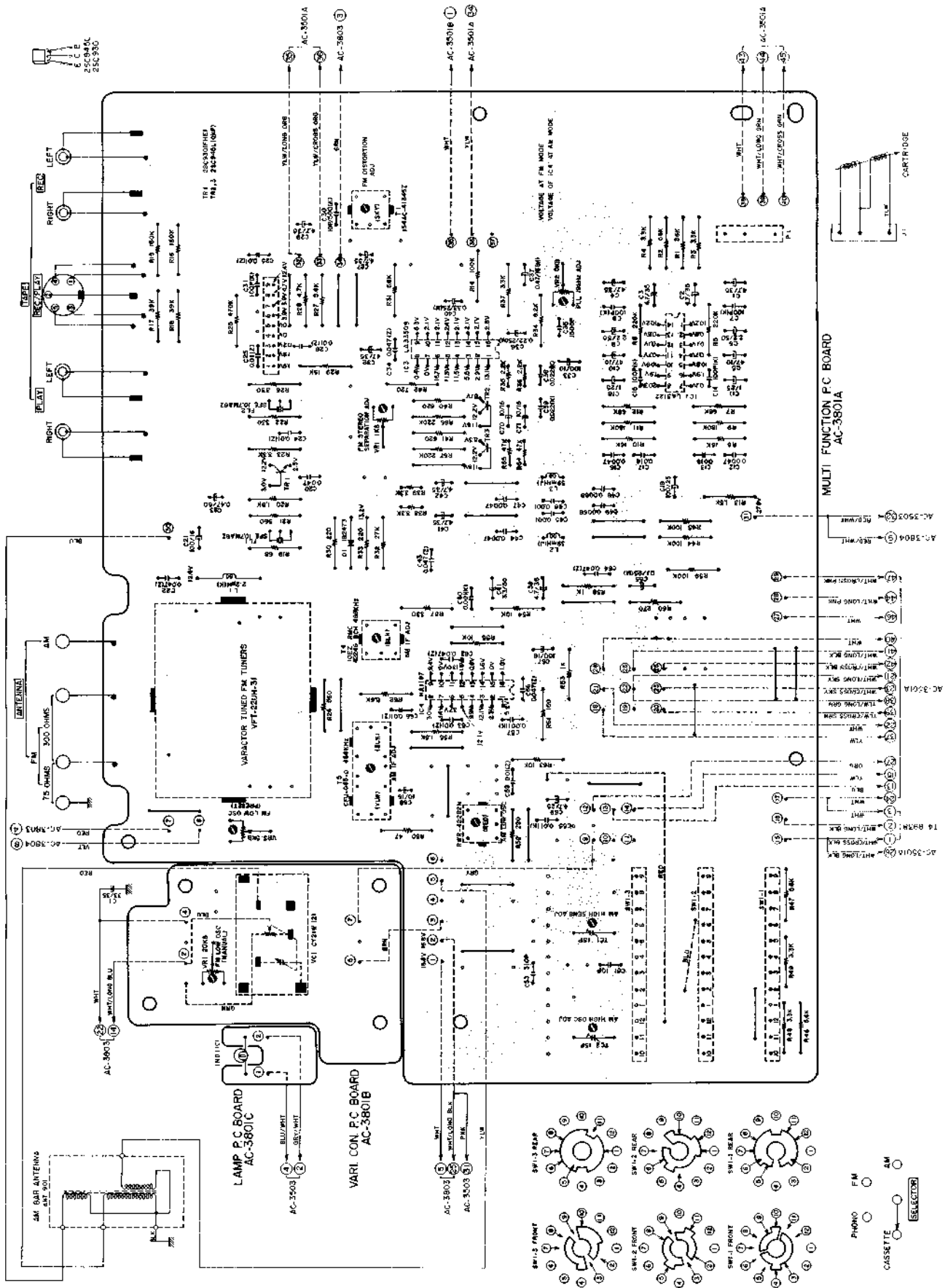

12) MULTI FUNCTION P.C BOARD AC-3801A AND VARI. CON P.C BOARD AC-3801B AC-3800L

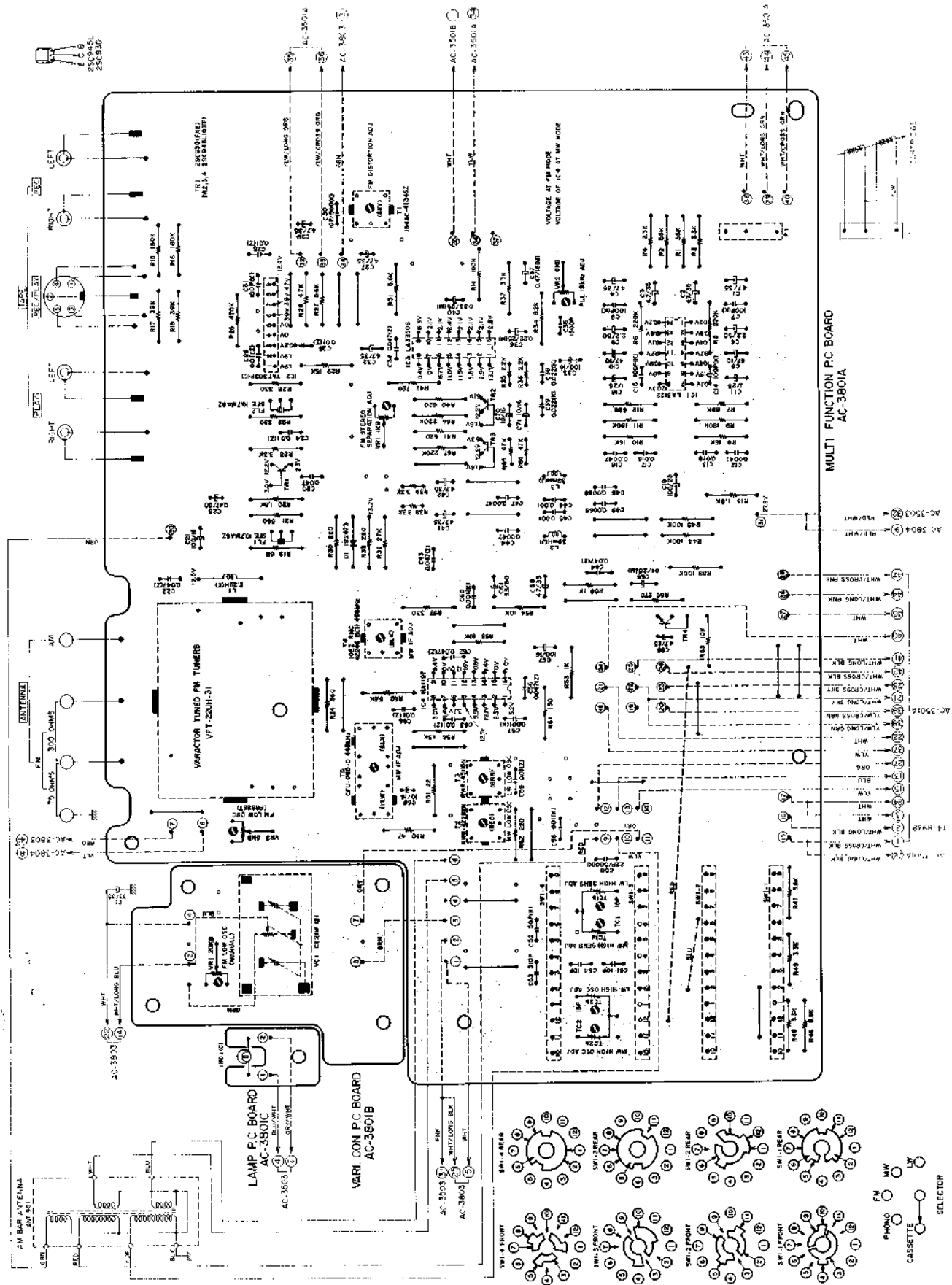

13) TOUCH SWITCH P.C BOARD AC-3802

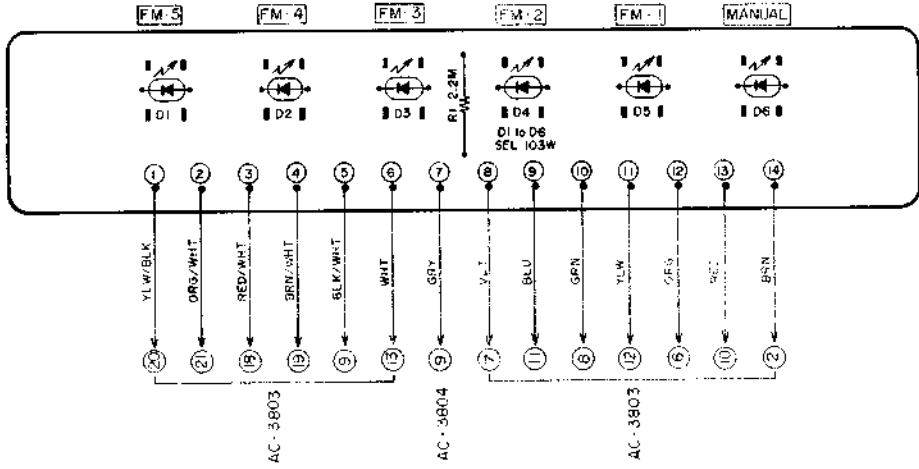

14) IC P.C BOARD AC-3803

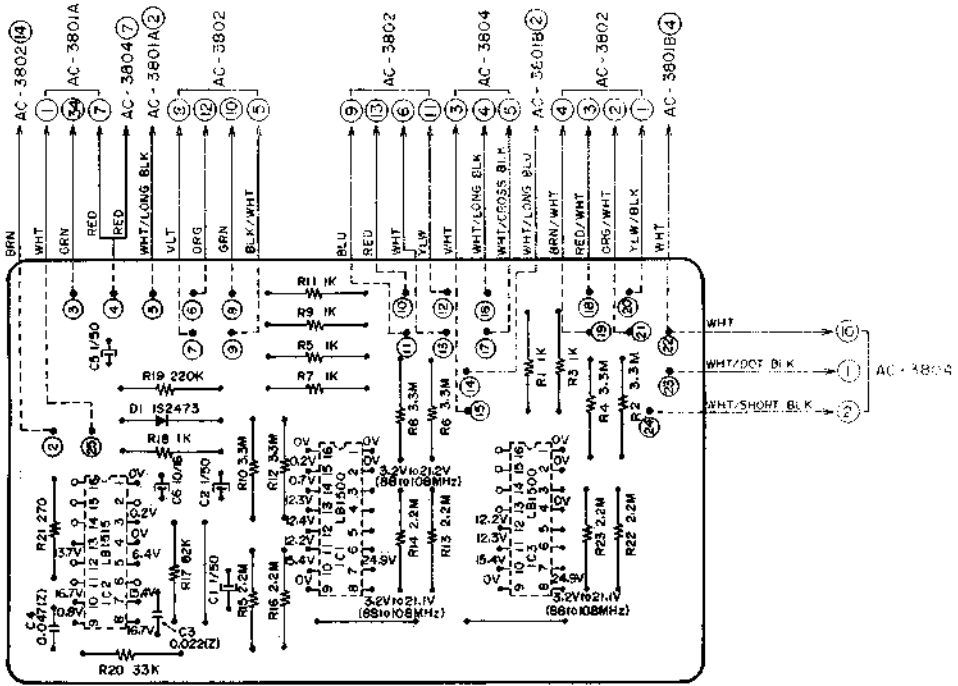

15) VOLUME P.C BOARD AC-3804

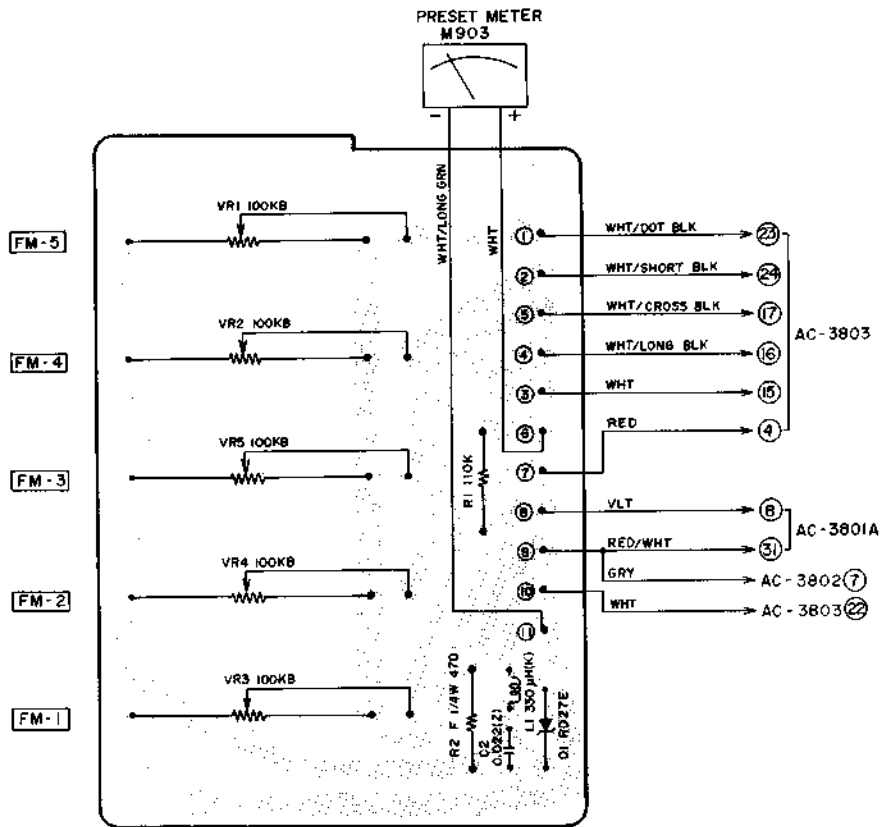

16) MUTE SWITCH P.C BOARD T4-8938

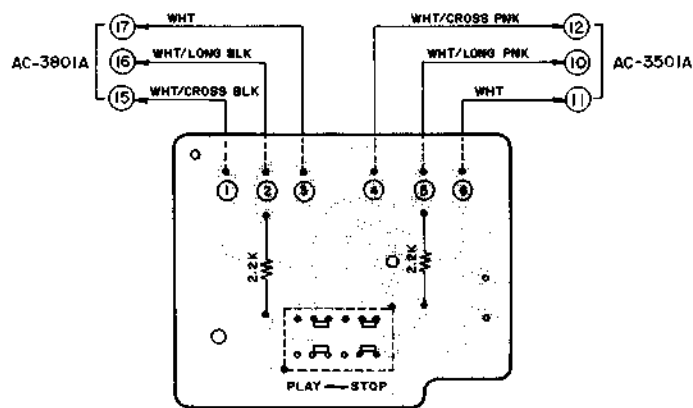

HOW TO USE THIS PARTS LIST

1. This parts list is compiled by various individual blocks based on assembly process.
2. When ordering parts, please describe parts number, serial number, and model number in detail.
3. How to read List

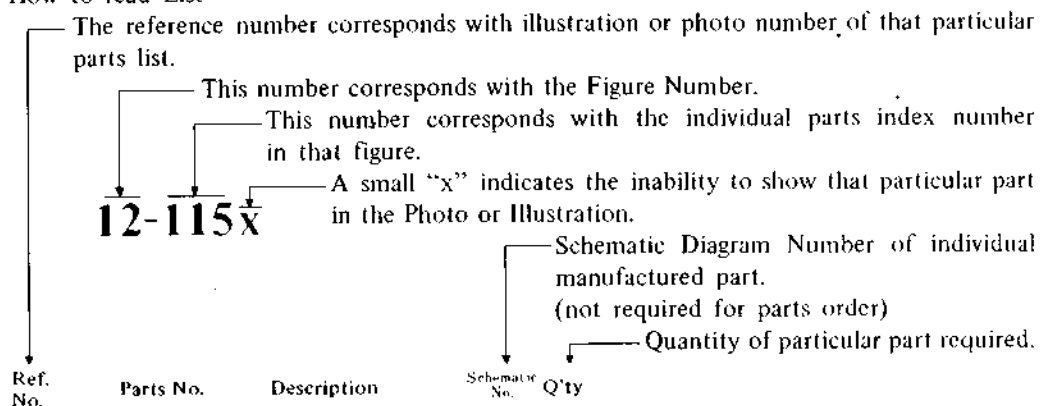

Ref. No.	Parts No.	Description	Schematic No.	Qty
FLYWHEEL BLOCK #13				
12-115x	800425	Flywheel Block Assy. Comp.	RDG #13	1
12-116	244506	Flywheel Only	RD-233	1
12-117x	244754	Felt, Flywheel	RD-275	1
12-118	251324	Main Metal Case	RD-236	1
12-119	253080	Main Metal	RD-237	1

4. The symbol numbers shown on the P.C. Board list can be matched with the Composite Views of Components of the Schematic Diagram or Service Manual.
5. Please utilize separate "Common List for Service Parts" for Resistor Parts orders.
6. The shape of the parts and parts name, etc. can be confirmed by comparing them with the parts shown on the Electrical Parts Table of P.C. Board.
7. Both the kind of part and installation position can be determined by the Parts Number. To determine where a parts number is listed, utilize Parts Index at end of Parts List.
It is necessary first of all to find the Parts Number. This can be accomplished by using the Reference Number listed at right of parts number in the Parts Index. (meaning of ref. no. outlined in Item 3 above).
8. Utilize separate "Price List for Parts" to determine unit price. The most simple method of finding parts Price is to utilize the reference number.

- CAUTION:**
1. When placing an order for parts, be sure to list the parts no., model no., and description. There are instances in which if any of this information is omitted, parts cannot be shipped or the wrong parts will be delivered.
 2. Please be careful not to make a mistake in the parts no. If the parts no. is in error, a part different from the one ordered may be delivered.
 3. Because parts number and parts unit supply in the Preliminary Service Manual (Basic Parts List) may be partially changed, please use this parts list for all future reference.

WARNING: \triangle INDICATES SAFETY CRITICAL COMPONENTS. FOR CONTINUED SAFETY, REPLACE SAFETY CRITICAL COMPONENTS ONLY WITH MANUFACTURER'S RECOMMENDED PARTS.

AVERTISSEMENT: \triangle IL INDIQU LES COMPOSANTS CRITIQUES DE SURETE. POUR MAINTENIR LE DEGRE DE SECURITE DE L'APPAREIL NE REMPLACER LES COMPOSANTS DONT LE FONCTIONNEMENT EST CRITIQUE POUR LA SECURITE QUE PAR DES PIECES RECOMMANDEES PAR LE FABRICANT.

AC INLET SYSTEM

This model is equipped with an AC INLET SYSTEM. Please refer to the AC INLET SYSTEM CHART below for the specific type. By the AC INLET SYSTEM, AC (mains) cord can be connected to and disconnected from the model because the model is provided with socket exclusively for AC (mains) cord on its main body.

Please note, however, that certain models are not equipped with this system and has a built-in AC (mains) cord as before.

AC INLET SYSTEM CHART

CLASS I

CLASS II

Ⓜ This mark indicating double insulation will be attached to machine's rear panel

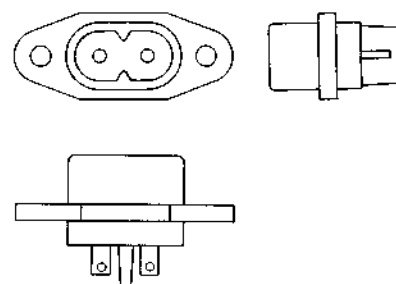
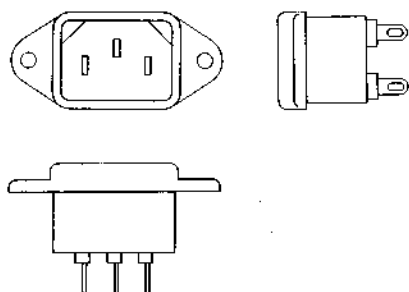

Picture 1
AC INLET
to be
installed
on machines

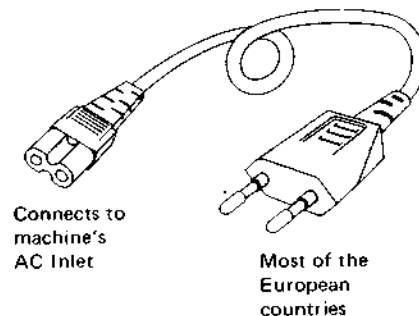
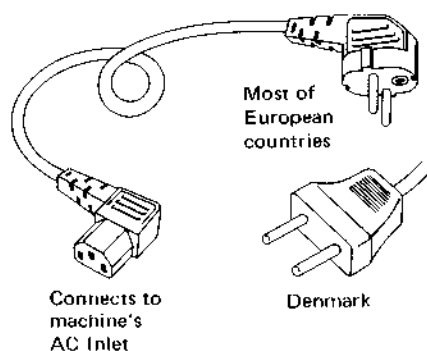

Picture 2
AC (mains)
cord

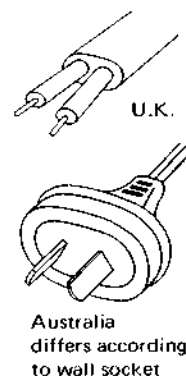
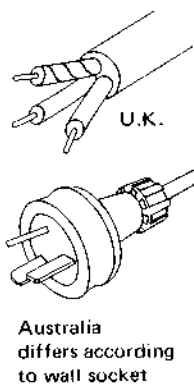

Parts List for AC (mains) Cord Set

Standard		Description	Type of AC Inlet	Parts No.
Class I	CEE	Cord Set CEE (3 cores)	3P	EW302993
	BEAB	Cord Set BEAB (3 cores)	3P	EW302994
	SAA	Cord Set SAA (3 cores)	3P	EW302996
	U/T	Cord Set U/T (3 cores)	3P	EW302646
Class II	CEE	Cord Set CEE (2 cores)	2P	EW638144
	BEAB	Cord Set BEAB (2 cores)	2P	EW302995
	SAA	Cord Set SAA (2 cores)	2P	EW302991
	U/T	Cord Set U/T (2 cores)	2P	EW302899

1. RECOMMENDED SPARE PARTS LIST

Because, if the parts listed below are on hand, almost any repair can be accomplished, we suggest that you stock these Recommended Spare Parts Items.

Parts No.	Description	Note
BA300364	Touch SW. P.C Board Comp. AC-3800	
BA301614	Touch SW. P.C Board Comp. AC-3800-BL	
BA300961	Power, Sys. Con & Osc P.C Board Comp.	U/T
BA300963	Power, Sys. Con & Osc P.C Board Comp.	CSA
BA300971	Power, Sys. Con & Osc P.C Board Comp.	CEE
BA290632	Tone Control & Rec/PB P.C Board Comp. AC-3500	
BA290654	Headphone P.C Board Comp. AC-3500	
BA300187	Vol. P.C Board Comp. AC-3800	
BA301615	Vol. P.C Board Comp. AC-3800-BL	
BA300702	Multi Function P.C Board Comp. AC-3800	
BA300703	Multi Function P.C Board Comp. AC-3800L	
BA301497	Main Amp P.C Board Comp.	U/T
BA301498	Main Amp P.C Board Comp.	CSA
BA301499	Main Amp P.C Board Comp.	CEE
BA300361	IC P.C Board Comp. AC-3800	
BA300358	Vari. Con P.C Board Comp. AC-3800	
BT698804	△ Power Trans. AC-3000T-1	U/T T901
BT304318	△ Power Trans. AC-3000T-4	CSA T901
BT294131	△ Power Trans. AC-3000T-3	CEE, BEAB T901
ED300184	Zener Diode RD-27E (Special)	D1 (AC-3804)
ED290722	Zener Diode RD-16E (C)	U/T D11 (AC-3503)
ED300269	Zener Diode RD-9-1E (B)	CSA, CEE D11, D14 (AC-3503)
ED562386	Germanium Diode 1S188AM	D1 to 3 (AC-3501A)
ED245417	Silicon Diode GP20G	D1 to 4 (AC-3503)
ED224526	Silicon Diode 10D1	D5 to 10 (AC-3503)
ED624903	Silicon Diode 1S2473	D1 (AC-3801A)
ED653624	LED SEL-103W	D1 to 5 (AC-3802)
ED283138	LED GL-3PG1	D2 (AC-3501B)
ED698826	LED SR-105D	D1, 3 (AC-3501B)
EE300785	Varactor Tuner VFT-22UH-31	(AC-3801A)
EI303086	IC LBI500	IC1, 3 (AC-3803)
EI300182	IC LBI515	IC2 (AC-3803)
EI697871	IC LA-3122S	IC1 (AC-3801A)
EI299441	IC TA7303P (C)	IC2 (AC-3801A)
EI650597	IC LA-3350S	IC3 (AC-3801A)
EI299700	IC HA1197	IC4 (AC-3801A)
EI605013	IC NE545B	IC1 (AC-3501A)
EI299608	IC STK-078	IC1 (AC-3504)
EM300759	Pre-Set Tuning Meter KL-218D-107	AC-3800/L M903

Parts No.	Description	Note
EM301315	Pre-Set Tuning Meter KL-218D-108	AC-3800BL/L-BL M903
EM698815	VU Meter KL-218D-104	AC-3800/L M901, 902
EM301306	VU Meter KL-218D-106	AC-3800BL/L-BL M901, 902
EO293387	Osc Coil RWR-42282N	T2 (AC-3801A)
EO299564	Osc Coil LW RWR-43115N	T3 AC-3800L (AC-3801A)
EO290744	Osc Coil 13Y-033-1639	(AC-3503)
ES224436	△ Push SW. JP01	U/T SW901
ES239218	△ Push SW. JP01 (TV-4)	CSA SW901
ES242346	△ Push SW. JP17	CEE, BEAB SW901
ES299362	Slide SW. CL212E	SW3 (AC-3501A)
ET618873	Transistor 2SC930 (E) (F)	
ET639437	Transistor 2SC945L (Q) (P)	
ET554657	Transistor 2SA733 (P) (Q)	TR4 (AC-3503)
ET223446	Transistor 2SC1571NP (G) (H)	(AC-3501A)
ET649034	Transistor 2SC1449 (K) (L)	TR1 (AC-3503)
ET299507	Transistor 2SD400MP (E) (F)	TR8 (AC-3503)
ET299531	Transistor 2SB544MP (E) (F)	TR7 (AC-3503)
ET452531	Transistor 2SD313 (E) (F)	TR3 (AC-3503)
MB701111	Belt (Capstan) 62.25×5×0.4 CS-705D	
MB701122	Belt (Take-up) 1×56.7 CS-705D	
MB719008	Belt AP-003	

2. ILLUSTRATION OF MECHA BLOCK

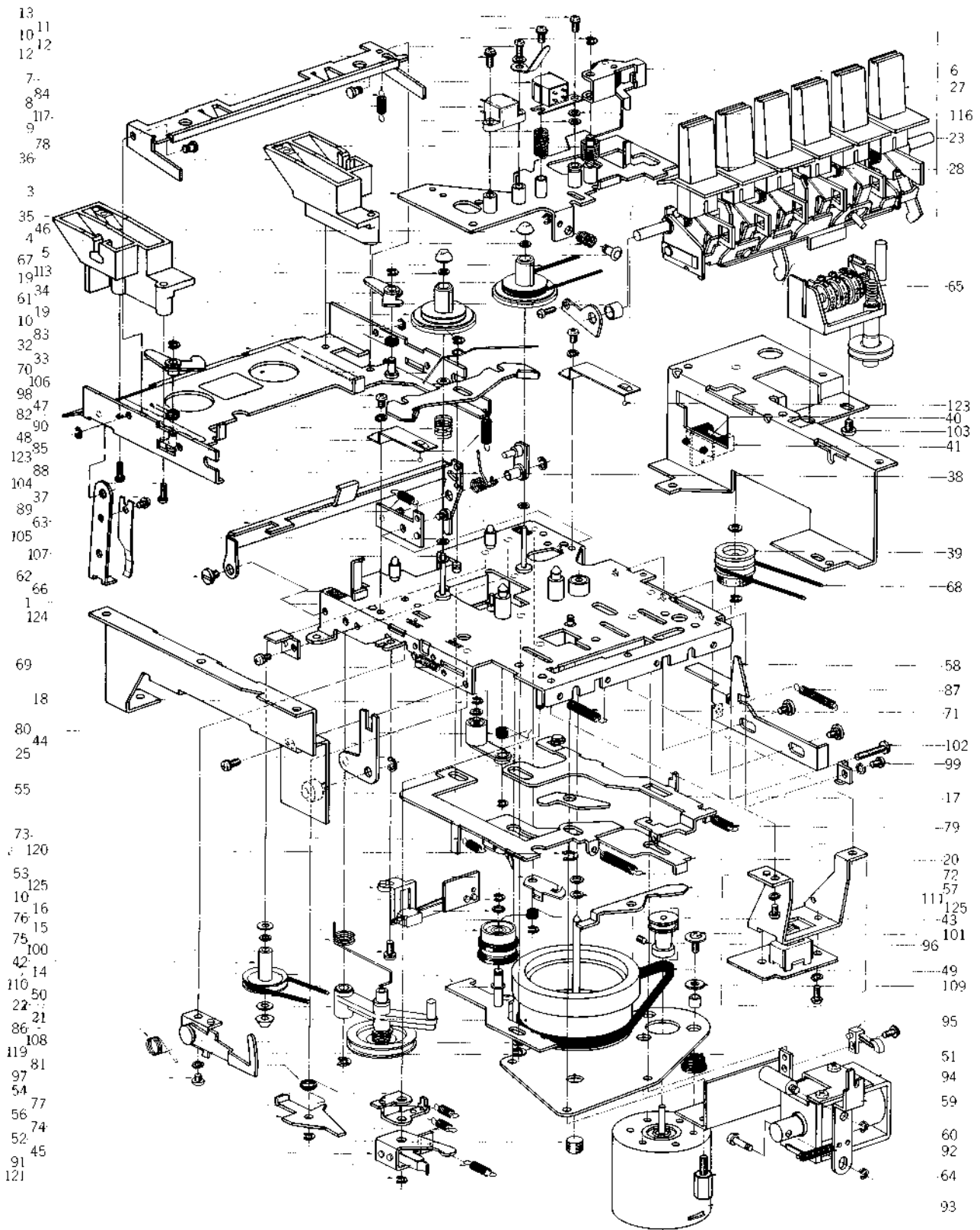

2) MECHA BLOCK

Ref. No.	Parts No.	Description	Schematic No.	Ref. No.	Parts No.	Description	Schematic No.
2-1	BZ720955	Mecha Frame Comp. CS-705D	TA2-1387	2-52	ZS721620	Flywheel Adjust. Screw	
2-2x	BH720966	Head Base Block Comp.				CS-705D	T4 7869
		CS-705D	TA3-1624	2-53	MZ721631	Pause Lock Plate CS-705D	T4-10218
2-3	HZ723060	Head Base Comp. CS-707D	TA3-1425	2-54	ML721642	RWD Lever B CS-705D	T4 9314
2-4	ZG720988	Head Base Shaft Spring		2-55	ML721653	Brake Function Lever CS-705D	T3 702
		CS-705D	T4 10180	2-56	ML740392	REC Lever B-6 AC-3500/L/BL	T4 14573
2-5	MS720990	Head Base Shaft CS-705D	T4 10436	2-57	ML721675	FF Lever CS-705D	T4-10586
2-6	BZ721001	Pinch Roller Arm Comp.		2-58	ML721686	Hook Lever CS-705D	T4 11844
		CS-705D	TA4-13682	2-59	ML721708	Shut Off Lever CS-705D	T4-11846
2-7	HP721045	REC/PB HEAD	T4 18242 / 18244	2-60	MS721710	Plunger Shaft CS-705D	T4 11847
		(HN-424549/424522)CS-707D		2-61	TC721721	Spacer CS-705D	T4-11848
2-8	HE721056	ERASE HEAD (168-36)		2-62	ZS721732	Graduated Screw M2.6	
		CS-705D	T4-8807			CS-705D	T4-11849
2-9	ZG717827	Head Adjust Spring CT-5	T4-5067	2-63	ML721743	Timing Lever CS-705D	T3 1334
2-10	ZW358018	'E' Ring 2M	6-19	2-64	ZS721765	Screw, hexagon head M2.6	
2-11	ZS722081	Screw, pan head w/s. washer				CS-705D	T4 12082
		M2x5 CS-705D	Z4-5077	2-65	MC701368	Counter CS-705D	T4 13188
2-12	ZS608106	Screw, pan head 2x6	Z4 2365	2-66	MB721798	Rubber Cushion CS-705D	T4 12056
2-13	ZS721091	Screw, pan head w/washer		2-67	MB701370	Belt A (Counter) CS-705D	T4 13166
		M2x5 CS-705D	Z4 5551	2-68	MB701381	Belt B (Counter) CS-705D	T4 13167
2-14	BL721113	FR Lever Comp. CS-705D	TA4-7049	2-69	ZG721855	REC Safety Plate Spring	
2-15	BZ721124	Idler A Comp. CS-705D	TA4-12545			CS-705D	T4 7147
2-16	ZW721135	Flat Washer M25x0.1 CS-705D	Z4-5137	2-70	ZG721866	Brake Lever Spring CS-705D	T4-5126
2-17	BZ721146	Pause Function Lever Comp.		2-71	ZG721877	Head Base Spring CS-705D	T4 7076
		CS-705D	TA4-12525	2-72	ZG721888	Brake Function Lever Spring	
2-18	BZ721157	Idler B Comp. CS-705D	TA4-9511			CS-705D	T4 7077
2-19	BR700986	Supply, Take-up Reel Table		2-73	ZG721890	FF Lever Spring CS-705D	T4 7079
		Block Comp. CS-705D	TA4-7102	2-74	ZG721901	REW Lever Spring B CS-705D	T4 10401
2-20	ML723082	FF Lever Comp. CS-707D	TA4-13659	2-75	ZG721912	Idler B Lever Spring CS-705D	T4 12624
2-21	BF701100	Flywheel w/shaft CS-705D	TA4 12528	2-76	ZG740393	Pause Lock Plate Spring	
2-22	BL720347	Tension Arm B Block Comp.				AC-3500/L/BL	T4-14033
		CS-707D	TA4-13681	2-77	ZG721934	FR Lever Spring D CS-705D	T4 7846
2-23	BK700301	Operation Button Block Comp.	TA2 1388	2-78	ZG721102	Pinch Roller Spring CS-705D	T4 10359
2-24x	BK740391	Operation Button Block Comp. (BL)	TA2 1537	2-79	ZG721945	Pause Function Lever Spring	
			6-19			CS-705D	T4 10360
2-25	ZW270101	'E' Ring 3M		2-80	ZG721956	Idler B Lever Spring CS-705D	T4 7853
2-26x	ZS460440	Screw, pan head 2x4		2-81	ZG721967	REC Lever Spring B CS-705D	T4 7082
2-27	SB721247	Operation Button A CS-705D	T3 1530	2-82	ZG721361	Stop Lever Spring L CS-705D	T4 11816
2-28	SB721258	Operation Button B (REC)		2-83	ZG721372	Stop Lever Spring R CS-705D	T4-11817
		CS-705D	T3 1531	2-84	ZG721383	Cassette Detector Arm Spring	
2-29x	SB743467	Operation Button A				CS-705D	T4-11818
		CS-705D-BL	T3-1709	2-85	ZG721978	Cassette Up Spring CS-705D	T4 11855
2-30x	SB743470	Operation Button B		2-86	ZG721980	Safety Lever Spring CS-705D	T4 11856
		CS-705D-BL	T3-1310	2-87	ZG723115	Hook Lever Spring CS-707D	T4 13653
2-31x	BZ700290	Cassette Holder Base Block Comp.	TA2-1389	2-88	ZG722002	Limiter Lever Spring CS-705D	T4-11858
2-32	BZ721260	Cassette Holder Base Comp.		2-89	ZG722013	Timing Lever Spring CS-705D	T4 13320
		CS-705D	TA3 1330	2-90	ZG722024	Back Tension Spring CS-705D	T4 5733
2-33	BL721282	Stop Lever L Comp. CS-705D	TA4-11810	2-91	ZG722035	Muting Lever Spring CS-705D	T4-13319
2-34	BL721293	Stop Lever R Comp. CS-705D	TA4-11813	2-92	ZG740394	Shut-off Lever Spring	
2-35	BZ721348	Cassette Guide L Comp.				AC-3500/L/BL	T4-15003
		(Lower) CS-705D	TA4-13183	2-93	BM701335	Motor Block Comp.	
2-36	BZ721350	Cassette Guide R Comp.				MHI-5R2CHA CS-705D	T4-8918
		(Lower) CS-705D	TA4-13184	2-94	EP740395	Plunger P-14W AC-3500/L/BL	T4 18147
2-37	ZS722092	Screw, pan head w/s. washer		2-95	ES722070	Leaf SW. H-7160 CS-705D	T4-8765
		M2x4 CS-705D	Z4 5074	2-96	ZS521943	Set Screw, hexagon socket 2x3	
2-38	BL721405	Limiter Lever Comp. CS-705D	TA4 11820			(CUP/P.)	Z4-2372
2-39	BZ721440	Counter Idler Comp. CS-705D	TA4-13185	2-97	ZS722103	Screw, pan head M2.6x3	
2-40	TC721473	SW. Installation Plate CS-705D	T4-11727			CS-705D	Z4-2400
2-41	ES721484	Reed SW. (MAH-16) CS-705D	T4 8351	2-98	ZS608185	Screw, pan head 2.6x4	Z4-2366
2-42	BZ721495	Idler Comp. CS-705D	TA4 12472	2-99	ZS722114	Screw, pan head w/s. washer	
2-43	MR740390	Motor Pulley Part				M2.6x4 CS-705D	Z4-5061
		AC-3500/L/BL	TA4-12527	2-100	ZS722125	Screw, pan head w/s. washer	
2-44	BL721517	Joint Lever Comp. CS-705D	TA4 13186			M2.6x6 CS-705D	Z4-5063
2-45	BL721528	Muting Lever Comp. CS-705D	TA4-13187	2-101	ZS740396	Screw, pan head M2.6x7	
2-46	MT721530	Reel Shaft Cap CS-705D	T4-12471			w/s. washer	Z4 5069
2-47	ML721541	Brake Lever CS-705D	T4-6003	2-102	ZS722136	Screw, binding head M2.6x14	
2-48	ZG721563	Head Base Holding Spring				CS-705D	Z4-5735
		CS-705D	T4 7016	2-103	ZS323728	Screw, binding head 3x5	Z4-2375
2-49	MB701111	Belt (Capstan) 62.25x5x0.4		2-104	ZS721394	Tapping Screw, pan head #2	
		CS-705D	T4-11840			M2x6 CS-705D	Z4-5054
2-50	MB701122	Belt (Take-up) 1x56.7 CS-705D	T4-11841	2-105	ZW740397	Washer M1.6x6x0.2 (Teflon)	Z4 5843
2-51	MB721607	Motor Installation Rubber		2-106	ZW740398	Washer M6.2x9.5x0.15 (Lumilar)	Z4 5844
		CS-705D	T4-7840	2-107	ZW722171	Washer (Lumilar) M1.8x3x0.2	
						CS-705D	Z4 5194

When ordering parts, please describe Parts Number, Description, and Model Number in detail.

Ref. No.	Parts No.	Description	Schematic No.
2-108	ZW722182	Flat Washer M4x0.8 CS-705D	Z4 5114
2-109	ZW722193	Flat Washer M2.6x0.5 CS-705D	Z4 5111
2-110	ZW722204	Washer (Teflon) CS-705D	Z4 5117
2-111	ZW722215	Flat Washer M2.5x0.25 CS-705D	Z4 5128
2-112x	ZW721135	Flat Washer M25x0.1 CS-705D	Z4 5137
2-113	ZW721181	Polyslider Washer M1.6x0.25 CS-705D	Z4 5141
2-114x	ZW740399	Washer D2.5x0.25 (Polyslider)	Z4 5166
2-115x	ZW700380	Spring Washer M2.6	
2-116	ZW740400	Washer M2.5x0.2	Z4 5190
2-117	MH740401	Head Adjust. Spacer	T4 11562
2-118	ZW356657	'E' Ring 1.5M	6 1 9
2-119	ZW270112	'E' Ring 3.2	6 1 9
2-120	ZW623282	'E' Ring 4M	6 1 13
2-121	ZW410051	'E' Ring 2.5	6 1 9
2-122	MV357208	Steel Ball D2	
2-123	MV666887	Steel Ball D2.5	
2-124	BA722496	Mute P.C Board Comp. CS-705D	TA4 8937
2-125	ES740342	Leaf SW.	T4 18346

3. TONE CONTROL & REC/PB P.C BOARD (AC-3501A) BLOCK

Symbol No.	Parts No.	Description	Schematic No.	Qty
3-1	BA290632	Tone Control & Rec/PB P.C Board Comp. AC-3500		1
3-IC1	E1605013	IC NE545B	45 8 117	2
3-TR1to3	ET223446	Transistor 2SC1571NP(G)(H)	45 1 238	6
3-TR4,5	ET639437	Transistor 2SC945L(Q)(P)	45-1 85	4
3-TR6,7	ET223446	Transistor 2SC1571NP(G)(H)	45-1 238	4
3-D1to3	ED562386	Germanium Diode 1S188AM	45 3 24	6
3-L1	EO299384	Inductor RX-9P 4.7MH(K)	23 1 275	2
3-L2	EO299373	Inductor RX-9P 22MH(K)	23 1 275	2
3-FL1	ER669734	MPX Filter FB1801M	53 1 104	2
3-J1,2	EJ299283	Mic. Jack HLJ273-1-080	31 2 82	2
3-SW1,2	ES299327	Push SW. JP7134	25 5 248	1
3-SW3	ES299362	Slide SW. CL212E	25 3 134	1
3-SW4,5	ES299294	Push SW. JP-7135	25-5 249	1
3-VR1	EV522797	Semi-fixed/Vol. V8K4-1 20 kB	36 10 266	2
3-VR2	EV299338	Double axial 2 throw Vol. V24L5DGPHN 15A 50kx2	36 3 80	1
3-VR3,4	EV520806	Semi-fixed/Vol. V8K4-1 10 kB	36-10-266	4
3-VR5	EV299351	Double axial 2 throw Vol. V24L5DGPHN 3B 250kx2	36 3 79	1
3-VR6,7	EV299340	Single axial 2 throw Vol. V16L4PHN 100 kBx2	36 22 25	2
3-2	ZS379350	Screw, pan head 3x6		4
Capacitor, Vertical Type				
3-C1	EC676721	Styrol/C. 470PF(K) 50WV	24-11-11	2
3-C4	EC299395	Styrol/C. 750PF(K) 50WV	24-11-3	2
3-C12	EC621257	Solid Aluminum/C. 0.47μF(M) 25WV	24 19 2	2
3-C15	EC638177	Solid Aluminum/C. 1μF(M) 25WV	24 19 2	2
3-C20	EC604440	Solid Aluminum/C. 0.33μF(M) 25WV	24 19 2	2
3-C21	EC523282	Solid Aluminum/C. 0.1μF(M) 25WV	24 19 2	2
3-C27	EC523282	Solid Aluminum/C. 0.1μF(M) 25WV	24 19 2	2
3-C38	EC621257	Solid Aluminum/C. 0.47μF(M) 25WV	24 19 2	2

4. MULTI FUNCTION P.C BOARD (AC-3801A) BLOCK

Symbol No.	Parts No.	Description	Q'ty
4-1	BA300702	Multi Function P.C Board Comp. AC-3800	1
4-2	BA300703	Multi Function P.C Board Comp. AC-3800L	1
4-IC1	E1697871	IC LA-3122S	45-8-185 1
4-IC2	E1299441	IC TA7303P(C)	45-8-216 1
4-IC3	E1650597	IC LA-3350S	45-8-153 1
4-IC4	E1299700	IC HA1197	45-8-218 1
4-TR1	ET618873	Transistor 2SC930(E)(F)	45-1-185 1
4-TR2,3	ET639437	Transistor 2SC945L(Q)(P)	45-1-85 2
4-TR4	ET639437	Transistor 2SC945L(Q)(P) (AC-3800L)	45-1-85 1
4-D1	ED624903	Silicon Diode IS2473	45-3-28 1
4-L1	EO539820	Peaking Coil 2.2 μ H(K)	23-1-187 1
4-L2,3	EO650428	Inductor 146V 39 μ H(J)	23-1-214 2
4-T1	BT299575	FM-IF Trans. 154AC-41345Z	23-1-274 1
4-T2	EO293387	OSC Coil RWR-42282N	23-4-41 1
4-T3	EO-299564	OSC Coil LW RWR-43115N (AC-3800L)	23-4-42 1
4-T4	BT293398	AM-IF Trans. 10EZ RMC-42246BCH 46	23-1-276 1
4-T5	BT650384	AM-IF Trans. CFU-085-D 468kHz	23-1-241 1
4-FL1,2	ER650430	Ceramic Filter SFE-10.7 MA-8-Z	53-1-102 2
4-TC1,2	EC616342	Trimmer/C. CTY-15D33 12PF	24-2-32 2
4-TC1,2	EC675742	Trimmer/C. CTY-21D 15PF (AC-3800L)	24-2-35 2
4-J1	EJ283094	4P Pin Jack 1-01-0107-00	31-5-137 1
4-P1	EJ207854	3P Plug PC	42-1-96 1
4-SW1	ES300761	Rotary SW. SR26(PH-2)N 3-8-4	25-6-111 1
4-SW1	ES300760	Rotary SW. SR26(PH-2)N 4-13-5 (AC-3800L)	25-6-112 1
4-VR1	EV478686	Semi-fixed/Vol. V8K4-1 1k Ω	36-10-266 1
4-VR2,3	EV464207	Semi-fixed/Vol. V8K4-1 5k Ω	36-10-266 2
4-3	EE300785	Varactor Tuner VFT-22UH-31	57-2-43 1
		Capacitor, Vertical Type	
4-C35	EC214558	Styrol/C. 1500PF(J) 50WV	24-11-3 1
4-C37	EC215065	Solid Aluminum/C. 0.47 μ F(M) 16WV	24-19-2 1
4-C53	EC650406	Styrol/C. 310PF(J) 50WV	24-11-3 1

5. POWER, SYS. CON & OSC P.C BOARD (AC-3503) BLOCK

Symbol No.	Parts No.	Description	Q'ty
5-1	BA300961	Power, Sys. Con & Osc P.C Board Comp.	AC-3848 1
5-2	BA300963	Power, Sys. Con & OSC P.C Board Comp. (CSA)	AC-3848 1
5-3	BA300971	Power, Sys. Con & Osc P.C Board Comp. (CEE)	AC-3848 1
5-TR1	ET649034	Transistor 2SC1449(K)(L)	45-1-214 1
5-TR2	ET639437	Transistor 2SC945L(Q)(P)	45-1-85 1
5-TR3	ET452531	Transistor 2SD313(E)(F)	45-1-105 1
5-TR4	ET554657	Transistor 2SA733(P)(Q)	45-1-124 1
5-TR5,6	ET639437	Transistor 2SC945L(Q)(P)	45-1-85 2
5-TR7	ET299531	Transistor 2SB544MP(E)(F)	45-1-258 1
5-TR8	ET299507	Transistor 2SD400MP(E)(F)	45-1-259 1
5-D1to4	ED245417	Silicon Diode GP20G	45-2-70 4
5-D5to10	ED224526	Silicon Diode 10D1	45-2-11 6
5-D11	ED290722	Zener Diode RD-16E(C) (U/T)	45-6-72 1
5-D11	ED300269	Zener Diode RD-9-1E(B) (CSA, CEE)	45-6-72 1
5-D12	ED560913	Silicon Diode IS2473VE	45-3-23 1
5-D14	ED300269	Zener Diode RD-9-1E(B) (CSA, CEE)	45-6-72 1
5-D15,16	ED224526	Silicon Diode 10D1 (CEE)	45-2-11 2
5-VR1,2	EV464231	Semi-fixed/Vol. V8K4-1 100 k Ω	36-10-266 2
5-T1	EO290744	Osc. Coil 13Y-033-1639	23-4-43 1
5-4	ZS325495	Tapping Screw #2, 3x6 (BR)	1
5-R4	ER303699	Metal Oxide Film/R. 2W 56 ohms(K) (U/T)	35-15-18 1
5-C1	EC684720	Ceramic/C. CLD16YE 0.01 μ F(P) 500WV	24-5-61 1
5-C2	EC684720	Ceramic/C. CLD16YE 0.01 μ F(P) 500WV (U/T CEE)	24-5-61 1
5-C3to6	EC684720	Ceramic/C. CLD16YE 0.01 μ F(P) 500WV	24-5-61 4
5-C7,8	EC219936	Elect./C. (Vert. Type) 4700 μ F 35WV	24-10-116 2
5-C10	EC220421	Elect./C. (Vert. Type) 1000 μ F 16WV	24-12-9 1
5-C21	EC520773	Styrol/C. (Tub. Type) 2000PF(J) 250WV	24-11-10 1
5-C26,27	EC684720	Ceramic CLD16YE 0.01 μ F(P) 500WV (CSA)	24-5-61 2

6. MAIN AMP P.C BOARD (AC-3504) BLOCK

Symbol No.	Parts No.	Description	Schematic No.	Q'ty
6-1	BA301497	Main Amp P.C Board Comp. AC-3849	AC-3849	1
6-2	BA301498	Main Amp P.C Board Comp. (CSA) AC-3849	AC-3849	1
6-3	BA301499	Main Amp P.C Board Comp. (CEE) AC-3849	AC-3849	1
6-1C1	E1299608	IC STK-078	45 8 219	2
6-L1	EO650823	Phase Compensation Coil 2.2μH(K)	23-1 239	2
6-4	ZS462802	Tapping Screw #2, 3x15(BR)		4
6-5	ZS325495	Tapping Screw #2, 3x6(BR)		6
6-C2	EC516767	Styrol/C. (Vert. Type) 470PF(K) 50WV	24-II-3	2

7. IC P.C BOARD (AC-3803) BLOCK

Symbol No.	Parts No.	Description	Schematic No.	Q'ty
7-1	BA300361	IC P.C Board Comp. AC-3800	AC-3850	1
7-1C1	E1303086	IC LB1500	45-8 236	1
7-1C2	E1300182	IC LB1515	45-8-221	1
7-1C3	E1303086	IC LB1500	45-8 236	1
7-D1	ED624903	Silicon Diode 1S2473	45 3-28	1

8. VOL. P.C BOARD (AC-3804) BLOCK

Symbol No.	Parts No.	Description	Schematic No.	Q'ty
8-1	BA300187	Vol. P.C Board Comp. AC-3800	AC-3851	1
8-2	BA301615	Vol. P.C Board Comp. AC-3800-BL	AC-3851	1
8-D1	ED300184	Zener Diode RD27E (Special)	45 6 75	1
8-L1	EO350796	Ferri Inductor FL5H 330μH(K)	23-1 2	1
8-VR1to5	EV229915	Pre-set Vol. (w/Knob) LFQDR504 100KB	36 37-1	5
8-VR1to5	EV288437	Pre-set Vol. (w/Knob) LFQDR002 100KB (AC-3800-BL)	36 37-2	5

9) TURN TABLE BLOCK (1)

Ref. No.	Parts No.	Description	Schematic No.
9-1	MV719133	Gear Shaft Holder AP-003	2077376700
9-2	ZS712091	Tapping Screw #2, 3x8 (BR) w/washer	2078591600
9-3	TP740363	Reject Base AC-3800	2074391600
9-4	TP740364	Select Base AC-3800	2074391500
9-5	TP740365	PU Rest Comp. AC-3800	2073865400
9-6	TP740366	PU Stand AC-3800	2073563800
9-7	TP740367	Main Gear AC-3800	2072763800
9-8	TP719098	Auto Stop AP-003	2075170400
9-9	TP719100	Auto Clutch AP-003	2075172900
9-10	TP740368	Hand Clutch AC-3800	2075378200
9-11	TP740372	Return Cam AC-3800	2075770100
9-12	BL719256	Reject Lever Block Comp. AP-003	2075175300
9-13	MS715555	Stopper Shaft	2076382400
9-14	TP719267	Gear Stopper AP-003	2074673700
9-15	ZG715577	Pull Coil Spring -	2070560100
9-16	TP740374	Reject Pole AC-3800	2070769100
9-17	SK740375	Knob AC-3800	2087190800
9-18	ZS740376	Tapping Screw, 2.6x8 w/washer	2270154900
9-19	TP740373	Reject Plate AC-3800	2075393300
9-20	ZG715814	Pull Coil Spring	2070563400
9-21	TP740377	Lifter Bar Comp. AC-3800	2076471000
9-22	TP740378	Lifter Shaft AC-3800	2076466900
9-23	ZG719403	Coil Spring, compression AP-003	2070380300
9-24	SK740380	Lifter Knob AC-3800	2087190700
9-25	TP740381	Lifter Cam AC-3800	2075769600
9-26	ZW740382	Washer D4.7x10x0.18t	2079166000
9-27	TP740383	Lifter Lever Comp. AC-3800	2075388400
9-28	ZG740384	Plate Spring AC-3800	2070966000
9-29	ZW715612	Special Washer D3.2x9.5x0.5t	2079162500
9-30	MV740385	Steel Ball AC-3800	2077370600
9-31	MB719008	Belt AP-003	2072861700
9-32	TP740404	Belt Guide AC-3800	2274355400
9-33	TP740405	Select Plate AC-3800	2075393400
9-34	ZG740406	Torsion Spring AC-3800	2070769200
9-35	TP740408	Turn Table AC-3800	2072368300
9-36	TP709503	Table Sheet AP-001/C	2072368600
9-37	TP740409	Table Shaft Part AC-3800	2072568900
9-38	MV715307	Table Shaft Holder AP-005	2072566000
9-39	ZW719043	Special Nut AP-003	2079663100
9-40	ZW719054	Washer 91x340x8MS AP-003	2079193700
9-41	TP740413	Pick-up Arm Block Comp. AC-3800	2073183300
9-42	TP740414	Main Weight AC-3800	2073182600

9. ILLUSTRATION OF TURN TABLE BLOCK (1)

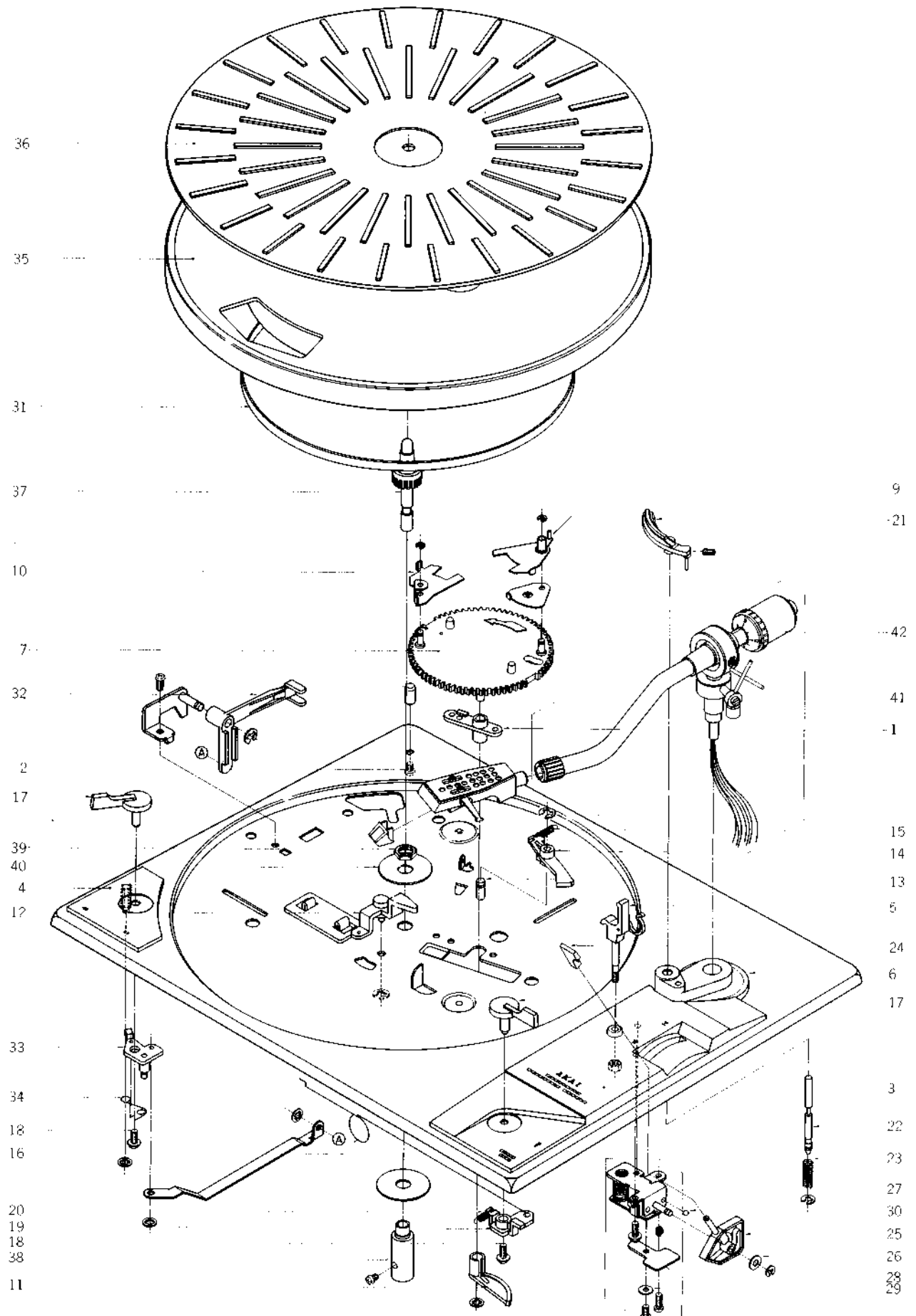

10. ILLUSTRATION OF TURN TABLE BLOCK (2)

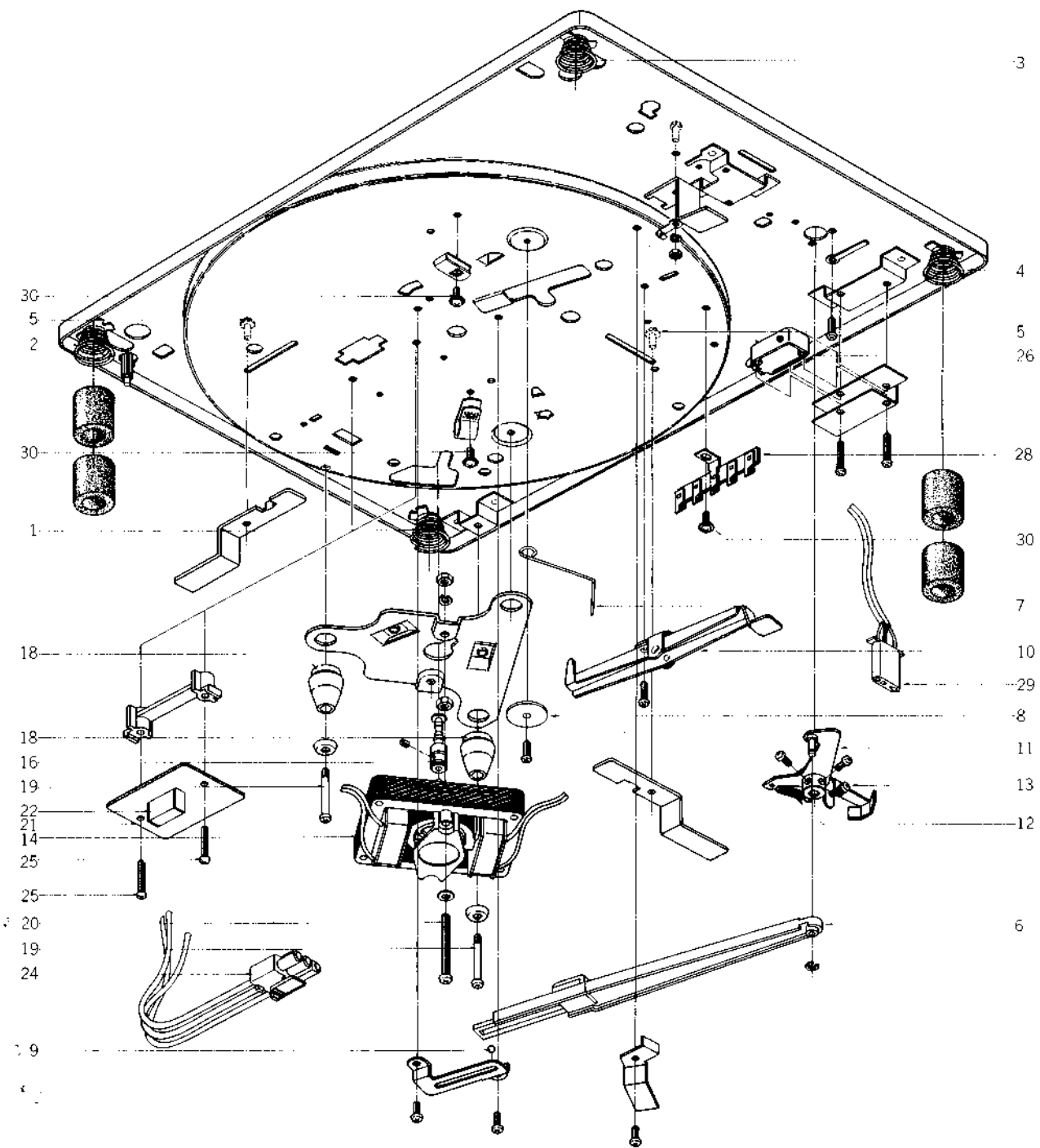

10) TURN TABLE BLOCK (2)

Ref. No.	Parts No.	Description	Schematic No.
10-1	ZG740359	Panel Spring (A) (Black) AC-3800	2070372900
10-2	ZG740360	Panel Spring (B) (Red) AC-3800	2070373000
10-3	ZG740361	Panel Spring (C) (Green) AC-3800	2070373100
10-4	ZG740362	Panel Spring (D) (Blue) AC-3800	2070373200
10-5	ZS369900	Screw, pan head 3x8, w/washer	
10-6	SL719155	Auto Lever AP-003	2075393100
10-7	TP740369	Return Lever AC-3800	2076468200
10-8	ZW740370	Special Washer AC-3800	2275285800
10-9	MV740371	Steel Ball AC-3800	2077370900
10-10	BL719370	Seesaw Lever Block Comp. AP-003	2075388800
10-11	BD719414	Pick-up Plate Block Comp. AP-003	2075177200
10-12	ZG715465	Pull Coil Spring	2070569200
10-13	ZG740379	Clamp Spring AC-3800	2070375400
10-14	BW740386	AC Motor SD235S3 (CEE, U/T)	2212546100
10-15x	BM740387	AC Motor SD235E3 (CSA)	2212546200
10-16	TP740388	Motor Pulley (50 Hz) AC-3800	2071675300
10-17x	TP740389	Motor Pulley (60 Hz) AC-3800	2071675400
10-18	TP740402	Rubber Cushion AC-3800	2275682800
10-19	TP740403	Shaft AC-3800	2076468600
10-20	ZS434250	Screw, pan head 4x8, w/washer	
10-21	EA740410	P.C Board AC-3800	2214341800
10-22	EC709920	⌘ Metalized/C. 0.047μF AC250V	2238011400
10-23x	EC720101	⌘ Metalized/C. 0.1μF 125V AC (CSA)	2237016300
10-24	EW740411	Power Cord (w/3P plug) AC-3800	2216470100
10-25	ZS711887	Tapping Screw #2, 3x20 (BR)	2079591700
10-26	ES709817	⌘ Micro SW. VV5-1A442-D(S) 5A 250V(BSI)	2214035100
10-27x	ES718648	⌘ Micro SW. K-2 AP-003(CSA)	2214633500
10-28	EJ740349	Terminal 4P AC-3800	2216126100
10-29	EW740412	PU Cord (w/3P plug) AC-3800	2216470200
10-30	ZS712091	Tapping Screw #2, 3x8(BR) w/washer	2079591600

11. ILLUSTRATION OF ASSEMBLY BLOCK

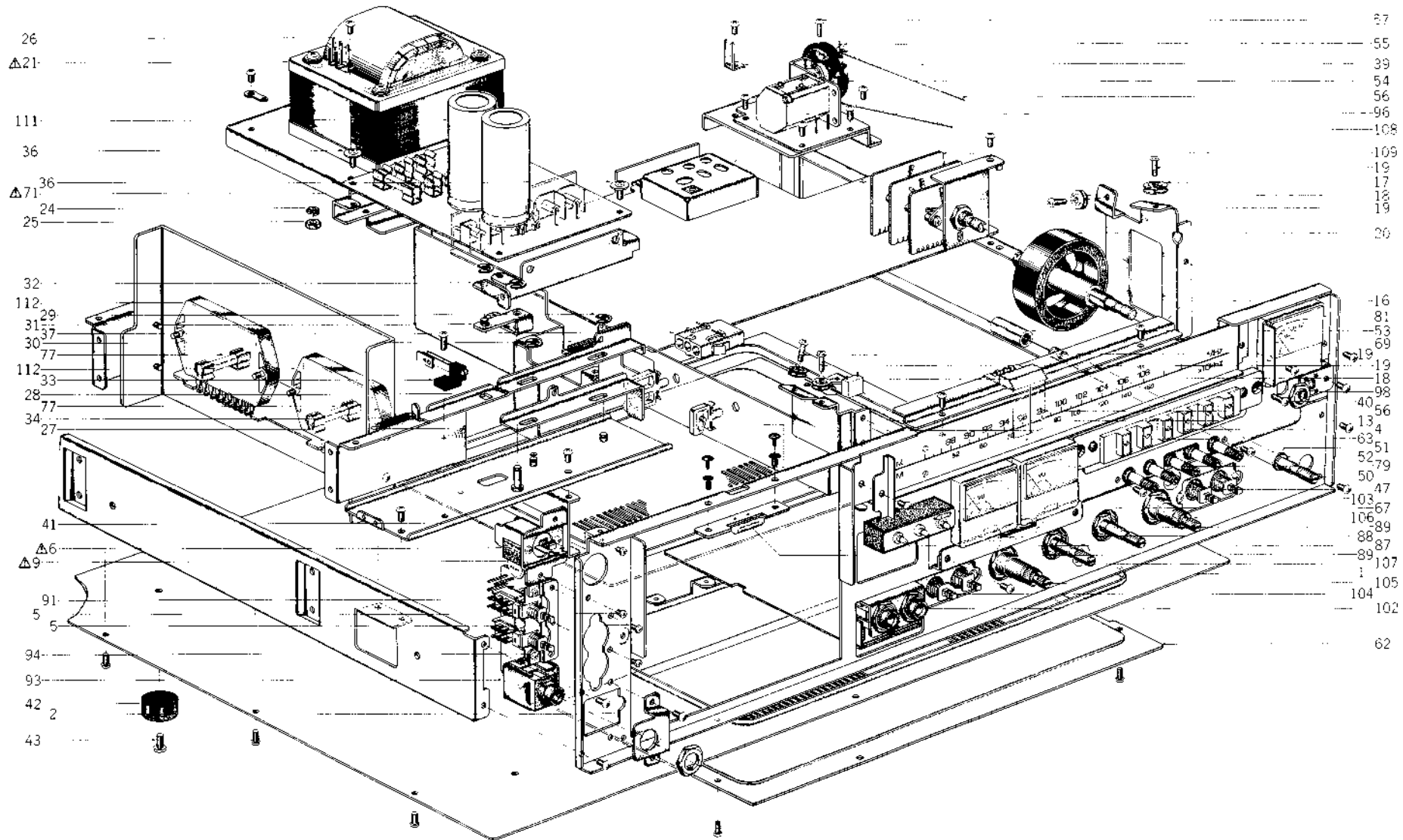

11) ASSEMBLY BLOCK

Ref. No.	Parts No.	Description	Schematic No.	Q'ty	Ref. No.	Parts No.	Description	Schematic No.	Q'ty
11-1	SP300659	Bottom Plate	AC 3805	1	11-49x	ZW698940	Nylon Rivet (FNRP) 4x6 (Black)	2 7 58	2
11-2	ZS325495	Tapping Screw #2, 3x6 (BR)		69	11-50	MS300639	Relay Shaft	AC 3824	1
11-3x	ZS447761	Tapping Screw #2, 3x6 (BR) (Black)		10	11-51	ZW270123	'E' Ring 4M	6 1 9	2
11-4	ZW698308	Nylon Rivet (FNRP) 3x5.5 Black	2 7 54	2	11-52	ZW322110	Washer (Nylon) D6.1x10.3x1.0t		1
11-5	ZS379350	Screw, pan head 3x6		18	11-53	TA646773	Joint	AA 5240	1
11-6	ES224436	A. Push SW. JP01 (U/F)	25 5 221	1	11-54	TA300423	Dial Wheel	2 15 16	1
11-7x	ES239218	A. Push SW. JP01 (TV-4) (CSA)	25-5-222	1	11-55	ZS300421	Dial Wheel Spring	AC 3551	1
11-8x	ES242346	A. Push SW. JP17 (CEE, BEAB)	25 5 224	1	11-56	TA207347	Thread D0.5 (1.8mm)		1
11-9	EC684720	A. Ceramic/C. CLD16YE 0.01μF(P) 500WV(U/T)	24 5 61	1	11-57	ZS421806	Screw, pan head 3x8		2
11-10x	EC294118	A. Ceramic/C. DPN6600 YM 0.01μF(P) 125WV (CSA)	24 5 70	1	11-58	TA300418	Pointer Part-G	AC 3557	1
11-11x	EC301320	A. MP/C. PME271Y447 4700PF 250WV (CEE, BEAB) (*C901)	24-9-118	1	11-59x	EF602550	A. Fuse (SEMKO T Type) 1.25AT 250V (CEE, BEAB)	39 1 53	4
11-12x	EC301320	A. MP/C. PME271Y447 4700PF 250WV (CEE, BEAB) (*C902)	24 9 118	1	11-60	EJ254970	Lug Plate KP111 (CEE, BEAB)	33 3 3	1
11-13	EO263068	Inductor 144LZ 2.2μH(K)	23-1-240	1	11-61x	ZS447840	Tapping Screw #2, 3x8 (BR)		6
11-14x	ED224526	Silicon Diode 10D1	45-2 11	1	11-62	SP300657	Bottom Plate (C)	AC 3826	1
11-15x	ZS300425	Screw, pan head 3x6 w/s. washer		7	11-63	TA301140	Scale Plate (C)	AC 3512	1
11-16	TA286626	Rail	AC-3520	1	11-64x	TA301312	Scale Plate (C-BL)	AC 3512	1
11-17	MR530651	Roller A	91 5008	1	11-65x	TA301141	Scale Plate (D)	AC 3512	1
11-18	MR530662	Roller B	91 5009	3	11-66x	TA301313	Scale Plate (D-BL)	AC 3512	1
11-19	ZS530673	Roller Screw A	91-5010	4	11-67	TA286525	Plate (L), Dummy	AC 3513	1
11-20	ML300419	Tuning Wheel Part-G	13 2 26	1	11-68x	TA301310	Plate (L-BL), Dummy	AC 3513	1
11-21	BT698804	A. Power Trans. AC-3000T-1 (U/T)	38-4-489	1	11-69	TA286536	Plate (R), Dummy	AC 3514	1
11-22x	BT304318	A. Power Trans. AC-3000T-4 (CSA)	38 4-557	1	11-70x	TA301311	Plate (R-BL), Dummy	AC 3514	1
11-23x	BT294131	A. Power Trans. AC-3000T-3 (CEE, BEAB)	38-4-491	1	11-71	EF563703	A. Fuse 2A 250V (U/T)	39 1 50	1
11-24	ZW273914	Spring Washer		4	11-72x	EF590692	A. Fuse 1.2A 250V (U/T)	39 1 50	1
11-25	ZW413188	Nut M4, #1		4	11-73x	EF563703	A. Fuse 2A 250V (CSA)	39 1 50	1
11-26	EJ551035	Wrapping Terminal, 4P T-5251	32 1-36	1	11-74x	EF623103	A. Fuse (SEMKO T Type) 1AT (CEE, BEAB)	39 1 53	2
11-27	ML286457	Lever (3)	AC-3524	1	11-75x	EF563681	A. Fuse 1A 250V (CSA)	39 1 50	2
11-28	ML286604	Lever (4)	AC-3525	1	11-76x	EF623103	A. Fuse (SEMKO T Type) 1AT (CEE, BEAB)	39 1 53	2
11-29	ZW290283	'U' Ring 2.85M	61-1	4	11-77	EF563657	Fuse 3A250V (U/T, CSA)	39 1 50	2
11-30	ZG300739	Rec Lever spring	AC-3561	1	11-78x	EF300580	Fuse (EAK) 2.5AT (CEE, BEAB)	39 1 59	2
11-31	ML290902	Lever (2) Part AC-3500		1	11-79	EM698815	VU Meter KL-218D-104 (3800/L)	46 1 162	2
11-32	ML286470	Lever (1)	AC-3522	1	11-80x	EM301306	VU Meter KL-218D-106 (3800BL/L-BL)	46 1 173	2
11-33	ES592964	Leaf SW. BSW-1F TX	35-10-18	1	11-81	EM300759	Pre-set Tuning Meter KL-218D-107 (3800/L)	46 1 168	1
11-34	ZG431897	Slide SW. Return Spring	ED B112	1	11-82x	EM301315	Pre-set Tuning Meter KL-218D-108 (3800BL/L-BL)	46 1 174	1
11-35x	ZW270088	'E' Ring 1.9M	6 1 9	1	11-83x	ZW562476	Earth Lug M3 (CSA)		1
11-36	ZS302024	Tapping Screw #2, 3x8 (Pan) W=10		4	11-84x	ZS666336	Tapping Screw #2, 3x8 (Pan) (CSA)		1
11-37	EJ303571	3P Pin Lock Connector Part (1)(U/T, CSA)	26 6 272	1	11-85x	ER300744	Cement/R. (Wire-wound Type) 2W 68 ohms(J) (CEE, BEAB)	35 16 57	1
11-38x	EJ303572	3P Pin Lock Connector Part (2)(CEE, BEAB)	26-6-273	1	LED P.C BOARD COMP.				
11-39	EJ539447	Earth Terminal 2P T4460	32-1 32	1	11-86	BA304296	LED P.C Board Comp. AC-3800	AC 3568	1
11-40	ZS523664	Tapping Screw #2, 3x10 (BR)		2	11-87	ED698826	LED SR-105D	45 15 16	2
11-41	SP300656	Bottom Plate (B)	AC-3825	1	11-88	ED283138	LED GL-3PG1	45 15 15	1
11-42	SA301770	Tran Leg (J)	2 6 18	4	LAMP P.C BOARD COMP.				
11-43	ZS565942	Tapping Screw #2, 4x8 (Pan)		4	11-89	EL283184	Lamp (L/T) 8V 100mA	28 2 59	1
11-44x	ZS434250	Screw, pan head 4x8, w/washer (CEE, BEAB)		1	HEADPHONE P.C BOARD COMP.				
11-45x	ZW413188	Nut M4, #1 (CEE, BEAB)		1	11-90	BA290654	Headphone P.C Board Comp. AC-3500	AC 3580	1
11-46x	ZW273881	Earth Lug (CEE, BEAB)		1	11-91	ES698927	Push SW. JP-7136	25 5-250	1
FINAL ASSEMBLY BLOCK					11-92x	ER246363	Metal Oxide Film/R. 2W 220 ohms(K)	35-15 18	2
11-47	ZS417216	Screw, pan head 3x4		7	11-93	EJ225022	Headphone Jack LJ255-1-12	31-2 77	1
11-48x	ER300744	Cement/R. (Wire-wound Type) 2W 68 ohms(J) (BEE, BEAB)	35 16 57	1	11-94	ZS417216	Screw, pan head 3x4		2

When ordering parts, please describe Parts Number, Description, and Model Number in detail.

Ref. No.	Parts No.	Description	Schematic No.	Qty
VARI. CON P.C BOARD COMP.				
11-95	BA300358	Vari. Con P.C Board Comp. AC-3800	AC 3855	1
11-96	EE300181	Vari. Con CY21W-121	24 2 41	1
11-97x	EV522797	Semi-fixed/Vol. V8K4-1 20 kB	36 10 266	1
LAMP P.C BOARD (C) COMP.				
11-98	EL300186	Lamp 8V 60 mA	28 2 62	1
TOUCH SW. P.C BOARD COMP.				
11-99	BA300364	Touch SW. P.C Board Comp. AC-3800	AC-3856	1
11-100x	BA301614	Touch SW. P.C Board Comp. AC-3800BL	AC 3856	1
11-101x	ED653624	LED SFL-103W	45-15-9	7
TONE CONTROL & REC/PB P.C BOARD COMP.				
11-102	EJ299283	Mic Jack HLJ273-1-080	31-2-82	2
11-103	ES299327	Push SW. JP-7134	25 5-248	1
11-104	ES299294	Push SW. JP-7135	25-5-249	1
11-105	EV299338	Double axial 2 throw Vol. V24L5DGPHN 15A 50kx2	36 3 80	1
11-106	EV299351	Double axial 2 throw Vol. V24L5DGPHN 3B 250kx2	36 3 79	1
11-107	EV299340	Double axial 2 throw Vol. V16L4PHN 100 kBx2	36-22 25	2
MULTI FUNCTION P.C BOARD COMP.				
11-108	EE300785	Varactor Tuner VFT-22UH-31	57-2 43	1
11-109	ES300761	Rotary SW. SR26(PH-2)N 3-8-4	25 6 111	1
11-110x	ES300760	Rotary SW. SR26(PH-2)N 4-13-5 (3800L)	25-6-112	1
POWER, SYS. CON & OSC P.C BOARD COMP.				
11-111	EC219936	Elect./C. (Vert. Type) 4700µF 35WV	24-12-17	2
MAIN AMP P.C BOARD COMP.				
11-112	EI299608	IC STK-078	45-8-219	2
VOL. P.C BOARD COMP.				
11-113	EV229915	Pre-set Vol. (w/knob) LFQDR504 100 kB	36-37-1	5
11-114x	EV288437	Pre-set Vol. (w/knob) LFQDR002 100 kB (3800BL)	36-37 2	5

12. ILLUSTRATION OF REAR PANEL BLOCK (AC-3800)

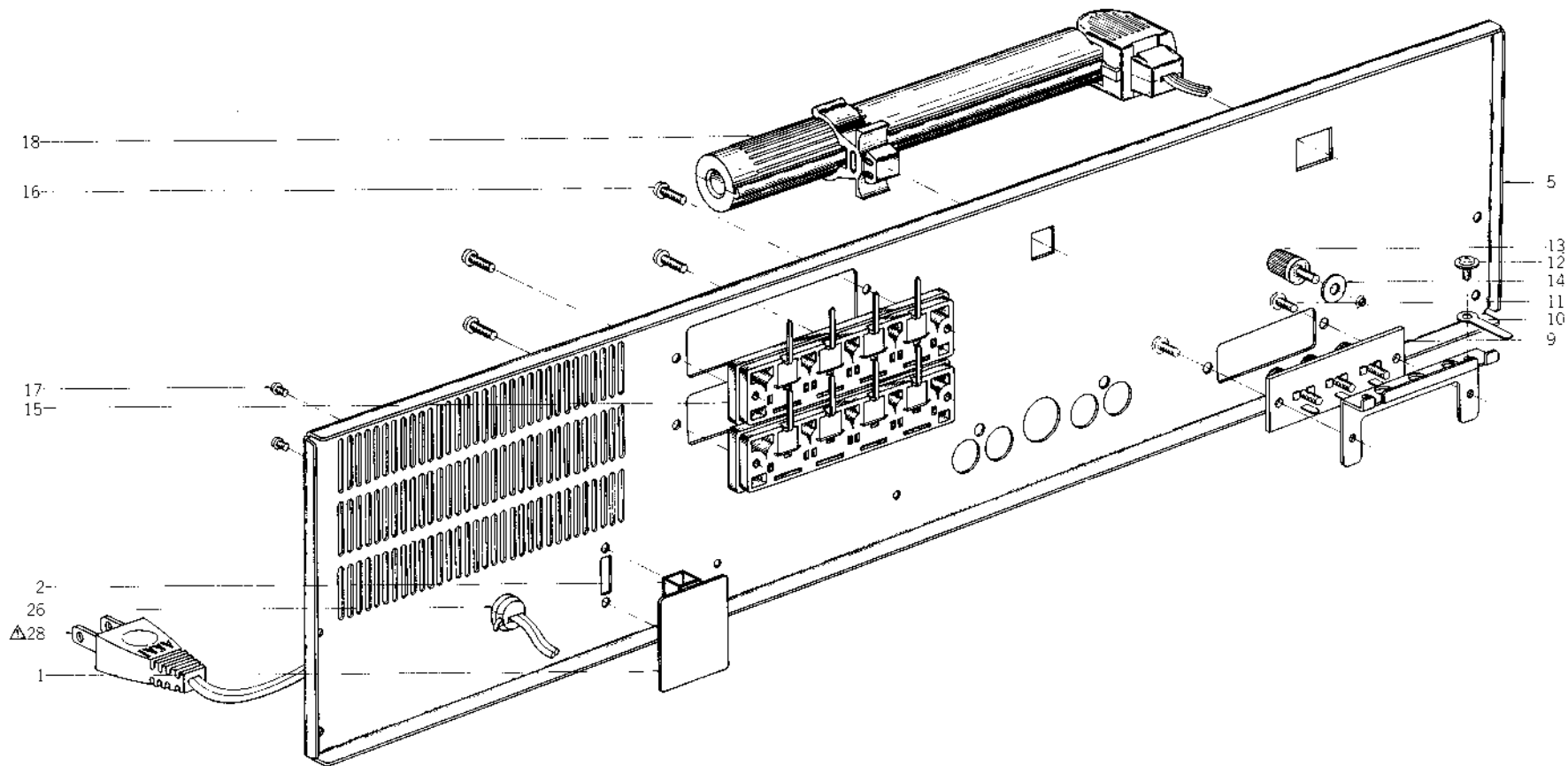

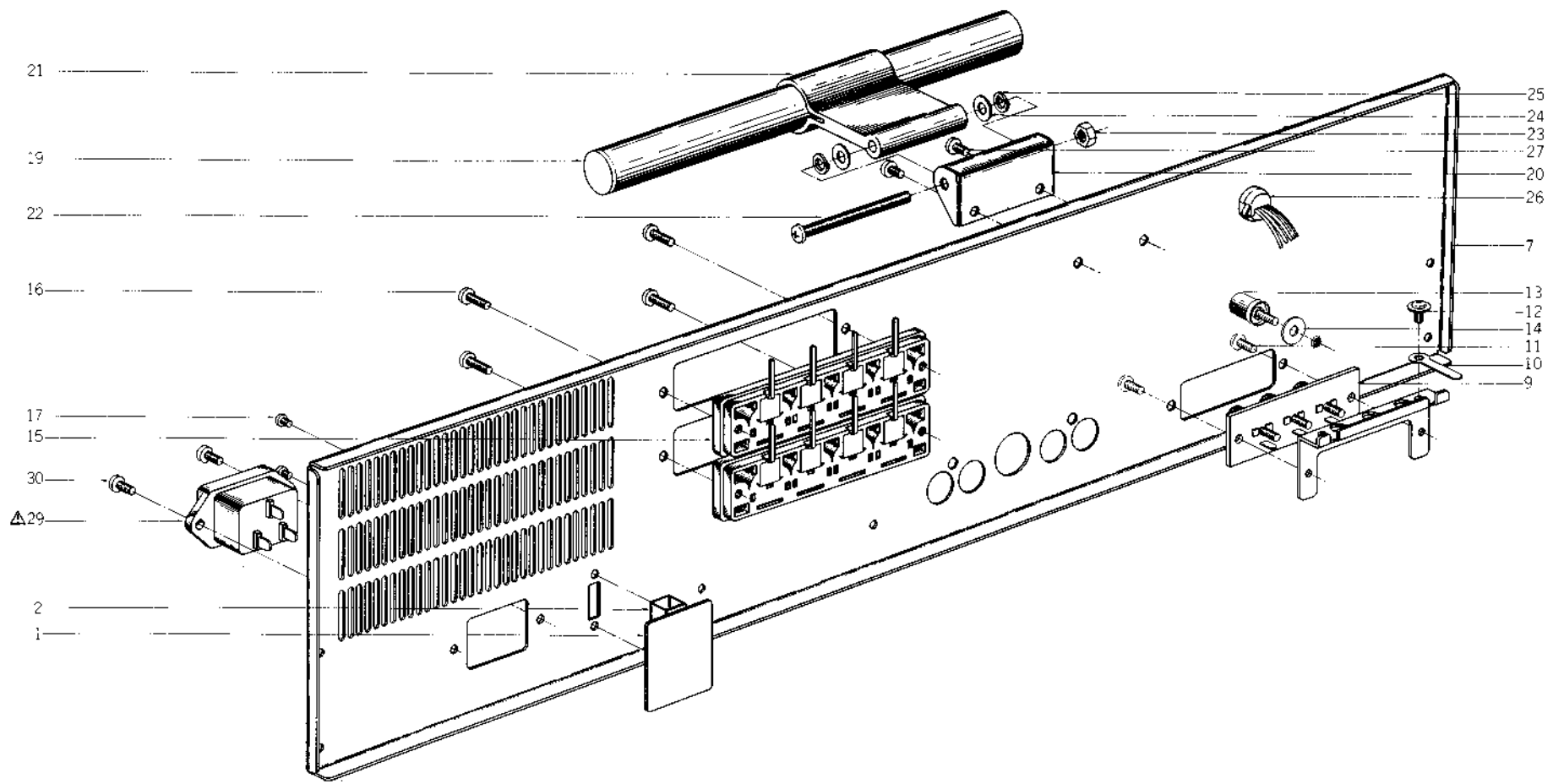

12. ILLUSTRATION OF REAR PANEL BLOCK (AC-3800L)

12) REAR PANEL BLOCK

Ref. No.	Parts No.	Description	Schematic No.	Q'ty
BEAT SW. P.C BOARD COMP.				
12-1	BA300974	Beat SW. P.C Board Comp. AC-3800		1
12-2	ES246227	Slide SW. SSC323E	25-3-119	1
12-3x	EC299553	Styrol/C. (Tub. Type) 220PF(K) 250WV	24-11-10	1
12-4x	EC298563	Styrol/C. (Tub. Type) 470PF(K) 250WV	24-11-10	1
REAR PANEL BLOCK				
12-5	SP300665	Rear Panel (A) (3800) (U/T)	AC-3811	1
12-6x	SP300667	Rear Panel (B) (3800) (CSA)	AC-3811	1
12-7	SP300670	Rear Panel (L-B) (3800L) (CEE)	AC-3813	1
12-8x	SP300671	Rear Panel (L-C) (3800L) (BEAB)	AC-3814	1
12-9	EJ293646	3P Antenna Terminal Plate	32-1-78	1
12-10	ZW273767	Earth Lug D3x20L		2
12-11	ZS498273	Tapping Screw #2, 3x8 w/washer		2
12-12	ZS355522	Screw, pan head 3x6		2
12-13	SK652397	Knob 0512-2	34-1-4	1
12-14	ZW652408	Washer (SPC) D3.2x10x0.5t		1
12-15	EJ240581	4P Push Terminal	32-1-72	2
12-16	ZS522865	Tapping Screw #2, 3x12 (BR)		4
12-17	ZD608185	Screw, pan head 2.6x4		2
12-18	EE299621	Bar Antenna	55-1-49	1
12-19	EE298337	Bar Antenna (3800L)	55-1-50	1
12-20	TA530910	Antenna Channel (3800L)	91-5029	1
12-21	TA625847	Antenna Holder (3800L)	2-7-46	1
12-22	ZS552600	Screw, pan head 4x50 (3800L)		1
12-23	ZW604416	Nut M4 (3800L)		1
12-24	ZW420682	Washer (Nylon) D4.2x9x0.5t (3800L)		2
12-25	ZW273914	Spring Washer (3800L)		2
12-26	EZ631945	Strain Relief SR-4N-4 (3800L)		2
12-27	ZS447761	Tapping Screw #2, 3x6 (BR) (Black) (3800L)	2-7-49	2
12-28	EW374894	△ AC Cord CUL 3M (U/T, CSA)		1
12-29	EJ296853	△ 3P In-Let CM-3 (CEE, BEAB)	26-3-19	1
12-30	ZS463353	Tapping Screw #2, 3x8 (BR) (CEE, BEAB)	31-1-199	2

13. PHOTO OF FINAL ASSEMBLY BLOCK

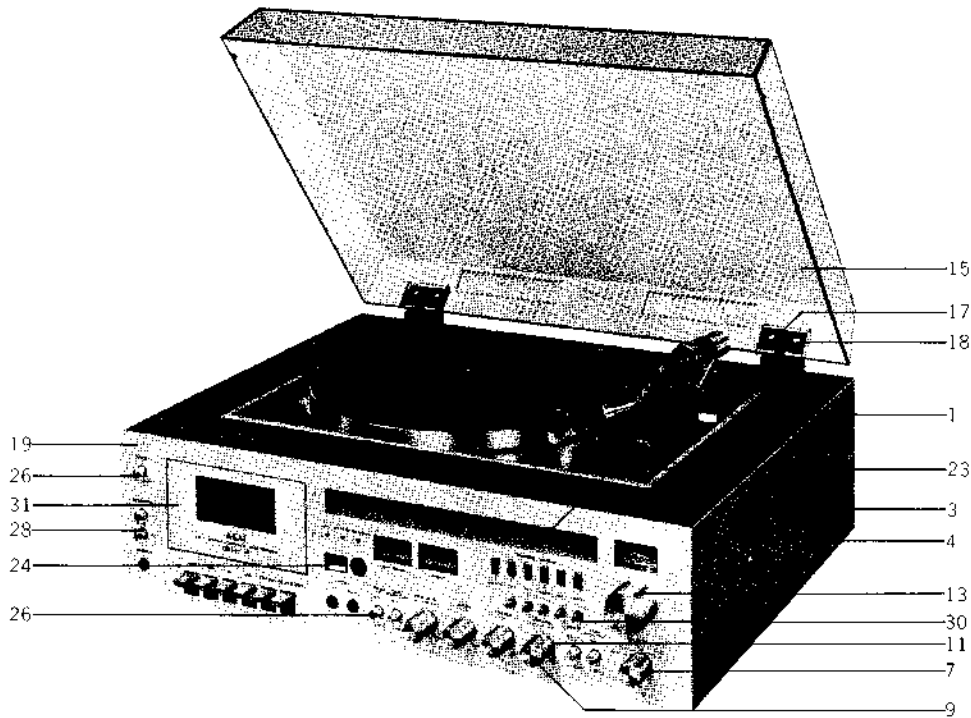

13) FINAL ASSEMBLY BLOCK

Ref. No.	Parts No.	Description	Schematic No.	Q'ty	Ref. No.	Parts No.	Description	Schematic No.	Q'ty
13-1	BC301509	Cabinet Part-G AC-3800	AC-3833	1	FRONT PANEL BLOCK				
13-2x	BC301560	Cabinet Part-G AC-3800-BL	AC-3833	1	13-19	BD304570	Front Panel Block Comp. AC-3800	AC-3860	1
13-3	ZW548010	Spot Facing Washer	MU-6028	4	13-20x	BD304572	Front Panel Block Comp. AC-3800L	AC-3860	1
13-4	ZS510344	Screw, binding head 4x12		4	13-21x	BD304573	Front Panel Block Comp. AC-3800BL	AC-3860	1
13-5x	TA301301	Cushion	AC-3843	8	13-22x	BD304574	Front Panel Block Comp. AC-3800L-BL	AC-3860	1
13-6x	ZS665550	Screw, pan head 4x15, w/washer		3	13-23	SP286558	Front Plate	AC-3535	1
13-7	SK646817	Single Knob	AA-5250	3	13-24	SE630156	Counter Escutcheon	CJ-6007	1
13-8x	SK281564	Single Knob (BL)	AA-5250	3	13-25x	ZG286435	Taper Spring	AC-3536	7
13-9	SK644670	Double Knob (Upper)	AA-5355	2	13-26	SK286367	Push Button Knob (A)	AC-3537	7
13-10x	SK287662	Double Knob (Upper) (BL)	AA-5355	2	13-27x	SK301304	Push Button Knob (C)	AC-3562	7
13-11	SK645208	Double Knob (Lower)	AA-5353	2	13-28	SE286547	Button Escutcheon (A)	AC-3538	3.5
13-12x	SK287673	Double Knob (Lower) (BL)	AA-5353	2	13-29x	ZW273756	Nut M3, #1		2
13-13	SK223705	Tuning Knob	T2-5019	1	13-30	SE631585	Button Escutcheon D	CG-6814	5
13-14x	SK267445	Tuning Knob (BL)	T2-5019	1	13-31	BD305100	Lid Panel Part-G AC-3800	AC-3860	1
13-15	BC301503	Dust Cover AC-3800	AC-3834	1	13-32x	BD305101	Lid Panel Part-G AC-3800L	AC-3860	1
13-16x	TP301300	Cover Cushion	AC-3842	2	13-33x	BD305102	Lid Panel Part-G AC-3800-BL	AC-3860	1
13-17	TP300758	Lock Plate	9-4-3	2	13-34x	BD305103	Lid Panel Part-G AC-3800L-BL	AC-3860	1
13-18	ZS301580	Screw, oval countersunk head 4x8		4					

14. LIST OF INTERCHANGEABLE SEMICONDUCTORS

As far as service is concerned, in case the original parts cannot be obtained, the interchangeable parts listed below can be substituted.

Original Parts			Interchangeable Parts	
Description	Parts No.	Utilizing P.C Board	Description	Parts No.
LA3350S	EI650597	AC-3801A		
HA-1197	EI299700	AC-3801A		
LA3122S	EI697871	AC-3801A		
NE545B	EI605013	AC-3501A		
STK-078	EI299608	AC-3504		
TA7303P	EI299441	AC-3801A		
LB1500	EI303086	AC-3803		
LB1515	EI300182	AC-3803		
2SA733 (Q) (P)	ET554657	AC-3503	2SA564 (Q) (R) 2SA628 (E) (F)	ET538154 ET557976
2SB544MP (E) (F)	ET299531	AC-3503		
2SC930 (E) (F)	ET618873	AC-3801A	2SC454 (B) (C) 2SC710 (D)	ET591366 ET704002
2SC945L (Q) (P)	ET639437	AC-3801A/3501A/3503	2SC536 (F) (G) (H) 2SC711 (E) (F) (G) (H)	ET634893 ET619727
2SC1449 (K) (L)	ET649034	AC-3503	2SD234 (O) (Y) 2SD313 (E) (F)	ET393568 ET452531
2SC1571NP (G) (H)	ET223446	AC-3501A	2SC1222 (E) (F) 2SC1312 (G) (H)	ET459810 ET517263
2SD313 (E) (F)	ET452531	AC-3503	2SD234 (O) (Y) 2SC1449 (K) (L)	ET393568 ET640034
2SD400MP (E) (F)	ET299507	AC-3503		
1S188AM	ED562386	AC-3501A	1N34A 1N60	ED219464 ED428264
1S2473	ED624903	AC-3801A	1S1588 1S2473VE	ED557447 ED560913
1S2473VE	ED560913	AC-3503	1S1588 1S2473	ED557447 ED624903
10DI	ED224526	AC-3503		
GP20G	ED245417	AC-3503		
RD-16E (C)	ED290722	AC-3503		
RE-9-1E (D)	ED300269	AC-3503		
SR-105D	ED698826	AC-3501B		
GL-3PG1	ED283138	AC-3501B		
SEL-103W	ED653624	AC-3802		

INDEX

Parts No.	Ref. No. & Symbol No.	Parts No.	Ref. No. & Symbol No.	Parts No.	Ref. No. & Symbol No.	Parts No.	Ref. No. & Symbol No.	Parts No.	Ref. No. & Symbol No.
BA290632	3-1	EC523282	3-C27	EO539820	4-L1	ML721541	2-47	TP740365	9-5
BA290654	11-90	EC604440	3-C20	EO650428	4-L2,3	ML721642	2-54	TP740366	9-6
BA300187	8-1	EC616342	4-TC1,2	EO650823	6-L1	ML721653	2-55	TP740367	9-7
BA300358	11-95	EC621257	3-C12	EP740395	2-94	ML721675	2-57	TP740368	9-10
BA300361	7-1	EC621257	3-C38	ER246363	11-92x	ML721686	2-58	TP740369	10-7
BA300364	11-99	EC638177	3-C15	ER300744	11-48x	ML721708	2-59	TP740372	9-11
BA300702	4-1	EC650406	4-C53	ER300744	11-85x	ML721743	2-63	TP740373	9-19
BA300703	4-2	EC675742	4-TC1,2	ER303699	5-R4	ML723082	2-20	TP740374	9-16
BA300961	5-1	EC676721	3-C1	ER650430	4-FL1,2	ML740392	2-56	TP740377	9-21
BA300963	5-2	EC684720	11-9	ER669734	3-FL1	MR530651	11-17	TP740378	9-22
BA300971	5-3	EC684720	5-C1	ES224436	11-6	MR530662	11-18	TP740381	9-25
BA300974	12-1	EC684720	5-C2	ES239218	11-7x	MR740390	2-43	TP740383	9-27
BA301497	6-1	EC684720	5-C26,27	ES242346	11-8x	MS300639	11-50	TP740388	10-16
BA301498	6-2	EC684720	5-C3to6	ES246227	12-2	MS715555	9-13	TP740389	10-17x
BA301499	6-3	EC709920	10-22	ES299294	11-104	MS720990	2-5	TP740402	10-18
BA301614	11-100x	EC720101	10-23x	ES299294	3-SW4,5	MS721710	2-60	TP740403	10-19
BA301615	8-2	ED224526	11-14x	ES299327	11-103	MT721530	2-46	TP740404	9-32
BA304296	11-86	ED224526	5-D15,16	ES299327	3-SW1,2	MV357208	2-122	TP740405	9-33
BA722496	2-124	ED224526	5-D5to10	ES299362	3-SW3	MV666887	2-123	TP740408	9-35
BC301503	13-15	ED245417	5-D1to4	ES300760	11-110x	MV715307	9-38	TP740409	9-37
BC301509	13-1	ED283138	11-88	ES300761	4-SW1	MV719133	9-1	TP740413	9-41
BC301560	13-2x	ED290722	5-D11	ES300761	11-109	MV740371	10-9	TP740414	9-42
BD304570	13-19	ED300184	8-D1	ES300761	4-SW1	MV740385	9-30	ZG286435	13-25x
BD304572	13-20x	ED300269	5-D11	ES592964	11-33	MZ721631	2-53	ZG300739	11-30
BD304573	13-21x	ED300269	5-D14	ES698927	11-91	SA301770	11-42	ZG431897	11-34
BD304574	13-22x	ED560913	5-D12	ES709817	10-26	SB721247	2-27	ZG715465	10-12
BD305100	13-31	ED562386	3-D1to3	ES718648	10-27x	SB721258	2-28	ZG715577	9-15
BD305101	13-32x	ED624903	4-D1	ES721484	2-41	SB743467	2-29x	ZG715814	9-20
BD305102	13-33x	ED624903	7-D1	ES722070	2-95	SB743470	2-30x	ZG717827	2-9
BD305103	13-34x	ED653624	11-101x	ES740342	2-125	SE286547	13-28	ZG719403	9-23
BD719414	10-11	ED698826	11-87	ET223446	3-TR1to3	SE630156	13-24	ZG720988	2-4
BF701100	2-21	EE298337	12-19	ET223446	3-TR6,7	SE631585	13-30	ZG721102	2-78
BH720966	2-2x	EE299621	12-18	ET299507	5-TR8	SK223705	13-13	ZG721361	2-82
BK700301	2-23	EE300181	11-96	ET299531	5-TR7	SK267445	13-14x	ZG721372	2-83
BK740391	2-24x	EE300785	11-108	ET452531	5-TR3	SK281564	13-8x	ZG721383	2-84
BL719256	9-12	EE300785	4-3	ET554657	5-TR4	SK286367	13-26	ZG721563	2-88
BL719370	10-10	EF300580	11-78x	ET618873	4-TR1	SK287662	13-10x	ZG721855	2-69
BL720347	2-22	EF563657	11-77	ET639437	3-TR4,5	SK287673	13-12x	ZG721866	2-70
BL721113	2-14	EF563681	11-75x	ET639437	4-TR2,3	SK301304	13-27x	ZG721877	2-71
BL721282	2-33	EF563703	11-71	ET639437	4-TR4	SK644670	13-9	ZG721888	2-72
BL721293	2-34	EF563703	11-73x	ET639437	5-TR2	SK645208	13-11	ZG721890	2-73
BL721405	2-38	EF590692	11-72x	ET639437	5-TR5,6	SK646817	13-7	ZG721901	2-74
BL721517	2-44	EF602550	11-59x	ET649034	5-TR1	SK652397	12-13	ZG721912	2-75
BL721528	2-45	EF623103	11-74x	EV229915	11-113	SK740375	9-17	ZG721934	2-77
BM701335	2-93	EF623103	11-76x	EV229915	8-VR1to5	SK740380	9-24	ZG721945	2-79
BM740386	10-14	EI299441	4-IC2	EV288437	11-114x	SL719155	10-6	ZG721956	2-80
BM740387	10-15x	EI299608	11-112	EV288437	8-VR1to5	SP286558	13-23	ZG721967	2-81
BR700986	2-19	EI299608	6-IC1	EV299338	11-105	SP300656	11-41	ZG721978	2-85
BT293398	4-T4	EI299700	4-IC4	EV299338	3-VR2	SP300657	11-62	ZG721980	2-86
BT294131	11-23x	EI300182	7-IC2	EV299340	11-107	SP300659	11-1	ZG722002	2-88
BT299575	4-T1	EI303086	7-IC1	EV299340	3-VR6,7	SP300665	12-5	ZG722013	2-89
BT304318	11-22x	EI303086	7-IC3	EV299351	11-106	SP300667	12-6x	ZG722024	2-90
BT650384	4-T5	EI605013	3-IC1	EV299351	3-VR5	SP300670	12-7	ZG722035	2-91
BT698804	11-21	EI650597	4-IC3	EV464207	4-VR2,3	SP300671	12-8x	ZG722035	2-91
BZ700290	2-31x	EI697871	4-IC1	EV464231	5-VR1,2	TA207347	11-56	ZG723115	2-87
BZ720955	2-1	EJ207854	4-P1	EV478686	4-VR1	TA286525	11-67	ZG740359	10-1
BZ721001	2-6	EJ225022	11-93	EV520806	3-VR3,4	TA286536	11-69	ZG740360	10-2
BZ721124	2-15	EJ240581	12-15	EV522797	11-97x	TA286626	11-16	ZG740361	10-3
BZ721146	2-17	EJ254970	11-60	EV522797	3-VR1	TA286626	11-16	ZG740362	10-4
BZ721157	2-18	EJ283094	4-J1	EW374894	12-28	TA300418	11-58	ZG740379	10-13
BZ721260	2-32	EJ293646	12-9	EW740411	10-24	TA300423	11-54	ZG740384	9-28
BZ721348	2-35	EJ296853	12-29	EW740412	10-29	TA301140	11-63	ZG740393	2-76
BZ721350	2-36	EJ299283	11-102	EZ631945	12-26	TA301141	11-65x	ZG740394	2-92
BZ721440	2-39	EJ299283	3-J1,2	HE721056	2-8	TA301301	13-5x	ZG740406	9-34
BZ721495	2-42	EJ539447	11-39	HP721045	2-7	TA301310	11-68x	ZS300421	11-55
EA740410	10-21	EJ551035	11-26	HZ723060	2-3	TA301311	11-70x	ZS300425	11-15x
EC214558	4-C35	EJ740349	10-28	MB701111	2-49	TA301312	11-64x	ZS301580	13-18
EC215065	4-C37	EL283184	11-89	MB701122	2-50	TA301313	11-66x	ZS302024	11-36
EC219936	11-111	EL300186	11-98	MB701370	2-67	TA530910	12-20	ZS323728	2-103
EC219936	5-C7.8	EM300759	11-81	MB701381	2-68	TA625847	12-21	ZS325495	11-2
EC220421	5-C10	EM301306	11-80x	MB719008	9-31	TA646773	11-53	ZS325495	5-4
EC294118	11-10x	EM301315	11-82x	MB721607	2-51	TC721473	2-40	ZS325495	6-5
EC298563	12-4x	EM698815	11-79	MB721798	2-66	TC721721	2-61	ZS355522	12-12
EC299395	3-C4	EO263068	11-13	MC701368	2-65	TP300758	13-17	ZS369900	10-5
EC299553	12-3x	EO290744	5-T1	MH740401	2-117	TP301300	13-16x	ZS379350	11-5
EC301320	11-11x	EO293387	4-T2	ML300419	11-20	TP709503	9-36	ZS379350	3-2
EC301320	11-12x	EO299373	3-L2	ML286457	11-27	TP719098	9-8	ZS417216	11-47
EC516767	6-C2	EO299384	3-L1	ML286470	11-32	TP719100	9-9	ZS417216	11-94
EC520773	5-C21	EO299564	4-T3	ML286604	11-28	TP719267	9-14	ZS421806	11-57
EC523282	3-C21	EO350796	8-L1	ML290902	11-31	TP740363	9-3	ZS434250	10-20
						TP740364	9-4	ZS434250	11-44x

INDEX

Parts No.	Ref. No. & Symbol No.	Parts No.	Ref. No. & Symbol No.	Parts No.	Ref. No. & Symbol No.	Parts No.	Ref. No. & Symbol No.	Parts No.	Ref. No. & Symbol No.
ZS447761	11-3x								
ZS447761	12-27								
ZS447840	11-61x								
ZS460440	2-26x								
ZS462802	6-4								
ZS463353	12-30								
ZS498273	12-11								
ZS510344	13-4								
ZS521943	2-96								
ZS522865	12-16								
ZS523664	11-40								
ZS530673	11-19								
ZS552600	12-22								
ZS565942	11-43								
ZS608106	2-12								
ZS608185	12-17								
ZS608185	2-98								
ZS665550	13-6x								
ZS666336	11-84x								
ZS711887	10-25								
ZS712091	10-30								
ZS712091	9-2								
ZS721091	2-13								
ZS721394	2-104								
ZS721620	2-52								
ZS721732	2-62								
ZS721765	2-64								
ZS722081	2-11								
ZS722092	2-37								
ZS722103	2-97								
ZS722114	2-99								
ZS722125	2-100								
ZS722136	2-102								
ZS740376	9-18								
ZS740396	2-101								
ZW270088	11-35x								
ZW270101	2-25								
ZW270112	2-119								
ZW270123	11-51								
ZW273756	13-29x								
ZW273767	12-10								
ZW273881	11-46x								
ZW273914	11-24								
ZW273914	12-25								
ZW290283	11-29								
ZW322110	11-52								
ZW356657	2-118								
ZW358018	2-10								
ZW410051	2-121								
ZW413188	11-25								
ZW413188	11-45x								
ZW420682	12-24								
ZW548010	13-3								
ZW562476	11-83x								
ZW604416	12-23								
ZW623283	2-120								
ZW652408	12-14								
ZW698308	11-4								
ZW698940	11-49x								
ZW700380	2-115x								
ZW715612	9-29								
ZW719043	9-39								
ZW719054	9-40								
ZW721135	2-112x								
ZW721135	2-16								
ZW721181	2-113								
ZW722171	2-107								
ZW722182	2-108								
ZW722193	2-109								
ZW722204	2-110								
ZW722215	2-111								
ZW740370	10-8								
ZW740382	9-26								
ZW740397	2-105								
ZW740398	2-106								
ZW740399	2-114x								
ZW740400	2-116								

SECTION 3

SCHEMATIC DIAGRAM

1. AC-3800/L NO. 4-1 1542220A BLOCK DIAGRAM
2. AC-3800/L NO. 4-2 1542221A TONE CONTROL SCHEMATIC DIAGRAM
3. AC-3800 NO. 4-3 1542222A MULTI FUNCTION SCHEMATIC DIAGRAM
4. AC-3800L NO. 4-4 1542223A MULTI FUNCTION SCHEMATIC DIAGRAM

AC-3800/L

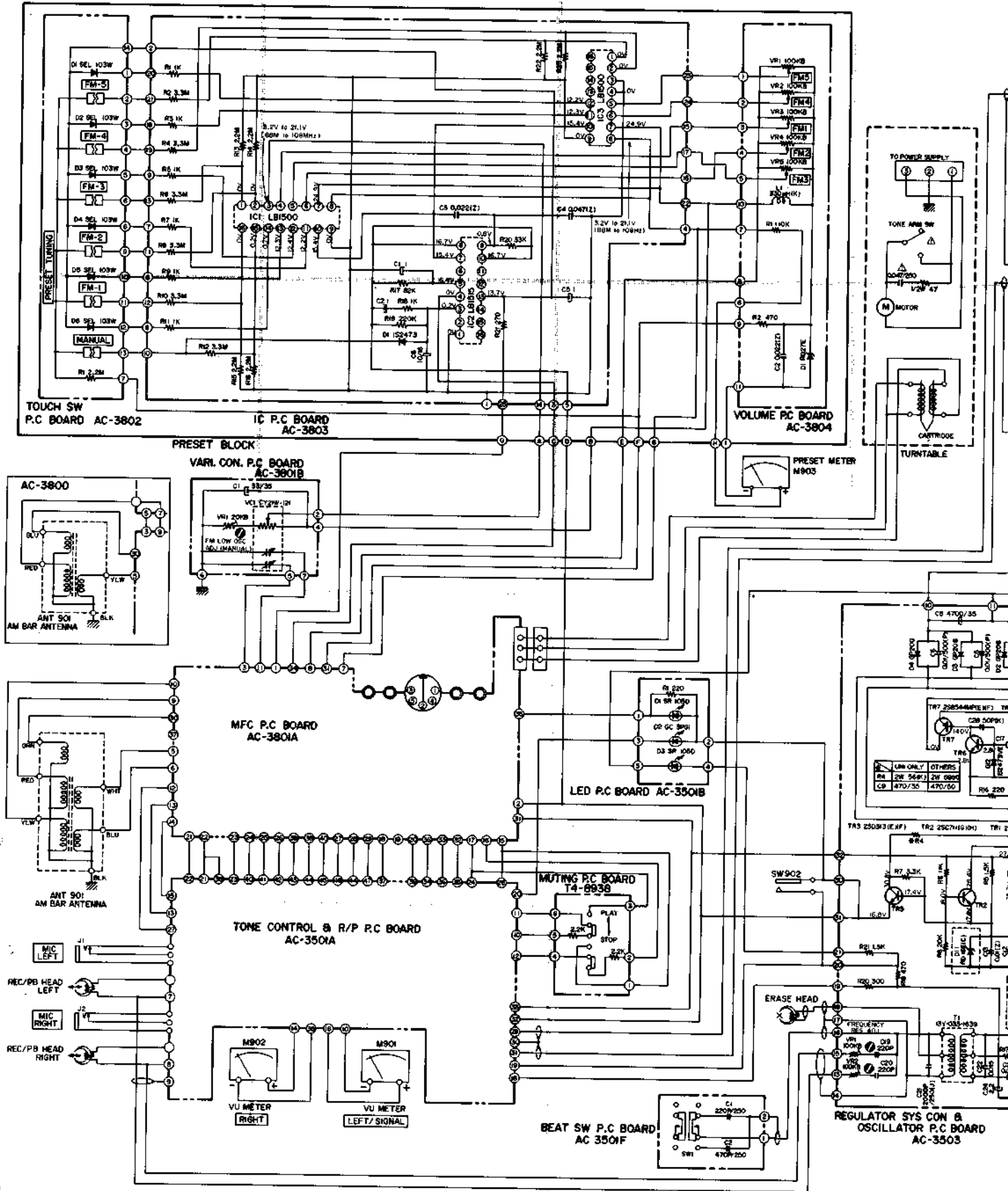

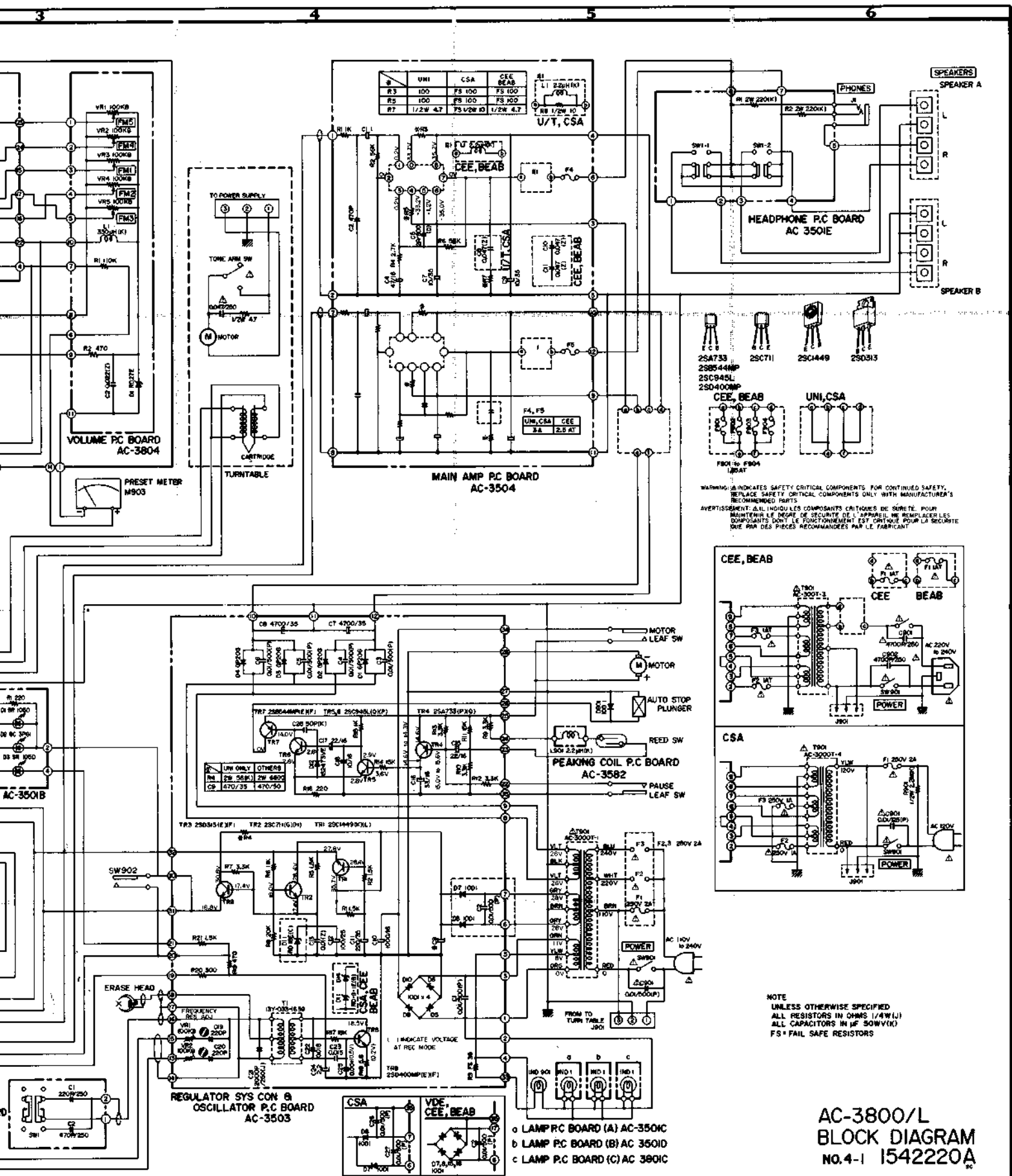

AC-3800/L

LEFT

REC/PB HEAD HN424549

REC/PB HEAD HN424549

RIGHT

TR1, TR2, TR3
2SC1871NP (G11H)

IC1 NE5456
FL1 F81801M

P.B. REC.

TR6, TR7
2SC1871NP (G11H)

BASS

TREBLE

MONITOR

MODE

VOLUME

REC LEVEL

DOLBY NR

A

B

C

D

000958

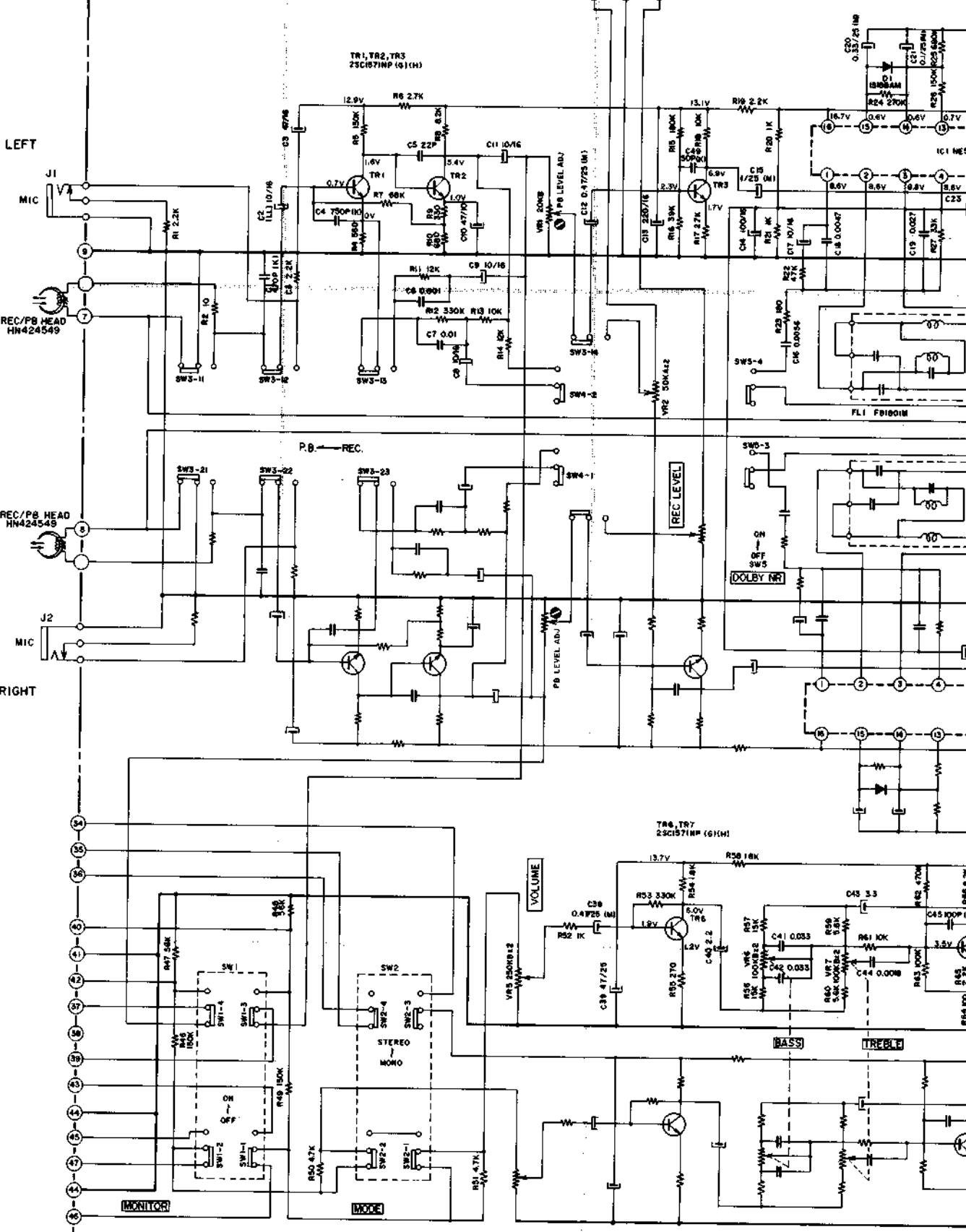

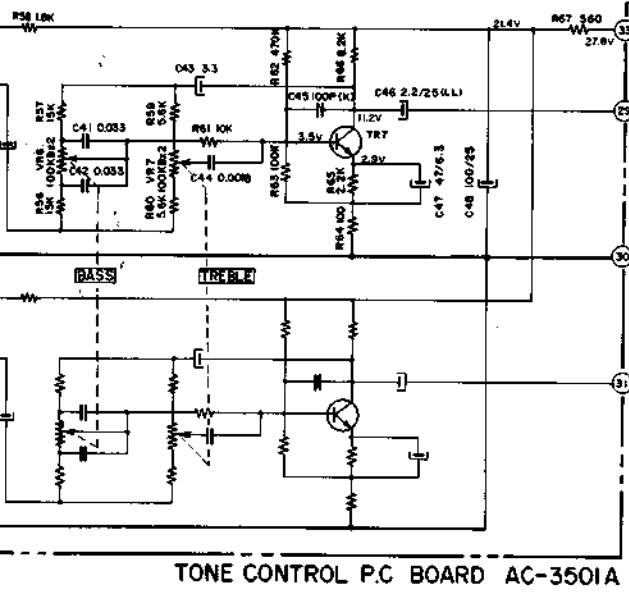
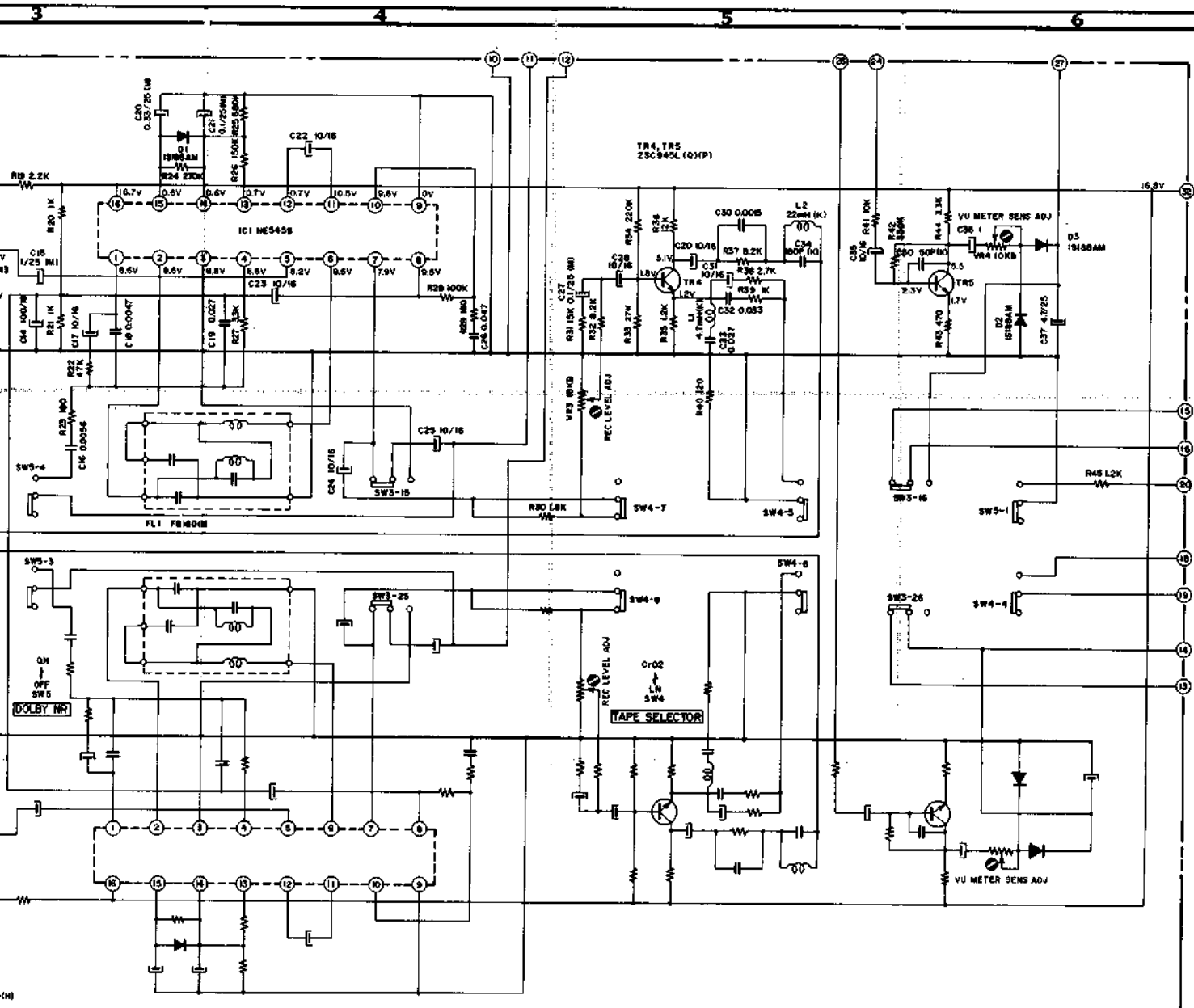

- SW1.1to4 TAPE MONITOR OFF POSITION
- SW2.1to4 MODE MONO POSITION
- SW3.1to6,21to26 REC/PB PB POSITION
- SW4.1to8 TAPE SELECTOR LN POSITION
- SW5.1to4 DOLBY NR OFF POSITION

NOTE
UNLESS OTHERWISE SPECIFIED
ALL RESISTORS IN OHMS (1/4W U)
ALL CAPACITORS IN μ F 50WV(U)
LL = LOW LEAKAGE CAPACITORS

AC-3800/L
TONE CONTROL
SCHEMATIC DIAGRAM
NO.4-2 1542221A
20

AC-3800

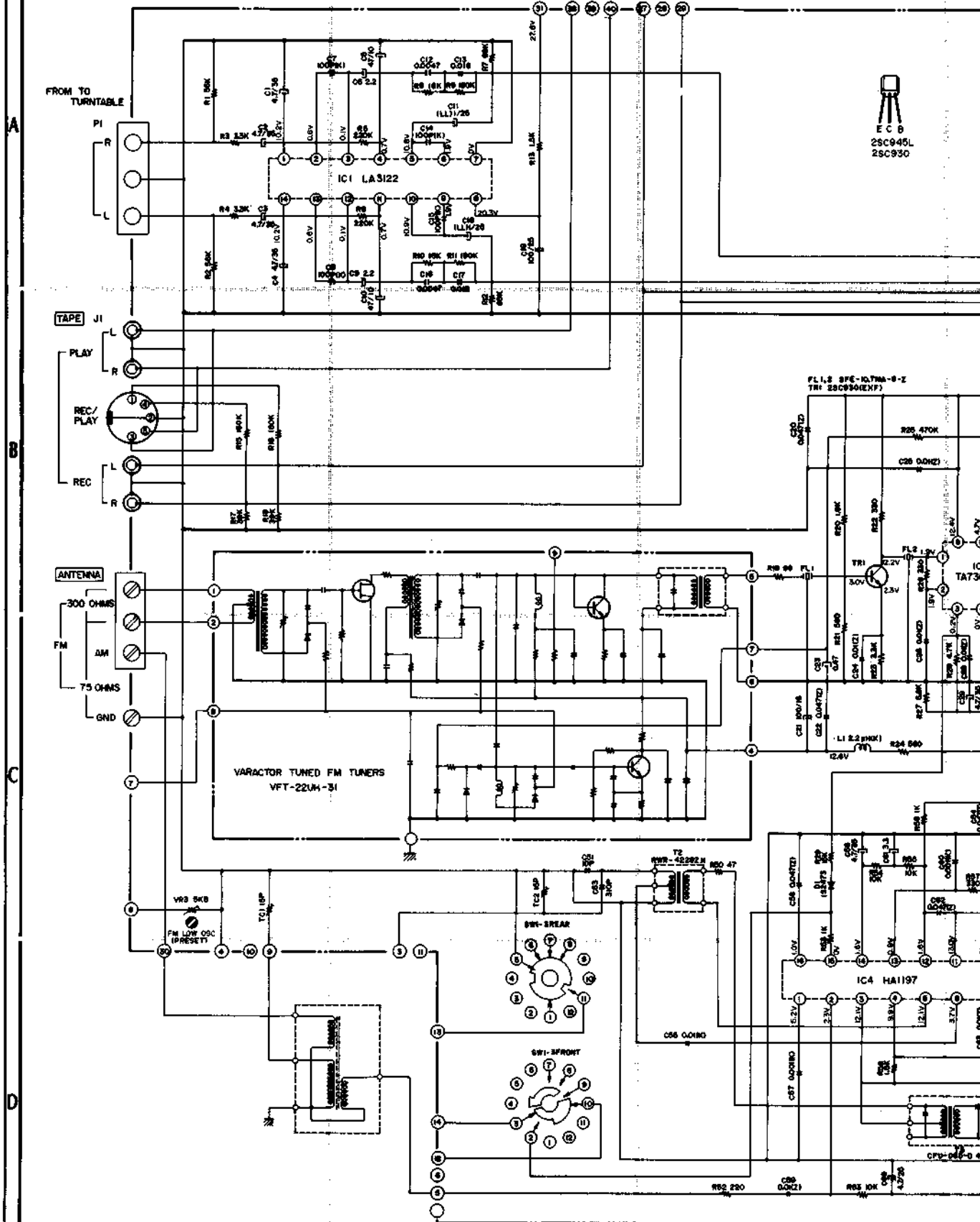

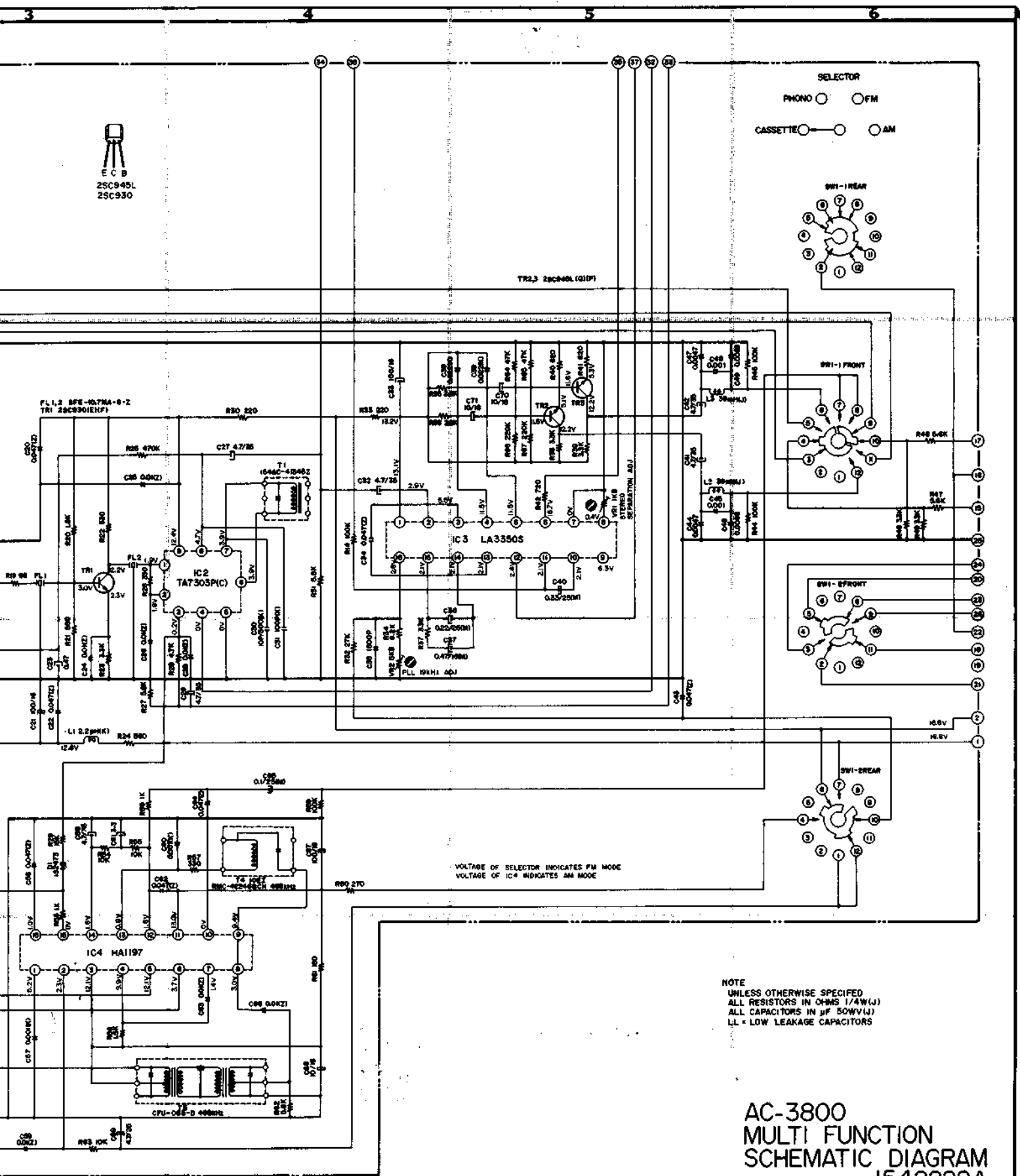

C C B
 25C945L
 25C930

SELECTOR
 PHONO ○ ○ FM
 CASSETTE ○ ○ AM

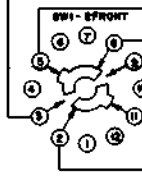
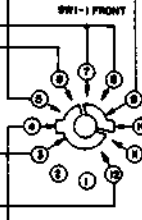
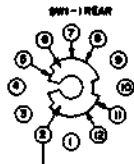

TR2,3 28C46L (Q1P)

FL1,2 BFE-107MA-0-2
 TR1 28C930(IEP)

VOLTAGE OF SELECTOR INDICATES FM MODE
 VOLTAGE OF IC4 INDICATES AM MODE

NOTE
 UNLESS OTHERWISE SPECIFIED
 ALL RESISTORS IN OHMS 1/4W(1/2)
 ALL CAPACITORS IN uF 50WV(1/2)
 LL = LOW LEAKAGE CAPACITORS

AC-3800
 MULTI FUNCTION
 SCHEMATIC DIAGRAM
 No.4-3 1542222A
 2C

AC-3800L

FROM TO
TURNTABLE

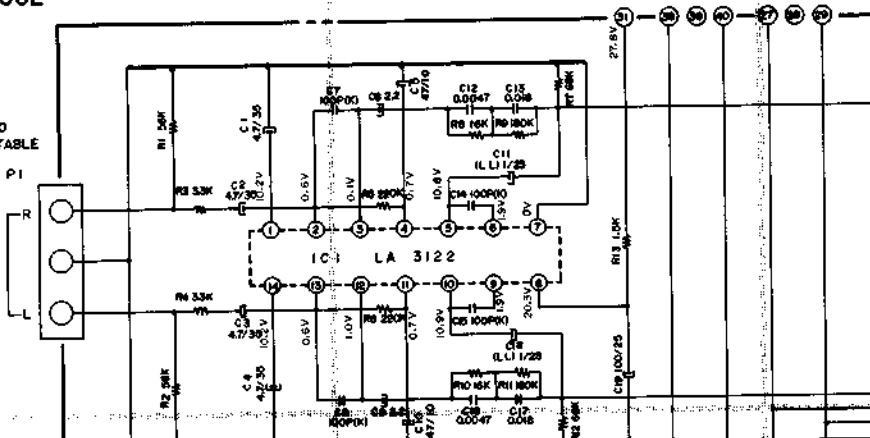

TAPE

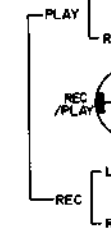

ANTENNA

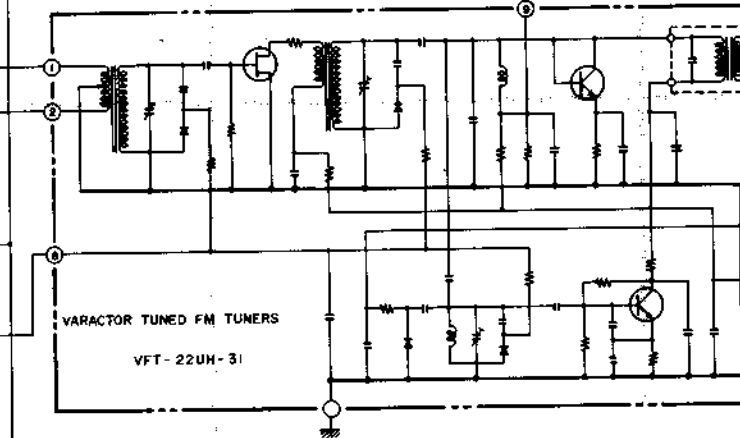
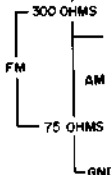

TC1 ISP

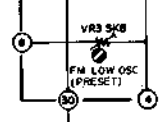

SW1-FRONT



SW1-SNEAR



TC2 ISP



SW1-REAR



SW1-4 FRONT



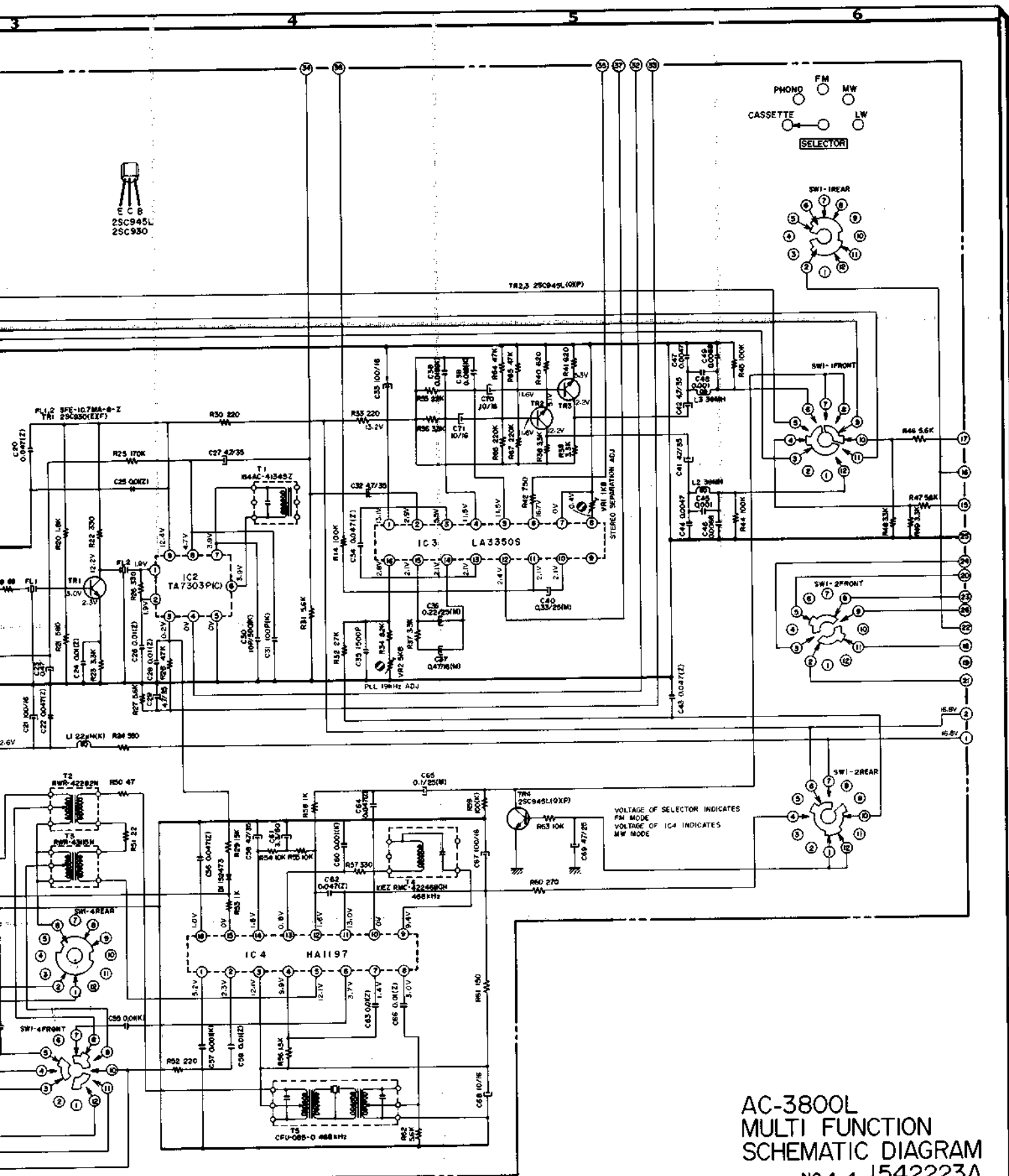

AC-3800L
 MULTI FUNCTION
 SCHEMATIC DIAGRAM
 NO.4-4 1542223A
 PC