

AC-400
AC-405K
SR-400

AKAI SERVICE MANUAL

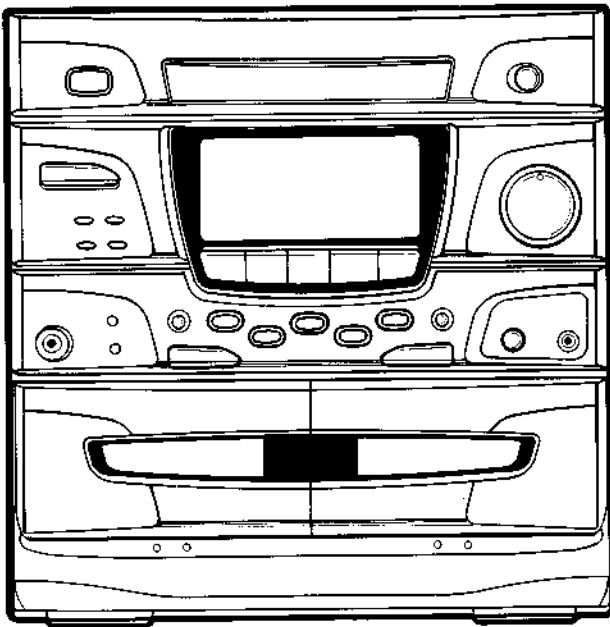

AC-400

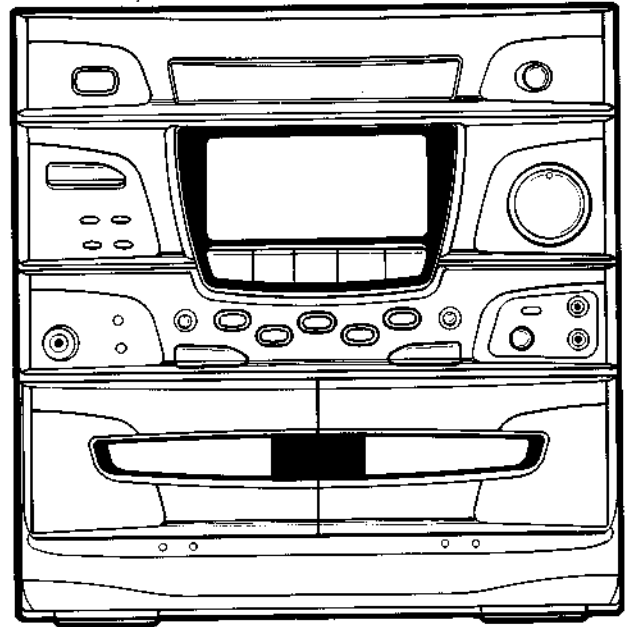

AC-405K

MINI COMPONENT SYSTEM

AC-400/AC-405K
SR-400

CONTENTS

[AC-400 / AC-405K]

SAFETY INSTRUCTIONS	4
INFORMATIONS	5
SPECIFICATIONS	6
I. DISASSEMBLY	8
II. PRINCIPAL PARTS LOCATIONS	9
III. REPLACEMENT OF PRINCIPAL MECHANICAL PARTS	11
IV. ADJUSTMENT	15
V. PARTS LIST	19
VI. WIRING DIAGRAM	33
VII. BLOCK DIAGRAM	34
VIII. SCHEMATIC DIAGRAM	38
IX. PCB LAYOUT	45
X. INFORMATION OF ICs MI-COM	51
ABBREVIATIONS	60

[SR-400]

SPECIFICATIONS	64
SCHEMATIC DIAGRAM	64
PARTS LIST	65

SAFETY INSTRUCTIONS

PRECAUTIONS DURING SERVICING

1. Parts indentified by the Δ (*) symbol parts are critical for safety. Replace them only with parts whose numbers are specified.
2. In addition to safety, other parts and assemblies are specified for conformance with such regulations as those applying to spurious radiation. These must also be replaced only with specified replacements.
Examples: RF converters, tuner units, antenna selection switches, RF cables, noise-blocking capacitors, noise-blocking filters, etc.
3. Use specified internal wiring. Note especially:
 - 1) Wires covered with PVC tubing
 - 2) Double insulated wires
 - 3) High voltage leads
4. Use specified insulating materials for hazardous live parts. Note especially:
 - 1) Insulating Tape
 - 2) PVC tubing
 - 3) Spacers (insulating barriers)
 - 4) Insulating sheets for transistors
 - 5) Plastic screws for fixing micro switches
5. When replacing AC primary side components (transformers, power cords, noise blocking capacitors, etc.), wrap ends of wires securely about the terminals before soldering.

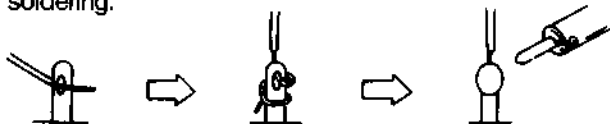

6. Make sure that wires do not contact heat generating parts (heat sinks, oxide metal film resistors, fusible resistors, etc.).
7. Check if replaced wires do not contact sharply edged or pointed parts.
8. Also check areas surrounding repaired parts.
9. Make sure that foreign objects (screws, solder droplets, etc.) do not remain inside the set.

MAKE YOUR CONTRIBUTION TO PROTECT THE ENVIRONMENT

Used batteries with the ISO symbol for recycling as well as small accumulators (rechargeable batteries), mini-batteries (cells) and starter batteries should not be thrown into the garbage can.



Please leave them at an appropriate depot. All other household batteries can be thrown out with the household waste.

SAFETY CHECK AFTER SERVICING

After servicing, make measurements of leakage-current or resistance in order to check if exposed parts are acceptably insulated from the supply circuit.

The leakage-current measurement should be done between accessible metal parts (such as chassis, ground terminal, microphone jacks, signal input/output connectors, etc.) and the earth ground through a resistor of 1500 ohms paralleled with a 0.15 μ F capacitor, under the unit's normal working condition.

The leakage-current should be less than 0.5mA rms AC. The resistance measurement should be done between accessible exposed metal parts and power cord plug prongs with the power switch "ON" (if included). The resistance should be more than 2.2Mohms.

PRECAUTIONS IN REPAIRING

When repairing or adjusting the unit, please note the following points.

1. Do not put excessive pressure on the mechanical part (operation part), including the pick-up block, as extremely high mechanical precision is required in these parts.
2. When the base is removed for repair or adjustment, make sure that there are no metal objects between the PC board or the mecha parts and the base.
3. The Micro-Computer and the CD signal processing ICs may be damaged by static electricity or leakage from a soldering iron during repairing. While soldering, please take the precautions against leakage as in the illustration.

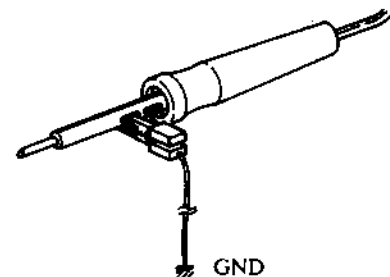

4. Do not loosen any screws in the pick-up block. Please refer to NOTE when replacing the pick up block.
5. To avoid hazardous invisible Laser Radiation, DO NOT look at the Laser Beam (Objective lens) directly.
6. On models for some countries, laser warning labels are affixed on and inside of the unit, as shown below. For your safety, read these labels carefully before repairing or adjusting the unit.

CAUTION

The use of controls or adjustments or the performance of procedures other than those specified herein may result in hazardous radiation.

[EUROPE, SCANDINAVIA, UK and AUSTRALIA]

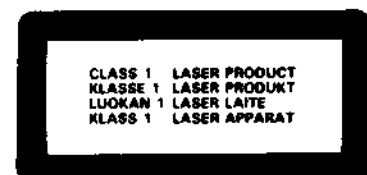

Label affixed on the rear panel of the unit

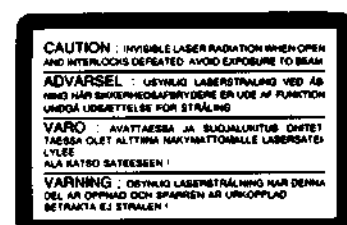

Label affixed on the CD MECHA chassis

INFORMATIONS

SYMBOLS FOR PRIMARY DESTINATION

Alphabet indicates the destination of the units as listed below.

Symbol	Principal Destination
A	USA
B	UK
E	Europe(except, UK)
S	Australia
V	Germany
U	Universal
Y*	Custom version

VOLTAGE CONVERSION (U Y Model only)

Before connecting the power cord, set the VOLTAGE SELECTOR located on the rear panel of the AC-400/AC-405K so that the correct voltage for your area is indicated.

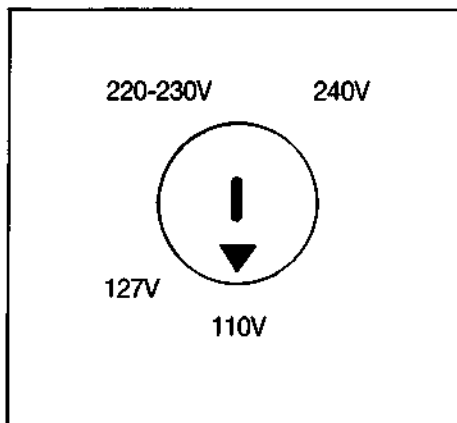

[U, Y]

SPECIFICATIONS

[AMPLIFIER Section]

Power output	30W+30W(6 ohm, 1KHz, 10% THD, EIAJ) 25W+25W(6 ohm, 1KHz, 1% THD, DIN)
Total harmonic distortion	0.05%(-10dB for RMS)
Input sensitivity	
AUX	400mV/47K ohms
S/N ratio	
AUX	70dB
Channel separation	55dB

[Deck Section]

Track system	4 track, 2 channel system
Frequency response	100-12,500Hz \pm 3dB(Normal tape) 100-12,500Hz \pm 3dB(CrO ₂ tape)
Wow & Flutter	0.2%(WRMS)
S/N ratio(CCIR/ARM)	62dB(DOLBY ON, CrO ₂ tape) 52dB(DOLBY OFF, Normal tape)
Total harmonic distortion	1.0%(Normal tape, at 400Hz)
Channel separation	35dB

[General]

Power requirement

AC-400

E/V	AC 220-230V, 50Hz
B	AC 230V, 50Hz
S	AC 240V, 50Hz
U, Y	AC 110/127/220-230/240V, 50/60Hz convertible

AC-405K

U, Y	AC 110/127/220-230/240V, 50/60Hz convertible
------------	--

Dimension	270(W) \times 280(H) \times 371(D)mm
Weight	9Kg
Power consumption	88W

[Tuner Section]

Frequency range

FM	87.5-108MHz(50KHz step)
MW	531-1602KHz(9KHz step)
	[E / V / S / B / U ₅ / Y ₁ / Y ₃ / Y ₇]
	530-1610KHz(10KHz step)
	[U ₈ / Y ₂ / Y ₄]
LW	144-288KHz(1KHz step)
SW	3.8-12.5MHz(5KHz step)

Sensitivity

FM	3 μ V (IHF, THD 3%) [EXCEPT V]
	5 μ V (IHF, THD 3%) [V]
MW	700 μ V (IHF, THD 10%)
LW	1500 μ V (IHF, THD 10%)
SW	30 μ V (IHF, THD 10%)

S/N ratio(IHF A NETWORK)

FM	Mono:70dB
	Stereo:65dB
MW	40dB
LW	30dB
SW	30dB

Total Harmonic distortion(at 1KHz)

FM	Mono:0.8%
	Stereo:1.0%
MW	1.0%
LW	1.0%
SW	2.0%

Stereo separation 35dB(at 1KHz)

[Graphic Equalizer]

Center frequency 63Hz/160Hz/400Hz/1KHz/2.5KHz/6.3KHz/16KHz

Control range \pm 8dB(2dB step)**[CD Section]**

Pick up system 3 Beam laser

Sampling frequency 44.1KHz

Error correction system Cross interleave reed solomon

Number of channels 2 Channel

Frequency response 20Hz~20KHz

S/N ratio 90dB

Wow & flutter Below measurable limits

Total harmonic distortion 0.07% (at 1KHz)

Channel separation 85dB (at 1KHz)

Dynamic range 85dB (at 1KHz)

* For improvement purposes, specifications and design are subject to change without notice.

I. DISASSEMBLY

1. REMOVAL OF COVER-TOP

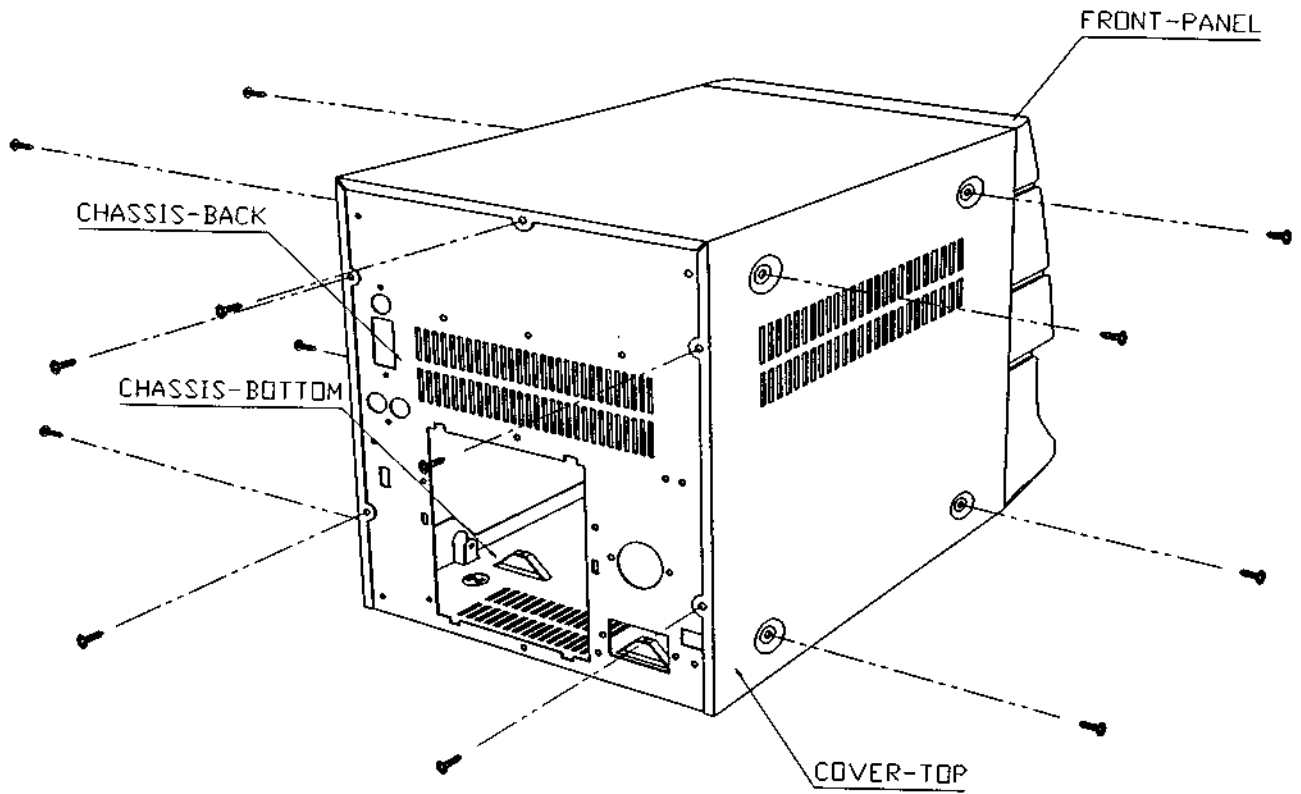

2. REMOVAL OF CD MECHA & CASSETTE DECK MAINTENANCE

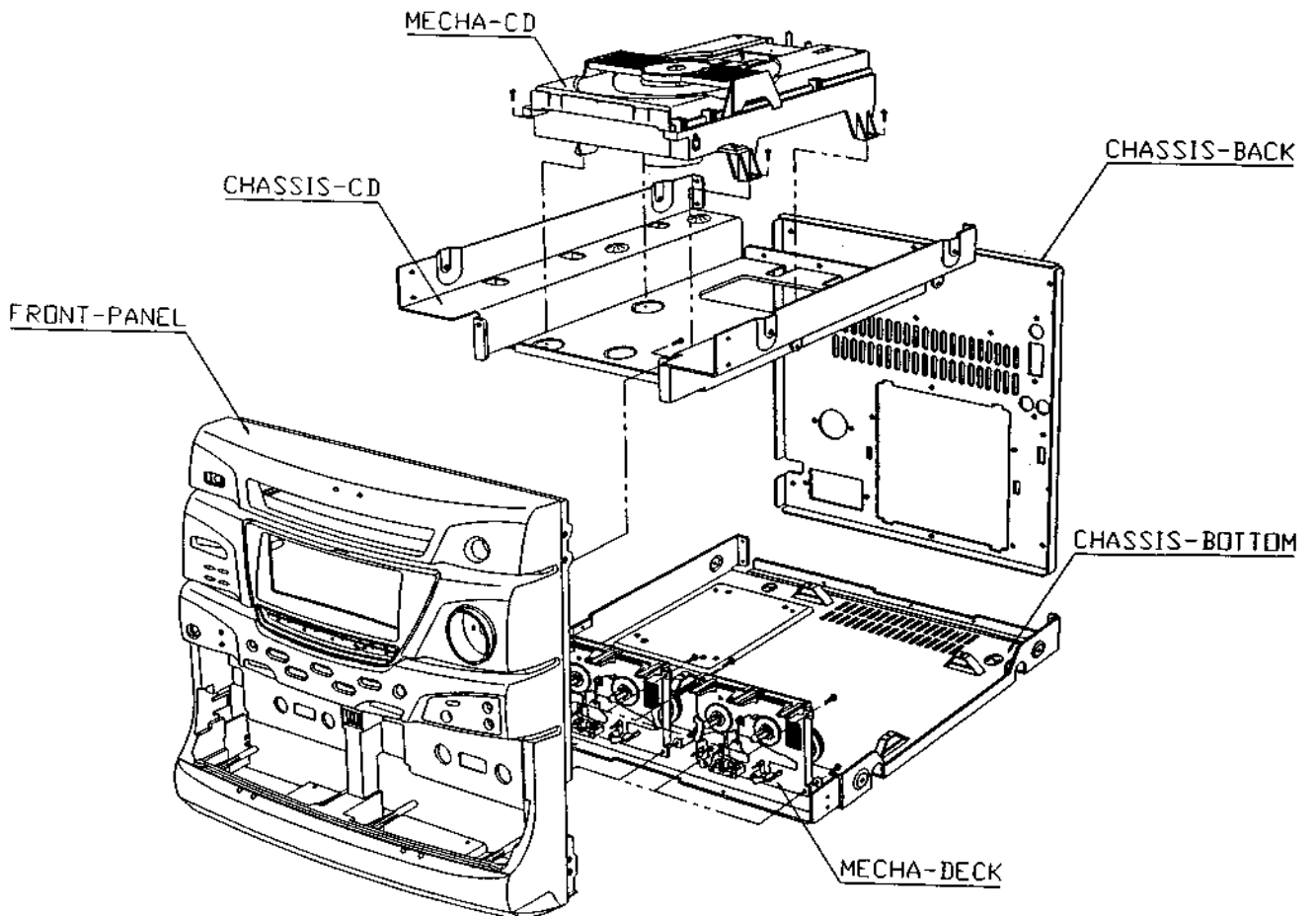

II. PRINCIPAL PARTS LOCATIONS

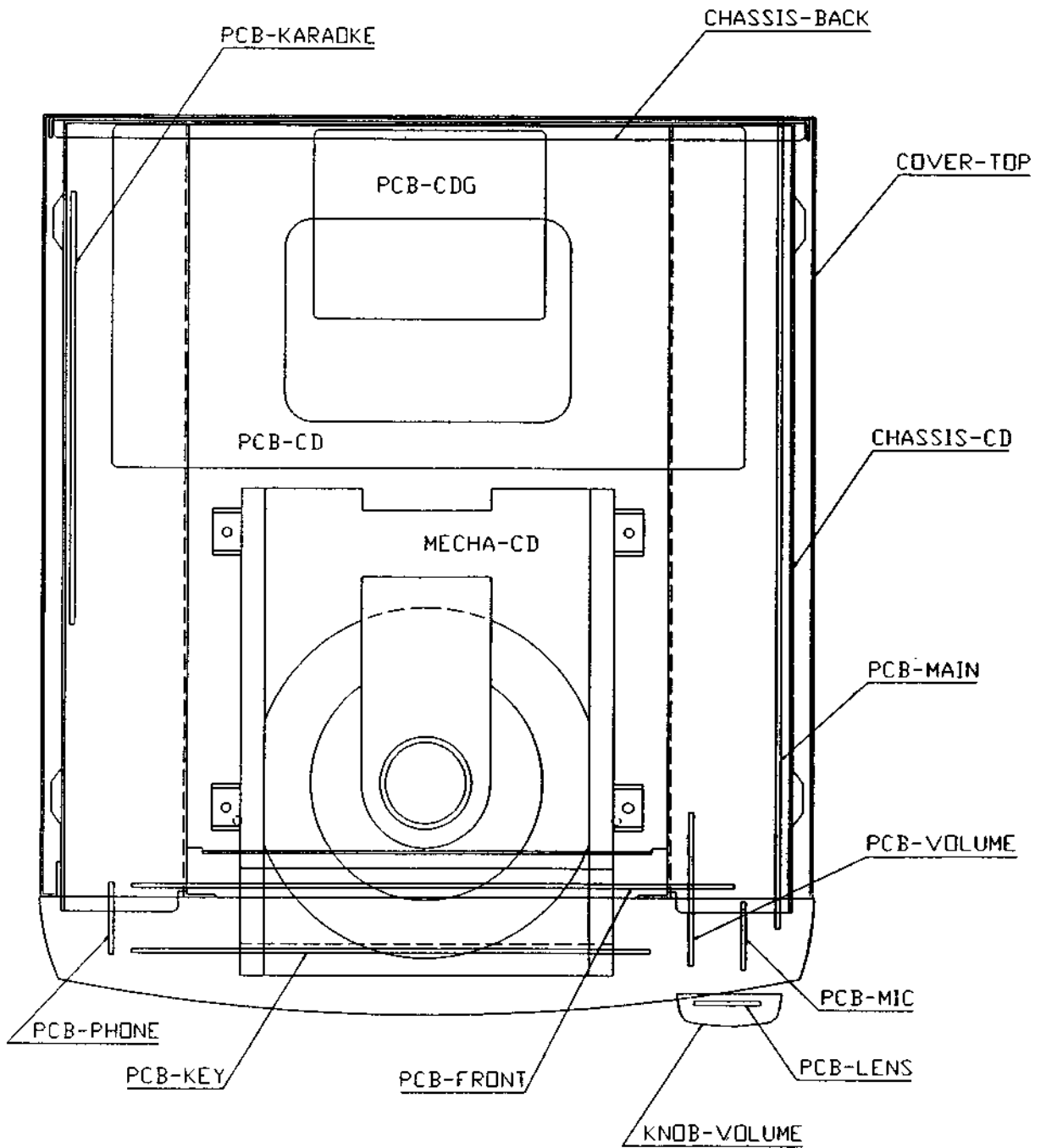

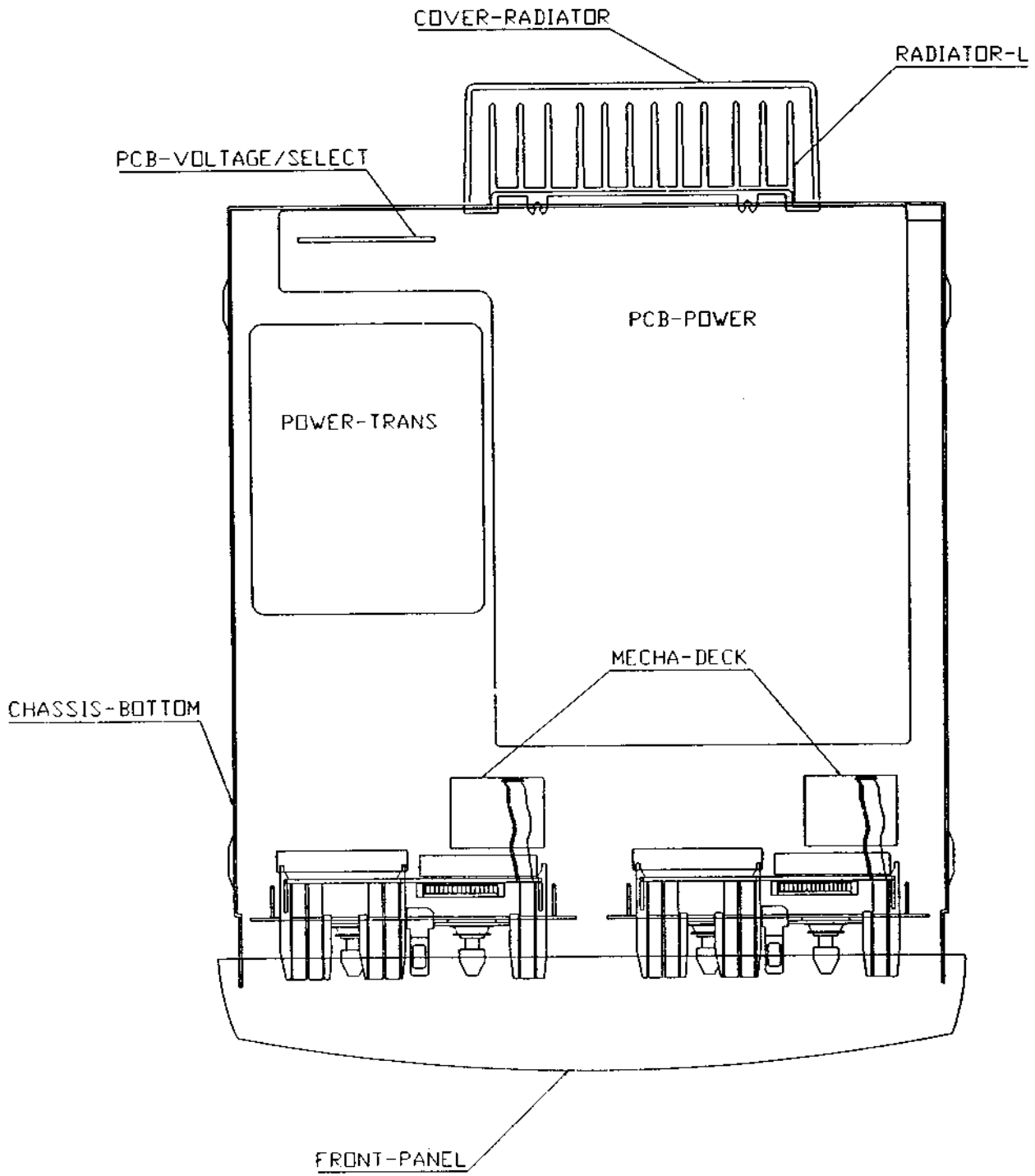

III. REPLACEMENT OF PRINCIPAL MECHANICAL PARTS

CD MECHANISM

1. DISMANTLING PROCEDURE OF THE COMPONENTS

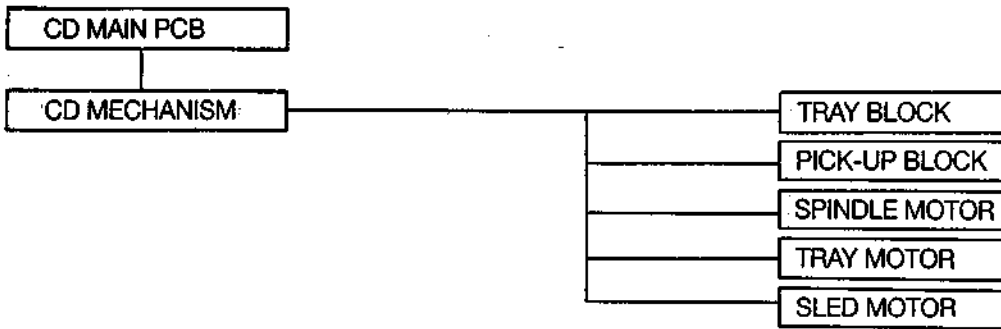

2. REMOVAL OF THE CD MAIN PCB

1) Disconnect the four connectors carefully (These are on the CD PCB. fig 1. CN601, CN602, CN605, CN606).

3. REMOVAL OF THE CD MECHANISM

1) Remove the four retaining screws, then remove the CD mecha. unit (fig 2)

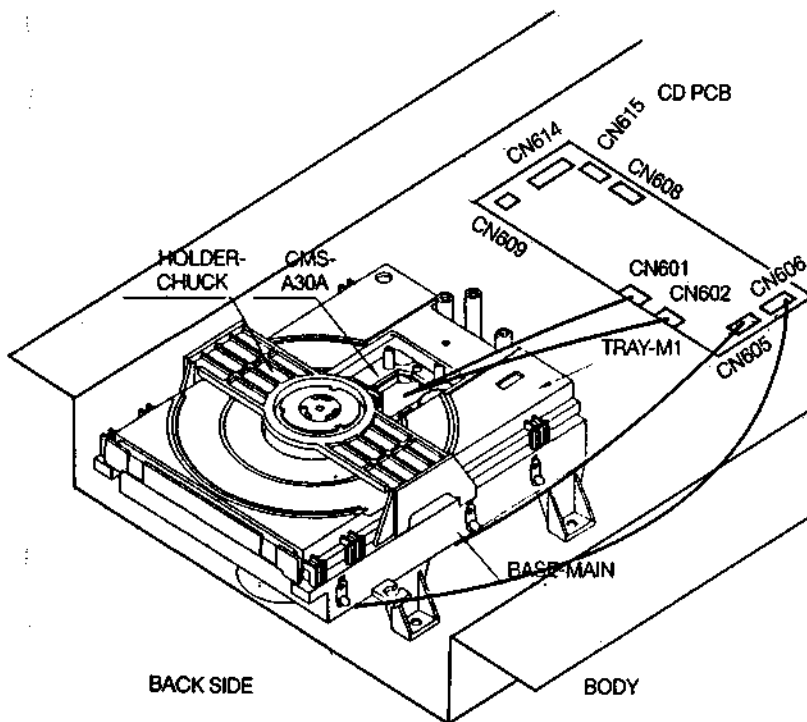

Fig. 1

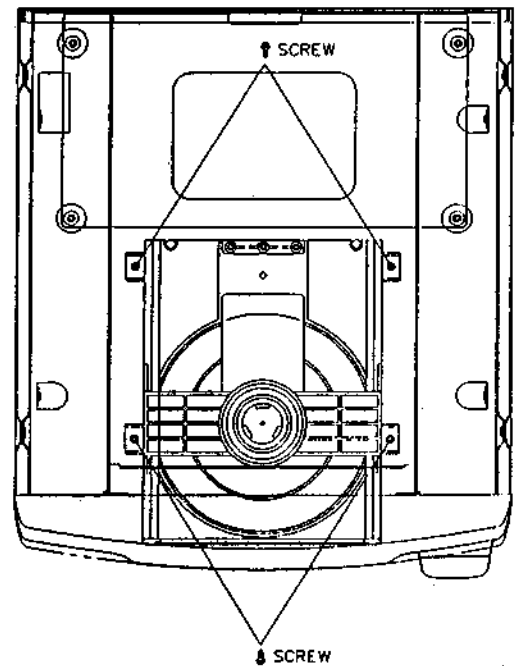

Fig. 2

4.REMOVAL OF THE TRAY BLOCK

- 1)Remove the four retaining screws for clamper and tray.
(fig. 3)

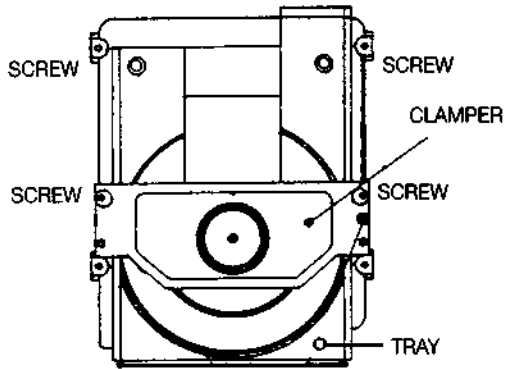

Fig. 3

- 2)Slide the bracket in the direction of the arrow (fig. 4)

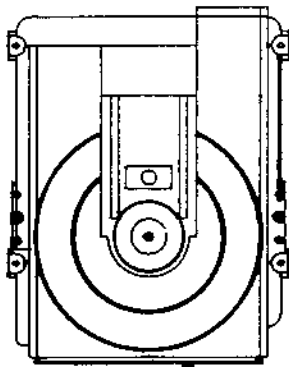

Fig. 4

- 3)Pull out the tray ass'y slowly in the direction of the arrow
(fig. 5)

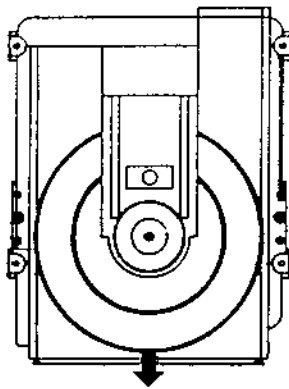

Fig. 5

- 4)Remove the tray block.

5.REPLACEMENT OF THE TRAY MOTOR

- 1)Remove the tray-belt
- 2)Unsolder the lead wires and PCB of the tray-motor with a soldering-iron.
- 3)Remove the tray-motor retaining screws.
- 4)Remove and replace the tray-motor.
- 5)Reassemble in the reverse order.

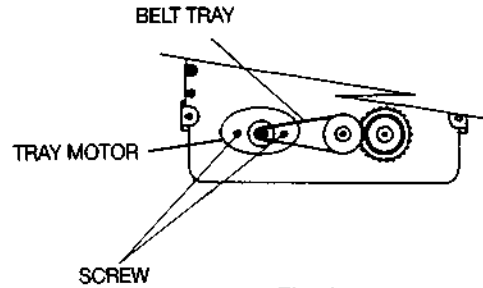

Fig. 6

6.REPLACEMENT OF THE SLED-MOTOR & REPLACEMENT OF THE SPINDLE -MOTOR

- Remove the four SHAFT CD and the four RUBBER CD for ASS'Y-MECHA FEED.
- Replacement of the spindle-motor itself is not recommended, because the adjustment of the turn table height is quite critical and necessitating the use of a special jig.
- Therefore, when need to replace the spindle-motor, please replace with a ASS'Y-MECHA FEED.
(CD MECHA;CMS-A30A:ADCD-00110-031)

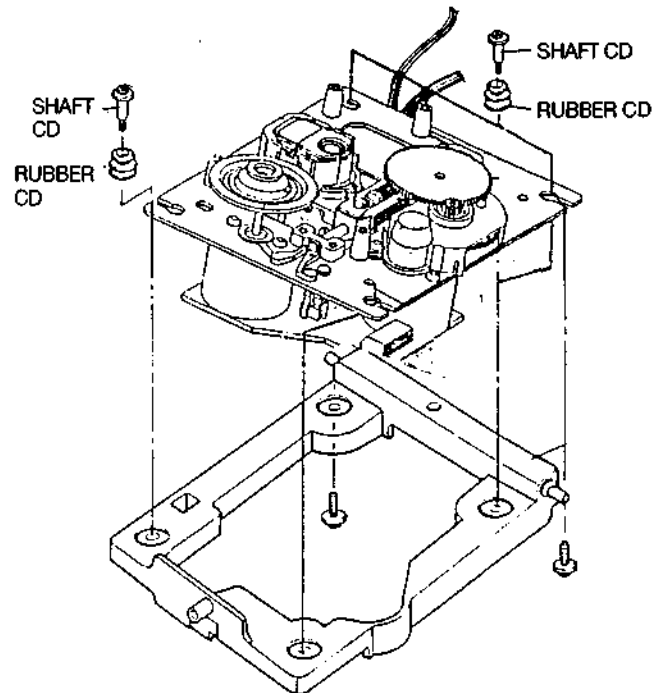

Fig. 7

2. CASSETTE DECK MECHANISM

2-1. REPLACEMENT OF THE PINCH ROLLER BLOCK

- 1) Pull the PINCH ROLLER BLOCK upward(↑) while releasing the PINCH ROLLER RETAINING HOOK.
- 2) Reassemble in the reverse order.

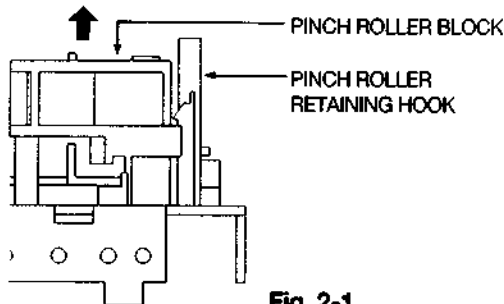

Fig. 2-1

2-2. REPLACEMENT OF THE PB HEAD (TAPE I)

- 1) Remove the two HEAD RETAINING (A) SCREWS.
- 2) Pull out the HEAD and disconnect all the lead wires with a soldering iron, then replace the PB HEAD.
- 3) Reassemble in the reverse order. After replacement, head azimuth and PB level adjustment must be performed.



Fig. 2-2

Fig. 2-3

2-3. REPLACEMENT OF THE REC/PB HEAD (TAPE II)

- 1) Remove the two HEAD RETAINING (A) SCREWS.
- 2) Pull out the HEAD and disconnect all lead wires with a soldering iron, then replace the REC/PB HEAD.
- 3) Reassemble in the reverse order, After replacement, head azimuth, PB level BIAS current and REC level adjustments must be performed.

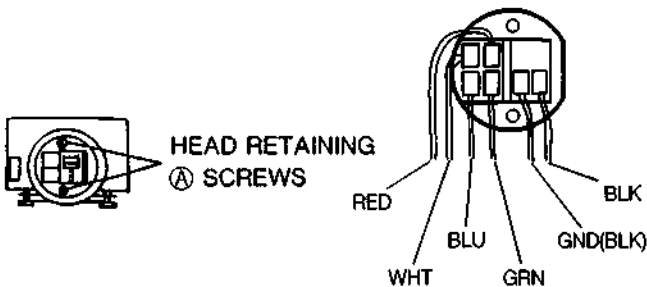

Fig. 2-4

Fig. 2-5

2-4. REPLACEMENT OF THE CAPSTAN MOTOR

- 1) Disconnect the lead wire of the CAPSTAN MOTOR with a soldering iron.
- 2) Remove the CAPSTAN MOTOR RETAINING (B) SCREWS, then replace the CAPSTAN MOTOR.
- 3) Reassemble in the reverse order and set the DRIVE BELT. After replacement, tape speed adjustment must be performed.

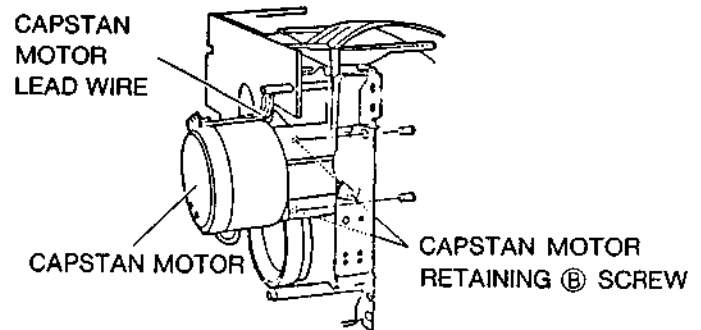

Fig. 2-6

2-5. REPLACEMENT OF THE DRIVE BELT

- 1) Remove the CAPSTAN MOTOR RETAINING (B) SCREWS. (refer illustration Fig. 2-6)
- 2) Separate the MOTOR PCB from the MECHA BLK. Replace the DRIVE BELT.
- 3) Reassemble in the reverse order. After replacement, confirm the tape speed and if the result is not satisfactory, adjust the tape speed.

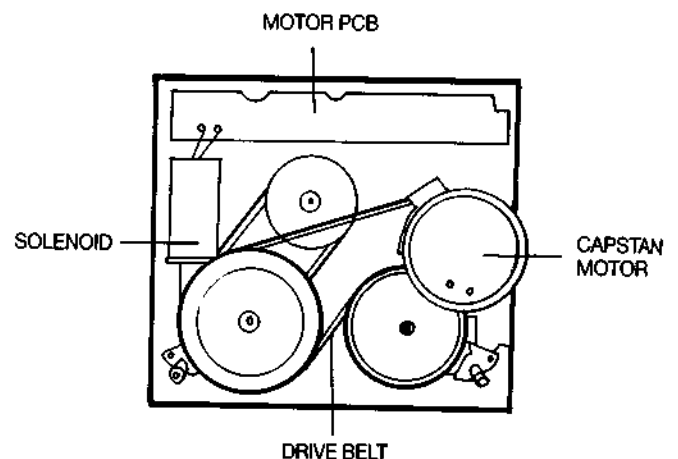

Fig. 2-7

MECHANICAL ADJUSTMENT

2-6. ADJUSTMENT OF THE PB HEAD AZIMUTH ALIGNMENT (TAPE I)

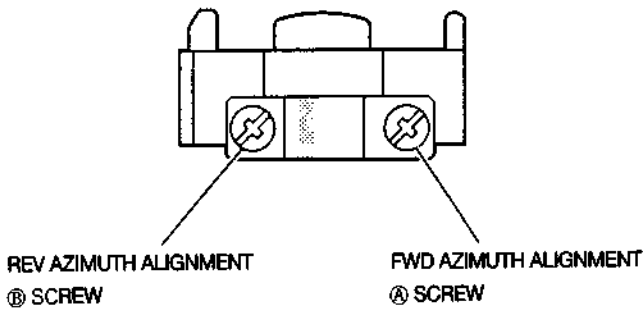

Fig. 2-8

- 1) Connect an AC milli-voltmeter to the TEST POINT TP401 (refer to the illustration on page 8.) and connect an oscilloscope's input CH-1 and CH-2 to the output of the AC milli-voltmeters.
- 2) Play back the 10kHz (-15dB), HEAD AZIMUTH ALIGNMENT TEST TAPE (MTT-357G) then adjust the PB HEAD AZIMUTH ALIGNMENT Ⓐ (FWD PLAY) and Ⓑ (REV PLAY) SCREW respectively so that the reading on the AC milli-voltmeters are at maximum and waveforms on the oscilloscope are in the same phase, in both FWD and REV directions.

2-7. ADJUSTMENT OF THE REC/PB HEAD AZIMUTH ALIGNMENT (TAPE II)

- 1) Connect an AC milli-voltmeter to the TEST POINT TP401 (refer to the illustration on page 8.) and connect an oscilloscope's input CH-1 and CH-2 to the output of the AC milli-voltmeters.
- 2) Play back the 10kHz (-15dB), HEAD AZIMUTH ALIGNMENT TEST TAPE (MTT-357G) then adjust the REC/PB HEAD AZIMUTH ALIGNMENT Ⓐ (FWD PLAY) and Ⓑ (REV PLAY) SCREW respectively so that the reading on the AC milli-voltmeters are at maximum and waveforms on the oscilloscope are in the same phase, in both FWD and REV directions.

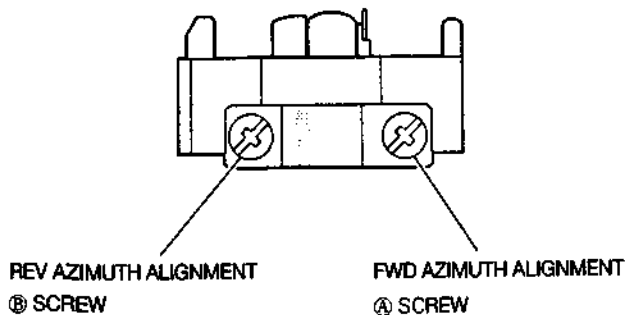

Fig. 2-9

2. TUNER ELECTRICAL ADJUSTMENT

NOTE: 1. Set the S.S.G. to 1kHz, 75kHz deviation for **U**, **S**, **B**, **Y**, **V2** or **E** model, 1kHz, 40kHz deviation for **V1** model.

STEP	ADJUSTMENT ITEM
1.	SSG FREQ. & OUTPUT LEVEL
2.	SET Tuning FREQ.
3.	ADJ. Part
4.	REMARKS(●) & RESULT(*)

Test Point Adjustment Part

FM

3	DISTORTION(STEREO)
1.	98.0MHz, 60dB μ (STEREO L or R channel only)
2.	98.0MHz (PRESET 3CH)
3.	IFT (FRONT END)
4.	● Connect the distortion meter to LINE OUT. * Minimum Distortion

2	TUNING LED
1.	98.0MHz, 22dB μ (MONO)
2.	98.0MHz (PRESET 3CH)
3.	TUNED indicator on the FL display.
4.	* TUNED indicator is lit.

1	CENTER VOLTAGE
1.	98.0MHz, 60dB μ (MONO)
2.	98.0MHz (PRESET 3CH)
3.	T105
4.	● Connect the DC Digital Voltmeter to both ends of R138. * $0 \pm 50mV$

4	STEREO SEPARATION
1.	98.0MHz, 60dB μ (STEREO L or R channel only)
2.	98.0MHz (PRESET 3CH)
3.	SV102
4.	● Connect the milli-voltmeter to LINE OUT. * Minimum output level for opposite channel.

LW <SW>

2	LW <SW> SENSITIVITY
1.	160kHz, 70dB μ <4MHz, 35dB μ >
2.	160kHz <4MHz> PRESET 12CH <12CH>
3.	T102
4.	● Connect the milli-voltmeter to LINE OUT * Maximum output level.

1	LW <SW> OSC
1.	—
2.	144kHz <3.8MHz> PRESET 11CH <11CH>
3.	T104
4.	● Connect the Digital DC Voltmeter between JW4 and GND. * $1.4 \pm 0.1V$ < $1.0 \pm 0.1V$ >

NOTE: 1. Set the S.S.G to 1kHz 30% modulation on each adjustment.
2. Frequencies indicated in < > are for the SW model.

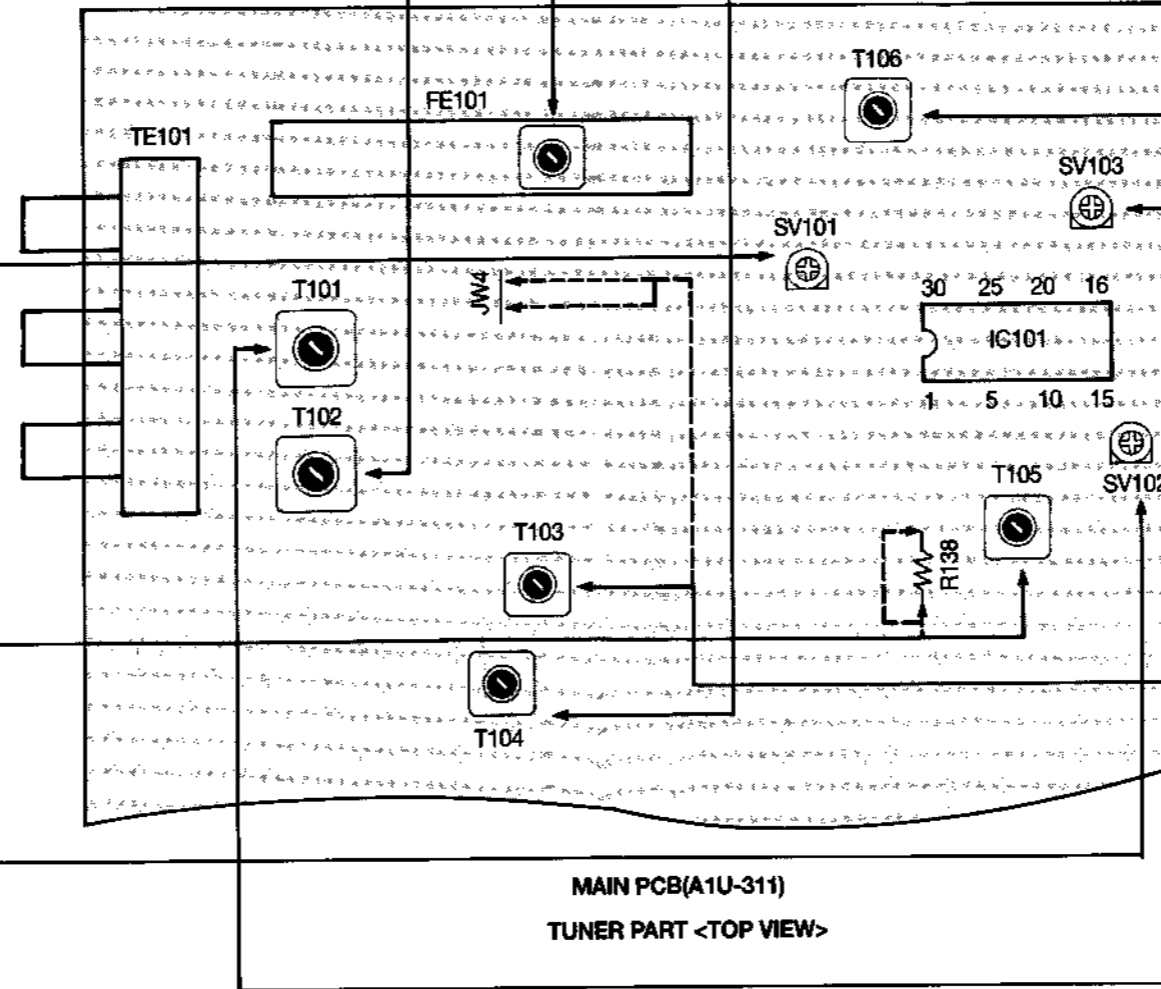

AM

NOTE: Set the S.S.G to 1kHz 30% modulation on each adjustment.

3	AM IF
1.	603kHz, 60dB μ
2.	603kHz (PRESET 7CH)
3.	T106
4.	● Connect the milli-voltmeter to LINE OUT. * Maximum output level.

4	TUNING LED
1.	603kHz, 60dB μ
2.	603kHz (PRESET 7CH)
3.	TUNED indicator on the FL display, SV103
4.	TUNED indicator is lit.

1	AM(MW) OSC
1.	—
2.	531kHz(PRESET 6CH)
3.	T103
4.	● Connect the Digital DC Voltmeter between JW4 and GND. * $1.0V \pm 0.1V$

2	AM(MW) SENSITIVITY
1.	603kHz, 70dB μ
2.	603kHz (PRESET 7CH)
3.	T101
4.	● Connect the milli-voltmeter to LINE OUT * Maximum output level.

IV. ADJUSTMENT

1. TUNER INSTRUMENT CONNECTIONS

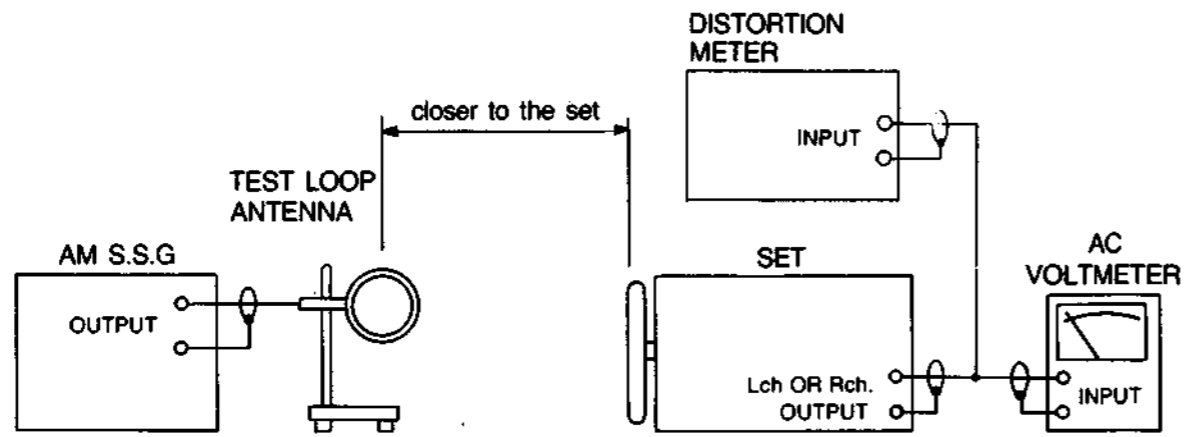

Instrument connection for AM (MW, LW) section adjustment

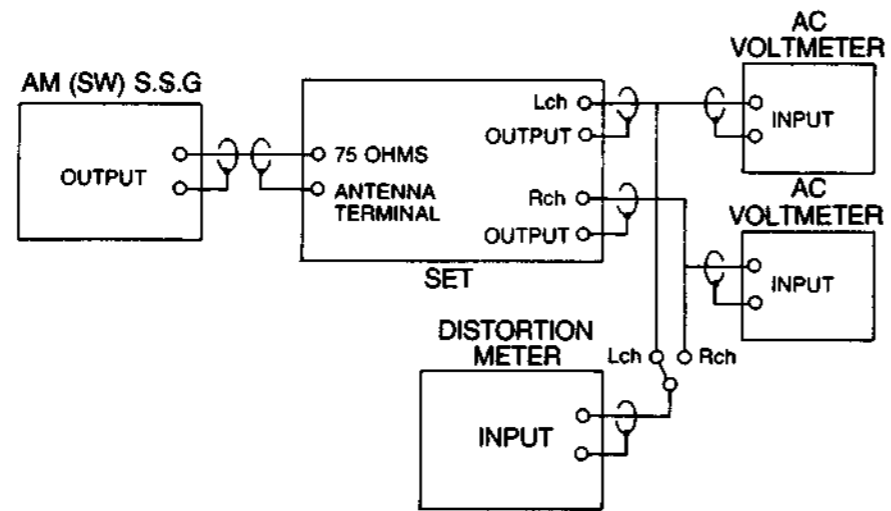

Instrument connection for AM (SW) section adjustment

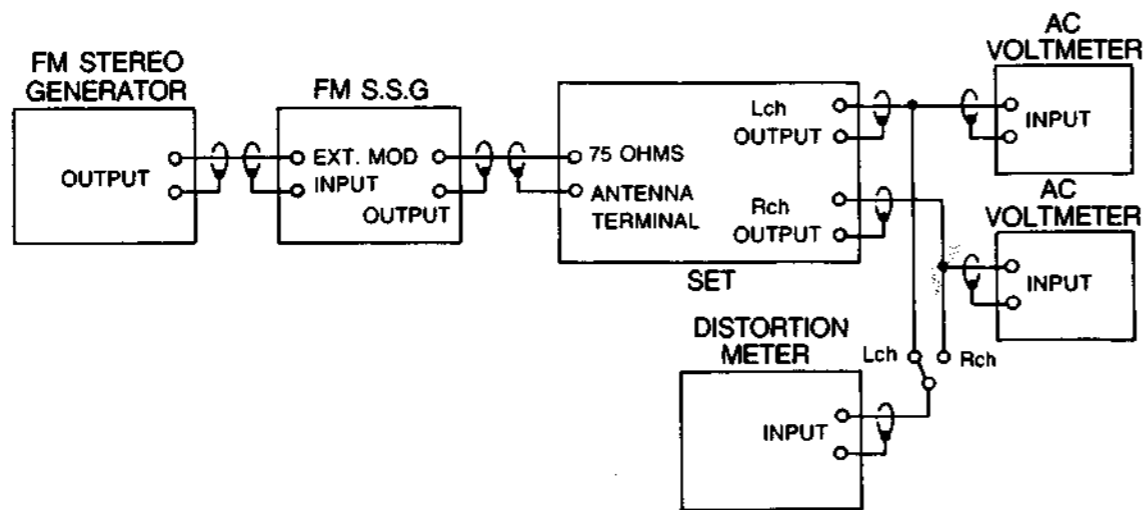

Instrument connection for FM section adjustment

4. CASSETTE DECK ELECTRICAL ADJUSTMENT

[PRECAUTIONS BEFORE ADJUSTMENT]

1. Before adjustment, clean and de-magnetize the heads and tape guides.
2. Set the Dolby NR switch off.
3. Use the following recording test tapes.
NORMAL position : TDK AC-224
CrO₂ position : TDK AC-513
4. LINE OUT = TP401

STEP	ADJUSTMENT
1.	TEST TAPE/INPUT SIGNAL
2.	MODE
3.	CHECK POINT, ADJUSTMENT PART
4.	REMARKS(●) and RESULT(*)

Adjustment Part Test Point

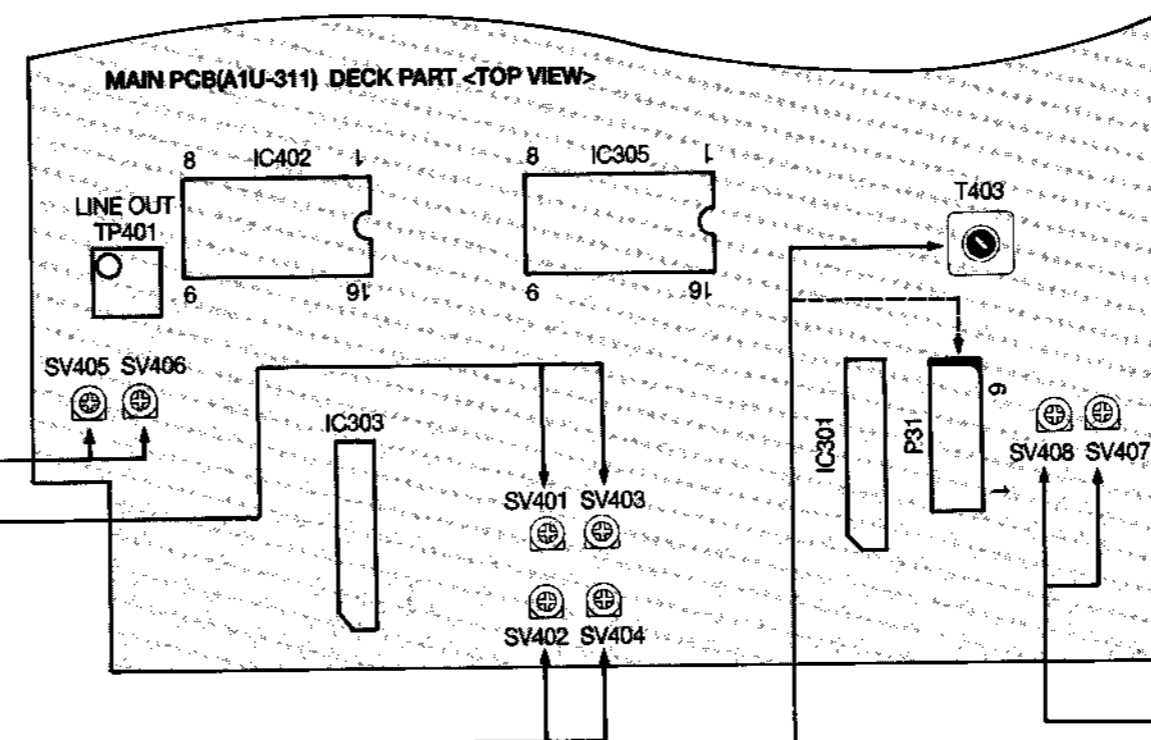
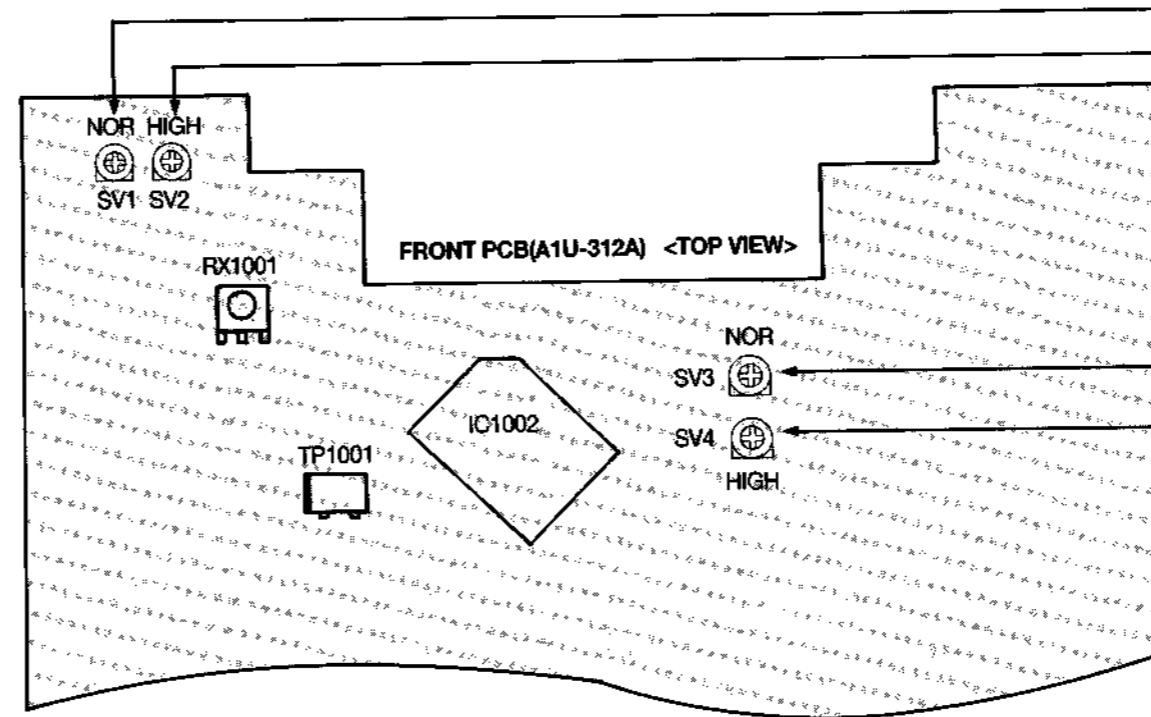

- | 1 | TAPE I HIGH (X2) SPEED |
|----|--|
| 1. | 3,000Hz test tape (MTT-111DN) in TAPE I
A blank tape in TAPE II |
| 2. | PLAY (press the X2 DUBBING START button) |
| 3. | LINE OUT, SV2 |
| 4. | ● Connect a frequency counter to the LINE OUT
* 6,000 ± 120Hz |

- | 2 | TAPE I NORMAL (X1) SPEED |
|----|---|
| 1. | 3,000Hz test tape (MTT-111DN) |
| 2. | PLAY |
| 3. | LINE OUT, SV1 |
| 4. | ● Connect a frequency counter to the LINE OUT
* 3,000 ± 60Hz |

- | 3 | TAPE II HIGH (X2) SPEED |
|----|--|
| 1. | 3,000Hz test tape (MTT-111DN) in TAPE II |
| 2. | PLAY (During adjustment, short TP1001. After adjustment, remove it.) |
| 3. | LINE OUT, SV4 |
| 4. | ● Connect a frequency counter to the LINE OUT
* 6,000 ± 120Hz |

- | 4 | TAPE II NORMAL (X1) SPEED |
|----|---|
| 1. | 3,000Hz test tape (MTT-111DN) |
| 2. | PLAY |
| 3. | LINE OUT, SV3 |
| 4. | ● Connect a frequency counter to the LINE OUT
* 3,000 ± 60Hz |

- | 5 | HEAD AZIMUTH ALIGNMENT (TAPE I & II) |
|----|--|
| 1. | 10KHz -15VU test tape (MTT-357G) |
| 2. | PLAY |
| 3. | LINE OUT, HEAD AZIMUTH ALIGNMENT SCREW (refer to the page 14) |
| 4. | ● Connect an AC milli-voltmeter to LINE OUT
* Maximum output level. |

- | 8 | BIAS OSC FREQUENCY |
|----|---|
| 1. | CrO ₂ type blank tape |
| 2. | REC |
| 3. | P31 (6 pin), T403 |
| 4. | ● Connect a frequency counter between P31 (6 pin) and GND
* 105 ± 5KHz |

- | 9 | RECORDING LEVEL |
|----|--|
| 1. | NORMAL recording test tape (AC-224), 1KHz, -6.0dBs (LINE OUT) |
| 2. | REC → PLAY |
| 3. | LINE OUT, SV405 (L-ch), SV406 (R-ch) |
| 4. | ● Connect an AC milli-voltmeter to LINE OUT
* -6dBs (± 1dB) |
-
- | 7 | TAPE I PB LEVEL |
|----|--|
| 1. | 400Hz test tape (MTT-150) |
| 2. | PLAY |
| 3. | LINE OUT, SV401 (L-ch), SV403 (R-ch) |
| 4. | ● Connect an AC milli-voltmeter to LINE OUT
* 580mV (-2.5dBs) |
-
- | 6 | TAPE II PB LEVEL |
|----|--|
| 1. | 400Hz test tape (MTT-150) |
| 2. | PLAY |
| 3. | LINE OUT, SV402 (L-ch), SV404 (R-ch) |
| 4. | ● Connect an AC milli-voltmeter to LINE OUT
* 580mV (-2.5dBs) |

- | 10 | NORMAL POSITION BIAS |
|----|---|
| 1. | NORMAL recording test tape (AC-224), 1KHz and 10KHz, -26dBs (LINE OUT) |
| 2. | REC → PLAY |
| 3. | LINE OUT, SV408 (L-ch), SV407 (R-ch) |
| 4. | ● Connect an AC milli-voltmeter to LINE OUT
* Playback level difference between 1kHz and 10kHz after recording is within ± 0.3dB |

3. CD ELECTRICAL ADJUSTMENT

* CD adjustment starts after T.O.C. in the normal mode.

STEP	ADJUSTMENT
1.	TEST DISC
2.	MODE
3.	TEST POINT and ADJUSTMENT parts.
4.	REMARK(●) and RESULT(*)

Test Point Adjustment Part

4 TRACKING SERVO GAIN

1. Test disc A-BEX TCD-781
2. PLAY mode
3. IC601 48pin/SV601
4. ● Connect an oscilloscope to the IC601 48pin.
* 180mV

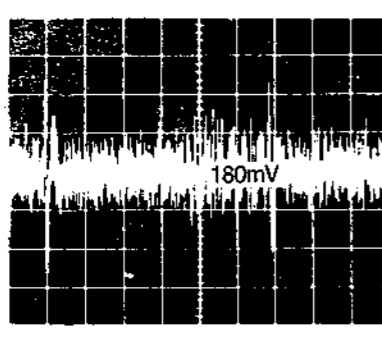

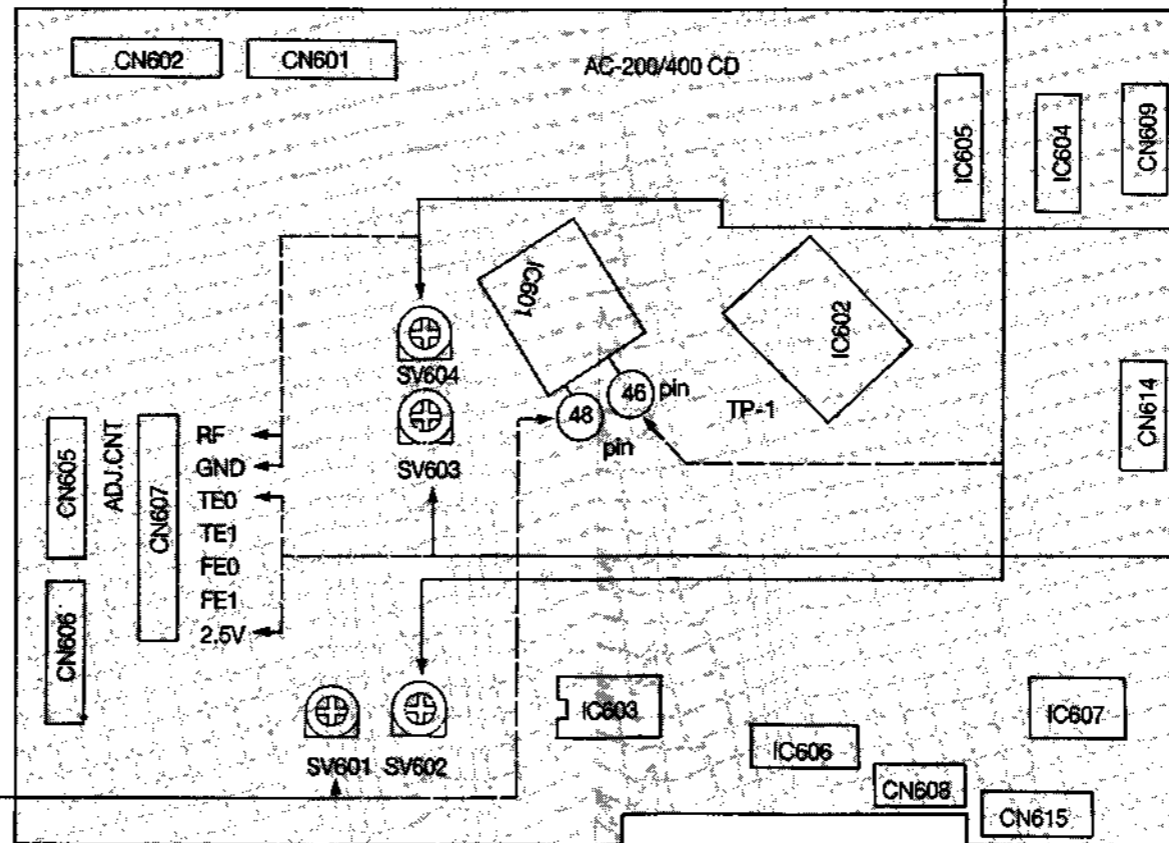

3 FOCUS SERVO GAIN

1. Test disc A-BEX TCD-781
2. PLAY mode
3. IC601 46pin/SV602
4. ● Connect an oscilloscope to the IC601 46pin.
* 50mV

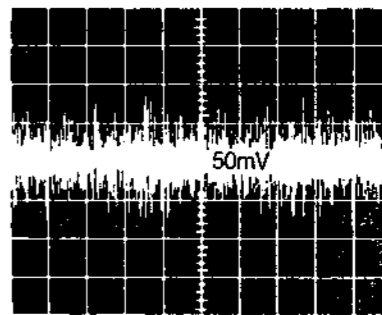

1 FOCUS BIAS

1. Test disc A-BEX TCD-781
2. PLAY mode
3. CN607(1, 2pin)/SV604
4. ● Connect an oscilloscope to the RF and GND
Press PLAY button and adjust the RF signal to maximum
* 1.4V p-p

2 E-F BALANCE

1. Test disc A-BEX TCD-781
2. PLAY mode
3. CN607(3, 7pin)/SV603
4. ● Connect an oscilloscope to the TE0 or TE1 and 2.5V(CN607 7pin)
● Set SV601 to minimum position.
(Center → Left) then, set SV601 to CENTER position
* A=B

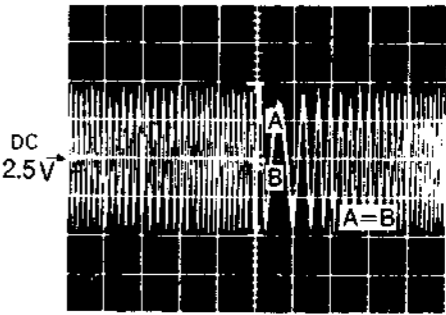

1. RECOMMENDED SPARE PARTS

Ref. No.	Part No.	Description			
1	* ACAC-00063-000	CORD-AC [E, V, U, Y] KKP419C	31	ICDG-01300-TP0	ECHO SOUND PROCESSOR ES56028E DIP28 [405K]
2	* ACAC-00083-000	CORD-AC [S] KKP-500	32	ICDG-00370-S20	IC TAPE SELECTOR APC1330HA SIP9
3	* ACAC-00094-000	CORD-AC [B] CW3201	33	ICDG-00560-S00	IC MOTOR DRIVER BA6208 SIP9
4	BTCE-00050-004	FILTER-CERAMIC SFU 450B	34	ICDG-00940-SE0	IC D.S.P+D.A.C (CDP) KS-9282B QFP80
5	BTCE-00060-107	FILTER-CERAMIC [EXCEPT V] SFE 10.7MS3G-A	35	ICDG-00950-SE0	IC RF+SERVO (CDP) KA-9220B QFP80
6	BTCE-00152-107	FILTER-CERAMIC [V] SFE 10.7MJA 10M-A	36	ICHP-00070-S10	IC HYBRID AMP-POWER STK4142 J 25W x 2 SIP18
7	* CACS-U102K-129	CAPACITOR AC DE7090B102KVA1-KC 400V S	37	ICHY-00210-SG0	IC REMOTE RECEIV NJH41H380-L UNIT4
8	DDMR-00210-T11	DIODE-RECTIFIER 1N5402S (200V 3A) DO-20 M	38	ICLN-00540-S00	IC 2CH PRE AMP BA3416BL DIP16
9	DDSV-0003B-S30	DIODE-VVC 1SV149B AM 8V DIP2 S	39	ICLN-00610-S10	IC AUDIO SENSER LA2000 SIP9
10	DDTR-00040-T10	DIODE-RECTIFIER 1N4004 (400V 1A) DO-41 T	40	ICLN-00681-SA0	IC DOLBY B HA12136A DIP16
11	DDTS-00060-S00	DIODE-SI 1SS131 (90V 0.13A) DO-40 T	41	ICLN-01550-S50	IC 7BAND EQ AN7337N DIP20
12	DDTZ-G056B-S00	DIODE ZENER MTZ5.6B 5.45-5.73 DO40 T	42	ICLN-01810-S40	IC VOCAL FADER [405K] CXA1642P DIP8
13	DDTZ-G082C-S00	DIODE ZENER MTZ8.2C 8.03-8.45 DO40 T	43	ICMP-01260-SA0	IC UCOMPUTER TCM-9503-008 QIP100
14	DDTZ-G091B-S00	DIODE ZENER MTZ9.1B 9.01 DO40 T	44	ICMP-01270-SA0	IC UCOMPUTER TCM-9503-009 QIP80
15	DDTZ-G130B-S00	DIODE ZENER MTZ13B 12.55-13.21 DO40 T	45	ICLN-01590-SE0	IC MOTOR CONTROL CDP KA-9258D HSOP28
16	DPFL-00370-GCF	V.F.D CM1369D	46	ICOP-00130-SE0	IC DUAL OP AMP KA4558S SIP9
17	DPLT-00073-YC3	DOT-LED SLR-34YC3 YEL R3 TAPPING	47	ICLN-01640-S10	IC AM/FM IF MPX LA1851N DIP30
18	DPLT-00311-WW5	DOT-LED SPR-54MW (2COLOR) R5 D	48	ICOP-00131-SE0	IC DUAL OP AMP KA4558C DIP8
19	DPLT-00452-YC5	DOT-LED AL-151YC YEL R5 N	49	ICRG-00081-SE0	IC REGULATOR KA7924 24V 3mm TO-220
20	ESRY-00010-120	RELAY HR-703V DC 12V	50	ICRG-00091-SE0	IC REGULATOR KA7806 6V 3mm TO-220
21	* FGFB-S1002-337	FUSE GLASS [U, Y] 1A 250V 5 x 20	51	ICRG-00191-SE0	IC REGULATOR KA7912 12V 3mm TO-220
22	* FGFB-S2002-337	FUSE GLASS 2A 250V 5 x 20	52	ICRG-00218-SE0	IC REGULATOR KA7812 12V 3mm TO-220
23	* FGFB-S8001-337	FUSE GLASS 800mA 250V 5 x 20	53	ICRG-00240-SE0	IC REGULATOR MC78L05 5V TO-92
24	ICCM-00060-SQ0	IC QUAD SWITCH GD4066B DIP14	54	IFFD-00140-E60	IFT-FM DET AFD014 7.4mm-CAN
25	ICCM-00170-SQ0	IC 4CH MUX/DEMUX GD4052B DIP16	55	KIAA-00140-ED0	COIL-AM IFT AAA-014B
26	ICCM-20360-T90	IC VOLTAGE DETECTOR S80721AN TO-90	56	KIAO-00240-E20	COIL-AM OSC AAO024 MW 7mm-CAN
27	ICCM-20380-S10	IC PLL LC7218 DIP24S	57	KIAO-00250-E20	COIL-AM OSC AAO025 LW 7mm-CAN
28	ICCM-20390-SG0	IC ELECTRONIC VOLUME NJU7305 SDIP28	58	KIAO-00260-E20	COIL-AM OSC AAO026 SW 7mm-CAN
29	ICCM-20501-S30	IC CMOS TC4094B DIP16	59	KIAT-00301-E20	COIL-AM ANT AAT030-1 LW 10mm-CAN
30	ICCM-20710-TQ0	IC GRAPHIC EQ FILTER XR-1093 DIP14	60	KIAT-00351-E20	COIL-AM ANT AAT035-1 MW 10mm-CAN
			61	KIAT-00370-E20	COIL-AM ANT AAT037 SW 10mm-CAN

V. PARTS LIST

ATTENTION

1. When placing an order for parts, be sure to list Part No, Model No, and the description of each part. Otherwise, the non-delivery of the part or the delivery of a wrong part may result.
2. Please make sure that Part No. is correct when ordering.
If not, a part different from the one you ordered may be delivered.
3. Since the parts shown in Parts List of Preliminary Service Manual may have been the subject of changes, please use this Parts List for all future reference.

[NOTE]

1. This Parts List lists those parts which are considered necessary for repairs. Other common parts, such as resistors and capacitors, are listed in the "Common List for Service Parts" from which these parts should be selected and stocked.
2. The Recommended Spare Parts List shows those parts in the Parts List which are considered particularly important for service.
3. Parts not shown in the Parts List and "Common List for Service Parts" will not in principle be supplied.

WARNING

▲(*) INDICATED SAFETY CRITICAL COMPONENTS. FOR CONTINUED SAFETY, REPLACE SAFETY CRITICAL COMPONENTS ONLY WITH MANUFACTURE'S RECOMMENDED PARTS.

AVERTISSEMENT

▲(*) IL INDIQUE LES COMPOSANTS CRITIQUES DE SÉCURITÉ. POUR MAINTENIR LE DEGRÉ DE SÉCURITÉ DE L'APPAREIL, NE REMPLACER QUE DES PIÈCES RECOMMANDÉES PAR LE FABRICANT.

Ref. No.	Part No.	Description			
62	KIML-A0010-E60	COIL-FM MPX FILTER AMA-001A 19KHz 10mm-CAN	92	TRTA-0056T-SOS	TRANSISTOR P-H FREQ DTA114T-S W/RESIST TO92M
63	KIML-A0020-E20	COIL-FM MPX FILTER [Vi] AFL002 114KHz 7mm-CAN	93	TRTA-0008G-SD0	TRANSISTOR P-H FREQ KTA1266-GR TO92
64	KIRK-00150-E60	COIL-REC CHOCK ARK-015A 8.2mH MOLD SHEL	94	TRTA-0042E-SOS	TRANSISTOR P-H FREQ DTA124E-S TO92M
65	KIRO-00140-E60	COIL-REC OSC ARO014 85KHz 10mm-CAN	95	TRTC-01060-SD0	TRANSISTOR N-H FREQ KTC3203 TO92
66	KIRP-00050-E60	COIL-REC TRAP ARF005A 100KHz 7mm-C	96	TRTC-0010Y-SD0	TRANSISTOR N-H FREQ KTC1923-Y TO92
67	KTAL-00041-072	CRYSTAL HC-49/U 7.200000MHz	97	TRTC-0016G-SD0	TRANSISTOR N-H FREQ KTC3198-GR TO92
68	KTAL-00101-003	CRYSTAL KDSIF 32.768KHz-20P	98	TRTC-0016Y-SD0	TRANSISTOR N-H FREQ KTC3198-Y TO92
69	KTRE-00220-080	RESONATOR CST8.00MTW-TF01	99	TRTC-0039Y-SD0	TRANSISTOR N-H FREQ KTC3205-Y TO92L
70	*PTAJ-02370-C4U	TRANSFORMER-POWER [A] A74-237C-U 74 x 60 120V	100	TRTC-0061E-SOS	TRANSISTOR N-H FREQ DTC124E-S TO92M
71	*PTAJ-02370-H4O	TRANSFORMER-POWER [U, Y] A74-237H-O 74 x 60 110/127/220-230/240V	101	TRTC-0094Y-SD0	TRANSISTOR N-H FREQ KTC3199-Y TO92M
72	*PTAJ-02370-Y4V	TRANSFORMER-POWER [E, B, V] A74-237Y-V 74 x 60 230V	102	TRTC-0034Y-SOS	TRANSISTOR N-H FREQ DTC114Y-S TO92
73	*PTAJ-02370-Z4A	TRANSFORMER-POWER [S] A74-237Z-A 74 x 60 240V	103	TRTC-0039Y-SD0	TRANSISTOR N-H FREQ KTC3205-Y TO92L
74	RFUE-F470J-010	RESISTOR-FUSIBLE 47ohm 1/4W ERQ14AJ470E T	104	TRTD-00200-SD0	TRANSISTOR N-L FREQ KTD-1302 TO92
75	RFUE-F560J-010	RESISTOR-FUSIBLE 56ohm 1/4W ERQ14AJ560E T	105	TUFF-00120-00D	FRONT-END [Vi] FE415-G11
76	RFUM-G1R0J-130	RESISTOR-FUSIBLE 1ohm 1/2W 5% M	106	TUFF-00100-000	FRONT-END [EXCEPT Vi] KHF201V 8V
77	RFUM-G4R7J-130	RESISTOR-FUSIBLE 4.7ohm 1/2W 5% M	107	VFEB-A001B-103	RESISTOR-SEMI FIXED EVN DXA A03 B14 10Kohm
78	RJWT-00000-AA0	RESISTOR-JUMPER WIRE 60mm-TX123 F	108	VFEB-A001B-104	RESISTOR-SEMI FIXED EVN DXA A03 B15 100Kohm
79	RMOE-H4R7J-020	RESISTOR-METAL OXIDE 1W ERG(x) 1SJR7E 4.7ohm T	109	VFEB-A001B-223	RESISTOR-SEMI FIXED EVN DXA A03 BE4 22Kohm
80	SKPH-00350-360	SOCKET-PHONE LGY6501-06	110	VFEB-A001B-472	RESISTOR-SEMI FIXED EVN DXA A03 BQ3 4.7Kohm
81	SKPH-00360-360	SOCKET-PHONE HTJ035-10A	111	VFEB-A001B-102	RESISTOR-SEMI FIXED EVN DXA A03 B13 1Kohm
82	SKRC-00290-020	SOCKET-RCA JK0200440N 2P	112	VFEB-A001B-223	RESISTOR-SEMI FIXED EVN DXA A03 BE4 22Kohm
83	SWPU-00301-038	SWITCH-PUSH 00220014 1K(2C2P)	113	VRAE-D018C-203	VR-ROTARY RK12K1130 0A2 23C-20KC
84	SWSL-00128-012	SWITCH-SLIDE 00120050 30V 0.3A	114	VRBD-E038B-104	VR-ROTARY RK16812MG28A(14B)-100KB x 2
85	SWTA-00220-060	SWITCH-TACT SKHV10910(A) 12V 50mA			
86	SWTA-00230-06V	SWITCH-TACT SKHH17910A 12V 50mA W/GND			
87	SWVS-00103-S50	SWITCH-VOLTAGE SEL [U, Y] JUH1420-0104 250V/5A 1C4P			
88	TEAT-00051-03R	TERMINAL ANTENNA AK1/2-1058A			
89	TRSK-0001G-S30	FET N-CHANNEL 2SK246-GR TO92			
90	TRSA-0023Y-SD0	TRANSISTOR P-H FREQ KTA1658-Y TO220 IS			
91	TRTA-0012Y-SD0	TRANSISTOR P-H FREQ KTA1273-Y TO92L			

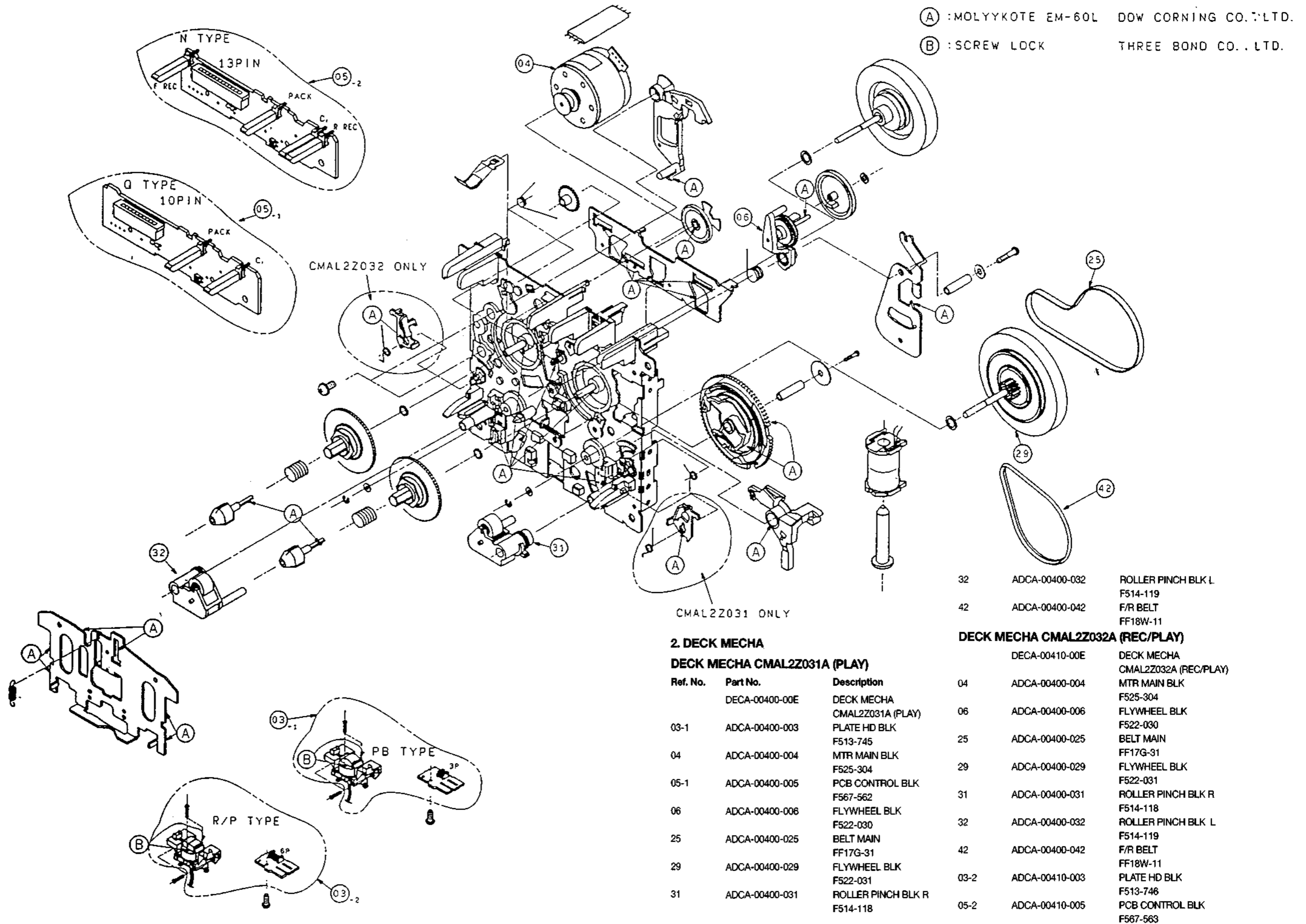

2. DECK MECHA
DECK MECHA CMAL2Z031A (PLAY)

Ref. No.	Part No.	Description
	DECA-00400-00E	DECK MECHA CMAL2Z031A (PLAY)
03-1	ADCA-00400-003	PLATE HD BLK F513-745
04	ADCA-00400-004	MTR MAIN BLK F525-304
05-1	ADCA-00400-005	PCB CONTROL BLK F567-562
06	ADCA-00400-006	FLYWHEEL BLK F522-030
25	ADCA-00400-025	BELT MAIN FF17G-31
29	ADCA-00400-029	FLYWHEEL BLK F522-031
31	ADCA-00400-031	ROLLER PINCH BLK R F514-118

DECK MECHA CMAL2Z032A (REC/PLAY)

Ref. No.	Part No.	Description
	DECA-00410-00E	DECK MECHA CMAL2Z032A (REC/PLAY)
04	ADCA-00400-004	MTR MAIN BLK F525-304
06	ADCA-00400-006	FLYWHEEL BLK F522-030
25	ADCA-00400-025	BELT MAIN FF17G-31
29	ADCA-00400-029	FLYWHEEL BLK F522-031
31	ADCA-00400-031	ROLLER PINCH BLK R F514-118
32	ADCA-00400-032	ROLLER PINCH BLK L F514-119
42	ADCA-00400-042	F/R BELT FF18W-11
03-2	ADCA-00410-003	PLATE HD BLK F513-746
05-2	ADCA-00410-005	PCB CONTROL BLK F567-563

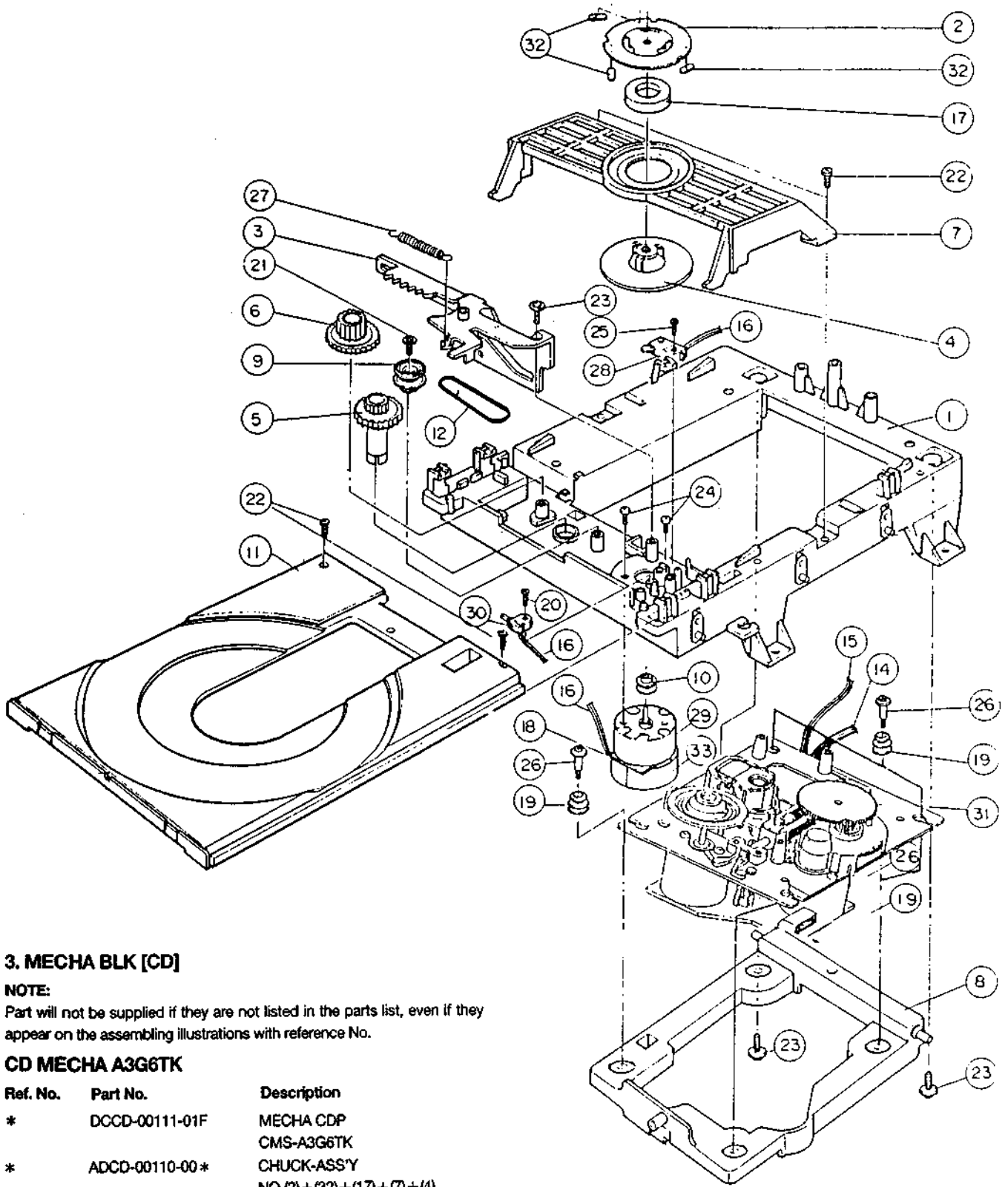

3. MECHA BLK [CD]

NOTE:

Part will not be supplied if they are not listed in the parts list, even if they appear on the assembling illustrations with reference No.

CD MECHA A3G6TK

Ref. No.	Part No.	Description
*	DCCD-00111-01F	MECHA CDP CMS-A3G6TK
*	ADCD-00110-00*	CHUCK-ASS'Y NO (2)+(32)+(17)+(7)+(4)
1	ADCD-00110-001	BASE-MAIN ; ABS BLACK
5	ADCD-00110-005	GEAR(A) ; WHT
6	ADCD-00110-006	GEAR(B) ; POM BLK
11	ADCD-00110-011	TRAY ; ABS BLK
12	ADCD-00110-012	BELT
19	ADCD-00110-019	RUBBER-CD SI WHT45
23	ADCD-00110-023	SCREW ; TAP 3 x 8(WASHER) 17154-100-640
26	ADCD-00110-026	SHAFT-CD ; FE FZY
27	ADCD-00110-027	SPRING-CAM STSWP10.2
28	ADCD-00110-028	SWITCH-LEAF ; MLS-1
29	ADCD-00110-029	MOTOR ; RF-500TB-12560
30	ADCD-00110-030	SWITCH-MICRO LSPPB11
31	ADCD-00111-031	DECK-CD ; CMS-A30A

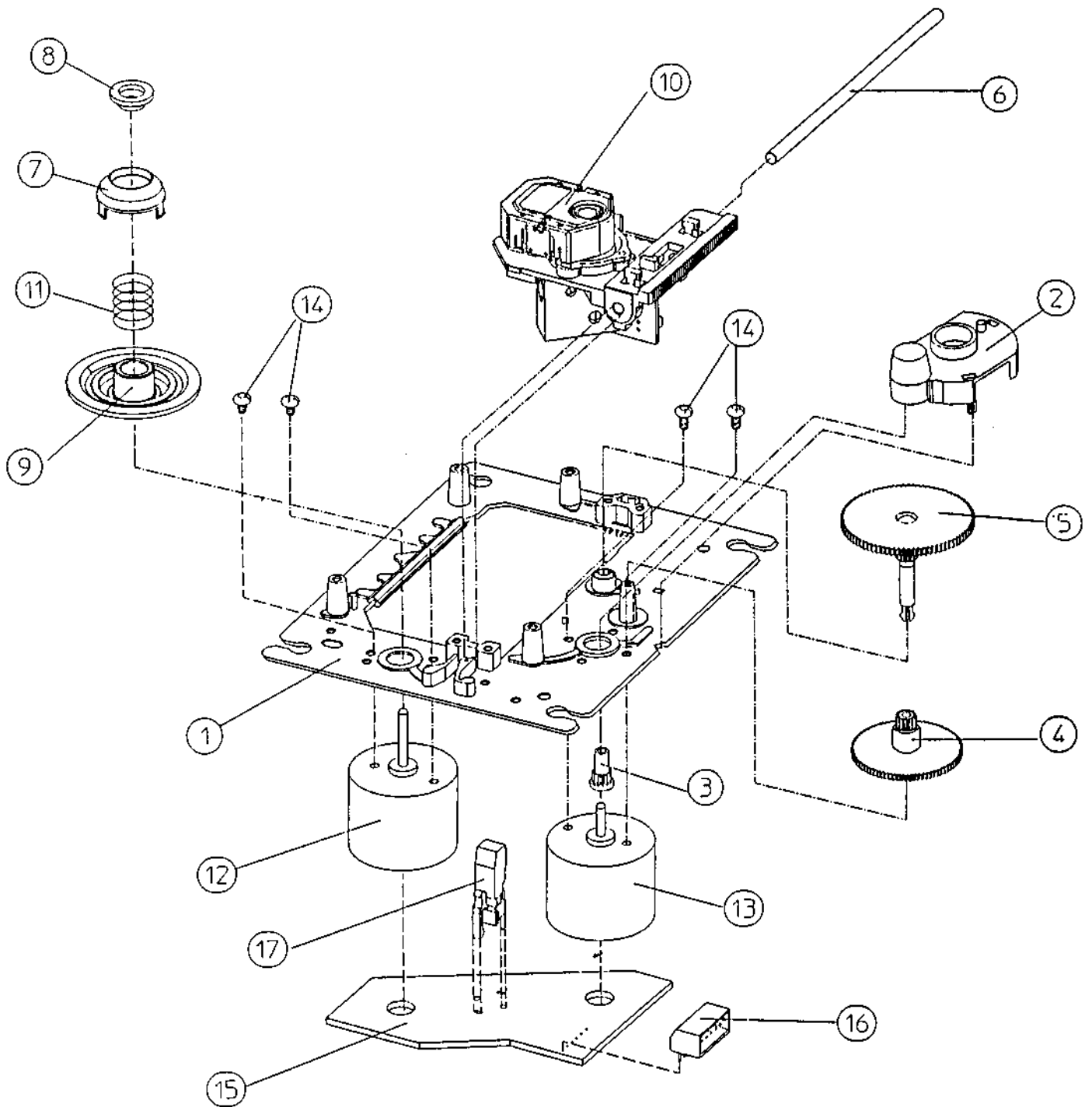

CD MECHA CMS-A30A

Ref. No.	Part No.	Description	Ref. No.	Part No.	Description
1	ADCD-00110-101	CHASSIS-DECK(M)	8	ADCD-00110-108	CENTER KNOB
2	ADCD-00110-102	COVER-GEAR	9	ADCD-00110-109	T/TABLE
3	ADCD-00110-103	GEAR(A)	10	ADCD-00111-110	LASER PICK-UP
4	ADCD-00110-104	GEAR(B)	11	ADCD-00110-111	SPRING-T/TABLE
5	ADCD-00110-105	GEAR(C)	12	ADCD-00110-112	MOTOR-SPINDLE
6	ADCD-00110-106	SHAFT-P/U	13	ADCD-00110-113	MOTOR-FEED
7	ADCD-00110-107	CENTER RING	14	ADCD-00110-114	SCREW-PH
			17	ADCD-00110-117	SWITCH-LEAF

4. AMP PCB (A1U-310(A))

Ref. No.	Part No.	Description
L900	BTAL-00010-025	FILTER-AC LINE FKOB160MH02 2A
C900	* CACS-U102K-129	CAPACITOR AC DE7090B102KVA1-KC 400V S
D905	DDMR-00210-T11	DIODE-RECTIFIER 1N5402S (200V 3A) DO-20 M
D906		
D907		
D908		
D901	DDTR-00040-T10	DIODE-RECTIFIER 1N4004 (400V 1A) DO-41 T
D903		
D904		
D916		
D917		
D918		
D919		
D920		
D921		
D922		
D924		
D925		
D926		
D927		
D928		
D929		
D930		
D902	DDTS-00060-S00	DIODE-SI 1SS131 (90V 0.13A) DO-40 T
D910		
D911		
D912		
D913		
D914		
D915		
ZD901	DDTZ-G056B-S00	DIODE ZENER MTZ5.6B 5.45-5.73 DO40 T
ZD902	DDTZ-G091B-S00	DIODE ZENER MTZ9.1B 9.01 DO40 T
ZD903	DDTZ-G130B-S00	DIODE ZENER MTZ13B 12.55-13.21 DO40 T
RL901	ESRY-00010-120	RELAY HR-703V DC 12V
F901	* FGFB-S2002-337	FUSE GLASS [U, Y] 2A 250V 5 x 20 T
F903		
F904		
F901	FGFB-S8001-337	FUSE GLASS [EXCEPT U, Y] 800mA 250V 5 x 20 T
IC901	ICHP-00070-S10	IC HYBRID AMP-POWER STK4142 I 25W x 2 SIP18
IC906	ICRG-00081-SE0	IC REGULATOR KA7924 24V 3mm TO-220
IC905	ICRG-00091-SE0	IC REGULATOR KA7806 6V 3mm TO-220
IC903	ICRG-00191-SE0	IC REGULATOR KA7912 12V 3mm TO-220
IC902	ICRG-00218-SE0	IC REGULATOR KA7812 12V 3mm TO-220
IC904		
IC908		
IC907	ICRG-00240-SE0	IC REGULATOR MC78L05 5V TO-92
L901	KIBK-00050-E40	COIL-AUDIO CHOCK ABK005 2.2μH
L902		

R919	RCMS-JR22K-410	RESISTOR-CEMENT 0.22ohm 2W 10% S
R929		
FR902	RFUE-F470J-010	RESISTOR-FUSIBLE 47ohm 1/4W ERQ14AJ470E T
FR901	RFUE-F560J-010	RESISTOR-FUSIBLE 56ohm 1/4W ERQ14AJ560E T
FR905	RFUM-G1R0J-130	RESISTOR-FUSIBLE 1ohm 1/2W 5% M
FR906		
FR903	RFUM-G4R7J-130	RESISTOR-FUSIBLE 4.7ohm 1/2W 5% M
R920	RMOE-H4R7J-020	RESISTOR-METAL OXIDE 1W ERG(X) 1SJ4R7E 4.7ohm T
R923		
R925		
R926		
SP101	TESP-00010-08P	TERMINAL SPEAKER AUB-2021
Q912	TRSA-0023Y-SD0	TRANSISTOR P-H FREQ KTA1658-Y TO220IS
Q905	TRTA-0008G-SD0	TRANSISTOR P-H FREQ KTA1266-GR TO92
Q906		
Q914	TRTA-0012Y-SD0	TRANSISTOR P-H FREQ KTA1273-Y TO92L
Q915		
Q920		
Q902	TRTA-0042E-SOS	TRANSISTOR P-H FREQ DTA124E-S TO92M
Q918		
Q911	TRTA-0056T-SOS	TRANSISTOR P-H FREQ DTA114T-S W/RESIST TO92M
Q923	TRTC-0016Y-SD0	TRANSISTOR N-H FREQ KTC3198-Y TO92
Q910	TRTC-0034Y-SOS	TRANSISTOR N-H FREQ DTC114Y-S TO92
Q504	TRTC-0039Y-SD0	TRANSISTOR N-H FREQ KTC3205-Y TO92L
Q901	TRTC-0061E-SOS	TRANSISTOR N-H FREQ DTC124E-S TO92M
Q916		
Q917		
Q919		
Q922		
Q903	TRTD-00200-SD0	TRANSISTOR N-L FREQ KTD-1302 TO92
Q904		
Q908		

5. ECHO PCB (A1U-310(B)) [AC-405K only]

Ref. No.	Part No.	Description
IC505	ICCM-00060-S00	IC QUAD SWITCH GD4066B DIP14
IC506		
IC504	ICDG-01300-TP0	ECHO SOUND PROCESSOR ES58028E DIP28
IC507	ICLN-01810-S40	IC VOCAL FADER CXA1642P DIP8
IC501	ICOP-00130-SE0	IC DUAL OP AMP KA4558S SIP9
IC503		
Q503	TRTA-0042E-SOS	TRANSISTOR P-H FREQ DTA124E-S TO92M
Q520		
Q504	TRTC-0039Y-SD0	TRANSISTOR N-H FREQ KTC3205-Y TO92L
Q501	TRTC-0061E-SOS	TRANSISTOR N-H FREQ DTC124E-S TO92M
Q502		

6. VOLTAGE SELECTOR PCB [U, Y] (A1U-310(C))

Ref. No.	Part No.	Description
SW901	SWVS-00103-S50	SWITCH-VOLTAGE SEL JUH1420-0104 250V/5A 1C4P

7. MAIN PCB (A1U-311(A)) [TUNER/DECK/EQ]

Ref. No.	Part No.	Description	Ref. No.	Part No.	Description
BF101	BTBP-00011-BPM	FILTER-MICA PRINT BPMB6A 88-108MHz [V]	IC303	ICOP-00130-SE0	IC DUAL OP AMP KA4558S SIP9
CF103	BTCE-00050-004	FILTER-CERAMIC SFU 450B	IC803		
CF101	BTCE-00060-107	FILTER-CERAMIC [EXCEPT V _i]	IC807		
CF102	BTCE-00152-107	SFE 10.7MS3G-A FILTER-CERAMIC [V _i]	IC502		[EXCEPT 405K]
CF104	BTCE-00311-004	SFE 10.7MJA 10M-A FILTER-CERAMIC	IC702	ICOP-00131-SE0	IC DUAL OP AMP KA4558C DIP8
D106	DDSV-0003B-S30	DIODE-VVC 1SV149B AM 8V DIP2 S	T105	IFFD-00140-E60	IFT-FM DET AFD014 7.4mm-CAN
D107		[S]	T106	KIAA-00140-ED0	COIL-AM IFT AAA-014B
D110		[S]	T103	KIAO-00240-E20	COIL-AM OSC AAO024 MW 7mm-CAN
D111		[S]	T104	KIAO-00250-E20	COIL-AM OSC [E, B, V] AAO025 LW 7mm-CAN
D101	DDTS-00060-S00	DIODE-SI 1SS131 (90V 0.13A) DO-40 T		KIAO-00260-E20	COIL-AM OSC [U, Y] AAO-026 SW
D102			T102	KIAT-00301-E20	COIL-AM ANT [E, B, V] AAT030-1 LW 10mm-CAN
D103				KIAT-00370-E20	COIL-AM ANT [U, Y] AAT-037 SW
D104			T101	KIAT-00351-E20	COIL-AM ANT AAT035-1 MW 10mm-CAN
D112			T108	KIML-A0010-E60	COIL-FM MPX FILTER AMA-001A 19KHz 10mm-CAN
D114			T109		
D115			T107	KIML-A0020-E20	COIL-FM MPX FILTER [V _i] AFL002 114KHz 7mm-CAN
D301			T408	KJRK-00150-E60	COIL-REC CHOCK ARK-015A 8.2mH MOLD SHIELD
D401			T409		
D402			T403	KIRO-00140-E60	COIL-REC OSC ARO014 85KHz 10mm-CAN
D403			T103	KIRP-00050-E60	COIL-REC TRAP ARP005A 100KHz 7mm-C
D404			T104		
D405			T105		
D406			T106		
D105	DDTS-00100-S00	DIODE-SI [U, Y] 1SS135 (35V 0.1A) DO-40 T	T401		
D113			T402		
ZD101	DDTZ-G056B-S00	DIODE ZENER MTZ5.6B 5.45-5.73 DO40 T	T404		
ZD702	DDTZ-G082C-S00	DIODE ZENER MTZ8.2C 8.03-8.45 DO40 T	T405		
ZD801			T406		
ZD802			T407		
ZD102	DDTZ-G091B-S00	DIODE ZENER MTZ9.1B 9.01 DO40 T	X101	KTAL-00041-072	CRYSTAL HC-49/U 7.200000MHz
IC801	ICCM-00170-S00	IC 4CH MUX/DEMUX GD4052B DIP16	JK801	SKRC-00290-020	SOCKET-RCA JK0200440N 2P
IC102	ICCM-20380-S10	IC PLL LC7218 DIP24S	SW401	SWSL-00128-012	SWITCH-SLIDE 00120050 30V 0.3A
IC806	ICCM-20390-SG0	IC ELECTRONIC VOLUME NJU7305 SDIP28	SW402	SWTA-00230-06V	SWITCH-TACT SKHH17910A 12V 50mA W/GND
IC304	ICCM-20501-S30	IC CMOS TC4094B DIP16	TE101	TEAT-00051-03R	TERMINAL ANTENNA AK1/2-1058A
IC305			Q110	TRSK-0001G-S30	FET N-CHANNEL 2SK246-GR TO92
IC301	ICDG-00370-S20	IC TAPE SELECTOR μPC1330HA SIP9	Q106	TRTA-0008G-SD0	TRANSISTOR P-H FREQ KTA1266-GR TO92
IC701	ICDG-00560-S00	IC MOTOR DRIVER BA6208 SIP9	Q107		
IC401	ICLN-00540-S00	IC 2CH PRE AMP BA3416BL DIP16	Q108		
IC302	ICLN-00610-S10	IC AUDIO SENSER LA2000 SIP9	Q703	TRTA-0042E-SOS	TRANSISTOR P-H FREQ DTA124E-S TO92M
IC402	ICLN-00681-SA0	IC DOLBY B HA12136A DIP16	Q101	TRTC-0010Y-SD0	TRANSISTOR N-H FREQ KTC1923-Y TO92
IC804	ICLN-01550-S50	IC 7BAND EQ AN7337N DIP20	Q116		
IC805			Q109	TRTC-0016G-SD0	TRANSISTOR N-H FREQ KTC3198-GR TO92
IC101	ICLN-01640-S10	IC AM/FM IF MPX LA1851N DIP30	Q309	TRTC-0016Y-SD0	TRANSISTOR N-H FREQ KTC3198-Y TO92
			Q702		

Ref. No.	Part No.	Description
Q704		
Q801		
Q802		
Q115	TRTC-0039Y-SD0	TRANSISTOR N-H FREQ
Q304		KTC3205-Y TO92L
Q112	TRTC-0061E-SOS	TRANSISTOR N-H FREQ
Q301		DTC124E-S TO92M
Q302		
Q305		
Q306		
Q307		
Q312		
Q313		
Q314		
Q315		
Q316		
Q317		
Q318		
Q405		
Q406		
Q407		
Q408		
Q413		
Q414		
Q415		
Q416		
Q441		
Q701		
Q102	TRTC-0094Y-SD0	TRANSISTOR N-H FREQ
Q103		KTC3199-Y TO92M
Q401		
Q402		
Q403		
Q404		
Q409		
Q410		
Q419		
Q420		
Q421		
Q422		
Q423		
Q424		
Q425		
Q303	TRTC-01060-SD0	TRANSISTOR N-H FREQ
		KTC3203 TO92
Q104	TRTD-00200-SD0	TRANSISTOR N-L FREQ
Q105		KTD-1302 TO92
Q111		
Q113		
Q114		
Q310		
Q311		
Q417		
Q418		
FE101	TUFF-00100-000	FRONT-END [EXCEPT V _i]
		KHF201V 8V
FE102	TUFF-00120-000	FRONT-END [V _i]
		FE415-G11
SV102	VFEB-A001B-103	RESISTOR-SEMI FIXED
SV401		EVN DXA A03 B14 10Kohm
SV402		
SV403		

SV404		
SV407	VFEB-A001B-104	RESISTOR-SEMI FIXED
SV408		EVN DXA A03 B15 100Kohm
SV101	VFEB-A001B-223	RESISTOR-SEMI FIXED
SV405		EVN DXA A03 BE4 22Kohm
SV406		
SV103	VFEB-A001B-472	RESISTOR-SEMI FIXED
		EVN DXA A03 BQ3 4.7Kohm

8. MOTOR VOLUME P.C BOARD (A1U-311(B))

Ref. No.	Part No.	Description
IC703	ICCM-00060-SQ0	IC QUAD SWITCH
		GD4066B DIP14
IC701	ICDG-00560-SO0	IC MOTOR DRIVER
		BA6208 SIP9
IC702	ICOP-00131-SE0	IC DUAL OP AMP
		KA4558C DIP8
Q703	TRTA-0042E-SOS	TRANSISTOR P-H FREQ
		DTA124E-S TO92M
Q702	TRTC-0016Y-SD0	TRANSISTOR N-H FREQ
Q704		KTC3198-Y TO92
VR701	VRBD-E038B-104	VR-ROTARY
		RK16812MG28A (14B)-100KB × 2

9. FRONT P.C BOARD (A1U-312(A))

Ref. No.	Part No.	Description
D1001	DDTR-00040-T10	DIODE-RECTIFIER
D1002		1N4004 (400V 1A) DO-41 T
D1003		
D1004		
D1007		
D1008		
D1006	DDTS-00060-SO0	DIODE-SI
D1009		1SS131 (90V 0.13A) DO-40 T
D1010		
D1011		
D1012		
Z1001	DDTZ-G051B-SO0	DIODE ZENER
Z1002		MTZ5.1B 4.94-5.2 DO40 T
VFD1	DPFL-00370-GCF	V.F.D
		CM1369D
IC1004	ICCM-20360-T90	IC VOLTAGE DETECTOR
		S80721AN TO-90
IC1003	ICCM-20710-TQ0	IC GRAPHIC EQ FILTER
		XR-1093 DIP14
RX1001	ICHY-00210-SG0	IC REMOTE RECEIV
		NJH41H380-L UNIT4
IC1001	ICMP-01260-SA0	IC μ-COMPUTER
		TCM-9503-008 QIP100
IC1002	ICMP-01270-SA0	IC μ-COMPUTER
		TCM-9503-009 QIP80
X1002	KTAL-00101-003	CRYSTAL
		KDSIF 32.768KHz-20P
X1001	KTRE-00220-080	RESONATOR
X1003		CST8.00MTW-TF01
SW1001	SWPU-00301-038	SWITCH-PUSH
		00220014 1K(2C2P)
S1002	SWTA-00220-060	SWITCH-TACT
S1003		SKHV10910(A) 12V 50mA
S1004		
S1005		
S1006		

Ref. No.	Part No.	Description
S1007		
S1008		
Q1004	TRTA-0008Y-SD0	TRANSISTOR P-H FREQ KTA1266-Y TO92
Q1016		
Q1005	TRTA-0012Y-SD0	TRANSISTOR P-H FREQ KTA1273-Y TO92L
Q1007		
Q1009		
Q1010		
Q1015		
Q1036	TRTC-0016Y-SD0	TRANSISTOR N-H FREQ KTC3198-Y TO92
Q1003	TRTC-0061E-SOS	TRANSISTOR N-H FREQ DTC124E-S TO92M
Q1006		
Q1008		
Q1011		
Q1012		
Q1013		
Q1017		
Q1019		
Q1020		
Q1021		
Q1022		
Q1023		
Q1024		
Q1025		
Q1026		
Q1027		
Q1035		
Q1037		
SV1	VFEB-A001B-102	RESISTOR-SEMI FIXED EVN DXA A03 B13 1Kohm
SV2		
SV3		
SV4		
VR1005	VRAE-D018C-203	VR-ROTARY RK12K1130 0A2 23C-20KC

10. FRONT P.C BOARD (A1U-312(B))

Ref. No.	Part No.	Description
L1001	DPLT-00073-YC3	DOT-LED
L1011		SLR-34YC3 YEL R3 TAPPING
L1012	DPLT-00311-WW5	DOT-LED
L1013		SPR-54MVW (2COLOR) R5 D
L1014		
L1015		
L1016		
S1009	SWTA-00220-060	SWITCH-TACT SKHV10910 (A) 12V 50mA
S1010		
S1011		
S1012		
S1013		
S1014		[AC-405K]
S1015		
S1016		
S1017		
S1018		
S1019		
S1020		
S1021		
S1022		
S1023		
S1024		

Q1038	TRTA-0043E-SOS	TRANSISTOR P-H FREQ DTA114E-S W/RESIST TO92M
Q1028	TRTC-0061E-SOS	TRANSISTOR N-H FREQ DTC124E-S TO92M
Q1029		
Q1030		
Q1031		
Q1032		
Q1033		
Q1034		

11. VOLUME LED P.C BOARD

Ref. No.	Part No.	Description
L1020	DPLT-00452-YC5	DOT-LED AL-151YC YEL R5 N

12. PHONES P.C BOARD(A1U-312(D))

Ref. No.	Part No.	Description
R1088	RMOE-H391J-020	RESISTOR-METAL OXIDE 1W ERG(X) 1SJ391E 390ohm T
R1089		
JK1003	SKPH-00360-360	SOCKET-PHONE HTJ035-10A

13. MIC JACK PCB (A1U-312(C))

Ref. No.	Part No.	Description
JK1001	SKPH-00350-360	SOCKET-PHONE LGY6501-06
JK1002		[AC-405K]

14. CD P.C BOARD (A2U-154)

Ref. No.	Part No.	Description
D602	DDTZ-G056B-SO0	DIODE ZENER MTZ5.6B 5.45-5.73 DO40 T
D607	DDTZ-G062B-SO0	DIODE ZENER MTZ6.2B 5.96-6.27 DO40 T
IC606	ICDG-00340-SO0	IC MOTOR DRIVER BA6209 DIP10H
IC602	ICDG-00940-SE0	IC D.S.P + D.A.C (CDP) KS-9282B QFP80
IC601	ICDG-00950-SE0	IC RF + SERVO (CDP) KA-9220B QFP80
IC603	ICLN-01590-SE0	IC MOTOR CONTROL CDP KA-9258D HSOP28
IC604	ICOP-00130-SE0	IC DUAL OP AMP KA4558S SIP9
IC605	PCB-CDP	PCB-SINGLE A2U-154 247 x 247 x 1.6t
Q602	TRSA-0023Y-SD0	TRANSISTOR P-H FREQ KTA1658-Y TO220IS
Q614		
Q601	TRTA-0008G-SD0	TRANSISTOR P-H FREQ KTA1266-GR TO92
Q604		
Q606	TRTA-0042E-SOS	TRANSISTOR P-H FREQ DTA124E-S TO92M
Q610		
Q603	TRTC-0016G-SD0	TRANSISTOR N-H FREQ KTC3198-GR TO92
Q608	TRTC-0016Y-SD0	TRANSISTOR N-H FREQ KTC3198-Y TO92
Q609		
Q605	TRTC-0034Y-SOS	TRANSISTOR N-H FREQ DTC114Y-S TO92
Q607		
Q611		
Q615		

Ref. No.	Part No.	Description
IC607	ICCM-20501-S30	IC CMOS TC4094B DIP16
Q612	TRTD-00200-SD0	TRANSISTOR N-L FREQ KTD-1302 TO92
Q613		
SV601	VFEB-A001B-223	RESISTOR-SEMI FIXED EVN DXA A03 BE4 22Kohm
SV602		
SV603		
SV604		

15. P.C BOARD BLOCK

Ref. No.	Part No.	Description
1	PCSU-03120-11B	FRONT P.C BOARD A1U-312 197 × 247 × 1.6t
2	PCSU-03110-11B	MAIN P.C BOARD A1U-311 247 × 330 × 1.6t
3	PCSU-03100-15B	AMP/ECHO P.C BOARD A1U-310 197 × 247 × 1.6t
4	PCSU-01540-21B	CDP P.C BOARD A2U-154 247 × 247 × 1.6t
5	PCSU-01650-25B	SUB P.C BOARD [U, Y] A2U-165 163 × 163 × 1.6t

16. SUB PCB (A2U-165) [U, Y] only

Ref. No.	Part No.	Description
F2	* FGFB-S8001-337	FUSE GLASS 800mA 250V 5 × 20
F1	* FGFB-S1002-337	FUSE GLASS 1A 250V 5 × 20

17. ACCESSARY

Ref. No.	Part No.	Description
1	A2RC-E4000-01E	REMOTE BOX RC-S400
2	BAMN-AAM00-150	BATTERY MANGANESE R6P 1.5V 14.5 × 50.5
3	YICC-E4000-01E	INST-MANUAL
4	ANTL-00060-E50	ANTENNA-LOOP AAN-007 19.5μH 7T 125 × 93
5	ANTW-00020-202	ANTENNA-WIRE AFN-002 1007#24-2000mm

EXPLODED VIEW

16. FINAL ASSEMBLY

AC-400 [E/B/S/V Version]

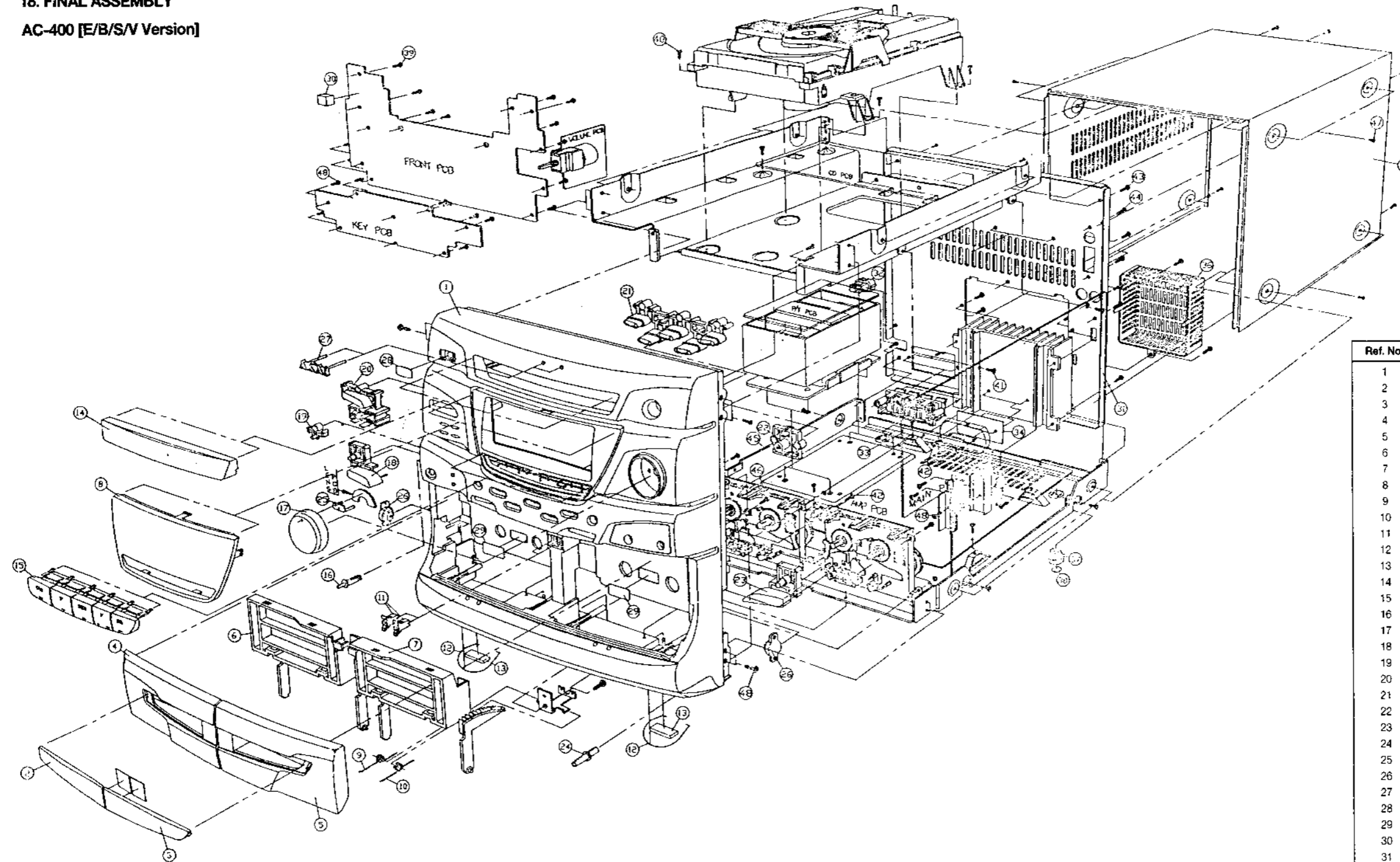

Ref. No.	Part No.	Description
1	MJAF-03820-ZZ1	FRONT-PANEL
2	MJAF-05370-ZZ3	DOOR-WINDOW-L
3	MJAF-05380-ZZ3	DOOR-WINDOW-R
4	MJAF-02400-ZZ2	DOOR-CAP-L
5	MJAF-02410-ZZ2	DOOR-CAP-R
6	MJAF-02460-ZZ2	DOOR-DECK-L
7	MJAF-02470-ZZ2	DOOR-DECK-R
8	MAAF-05490-ZZ3	WINDOW-FL
9	MMAC-13470-004	SPRING-EJECT-L
10	MMAC-13480-004	SPRING-EJECT-R
11	MJAG-00840-003	PUSH-LATCH
12	MMAC-13490-004	FOOT-RING
13	MRAG-09140-004	CUSHION-FOOT
14	MJAF-05250-ZZ3	DOOR-CD
15	MJAF-05460-ZZ3	KNOB-MAGIC
16	MJAF-12570-ZZ4	KNOB-SURROUND
17	MJAF-12230-ZZ4	KNOB-VOLUME
18	MJAF-12520-ZZ4	KNOB-SOUND CHARACTOR
19	MJAF-12560-ZZ4	KNOB-SUPER BASS
20	MJAF-05480-ZZ3	KNOB-POWER
21	MJAF-05470-ZZ3	KNOB-OPERATION
22	MJAF-12550-ZZ4	KNOB-OPEN, CLOSE
23	MJAF-12510-ZZ4	KNOB-DOLBY
24	MJAF-12540-ZZ4	KNOB-MIXING
25	MJAF-12260-ZZ4	LENS-VOLUME
26	MJAG-08110-004	DAMPER-GEAR
27	MJAF-12580-ZZ4	BADGE-AKAI
28	MAAF-12350-ZZ4	PLATE-REMOTE
29	MGAF-04940-ZZ4	REFLECTOR-TAPE
30	MRAG-10910-004	CUSHION-REMOTE
31	MPAC-03390-ZZ2	CHASSIS-BACK
32	MJAG-00281-003	BUSH-CORD
33	MRAG-11080-004	CUSHION-PCB
34	MRAG-07451-004	RUBBER-IC-L
35	MPAC-03691-ZZ1	COVER-TOP
36	MJAG-00250-002	COVER-RADIATOR
37	MJAF-07620-ZZ4	FOOT
38	MRAG-07030-004	CUSHION-FOOT
39	XSTB-30100-ZY4	SCREW-TAPPING
40	XSTB-30080-ZY8	SCREW-TAPPING
41	XSTW-30080-ZY4	SCREW-TAPPING
42	XSTB-30140-ZY4	SCREW-TAPPING
43	XSTB-30080-ZB4	SCREW-TAPPING
44	XSTB-30120-ZB4	SCREW-TAPPING
45	XSTB-40080-ZY8	SCREW-TAPPING
46	XSTW-30100-ZY4	SCREW-TAPPING
47	XSTB-40080-ZB8	SCREW-TAPPING
48	XSTB-30080-ZY4	SCREW-TAPPING

EXPLODED VIEW

AC-400 [U/Y Version]

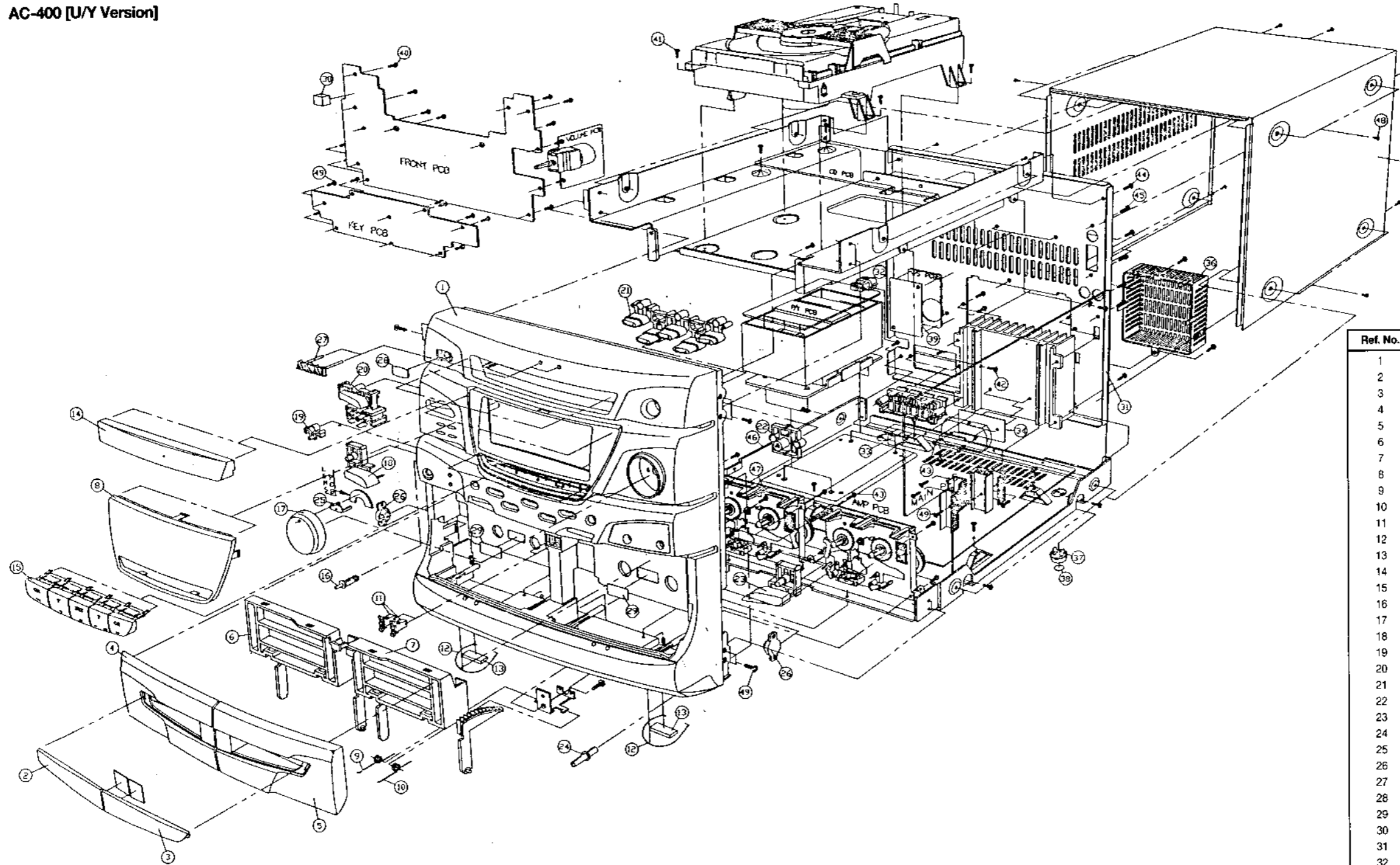

Ref. No.	Part No.	Description
1	MJAF-03820-ZZ1	FRONT-PANEL
2	MJAF-05370-ZZ3	DOOR-WINDOW-L
3	MJAF-05380-ZZ3	DOOR-WINDOW-R
4	MJAF-02400-ZZ2	DOOR-CAP-L
5	MJAF-02410-ZZ2	DOOR-CAP-R
6	MJAF-02460-ZZ2	DOOR-DECK-L
7	MJAF-02470-ZZ2	DOOR-DECK-R
8	MAAF-05490-ZZ3	WINDOW-FL
9	MMAC-13470-004	SPRING-EJECT-L
10	MMAC-13480-004	SPRING-EJECT-R
11	MJAG-00840-003	PUSH-LATCH
12	MMAC-13490-004	FOOT-RING
13	MRAG-09140-004	CUSHION-FOOT
14	MJAF-05250-ZZ3	DOOR-CD
15	MJAF-05460-ZZ3	KNOB-MAGIC
16	MJAF-12570-ZZ4	KNOB-SURROUND
17	MJAF-12230-ZZ4	KNOB-VOLUME
18	MJAF-12520-ZZ4	KNOB-SOUND CHARACTOR
19	MJAF-12560-ZZ4	KNOB-SUPER BASS
20	MJAF-05480-ZZ3	KNOB-POWER
21	MJAF-05470-ZZ3	KNOB-OPERATION
22	MJAF-12550-ZZ4	KNOB-OPEN, CLOSE
23	MJAF-12510-ZZ4	KNOB-DOLBY
24	MJAF-12540-ZZ4	KNOB-MIXING
25	MJAF-12260-ZZ4	LENS-VOLUME
26	MJAG-08110-004	DAMPER-GEAR
27	MJAF-12580-ZZ4	BADGE-AKAI
28	MAAF-12350-ZZ4	PLATE-REMOTE
29	MGAF-04940-ZZ4	REFLECTOR-TAPE
30	MRAG-10910-004	CUSHION-REMOTE
31	MPAC-03420-ZZ2	CHASSIS-BACK
32	MJAG-00281-003	BUSH-CORD
33	MRAG-11080-004	CUSHION-PCB
34	MRAG-07451-004	RUBBER-IC-L
35	MPAC-03691-ZZ1	COVER-TOP
36	MJAG-00250-002	COVER-RADIATOR
37	MJAF-07620-ZZ4	FOOT
38	MRAG-07030-004	CUSHION-FOOT
39	MAAG-10980-004	INSULATOR-V/S
40	XSTB-30100-ZY4	SCREW-TAPPING
41	XSTB-30080-ZY8	SCREW-TAPPING
42	XSTW-30080-ZY4	SCREW-TAPPING
43	XSTB-30140-ZY4	SCREW-TAPPING
44	XSTB-30080-ZB4	SCREW-TAPPING
45	XSTB-30120-ZB4	SCREW-TAPPING
46	XSTB-40080-ZY8	SCREW-TAPPING
47	XSTW-30100-ZY4	SCREW-TAPPING
48	XSTB-40080-ZB8	SCREW-TAPPING
49	XSTB-30080-ZY4	SCREW-TAPPING

VII. BLOCK DIAGRAM/FRONT

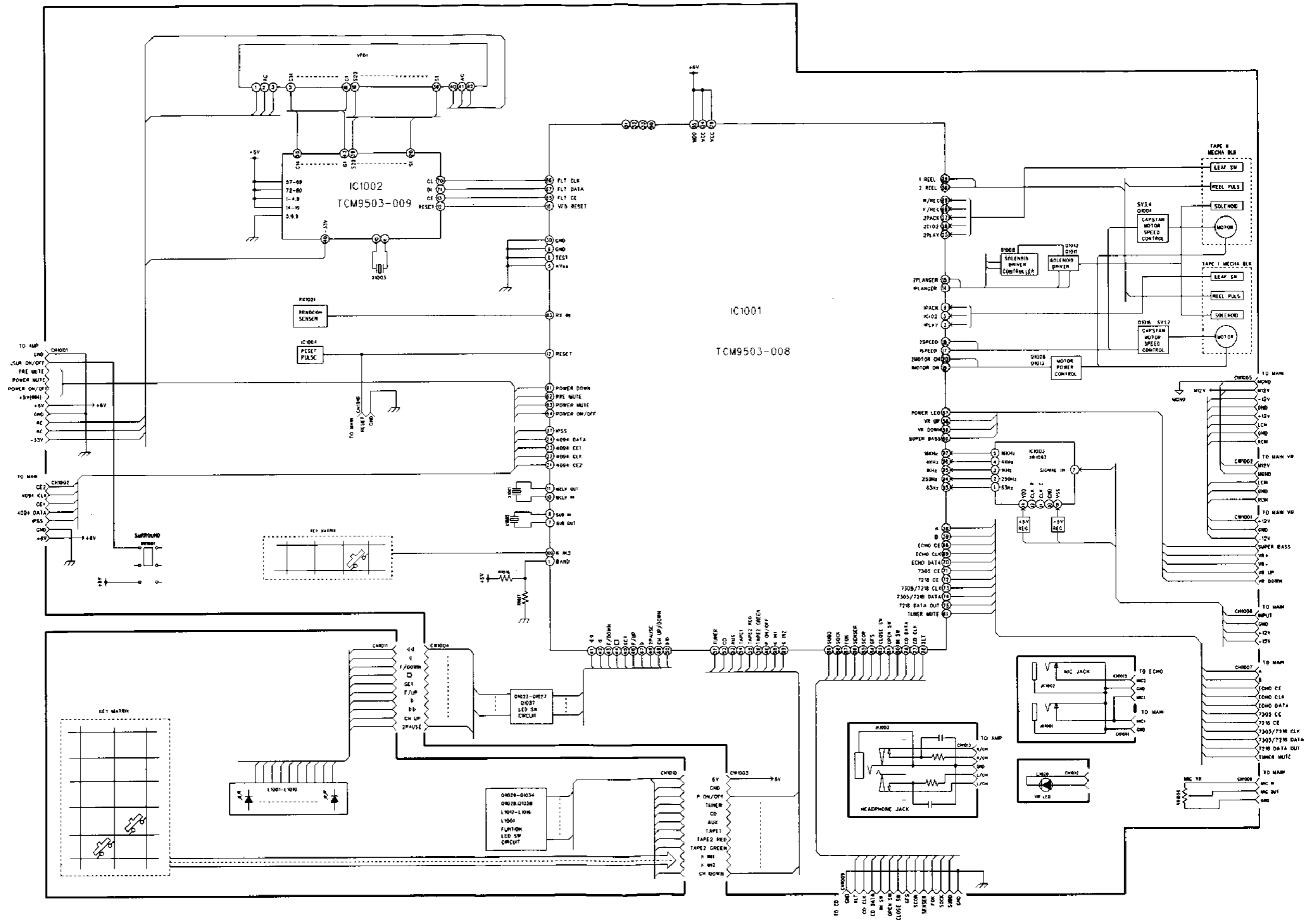

BLOCK DIAGRAM/AMP, DECK

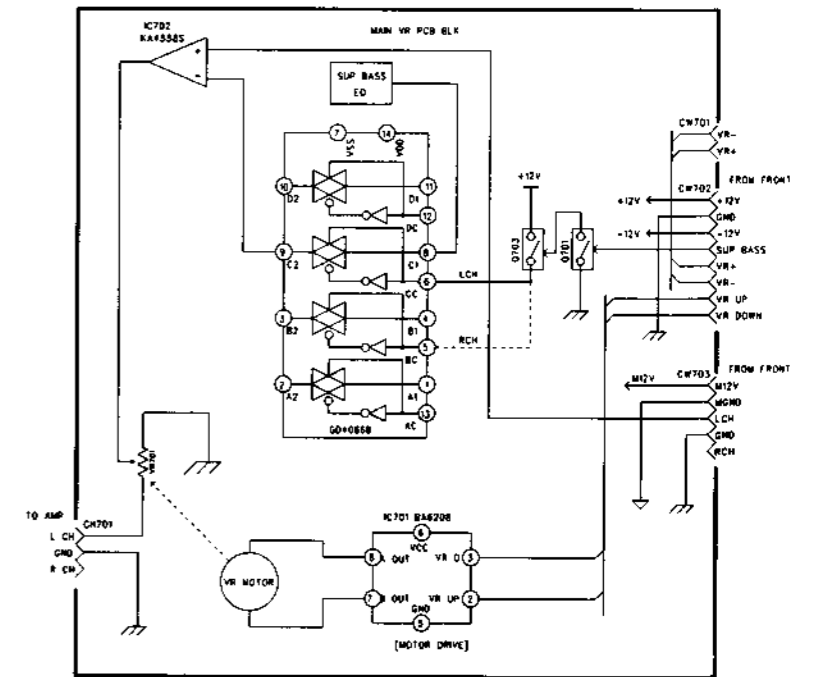
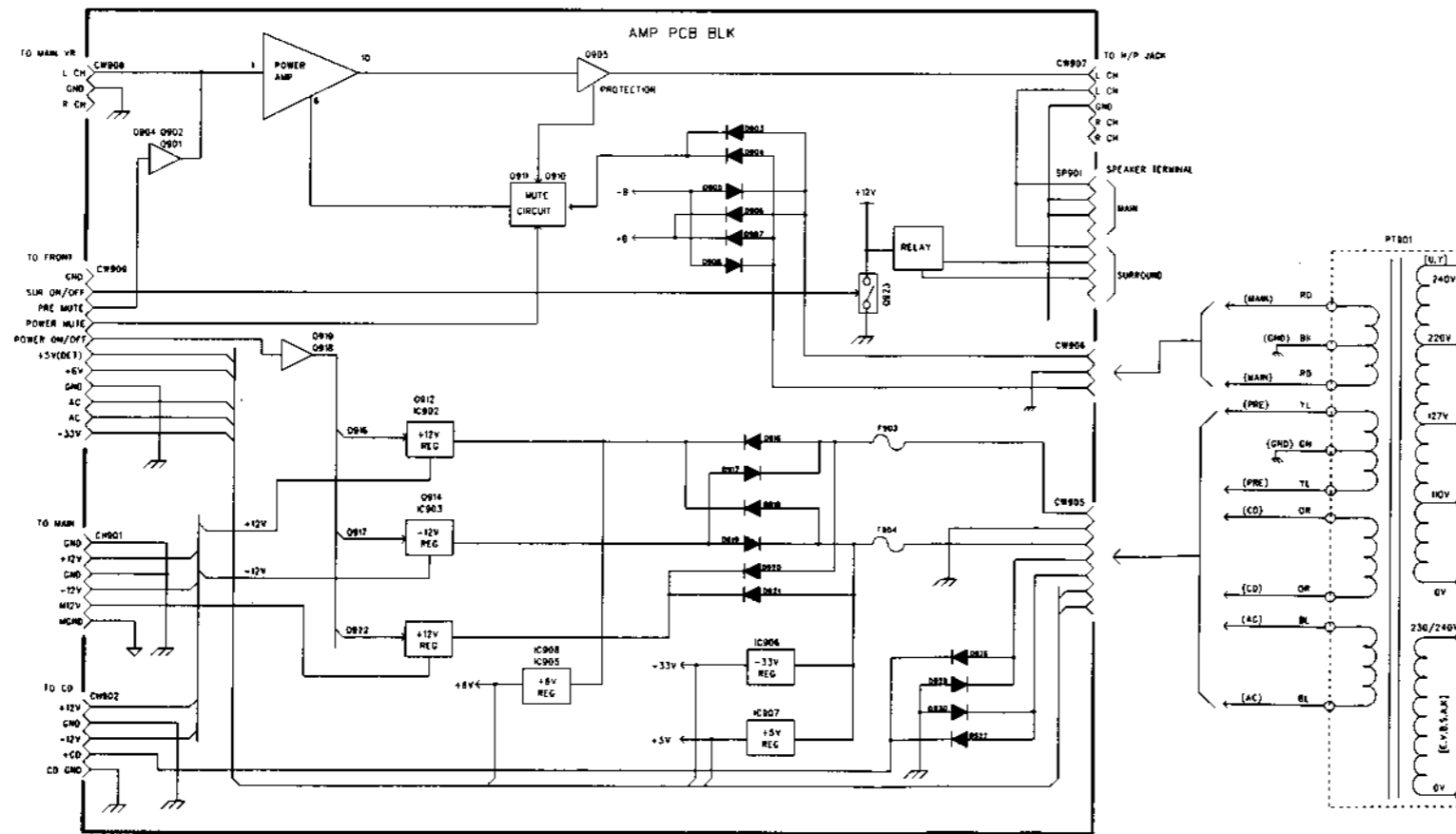
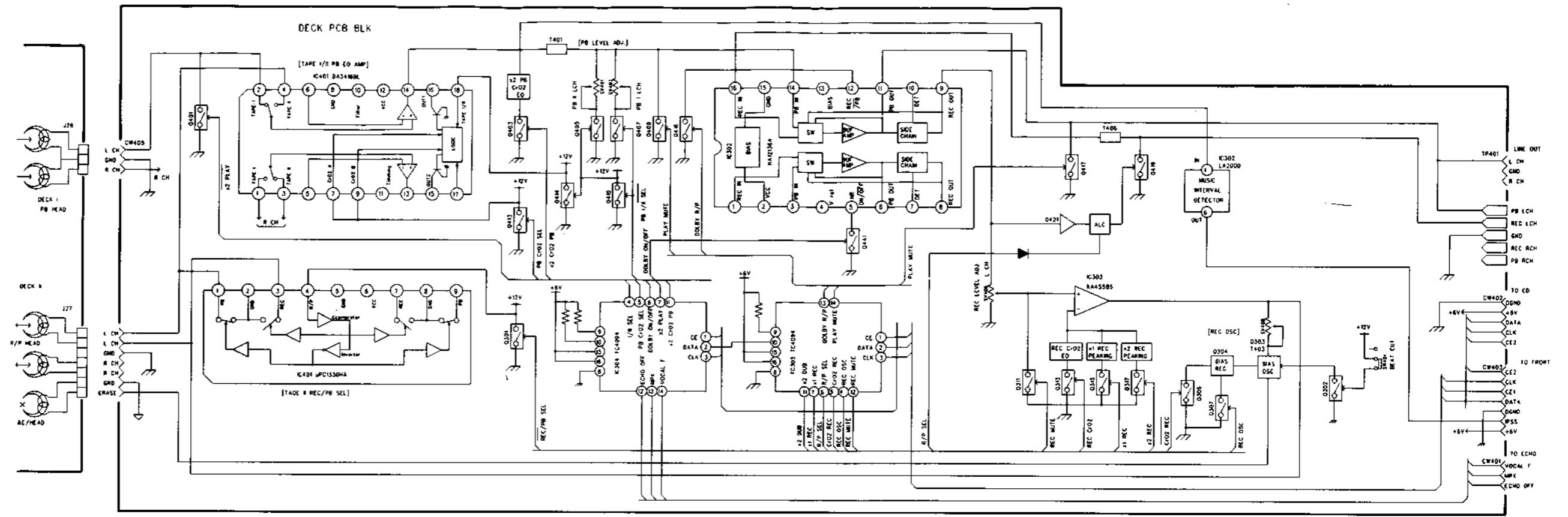

VIII. SCHEMATIC DIAGRAM/FRONT

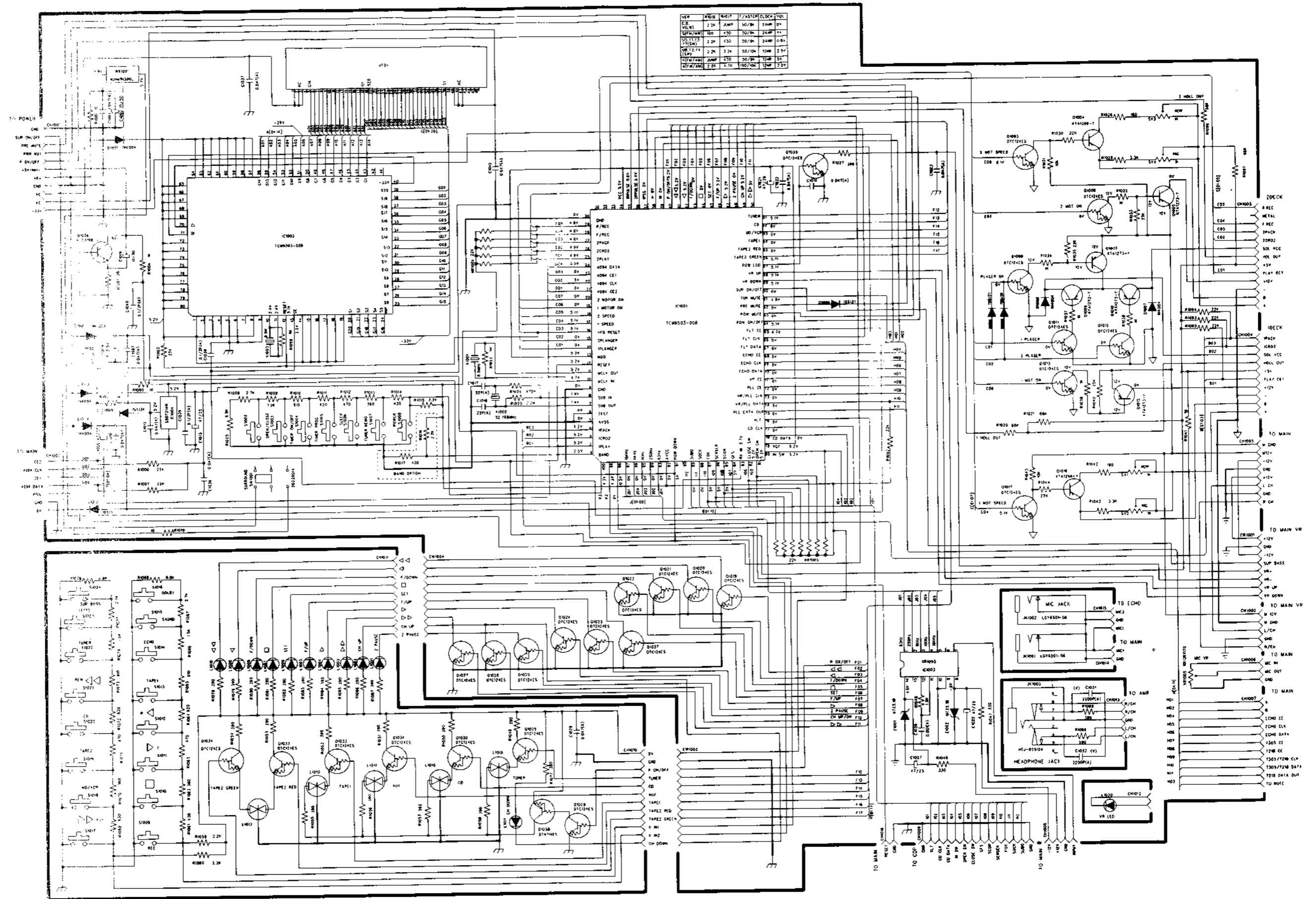

BLOCK DIAGRAM/CD

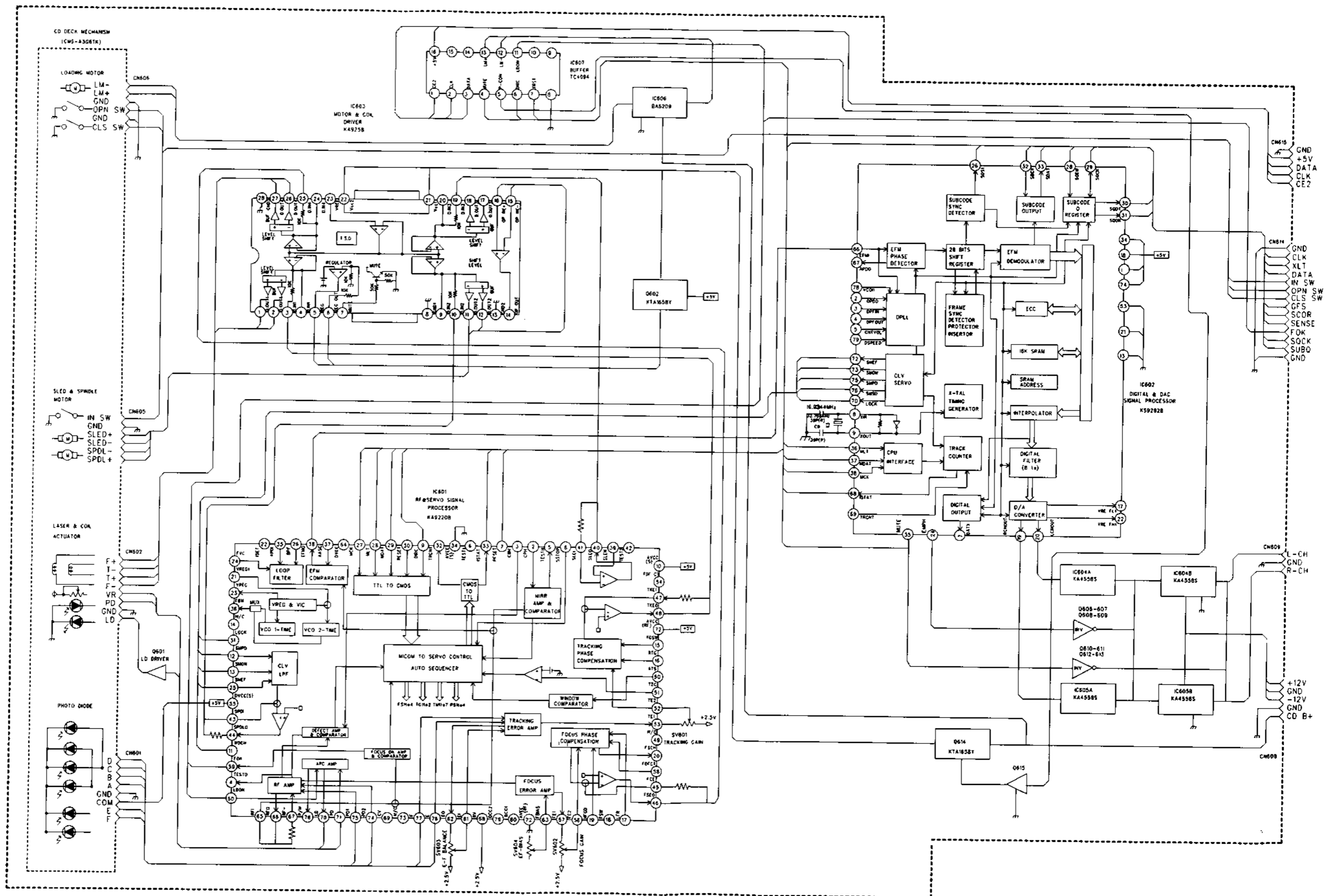

SCHEMATIC DIAGRAM/DECK

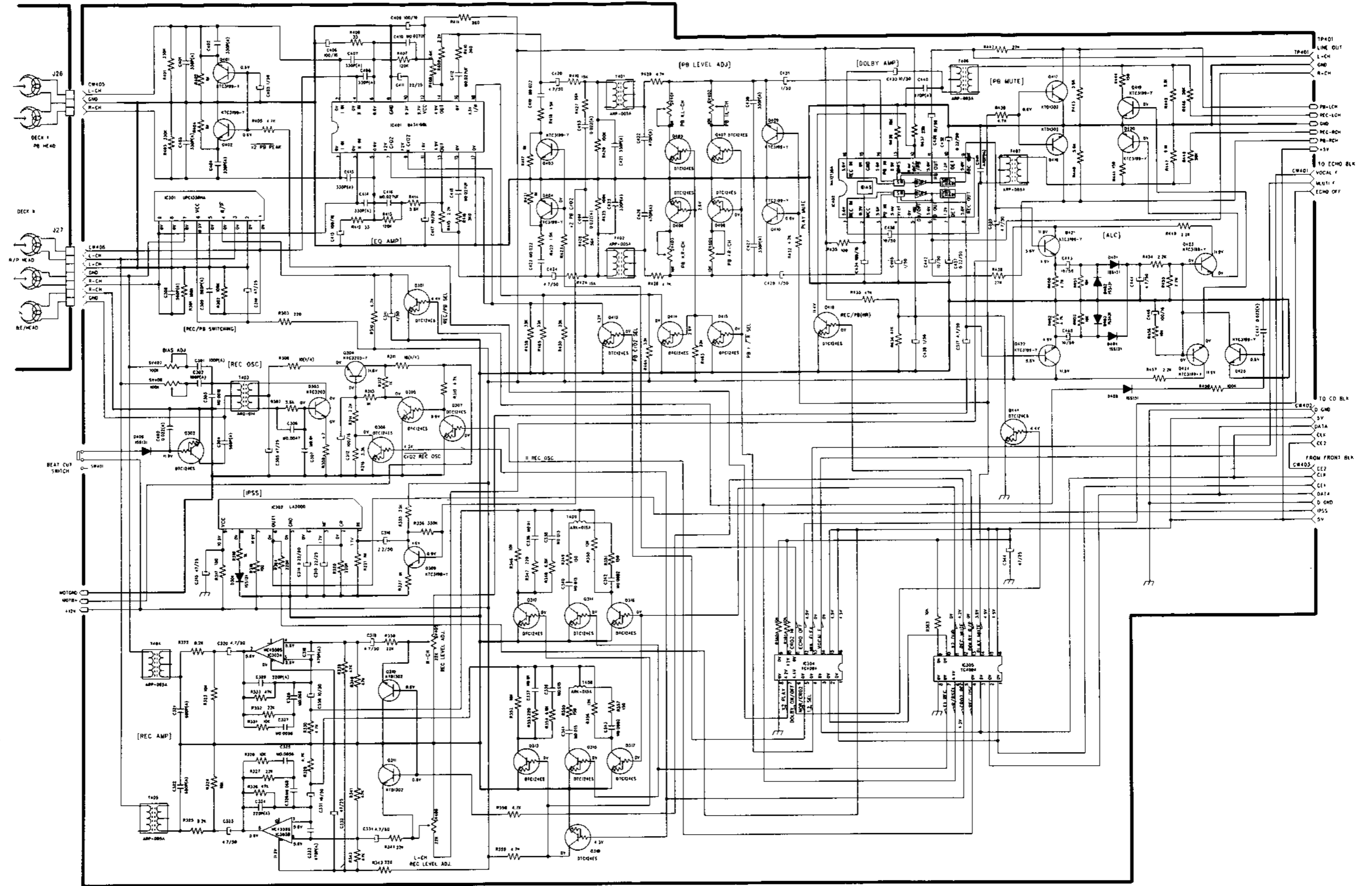

SCHEMATIC DIAGRAM/FUNCTION/G-EQ

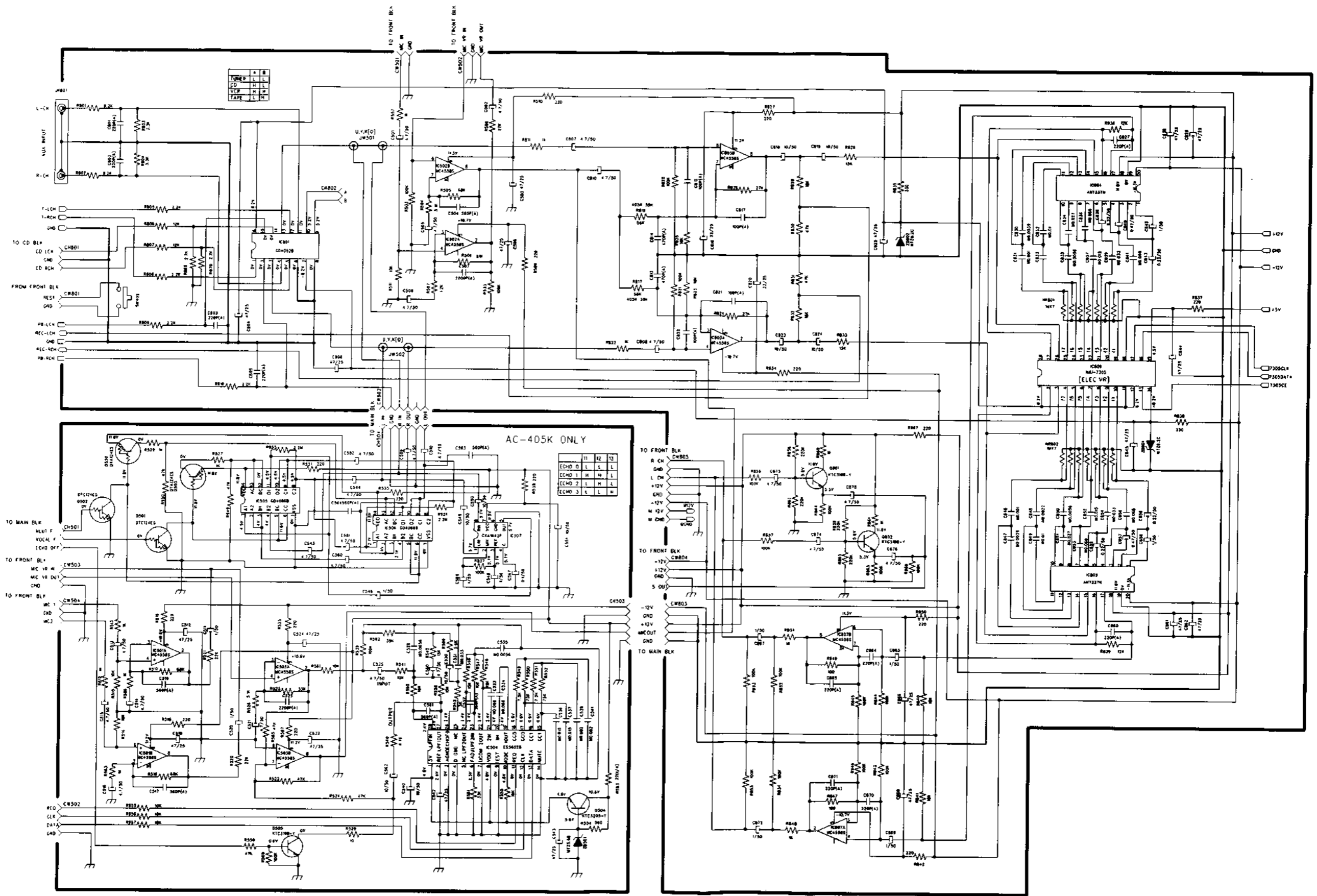

SCHEMATIC DIAGRAM/TUNER, MAIN, VR

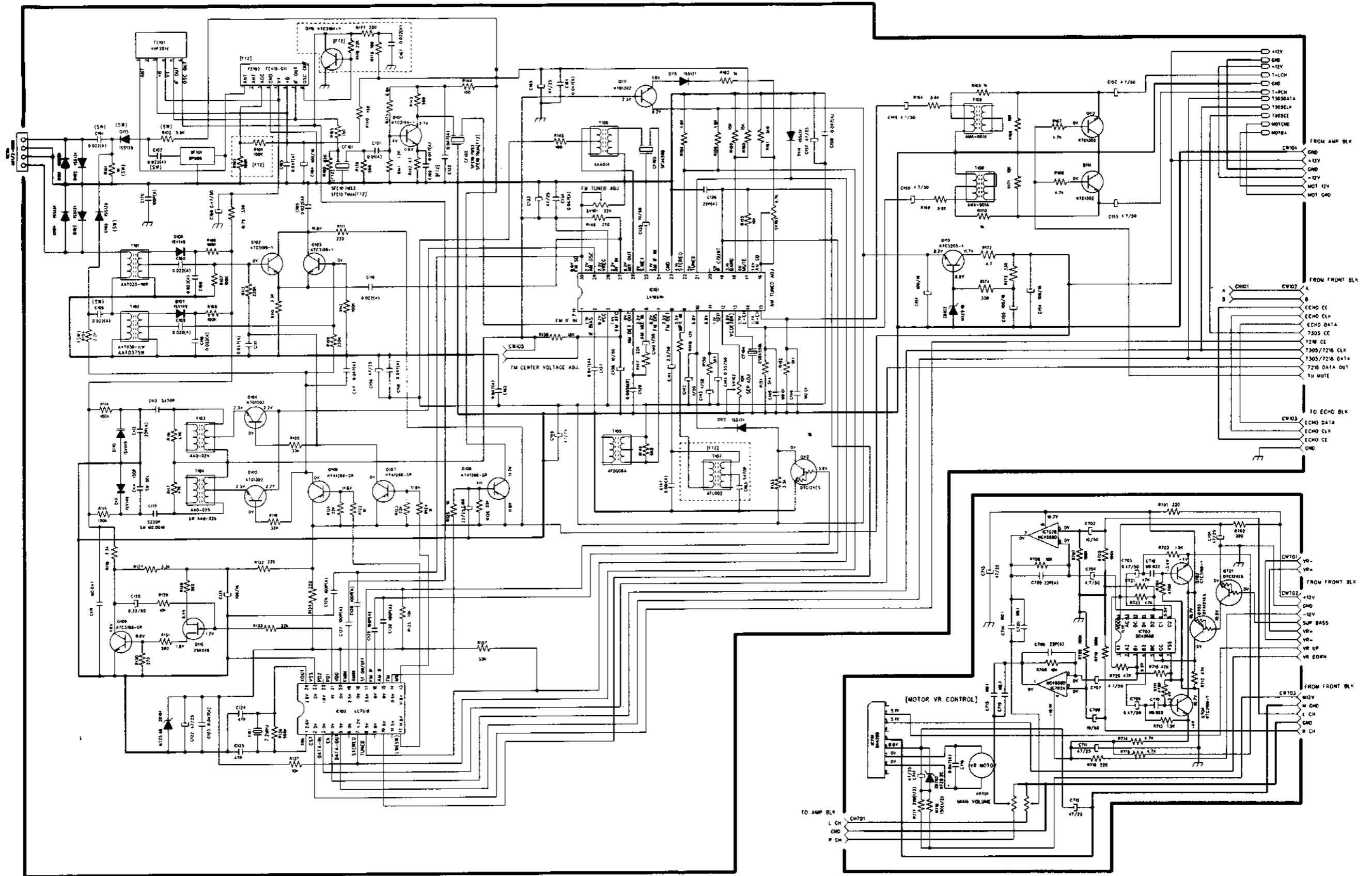

SCHEMATIC DIAGRAM/POWER AMP

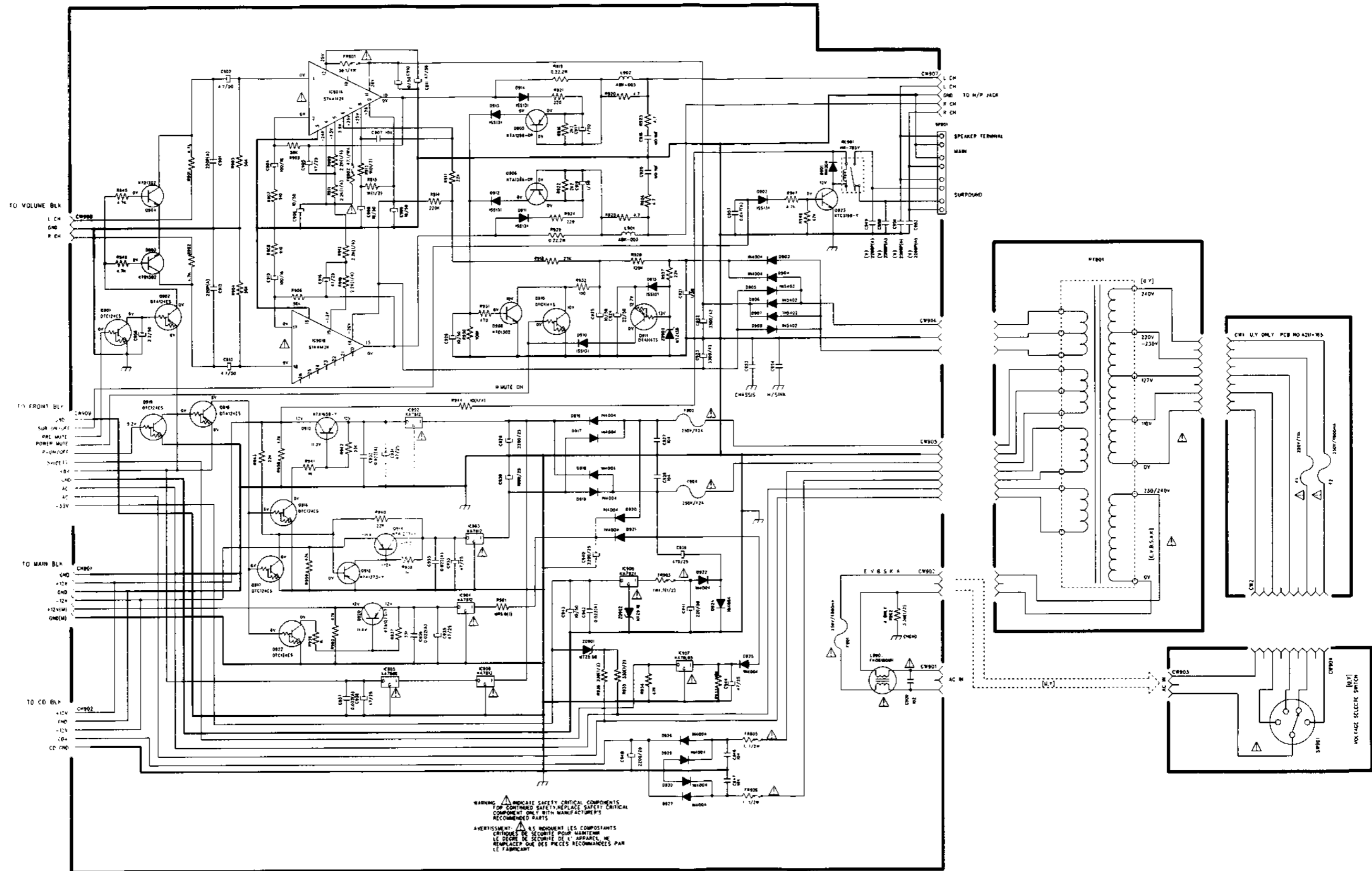

SCHEMATIC DIAGRAM/CD

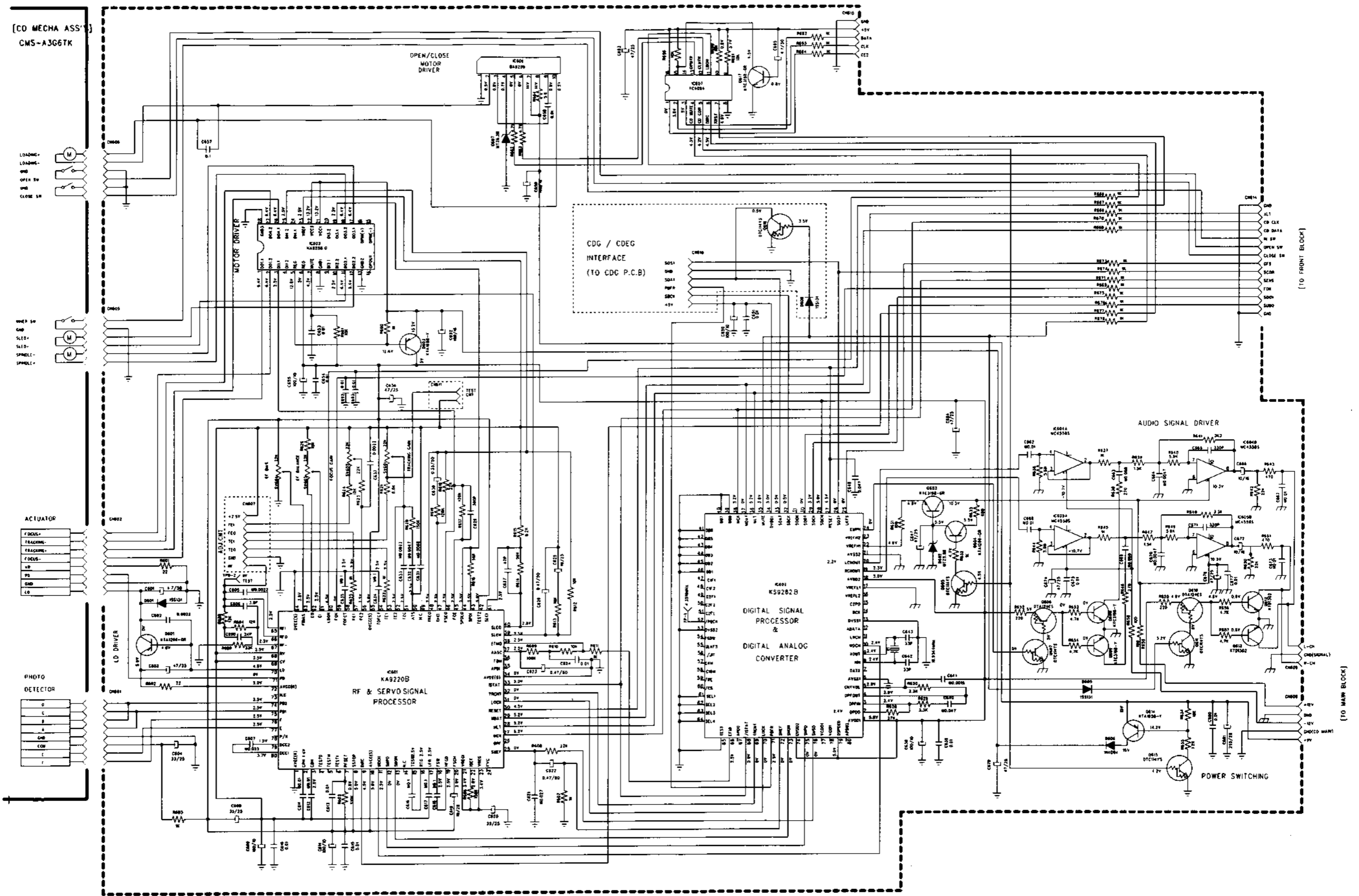

SCHEMATIC DIAGRAM/REMOTE

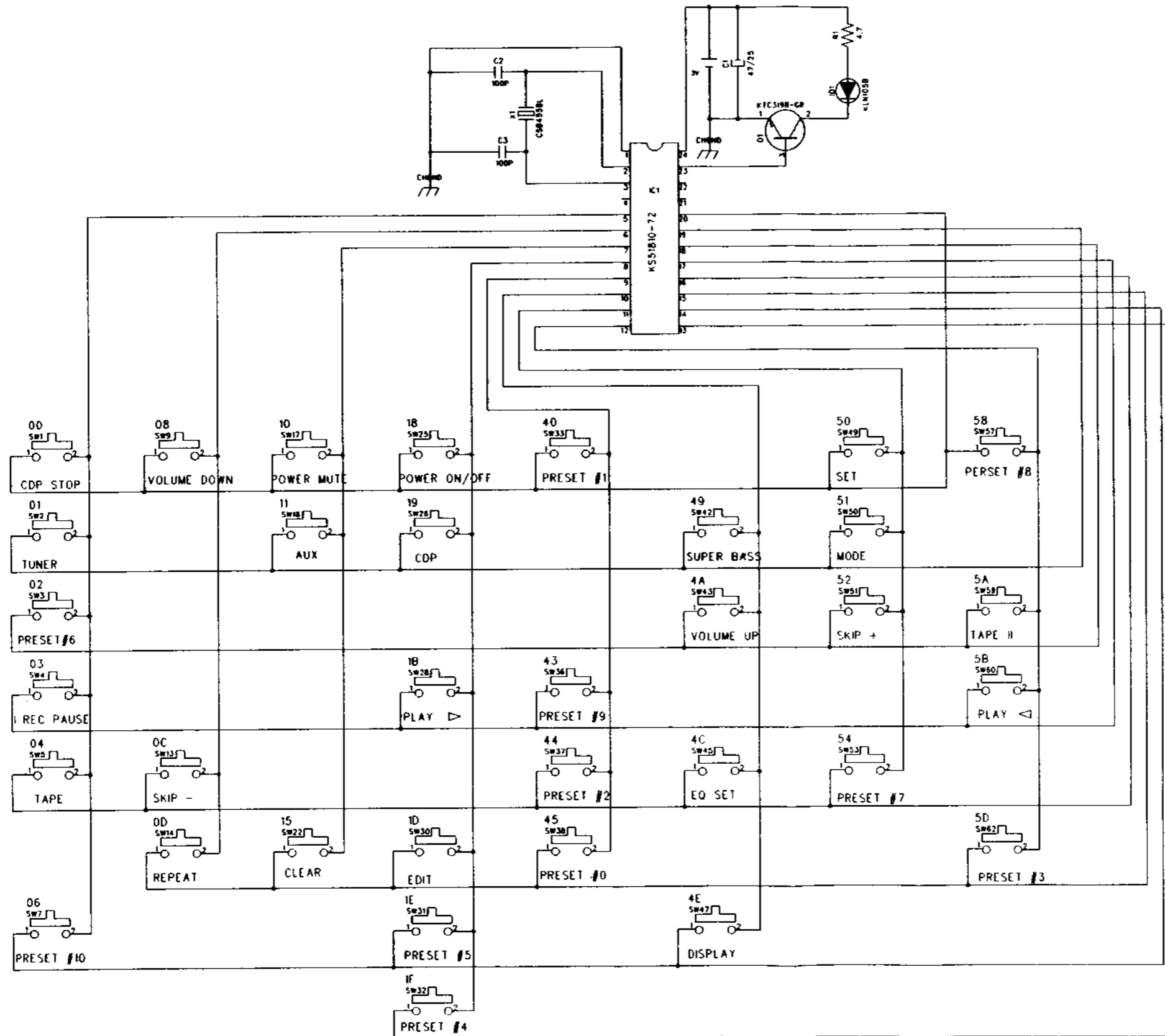

HEX	NO	FUNCTIN
00	K1	CDP STOP
01	K2	TUNER
02	K3	PRESET #6
03	K4	REC PAUSE
04	K5	TAPE
06	K7	PRESET #10
08	K9	VOLUME DOWN
0C	K13	SKIP -
0D	K14	REPEAT
10	K17	POWER MUTE
11	K18	AUX
15	K22	CLEAR
18	K25	POWER ON/OFF
19	K26	CDP
1B	K28	PLAY ▷
1D	K30	EDIT
1E	K31	PRESET #5
1F	K32	PRESET #4
40	K33	PRESET #1
43	K36	PRESET #9
44	K37	PRESET #2
45	K38	PRESET #0
49	K42	SUPER BASS
4A	K43	VOLUME UP
4C	K45	EQ SET
4E	K47	DISPLAY
50	K49	SET
51	K50	MODE
52	K51	SKIP +
54	K53	PRESET #7
58	K57	PRESET #8
5A	K59	TAPE II
5B	K60	PLAY ◁
5D	K62	PRESET #3

IX. PCB LAYOUT/MAIN

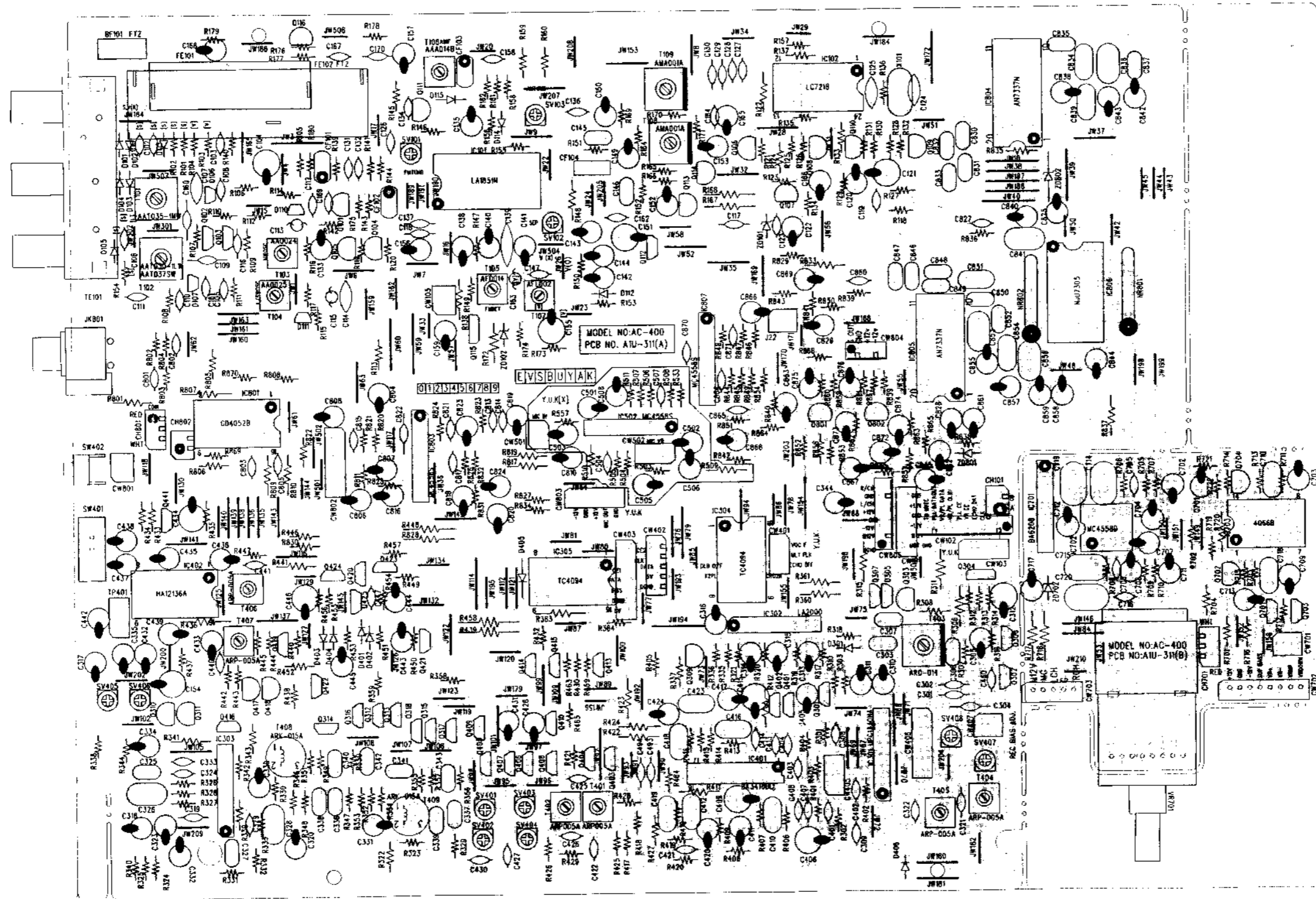

MODEL	AC-400				K05K405				REMARK
	VER	FM	MW	LW	FM	MW	LW	SW	
JW184	0	0	0	0	0	0	0	0	JUMP
JW301	0	0	0	0	0	0	0	0	JUMP
JW302	0	0	0	0	0	0	0	0	JUMP
JW501	0	0	0	0	0	0	0	0	JUMP
JW502	0	0	0	0	0	0	0	0	JUMP
C101	0	0	0	0	0	0	0	0	223
C102	0	0	0	0	0	0	0	0	223
R101	0	0	0	0	0	0	0	0	1K
R102	0	0	0	0	0	0	0	0	5K6
D105	0	0	0	0	0	0	0	0	ISS135
D113	0	0	0	0	0	0	0	0	ISS135
FE101	0	0	0	0	0	0	0	0	KHF201V(V2)
FE102	0	0	0	0	0	0	0	0	FE415-G11(V1)
BF101	0	0	0	0	0	0	0	0	BF-MB6
R103	0	0	0	0	0	0	0	0	100K(V1)
R104	0	0	0	0	0	0	0	0	100K(V1)
R104	0	0	0	0	0	0	0	0	150(V1-JUMP)
R104	0	0	0	0	0	0	0	0	150(V1-JUMP)
CF101	0.750	750	7.00	750	750	750	750	75	V2:10.75
CF102	0.750	750	7.00	750	750	750	750	75	V2:10.75
C106	0	0	0	0	0	0	0	0	223
R154	0	0	0	0	0	0	0	0	2K2
T102	50	10	100	1	0	0	0	0	0.37
O107	0	0	0	0	0	0	0	0	15V149
R108	0	0	0	0	0	0	0	0	100K
C109	0	0	0	0	0	0	0	0	223
C110	0	0	0	0	0	0	0	0	223
R109	0	0	0	0	0	0	0	0	100K
Q103	0	0	0	0	0	0	0	0	C3189Y
R112	0	0	0	0	0	0	0	0	100K
C126	0	0	0	0	0	0	0	0	100P
C117	0	0	0	0	0	0	0	0	473
R115	0	0	0	0	0	0	0	0	100K
D111	0	0	0	0	0	0	0	0	15V149
C114	0	0	0	0	0	0	0	0	150P
C115	52205	2205	220	220	0	0	0	0	47K
R117	0	0	0	0	0	0	0	0	47K
T104	0.25	0.25	0.25	0	0	0	0	0	0.26
O105	0	0	0	0	0	0	0	0	D1302
Q106	0	0	0	0	0	0	0	0	A1266
R119	0	0	0	0	0	0	0	0	33K
R119	0	0	0	0	0	0	0	0	22K
R121	0	0	0	0	0	0	0	0	1K
R122	0	0	0	0	0	0	0	0	1K
T107	0	0	0	0	0	0	0	0	AF1002(V1)
C163	0	0	0	0	0	0	0	0	S470P(V1)
CW802	0	0	0	0	0	0	0	0	5267-06
CW803	0	0	0	0	0	0	0	0	5267-05
CW401	0	0	0	0	0	0	0	0	5267-03
CW103	0	0	0	0	0	0	0	0	5267-04
CW501	0	0	0	0	0	0	0	0	5267-02
CW502	0	0	0	0	0	0	0	0	5267-04
R557	0	0	0	0	0	0	0	0	1K
C501	0	0	0	0	0	0	0	0	4.7/50
R511	0	0	0	0	0	0	0	0	10K
IC502	0	0	0	0	0	0	0	0	KA4558S
R503	0	0	0	0	0	0	0	0	100K
R504	0	0	0	0	0	0	0	0	5K1
R505	0	0	0	0	0	0	0	0	68K
C504	0	0	0	0	0	0	0	0	560P
C505	0	0	0	0	0	0	0	0	4.7/50
C502	0	0	0	0	0	0	0	0	4.7/50
R508	0	0	0	0	0	0	0	0	22K
R510	0	0	0	0	0	0	0	0	220
C506	0	0	0	0	0	0	0	0	47/25
R507	0	0	0	0	0	0	0	0	47/25
R507	0	0	0	0	0	0	0	0	51K
R533	0	0	0	0	0	0	0	0	1K2
C507	0	0	0	0	0	0	0	0	100K
R509	0	0	0	0	0	0	0	0	220
C507	0	0	0	0	0	0	0	0	2200P
C508	0	0	0	0	0	0	0	0	4.7/50
R176	0	0	0	0	0	0	0	0	22K(V1)
R177	0	0	0	0	0	0	0	0	330(V1)
R178	0	0	0	0	0	0	0	0	100(V1)
C167	0	0	0	0	0	0	0	0	223(V1)
C168	0	0	0	0	0	0	0	0	223(V1)
JW504	0	0	0	0	0	0	0	0	C3184(V1)
R180	0	0	0	0	0	0	0	0	JUMP(V2-0)
R180	0	0	0	0	0	0	0	0	JUMP(V2-0)
R180	0	0	0	0	0	0	0	0	820(V1)
R189	0	0	0	0	0	0	0	0	473(V1)
R817	56K	56K	56K	56K	39K	39K	56K	56K	
R819	56K	56K	56K	56K	39K	39K	56K	56K	

AC-400 MAIN PCB

PCB NO:A1U-311

AC-400 MAIN PCB

PCB NO:A1U-311

AC-400 MAIN PCB

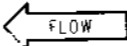

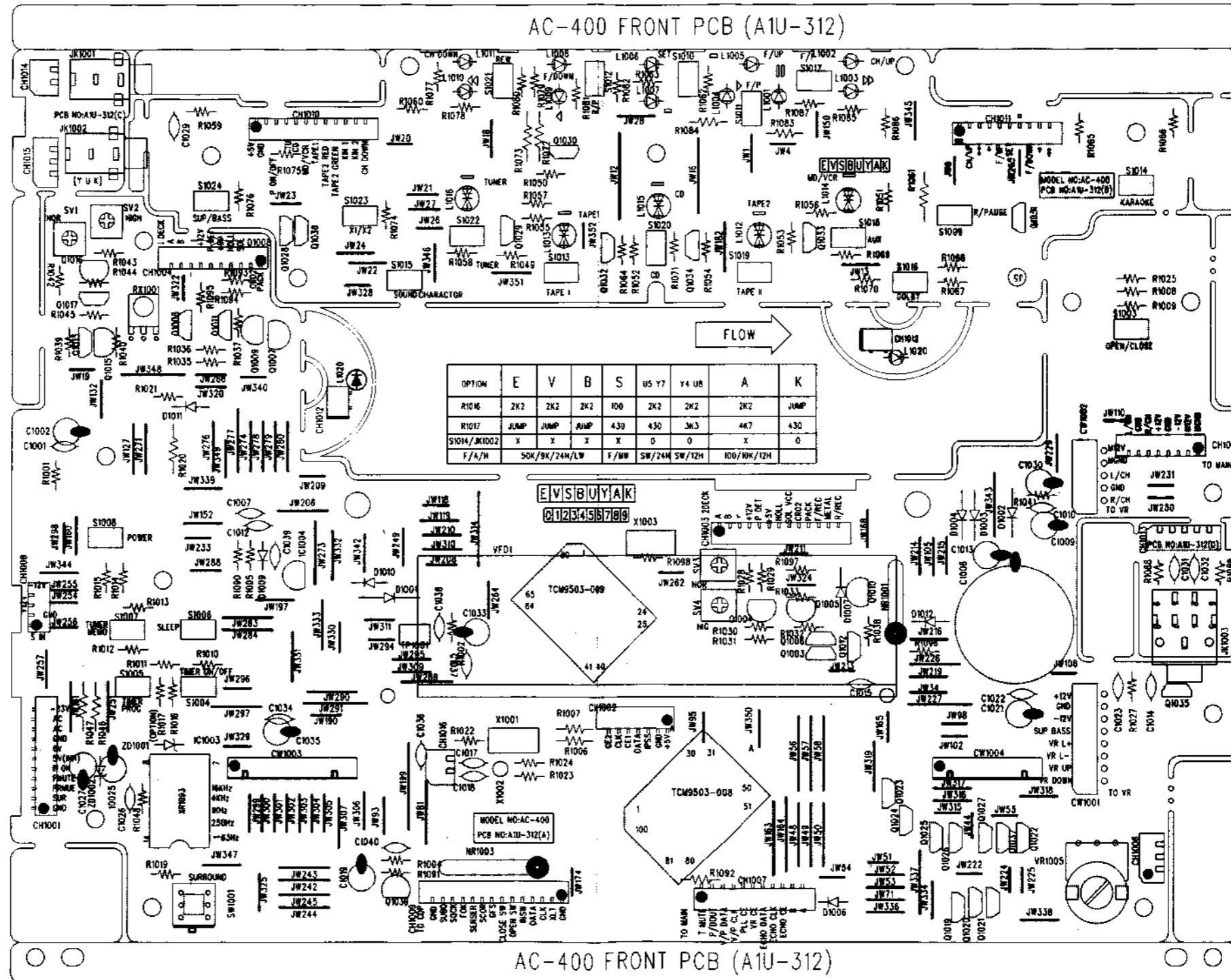

PCB LAYOUT/AMP, ECHO

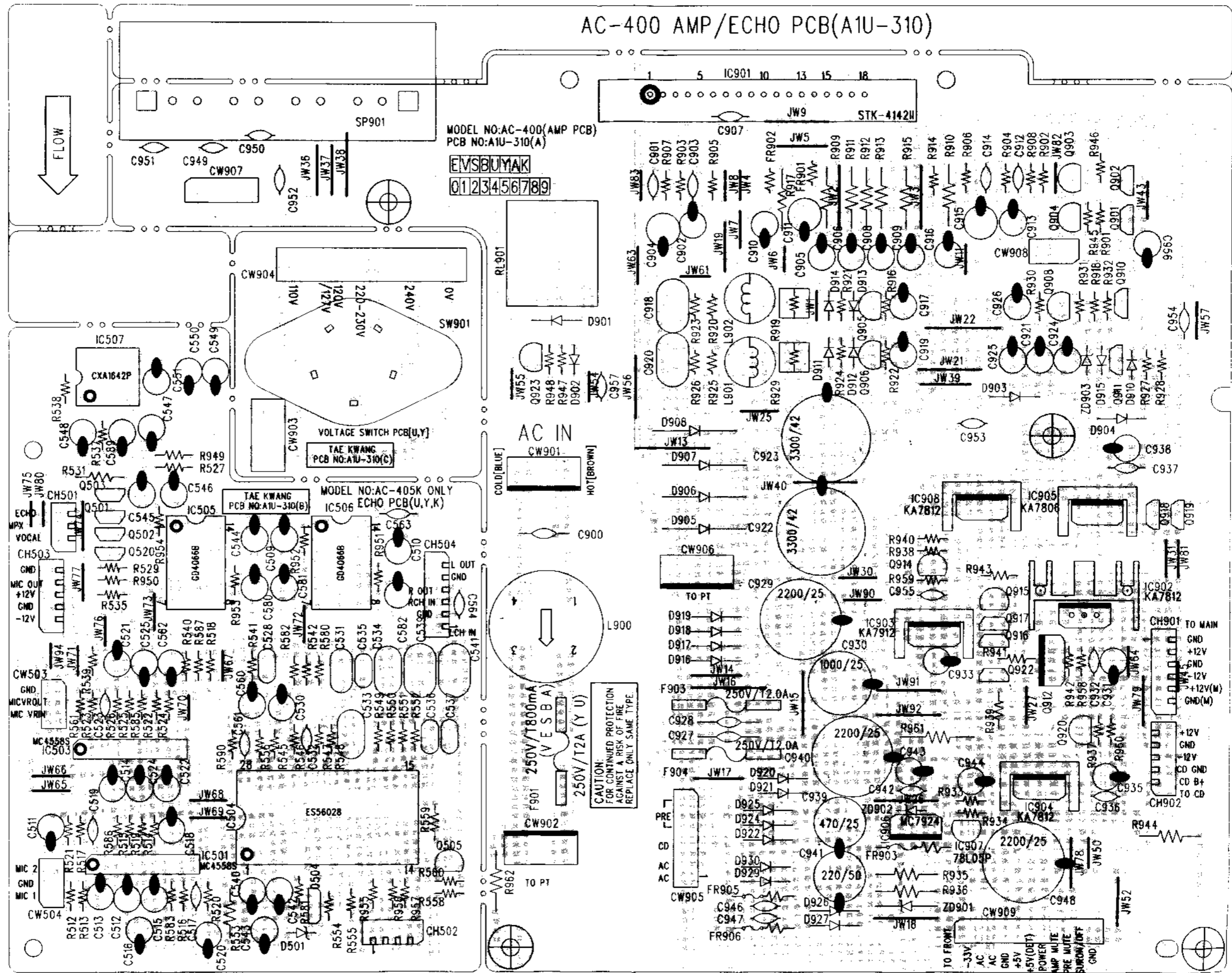

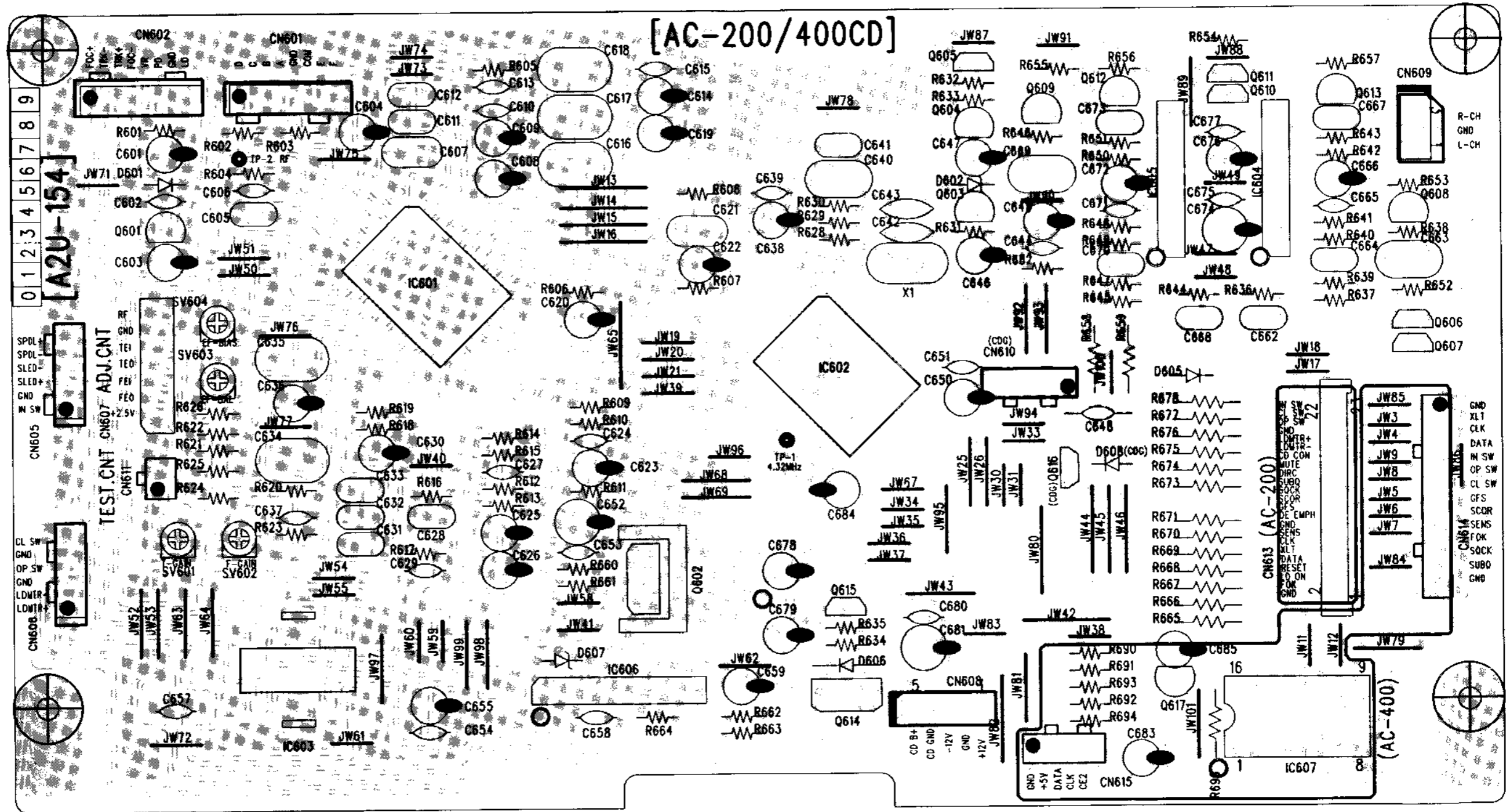

PCB LAYOUT/SUB

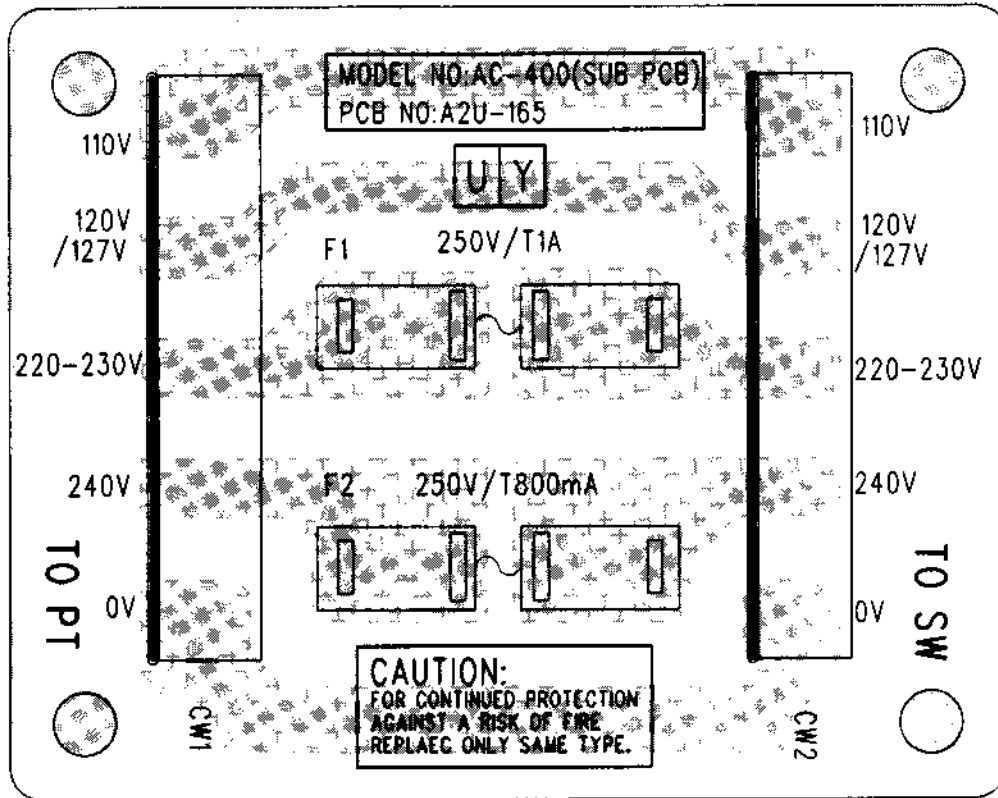

PCB LAYOUT/REMOTE

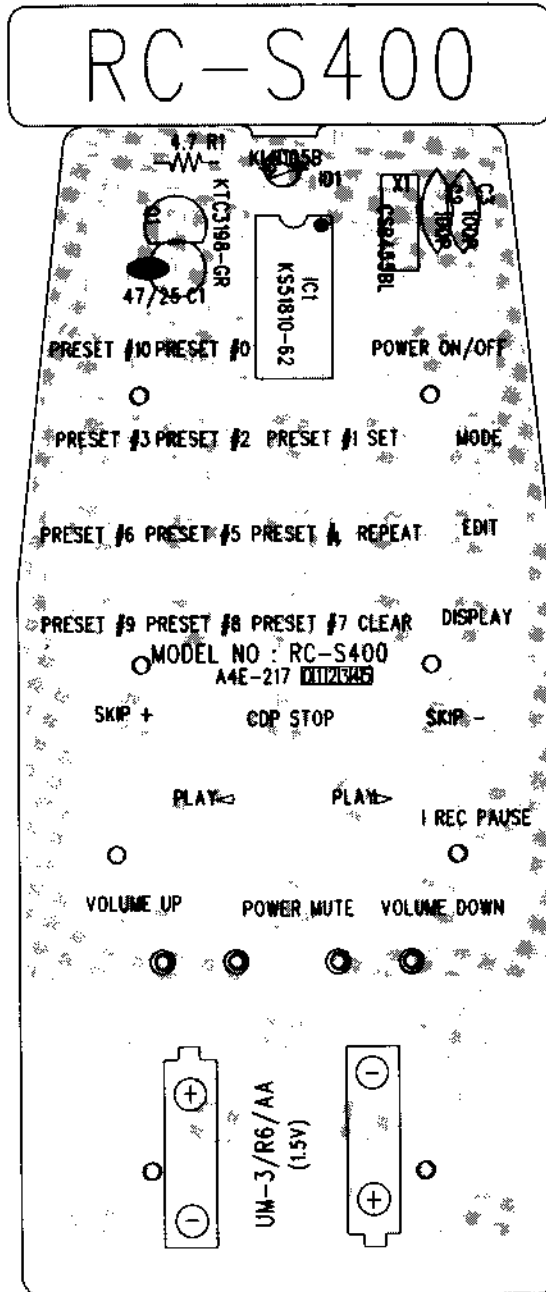

X. INFORMATION OF ICs MI-COM

IC1001 TCM9503-008 (SYSTEM CONTROL μ -COM)

Pin No.	Port Name	I/O	Description
1	BAND	I	Key scan input
2	I PLAY	I	Input detect I PLAY SW
3	I CrO ₂	I	DECK I Tape Bias selecting input H:70 μ s, L:120 μ s
4	I PACK	I	DECK I Pack switching input H:PACK OFF, L:PACK ON
5	AVss	I	Analog GND
6	TEST	I	GND
7	X2	O	Sub clock
8	X1	I	Sub clock
9	Vss	I	GND
10	OSC1	I	System clock
11	OSC2	O	System clock
12	RES	I	Reset
13	MD0	I	Mode pin:Vcc
14	I PLUNGER	O	Plunger ON/OFF Control output
15	II PLUNGER	O	Plunger ON/OFF Control output
16	VFD RESET	O	VFD RESET Control output
17	I SPEED	O	I Motor speed switching output
18	II SPEED	O	II Motor speed switching output
19	I MOTOR ON	O	I Motor control
20	II MOTOR ON	O	II Motor control
21	4094 CE1	I	Serial Data input
22	4094 CLK	I/O	Serial clock I/O
23	4094 CE2	I	Serial Data input
24	4094 DATA	O	Serial Data out
25	I PLAY	I	Input detect II PLAY SW
26	I CrO ₂	I	DECK II Tape Bias selecting input H:70 μ s, L:120 μ s
27	I PACK	I	DECK II Pack switching input H:PACK OFF, L:PACK ON
28	FWD REC SW	I	DECK II Reverse REC switching input L:REC ON
29	RVS REC SW	I	DECK II Forward REC switching input L:REC ON
30	Vss	I	GND
31	NC		
32	NC		
33	NC		
34	Vcc	I	POWER Supply (+5V)
35	I REEL	I	I Reel pulse input
36	II REEL	I	II Reel pulse input
37	IPSS	I	Input detect IPSS
38	A	O	Function switching output
39	B	O	Function switching output
40	P ON/OFF	O	LED Power switching output

Pin No.	Port Name	I/O	Description
41	◀◀	O	◀◀ LED Control output
42	◀	O	◀ LED Control output
43	F/DOWN	O	F LED Control output
44	■	O	■ LED Control output
45	SET	O	SET LED Control output
46	F/UP	O	F LED Control output
47	▶	O	▶ LED Control output
48		O	LED Control output
49	CH	O	CH LED Control output
50	▶▶	O	▶▶ LED Control output
51	TUNER	O	TUNER LED Control output
52	CD	O	CD LED Control output
53	AUX	O	AUX LED Control output
54	TAPE1	O	TAPE1 LED Control output
55	TAPE2 RED	O	TAPE2 RED LED Control output
56	TAPE2 GRN	O	TAPE2 GRN LED Control output
57	POWER LED	O	POWER LED Control output
58	VR UP	O	Main VR Control output
59	VR DOWN	O	Main VR Control output
60	SUP ON/OFF	O	SUPER BASS Control output
61	TUN MUTE	O	TUNER MUTE Control output
62	PRE MUTE	O	PRE MUTE Control output
63	POW MUTE	O	AMP MUTE Control output
64	POW ON/OFF	O	POWER ON/OFF Control output
65	FLT CE	O	FLT Control output
66	FLT CLK	O	FLT Control output
67	FLT DATA	O	FLT Control output
68	ECHO CE	O	ECHO LEVEL Control output
69	ECHO CLK	O	ECHO LEVEL
70	ECHO DATA	O	ECHO LEVEL
71	E, VR CE	O	E, VR Control output
72	PLL CE	O	PLL Control output
73	E, VR/PLL CLK	O	E, VR/PLL Control output
74	E, VR/PLL D	O	E, VR/PLL Control output
75	PLL DATA OUT	O	PLL Control output
76	XLT	O	Latch signal output
77	CD CLK	O	Clock signal output
78	CD DATA	O	Command data output for CD
79	Vcc .	I	POWER Supply (+5V)
80	IN SW	I	Input to detect sled Inner switch

Pin No.	Port Name	I/O	Description
81	OPEN SW	I	Input to detect tray open position
82	CLOSE SW	I	Input to detect tray close position
83	RX IN	I	REMOCON Signal detection input
84	GFS	I	Input to detect PLL lock condition
85	SCOR	I	Sub Code Q data detection input
86	SENSE	I	Auto sequence end detection input
87	FOK	I	Focus lock detection input
88	SQCK	O	Reading clock output of subcode Q data
89	SUBQ	I	Input to detect Subcode Q data
90	NC		
91	POW DOWN	I	+5V
92	AVcc	I	Analog Power Supply(+5V)
93	63Hz	I	(63Hz, 250Hz, 1KHz, 4KHz, 16KHz) Band frequency level input
94	250Hz	I	(63Hz, 250Hz, 1KHz, 4KHz, 16KHz) Band frequency level input
95	1KHz	I	(63Hz, 250Hz, 1KHz, 4KHz, 16KHz) Band frequency level input
96	4KHz	I	(63Hz, 250Hz, 1KHz, 4KHz, 16KHz) Band frequency level input
97	16KHz	I	(63Hz, 250Hz, 1KHz, 4KHz, 16KHz) Band frequency level input
98	KIN1	I	Key scan input 1
99	KIN2	I	Key scan input 2
100	KIN3	I	Key scan input 3

IC1002 TCM9503-009 (VFD driver/controller μ -COM)

Pin No.	Port Name	I/O	Description
1	Vcc		
2	Vcc		
3	Vcc		
4	Vcc		
5	AVss	I	Analog GND
6	TEST	I	GND
7	X2	O	NC
8	X1	I	Vcc
9	Vss	I	GND
10	OSC1	I	System clock
11	OSC2	O	System clock
12	RES	I	Reset
13	CE	I	VFD Control input
14	Vcc		
15	Vcc		
16	Vcc		
17	Vcc		
18	Vcc		
19	Vcc		
20	S1	O	VFD Segment output
21	S2	O	VFD Segment output
22	S3	O	VFD Segment output
23	S4	O	VFD Segment output
24	S5	O	VFD Segment output
25	S6	O	VFD Segment output
26	S7	O	VFD Segment output
27	S8	O	VFD Segment output
28	S9	O	VFD Segment output
29	S10	O	VFD Segment output
30	S11	O	VFD Segment output
31	S12	O	VFD Segment output
32	S13	O	VFD Segment output
33	S14	O	VFD Segment output
34	S15	O	VFD Segment output
35	S16	O	VFD Segment output
36	S17	O	VFD Segment output
37	S18	O	VFD Segment output
38	S19	O	VFD Segment output
39	S20	O	VFD Segment output
40	Vdisp	I	VFD Power source(233V)

Pin No.	Port Name	I/O	Description
41	NC		
42	NC		
43	G1	O	VFD digit output
44	G2	O	VFD digit output
45	G3	O	VFD digit output
46	G4	O	VFD digit output
47	G5	O	VFD digit output
48	G6	O	VFD digit output
49	G7	O	VFD digit output
50	G8	O	VFD digit output
51	G9	O	VFD digit output
52	G10	O	VFD digit output
53	G11	O	VFD digit output
54	G12	O	VFD digit output
55	G13	O	VFD digit output
56	G14	O	VFD digit output
57	Vcc		
58	Vcc		
59	Vcc		
60	Vcc		
61	Vcc		
62	Vcc		
63	Vcc		
64	Vcc		
65	Vcc		
66	Vcc		
67	Vcc		
68	Vcc		
69	Vcc		
70	VFD CLK	I/O	VFD Serial clock I/O
71	VFD DATA		VFD Control out
72	Vcc		
73	Vcc		
74	Vcc		
75	Vcc		
76	Vcc		
77	Vcc		
78	Vcc		
79	Vcc		
80	Vcc		

IC601 KA9220B (RF + 1SSP FOR CDP)

Pin No.	Port Name	Description
1	AVEE(R)	Analog negative power supply input pin for RF part
2	CPH	Capacitor connection pin of mirror hold.
3	CBH	Capacitor connection pin of defect bottom-hold
4	NC	
5	NC	
6	NC	
7	PFSET	Peak frequency setting pin for focus, tracking compensation and f_c (cut off frequency) of CLV LPF.
8	SSTOP	Check the position pin of pick-up whether inside or not.
9	NC	
10	AVCC(S)	Analog positive power supply input pin for SERVO part.
11	WDCH	Auto-sequencer clock-input pin (Normal speed = 88.2KHz, Double speed = 176.4KHz)
12	SMPD	Connection pin of DSP SMPD
13	SMON	Connection pin of DSP SMON, spindle servo ON at "H"
14	NC	
15	TGSW	Providing time constant to change the high frequency tracking gain
16	RTG	Capacitor connection pin to switch the tracking gain of high frequency
17	LFR	Capacitor connection pin to perform rising low bandwidth of focus servo loop
18	FSW	High frequency gain of focus servo loop can be changed by FS3 switch ON or OFF
19	HFGD	Reducing high frequency gain with capacitor connected between pin 18 and pin 19.
20	FSCH	Time constant external pin to generate focus search waveform
21	VREGI	External regulator voltage input pin for VCO
22	ISET	Determining the peak value of focus search, track jump and SLED kick
23	VREG	3.5V Regulator output pin
24	NC	
25	SMEF	Providing an external LPF time constant of CLV SERVO Loop
26	NC	
27	MCK	Clock input pin from micom
28	MLT	Latch input pin from micom
29	MDAT	Data input pin from micom
30	RESET	Reset input pin from micom, reset at "L"
31	LOCK	Pin for operation of the sled runaway prevention function at "L"
32	TRCNT	Track count output pin
33	ISTAT	Internal status output pin
34	AVEE(S)	Analog negative power supply input pin for SERVO part
35	NC	
36	NC	
37	AASC	Auto-Asymmetry control input pin
38	EFMO	EFM comparator output pin
39	SLEN	Non-inverting input pin of SLED SERVO amplifier

Pin No.	Port Name	Description
40	SLEO	Output pin of SLED SERVO amplifier
41	SLEI	Inverting input pin of SLED SERVO amplifier
42	TEST2	Test input pin to change speed mode Normal speed = "H", Double speed = "L"
43	SPDI	Inverting input pin of spindle servo amplifier
44	SPDLO	Spindle servo amplifier output pin
45	FCE	Inverting input pin of focus servo complifier.
46	FSEO	Output pin of focus servo amplifier
47	TKEI	Non-inverting input pin of tracking servo amplifier
48	TKEO	Output pin of tracking servo amplifier
49	NC	
50	ATS	Anti-shock input pin
51	TZC	Tracking Zero Crossing input pin
52	TE2	Tracking Error Servo input pin
53	TE1	Output pin of tracking Error Amplifier
54	TDFCT	Capacitor Connection pin for Defect Compensation of tracking servo
55	DVCC(S)	Digital positive power supply input pin for servo part
56	FE2	Focus error servo input pin
57	FE1	Output pin of focus error Amplifier
58	FDFCT	Capacitor connection pin for defect compensation of focus servo
59	FOK	Output pin of Focus ok comparator.
60	LDON	Laser diode ON/OFF control pin
61	EI	Feedback input pin of E I-V amplifier
62	EO	Output pin of E I-V Amplifier
63	FBIAS	Bias pin of non-inverting input of focus error amplifier
64	DVEE(S)	Digital negative power supply input pin for servo part
65	RFI	Output Signal of RF summing amplifier is inputed through capacitor
66	RFO	Output pin of RF summing amplifier
67	RF-	Inverting input pin of RF summing amplifier
68	RV	Output pin of $(AVCC + AVEE)/2$ Voltage
69	CV	Bias input pin of Center Voltage buffer
70	LD	Output pin of APC amplifier
71	PD	Input pin of APC amplifier
72	AVCC(R)	Analog positive power supply input pin for RF part
73	NC	
74	PD2	Inverting input pin of RF-I-V AMP2
75	PD1	Inverting input pin of RF-I-V AMP1
76	F	Inverting input pin of F I-V AMP
77	E	Inverting input pin of E I-V AMP
78	NC	
79	DCC2	Defect bottom-hold output is inputed through capacitor
80	DCC1	Output pin of defect bottom-hold

IC602 KS9282B (DSP + 1DAC(16BIT) FOR CDP)

Pin No.	Port Name	I/O	Description
1	AVDD1		Analog Vcc1
2	DPDO	O	Charge pump output for master PLL
3	DPFIN	I	Filter input for master PLL
4	DPFOUT	O	Filter output master PLL
5	CNTVOL	I	VCO control voltage for master PLL
6	AVSS1		Analog Ground 1
7	NC		
8	XIN	I	X-tal oscillator input
9	XOUT	O	X-tal oscillator output
10	WDCH	O	Word clock of 48 bit/SLOT(Normal speed=88.2KHz, Double speed=176.4KHz)
11	NC		
12	NC		
13	DVSS1		Digital Ground 1
14	NC		
15	NC		
16	NC		
17	VREFL1	I	Input terminal 1 of reference voltage "L" (GND Connection)
18	AVDD2		Analog VCC2
19	RCHOUT	O	Right-Channel audio output through D/A Converter
20	LCHOUT	O	Left-Channel audio output through D/A Converter
21	AVSS2		Analog Ground2
22	VREFH1	I	Input terminal 1 of reference voltage "H" (Vdd connection)
23	NC		
24	NC		
25	LKFS	O	The Lock Status output of frame sync
26	SOS1	O	Output of subcode sync signal(S0 + S1)
27	RESET	I	System reset at "L"
28	SQEN	I	SQCK I/O Control("L":internal CK, "H":external CK)
29	SQCK	I/O	Clock for output Subcode-Q data
30	SQDT	O	Serial output of Subcode-Q data
31	NC		
32	SBCK	I	CLOCK for output subcode-Q data
33	SDAT	O	Subcode serial data output
34	DVcc1		Digital Vcc1
35	MUTE	I	Mute control Input("H":Mute ON)
36	MLT	I	Latch Signal Input from Micom
37	MDAT	I	Serial data Input from Micom
38	MCK	I	Serial Clock Input from Micom
39	DB8	O	GND
40	DB7	O	GND

Pin No.	Port Name	I/O	Description
41	DB6	O	GND
42	DB5	O	GND
43	DB4	O	GND
44	DB3	O	GND
45	DB2	O	GND
46	DB1	O	GND
47	NC		
48	NC		
49	NC		
50	NC		
51	NC		
52	NC		
53	DVss2		Digital Ground 2
54	NC		
55	NC		
56	NC		
57	NC		
58	NC		
59	NC		
60	NC		
61	SEL1	I	GND
62	SEL2	I	GND
63	SEL3	I	GND
64	SEL4	I	GND
65	TEST	I	Test Terminal(L = Normal operating state) GND
66	EFMI	I	EFM Signal input
67	NC		
68	ISTAT	O	The internal status output
69	TRCNT	I	Tracking counter input signal
70	LOCK	O	Output signal of LKFS Condition sampled PBFR/16(If LKFS is "H", Lock is "H", If the LKFS is sampled "L" at least 8 times by PBFR/16, Lock is : "L")
71	PBFR	O	Write frame clock (Lock: 7.35KHz)
72	SMEF	O	LPF time constant control of the spindle servo error signal
73	SMON	O	ON/OFF control signal for spindle servo
74	DVcc2		Digital Vcc2
75	SMPD	O	Spindle Motor drive(Rough control in the CLV-S mode Phase control in the CLV-P mode)
76	SMSD	O	Spindle Motor drive(Velocity control in the CLV-P mode)
77	NC		
78	NC		
79	DSPEED	I	Double speed mode control(H:Normal Speed, L:Double Speed)
80	NC		

ABBREVIATIONS

AMPLIFIER

ABBREVIATION	EXPLANATION
A	Analog
AC	Alternating Current
AMP	AMPlifier
CD	Compact Disc
COM	COMMon
D	Digital
D/A	Digital to Analog
DAC	Digital to Analog Converter
DAT	Digital Audio Tape recorder
DC	Direct Current
GND	GrouND
L	Left
LED	Light Emitting Diode
MC	Moving Coil
MM	Moving Magnet
PCB	Printed Circuit Board
R	Right
REG	REGulator
REC	RECord
TR	TRansistor
SW	SWitch
V.AMP	Voltage AMPlifier
V.DISC	Video DISC
VR	Variable Resistance
VTR	Video Tape Recorder

TUNER

ABBREVIATION	EXPLANATION	ABBREVIATION	EXPLANATION
AFC	Auto Frequency Control	MEMO	MEMOry
AGC	Auto Gain Control	MI-COM	MICro-COMputer
ALC	Auto Level Control	MIN	MINimum
AM	Amplitude Modulation	MIX	MIXing
AMP	AMPlifier	MPX	MultipleX
ANT	ANTenna	MW	Medium Wave(frequency)
BATT	BATTery	NC	No Connection
BLK	BLock	NFB	Negative Feed Back
BUFF	BUFFer	OSC	OSCillator
COMP	COMParator	PCB	Printed Circuit Board
DET	DETECT(DETECTOR)	PLL	Phase Locked Loop
FLD	FLUorescent Display	Q.D	Quadrature Detector
FM	Frequency Modulation	Rch	Right channel
FREQ	FREQUENCY	REF	REFerence
GND	GrouND	REG	REGulator
H	High	RF	Radio Frequency
HPF	High Pass Filter	SEG	SEGment
IF	Intermediate Frequency	SELE	SELEctor
IHF	Institut of High Fidelity	SENS	SENSitivity
IND	INDicator	SIG	SIGnal
I/O	In/Out	S/N	Signal to Noise Ratio
JW	Jumper Wire	SSG	Standard Signal Generator
L	Low	STD	STanDard
LCD	Liquid Crystal Display	SW	SWitch : Short Wave(frequency)
Lch	Left channel	THD	Total Harmonic Distortion
LED	Light Emitting Diode	TP	Test Point
LPF	Low Pass Filter	VCO	Voltage Controlled Oscillator
LW	Long Wave(Frequency)	VR	Variable Resistor
		X'TAL	Crystal

COMPACT DISC

ABBREVIATION	EXPLANATION	ABBREVIATION	EXPLANATION
A-D	Analog to Digital (Converter)	Mb	Mega Bits
ADC	Analog to Digital (Converter)	MDA	Motor Drive Amplifier
BCD	Binary Code Decimal	MFM	Modified Frequency Modulation
BPI	Bits per Inch	MM	Mono-stable Multivibrator
CD	Compact Disc	M ₂ FM	Modified Modified Frequency Modulation
CIRC	Cross Interleaving & Reed Solomon Coding	MOD2	Modulo 2(Addition)
CLV	Constant Linear Velocity	MP	Microprocessor
CP	Clock Pulses	MSB	Most Significant Bit
CRCC	Cyclic Redundancy Check Codes	NA	Numerical Aperture
D Level	Decision Level	NRZ	Non Return to Zero
D-A	Digital to Analog (Converter)	NRZ-1	Non Return to Zero Inverted
DAC	Digital to Analog (Converter)	P	Parity Data
DAD	Digital Audio Disc	PAM	Pulse Amplitude Modulation
DEM	Dynamic Element Matching	PCM	Pulse Code Modulation
DPD	Differential Phase Detection	PD	Phase Detector
DSV	Digital Sum Value	PE	Phase Encode
EFM	Eight to fourteen Modulation	PLL	Phase Locked Loop
EX-OR	Exclusive OR	PNM	Pulse Number Modulation
FCI	Flux Changes per Inch	PPM	Pulse Phase Modulation
FIR	Finite Impulse Response	PWM	Pulse Width Modulation
FP	Front Pulse	Q	Parity Data
FPG	Front Pulse Gate	R, R ₁ , R ₂ , etc	Data for Right Channel
F	Frequency of Sampling	RAM	Random Access Memory
GF	Galois Field	RPG	Rear Pulse Gate
H & V (Parity)	Horizontal & Vertical	SCOOP	Self Coupled Optical Pick-up
IIR	Infinite Impulse Response	S & H	Sample & Hold
KB	Kilo Bits	S/N	Signal to Noise Ratio
L, L ¹ , L ² , etc.	Data for Left Channel	SSG	Standard Signal Generator
LPF	Low Pass Filter	SYSCON	SYSTEM CONTROL
LSB	Least Significant Bit		

CASSETTE

ABBREVIATION	EXPLANATION	ABBREVIATION	EXPLANATION
AC	Alternating Current	MIN	MINute
A/D	Analog/Digital	MML	Maximum Modulation Level
AF	Auto Fader	MOL	Maximum Output Level
AMP	AMPlifier	MPX	Multi Plex
AR	Anti Recording	MQSS	Memory Quick Search System
AT BIAS	Auto Turning BIAS	NFB	Negative Feed Back
ATT	ATTenuator	NORM	NORMAl
BAL	BALance	NR	Noise Reduction
BEF	Band Elimination Filter	OSC	OSCillator (OSCillation)
BSS	Blank Search System	P	Pulse
CAP M	CAPstan Motor	PB	Play Back
CH	CHannel	QMSS	Quick Memory Search System
COMP	COMParator	QR	Quick Reverse
CONT	CONTinuanance	R CH	Right CHannel
CRLP	Computer Recording Level Processing	REC	RECOrd(RECOding)
CS	Chip Select	REV	REVERSE
D/A	Digital/Analog	ROT	ROtation
DC	Direct Current	REW	REWind
DET	DETECTOR	SEC	SECOnd
DISCRI	DISCRIminator	SELE	SELEctor
DUB	DUBbing	SENS	SENSitivity
EQ	EQUALizer	SEPP	Single Ended Push Pull
FF(or F.FWD)	Fast Foward	SIG	SIGnal
FLD	FLuoresent Display	SPECT	SPECTrum
FREQ	FREQUENCY	STD	STANdard
FWD	ForWarD	SW	SWitch
GND	GrouND	SYSCON	SYStem CONtrol
H	High	TP	Test Point
HPF	High Pass Filter	TRIG	TRIGa
IND	INDicator	VCA	Voltage Control Attenuator
IPLS	Instant Program Location System	VOL	VOLUME
L	Low	VOLT	VOLTage
L CH	Left CHannel	VR	Variable Resistor
LED	Ligh Emitting Diode	X'TAL	crystal
MEMO	MEMOry	X1	Normal speed
MICOM	MicroCOMputer	X2	Dubble speed

I. SPECIFICATIONS

Model No: SR-400

Type	3Way Bass Reflex
Component	Woofer : TAU-13W03013 Mid-Range : CT-57F12T Piezo Tweeter : PT-20T
Rated Power Input	20W
Maximum Power Input	40W
Rated Impedance	6 Ohm
Dimension	173(W) × 280(H) × 230(D)mm
Weight	3Kg/PC

II. SCHEMATIC DIAGRAM

Model No: SR-400

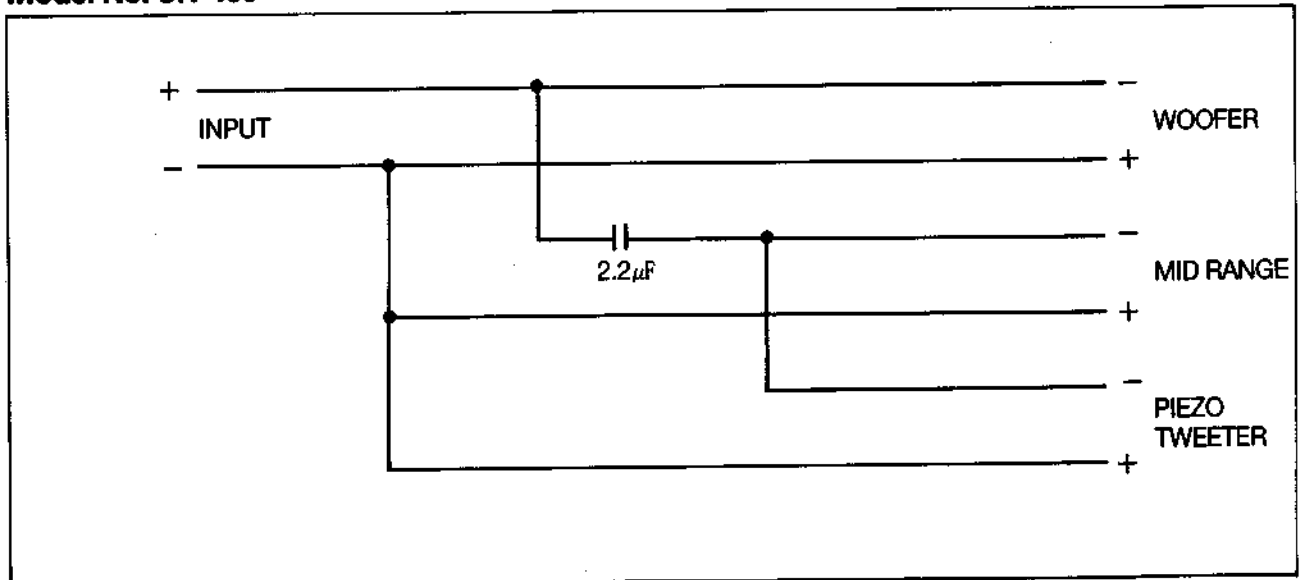

III. PARTS LIST

Model No: SR-400

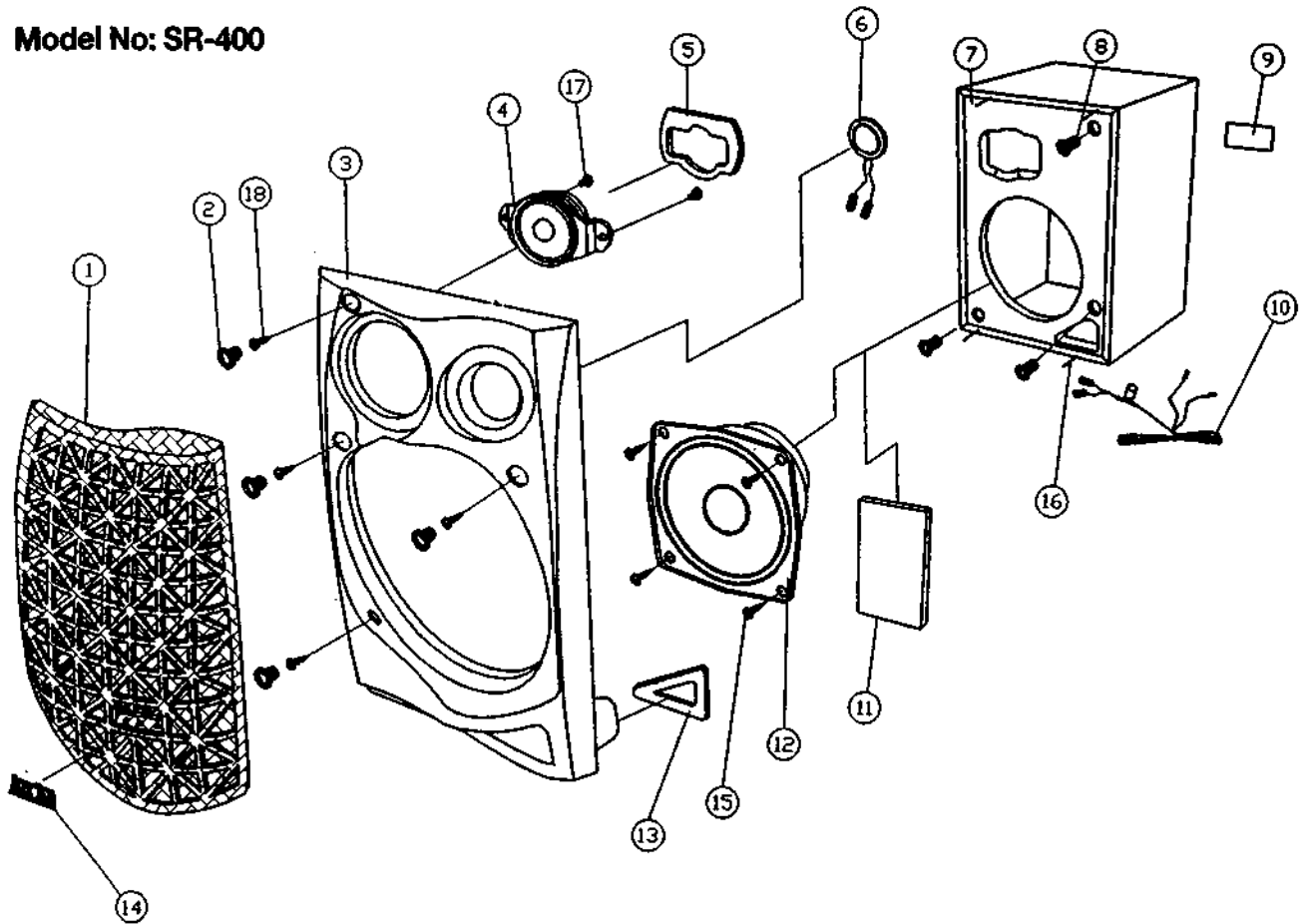

Ref. No	Part No.	Part Name	Description
1(L)	MJSG-00280-001	FRAME NET(L)	
1(R)	MJSG-00290-001	FRAME NET(R)	
2	MMSG-06230-004	HOOK RUBBER	
3(L)	MJSF-00560-ZZ1	COVER FRONT(L)	
3(R)	MJSF-00570-ZZ1	COVER FRONT(R)	
4	SPKT-00820-A70	SP. TWEETER	CT-57F12T
5	MMSG-07230-004	CUSHION MID	
6	SPPZ-00014-A70	SP. PIEZO	PT-20T
8	MJSG-00470-004	HOOK TAPER	
9(L)	YLSP-BG000-01L	BACK LABEL(L)	
9(R)	YLSP-BG000-01R	BACK LABEL(R)	
10	WSD2-24A9A-251	WIRE SP. CORD(D)	D-20/0.12, 2P, 1.9M 2.2 μ F
12	A2UW-F0000-01J	SP. WOOFER	TAU-13W03013
13	MMSG-07240-004	CUSHION DUCT	
14	MJSF-00460-ZZ4	BADGE	
15	XSWB-40150-ZB1	SCREW WOOD	FE-ZB BHT1 4 \times 15
16	MMSC-00320-004	AIR NAIL	D2 \times 20
17	MMSC-00320-004	SCREW COVER	D3 \times D9.5W/W \times 7
18	XSWB-40180-ZY1	SCREW WOOD	FE-ZY BHT1 4 \times 18

(

(

(

(

AKAI