

THOMSON RT 230

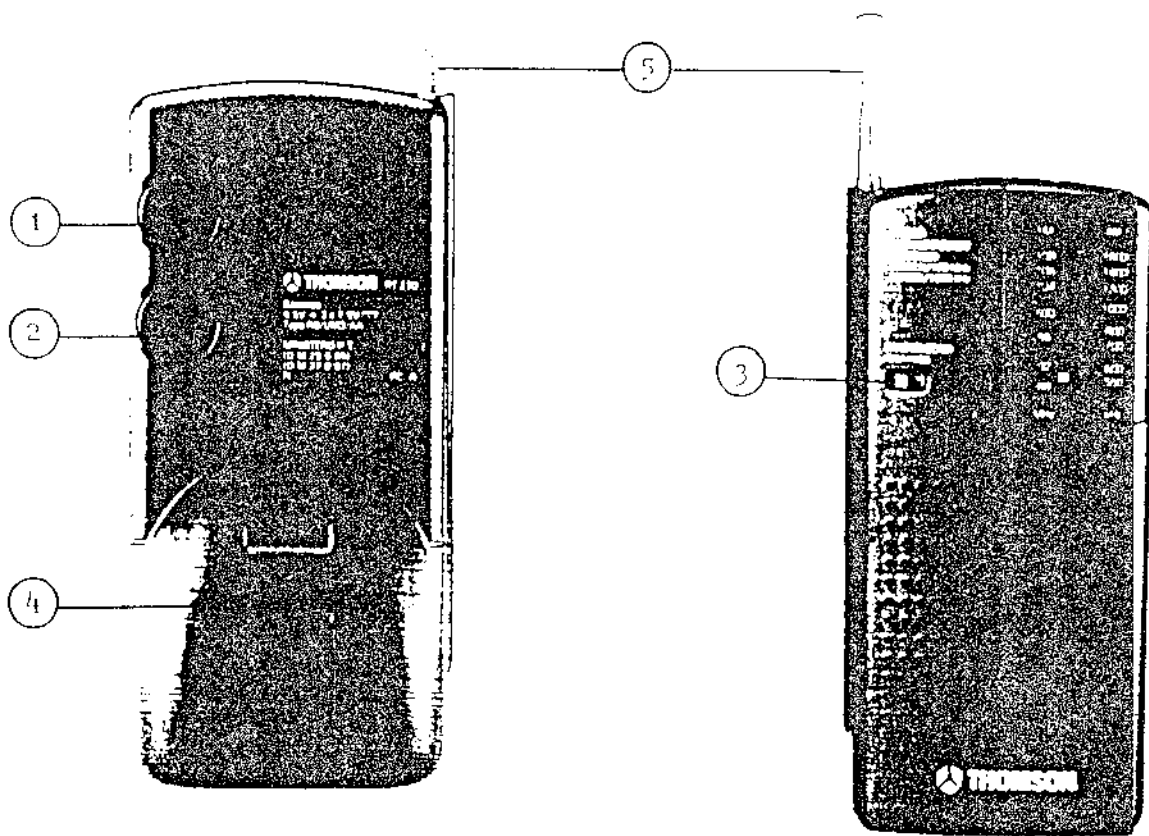
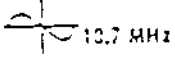

- 1 - On/off volume.
- Manopola per la messa in servizio e l'arresto e di regolazione del volume sonoro.
- 2 - Tuning.
- Manopola di ricerca delle stazioni
- 3 - Band switch.
- Selettore di gamma d'onde.
- 4 - Battery compartment (3 x 1.5V --- R6).
- Coperchio del vano pile (3 x 1.5V --- R6).
- 5 - FM antenna
- Antenna telescopica per la FM.

ALIGNMENT INSTRUCTION
FM SECTION

STEP	ALIGNMENT FREQ.	TEST EQUIPMENT	SIGNAL IN	SIGNAL OUT	ADJUST	REMARK
1	10.7 MHz	(1) FM. IF. SWEEP GENERATOR. (2) ALIGNMENT OSCILLOSCOPE. (3) POWER SUPPLY.	INJECT THE IF. SWEEP SIGNAL THROUGH 10pF CAPACITOR TO (5) POINT.	SIGNAL ARE TAKEN OUT FROM (4) POINT.	REPEAT TO GET "S" CURVE 10.7 MHz 	(1) BAND SW IN FM POSITION. (2) VOL CONTROL IN MIN POSITION. (3) TUNE P.V.C. TO HIGH END.
2	103.5 MHz	(1) FM. RF. SWEEP GENERATOR. (2) ALIGNMENT OSCILLOSCOPE. (3) POWER SUPPLY.	INJECT THE RF. SIGNAL DIRECTLY TO (1) POINT.	SAME AS STEP 1.	ADJUST TC2 GET MAX. OUTPUT	SAME AS STEP 1.
3	87.25 MHz	SAME AS STEP 2.	SAME AS STEP 2.	SAME AS STEP 1.	ADJUST T1 GET MAX. OUTPUT	TUNE P.V.C. TO LOW END
4	REPEAT STEP 2, 3 UNTIL NO FURTHER IMPROVEMENT CAN BE MADE.					
5	106 MHz	SAME AS STEP 2.	SAME AS STEP 2.	SAME AS STEP 1.	ADJUST TC1 GET MAX. OUTPUT	TUNE P.V.C. TO 106 MHz
6	90 MHz	SAME AS STEP 2.	SAME AS STEP 2.	SAME AS STEP 1.	ADJUST L3 GET MAX. OUTPUT	TUNE P.V.C. TO 90 MHz.
7	REPEAT STEP 5, 6 AND THEN STEP 2, 3, 5, 6 UNTIL NO FURTHER IMPROVEMENT CAN BE MADE.					

ALIGNMENT INSTRUCTION
MW SECTION

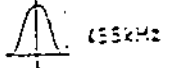
STEP	ALIGNMENT FREQ.	TEST EQUIPMENT	SIGNAL IN	SIGNAL OUT	ADJUST	REMARK
1	455 KHz	(1) AM. IF. SWEEP GEN. WITH LOOP ANTENNA. (2) ALIGNMENT OSCILLOSCOPE. (3) POWER SUPPLY.	LET THE MW ANT. COIL CLOSE TO THE GEN. ANTENNA.	TAKE OUT THE SIGNAL FROM (4) POINT.	ADJUST TC3 TO GET MAX. OUTPUT AT 455kHz. 	(1) BAND SW MW POSITION. (2) VOL CONTROL IN MIN POSITION (3) TUNE P.V.C. TO HIGH END
2	1630 kHz	(1) MW SWEEP GEN. WITH ANT. (2) ALIGNMENT OSCILLOSCOPE. (3) POWER SUPPLY.	SAME AS STEP 1.	SAME AS STEP 1.	ADJUST TC3 GET MAX. OUTPUT AT 1630kHz	SAME AS STEP 1.
3	525.5 kHz	SAME AS STEP 2	SAME AS STEP 1.	SAME AS STEP 1.	ADJUST T1 GET MAX OUTPUT AT 525.5kHz	TUNE P.V.C. TO LOW END.
4	REPEAT STEP 2, 3 UNTIL NO FURTHER IMPROVEMENT CAN BE MADE.					
5	1400 KHz	SAME AS STEP 2	SAME AS STEP 1.	SAME AS STEP 1.	ADJUST TC4 GET MAX OUTPUT AT 1400 KHz.	TUNE P.V.C. TO 1400KHz.
6	600 KHz	SAME AS STEP 2	SAME AS STEP 1.	SAME AS STEP 1.	ADJUST L2 GET MAX. OUTPUT AT 600 KHz.	TUNE P.V.C. TO 600 Hz.
7	REPEAT STEP 5, 6 AND THEN STEP 2, 3, 5, 6 UNTIL NO FURTHER IMPROVEMENT CAN BE MADE.					

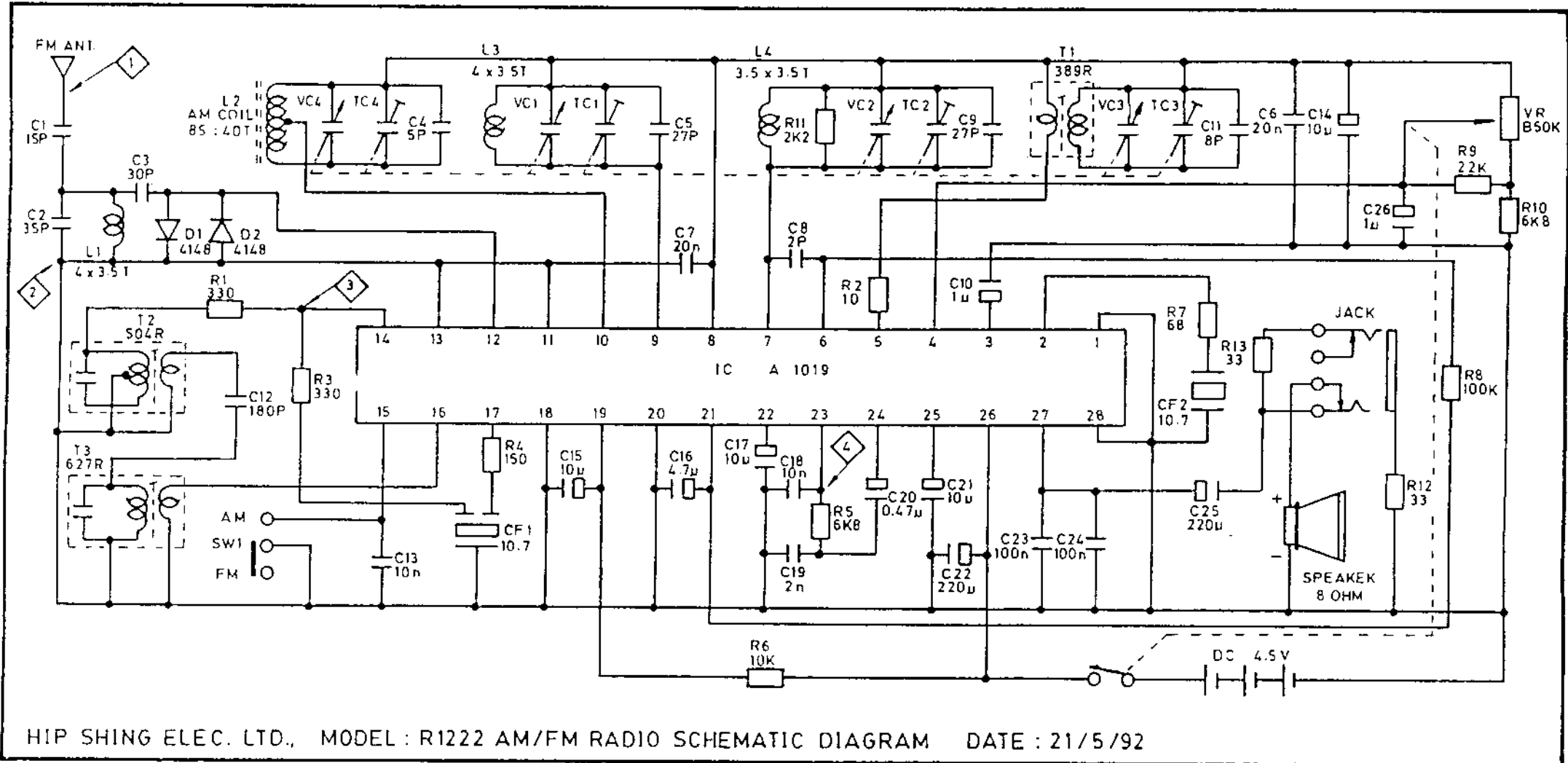

HIP SHING ELEC. LTD., MODEL : R1222 AM/FM RADIO SCHEMATIC DIAGRAM DATE : 21/5/92

MODEL : R1222 AM/FM
BOTTOM VIEW & WIRING DIAGRAM

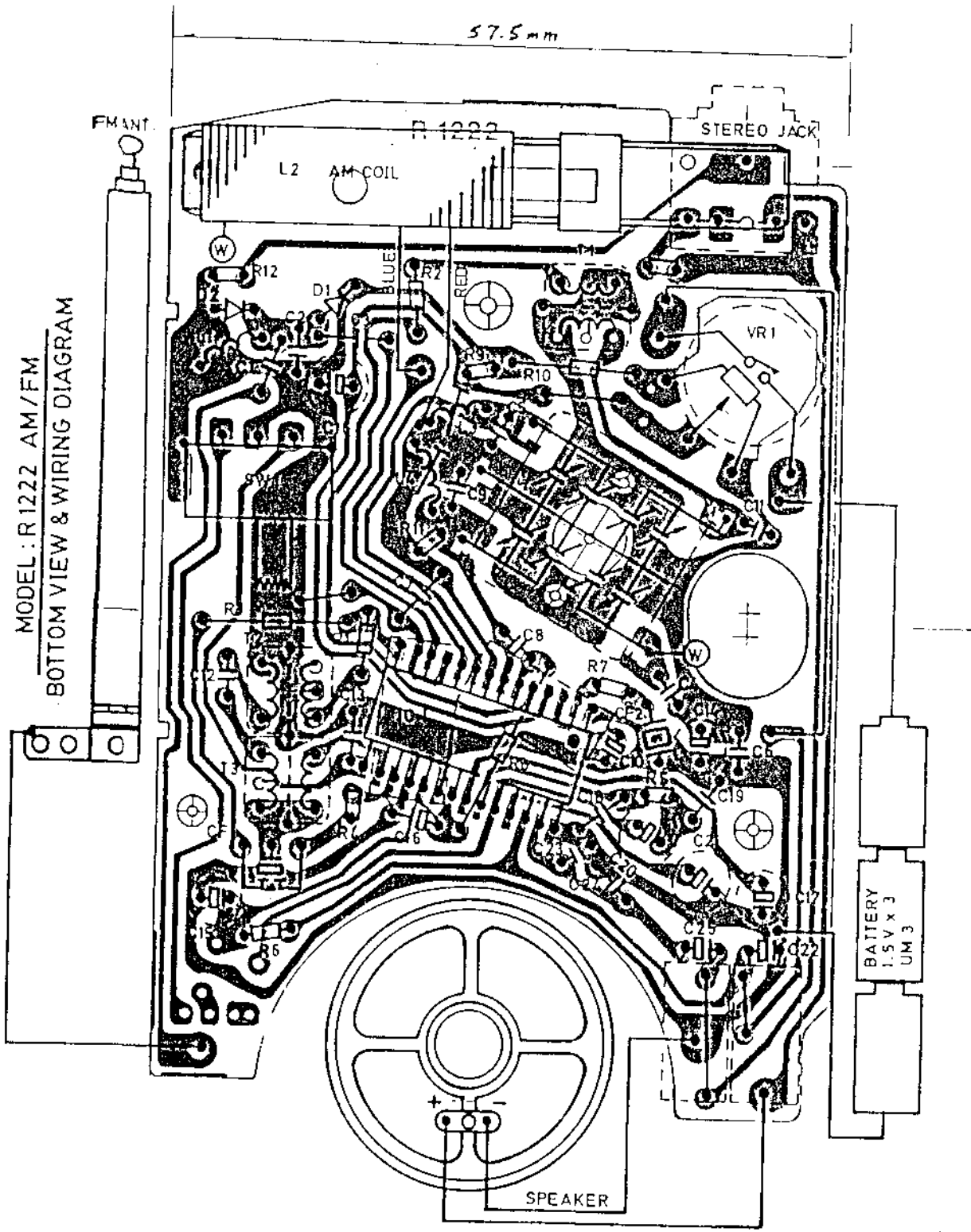

57.5 mm

FM ANT.

R 1222

STEREO JACK

L2 AM COIL

(W)

R12

D1

BLUE

R2

RED

R10

VR1

R3

R7

(W)

C8

(W)

C19

(W)

C21

C22

BATTERY
1.5V x 3
UM 3

SPEAKER