

BF 1081-V

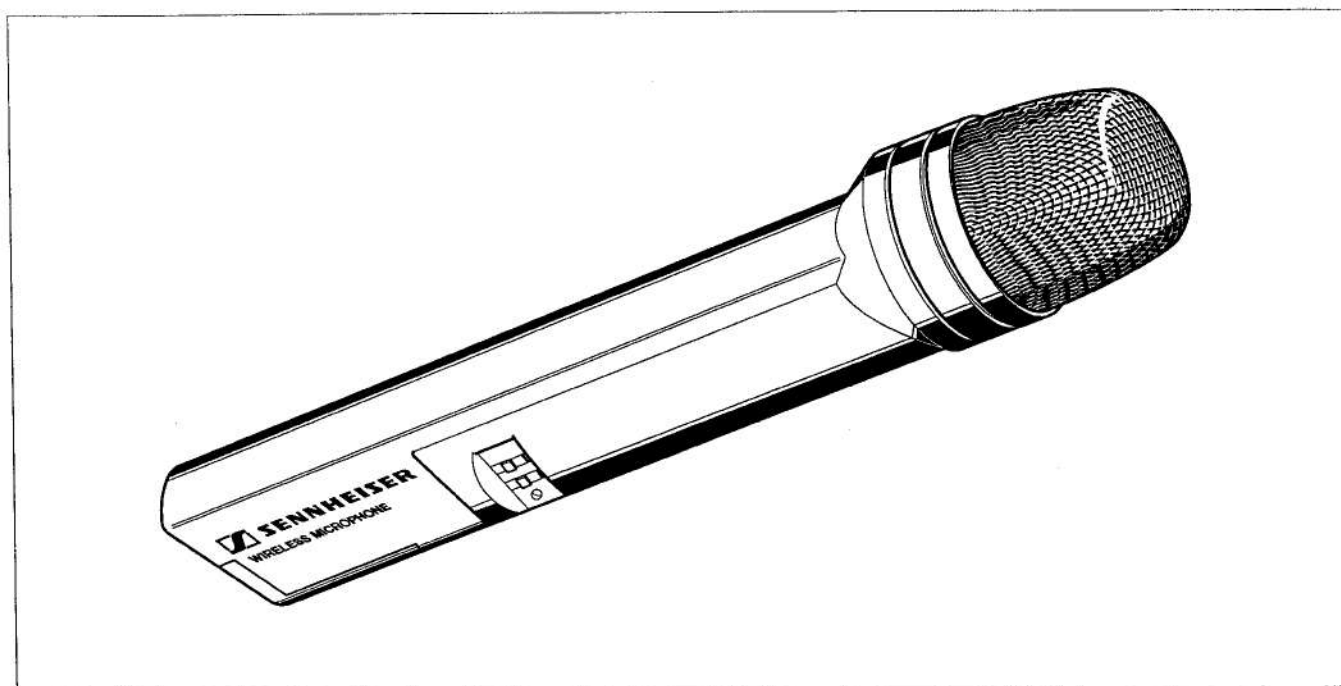

KURZBESCHREIBUNG

Kompakter und schlanker Handsender als drahtloses dynamisches Mikrofon für den harten und störungsfreien Einsatz "on stage". Passend zum Sennheiser-Empfänger EM 1031-V.

MERKMALE

- Extrem rückkopplungsarm durch Supernieren-Richtcharakteristik
- Stoß- und schlagfestes Polyamid-Gehäuse
- bis 8 Stunden ununterbrochener Betrieb mit einer Batterie
- Antenne im Gehäuse integriert
- 6 umschaltbare Sendefrequenzen
- Wirksame Rauschunterdrückung und hohe Dynamik durch HiDynplus.

BRIEF DESCRIPTION

Compact and slim hand-held transmitter for use as a wireless dynamic microphone allowing operation in the most difficult conditions on stage. The BF 1081-V transmitter microphone is to be used in conjunction with the Sennheiser EM 1031-V receiver.

FEATURES

- Excellent feedback rejection thanks to supercardioid pick-up pattern
- Extremely rugged polyamide housing
- Up to 8 hours of continuous operation with one battery
- Antenna integrated into the housing
- Six switchable transmit frequencies
- Excellent dynamic range and noise suppression thanks to HiDynplus

INHALTSVERZEICHNIS		SEITE
1	BEDIENUNGSELEMENTE	3
2	TECHNISCHE DATEN	3
3	ALLGEMEINES	5
3.1	INHALT DER SERVICE-ANLEITUNG	
3.2	SERVICE-KONZEPT	
4	SERVICE HINWEISE	6
4.1	ALLGEMEINES	
4.2	DEMONTAGE	
4.3	FEHLERSUCHE	
5	FEHLERSUCHE	7
5.1	MESSAUFBAU I	
6	MESSGERÄTE UND PRÜFMITTEL	8
7	MESSAUFBAU II	8
8	PRÜF- UND ABGLEICHANLEITUNG	9
9	SCHALTUNTERLAGEN	11
9.1	MIKROFON LEITERPLATTE	11
9.2	BLOCKSCHALTBILD	12
9.3	NF-TEIL, STROMLAUFPLAN	13
9.4	HF-TEIL, STROMLAUFPLAN	14
9.5	VARIABLE BAUELEMENTE	15
9.6	GEDRUCKTE SCHALTUNG, BESTÜCKUNGSSEITE	16
9.7	GEDRUCKTE SCHALTUNG, LÖTSEITE	16
10	EXPLOSIONSZEICHNUNG	17
11	ERSATZTEILE	18

CONTENTS		PAGE
1	OPERATING ELEMENTS	4
2	TECHNICAL DATA	4
3	GENERAL	5
3.1	CONTENTS OF THIS SERVICE MANUAL	
3.2	SERVICE CONCEPT	
4	SERVICE HINTS	6
4.1	GENERAL	
4.2	DISASSEMBLY	
4.3	FAULT ISOLATION	
5	FAULT ISOLATION	7
5.1	TEST SET-UP I	
6	SPECIAL TOOLS AND EQUIPMENT	8
7	TEST SET-UP II	8
8	TEST AND ALIGNMENT PROCEDURE	10
9	SCHEMATICS	11
9.1	MIKROFONE PCB	11
9.2	BLOCK DIAGRAM	12
9.3	AF SECTION, CIRCUIT DIAGRAM	13
9.4	RF SECTION, CIRCUIT DIAGRAM	14
9.5	VARIABLE COMPONENTS	15
9.6	PRINTED CIRCUIT BOARD, COMPONENT SIDE	16
9.7	PRINTED CIRCUIT BOARD, SOLDER SIDE	16
10	EXPLODED VIEW	17
11	SPARE PARTS	18

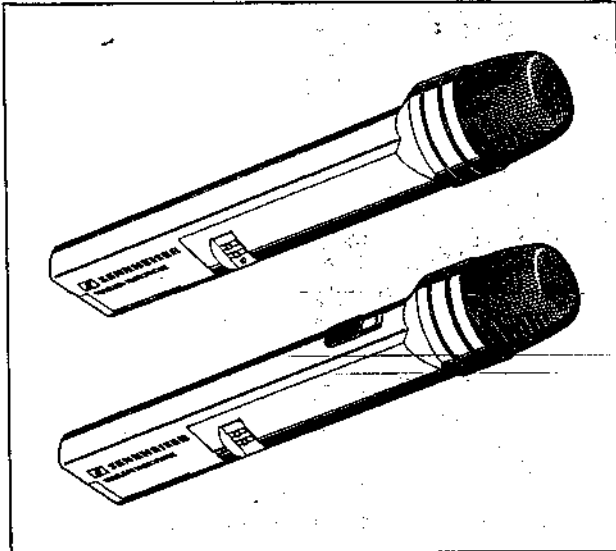

BF 1051-VHF

BF 1081

SKM 1030

SKM 1032

SKM 1072-U

MODIFIKATION DES BATTERIEFACHS

FEHLERERSCHEINUNG:

In einigen Fällen kann es bei o.a. Handsendern bei rauhem "Handling" zu Aussetzern der Spannungsversorgung kommen, wodurch die Übertragung kurzzeitig abreißt. Ursache hierfür kann eine nicht ausreichende Batteriekontaktierung sein, da die mechanischen Abmessungen der 9V-Blockbatterien in Abhängigkeit des Herstellers variieren.

ABHILFE:

Zur verbesserten Fixierung der Batterie werden insgesamt 4 Schaumpolster in das Batteriefach eingeklebt. Für die exakte Montage und Positionierung der Polster ziehen Sie bitte umseitige schematische Darstellung heran.

INHALT:

- Schematische Darstellung des Batteriefachs aller betroffenen Handsender.
- Montageanleitung für die Schaumpolster.

ALLGEMEINES:

Heften Sie diese Service-Information zu den entsprechenden Service-Anleitungen.

MODIFICATION OF BATTERY COMPARTMENT

TROUBLE:

The supply voltage of some hand-held transmitters as listed above may be interrupted intermediately when the transmitters are handled roughly thus causing transmission drop-outs. The problem arising is insufficient battery-contacting due to not-standardized mechanical dimensions of the 9V-batteries depending on manufactures' specifications.

REMEDY:

4 adhesive foam pads are placed in the battery compartment for tighter fitting of the battery. Please refer to the schematic drawing next page for the exact mounting of those pads.

CONTENTS:

- Schematic drawing of battery compartment for all hand-held transmitters affected.
- Mounting instruction for foam pads.

GENERAL:

Please file this service information together with the respective service manuals.

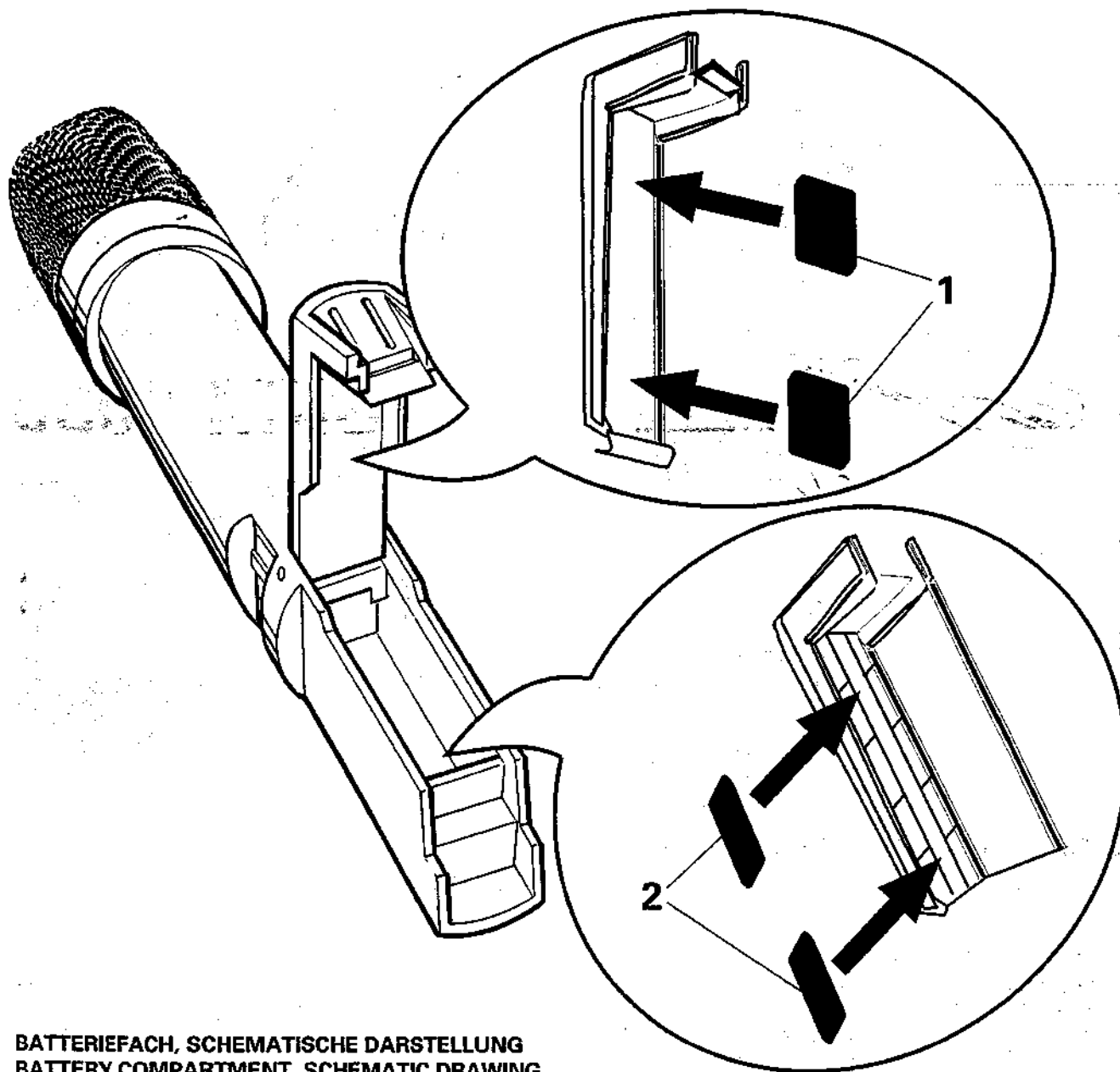

**BATTERIEFACH, SCHEMATISCHE DARSTELLUNG
BATTERY COMPARTMENT, SCHEMATIC DRAWING**

1. Öffnen Sie das Batteriefach und hebeln Sie den Batteriedeckel aus dem Führungsstift.
2. Auf sauberer Oberfläche werden die beiden **großen** Schaumpolster **(1)** wie gezeigt in den Deckel eingeklebt und festgedrückt.
3. Die beiden **kleinen** Schaumpolster **(2)** werden mit einer Pinzette wie gezeigt im Gehäuse positioniert und ebenfalls festgedrückt.
4. Den modifizierten Batteriedeckel vorsichtig wieder auf den Führungsstift drücken.

1. Open battery compartment and lever lid up from pivot.
2. Both **large** foam pads **(1)** are fitted on the clean surface of the lid as shown and pressed to be fixed.
3. The two **small** foam pads **(2)** are placed in the housing with a pair of tweezers as shown and fixed likewise.
4. Press the modified lid cautiously back onto the pivot.

Pos. 1: Schaumpolster, groß (Paar) Ident-Nr.: 74406
Pos. 2: Schaumpolster, klein (Paar) Ident-Nr.: 74407

Pos. 1: Foam pad, large (pair) Id.-No.: 74406
Pos. 2: Foam pad, small (pair) Id.-No.: 74407

1 BEDIENUNGSELEMENTE

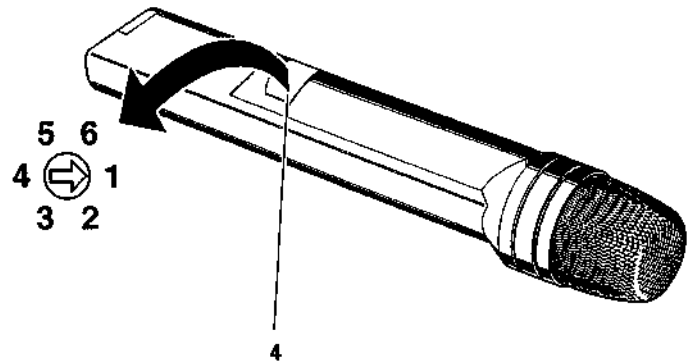
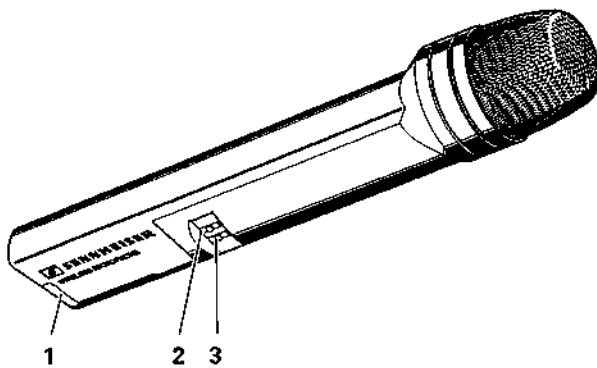

- 1 Batteriefach
- 2 Schaltbare Mikrofonempfindlichkeit
- 3 Ein / Aus - Schalter
- 4 Kanalwahlschalter

2 TECHNISCHE DATEN

HF-TEIL

Frequenzaufbereitung	PLL (Phase-Lock-Loop)-Synthesizer
Trägerfrequenz	132 - 260 MHz
Schaltbandbreite	14 MHz
Kanalzahl	6 Kanäle, umschaltbar
Kanalraster	125 kHz (Vielfache von 5 kHz)
Frequenzstabilität	besser ± 10 kHz (-10 bis +55 °C, UB = 5,5 - 9,5 V)
Sendeleistung	50 mW
Abgestrahlte Leistung	5 mW
Störstrahlungsleistung	< 4 nW
Modulationsart	FM, Breitband
Nennhub bei 1 kHz	± 40 kHz
Spitzenhub	± 56 kHz

NF-TEIL

Schallwandler	dynamisch, Supertiere
Wandlernennimpedanz	350 Ω
Leerlaufübertragungsfaktor	1,2 mV / Pa
Einstellumfang des Empfindlichkeitsschalters	8,5 dB
Trittschallfilter Roll-Off	12 dB / Okt.
High-Cut Roll-Off	24 dB / Okt.
Klirrfaktor	< 2 % bei max. Schalldruck
Preamplifier	50 μ s
Maximaler Schalldruck	153 dB
Geräuschspannungsabstand	120 dBA
Rausch- und Störunterdrückungssystem	HiDynplus

STROMVERSORGUNG, MECHANIK

Batterie	IEC 6 LR 61 9 V, Alkaline (keine NiCd-Akkus verwenden!)
Betriebszeit	bis zu 8 Stunden Dauerbetrieb möglich
Stromaufnahme bei Nennspannung	50 mA
Betriebsspannungsbereich	5,5 - 9 V
Abmessungen in mm	245 x 38
Gewicht	ca. 250 g incl. Batterie

1 OPERATING ELEMENTS

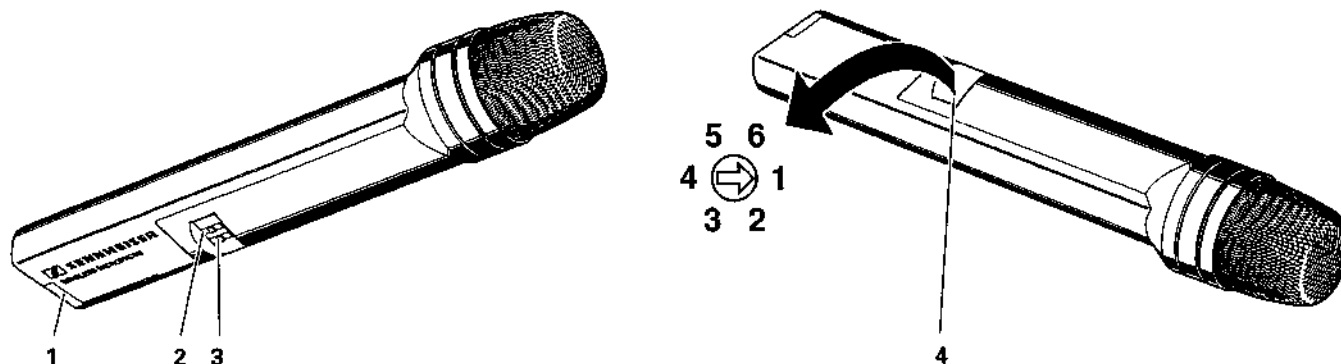

- 1 Batteriefach
- 2 Schaltbare Mikrofonempfindlichkeit
- 3 Ein / Aus - Schalter
- 4 Kanalwahlschalter

2 TECHNICAL DATA

RF SECTION

Frequency generation	PLL (Phase Locked Loop) synthesizer
Carrier frequency	132 - 260 MHz
Switching bandwidth	14 MHz
Channels	6, switchable
Channel grid	125 kHz
Frequency stability	< ±10 kHz (-10 to +55 °C, UB = 5.5 - 9.5 V)
Transmitting output power	50 mW
Radiated power	5 mW
Spurious emissions	< 4 nW
Modulation	FM, wideband
Nominal deviation at 1 kHz	± 40 kHz
Peak deviation	± 56 kHz

AF SECTION

Transducer	dynamisch, supercardioid pick-up pattern
Nominal impedance	350 Ω
Sensitivity (free field, no load)	1.5 mV / Pa
Control range of sensitivity switch	8.5 dB
Roll off filter	12 dB / Oct.
High-Cut Roll-Off	24 dB / Oct.
THD at 1 kHz	< 2% for max. SPL
Preemphasis	50 μs
Max. SPL	153 dB(A)
Signal-to-noise ratio	120 dBA
Compander	HiDynplus

POWER SUPPLY

Battery	IEC 6 LR 61 9 V, alkaline (do not use NiCd batteries!)
Operating time	up to 8 hrs (continuous operation)
Current consumption for rated voltage	50 mA
Operating voltage	5.5 - 9 V
Dimensions in mm	245 x 38
Weight	approx. 250 g incl. battery

3 ALLGEMEINES

3.1 INHALT DER SERVICE-ANLEITUNG

Eine Reparatur kann durch Baugruppentausch vorgenommen werden. Diese Form der Reparatur hat sich in der Praxis bewährt und begrenzt das notwendige Funktionsverständnis auf die Baugruppen.

Auf geeigneten Meßplätzen kann die Reparatur der Moduln bis auf Bauteilebene erfolgen. Detaillierte Reparaturanleitungen befinden sich in den Service-Hinweisen und der Prüf- und Abgleichanleitung.

Die Service-Anleitung vermittelt das entsprechende Wissen zur Fehlerlokalisierung und Reparatur des BF 1081-V.

3.2 SERVICE-KONZEPT

3.2.1 Leiterplatte

Die Leiterplatte des BF 1081-V ist als 2-seitig kupferkaschierte Platine aufgebaut und kann durch einen unsachgemäßen Reparaturversuch irreparabel beschädigt werden.

3.2.2 Service-Anleitung

Die Service-Anleitung soll dem Techniker die Möglichkeit bieten, die wichtigsten Reparatur- und Abgleicharbeiten ausführen zu können.

Die Service-Anleitung kann im Bedarfsfall auch dem Kunden ausgehändigt werden.

3.2.3 SMD (Surface Mounted Devices)

Die Leiterplatten des BF 1081-V sind weitgehend mit Chip-Elementen (SMD) bestückt. Sollte beim Hantieren mit den Baugruppen ein SMD mechanisch zerstört werden, ist es erforderlich, dieses Bauelement zu ersetzen.

SMD werden direkt auf die dafür vorgesehenen Lötflächen gelötet. Hierfür besitzen sie lötfähige Stirnkontaktierungen, die weitgehend hitzeunempfindlich sind.

Zum Auswechseln ist folgendes Werkzeug erforderlich: Neben einer Pinzette und einem normalen temperaturgeregelten LötKolben (z. B. Weller mit 0,8 mm Flachkopflötspitze PT-H 7 oder 0,8 mm Langkopflötspitze PT-K 7) sollten noch ein absolut rückschlagfreies Absauggerät und 1,2 mm Entlötlitze vorhanden sein. Sinnvoll ist eine Arbeitslupe.

Die Lötzeit ist so kurz wie möglich zu halten, damit die Leiterbahnen nicht beschädigt werden. Besonders beim Auslöten der Bauteile ist darauf zu achten, daß die Leiterbahnen nicht abgehoben werden. Danach ist die Auflagefläche der Bauteile von Lötresten zu säubern. Um mechanische Spannungen in den Bauteilen zu vermeiden, sollte man erst nach dem Erkalten der ersten Lötstelle die gegenüberliegende Seite anlöten.

Eine Wiederverwendung eines bereits ausgelöteten Chip-Bauelementes ist nicht zulässig. Dies gilt auch dann, wenn es offensichtlich fehlerfrei ist, da durch die mechanische Beanspruchung beim Ein- und Auslöten eine Beschädigung nicht ausgeschlossen werden kann.

Die SMD werden als Ersatzteile in Packeinheiten von je 50 Stück geliefert. Die Lagerbehälter müssen verwechslungssicher gekennzeichnet sein, da nur dadurch eine Unterscheidung der Bauteile möglich ist.

3 GENERAL

3.1 CONTENTS OF THIS SERVICE MANUAL

Practical experience gained from corrective maintenance shows that it is best to repair the unit by replacing defective modules. This type of repair has proven to be good in practical use as it spares the service engineer the effort to learn all details on the unit's complex circuit design.

Special tools and test equipment allow the modules to be easily repaired up to the lowest level, i.e. their individual components. Detailed instructions are given in the service hints as well as in the test and alignment instructions.

The present service manual shall provide the service engineer with important information required to find faults and to repair the BF 1081-V.

3.2 SERVICE CONCEPT

3.2.1 Printed circuit board

The PCB incorporated into the BF 1081-V is a double-sided printed circuit board which can be accidentally damaged through improper handling or repair.

3.2.2 Service manuals

The present document shall help the service engineer to accomplish the most important maintenance and repair work.

The service manual may be handed to customers, if need be.

3.2.3 SMD (Surface Mounted Devices)

The PCBs incorporated into the BF 1081-V chiefly include Surface Mounted Devices (SMD). Should one SMD be accidentally damaged, replace the defective component with a new one.

SMDs are to be soldered to the surface provided for this purpose. They feature solderable contacts which are relatively insensitive to heat.

Tools required to replace SMDs: tweezers, temperature-controlled soldering iron (e.g. Weller with 0.8 mm flat headed soldering tip PT-H 7 or 0.8 mm oblong soldering tip PT-K 7), blow-back proof unsoldering set, 1.2 mm unsoldering wire. It is recommendable to use magnifying glasses.

Minimize the soldering time in order not to damage the PCB. Be careful not to damage any tracks when unsoldering the components to be replaced. Clean the surface. Wait until the first soldered joint has cooled down before starting to solder the opposite side. This serves to avoid stress built-up in the components.

Do not reuse unsoldered components, even if they seem to be faultless. Mechanical damage, possibly caused by soldering or unsoldering some components, cannot be excluded.

SMDs are available as spare parts, 50 pcs. packaged in a poly bag. Containers or packages should be marked in order to make the components distinguishable from each other.

4 SERVICE HINWEISE

4.1. ALLGEMEINES

Der Handsender BF 1081-V ist in 6 Frequenzbereichen innerhalb des VHF-Bandes erhältlich. Die Varianten (I - VI) unterscheiden sich durch eine geänderte Bestückung (siehe Tabelle auf Seite 15).

- Typ I: 132 - 144 MHz, Schaltbandbreite 12 MHz
- Typ II: 169 - 184 MHz, Schaltbandbreite 14 MHz
- Typ III: 183 - 200 MHz, Schaltbandbreite 16 MHz
- Typ IV: 199 - 217 MHz, Schaltbandbreite 18 MHz
- Typ V: 216 - 235 MHz, Schaltbandbreite 20 MHz
- Typ VI: 234 - 260 MHz, Schaltbandbreite 22 MHz

4.2 DEMONTAGE:

GEHÄUSE

- Einsprachekorb (1) abschrauben.
- Popschutz (2) aus Einsprachekorb (1) entnehmen. Bei Bedarf Popschutz auswaschen oder ersetzen.
- Batteriefach (3) öffnen.
- Batteriekontakte (4) entnehmen.
- Leiterplatte aus Griff (6) schieben; dazu Sicherung (5) der Leiterplatte mit kleinem Schraubendreher entriegeln.

MIKROFON

- Anschlußdrähte von Mikrofonkapsel (7) entlöten.
- Kapsel von Federung schrauben.

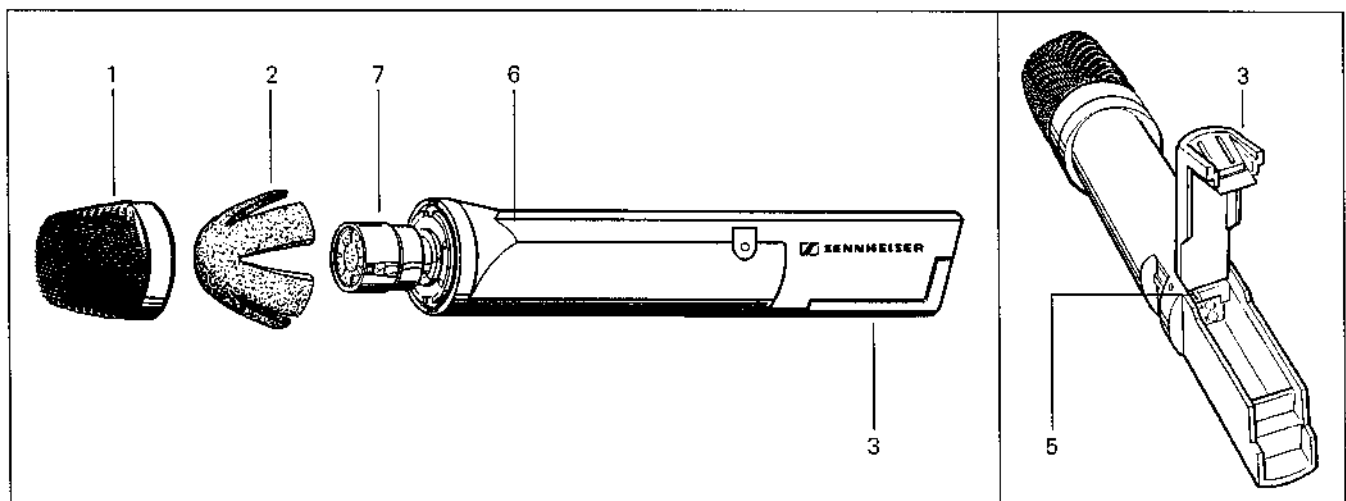

4.3 FEHLERSUCHE

- Handsender BF 1081-V besprechen und mit dem Empfänger EM 1031-V (Kopfhörer) abhören. Funktionsüberprüfung mit anschließendem Abklopfen und Reichweitentest.
- Handsender BF 1081-V demontieren.
- Die Fehlersuche beim BF 1081-V unterteilt sich in:
 - Überprüfen der Testpunkte TP 1 - TP 19 auf der Bestückungsseite der Leiterplatte. Dazu Verfahren wie im Abschnitt "Fehlersuche" auf Seite 7. Bei stark abweichenden Meßwerten Leiterplatte unter Zuhilfenahme des Stromlaufplanes reparieren.
 - Durchführen der "Prüf- und Abgleichanweisung".
- Handsender BF 1081-V montieren.
- Handsender BF 1081-V besprechen und mit dem Empfänger EM 1031-V (Kopfhörer) abhören. Funktionsüberprüfung mit anschließendem Abklopfen und Reichweitentest.

4 SERVICE HINTS

4.1. GENERAL

The hand-held transmitter BF 1081-V is available in six frequency ranges in the VHF band. The types (I - VI) are equipped with variable components (pls. see table on page 15).

- Type I: 132 - 144 MHz, switching bandwidth 12 MHz
- Type II: 169 - 184 MHz, switching bandwidth 14 MHz
- Type III: 183 - 200 MHz, switching bandwidth 16 MHz
- Type IV: 199 - 217 MHz, switching bandwidth 18 MHz
- Type V: 216 - 235 MHz, switching bandwidth 20 MHz
- Type VI: 234 - 260 MHz, switching bandwidth 22 MHz

4.2 DISASSEMBLY:

HOUSING

- Unscrew the sound inlet basket (1).
- Remove the pop shield (2) from the sound inlet basket (1). Clean or replace the pop shield, if need be.
- Open the battery compartment (3).
- Remove the battery contacts (4).
- Slide the PCB out of the handle (6); to that end, disengage the catch (5) on the PCB with a small screwdriver.

MICROPHONE

- Unsolder the leads from the microphone capsule (7).
- Unscrew the capsule from its suspension.

4.3 FAULT ISOLATION

- Speak into the BF 1081-V transmitter microphone and monitor the correct working of the system with the help of the EM 1031-V receiver (headphones). Performance test, incl. subsequent tapping and transmission range tests.
- Disassemble the BF 1081-V transmitter microphone.
- Fault isolation procedures:
 - Check test points TP 1 - TP 19 on the component side of the PCB. Pls. proceed as described in "FAULT ISOLATION" on page 7. For deviating test results, the PCB is to be repaired with the help of the circuit diagram.
 - Follow the "TEST AND ALIGNMENT PROCEDURES".
- Assemble the BF 1081-V transmitter microphone.
- Speak into the BF 1081-V transmitter microphone and monitor the correct working of the system with the help of the EM 1031-V receiver (headphones). Performance test, incl. subsequent tapping and transmission range tests.

5 FEHLERSUCHE

5.1 MESSAUFBAU I

- Mikrofonmodul ablöten.
- NF-Signal (1kHz, 320 mV) an TP 2 einspeisen (TP 1 \perp).
- Betriebsspannung (9 V) an Batteriekontakte anlegen.
- Ein / Aus Schalter S1 in Stellung "ON" bringen.
- Kanalwahlschalter S4 in Stellung "3" bringen.
- Empfindlichkeitseinsteller S3 in Stellung "Lo" bringen.
- Testpunkte mit DC-Voltmeter ($R_i \geq 1 \text{ M}\Omega / \text{V}$) überprüfen.

5 FAULT ISOLATION

5.1 TEST SET-UP I

- Unsolder the microphone module.
- Input the AF (1kHz, 320 mV) via TP 2 (TP 1 \perp).
- Apply the operating voltage (9 V) to the battery contacts.
- Set the ON/OFF switch S1 to "ON".
- Set the channel selector switch S4 to "3".
- Set the sensitivity switch S3 to "Lo".
- Check the test points using the DC voltmeter ($R_i \geq 1 \text{ M}\Omega / \text{V}$).

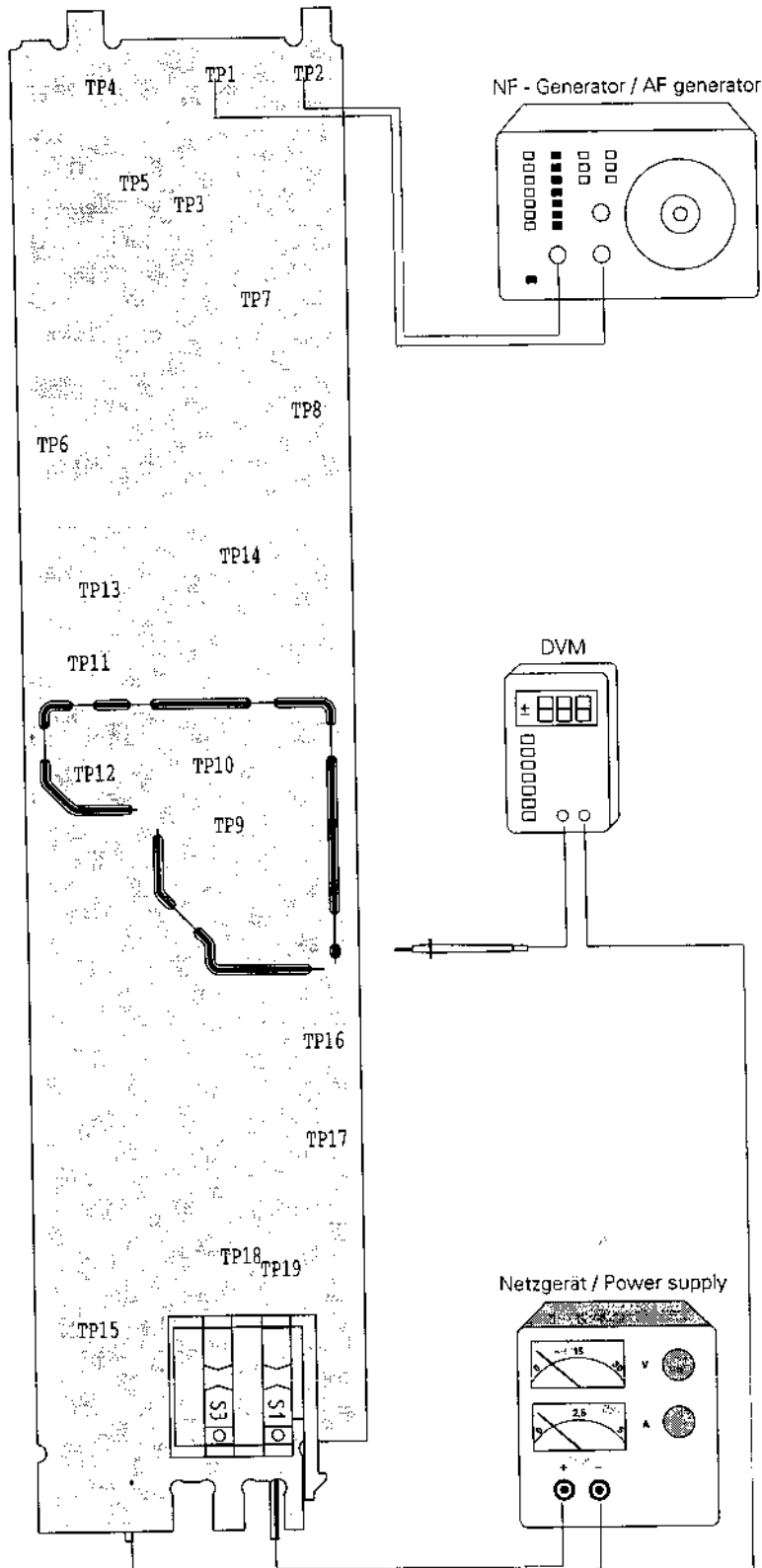

Testpunkt Test point	Sollwert Desired value
TP 1	0.0 VDC
TP 2	0.0 VDC
TP 3	4.1 VDC
TP 4	2.5 VDC
TP 5	2.45 VDC
TP 6	1.0 VDC
TP 7	3.6 VDC
TP 8	0.0 VDC
TP 9	1.9 VDC
TP 10	4.25 VDC
TP 11	4.8 VDC
TP 12	0.6 VDC
TP 13	0.44 VDC
TP 14	0.3 VDC
TP 15	0.0 VDC
TP 16	2.3 ± 0.5 VDC
TP 17	5.0 VDC
TP 18	8.2 VDC
TP 19	0.06 VDC

6 MESSGERÄTE UND PRÜFMITTEL

- 1 Modulationsanalysator (z.B. Rohde & Schwarz FAM)
- 1 NF-Signalgenerator (z.B. Leader LAG 126 S)
- 1 NF-Millivoltmeter (z.B. UPM 550 - 1)
- 1 HF-Millivoltmeter (z.B. Rohde & Schwarz)
- 1 HiDyn Expander II (z.B. Sennheiser Ident.-Nr. 49556)
- 1 Oszilloskop (z.B. Hameg 605)
- 1 Voltmeter $R_i \geq 1 \text{ M}\Omega / \text{V}$ (z. B. Thandar TM 351)
- 1 Amperemeter (z.B. Thandar TM 351)
- 1 Netzgerät 0 - 30 V / 2 A

6 SPECIAL TOOLS AND EQUIPMENT

- 1 Modulation analyzer (e.g. Rohde & Schwarz FAM)
- 1 AF signal generator (e.g. Leader LAG 126 S)
- 1 AF millivoltmeter (e.g. UPM 550 - 1)
- 1 RF millivoltmeter (e.g. Rohde & Schwarz)
- 1 HiDyn expander II (e.g. Sennheiser Ident. No. 49556)
- 1 Oscilloscope (e.g. Hameg 605)
- 1 Voltmeter $R_i \geq 1 \text{ M}\Omega / \text{V}$ (e.g. Thandar TM 351)
- 1 Ammeter (e.g. Thandar TM 351)
- 1 Power supply 0 to 30 V / 2 A

7 MESSAUFBAU II

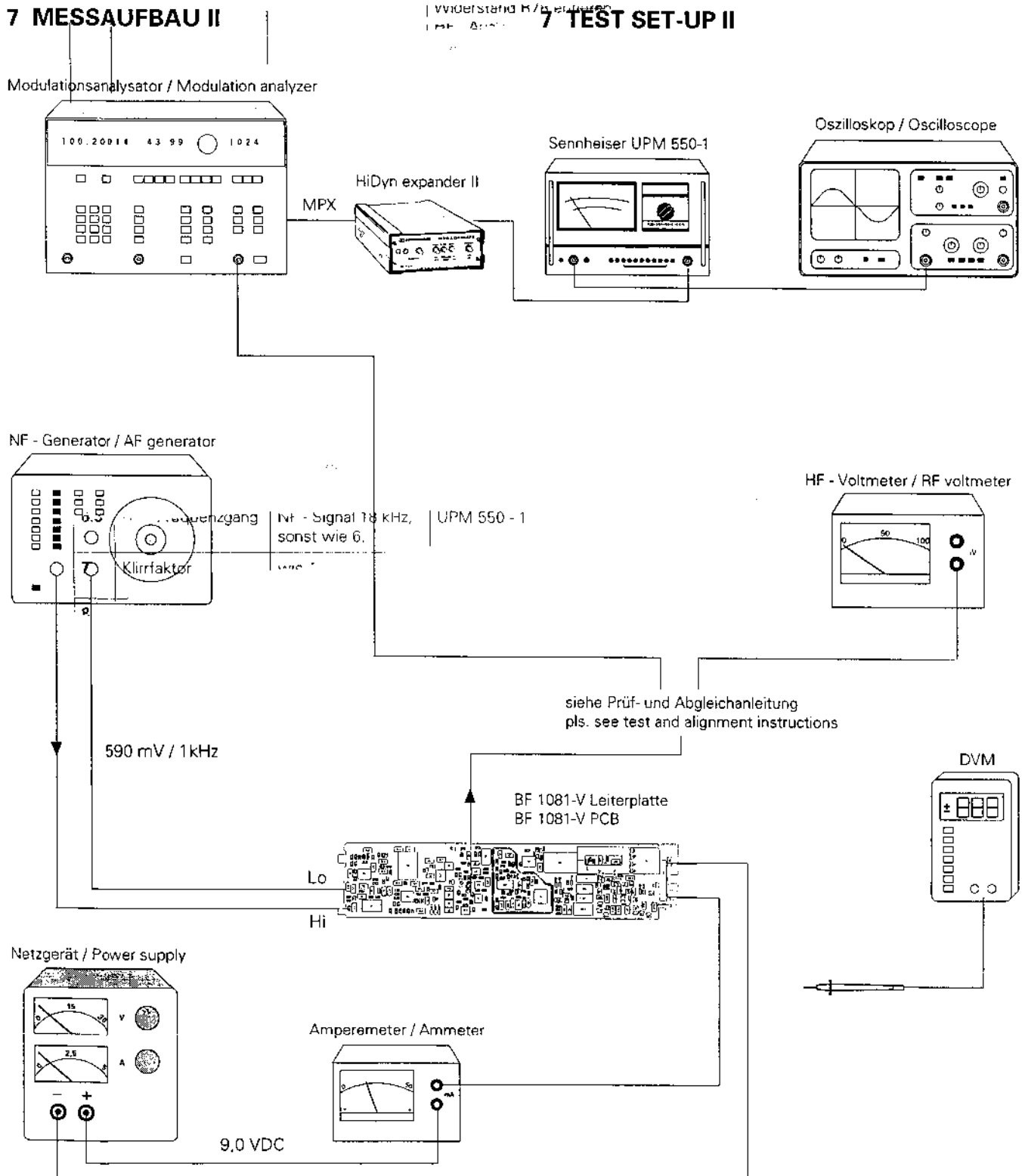

7 TEST SET-UP II

8 PRÜF - UND ABGLEICHANWEISUNG

Nr.	Messung, Einstellung	Signal-einspeisung	Vorbereitung, Geräteeinstellung	Meßpunkt	Sollwert	Einsteller	Bemerkungen
1	Stromaufnahme	NF - Signal (1 kHz, 320 mV) an TP 2 einspeisen (TP 1 ⊥ 1) (siehe Meßaufbau)	Mikrofonmodul ablöten; Batteriespannung (9 V) an Batteriekontakte anlegen; Ein / Aus-Schalter S1 "ON"; Kanalwahlschalter S4 "1"; Empfindlichkeit S3 "Lo"	Ampere-meter	42 - 55 mA		
2	HF - Pegel	wie 1.	Ein / Aus-Schalter S1 "OFF" Widerstand R78 entlöten; HF - Ausgang über C72 messen; Ein / Aus-Schalter S1 "ON"; HF - Voltmeter	U C72	1,2 - 1,6 Veff an 50 Ω		
3	Sendefrequenz Kanal 1	wie 1.	Modulationsanalysator	U C72	f ± 2 kHz		
3.1	Sendefrequenz Kanal 2 - 6	wie 1.	Kanalwahlschalter S4 "2 - 6"; Modulationsanalysator	U C72	f ± 2 kHz		
4	VCO Abstimmspannung	wie 1.	Kanalwahlschalter S4 "1"; DC - Voltmeter	TP 16	2,3 V ± 0,5 V	L6	
5	Nennhub	wie 1.	Modulationsanalysator	U C72	± 40 kHz	R42	
5.1	Spitzenhub	wie 1.	Empfindlichkeit S3 "Hi"; Modulationsanalysator	U C72	± ± 56 kHz		
6	NF - Frequenzgang	NF - Signal 3 mV, sonst wie 1.	Empfindlichkeit S3 "Lo"; UPM 550 - 1 auf 0 dB eichen	U C72			
6.1	NF - Frequenzgang	NF - Signal 80 Hz, sonst wie 6.	UPM 550 - 1	U C72	- 3 dB		
6.2	NF - Frequenzgang	NF - Signal 10 kHz, sonst wie 6.	UPM 550 - 1	U C72	+ 1,5 dB		
6.3	NF - Frequenzgang	NF - Signal 18 kHz, sonst wie 6.	UPM 550 - 1	U C72	0 dB		
7	Klirrfaktor	wie 1.	UPM 550 - 1	U C72	typ. 0,2 %		
8	Endprüfung		Handsender BF 1081-V montieren; dazu R78 einlöten (nur neues Bauteil verwenden), Mikrofonmodul montieren und anlöten. Nach Endmontage Hand-sender betriebsbereit machen und mit Empfänger EM 1031-V Funktion überprüfen				

8 TEST AND ALIGNMENT INSTRUCTIONS

No.	Measurement, adjustment	Signal input	Preparations, settings	Test point	Desired value	Adjuster	Remarks
1	Current consumption	Input the AF (1 kHz, 320 mV) via TP 2 (TP 1 L) (pls. see test set-up)	Unsolder the microphone module; apply the operating voltage (9 V) to the battery contacts; ON/OFF switch S1 "ON"; channel selector switch S4 "1"; sensitivity switch S3 "Lo"	Ammeter	42 - 55 mA		
2	RF level	as 1.	ON/OFF switch S1 "OFF"; unsolder resistor R78; check the RF signal via C72; ON/OFF switch S1 "ON"; RF voltmeter	U C72	1.2 - 1.6 V _{eff} 50 Ω loaded		
3	Transmit frequency channel 1	as 1.	Modulation analyzer	U C72	f ± 2 kHz		
3.1	Transmit frequency channel 2 - 6	as 1.	Channel selector switch S4 "2 - 6"; modulation analyzer	U C72	f ± 2 kHz		
4	VCO tuning voltage	as 1.	Channel selector switch S4 "1"; DC voltmeter	TP 16	2.3 V ± 0.5 V	L6	
5	Nominal deviation	as 1.	Modulation analyzer	U C72	± 40 kHz	R42	
5.1	Peak deviation	as 1.	Sensitivity switch S3 "Hi"; modulation analyzer	U C72	≤ ± 56 kHz		
6	Audio frequency response	Audio signal 3 mV, proceed as described in step 1.	Sensitivity switch S3 "Lo"; calibrate UPM 550 - 1 (0 dB)	U C72			
6.1	Audio frequency response	Audio signal 80 Hz, proceed as described in step 6.	UPM 550 - 1	U C72	- 3 dB		
6.2	Audio frequency response	Audio signal 10 kHz, proceed as described in step 6.	UPM 550 - 1	U C72	+ 1.5 dB		
6.3	Audio frequency response	Audio signal 18 kHz, proceed as described in step 6.	UPM 550 - 1	U C72	0 dB		
7	THD	as 1.	UPM 550 - 1	U C72	typ. 0.2 %		
8	Performance test		Assemble the BF 1081-V; solder in R78 (new component only), mount and solder the microphone module. After the transmitter has been completely assembled, it has to be readied for operation and checked for correct working using a EM 1031-V receiver.				

9 SCHALTUNTERLAGEN
9.1 MIKROFON - LEITERPLATTE

9 SCHEMATICS
9.1 MICROPHONE PCB

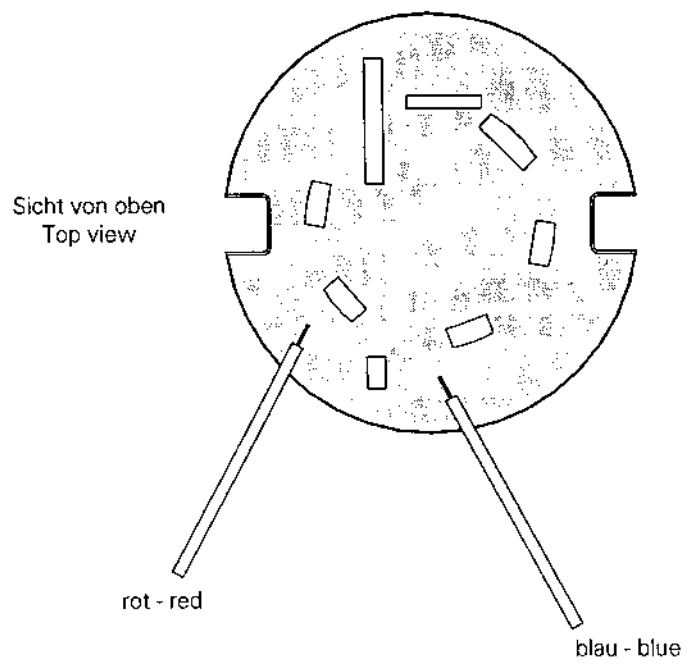
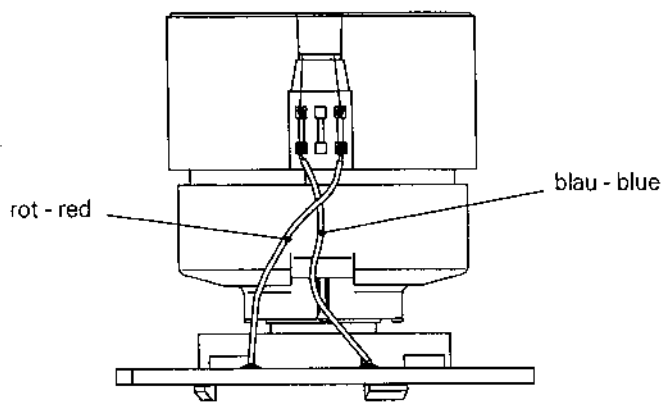

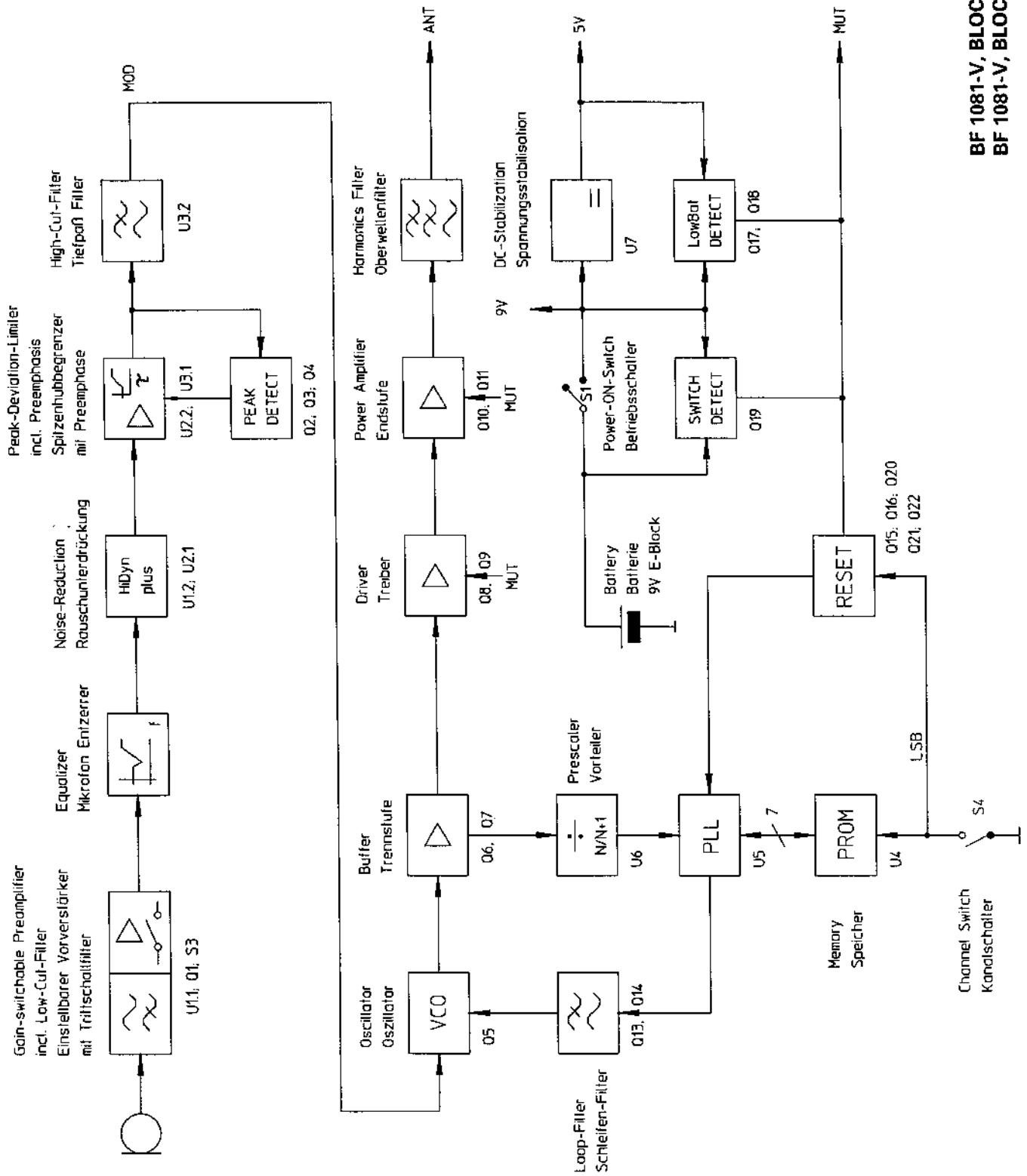

BF 1081-V, BLOCKSCHALTBILD
BF 1081-V, BLOCK DIAGRAM

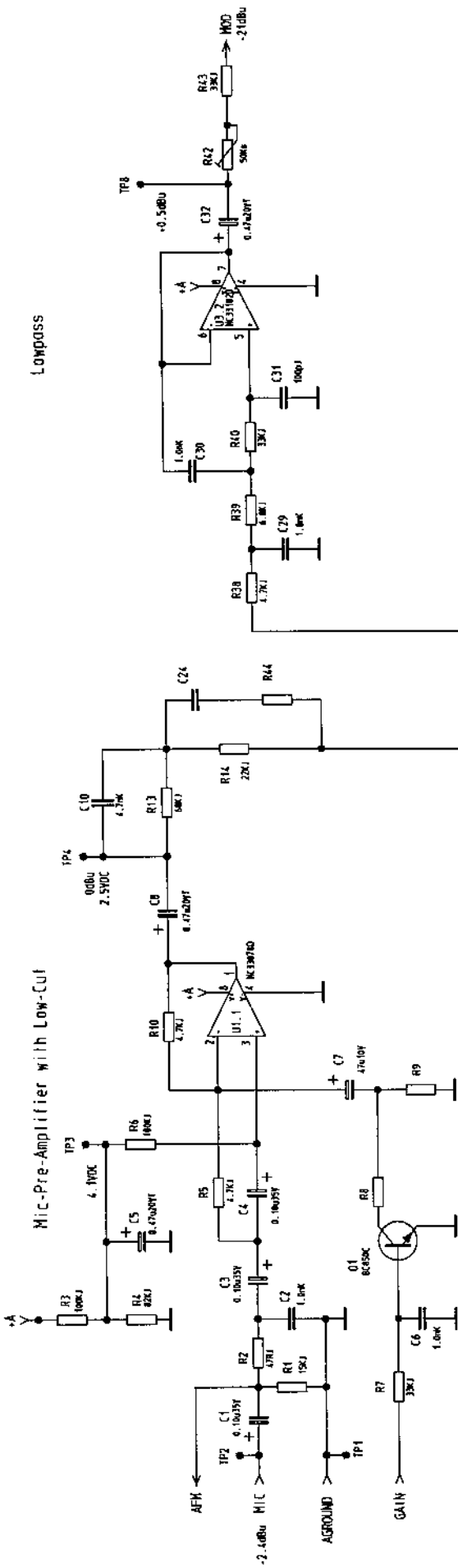

LOWPASS

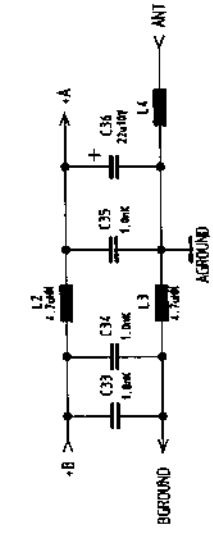
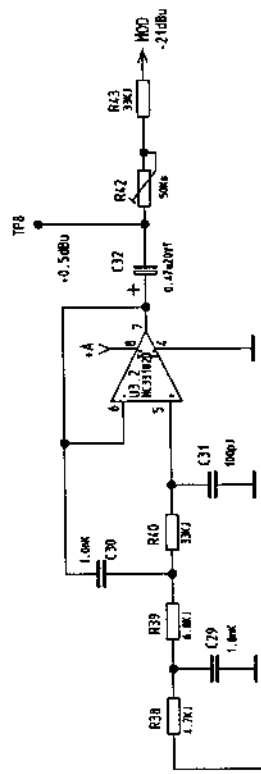

Remark: All audio levels given at 1kHz AF and low sensitivity for nominal deviation of 40kHz!
 (0dBu = 775mV)

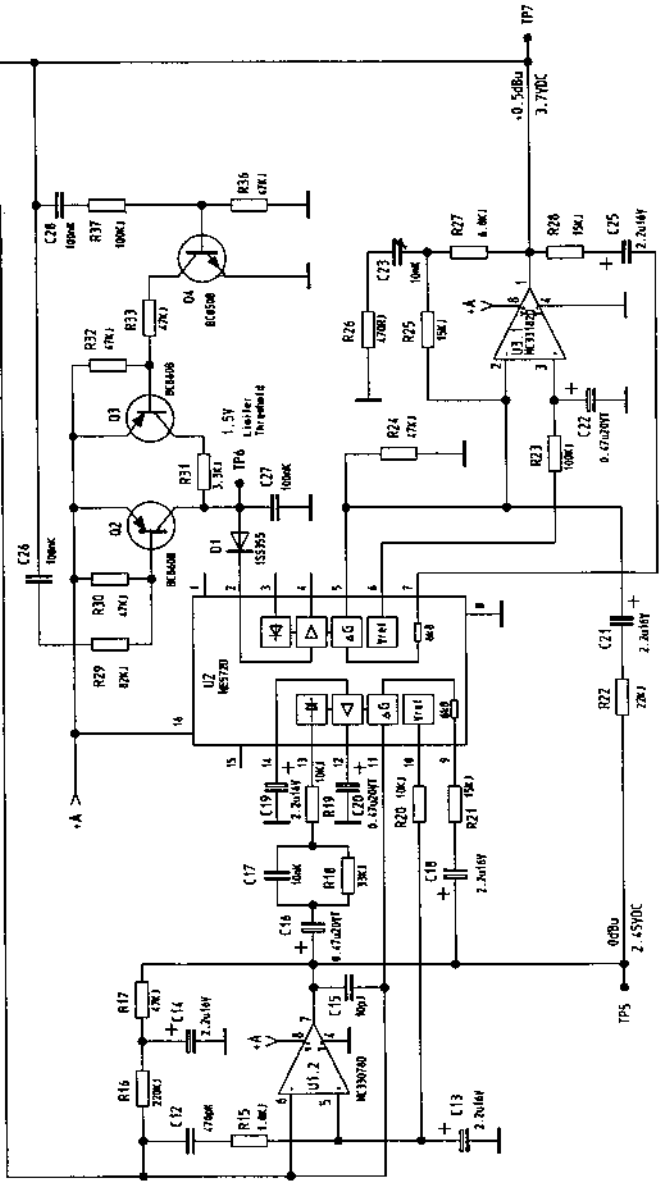

Preemphasis

Compressor

VCA

BF 1081-V, STROMLAUFPLAN, NF-TEIL
 BF 1081-V, CIRCUIT DIAGRAM, AF SECTION

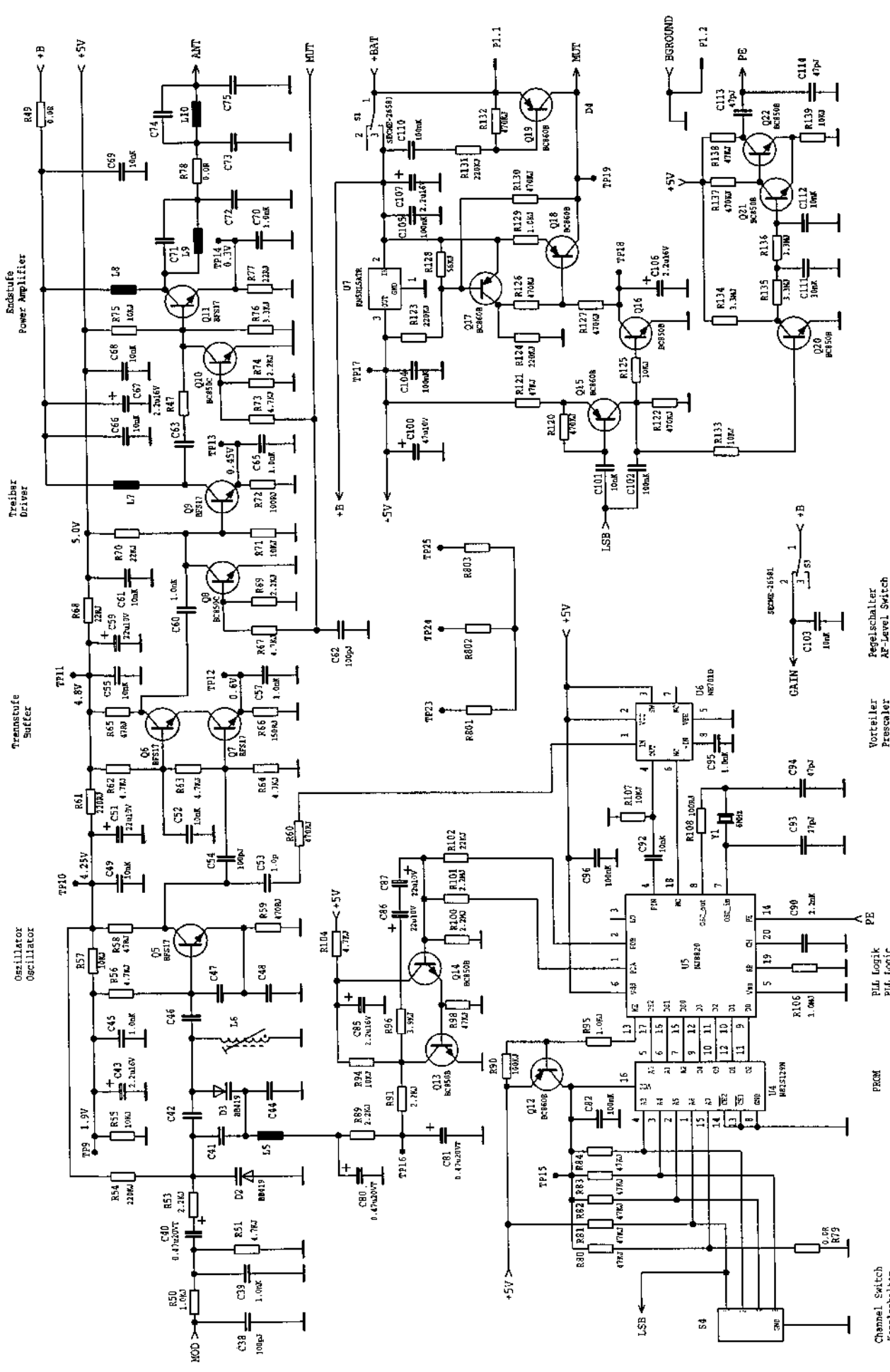

BF 1081-V, STROMLAUFPLAN, HF-TEIL
BF 1081-V, CIRCUIT DIAGRAM, RF SECTION

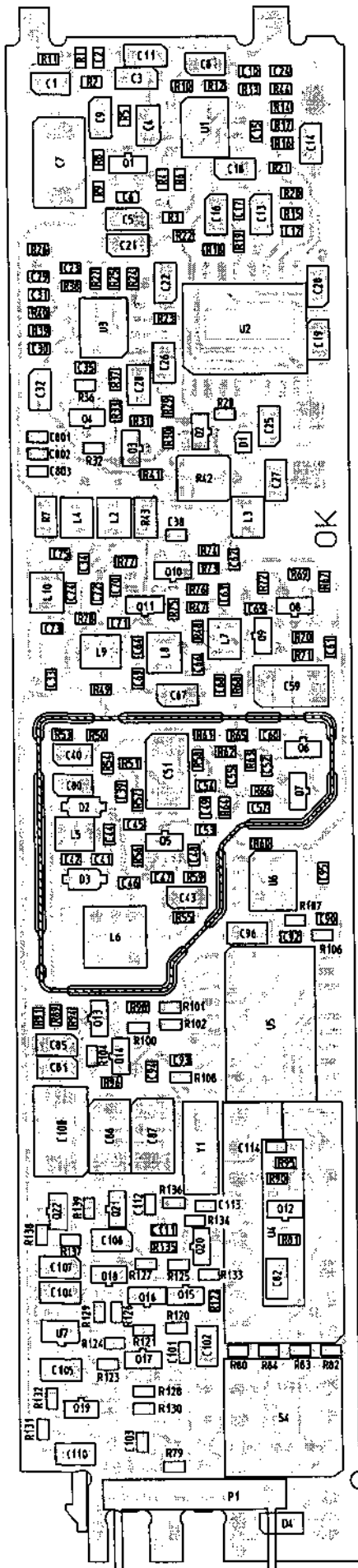

BF 1081-V, GEDRUCKTE SCHALTUNG, BESTÜCKUNGSSEITE
 BF 1081-V, PRINTED CIRCUIT BOARD, COMPONENT SIDE

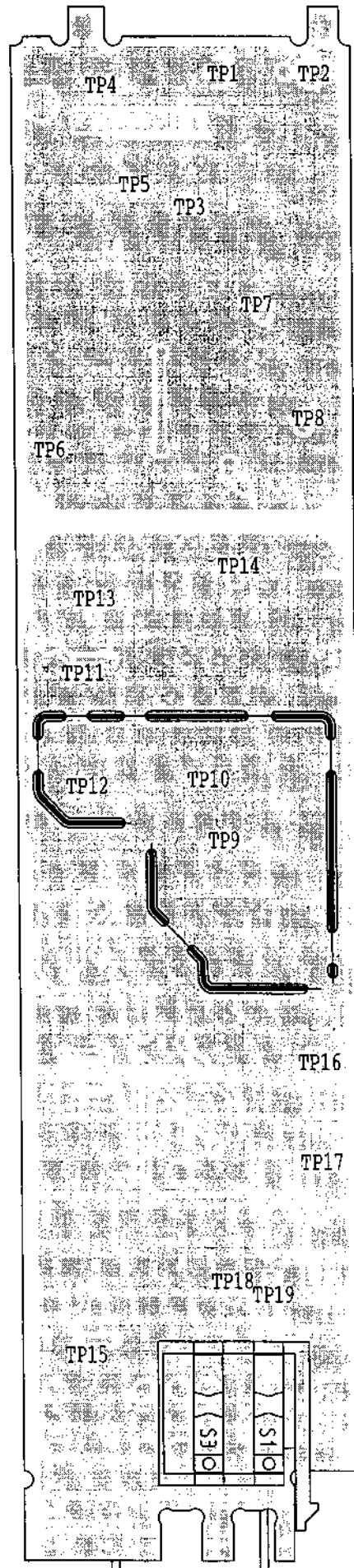

BF 1081-V, GEDRUCKTE SCHALTUNG, LÖTSEITE
 BF 1081-V, PRINTED CIRCUIT BOARD, SOLDER SIDE

11 EXPLOSIONSZEICHNUNG

11 EXPLODED VIEW

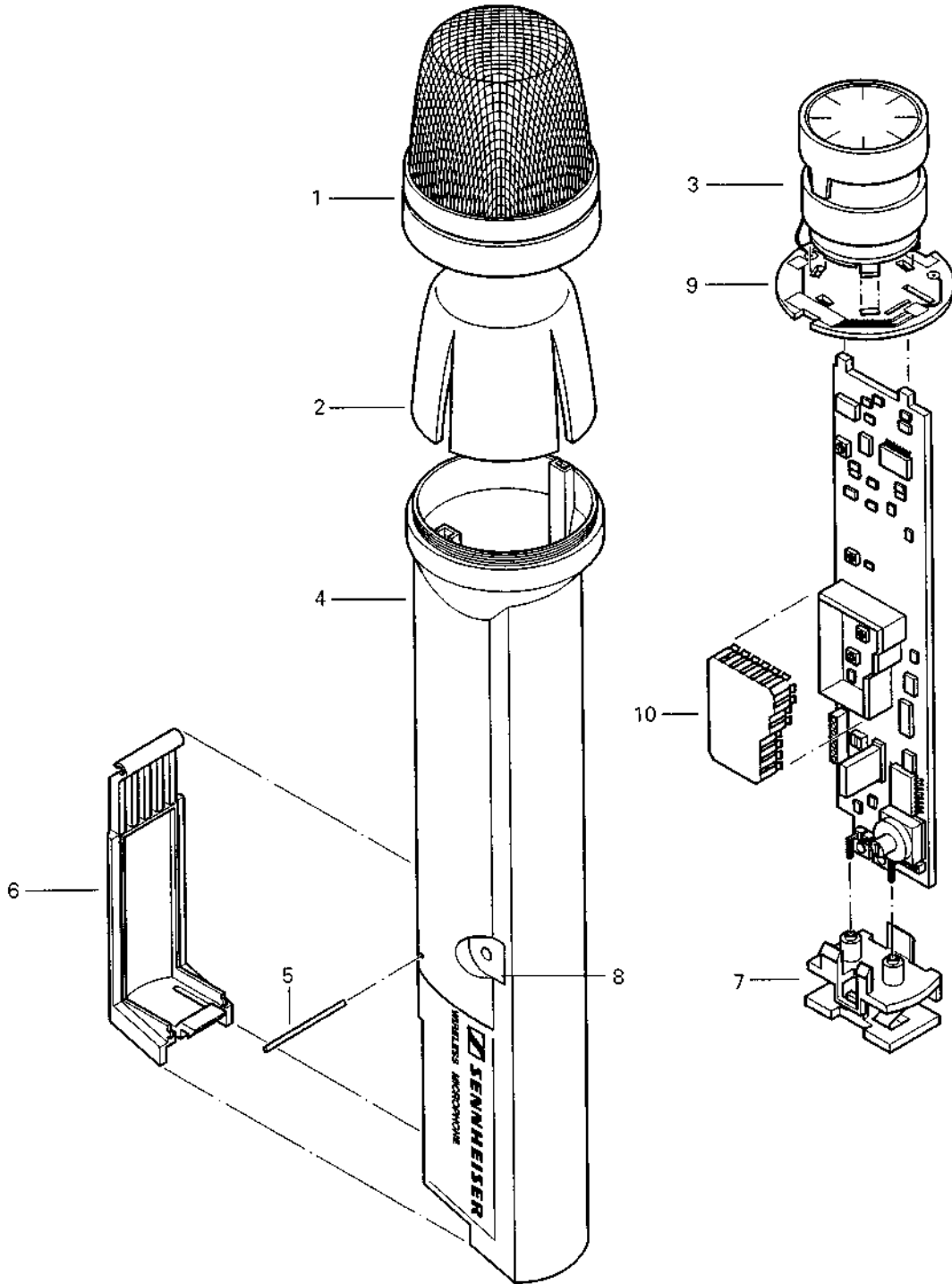

12 ERSATZTEILE

12 SPARE PARTS

POS	IDENT	BEZEICHNUNG	DESCRIPTION
001	49987	Einsprachekorb	Sound inlet basket
002	48139	Poppschutz	Popp shield
003	52534	Kapsel mit Federung + Leiterplatte rund	Capsule with suspension + PCB circular
004	59627	Griff	Handle
005	49999	Zylinderstift (MOQ:10x)	Straight pin (MOQ:10x)
006A	51246	Batterieklappe, schwarz	Cover for battery compartment, black
006B	59658	Batterieklappe -BZT-	Cover for battery compartment -BZT-
007	52704	Kontakteinsatz	Contact insert
008	50930	Bezeichnungsschild, schwarz (1-2-3-4-5-6)	Type plate, black (1-2-3-4-5-6)
009	56280	Leiterplatte	Printed circuit board
010	49668	Abschirmdeckel	Shielding cover
C001	45086	SMD Kondensator TA-KO 100nF 35V (MOQ:50x)	SMD capacitor TA-KO 100nF 35V (MOQ:50x)
C002	45195	SMD Kondensator KERKO 1nF 50V X7R (MOQ:50x)	SMD capacitor KERKO 1nF 50V X7R (MOQ:50x)
C003	45086	SMD Kondensator TA-KO 100nF 35V (MOQ:50x)	SMD capacitor TA-KO 100nF 35V (MOQ:50x)
C004	45086	SMD Kondensator TA-KO 100nF 35V (MOQ:50x)	SMD capacitor TA-KO 100nF 35V (MOQ:50x)
C005	45043	SMD Kondensator TA-KO 2,2uF 16V IEC 384,3	SMD capacitor TA-KO 2.2uF 16V IEC 384,3
C006	45195	SMD Kondensator KERKO 1nF 50V X7R (MOQ:50x)	SMD capacitor KERKO 1nF 50V X7R (MOQ:50x)
C007	45229	SMD Kondensator TA-KO 47uF 10V	SMD capacitor TA-KO 47uF 10V
C008	45050	SMD Kondensator TA-KO 470nF 20V	SMD Capacitor TA-KO 470nF 20V
C010	45199	SMD Kondensator KERKO 4,7nF 50V X7R (MOQ:50x)	SMD capacitor KERKO 4.7nF 50V X7R (MOQ:50x)
C012	45193	SMD Kondensator KERKO 470pF 50V X7R (MOQ:50x)	SMD capacitor KERKO 470pF 50V X7R (MOQ:50x)
C013	45043	SMD Kondensator TA-KO 2,2uF 16V IEC 384,3	SMD capacitor TA-KO 2.2uF 16V IEC 384,3
C014	45043	SMD Kondensator TA-KO 2,2uF 16V IEC 384,3	SMD capacitor TA-KO 2.2uF 16V IEC 384,3
C015	45174	SMD Kondensator KERKO 10pF 50V NPO (MOQ:50x)	SMD capacitor KERKO 10pF 50V NPO (MOQ:50x)
C016	45050	SMD Kondensator TA-KO 470nF 20V	SMD Capacitor TA-KO 470nF 20V
C017	45201	SMD Kondensator KERKO 10nF 50V X7R (MOQ:50x)	SMD capacitor KERKO 10nF 50V X7R (MOQ:50x)
C018	45043	SMD Kondensator TA-KO 2,2uF 16V IEC 384,3	SMD capacitor TA-KO 2.2uF 16V IEC 384,3
C019	45043	SMD Kondensator TA-KO 2,2uF 16V IEC 384,3	SMD capacitor TA-KO 2.2uF 16V IEC 384,3
C020	45050	SMD Kondensator TA-KO 470nF 20V	SMD Capacitor TA-KO 470nF 20V
C021	45043	SMD Kondensator TA-KO 2,2uF 16V IEC 384,3	SMD capacitor TA-KO 2.2uF 16V IEC 384,3
C022	45050	SMD Kondensator TA-KO 470nF 20V	SMD Capacitor TA-KO 470nF 20V
C023	45201	SMD Kondensator KERKO 10nF 50V X7R (MOQ:50x)	SMD capacitor KERKO 10nF 50V X7R (MOQ:50x)
C025	45043	SMD Kondensator TA-KO 2,2uF 16V IEC 384,3	SMD capacitor TA-KO 2.2uF 16V IEC 384,3
C026	19480	SMD Kondensator KERKO 100nF 50V X7R (MOQ:50x)	SMD capacitor KERKO 100nF 50V X7R (MOQ:50x)
C027	19480	SMD Kondensator KERKO 100nF 50V X7R (MOQ:50x)	SMD capacitor KERKO 100nF 50V X7R (MOQ:50x)
C028	19480	SMD Kondensator KERKO 100nF 50V X7R (MOQ:50x)	SMD capacitor KERKO 100nF 50V X7R (MOQ:50x)
C029	45195	SMD Kondensator KERKO 1nF 50V X7R (MOQ:50x)	SMD capacitor KERKO 1nF 50V X7R (MOQ:50x)
C030	45195	SMD Kondensator KERKO 1nF 50V X7R (MOQ:50x)	SMD capacitor KERKO 1nF 50V X7R (MOQ:50x)
C031	45186	SMD Kondensator KERKO 100pF 50V NPO (MOQ:50x)	SMD capacitor KERKO 100pF 50V NPO (MOQ:50x)
C032	45050	SMD Kondensator TA-KO 470nF 20V	SMD Capacitor TA-KO 470nF 20V
C033	45195	SMD Kondensator KERKO 1nF 50V X7R (MOQ:50x)	SMD capacitor KERKO 1nF 50V X7R (MOQ:50x)
C034	45195	SMD Kondensator KERKO 1nF 50V X7R (MOQ:50x)	SMD capacitor KERKO 1nF 50V X7R (MOQ:50x)
C035	45195	SMD Kondensator KERKO 1nF 50V X7R (MOQ:50x)	SMD capacitor KERKO 1nF 50V X7R (MOQ:50x)
C038	45186	SMD Kondensator KERKO 100pF 50V NPO (MOQ:50x)	SMD capacitor KERKO 100pF 50V NPO (MOQ:50x)
C039	45195	SMD Kondensator KERKO 1nF 50V X7R (MOQ:50x)	SMD capacitor KERKO 1nF 50V X7R (MOQ:50x)
C040	45050	SMD Kondensator TA-KO 470nF 20V	SMD Capacitor TA-KO 470nF 20V
C041A	45181	SMD Kondensator KERKO 39pF 50V NPO (MOQ:50x)	SMD capacitor KERKO 39pF 50V NPO (MOQ:50x)
C041B	45180	SMD Kondensator KERKO 33pF 50V NPO (MOQ:50x)	SMD capacitor KERKO 33pF 50V NPO (MOQ:50x)
C041C	45175	SMD Kondensator KERKO 12pF 50V NPO (MOQ:50x)	SMD capacitor KERKO 12pF 50V NPO (MOQ:50x)
C041D	45173	SMD Kondensator KERKO 8,2pF 50V NPO (MOQ:50x)	SMD capacitor KERKO 8.2pF 50V NPO (MOQ:50x)
C041E	45179	SMD Kondensator KERKO 27pF 50V NPO (MOQ:50x)	SMD capacitor KERKO 27pF 50V NPO (MOQ:50x)
C041F	45179	SMD Kondensator KERKO 27pF 50V NPO (MOQ:50x)	SMD capacitor KERKO 27pF 50V NPO (MOQ:50x)
C042A	45173	SMD Kondensator KERKO 8,2pF 50V NPO (MOQ:50x)	SMD capacitor KERKO 8.2pF 50V NPO (MOQ:50x)
C042B	45172	SMD Kondensator KERKO 6,8pF 50V NPO (MOQ:50x)	SMD capacitor KERKO 6.8pF 50V NPO (MOQ:50x)
C042C	45170	SMD Kondensator KERKO 4,7pF 50V NPO KEFQ (MOQ:50x)	SMD capacitor KERKO 4.7pF 50V NPO KEFQ (MOQ:50x)
C042D	45165	SMD Kondensator KERKO 1,8pF 50V NPO (MOQ:50x)	SMD capacitor KERKO 1.8pF 50V NPO (MOQ:50x)
C042E	45169	SMD Kondensator KERKO 3,9pF 50V NPO (MOQ:50x)	SMD capacitor KERKO 3.9pF 50V NPO (MOQ:50x)
C042F	45167	SMD Kondensator KERKO 2,7pF 50V NPO (MOQ:50x)	SMD capacitor KERKO 2.7pF 50V NPO (MOQ:50x)
C043	45043	SMD Kondensator TA-KO 2,2uF 16V IEC 384,3	SMD capacitor TA-KO 2.2uF 16V IEC 384,3

POS	IDENT	BEZEICHNUNG	DESCRIPTION
C044A	45184	SMD Kondensator KERKO 68pF 50V NPO (MOQ:50x) 132-144MHz	SMD capacitor KERKO 68pF 50V NPO (MOQ:50x) 132-144MHz
C044B	45185	SMD Kondensator KERKO 82pF 50V NPO (MOQ:50x) 169-184, 216-235MHz	SMD capacitor KERKO 82pF 50V NPO (MOQ:50x) 169-184, 216-235MHz
C044C	45182	SMD Kondensator KERKO 47pF 50V NPO (MOQ:50x) 183-200, 234-260MHz	SMD capacitor KERKO 47pF 50V NPO (MOQ:50x) 183-200, 234-260MHz
C044D	45179	SMD Kondensator KERKO 27pF 50V NPO (MOQ:50x) 199-217MHz	SMD capacitor KERKO 27pF 50V NPO (MOQ:50x) 199-217MHz
C045	45195	SMD Kondensator KERKO 1nF 50V X7R (MOQ:50x)	SMD capacitor KERKO 1nF 50V X7R (MOQ:50x)
C046A	45176	SMD Kondensator KERKO 15pF 50V NPO (MOQ:50x) 132-184MHz	SMD capacitor KERKO 15pF 50V NPO (MOQ:50x) 132-184MHz
C046B	45177	SMD Kondensator KERKO 18pF 50V NPO (MOQ:50x) 183-217, 234-260MHz	SMD capacitor KERKO 18pF 50V NPO (MOQ:50x) 183-217, 234-260MHz
C046C	45178	SMD Kondensator KERKO 22pF 50V NPO (MOQ:50x) 216-235MHz	SMD capacitor KERKO 22pF 50V NPO (MOQ:50x) 216-235MHz
C047	45175	SMD Kondensator KERKO 12pF 50V NPO (MOQ:50x)	SMD capacitor KERKO 12pF 50V NPO (MOQ:50x)
C048A	45178	SMD Kondensator KERKO 22pF 50V NPO (MOQ:50x) 132-184MHz	SMD capacitor KERKO 22pF 50V NPO (MOQ:50x) 132-184MHz
C048B	45177	SMD Kondensator KERKO 18pF 50V NPO (MOQ:50x) 183-217, 234-260MHz	SMD capacitor KERKO 18pF 50V NPO (MOQ:50x) 183-217, 234-260MHz
C048C	45178	SMD Kondensator KERKO 22pF 50V NPO (MOQ:50x) 216-235MHz	SMD capacitor KERKO 22pF 50V NPO (MOQ:50x) 216-235MHz
C049	45201	SMD Kondensator KERKO 10nF 50V X7R (MOQ:50x)	SMD capacitor KERKO 10nF 50V X7R (MOQ:50x)
C051	41415	SMD Kondensator TA-ELKO 22uF 10V	SMD capacitor TA-ELKO 22uF 10V
C052	45201	SMD Kondensator KERKO 10nF 50V X7R (MOQ:50x)	SMD capacitor KERKO 10nF 50V X7R (MOQ:50x)
C053	45162	SMD Kondensator KERKO 1pF 50V NPO (MOQ:50x)	SMD capacitor KERKO 1pF 50V NPO (MOQ:50x)
C054	45186	SMD Kondensator KERKO 100pF 50V NPO (MOQ:50x)	SMD capacitor KERKO 100pF 50V NPO (MOQ:50x)
C055	45201	SMD Kondensator KERKO 10nF 50V X7R (MOQ:50x)	SMD capacitor KERKO 10nF 50V X7R (MOQ:50x)
C057	45195	SMD Kondensator KERKO 1nF 50V X7R (MOQ:50x)	SMD capacitor KERKO 1nF 50V X7R (MOQ:50x)
C059	41415	SMD Kondensator TA-ELKO 22uF 10V	SMD capacitor TA-ELKO 22uF 10V
C060	45195	SMD Kondensator KERKO 1nF 50V X7R (MOQ:50x)	SMD capacitor KERKO 1nF 50V X7R (MOQ:50x)
C061	45201	SMD Kondensator KERKO 10nF 50V X7R (MOQ:50x)	SMD capacitor KERKO 10nF 50V X7R (MOQ:50x)
C062	45186	SMD Kondensator KERKO 100pF 50V NPO (MOQ:50x)	SMD capacitor KERKO 100pF 50V NPO (MOQ:50x)
C063A	45167	SMD Kondensator KERKO 2,7pF 50V NPO (MOQ:50x) 132-144MHz	SMD capacitor KERKO 2.7pF 50V NPO (MOQ:50x) 132-144MHz
C063B	45171	SMD Kondensator KERKO 5,6pF 50V NPO (MOQ:50x) 169-184MHz	SMD capacitor KERKO 5.6pF 50V NPO (MOQ:50x) 169-184MHz
C063C	45169	SMD Kondensator KERKO 3,9pF 50V NPO (MOQ:50x) 183-217MHz	SMD capacitor KERKO 3.9pF 50V NPO (MOQ:50x) 183-217MHz
C063D	45170	SMD Kondensator KERKO 4,7pF 50V NPO KEFQ (MOQ:50x) 216-235MHz	SMD capacitor KERKO 4.7pF 50V NPO KEFQ (MOQ:50x) 216-235MHz
C063E	45168	SMD Kondensator KERKO 3,3pF 50V NPO (MOQ:50x) 234-260MHz	SMD capacitor KERKO 3.3pF 50V NPO (MOQ:50x) 234-260MHz
C065	45195	SMD Kondensator KERKO 1nF 50V X7R (MOQ:50x)	SMD capacitor KERKO 1nF 50V X7R (MOQ:50x)
C066	45201	SMD Kondensator KERKO 10nF 50V X7R (MOQ:50x)	SMD capacitor KERKO 10nF 50V X7R (MOQ:50x)
C067	45043	SMD Kondensator TA-KO 2,2uF 16V IEC 384,3	SMD capacitor TA-KO 2.2uF 16V IEC 384,3
C068	45201	SMD Kondensator KERKO 10nF 50V X7R (MOQ:50x)	SMD capacitor KERKO 10nF 50V X7R (MOQ:50x)
C069	45201	SMD Kondensator KERKO 10nF 50V X7R (MOQ:50x)	SMD capacitor KERKO 10nF 50V X7R (MOQ:50x)
C070	45195	SMD Kondensator KERKO 1nF 50V X7R (MOQ:50x)	SMD capacitor KERKO 1nF 50V X7R (MOQ:50x)
C071A	45179	SMD Kondensator KERKO 27pF 50V NPO (MOQ:50x) 132-144MHz	SMD capacitor KERKO 27pF 50V NPO (MOQ:50x) 132-144MHz
C071B	45178	SMD Kondensator KERKO 22pF 50V NPO (MOQ:50x) 169-200MHz	SMD capacitor KERKO 22pF 50V NPO (MOQ:50x) 169-200MHz
C071C	45176	SMD Kondensator KERKO 15pF 50V NPO (MOQ:50x) 199-217MHz	SMD capacitor KERKO 15pF 50V NPO (MOQ:50x) 199-217MHz
C071D	45177	SMD Kondensator KERKO 18pF 50V NPO (MOQ:50x) 216-260MHz	SMD capacitor KERKO 18pF 50V NPO (MOQ:50x) 216-260MHz
C072A	45180	SMD Kondensator KERKO 33pF 50V NPO (MOQ:50x) 132-144, 169-184MHz	SMD capacitor KERKO 33pF 50V NPO (MOQ:50x) 132-144, 169-184MHz
C072B	45178	SMD Kondensator KERKO 22pF 50V NPO (MOQ:50x) 183-217, 234-260MHz	SMD capacitor KERKO 22pF 50V NPO (MOQ:50x) 183-217, 234-260MHz
C072C	45179	SMD Kondensator KERKO 27pF 50V NPO (MOQ:50x) 216-235MHz	SMD capacitor KERKO 27pF 50V NPO (MOQ:50x) 216-235MHz
C073A	45175	SMD Kondensator KERKO 12pF 50V NPO (MOQ:50x) 132-144MHz	SMD capacitor KERKO 12pF 50V NPO (MOQ:50x) 132-144MHz
C073B	45176	SMD Kondensator KERKO 15pF 50V NPO (MOQ:50x) 169-184MHz	SMD capacitor KERKO 15pF 50V NPO (MOQ:50x) 169-184MHz
C073C	45173	SMD Kondensator KERKO 8,2pF 50V NPO (MOQ:50x) 183-200MHz	SMD capacitor KERKO 8.2pF 50V NPO (MOQ:50x) 183-200MHz
C073D	45174	SMD Kondensator KERKO 10pF 50V NPO (MOQ:50x) 199-217MHz	SMD capacitor KERKO 10pF 50V NPO (MOQ:50x) 199-217MHz
C073E	45172	SMD Kondensator KERKO 6,8pF 50V NPO (MOQ:50x) 216-235MHz	SMD capacitor KERKO 6.8pF 50V NPO (MOQ:50x) 216-235MHz

POS	IDENT	BEZEICHNUNG	DESCRIPTION
C073F	45171	SMD Kondensator KERKO 5,6pF 50V NPO (MOQ:50x) 234-260MHz	SMD capacitor KERKO 5.6pF 50V NPO (MOQ:50x) 234-260MHz
C074A	45172	SMD Kondensator KERKO 6,8pF 50V NPO (MOQ:50x) 132-144, 169-184MHz	SMD capacitor KERKO 6.8pF 50V NPO (MOQ:50x) 132-144, 169-184MHz
C074B	45171	SMD Kondensator KERKO 5,6pF 50V NPO (MOQ:50x) 183-200MHz	SMD capacitor KERKO 5.6pF 50V NPO (MOQ:50x) 183-200MHz
C074C	45170	SMD Kondensator KERKO 4,7pF 50V NPO KEFQ (MOQ:50x) 199-217MHz	SMD capacitor KERKO 4.7pF 50V NPO KEFQ (MOQ:50x) 199-217MHz
C074D	45169	SMD Kondensator KERKO 3,9pF 50V NPO (MOQ:50x) 216-235MHz	SMD capacitor KERKO 3.9pF 50V NPO (MOQ:50x) 216-235MHz
C074E	45168	SMD Kondensator KERKO 3,3pF 50V NPO (MOQ:50x) 234-260MHz	SMD capacitor KERKO 3.3pF 50V NPO (MOQ:50x) 234-260MHz
C075A	45180	SMD Kondensator KERKO 33pF 50V NPO (MOQ:50x) 132-144, 169-184MHz	SMD capacitor KERKO 33pF 50V NPO (MOQ:50x) 132-144, 169-184MHz
C075B	45178	SMD Kondensator KERKO 22pF 50V NPO (MOQ:50x) 183-260MHz	SMD capacitor KERKO 22pF 50V NPO (MOQ:50x) 183-260MHz
C080	45050	SMD Kondensator TA-KO 470nF 20V	SMD Capacitor TA-KO 470nF 20V
C081	45050	SMD Kondensator TA-KO 470nF 20V	SMD Capacitor TA-KO 470nF 20V
C082	19480	SMD Kondensator KERKO 100nF 50V X7R (MOQ:50x)	SMD capacitor KERKO 100nF 50V X7R (MOQ:50x)
C085	45043	SMD Kondensator TA-KO 2,2uF 16V IEC 384,3	SMD capacitor TA-KO 2.2uF 16V IEC 384,3
C086	41415	SMD Kondensator TA-ELKO 22uF 10V	SMD capacitor TA-ELKO 22uF 10V
C087	41415	SMD Kondensator TA-ELKO 22uF 10V	SMD capacitor TA-ELKO 22uF 10V
C090	45197	SMD Kondensator KERKO 2,2nF 50V X7R (MOQ:50x)	SMD capacitor KERKO 2.2nF 50V X7R (MOQ:50x)
C092	45201	SMD Kondensator KERKO 10nF 50V X7R (MOQ:50x)	SMD capacitor KERKO 10nF 50V X7R (MOQ:50x)
C093	45179	SMD Kondensator KERKO 27pF 50V NPO (MOQ:50x)	SMD capacitor KERKO 27pF 50V NPO (MOQ:50x)
C094	45182	SMD Kondensator KERKO 47pF 50V NPO (MOQ:50x)	SMD capacitor KERKO 47pF 50V NPO (MOQ:50x)
C095	45195	SMD Kondensator KERKO 1nF 50V X7R (MOQ:50x)	SMD capacitor KERKO 1nF 50V X7R (MOQ:50x)
C096	19480	SMD Kondensator KERKO 100nF 50V X7R (MOQ:50x)	SMD capacitor KERKO 100nF 50V X7R (MOQ:50x)
C100	45229	SMD Kondensator TA-KO 47uF 10V	SMD capacitor TA-KO 47uF 10V
C101	45201	SMD Kondensator KERKO 10nF 50V X7R (MOQ:50x)	SMD capacitor KERKO 10nF 50V X7R (MOQ:50x)
C102	19480	SMD Kondensator KERKO 100nF 50V X7R (MOQ:50x)	SMD capacitor KERKO 100nF 50V X7R (MOQ:50x)
C103	45201	SMD Kondensator KERKO 10nF 50V X7R (MOQ:50x)	SMD capacitor KERKO 10nF 50V X7R (MOQ:50x)
C104	19480	SMD Kondensator KERKO 100nF 50V X7R (MOQ:50x)	SMD capacitor KERKO 100nF 50V X7R (MOQ:50x)
C105	19480	SMD Kondensator KERKO 100nF 50V X7R (MOQ:50x)	SMD capacitor KERKO 100nF 50V X7R (MOQ:50x)
C106	45043	SMD Kondensator TA-KO 2,2uF 16V IEC 384,3	SMD capacitor TA-KO 2.2uF 16V IEC 384,3
C107	45043	SMD Kondensator TA-KO 2,2uF 16V IEC 384,3	SMD capacitor TA-KO 2.2uF 16V IEC 384,3
C110	19480	SMD Kondensator KERKO 100nF 50V X7R (MOQ:50x)	SMD capacitor KERKO 100nF 50V X7R (MOQ:50x)
C111	45201	SMD Kondensator KERKO 10nF 50V X7R (MOQ:50x)	SMD capacitor KERKO 10nF 50V X7R (MOQ:50x)
C112	45201	SMD Kondensator KERKO 10nF 50V X7R (MOQ:50x)	SMD capacitor KERKO 10nF 50V X7R (MOQ:50x)
C113	45182	SMD Kondensator KERKO 47pF 50V NPO (MOQ:50x)	SMD capacitor KERKO 47pF 50V NPO (MOQ:50x)
C114	45182	SMD Kondensator KERKO 47pF 50V NPO (MOQ:50x)	SMD capacitor KERKO 47pF 50V NPO (MOQ:50x)
D001	45444	SMD Diode 1SS355	SMD diode 1SS355
D002	45304	SMD Varicap BB419 SOD123	SMD Varicap BB419 SOT123
D003	45304	SMD Varicap BB419 SOD123	SMD Varicap BB419 SOT123
L002	32123	SMD Spule 4,7uH	SMD coil 4.7uH
L003	32123	SMD Spule 4,7uH	SMD coil 4.7uH
L004A	45495	SMD Spule 150nH SUP8 132-144MHz	SMD coil 150nH SUP8 132-144MHz
L004B	46989	SMD Spule 100nH SUP8 169-200MHz	SMD coil 100nH SUP8 169-200MHz
L004C	45615	SMD Spule 68nH 199-235MHz	SMD coil 68nH 199-235MHz
L004D	45494	SMD Spule 47nH SUP8 234-260MHz	SMD coil 47nH SUP8 234-260MHz
L005	32123	SMD Spule 4,7uH	SMD coil 4.7uH
L006A	45722	SMD HF Spule 132-144MHz	SMD RF coil 132-144MHz
L006B	45723	SMD HF Spule 169-217MHz	SMD RF coil 169-217MHz
L006C	45724	SMD HF Spule 216-260MHz	SMD RF coil 216-260MHz
L007A	37190	SMD Spule 390 nH 132-144MHz	SMD coil 390nH 132-144MHz
L007B	45495	SMD Spule 150nH SUP8 169-217MHz	SMD coil 150nH SUP8 169-217MHz
L007C	46989	SMD Spule 100nH SUP8 216-260MHz	SMD coil 100nH SUP8 216-260MHz
L008A	45615	SMD Spule 68nH 132-144MHz	SMD coil 68nH 132-144MHz
L008B	45494	SMD Spule 47nH SUP8 169-217MHz	SMD coil 47nH SUP8 169-217MHz
L008C	45493	SMD Spule 33nH SUP8 216-260MHz	SMD coil 33nH SUP8 216-260MHz

POS	IDENT	BEZEICHNUNG	DESCRIPTION
L010A	45494	SMD Spule 47nH SUP8 132-144MHz	SMD coil 47nH SUP8 132-144MHz
L010B	45493	SMD Spule 33nH SUP8 169-260MHz	SMD coil 33nH SUP8 169-260MHz
Q001	21165	SMD Transistor BC850C SOT23	SMD transistor BC850C SOT23
Q002	32468	SMD Transistor BC860B SOT23	SMD transistor BC860B SOT23
Q003	32468	SMD Transistor BC860B SOT23	SMD transistor BC860B SOT23
Q004	32467	SMD Transistor BC850B SOT23	SMD transistor BC850B SOT23
Q005	27023	SMD Transistor BFS17 SOT23	SMD transistor BFS17 SOT23
Q006	27023	SMD Transistor BFS17 SOT23	SMD transistor BFS17 SOT23
Q007	27023	SMD Transistor BFS17 SOT23	SMD transistor BFS17 SOT23
Q008	21165	SMD Transistor BC850C SOT23	SMD transistor BC850C SOT23
Q009	27023	SMD Transistor BFS17 SOT23	SMD transistor BFS17 SOT23
Q010	21165	SMD Transistor BC850C SOT23	SMD transistor BC850C SOT23
Q011	27023	SMD Transistor BFS17 SOT23	SMD transistor BFS17 SOT23
Q012	32468	SMD Transistor BC860B SOT23	SMD transistor BC860B SOT23
Q013	32467	SMD Transistor BC850B SOT23	SMD transistor BC850B SOT23
Q014	32467	SMD Transistor BC850B SOT23	SMD transistor BC850B SOT23
Q015	32468	SMD Transistor BC860B SOT23	SMD transistor BC860B SOT23
Q016	32467	SMD Transistor BC850B SOT23	SMD transistor BC850B SOT23
Q017	32468	SMD Transistor BC860B SOT23	SMD transistor BC860B SOT23
Q018	32468	SMD Transistor BC860B SOT23	SMD transistor BC860B SOT23
Q019	32468	SMD Transistor BC860B SOT23	SMD transistor BC860B SOT23
Q020	32467	SMD Transistor BC850B SOT23	SMD transistor BC850B SOT23
Q021	32467	SMD Transistor BC850B SOT23	SMD transistor BC850B SOT23
Q022	32467	SMD Transistor BC850B SOT23	SMD transistor BC850B SOT23
R001	45139	SMD Widerstand 15k 5% 0603 (MOQ:50x)	SMD resistor 15k 5% 0603 (MOQ:50x)
R002	45124	SMD Widerstand 47R 5% 0603 (MOQ:50x)	SMD resistor 47R 5% 0603 (MOQ:50x)
R003	45144	SMD Widerstand 100k 5% 0603 (MOQ:50x)	SMD resistor 100k 5% 0603 (MOQ:50x)
R004	45221	SMD Widerstand 82k 5% 0603 (MOQ:50x)	SMD resistor 82k 5% 0603 (MOQ:50x)
R005	45136	SMD Widerstand 4k7 5% 0603 (MOQ:50x)	SMD resistor 4k7 5% 0603 (MOQ:50x)
R006	45144	SMD Widerstand 100k 5% 0603 (MOQ:50x)	SMD resistor 100k 5% 0603 (MOQ:50x)
R007	19507	SMD Widerstand 33k 5% 1206 (MOQ:50x)	SMD resistor 33k 5% 1206 (MOQ:50x)
R008	45128	SMD Widerstand 220R 5% 0603 (MOQ:50x)	SMD resistor 220R 5% 0603 (MOQ:50x)
R009	45135	SMD Widerstand 3k3 5% 0603 (MOQ:50x)	SMD resistor 3k3 5% 0603 (MOQ:50x)
R010	45136	SMD Widerstand 4k7 5% 0603 (MOQ:50x)	SMD resistor 4k7 5% 0603 (MOQ:50x)
R013	45143	SMD Widerstand 68k 5% 0603 (MOQ:50x)	SMD resistor 68k 5% 0603 (MOQ:50x)
R014	45140	SMD Widerstand 22k 5% 0603 (MOQ:50x)	SMD resistor 22k 5% 0603 (MOQ:50x)
R015	45132	SMD Widerstand 1k 5% 0603 (MOQ:50x)	SMD resistor 1k 5% 0603 (MOQ:50x)
R016	45146	SMD Widerstand 220k 5% 0603 (MOQ:50x)	SMD resistor 220k 5% 0603 (MOQ:50x)
R017	45142	SMD Widerstand 47k 5% 0603 (MOQ:50x)	SMD resistor 47k 5% 0603 (MOQ:50x)
R018	45141	SMD Widerstand 33k 5% 0603 (MOQ:50x)	SMD resistor 33k 5% 0603 (MOQ:50x)
R019	45138	SMD Widerstand 10k 5% 0603 (MOQ:50x)	SMD resistor 10k 5% 0603 (MOQ:50x)
R020	45138	SMD Widerstand 10k 5% 0603 (MOQ:50x)	SMD resistor 10k 5% 0603 (MOQ:50x)
R021	45139	SMD Widerstand 15k 5% 0603 (MOQ:50x)	SMD resistor 15k 5% 0603 (MOQ:50x)
R022	45140	SMD Widerstand 22k 5% 0603 (MOQ:50x)	SMD resistor 22k 5% 0603 (MOQ:50x)
R023	45144	SMD Widerstand 100k 5% 0603 (MOQ:50x)	SMD resistor 100k 5% 0603 (MOQ:50x)
R024	45142	SMD Widerstand 47k 5% 0603 (MOQ:50x)	SMD resistor 47k 5% 0603 (MOQ:50x)
R025	45139	SMD Widerstand 15k 5% 0603 (MOQ:50x)	SMD resistor 15k 5% 0603 (MOQ:50x)
R026	45130	SMD Widerstand 470R 5% 0603 (MOQ:50x)	SMD resistor 470R 5% 0603 (MOQ:50x)
R027	45137	SMD Widerstand 6k8 5% 0603 (MOQ:50x)	SMD resistor 6k8 5% 0603 (MOQ:50x)
R028	45139	SMD Widerstand 15k 5% 0603 (MOQ:50x)	SMD resistor 15k 5% 0603 (MOQ:50x)
R029	45221	SMD Widerstand 82k 5% 0603 (MOQ:50x)	SMD resistor 82k 5% 0603 (MOQ:50x)
R030	45142	SMD Widerstand 47k 5% 0603 (MOQ:50x)	SMD resistor 47k 5% 0603 (MOQ:50x)
R031	45135	SMD Widerstand 3k3 5% 0603 (MOQ:50x)	SMD resistor 3k3 5% 0603 (MOQ:50x)
R032	45142	SMD Widerstand 47k 5% 0603 (MOQ:50x)	SMD resistor 47k 5% 0603 (MOQ:50x)
R033	45142	SMD Widerstand 47k 5% 0603 (MOQ:50x)	SMD resistor 47k 5% 0603 (MOQ:50x)
R036	45142	SMD Widerstand 47k 5% 0603 (MOQ:50x)	SMD resistor 47k 5% 0603 (MOQ:50x)
R037	45144	SMD Widerstand 100k 5% 0603 (MOQ:50x)	SMD resistor 100k 5% 0603 (MOQ:50x)
R038	45136	SMD Widerstand 4k7 5% 0603 (MOQ:50x)	SMD resistor 4k7 5% 0603 (MOQ:50x)
R039	45137	SMD Widerstand 6k8 5% 0603 (MOQ:50x)	SMD resistor 6k8 5% 0603 (MOQ:50x)
R040	45141	SMD Widerstand 33k 5% 0603 (MOQ:50x)	SMD resistor 33k 5% 0603 (MOQ:50x)
R042	45003	SMD Trimmwiderstand 50k	SMD resistor, variable 50k
R043	19507	SMD Widerstand 33k 5% 1206 (MOQ:50x)	SMD resistor 33k 5% 1206 (MOQ:50x)
R047A	45126	SMD Widerstand 100R 5% 0603 (MOQ:50x) 132-144, 169-184MHz	SMD resistor 100R 5% 0603 (MOQ:50x) 132-144, 169-184MHz
R047B	45125	SMD Widerstand 68R 5% 0603 (MOQ:50x) 183-200MHz	SMD resistor 68R 5% 0603 (MOQ:50x) 183-200MHz
R047C	45123	SMD Widerstand 33R 5% 0603 (MOQ:50x) 199-217MHz	SMD resistor 33R 5% 0603 (MOQ:50x) 199-217MHz
R047D	45122	SMD Widerstand 22R 5% 0603 (MOQ:50x) 216-260MHz	SMD resistor 22R 5% 0603 (MOQ:50x) 216-260MHz
R049	45295	SMD Widerstand 0R 0603 (MOQ:50x)	SMD resistor 0R 0603 (MOQ:50x)

POS	IDENT	BEZEICHNUNG	DESCRIPTION
R050	45132	SMD Widerstand 1k 5% 0603 (MOQ:50x)	SMD resistor 1k 5% 0603 (MOQ:50x)
R051	45136	SMD Widerstand 4k7 5% 0603 (MOQ:50x)	SMD resistor 4k7 5% 0603 (MOQ:50x)
R053	45134	SMD Widerstand 2k2 5% 0603 (MOQ:50x)	SMD resistor 2k2 5% 0603 (MOQ:50x)
R054	45146	SMD Widerstand 220k 5% 0603 (MOQ:50x)	SMD resistor 220k 5% 0603 (MOQ:50x)
R055	45138	SMD Widerstand 10k 5% 0603 (MOQ:50x)	SMD resistor 10k 5% 0603 (MOQ:50x)
R056	45136	SMD Widerstand 4k7 5% 0603 (MOQ:50x)	SMD resistor 4k7 5% 0603 (MOQ:50x)
R057	45138	SMD Widerstand 10k 5% 0603 (MOQ:50x)	SMD resistor 10k 5% 0603 (MOQ:50x)
R058	45124	SMD Widerstand 47R 5% 0603 (MOQ:50x)	SMD resistor 47R 5% 0603 (MOQ:50x)
R059	45130	SMD Widerstand 470R 5% 0603 (MOQ:50x)	SMD resistor 470R 5% 0603 (MOQ:50x)
R060	45130	SMD Widerstand 470R 5% 0603 (MOQ:50x)	SMD resistor 470R 5% 0603 (MOQ:50x)
R061	45128	SMD Widerstand 220R 5% 0603 (MOQ:50x)	SMD resistor 220R 5% 0603 (MOQ:50x)
R062	45136	SMD Widerstand 4k7 5% 0603 (MOQ:50x)	SMD resistor 4k7 5% 0603 (MOQ:50x)
R063	45136	SMD Widerstand 4k7 5% 0603 (MOQ:50x)	SMD resistor 4k7 5% 0603 (MOQ:50x)
R064	45136	SMD Widerstand 4k7 5% 0603 (MOQ:50x)	SMD resistor 4k7 5% 0603 (MOQ:50x)
R065	45124	SMD Widerstand 47R 5% 0603 (MOQ:50x)	SMD resistor 47R 5% 0603 (MOQ:50x)
R066	45127	SMD Widerstand 150R 5% 0603 (MOQ:50x)	SMD resistor 150R 5% 0603 (MOQ:50x)
R067	45136	SMD Widerstand 4k7 5% 0603 (MOQ:50x)	SMD resistor 4k7 5% 0603 (MOQ:50x)
R068	45122	SMD Widerstand 22R 5% 0603 (MOQ:50x)	SMD resistor 22R 5% 0603 (MOQ:50x)
R069	45134	SMD Widerstand 2k2 5% 0603 (MOQ:50x)	SMD resistor 2k2 5% 0603 (MOQ:50x)
R070	45140	SMD Widerstand 22k 5% 0603 (MOQ:50x)	SMD resistor 22k 5% 0603 (MOQ:50x)
R071	45138	SMD Widerstand 10k 5% 0603 (MOQ:50x)	SMD resistor 10k 5% 0603 (MOQ:50x)
R072	45126	SMD Widerstand 100R 5% 0603 (MOQ:50x)	SMD resistor 100R 5% 0603 (MOQ:50x)
R073	45136	SMD Widerstand 4k7 5% 0603 (MOQ:50x)	SMD resistor 4k7 5% 0603 (MOQ:50x)
R074	45134	SMD Widerstand 2k2 5% 0603 (MOQ:50x)	SMD resistor 2k2 5% 0603 (MOQ:50x)
R075	45138	SMD Widerstand 10k 5% 0603 (MOQ:50x)	SMD resistor 10k 5% 0603 (MOQ:50x)
R076	45135	SMD Widerstand 3k3 5% 0603 (MOQ:50x)	SMD resistor 3k3 5% 0603 (MOQ:50x)
R077	45122	SMD Widerstand 22R 5% 0603 (MOQ:50x)	SMD resistor 22R 5% 0603 (MOQ:50x)
R078	45295	SMD Widerstand 0R 0603 (MOQ:50x)	SMD resistor 0R 0603 (MOQ:50x)
R079	45295	SMD Widerstand 0R 0603 (MOQ:50x)	SMD resistor 0R 0603 (MOQ:50x)
R080	45142	SMD Widerstand 47k 5% 0603 (MOQ:50x)	SMD resistor 47k 5% 0603 (MOQ:50x)
R081	45142	SMD Widerstand 47k 5% 0603 (MOQ:50x)	SMD resistor 47k 5% 0603 (MOQ:50x)
R082	45142	SMD Widerstand 47k 5% 0603 (MOQ:50x)	SMD resistor 47k 5% 0603 (MOQ:50x)
R083	45142	SMD Widerstand 47k 5% 0603 (MOQ:50x)	SMD resistor 47k 5% 0603 (MOQ:50x)
R084	45142	SMD Widerstand 47k 5% 0603 (MOQ:50x)	SMD resistor 47k 5% 0603 (MOQ:50x)
R089	45134	SMD Widerstand 2k2 5% 0603 (MOQ:50x)	SMD resistor 2k2 5% 0603 (MOQ:50x)
R090	45144	SMD Widerstand 100k 5% 0603 (MOQ:50x)	SMD resistor 100k 5% 0603 (MOQ:50x)
R091	45134	SMD Widerstand 2k2 5% 0603 (MOQ:50x)	SMD resistor 2k2 5% 0603 (MOQ:50x)
R094	45138	SMD Widerstand 10k 5% 0603 (MOQ:50x)	SMD resistor 10k 5% 0603 (MOQ:50x)
R095	45132	SMD Widerstand 1k 5% 0603 (MOQ:50x)	SMD resistor 1k 5% 0603 (MOQ:50x)
R096	45213	SMD Widerstand 3k9 5% 0603 (MOQ:50x)	SMD resistor 3k9 5% 0603 (MOQ:50x)
R098	45142	SMD Widerstand 47k 5% 0603 (MOQ:50x)	SMD resistor 47k 5% 0603 (MOQ:50x)
R100	45151	SMD Widerstand 2M2 10% 0603 (MOQ:50x)	SMD resistor 2M2 10% 0603 (MOQ:50x)
R101	45151	SMD Widerstand 2M2 10% 0603 (MOQ:50x)	SMD resistor 2M2 10% 0603 (MOQ:50x)
R102	45140	SMD Widerstand 22k 5% 0603 (MOQ:50x)	SMD resistor 22k 5% 0603 (MOQ:50x)
R104	45136	SMD Widerstand 4k7 5% 0603 (MOQ:50x)	SMD resistor 4k7 5% 0603 (MOQ:50x)
R106	45150	SMD Widerstand 1M 5% 0603 (MOQ:50x)	SMD resistor 1M 5% 0603 (MOQ:50x)
R107	45138	SMD Widerstand 10k 5% 0603 (MOQ:50x)	SMD resistor 10k 5% 0603 (MOQ:50x)
R108	45126	SMD Widerstand 100R 5% 0603 (MOQ:50x)	SMD resistor 100R 5% 0603 (MOQ:50x)
R120	45148	SMD Widerstand 470k 5% 0603 (MOQ:50x)	SMD resistor 470k 5% 0603 (MOQ:50x)
R121	45142	SMD Widerstand 47k 5% 0603 (MOQ:50x)	SMD resistor 47k 5% 0603 (MOQ:50x)
R122	45148	SMD Widerstand 470k 5% 0603 (MOQ:50x)	SMD resistor 470k 5% 0603 (MOQ:50x)
R123	45146	SMD Widerstand 220k 5% 0603 (MOQ:50x)	SMD resistor 220k 5% 0603 (MOQ:50x)
R124	45146	SMD Widerstand 220k 5% 0603 (MOQ:50x)	SMD resistor 220k 5% 0603 (MOQ:50x)
R125	45138	SMD Widerstand 10k 5% 0603 (MOQ:50x)	SMD resistor 10k 5% 0603 (MOQ:50x)
R126	45148	SMD Widerstand 470k 5% 0603 (MOQ:50x)	SMD resistor 470k 5% 0603 (MOQ:50x)
R127	45148	SMD Widerstand 470k 5% 0603 (MOQ:50x)	SMD resistor 470k 5% 0603 (MOQ:50x)
R128	45220	SMD Widerstand 56k 5% 0603 (MOQ:50x)	SMD resistor 56k 5% 0603 (MOQ:50x)
R129	45132	SMD Widerstand 1k 5% 0603 (MOQ:50x)	SMD resistor 1k 5% 0603 (MOQ:50x)
R130	45148	SMD Widerstand 470k 5% 0603 (MOQ:50x)	SMD resistor 470k 5% 0603 (MOQ:50x)
R131	45146	SMD Widerstand 220k 5% 0603 (MOQ:50x)	SMD resistor 220k 5% 0603 (MOQ:50x)
R132	45148	SMD Widerstand 470k 5% 0603 (MOQ:50x)	SMD resistor 470k 5% 0603 (MOQ:50x)
R133	45138	SMD Widerstand 10k 5% 0603 (MOQ:50x)	SMD resistor 10k 5% 0603 (MOQ:50x)
R134	45292	SMD Widerstand 3M3 10% 0603 (MOQ:50x)	SMD resistor 3M3 10% 0603 (MOQ:50x)
R135	45292	SMD Widerstand 3M3 10% 0603 (MOQ:50x)	SMD resistor 3M3 10% 0603 (MOQ:50x)
R136	45292	SMD Widerstand 3M3 10% 0603 (MOQ:50x)	SMD resistor 3M3 10% 0603 (MOQ:50x)
R137	45148	SMD Widerstand 470k 5% 0603 (MOQ:50x)	SMD resistor 470k 5% 0603 (MOQ:50x)
R138	45142	SMD Widerstand 47k 5% 0603 (MOQ:50x)	SMD resistor 47k 5% 0603 (MOQ:50x)
R139	45138	SMD Widerstand 10k 5% 0603 (MOQ:50x)	SMD resistor 10k 5% 0603 (MOQ:50x)
R801	45295	SMD Widerstand 0R 0603 (MOQ:50x)	SMD resistor 0R 0603 (MOQ:50x)
		146-157,169-184,199-217,234-260MHz	146-157,169-184,199-217,234-260MHz
R802	45295	SMD Widerstand 0R 0603 (MOQ:50x)	SMD resistor 0R 0603 (MOQ:50x)
		132-144, 169-200, 234-260MHz	132-144, 169-200, 234-260MHz

POS	IDENT	BEZEICHNUNG	DESCRIPTION
R803	45295	SMD Widerstand 0R 0603 (MOQ:50x) 169-235MHz	SMD resistor 0R 0603 (MOQ:50x) 169-235MHz
S001	26581	Schiebeschalter	Slide switch
S003	26581	Schiebeschalter	Slide switch
S004	45595	Codierschalter	Code switch
U001	41277	SMD IC MC33078D SO8 SUP8	SMD IC MC33078D SO8 SUP8
U002	45093	SMD IC NE572D SOL16	SMD IC NE572D SOL16
U003	45873	SMD IC 2xPB.OP MC33182D	SMD IC 2xPB.OP MC33182D
U004	40095	IC PROM 1Kx4 N82S129N (unprogrammiert!)	IC PROM 1Kx4 N82S129N (not programmed!)
U005	45034	SMD IC CMOS NJ8820 MP20	SMD IC CMOS NJ8820 MP20
U006	45508	SMD IC NE701D SO8	SMD IC NE701D SO8
U007	45726	SMD IC RN5RL5ATR	SMD IC RN5RL5ATR
Y001	45309	Quarz 6MHz	Crystal 6MHz
ZZ020	59815	Bedienungsanleitung BF1081V	Instructions for use BF1081V