

Dual

Service-Anleitung Service Manual Instructions de Service

CV 650 RC

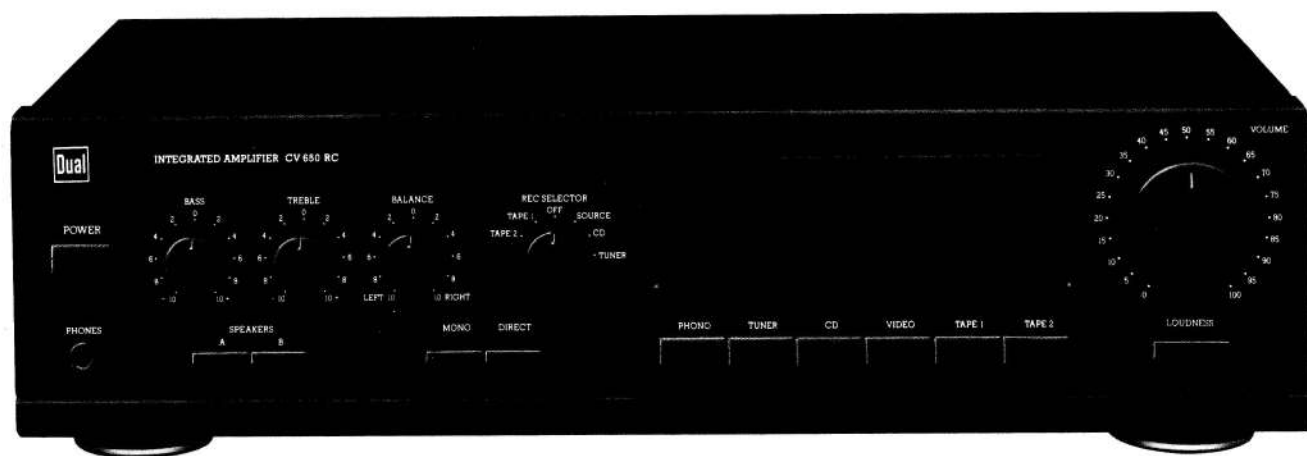

Technische Daten (typische Werte)	Specifications (typical values)	Caractéristiques techniques (valeurs types)	Dati tecnici (valori tipici)	CV 650 RC
Ausgangsleistung Sinusleistung (8/4 Ω DIN 1 kHz) Musikleistung (8/4 Ω 1 kHz)	Power output RMS continuous power output (8/4 Ω DIN 1 kHz) music power (8/4 Ω 1 kHz)	Puissance de sortie Puissance sinus (8/4 ohms DIN 1 kHz) Puissance musique (8/4 ohms 1 kHz)	Potenza d'uscita capacità sinusoidale (8/4 ohm DIN 1 kHz) Potenza musicale (8/4 ohm 1 kHz)	2 × 85 W/2 × 110 W 2 × 110 W/2 × 130 W
Leistungsbandbreite	Frequency response	Bande de puissance	Banda di potenza	10–80000 Hz
Klirrfaktor bei 2/3 Leistung (1 kHz)	Harmonic distortion	Distorsion à 2/3 de puissance (1 kHz)	Distorsione armonica a 2/3 de rendimento (1 kHz)	< 0,01 %
Fremdspannungsabstand bezogen auf Nennleistung Phono-Eingang Hochpegel-Eingänge (CD, VIDEO, TAPE, TUNER)	Signal/noise ratio referred to rated power output Phono input High-level inputs (CD, VIDEO, TAPE, TUNER)	Rapport non pondéré son/bruit par rapport à la puissance nominale Entrée Phono Entrées haut niveau (CD, VIDEO, TAPE, TUNER)	Selettività riferita alla potenza nominale ingresso phono ingressi ad alte impedenze (CD, VIDEO, TAPE, TUNER)	72 dB 95 dB
Übersprechdämpfung	Crosstalk attenuation	Diaphonie	Diafonia	80 dB
Eingänge CD, VIDEO, TAPE, TUNER PHONO	Inputs CD, VIDEO, TAPE, TUNER PHONO	Entrées CD, VIDEO, TAPE, TUNER PHONO	Ingressi CD, VIDEO, TAPE, TUNER PHONO	200 mV/47 kΩ 2,5 mV/47 kΩ
Ausgänge Druckklemmen für zwei Lautsprecherpaare 1-Koaxialbuchse ¼ inch für Kopfhörer TAPE 1/TAPE 2	Outputs Clamping terminals für zwei speaker pairs 1 coaxial jack, ¼ inch, for headphones TAPE 1/TAPE 2	Sorties Bornes à pression pour deux paires de haut-parleurs 1 prise coaxiale ¼" pour écouteurs TAPE 1/TAPE 2	Uscite morsetti di pressione per due coppie di diffusori 1 presa coassiale ¼" per cuffia TAPE 1/TAPE 2	8–16 Ohm
Leistungsaufnahme (maximal)	Power input (maximum)	Consommation de courant (maximum)	Potenza assorbita (massimo)	400 Watt
Netzspannung Model Europa Model USA/Kanada	Mains voltage European model US/Canadian model	Voltage secteur Modèle Europe Modèle USA/Canada	Tensione di rete modello Europa modello Stati Uniti/Canada	230 V/50 Hz 115 V/60 Hz
Maße (Breite × Höhe × Tiefe)	Dimensions (width × height × depth)	Dimensions (largeur × hauteur × profondeur)	Dimensioni (larghezza × altezza × profondità)	440 × 122 × 245 mm

Dual GmbH · Postfach 1144 · 7742 St. Georgen/Schwarzwald

BLOCK DIAGRAM

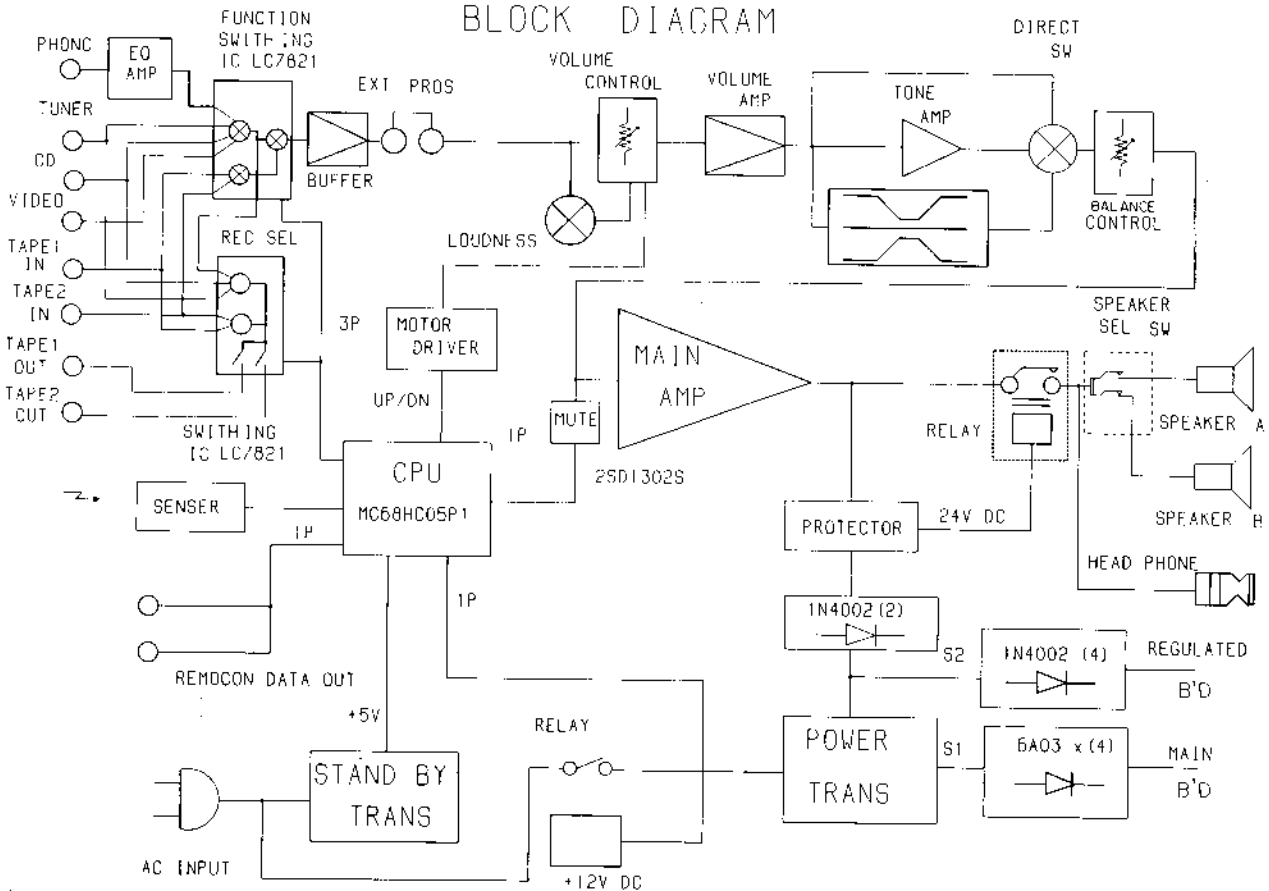

LC 7821 IC 107 (SWITCHING IC)

PIN No.	Terminal	Description
1	NC	
2	CD	Input/output terminals of audio signal of left channel
3	TUNER	
4	SOURCE	
5		Control to the inside analog switch at the serial data
6	TAPE 1	
7	TAPE 2	
8		
9	TAPE 1 OUT	
10	TAPE 2 OUT	
11		
12	Vee	Negative power supply terminal (-18V)
13	STROBE	Serial Control terminal
14	DATA	Connect terminal of MB88P 515B
15	CLOCK	
16	Vss	
17	S	High Level (+18V)
18	RES	Reset terminal When power is turned ON the Condition of the analog switch is not determined, but when this terminal is „L“ all analog switches are OFF
19	VDD	Power Supply terminal (-18V)
20	DATA OUTPUT	
21	TAPE 2 OUT	Input/Output terminals of audio signal of right channel
22	TAPE 1 OUT	
23		
24	TAPE 2	Control to the inside analog switch at the serial date
25	TAPE 1	
26		
27	SOURCE	
28	TUNER	
29	CD	
30	NC	

(MC68HC05C4P: IC 501)

No.	Terminal	Operating	Remark
1	Reset		Q502
2	IRO		5V
3	NC		
4	PA7 (OFF)		
5	PA6 (TUNER) REC		5V
6	PA5 (CD) SELECTOR	0V	
7	PA4 (SOURCE)		
8	PA3 (T1)		
9	PA2 (T2)		
10	PA1 (GND)		
11	PA0 (GND)		5V
12	PB0	0V	
13	(STAND-BY RELAY)		
14	PB1 (STAND-BY LED)	0V	Q501
15	PB2 (MAIN MUTE)		200 m sec
16	PB3 (REC SEL MUTE)		6 m sec
17	PB4 NC		
18	PB5 (VOL UP)		
19	PB6 (VOL DOWN)		
20	PB7 (MOL LED)		Q201
21	VSS		
22	PC7 (RMC OUT)		
23	PC6 (STROBE LCD)		
24	PC5 (CLK)		
25	PC4 (DATA)		
26	PC3 (STROBE SW/IC)		
27	PC2 (INH)		
28	PC1 (KEY SCAN 2)		KEY MATRIX
29	PC0 (KEY SCAN 1)	5V	KEY MATRIX
30	PD0 (KEY IN 3)	0V	KEY MATRIX
31	PD1 (KEY IN 2)		KEY MATRIX
32	PD2 (KEY IN 1)		KEY MATRIX
33	PD3 (NC)		
34	PD4		
35	PD5 +5V (AC CORD OFF CHECK)	0V	
36	TCMP (NC)		
37	PD7 (RMC IN)		
38	TCAP (NC)		
39	OSC2		4 MHz
40	OSC1		OSC 4MHz
41	VDD		

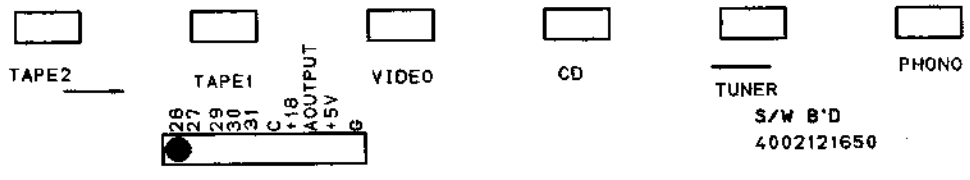

TONE B'D
4002121610

ST-BY KEY

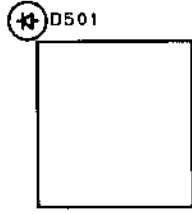
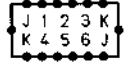
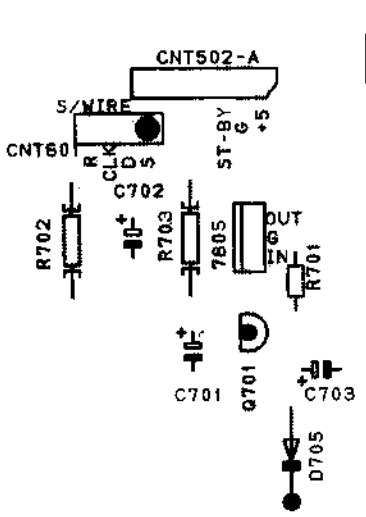

REMOTE
SENSOR

FUSE B'D
4002121620

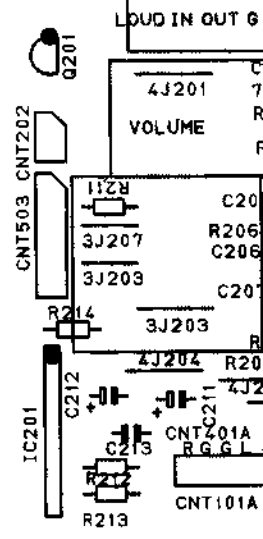
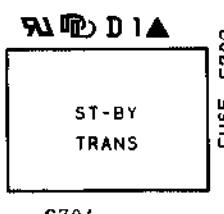
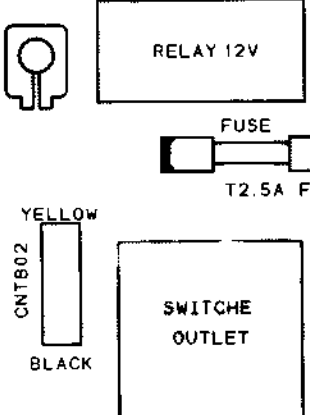

MAIN B'D
4002121600

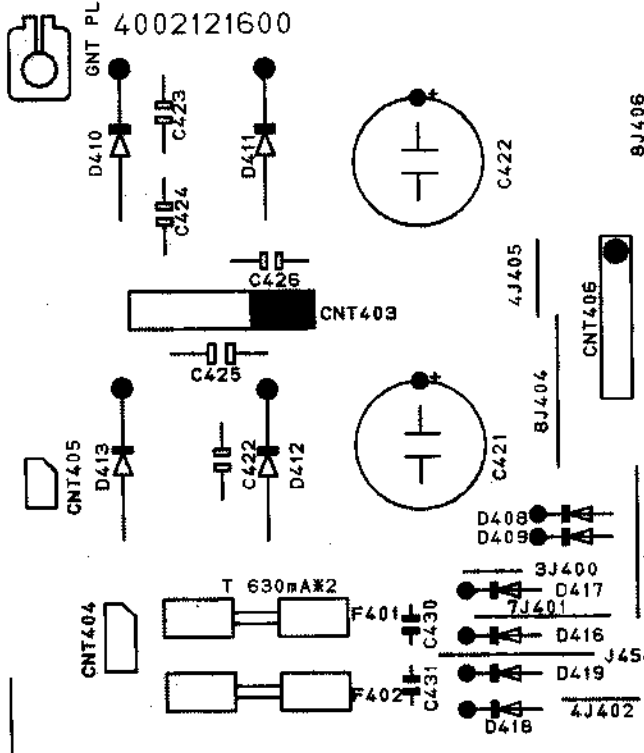

B C E Q411L Q408L B C E Q412L

ST-BY KEY

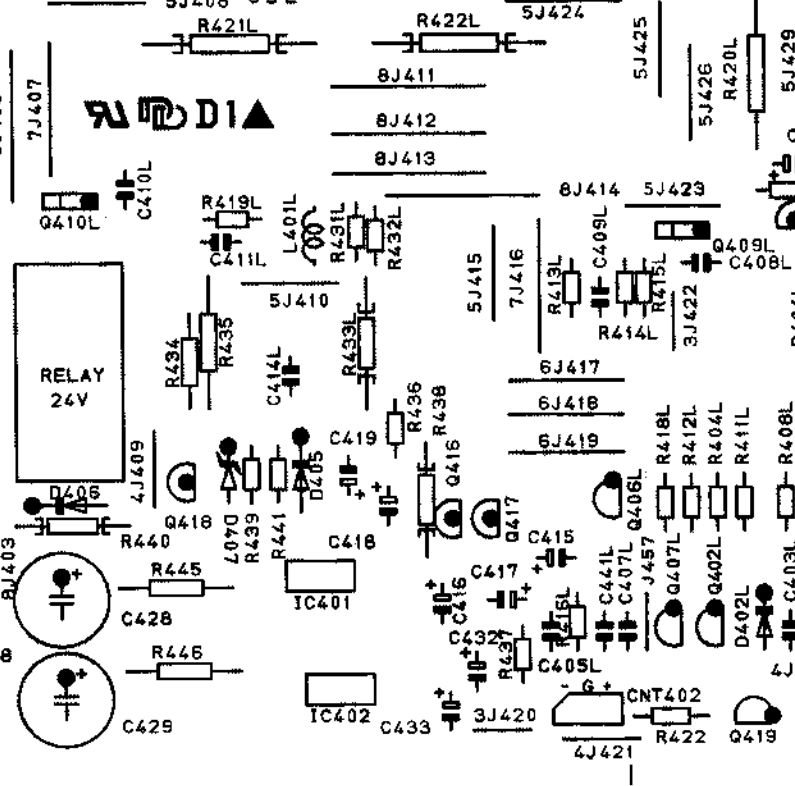

STONE B'D
4002121610

ST-BY KEY

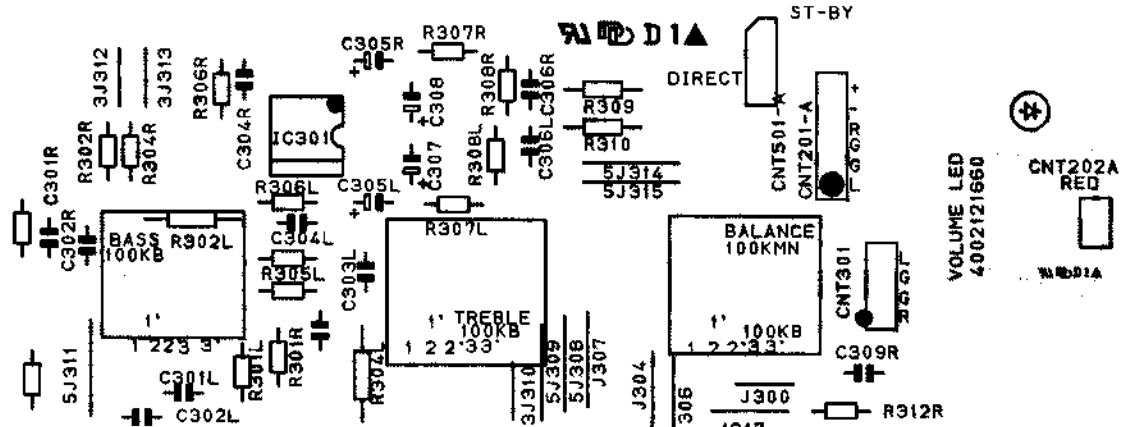

NOTE
INSOR

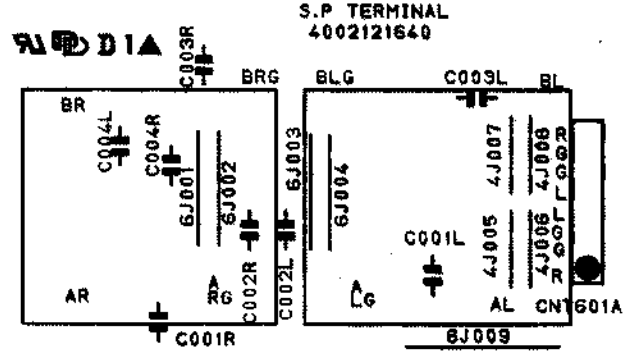
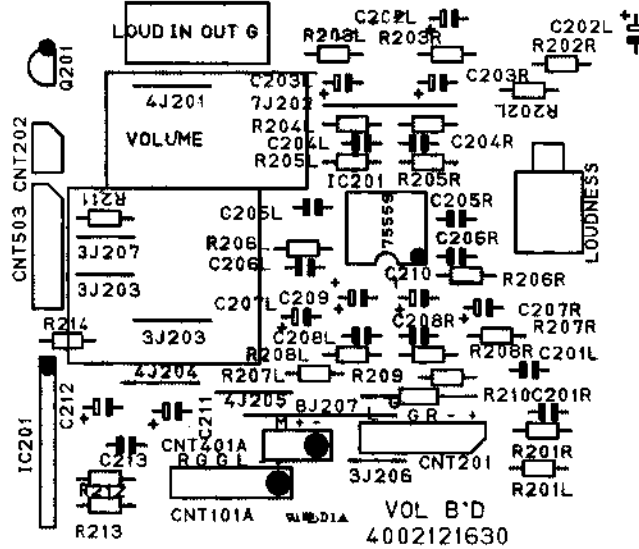

B C E Q412L

B C E Q412R CBE Q408R B C E Q411R

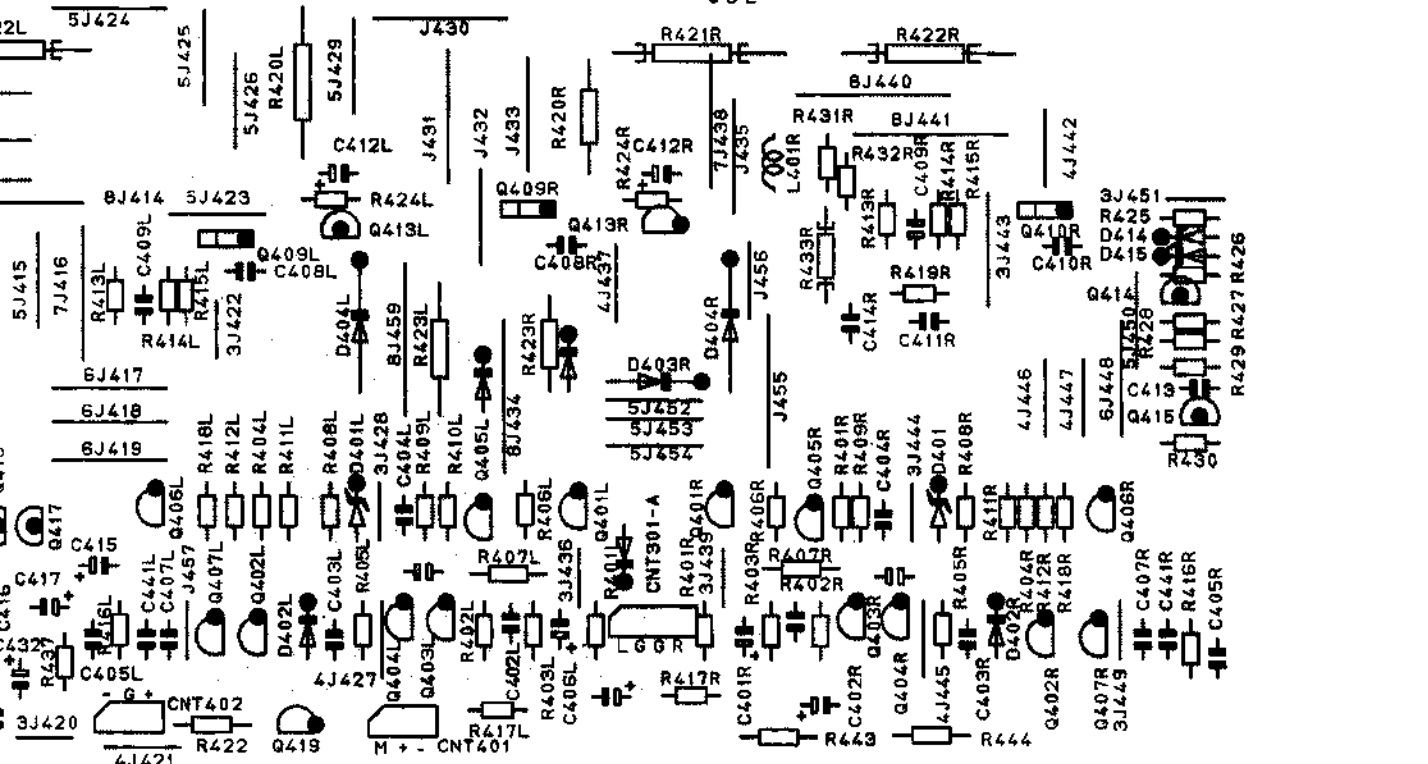

HEADPHONE B'D 4002121720

SPEAKER TERMINAL B'D 4002121640

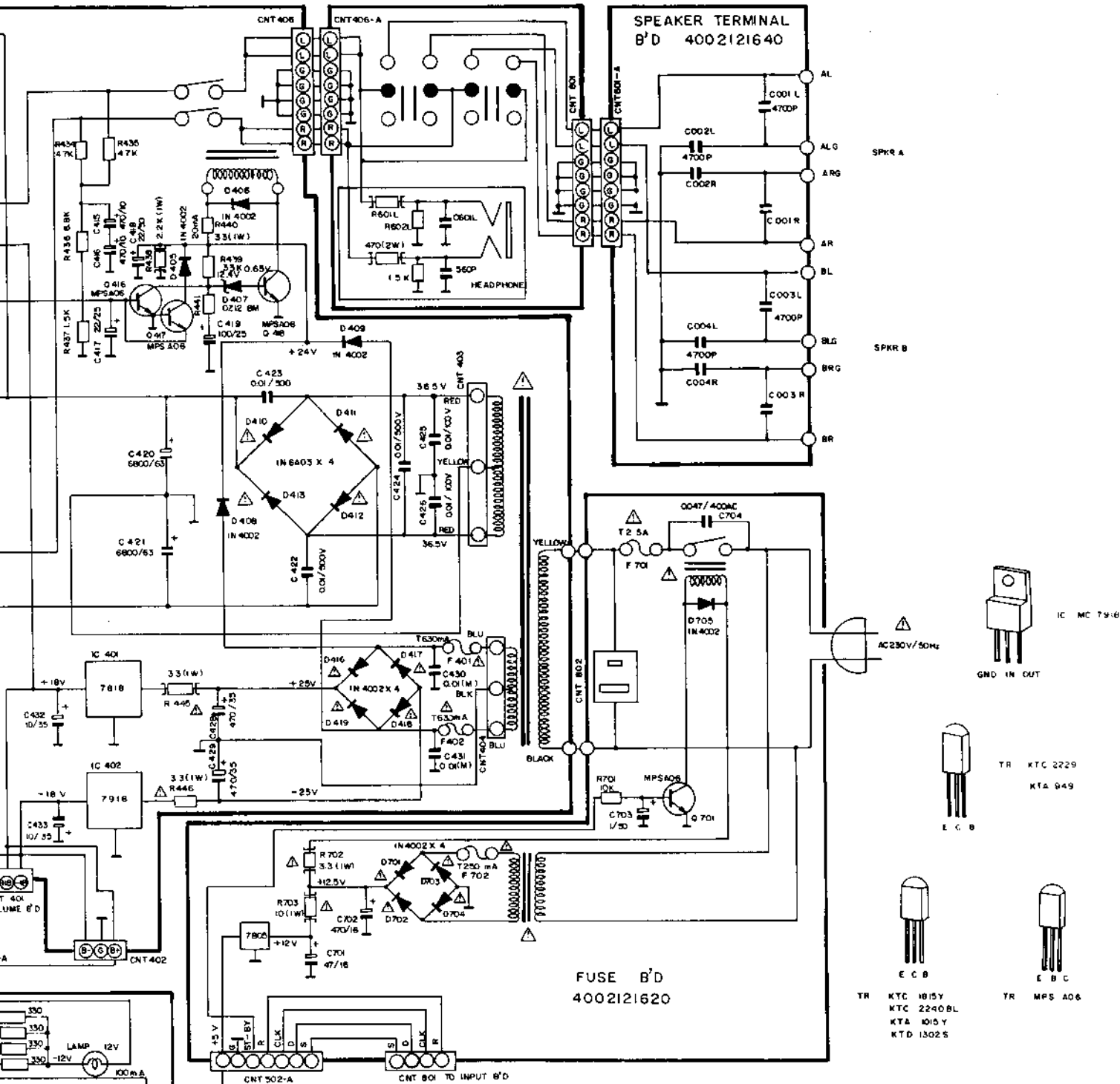

- IC MC 7916
- GND IN OUT
- TR KTC 2229
- KTA 949
- E C B
- TR KTC 1815Y
- KTC 2240BL
- KTA 1015 Y
- KTD 1302S
- E C B
- E B C
- TR 25C 3655
- 25A 1491
- TR 25C 3421
- 25A 1558
- B C E
- IC GD 7818
- GD 7805
- IN GND OUT
- B C E

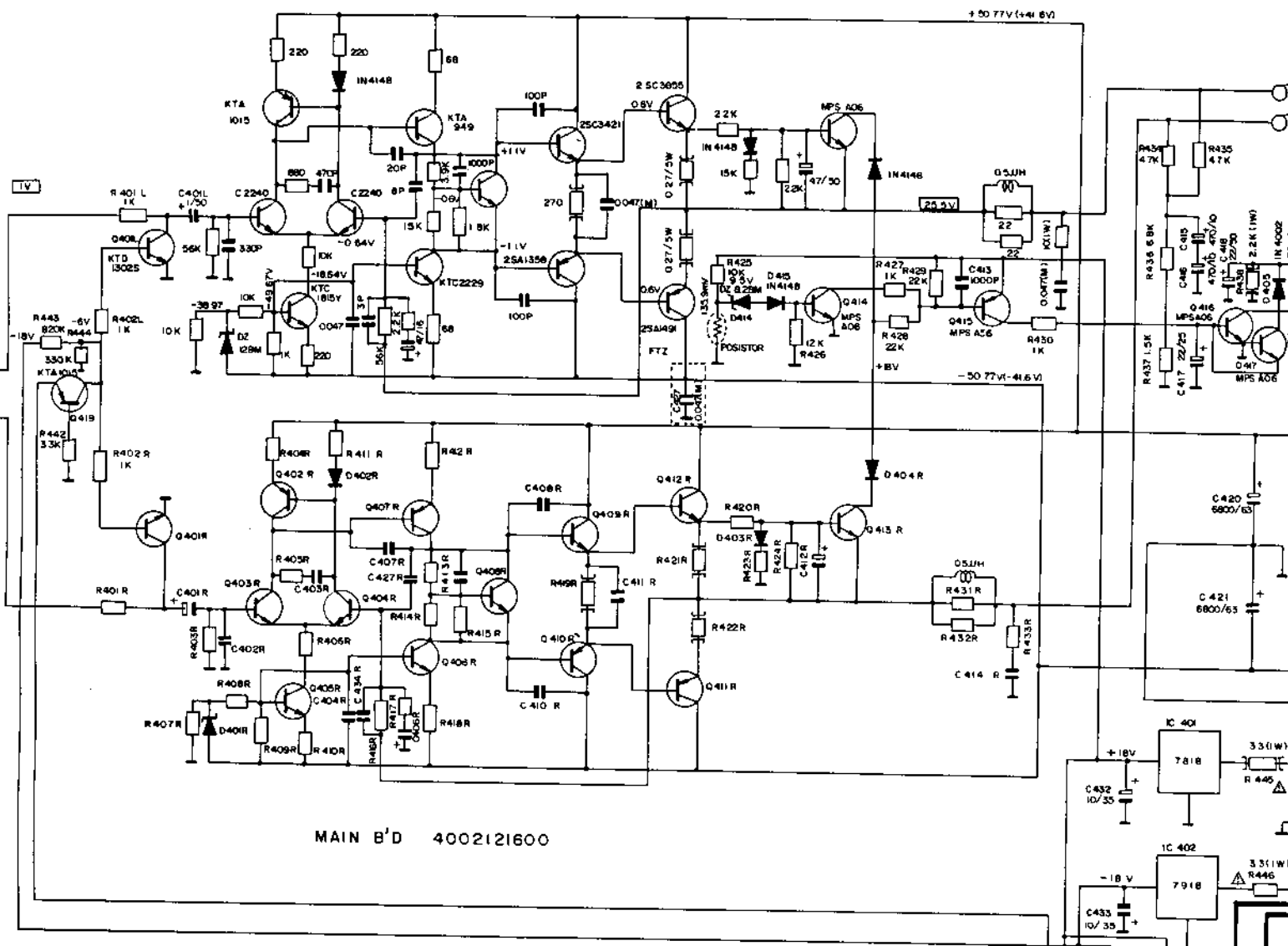

MAIN B'D 4002121600

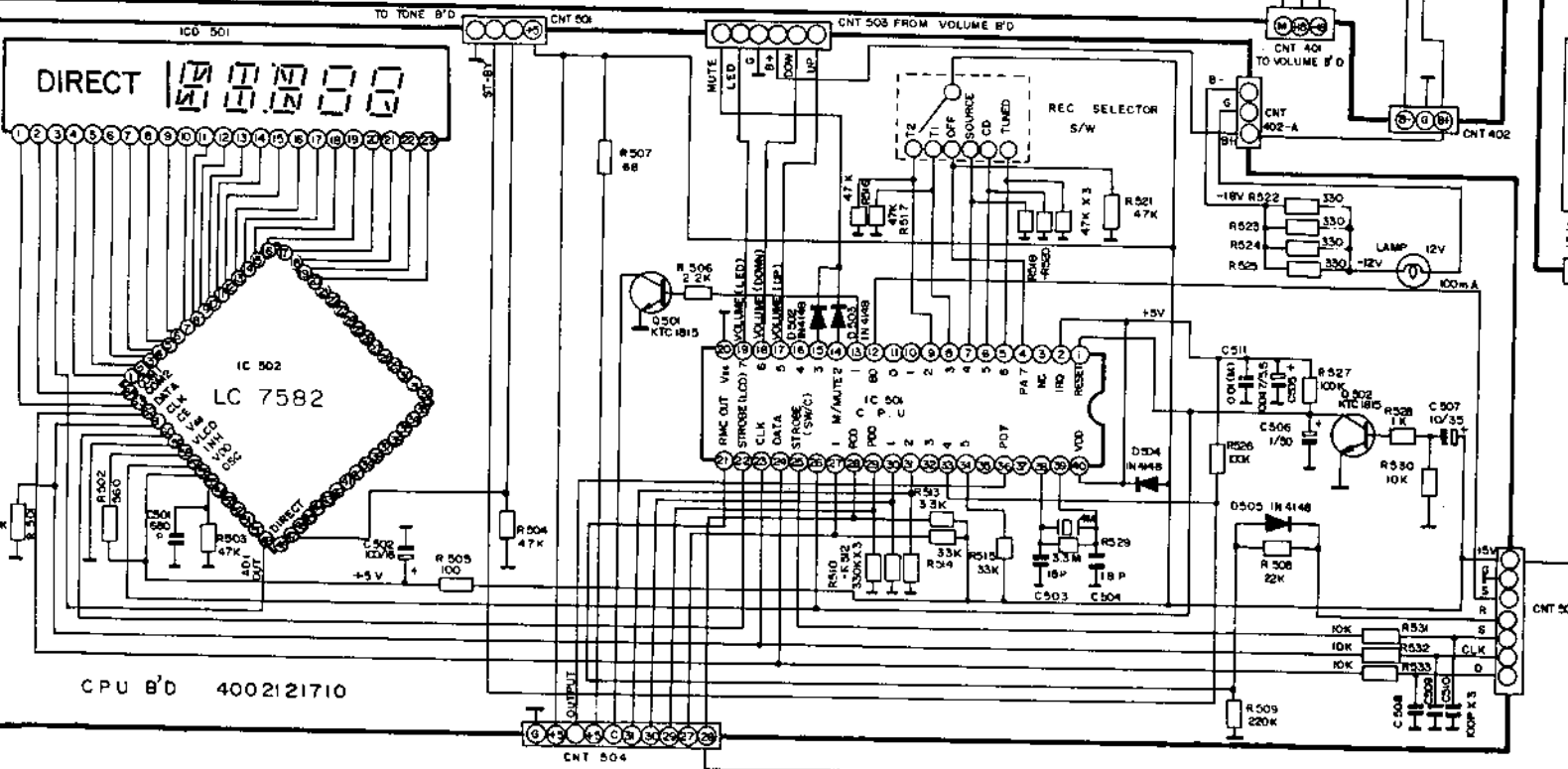

CPU B'D 4002121710

INPUT B.D 4002121700

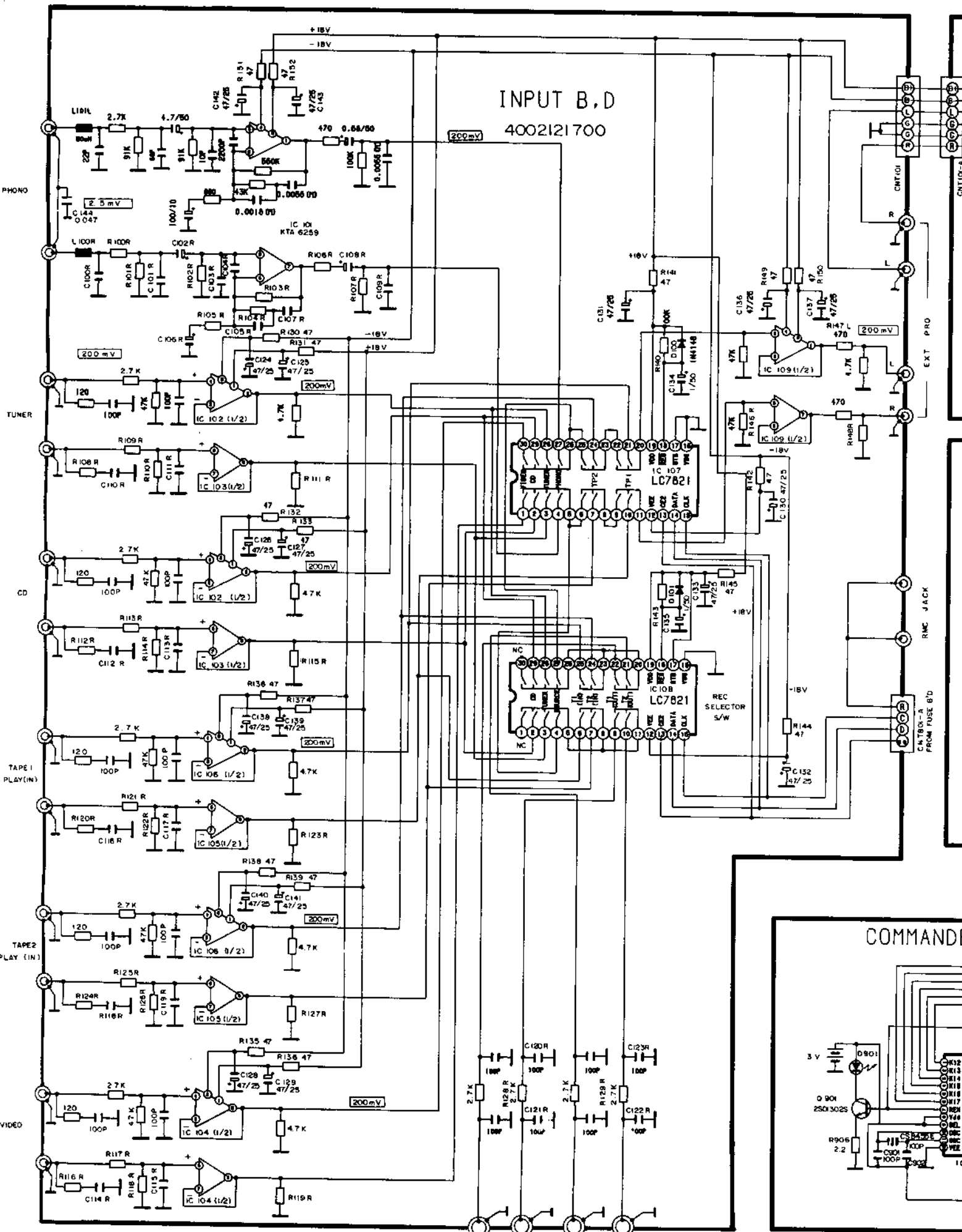

COMMANDE

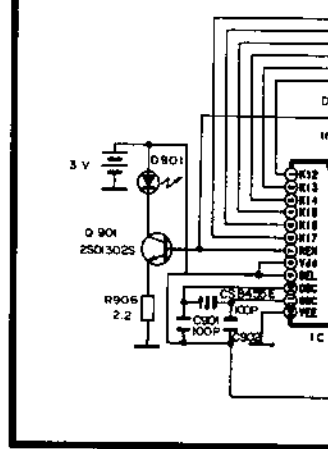

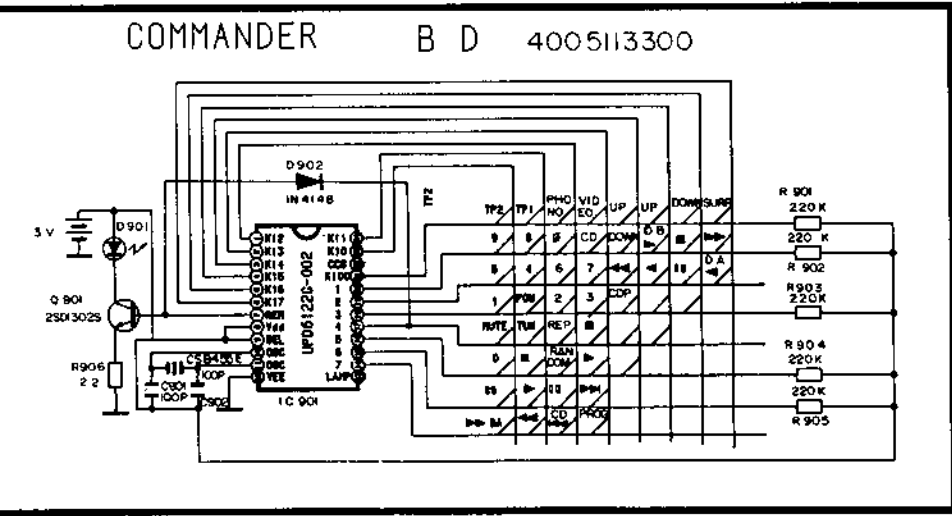
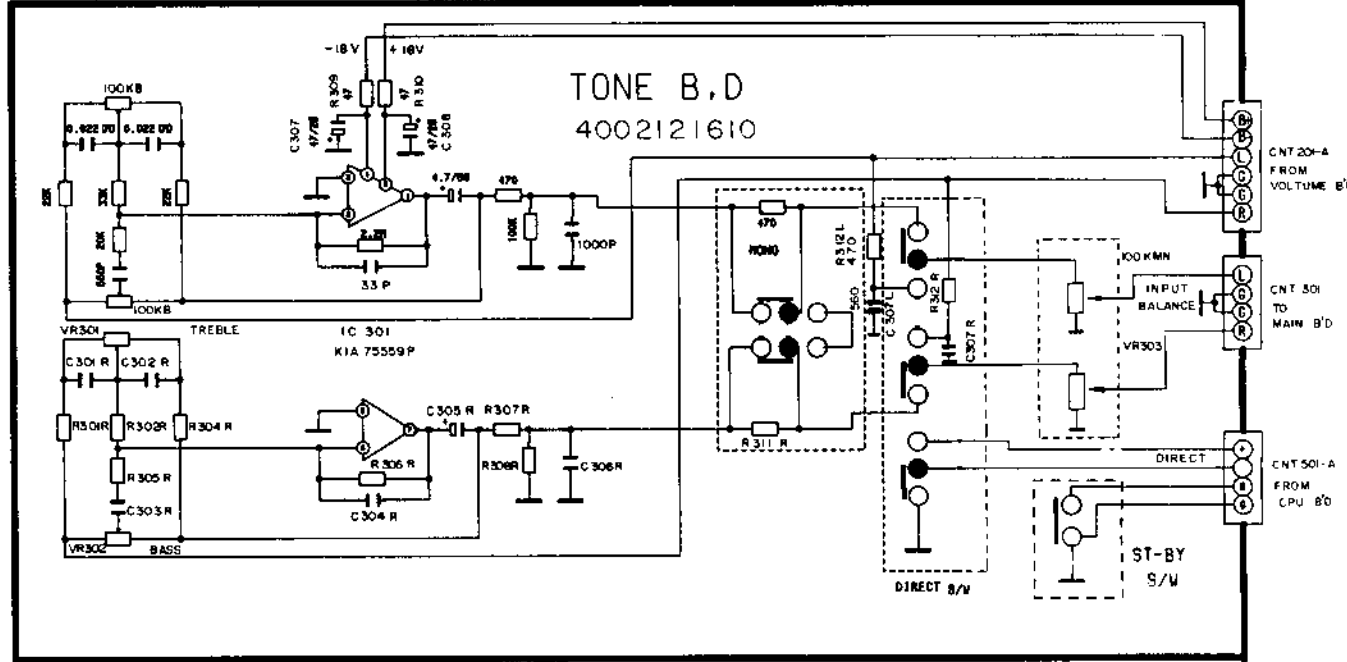
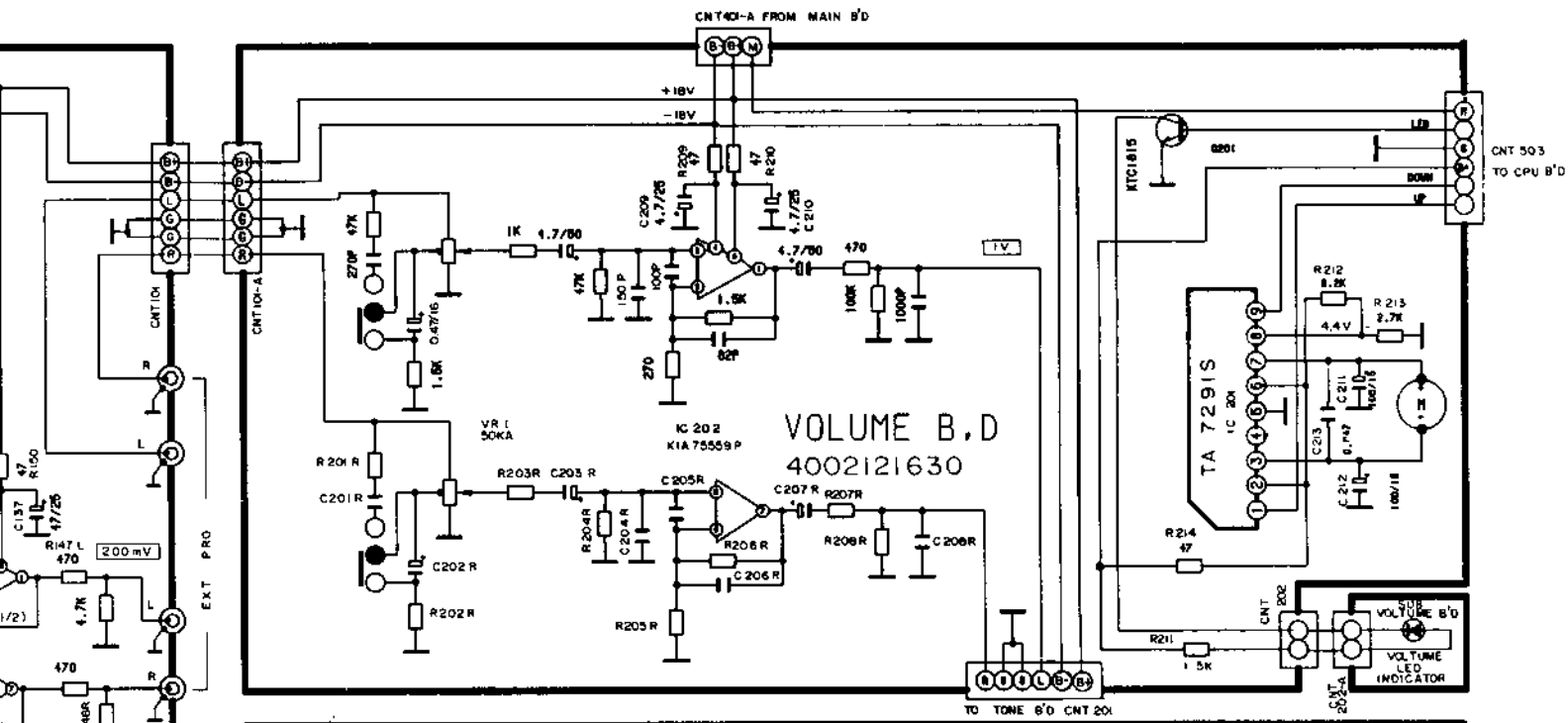

NOTES: 1. Resistance values are indicated in ohms unless otherwise specified (K=1,000 M=1,000,000)
 2. Capacitance values are shown in microfarads unless otherwise noted (P=micro micro farads.)

CAUTION: Safety precautions to be followed during servicing
 1) Since those parts marked with Δ are critical parts for safety use the one described parts list.
 2) Before returning the receiver to the customer make appropriate leakage current or resistance measurements to determine that exposed parts are properly insulated from the supply circuit.

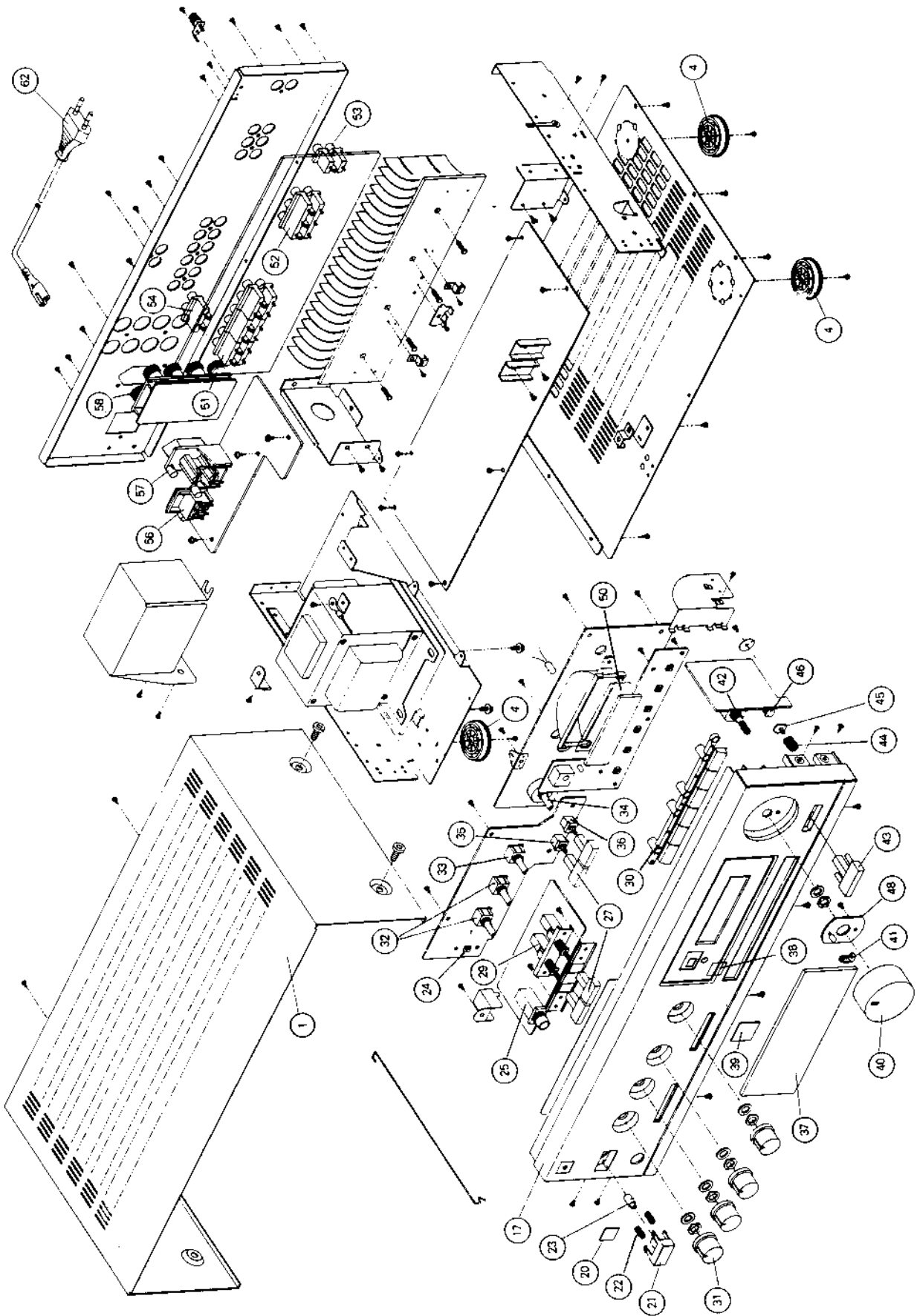

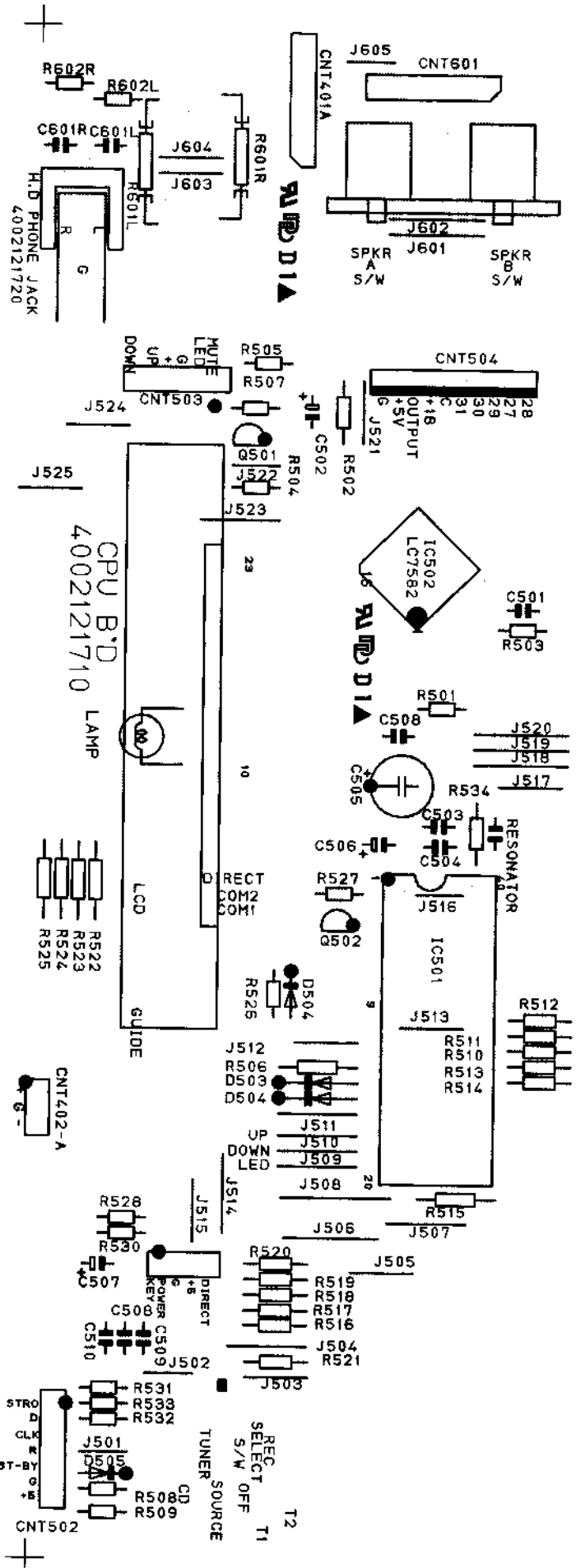
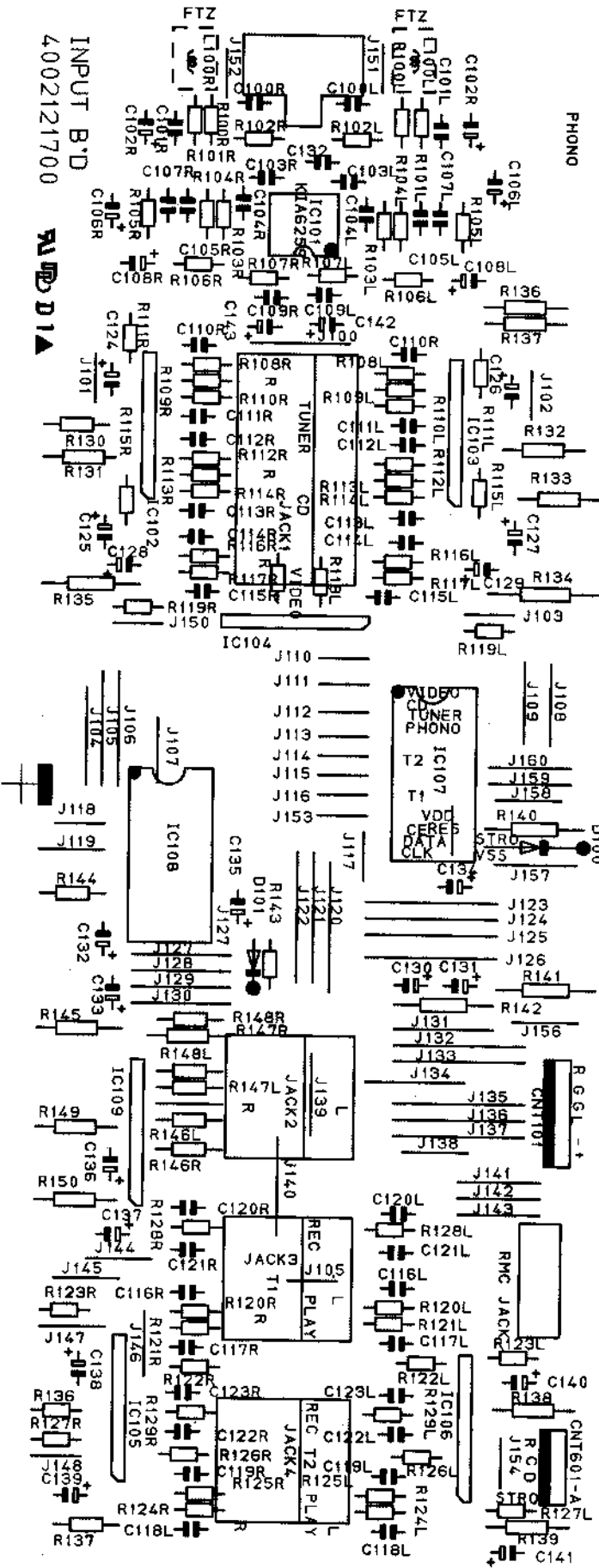

Ersatzteile · Replacement parts · Pièces détachées · CV 650

Pos.	Art.-Nr.	Bezeichnung
1	284 320	Gehäuseblech
4	289 241	Fuß
17	289 243	Frontblende CV 650
20	283 750	DUAL-Zeichen
21	289 244	Taste POWER
22	286 890	Druckfeder
23	289 245	Taste INSERT
24	286 901	Schalter
25	283 705	Kopfhörerbuchse
27	289 246	Taste
29	289 247	Schalter 2-fach
30	289 248	Taste FUNKTION
31	289 249	Knopf
32	284 664	Steller 100 K
33	283 676	Steller
34	289 250	Drehschalter
35	283 675	Schalter
36	283 674	Schalter
37	289 252	Fenster
38	289 253	Dämpfungsfolie
39	289 254	Sensorfenster
40	289 255	Knopf VOLUME
41	289 256	Volume Leuchtstab
42	289 257	Steller mit Motor
43	289 258	Taste LOAD
44	287 459	Feder
45	289 259	Taste INSERT
46	289 260	Schalter
48	289 705	Volume-LED-Platte
49	289 261	Lampe
50	289 262	Dämpfungsfolie
51	283 670	Cinchbuchse
52	289 263	Cinchbuchse 6-fach
53	289 264	Cinchbuchse 2-fach
54	289 265	Cinchbuchse
56	289 266	Netzbuchse
57	289 267	Anschlußbuchse
58	289 269	Lautsprecherklemmen
62	279 596	Netzkabel Europa
C 420	282 070	Grundplatte
C 421	282 070	Elyt-Kond. 6800 UF/63 V
L 401	286 910	Elyt-Kond. 6800 UF/63 V
D 401	282 063	Spule 0,5 UH
D 402	223 906	Diode DZ 12 BM
bis		Diode 1 N 4148
D 404	223 906	Diode 1 N 4148
D 405	226 501	Diode 1 N 4002
D 406	226 501	Diode 1 N 4002
D 407	282 063	Diode DZ 12 BM
D 408	226 501	Diode 1 N 4002
D 409	226 501	Diode 1 N 4002
D 414	282 146	Diode DZ 8,2
D 415	223 906	Diode 1 N 4148
D 416	226 501	Diode 1 N 4002
bis		
D 419	226 501	Diode 1 N 4002
IC 401	287 676	IC GD 7818
IC 402	287 677	IC MC 7918 CT

Pos.	Art.-Nr.	Bezeichnung
Q 401	286 905	Transistor MPS A 56
Q 402	282 077	Transistor KTA 1015 Y
Q 403	282 052	Transistor KTC 2240 BL
Q 404	282 052	Transistor KTC 2240 BL
Q 405	282 076	Transistor KTC 1815 Y
Q 406	282 053	Transistor KTC 2229 Y
Q 407	282 054	Transistor KTA 949 Y
Q 408	286 904	Transistor MPS A 06
Q 409	283 733	Transistor 2 SC 3421
Q 410	283 732	Transistor 2 SA 1358
Q 411	282 055	Transistor 2 SA 1491
Q 412	282 056	Transistor 2 SC 3855
Q 413	286 904	Transistor MPS A 06
Q 414	286 904	Transistor MPS A 06
Q 415	286 905	Transistor MPS A 56
Q 416	286 904	Transistor MPS A 06
bis		
Q 418	286 904	Transistor MPS A 06
Q 419	282 077	Transistor KTA 1015 Y
	289 275	Netztrafo CV 650
		UP-Platte
D 501	289 458	LED SLR 54 URC
D 502	223 906	Diode 1 N 4148
bis		
D 505	223 906	Diode 1 N 4148
IC 501	289 272	IC CPU MC 68 C 05 P
IC 502	283 111	IC LC 7582
	289 270	IR-Empfänger KRM 33
	281 411	Quartz 4 MHz
Q 501	282 076	Transistor KTC 1815 Y
Q 502	282 076	Transistor KTC 1815 Y
		Eingangsplatte
L 101	282 079	Spule 50 UH
D 100	223 906	Diode 1 N 4148
D 101	223 906	Diode 1 N 4148
IC 101	289 271	IC KIA 6259
IC 102	283 707	IC KIA 75559 P
bis		
IC 105	283 707	IC KIA 75559 P
		Tastenplatte
IC 106	286 912	IC LC 7821
IC 107	286 912	IC LC 7821
IC 108	283 707	IC KIA 75559 P
IC 109	283 707	IC KIA 75559 P
D 100	223 906	Diode 1 N 4148
D 101	223 906	Diode 1 N 4148
		VOLUME-Platte
IC 201	287 489	IC TA 7291 S
Q 201	282 076	Transistor KTC 1815 Y
D 801	289 458	LED SLR 54 URC (Volume LED)
		STANDBY-Platte
D 701	226 501	Diode 1 N 4002
bis		
D 705	226 501	Diode 1 N 4002
IC 701	283 727	IC GD 7805
Relais	289 274	Relais
Q 701	286 904	Transistor
	286 909	Trafo STAND BY

Änderungen vorbehalten! Subject to change! Sous réserve de modification!

