

CT 7050











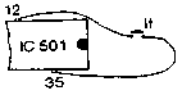
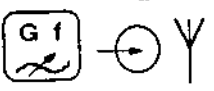







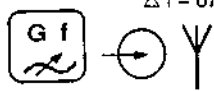

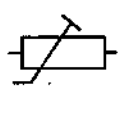





Service-Anleitung Service Manual Instructions de Service

Technische Daten (typische Werte)	Technical data (typical value)	Caractéristiques techniques (valeur caractéristique)	CT 7050
Empfangsbereiche FM (UKW) MW LW	Wave bands FM (VHF) MW LW	Gammes d'ondes FM (C.U.C.) P.O. G.O.	87,5– 108 MHz 520 – 1619 kHz 150 – 283 kHz
Empfindlichkeit FM-Mono (75 Ohm, 26 dB Rauschabstand) FM-Stereo (75 Ohm, 46 dB Rauschabstand)	Sensitivity FM-Mono (75 Ohm, signal-to-noise ratio 26 dB) FM-Stereo (75 Ohm, signal-to-noise ratio 46 dB)	Sensibilité FM-mono (75 ohms, rapport signal/bruit de 26 dB) FM-stéréo (75 ohms, rapport signal/bruit de 46 dB)	0,8 μ V 30 μ V
Geräuschspannungsabstand (IHF) Stereo (1 kHz/46 kHz Hub)	Signal-to-noise ratio, weighted (IHF) Stereo (1 kHz/46 kHz)	Rapport signal/bruit (IHF) Stéréo (1 kHz/46 kHz)	70 dB
Klirrfaktor Stereo (1 kHz/46 kHz Hub)	Harmonic distortion Stereo (1 kHz/46 kHz)	Taux de distorsion Stéréo (1 kHz/46 kHz)	0,20%
Übersprechdämpfung bei 1 kHz	Channel separation at 1,000 Hz	Diaphonie stéréo (à 1 kHz)	45 dB
NF-Frequenzgang für Preemphasis 50 μ s – 3 dB	AF frequency response for 50 μ s pre-emphasis – 3 dB	Bande passante BF pour pré-emphasis 50 μ s à 3 dB	10 Hz – 16 kHz
Trennschärfe	Selectivity	Sélectivité	70 dB
NF-Ausgangsspannung	AF output level	Tension de sortie BF	ca. 500 mV
Netzspannung	Line voltage	Tension secteur	230 V
Leistungsaufnahme	Power requirement	Consommation	19 Watt

	(D) Zeichenerklärung	(GB) Legend	(F) Légende	(E) Leyenda	(I) Leggenda
	Ein	On	Marche	Encendido	Acceso
	Aus	Off	Arrêt	Apagado	Spento
	Ein-Aus	On-Off	Marche-Arrêt	Encendido-Apagado	Acceso-Spento
	Bereitschaft	Stand-by	Attente (veille)	Espera	Disponibile
	Lautstärke	Volume	Volume	Volumen	Volumen
	Balance	Balance	Balance	Balance	Balance
	Höhen	Treble	Aiguës	Agudos	Alti
	Bässe	Bass	Graves	Graves	Bassi
	Lautsprecher	Loudspeaker	Haut-Parleur	Altavoz	Alto parlante
	Kopfhörer	Headphones	Casque	Auriculares	Cuffia
	Hörkapsel	Earphones	Ecouteur	Auricular	Cuffia
	Stummschaltung	Muting	Silencieux	Circuito silencioso	Sintonia Silenziosa
	Abstimmen	Tuning	Syntonisation	Sintonía	Sintonia
	Empfangsfrequenz-Regelung	Automatic frequency control	Contrôle automatique de fréquence	Control automático de frecuencia	Controllo automatico delle frequenza
	Normal-Lauf	Normal-run	Défilement normal	Velocidad normal	Sfilamento normale
	Schnell-Lauf	Fast-run	Défilement rapide	Velocidad rapida	Sfilamento rapido
	Pause	Pause	Pause	Pausa	Pause
	Auswurf	Eject	Ejection	Expulsión	Eiezione
	Stop	Stop	Stop	Stop	Stop
	Stop / Eject	Stop / Eject	Stop / Eject	Stop / Eject	Stop / Eject
	Microphon	Microphone	Microphone	Micrófono	Microfono
	Tonbandgerät	Tape recorder	Magnetophone	Magnetófono	Magnetofono
	Aufnahme	Recording	Enregistrement	Grabación	Registrazione
	Wiedergabe	Play-back	Lecture	Reproducción	Riproduzione
	Antenne	Aerial	Antenne	Antena	Antenne
	Dipole	Dipole	Dipôle	Dipole	Dipole
	Tuner	Tuner	Radio-récepteur	Sintonizador	Tuner
	Plattenspieler	Pick-up	Lecteur de disques	Giradiscos	Giradischi
	Mono	Mono	Mono	Mono	Mono
	Stereo	Stereo	Stereo	Estereo	Stereo
	Uhr, Timer	Clock, Timer	Horloge, minuterie	Reloj, Timer	Orologio, Timer
	Output	Output	Sortie d'un signal	Salida de señales	Uscita di segnale
	Input	Input	Entrée d'un signal	Entrada de señales	Ingresso di segnale
	Trimmer	Trimmer	Trimmer	Trimmer	Trimmer
	Einstellregler	Adjuster	Potentiomètre ajustable	Potenciómetro ajustable	Trimmer ohmico
	Abgleichbarer Kreis	Circuit can be aligned	Circuit à aligner	Circuito ajustable	Circuito a lineare
	L.E.D.	L.E.D.	L.E.D.	L.E.D.	L.E.D.
	Photodiode	Photodiode	Photodiode	Fotodiodo	Photodiodo
	Messpunkt	Test point	Point test	Punto de prueba	Punto di riferimento



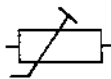

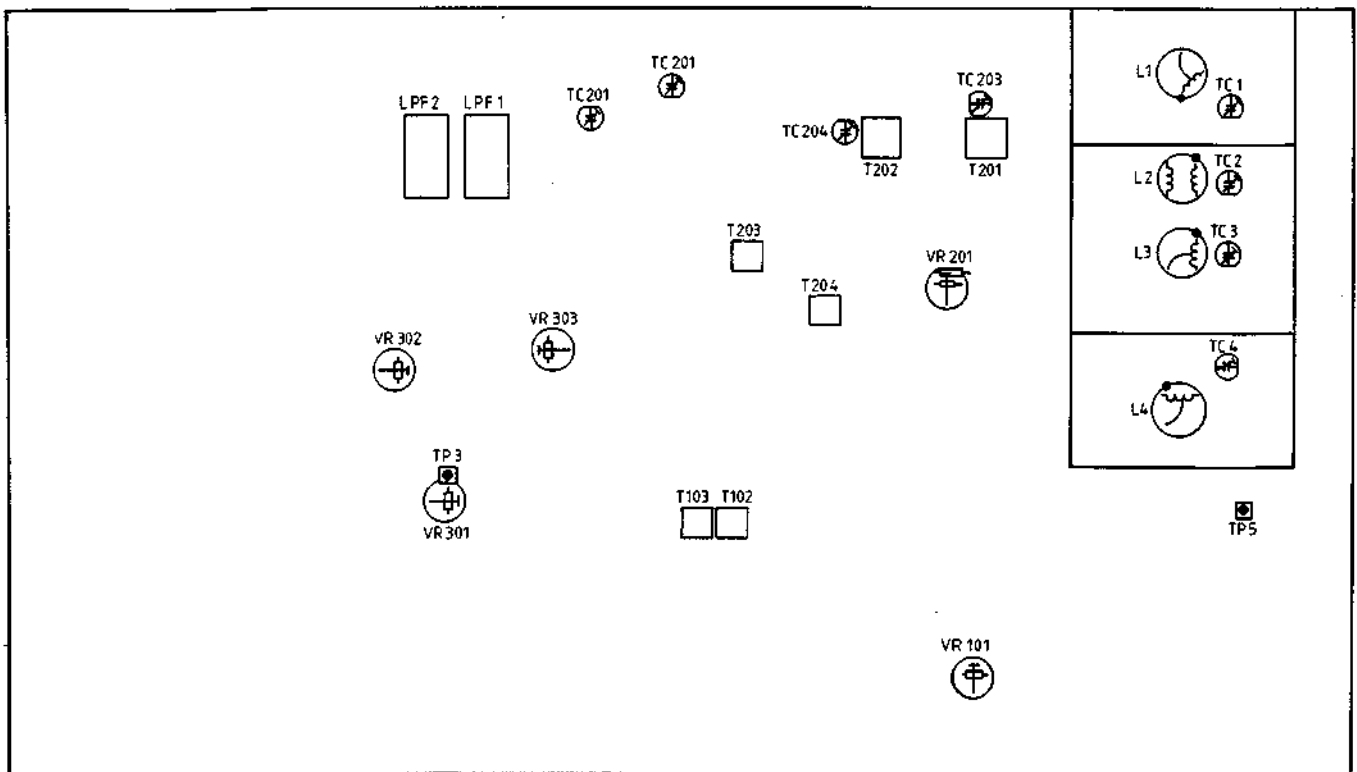
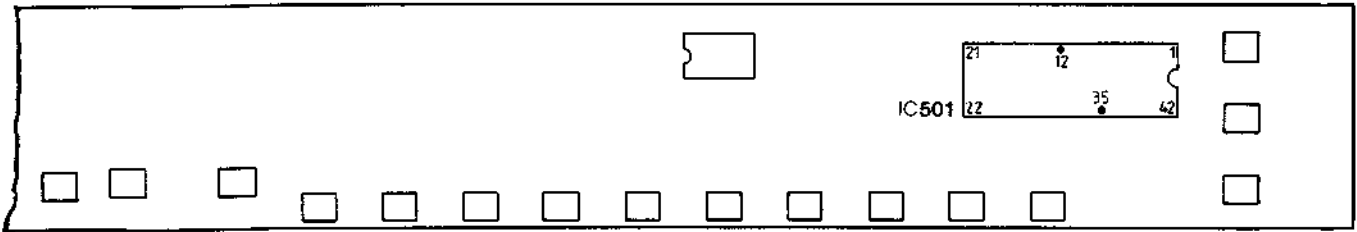

Abgleich / Alignment / Reglages



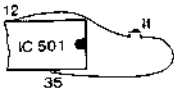
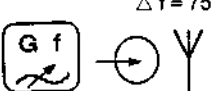

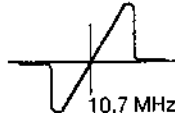
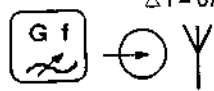
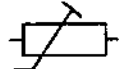

µP nach FM- und AM-Filter justieren (nur bei gelöschtem IC 501) · Adjust µP to FM- and AM filter (only with erased IC 501)						
1	 (kurzschließen 1 s) · Short circuit longer than 1 s					
2	FM-Taste drücken Press FM key	z. B. Keramikfilter „rot“ e.g. Ceramic filter „red“	10,70 MHz	(man. tuning) - +		
3	AM-Taste drücken Press AM key		455 kHz			
4	Netzschalter aus/ein Power switch off/on					
FM						
	$\Delta f = 75 \text{ kHz}$ $f = 1 \text{ kHz}$ 		f			  
ZF	1	 $V_e \sim 1 \text{ mV}$	z. B. Keramikfilter „rot“ e.g. Ceramic filter „red“ 10,70 MHz	Senderfreie Frequenz Transmitting-free frequency z. B. 98 MHz	T 101, T 102, T 103	TP 7  10,7 MHz
IF	2	Antenne an 75 Ohm Antenneneingang Antenna to 75 ohms antenna input		Starken FM-Sender auf seiner Sollfrequenz empfangen tune noise free station to nom. transmitting frequency	T 103	Tuning $\pm 10 \text{ kHz}$ Display muß noch „EXACT“ anzeigen Display has to indicate „EXACT“
FM	3			87,5 MHz	L 4	TP 5 $V = 4 \text{ V} \pm 0,1 \text{ V}$
	4			108 MHz	TC 4	TP 5 $V = 23,5 \text{ V}$
	5	$V_e \sim 1,5 \mu\text{V}$	90 MHz	90 MHz	L1-L2-L3	 max.
	6		106 MHz	106 MHz	TC 1-TC 2-TC 3	
Decoder						
	$\Delta f = 67,5 \text{ kHz}$ $f = 1 \text{ kHz}$ 		f			  
	1	modul. off	98 MHz	98 MHz	VR 301	TP 3 $F = 19 \text{ kHz}$
	2	r. channel modul.	98 MHz	98 MHz	VR 302	l. ch. minimum
	3	l. channel modul.	98 MHz	98 MHz	VR 302	r. ch. minimum
	4	$V_e \approx 1 \text{ mV}$ 19 kHz Pilot ohne Mod. 19 kHz Pilot without mod.	98 MHz	98 MHz	LPF 1	r. ch. minimum
					LPF 2	l. ch. minimum

AM							
		30% mod. 1000 Hz 	f				
ZF IF	1	10 - 100 mV	455 kHz		IFT 203	max.	
	2	455 kHz			IFT 204		
MW	3	$V_e \sim 400 \mu V/m$ 		520 kHz	T 201	V = 1,3 V	TP 5
	4			1619 kHz	TC 203	V = 23,5 V	
	5		600 kHz	600 kHz	(Ferrit Ant.) (Bar Ant.)	max.	
	6		1400 kHz	1400 kHz	TC 201		
LW	7	$V_e \sim 500 \mu V/m$ 		150 kHz	T 202	V = 2,4 V	TP 5
	8			283 kHz	TC 204	V = 12,5 V	
	9		160 kHz	160 kHz	(Ferrit Ant.) (Bar Ant.)	max.	
	10		250 kHz	250 kHz	TC 202		
Mute level tune indicator							
			f			 SIGNAL	
AM	1	$V_e = 500 \mu V/m$	1000 KHz	1000 KHz	VR 201	DISPLAY 74 dB	
FM	2	$V_e = 100 mV$	98 MHz	98 MHz	VR 101	DISPLAY 40 dB	

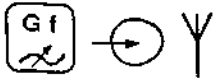

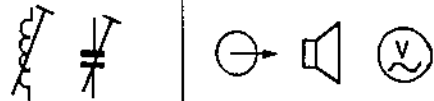
Abgleich / Alignment / Reglages

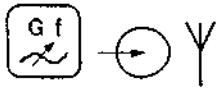
µP nach FM- und AM-Filter justieren (nur bei gelöschtem IC 501) · Adjust µP to FM- and AM filter (only with erased IC 501)						
1	 (kurzschließen 1 s) · Short circuit longer than 1 s					
2	FM-Taste drücken Press FM key	z.B. Keramikfilter „rot“ e.g. Ceramic filter „red“	10,70 MHz	⟨ man. tuning ⟩ - +		
3	AM-Taste drücken Press AM key		455 kHz			
4	Netzschalter aus/ein Power switch off/on					
FM						
	$\Delta f = 75 \text{ kHz}$ $f = 1 \text{ kHz}$ 			 		
ZF	1	 $V_e \sim 1 \text{ mV}$	z.B. Keramikfilter „rot“ e.g. Ceramic filter „red“ 10,70 MHz	Senderfreie Frequenz Transmitting-free frequency z.B. 98 MHz	T 101, T 102, T 103	TP 7  10,7 MHz
	2	Antenne an 75 Ohm Antenneneingang Antenna to 75 ohms antenna input		Starken FM-Sender auf seiner Sollfrequenz empfangen tune noise free station to nom. transmitting frequency	T. 103	Tuning $\pm 10 \text{ kHz}$ Display muß noch „EXACT“ anzeigen Display has to indicate „EXACT“
FM	3			87,5 MHz	L 4	TP 5 $V = 4 \text{ V} \pm 0,1 \text{ V}$
	4			108 MHz	TC 4	TP 5 $V = 23,5 \text{ V}$
	5	$V_e \sim 1,5 \mu\text{V}$	90 MHz	90 MHz	L1-L2-L3	max.
	6		106 MHz	106 MHz	TC 1-TC 2-TC 3	
Decoder						
	$\Delta f = 67,5 \text{ kHz}$ $f = 1 \text{ kHz}$ 					
	1	modul. off	98 MHz	98 MHz	VR 301	TP 3 $F = 19 \text{ kHz}$
	2	r. channel modul.	98 MHz	98 MHz	VR 302	l. ch. minimum
	3	l. channel modul.	98 MHz	98 MHz	VR 302	r. ch. minimum
	4	$V_e \approx 1 \text{ mV}$ 19 kHz Pilot ohne Mod. 19 kHz Pilot without mod.	98 MHz	98 MHz	LPF 1	r. ch. minimum
					LPF 2	l. ch. minimum

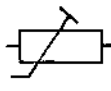
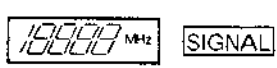
AM							
		30% mod. 1000 Hz 	f				
ZF IF	1	10 - 100 mV	455 kHz	455 kHz	IFT 203	max.	
	2	455 kHz			IFT 204		
MW	3	Ve ~ 400 μV/m 	600 kHz	600 kHz	T 201		V = 1,3 V
	4				TC 203	V = 23,5 V	TP 5
	5				TC 201	max.	
	6						1400 kHz
LW	7	Ve ~ 500 μV/m 	160 kHz	160 kHz	(Ferrit Ant.) (Bar Ant.)	V = 2,4 V	
	8				TC 204	V = 12, 5 V	TP 5
	9				TC 202	max.	
	10						250 kHz
Mute level tune indicator							
			f		 		
AM	1	Ve = 500 μV/m	1000 KHz	1000 KHz	VR 201	DISPLAY 74 dB	
FM	2	Ve = 100 mV	98 MHz	98 MHz	VR 101	DISPLAY 40 dB	

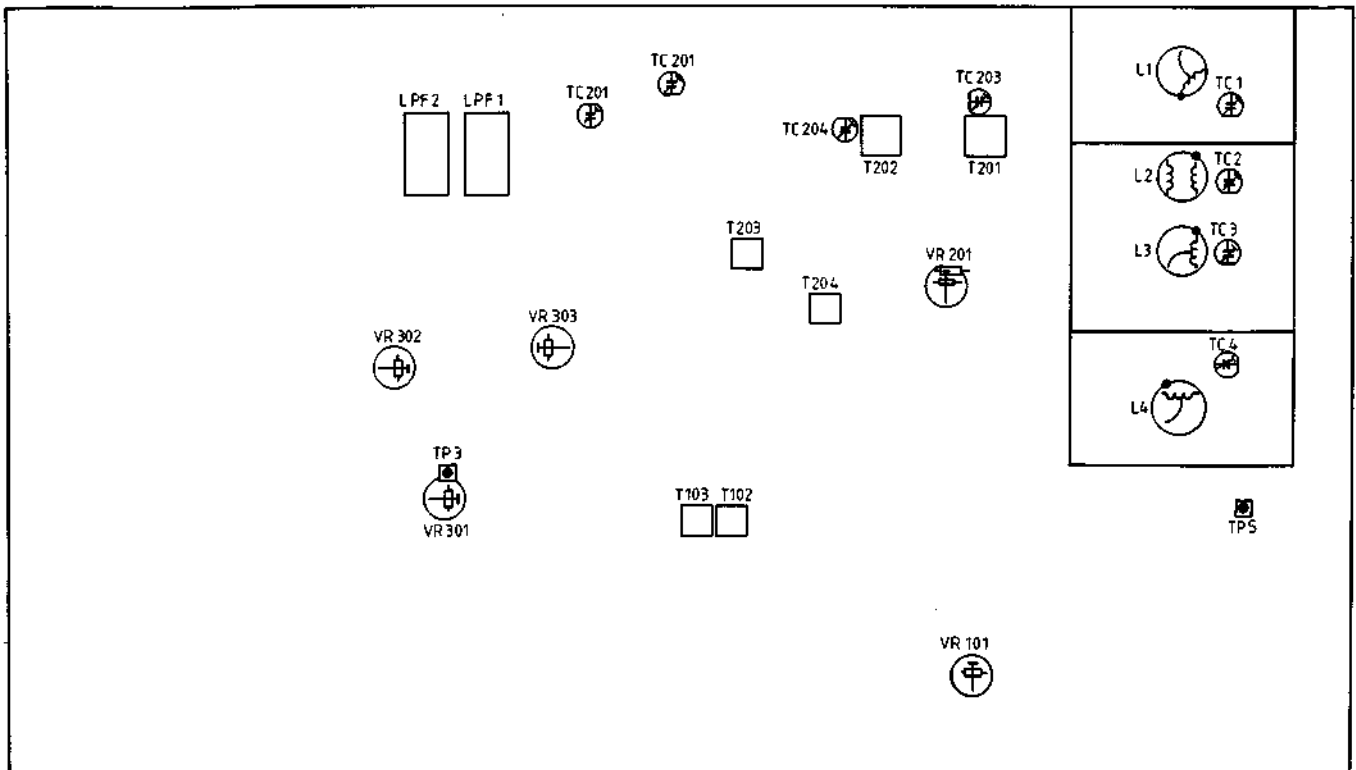
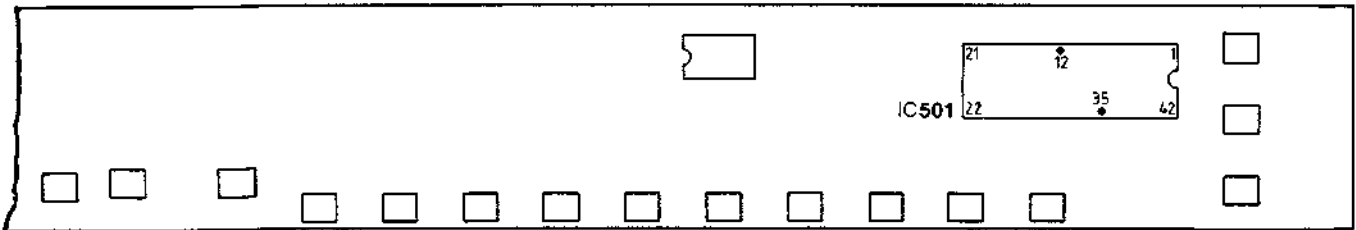

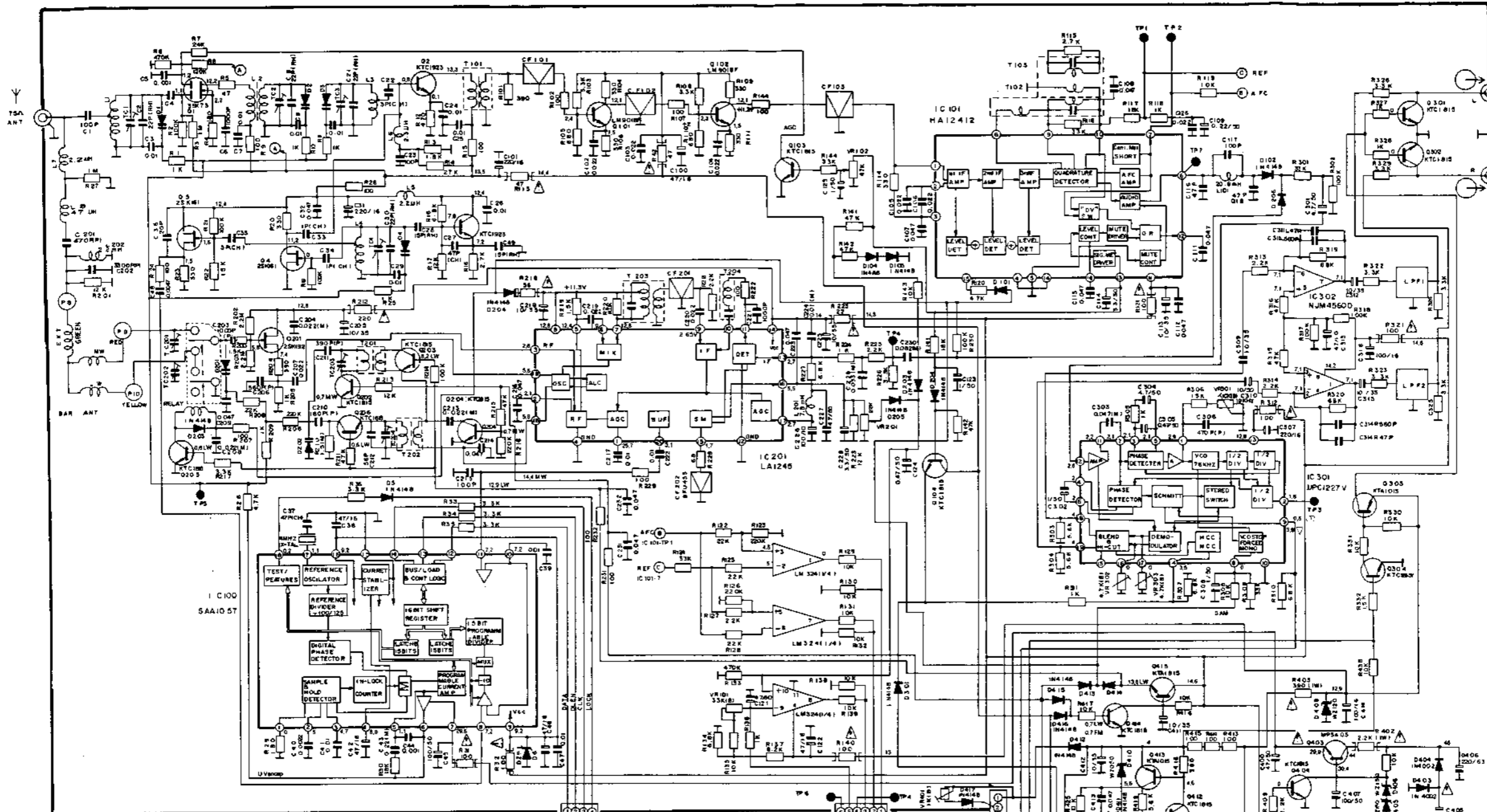

IC 101

	FM	AM
1	2,3	1,7
2	0	0
3	2,3	1,7
4	0	0
5	0	0
6	5,4	6,1
7	5,2	5,7
8	5,6	5,7
9	5,6	5,7
10	5,7	5,7
11	11,9	12,3
12	1,9	4,9
13	3,9	0,2
14	0	0
15	0	8,4
16	5,7	0

Keramikfilter	Frequenz
Black	10,64 MHz
Blue	10,67 MHz
Red	10,70 MHz
Orange	10,73 MHz
White	10,76 MHz

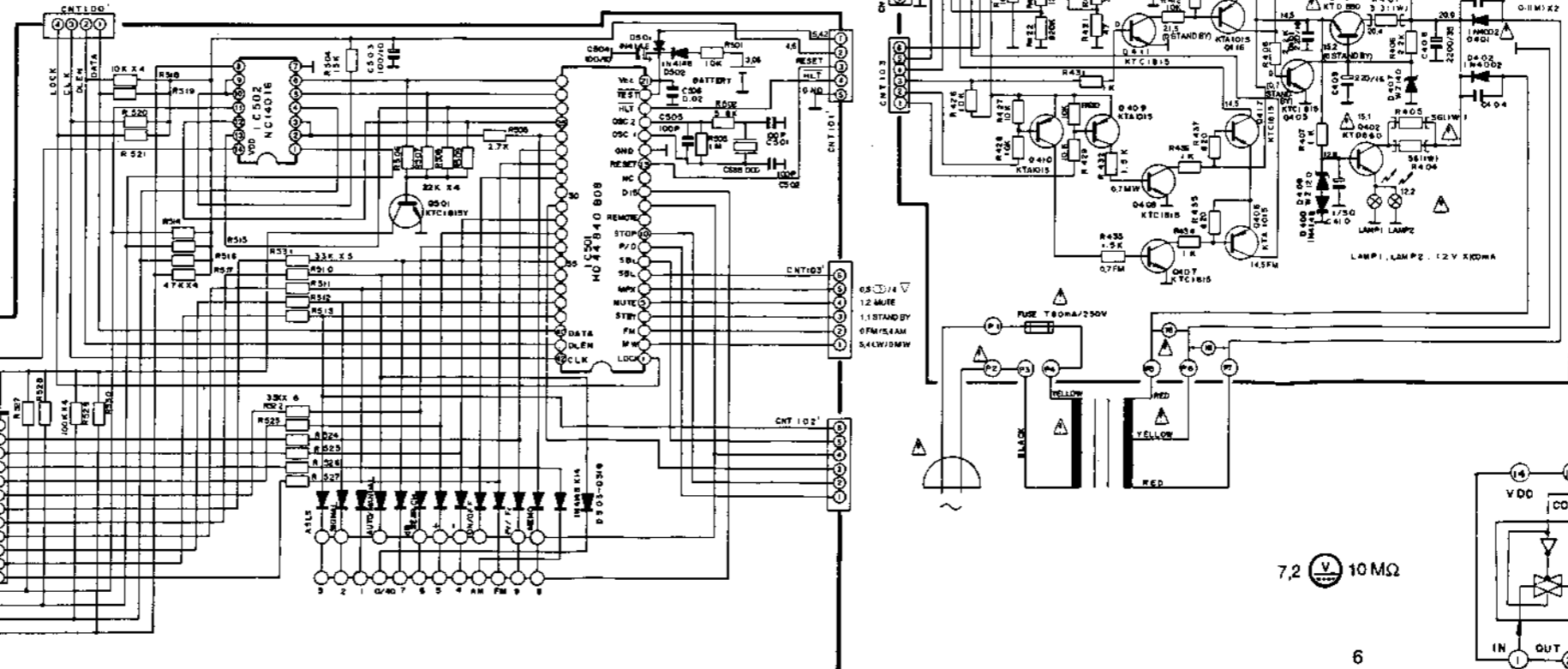
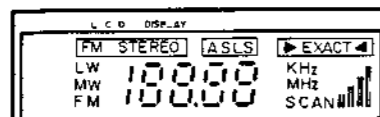

MC 14016 B

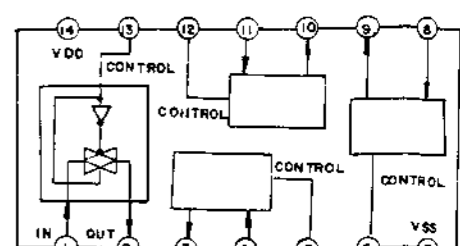

7,2 V 10 MΩ

Frontplatte
PCB controls / fréquence display
Platine afficheur / commandes

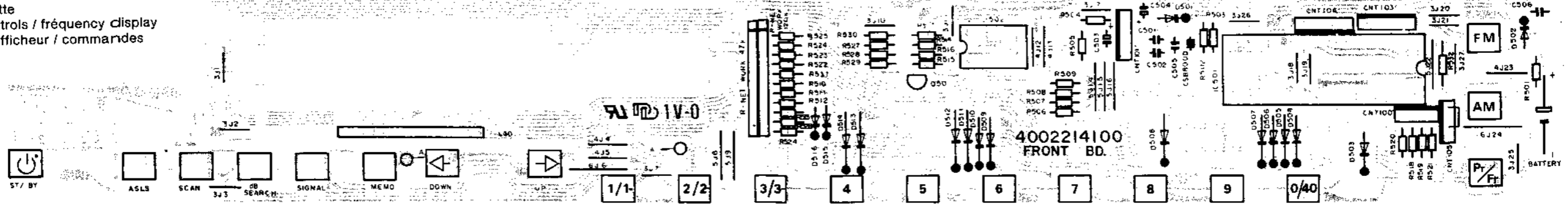

Grundplatte
Main board
Platine principale

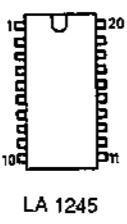
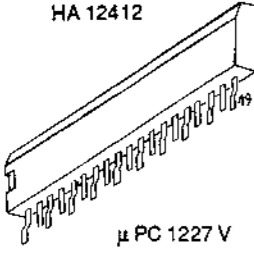
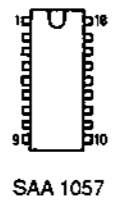
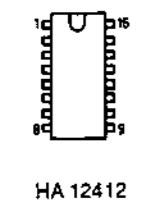
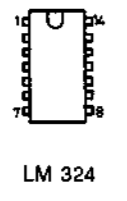
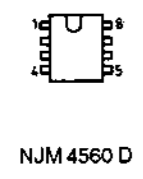
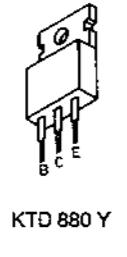
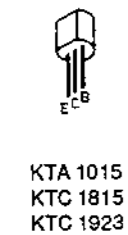
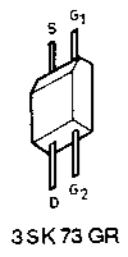
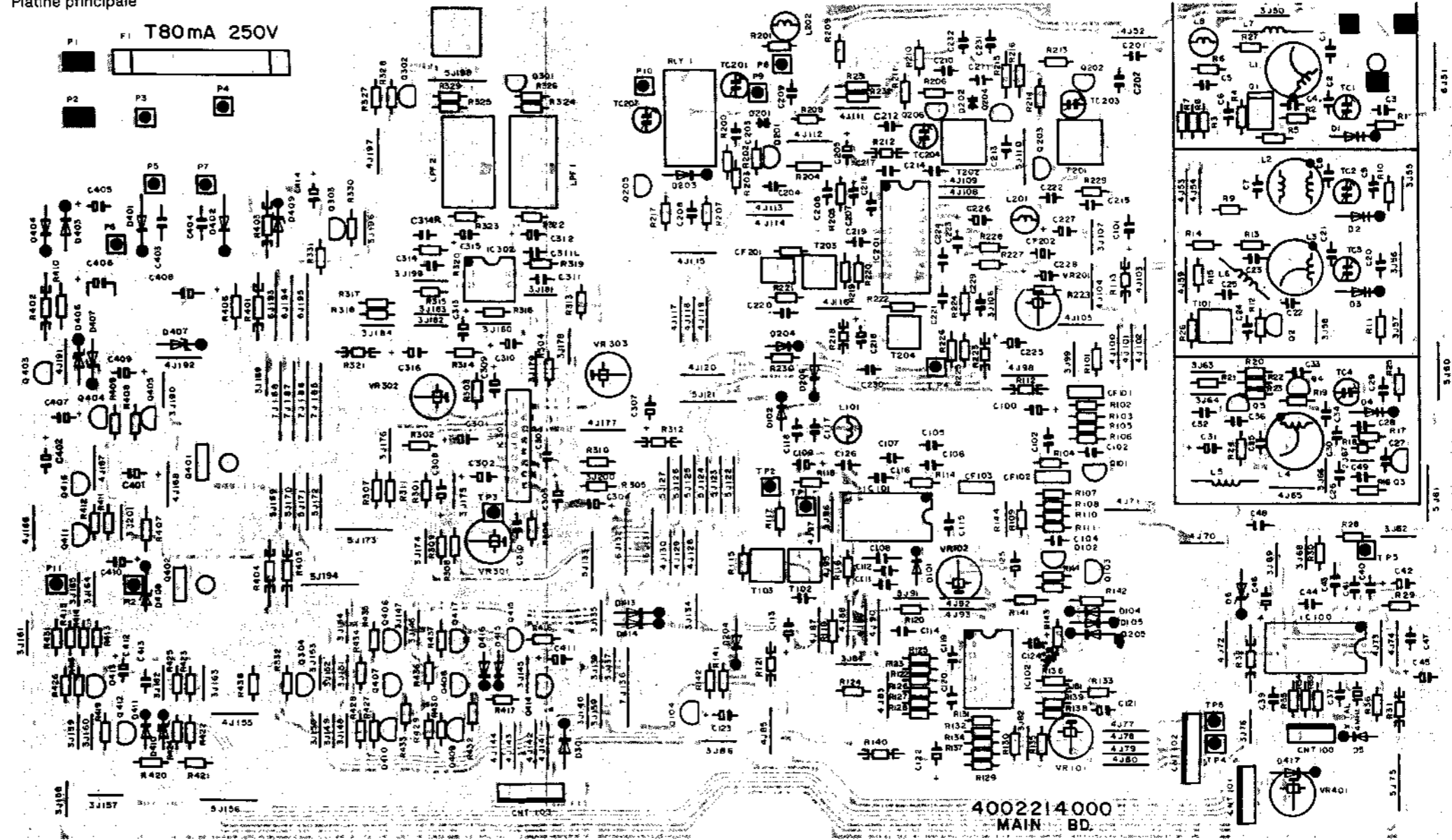

Bestückungsseite
Component side
Côté composants

Ersatzteile · Replacement parts · Pièces détachées · CT 7050

Pos.	Art.-Nr.	Stck	Bezeichnung
1	282 331	1	Gehäuseblech
2	282 332	1	Frontblende
3	282 333	1	Seitentail R
4	282 334	1	Seitentail L
5	282 335	1	Blendenträger
6	282 336	1	Fenster
7	282 108	1	Druckknopf power
8	282 109	1	Druckfeder
9	282 337	1	Taste ASLS – Memory
10	282 338	1	Taste Man. Tuning / Auto Scan
11	282 339	1	Taste Station 1–5
11	282 340	1	Taste Station 6–0
13	282 341	1	Taste FM Stations
14	282 342	1	Taste AM Stations
15	282 343	1	Taste Program Frequency
16	282 208	1	Display
20	282 344	2	Lampe
23	282 345	1	Taster Power
24	282 127	20	Taster
27	282 346	1	Antennenbuchse
28	282 347	1	Cinchbuchse 1-fach
42	282 120	4	Fuß
43	282 121	4	Fußdämpfer
45	282 348	1	Rückwand
46	243 750	1	Netzkabel Europa
48	282 349	1	Antennenhalter
49	282 350	1	MW / LW Antenne
51	282 135	4	Schraube 14 × 8
55	282 523	12	Schraube 3 × 8
62	282 216	1	Transformator
63	282 165	1	Grundplatte
64	282 205	1	Frontplatte
65	282 352	1	Lampenplatte
D 1	275 858	4	Diode 1 SV 68
D 4	275 858	4	Diode 1 SV 68
D 6	282 062	1	Diode DZ 9,1 BM
D 101	223 906	17	Diode 1 N 4148
D 102	223 906	17	Diode 1 N 4148
D 104	223 906	17	Diode 1 N 4148
D 105	223 906	17	Diode 1 N 4148
D 106	223 906	17	Diode 1 N 4148
D 201	268 704	2	Diode KV 1226
D 202	268 704	2	Diode KV 1226
D 203	223 906	17	Diode 1 N 4148
D 206	223 906	17	Diode 1 N 4148
D 301	223 906	17	Diode 1 N 4148
D 400	223 906	17	Diode 1 N 4148
D 401	226 501	4	Diode 1 N 4002
D 404	226 501	4	Diode 1 N 4002
D 405	282 173	3	Diode DZ 15 B
D 406	282 173	3	Diode DZ 15 B
D 407	282 173	3	Diode DZ 15 B
D 409	282 063	1	Diode DZ 12 BM
D 410	282 174	1	Diode DZ 5,1 BM
D 411	223 906	17	Diode 1 N 4148
D 413	223 906	17	Diode 1 N 4148
D 417	223 906	17	Diode 1 N 4148
D 501	223 906	16	Diode 1 N 4148
D 516	223 906	16	Diode 1 N 4148
L 1	282 179	1	Spule
L 2	282 180	1	Spule
L 3	282 181	1	Spule
L 4	282 182	1	Spule
L 5	282 191	3	Spule 2,2 UH
L 6	282 191	3	Spule 2,2 UH
L 7	282 191	3	Spule 2,2 UH
L 8	282 192	1	Spule 47 UH
L 101	282 194	1	Spule 20,8 UH
L 201	282 193	1	Spule 7,8 UH
L 202	282 195	1	Spule 2,2 MH
L 9999	282 206	1	Quarz CS B 800 D
Q 1	282 168	1	Transistor 3 SK 73 GR
Q 2	282 171	2	Transistor KTC 1923 Y
Q 3	282 171	2	Transistor KTC 1923 Y

Pos.	Art.-Nr.	Stck	Bezeichnung
Q 4	282 169	2	Transistor KTK 161 Y
Q 5	282 169	2	Transistor KTK 161 Y
Q 101	282 172	2	Transistor LM 9018 F
Q 102	282 172	2	Transistor LM 9018 F
Q 103	282 076	18	Transistor KTC 1815 Y
Q 104	282 076	18	Transistor KTC 1815 Y
Q 201	282 170	1	Transistor 2 SK 192 GR
Q 202	282 076	18	Transistor KTC 1815 Y
Q 206	282 076	18	Transistor KTC 1815 Y
Q 301	282 076	18	Transistor KTC 1815 Y
Q 302	282 076	18	Transistor KTC 1815 Y
Q 303	282 077	7	Transistor KTA 1015 Y
Q 304	282 076	18	Transistor KTC 1815 Y
Q 401	282 057	2	Transistor KTD 880 Y
Q 402	282 057	2	Transistor KTD 880 Y
Q 403	282 059	1	Transistor MPS A05
Q 404	282 076	18	Transistor KTC 1815 Y
Q 405	282 076	18	Transistor KTC 1815 Y
Q 406	282 077	7	Transistor KTA 1015 Y
Q 407	282 076	18	Transistor KTC 1815 Y
Q 409	282 077	7	Transistor KTA 1015 Y
Q 410	282 077	7	Transistor KTA 1015 Y
Q 411	282 076	18	Transistor KTC 1815 Y
Q 412	282 076	18	Transistor KTC 1815 Y
Q 413	282 077	7	Transistor KTA 1015 Y
Q 414	282 076	18	Transistor KTC 1815 Y
Q 415	282 076	18	Transistor KTC 1815 Y
Q 416	282 077	7	Transistor KTA 1015 Y
Q 417	282 077	7	Transistor KTA 1015 Y
Q 428	282 076	18	Transistor KTC 1815 Y
Q 501	282 076	1	Transistor KTC 1815 Y
R 1	282 214	1	Netzwerk 11 × 473 G
R 2	282 213	1	Netzwerk 11 × 124 G
T 101	282 393	1	Spule
T 102	282 183	1	Spule
T 103	282 184	1	Spule
T 201	282 186	1	Spule
T 202	282 187	1	Spule
T 203	282 189	1	Spule
T 204	282 188	1	Spule
BA 1	282 207	1	Akku CR 2439-8
CF 101	282 196	3	Keramikfilter SFZ 10,7 M2
CF 102	282 196	3	Keramikfilter SFZ 10,7 M2
CF 103	282 196	3	Keramikfilter SFZ 10,7 M2
CF 201	282 198	1	Keramikfilter SFP 455
CF 202	282 197	1	Keramikfilter BFU 455
CR 1	282 175	1	Quarz 4 MHz
IC 100	274 730	1	IC SAA 1057
IC 101	268 204	1	IC HA 12412
IC 102	261 352	1	IC LM 324
IC 201	282 167	1	IC LA 1245
IC 301	282 166	1	IC UPC 1227
IC 302	274 480	1	IC NJM 4560 DX
IC 501	281 970	1	IC UP HD 44840 / B 08
IC 502	261 874	1	IC MC 14016 BCP MOS
LD 1	282 208	1	Display
LF 1	282 190	2	Spule MPX
LF 2	282 190	2	Spule MPX
RY 1	282 176	1	Relay RZ 12
TC 1	282 177	4	Trimmer TZ 03 7110 F
TC 4	282 177	4	Trimmer TZ 03 7110 F
TC 201	282 178	2	Trimmer TZ 03 R 200 F
TC 202	282 178	2	Trimmer TZ 03 R 200 F
VR 101	282 202	1	Steller 33 kΩ
VR 102	282 203	1	Steller 47 kΩ
VR 201	282 201	1	Steller 22 kΩ
VR 301	282 200	1	Steller 10 kΩ
VR 302	282 199	2	Steller 4,7 kΩ
VR 303	282 199	2	Steller 4,7 kΩ
VR 401	282 204	1	Steller 1 kΩ
9000	281 430	1	Bedienungs-Anleitung CT 7050
9001	282 526	1	Verpackung kpl. CT 7050

Änderungen vorbehalten! Subject to change! Sous réserve de modification!