

AKAI SERVICE MANUAL

FM/MW/LW STEREO TUNER

MODEL AT-K110L

* This manual must be used as a set together with separately published AT-K110 service manual.

I. SPECIFICATIONS

FM TUNER SECTION

TUNING FREQUENCY RANGE	87.5 to 108.0 MHz
SENSITIVITY USABLE (S/N = 30dB)	12.7 dBf (Mono)/27.2 dBf (Stereo)
QUIETING (S/N = 50 dB)	19.2 dBf (Mono)/40.2 dBf (Stereo)
CAPTURE RATIO	2.0 dB
SELECTIVITY (± 400 kHz)	60 dB
IMAGE REJECTION	50 dB
IF REJECTION	80 dB
SPURIOUS REJECTION	80 dB
AM SUPPRESSION	50 dB
SUB CARRIER SUPPRESSION	55 dB
S/N (MONO/STEREO)	70/62 dB
T.H.D. (MONO/STEREO)	0.3/0.4% (\pm kHz deviation)
STEREO SEPARATION	38 dB
MUTING THRESHOLD LEVEL	22 dB
ANTENNA INPUT IMPEDANCE	300 ohms

MW TUNER SECTION

TUNING FREQUENCY RANGE	525 to 1,605 kHz
USABLE SENSITIVITY (IHF)	
LOOP ANTENNA	300 μ V/m
SELECTIVITY	35 dB
IMAGE REJECTION	45 dB
IF REJECTION	35 dB
S/N	40 dB
T.H.D.	1.0%

LW TUNER SECTION

TUNING FREQUENCY RANGE	145 to 360 kHz
USABLE SENSITIVITY (IHF)	
LOOP ANTENNA	1,000 μ V/m
SELECTIVITY	32 dB
IMAGE REJECTION	45 dB
IF REJECTION	25 dB
S/N	30 dB
T.H.D.	3.0%

OUTPUT SECTION

OUTPUT VOLTAGE	
FM (100% MODULATION)	550 mV
POWER REQUIREMENTS	220V, 50 Hz for Europe except UK 240V, 50 Hz for UK
DIMENSIONS	440 (W) \times 80 (H) \times 246 (D) mm (17.3 \times 3.1 \times 9.7) inches
WEIGHT	2.9 kg (6.4 lbs)
POWER CONSUMPTION	6W

* For improvement purposes, specifications and design are subject to change without notice.
* This manual is applicable to both silver and pearl shadow panel model.

II. TUNER ADJUSTMENT

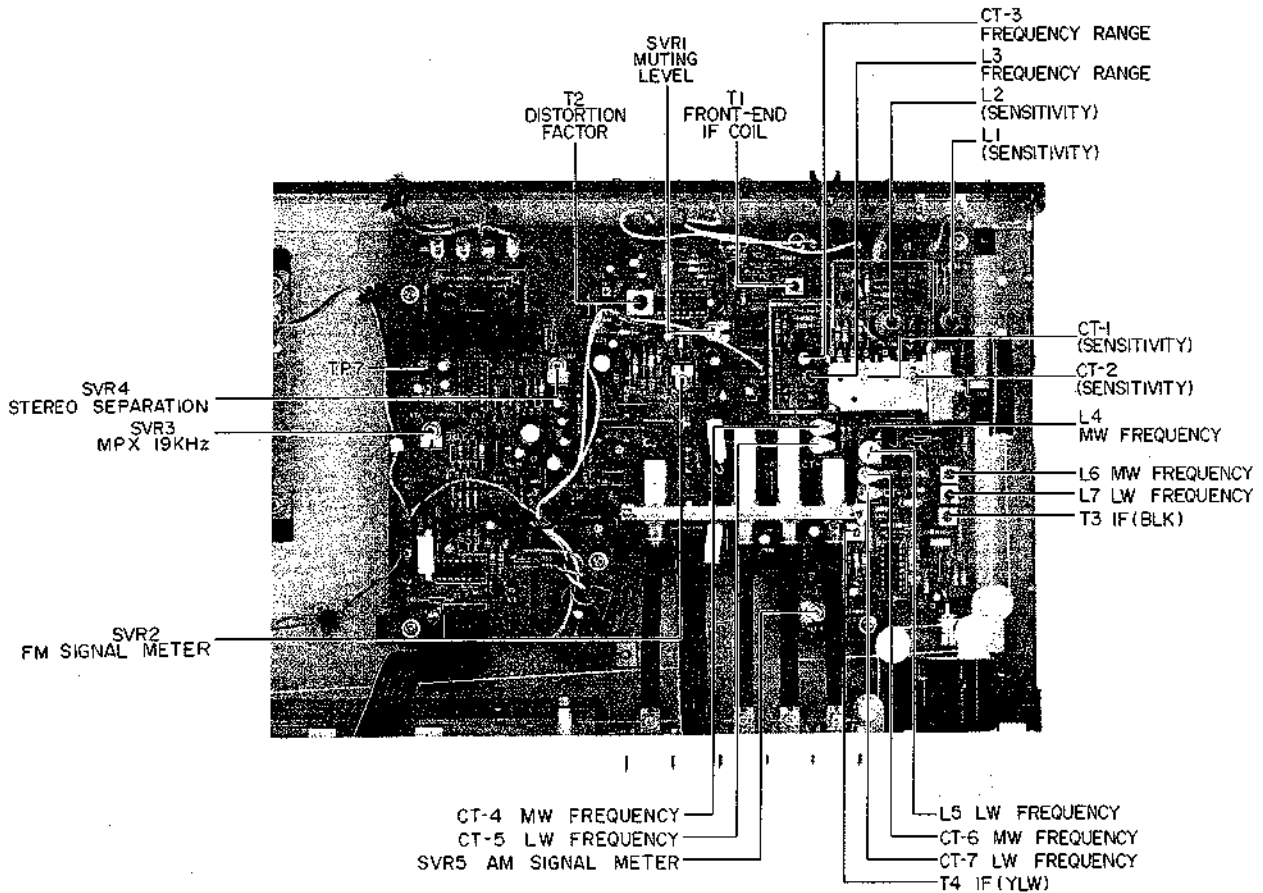

Step	Adjustment Item	S.S.G.		Dial Pointer Position	Adjustment Point	Result & Remarks
		Frequency	A.T.T.			
1	IF	468 kHz	74 dB	Lower End	T3 (BLK) T4 (YLW)	Maximum Output Level.
2	MW Frequency Range	515 kHz	64 dB	Lower End	L6 L4	Maximum Output Level.
3		1,650 kHz	64 dB	Upper End	CT6 CT4	Maximum Output Level.
4		600 kHz	54 dB	600 kHz	L4 CT4	Maximum Output Level.
5		1,400 kHz	54 dB	1,400 kHz		
6		LW Sensitivity	145 kHz	74 dB	Lower End	L7 L5
7	365 kHz		74 dB	Upper End	CT7 CT5	Maximum Output Level.
8	150 kHz		64 dB	150 kHz	L5 CT5	Maximum Output Level.
9	350 kHz		64 dB	350 kHz		
10	AM Signal Meter	1,000 kHz	94 dB	1,000 kHz	SVR5	Three LEDs of SIGNAL LED light up.

NOTE: Be sure to proceed the AM SIGNAL METER Adjustment prior to FM SIGNAL METER Adjustment.

Step	Adjustment Item	S.S.G.		Dial Pointer Position	Adjustment Point	Result & Remarks
		Frequency	A.T.T.			
1	Front-end IF Coil	No Signal		98 MHz	T1	Maximum Output Level.
2	Distortion Factor	98 MHz	70 dB	98 MHz	T2	Less than 0.3% in both channels.
3	Frequency Range	87.3 MHz	50 dB	Lower End	L3	Maximum Output Level
		108.3 MHz	50 dB	Upper End	CT3	
4	Sensitivity	90 MHz	15 dB	90 MHz	L1, L2	Maximum Output Level.
		106 MHz	15 dB	106 MHz	CT1, CT2	
5	Signal Meter	98 MHz	20 dB	98 MHz	SVR2	First LED of SIGNAL LED lights up.
6	Muting Level	98 MHz	20 dB	98 MHz	SVR1	Mute Switch to ON.
7	MPX				SVR3	FM AUTO Switch to ON. 19 kHz
8	Stereo Separation	98 MHz	50 MHz	98 MHz	SVR4	FM AUTO Switch to ON. Optimum Lch and Rch Separation.

2. COMPOSITION OF VARIOUS P.C BOARDS

Tuner P.C Board R-4174059-4, Power Supply P.C Board R-4174058, AFC P.C Board R-4173620, Function Ind. P.C Board R-474059-2, LED P.C Board R-474059-3 and Pointer P.C Board.

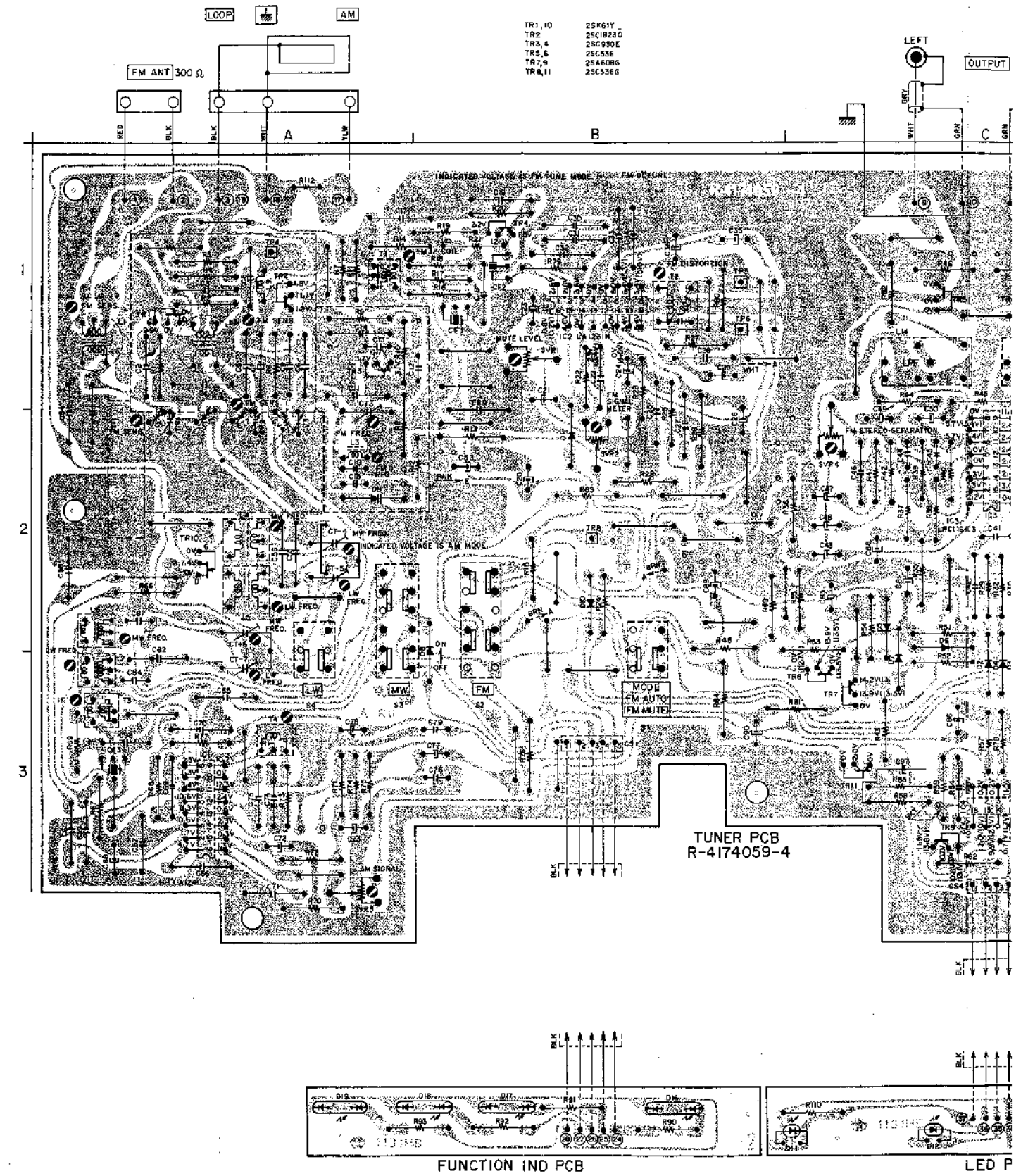

III. CLASSIFICATION OF VARIOUS P.C BOARDS

1. P.C BOARD TITLES AND IDENTIFICATION NUMBERS

P.C Board	Number of P.C Board
Power Supply P.C Board	R-4174058
Function IND P.C Board	R-4174059-2
LED P.C Board	R-4174059-3
Tuner P.C Board	R-4174059-4
AFC P.C Board	R-4173620
Pointer P.C Board	

2. COMPOSITION OF VARIOUS P.C BOARDS

Tuner P.C Board R-4174059-4, Power Supply P.C Board R-4174058, AFC P.C Board R-4173620, Function Ind. P.C Board R-474059-2, LED P.C Board R-474059-3 and Pointer P.C Board.

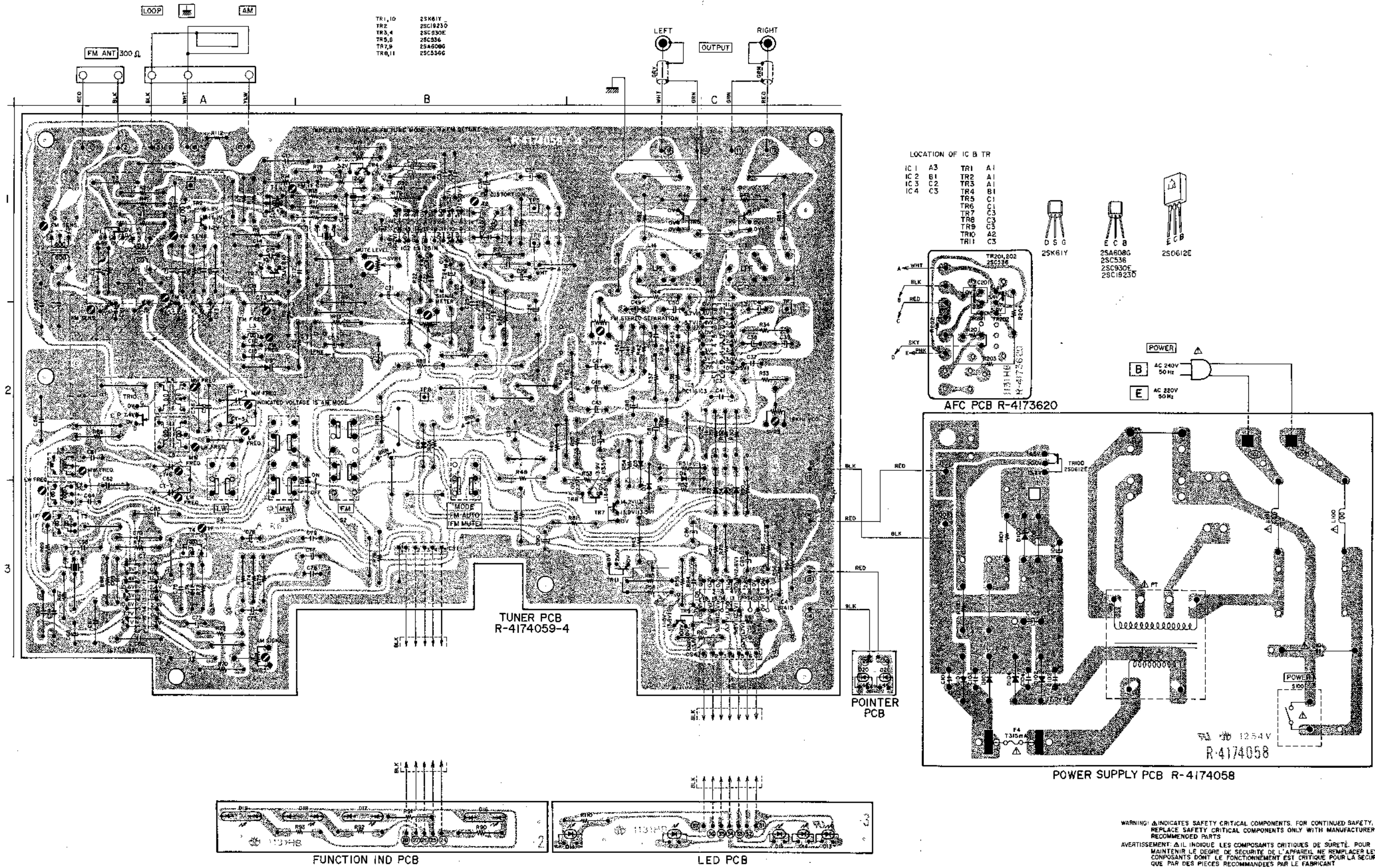

IV. PARTS LIST

* Following parts were newly supplied for model AT-K110L.

REF. NO.	PARTS NO.	DESCRIPTION
1	BA-707988	PC TUNER BLK AT-K110L
2	EO-707990	COIL TUN (L5)
3	EO-707991	COIL OSC 2 (L7)
4	EC-707992	C S-FIX (CT3)
5	EC-707993	C S-FIX (CT4-7)
6	EC-334411	C STY V F05 500 131J 50 DC (C64)
7	BT-709858	Δ TRANS POWER AT-K110L B
8	SP-707983	PANEL FRONT AT-K110L
9	SP-707985	PANEL FRONT (P) AT-K110L-P
10	TA-707986	LEVER KNOB POWER
11	EJ-707987	TERMINAL SCREW 2P

* Following parts for model AT-K110 cannot be used for model AT-K110L.

2. TUNER P.C BOARD BLOCK

2-1	BA-707216	PC TUNER BLK AT-K110 (U)
2-2	BA-707650	PC TUNER BLK AT-K110 (C)
2-3	BA-707651	PC TUNER BLK AT-K110 (A)
2-4	BA-707652	PC TUNER BLK AT-K110 (E)
2-5	BA-707653	PC TUNER BLK AT-K110 (S)
2-6	BA-707654	PC TUNER BLK AT-K110 (V)
2-D10	ED-562386	D GERM H JS188AM (U)
2-L10	EO-707226	COIL FIX (U)
2-L15	EO-707662	COIL FIX (V)
2-L16	EO-707663	COIL FIX (V)
2-CT3	ER-707232	CS-FIX
2-CT4	ER-707232	CS-FIX
2-CT6	EO-707232	CS-FIX
2-SVR5	EO-707238	R S-FIX203
2-C37	EC-672287	CSTY V 511J 50.0 DC (U)
2-C63	EC-304849	CSTY V 361J 50 DC (U)

3. POWER SUPPLY P.C BOARD BLOCK

3-S100	ES-706306	Δ SW PUSH (C, A)
3-L100, 101	EO-707661	COIL FIX (V)
3-R100	ER-341940	R OMF H SNP FS 1W 100J(U)
3-C100	EC-707250	Δ C CE 103 250AC (U)
3-C100	EC-706422	Δ C CE 103 250AC (C, A)
3-C105	EC-316188	CECV CUT SM102 25DC (U)

4. ASSEMBLY BLOCK

4-5	TA-707202	LEVER KNOB POWER
4-14	EW-707212	Δ AC CORD (U)
4-15x	EW-706647	Δ AC CORD (C, A)
4-20	ZS-707648	TERMINAL SCREW 2P (C, A)
4-22x	ZS-707649	TERMINAL SCREW 3P (C, A)
4-24	BT-707246	Δ TRANS POWER AT-K110 (U)
4-25x	BT-707655	Δ TRANS POWER AT-K110 (C)
4-26x	BT-707656	Δ TRANS POWER AT-K110 (A)
4-28x	BT-707659	Δ TRANS POWER AT-K110 (S)

V. SCHEMATIC DIAGRAM

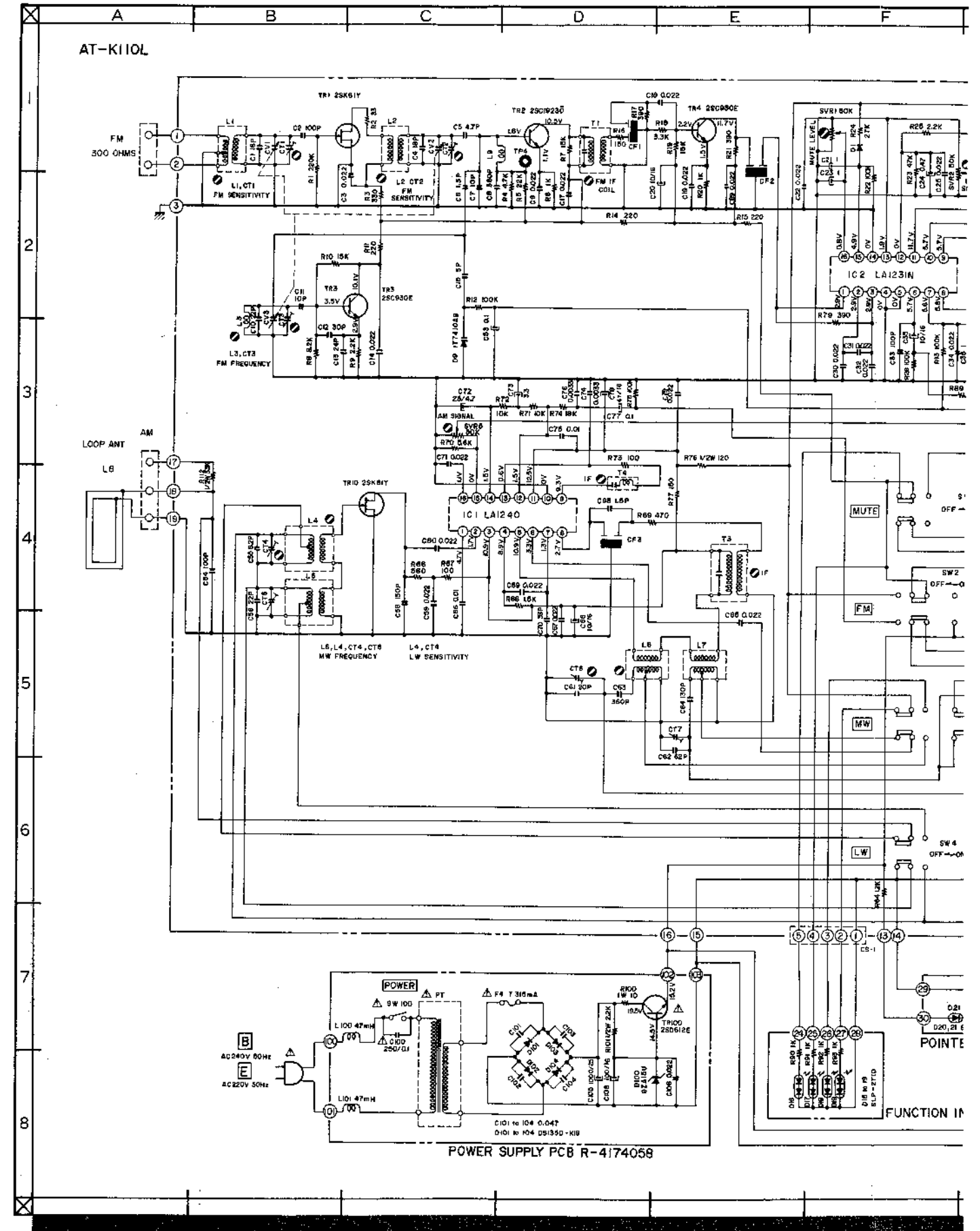

V. SCHEMATIC DIAGRAM

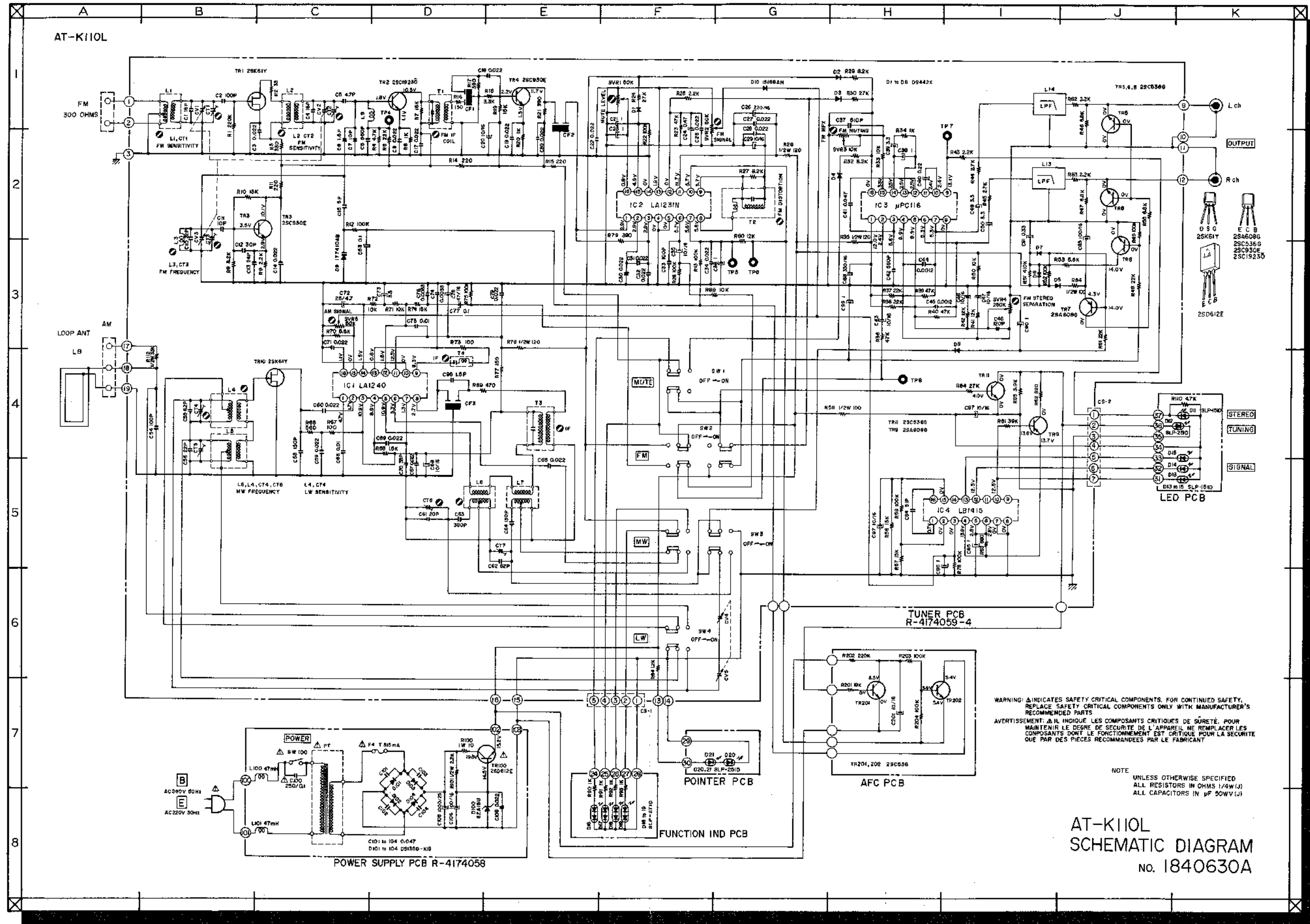

AT-K110L

AT-K110
AM-U110

AKAI SERVICE MANUAL

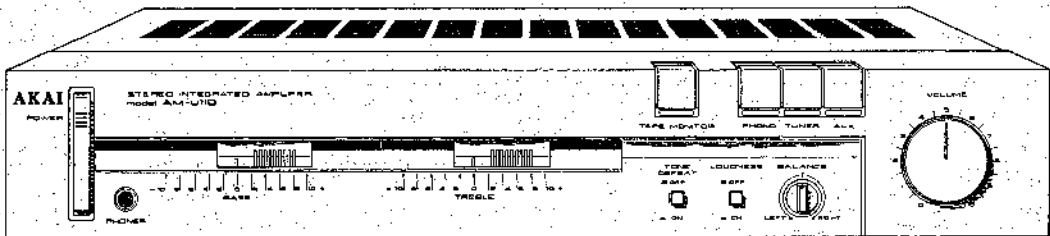
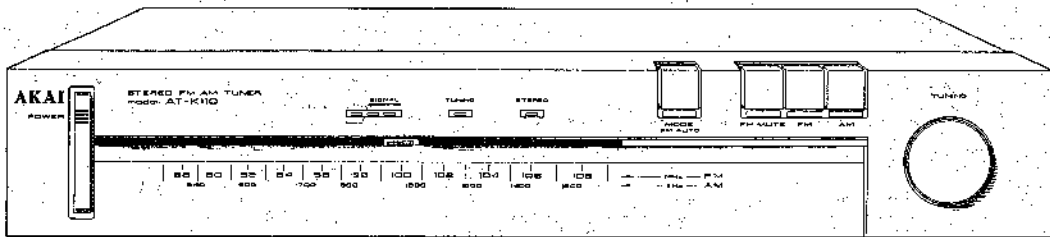

FM AM STEREO TUNER

MODEL **AT-K110**

STEREO INTEGRATED AMPLIFIER

MODEL **AM-U110**

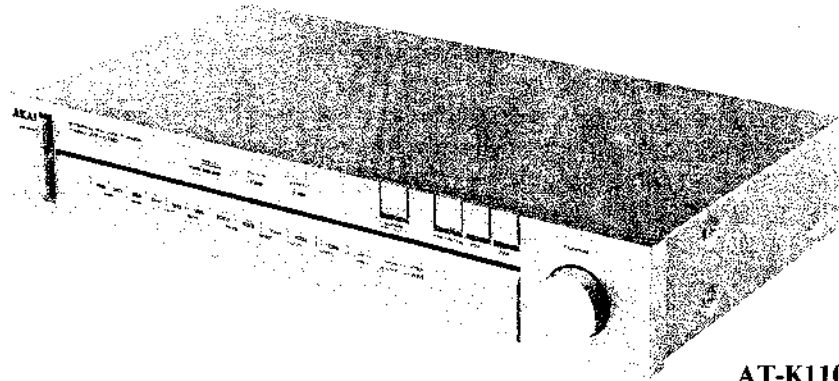

AT-K110

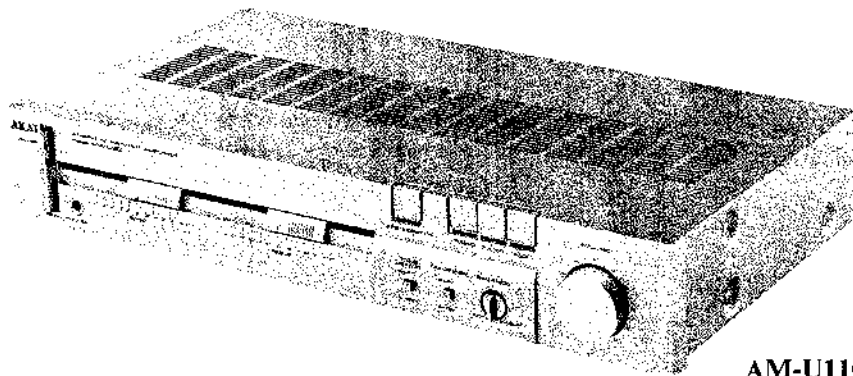

AM-U110

FM AM STEREO TUNER

MODEL **AT-K110**

STEREO INTEGRATED AMPLIFIER

MODEL **AM-U110**

TABLE OF CONTENTS

SECTION 1	SERVICE MANUAL AT-K110.....	3
SECTION 2	SERVICE MANUAL AM-U110	14
SECTION 3	PARTS LIST	23
SECTION 4	SCHEMATIC DIAGRAM	32

SAFETY INSTRUCTIONS

SAFETY CHECK AFTER SERVICING

Confirm the specified insulation resistance between power cord plug prongs and externally exposed parts of the set is greater than 10 Mohms, but for equipment with external antenna terminals (tuner, receiver, etc.) and is intended for **C** or **A**, specified insulation resistance should be more than 2.2 Mohms (ground terminals, microphone jacks, headphone jacks, line-in-out jacks etc.)

PRECAUTIONS DURING SERVICING

1. Parts identified by the Δ symbol parts are critical for safety.
Replace only with parts number specified.
2. In addition to safety, other parts and assemblies are specified for conformance with such regulations as those applying to spurious radiation. These must also be replaced only with specified replacements.
Examples: RF converters, tuner units, antenna selector switches, RF cables, noise blocking capacitors, noise blocking filters, etc.
3. Use specified internal wiring. Note especially:
 - 1) Wires covered with PVC tubing
 - 2) Double insulated wires
 - 3) High voltage leads
4. Use specified insulating materials for hazardous live parts. Note especially:
 - 1) Insulation Tape
 - 2) PVC tubing
 - 3) Spacers (Insulating Barriers)
 - 4) Insulation sheets for transistors
5. When replacing AC primary side components (transformers, power cords, noise blocking capacitors, etc.), wrap ends of wires securely about the terminals before soldering.

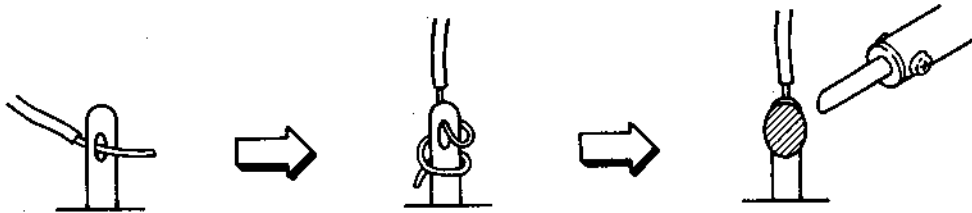

6. Observe that wires do not contact heat producing parts (heatsinks, oxide metal film resistors, fusible resistors, etc.).
 7. Check that replaced wires do not contact sharp edged or pointed parts.
 8. Also check areas surrounding repaired locations.
 9. Use care that foreign objects (screws, solder droplets, etc.) do not remain inside the set.
-

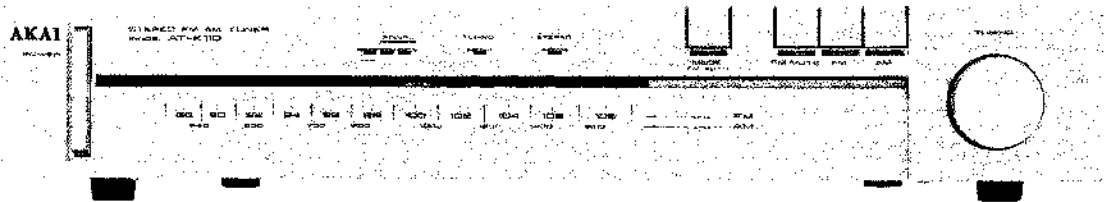

SECTION 1

SERVICE MANUAL

MODEL AT-K110

TABLE OF CONTENTS

I. SPECIFICATIONS	4
II. DISMANTLING OF UNIT	5
III. CONTROLS	6
IV. PRINCIPAL PARTS LOCATION.....	7
V. VOLTAGE CONVERSION	8
VI. TUNER ADJUSTMENTS	9
1. AM SECTION ADJUSTMENTS.....	10
2. FM SECTION ADJUSTMENTS	11
VII. COMPOSITION OF VARIOUS P. C BOARDS	20

For basic adjustments, measuring methods, and operating principles, refer to GENERAL TECHNICAL MANUAL.

I. SPECIFICATIONS

FM TUNER SECTION	
TUNING FREQUENCY RANGE	87.5 MHz to 108.0 MHz
SENSITIVITY USABLE (S/N = 30 dB) QUIETING (S/N = 50 dB)	12.7 dBf (Mono)/27.2 dBf (Stereo) 19.2 dBf (Mono)/40.2 dBf (Stereo)
CAPTURE RATIO	2.0 dB
SELECTIVITY (± 400 kHz)	60 dB
IMAGE REJECTION	50 dB
IF REJECTION	80 dB
SPURIOUS REJECTION	80 dB
AM SUPPRESSION	50 dB
SUB CARRIER SUPPRESSION	55 dB
S/N (MONO/STEREO)	70/62 dB
T.H.D. (MONO/STEREO)	0.3/0.4% (± 75 kHz Deviation)
STEREO SEPARATION	38 dB
MUTING THRESHOLD LEVEL	22 dB
ANTENNA INPUT IMPEDANCE	300 ohms

AM TUNER SECTION	
TUNING FREQUENCY RANGE	525 kHz to 1,605 kHz
USABLE SENSITIVITY (IHF) LOOP ANTENNA	300 μ V/m
SELECTIVITY	35 dB
IMAGE REJECTION	45 dB
IF REJECTION	35 dB
S/N	40 dB
T.T.D.	1.0%

OUTPUT SECTION	
OUTPUT VOLTAGE FM (100% MODULATION)	550 mV
POWER REQUIREMENTS	120V, 60 Hz for U.S.A. and Canada 220V, 50 Hz for Europe except UK 240V, 50 Hz for UK and Australia 110V/220V/240V, 50/60 Hz internally switchable for other countries.
POWER CONSUMPTION	6W
DIMENSIONS	440 (W) \times 80 (H) \times 246 (D) mm (17.3 \times 3.1 \times 9.7) inches
WEIGHT	2.9 kg (6.4 lbs)

* For improvement purposes, specifications and design are subject to change without notice.

II. DISMANTLING OF UNIT

AT-K110

In case of trouble, etc. necessitating dismantling, please dismantle in the order shown in the photographs. Reassemble in reverse order.

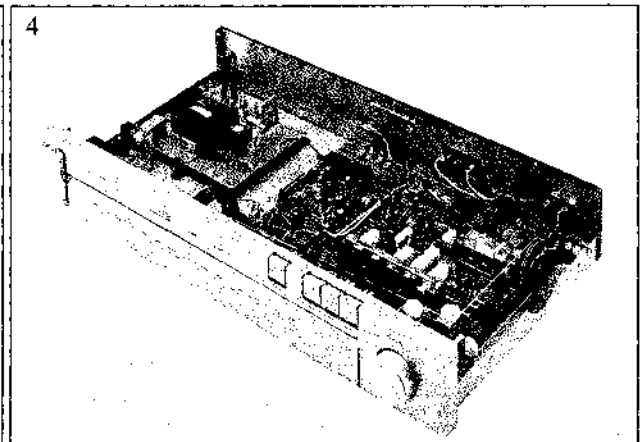
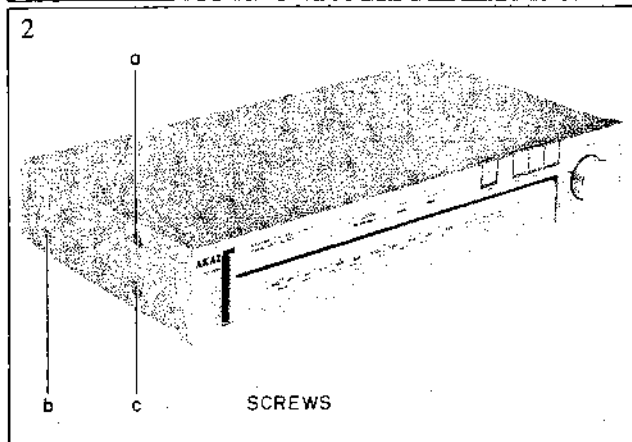
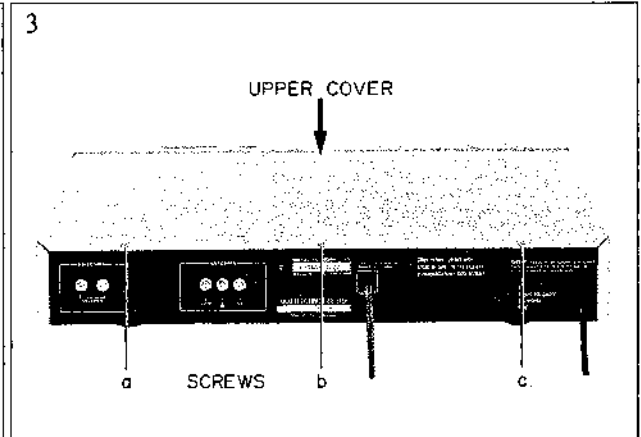
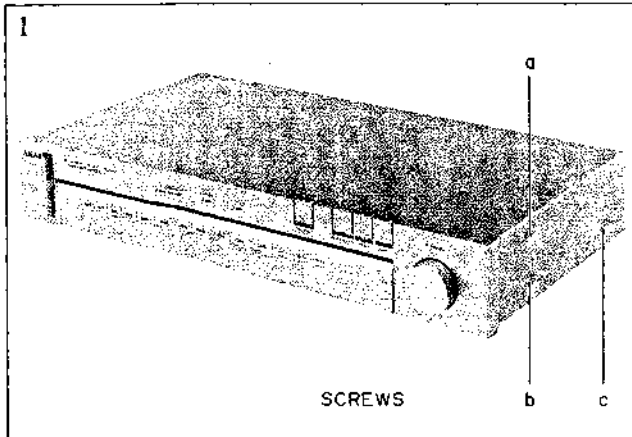

III. CONTROLS

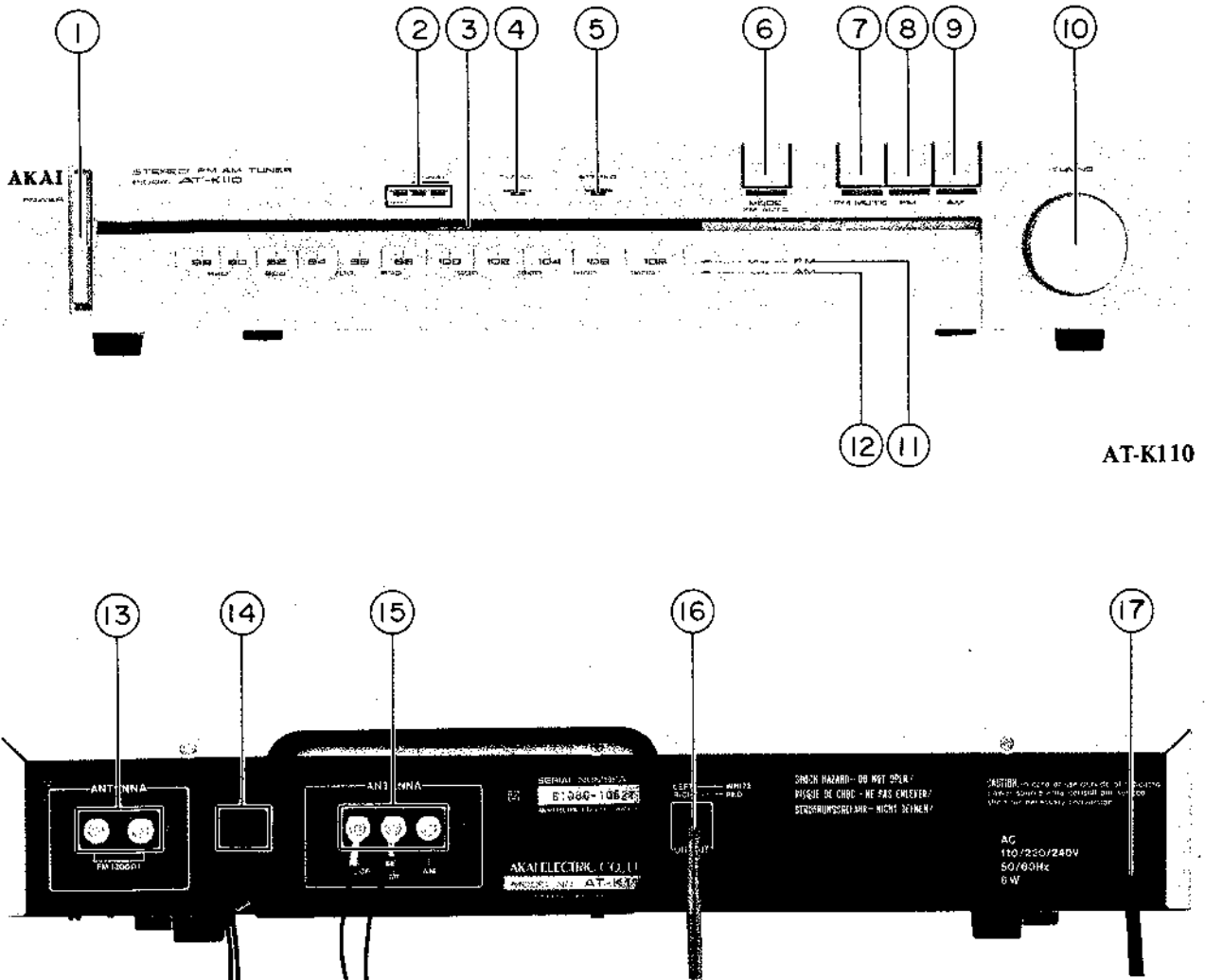

Fig. 1

- | | |
|----------------------------------|----------------------------|
| 1. POWER SWITCH | 10. TUNING KNOB |
| 2. SIGNAL STRENGTH INDICATORS | 11. FM DIAL SCALE |
| 3. FREQUENCY INDICATOR | 12. AM DIAL SCALE |
| 4. FM TUNING INDICATOR | 13. FM ANTENNA TERMINALS |
| 5. FM STEREO INDICATOR | 14. AM LOOP ANTENNA HOLDER |
| 6. FM MODE BUTTON WITH INDICATOR | 15. AM ANTENNA TERMINALS |
| 7. FM MUTE BUTTON WITH INDICATOR | 16. OUTPUT PIN CORD |
| 8. FM BUTTON WITH INDICATOR | 17. AC POWER CORD |
| 9. AM BUTTON WITH INDICATOR | |

IV. PRINCIPAL PARTS LOCATION

AT-K110

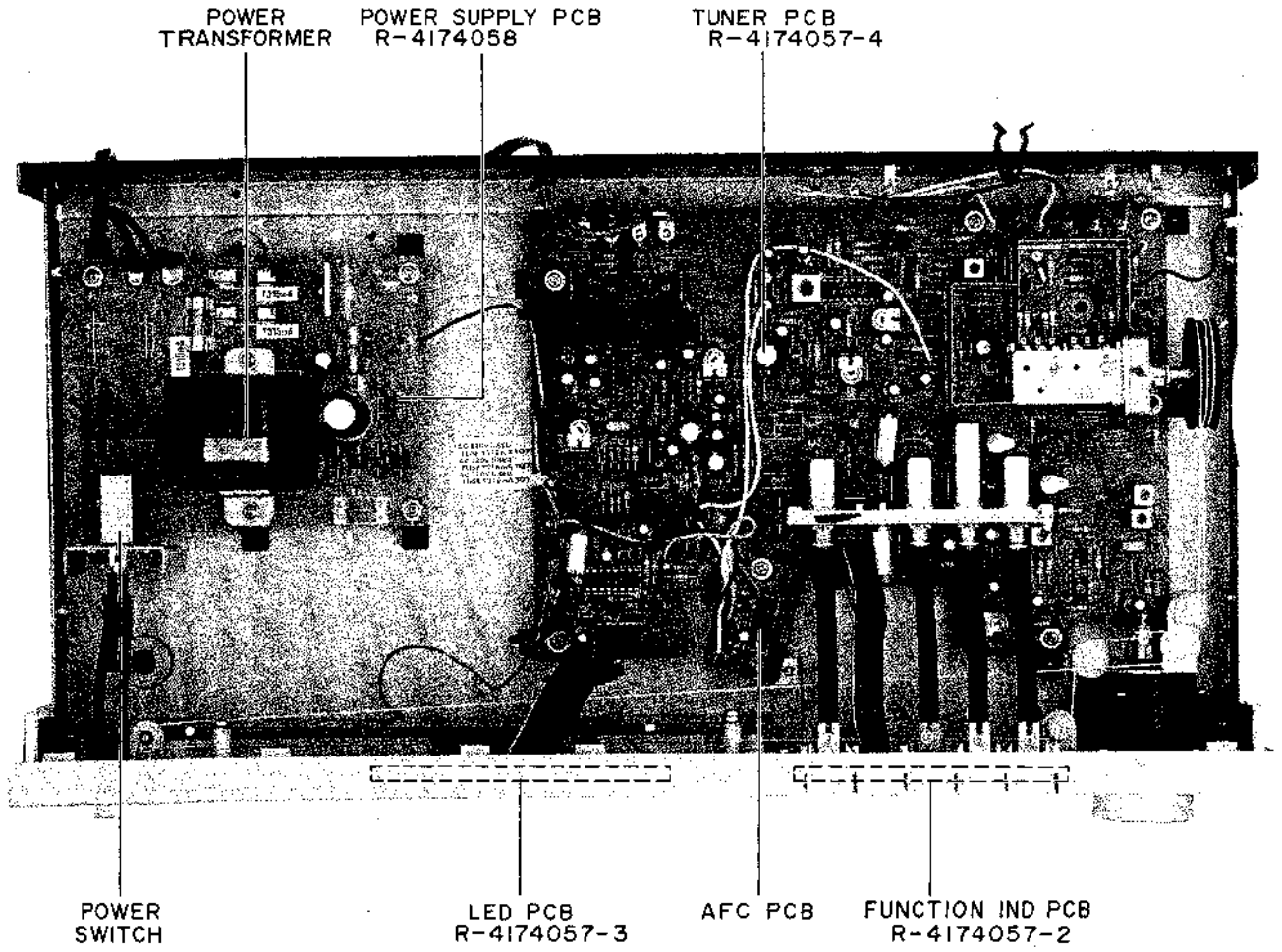

Fig. 2 Top View

V. VOLTAGE CONVERSION

MODEL AT-K110

Models for Canada, U.S.A., Europe, UK and Australia are not equipped with this facility.

Each machine is preset at the factory according to destination, but some machines can be set to 110V, 220V, or 240V as required. If voltage change is necessary, this can be accomplished as follows.

- 1) Disconnect the power cord.
- 2) Loosen the holding screws and remove the top panel.
- 3) Remove the Line Voltage Fuse and insert the required Line Voltage Fuse into the proper Fuse Holder, explicitly following the printed instructions.

110V AREAS : F3 T315mA 250V

220V AREAS : F2 T315mA 250V

240V AREAS : F1 T315mA 250V

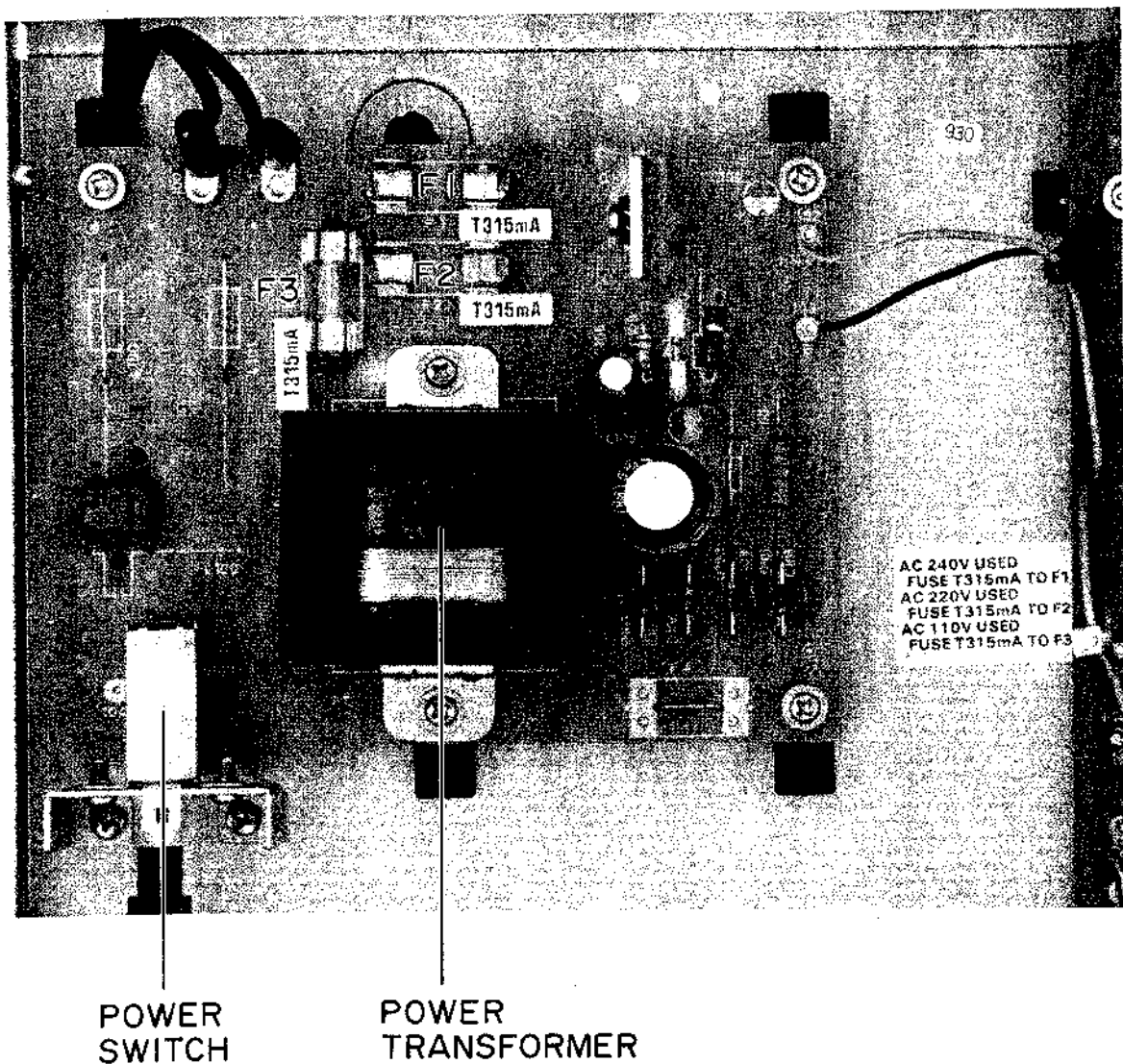

Fig. 3 Voltage Conversion (U Model Only)

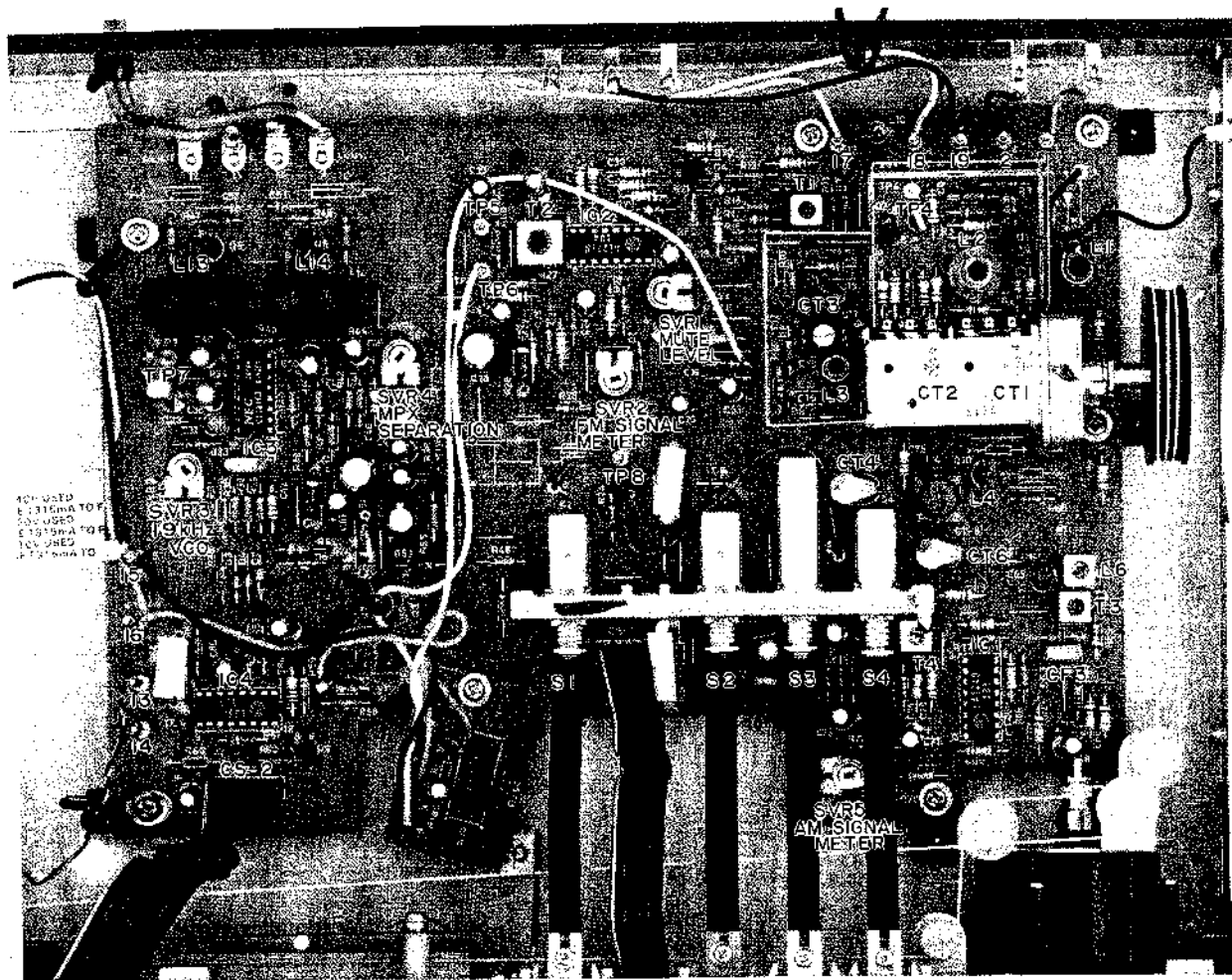

Fig. 4 Tuner P.C Board (Parts Side View)

1. AM SECTION ADJUSTMENTS (Refer to Figs. 4, 5)

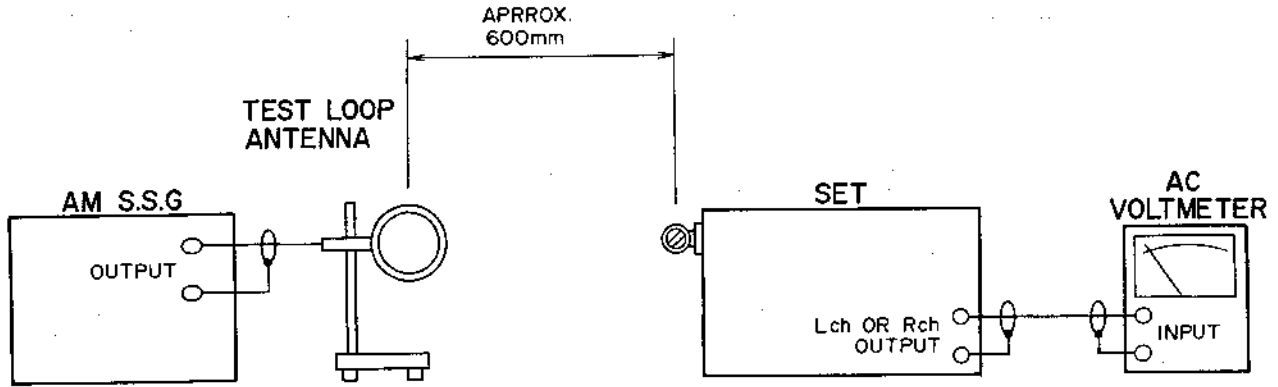

Fig 5 Instrument Connections For AM Section Adjustments

Unless otherwise specified, use the adjustment points provided on the Tuner P.C Board (Fig. 4)

Step	Adjustment Item	S.S.G.		Dial Pointer Position	Adjustment Point	Result & Remarks
		Frequency	A.T.T.			
1	IF	468 kHz	74 dB	Lower End	T3(BLK) T4 (YLW)	Maximum Output Level.
2	AM Frequency Range	515 kHz	64 dB	Lower End	L6 L4	Maximum Output Level.
3		1,650 kHz	64 dB	Upper End	CT6 CT4	Maximum Output Level.
4	AM Sensitivity	600 kHz	54 dB	600 kHz	L4	Maximum Output Level.
5		1,400 kHz	54 dB	1,400 kHz	CT4	
6	AM Signal Meter	1,000 kHz	94 dB	1,000 kHz	SVR5	Third LED of SIGNAL LED lights up.

2. FM SECTION ADJUSTMENTS

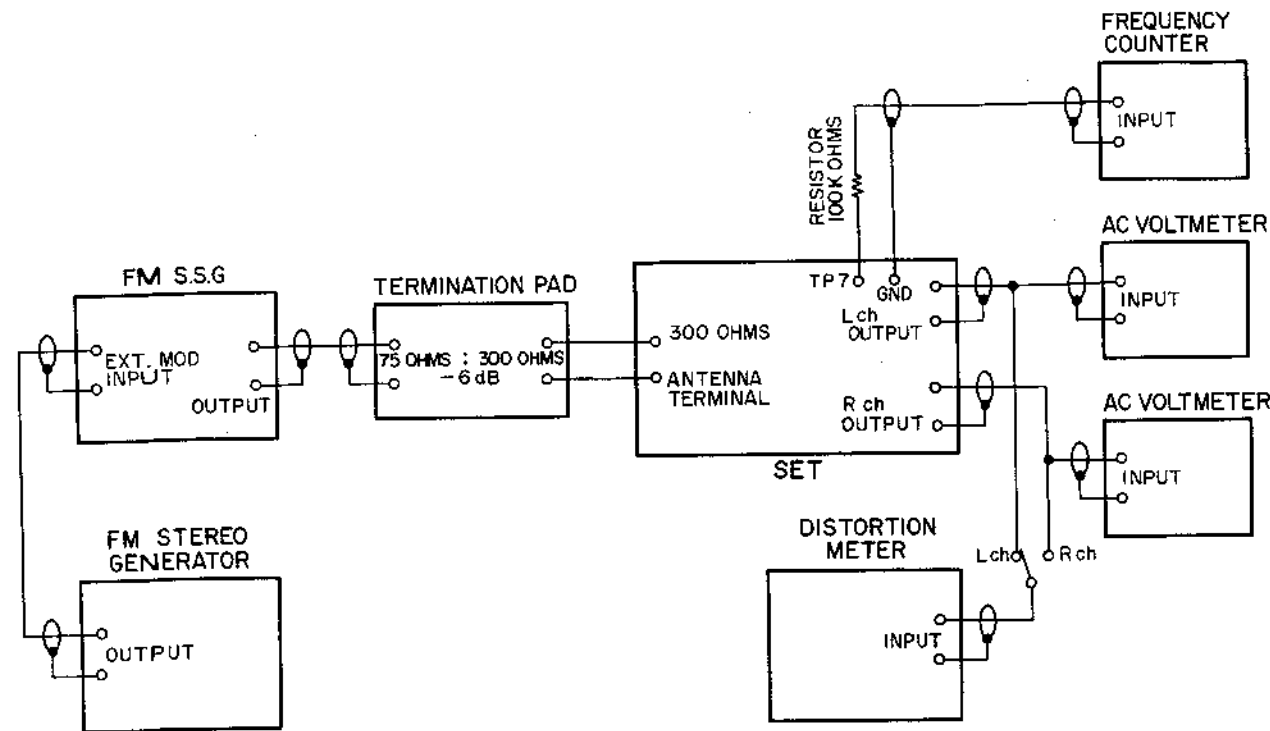
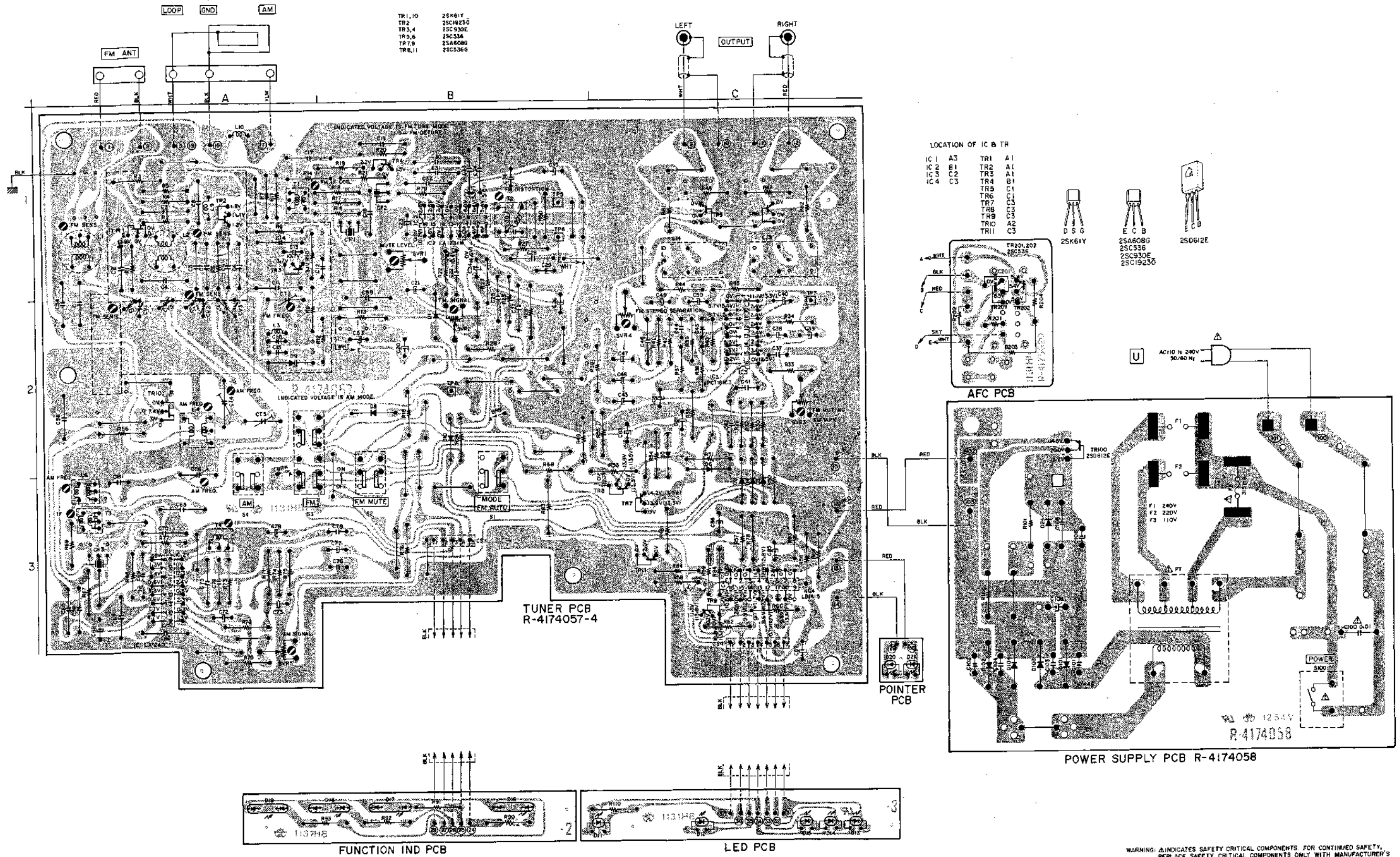

Fig. 6 Instrument Connections

Step	Adjustment Item	S.S.G.		Dial Pointer Position	Adjustment Point	Result & Remarks
		Frequency	A.T.T.			
1	Front-end IF Coil	No Signal		98 MHz	T1	Maximum Noise Level.
2	Distortion Factor	98 MHz	70 dB	98 MHz	T2	Less than 0.3% in both channels.
3	Frequency Range	87.3 MHz	50 dB	Lower End	L3	Maximum Output Level.
		108.3 MHz	50 dB	Upper End	CT3	
4	Sensitivity	90 MHz	15 dB	90 MHz	L1, L2	Maximum Output Level.
		106 MHz	15 dB	106 MHz	CT1, CT2	
5	Signal Meter	98 MHz	20 dB	98 MHz	SVR2	First LED of SIGNAL LED lights up.
6	Muting Level	98 MHz	20 dB	98 MHz	SVR3	Mute Switch to ON. Output Level is reduced Zero.
7	MPX				SVR3	FM AUTO Switch to ON. 19 kHz.
8	Stereo Separation	98 MHz	50 dB	98 MHz	SVR4	FM AUTO Switch to ON. 38 dB

VII. COMPOSITION OF VARIOUS P.C BOARDS

1) Tuner P. C Board R-4174057-4, Power Supply P. C Board R-4174058, Function IND P.C Board, LED P. C Board, AFC P. C Board and Pointer P. C Board.



2) Power Supply P. C Board R-4174058

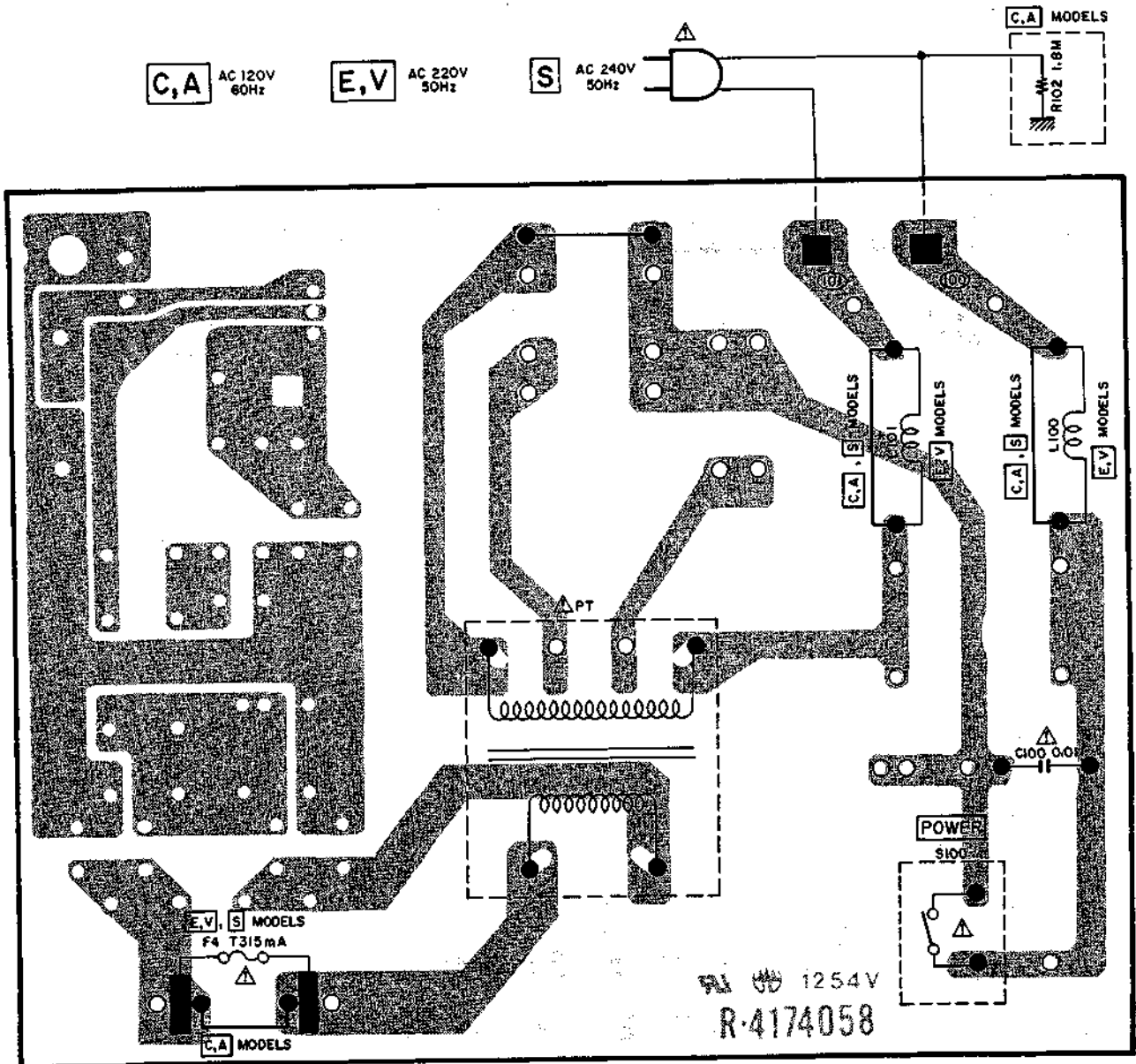

POWER SUPPLY PCB R-4174058

WARNING: INDICATES SAFETY CRITICAL COMPONENTS. FOR CONTINUED SAFETY,
 REPLACE SAFETY CRITICAL COMPONENTS ONLY WITH MANUFACTURER'S
 RECOMMENDED PARTS.
 AVERTISSEMENT: A.N. INDIQUE LES COMPOSANTS CRITIQUES DE SÛRETÉ. POUR
 MAINTENIR LE DEGRÉ DE SÛRETÉ DE L'APPAREIL, NE REMPLACER LES
 COMPOSANTS DONT LE FONCTIONNEMENT EST CRITIQUE POUR LA SÛRETÉ
 QUE PAR DES PIÈCES RECOMMANDÉES PAR LE FABRICANT.

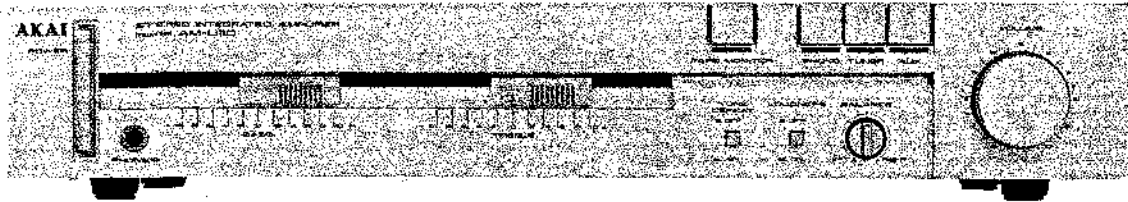

SECTION 2

SERVICE MANUAL

MODEL AM-U110

TABLE OF CONTENTS

I. SPECIFICATIONS	15
II. DISMANTLING OF UNIT	16
III. CONTROLS	17
IV. PRINCIPAL PARTS LOCATION.....	18
V. VOLTAGE CONVERSION	19
VI. COMPOSITION OF VARIOUS P.C BOARDS.....	20

For basic adjustments, measuring methods, and operating principles, refer to GENERAL TECHNICAL MANUAL.

I. SPECIFICATIONS

AM-U110

POWER AMPLIFIER SECTION	
RATED POWER OUTPUT (2 CHANNELS DRIVEN) 40 to 20,000 Hz 1 kHz	8 ohms 22W/0.3% 25W/0.3%
POWER BANDWIDTH (IHF -3 dB, 8 ohms)	10 Hz to 30 kHz/0.3%
SIGNAL TO NOISE RATIO (IHF-A) PHONO AUX	70 dB 90 dB
RESIDUAL NOISE (8 ohms)	1.3 mV
CHANNEL SEPARATION (IHF, 1 kHz)	40 dB (1 kHz)/36 dB (10 kHz)
DAMPING FACTOR (1 kHz, 8 ohms)	27
OUTPUT SPEAKERS HEADPHONES	4 to 16 ohms 4 to 16 ohms
PREAMPLIFIER SECTION	
INPUT SENSITIVITY/IMPEDANCE PHONO AUX TUNER TAPE	2.5 mV/47 kohms 150 mV/47 kohms 150 mV/47 kohms 150 mV/47 kohms
OUTPUT LEVEL/IMPEDANCE TAPE REC	(PIN) 150 mV/2 kohms
FREQUENCY RESPONSE PHONO (RIAA DEVIATION)	± 1 dB
TONE CONTROL BASS TREBLE	± 8 dB 100 Hz ± 6 dB kHz
LOUDNESS CONTROL (VOLUME SET AT -30 dB POSITION)	+10 dB (100 Hz), +6 dB (10 kHz)
PHONO MAX. INPUT (1 kHz)	120 mV
POWER REQUIREMENT	120V, 60 Hz for U.S.A. and Canada 220V, 50 Hz for Europe except UK 240V, 50 Hz for UK and Australia 110 - 120V/220V/240V, 50/60 Hz switchable for other countries.
POWER CONSUMPTION	110W
DIMENSIONS	440 (W) × 80 (H) × 246 (D) mm (17.3 × 3.0 × 9.7 inches)
WEIGHT	4.6 kg (10.1 lbs)

* For improvement purposes, specifications and design are subject to change without notice.

II. DISMANTLING OF UNIT

In case of trouble, etc. necessitating dismantling, please dismantle in the order shown in the photographs. Reassemble in reverse order.

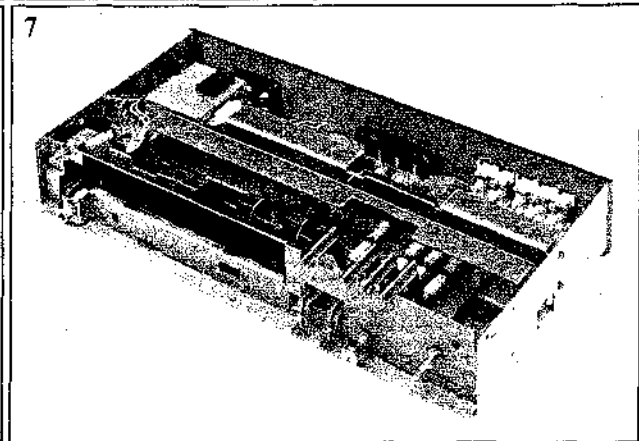
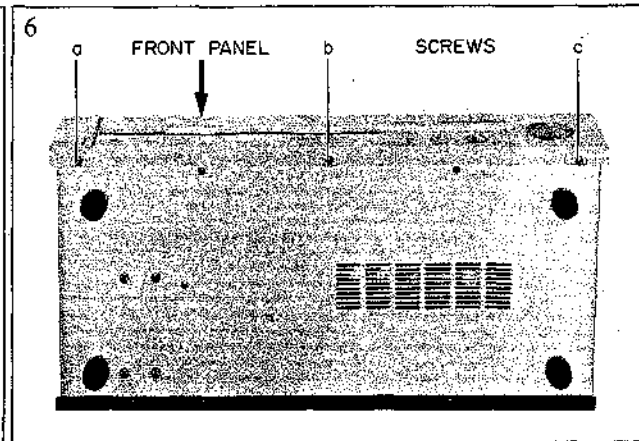
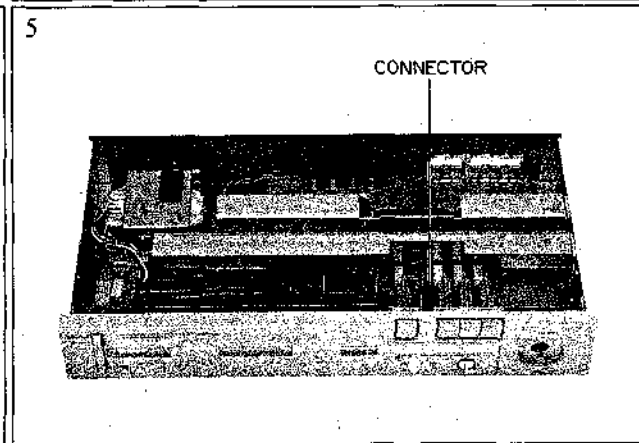
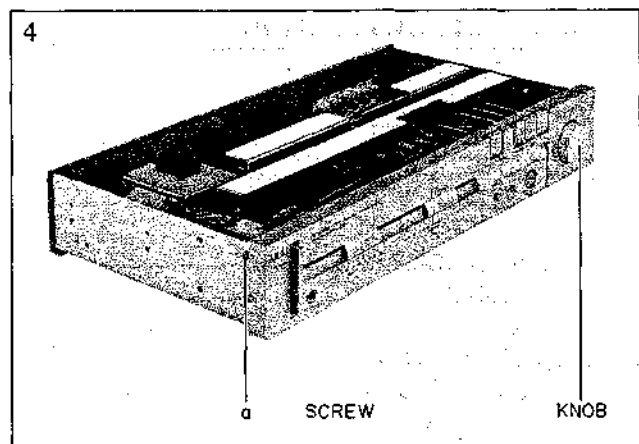
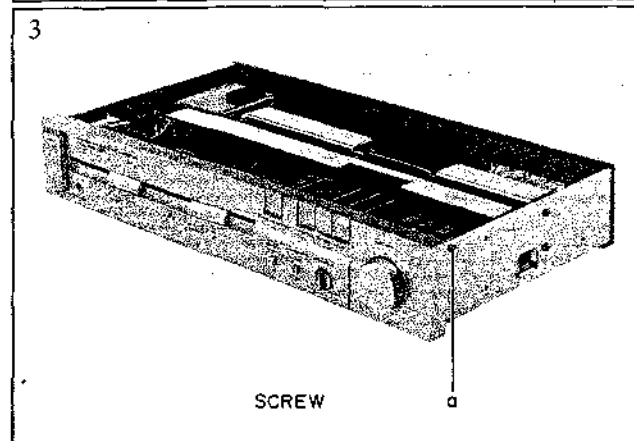
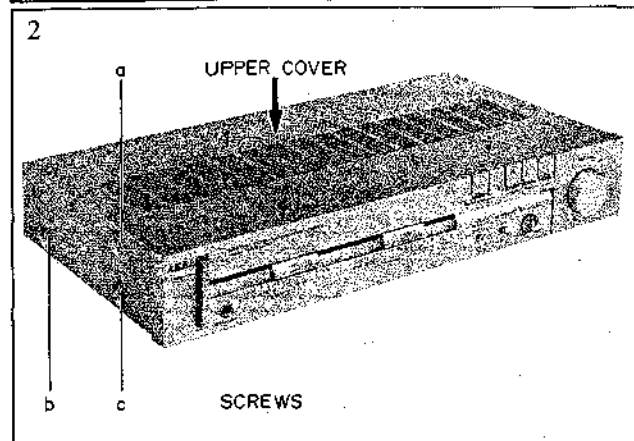
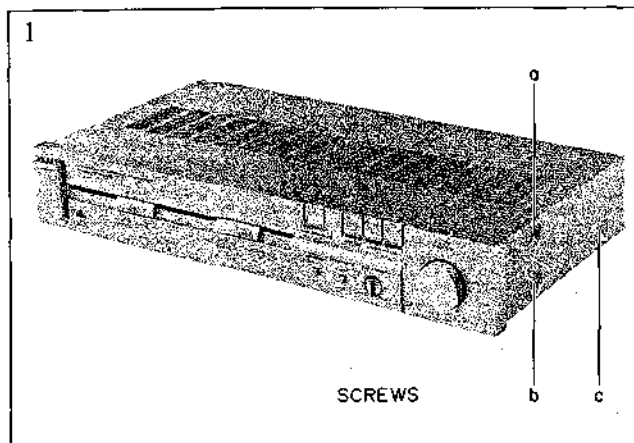

III. CONTROLS

AM-U110

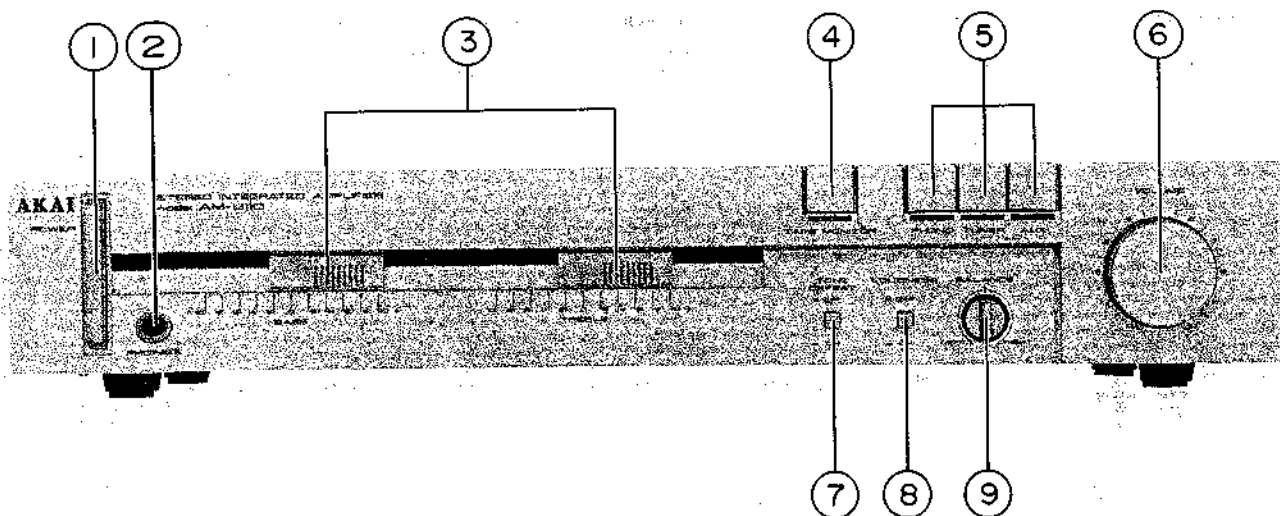

AM-U110

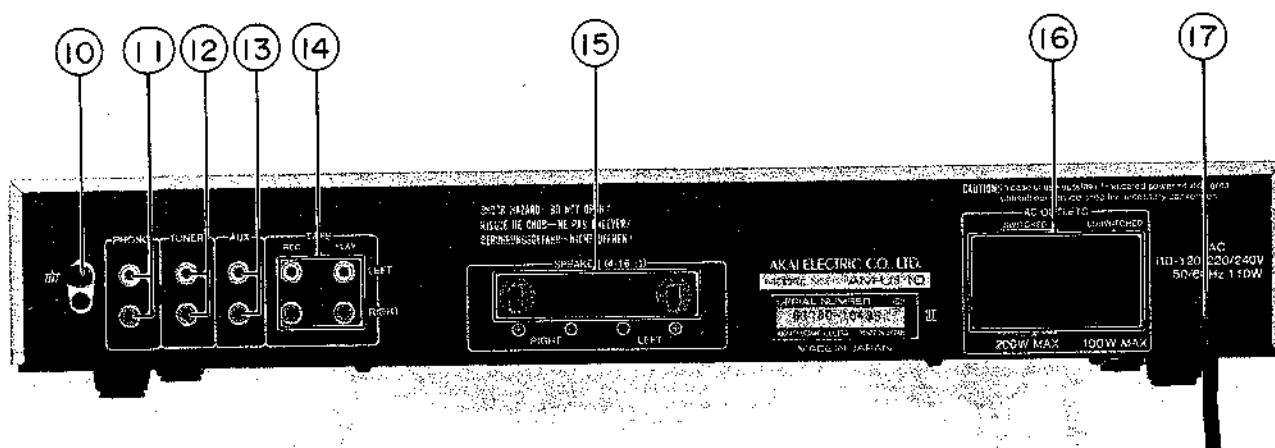

Fig. 1

- | | |
|--|--|
| 1. POWER SWITCH | 11. PHONO JACKS |
| 2. HEADPHONE JACK (PHONES) | 12. TUNER JACKS |
| 3. TONE CONTROLS | 13. AUX JACKS |
| 4. TAPE MONITOR SWITCH WITH INDICATOR | 14. TAPE SYSTEM REC/PLAY JACKS |
| 5. INPUT SELECTOR SWITCHES WITH INDICATORS | 15. SPEAKER TERMINALS (RIGHT AND LEFT) |
| 6. VOLUME CONTROL | 16. AC OUTLETS (SOME MODELS ARE NOT EQUIPPED WITH THIS FACILITY.) |
| 7. TONE DEFEAT SWITCH | 17. POWER CORD (SOME MODELS ARE EQUIPPED WITH AN AC INLET INSTEAD OF AN POWER CORD. CONNECT WITH AN APPROPRIATE POWER CORD.) |
| 8. LOUDNESS SWITCH | |
| 9. STEREO BALANCE CONTROL | |
| 10. GROUND TERMINAL (⚡) | |

IV. PRINCIPAL PARTS LOCATION

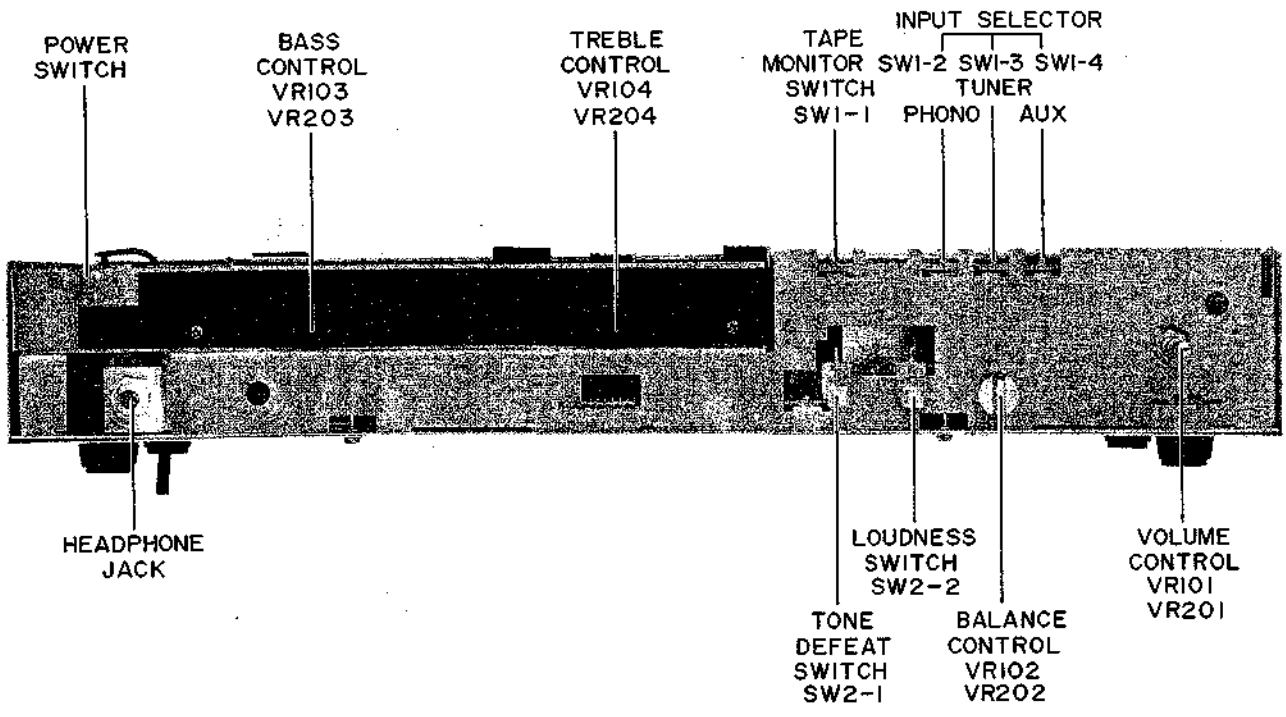

Fig. 2 Front View

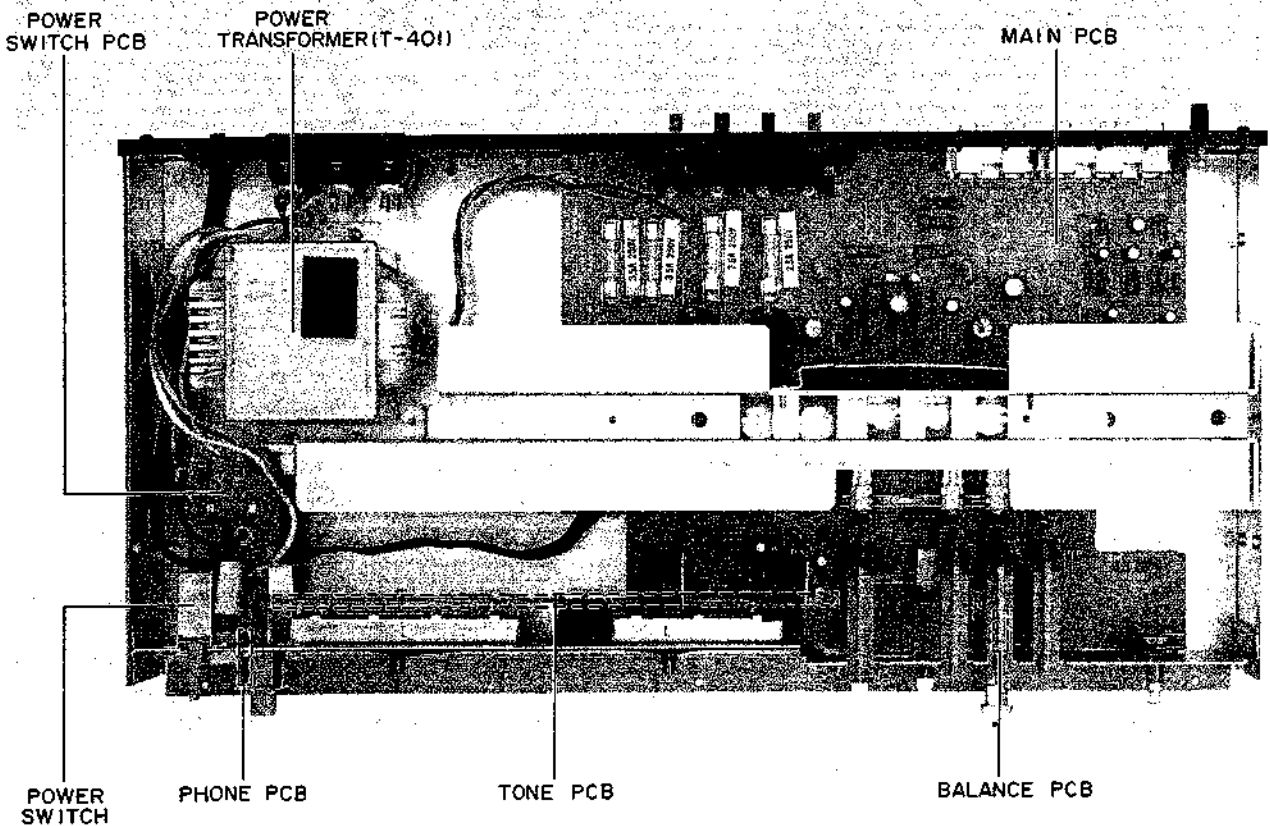

Fig. 3 Top View

V. VOLTAGE CONVERSION

AM-U110

Models for Canada, U.S.A., Europe, UK and Australia are not equipped with this facility.

Each machine is preset at the factory according to destination, but some machines can be set to 110 - 120V, 220V or 240V as required. If voltage change is necessary, this can be accomplished as follows.

- 1) Disconnect the power cord.
- 2) Loosen the holding screws and remove the top panel.
- 3) Remove the Line Voltage wire and fit onto proper pins, explicitly following the printed instructions.

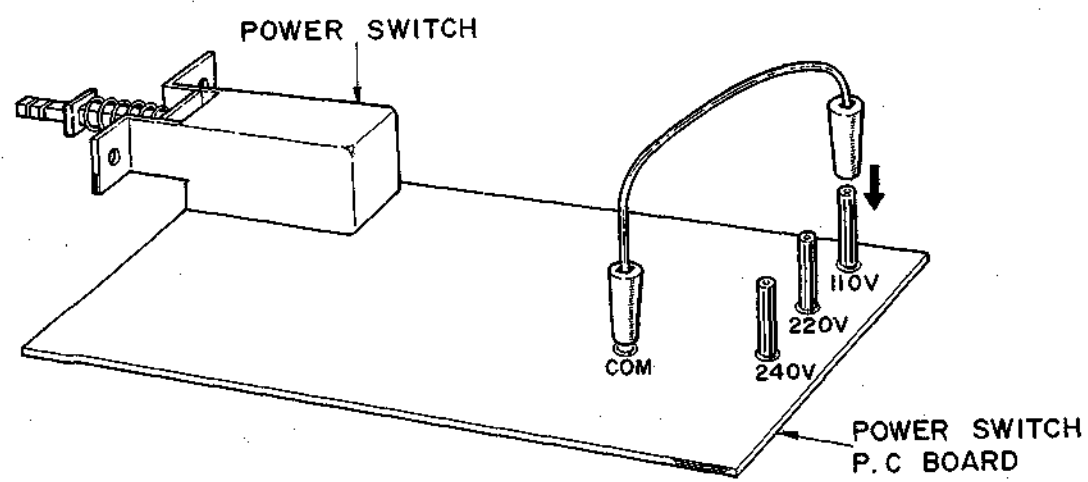

Fig. 4 Voltage Conversion (U/T Model Only)

MEMO

MEMO

SECTION 3

PARTS LIST

TABLE OF CONTENTS

I.	MODEL A1-K110	25
	1. RECOMMENDED SPARE PARTS	25
	2. TUNER P.C BOARD BLOCK	25
	3. POWER SUPPLY P.C BOARD BLOCK	25
	4. ASSEMBLY BLOCK	26
	5. FINAL ASSEMBLY BLOCK	27
II.	MODEL AM-1110	28
	1. RECOMMENDED SPARE PARTS	28
	2. MAIN P.C BOARD BLOCK	28
	3. ASSEMBLY BLOCK	29
	4. FINAL ASSEMBLY BLOCK	30
	INDEX	31

Resistor and Capacitor which are not listed in this parts list please refer to
COMMON LIST FOR SERVICE PARTS.

HOW TO USE THIS PARTS LIST

1. This parts list is compiled by various individual blocks based on assembly process.
2. When ordering parts, please describe parts number, serial number, and model number in detail.
3. How to read list.

The reference number corresponds with illustration or photo number of that particular parts list.

This number corresponds with the Figure Number.

This number corresponds with the individual parts' index number in that figure.

A small "x" indicates the inability to show that particular part in the Photo or Illustration.

12-115x

Ref. No.	Parts No.	Description
----------	-----------	-------------

FLYWHEEL BLOCK #13

12-115x	800425	Flywheel Block Assy. Comp.
12-116	244506	Flywheel Only
12-117x	244754	Felt, Flywheel
12-118	251324	Main Metal Case
12-119	253080	Main Metal

4. The symbol numbers shown on the P.C. Board list can be matched with the Composite Views of components of the Schematic Diagram or Service Manual.
5. The indications of Resistors and Capacitors in the photos of P.C. Board are being eliminated.
6. The shape of the parts and parts name, etc. can be confirmed by comparing them with the parts shown on the Electrical Parts Table of P.C. Board.
7. Both the kind of part and installation position can be determined by the Parts Number. To determine where a parts number is listed, utilize Parts Index at end of Parts List.
It is necessary first of all to find the Parts Number. This can be accomplished by using the Reference Number listed at right of parts number in the Parts Index. (meaning of ref. no. outlined in Item 3 above).
8. Utilize separate "Price List for Parts" to determine unit price. The most simple method of finding parts Price is to utilize the reference number.

CAUTION:

1. When placing an order for parts, be sure to list the parts no., model no., and description. There are instances in which if any of this information is omitted, parts cannot be shipped or the wrong parts will be delivered.
2. Please be careful not to make a mistake in the parts no. If the parts no. is in error, a part different from the one ordered may be delivered.
3. Because parts number and parts unit supply in the Preliminary Service Manual (Basic Parts List) may be partially changed, please use this parts list for all future reference.

WARNING: Δ INDICATES SAFETY CRITICAL COMPONENTS. FOR CONTINUED SAFETY, REPLACE SAFETY CRITICAL COMPONENTS ONLY WITH MANUFACTURER'S RECOMMENDED PARTS.

AVERTISSEMENT: Δ IL INDIQUE LES COMPOSANTS CRITIQUES DE SURETE. POUR MAINTENIR LE DEGRE DE SECURITE DE L'APPAREIL NE REMPLACER LES COMPOSANTS DONT LE FONCTIONNEMENT EST CRITIQUE POUR LA SECURITE QUE PAR DES PIECES RECOMMANDEES PAR LE FABRICANT.

I. MODEL AT-K110

AT-K110

1. RECOMMENDED SPARE PARTS

Because, if the parts listed bellow are on hand, almost any repair can be accomplished, we suggest that you stock these Recommended Spare Parts Items.

REF. NO.	PARTS NO.	DESCRIPTION
1-1	BT-707656	△ TRANS POWER AT-K110 (A)
1-2	BT-707655	△ TRANS POWER AT-K110 (C)
1-3	BT-707658	△ TRANS POWER AT-K110 (E,V)
1-4	BT-707659	△ TRANS POWER AT-K110 (S)
1-5	BT-707248	△ TRANS POWER AT-K110 (U)
1-6	EC-707217	VC AIR
1-7	ED-562386	D GERMA H IS188AM
1-8	ED-322247	D LED SLP-151D RED
1-9	ED-322215	D LED SLP-251D GRN
1-10	ED-336786	D LED SLP-271D GRN
1-11	ED-707253	D SILICON DS135D
1-12	ED-327057	D SILICON H DS422X
1-13	ED-707247	D VARACTOR ITT410AB
1-14	ED-707252	D ZENER GZA15U
1-15	EF-707249	△ FUSE T 315MA (U)
1-16	EI-322248	IC LA1231N
1-17	EI-293185	IC LA1240
1-18	EI-707241	IC LB1415
1-19	EI-707240	IC UPC1161C3
1-20	ER-707233	FILTER CE
1-21	ER-707234	FILTER CE
1-22	ES-706213	△ SW PUSH (U,E,S,V)
1-23	ES-706306	△ SW PUSH (C,A)
1-24	ES-707239	SW PUSH
1-25	ET-707246	TR 2SA608G
1-26	ET-707243	TR 2SC1923O
1-27	ET-707245	TR 2SC536G
1-28	ET-707244	TR 2SC930E
1-29	ET-707251	TR 2SD612E
1-30	ET-707242	TR 2SK61Y
1-31	EV-707236	R S-FIX 103
1-32	EV-707238	R S-FIX 203
1-33	EV-707237	R S-FIX 254
1-34	EV-707235	R S-FIX 503

Symbol For Distination

- U: Universal Area
- A: America
- C: Canada
- E: Europe
- J: Japan
- S: Australia
- V: Germany

2. TUNER P.C BOARD BLOCK

REF. NO.	PARTS NO.	DESCRIPTION
2-1	BA-707216	PC TUNER BLK AT-K110(U)
2-2	BA-707650	PC TUNER BLK AT-K110 (C)
2-3	BA-707651	PC TUNER BLK AT-K110 (A)
2-4	BA-707652	PC TUNER BLK AT-K110 (E)
2-5	BA-707653	PC TUNER BLK AT-K110 (S)
2-6	BA-707654	PC TUNER BLK AT-K110 (V)
2-IC1	EI-293185	IC LA1240
2-IC2	EI-322248	IC LA1231N
2-IC3	EI-707240	IC UPC1161C3
2-IC4	EI-707241	IC LB1415
2-TR1	ET-707242	TR 2SK61Y
2-TR2	ET-707243	TR 2SC1923O
2-TR3, 4	ET-707244	TR 2SC930E
2-TR5, 6	ET-707245	TR 2SC536G
2-TR7	ET-707246	TR 2SA608G
2-TR8	ET-707245	TR 2SC536G
2-TR9	ET-707246	TR 2SC608G
2-TR10	ET-707242	TR 2SK61Y
2-TR11	ET-707245	TR 2SC536G
2-D1 to 6	ED-327057	D SILYCON H DS442X
2-D8	ED-327057	D SILICON H DS442X
2-D9	ED-707247	D VARACTOR ITT 410AB
2-D10	ED-562386	D GERM H IS188AM (U)
2-D10	ED-327057	D SILICON H DS442X
		(C, A, E, S, V)
2-CV-1-5	EC-707217	VC AIE
2-L1	EO-707219	COIL TUN
2-L2	EO-707221	COIL TUN
2-L3	EO-707222	COIL TUN
2-L4	EO-707223	COIL TUN
2-L6	EO-707224	COIL OSC 2
2-L9	EO-707225	COIL FIX
2-L10	EO-707226	COIL FIX (U)
2-L13, 14	EO-707227	COIL FIX
2-L15	EO-707662	COIL FIX (V)
2-L16	EO-707663	COIL FIX (V)
2-T1	EO-707228	COIL IFT
2-T2	EO-707229	COIL IFT
2-T3	EO-707230	COIL IFT
2-T4	ER-707231	FILTER
2-CT3	ER-707232	C S-FIX
2-CT4	ER-707232	C S-FIX
2-CT6	EO-707232	C S-FIX
2-CF1, 2	ER-707223	FILTER CE
2-CF3	ER-707234	FILTER CE
2-SVR1, 2	EO-707235	R S-FIX 503
2-SVR3	EO-707236	R S-FIX 103
2-SVR4	EO-707237	R S-FIX 254
2-SVR5	EO-707238	R S-FIX 203 (U)
2-SVR5	EO-707235	R S-FIX (C, A, E, S, V)
2-S1-4	ES-707239	SW PUSH
2-C37	EC-672287	C STY V 511J 50.0 DC (U)
2-C63	EC-304849	C STY V 361J 50 DC (U)

3. POWER SUPPLY P.C BOARD BLOCK

REF. NO.	PARTS NO.	DESCRIPTION
3-TR100	ET707251	TR 2SD612E
3-D100	ED-707252	D ZENER GZA15U
D-101 to 104	ED-707253	D SILICON DS 135D
3-S100	ES-706213	△ SW PUSH (U, E, S, V)
3-S100	ES-706306	△ SW PUSH (C, A)
3-F1	EF-707249	△ FUSE T 315MA (U)
3-L100, 101	EO-707660	COIL FIX (E)
3-L100, 101	EO-707661	COIL FIX (V)
3-R100	ER-341940	R OMF H SNP FS 1W 100J (U)
3-C100	EC-707250	△ C CE 103 250AC (U)
3-C100	EC-706422	△ C CE 103 250AC (C, A)
3-C100	EC-706416	△ C CE 103 250AC (E, S, V)
3-C105	EC-316188	C EC V CUT SM102 25DC (U)

When ordering parts, please quote Parts Number, Description and Model Number.

ASSEMBLY BLOCK

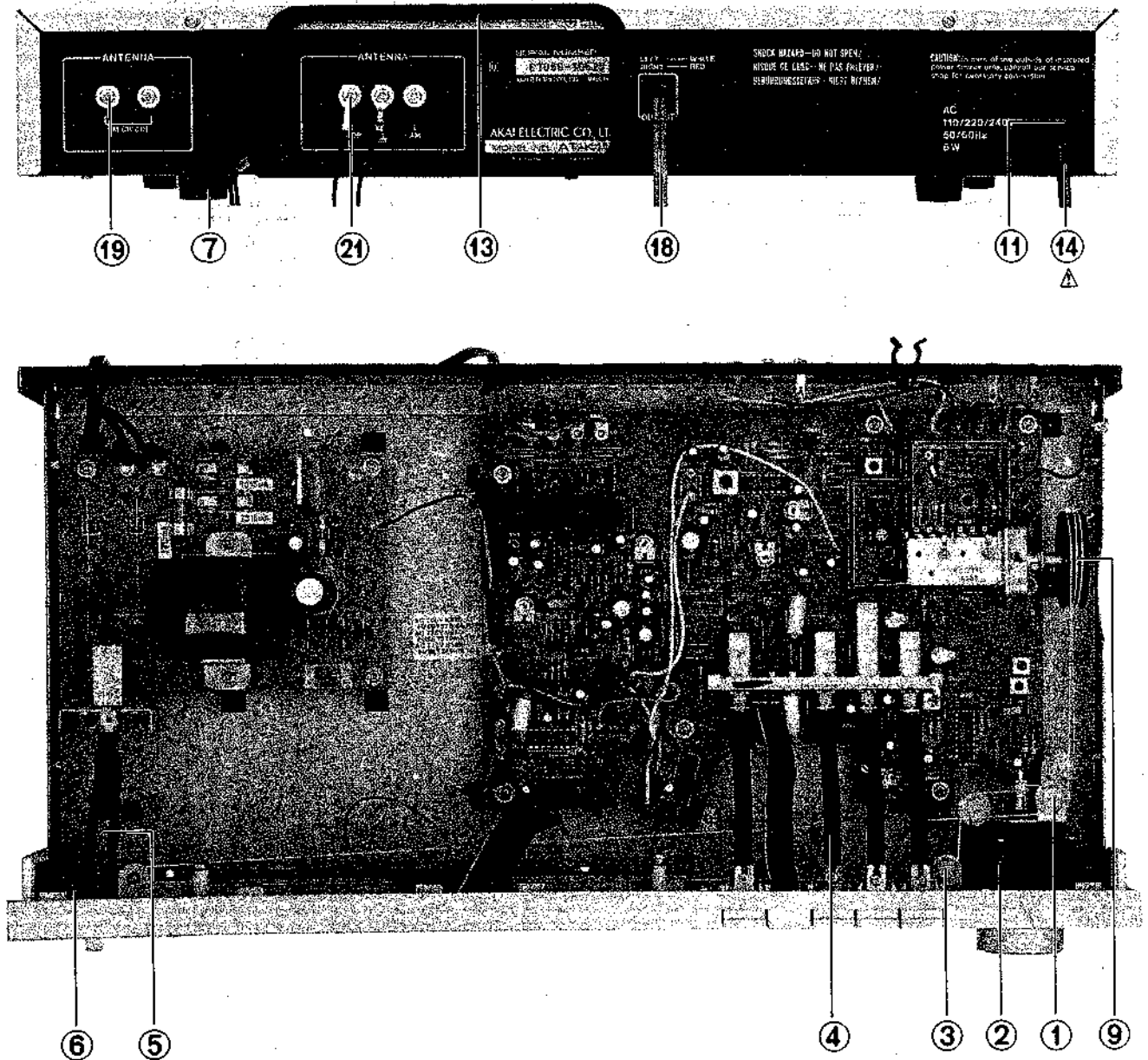

4. ASSEMBLY BLOCK

REF. NO.	PARTS NO.	DESCRIPTION	REF. NO.	PARTS NO.	DESCRIPTION
4-1	TA-707192	PULLEY D12 BLK	4-16x	EW-706423	△ AC CORD (E, V)
4-2	TA-707193	FLYWHEEL BLK	4-17x	EW-707424	△ AC CORD (S)
4-3	TA-707194	PULLEY D7 BLK	4-18	EW-707213	PIN CORD
4-4	TA-707198	LEVER	4-19	EJ-707214	SCREEN TERMINAL 2P (U, E, S, V)
4-5	TA-707202	LEVER KNOB POWER	4-20x	ZS-707648	TERMINAL SCREW 2P (C, A)
4-6	ZG-707203	SP COIL KNOB POWER	4-21	EJ-707215	SCREW TERMINAL 3P (U, E, S, V)
4-7	SA-706208	FOOT	4-22x	ZS-707649	TERMINAL SCREW 3P (C, A)
4-8x	TA-707206	POINTER BLK	4-23x	ED-322215	D LED SLP-251D GRN (POINTER)
4-9	TA-707208	DRUM BLKK	4-24	BT-707246	△ TRANS POWER AT-K110 (U)
4-10x	ZG-707209	SP COIL DRUM	4-25x	BT-707655	△ TRANS POWER AT-K110 (C)
4-11	EZ-706210	STRAIN RELIEF 2P-4 (U)	4-26x	BT-707656	△ TRANS POWER AT-K110 (A)
4-12x	EZ-706319	STRAIN RELIEF (C, A, E, S, V)	4-27x	BT-707658	△ TRANS POWER AT-K110 (E, V)
4-13	EE-707211	ANT LOOP	4-28x	BT-707659	△ TRANS POWER AT-K110 (S)
4-14	EW-707212	△ AC CORD (U)			
4-15x	EW-706647	△ AC CORD (C, A)			

When ordering parts, please quote Parts Number, Description and Model Number.

FINAL ASSEMBLY BLOCK

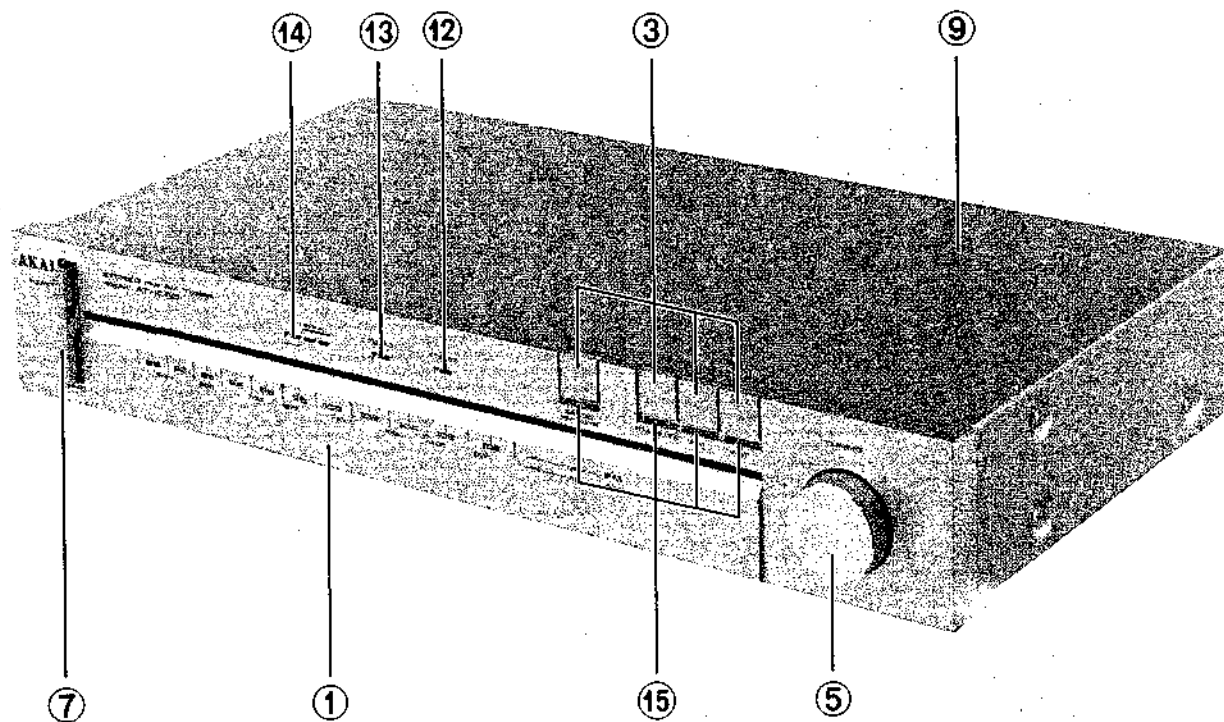

5. FINAL ASSEMBLY BLOCK

REF. NO.	PARTS NO.	DESCRIPTION
5-1	BD-707190	PANEL FRONT AT-K110
5-2x	BD-707191	PANEL FRONT (P) AT-K110-P
5-3	SK-707195	KNOB
5-4x	SK-707197	KNOB (P)
5-5	SK-707199	KNOB TUNING
5-6x	SK-707200	KNOB TUNING
5-7	SK-706202	KNOB (A)
5-8x	SK-707201	KNOB POWER (P)
5-9	SP-707204	UPPER COVER
5-10x	SP-707205	UPPER COVER (P)
5-11x	EE-707210	HOLDER ANT LOOP
5-12	ED-322247	D LED SLP-151D RED
5-13	ED-322215	D LED SLP-251D GRN
5-14	ED-322247	D LED SLP-151D RED
5-15	ED-336786	D LED SLP-271D GRN

II. MODEL AM-U110

1. RECOMMENDED SPARE PARTS

Because, if the parts listed bellow are on hand, almost any repair can be accomplished, we suggest that you stock these Recommended Spare Parts Items.

REF. NO.	PARTS NO.	DESCRIPTION
1-1	BT-707006	TRANS PT-401 (A, C)
1-2	BT-707008	TRANS PT-401 (B, S)
1-3	BT-707007	TRANS PT-401 (E, V)
1-4	BT-707009	TRANS PT-401 (U)
1-5	ED-336786	D LED SLP-271D GRN
1-6	ED-200213	D SILICON DBA40C-K15 200/2.6 A
1-7	ED-328486	D.ZENER H HZ15 3
1-8	ED-313623	D ZENER H HZ22 3
1-9	EF-707004	FUSE T 2A 250V
1-10	EF-707003	FUSE T 3.15A 250V
1-11	EF-704516	FUSE 125V 3.5A
1-12	EF-704519	FUSE 250V 2.5A
1-13	EF-704515	FUSE 250V 3.5A
1-14	EF-704521	FUSE 250V 3A
1-15	EI-213390	IC NJM4558D
1-16	EI-704498	IC STK461
1-17	EJ-706993	PHONE J HLJ-4308-01-040
1-18	EJ-706992	PHONE J HLJ-4308-01-043
1-19	EJ-707041	PIN J 4P
1-20	EJ-707039	PIN J 6P
1-21	EJ-706976	SPEAKER TERMINAL 4P
1-22	ER-707001	R FUSE 1/4W 101
1-23	ER-707015	SPARK KILLER DE1510 E103Z
1-24	ER-707013	SPARK KILLER DE7100FZ 103P
1-25	ER-707014	SPARK KILLER DE7100FX 103P
1-26	ES-707010	SW POWER ESB-90 (A, C)
1-27	ES-707011	SW POWER ESB-90 (E, B, S, V)
1-28	ES-707012	SW POWER ESB-90 (U)
1-29	ES-706995	SW PUSH ESB-62595
1-30	ES-706996	SW PUSH ESB-62596
1-31	ET-245790	TR 2SC1570NP G, H
1-32	EV-706999	VR SLIDE 15A 100K
1-33	EV-707000	VR SLIDE 25A 100K
1-34	EV-706998	VR 1Z 250K x 2
1-35	EV-706997	VR 3BM 250K x 2

2. MAIN PC BOARD BLOCK

REF. NO.	PARTS NO.	DESCRIPTION
2-1	BA-706991	PC MAIN BLK AM-U110(U)
2-2	BA-706989	PC MAIN BLK AM-U110 (A, C)
2-3	BA-706990	PC MAIN BLK AM-U110 (E, B, S, V)
2-IC1	EI-213390	IC NJM4558D
2-IC2	EI-704498	IC STK461
2-TR1	ET-245790	TR 2SC1570NP G, H
2-BD	ED-200213	D SILICON DBA40C-K15 200/2.6A
2-D310, 311	ED-328486	D.ZENER H HZ15 3
2-D312	ED-313623	D ZENER H HZ22 3
2-SW1	ES-706995	SW PUSH ESB-62595
2-SW2	ES-706996	SW PUSH ESB-62596
2-VR101	EV-706997	VR 3BM 250K x 2
2-R133	ER-341329	△ R OMF H SNP FS 3W R33J
2-R134	ER-333015	△ R OMF H SNP FS 2W 4R7J
2-R307, 308	ER-333034	△ R OMF H SNP FS 2W 122J
2-R310	ER-333043	△ R OMF H SNP FS 2W 681J
2-R311	ER-707001	△ R FUSE 1/4W 101
2-C308, 309	EC-707002	△ C EC 472 35DC
2-C310 to 313	EC-684720	△ C CE V YE 103P 500DC
2-F1, 2	EF-704515	△ FUSE 250V 3.5A (U)
2-F3, 4	EF-704519	△ FUSE 250V 2.5A(U)
2-F1, 2	EF-704516	△ FUSE125V3.5A(C, A)
2-F3, 4	EF-704521	△ FUSE250V3A(C, A)
2-F1, 2	EF-707003	△ FUSE T 3.15A 250V (E, B, S, V)
2-F3, 4	EF-707004	△ FUSE T 2A 250V (E, B, S, V)

Symbol For Distination

- U : Universal Area
- A : America
- B : UK
- C : Canada
- E : Europe
- J : Japan
- S : Australia
- V : Germany

ASSEMBLY BLOCK

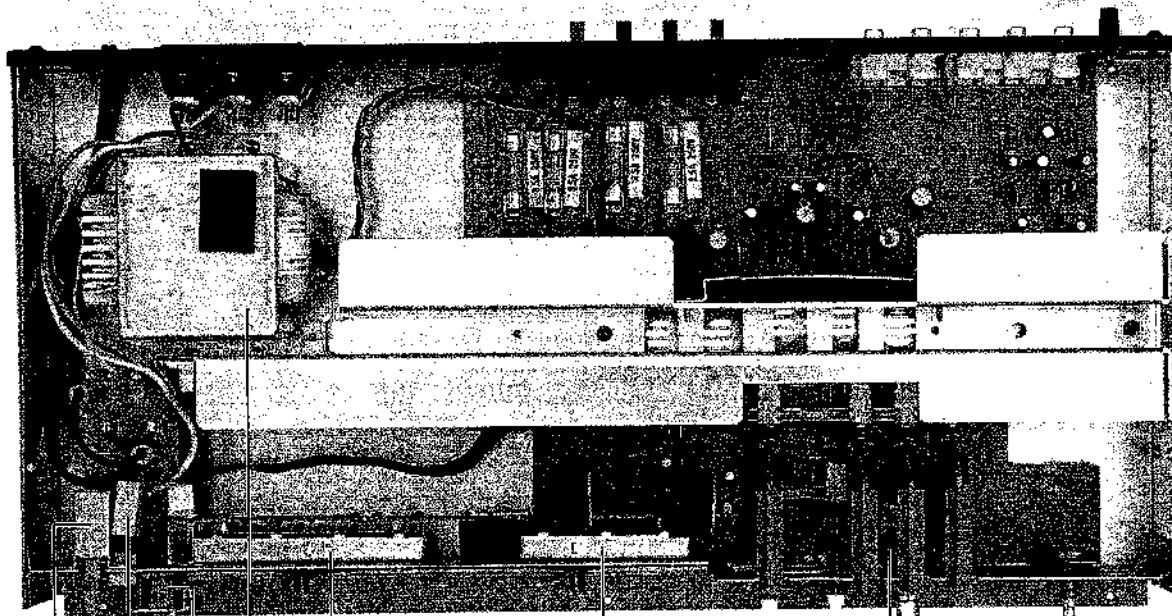
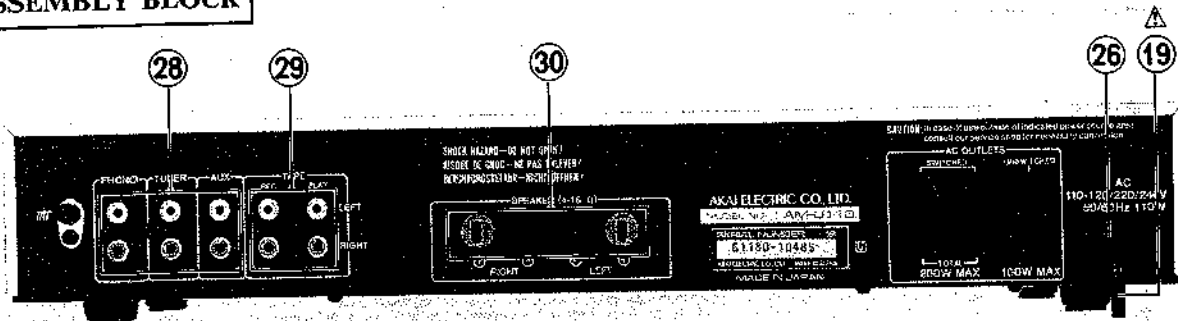

3. ASSEMBLY BLOCK

REF. NO.	PARTS NO.	DESCRIPTION
		INPUT SELECTOR INDICATOR P.C BOARD BLOCK
3-1x	ED-336786	D LED SLP-271D (D301 to 304)
3-2x	ER-341330	R CB H FS RDS 1/2W 222J (R301 to 304)
		PHONE P. C BOARD BLOCK
3-3	EJ-706992	PHONE J HLJ-4308-01-043
3-4x	EJ-706993	PHONE J HLJ-4308-01-040 (P)
3-5x	EJ-341331	R OMF H SNP FS 1W 181J (R139, 239)
		BALANCE P. C BOARD BLOCK
3-6	EV-706998	VR 1Z 250K x 2 (BALANCE)
		TONE P. C BOARD BLOCK
3-7	EV-706999	VR SLIDE 15A 100K (TREBLE)
3-8	EV-707000	VR SLIDE 25A 100K (BASS)
		POWER SW P. C BOARD BLOCK
3-9	ES-707012	Δ SW POWER ESB-90 (U) (SW901)
3-10x	ES-707010	Δ SW POWER ESB-90 (A, C) (SW901)
3-11x	ES-707011	Δ SW POWER ESB-90(E, B, S, V) (SW901)
3-12	ER-707015	Δ SPARK KILLER DE1510 E103Z (SK901)
3-13x	ER-707013	Δ SPARK KILLER DE7100FZ 103P (C, A) (SK901)

REF. NO.	PARTS NO.	DESCRIPTION
3-14x	ER-707014	Δ SPARK KILLER DE7100FZ 103P (E, B, S, V) (SK901)
		ASSEMBLY BLOCK
3-15	BT-707009	Δ TRANS PT-401 (U)
3-16x	BT-707006	Δ TRANS PT-401 (A, C)
3-17x	BT-707007	Δ TRANS PT-401 (E, V)
3-18x	BT-707008	Δ TRANS PT-401 (B, S)
3-19	EW-707021	Δ AC CORD KP-205A VFF (U)
3-20x	EW-707017	Δ AC CORD KP-10 SPT-1 (C, A)
3-21x	EW-707018	Δ AC CORD KP-419C LTCE2F (E, V)
3-22x	EW-707019	Δ AC CORD GTBS-2F (B)
3-23x	EW-707020	Δ AC CORD KP-560 LTSA-2 (S)
3-24	EJ-707042	Δ AC OUTLET TERMINAL 3-THROW (U, A)
3-25x	EJ-707043	Δ AC OUTLET TERMINAL 3-THROW (C)
3-26	EJ-704538	CORD BUSH SR 3P-4 (U, C, A)
3-27x	SZ-631945	STRAIN RELIEF SR-4N-4 (E, B, S, V)
3-28	EJ-707039	PIN J 6P
3-29	EJ-707041	PIN J 4P
3-30	EJ-706976	SPEAKER TERMINALS 4P
3-31	SP-706977	PANEL REAR AM-U110 (U)
3-32x	SP-706978	PANEL REAR AM-U110 (C, A)
3-33x	SP-706979	PANEL REAR AM-U110 (B, S)
3-34x	SP-706980	PANEL REAR AM-U110 (E, S, V)

When ordering parts, please quote Parts Number, Description and Model Number.

FINAL ASSEMBLY BLOCK

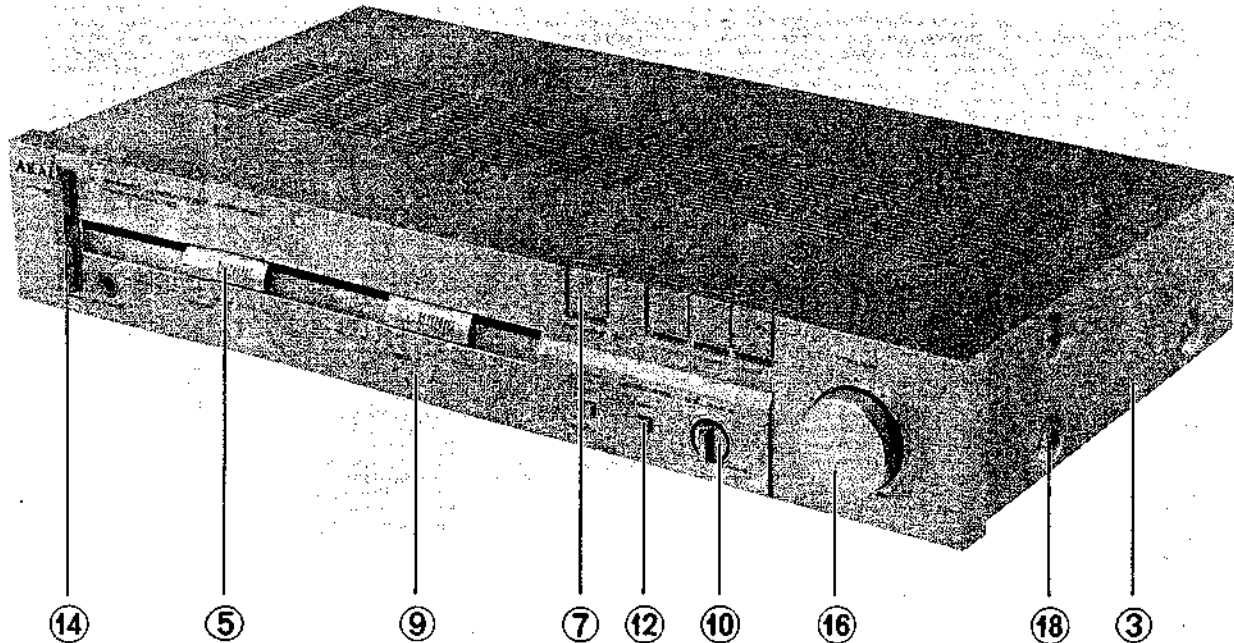

4. FINAL ASSEMBLY BLOCK

REF. NO.	PARTS NO.	DESCRIPTION
4-1	SP-707028	PANEL FRONT AM-U110
4-2x	SP-707029	PANEL FRONT AM-U110-P
4-3	BC-706981	BONNET AM-U110
4-4x	BC-706982	BONNET AM-U110-P
4-5	SK-707025	KNOB TONE BLK AM-110
4-6x	SK-707026	KNOB TONE BLK AM-U110P
4-7	SK-706984	KNOB MODE AM-U110
4-8x	SK-706985	KNOB MODE AM-U110-P
4-9x	ZG-707022	SP KNOB MODE AM- U110
4-10	SK-707030	KNOB BALANCE AM-U110
4-11x	SK-707031	KNOB BALANCE AM-U110-P
4-12	SK-707032	KNOB LOUDNESS AM-U110
4-13x	SK-707033	KNOB LOUDNESS AM-U110-P
4-14	SK-707034	KNOB POWER SW AM-U110
4-15x	SK-707035	KNOB POWER SW AM-U110-P
4-16	SK-707036	KNOB VR AM-U110
4-17x	SK-707037	KNOB VR AM-U110-P
4-18	ZS-322570	ST BID40 x 08STL NI3
4-19x	ZS-322580	ST BID40 x 08STL BNI

When ordering parts, please quote Parts Number, Description and Model Number.

INDEX

1. Model AT-K110

Parts No.	Ref. No. & Symbol No.	Parts No.	Ref. No. & Symbol No.	Parts No.	Ref. No. & Symbol No.	Parts No.	Ref. No. & Symbol No.
BA-707216	2-1	ED-336786	5-15	ER-707231	2-T4	SK-707195	5-3
BA-707650	2-2	ED-562386	2-D10	ER-707233	2-CF1, 2	SK-707197	5-4x
BA-707651	2-3	ED-707247	2-D9	ER-707234	2-CF3	SK-707199	5-5
BA-707652	2-4	ED-707252	3-D100	ES-706213	3-S100	SK-707200	5-6x
BA-707653	2-5	ED-707253	3-D101 to 104	ES-706306	3-S100	SK-707201	5-8x
BA-707654	2-6	EE-707210	5-11x	ES-707239	2-S1-4	SP-707204	5-9
BD-707190	5-1	EE-707211	4-13	ET-707242	2-TR10	SP-707205	5-10x
BD-707191	5-2x	EF-707249	3-F1	ET-707242	2-TR1	TA-707192	4-1
BT-707248	4-24	EF-293185	2-IC1	ET-707243	2-TR2	TA-707193	4-2
BT-707655	4-25x	EI-322248	2-IC2	ET-707244	2-TR3, 4	TA-707194	4-3
BT-707656	4-26x	EI-707240	2-IC3	ET-707245	2-TR5, 6	TA-707198	4-4
BT-707658	4-27x	EI-707241	2-IC4	ET-707245	2-TR8	TA-707202	4-5
BT-707659	4-28x	EJ-707214	4-19	ET-707245	2-TR11	TA-707206	4-8x
EC-304849	2-C63	EJ-707215	4-21	ET-707246	2-TR9	TA-707208	4-9
EC-316188	3-C105	EO-707219	2-L1	ET-707246	2-TR7	ZG-707203	4-6
EC-672287	2-C37	EO-707221	2-L2	ET-707251	3-TR100	ZG-707209	4-10x
EC-706416	3-C100	EO-707222	2-L3	EV-707235	2-SVR5	ZS-707648	4-20x
EC-706422	3-C100	EO-707223	2-L4	EV-707235	2-SVR1, 2	ZS-707649	4-22x
EC-707217	2-CV1-5	EO-707224	2-L6	EV-707236	2-SVR3		
EC-707232	2-CT4	EO-707225	2-L9	EV-707237	2-SVR4		
EC-707232	2-CT6	EO-707226	2-L10	EV-707238	2-SVR5		
EC-707232	2-CT3	EO-707227	2-L13, 14	EW-706423	4-16x		
EC-707250	3-C100	EO-707228	2-T1	EW-706424	4-17x		
ED-322215	4-23x	EO-707229	2-T2	EW-707212	4-14		
ED-322215	5-13	EO-707230	2-T3	EW-707213	4-18		
ED-322247	5-12	EO-707660	3-L100, 101	EW-707647	4-15x		
ED-322247	5-14	EO-707661	3-L100, 101	EZ-706210	4-11		
ED-327057	2-D1 to 6	EO-707662	2-L15	EZ-706319	4-12x		
ED-327057	2-D8	EO-707663	2-L16	SA-706208	4-7		
ED-327057	2-D10	ER-341940	3-R100	SK-706202	5-7		

2. Model AM-U110

Parts No.	Ref. No. & Symbol No.	Parts No.	Ref. No. & Symbol No.	Parts No.	Ref. No. & Symbol No.	Parts No.	Ref. No. & Symbol No.
BA-706989	2-2	EJ-707043	3-25x	SK-707030	4-10		
BA-706990	2-3	ER-333015	2-R134	SK-707031	4-11X		
BA-706991	2-1	ER-333034	2-R307, 308	SK-707032	4-12		
BC-706981	4-3	ER-333043	2-R310	SK-707033	4-13x		
BC-706982	4-4x	ER-341329	2-R133	SK-707034	4-14		
BT-707006	3-16x	ER-341330	3-2x	SK-707035	4-15x		
BT-707007	3-17x	ER-341331	3-5x	SK-707036	4-16		
BT-707008	3-18x	ER-707001	2-R311	SK-707037	4-17x		
BT-707009	3-15	ER-707013	3-13x	SP-706977	3-31		
EC-684720	2-C310 to 313	ER-707014	3-14x	SP-706978	3-32x		
EC-707002	2-C308, 309	ER-707015	3-12	SP-706979	3-33x		
ED-200213	2-BD	ES-706995	2-SW1	SP-706980	3-34x		
ED-313623	2-D312	ES-706996	2-SW2	SP-707028	4-1		
ED-328486	2-D310, 311	ES-707010	3-10x	SP-707029	4-2X		
ED-336786	3-1x	ES-707011	3-11x	SZ-631945	3-27x		
EF-704515	2-F1, 2	ES-707012	3-9	ZG-707022	4-9x		
EF-704516	2-F1, 2	ET-245790	2-TR1	ZS-322570	4-18		
EF-704519	2-F3, 4	EV-706997	2-VR101	ZS-322580	4-19x		
EF-704521	2-F3, 4	EV-706998	3-6				
EF-707003	2-F1, 2	EV-706999	3-7				
EF-707004	2-F3, 4	EV-707000	3-8				
EI-213390	2-IC1	EW-707017	3-20x				
EI-704498	2-IC2	EW-707018	3-21x				
EJ-704538	3-26	EW-707019	3-22x				
EJ-706976	3-30	EW-707020	3-23x				
EJ-706992	3-3	EW-707021	3-19				
EJ-706993	3-4x	SK-706984	4-7				
EJ-707039	3-28	SK-706985	4-8x				
EJ-707041	3-29	SK-707025	4-5				
EJ-707042	3-24	SK-707026	4-6x				

SECTION 4

SCHEMATIC DIAGRAM

1. SCHEMATIC DIAGRAM OF ICs
2. AT-K110 NO. 1622439A SCHEMATIC DIAGRAM
3. AM-U110 NO. 1622438A SCHEMATIC DIAGRAM

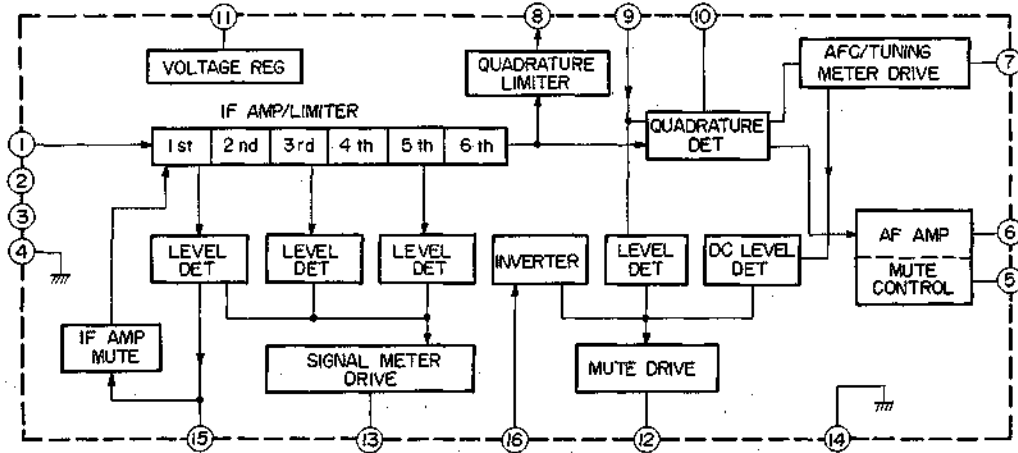

LA1231N

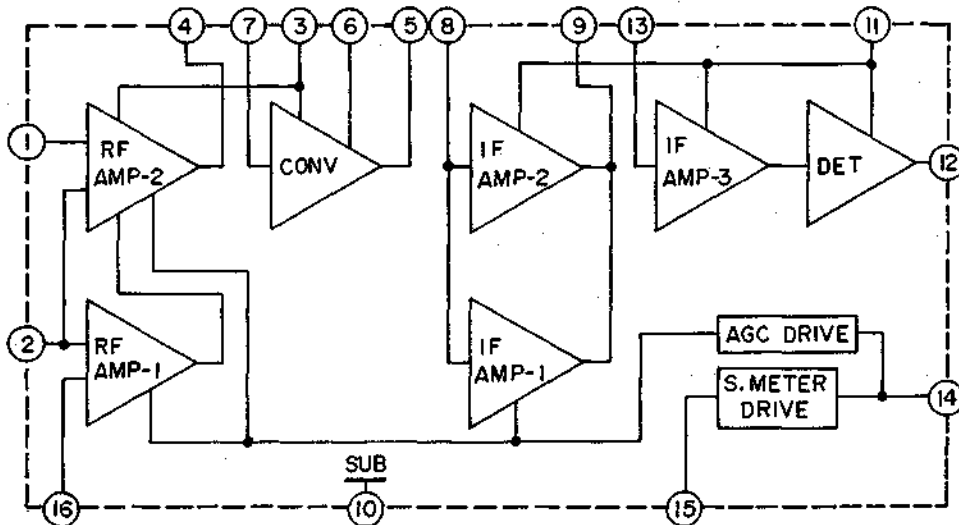

LA1240

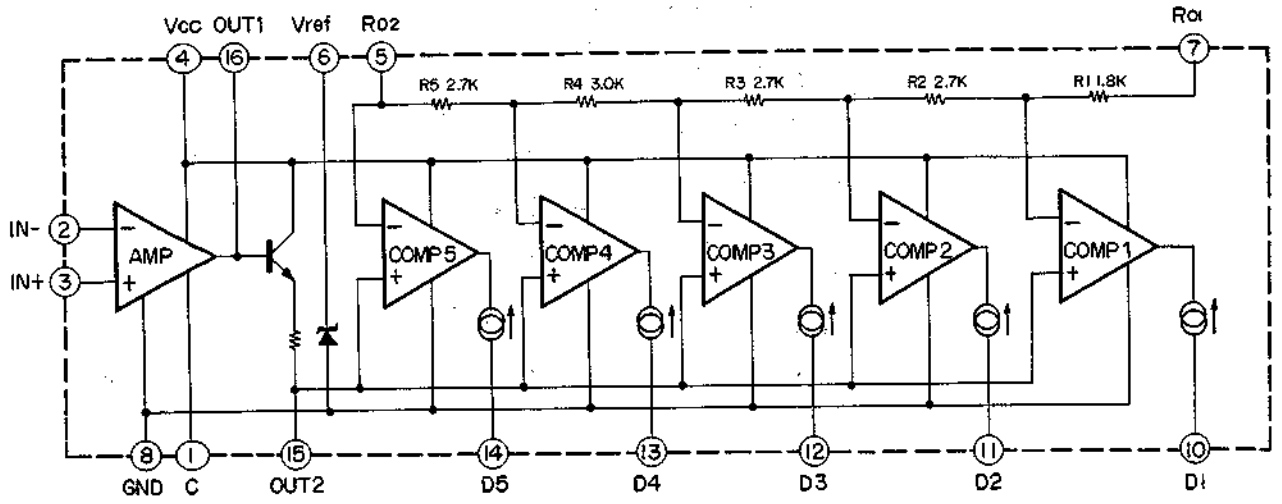

LB1415

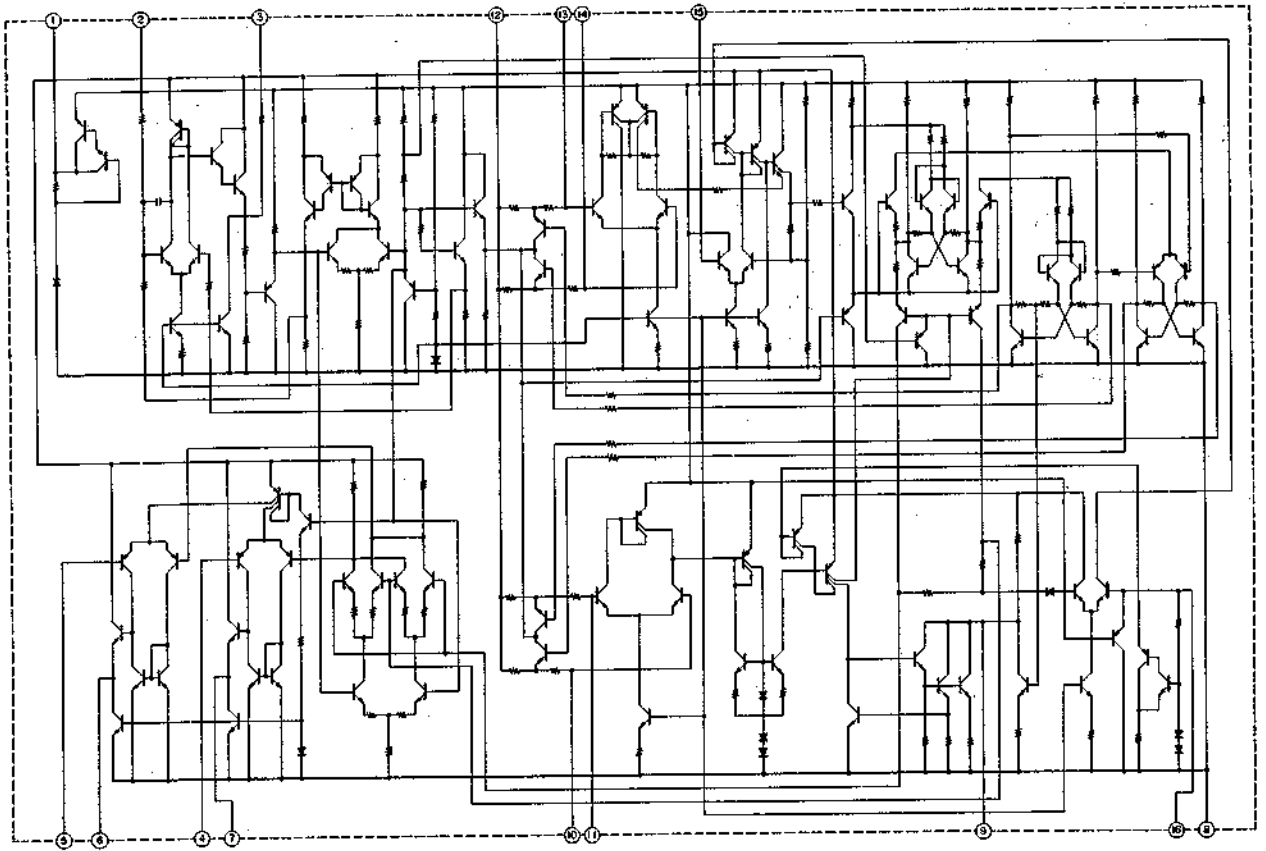

μPC1161C

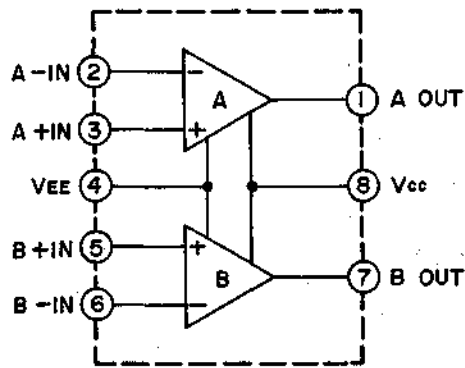

NJM4558DA

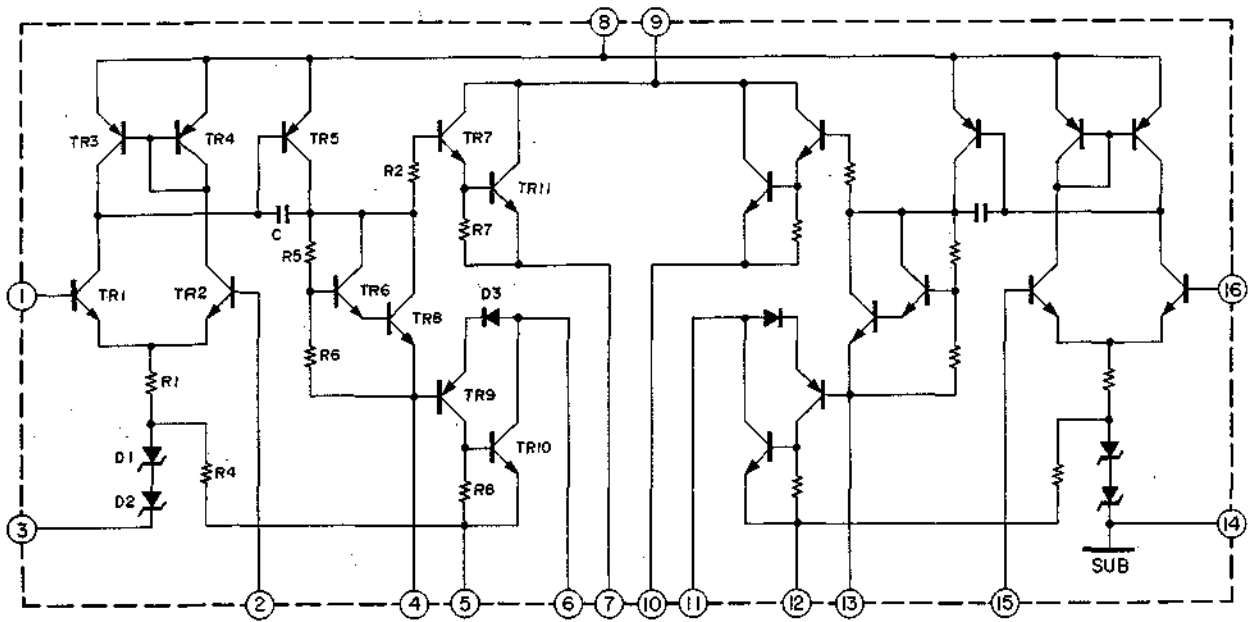

STK-461

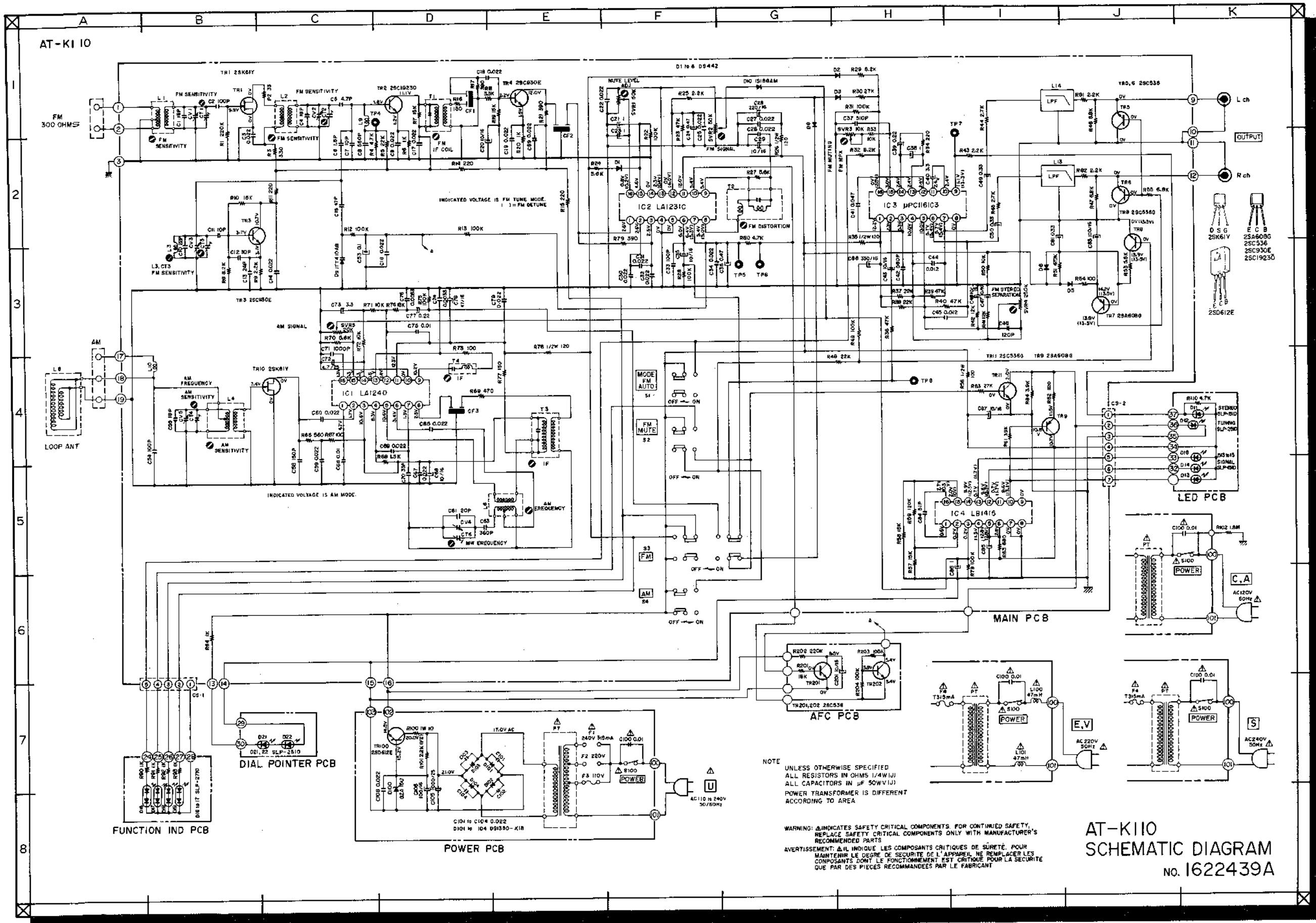

NOTE
 UNLESS OTHERWISE SPECIFIED
 ALL RESISTORS IN OHMS (1/4W/1J)
 ALL CAPACITORS IN µF (50WV/1J)
 POWER TRANSFORMER IS DIFFERENT
 ACCORDING TO AREA

WARNING: ⚠ INDICATES SAFETY CRITICAL COMPONENTS. FOR CONTINUED SAFETY,
 REPLACE SAFETY CRITICAL COMPONENTS ONLY WITH MANUFACTURER'S
 RECOMMENDED PARTS
 AVERTISSEMENT: ⚠ IL INDIQUE LES COMPOSANTS CRITIQUES DE SÛRETÉ. POUR
 MAINTENIR LE DEGRÉ DE SÛRETÉ DE L'APPAREIL, NE REMPLACER LES
 COMPOSANTS DONT LE FONCTIONNEMENT EST CRITIQUE POUR LA SÛRETÉ
 QUE PAR DES PIÈCES RECOMMANDÉES PAR LE FABRICANT

AT-K110
 SCHEMATIC DIAGRAM
 No. 1622439A