

Dual

Service Manual

1264

Edition January 1980



Technical data

Current	Measured values = typical values.
Line Voltage	Rumble and wow and flutter values obtained with test record.
Drive	AC 50 or 60 Hz, changeable by changing motor pulley
Power consumption	115 or 230 V, changeable
Starting Time	Dual 16-pole synchronous motor: flat belt for flywheel drive
Power Consumption	approx. 8 watts
Platter	(to each nominal speed) approx. 2 seconds at 33 1/3 rpm
Platter speeds	at 220 V, 50 Hz: approx. 75 mA
Pitch Control Variation	at 117 V, 60 Hz: approx. 140 mA
Speed control monitoring	Non-magnetic, detachable, 1 kg, 304 mm ϕ
Sensitivity of the strobe for 0.1 % speed deviation	33 1/3 and 45 rpm
Total Wow and Flutter	at both platter speeds
Rumble	Adjustment range at 33 1/3 rpm approx. 1 semitone (6 %)
Tonearm	with stroboscope for platter speeds 33 1/3 and 45 rpm,
Effective Length of Tonearm	adjustable to 50 or 60 Hz.
Offset Angle	6 division markings per minute at 50 Hz,
Tangential Tracking Error	7.2 division markings per minute at 60 Hz.
Tonearm Bearing Friction	DIN $\pm 0.07\%$
Stylus Pressure	WRMS $\pm 0.04\%$
Cartridges	Unweighted 48 dB
Weight	Weighted 70 dB

Torsion-resistant tubular aluminium tonearm in four-point gimbal bearing
221 mm
24° 4'
0.16°/cm

vertical	0.07 mN (0.007 g)
horizontal	0.15 mN (0.015 g)

from 0 – 30 mN (0 – 3 g) infinitely variable with 1 mN (1/10 g) calibrations
from 0 – 15 mN (0 – 1.5 g) operable from 5 mN (0.5 g) stylus pressure up
with 1/2 inch screw-type attachment. These can be fitted with the special
accessories no. 262 186 which can be obtained from trade dealers.

Table of Contents

Page	
1	Specification
3	Motor and drive
3	Speed selection
3	Turntable
3	Belt
3	To replace the motor pulley
4	Stroboscope
4	Tuning to the pitch-of-tone level
4	Tone arm with bearings
4	To remove tone arm complete with bearings
5	To remove the tonearm or the spring housing
5	To adjust the tonearm bearings
5	Fitting 1/2 inch pick-up
5	Anti-skating device
5	Tone arm lift
5	To replace the lift plate
5	Tone arm control
6	The starting sequence
6	Manual start
6	Continuous play
6	Muting switch
6	Stopping
7	Shut-off and change cycle
7	Record drop
7	Shut-off mechanism
7	Adjustments
7	Tone arm set-down point
7	Set-down point for 30-cm records
7	Set-down point for 17-cm records
7	Shut-off point
8	Tone arm lift height
8	Tone arm improperly lowered
8	Rated speed borders pitch adjustment range
8	Turntable does not start
8 – 11	List of spare parts and Exploded view
12	Lubrication

Fig. 1 Pick-up Connection Diagramm

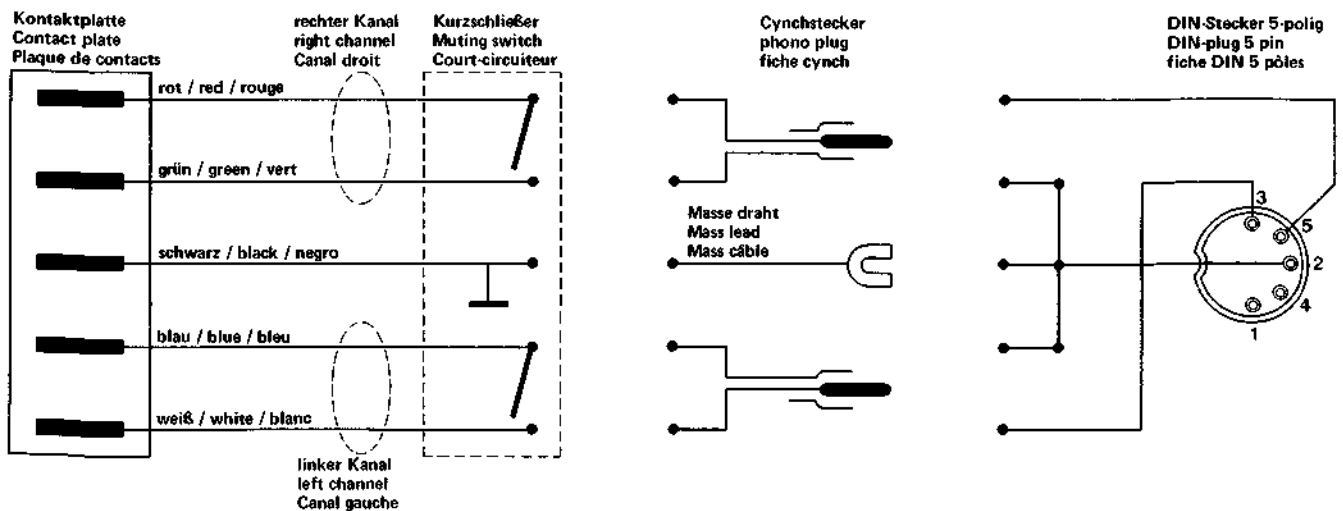

Motor and Drive

Turntable and mechanism are driven by the motor **130**. This shaded-pole motor runs vibration-free in radially elastic mounts and has extremely low magnetic leakage.

The motor speed is independent of voltage, temperature, and load variation. It can only fluctuate with the mains frequency. Two motor pulleys permit adaptation to the mains frequency of either 50 or 60 Hz; one pulley **116** is shown in both Fig. 2 and Fig. 3.

For 50 Hz use the pulley part no. 261 938,
for 60 Hz use the pulley part no. 261 939.

The driving force is transmitted to the turntable **14** by belt **17**.

Speed Selection

To adjust the turntable speed to either 33 1/3 or 45 rpm, the belt **17** is shifted to the one step of pulley **116** with the associated diameter (see Fig. 3). This is achieved when you adjust the speed lever **20** so that the START/STOP lever and the spring lever will move the change-over lever into the desired (33 or 45 rpm) position. When the record player is turned off, the changeover lever is blocked by the blocking bar and the speed is just preselected. Only when the turntable **14** starts running, the blocking bar **8** will release the change-over lever. The latter will then shift the belt **17** to that step of motor pulley **116** which corresponds to the desired speed.

Platter

The platter is secured to the securing disc **5** by the bayonet catch. When removing the platter **14** press the securing disc lightly downwards and turn it approximately 60° to the right until it is felt to click out of position.

Belt

To replace the belt **17**, first remove the turntable as above described, then separate the belt from the turntable **14**. Mount the new belt on the turntable.

NOTE: the ground (mat) surface of the belt should face the driven part. Install the turntable and place the belt **17** over the motor pulley **116**.

To Replace the Motor Pulley

1. Separate the belt **17** from pulley **116** and remove the turntable. Remove the toothed belt **109**.
2. Disengage the tension spring **114** from the shield **122**.
3. Unscrew the hex. nut **111**, remove the setting cam **112**, belt pulley **113**, and counter bearing **114**.
4. Slacken the grub screws **117** and slide off the motor pulley **116**. Slide the replacement pulley onto the motor shaft. Remove the taper sleeve. Pay attention on the internal distance spring. Position the motor pulley **116** at proper height above the mounting plane, see Fig. 3. Uniformly tighten the grub screws **117**. Put the taper sleeve into the motor pulley **116**.
5. Mount the counter bearing **114**, the belt pulley **113** and the setting cam **112** and secure them in place with hex. nut **111**. Install the tension spring **122** and the toothed belt **109**.
Mount the turntable. Pull the belt **17** and place it around the motor pulley **116**.
6. Turn the knob **18** to adjust the belt pulley **113** to its mid position. (The nose of the belt pulley **113** should point to the motor pulley center line.) Adjust the hex. nut **111** to the rated speed; the speed increases when you turn the nut clockwise and vice versa.

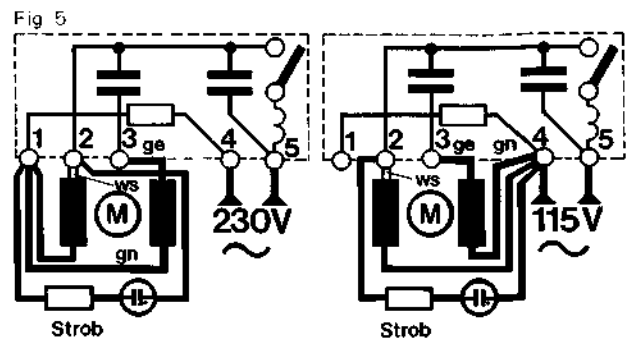
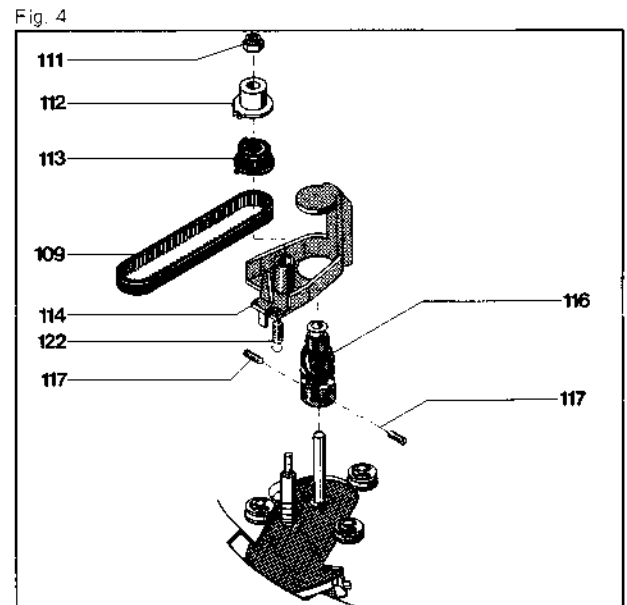
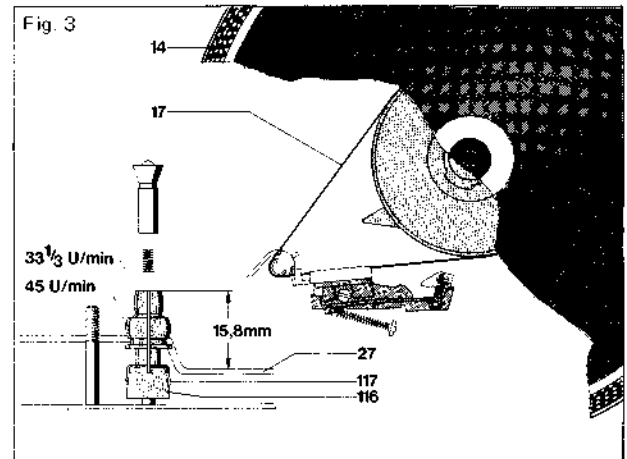
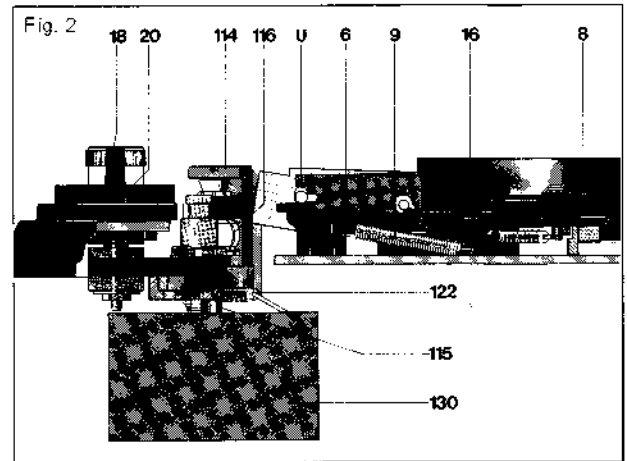

Fig. 6

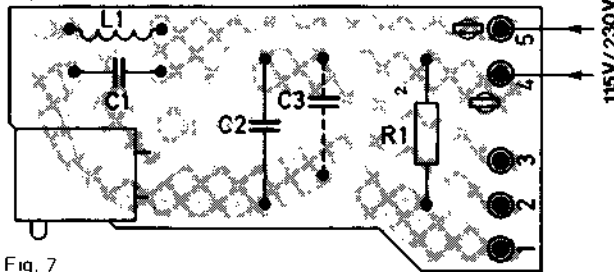

Fig. 7

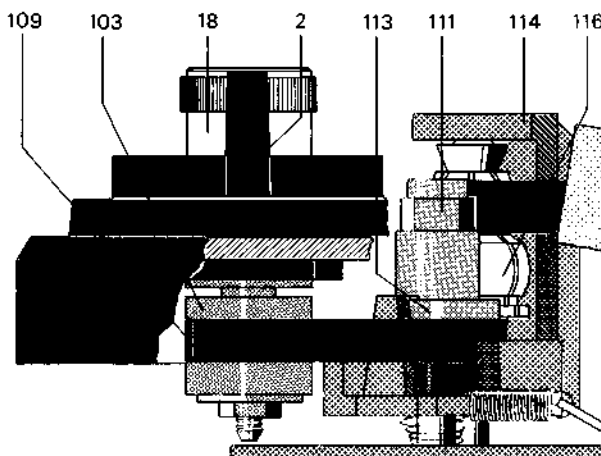

Fig. 8

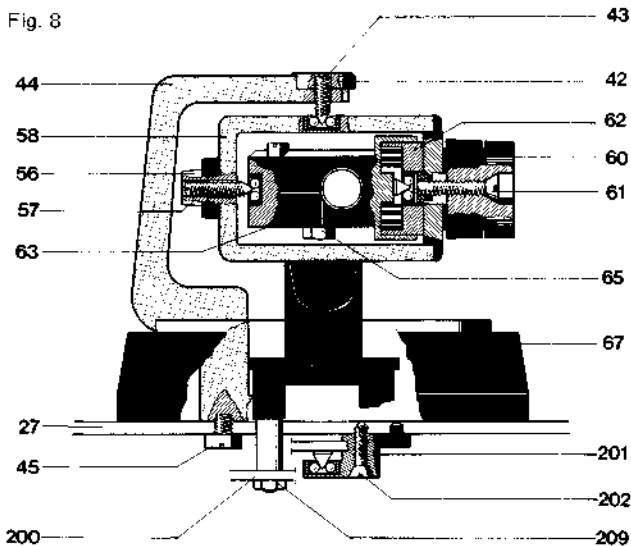
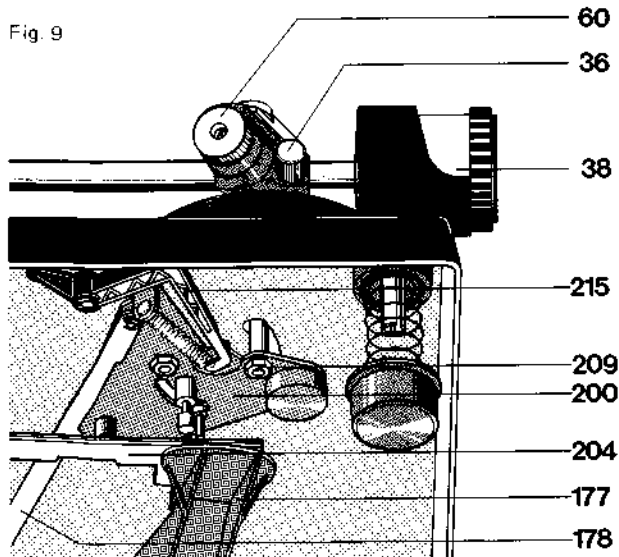

Fig. 9



Stroboscope

Even during the play mode the stroboscope can be used to check the accuracy of the turntable speed adjustment to 33 1/3 and 45 rpm.

Accurate adjustment is manifested by seemingly motionless bar marks of the stroboscope. If the marks run in the same direction as the turntable, the speed is too high and vice versa.

To vary the adjustment, operate the "pitch" knob 18. The strobo marks on the turntable rim, have the following meanings (starting from the lowest row): 33 1/3 rpm at 60 Hz, 33 1/3 rpm at 50 Hz. To exchange the glow lamp G1 131, remove the screws 234 and the strobo case.

Pitch Control

This feature is independent of the power and controls both turntable speed. The tuning range is max. 6 % or about one semi-note.

When you rotate the knob 18, you will move the belt pulley 2 105. This motion will be transferred by the toothed belt 109 to the belt pulley 1 113. As a result, the counter bearing 114 and taper sleeve of motor pulley 116 are shifted upwards or downwards, respectively. The taper sleeve of the motor pulley 116 causes the pulley diameter to be reduced or increased, which permits the variation of the rated speed within the said range of $\pm 3\%$.

Tone Arm with Bearings

The light-weight torsion-resistant aluminum-tube tone arm has a universal gimbal bearing characterized by four hardened and lapped steel points located in high-precision ball bearings. The tone-arm bearing friction is thus reduced to a minimum, namely

less than 0,07 mN or 0,007 gr in vertical and less than 0,15 mN or 0,015 gr in horizontal direction, referred to the stylus point.

This ensures particularly satisfactory tracking conditions. Before adjusting the tracking force, which should comply with the pick-up system used, adjust the tone arm to its balanced position while the tracking-force scale indicates zero.

The tracking force is produced by tensioning the helical spring located in the spring case 62. The rotary turn knob 60 has a scale with marks permitting exact adjustment of the tracking force within the range 0 – 30 mN (or 0 – 3 gr).

To Remove the tonearm complete with the tonearm bearing

We recommend the following procedure:

1. Secure the unit in a repair stand. Turn the rotary turn switch 60 to the zero position. Lock the tonearm 38. Remove the counter-weight 55.
2. Adjust record player to head position. Remove the shield 160. Unsolder the tone-arm leads from muting switch.
3. Remove the main lever 177. Remove the lock washer 242. Rotate the set screw 26 until guide bearing 241 and setting ting bar 228 come free. Remove lock washer 228 and setting bar 204.
4. Unlock the tension spring 212, loosen the lock washer 216 and remove skating lever 215.
5. Remove lock washer 202 from segment 200.
6. Remove hex. nuts 209 and the screw 202. Remove the bearing 201 and the segment 200.
7. Grip the frame 44 and the tonearm 38. Loosen the machine screw 45 and take off the tonearm and frame.

Reassembly of the tonearm involves the reverse procedure. Take care that the grub screw 43 is correctly seated in the bearing when when fastening the frame 44.

To Remove the tonearm or the spring housing

1. Secure the unit in a repair stand. Turn the rotary turn switch **60** to the zero position. Lock the tonearm **38**. Remove the counterweight **55**.
2. Turn the unit cover. Remove the screening sheet **160** and solder off the tonearm connections at the muting switch. Turn the unit the right way up.
3. Remove the fillister head screw **61**. Remove the rotary turn switch **60** and the washer **59**.
4. Loosen the nut **56** and the grub screw **57**. Draw the tonearm **38** complete with bearing **63** from the bearing race **58**. The spring housing **62** or the tonearm **37** may now be changed.

Reassembly involves the reverse procedure.

To Adjust the Tone Arm Bearings

Exactly balance the tone arm. Both bearings should have a small, just perceptible backlash or play. Proper adjustment of the horizontal bearing is achieved if the tone arm can freely slide from the record inside to outside while the anti-skating adjustment is 0.5. Proper adjustment of the vertical bearing is achieved when the carefully kicked tone arm swings into balanced position. Adjust the backlash by grub screws **43** and **57** for the horizontal and vertical bearing, respectively.

Fitting a 1/2 inch cartridge

If a cartridge with 1/2 inch standard mount is to be fitted, the conversion kit Number 262 186 is necessary. The proper method of fitting is shown in fig.

Also the decorative cover should be removed from the counterweight **55** and should be fitted with the compensatory weight to be found in the conversion kit **41**.

Coarse adjustment is carried out by moving the weight with stem **38** subsequent fine adjustment by turning the front knurled ring on the weight.

Anti-Skating Device

To adjust the anti-skating force, operate the pointer scale provided on the cover **69**. Depending on this adjustment, the skating lever **215** will be deflected from the tonearm pivot point. The anti-skating force is transmitted by the tension spring **212** to the segment **200** and thus to the tonearm **37**.

The factory adjustment is optimal for any stylus having a spherical tip radius of 15 μm or elliptical of 5 – 6 and 18 – 22 μm .

These factory-adjusted values may be varied only in an authorized Dual service workshop using a Dual Skate-0-Meter and a test record.

Tone Arm Lift

When you move the lift control bar **218** to the LIFT position ∇ , the tone arm will be lifted and in position LOWER ∇ it will be lowered through the lift cam **219** and the setting bar **204**. The tone arm lift has priority over the set-down mechanism. When the record player is started with the control bar **218** in the LIFT position ∇ , the set-down mechanism will move the tonearm across the record in the auto mode. Lowering of the tonearm will take place only after you have adjusted the control bar **218** to the POWER position ∇ .

The height of lift should be 3 to 5 mm; it can be adjusted by the setscrew **26**.

To Replace the Lift Plate 158

1. Remove the main lever **177** and the lock washer **242**. Rotate the setscrew **26** until guide bearing **241** and setting bar **204** are released. Remove lock washer **228** and setting bar **204**.
2. Unhook the tension spring **212**.
3. Remove lock washer **206** and disk **205**. Detach the shut-off bar **179** from segment **200**.
4. Remove hex. nuts **202** and the screw **202**. Remove the segment **200** and the bearing **201**.
5. Remove the screws **198** and the lift plate **199**.

To reassemble, proceed in reversed order.

Fig. 10

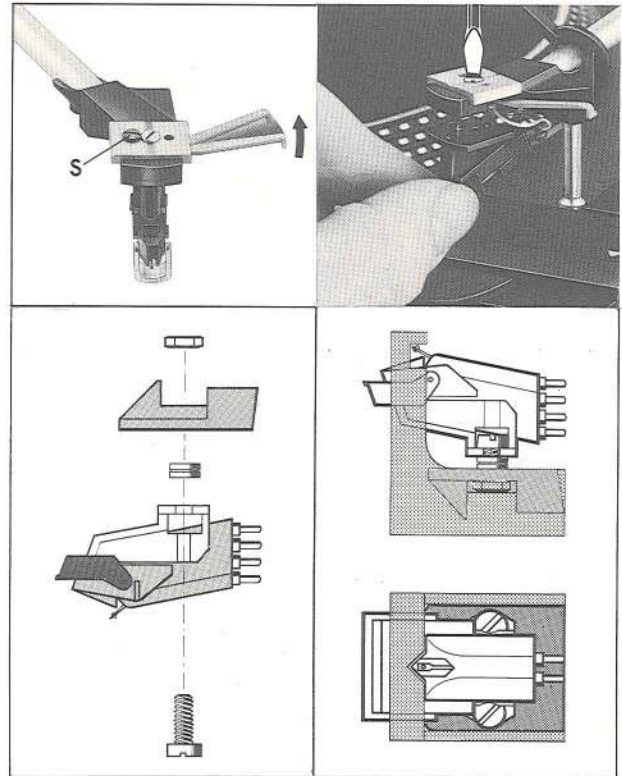
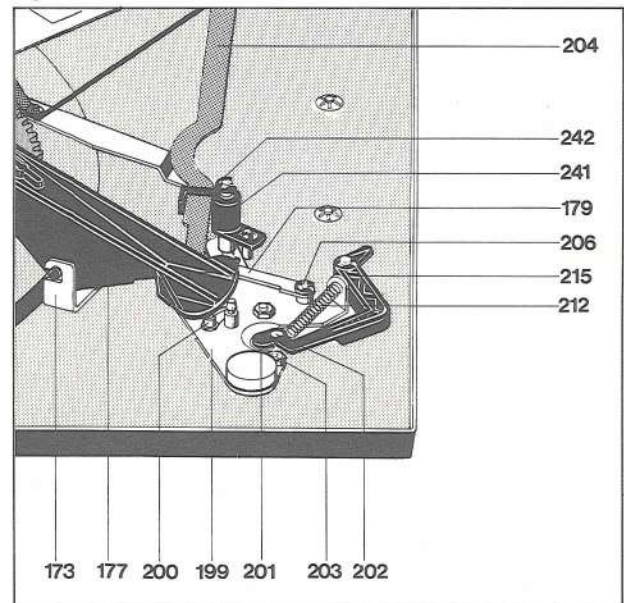

Fig. 11



Tone Arm Control

The tonearm motions for auto lowering and lifting are controlled by cams under the cam wheel **161** while the wheel rotates through 360°.

Lifting and lowering motions are controlled by the main lever **177** and lifting bolt while the horizontal motions of the tonearm are controlled by lever **177** with the segment **200**.

The lifting/lowering mechanism is active for 30 cm- and 17 cm-records, it is coupled to the turntable-speed change-over function. The tonearm set-down points are determined by the spring pin of segment **200** abutting against the setting bar **204**. The horizontal motion is limited by the segment abutting against the setting bar **204** which is lifted only during the set-down operation by the main lever **177** and thus comes into the sluing range of the spring pin provided on the segment.

Fig. 12 U AW AK 186 204 179

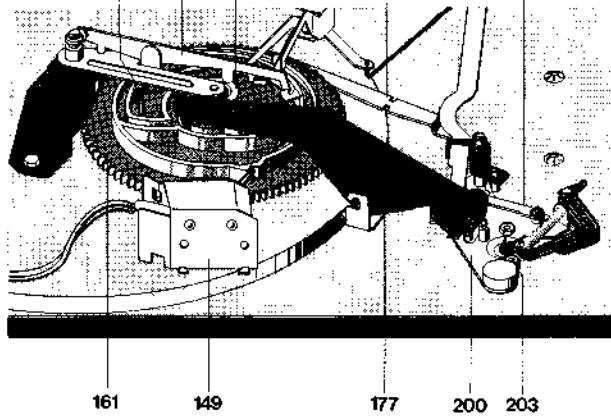

After the tonearm has been set down on the record, the setting bar **204** is released and returns to its normal position, thus escaping from the range of the spring pin. The tonearm is thus free to move in horizontal direction during the play-back.

The Starting Sequence

When you adjust the START/STOP lever to the START position, the turn-on lever **207** is rotated to the outside and will trigger the following functions:

- The turn-on lever **207** rotates the shift links **189** seated on the ruffled pins **183**. At the same time, the power switch is turned on **135** and both the motor **130** and turntable start rotating.
- The shift link **189** enters the range of the reversing lever which is forced into its start position by the subsequent rotation of the cam wheel **161**.
- Operation of the START/STOP lever **50** will also release the start angle **187** that is pulled towards the cam wheel by the tension spring **188**. The shut-off lever is thus brought into the range of dog M on the turntable pinion (PR) and the cam wheel is driven.

Fig. 13

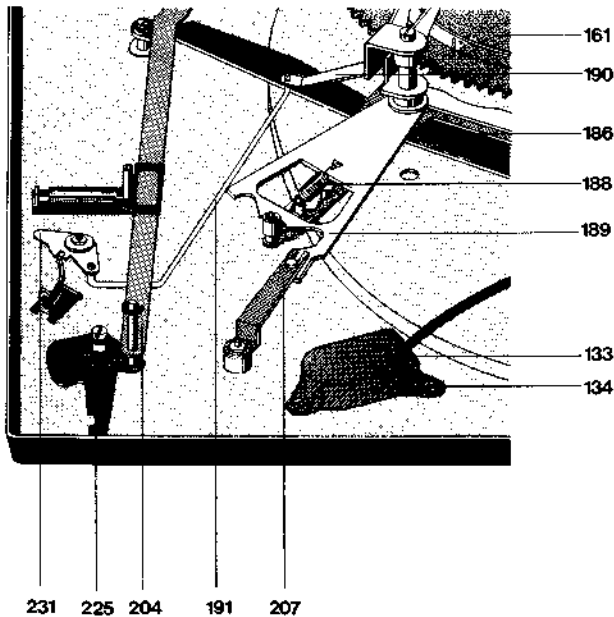

Manual Start

When the tonearm is guided towards the record manually, the pawl **236** coupled to the shift arm **165** will engage with the square bolt mounted in the deck plate and will keep the shift arm in this position. Coupled to the shift arm is the shut-off lever **168** that will turn on the power switch and thus initiate the turntable rotation. When the run-out groove of the record played has been reached, the tonearm is restored and the record player is turned off by automatic means. If you lift the tonearm before the end of play and put it back onto its support, the bolt of segment **200** will release the engaged position of the pawl **236** so that the shift arm is returned to its initial position and the power switch will turn off.

Continuous Play

This mode is operative when you have adjusted the knob **66** to ∞ . The knob **66** will rotate the reversing angle **231** and the latter is forced into the starting position by the turn-on lever **207** at the end of record, the tonearm is restored to its rest position on the support near the record rim. This procedure will be repeated until the START/STOP lever **50** is adjusted to STOP or the knob **66** is adjusted to no. 1 position.

Muting Switch

The muting switch is provided to avoid noisy lifting and lowering of the tonearm in the auto made. The contact springs of both channels are controlled by the cam wheel. The resulting short-circuiting of the pickup leads is ineffective in the rest state of the record player.

Fig. 14

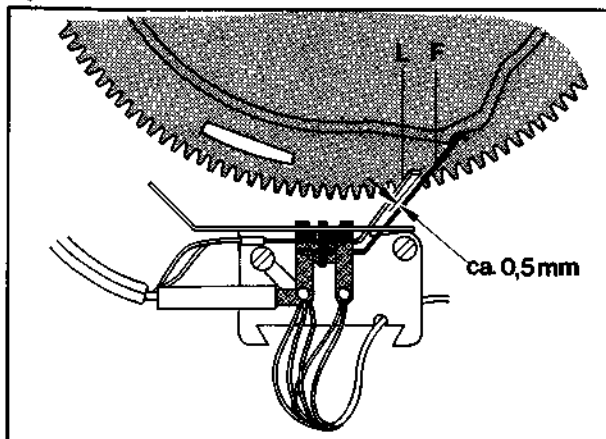

Adjustment

In the zero position of the cam wheel, a contact separation of about 0.5 mm should exist between the contact springs (**F**) and the shorting straps (**L**) in Fig. 14. If necessary, bend the shorting straps. Maintain contact springs in good state by a spraying agent.

Stopping

When control lever is set to "stop" position the start lever which is pulled towards the cam by means of tension, is free. As a result, the shut-off lever is moved into the range of dogs cam. The guide lever remains in its stop position.

Shut-off and change cycle

Shut-off and change functions are determined by the position of the guide lever **U**. After every start or record drop, the guide lever is brought to its stop position by the main lever (longer end towards the center of the main cam). As the record is dropped the guide lever **U** is turned to its start position by the cam rocker, so that the tonearm can swing in toward the record and be lowered on to it. If there are no more records on the spindle, and the cam rocker cannot turn the guide lever, the lever remains in its stop position and allows the tonearm to swing to its rest position. When the main cam wheel **161** returns to its neutral position, the switch arm **165** drops into a cut-out in the main cam, opening the power switch **135** and disengaging the drive idler.

Record drop

Insert the changing spindle – AW 3 for standard records (7 mm or 1/4" center hole) or AS 12 for 45 rpm records (38 mm or 1 1/2" center hole).

The record drop is initiated by the cam wheel **161** whose drop cam surface **AK** controls the release rocker **AW** and the changer actuator rod.

Adjustment

Release rocker

The eccentric screw (c) is used to alter the travel of the changing bolt **168**. The setting is correct when at the rest position of the cam wheel **161** and with interlocked changer spindle, the changing bolt **168** has a travel of 0.2 mm.

Shut-off mechanism

The dog **M** on the turntable platter gear **PR** and the shut-off lever **A** actuate both the change cycle at the end of the record as well as the shut-off after the last record in a stack is played. The shut-off bar **179** is guided along in proportion to the movement of the segment **200**.

The shut-off procedure is initiated after a record has been played by the dog **M** of the platter and the shut-off lever **A**.

The shut-off lever **A** is moved towards the dog **M** of the platter within the shut-off range (record diameter 116 mm to 122 mm). The dog engages the shut-off lever **A**. The cam wheel **16** is moved from 0 position and engage with the drive pinion of the platter.

The main lever **177** guides the tonearm back and effected the tonearm to return to its rest position.

Adjustments

Tone Arm Set-down Point

Slightly pry up the nameplate „Dual“ at its lower left corner and swivel it outwards (Fig. 18). The now accessible opening will show one of the adjusting screws.

Set-down Point for 30-cm Records

Adjust the speed selector **20** to the "45" position and correct adjustment with a screwdriver. If the stylus sets down too far on the record inside, rotate the adjusting screw clockwise. If the stylus is lowered outside the 30 cm-record, rotate the screw counter-clockwise.

Set-down Point for 17-cm Records

Adjust the speed selector **20** to the "33" position and rotate the screw as above described for adjustment.

Fig. 15

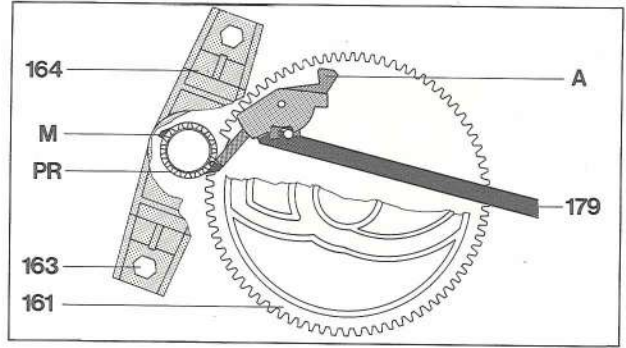

Fig. 16

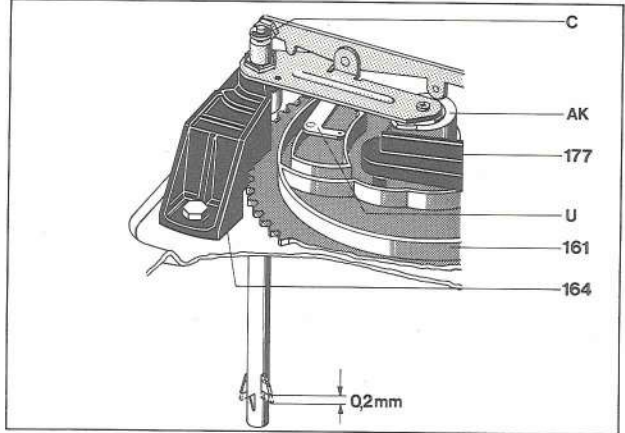
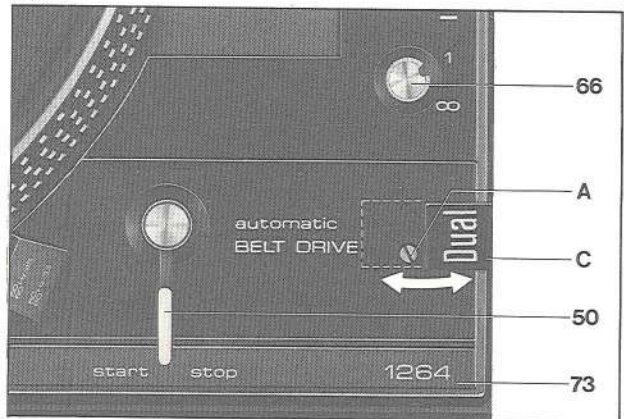

Fig. 17



Shut-off Point

In the shutting-off range for records 116 – 122 mm in diameter, the excenter **S** on segment **200** can be used to vary the shut-off point.

Fig. 18

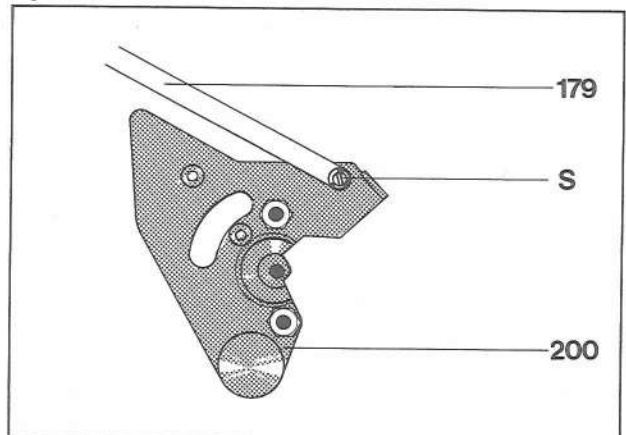
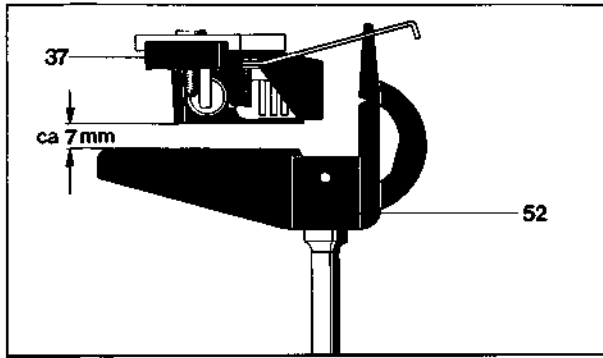

Fig. 19



Tone Arm Lift Height

This height of the auto mode can be adjusted with the aid of the setting sleeve **197**. Pull the mains plug. Disengage the tone arm. Rotate the cam wheel **161** out of its zero position until the tone arm has reached its greatest lift height. The height above the tone arm support stop should be about 8 mm as shown in Fig. 19. If necessary, rotate the setting sleeve **197** clockwise or anticlockwise as required.

Defect

Tone arm improperly lowered (too fast or not on record).

Cause

Shock-absorbing action of silicone oil in lift tube is excessive or insufficient.

Repair

Demount the lift plate **199**, remove the control stud **195**, lock washer **196**, and setting sleeve **197** with lock washer; remove lift bolt and pressure spring, clean lift tube and lift bolt. Evenly apply WACKER SILICONE OIL AK 500 000 to the lift bolt. Reassemble the parts.

Rated speed borders pitch adjustment range.

Positioning of belt pulley is inaccurate.

Adjust knob **18** to mid position; adjust hex. nut **111** to rated speed (clockwise adjustment will increase the speed and vice versa).

Turntable does not start.

- a) Belt is not in place.
- b) Motor is not powered.
- c) Motor pulley has come loose.

- a) Mount the belt.
- b) Check switch base and mains plug.
- c) Tighten it.

Replacement parts

Pos.	Part.-No.	Qty	Description
1	215 470	1	Automatic Spindle
2	213 895	1	Change spindle
3	220 213	1	Centering piece
4	261 910	1	Idling pin
5	263 395	1	Lock washer complete
6	261 914	1	Mount complete
7	248 346	1	Pressure spring
8	261 916	1	Locking rail compl.
8	264 027	1	Locking rail compl.
9	249 171	1	Tension spring
10	248 347	1	Tension spring
11	260 157	1	Stop
12	263 950	1	Platter mat
13	248 893	1	Spring washer
14	263 951	1	Platter complete
15	200 543	1	Snap spring
16	263 399	1	Fly wheel rotor complete
17	261 921	1	Flat belt
18	260 461	1	Regulating knob
19	232 078	1	Bearing bush
20	260 297	1	Speed lever
21	263 378	1	Speed cover
22	213 260	4	Grooved drive stud
23	210 194	1	Grip ring
24	210 472	1	Machine screw
25	234 599	1	Reset cam
26	240 069	1	Adjusting screw
27	263 400	1	Mounting plate complete
30	237 228	2	Spring suspension
	234 433	2	Spring suspension (motor side)
31	230 529	1	Threaded coupling
32	236 712	2	Pressure spring
	232 843	2	Pressure spring (motor side)
33	200 723	4	Rubber absorber

Pos.	Part.-No.	Qty	Description
34	200 722	4	Casing
35	239 414	3	Transport lock
36	260 428	1	Clamping
37	263 262	1	Tonearm complete
38	263 401	1	Weight complete
	263 983	1	Weight complete (UAP)
39	263 259	1	Tonearm head complete
40	261 929	1	Tonearm lead
41	262 186	1	1/2 inch conversion kit complete
42	249 383	1	Counter nut
43	234 651	1	Grub screw
44	261 979	1	Frame complete
45	242 677	1	Machine screw M 4 x 8
48	236 069	1	Machine screw
49	248 979	1	Lifting plate
50	260 298	1	Switch lever
51	260 328	1	Stroboscope prism
52	263 408	1	Tonearm rest complete
56	246 864	1	Conter nut
57	234 634	1	Grub screw
58	261 981	1	Bearing race complete
59	261 798	1	Washer 5,2/10
60	248 989	1	Rotary knob
61	249 097	1	Raised countersunk head screw M 2,5 x 12
62	263 331	1	Spring housing complete
63	263 330	1	Bearing complete
64	210 597	1	Washer
65	262 294	1	Screw
66	260 334	1	Rotary knob
67	263 407	1	Rear cover
68	200 444	7	Spring washer
69	260 320	1	Cam disc
70	242 298	1	Washer

Fig. 20 Exploded view 1

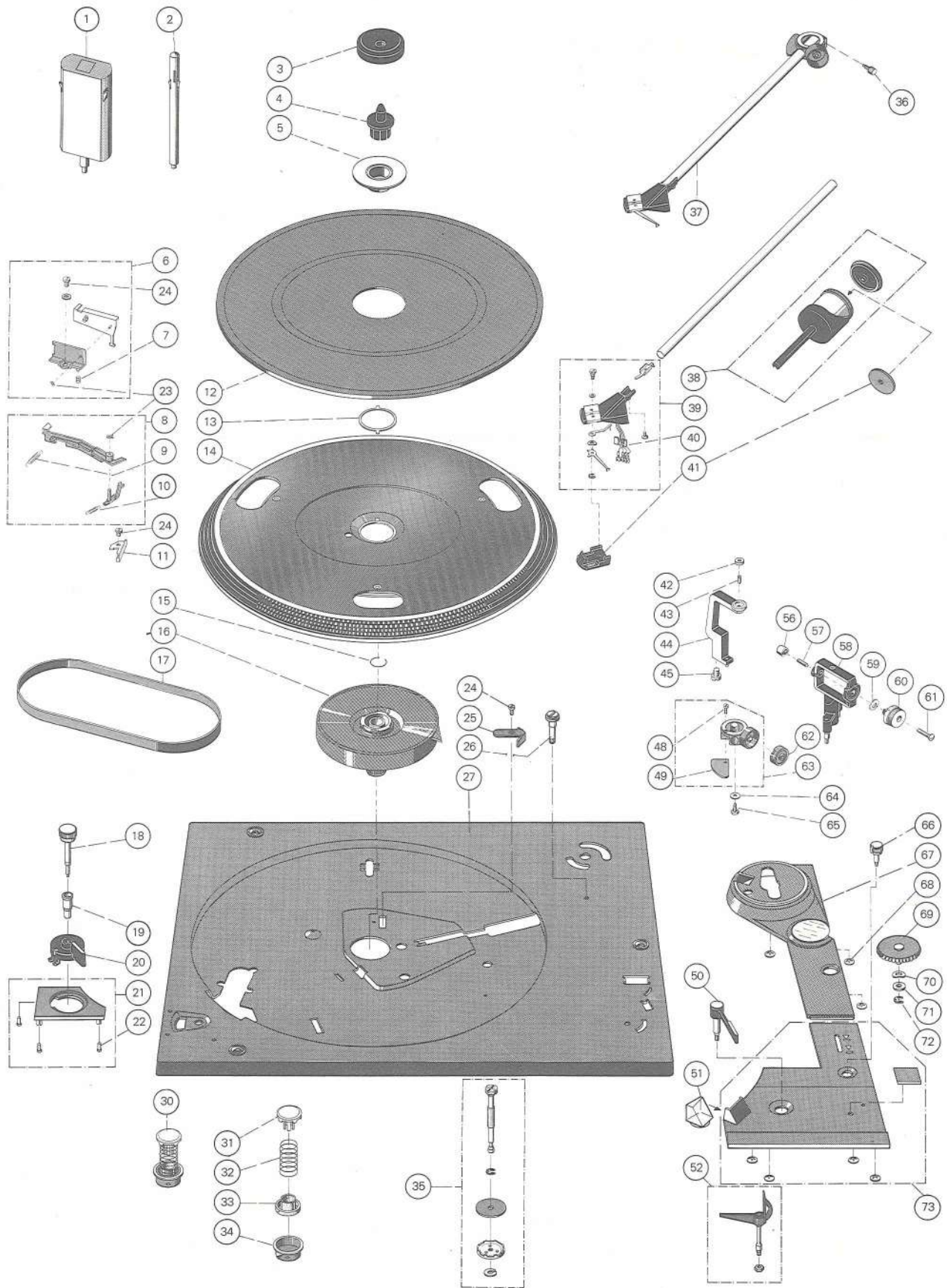
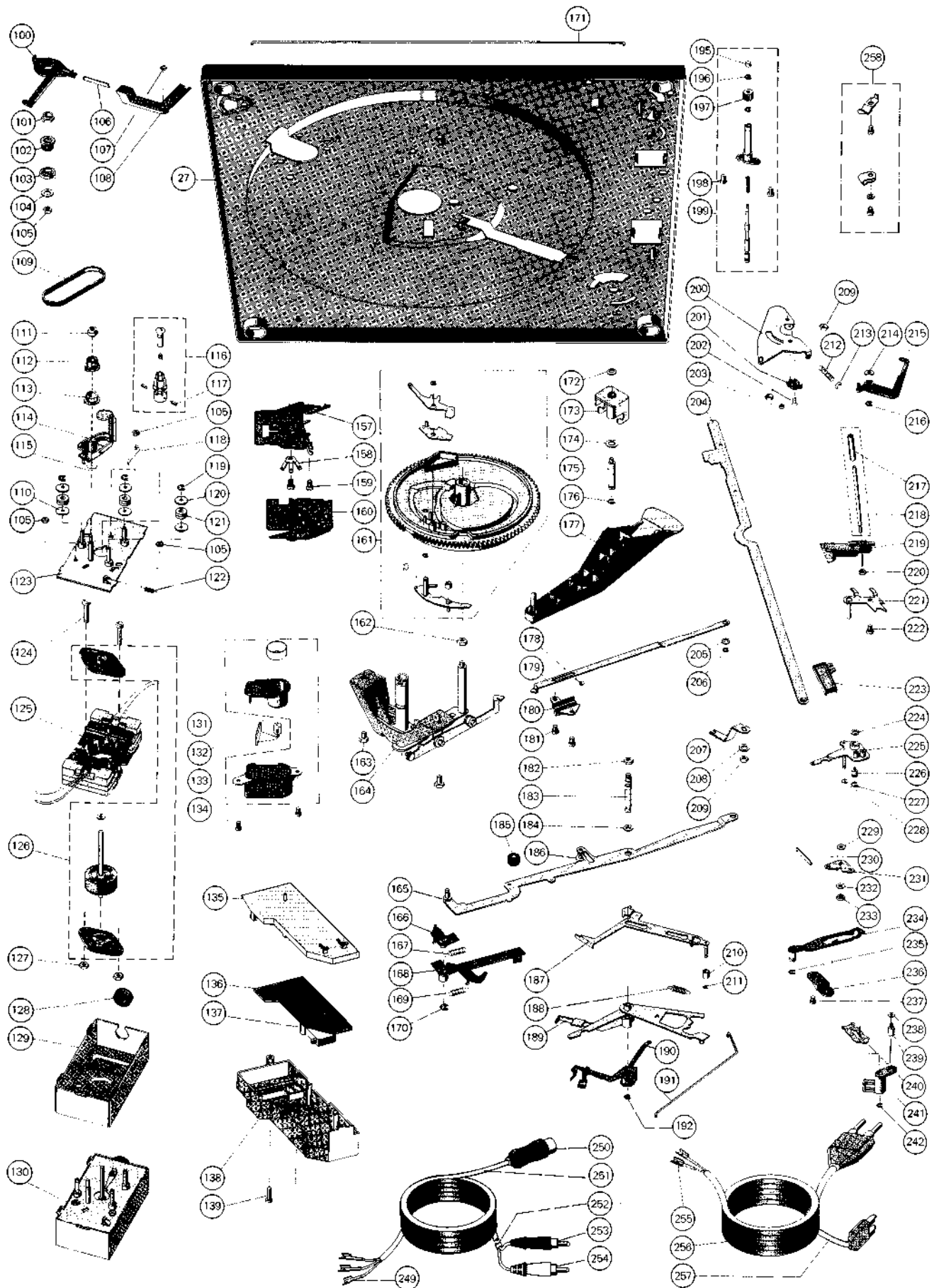

Fig. 21 Exploded view 2



Pos.	Part-No.	Qty	Description
71	228 113	1	Washer 4,2/8/1
72	210 146	1	Lock washer 3,2
73	263 953	1	Font cover complete
100	260 537	1	Connection part
101	232 079	1	Shouldered nut
102	232 097	1	Belt wheel
103	240 035	1	Washer
104	210 607	1	Washer 3,2/10/0,5
105	210 362	1	Hex nut M 3
106	260 570	1	Clip spring
107	210 196	1	Grip ring
108	260 475	1	Switch lever
109	260 309	1	Toot hed belt
110	210 607	3	Washer 3,2/10/0,5
111	244 104	1	Hex nut
112	241 641	1	Control curve
113	241 642	1	Belt wheel 1
114	248 508	1	Conter bearing
115	232 615	1	Presure spring
116	261 938	1	Motor pulley 50 Hz
	261 939	1	Motor pulley 60 Hz
117	233 137	1	Grub screw
118	247 920	1	Earth bracket
119	210 145	3	Lock washer
120	210 609	3	Washer
121	249 182	3	Damping sleeve
122	233 777	1	Tension spring
123	261 121	1	Motor plate
124	248 335	2	Machine screw
125	261 944	1	Stator 110/200 V kpl.
	261 946	1	Stator 110/220 V kpl. UI/CSA
126	261 945	1	Armature with bearing complete
127	222 200	2	Hex nut M 3,5
128	209 939	1	Rubber bush
129	247 858	1	Screening plate
130	261 961	1	Motor SM 100-1 compl.
131	260 421	1	Glow lamp
132	249 092	1	Switch plate
133	263 336	1	Stroboscope housing complete
134	210 469	1	Machine screw
135	260 137	1	Housing
136	261 965	1	Switch plate
137	262 272	1	Power switch
C 1	241 646	1	10 nF/250 V/20 %
C 2	249 352	1	0.33 μF/250 V/10 %
C 3	230 355	1	68 nF/250 V/20 %
R 1	249 354	1	5.1 kΩ/5 W/5 %
L 1	242 822	1	RF cocke 47 μH
138	248 881	1	Cover
139	210 491	1	Machine screw
157	236 402	1	Muting switch
158	239 562	1	Soldering lug
159	210 472	2	Machine screw
160	232 084	1	Screen sheet
161	236 912	1	Cam wheel complete
162	210 366	1	Hex nut
163	218 155	2	Hex screw
164	263 965	1	Bearing bridge complete
165	234 542	1	Switch arm
166	248 878	1	Switch lever
167	260 363	1	Tension spring
168	260 387	1	Switch off lever
169	229 686	1	Tension spring
170	210 145	1	Lock washer 2,3
171	234 592	1	Connection rod
172	210 587	1	Washer 3,2/7/1
173	234 677	1	Bearing bracket
174	210 667	1	Washer 5,3/10/0,5
175	234 676	1	Screw bolt
176	210 147	1	Lock washer 4
177	236 914	1	Main lever
178	211 718	1	Ball 5 3
179	234 668	1	Stop rail
180	234 558	2	Ball bed
181	210 472	2	Machine screw M 3 x 4

Pos.	Part-No.	Qty	Description
182	210 362	1	Hex nut M 3
183	234 544	1	Groove bolt
184	210 586	1	Washer 3,2
185	236 950	1	Stop bush
186	239 931	1	Roller
187	234 545	1	Start angle
188	229 698	1	Tension spring
189	244 784	1	Switch crank
190	234 555	1	Switch over lever
191	234 598	1	Connection rod
192	210 146	1	Lock washer 3,2
195	216 844	1	Control nipple stud
196	210 143	3	Lock washer 1,5
197	218 318	1	Adjustable adapter
198	210 472	2	Machine screw M 3 x 4
199	263 402	1	Lift plate complete
200	263 403	1	Segment
201	242 615	1	Counter bearing
202	203 475	1	Counter sunk screw M 3 x 8
203	223 777	1	Control nipple stud
204	240 060	1	Slide rail
205	201 187	1	Sliding washer
206	210 145	4	Lock washer 2,3
207	244 709	1	Switch on lever
208	210 641	1	Washer 4,2/10/1
209	210 362	1	Hex nut M 3
210	234 548	1	Roller
211	210 143	3	Lock washer 1,5
212	218 591	1	Tension spring
213	201 184	1	Adjusting washer
214	242 298	1	Washer
215	244 331	1	Skating lever
216	210 146	1	Lock washer 3,2
217	237 543	1	Rubber bush
218	237 541	1	Grip rod complete
219	240 063	1	Lifting piece
220	210-353	1	Hex nut
221	240 066	1	Bearing plate
222	210 469	1	Machine screw
223	234 674	1	Brahing piece
224	210 587	1	Washer
225	234 588	1	Adjusting lever
226	230 087	1	Screw bolt
227	210 146	3	Lock washer 3,2
228	210 145	4	Lock washer 2,3
229	210 586	1	Washer
230	232 545	1	Leaf spring
231	234 593	1	Reversing angle
232	203 477	1	Washer
233	210 353	1	Hex nut
234	232 599	1	Latch
235	210 146	3	Lock washer
236	239 915	1	Square plate
237	210 472	1	Machine screw
238	210 586	1	Washer
239	245 247	1	Screw bolt
240	239 810	1	Locking spring
241	229 362	1	Guide bearing
242	210 145	4	Lock washer 2,3
249	209 436	3	Tab receptable
250	209 424	1	5-pole plug
251	207 303	1	Phono pick up cable complete
252	207 301	1	Phono pick up cable (cynch)
253	209 425	1	Cynch plug white
254	209 426	1	Cynch plug black
255	214 602	2	AMP-receptable
256	232 996	1	Mains lead Europe
257	232 995	1	Mains lead USA
258	231 079	1	Cable clamp
	261 952	1	CK 28 walnut console
	261 953	1	CK 28 agale black console
	261 954	1	CK 28 agale brown console
	227 986	1	CH 6 cover
	261 600	1	Operating instructions
	262 016	1	Operating instructions UAP
	260 491	1	Shipping carton CS

Subject to change!

Lubrication

All bearing and friction points of the unit are adequately lubricated at the works. Replenishment of oil and grease is only necessary after approximately 2 years of normal use of the record player as the most important bearing points (motor bearings) have sintered metal bushes.

Bearing points and friction faces should be lubricated sparingly rather than generously.

It is important that no oil grease should come in contact with the friction faces of the flat belt, drive pulley and flywheel rotor, otherwise slip will occur.

When using different lubricants, chemical decomposition can often take place. To prevent lubrication failure we recommend using the original lubricants stated below.

Fig. 22

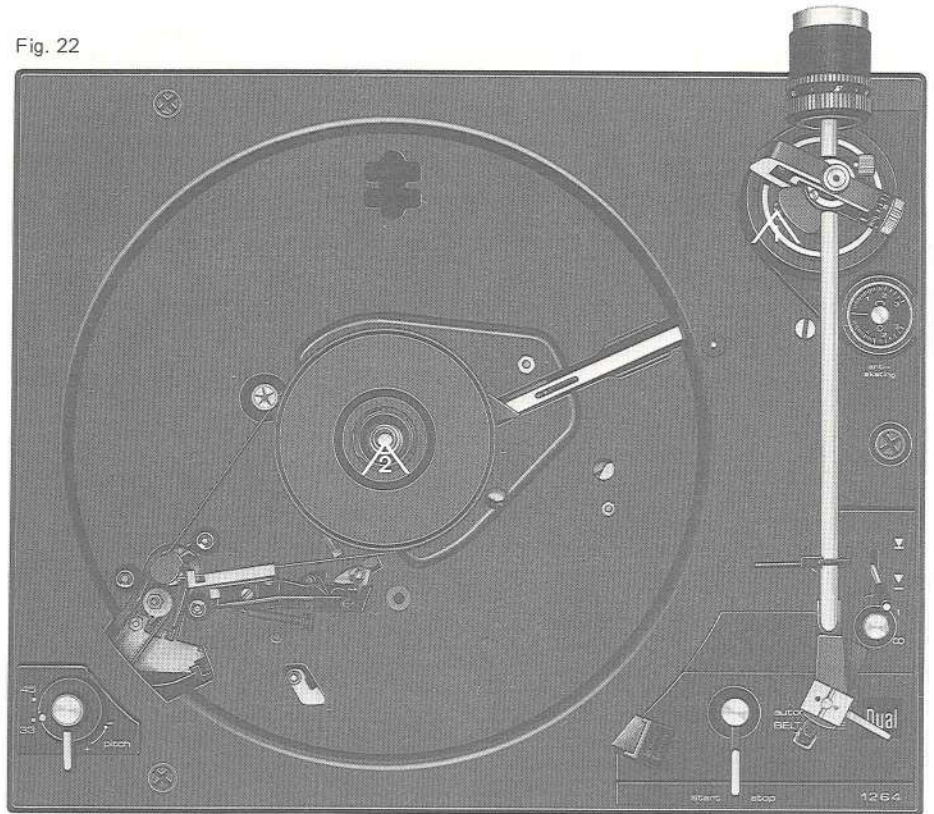

Fig. 23

1

Wacker Siliconeoil
AK 300 000

2

Renotac adhesive oil
No. 343

3

BP Super Viscostatic
10 W/40

4

Shell Alvania No. 2

5

Isoflex PDP 40

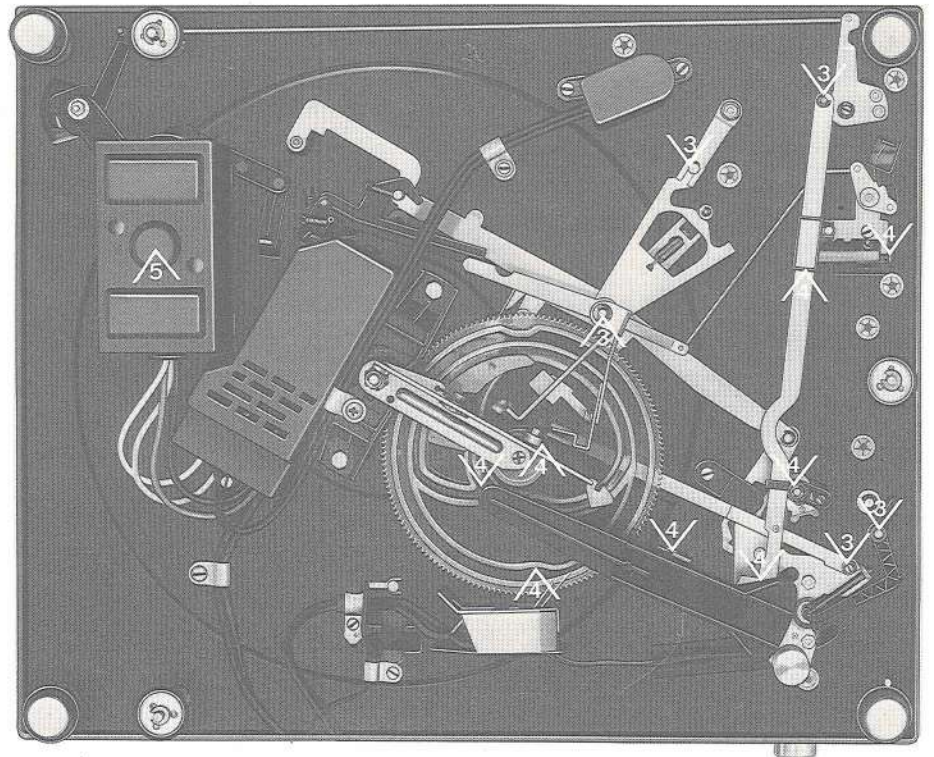

Dual Gebrüder Steidinger · 7742 St. Georgen/Schwarzwald