

Dual

Edition Oct. 1977

1237



Service Manual

Dual Gebrüder Steidinger 7742 St.Georgen/Schwarzwald

Fig. 1 Pick-up Connection Diagram

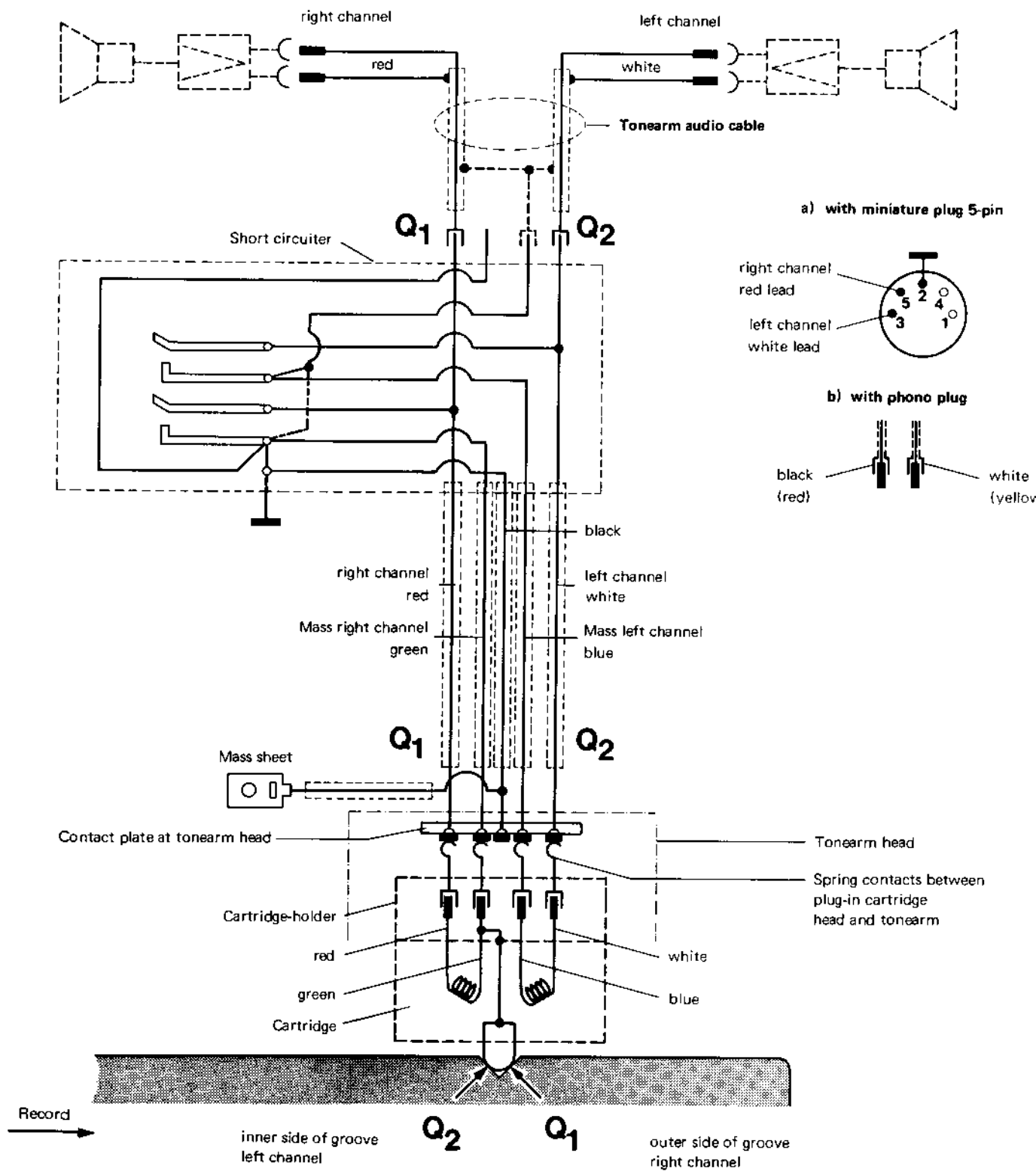

Contents

Page	
2	Pick-up Connection Diagram
3	Technical Data
4	Motor and Drive
4	Speed changeover
4	Platter / Sandwich platter
4	Flat Belt
4	Changing of Drive Pulley
5	Pitch Control
5	Tonearm and Tonearm Bearing
6	Removal of Tonearm from Bearing Frame
6	Removal of Tonearm assembly with Tonearm Bearing
6	Replacement of Spring Housing
6	Adjustment of Tonearm Bearing
6	Tonearm Control
6	Antiskating Device
7	Cue Control
7	Replacement of Cue Control assembly
7	Starting
8	Muting switch
8	Manual Start
8	Stopping
8	Record Drop
8	Shut-off and Change Cycle
8	Shut-off Mechanism
9	Adjustment points: Tonearm set-down point
9	Switch off position
9	Release rocker
9	Tonearm vertical lift
9	Tonearm does not set down or lowers onto record too quickly
9	Platter does not turn when unit is connected and start switch operated
10	Correct nominal speed obtained only at extreme setting of pitch control
10	Platter does not come up to speed
10	Stylus slips out of record groove
10	Motor will not shut-off
10 – 13	Replacement parts with exploded view
14	Lubricating Instructions

Technical data

Current Type	AC 50 or 60 cycles, with appropriate motor pulleys
Line Voltage	110 – 125 V and 220 – 240 V, selector
Drive	Dual Eight Pole Synchronous Motor via Flat Belt to Flywheel Rotor
Power consumption	approx. 10 watts
Current requirements	at 220 V, 50 Hz: approx. 75 mA at 117 V, 60 Hz: approx. 140 mA
Platter	non magnetic 1 kg, 270 mm ϕ
Platter speeds	33 1/3 and 45 rpm, automatic tonearm setdown coupled to speed selector
Pitch control	Adjustment of approx. 1 semi-tone (6 %) at both platter speeds.
Wow and flutter	$< \pm 0,1$ % rated in accordance with DIN 45 507
Signal-to-noise-ratio	Rumble unweighted signal-to-noise-ratio > 40 dB
(according to DIN 45 500)	Rumble signal-to-noise-ratio > 60 dB
Tonearm	Torsion-resistant aluminium tonearm in four point gimbal suspension.
Tonearm bearing friction	vertical $< 0,08$ mN (0.008 g) horizontal $< 0,16$ mN (0.016 g)
Tracking force	0 - 50 mN (0 - 5 p) continuously variable reliable as from 5 mN (0.5 g) tracking force
Pick-up head	Detachable, suitable for all pick-up cartridges with Dual catch mounting and 1/2" mounting and a deadweight of 4.5 - 10 g (including hardware)
Weight	approx. 3.8 kg

For dimensions and cutout refer to Installation Instructions.

Fig. 2 Motor and drive

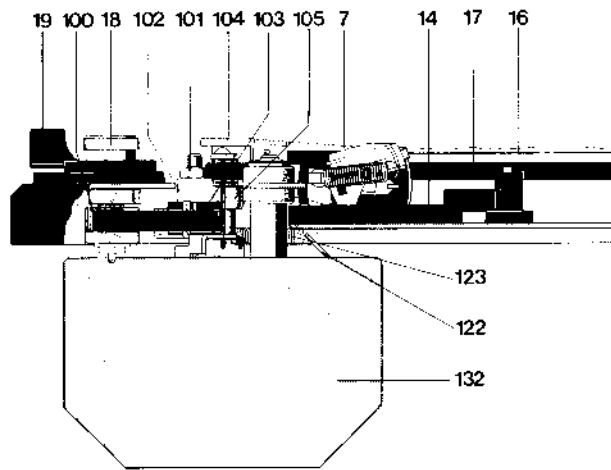

Fig. 3

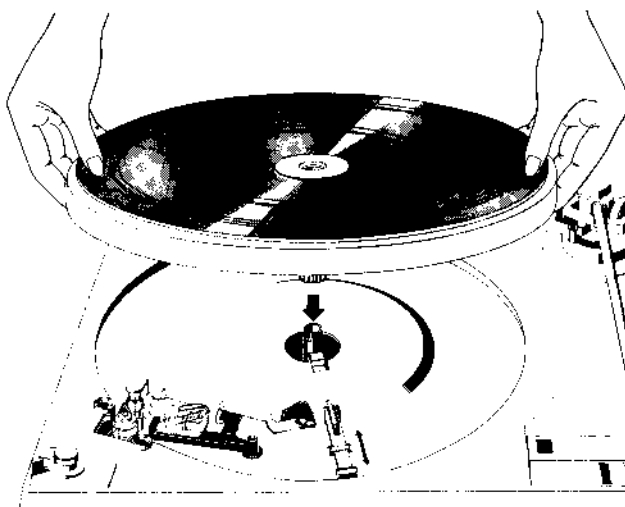
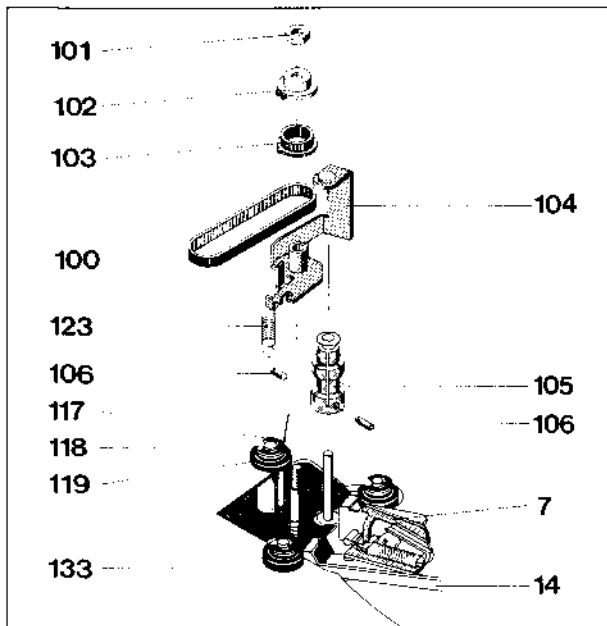

Fig. 4



Note: The numbers listed above refer to the below spare parts lists and exploded views.

Motor and Drive

Power for the turntable platter and the changing mechanism is supplied by a split eight pole synchronous motor suspended by radially located elastic mounts and having a very small stray magnetic field as well as little vibration.

The speed of the motor is independent of line voltage, temperature or load variations. Speed is dependent on and proportional to power line frequency. The motor is adapted to 50 or 60 cycle (Hz) power line frequencies by the correct choice of the motor pulley.

Pulley for 50 Hz Art.-No. 234 453

Pulley for 60 Hz Art.-No. 243 454

The drive is transmitted to the platter by means of the flat belt (17).

Speed Changeover

Platter speeds of $33 \frac{1}{3}$ and 45 rpm are adjusted by linking the flat belt (17) to the corresponding step of the drive pulley (105) (Fig. 5).

The speed switch lever is brought into the required position (33 or 45 rpm) by means of the speed selection lever (19), the switch lever (108) and the spring lever of the switch levers. If the machine is switched off, then the switch lever is interlocked by the stop lever (14). The speed is only preselected in this way. The stop lever (14) is only released when the platter (16) turns. This then moves the flat belt (17) onto the required step of the drive pulley (105).

Platter

The platter (16) is held in position by the platter locking lever (155). When removing the platter, lift the platter covering over one of the cutouts and rotate the platter until the cutout is above the drive pulley. Detach the flat belt (17) from the drive pulley (105) and lay it on the running surface of the platter. Rotate the platter until the cutout is above the platter locking lever (155). Push this outward and lift the platter out.

Sandwich platter

The sandwich platter (16) is secured by means of a spring clip on the bearing tube of the bearing housing (164). This clip should be taken away when removing the platter.

Flat Belt

The exchanging of the flat belt is described above with the platter to be removed. Fit the new belt to the running surface of the platter (16).

Warning: The ground (matt) side of the belt must be in contact with the running surface of the platter. Reinstall the platter and lay the flat belt back over the drive pulley (105).

Changing the drive pulley

1. Remove the flat belt (17) from the drive pulley (105) and take off the platter (16). Remove the toothed belt (100).
2. Detach tension spring (123) from screening sheet (122).
3. Remove the hexagonal screw (101), remove the adjustment cam (102), the belt pulley (112) as well as the counter bearing (104).

4. Loosen set screws (106) and remove motor pulley (105). Place complete replacement motor pulley on motor axle. Remove conical sleeve. Be careful with the interior distance bushing. Adjust motor pulley vertically (see Fig. 5) and tighten set screws (106) uniformly. Place conical sleeve into the motor pulley (105).
5. Outer counter bearing (104), belt pulley 2 (112) and adjustment cam (102) should now be fitted and the hexagonal head mounting screws tightened (101). Replace the tension spring and toothed belt (100). Install the platter (16). Fit the flat drive belt (17) onto the drive pulley (105).
6. Setting up the rotational speed: set the regulator knob (18) to its central position. By loosening or tightening the hexagonal nut (101) adjust the rotational speed.

Fig. 6 Diagram for Motor Connection

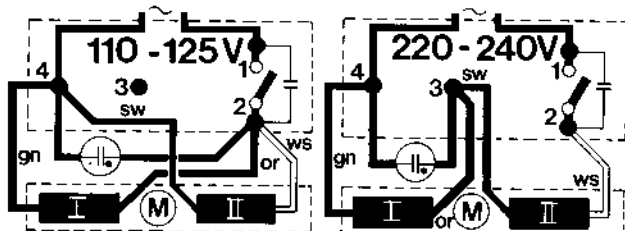

Fig. 5

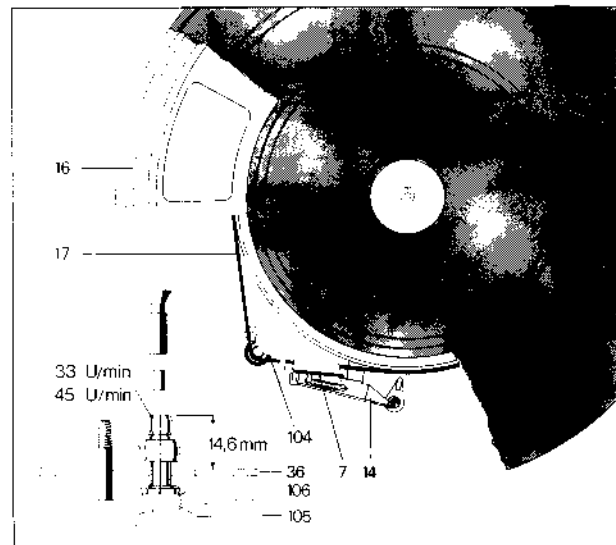

Fig. 7 Pitch control

Pitch Control

The unit has a separately adjustable pitch control the two standard speeds 33 1/3 rpm and 45 rpm can be varied by approximately 6% (1 semitone).

By turning the fine speed adjustment knob (18) the belt pulley 2 (112) is moved. This rotation is transferred by means of the toothed belt (100) to the drive pulley 1 (103). (Fig. 7) thus moving the counter bearing (104) upwards or downwards. The taper bush of the drive pulley is designed to vary the diameter of the drive pulley thus varying the nominal speed within the tolerance of $\pm 3\%$.

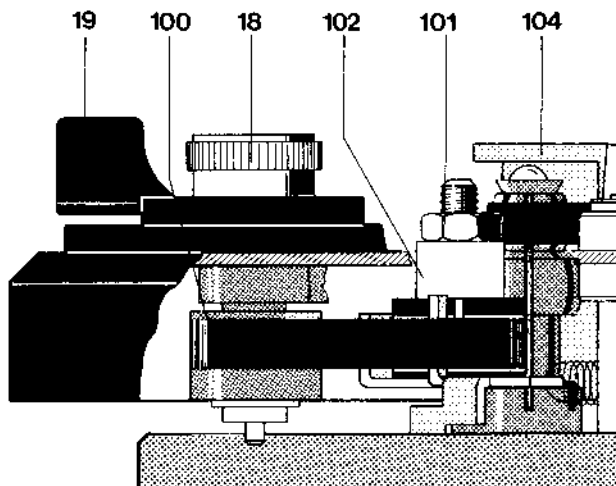

Fig. 8 Tonearm bearing

Tonearm and Tonearm Bearing

The Dual 1237 has a feather-light, extremely torsion-resistant all-metal tonearm which is suspended in a gimbal. Suspension is by means of 4 hardened and precision polished steel points which rest in precision ball bearings. Tonearm bearing friction is thus reduced to a minimum.

Bearing friction vertical $< 0,08 \text{ mN}$ (0,008 p)
 Bearing friction horizontal $< 0,16 \text{ mN}$ (0,016 p)

As a result, it ensures most favourable pick-up conditions. Before adjusting the pick-up force to suit the built-in pick-up cartridge the tonearm is balanced with the scale set to zero. Coarse adjustment is carried out by moving the weight with the pin (60), the subsequent fine adjustment by turning the weight. The balance weight is designed such that pick-up cartridges having a deadweight (incl. hardware) of 4.5 - 10 g can be balanced. The tracking force is adjusted by turning the graduated spring housing (71) incorporating a coil spring. The scale has markings for a range of adjustment from 0 to 50 mN (0 to 5 p) which permit accurate adjustment of the tracking force.

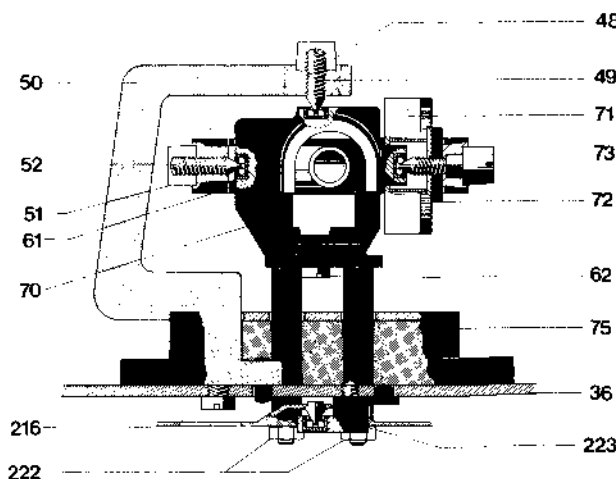
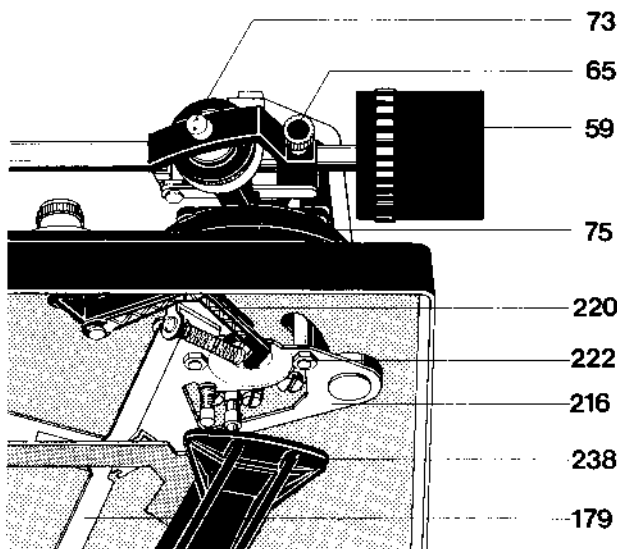

Fig. 9 Tonearm bearing



Removing the tonearm from the bearing frame

1. Clamp unit in the repair stand. Remove the counter-weight (59), remove clamp screw (65). Set spring housing scale (71) to zero.
2. Turn the unit over and remove the shield (194). Unsolder the tonearm connections on the muting switch (191).
3. Turn the unit back to normal position. Remove the two fixing screws (67) (SW 4.5) and the cable holder (66). Remove the tonearm (58).

Reverse this procedure when reassembling

Removal of the complete tonearm and bearing assembly
We recommend the following procedure.

1. Clamp unit in the repair stand. Secure the tonearm (58) and remove the counterweight (59). Set spring housing scale (71) to zero.
2. Turn the unit over and remove the shield (194). Unsolder the tonearm connections on the muting switch (191).
3. Remove lock washers (197 and 236) and the axle (198). Remove the main lever (238).
4. Remove the hexagonal nut (222). Hold the tonearm securely and remove the machine screw (53). Lift out the complete tonearm and bearing assembly.

Fig. 10 Tonearm control

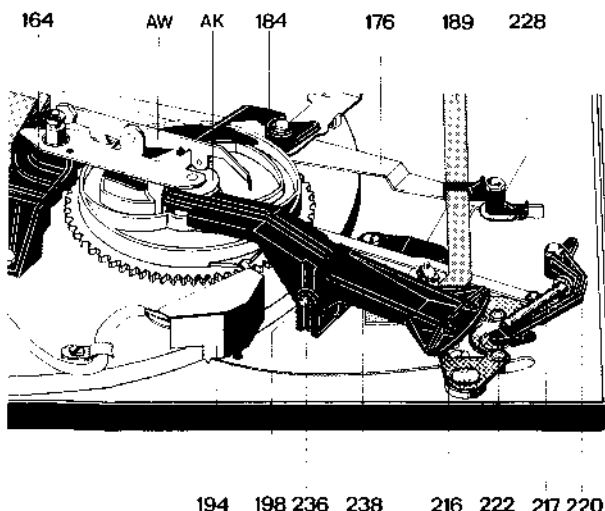

When reassembling the tonearm proceed in the reverse order, taking care that the threaded pin (49) is correctly seated in the bearing when fastening the frame (50) (see Fig. 8).

Replacing spring housing

Remove tonearm (58) from bearing frame (64) as described above. Loosen lock nut (51) and threaded pin (52). Unscrew bearing screw (73). Lift bearing frame (64). Remove spring housing (71) and washer (72). When installing note that the helical spring catches the bearing frame. Slide in washer (72) and tighten bearing screw (73). Reinstall tonearm (58). Set bearing play as described below using threaded pin (52) and lock nut (51).

Adjusting the tonearm bearing

First balance tonearm exactly. Both bearings must have slight, just perceptible play.

The horizontal tonearm bearing is correctly adjusted when at anti-skating settings "0.5" and being touched it slides in without resistance. The vertical tonearm bearing is correctly adjusted when it swings in after being touched. The play of the horizontal tonearm bearing should be adjusted with threaded pin (52).

Tonearm Control

Automatic movement of the tonearm is initiated by the control cams on the inside of the cam wheel (157) on rotating through 360°.

The control elements for raising and lowering are the main lever (238) and lift pin (215), for horizontal movement the main lever (238) with segment (216).

The automatic tonearm set down is designed for 30 cm and 17 cm records and is coupled to the platter speed changeover. The set-down points of the tonearm are determined by the spring pin of segment (216) contacting the setting rail (189). Limitation of the horizontal movement of the tonearm is produced by the pin of segment contacting the stop attached to the setting rail (189). Only during set-down does main lever (238) lift the slide bar (189) and the stop attached to it which, as a result, moves into the swivel range of the stop pin fitted on the segment. After completion of set down (lowering of the tonearm onto the record) the setting rail (189) is released again and returns to neutral position. As a result the stop moves out of the swivel range of the stop pin so that unimpeded horizontal movement of the tonearm is possible for playing.

Antiskating Device

The adjustment of the antiskating force is made by turning the indicator disc located on the supporting back (75). The skating lever (226) is displaced from the tonearm fulcrum by an amount depending on the setting of this control. The antiskating force is transmitted to the tonearm (58) via the tension spring (217) and segment (216).

Optimum adjustment is carried out at the works for styli with a tip radius of 15 µm (spherical), 5/6 and 18/22 µm (elliptical), and CD 4-cartridges.

Any alteration can only be carried out with the aid of a Dual-Skate-0-Meter and a test record and should only be done by an authorized service station.

Fig. 11

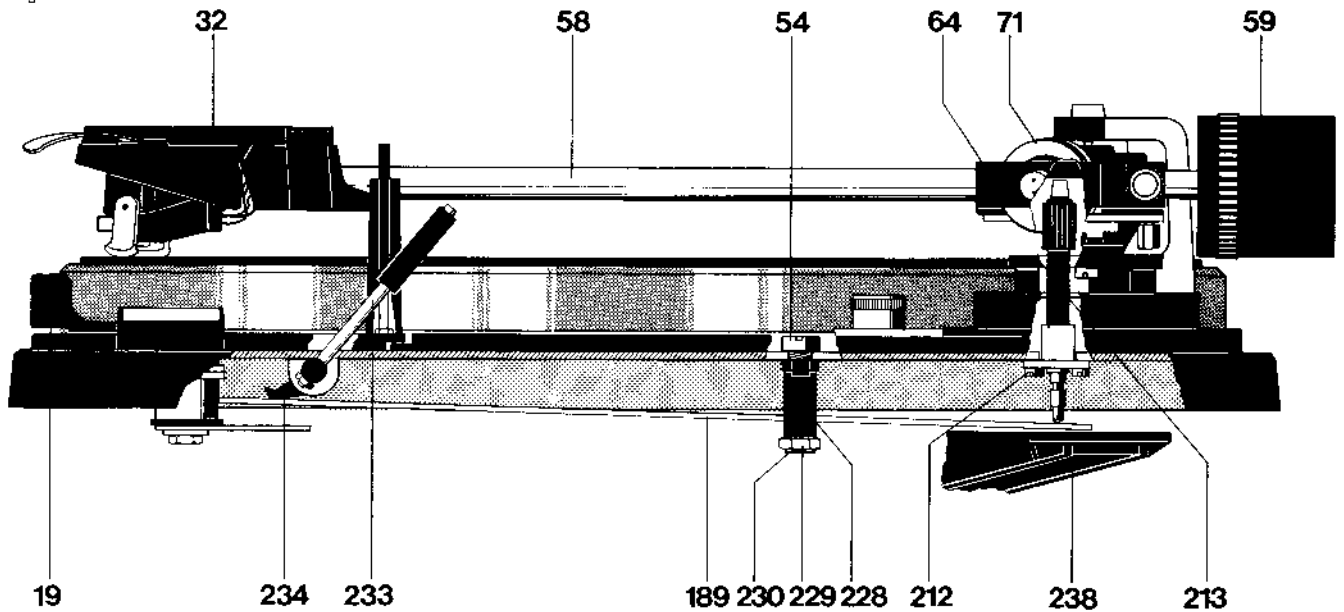

Tonearm lift

Raising the lever (233) to position "▼" or "▲" moves the lift cam (234) and the setting rail (189) so that the tonearm is raised from the record (or lowered onto it). If the unit is started with the arm lever in the "▼" position, then the tonearm is guided over the record by the set-down mechanism. Only when the lever (233) is brought to the position "▲" will the tonearm be lowered onto the record. The vertical lift height can be adjusted by means of the locating screw (54) and should be 3 – 5 mm.

Exchanging the lift plate

When changing the lift plate (213), we recommend the following procedure:

1. Clamp the unit in a repair stand and lock the tonearm in rest position. Turn the unit over.
2. Remove lock washers (197 and 236) and the axle (198). Remove the main lever (238).
3. Remove lock washer (230). Turn the locating screw (54) until the hexagonal unit (229) can be removed. Lift the setting rail (189) and the guide bearing (228) and pivot toward the cam wheel (157).
4. Remove the two machine screws (212) and take out the lift plate (213).

Reverse this procedure when reassembling.

Start

Switching the start/stop lever (78) into the "start" position initiates the following sequence:

- a) The start lever (186) rotates the switch lever (181) which is pivoted about the notched stud. At the same time, the switch arm (176) is moved and the motor (132), via the mains switch (138), and the platter starts turning.
- b) Operating the start/stop lever (78) also releases the start slide (35) which is drawn toward the cam by means of the tension spring (34). This causes the shut-off lever to engage with the drive pinion and the cam turns.
- c) This switch lever (181) is coupled to the switch angle (184) and this is brought into the range of the shift lever so that the next rotation of the cam forces this into its starting position.

Fig. 12

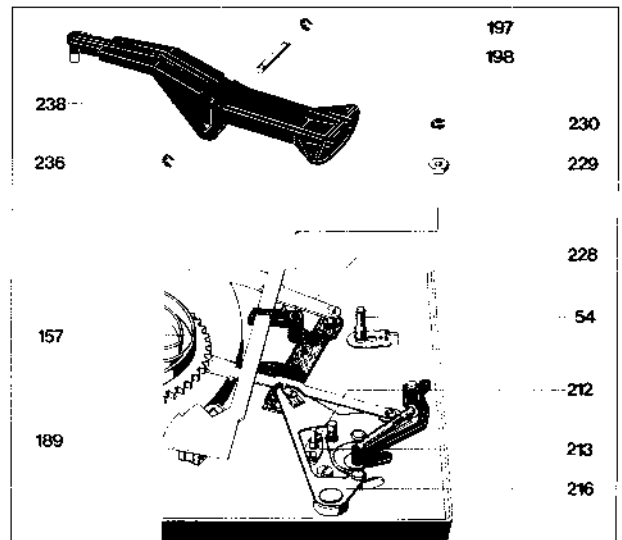

Fig. 13

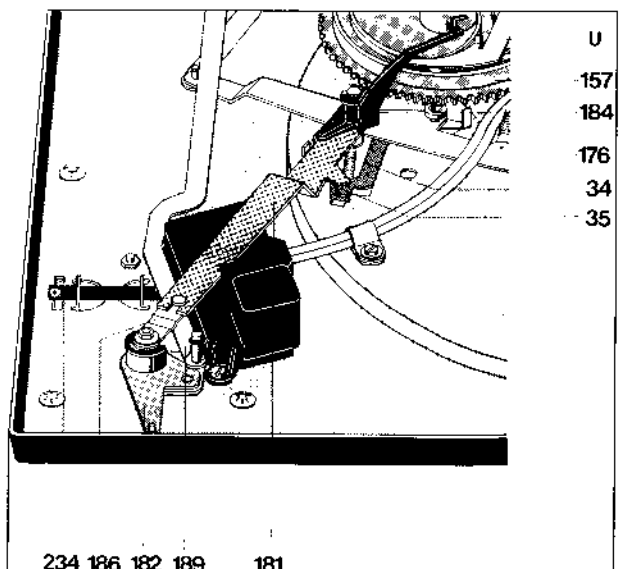
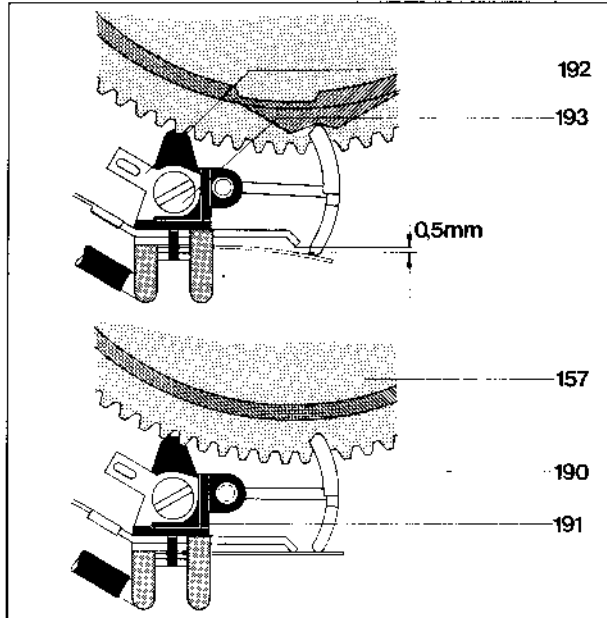

Fig. 14 Short circuit



Short Circuiter

To prevent disturbing noises during automatic operation of the tonearm the unit is fitted with a short circuiter. Control of the switch springs for both channels is effected by the camwheel. With the unit in neutral state the short circuit of the pick-up leads is eliminated.

Adjustment

In zero position of the cam there should be a clearance of approximately 0.5 mm between the contacts of the short circuiter. This clearance should be adjusted by bending the short circuit contact. The contacts should be sprayed with a suitable cleaning agent.

Fig. 15

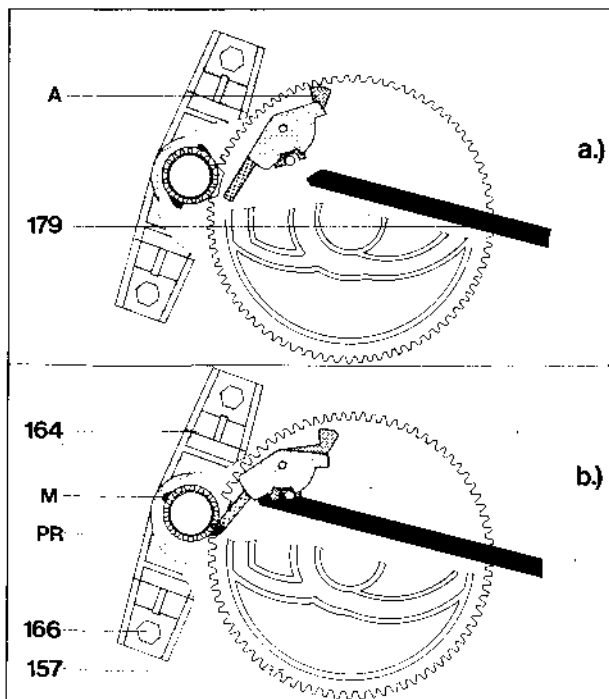

Manual start

The latch (171) which is connected to the switch arm (176) engages in the four-sided plate when the tonearm is moved manually. The switch arm (176) connects the mains supply to the motor (132) via the power switch (138) and the platter rotates. When the run-out of the record is reached, the tonearm is lifted and the motor is switched off automatically. If the tonearm is lifted off the record before the run-out, and returned by hand to the pillar, then the bolt on the segment (216) engages the latch (171) so that the switch arm is returned to its starting position. This switches off the mains supply.

Stopping

When control lever is set to "stop" position the start lever (35) which is pulled towards the cam by means of tension, is feed. As a result, the shut-off lever is moved into the range of dogs cam. The cam follower lever remains in its stop position.

Record drop

Insert the appropriate spindle — AW 3 for standard records (7 mm or 1/4" center hole) or AS 12 for 45 rpm records (38 mm or 1 1/2" center hole).

The record drop is initiated by the cam wheel (157) whose drop cam surface (AK) controls the release rocker (AW) and the changer actuator rod.

Shut-off and change cycle

The dog (M) on the turntable platter gear (PR) and the shut-off lever (A) actuate both the change cycle at the end of the record as well as the shut-off after the last record in a stack is played.

At the end of a record, the tonearm moves towards the center at an accelerated rate due to the increased pitch of the grooves. This motion carries the shut-off lever (A) towards the dog by means of the stop lever (179). The eccentric dog pushes the shut-off lever (A) back at each revolution as long as the tonearm advance is only one normal record groove (Fig. 15).

The run-out groove with its steeper pitch moves the shut-off lever against the dog with greater force, engaging the shut-off lever (A) and causing the main cam wheel (157) to be driven out of its neutral position by the turntable platter gear (Fig. 15 b).

Shut-off mechanism

Shut-off and change functions are determined by the position of the cam follower lever (U). After every start or record drop, the cam follower lever is brought to its stop position by the main lever (238) (longer end towards the center of the main cam). As the record is dropped the cam follower lever (U) is turned to its start position by the cam rocker, so that the tonearm can swing in toward the record and be lowered on to it. If there are no more records on the spindle, and the cam rocker cannot turn the cam follower lever, the lever remains in its stop position and allows the tonearm to swing to its rest position.

When the main cam wheel (157) returns to its neutral position, the switch arm (176) drops into a cut-out in the main cam, opening the power switch (138) and disengaging the drive idler.

Adjustment

Tonearm set-down point

After removing the stop plate (79) (by pressing it forward and lifting the rear edge first) the adjustment screw (A) is accessible. The needle set-down point can be varied toward the centre or the outside by turning the adjustment screw to the right or left respectively.

The switch off position

With the tonearm on the pillar, the eccentric (B) can be adjusted to alter the switch off position. The eccentric is accessible through the supporting back (75).

If the unit switches off too early or not at all, then the eccentric (B) should be turned to the right or left respectively (see Fig.17).

Release rocker

The eccentric screw (c) is used to alter the travel of the changing bolt (167). The setting is correct when at the rest position of the cam wheel (157), and with interlocked changer spindle, the changing bolt (167) has a travel of 0.2 mm.

Tonearm vertical lift

The adjustable sleeve (210) is used to adjust the tonearm vertical lift (for automatic operation). Pull out the mains plug, unlock the tonearm, turn the cam wheel (157) until the tonearm reaches its highest point of travel. The tonearm should now be approximately 4 mm above the pillar stop (see Fig. 19). Adjust by means of sleeve (210).

Fig. 18

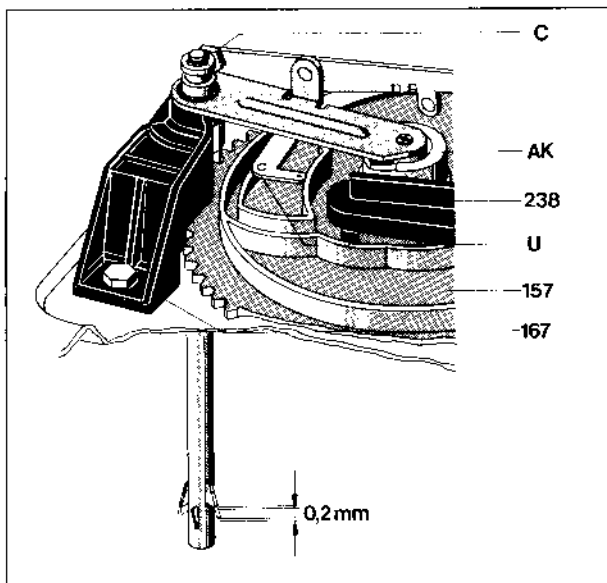

Defect

Tonearm does not set down or sets down too fast

Cause

Damping is too great or too small due to dirt in the silicone oil of the lift tube

Defect

Platter does not turn after machine is connected and "start" switch is pressed.

Cause

- Power supply is interrupted.
- Drive pulley is loose.

Fig. 16

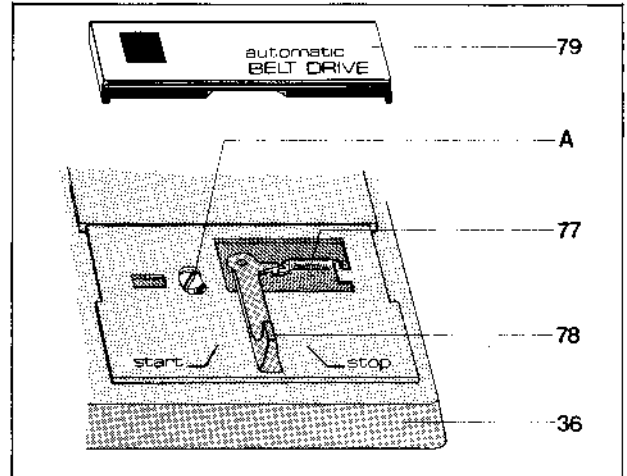

Fig. 17

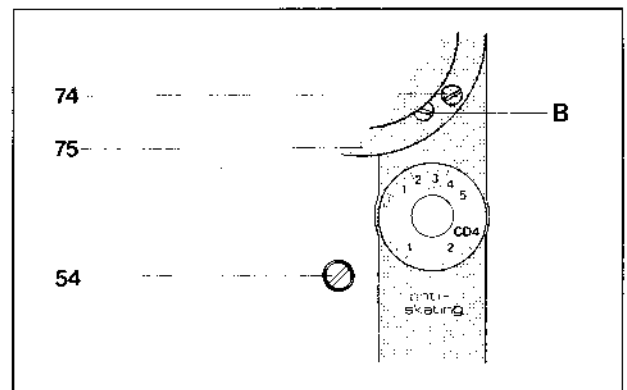
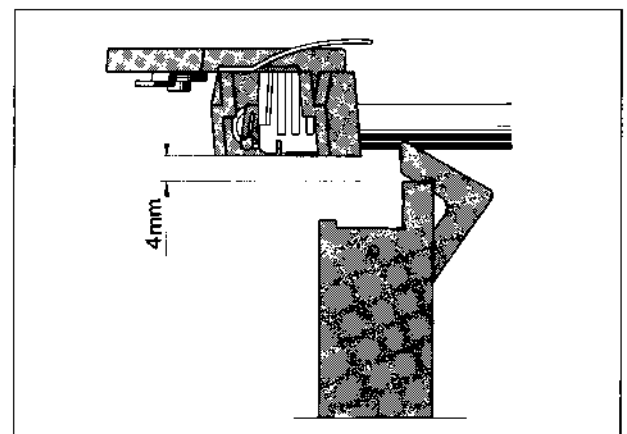

Fig. 19



Repair

Remove the lift plate assembly (213) as described on page 7. Remove the guide (208) on the lift rod, remove the lock washers (209 and 211) together with the adjustment sleeve (210). Take out the lift pin (215) and compression spring (214), clean rod and tube and then coat both rod and tube with "Wacker Silicone oil AK 300 000". Reassemble and wipe away any extraneous oil.

Repair

- Check connections on switching board and mains plug
- Tighten screws of drive pulley.

Defect	Cause	Repair
Rotational speed lies at limit of adjustment range.	Bad adjustment of bearing.	Set control knob (18) to its central position, loosen or tighten the hexagonal nut (101) to set up the correct rotational speed.
Platter does not come up to speed.	a) Drive pulley incorrect for mains frequency. b) Slip between flat belt and drive pulley or flat belt and platter.	a) Change pulley to correct size for mains frequency. b) Clean the contact surfaces of the flat belt, drive pulley and platter. If necessary renew the flat belt.
Needle slides out of record groove.	a) Bearing friction in tonearm too high. b) Steel ball (180) for shut off rail missing.	a) Readjust tonearm bearing. b) Replace steel ball (180).
Motor does not switch off when tonearm is on the billar	Interference suppression capacitor (in mains switch) has short circuit.	Replace interference suppression capacitor in mains switch.

Replacement parts

Pos.	Part.-No.	Qty.	Description	Pos.	Part. No.	Qty.	Description
1	215 470	1	Automatic spindle AS 12	39	239 414	2	Shipping screw compl.
2	213 895	1	Automatic spindle AW 3	40	237 668	2	Special screw
3	220 213	1	Centering piece	41	210 146	5	Lock washer 3.2
4	201 101	1	Centering pin	42	201 632	2	Rubber washer
5	238 434	1	Washer	43	237 117	2	Washer
	243 043	1	Washer	44	237 118	2	Lock washer
6	242 598	1	Turntable mat compl.	45	241 556	1	Pointer compl.
	243 518	1	Turntable mat (model sandwich)	46	211 673	1	Washer 1.7/3.5/0.3
	242 939	1	Turntable compl. (model G)	47	237 672	1	Nail
	243 517	1	Turntable (model W)	48	234 635	2	Lock nut
7	241 549	1	Support compl.		243 041	2	Stop nut (model W)
8	210 472	1	Machine screw AM 3 x 4	49	230 063	1	Threaded pin
9	210 586	1	Washer 3.2/7/0.5	50	242 602	1	Frame compl.
10	238 819	1	Tension spring		243 508	1	Frame compl. (model W)
11	240 000	1	Tension spring	51	234 635	2	Lock nut
12	239 950	1	Switch-off lever		243 041	2	Lock nut (model W)
13	210 145	6	Lock washer 2.3	52	234 634	1	Threaded pin
14	241 551	1	Stop lever compl.	53	210 516	1	Machine screw AM 4 x 8
15	210 194	1	Grip Ring 2 x 0.6	54	239 809	1	Locating screw
16	242 599	1	Platter with mat compl.		243 030	1	Locating screw (model W)
	242 938	1	Platter with mat (model G)	55	210 147	1	Lock washer
	242 940	1	Platter with mat (model sandwich)	56	232 978	1	Support compl.
	243 506	1	Platter with mat (model W)	57	210 362	1	Hex nut
	200 543	1	Ring (for sandwich platter)	58	241 560	1	Tonearm compl.
17	234 435	1	Flat belt		243 509	1	Tonearm compl. (model W)
18	238 958	1	Adjustment knob	59	242 604	1	Weight compl.
	243 033	1	Adjustment knob (model W)		243 511	1	Weight compl. (model W)
19	239 957	1	Speed selector lever	60	239 277	1	Pin
20	242 600	1	Speed selector cover		243 044	1	Pin (model W)
21	200 444	3	Spring washer	61	233 744	1	Bracket
22	232 975	1	Spring suspension compl. (motor side front)	62	239 777	1	Machine screw AM 3 x 7
	232 972	1	Spring suspension compl. (motor side back)	64	242 605	1	Bearing frame compl.
	234 815	1	Spring suspension compl. (tonearm side)		243 512	1	Bearing frame (model W)
23	230 529	3	Threaded part	65	241 447	1	Clamp screw
24	230 523	1	Compression spring (motor side front)		243 040	1	Clamp screw (model W)
	230 521	1	Compression spring (motor side back)	66	241 893	1	Cable holder
	234 109	1	Compression spring (tonearm side)	67	227 467	2	Hexagon sheet metal screw 2.9 x 6.5
25	200 723	3	Rubber damping	70	242 606	1	Bearing compl.
26	200 722	3	Steel cup		243 513	1	Bearing compl. model (W)
27	241 554	1	Contact plate compl.	71	241 565	1	Spring housing compl.
28	234 611	1	Handler		243 514	1	Spring housing compl. (model W)
29	210 182	1	Lock washer 4.2/8	72	237 563	1	Washer
30	210 630	1	Washer 4.2/8/0.5	73	237 564	1	Bearing screw
31	210 197	1	Ring 4 x 0.8		243 051	1	Bearing screw (model W)
32	241 555	1	Tonearm head compl.	74	239 193	3	Fillister sunk screw M 3 x 6
33	236 242	1	Cartridge mount TK 24	75	242 607	1	Supporting back compl.
34	231 017	1	Tension spring		243 515	1	Supporting back compl. (model W)
35	239 926	1	Start slide	76	200 444	1	Spring washer
36	242 601	1	Mounting	77	226 357	1	Tension spring
	243 507	1	Plate	78	239 938	1	Switch lever compl.

Replacement parts

Pos.	Part. No.	Qty.	Description	Pos.	Part. No.	Qty.	Description
79	242 608	1	Stop plate compl.	168	240 426	1	Changing bolt compl. (model sandwich)
	242 936	1	Stop plate compl. (model G)	169	213 920	1	Compression spring
	243 516	1	Stop plate compl. (model W)	170	213 921	1	Sleeve
80	242 609	1	Supporting front compl.	171	210 145	6	Lock washer
81	200 444	2	Spring washer	172	239 913	1	Latch cpl.
100	238 832	1	Toothed belt	173	239 915	1	Square plate
101	222 200	1	Hex nut	174	210 472	1	Machine screw
			M 3.5				AM 3 x 6
102	241 641	1	Adjustment cam	175	210 366	1	Hex nut
							M 4
103	241 642	1	Toothed belt pulley 1	176	239 927	1	Switch arm
104	241 644	1	Counter Bearing	177	239 931	1	Roll
105	234 453	1	Drive pulley compl.	178	210 147	2	Lock washer
			50 Hz				4
	234 454	1	Drive pulley compl.	179	239 916	1	Stop lever
			60 Hz	180	209 358	1	Ball
106	233 137	2	(Set screw)	181	239 932	1	Switch lever
			2.5 x 3	182	239 919	1	Adjustment lever
107	238 828	1	V-spring	183	232 621	1	Lock washer
108	238 827	1	Switch lever	184	239 933	1	Switch angle
109	238 826	1	Change over part	185	210 147	2	Lock washer
110	210 144	1	Lock washer				4.2/10/1.5
			1.9	186	239 941	1	Start lever
111	210 149	1	Lock washer				M 3
			6	187	210 642	1	Washer
112	240 027	1	Toothed belt pulley 2	188	210 361	1	Hex nut
113	240 035	1	Washer				M 3
114	210 607	1	Washer	189	239 936	1	Setting rail
			3.2/10/0.5	190	239 807	1	Contact arm
115	210 362	1	Hex nut	191	242 612	1	Muting switch compl.
			M 3	192	239 806	1	Ground shut
116	232 615	1	Compression spring	193	210 486	1	Machine screw
							AM 3 x 8
117	210 146	5	Lock washer	194	239 808	1	Shield
			3.2	195	234 106	1	Cone spring
118	241 084	3	Washer	196	210 145	6	Lock washer
			4.2/8/1	197	210 145	6	Lock washer
119	242 285	2	Sleeve	198	200 528	1	Axle
120	210 480	1	Machine screw	199	239 947	1	Bearing support
			AM 3 x 6	208	216 844	1	Guide
121	210 609	1	Washer	209	210 143	2	Lock washer
			3.2/10/1				1.5
122	239 232	1	Screening sheet compl. (SM 860-2)	210	218 318	1	Sleeve
	242 419	1	Screening sheet compl. (SM 860-4)	211	210 143	2	Lock washer
							1.5
123	233 777	1	Tension spring	212	210 472	2	Machine screw
124	241 570	1	Top bearing bracket				AM 3 x 4
125	209 939	1	Sleeve	213	242 613	1	Lift plate compl.
126	242 587	1	Stator 110/220 V compl. (SM 860-4)	214	234 798	1	Compression spring
127	233 815	1	Machine screw	215	240 009	1	Lift pin
			AM 2.5 x 18	216	242 614	1	Segment compl.
128	241 571	1	Armature compl.	217	218 591	1	Tension spring
129	241 572	1	Bottom bearing bracket compl.	218	201 184	1	Adjustment washer
130	238 516	1	Screening sheet	219	242 298	1	Lock washer
131	210 525	2	Machine screw	220	239 917	1	Skating lever compl.
			AM 4 x 25	221	210 146	5	Lock washer
132	241 573	1	Motor SM 860-2 compl.	222	210 362	2	Hex nut
	242 585	1	Motor SM 860-4 compl.				M 3
	242 111	1	Sleeve	223	242 615	1	Counter bearing cpl.
133	231 079	1	Cable holder	224	203 475	1	Sink screw
136	236 335	1	Slide				M 3 x 8
137	242 581	1	Power switch compl.	225	210 145	6	Lock washer
138	242 582	1	Power switch compl. with spec. C.	227	239 935	1	Compression spring
	236 999	1	Power switch compl. (for single-pole plug)	228	239 934	1	Guide bearing
				229	210 366	1	Hex nut
139	200 444	1	Spring washer				M 4
140	233 012	1	Switch plate compl.	230	210 145	6	Lock washer
	236 606	1	Switch plate compl. with spec. C.				2.3
141	241 883	1	Capacitor 10 nF/250 V	231	239 810	1	Fuse spring
	230 355	1	Capacitor 68 nF/250 V/20 %	232	237 543	1	Sleeve
142	230 148	1	Switch angle	233	237 541	1	Lever compl.
143	239 732	1	Tension spring		243 028	1	Lever compl. (model W)
144	219 200	1	Snab spring	234	239 909	1	Lift cam
145	242 102	1	Cover	235	210 353	1	Hex nut
	233 421	1	Cover (for single-pole plug)				M 2
146	210 498	1	Machine screw	236	210 145	6	Lock washer
			M 3 x 28	237	210 147	6	Lock washer
147	239 925	1	Switch rod				4
148	242 601	1	Plouinting plate	238	242 616	1	Main lever
	243 507	1	Base plate (model W)	241	209 436	3	Pick flat plug shell
154	237 665	1	Tension spring	242	209 424	1	Five pole plug
155	239 788	1	Platter locking lever	243	207 303	1	Pick-up lead compl.
156	229 754	1	Ball bearing	244	207 301	1	Pick-up lead compl. with cynch plug
	242 657	1	Washer (model sandwich-platter)	245	209 425	1	Cynch plug white
157	242 610	1	Cam wheel cpl.	246	209 426	1	Cynch plug black
158	200 522	1	Snab spring	247	214 602	2	AMP connector
160	239 789	1	Slip washer	248	232 996	1	Power cable europe compl.
161	227 045	1	Tension spring	249	232 995	1	Power cable US compl.
162	229 698	1	Tension spring		214 120	1	Hardware for cartridge mounting cpl.
163	210 145	1	Lock washer		241 159	1	Operating instruction
			2.3		241 439	1	Operating instruction UAP
164	242 611	1	Bearing housing compl.		241 158	1	Mounting instruction
	242 941	1	Bearing housing compl. (model sandwich)		241 083	1	Shipping carton
165	200 650	1	Rubber sleeve		242 627	1	Shipping carton CS
166	213 155	2	Machine screw				
			M 4 x 6				
167	240 005	1	Changing bolt compl.				

Alterations reserved

Fig. 20 Exploded view 2

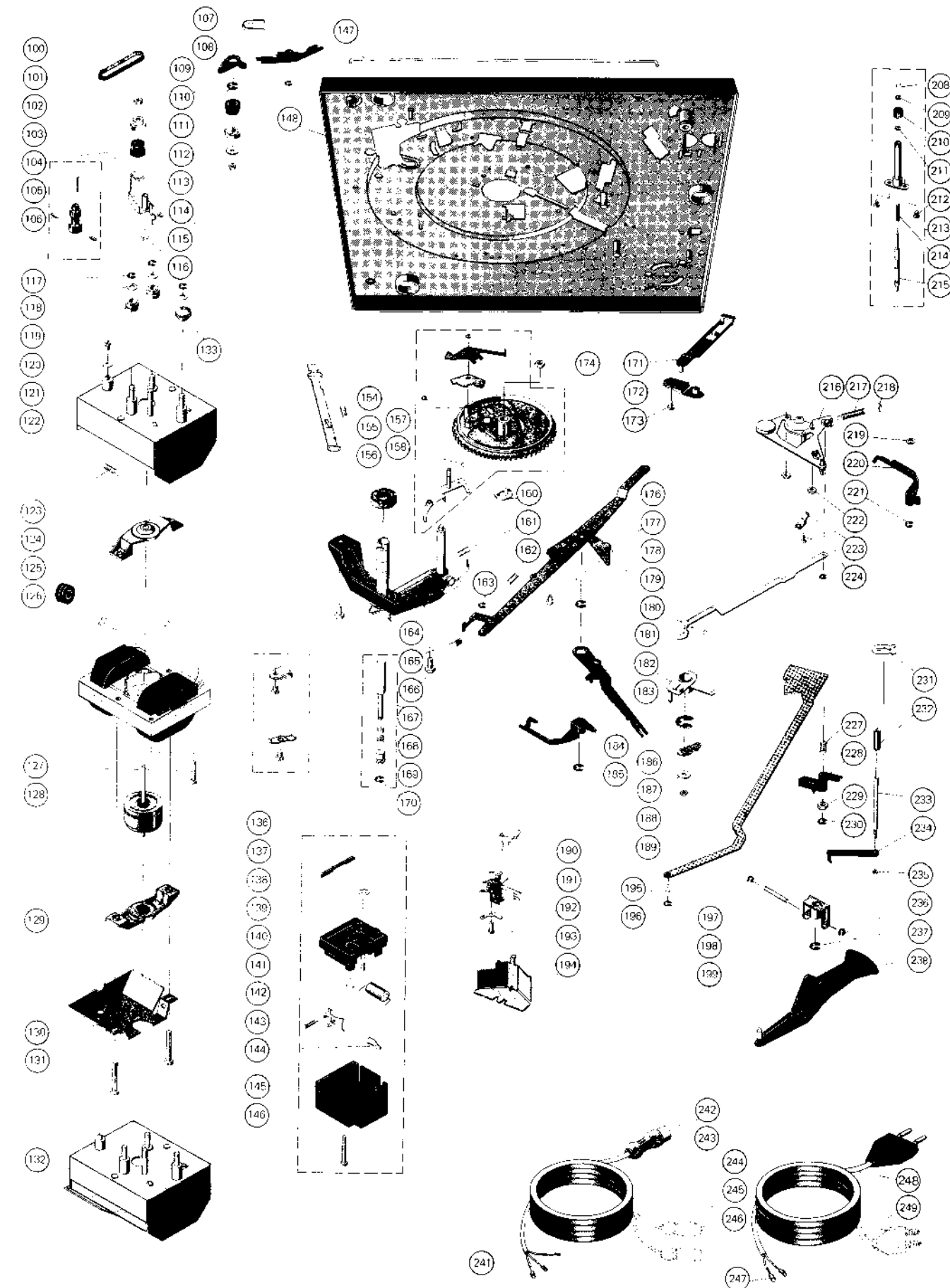
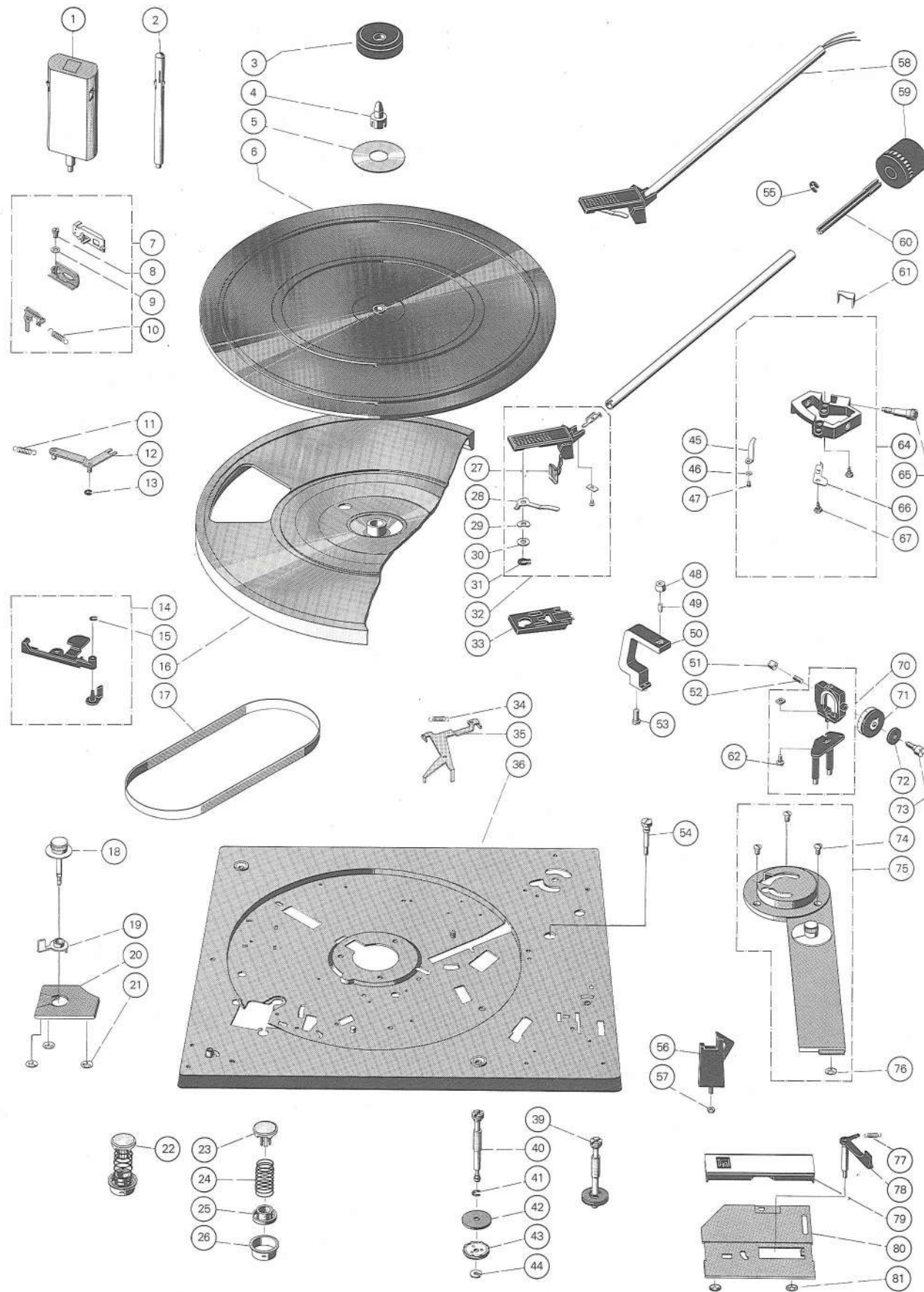

Fig. 21 Exploded view 1



Lubrication

All bearing and friction points of the unit are adequately lubricated at the works. Replenishment of oil and grease is only necessary after approximately 2 years of normal use of the record player as the most important bearing points (motor bearings) have sintered metal bushes.

Bearing points and friction faces should be lubricated sparingly rather than generously.

It is important that no oil grease should come in contact with the friction faces of the flat belt, drive pulley and flywheel rotor, otherwise slip will occur.

When using different lubricants, chemical decomposition can often take place. To prevent lubrication failure we recommend using the original lubricants stated below.

- 1 Wacker Siliconöl AK 300 000
- 2 Haftöl Renotac Nr. 343
- 3 BP Supper Viscostatik 10 W/40
- 4 Shell Alvania Nr. 2
- 5 Isoflex PDP 40
- 8 Molykote

Fig. 22

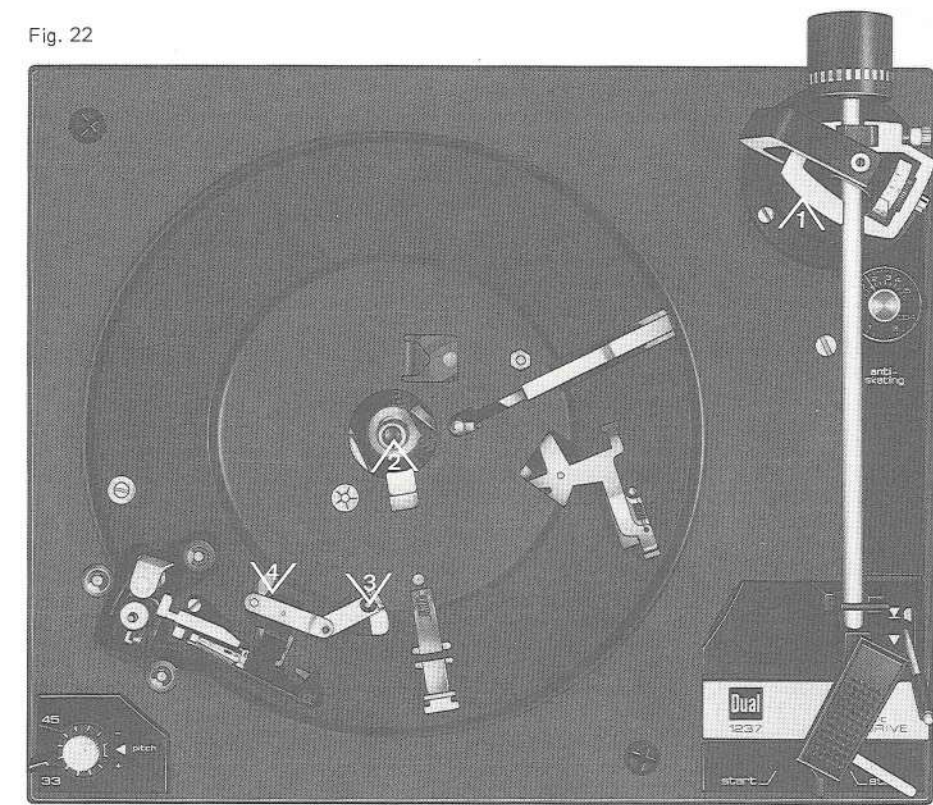
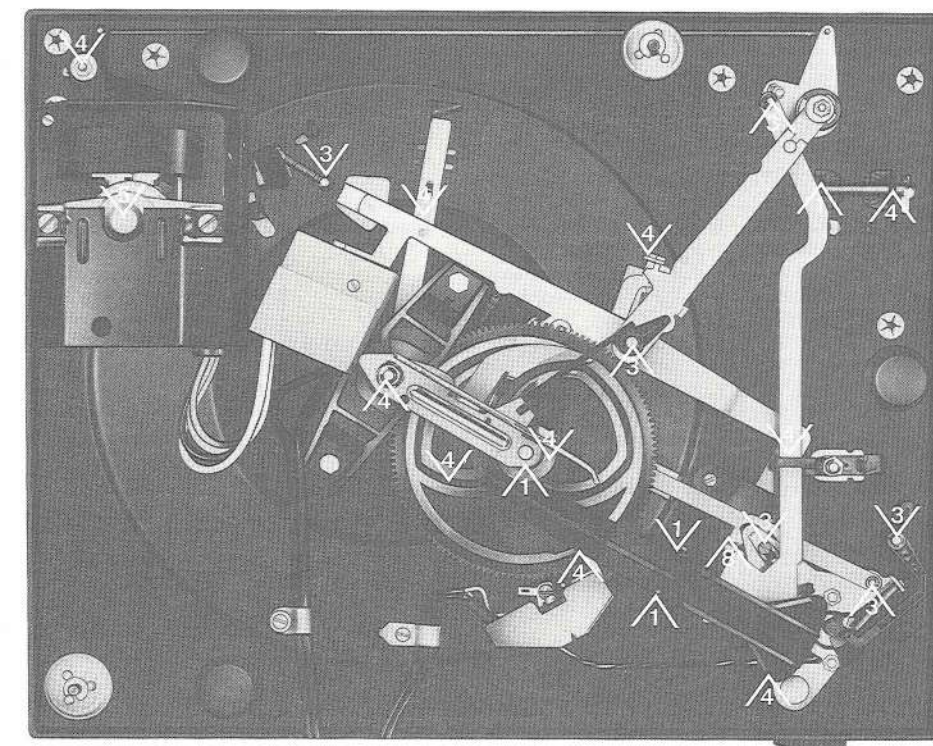

Fig. 23



Dual Gebrüder Steidinger · 7742 St. Georgen/Schwarzwald