



Edition July 1974

Dual 1228 Service Manual



Technical data

Current type	AC 50 or 60 cycle, with appropriate motor pulleys	
Line voltage	110/130 V and 220/240 V selector	
Drive	4-pole synchronous motor	
Power consumption	< 10 Watt	
Current requirements	approx. 64 mA at 220 V 50 cycle approx. 115 mA at 110 V 60 cycle	
Platter	non-magnetic 1.8 kg (4 lb) 270 mm (10.5 inch.) diameter	
Platter speeds	33 1/3 and 45 rpm, automatic tonearm setdown coupled to speed selector	
Pitch control	Adjustment of approx. 1 semi-tone (6 %) at both platter speeds	
Speed check	with light stroboscope for platter speeds of 33 1/3 and 45 rpm adjustable for 50 or 60 Hz	
Wow and flutter	< ± 0.09 % rated in accordance with DIN 45 507	
Signal-to-noise ratio	Rumble signal-to-noise ratio > 59 dB Rumble unweighted signal-to-noise ratio > 39 dB	in accordance with DIN 45500
Tonearm	Torsion resistant, aluminum tonearm in universal four-point gimbal suspension	
Tonearm bearing friction	vertical < 0.008 p horizontal < 0.016 p	
Pick-up head (cartridge holder)	Removable, suitable for acceptance of all cartridges having 1/2" mounting and a deadweight of 2 - 8 grams (including mounting fixtures)	
Stylus pressure	Continuously-adjustable from 0 - 10 p, reliable as from 0.5 p stylus pressure	
Pick-up cartridge	see separate data sheet	
Weight	4.3 kg	
Mounting dimensions and mounting board cut-out	see installation instructions	

Dual Gebrüder Steidinger · 7742 St. Georgen/Schwarzwald

Fig. 1 Pick-up Connection Diagram

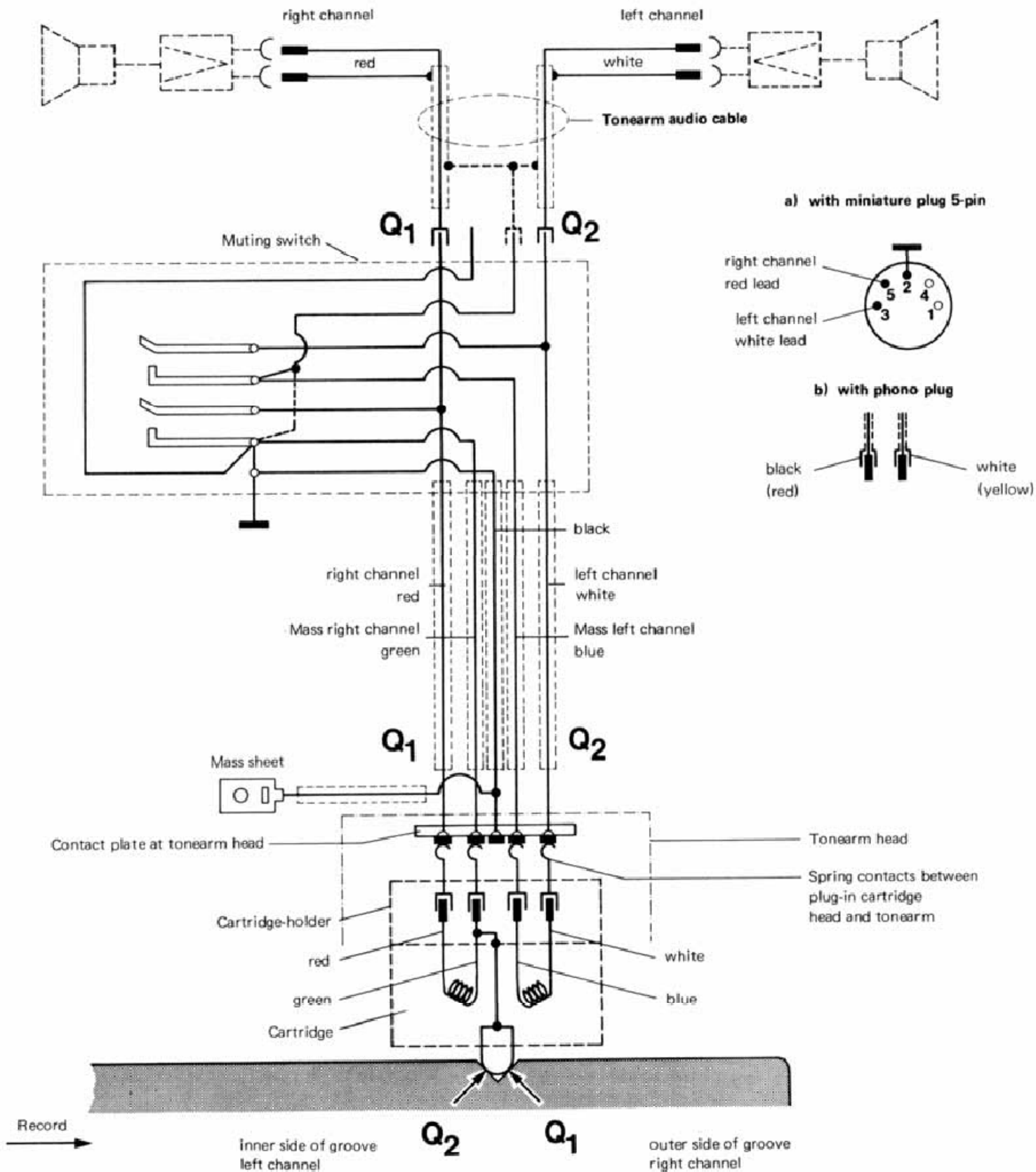

Contents

	Page
Technical Data	1
Pick-up Connection Diagram	2
Motor and Drive	4
Stroboscope	5
Pitch Control	
Correct nominal speed obtained only at extreme settings of pitch control	6
Platter does not run when unit is connected to power line and start switch operated	6
Platter does not reach required speed	6
Pick-up head not parallel to platter	6
Tonearm and Suspension	7
Anti-skating adjustment	8
Stylus slips out of playing groove	8
Vertical tonearm movement restricted during set-down	8
Tonearm Guide Mechanism	9
Tonearm Lift	9
Tonearm misses edge of record	10
Tonearm does not move onto record when drop cycle is started	10
Tonearm lowers too quickly when drop cycle is started	10
Tonearm returns to rest immediately after being placed on record manually	10
Start cycle	10
Manual Start	11
Stop Switching	11
Muting Switch	12
Record Drop	12
Shut-off and Change Cycle	12
Shut-off Mechanism	13
Platter stops after automatic set-down of tonearm	13
The last record of a stack keeps repeating	13
After adjusting the tonearm set-down point for 7" records the set-down point is not correct for 12" records	14
Record drops when unit is switched to "stop"	14
Records do not drop	14
Tonearm is hindered in its horizontal motion during change cycle	15
Tonearm moves with stylus force and anti-skating force at zero	15
Disturbing noises during change operation	15
No sound	15
Motor does not shut off	15
Acoustic feedback	15
Rumble in reproduction	15
Lubrication	16
Spare Parts with Exploded Views	17 - 22

Fig. 2 Motor suspension and platter drive

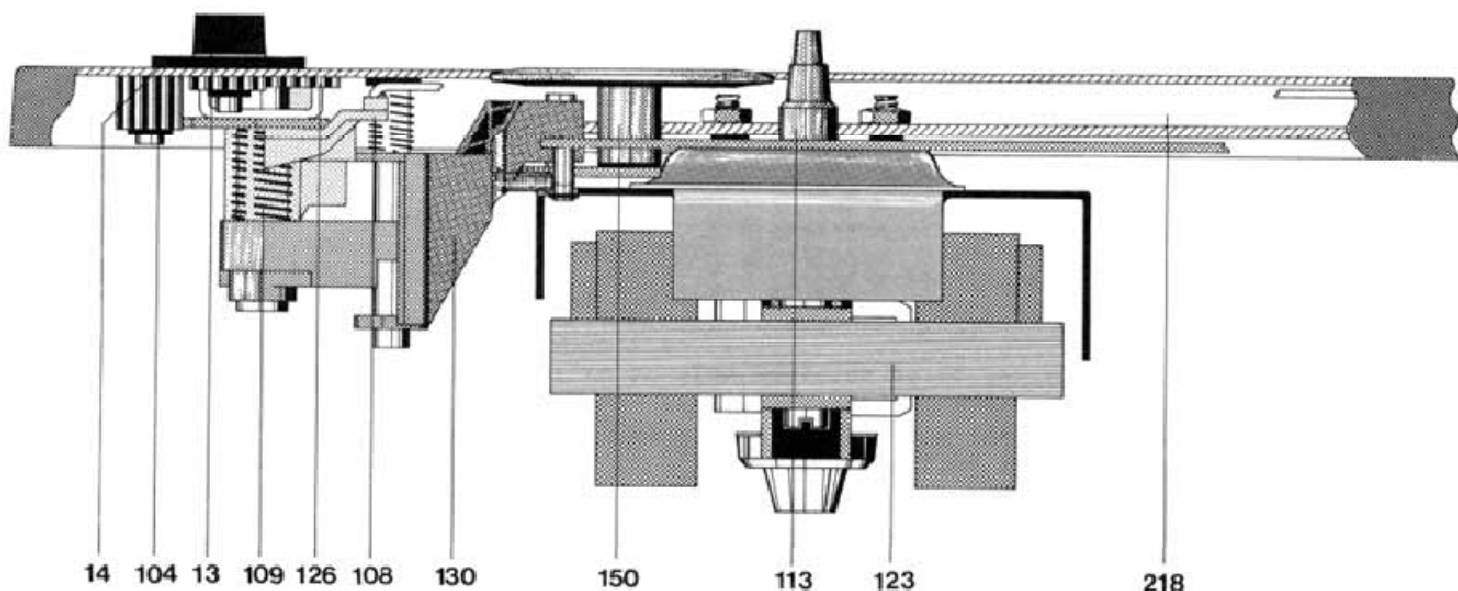

Motor and Drive

Power for the turntable platter and the changing mechanism is supplied by a four-pole, split-pole synchronous motor suspended by radially located elastic mounts and having a very small stray magnetic field as well as little vibration.

The speed of the motor is independent of line voltage, temperature or load variations. Speed is dependent on, and proportional to, power line frequency. The motor is adapted to 50 or 60 cycle (Hz) power line frequencies by the correct choice of the motor pulley.

Pulley for 50 Hz Art.-No. 232 900
 Pulley for 60 Hz Art.-No. 232 901

The motor pulley is secured to the motor shaft by a setscrew (114).

The platter is driven by the idler wheel (150) which is automatically disengaged from the motor pulley when the unit is shut off in order to protect its driving surface.

Platter speeds of $33 \frac{1}{3}$ and 45 rpm are selected by raising or lowering the idler wheel (150) to the appropriate step on the motor pulley.

When the selector lever (44) is moved, the selector segment (108) rotates. This causes the lever (130) fitted in the slot of the selector segment to move in a vertical direction. The idler wheel (150) mounted on the swinging arm (152) is lifted off the motor pulley and set down again on the motor pulley step for the appropriate speed.

Fig. 3 Motor field connections (with voltage selector)

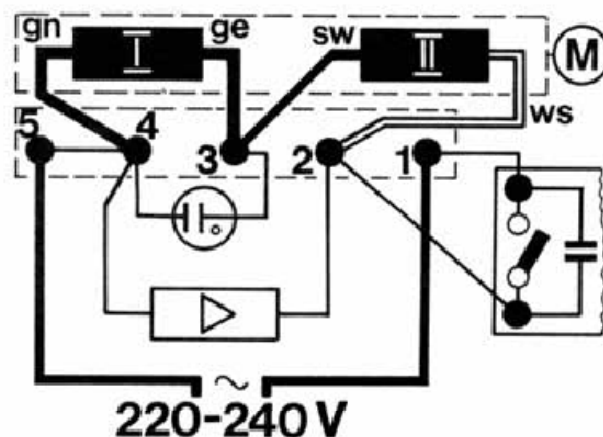
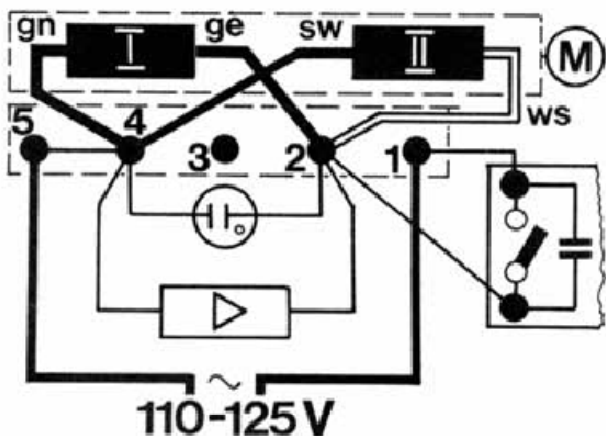

Stroboscope

The exact adjustment for the 33 1/3 and 45 r.p.m. can be done and controlled with the help of the strobe.

The ring of lines on the strobe will appear to stand still when the corresponding chosen speed (33 1/3 or 45 r.p.m.) rotates at the correct speed.

If the ring of lines move in the same direction as the turntable platter, the speed of the platter is too fast, when the lines move in the opposite direction of the platter, then the platter is rotating slower than the chosen speed.

The adjustment is made with the Var. Pitch knob (13).

To change the cylinder-head screws of the strobe, loosen then, strobe housing (74) on "50" or "60", push it and tight the screws again.

After removing the housing top (75) the glow lamp (77) can be changed. In the case of glow lamps with red spot ensure that the red spot (anode) locates on the left-hand contact spring (viewing the unit from the front).

Trouble

The strobe's neon lamp does not light up when the unit is turned on

Cause

- Defective neon lamp
- Current path is interrupted

Remedy

- Renew glow lamp (77). In the case of glow lamps with red spot, ensure that the red spot (anode) locates on the left-hand contact spring (viewing the unit from the front).
- Check the connection on the power supply switch and structure parts.

Fig. 4 Wiring diagram

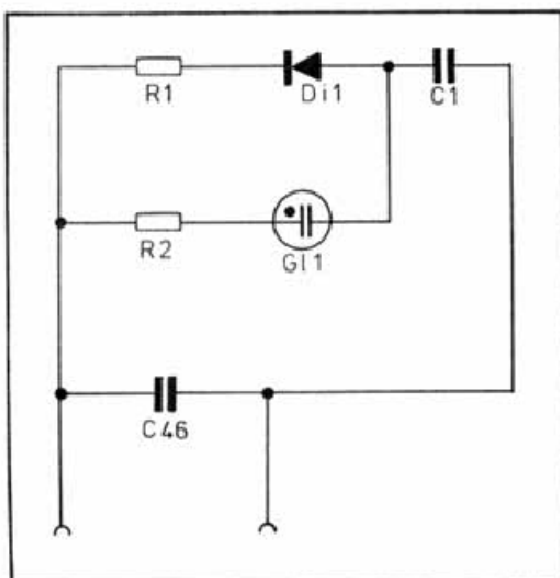

Fig. 5 Stroboscope

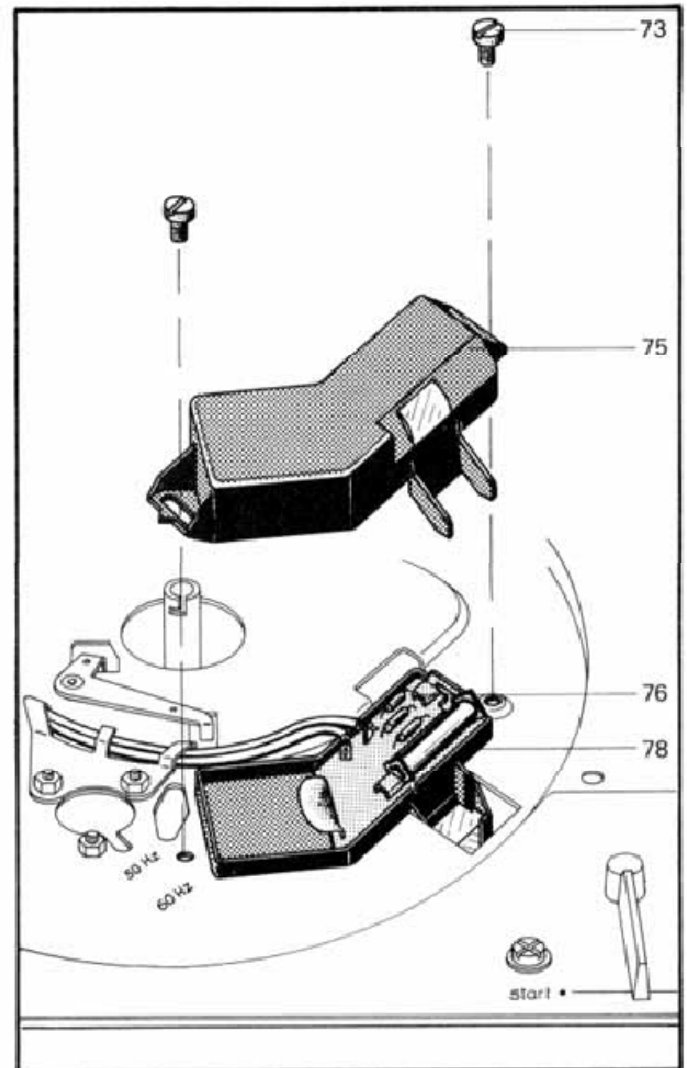

Fig. 6 Circuit board (output stages)

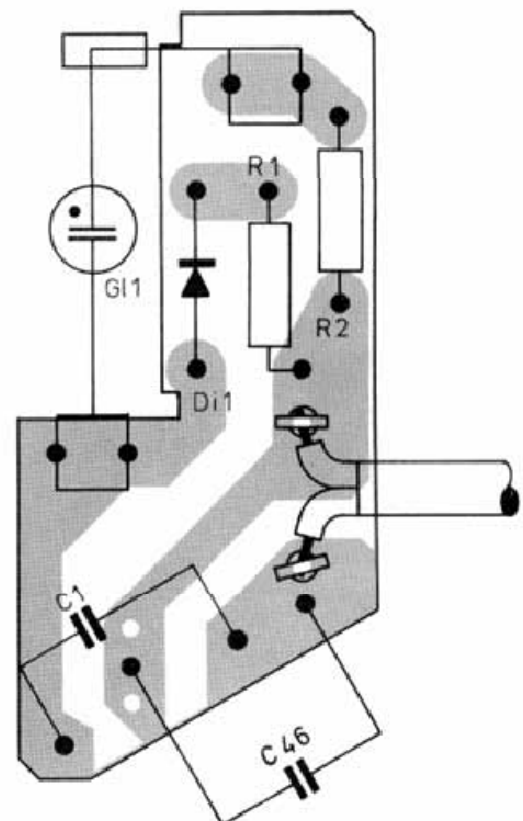
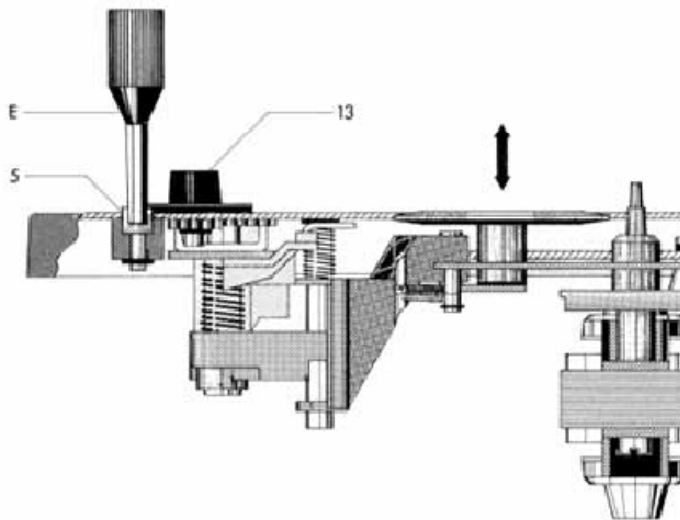

Fig. 7 Position of idler wheel



Pitch Control

For platter speeds of 33 1/3 and 45 rpm the unit incorporates a power-independent pitch control which permits a platter speed variation of up to 6 % (approximately one semi-tone).

When the pitch control knob (13) is turned, the switch segment (108) and the switch lever (130) attached to it are moved up or down. This vertical displacement changes the position of the idler wheel on whatever step of the motor pulley it has been placed, by the speed selector, and due to the tapered shape of the pulley effects approximately $\pm 3\%$ variation in speed.

Trouble

Correct nominal speed obtained only at extreme settings of pitch control

Platter does not run when unit is plugged in and start switch operated

Platter does not reach required speed

Cause

Idler wheel does not contact motor pulley correctly

- a) Current path to motor interrupted
- b) Idler wheel (150) not in contact with platter
- c) Motor pulley loose

- a) Motor pulley is not correct for local line frequency
- b) Slip between idler wheel (150) and motor pulley or platter

- c) Excessive friction in motor, idler wheel or platter bearings

Remedy

Turn adjustment screw (5) with knurled head control knob until nominal speed is reached when control knob (13) is in its center position

- a) Check connection at switch plate and voltage selector
- b) Check switch lever assembly (130)
- c) Tighten motor pulley

- a) Change motor pulley
- b) Clean friction surfaces of idler wheel, motor pulley and turntable platter. If necessary, replace idler wheel. Once the drive surface of the platter has been cleaned do not touch it with your fingers
- c) Clean and oil bearings

Fig. 8

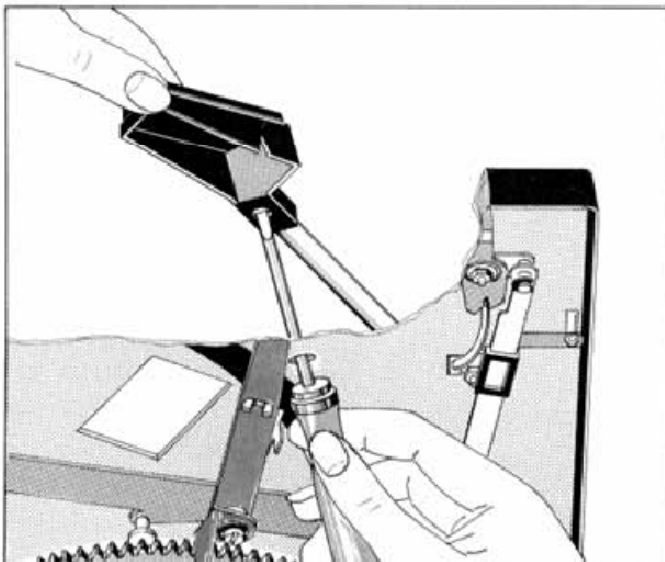

Trouble

Pick-up head not parallel to platter

Cause

The pick-up head has been moved out of position on the tonearm tube during transport

Remedy

Remove platter, with the aid of a screwdriver slacken screw on the pick-up head through the hole provided for this purpose in the chassis. After aligning the pick-up head retighten screw (Fig. 8).

Tonearm and Tonearm Bearing

The Dual 1228 has a light, torsionally rigid metal tonearm in a gimbaltype suspension. The actual support is provided by four hardened and precision-polished steel points resting in precision ball bearings. Tonearm pivot friction is thus reduced to a minimum.

Vertical pivot friction 0.008 gram
Horizontal pivot friction 0.016 gram

referred to stylus tip

It therefore guarantees exceptionally good tracking characteristics. The tonearm head is removable. Before setting the correct stylus force for the particular cartridge installed in the tonearm head, the tonearm should be balanced with the stylus force setting dial at the zero position. Coarse balancing is accomplished by sliding the counterweight (52) and using setscrew (53), after which a fine adjustment is made by turning the weight. The counterweight is proportioned so that cartridges with a weight of from 1 to 12 grams can be balanced. For the absorption of vibration and rapid small shocks, the counterweight is coupled to its threaded shaft through an elastic medium, and braked to prevent unintended rotation. The tonearm head accommodates all cartridges that conform to the internationally standard 1/2 inch mounting centers, and whose weight does not exceed 10 grams. Stylus force is set by turning spring housing (58), which is equipped with calibrations and which stresses or relaxes a spiral spring inside it. The scale is calibrated for a range of zero to 5 grams, and permits exact settings every 0.5 gram within that range.

To replace to tonearm complete with tonearm bearing, the following procedure is recommended:

1. Fasten complete unit in repair jig. Set stylus force to zero and lock tonearm.
2. Turn unit upside down, remove retainer spring (193) and unsolder tonearm leads.
3. Remove main lever (173).
4. Remove Tension spring (240) and Lock washer (235). Remove Skating lever (234).
5. Remove Lock washer (200) and slip plate (199). Remove shut-off (198), ensure ball (201) does not drop out.
6. Slacken hexagon nuts (236), remove segment (237), slacken hexagon nut (43) with washer (42), then remove tonearm.

When replacing the tonearm and bearing assembly, follow the procedure in reverse. The unit is first in the upright position. Insert the tonearm and lock it.

Turn unit upside down, fit washer (42) and hexagon nut (43). Place segment (237) in position and fit hexagon nuts (236).

To remove the tonearm from the bearing ring, after unsoldering the tonearm leads set the stylus force dial to zero. Unscrew locknut (38) with threaded rod (37) and bearing screw (64) (left-hand thread). Take tonearm carefully out of the bearing ring. For adjusting the tonearm head, a hole is provided in the chassis to make this possible without first removing the tonearm.

Adjustment of Tonearm Bearing

Both bearings afford a small, barely noticeable play. Adjustment of the vertical bearing should be undertaken only at the left screw (threaded rod 37), and of the horizontal bearing at threaded rod (39). The horizontal tonearm bearing is correctly set when, at an antiskating setting of "0.5" (tonearm previously exactly balanced), the tonearm glides smoothly from inside (center) to outside without binding.

Fig. 9 Tonearm bearing assembly

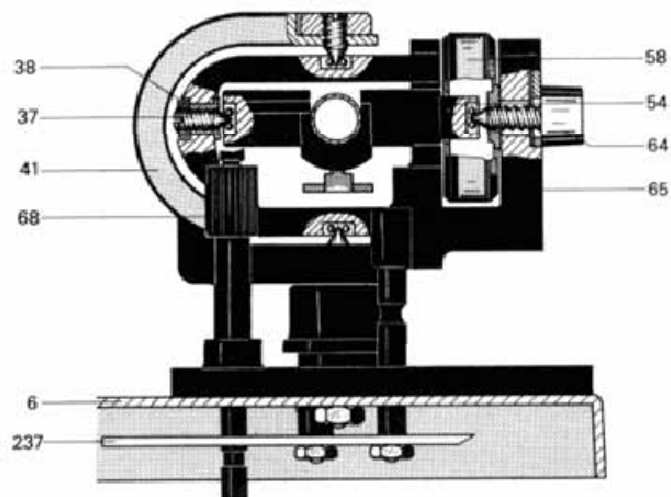

Fig. 10 Tonearm bearing assembly (view from underneath)

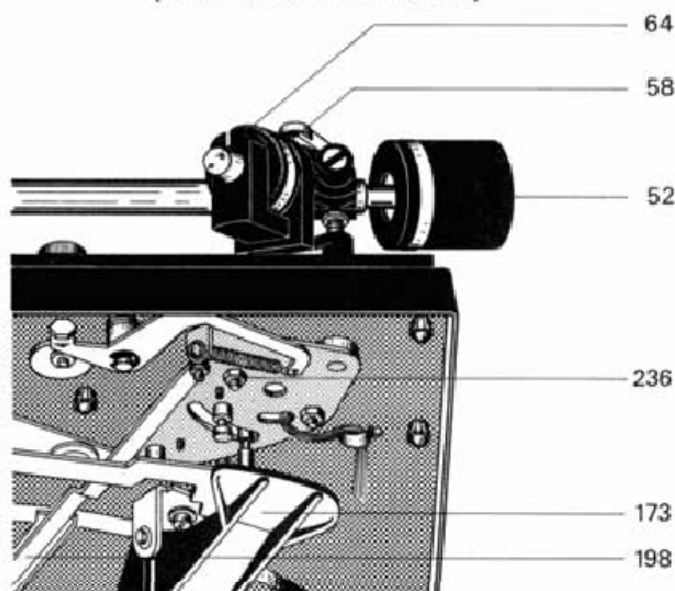
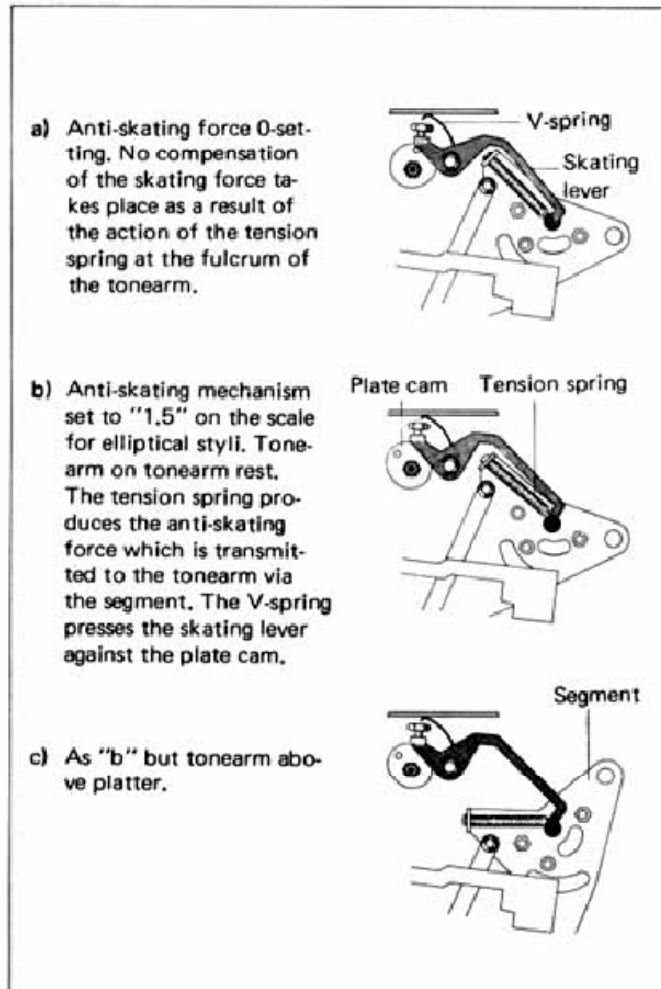

Fig. 11 Anti-skating force



Anti-Skating Device

The geometrically caused skating force acting on any tonearm is eliminated to a large extent in the case of the Dual 1228 by means of a precision antiskating device.

The skating force is dependent on the tonearm geometry, on the stylus force and the tip radius of the cartridge stylus. The inward pull of the tonearm caused by the skating effect leads not only to undesirable jumping of the tonearm when set down on the record but also unequal forces on the two opposite groove walls with resultant unfavourable effects. These can be corrected with the aid of a suitable anti-skating device. By turning the knob (70) of the anti-skating device located on the cover the asymmetrical plate cam (230) is moved. This plate cam has two different curvatures which, according to the different scales used, for spherical and elliptical tip styli and for CD 4 pick-up cartridges, move the skating lever (234) out of its position of rest and transmit the counter force to the tonearm by means of the tension spring (240).

Skating adjustment is set at the works for conical styli with a tip radius of $15 \pm 2 \mu\text{m}$ and for elliptical styli with measurements of $5/6$ and $18/22 \mu\text{m}$ and also for CD 4 cartridges. The hexagon nut (231) is firmly tightened and locked with paint. Readjustment should only be attempted with the aid of the Dual Skate-0-Meter and the L 096 test record. This is best done by an authorised Dual service station.

Trouble

Stylus slips out of playing groove

Cause

- Tonearm not balanced
- Tonearm contact pressure insufficient
- Antiskating adjustment incorrect
- Stylus point worn or splintered
- Excessive bearing friction in tonearm bearing

Remedy

- Balance tonearm
- Check tonearm balance, set contact pressure to value stated by cartridge manufacturer
- Correct anti-skating adjustment
- Renew stylus
- Check tonearm pivot. Should have barely noticeable play. Adjust vertical bearing only with the left bearing screw (37) and the horizontal bearing with nut (39). Horizontal bearing is correctly adjusted when the tonearm, with anti-skating set at 0.5 gram, swings freely from center to rest.
- Renew steel ball (201)

Vertical tonearm movement restricted during set-down cycle

- Steel ball (201) of shut-off slide missing

- Excessive bearing friction
- Lift pin sticks in lift tube

- Eliminate friction by adjustment of bearing screw (setscrew 37) and check balance
- Remove tonearm complete with bearing assembly (described on page 7). Remove guide (66) on lift pin (243). Remove lockwasher (67) detach adjuster sleeve (68) and remove second lockwasher (67). Remove lockwasher (224) on adjuster lever (221). Detach positioning slide from pin on adjuster lever, retract until lift pin (249) is released. Remove lift pin. Clean lift tube and lift pin. Smear lift pin evenly with "Wacker silicone oil AK 500 000". Reassemble components.

Tonearm Guide Mechanism

A guide groove located on the underside of the main cam (161) controls the automatic lift and set-down of the tonearm as the cam rotates through 360°. Tonearm lift and lowering are controlled by main lever (173) and lift screw (243). Horizontal movements are controlled by the main lever (173) and the segment (237).

Automatic tonearm set-down is designed for 12" and 7" records and is coupled to the platter speed selector. Set-down points are determined by the spring pin of segment (237) contacting the positioning slide (219) which is only raised by the main lever (173) during the change cycle and thus moves within reach of the spring pin fitted on the segment. On completion of set-down or change cycle (tonearm sets down on the record) the positioning slide (219) is released again and returns to its normal position. It thus moves out of reach of the spring pin permitting the tonearm to move horizontally without hindrance while playing the record.

Fig. 12 Tonearm guide mechanism

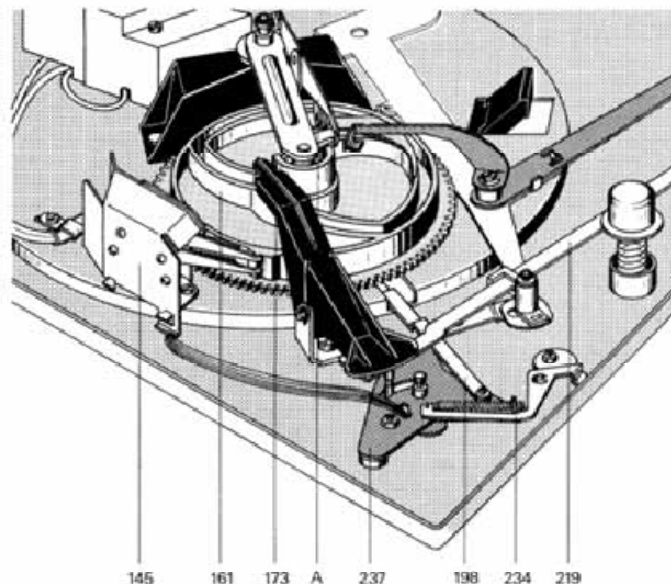

Tonearm Lift

The tonearm lift permits the tonearm to be set down on the record safely at any desired point outside the shut-off area.

Moving the tonearm lift handle (49) forward causes lift cam (227) to rotate. This movement is transmitted via positioning slide (219) to the lift pin which then raises the tonearm.

After moving the tonearm (by hand) to the desired spot on the record the tonearm lift handle is tapped lightly (to the rear) to release the mechanism.

The positioning slide (219) is thus released and the tonearm descends slowly, controlled by the viscosity damped lift pin.

The height of the stylus above the record can be varied from zero to 6 mm by turning adjuster screw (48). Turning to the right increases the height, turning to the left reduces the height.

Fig. 13 Tonearm lift (tonearm raised)

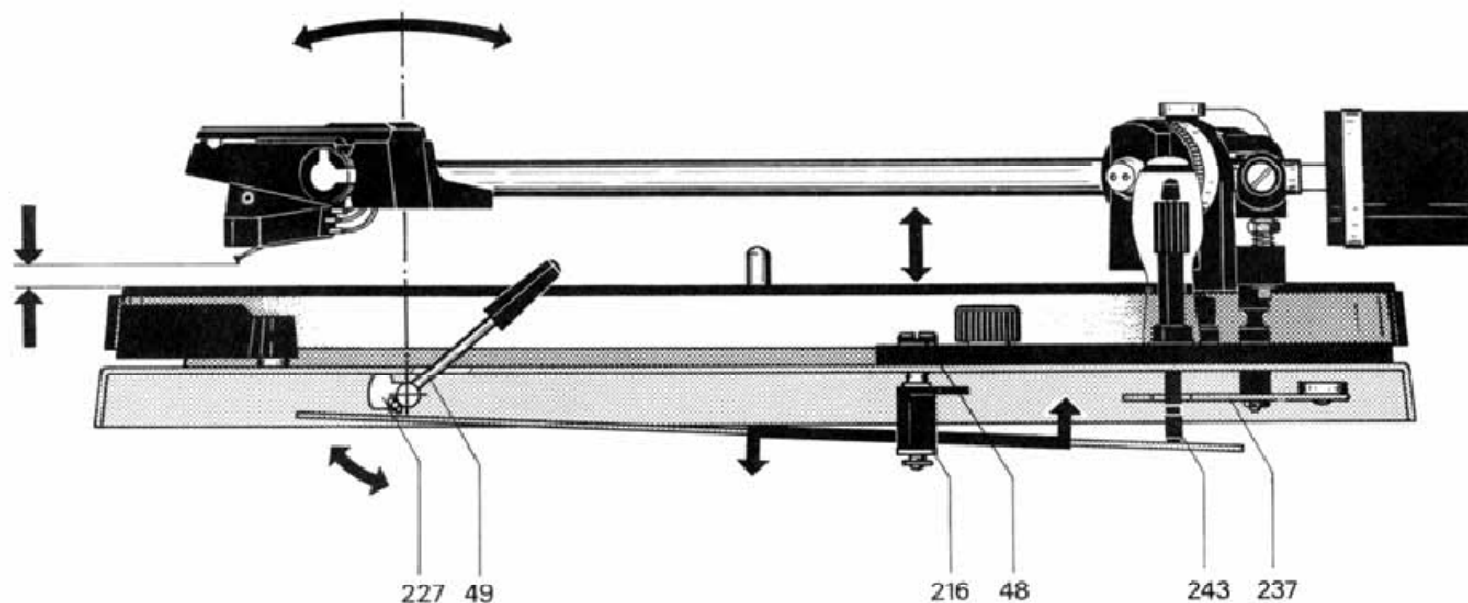

Trouble	Cause	Remedy
Tonearm misses edge of record	a) Set-down point incorrectly adjusted b) Record not standard size c) Friction surfaces of tonearm clutch dirty	a) Set right-hand selector lever to "45". With a screwdriver inserted through the hole exposed turn eccentric pin until the tonearm sets down approximately 1.5 mm from the edge of the record. (Adjustment is only carried out for 7" records and is then automatically correct for 12" records). b) Use standard record c) Clean clutch surfaces
Tonearm does not move onto record when drop cycle is started	Excessive damping caused by dirt in silicone oil in lift tube	Remove tonearm complete with bearing assembly (described on page 7). Remove lift pin and clean (described on page 8).
Tonearm lowers too quickly when drop cycle is started	Insufficient damping caused by improper addition of lubricant to damping compound	Remove tonearm complete with bearing assembly (described on page 7). Remove lift pin and clean (described on page 8).
Tonearm returns to rest immediately after being placed on record manually	Shut-off mechanism has sifted out of position during shipping	Before using changer after moving, run it through start cycle with tonearm locked on rest (selector moved to "start")

Fig. 14 Start position

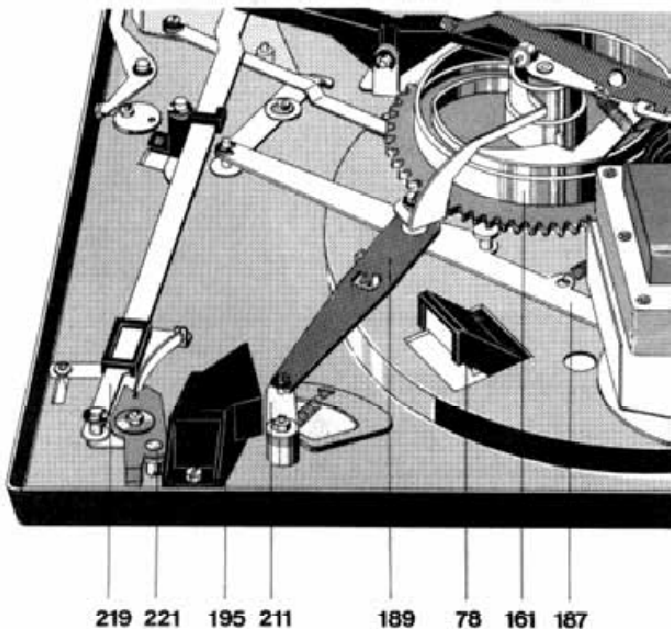

Start Cycle

Moving the start switch (44) causes change lever (189) to rotate outwards. This initiates the following functions:

- a) A lug rotates shift arm (187). The latter in turn by means of a tension spring moves the change lever (189) and thus the idler wheel (150) into engagement with motor pulley (113) and platter (12). At the same time the power switch (140) is actuated by the switch slide (181) coupled to the shift arm and the platter starts to rotate.
- b) Change lever (189) is brought within reach of the cam follower lever (166) so that the latter is pushed into the change position after subsequent rotation of the main cam.

Moving the operating switch (44) also releases the start level (185) which is pulled towards the main cam by means of tension spring (184). By this means the shut-off lever (158) is moved within the range of the dog on the platter pinion thus driving the main cam. The change lever (189) is also locked. To prevent malfunctions the operating switch is locked in position during the start cycle (rotation of the main cam). Just before the main cam reaches neutral position (at the end of the change cycle) the start lever is pushed clear by the main cam and thus the operating switch and change lever are returned to their original positions. After installation and after moving the changer the unit should be started with the tonearm locked on the rest. This will automatically readjust the shut-off lever which may have shifted out of position.

Fig. 15 Stop position

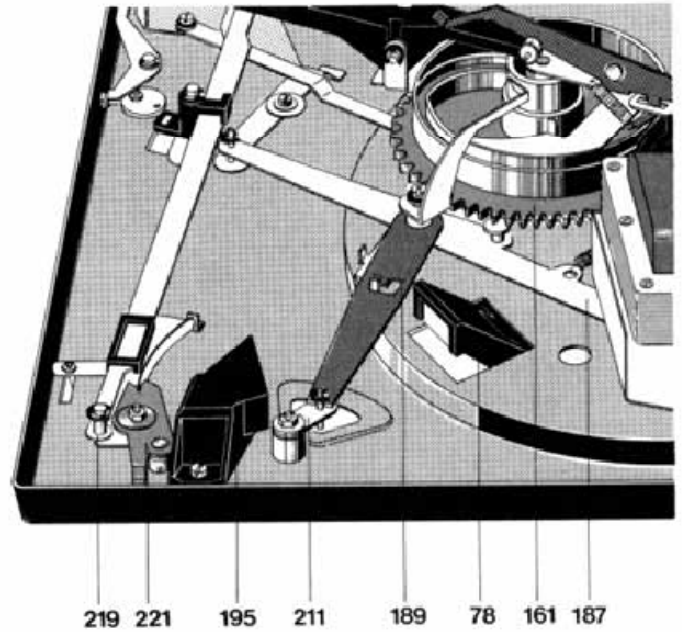

Manual Start

When the tonearm is swung inwards by hand the pawl (203) on the shift arm (187) engages on a square end pin fitted in the chassis, retaining the shift arm in this position and thus the idler wheel (150) in engagement with the platter.

The slide (181) linked to the shift arm actuates the power switch and sets the platter in motion.

On reaching the run-out groove the tonearm automatically returns to its rest position and the unit shuts itself off. If, however the tonearm is lifted off the record before completion of play and returned to the rest, the pin of segment (237) releases the pawl (203). The tension spring then returns the shift arm to its initial position, opening the power switch and disengaging the idler wheel.

Fig. 16 Muting Switch

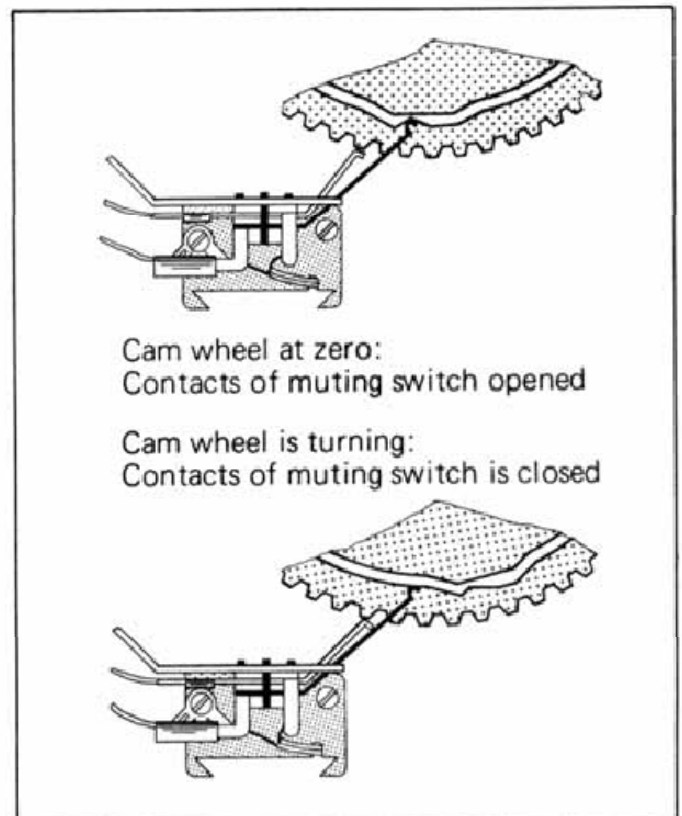

Stop Switching

When the operating lever is moved to "stop" only the starting lever (181) is drawn forward. As a result, the shut-off linkage engages with the main cam. The cam follower lever remains in stop position.

When the tonearm is on its rest and the operating lever is pushed to "stop", the change lever must not jam.

Fig. 17 Record Drop

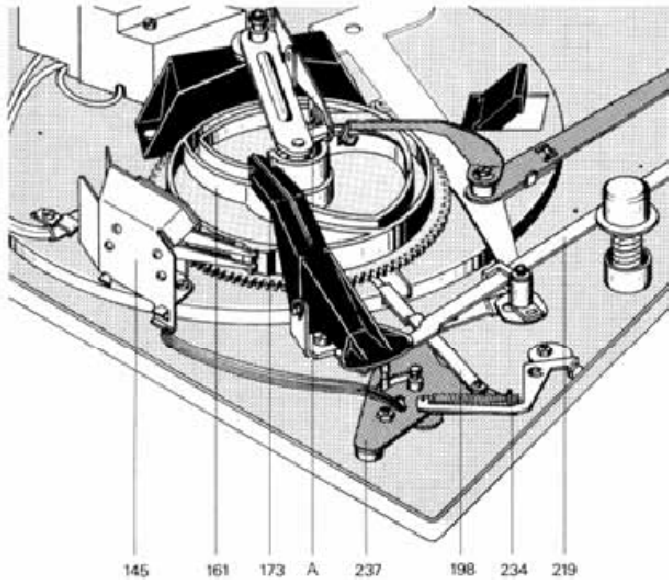

Short Circuiter

To prevent disturbing noise during the change cycle and during automatic operation of the tonearm the unit is fitted with a muting switch. Control of the switch springs for both channels is effected by the main cam. With the unit in position of rest the muting switch is opened.

Record Drop

Insert the appropriate spindle - AU 3 for standard records (7 mm center hole) or AS 12 for 45 rpm records (38 mm center hole).

Record drop is initiated by rotation of the main cam (161) whose cam surface guides the cam rocker (A) and the change actuator stud (177). The resultant downward movement initiates record drop via the changing spindle or automatic spindle.

The record drop cam is located on the main cam so that record drop can only take place when the tonearm is over the tonearm rest, that is to say, out of reach of the largest possible records (12" diameter).

Fig. 18 Actuating "change" or "shut-off"

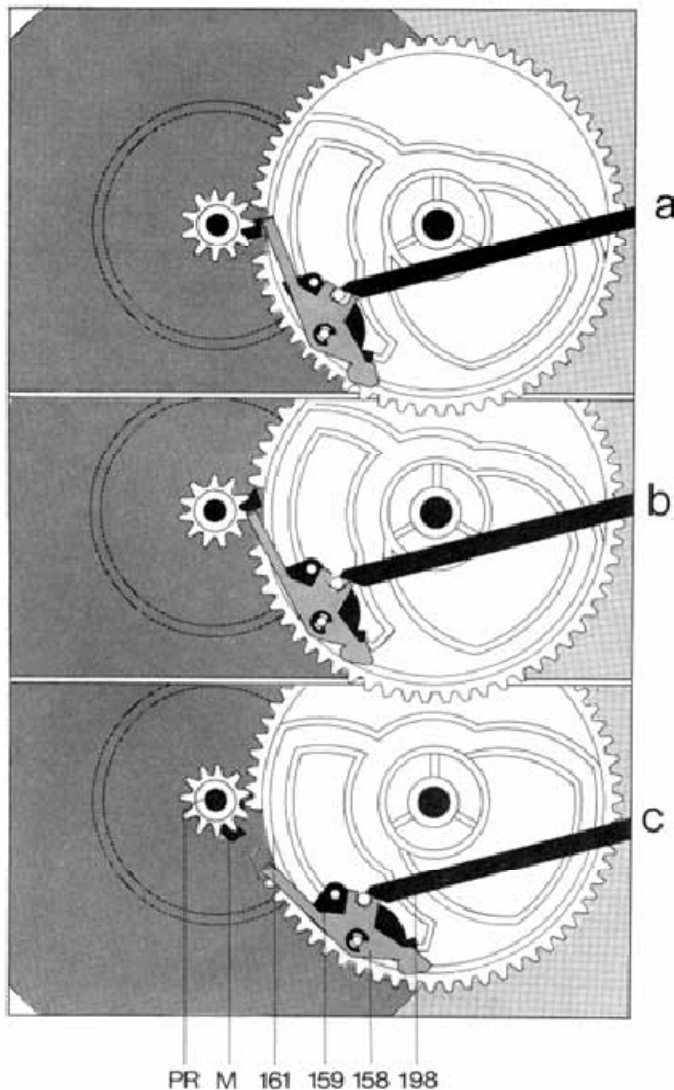

Shut-off and Change Cycle

The dog (M) of platter pinion (PR) and shut-off lever (158) actuate both the change cycle at the end of the record and shut-off after the last record in a stack is played.

At the end of a record the tonearm moves towards the center at an accelerated rate due to the increased pitch of the grooves. This motion carries shut-off lever (158) towards the dog by means of shut-off slide (198). The eccentric dog pushes the shut-off lever (158) back at each revolution as long as the tonearm advance is only one normal record groove. (Fig. 18 a)

The run-out groove with its steeper pitch moves the shut-off lever (158) against the dog with greater force so that the shut-off lever is picked up and moves with it. (Fig. 18 b)

The main cam (161) is thus moved out of its neutral position into engagement with the pinion of the platter. (Fig. 18 c)

Shut-off Mechanism

The shut-off and change functions are determined by the position of the cam follower lever (166). After every start or record drop the cam follower lever (166) is moved to stop position by main lever (173) (longer end of the cam follower lever towards the center of the main cam).

As the record is dropped the cam follower lever (166) is turned to start position by cam rocker (A) so that the tonearm can swing in after record drop and be lowered onto it. If there are no more records on the spindle its downward movement is locked and the cam rocker cannot turn the cam follower lever, the lever remains in stop position and causes the tonearm to lower onto its rest.

When main cam (161) returns to neutral position the lug of shift arm (187) is able to move into the recess provided in the main cam, actuate power switch (140) and disengage idler wheel (150).

Fig. 19 Change Cycle

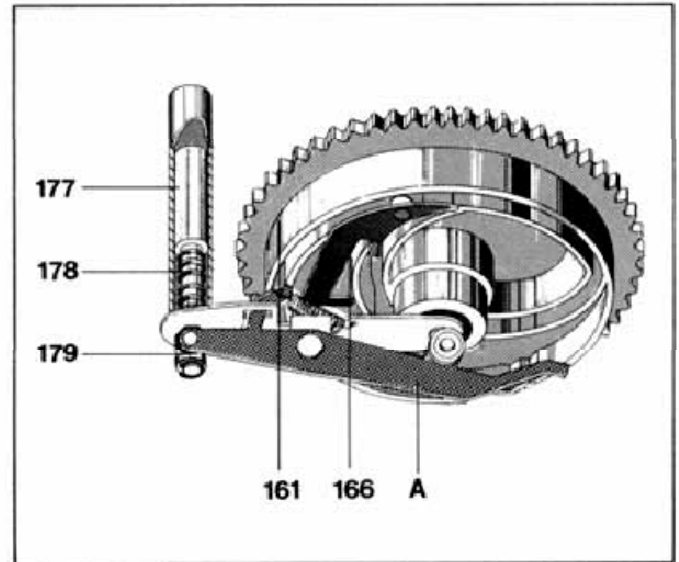
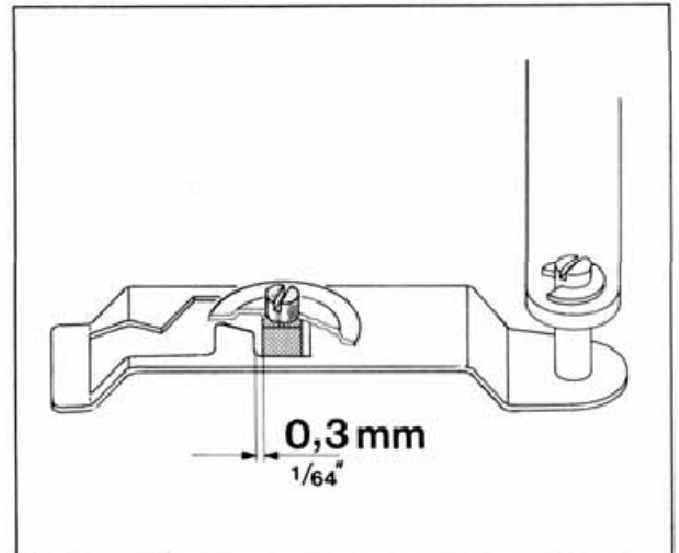

Fig. 20



Trouble

Platter stops after automatic set-down of tonearm

Cause

- a) Shift arm (187) not locked by pawl (203).
- b) Power switch has interrupted power supply (has switched off)

Remedy

- a) By turning the eccentric pin on the pawl
- b) By adjusting switch slide (181) maximum play between switch slide and shift arm (0.3 mm).

Fig. 21

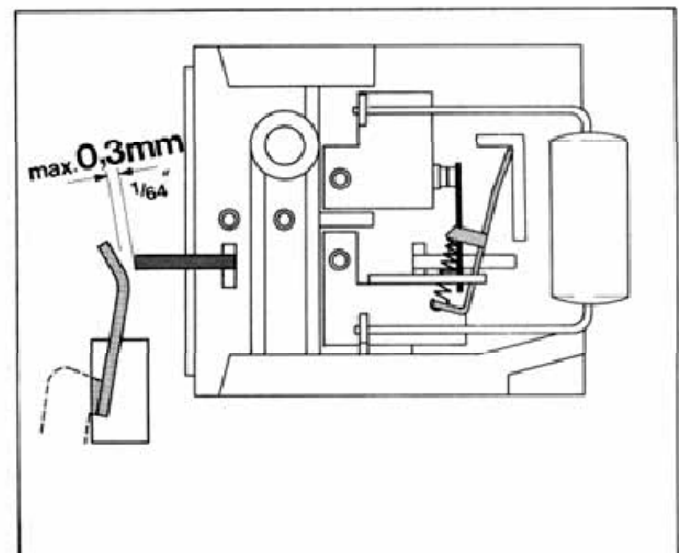

Trouble

The last record of a stack keeps repeating

Cause

Defective spindle

Remedy

Replace spindle

Fig. 22

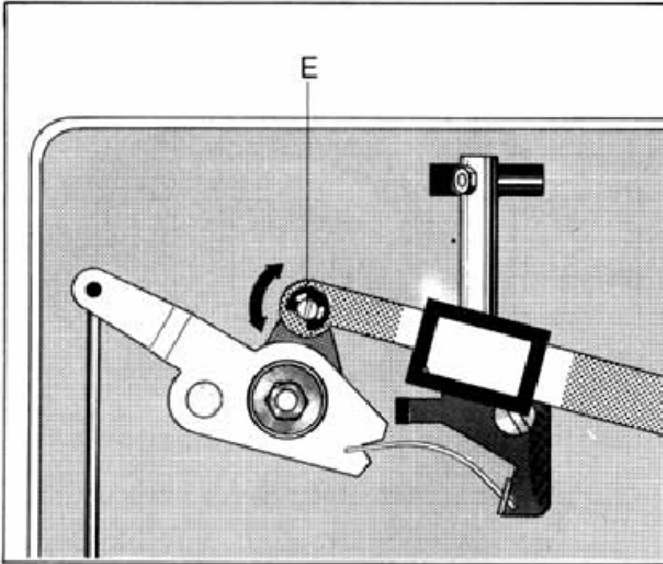

Trouble

After adjustment of the tonearm set-down point for 7" records the set-down point for 12" records is incorrect

Cause

Eccentric pin (E) of adjuster lever (221) out of adjustment

Remedy

Adjust tonearm set-down point by turning eccentric pin (E)

Fig. 23

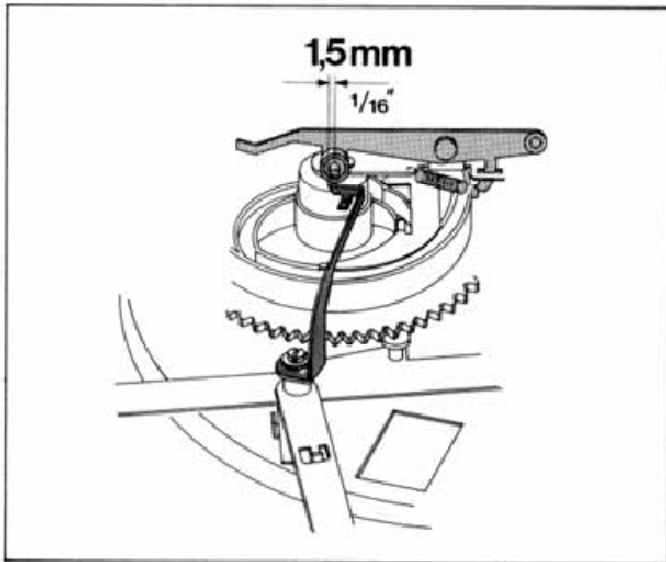

Trouble

Record drops when unit is switched to "stop"

Cause

Cam rocker (A) not locked by change lever

Remedy

Adjust change lever so that it passes approximately 1.5 mm underneath the cam rocker when "stop" function is initiated

Fig. 24

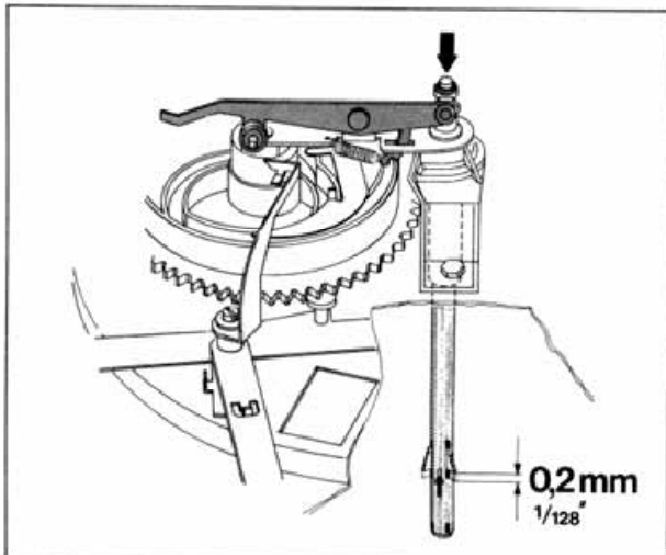

Trouble

Records do not drop

Cause

Cam rocker has insufficient travel

Remedy

Adjust travel with eccentric screw on cam rocker. Adjustment is correct when, with the main cam in neutral position and the changing spindle locked, the three supports of the changing spindle describe longitudinal movement of 0.2 mm when the change actuator stud is pushed up

Trouble

Tonearm is hindered in its horizontal motion during change cycle

Cause

Positioning socket or positioning screw misadjusted

Remedy

Move tonearm over operating lever (44) and turn the positioning socket (68) until the clearance between stylus tip and operating lever is approximately 2 - 3 mm (Fig. 25).

Rotate cam (161) away from its neutral position until main lever (173) lifts the tonearm completely.

Swing the tonearm over its rest and adjust nut (60) so that between guide (66) and the resting surface of the tonearm there is a play of approximately 0.1 mm (0.5 mm measured at tonearm head.).

Caution

This play must be maintained over the entire horizontal swing.

Fig. 25

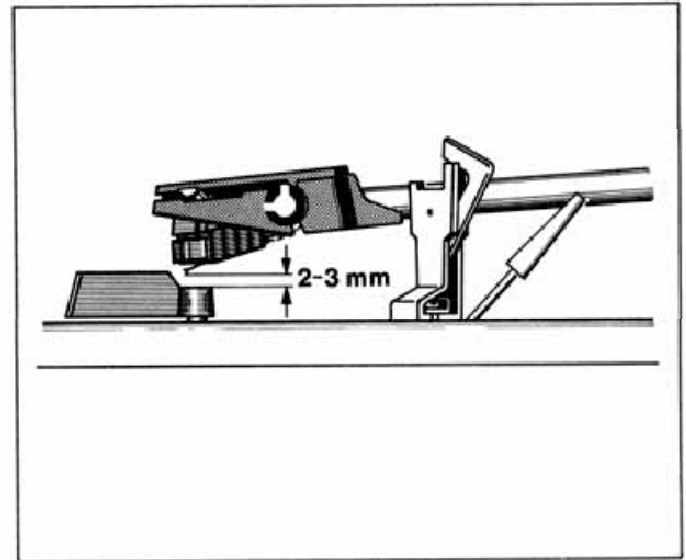
**Trouble**

Tonearm moves with stylus force and anti-skating force at zero:

- a) outward
- b) inward

Cause

a) Anti-skating out of adjustment

b) Too taut tonearm leads produce a twisting force

During change, start and stop operations, noise from the mechanism can be heard in speaker system

Muting switch maladjusted. Clearance between contact strips on muting switch excessive

No sound. The short circuit of the pick-up leads is no longer broken

Clearance between wipers and contact strips absent or insufficient

Motor will not shut off when tonearm is on arm rest

Suppression capacitor (in power switch) is defective (short circuit)

Acoustic feedback

- a) Chassis parts (e.g. connection leads) are touching base cutout
- b) Connection leads are too taut

Rumble in reproduction

Worn idler wheel

Remedy

a) Adjust skating lever so that horizontal movement of tonearm causes no movement of anti-skating spring.

b) Allow some black in tonearm leads

By bending contact strips. Adjustment is correct when, with the main cam in neutral position, the gap between the wipers and the contact strips on the muting switch is approximately 0.5 mm. Spray contact springs with preservative (e.g. Kontakt 61) and check adjustment of contact strips

By adjusting contact strips. Adjustment is correct when, with the main cam in neutral position, the gap between the wipers and the contact strips on the muting switch is approximately 0.5 mm

Renew suppression capacitor in power switch

a) Correct cutout according to instructions supplied with unit. Move leads

b) Slacken or extend leads

Replace idler wheel (150) and clean platter drive surface and motor pulley with greaseless solvent. Once surfaces are cleaned, do not touch them with your fingers.

Fig. 26 Lubrication points above chassis

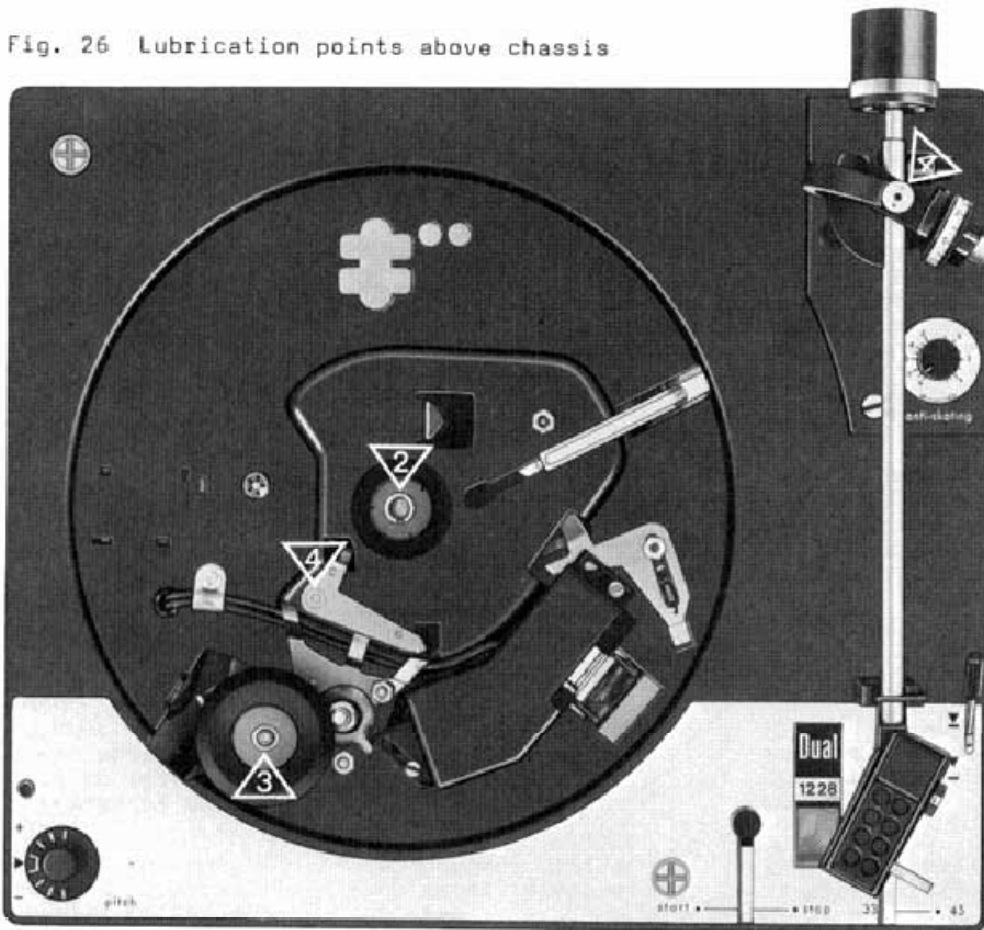

Lubrication

All bearings and friction surfaces have been adequately lubricated at the works. Replenishment of oil and grease is only necessary after about 2 years with normal use as the most important bearing points (motor bearings) are fitted with sintered metal bushes.

Lubricants should be applied sparingly to bearing points and friction surfaces. It is important that no oil or grease should come in contact with the friction faces of the idler wheel, motor pulley and platter as otherwise slip will occur. Avoid touching these parts for the same reason.

When lubricants of different types are mixed, chemical decomposition frequently occurs.

To avoid complications with lubricants we recommend using the original lubricants listed below.

The following lubricants should be used:

Fig. 27 Lubrication points below chassis

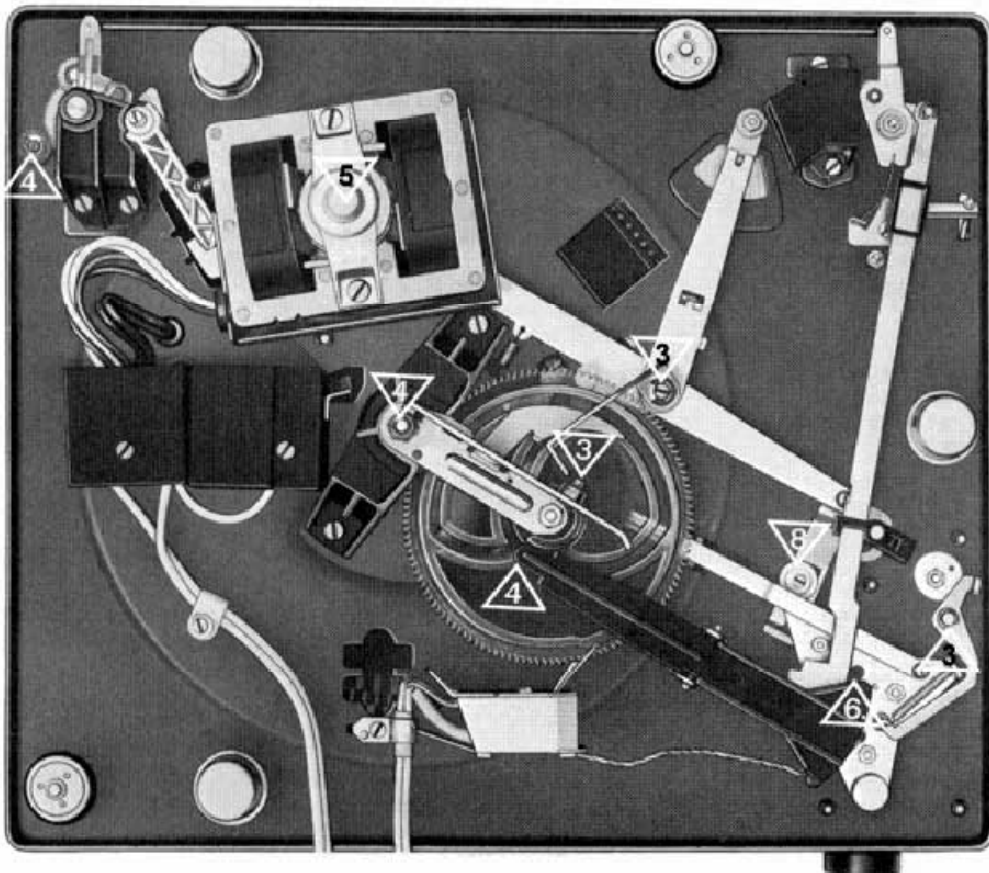

2 Renotac No. 342 adhesive oil

3 BP Super Viscostatic 10 W/30

4 Shell Alvania No. 2

5 Isoflex PDP 40

6 Silicone oil AK 500 000

8 Molykote

Replacement Parts

Pos.	Part.-No.	Description	Quantity
1	215 470	Automatic spindle AS 12	1
2	213 895	Automatic spindle AW 3	1
3	220 213	Centering piece	1
4	201 101	Centering pin	1
5	228 111	Adjusting screw	1
6	223 245	Chassis complete	1
7	230 670	Cable support	1
8	214 056	Washer	1
9	200 543	Retaining ring	1
10	229 776	Ring	1
11	233 236	Turntable mat compl.	1
12	233 237	Turntable compl. with mat	1
13	229 743	Knob	1
14	229 733	Scale ring	1
15	230 529	Threaded piece	3
16	230 523	Compression spring	3
17	200 723	Rubber damping block	3
18	200 722	Steel cup	3
19	232 975	Spring mounted footing compl.	3
20	232 976	Tonearm head compl.	1
21	231 992	Contact plate compl. with mass sheet	1
22	201 132	Lift	1
23	210 182	Bowed lockwasher 4.2/8	1
24	210 630	Washer 4.2/8/0.5 St	1
25	210 197	Ring 4/0.8	1
26	223 036	Cartridge mount TK 15 compl.	1
27	232 978	Tonearm rest compl.	1
28	210 361	Hex nut BM 3	3
29	200 718	Compression spring	2
30	210 624	Washer 4.2/7/0.3 St	4
31	201 632	Rubber washer	2
32	200 713	Washer	2
33	200 712	Spring cup	2
34	200 711	Lockwasher	2
35	214 047	Spezial screw	2
36	214 210	Shipping screw compl.	2
37	221 486	Set screw	1
38	216 831	Lock nut	1
39	230 063	Set screw	1
40	227 589	Locknut	1
41	233 226	Frame compl.	1
42	210 643	Washer 4.2/12/1 St	1
43	210 366	Hex nut BM 4	1
44	230 891	Switch lever compl.	2
45	230 668	Cover prism	1
46	230 669	Frame for cover prism	1
47	233 234	Blind 1228	1
48	229 631	Adjusting screw	1
49	229 745	Lever compl.	1
50	210 353	Hex nut BM 2	1
51	233 233	Tonearm compl.	1
52	233 246	Weight compl.	1
53	230 531	Stud	1
54	233 257	Bearing compl.	1
55	227 569	Clamp bolt	1
56	230 859	Square head bolt	1
57	230 978	Extension screw	1
58	233 244	Spring housing compl.	1
59	230 540	Clamp	1
60	229 723	Adjusting screw	1
61	232 068	Compression spring	1
62	218 043	Washer 3.2/7/0.5 St	1
63	229 720	Needle	1
64	229 738	Bearing screw compl.	1
65	233 227	Bearing	1
66	216 844	Guide	1
67	210 143	Lockwasher 1.5	2
68	218 318	Positioning sleeve	1
69	210 469	Machine screw AM 3 x 3	3
70	229 794	Antiskating knob compl.	1
71	233 004	Dress plate	1
72	213 260	Pin	4
73	210 472	Machine screw AM 3 x 4	5
74	233 228	Housing, compl.	1
75	233 231	Housing, top	1
76	233 229	Wiring board compl.	1

Fig. 28 Exploded view, parts above chassis

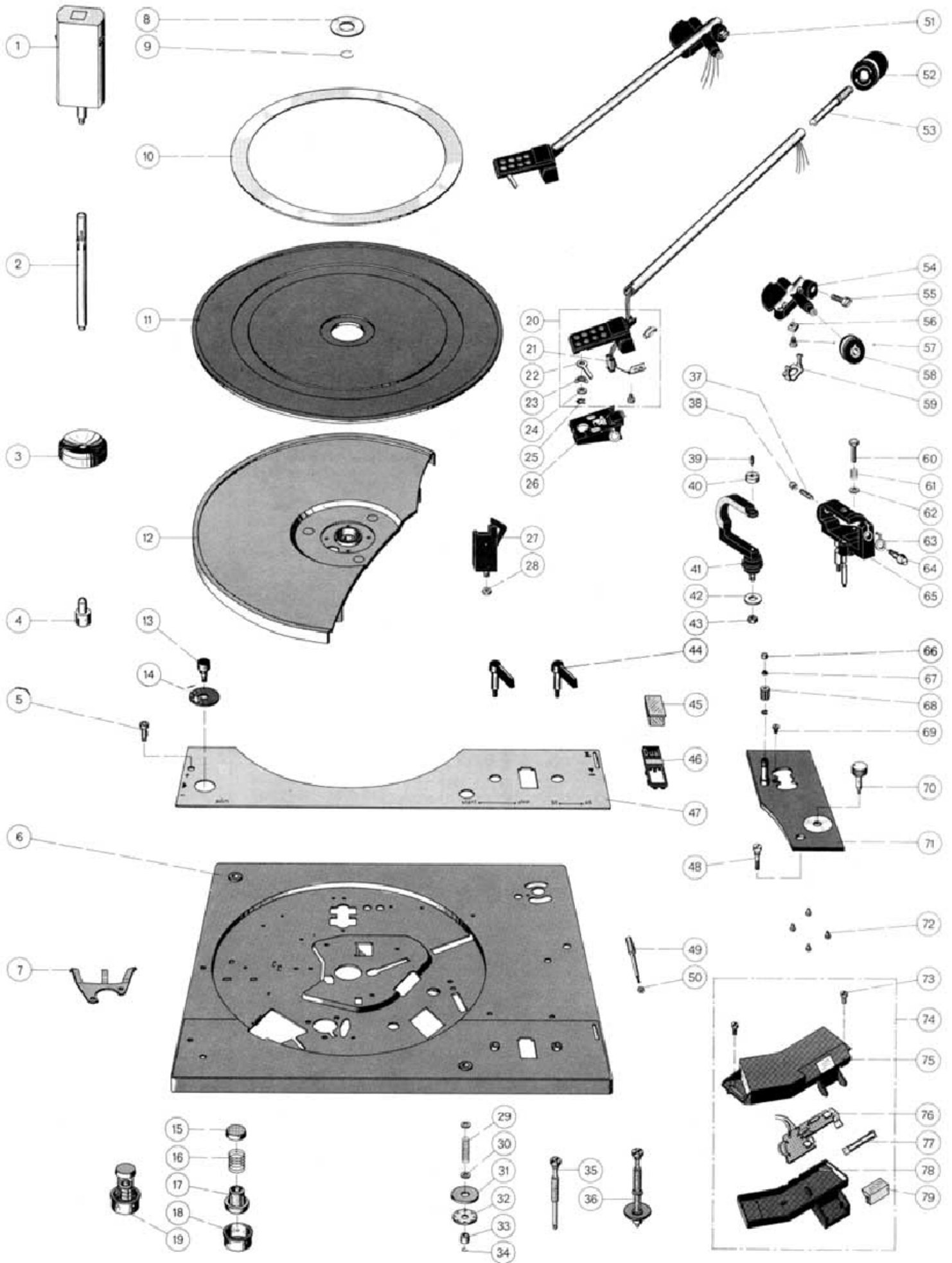
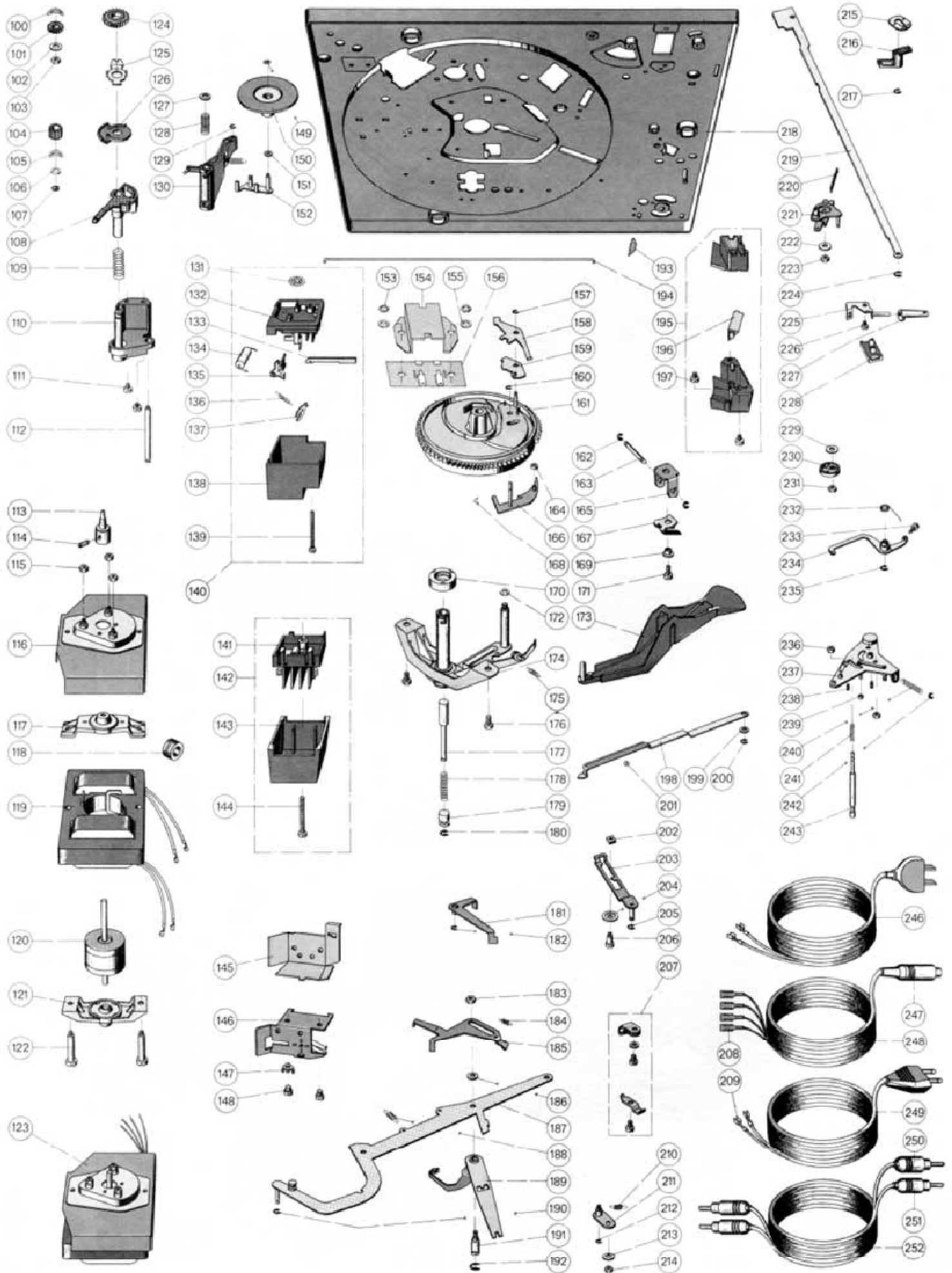

Fig. 29 Exploded view, parts below chassis



Pos.	Part.-No.	Description	Quantity
D 1	225 247	Silicon diode BY 183/300	1
C 1	225 322	Foil capacitor 68 nF/400 V/10 %	1
C 46	224 886	Foil capacitor 47 nF/250 V/20 %	1
R 1	232 402	Carbon resistor 22 kΩ/0.25 W/5 %	1
R 2	232 401	Carbon resistor 12 kΩ/0.25 W/5 %	1
77	225 321	Tubular glim lamp	1
78	233 230	Case lower part compl.	1
79	227 162	Prism	2
100	232 439	Spring washer 6.4/11/0.15	1
101	229 373	Adjuster wheel	1
102	210 586	Washer 3.2/7/0.5 St	1
103	210 362	Hexagon nut BM 3	5
104	228 112	Adjusting wheel	1
105	210 182	Lock washer, thr.	1
106	228 113	Washer 4.2/8/1.0 St	1
107	210 146	Lock washer 3.2	2
108	229 370	Selector segment	1
109	229 714	Compression spring	1
110	229 663	Bracket compl.	1
111	210 472	Fillister head cap screw AM 3 x 4	2
112	229 715	Bearing spindle	1
113	232 900	Motor pulley 50 Hz compl.	1
	232 901	Motor pulley 60 Hz compl.	1
114	230 559	Set screw M 2.5 x 3.5	1
115	210 366	Hexagon nut BM 4	3
116	229 027	Screen plate	1
117	233 038	Top bearing bracket complete	1
118	209 939	Cable grommet	1
119	233 086	Stator 110/220 V compl.	1
120	233 084	Rotor compl.	1
121	233 039	Bottom bearing bracket compl.	1
122	228 472	Centering screw	2
123	233 087	4-pole motor SM 400 110 - 220 V complete	1
124	229 374	Regulator wheel	1
125	229 695	Regulator plate	1
126	229 372	Adjustment washer	1
127	210 600	Washer 3.2/8/1 St	1
128	229 716	Compression spring	1
129	210 146	Lockwasher 3.2	2
130	229 672	Change lever	1
131	223 625	Lockwasher 3	1
132	233 012	Switch plate compl.	1
	233 013	Switch plate UL with special capacitor compl. ..	1
133	230 151	Slide	1
134	209 505	Capacitor 10 nF/1000 V/10 %	1
	230 355	Capacitor 68 nF/ 250 V/20 %	1
135	230 148	Switch slide	1
136	230 296	Tension spring	1
137	219 200	Snap spring	1
138	233 010	Cover normal compl.	1
	233 011	Cover UL compl. (for KS 4 with connection plate)	1
139	210 498	Fillister head cap screw M 3 x 28	1
140	233 009	Power switch compl.	1
	233 008	Power switch UL with special capacitor compl. ..	1
141	233 007	Connection plate compl.	1
142	233 005	Connection plate compl. with cover	1
143	233 006	Connection plate cover compl.	1
144	210 501	Fillister head cap screw M 3 x 35	1
145	229 748	Screen plate	1
146	232 987	Muting switch compl.	1
147	211 614	Soldering lug	1
148	210 469	Fillister head cap screw AM 3 x 3	2
149	200 633	Lock washer	1
150	217 888	Idler wheel compl.	1
151	229 719	Slip plate	1
152	229 747	Swinging arm compl.	1
153	210 362	Hexagon nut BM 3	5
154	233 089	Screen plate compl. with insulating plate	1
155	210 155	Serrated lockwasher A 3.2	2
156	227 254	Cynch socket plate	1
157	210 144	Lockwasher	1
158	229 635	Shut-off lever	1
159	229 756	Friction plate	1
160	210 145	Lockwasher 2.3	7
161	232 988	Main cam complete	1
162	210 145	Lock washer 2.3	7

Pos.	Part.-No.	Description	Quantity
163	200 528	Spindle	1
164	200 650	Rubber bush	1
165	229 648	Bearing support	1
166	229 755	Cam follower lever	1
167	229 642	Leaf spring	1
168	200 522	Snap spring	1
169	200 458	Spacer bush	1
170	229 754	Ball bearing	1
171	210 480	Fillister head cap screw AM 3 x 6	1
172	210 366	Hexagon nut BM 4	1
173	232 993	Main lever complete	1
174	232 990	Bearing bridge complete	1
175	227 045	Tension spring	1
176	218 155	Hexagon screw M 4 x 6	2
177	229 753	Change actuator stud complete	1
178	213 920	Compression spring	1
179	213 921	Bush	1
180	210 145	Lock washer 2.3	7
181	229 700	Switch slide	1
182	210 145	Lock washer 2.3	7
183	229 650	Extension nut	1
184	229 686	Tension spring	1
185	229 634	Start lever	1
186	210 586	Washer 3.2/7/0.5 St	2
187	229 674	Shift arm	1
188	229 698	Tension spring	1
189	229 757	Change lever complete	1
190	210 145	Lockwasher 2.3	7
191	229 654	Grooved pin	1
192	210 147	Lockwasher 4	1
193	200 687	Retainer spring	1
194	229 660	Control rod	1
195	233 232	Prism bridge compl.	1
196	227 162	Prism compl.	2
197	210 472	Machine screw AM 3 x 4	5
198	229 633	Shut-off slide	1
199	201 187	Slip plate	1
200	210 145	Lock washer 2.3	1
201	209 358	Ball 4	1
202	219 049	Square section	1
203	229 758	Paul complete	1
204	229 704	Washer 3.2/13/0.5 St	1
205	210 145	Lockwasher 2.3	7
206	227 060	Bolt	1
207	231 079	Cable clips complete	1
208	209 436	Flat connector	4
209	214 602	AMP connector	4
210	231 017	Tension spring	1
211	229 690	Start lever complete	1
212	210 145	Lockwasher 2.3	7
213	210 641	Washer 4.2/10/1 St	2
214	210 361	Hexagon nut M 3	3
215	223 146	Securing spring	1
216	229 362	Guide bearing	1
217	210 145	Lockwasher 2.3	7
218	233 245	Fitting plate complete	1
219	229 629	Positioning slide	1
220	229 649	Leaf spring	1
221	229 759	Adjuster lever	1
222	210 641	Washer 4.1/10/1 St	2
223	210 361	Hexagon nut M 3	3
224	210 145	Lockwasher 2.3	7
225	229 761	Bearing bracket	1
226	232 373	Fillister head cap screw AM 3 x 3	1
227	229 679	Lift cam	1
228	229 680	Brake section	1
229	216 867	Bowed lockwasher	1
230	220 899	Curve washer	1
231	210 361	Hexagon nut M 3	3
232	229 688	Torsion spring	1
233	221 260	Adjusting screw	1
234	229 796	Skating lever compl. with adjusting screw and torsion spring	1
235	210 146	Lockwasher 3.2	2
236	210 362	Hexagon nut BM 3	5
237	233 235	Segment compl.	1
238	229 772	Set screw M 2 x 4	2

Pos.	Part.-No.	Description	Quantity
239	223 777	Guide	1
240	218 591	Compression spring	1
241	216 853	Compression spring	1
242	201 184	Adjusting washer	1
243	229 769	Lifting bolt	1
246	232 995	Power cable America complete	1
247	209 424	Miniatur plug for audio cable	1
248	207 303	Audio cable compl. with miniature plug and socket for plat prong	1
249	232 996	Power cable Europa compl.	1
250	209 425	Cynch plug, white	2
251	209 426	Cynch plug, black	2
252	226 817	Audio cable compl. with RCA type plugs	1
**	228 114	Adjusting lever	1
**	229 987	Mounting instructions	1
**	230 747	Shipping carton compl.	1
**	230 914	Operating instructions 1228, 4 languages	
**	231 331	Operating instructions 1228 UAP	
**	214 120	Hardware for cartridge mounting	

** Not illustrated

Modifications reserved