

Dual

Edition May 1974

1225
Service

Dual 1224 Dual 1225 Service Manual

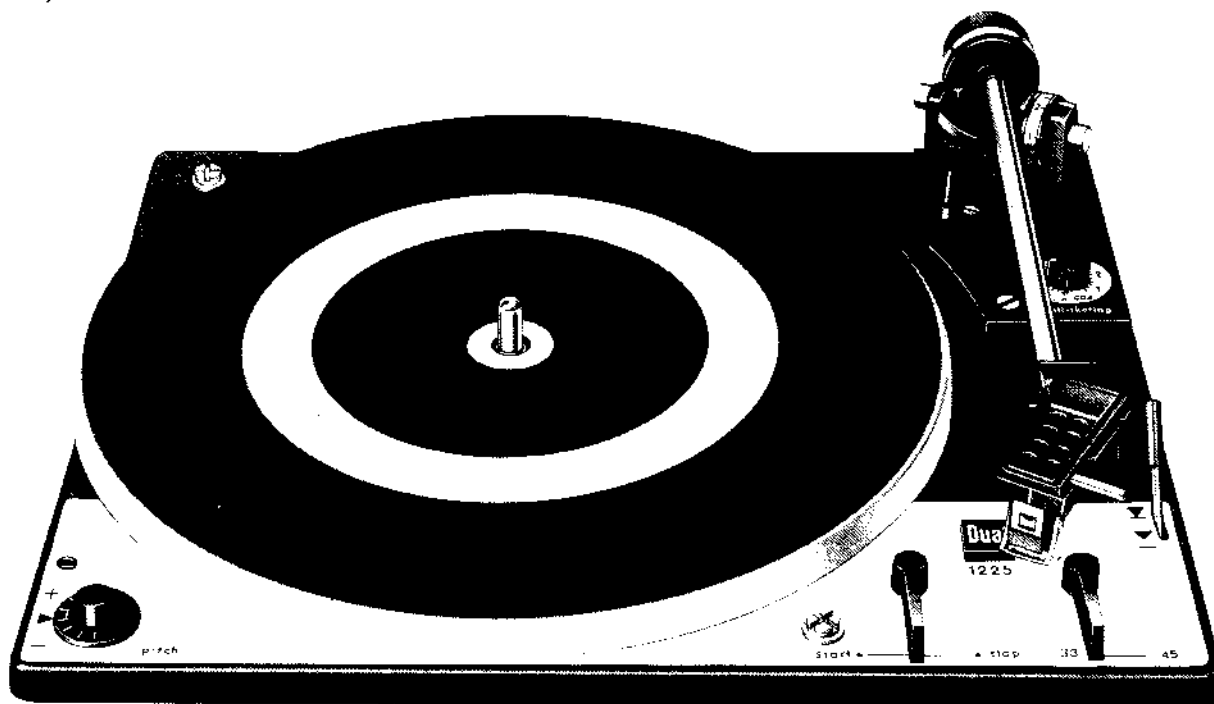

Technical data

Current type	AC 50 or 60 cycle, with appropriate motor pulleys	
Line voltage	110/130 V and 220/240 V selector	
Drive Dual 1224	Two-pole Dual single-phase asynchronous motor	
Drive Dual 1225	Four-pole asynchronous motor	
Power consumption	< 10 Watt	
Current requirements	approx. 60 mA at 220 V 50 cycle,	
Dual 1224	approx. 115 mA at 110 V 60 cycle	
Current requirements	approx. 64 mA at 220 V 50 cycle,	
Dual 1225	approx. 115 mA at 110 V 60 cycle	
Platter	1.45 kg, 270 mm ϕ	
Platter speeds	33 1/3 and 45 rpm, automatic tonearm setdown coupled to speed selector	
Pitch control	Adjustment of approx. 1 semi-tone (6 %) at both platter speeds	
Wow and flutter	< \pm 0.15 % rated in accordance with DIN 45 507	
Signal-to-noise ratio Dual 1224	Rumble signal-to-noise ratio > 55 dB Rumble unweighted signal-to-noise ratio > 35 dB	in accordance with DIN 45 500
Signal-to-noise ratio Dual 1225	Rumble signal-to-noise ratio > 56 dB Rumble unweighted signal-to-noise ratio > 37 dB	in accordance with DIN 45 500
Tonearm	Torsionally-rigid tubular aluminium arm with vertical pivot mounting, horizontal self-adjusting pivot mounting	
Pick-up head (cartridge holder)	Removable, suitable for acceptance of all (Dual 1224 all piezo electric) cartridges having 1/2" mounting and a deadweight of 2 – 10 grams (including mounting fixtures)	
Stylus pressure	Continuously-adjustable from 0 – 8 p, reliable as from 1 p stylus pressure	
Pick-up cartridge	See separate data sheet	
Dimensions	329 x 274 mm (+ 2 mm tonearm overhang)	
Weight Dual 1224	3.9 kg	
Weight Dual 1225	4 kg	

Dual Gebrüder Steldinger · 7742 St. Georgen/Schwarzwald

Fig. 1 Pick-up Connection Diagram

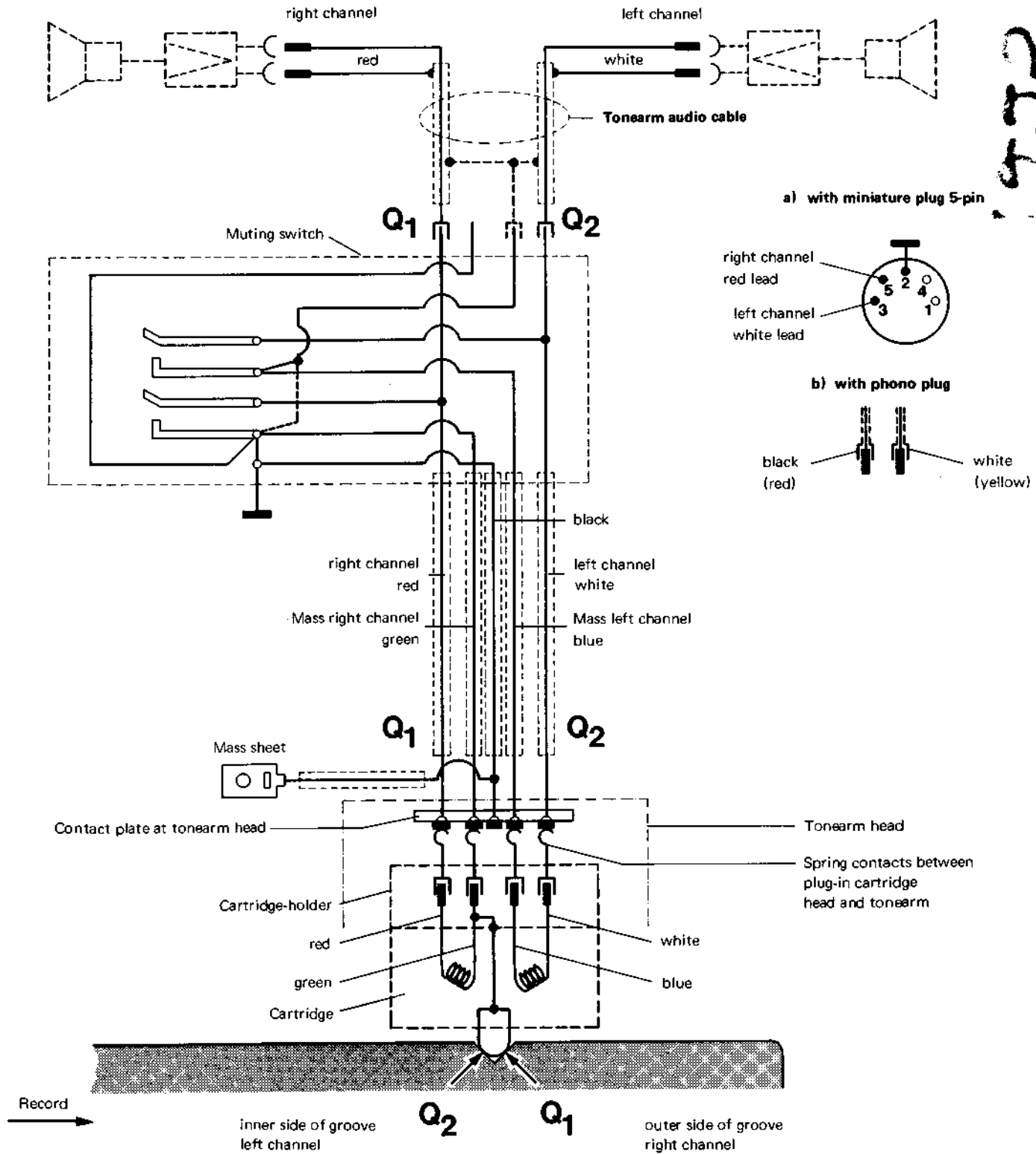

Contents

	Page
Technical Data	1
Pick-up Connection Diagram	2
Motor and Drive	4
Pitch Control	5
Platter does not run when unit is plugged in and start switch operated	5
Platter does not reach required speed	5
Rumble in reproduction	5
Correct nominal speed obtained only at extreme settings of pitch control	5
Tonearm and Suspension	6
Replacing the Complete Tonearm and Bearing Assembly	6
Replacement of Tonearm	6
Tonearm Anti-skating Device	7
Pick-up head not parallel to platter	7
Tonearm Guide Mechanism	8
Tonearm lift	8
Tonearm misses edge of record	9
Tonearm strikes record during change cycle	9
Tonearm does not move onto record when drop cycle is started	9
Tonearm lowers too quickly when drop cycle is started	9
Tonearm returns to rest immediately after being placed on record manually	9
Start Cycle	9
Manual Start	10
Stop Switching	10
Muting Switch	11
Record Drop	11
Shut-off and Change Cycle	11
Shut-off Mechanism	12
Platter stops after automatic set-down of tonearm	12
The last record of a stack keeps repeating	12
After adjusting the tonearm set-down point for 7" records the set-down point is not correct for 12" records	13
Record drops when unit is switched to "stop"	13
Records do not drop	13
Stylus slips out of playing groove	14
Vertical tonearm movement restricted during set-down	14
Disturbing noises during change operation	14
No sound	14
Motor does not shut off	14
Acoustic feedback	14
Spare Parts with Exploded Views	15 - 20
Lubrication	21

Fig. 2 Motor suspension and platter drive Dual 1224

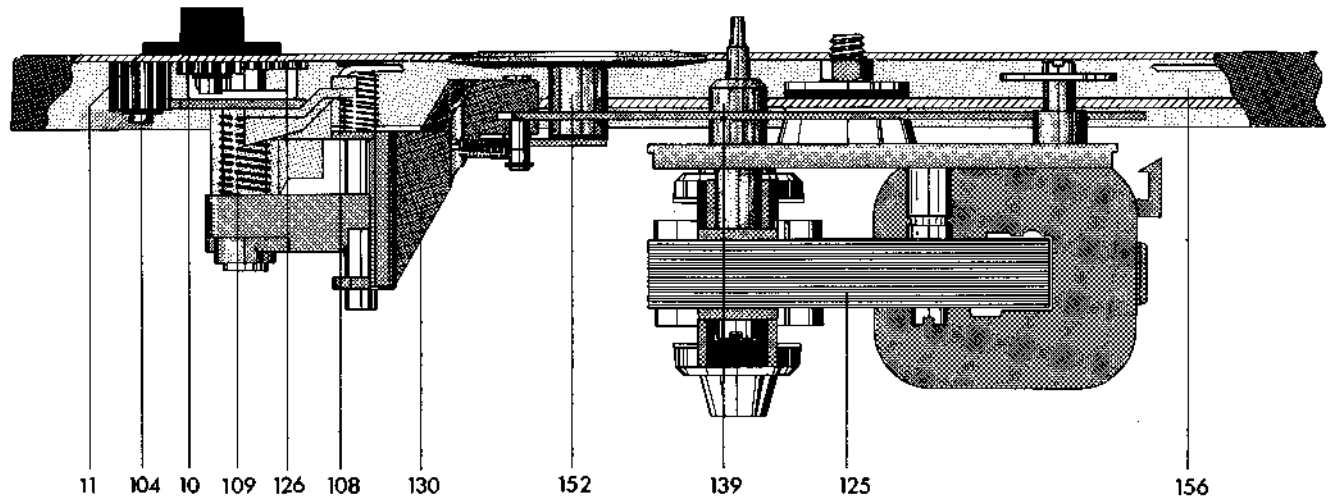
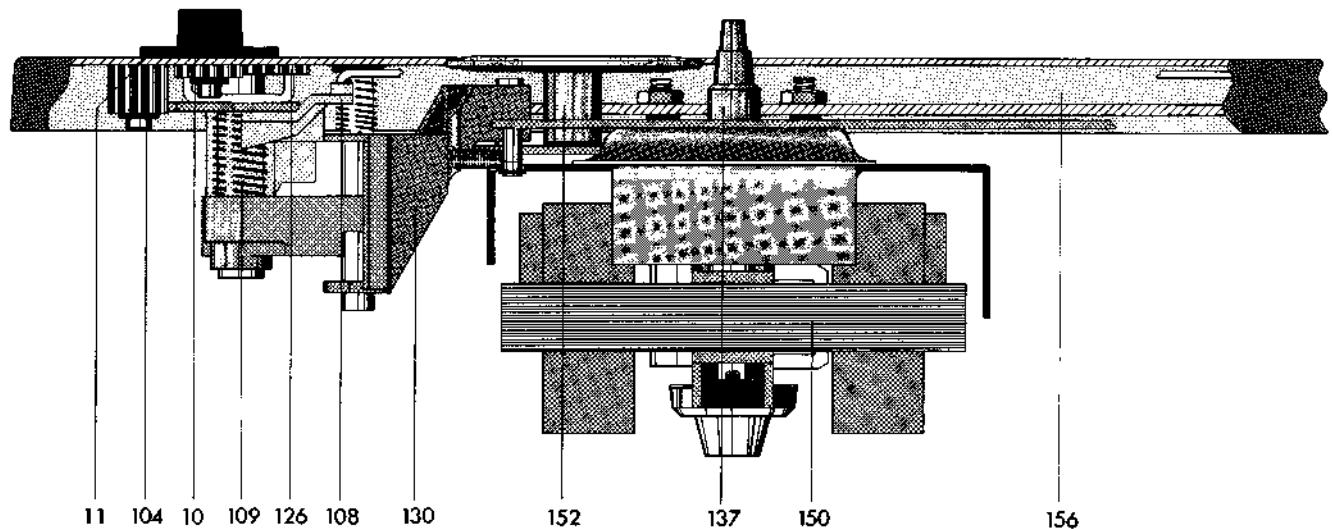

Fig. 3 Motor suspension and platter drive Dual 1225



Motor and Drive

The platter and associated mechanism are driven on the Dual 1224 by a two-pole asynchronous motor (125) and on the Dual 1225 by a four-pole asynchronous motor (150). Both motors have a rotor balanced at two levels, polished bearing surfaces and ensure vibrationfree running. In addition, the four-pole motor is distinguished by an extremely small stray magnetic field. The speed of the motors is constant over a supply voltage range of $\pm 10\%$. Deviations in speed depend on, and are proportional to, the line frequency. Adaptation of the motor to 50 or 60 Hz power is accomplished by changing the motor pulley (137/139).

Two-pole motor (Dual 1224):
 Pulley for 50 Hz Art. No. 232 896
 Pulley for 60 Hz Art. No. 232 897

Four-pole motor (Dual 1225):
 Pulley for 50 Hz Art. No. 232 898
 Pulley for 60 Hz Art. No. 232 899

The motor pulley is secured to the motor shaft by a setscrew. When a pulley is replaced or exchanged it must be set at the correct height (see Fig. 4).

The platter is driven by the idler wheel (152) which is automatically disengaged from the motor pulley when the unit is shut off in order to protect its driving surface.

Platter speeds of $33 \frac{1}{3}$ and 45 rpm are selected by raising or lowering the idler wheel (152) to the appropriate step on the motor pulley.

When the selector lever (33) is moved, the selector segment (108) rotates. This causes the lever (130) fitted in the slot of the selector segment to move in a vertical direction. The idler wheel (152) mounted on the swinging arm (155) is lifted off the motor pulley and set down again on the motor pulley step for the appropriate speed.

Pitch Control

For platter speeds of 33 1/3 and 45 rpm the unit incorporates a power-independent pitch control which permits a platter speed variation of up to 6% (approximately one semi-tone).

When the pitch control knob (10) is turned, the switch segment (108) and the switch lever (130) attached to it are moved up or down. This vertical displacement changes the position of the idler wheel on whatever step of the motor pulley it has been placed, by the speed selector, and due to the tapered shape of the pulley effects approximately $\pm 3\%$ variation in speed.

Fig. 4 Position of idler wheel

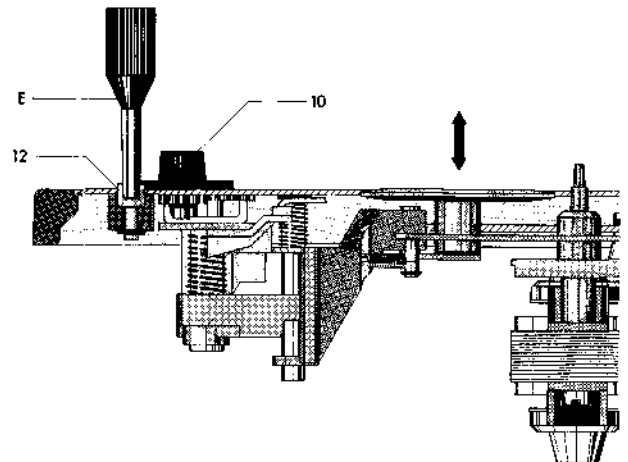

Trouble	Cause
Platter does not run when unit is plugged in and start switch operated	a) Current path to motor interrupted b) Idler wheel (152) not in contact with platter c) Motor pulley loose
Platter does not reach required speed	a) Motor pulley is not correct for local line frequency b) Slip between idler wheel (152) and motor pulley or platter c) Excessive friction in motor, idler wheel or platter bearings
Rumble in reproduction	Worn idler wheel
Correct nominal speed obtained only at extreme settings of pitch control	Idler wheel does not contact motor pulley correctly

Remedy

- Check connection at switch plate and voltage selector
- Check switch lever assembly (130)
- Tighten motor pulley
- Change motor pulley
- Clean friction surfaces of idler wheel, motor pulley and turntable platter. If necessary, replace idler wheel. Once the drive surface of the platter has been cleaned do not touch it with your fingers
- Clean and oil bearings

Replace idler wheel (152), clean platter drive surface and motor pulley with greaseless solvent. (Once surfaces are cleaned do not touch them with your fingers).

Adjust position of idler wheel by turning adjustment screw (12) so that the fine speed adjustment knob (10) is in the center position by correct nominal (Fig. 4).

Fig. 5 Motor field connections (less voltage selector)

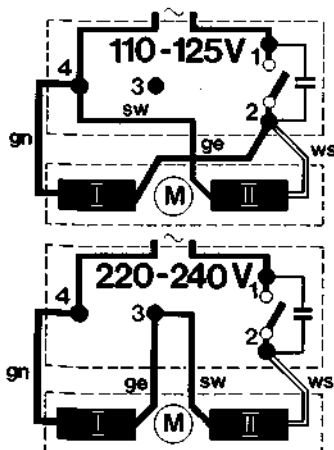

Coil II not in 2-pole motor which, according to model, can only be used for 220 V or 110 V or 150 V

Fig. 6 Motor field connections (with voltage selector)

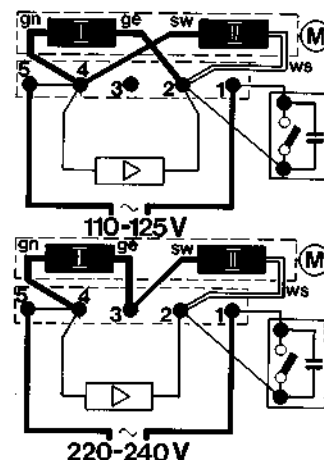

Tonearm and Tonearm Suspension

The tonearm of the Dual 1224 and 1225 is counter balanced and pivot mounted vertically and horizontally. This provides extremely favourable tracking characteristics. The tonearm head is removable. To aid in replacing or adjusting the tonearm head a hole is provided in the chassis to facilitate adjustment of the tonearm head without first removing the tonearm. Before setting the correct stylus force for the cartridge which has been installed the tonearm should be balanced with the stylus force setting at zero. It is recommended that balancing should be carried out in the direct vicinity of the tonearm rest. This is carried out by rotating the counterweight.

The counterweight is designed so that it can balance cartridges weighing 1 - 10 g.

For shock absorption (absorption of brief shocks) the counterweight is flexibly mounted on the tonearm and secured to prevent unintentional rotation. The tonearm head is designed to accept all cartridges with internationally standard 1/2" mounting centers and weighing not more than 10 g. Stylus force is set by rotating the graduated spring housing (58) and thus tensioning or slackening the coil spring contained therein. The scale is calibrated for an adjustment range of 0 - 5 p, permitting accurate setting within that range in 0.5 p steps.

Fig. 7 Tonearm bearing assembly

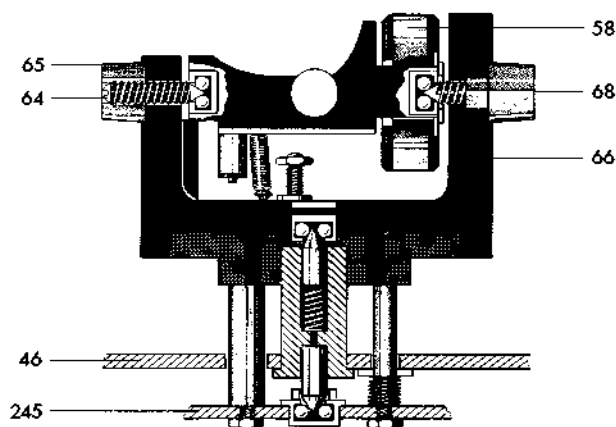
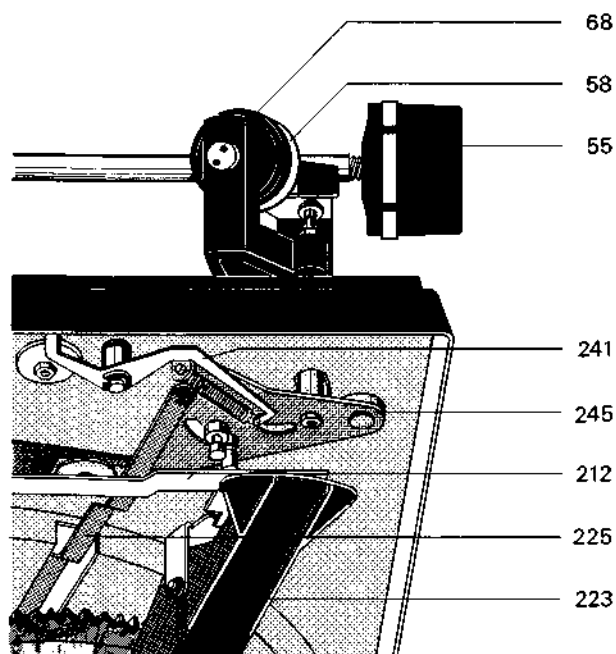

Fig. 8 Tonearm bearing assembly (view from underneath)



Replacing the Complete Tonearm and Bearing Assembly

To replace the complete tonearm and bearing assembly we recommend proceeding as follows:

1. Tighten unit in repair jig, set stylus force scale to zero and lock the tonearm in position
2. Turn unit upside down, remove retainer spring (188) and unsolder tonearm leads
3. Remove main lever (223), disengage spring (256)
4. Remove lock washer (227) and skating disc (226), remove shut-off slide (225) from eccentric pin on segment, ensure ball (224) does not drop out
5. Slacken hexagon nuts (244), remove segment (245), then remove tonearm, ensuring that bearing pivot (39) and compression spring (40) do not drop out.

Tonearm complete with bearing frame assembly should be refitted in reverse order. The unit is in normal position. Insert tonearm complete with bearing frame assembly and lock in rest. With tonearm held in place turn unit upside down. Place segment (245) in position and fit hexagon nuts.

Replacement of Tonearm

To remove the tonearm from the bearing frame unsolder the tonearm leads and set the tonearm tracking force scale to zero. Unscrew locknut (65) with setscrew (64) and bearing screw (68) (left-hand thread). Carefully remove tonearm from bearing frame.

Tonearm Anti-skating Device

The geometrically caused skating force acting on any tonearm is eliminated to a large extent in the case of the Dual 1224 and 1225 by means of a precision antiskating device.

The skating force is dependent on the tonearm geometry, on the stylus force and the tip radius of the cartridge stylus. The inward pull of the tonearm caused by the skating effect leads not only to undesirable jumping of the tonearm when set down on the record but also unequal forces on the two opposite groove walls with resultant unfavourable effects. These can be corrected with the aid of a suitable anti-skating device. By turning the knob (69) of the anti-skating device located on the cover the asymmetrical plate cam (238) is moved. This plate cam has two different curvatures which, according to the different scales used, for spherical and elliptical tip styli and for CD 4 pick-up cartridges, move the skating lever (241) out of its position of rest and transmit the counter force to the tonearm by means of the tension spring (256).

Skating adjustment is set at the works for conical styli with a tip radius of $15 \pm 2 \mu\text{m}$ and for elliptical styli with measurements of $5/6$ and $18/22 \mu\text{m}$ and also for CD 4 cartridges. The hexagon nut (239) is firmly tightened and locked with paint. Readjustment should only be attempted with the aid of the Dual Skate-0-Meter and the L 096 test record. This is best done by an authorised Dual service station.

Fig. 9 Anti-skating force

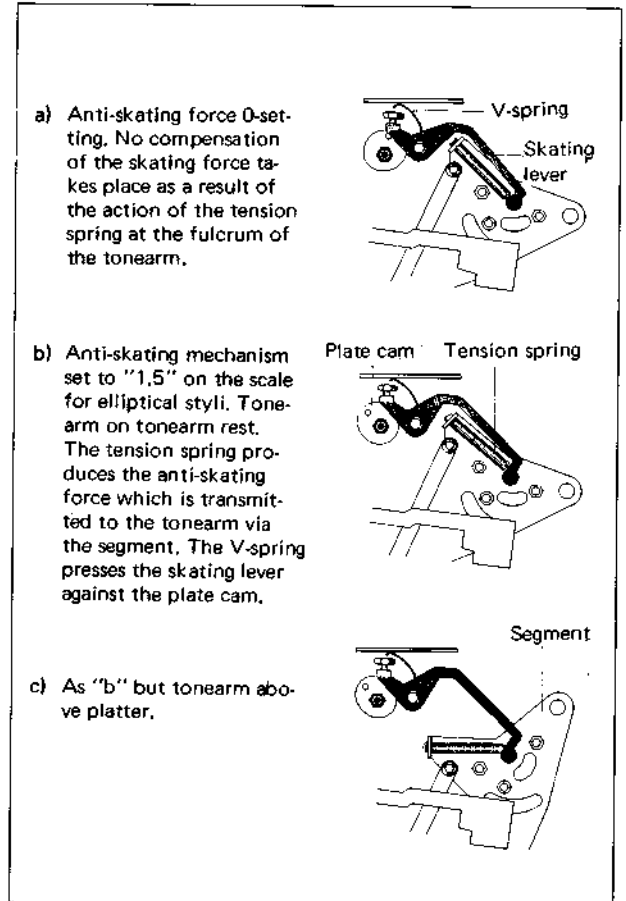
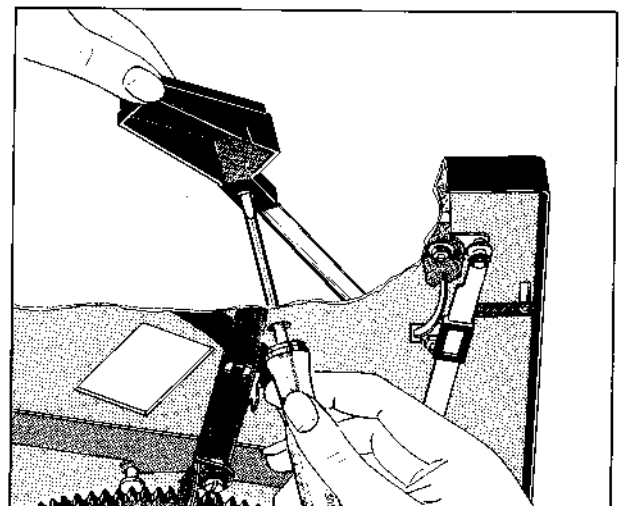

Fig. 10



Trouble

Tonearm head not located parallel to platter

Cause

Shocks incurred during transport have altered the location of the tonearm head on the tonearm tube

Remedy

Remove platter, slacken the screw on the tonearm head with the aid of a screwdriver inserted through the hole in the chassis provided for this purpose. Retighten screw after aligning the tonearm head (Fig. 10).

Fig. 11 Tonearm guide mechanism

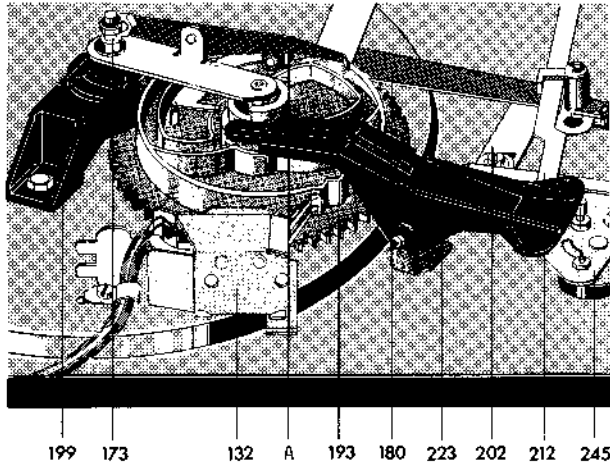

Tonearm Guide Mechanism

A guide groove located on the underside of the main cam (193) controls the automatic lift and set-down of the tonearm as the cam rotates through 360°. Tonearm lift and lowering are controlled by main lever (223) and lift screw (249). Horizontal movements are controlled by the main lever (223) and the segment (240).

Automatic tonearm set-down is designed for 12" and 7" records and is coupled to the platter speed selector. Set-down points are determined by the spring pin of segment (240) contacting the positioning slide (212) which is only raised by the main lever (223) during the change cycle and thus moves within reach of the spring pin fitted on the segment. On completion of set-down or change cycle (tonearm sets down on the record) the positioning slide (212) is released again and returns to its normal position. It thus moves out of reach of the spring pin permitting the tonearm to move horizontally without hindrance while playing the record.

Tonearm Lift (Cue Control)

The tonearm lift permits the tonearm to be set down on the record safely at any desired point outside the shut-off area.

Moving the tonearm lift handle (44) forward causes lift cam (235) to rotate. This movement is transmitted via positioning slide (212) to the lift pin which then raises the tonearm.

After moving the tonearm (by hand) to the desired spot on the record the tonearm lift handle is tapped lightly (to the rear) to release the mechanism.

The positioning slide (212) is thus released and the tonearm descends slowly, controlled by the viscosity damped lift pin.

The height of the stylus above the record can be varied from zero to 6 mm by turning adjuster screw (43). Turning to the right increases the height, turning to the left reduces the height.

Fig. 12 Tonearm lift (tonearm raised)

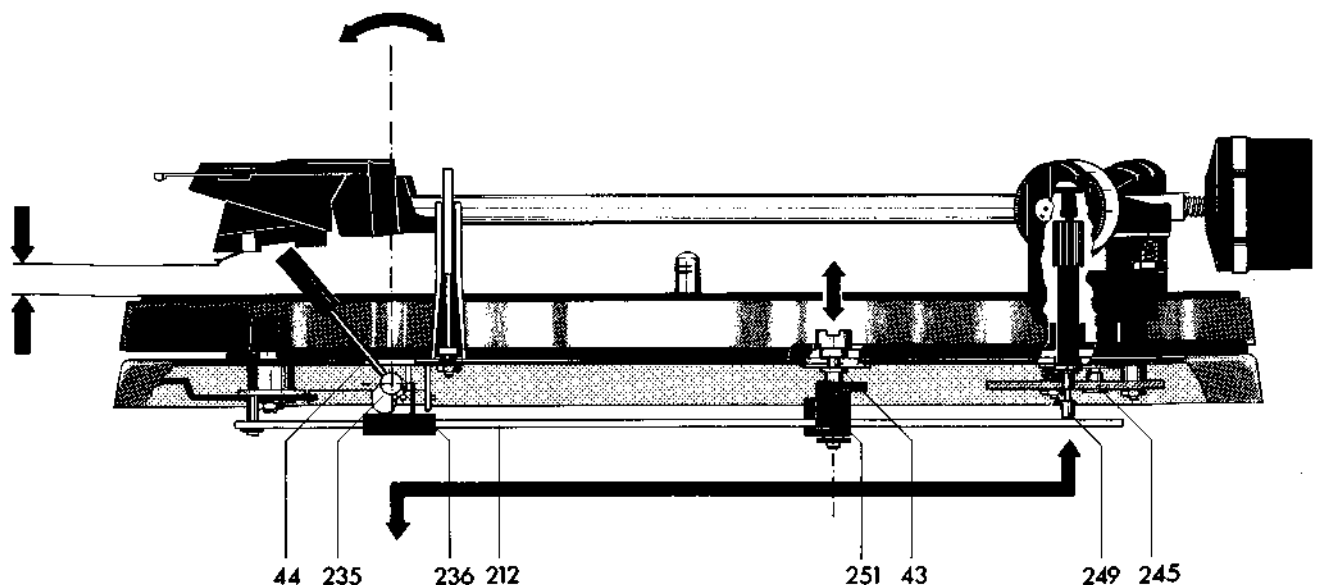

Trouble

Tonearm misses edge of record

Cause

- a) Record setting incorrect
- b) Set-down point incorrectly adjusted
- c) Record not standard size
- d) Friction surfaces of tonearm clutch dirty

Tonearm strikes record during change cycle

Tonearm height adjustment incorrectly set

Tonearm does not move onto record when drop cycle is started

Excessive damping caused by dirt in silicone oil in lift tube

Tonearm lowers too quickly when drop cycle is started

Insufficient damping caused by improper addition of lubricant to damping compound

Tonearm returns to rest immediately after being placed on record manually

Shut-off mechanism has shifted out of position during shipping

Remedy

- a) Carry out necessary adjustment by means of right-hand selector lever (33).
- b) Set right-hand selector lever to "45". With a screwdriver inserted through the hole exposed turn eccentric pin until the tonearm sets down approximately 1.5 mm from the edge of the record. (Adjustment is only carried out for 7" records and is then automatically correct for 12" records.)
- c) Use standard record
- d) Clean clutch surfaces

Adjust arm height with adjuster sleeve (38). Height is correct when stylus tip is 2 - 3 mm above selector lever (33) when arm is removed from rest.

Remove tonearm complete with bearing assembly (described on page 6). Remove lock washer (37), detach adjuster sleeve and remove second lock washer (37). Remove lock washer (253) on adjuster lever (214). Detach positioning slide from pin on adjuster lever, turn slightly until lift pin (249) is released. Remove lift pin. Clean lift tube and lift pin. Smear lift pin evenly with "Wacker silicone oil AK 500 000". Smear lift pin evenly with "Wacker silicone oil AK 500 000". Reassemble components.

Remove tonearm complete with bearing assembly (described on page 6). Remove lock washer (37), detach adjuster sleeve and remove second lock washer (37). Remove lock washer (253) on adjuster lever (214). Detach positioning slide from pin on adjuster lever, turn slightly until lift pin (249) is released. Remove lift pin. Clean lift tube and lift pin. Smear lift pin evenly with "Wacker silicone oil AK 500 000". Reassemble components.

Before using changer after moving, run it through start cycle with tonearm locked on rest (selector moved to "start")

Start Cycle

Moving the start switch (33) causes change lever (209) to rotate outwards. This initiates the following functions:

- a) A lug rotates shift arm (180). The latter in turn by means of a tension spring moves the change lever (130) and thus the idler wheel (152) into engagement with motor pulley (137/139) and platter (9). At the same time the power switch (167) is actuated by the switch slide (177) coupled to the shift arm and the platter starts to rotate.
- b) Change lever (209) is brought within reach of the cam follower lever (195) so that the latter is pushed into the change position after subsequent rotation of the main cam.

Fig. 13 Start position

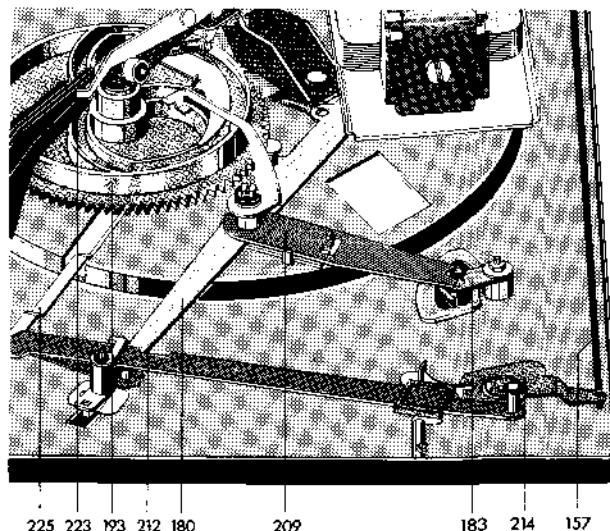
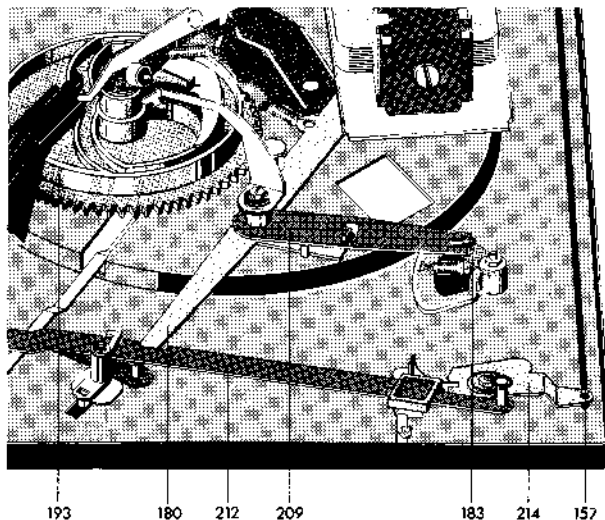

Fig. 14 Stop position



Moving the operating switch (33) also releases the start level (208) which is pulled towards the main cam by means of tension spring (207). By this means the shut-off lever (190) is moved within the range of the dog on the platter pinion thus driving the main cam. The change lever (209) is also locked. To prevent malfunctions the operating switch is locked in position during the start cycle (rotation of the main cam). Just before the main cam reaches neutral position (at the end of the change cycle) the start lever is pushed clear by the main cam and thus the operating switch and change lever are returned to their original positions. After installation and after moving the changer the unit should be started with the tonearm locked on the rest. This will automatically readjust the shut-off lever which may have shifted out of position.

Manual Start

When the tonearm is swung inwards by hand the pawl (202) on the shift arm (180) engages on a square end pin fitted in the chassis, retaining the shift arm in this position and thus the idler wheel (152) in engagement with the platter. The slide (177) linked to the shift arm actuates the power switch and sets the platter in motion.

On reaching the run-out groove the tonearm automatically returns to its rest position and the unit shuts itself off. If, however, the tonearm is lifted off the record before completion of play and returned to the rest, the pin of segment (245) releases the pawl (202). The tension spring then returns the shift arm to its initial position, opening the power switch and disengaging the idler wheel.

Fig. 15 Muting Switch

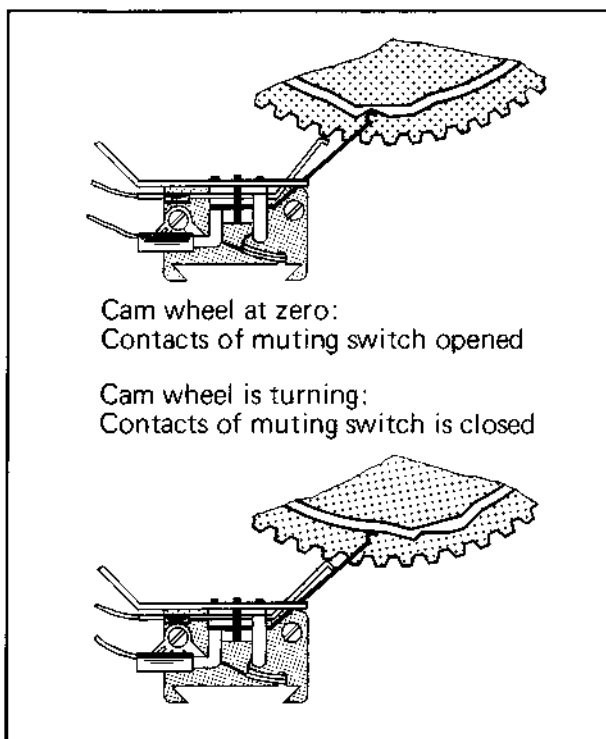

Stop Switching

When the operating lever is moved to "stop" only the starting lever (208) is drawn forward. As a result, the shut-off linkage engages with the main cam. The cam follower lever remains in stop position. When the tonearm is on its rest and the operating lever is pushed to "stop", the change lever must not jam.

Muting Switch

To prevent disturbing noise during the change cycle and during automatic operation of the tonearm the unit is fitted with a muting switch. Control of the switch springs for both channels is effected by the main cam. With the unit in position of rest the muting switch is opened.

Fig. 16 Record Drop

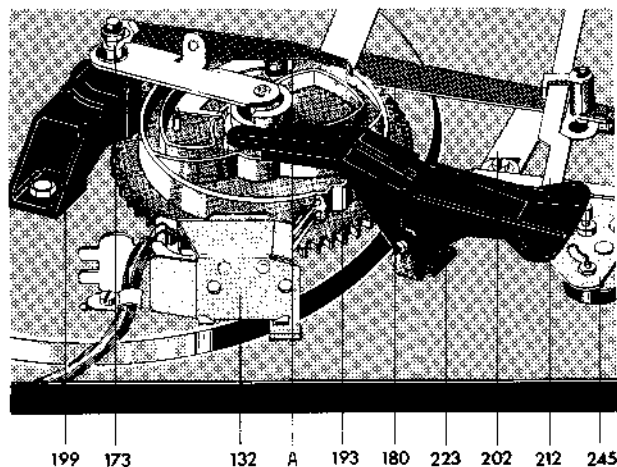

Record Drop

Insert the appropriate spindle - AU 3 for standard records (7 mm center hole) or AS 12 for 45 rpm records (38 mm center hole).

Record drop is initiated by rotation of the main cam (193) whose cam surface guides the cam rocker (A) and the change actuator stud (173). The resultant downward movement initiates record drop via the changing spindle or automatic spindle.

The record drop cam is located on the main cam so that record drop can only take place when the tonearm is over the tonearm rest, that is to say, out of reach of the largest possible records (12" diameter).

Fig. 17 Actuating "change" or "shut-off"

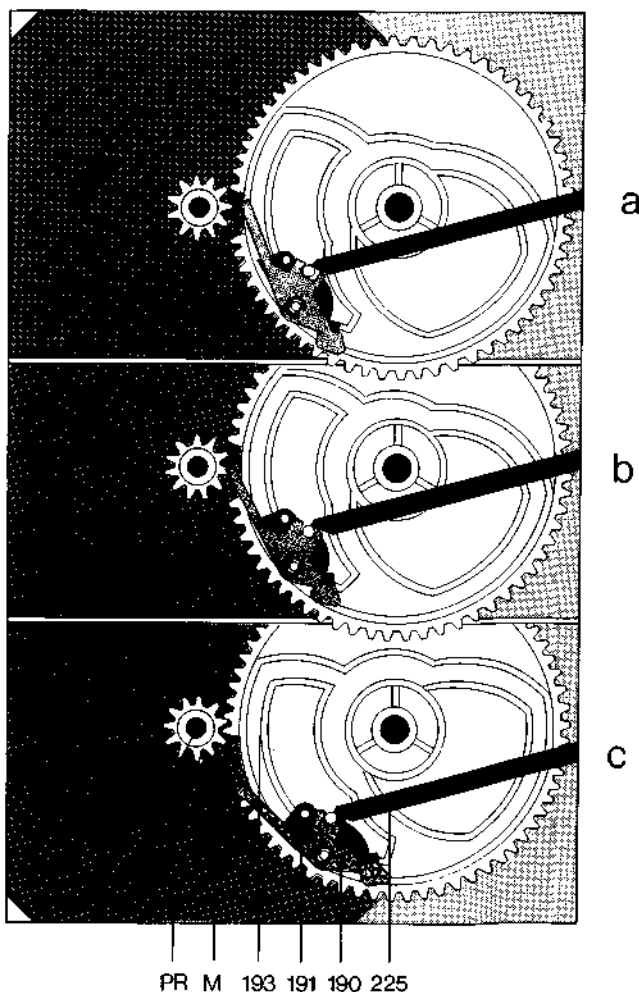

Shut-off and Change Cycle

The dog (M) of platter pinion (PR) and shut-off lever (190) actuate both the change cycle at the end of the record and shut-off after the last record in a stack is played.

At the end of a record the tonearm moves towards the center at an accelerated rate due to the increased pitch of the grooves. This motion carries shut-off lever (190) towards the dog by means of shut-off slide (225). The eccentric dog pushes the shut-off lever (190) back at each revolution as long as the tonearm advance is only one normal record groove. (Fig. 17 a)

The run-out groove with its steeper pitch moves the shut-off lever (190) against the dog with greater force so that the shut-off lever is picked up and moves with it. (Fig. 17 b)

The main cam (193) is thus moved out of its neutral position into engagement with the pinion of the platter. (Fig. 17 c)

Fig. 18 Change Cycle

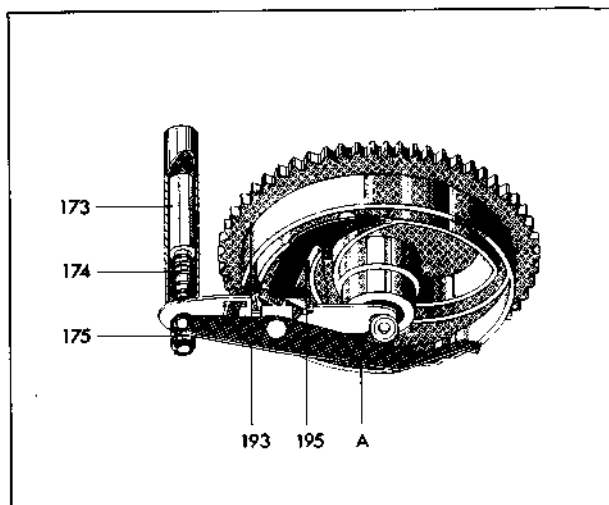

Shut-off Mechanism

The shut-off and change functions are determined by the position of the cam follower lever (195). After every start or record drop the cam follower lever (195) is moved to stop position by main lever (223) (longer end of the cam follower lever towards the center of the main cam). As the record is dropped the cam follower lever (195) is turned to start position by cam rocker (A) so that the tonearm can swing in after record drop and be lowered onto it. If there are no more records on the spindle its downward movement is locked and the cam rocker cannot turn the cam follower lever, the lever remains in stop position and causes the tonearm to lower onto its rest. When main cam (193) returns to neutral position the lug of shift arm (180) is able to move into the recess provided in the main cam, actuate power switch (167) and disengage idler wheel (152).

Fig. 19

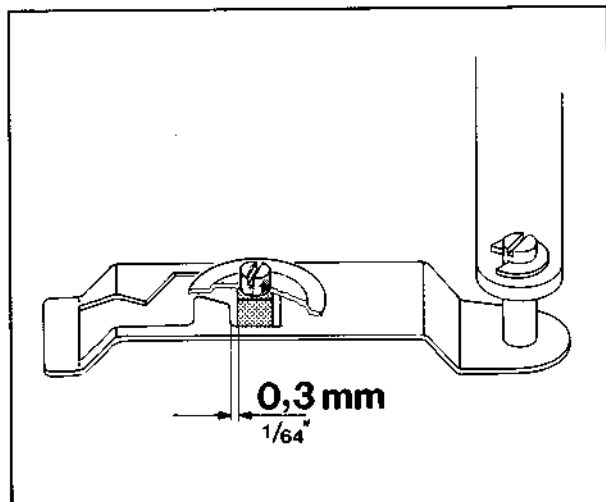

Trouble

Platter stops after automatic set-down of tonearm

Cause

- a) Shift arm (180) not locked by pawl (202).
- b) Power switch has interrupted power supply (has switched off)

Remedy

- a) By turning the eccentric pin on the pawl
- b) By adjusting switch slide (177) maximum play between switch slide and shift arm (0.3 mm).

Fig. 20

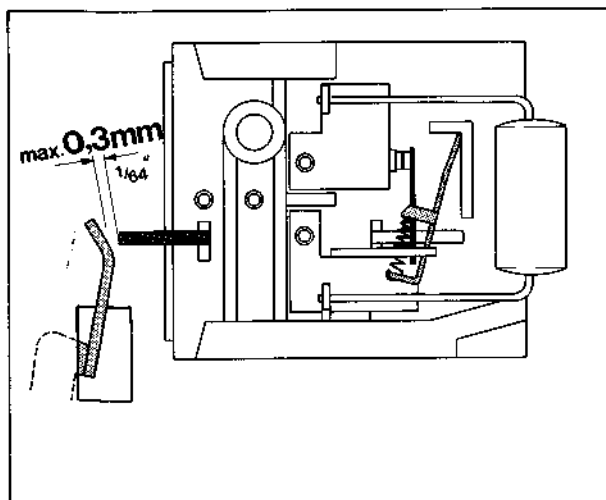

Trouble

The last record of a stack keeps repeating

Cause

Defective spindle

Remedy

Replace spindle

Trouble

After adjustment of the tonearm set-down point for 7" records the set-down point for 12" records is incorrect

Cause

Eccentric pin (E) of adjuster lever (214) out of adjustment

Remedy

Adjust tonearm set-down by turning eccentric pin (E)

Fig. 21

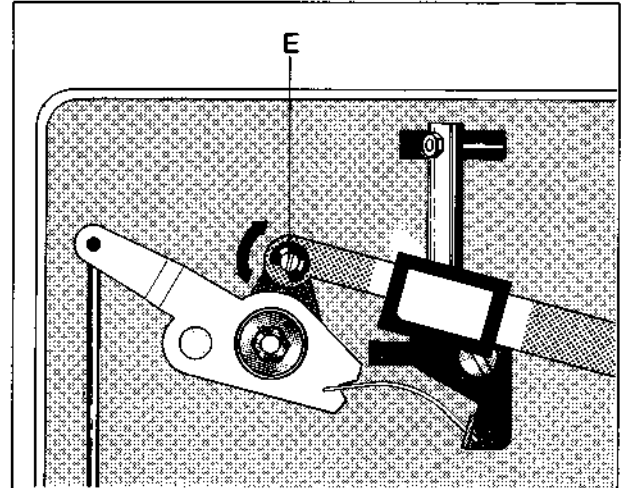

Trouble

Record drops when unit is switched to "stop"

Cause

Cam rocker (A) not locked by change lever

Remedy

Adjust change lever so that it passes approximately 1.5 mm underneath the cam rocker when "stop" function is initiated

Fig. 22

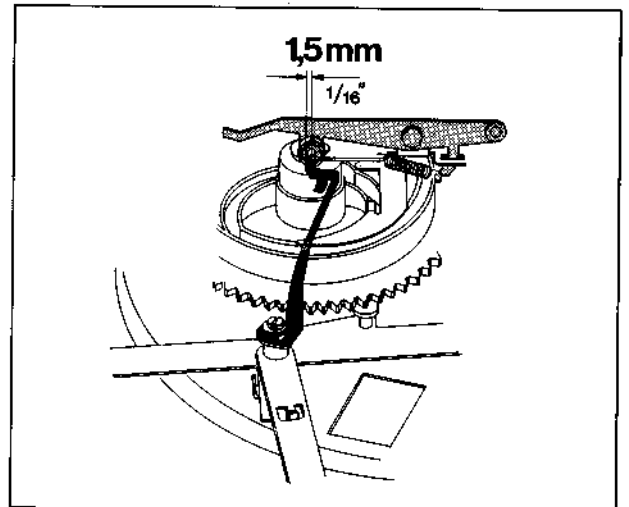

Trouble

Records do not drop

Cause

Cam rocker has insufficient travel

Remedy

Adjust travel with eccentric screw on cam rocker. Adjustment is correct when, with the main cam in neutral position and the changing spindle locked, the three supports of the changing spindle describe longitudinal movement of 0.2 mm when the change actuator stud is pushed up

Fig. 23

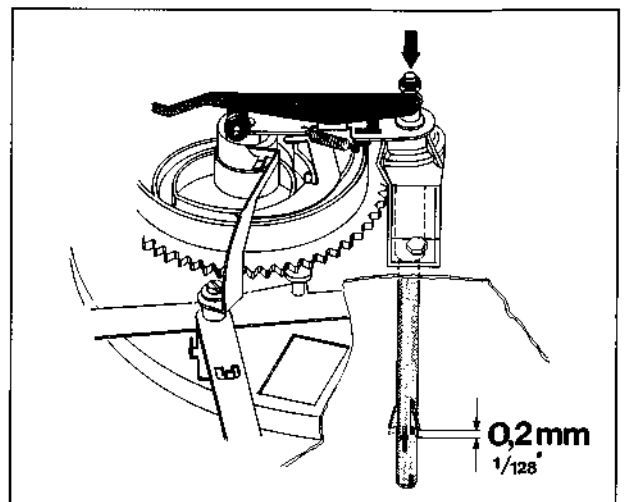

Trouble	Cause	Remedy
Stylus slips out of playing groove	<ul style="list-style-type: none"> a) Tonearm not balanced b) Tonearm contact pressure insufficient c) Stylus point worn or splintered d) Excessive bearing friction in tonearm bearing e) Steel ball (224) of shut-off slide missing f) Antiskating adjustment incorrect 	<ul style="list-style-type: none"> a) Balance tonearm b) Check tonearm balance, set contact pressure to value stated by cartridge manufacturer c) Renew stylus d) Check tonearm bearing e) Renew steel ball (224) f) Correct anti-skating adjustment
Vertical tonearm movement restricted during set-down cycle	<ul style="list-style-type: none"> a) Excessive bearing friction b) Lift pin sticks in lift tube 	<ul style="list-style-type: none"> a) Eliminate friction by adjustment of bearing screw (setscrew 64) and check balance b) Remove lift pin and clean (described on page 9)
Tonearm moves with stylus pressure and anti-skating scale in zero position a) outwards, b) inwards	<ul style="list-style-type: none"> a) Anti-skating device out of adjustment b) Excessively taut tonearm leads producing torque 	<ul style="list-style-type: none"> a) Adjust skating lever so that skating spring acts correctly at tonearm pivot b) Slacken tonearm leads
During change, start and stop operations, noise from the mechanism can be heard in speaker system	Muting switch maladjusted. Clearance between contact strips on muting switch excessive	By bending contact strips. Adjustment is correct when, with the main cam in neutral position, the gap between the wipers and the contact strips on the muting switch is approximately 0.5 mm. Spray contact springs with preservative (e.g. Kontakt 61) and check adjustment of contact strips
No sound. The short circuit of the pick-up leads is no longer broken	Clearance between wipers and contact strips absent or insufficient	By adjusting contact strips. Adjustment is correct when, with the main cam in neutral position, the gap between the wipers and the contact strips on the muting switch is approximately 0.5 mm
Motor will not shut off when tonearm is on arm rest	Suppression capacitor (in power switch) is defective (short circuit)	Renew suppression capacitor in power switch
Acoustic feedback	<ul style="list-style-type: none"> a) Chassis parts (e.g. connection leads) are touching base cutout. b) Connecting leads are too taut 	<ul style="list-style-type: none"> a) Correct cutout according to instructions supplied with unit. Move leads b) Slacken or extend leads

Replacement parts

Pos.	Part-No.	Description	Quantity
1	215 470	Automatic spindle AS 12	1
2	213 895	Automatic spindle AW 3	1
3	220 213	Centring piece	1
4	200 709	Plate pin	1
5	214 054	Washer	1
6	200 543	Retaining ring	1
7	229 732	Ring	1
8	232 970	Turntable mat compl. with ring and washer	1
9	232 971	Turntable compl. with mat	1
10	229 743	Knob	1
11	229 733	Scale ring	1
12	228 111	Adjusting screw	1
13	230 529	Threaded piece	1
14	230 521	Compression spring blue (1224)	3
	230 523	Compression spring (1225)	1
15	200 723	Rubber damping block	3
16	200 722	Steel cup	3
17	232 972	Spring mounted footing compl. (1224)	3
	232 975	Spring mounted footing compl. (1225)	3
18	232 976	Tonearm head compl.	1
19	231 992	Contact plate compl. with mass sheet	1
20	201 132	Lift	1
21	210 182	Bowed lockwasher 4.2/8	1
22	210 630	Washer 4.2/8/0.5 St	1
23	210 197	Ring 4/0.8	1
24	215 430	Cartridge mount TK 14 compl.	1
25	232 978	Tonearm rest compl.	1
26	210 361	Hex nut BM 3	3
27	200 718	Compression spring	2
28	210 624	Washer 4.2/7/0.3 St	4
29	201 632	Rubber washer	2
30	200 713	Washer	2
31	200 712	Spring cup	2
32	200 711	Lockwasher	2
33	229 767	Switch lever compl.	2
34	225 096	Dual emblem	1
35	232 999	Blind 1224 compl.	1
	232 998	Blind 1225 compl.	1
36	216 844	Guide	1
37	210 143	Bowed lockwasher 1.5	2
38	218 318	Positioning sleeve	1
39	229 655	Bearing peak	1
40	229 685	Compression spring	1
41	210 469	Machine screw M 3 x 4	3
42	233 004	Dress plate compl. with lifting bolt	1
43	229 631	Adjusting screw	1
44	229 745	Lever compl.	1
45	210 353	Hex nut BM 2	1
46	232 997	Mounting plate compl.	1
47	213 260	Pin	4
48	214 047	Special screw	2
49	214 210	Shipping screw compl.	2
54	233 000	Tonearm compl.	1
55	233 001	Weight compl.	1
56	229 788	Stud	1
57	233 003	Bearing compl.	1
58	232 985	Spring housing compl.	1
59	229 725	Plate	1
60	203 475	Sunk screw M 3 x 8	1
61	229 723	Locating screw	1
62	232 068	Compression spring	1
63	218 043	Washer 3.2/7/0.5 St	2
64	217 438	Threaded rod	1
65	229 721	Locknut	1
66	232 986	Connecting lever bracket compl.	1
67	229 720	Needle	1
68	229 738	Bearing screw compl.	1
69	229 794	Antiskating knob compl.	1

Fig. 24 Exploded view, above chassis

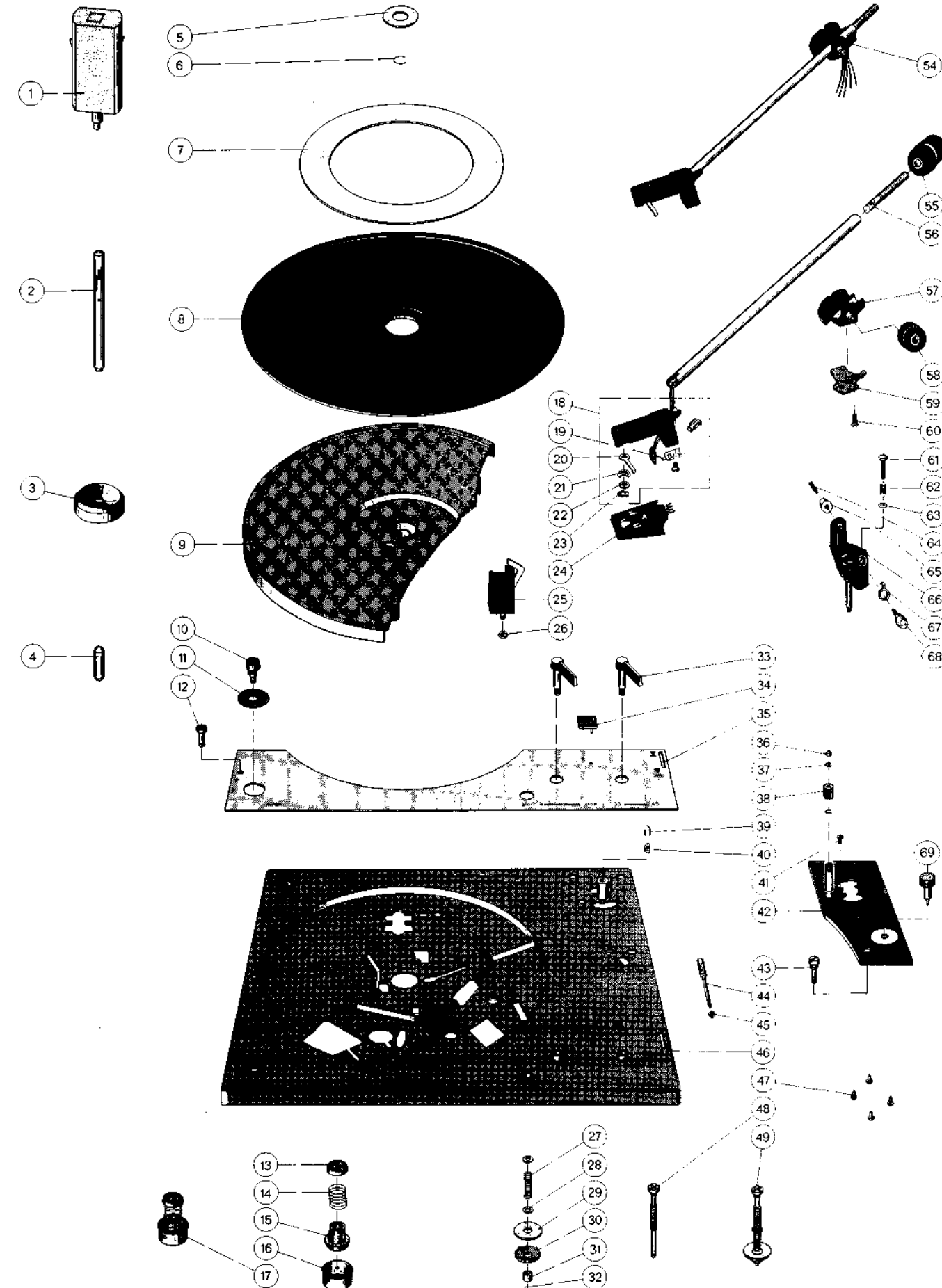
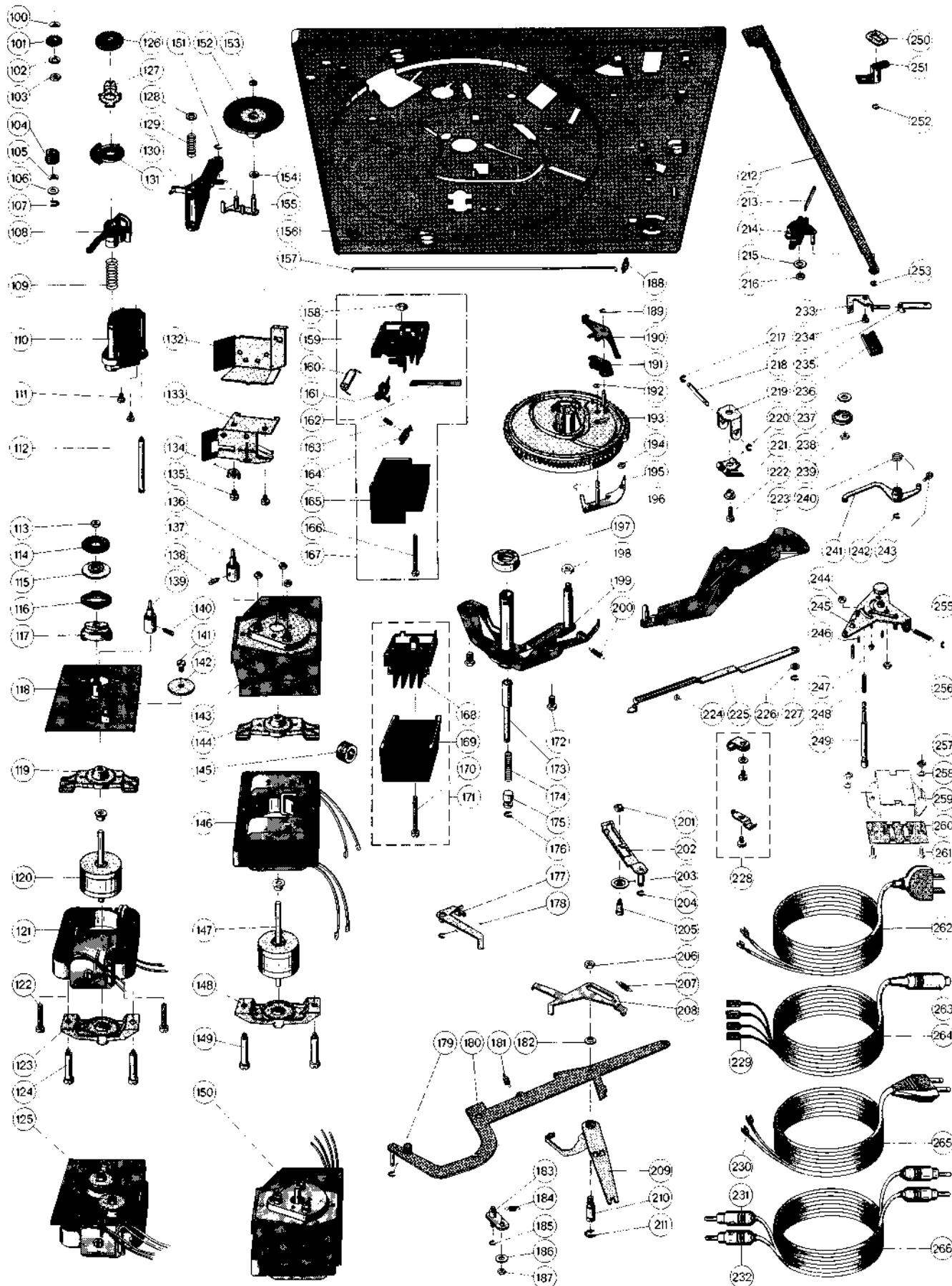

Fig. 25 Exploded view, below chassis



Pos.	Part. No.	Description	Quantity
100	232 439	Spring washer 6.4/11/0.15	1
101	229 373	Adjuster wheel	1
102	210 586	Washer 3.2/7/0.5 ST	1
103	210 362	Hexagon nut BM 3	5
104	228 112	Adjusting wheel	1
105	210 182	Lock washer, thr.	1
106	228 113	Washer 4.2/8/1.0 ST	1
107	210 146	Lock washer 3.2	2
108	229 370	Selector segment	1
109	229 714	Compression spring	1
110	229 663	Bracket complete	1
111	210 472	Fillister head cap screw AM 3 x 4	2
112	229 715	Bearing spindle	1
113	210 369	Hexagon nut M 5	1
114	204 608	Washer	1
115	204 606	Rubber washer	1
116	204 607	Spacing washer	1
117	230 470	Pad 50/60 Hz (1224)	1
118	228 471	Screen plate complete	1
119	233 038	Top bearing bracket complete	1
120	233 023	Rotor complete	1
121	233 027	Stator 110/220 V complete (2-pole-motor)	1
	233 025	Stator 150 V complete (2-pole motor)	1
122	210 522	Fillister head cap screw AM 4 x 18	2
123	233 039	Bottom bearing bracket complete	1
124	228 472	Centering screw	2
125	233 021	2-pole motor AM 203 110/220 V complete	1
	233 022	2-pole motor AM 203 150 V complete	1
126	229 374	Regulator wheel	1
127	229 695	Regulator plate	1
128	210 600	Washer 3.2/8/1 ST	1
129	229 716	Compression spring	1
130	229 672	Change lever	1
131	229 372	Adjustment washer	1
132	229 748	Screen plate	1
133	232 987	Muting switch complete	1
134	211 614	Soldering lug	1
135	210 469	Fillister head cap screw AM 3 x 3	2
136	210 366	Hexagon nut BM 4	3
137	232 898	Motor pulley 50 Hz complete (1225)	1
	232 899	Motor pulley 60 Hz complete (1225)	1
138	230 559	Set screw M 2.5 x 3.5	1
139	232 896	Motor pulley 50 Hz complete (1224)	1
	232 897	Motor pulley 60 Hz complete (1224)	1
	230 559	Set screw M 2.5 x 3.5	1
140	210 472	Fillister head cap screw M 3 x 4	1
141	210 615	Washer 3.2/20/1.5	1
142	228 932	Screen plate	1
143	233 038	Top bearing bracket complete	1
144	209 939	Cable grommet	1
145	233 020	Stator 110/220 V complete (4-pole-motor)	1
146	233 018	Stator 150 V complete (4-pole motor)	1
147	233 016	Rotor complete	1
148	233 039	Bottom bearing bracket complete	1
149	228 472	Centering screw	1
150	233 014	4-pole motor AM 400 110 - 220 V kpl.	1
	233 015	4-pole motor AM 400 150 V kpl.	1
151	210 146	Lock washer 3.2	2
152	217 888	Idler wheel complete	1
153	200 633	Lock washer	1
154	229 719	Slip plate	1
155	229 747	Swinging arm complete	1
156	232 997	Fitting plate complete	1
157	229 660	Control rod	1
158	223 625	Lock washer 3	1
159	233 012	Switch plate complete	1
	233 013	Switch plate UL with special capacitor complete	1
160	209 505	Capacitor 10 nF/1000 V/10 %	1
	230 355	Capacitor 68 nF/ 250 V/20 %	1
161	230 148	Switch slide	1
162	230 151	Slide	1
163	230 296	Tension spring	1
164	219 200	Snap spring	1
165	233 010	Power switch cover complete	1
	233 011	Cover UL complete (for KS 4 with connection plate)	1
166	210 498	Fillister head cap screw M 3 x 28	1

Pos.	Part. No.	Description	Quantity
167	233 009	Power switch complete	1
	233 008	Power switch UL with special capacitor complete	1
168	233 007	Connection plate complete	1
169	233 006	Connection plate cover complete	1
170	210 501	Fillister head cap screw M 3 x 35	1
171	233 005	Connection plate complete with cover	1
172	218 155	Hexagon screw M 4 x 5	2
173	229 753	Change actuator stud complete	1
174	213 920	Compression spring	1
175	213 921	Bush	1
176	210 145	Lock washer 2.3	7
177	229 700	Switch slide	1
178	210 145	Lock washer 2.3	7
179	210 145	Lock washer 2.3	7
180	229 674	Shift arm	1
181	229 698	Tension spring	1
182	210 586	Washer 3.2/7/0.5 ST	7
183	229 690	Start lever complete	1
184	231 017	Tension spring	1
185	210 145	Lock washer 2.3	7
186	210 641	Washer 4.2/10/1 ST	2
187	210 361	Hexagon nut M 3	3
188	200 687	Retainer spring	1
189	210 144	Lock washer 1.9	2
190	229 635	Shut-off lever	1
191	229 756	Friction plate	1
192	210 145	Lock washer 2.3	7
193	232 988	Main cam complete	1
194	200 650	Rubber bush	1
195	229 755	Cam follower lever	1
196	200 522	Snap spring	1
197	229 754	Ball bearing	1
198	210 366	Hexagon nut BM 4	1
199	232 990	Bearing bridge complete	1
200	227 045	Tension spring	1
201	219 049	Square section	1
202	229 758	Paul complete	1
203	229 704	Washer 3.2/13/0.5 ST	1
204	210 145	Lock washer 2.3	7
205	227 060	Bolt	1
206	229 650	Shoulder nut	1
207	229 686	Tension spring	1
208	229 634	Start lever	1
209	229 757	Change lever complete	1
210	229 654	Grooved pin	1
211	210 147	Lock washer 4	1
212	229 629	Positioning slide	1
213	229 649	Leaf spring	1
214	229 759	Adjuster lever	1
215	210 641	Washer 4.1/10/1 ST	2
216	210 361	Hexagon nut M 3	3
217	210 145	Lock washer 2.3	7
218	200 528	Spindle	1
219	229 648	Bearing support	1
220	229 642	Leaf spring	1
221	200 450	Spacer bush	1
222	210 480	Fillister head cap screw AM 3 x 6	1
223	232 993	Main lever complete	1
224	209 358	Ball 4.0	1
225	229 633	Shut-off slide	1
226	201 187	Skating disc	1
227	210 145	Lock washer 2.3	7
228	231 079	Cable clips complete	1
229	209 436	Flat connector	4
230	214 602	AMP connector	4
231	209 425	Cynch plug, white	2
232	209 426	Cynch plug, black	2
233	229 761	Bearing bracket	1
234	232 373	Fillister head cap screw AM 3 x 3	1
235	229 679	Lift cam	1
236	229 680	Brake section	1
237	216 867	Bowed lockwasher	1
238	220 899	Curve washer	1
239	210 361	Hex nut BM 3	3
240	229 688	Torsion spring	1
241	229 796	Skating lever compl. with adjusting screw and torsion spring	1

Pos.	Part.-No.	Description	Quantity
242	210 146	Bowed lockwasher 3.2	2
243	221 260	Adjusting screw	1
244	210 362	Hex nut M 3	5
245	233 002	Segment compl.	2
246	229 772	Threaded pin	1
247	223 777	Guide	1
248	216 853	Compression spring	1
249	229 769	Lifting bolt	1
250	223 146	Securing spring	1
251	229 362	Guide bearing	1
252	210 145	Bowed lockwasher 2.3	7
253	210 145	Bowed lockwasher 2.3	7
255	201 184	Adjusting washer	1
256	218 591	Tension spring	1
257	210 362	Hex nut BM 3	5
258	210 155	Toothed washer A 3.2	2
259	233 089	Shield compl. with insulating plate	1
260	227 254	RCA-type socket plate	1
261	210 480	Machine screw AM 3 x 6	2
262	232 995	Power cable America compl.	1
263	209 424	Miniature plug for audio cable	1
264	207 303	Audio cable compl. with miniature plug and socket for plat prong	1
265	232 996	Power cable Europa compl.	1
266	226 817	Audio cable compl. with RCA-type plugs	1
**	214 120	Hardware for cartridge mounting	1
**	230 747	Shipping carton compl.	1
**	229 987	Mounting instructions	
**	211 473	Stroboscope washer 50/60 Hz	
**	230 582	Operating instructions 1224, 4 languages	
**	230 637	Operating instructions 1225, 4 languages	
**	231 307	Operating instructions 1225 UAP	
**	228 114	Adjusting lever	1

** Not illustrated

Alterations reserved

Fig. 29. Lubrication points above chassis

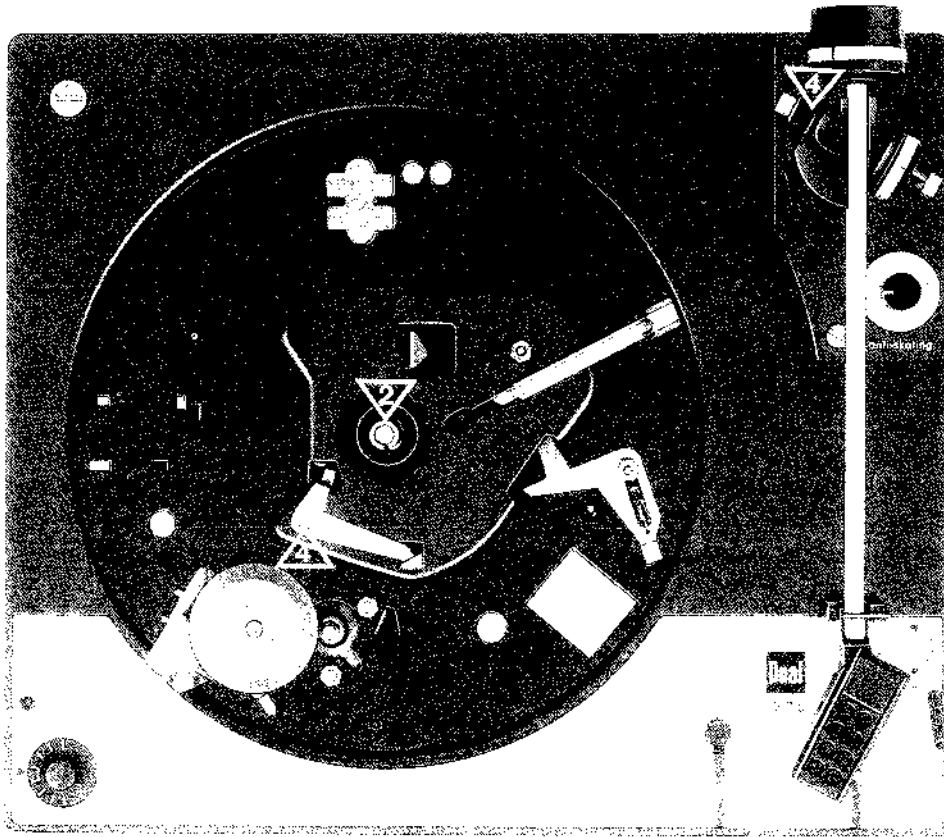

Lubrication

All bearings and friction surfaces have been adequately lubricated at the works. Replenishment of oil and grease is not necessary after about 2 years and normal use as the most important moving points (the bearings) are fitted with oil-proof seals.

The main drive is electric and is connected to the main supply. The motor is a 200-watt, 240-volt, 50-cycle motor. The motor is connected to the main supply through a switch and a fuse. The motor is protected against overload by a thermal relay.

The motor is connected to the main supply through a switch and a fuse. The motor is protected against overload by a thermal relay. The motor is connected to the main supply through a switch and a fuse. The motor is protected against overload by a thermal relay.

The motor is connected to the main supply through a switch and a fuse. The motor is protected against overload by a thermal relay. The motor is connected to the main supply through a switch and a fuse. The motor is protected against overload by a thermal relay.

Fig. 30. Lubrication points below chassis

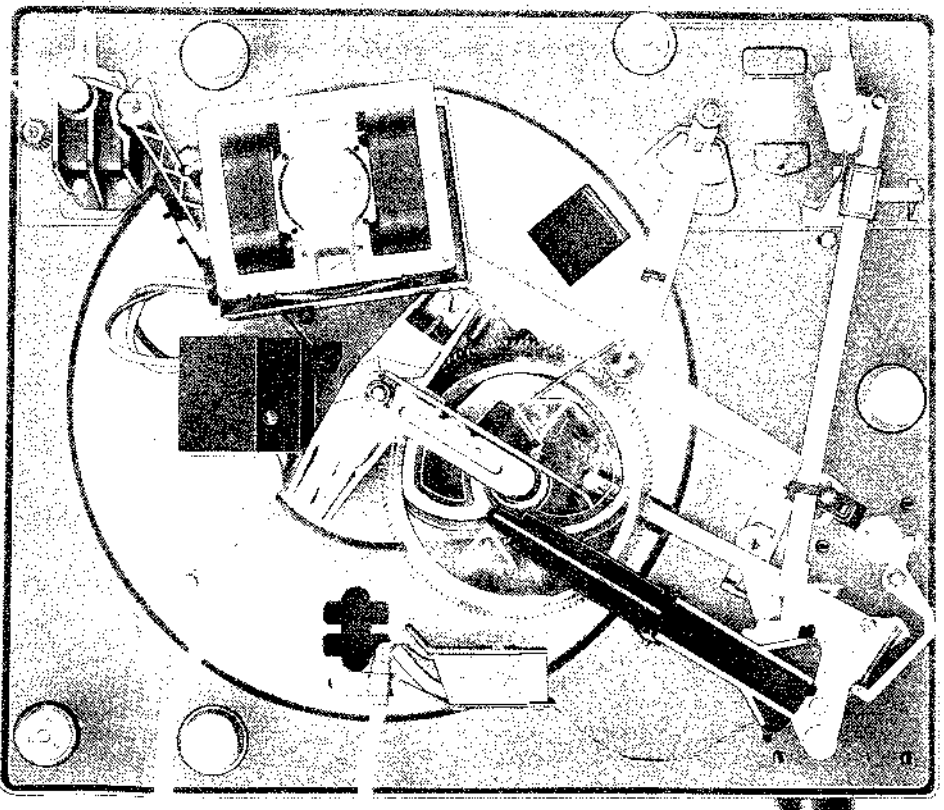

The motor is connected to the main supply through a switch and a fuse. The motor is protected against overload by a thermal relay. The motor is connected to the main supply through a switch and a fuse. The motor is protected against overload by a thermal relay.

The motor is connected to the main supply through a switch and a fuse. The motor is protected against overload by a thermal relay. The motor is connected to the main supply through a switch and a fuse. The motor is protected against overload by a thermal relay.

The motor is connected to the main supply through a switch and a fuse. The motor is protected against overload by a thermal relay. The motor is connected to the main supply through a switch and a fuse. The motor is protected against overload by a thermal relay.

Fig. 26 Lubrication points above chassis

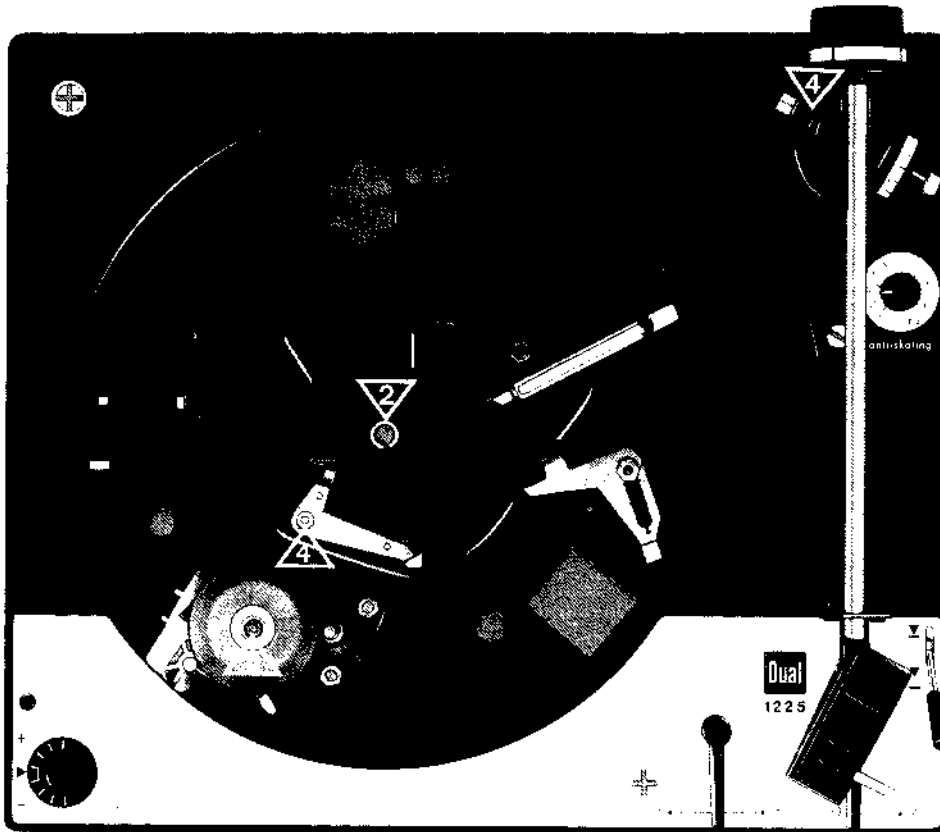

Lubrication

All bearings and friction surfaces have been adequately lubricated at the works. Replenishment of oil and grease is only necessary after about 2 years with normal use as the most important bearing points (motor bearings) are fitted with sintered metal bushes.

Lubricants should be applied sparingly to bearing points and friction surfaces. It is important that no oil or grease should come in contact with the friction faces of the idler wheel, motor pulley and platter as otherwise slip will occur. Avoid touching these parts for the same reason.

When lubricants of different types are mixed, chemical decomposition frequently occurs.

To avoid complications with lubricants we recommend using the original lubricants listed below:

The following lubricants should be used:

Fig. 27 Lubrication points below chassis

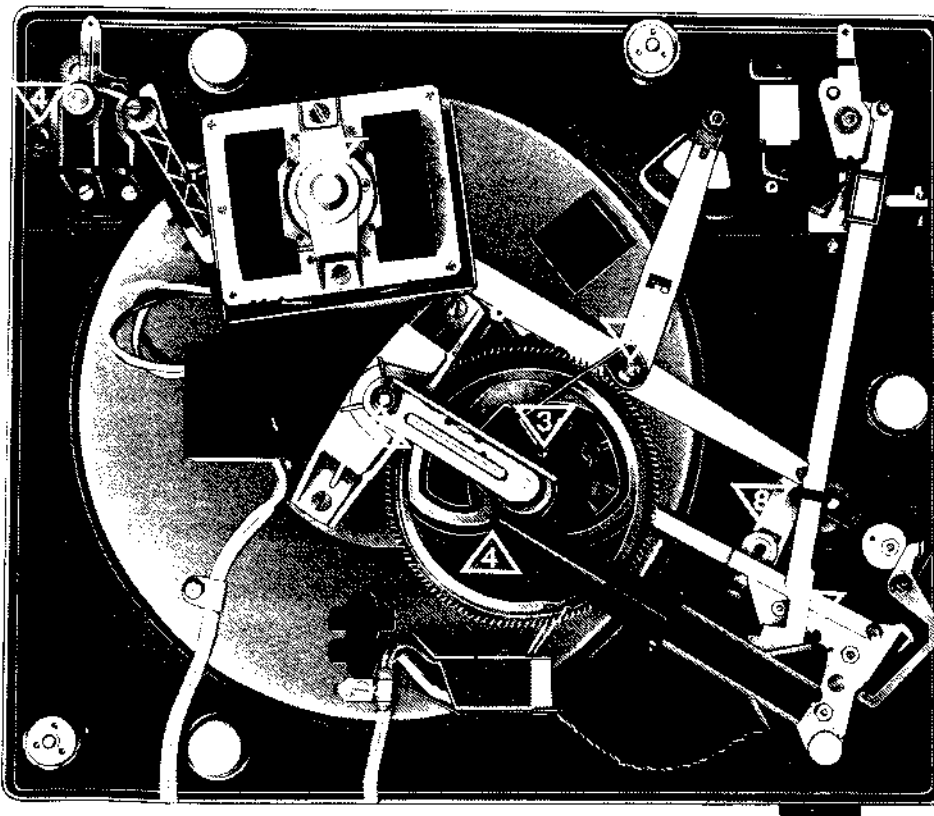

- △ 2 Renotac No. 342 adhesive oil
- △ 3 BP Super Viscostatic 10 W/30
- △ 4 Shell Alvania No. 2
- △ 5 Isoflex PDP 40
- △ 6 Silicone oil AK 500 000
- △ 8 Molykote