

Dual

606

Edition January 1980

Service Manual



Technical Data

Current	AC 50 to 60 Hz
Line voltage	110 to 125 V, 220 to 240 V
Drive	electronically-controlled direct-drive system, Dual EDS 500
Power input	Motor at playing operation approximately 2 watts < 50 mW
Power consumption	220 V 50 Hz: at start 35 mA 110 V 60 Hz: at start 65 mA at play 15 mA at play approximately 25 mA
Time from start to rated speed	2 - 2.5 s at 33 1/3 rpm
Platter	non-magnetic, 1.4 kg, 304 mm diameter
Platter speed	33 1/3 and 45 rpm, electronically adjustable
Pitch control	Separate for both speeds, each adjustable by means of variable resistor, with calibration scale; range of regulation: 10 %
Speed control (monitoring)	with illuminated stroboscope for platter speeds 33 1/3 and 45 rpm, adjustable to 50 or 60 Hz
Sensitivity of the illuminated strobe (for 0.1 % speed deviation)	6 division markings per minute at 50 Hz, 7.2 division markings per minute at 60 Hz,
Total wow and flutter (according to DIN 45 507)	(German Industry Standard) ± 0.05 % WRMS ± 0.03 %
Rumble (according to DIN 45 500)	Unweighted: 50 dB Weighted: 75 dB
Tonearm	Torsionally rigid tubular aluminum tonearm in low-friction four-point gimbal suspension
Effective length of tonearm	221 mm
Offset angle	24° 4'
Tangential tracking error	0.16° /cm
Tonearm bearing friction (related to stylus tip)	vertical < 0.07 mN (0.007 g) horizontal < 0.15 mN (0.015 g)
Stylus pressure	from 0 to 30 mN (0 to 3 g) infinitely variable with 1 mN- (1/10 g) calibrations from 0 to 15 mN (0 to 1.5 g) operable from 2.5 mN (0.25 g) stylus pressure up. with 1/2 inch screw-type attachment. These can be fitted with the special accessories no. 262 186 which can be obtained from trade dealers.
Cartridges	ca. 5.4 kg Dimensions and Cutout Required refer to Installation Instructions.
Weight	

Dual Gebrüder Steidinger · 7742 St. Georgen/Schwarzwald

Contents

Page	
1	Technical data
2	Audio connection diagram
3	Wiring diagram
4	Dual EDS 500 electronic direct drive system
4	Replacement of motor electronics
4	Replacement of motor mechanic
5	Adjustment of nominal speeds
5	Setting 78 rpm nominal speed
5	Stroboscope
5	Pitch control
5	Tonearm and tonearm suspension
6	Removal of tonearm or spring housing
6	Removal of tonearm compl. with tonearm suspension
6	Adjustment of tonearm suspension
6	Fitting a 1/2 inch cartridge
6	Antiscating control
7	Cue control
7	Replacement of cue control assembly
7	Tonearm control
7	Adjustment point
7	Muting switch
8	Starting and shut-off
8	Adjustment points: Segment
8	Power switch
8 – 12	Replacement with exploded views
12	Lubrication

Fig. 1 Audio Connection Diagram

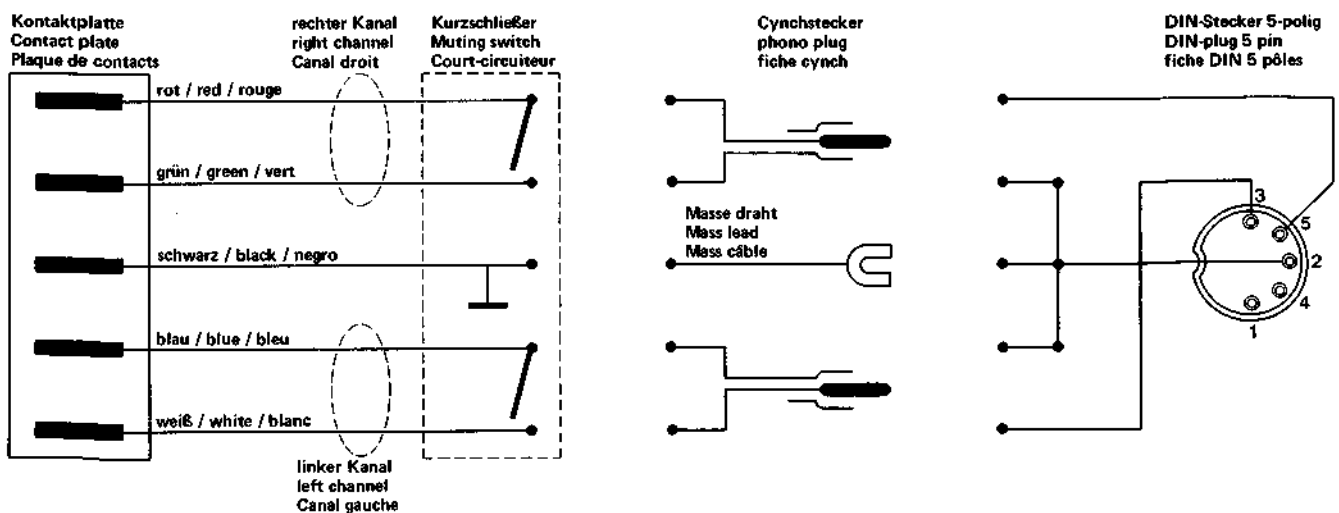
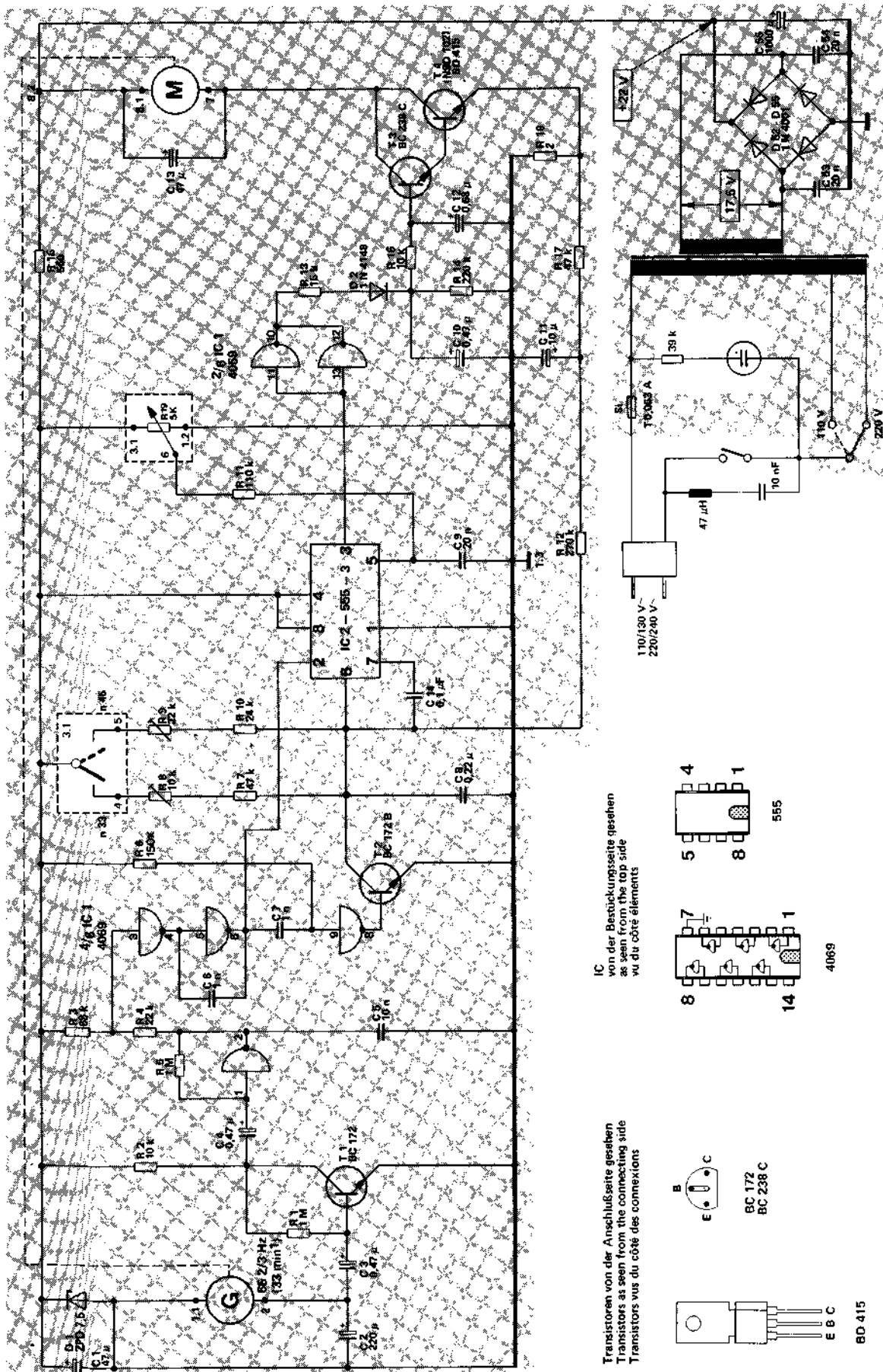
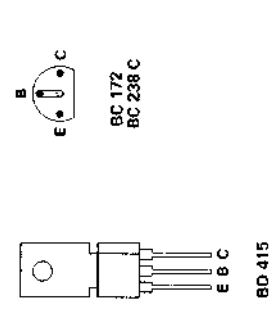
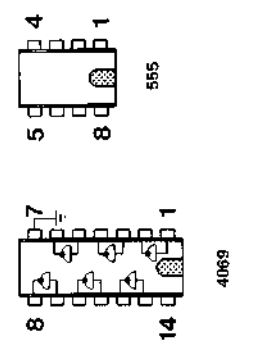

Fig. 2



IC vor der Bestückungsseite gesehen
as seen from the top side
vu du côté éléments

Transistoren von der Anschlußseite gesehen
Transistors as seen from the connecting side
Transistors vu du côté des connexions



R	1	2	3	4	5	6	7	8	9	10	11	12	13	14	15	16	17	18	19	20	21	22	23	24	25	26	27	28	29	30	31	32	33	34	35	36	37	38	39	40	41	42	43	44	45	46	47	48	49	50	51	52	53	54	55	56	57	58	59	60	61	62	63	64	65	66	67	68	69	70	71	72	73	74	75	76	77	78	79	80	81	82	83	84	85	86	87	88	89	90	91	92	93	94	95	96	97	98	99	100
C	1	2	3	4	5	6	7	8	9	10	11	12	13	14	15	16	17	18	19	20	21	22	23	24	25	26	27	28	29	30	31	32	33	34	35	36	37	38	39	40	41	42	43	44	45	46	47	48	49	50	51	52	53	54	55	56	57	58	59	60	61	62	63	64	65	66	67	68	69	70	71	72	73	74	75	76	77	78	79	80	81	82	83	84	85	86	87	88	89	90	91	92	93	94	95	96	97	98	99	100

Fig. 3

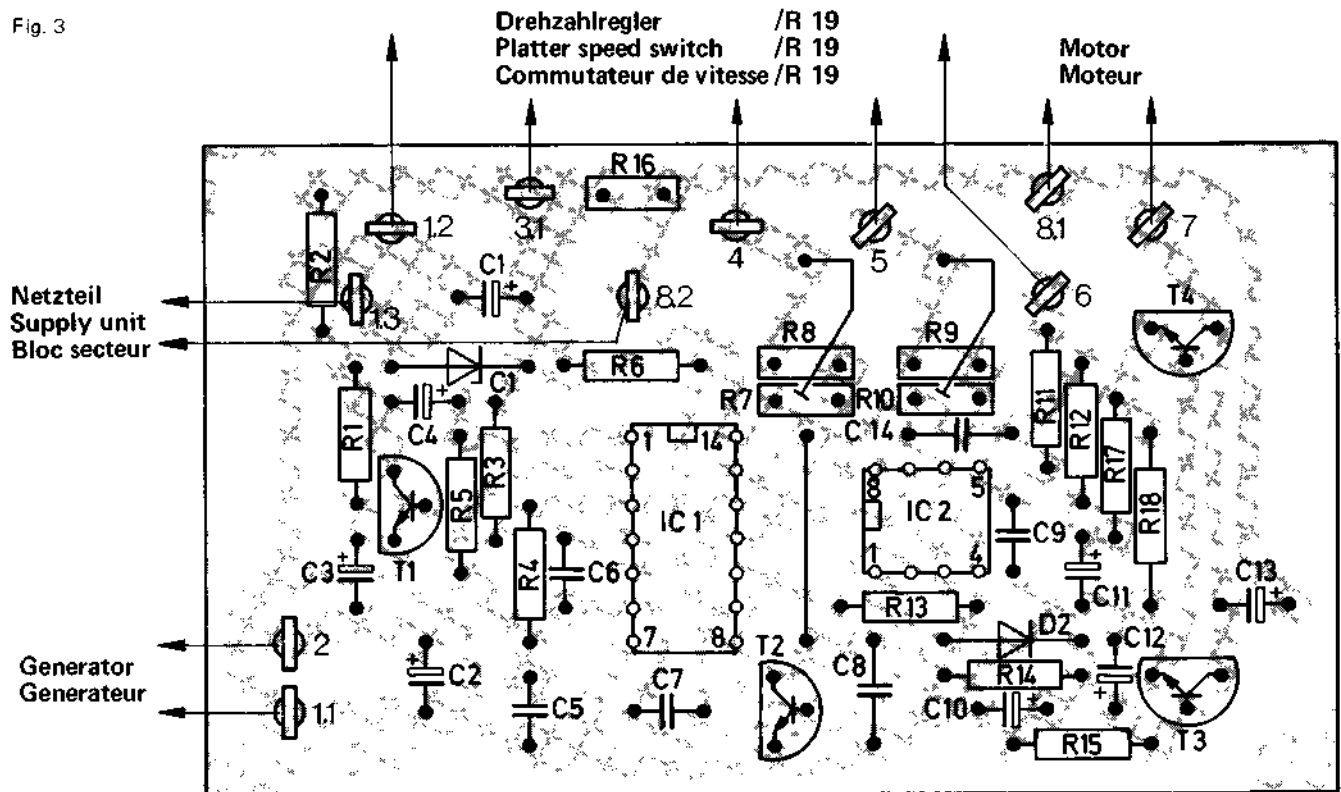

Fig. 4

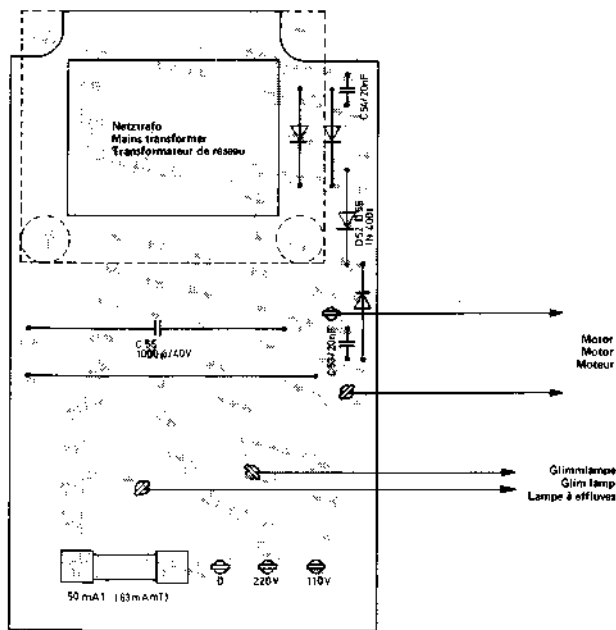
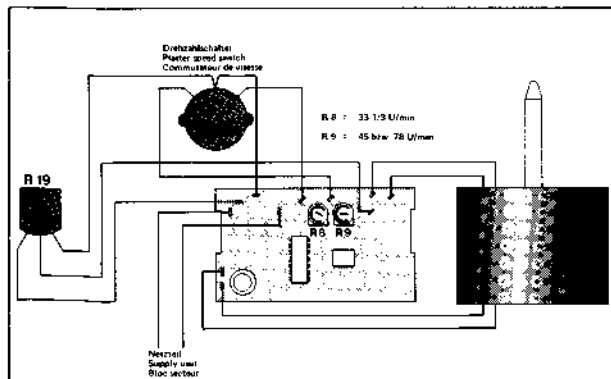

Fig. 5



Direct Drive System Dual EDS 500

For repair of the Dual EDS 500 special tools and measuring means are required. Work on the motor or motor electronics system should, therefore, only be carried out by an authorized Dual service station.

Replacement of motor electronics

1. Extract unit plug from power line. Lift off platter 4. Bring unit into head position
2. Remove machine screws 112 and cover of power part.
3. Unsolder connecting leads to motor and generator. Open twists of holding angle 150 with pliers. Remove motor electronics 152, screws 151 and holding angle 150
4. Pull off motor electronics 152 system from motor 18 carefully
5. Fix replacement motor electronics. Solder connecting cables (see connection diagram Fig. 5).
6. Slide cover over power part and fix it by means of machine screws 112.
7. With the unit in normal position connect it to power line. Switch on unit and check power consumption on operation:
220 V/50 Hz approx. 15 mA
110 V/60 Hz approx. 25 mA

Check nominal speeds. If necessary, readjust as described below.

Replacement of motor mechanics

1. Extract unit plug from power line. Remove platter 4.
2. With the unit in head position remove machine screws 174 and washers 173. Pull off motor electronics board 172 together with cover 175 carefully from the motor 18.
3. Loosen connection for operating voltage at the plate 109. Unsolder connecting leads to speed fine adjustment 129, rotary switch 5 and the generator. Open twists of holding angle 152 with pliers.

4. Loosen threaded pins **13** and remove platter cone **12**. Remove the three screws **148**. Lift off motor mechanics **149**.
5. Put platter cone **12** on new motor mechanics and fix it. Fix new motor mechanics with the three screws **148**. Fix holding angle **150** with screws **151**. Insert motor electronics **152** and twist holding pieces. Solder on resp. plug connecting leads (fig. 5). Push cover on power part and fix it with screws **112**.
6. With the unit in normal position connect it to the power line. Switch on unit and check power consumption when operating:
 - 220 V/50 Hz approx. 15 mA
 - 110 V/60 Hz approx. 25 mA
 Check nominal speeds. If necessary, readjust as described below.

Setting nominal speeds

With knob **7** bring the fine speed control **129/R 19** into center position. With controls **R 8** and **R 9** on the motor electronic system adjust nominal speeds. Control **R 8** is used for 33 1/3 rpm, **R 9** for 45 rpm. Check with strobe disk.

Changeover to 78 rpm nominal speed

Instead of 45 rpm the Dual 606 can be changed to a nominal speed of 78 rpm.

To change the speed bring the fine speed control **129/R 19** in center position using knob **7**. Using control **R 9** on the motor electronics board **152** adjust for 78 rpm. Check with strobe disk.

Stroboscope

Accurate setting of the platter speeds 33 1/3 and 45 rpm can be checked during play with the aid of the stroboscope.

When the platter **4** is rotating at exactly 33 1/3 or 45 rpm the lines of the stroboscope appear to stand still. If the lines move in the direction of rotation of the platter, the platter speed is too high. If the lines move backwards, the platter is rotating more slowly than the nominal speed. Adjustment of platter speeds 33 1/3 and 45 rpm is carried out separately with the "pitch" controls **7**.

Strobe markings are provided on the outer edge of the platter for 50 and 60 Hz line frequencies.

To replace glow lamp **157** remove machine screws **160** and remove strobe cover.

It can happen that the stroboscope lines appear to move slightly although the exact speed setting with stroboscope stationary has not been altered. This apparent contradiction is explained by the fact that the electronic central drive motor operates fully independently of line frequency whilst the only relatively accurate line frequency of the AC current supply is used for speed measurement with the light stroboscope. The constantly detectable fluctuations of line frequency by $\pm 2\%$ according to the information of the electricity supply companies brief frequency fluctuations up to 1% are possible — only effect the stroboscope indication and can cause the lines to "wander" although the platter speed is as constant and absolutely accurate as before.

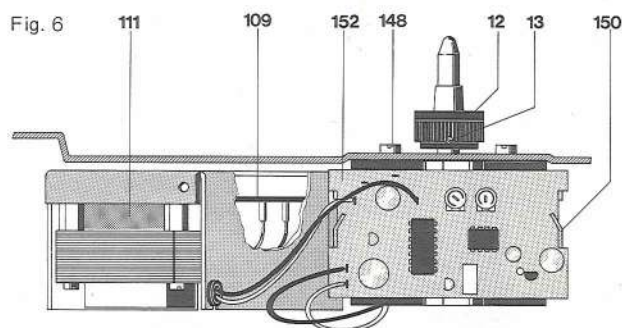

Pitch Control

Each of the two standard speeds 33 1/3 and 45 rpm (78 rpm) can be varied by about 10%. The variable speed control **129/R 19** located in the voltage divider is adjusted by turning the pitch control knob **7**. By this the differential amplifier is altered and the motor speed accordingly.

Fig. 7

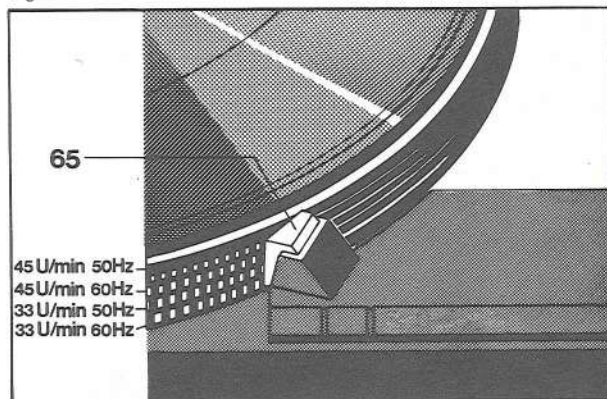

Tonearm and Tonearm Suspension

The feather-light, extremely torsion resistant all-metal tonearm is suspended in a gimbal. Suspension is by means of **4** hardened and precision polished steel points which rest in precision ball bearings. Tonearm bearing friction is thus reduced to a minimum.

Bearing friction vertical 0.07 mN (0.007 p)
 Bearing friction horizontal 0.16 mN (0.016 p)

as related to stylus point.

As a result, it ensures most favourable pick-up conditions. Before adjusting the tracking force to suit the built-in pick-up cartridge the tonearm is balanced with the scale set to zero. Coarse adjustment is carried out by moving the weight with the stem **49**, the subsequent fine adjustment by turning the weight.

The tracking force is adjusted by turning the graduated spring housing **58** incorporating a coil spring. The Rotary knob **54** has markings for a range of adjustment from 0 to 30 mN (0 to 3 p) which permit accurate adjustment of the tracking force. One graduation in the range of 2 – 15 mN (0.2 – 1.5 p) corresponds to 1 mN (0.1 p), in the range of 15 – 30 mN (1.5 – 3 p) to 2.5 mN (0.25 p).

Fig. 8

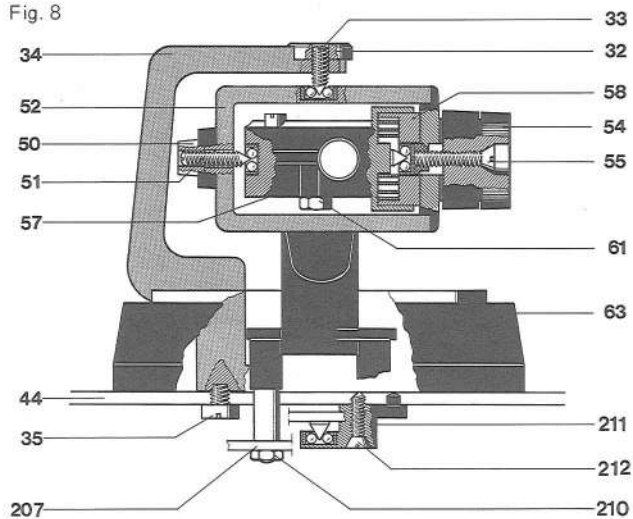

Fig. 9

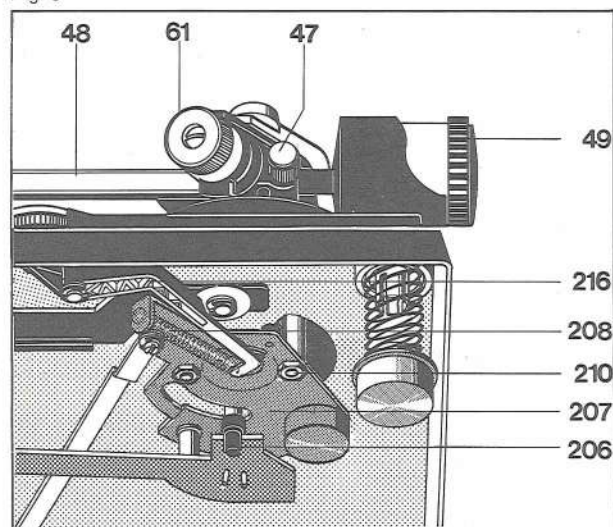
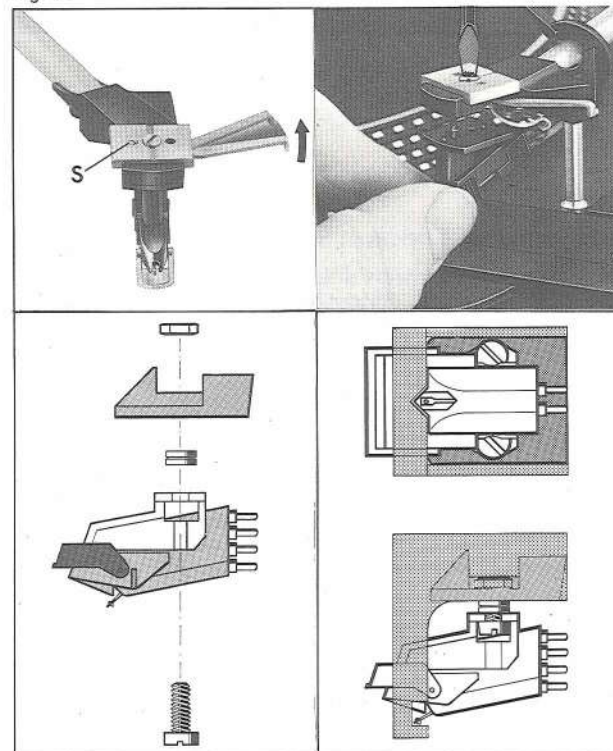

Fig. 10



To Remove the tonearm or the spring housing

1. Secure the unit in a repair stand. Turn the rotary turn switch **51** to the zero position. Lock the tonearm **48**. Remove the counterweight **49**.
2. Turn the unit over. Remove the screening sheet **140** and solder off the tonearm connections at the short circuiter **137**. Turn the unit the right way up.
3. Remove the fillister head screw **55**. Remove the rotary turn switch **54** and the washer **53**.
4. Loosen the nut **50** and the grub screw **51**. Draw the tonearm **48** complete with bearing **57** from the bearing race **52**. The spring housing **52** or the tonearm **48** may now be changed.

Reassembly involves the reverse procedure.

Removing the tonearm from the bearing frame

We recommend the following procedure:

1. Clamp unit in the repair stand. Set rotary knob **54** to zero. Lock tonearm **48**. Remove weight **49**.
2. Turn unit over and remove the screening sheet **140**. Unsolder the tonearm connections on the muting switch **137**.
3. Remove safety washer **187**, washer **186** and bearing **185**. Move positioning bar **219** towards muting switch **137**.
4. Unlock tension spring **203**, loosen safety washer **217** and remove skating lever **216**.
5. Remove safety washer **214** and sliding washer **213** and take shut-off bar **161** from segment.
6. Slacken hex nuts **210** and the screw **212**. Remove the bearing **211** and segment **207**.
7. Hold tonearm **48**. Remove the machine screw **35** and tonearm cpl. with tonearm bearing.

Reassembly of the tonearm involves the reverse procedure. Take care that the grub screw **33** is correctly seated in the bearing when fastening the frame **34**.

Adjusting the tonearm bearing

First balance tonearm exactly. Both bearings must have slight, just perceptible play. The horizontal tonearm bearing is correctly adjusted when at anti-skating settings "0.5" and being touched it slides in without resistance. The vertical tonearm bearing is correctly adjusted when it swings in after being touched. The play of the horizontal tonearm bearing should be adjusted with threaded pin **33** and mat of the vertical tonearm bearing with threaded pin **51**.

Fitting a 1/2 inch cartridge

If a cartridge with 1/2 inch standard mount is to be fitted, the conversion kit **31** Number 262 186 is necessary. The proper method of fitting is shown in fig. 8.

Also the decorative cover should be removed from the counterweight **49** and should be fitted with the compensatory weight to be found in the conversion kit **31**.

Any alteration can only be carried out with the aid of a Dual-Skate-0-Meter and a test record and should only be done by an authorized service station.

Anti-skating Device

To compensate for skating force use the knurled ring **68**. The asymmetric cam plate displaces the skating lever **216** from the tonearm pivoting point. The anti-skating force is transmitted to the segment **207** and to the tonearm **48** by tension spring **208**. Optimum adjustment is carried out at the works for styli having a tip radius of 15 μm (conical), 5/6 and 18/22 μm (elliptical). Any alteration can only be carried out with the aid of a Dual-Skate-0-Meter and a test record and should only be done by an authorized service station.

Cue Control

By moving the lever **194** forward (▼) lift cam **197** rotates. The slide bar **219** connected to it transmits this movement to the lift pin **206** (via the compensating cam which then raises the tonearm. As a result, the cue control permits setdown of the tonearm at any desired point

The lever **194** is released by moving the cue control lever rearwards (▲) As a result of the action of compression spring **204** the lift pin **201** is brought back to its normal position and the tonearm lowered slowly. Lowering of the tonearm is damped by silicone oil in the lift tube.

Adjustment Point

The lift height may be varied by turning the sleeve **202** The distance between the record and the needle is to be 5 - 7 mm.

Replacement of Cue Control Plate

Replace cue control plate **201** as follows:

1. Clamp unit in the repair stand and lock tonearm. Turn unit over
2. Remove safety washer **187**, washer **186** and bearing **185** Lift positioning bar **219** and move towards muting switch **137**.
3. Unlock tension spring **208**. Loosen safety washer **217** and lift skating lever **216**. Remove safety washer **214** and sliding bar **213**. Lift shut-off bar **161** from segment **207**.
4. Remove hex nuts **210** and the screw **212**, and the counter bearing **211** and segment **207**.
5. Remove machine screws **205** and remove lift plate **201**.

Reverse this procedure when reassembling.

Tonearm set-down mechanism

When turning knob **62** to "V" position the recesses of slide bar **219** are positioned in the area of the spring pin **F** of segment **207**.

When moving slowly the tonearm with tonearm cue control in ▼ position the spring pin **F** is arrested in the recesses of slide bar **217** thus designing the set-down point of stylus for 30 cm and 17 cm records.

To enable set-down in the catching range of the arresting point of the appropriate setdown position, the tonearm set-down mechanism can be disengaged with the knob **62** in "—" position.

Adjustment Points

- a) Balance tonearm **48** exactly. Bring knob **62** into "V" position. Let tonearm catch in catch point for tonearm set-down point. Check catch force by means of a spring balance. It should read 10 - 20 p. The force is adjustable by means of a threaded pin
- b) The tonearm set-down point can be adjusted by turning set screw **45** Adjustment can be made for 17-cm- and 30-cm records.

Short Circuiter

To prevent disturbing noises during automatic operation of the tonearm the unit is fitted with a short circuiter. Control of the switch springs for both channels is effected by the camwheel. With the unit in neutral state the short circuit of the pick-up leads is eliminated

Adjustment

In zero position of the cam there should be a clearance of approximately 0.5 mm between the contacts of the short circuiter. This clearance should be adjusted by bending the short circuit contact. The contacts should be sprayed with a suitable cleaning agent.

Fig. 11

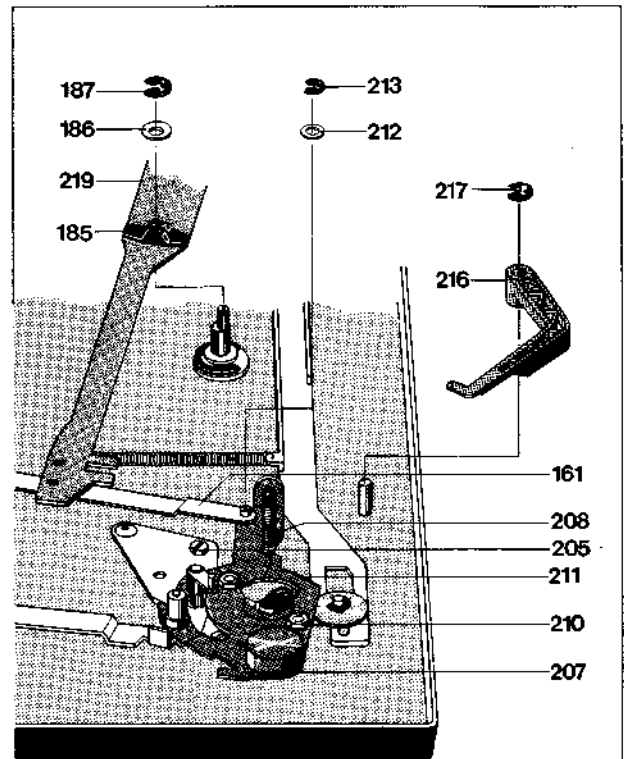

Fig. 12

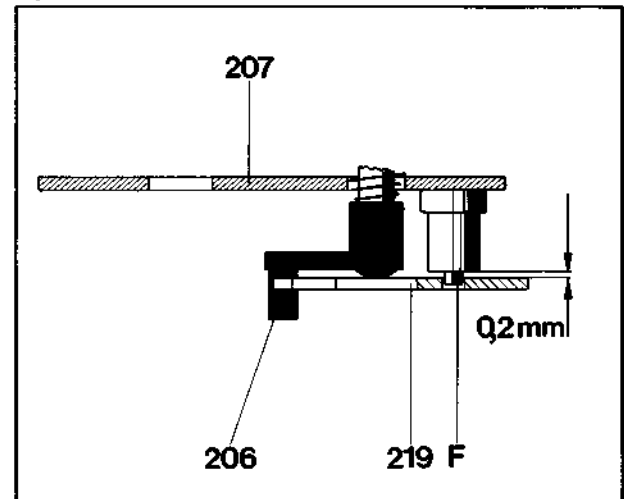
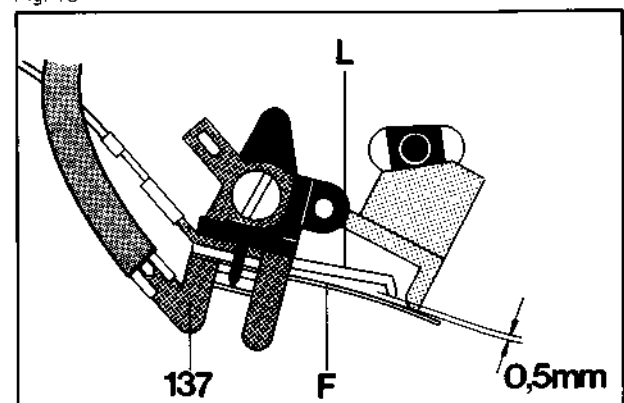

Fig. 13



Starting and shut off

Swinging in the tonearm 48 rotates the segment 207 thus actuating the power switch 116 and shift arm 146 and starting motor 149 and platter 4 rotating.

The shut-off cycle after playing a record is initiated by the dog M of the platter 4 and shut-off lever A.

The shut-off lever A is guided onto the dog by the movement of the tonearm when playing the record with the aid of the shut-off bar 161 proportionate to the groove lead. The eccentrically-mounted dog forces the shut-off lever A back with each revolution as long as the advance of the tonearm only amounts to the width of one groove.

The cam wheel 37 is thus guided to the pinion range of the platter. The tonearm is lifted and the resetting bar 188 transports it back to the rest. The power switch is operated, thus switching the unit off.

Fig. 14

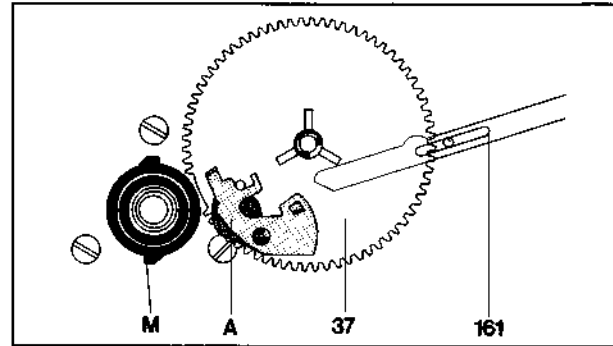

Adjustment Points

Power Switch

Swing in tonearm 48 slide 117 of power switch 116 should have a play of 0.2 – 0.5 mm. Make adjustments by bending the switch lever 144.

Segment

- When fixing the segment 207 mowe surt here is a play between the segment 207 and the switch lever 144 of 0.5 mm.
- The shut-off point may be varied with the eccentric E mounted on the segment.

Fig. 15

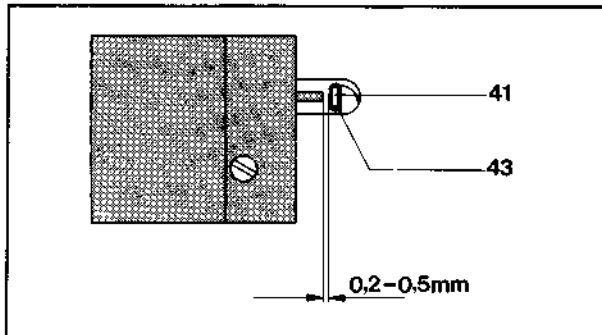
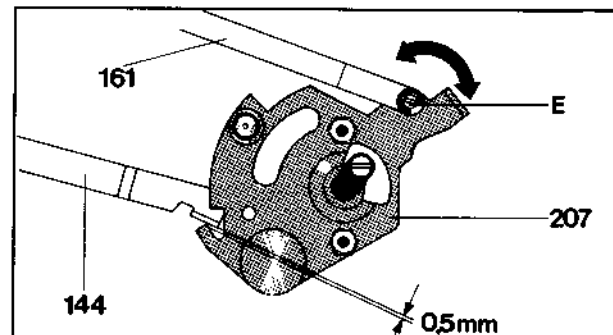

Fig. 16



Replacement parts

Pos.	Part.No.	Qty	Description
1	220 213	1	Centering piece
2	214 056	1	Washer
3	263 254	1	Platter mat cpl.
4	263 256	1	Platter cpl.
5	238 034	1	Switch
6	260 335	1	Rotary knob
7	260 336	1	Rotary knob
8	242 191	3	Grub screw M 3 x 3
9	263 257	1	Pitch cover
10	200 444	8	Spring washer
11	239 414	3	Shipping screw cpl.
12	242 192	1	Platter cone cpl.
13	242 191	3	Grub screw M 3 x 3
14	262 634	1	Washer 3.2/15/0.6
17	232 975	3	Spring mount cpl.
	237 228	1	Spring mount cpl. (Tonearm side front)
18	230 529	9	Threaded piece
19	230 523	3	Compression spring
	236 712	1	Compression spring (Tonearm side front)
20	200 723	4	Rubber damping
21	200 722	4	Steel cup
25	263 259	1	Tonearm head cpl.
26	261 929	1	Tonearm lead cpl.
31	262 186	1	1/2 inch conversion kit cpl.
32	249 383	1	Counter nut
	262 695	1	Counter nut
33	234 651	1	Grub screw
34	263 081	1	Frame cpl.
35	242 677	1	Machine screw M 4 x 8
37	244 464	1	Cam wheel
38	210 146	4	Lock washer 3.2
39	242 143	1	Tension spring
40	210 145	5	Lock washer 2.3

Pos.	Part.No.	Qty	Description
41	242 141	1	Contact lever
44	263 339	1	Mounting plate
45	234 781	1	Adjustment
46	234 818	1	Pin screw
47	200 428	1	Clamping screw
48	264 020	1	Tonearm cpl.
49	263 263	1	Weight cpl.
	263 328	1	Weight cpl. (UAP)
50	246 884	1	Counter nut
51	234 634	1	Grub screw
52	263 329	1	Bearing frame cpl.
53	261 798	1	Washer 5.2/10
54	248 989	1	Rotary knob
55	249 097	1	Raised counter sunk head screw M 2.5 x 12
56	236 069	1	Machine screw
57	263 340	1	Bearing cpl.
58	263 339	1	Spring housing cpl.
59	248 979	1	Lifting plate
60	210 597	1	Washer 3.2/8/0.5
61	262 294	1	Hexagon sheet screw B 2.9 x 6.5
62	260 334	1	Rotary knob
63	263 341	1	Rear covering cpl.
65	260 328	1	Stroboscope prism
66	263 342	1	Front covering cpl.
67	263 334	1	Tonearm rest cpl.
68	260 320	1	Cam disc
69	242 298	1	Washer
70	228 113	1	Washer 4.2/8/1
71	210 146	3	Lock washer 3.2
72	200 444	4	Spring washer

Fig. 17 Exploded view 1

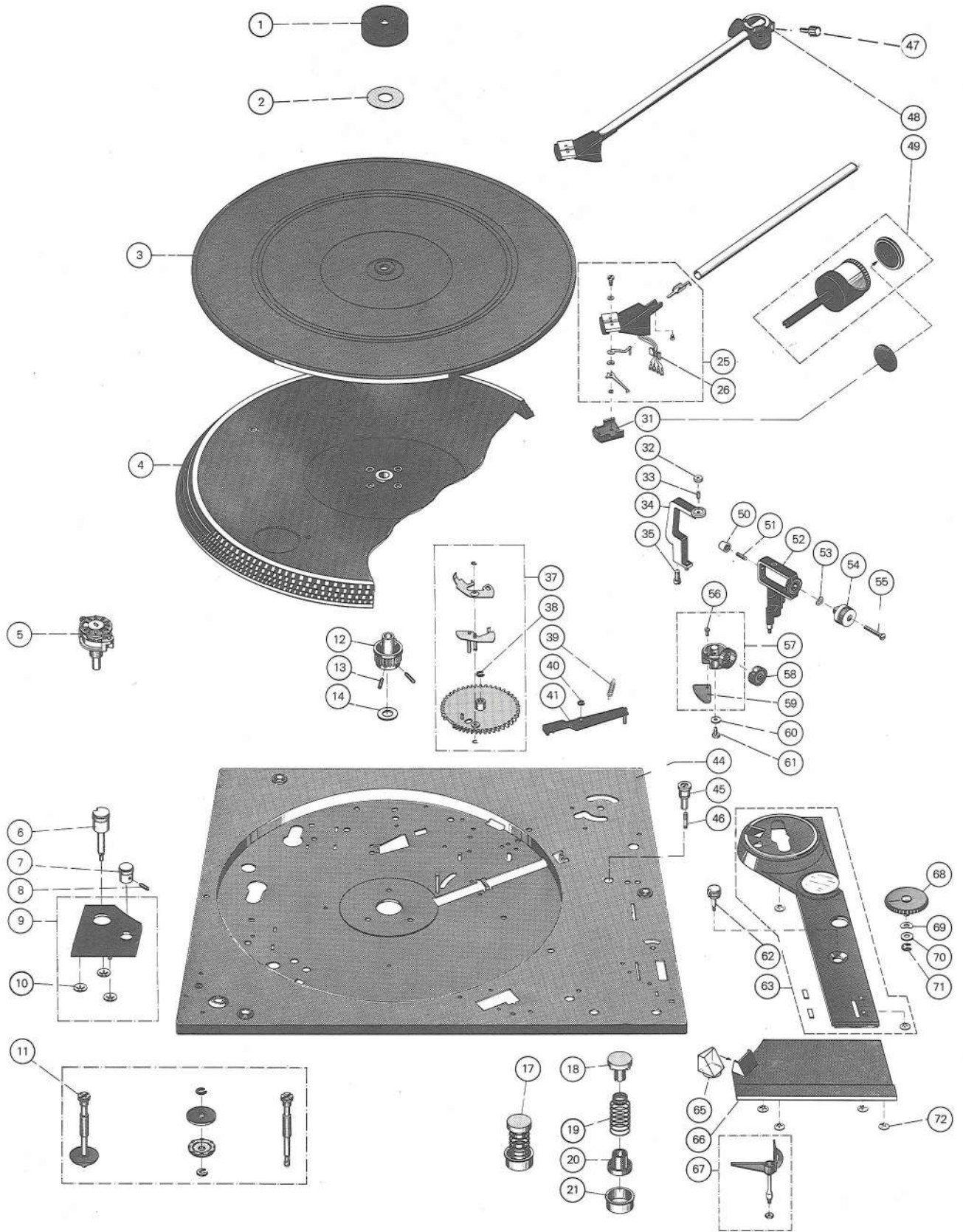
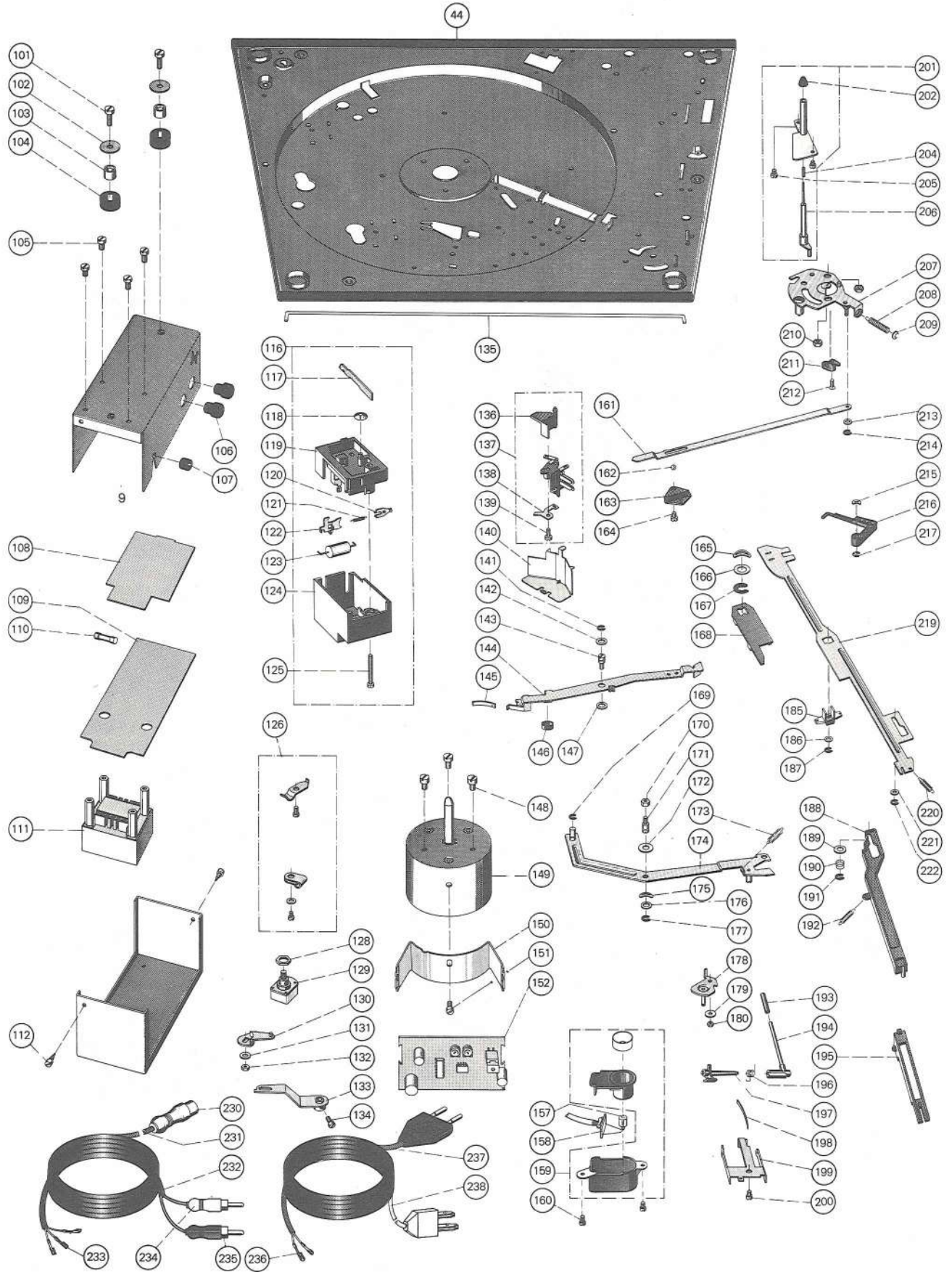

Fig. 18 Exploded view 2



Pos.	Part.No.	Qty	Description
101	210 517	2	Machine screw M 4 x 10
102	210 648	2	Washer 4.2/14/1
103	242 283	2	Bushing
104	209 939	2	Sleeve
105	210 480	4	Machine screw AM 3 x 6
106	237 548	2	Sleeving with strain relief
107	228 209	1	Sleeve
108	242 284	1	Insulating plate
109	263 338	1	Power plate cpl.
110	242 478	1	Fuse T 0.063 A
C 53	222 760	2	Ceramic 20 nF/ 50 V
C 54	222 760	2	Ceramic 20 nF/ 50 V
C 55	226 686	1	Elyt 1000 µF/ 40 V
D 52	227 344	4	1 N 4001
D 53	227 344	4	1 N 4001
D 54	227 344	4	1 N 4001
D 55	227 344	4	1 N 4001
111	244 474	1	Power transformer cpl.
112	210 283	2	Fillister sheet screw
116	242 581	1	Power switch cpl.
117	236 335	1	Slide
118	200 444	1	Spring washer
119	233 012	1	Switch plate cpl.
120	219 200	1	Snab spring
121	239 732	1	Tension spring
122	230 148	1	Switch angle
123	241 883	1	Capacitor 10 nF/250 V
	242 828	1	RF-cocke 47 µH
124	242 102	1	Cap
125	210 498	1	Machine screw M 3 x 28
126	231 079	1	Cable holder cpl.
128	237 782	1	Nut for potentiometer
129	238 073	1	Fine speed control (R)
130	242 195	1	Switch unit
131	210 587	1	Washer 3.2/7/1
132	210 362	1	Hex nut BM 3
133	242 187	1	Switch member
134	210 469	1	Machine screw AM 3 x 3
136	242 182	1	Contact arm
137	242 612	1	Short circuiter cpl
138	239 806	1	Base sheet
139	210 486	1	Machine screw AM 3 x 8
140	239 808	1	Screening sheet
141	210 146	1	Lock washer 3.2
142	210 630	1	Washer 4.2/8/0.5
143	234 759	1	Screw pin
144	242 142	1	Switch lever
145	242 144	1	Spring
146	242 145	1	Silicone tubing
147	210 630	1	Washer 3.2
148	210 511	3	Machine screw AM 4 x 4
149	244 476	1	Motor mechanics cpl.
150	242 233	1	Stop angle
151	210 511	1	Machine screw AM 4 x 4
152	244 477	1	Motor electronics cpl.
157	260 421	1	Glow lamp
158	249 092	1	Plate
159	263 336	1	Stroboscope housing
160	210 469	2	Machine screw AM 3 x 3
161	242 179	1	Stop lever
162	209 357	1	Ball φ 3.2
163	232 104	1	Ball bad
164	210 472	1	Machine screw AM 3 x 4
165	234 782	1	Lock washer
166	210 713	1	Washer 9.1/15/1
167	210 151	1	Lock washer 7
168	242 180	1	Plate
169	210 145	1	Lock washer
170	210 366	1	Hex nut M 4
171	242 175	1	Screw pin
172	210 607	1	Washer 3.2/10/0.5
173	233 710	1	Tension spring
174	242 171	1	Lever
175	210 182	1	Lock washer
176	210 630	1	Washer 4.3/3/0.5

Pos.	Part.No.	Qty	Description
177	210 146	4	Lock washer 3.2
178	242 164	1	Rotary lever
179	203 477	1	Washer 2.7/8/1
180	210 353	1	Hex nut M 2
185	234 784	1	Bearing
186	210 586	1	Washer 3.2
187	210 145	5	Lock washer 2.3
188	242 165	1	Rail
189	242 166	1	Washer 3.2/14/0.5
190	243 001	1	Compression spring
191	210 145	5	Lock washer 2.3
192	242 167	1	Tension spring
193	237 543	1	Rubber sleeve
194	239 547	1	Handle
195	242 161	1	Lift rail
196	234 778	1	Spring
197	234 777	1	Shift curve
198	232 545	1	Spring
199	234 776	1	Bearing lever
200	210 469	1	Machine screw AM 3 x 3
201	263 343	1	Lift plate cpl.
202	243 125	1	Adjustment bush
204	234 798	1	Compression spring
205	210 469	1	Machine screw AM 3 x 3
206	234 795	1	Lift pin
207	263 344	1	Segment cpl.
208	218 591	1	Tension spring
209	201 184	1	Adjustment washer
210	210 362	2	Hex nut M 3
211	242 615	1	Counter bearing
212	201 187	1	Washer
213	210 145	5	Lock washer 2.3
214	242 298	1	Lock washer
215	244 331	1	Skating lever cpl.
216	210 146	4	Lock washer 3.2
219	242 181	1	Adjustment lever
220	235 152	1	Tension spring
221	210 607	1	Washer 3.2
222	210 145	5	Lock washer 2.3
230	209 424	1	Spole plug
231	207 303	1	Pick-up-cable cpl.
232	207 301	1	Pick-up-cable cpl.
233	209 436	3	Falt connector sleeve
234	209 425	1	Cynch plug white
235	209 426	1	Cynch plug black
236	214 602	2	AMP- connector sleeve
237	232 996	1	Power cable europe cpl.
238	232 995	1	Power cable america cpl.
	261 952	1	CK 28 walnut console cpl.
	261 953	1	CK 28 agate black console cpl.
	261 954	1	CK 28 agate brown console cpl.
	227 986	1	Cover CH 6 cpl.
	260 343	1	Operating instructions
	261 826	1	Operating instructions UAP
	260 359	1	Shipping carton CS
			Motor electronic
C 1	220 766	4	Elyt 47 µF/ 25 V
C 2	224 597	1	Elyt 220 µF/ 6 V
C 3	216 410	3	Elyt 470 nF/ 35 V/10 %
C 4	216 410	3	Elyt 470 nF/ 35 V/10 %
C 5	227 963	1	Ceramic 10 nF/ 30 V/20 %
C 6	227 390	2	Ceramic 1 nF/ 63 V/20 %
C 7	227 390	2	Ceramic 1 nF/ 63 V/20 %
C 8	222 499	1	Foil 0.22 µF/100 V/ 5 %
C 9	222 760	1	Ceramic 20 nF/ 50 V
C 10	216 410	3	Elyt 470 nF/ 35 V/10 %
C 11	235 573	1	Elyt 10 µF/ 16 V
C 12	242 314	1	Elyt 0.68 µF/ 35 V
C 13	220 766	4	Elyt 47 µF/ 25 V
C 14	226 459	1	Foil 0.1 µF/100 V/ 5 %
D 1	227 360	1	ZPD 7.5
D 2	223 906	1	1 N 4148
R 1	224 603	3	1 MΩ /0.25 W/5 %
R 2	211 202	4	10 kΩ /0.25 W/5 %
R 3	224 735	1	68 kΩ /0.25 W/5 %

Pos.	Part.No.	Qty	Description
R 4	239 387	1	22 k Ω /0.25 W/5 %
R 5	224 603	3	1 M Ω /0.25 W/5 %
R 6	241 342	1	82 k Ω /0.25 W/5 %
R 7	242 307	1	Potentiometer 47 k Ω
R 8	243 616	1	10 k Ω / lin.
R 9	243 617	1	22 k Ω / lin.
R 10	245 531	1	Potentiometer 24 k Ω
R 11	227 384	1	110 k Ω /0.125 W/5 %
R 12	228 265	1	270 k Ω /0.25 W/5 %
R 13	239 395	1	15 k Ω /0.25 W/5 %
R 14	224 590	1	220 k Ω /0.25 W/5 %

Pos.	Part.No.	Qty	Description
R 15	211 202	4	10 k Ω /0.25 W/5 %
R 16	217 868	1	560 Ω /0.3 W/5 %
R 17	239 367	1	47 k Ω /0.25 W/5 %
R 18	242 311	1	2 Ω /25 W/5 %
T 1	229 511	2	BC 172 B
T 2	229 511	2	BC 172 B
T 3	244 715	1	BC 238 C
T 4	242 306	1	BD 415
IC 1	242 303	1	NS 4069
IC 2	242 304	1	NS 555

Alterations reserved!

Fig. 19

Lubrication

All bearings and friction points are adequately lubricated by the manufacturer. Replenishment of oil and grease is only necessary after approximately 2 years of normal use of the turntable as the most important bearing points (motor bearings) have sintered metal bushes.

Bearing points and friction faces should be lubricated sparingly rather than generously.

When using different lubricants, chemical decomposition can often occur. To prevent failure of lubrication we recommend using the original lubricants stated below.

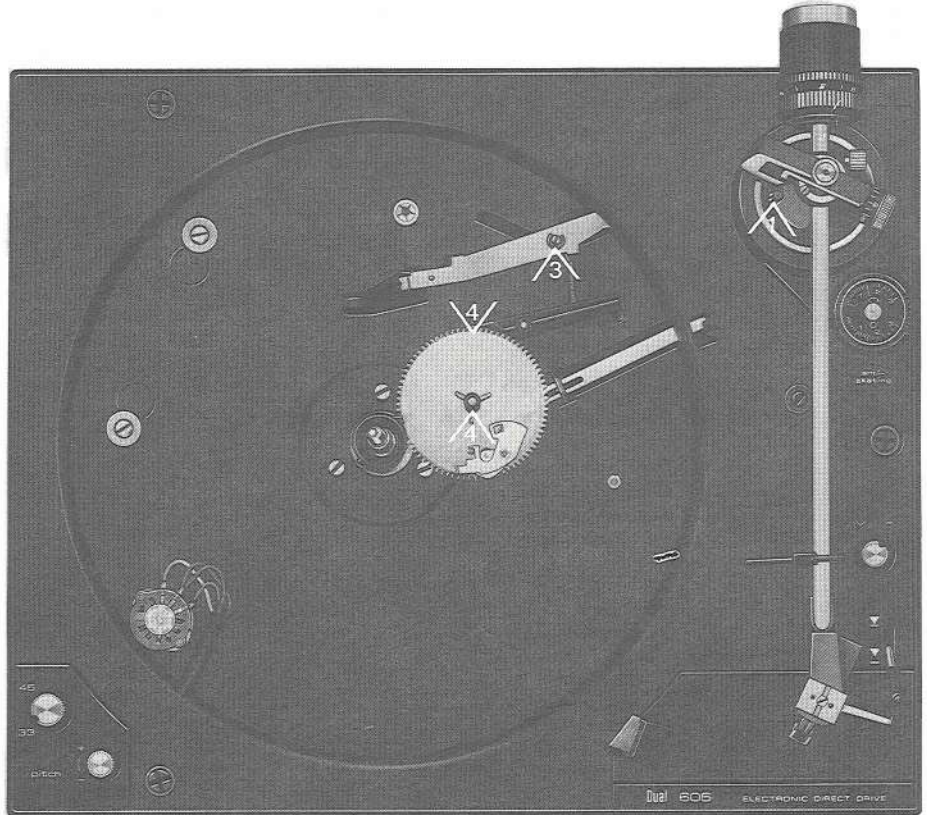

Fig. 20



Wacker silicon oil
AK 300 000



BP super viscostatic
10 W/40



Shell alvania No. 2

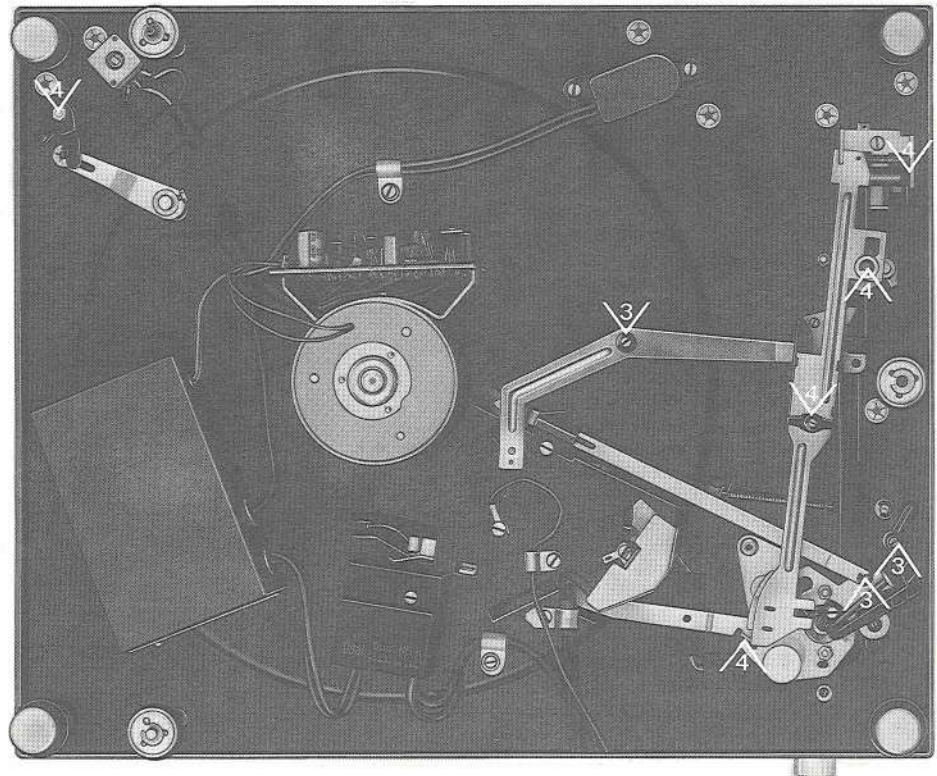

Service Information

Instructions de service



Ausgabe Juni 1980

Die Geräte sind mit einer neuen Drehzahlumschaltung ausgerüstet!

The units are equipped with a new speed control switch!

Les appareils sont équipés d'un nouveau commutateur de vitesse!

606

622

CS 626

CS 650

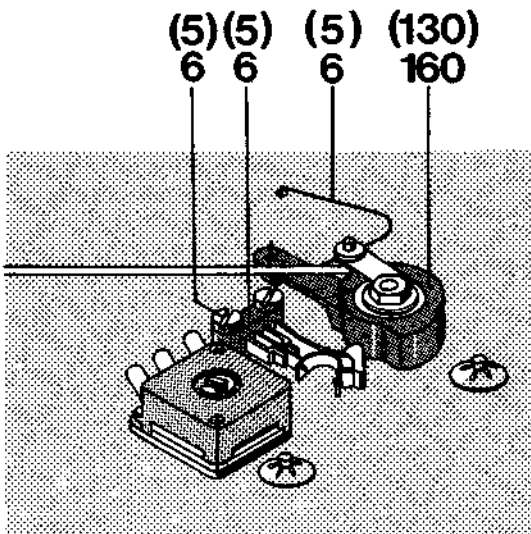

Gerät Model Appareil	606	622	CS 626	CS 650		
Geräte-Nr. Serial number No. de l'appareil	58 000	26 150	34 740	22 325	Bezeichnung Description Désignation	Art.-Nr. Part-No. Référ.
Pos.	5	5	6	6	Mikroschalter Micro switch Interrupteur miniature	244 889
	130	130	160	160	Schaltstück Contact piece Pièce de couplage	262 868
	5	5	6	6	Zylinderschraube M 3 x 8 Machine screw Vis cylindrique	210 486
	5	5	6	6	Schaltfeder Switch spring Ressort de commutation	262 869

Dual Gebrüder Steidinger · 7742 St. Georgen/Schwarzwald

united audio

United Audio Products, Inc., 120 So. Columbus Avenue, Mt. Vernon, N.Y. 10553
(914) 664-6211 TWX-710-562-0101

PLEASE NOTE FOLLOWING CORRECTIONS TO SERVICE MANUALS

MODEL 606

<u>Position</u>	<u>Incorrect Part #</u>	<u>Correct Part #</u>	<u>Description</u>
58	263339	263331	Spring housing cpl.

MODEL 622

48	264020	263262	Tonearm cpl.
109	263338	263388	Power plate compl

MODEL 626

103 Bracket fascia compl. agate-black Art.No.265628



Precision makes the difference in performance.