

Dual**622**

Edition January 1980

Service Manual



Technical Data

Current	AC 50 to 60 Hz
Line voltage	110 to 125 V, 220 to 240 V
Drive	electronically-controlled direct-drive system, Dual EDS 500
Power input	Motor at playing operation approximately 2 watts < 50 mW
Power consumption	220 V 50 Hz: at start 35 mA 110 V 60 Hz: at start 65 mA at play 15 mA at play approximately 25 mA
Time from start to rated speed	2 - 2.5 s at 33 1/3 rpm
Platter	non-magnetic, 1.4 kg, 304 mm diameter
Platter speed	33 1/3 and 45 rpm, electronically adjustable
Pitch control	Separate for both speeds, each adjustable by means of variable resistor, with calibration scale; range of regulation: 10 %
Speed control (monitoring)	with illuminated stroboscope for platter speeds 33 1/3 and 45 rpm, adjustable to 50 or 60 Hz
Sensitivity of the illuminated strobe (for 0.1 % speed deviation)	6 division markings per minute at 50 Hz, 7.2 division markings per minute at 60 Hz,
Total wow and flutter (according to DIN 45 507)	(German Industry Standard) ± 0.05 % WRMS ± 0.03 %
Rumble (according to DIN 45 500)	Unweighted: 50 dB Weighted: 75 dB
Tonearm	Torsionally rigid tubular aluminum tonearm in low-friction four-point gimbal suspension
Effective length of tonearm	221 mm
Offset angle	24° 4'
Tangential tracking error	0.16° /cm
Tonearm bearing friction (related to stylus tip)	vertical < 0.07 mN (0.007 g) horizontal < 0.15 mN (0.015 g)
Stylus pressure	from 0 to 30 mN (0 to 3 g) infinitely variable with 1 mN- (1/10 g) calibrations from 0 to 15 mN (0 to 1.5 g) operable from 2.5 mN (0.25 g) stylus pressure up, with 1/2 inch screw-type attachment. These can be fitted with the special accessories no. 262 186 which can be obtained from trade dealers.
Cartridges	ca. 5.4 kg Dimensions and Cutout Required refer to Installation Instructions.
Weight	

Contents

Page	
1	Technical data
2	Audio connection diagram
3	Wiring diagram
4	Dual EDS 500 electronic direct drive system
4	Replacement of motor electronic
4	Replacement of motor mechanic
4	Adjustment of nominal speeds
4	Setting 78 rpm nominal speed
5	Stroboscope
5	Pitch control
5	Tonearm and tonearm suspension
6	Removal of tonearm or spring housing
6	Removal of tonearm compl. with tonearm suspension
6	Adjustment of tonearm suspension
6	Fitting 1/2 inch pick-up
6	Antiskating control
7	Cue control
7	Replacement of cue control assembly
7	Tonearm Control
7	Muting Switch
8	Continuous Play
8	Start
8	Manuel Start
8	Stopping
9	Shutt-off Mechanism
9	Adjustment Points: Tonearm set Down Point
9	Shut off Point
9	Tonearm does not set down
9	Vertikal Tonearm lift
10	Correct nominal speed obtained only at extreme setting of pitch control
10	Platter does not start
10	Tonearm does not set down correctly
10	Motor does not shutt-off
10	Acoustic feedback
10 – 13	Replacement with exploded views
14	Lubrication

Fig. 1 Audi Connection Diagramm

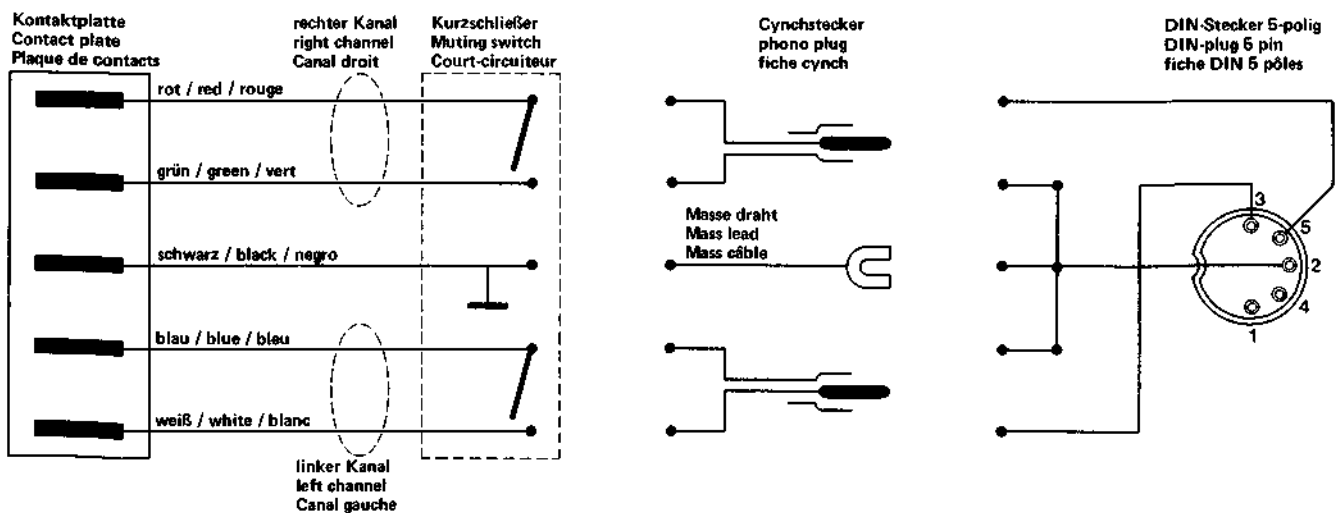

Fig. 3

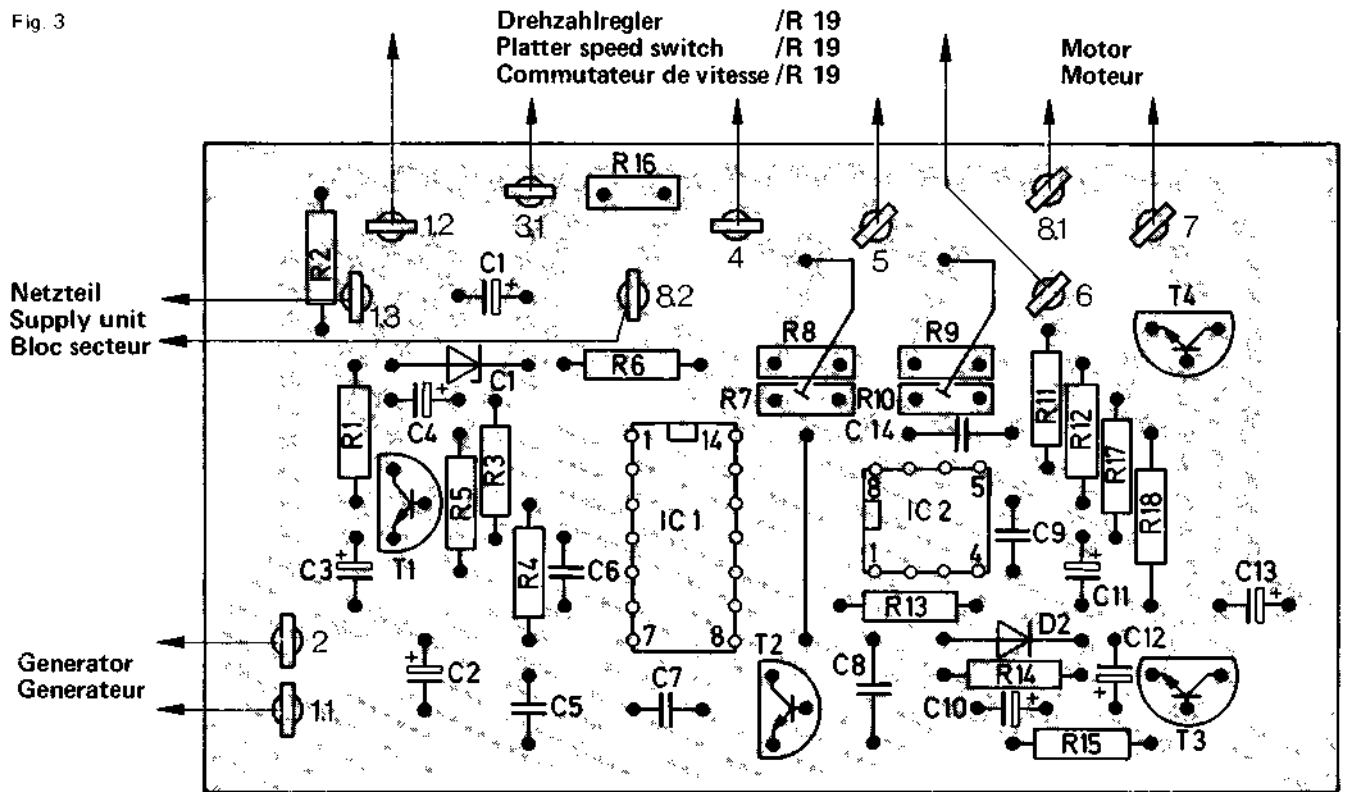

Fig. 4

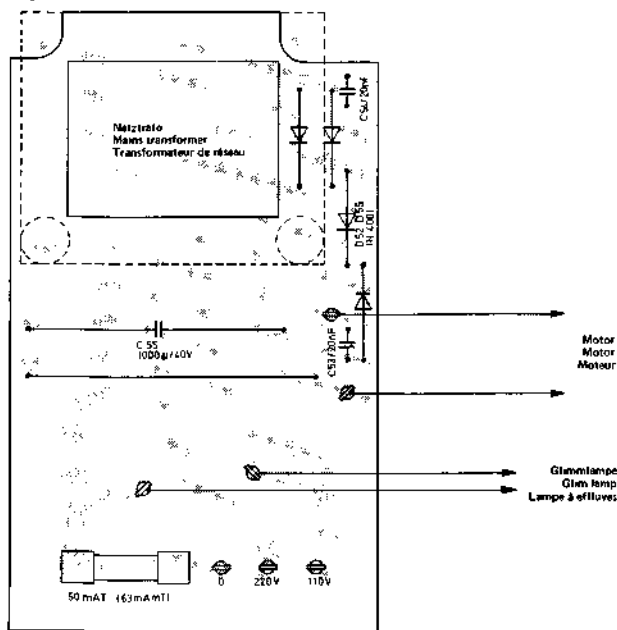
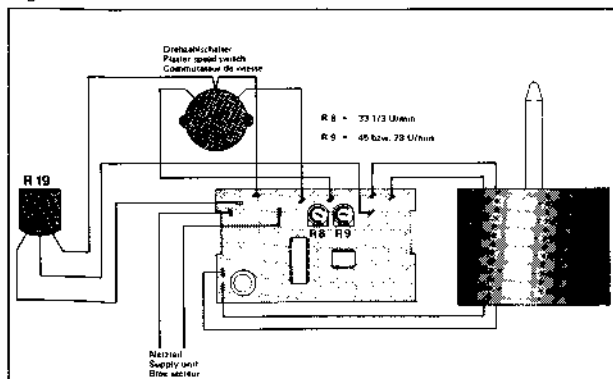

Fig. 5



Direct Drive System Dual EDS 500

For repair of the Dual EDS 500 special tools and measuring means are required. Work on the motor or motor electronics system should, therefore, only be carried out by an authorized Dual service station.

Replacement of motor electronics

1. Extract unit plug from power line. Lift off platter 4. Bring unit into head position.
 2. Remove machine screws 112 and cover of power part.
 3. Unsolder connecting leads to motor and generator. Open twists of holding angle 150 with pliers. Remove motor electronics 152, screws 151 and holding angle 150.
 4. Pull off motor electronics 152 system from motor 18 carefully.
 5. Fix replacement motor electronics. Solder connecting cables see connection diagram Fig. 5.
 6. Slide cover over power part and fix it by means of machine screws 112.
 7. With the unit in normal position connect it to power line. Switch on unit and check power consumption on operation:
220 V/50 Hz approx. 15 mA
110 V/60 Hz approx. 25 mA
- Check nominal speeds. If necessary, readjust as described below.

Replacement of motor mechanics

1. Extract unit plug from power line. Remove platter 4.
2. With the unit in head position remove machine screws 174 and washers 173. Pull off motor electronics board 172 together with cover 175 carefully from the motor 18.
3. Loosen connection for operating voltage at hot plate 109. Unsolder connecting leads to speed fine adjustment 129, rotary switch 5 and the generator. Open twists of holding angle 152 with pliers.

4. Loosen threaded pins **13** and remove platter cone **12**. Remove the three screws **148**. Lift off motor mechanics **149**.
5. Put platter cone **12** on new motor mechanics and fix it. Fix new motor mechanics with the three screws **148**. Fix holding angle **150** with screws **151**. Insert motor electronics **152** and twist holding pieces. Solder on resp. plug connecting leads (fig 5) Push cover on power part and fix it with screws **112**.
6. With the unit in normal position connect it to the power line Switch on unit and check power consumption when operating:
 - 220 V/50 Hz approx. 15 mA
 - 110 V/60 Hz approx. 25 mA
 Check nominal speeds. If necessary, readjust as described below.

Setting nominal speeds

With knob **7** bring the fine speed control **129/R 19** into center position. With controls **R 8** and **R 9** on the motor electronic system adjust nominal speeds. Control **R 8** is used for 33 1/3 rpm, **R 9** for 45 rpm. Check with strobe disk.

Changeover to 78 rpm nominal speed

Instead of 45 rpm the Dual 622 can be changed to a nominal speed of 78 rpm.

To change the speed bring the fine speed control **129/R 19** in center position using knob **7**. Using control **R 9** on the motor electronics board **152** adjust for 78 rpm. Check with strobe disk.

Stroboscope

Accurate setting of the platter speeds 33 1/3 and 45 rpm can be checked during play with the aid of the stroboscope.

When the platter **4** is rotating at exactly 33 1/3 or 45 rpm the lines of the stroboscope appear to stand still. If the lines move in the direction of rotation of the platter, the platter speed is too high. If the lines move backwards, the platter is rotating more slowly than the nominal speed. Adjustment of platter speeds 33 1/3 and 45 rpm is carried out separately with the "pitch" controls **7**.

Strobe markings are provided on the outer edge of the platter for 50 and 60 Hz line frequencies.

To replace glow lamp **157** remove machine screws **160** and remove strobe cover

It can happen that the stroboscope lines appear to move slightly although the exact speed setting with stroboscope stationary has not been altered. This apparent contradiction is explained by the fact that the electronic central drive motor operates fully independently of line frequency whilst the only relatively accurate line frequency of the AC current supply is used for speed measurement with the light stroboscope. The constantly detectable fluctuations of line frequency by $\pm 2\%$ according to the information of the electricity supply companies brief frequency fluctuations up to 1% are possible — only effect the stroboscope indication and can cause the lines to "wander" although the platter speed is as constant and absolutely accurate as before.

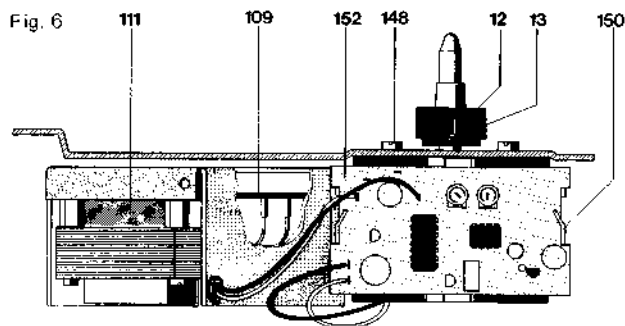

Pitch Control

Each of the two standard speeds 33 1/3 and 45 rpm (78 rpm) can be varied by about 10%. The variable speed control **129/R 19** located in the voltage divider is adjusted by turning the pitch control knob **7**. By this the differential amplifier is altered and the motor speed accordingly.

Fig. 7

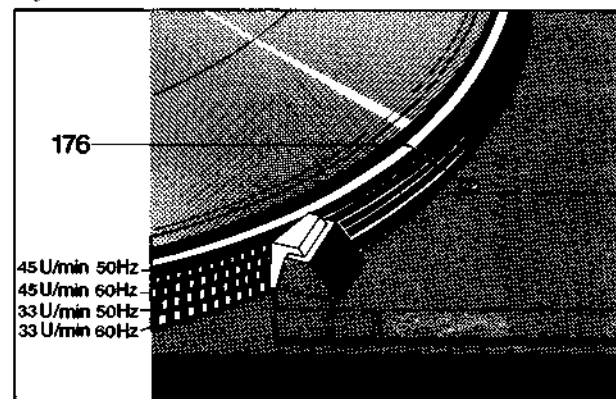

Tonearm and Tonearm Suspension

The feather-light, extremely torsion resistant all-metal tonearm is suspended in a gimbal. Suspension is by means of **4** hardened and precision polished steel points which rest in precision ball bearings. Tonearm bearing friction is thus reduced to a minimum.

Bearing friction vertical 0.07 mN (0.007 p)
 Bearing friction horizontal 0.15 mN (0.015 p)

as related to stylus point.

As a result, it ensures most favourable pick-up conditions. Before adjusting the tracking force to suit the built-in pick-up cartridge the tonearm is balanced with the scale set to zero. Coarse adjustment is carried out by moving the weight with the stem **49**, the subsequent fine adjustment by turning the weight.

The tracking force is adjusted by turning the graduated spring housing **58** incorporating a coil spring. The Rotary knob **54** has markings for a range of adjustment from 0 to 30 mN (0 to 3 p) which permit accurate adjustment of the tracking force. One graduation in the range of 2 – 15 mN (0.2 – 1.5 p) corresponds to 1 mN (0.1 p), in the range of 15 – 30 mN (1.5 – 3 p) to 2.5 mN (0.25 p).

Fig. 8

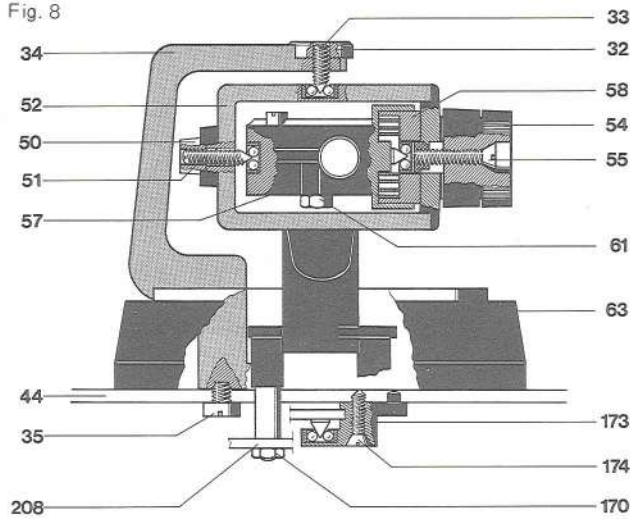

Fig. 9

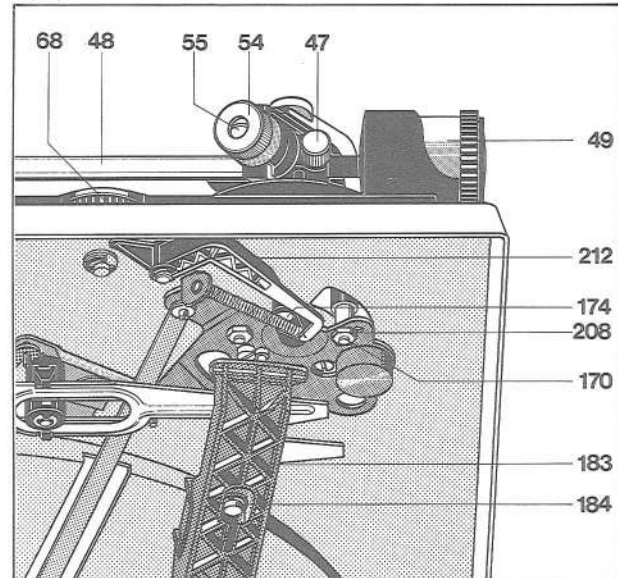
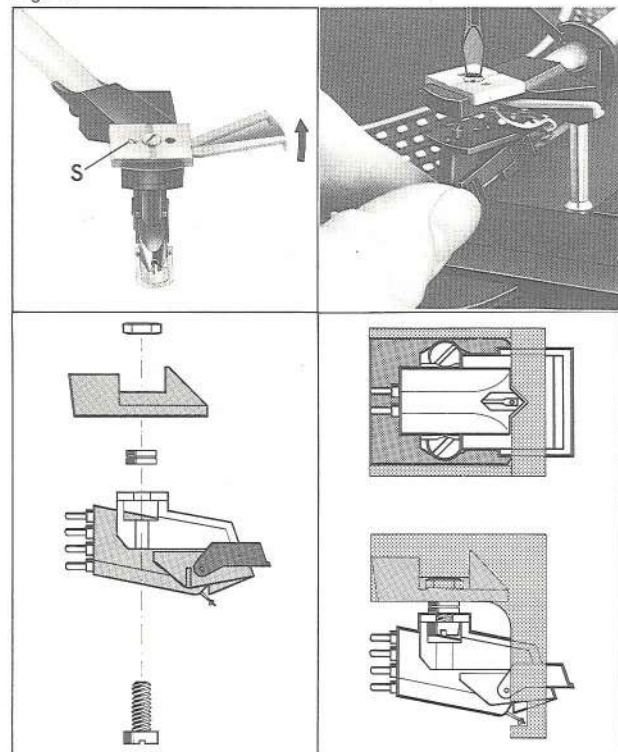

Fig. 10



To Remove the tonearm or the spring housing

1. Secure the unit in a repair stand. Turn the rotary turn switch **51** to the zero position. Lock the tonearm **48**. Remove the counterweight **49**.
2. Turn the unit over. Remove the screening sheet **140** and solder off the tonearm connections at the short circuiter **137**. Turn the unit the right way up.
3. Remove the fillister head screw **55**. Remove the rotary turn switch **54** and the washer **53**.
4. Loosen the nut **50** and the grub screw **51**. Draw the tonearm **48** complete with bearing **57** from the bearing race **52**. The spring housing **52** or the tonearm **48** may now be changed. Reassembly involves the reverse procedure.

Removal of tonearm assembly with tonearm bearing

We recommend the following procedure:

1. Clamp unit in the repair jig. Set the rotary knob **54** to zero. Lock tonearm **48**. Remove weight **49**.
2. Move unit into head position and remove the screening plate **140**. Unsolder the tonearm connections on the muting switch **137**.
3. Remove lock washer **184**. Lift off main lever **183** and bearing support **182**. Remove lock washer **144**. Lift off setting rail **141** and rotary bearing **143** and turn towards motor **149**.
4. Unlock tension spring **209**. Loosen lock washer **212** and remove skating lever **211**.
5. Remove lock washer **211** and slide bar **171**. Lift off shut-off bar **161** from segment **208**.
6. Remove hex nut **170**. Remove sink screw **174**. Hold tonearm **48** and lift off counter bearing **173** and segment **208**.
7. Remove tonearm complete with tonearm bearing.

Reverse this procedure when reassembling. Please bear in mind the threaded pin **33** is correctly positioned in the ball bearing.

Adjusting the tonearm bearing

First balance tonearm exactly. Both bearings must have slight, just perceptible play. The horizontal tonearm bearing is correctly adjusted when at anti-skating settings "0.5" and being touched it slides in without resistance. The vertical tonearm bearing is correctly adjusted when it swings in after being touched. The play of the horizontal tonearm bearing should be adjusted with threaded pin **33** and mat of the vertical tonearm bearing with threaded pin **51**.

Fitting a 1/2 inch cartridge

If a cartridge with 1/2 inch standard mount is to be fitted, the conversion kit **31** Number 262 186 is necessary. The proper method of fitting is shown in fig. 8. Also the decorative cover should be removed from the counterweight **49** and should be fitted with the compensatory weight to be found in the conversion kit **31**. Any alteration can only be carried out with the aid of a Dual-Skate-0-Meter and a test record and should only be done by an authorized service station.

Anti-skating Device

To compensate for skating force use the knurled ring **68**. The asymmetric cam plate displaces the skating lever **216** from the tonearm pivoting point. The anti-skating force is transmitted to the segment **207** and to the tonearm **48** by tension spring **208**. Optimum adjustment is carried out at the works for styli having a tip radius of 15 μm (conical), 5/6 and 18/22 μm (elliptical). Any alteration can only be carried out with the aid of a Dual-Skate-0-Meter and a test record and should only be done by an authorized service station.

Cue Control

By moving the lever **190** forward () lift cam **192** rotates. The slide bar **141** transmits the lifting movement to the lift pin **206**, that raises the tonearm. As a result, the cue control permits raise up the tonearm at any desired point.

The lever **190** is released by moving the cue control lever rearwards (). As a result of the action of compression spring **205** the lift pin **206** is brought back to its normal position and the tonearm lowers slowly. Lowering of the tonearm is damped by silicone oil in the lift tube.

Replacement of Cue Control Plate

Replace cue control plate **207** as follows:

1. Clamp unit in the repair jig and lock tonearm. Turn unit in head position.
2. Remove safety washer **184**. Lift off main lever **183** and bearing support **182**.
3. Remove safety washer **144**. Lift off positioning bar **141** and rotary bearing **143** and turn towards motor **149**
4. Remove both machine screws **204**, remove lift plate compl. **207**.

For installation proceed in the reverse order.

The lift can be varied by turning the sleeve **45**. The distance between the record and the needle should be 5 - 7 mm.

Fig. 11

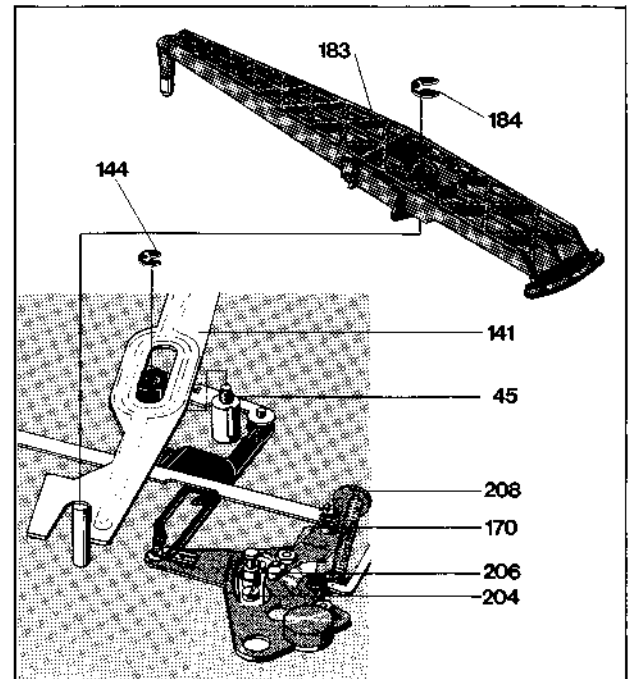
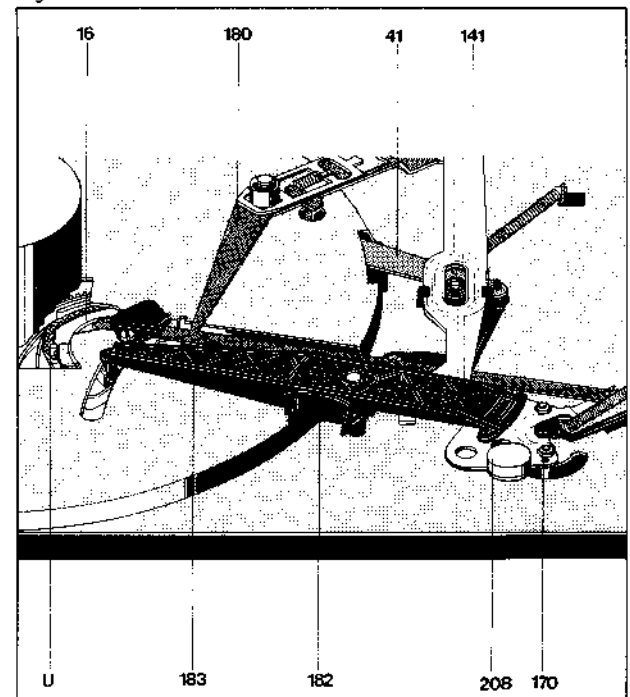

Fig. 12



Tonearm Control

Automatic movement of the tonearm is initiated by the control cams on the inside of the cam wheel **16** on rotating through 360°.

The control elements for raising and lowering are the main lever **183** and lifting bolt **206**, for horizontal movement the main lever **183** with segment **208**.

The automatic tonearm set down mechanism is designed for 30 cm and 17 cm records and is coupled to the platter speed change-over. The set down points of the tonearm are determined by the spring pin of segment **208** contacting the slide bar **141**. Limitation of the horizontal movement of the tonearm is produced by the pin of segment contacting the stop attached to the slide bar **189**. Only during set-down does main lever **183** lift the slide bar **141** and the stop attached to it which, as a result, moves into the swivel range of the stop pin fitted on this segment. After completion of set down (lowering of the tonearm onto the record) slide bar **141** is released again and returns to its neutral position. As a result, the slide bar **141** moves out of the swivel range of the pin, so that unimpeded movement of the tonearm is possible for playing.

Muting Switch

To prevent disturbing noises during automatic operation of the tonearm the unit is fitted with a muting switch. Control of the switch springs for both channels is effected by the camwheel. With the unit in neutral state the short circuit of the pick-up leads is eliminated.

Adjustment

In zero position of the cam there should be a clearance of approximately 0,5 mm between the contacts of the muting switch. This clearance should be adjusted by bending the muting switch contacts. The contacts should be sprayed with a suitable cleaning agent.

Fig. 13

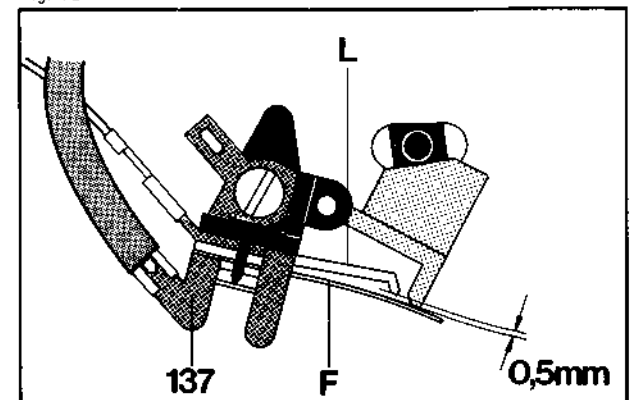
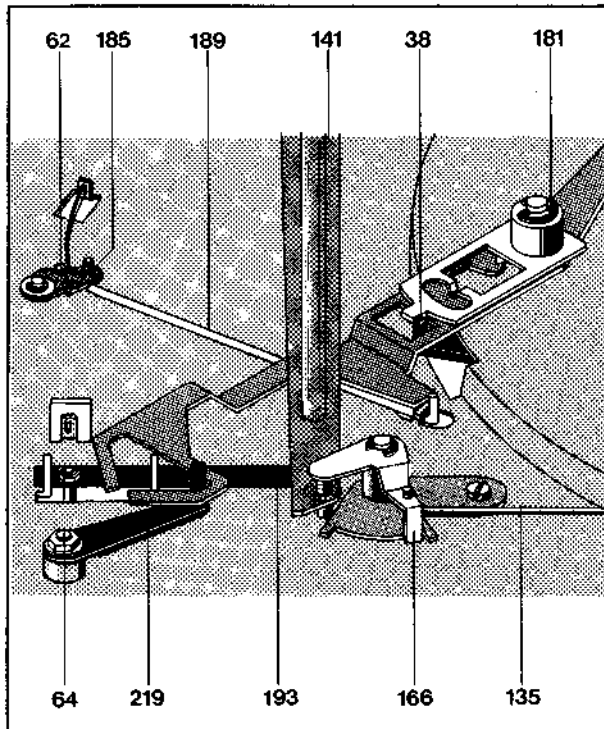

Fig. 14



Start

Switching the switch lever **64** into the "start" position initiates the following sequence:

- The start lever **219** rotates the switch lever **180** which is pivoted about the notched stud. At the same time, the switch arm **41** is moved the motor **149**, via the power switch **116**, and the platter starts turning.
- Operating the switch lever **68** also releases the start slide **38** which is drawn toward the cam by means of the tension spring **156**. By that the shut-off lever engage with the drive pinion and the cam turns.

Manual start

The latch **215** which is connected to the switch arm **41** engages in the four-sided plate when the tonearm is moved manually. The switch arm connects the mains supply to the motor **149** via the power switch **116** and the platter rotates. When the run-out groove of the record is reached, the tonearm is lifted and returned, the motor is switched off automatically. If the tonearm is lifted off the record before the run-out, and returned by hand to the pillar, then the bolt on the segment **208** engages the latch **215** so that the switch arm is returned to its starting position. This switches off the mains supply.

Continuous Play

Continuous Play is switched on by turning the rotary knob **62** to "∞". The rotary knob **67** turns the switch angle **185**. The switch rod **189** keep the change lever **180** in starting position. After the record has been played the tonearm returns automatically to the lead-in groove of the record. This procedure is repeated until the switch lever **68** is brought to the "stop" position or the rotary knob **62** to position "1".

Fig. 15

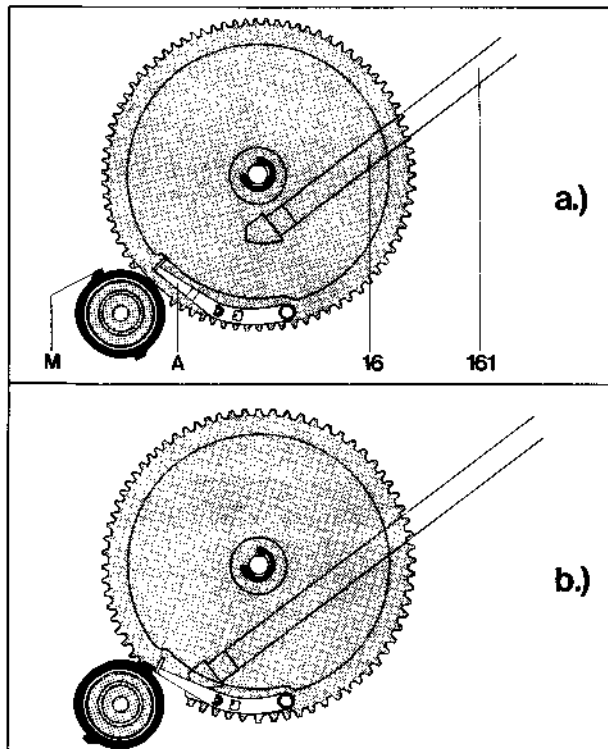

Adjustment Point

Pull mains plug. Remove platter **4**. Bring rotary knob **62** to position "∞". Turn cam wheel to central position. The change lever **180** turns the guide lever **U** and the top of the guide lever must at least be brought to the cam range. Adjust by bending the switch rod **189**.

Stopping

When control lever is set to "stop position" the start slide **38** which is pulled towards the cam by means of tension **34**, becomes free. As a result, the shut-off lever is moved into the range of dogs cam. The lever remains in its stop position.

Shut-off

The shut-off and stop functions depend on the position of the guide lever **U**. The guide lever **U** is brought to stop position by the main lever **183** after every start (longer end of the guide lever towards cam wheel centre). The shut-off bar **161** is guided along in proportion to the movement of the segment **208**. The shut-off procedure is imitated after a record has been played by the dog **M** of the platter and the shut-off lever **A**.

The shut-off lever **A** is moved towards the dog **M** of the platter within the shut-off range (record diameter 116 mm to 122 mm). The dog engages the shut-off lever **A**. The cam wheel **16** is moved from 0 position and engage with the drive pinion of the platter.
 The main lever **183** guides the tonearm back and effected the tonearm to return to its rest position. During the running in of the cam wheel into 0 position the roll **42** of the switch arm **41** can run into the cut-out provided at the cam wheel and achate the power switch **116**.

Adjustment Points

Tonearm set-down point

The set-down point can be varied with the eccentric bolt **176**. If the stylus sets down onto the record too far inside or outside turn eccentric bolt **176** in left or right direction (see Fig. 7).

Shut-off Point

The shut-off point (shut-off area of record diameter (116/122 mm)) can be varied with the eccentric **E** mounted on the segment **208**.

Tonearm lifting height

- Remove the mains plug. Guide the tonearm **48** towards the edge of the platter. The bottom edge of the cartridge housing should be parallel to the top edge of the platter cover. Carry out alignment by turning the adjusting sleeve **202**.
- Press the start button and turn the platter **4** in normal direction until the tonearm **48** reaches its highest position. The tonearm should now have a vertical play of approximately 1 – 2 mm (measured at the tonearm post). If necessary, slightly turn the adjusting sleeve **202**.

Power Switch

Turn in tonearm **48**. The slide **117** of the power switch **116** should have a play of 0.2 – 0.5 mm. Adjust by bending the switch arm **41**.

Fig. 16

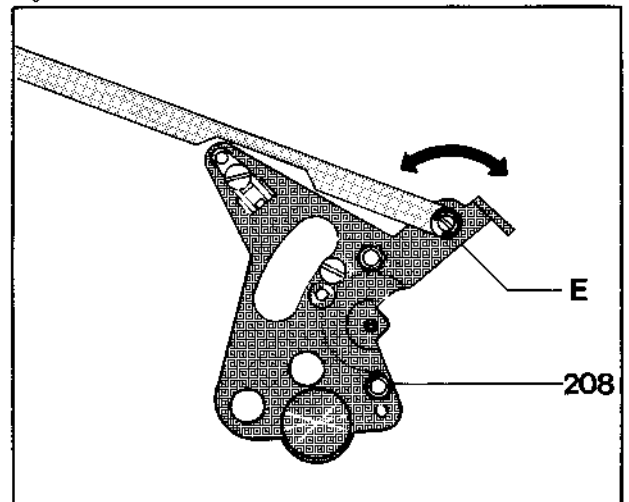

Fig. 17

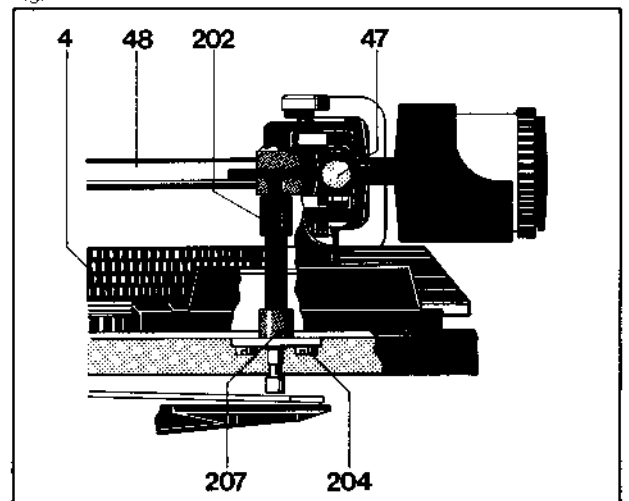
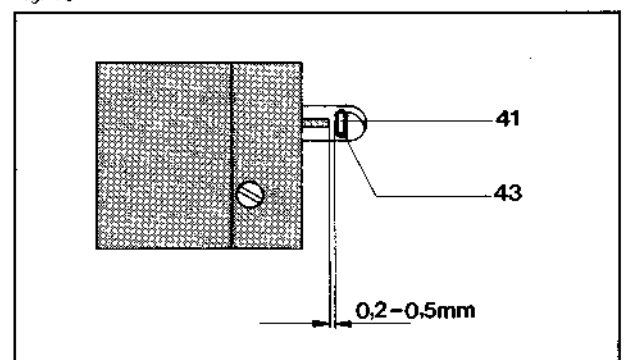

Fig. 18



Defect

Tonearm does not set down on record or lowers too quickly when operating the cue control lever **190**

Vertical tonearm movement shows resistance

Cause

Excessive or insufficient damping as a result of contamination of the silicone oil in the lift tube

Excessive friction of Lift Pin **205** in guide tube

Remedy

Remove cue control plate **207**. Remove shaft pin **200** and washer **201**. Remove adjustment bush sleeve **212**. Remove washer **203**. Remove lift pin **206** and compression spring **205**. Clean lift tube and lift pin. Smear lift pin evenly with "Wacker Silicon Oil AK 300 000". Reassemble components.

See above, if necessary change the lift pin **206**

Defect	Cause	Remedy
Speed lies at limit of the range of adjustment of the pitch control	Nominal speed is maladjusted.	Readjust nominal speed, described on page 7.
Platter does not turn after switching unit on and moving tonearm in side	Power supply to motor interrupted. Power fuse 110 defect	Replace the fuse 110
Tonearm does not set down at the lead-in groove of the record	Tonearm set-down point is incorrectly set	The tonearm set-down point can be adjust with the eccentric bolt 176
Motor does not switch off when tonearm set down on rest.	Suppressor capacitor in power switch ist faulty (short circuit).	Replace suppressor capacitor in power switch
Acoustic feedback	a) Chassis components (e.g. connecting leads) rubbing on board cut out b) Connecting leads too tight.	a) Line up mounting board cut-out according to installation instructions b) Slacken or lengthen leads.

Replacement parts

Pos.	Part.No.	Qty	Description	Pos.	Part.No.	Qty	Description
1	220 213	1	Centering piece	50	246 884	1	Counter nut
2	214 056	1	Washer	51	234 634	1	Grub screw
3	263 254	1	Platter compl. with mat	52	263 329	1	Bearing frame compl.
4	263 256	1	Platter compl.	53	261 798	1	Washer
5	238 034	1	Rotary switch	54	248 989	1	Rotary knob
6	260 335	1	Rotary knob	55	249 097	1	Raised counter sunk head screw
7	260 336	1	Rotary knob				M 2.5 x 12
8	242 191	3	Grub screw	56	236 069	1	Machine screw
9	263 257	1	Pitch cover	57	263 330	1	Bearing compl.
10	200 444	8	Spring washer	58	263 331	1	Spring housing compl.
11	239 414	3	Shipping screw compl.	59	248 979	1	Lifting plate
12	262 634	1	Washer	60	210 597	1	Washer
13	210 147	1	Lock washer	61	262 294	1	Hexagon sheet screw
14	242 192	1	Platter come compl.	62	260 334	1	Rotary knob
15	242 191	3	Grub screw	63	263 332	1	Rear cover compl.
16	246 035	1	Cam wheel	64	260 485	1	Switch lever
17	232 972	3	Spring mount compl.	65	260 328	1	Stroboscop prism
	237 228	1	Spring mount compl. (Tonearm side front)	66	263 333	1	Front cover
18	230 529	9	Threaded piece	67	263 334	1	Tonearm rest compl
19	230 521	3	Compression spring	68	260 320	1	Cam disc
	236 712	1	Compression spring (Tonearm side front)	69	242 298	1	Washer
20	200 723	4	Rubber damping	70	228 113	1	Washer
21	200 722	4	Steel cup	71	210 146	3	Lock washer
24	234 582	1	Tension spring	72	200 444	4	Spring washer
25	263 259	1	Tonearm head compl.	101	210 517	2	Machine screw
26	261 929	1	Tonearm lead compl.	102	210 648	2	Washer
31	262 186	1	1/2 inch conversion kit compl.	103	242 283	2	Bush
32	249 383	1	Counter nut	104	209 939	2	Sleeve
	262 695	1	Counter nut	105	210 480	4	Machine screw
33	234 651	1	Grub screw	106	237 548	2	Grommet with cord stopper
34	263 260	1	Frame compl.	107	228 209	1	Sleeving
35	242 677	1	Machine screw	108	242 284	1	Insulating plate
36	233 710	1	Tension spring	109	263 338	1	Power plate compl.
37	210 146	1	Lock washer	110	242 478	1	Fuse
38	242 786	1	Start slider				T 0.063 A
39	210 361	1	Hex nut	C 53	222 760	2	Ceramic
40	242 768	1	Bush	C 54	222 760	2	Ceramic
41	242 765	1	Switch lever	C 55	227 880	1	Elyt
42	242 785	1	Roll				20 nF/ 50 V
43	200 650	1	Rubber sleeve	D 52	227 344	4	
44	263 261	1	Mounting plate compl	D 53	227 344	4	
45	242 770	1	Adjustment screw	D 54	227 344	4	
47	260 428	1	Clamp screw	D 55	227 344	4	
48	264 020	1	Tonearm compl.				1 N 4001
49	263 263	1	Weight compl.	111	244 474	1	Power transformer
	263 328	1	Weight compl. (UAP)	112	210 283	2	Fillister screw
				116	242 581	1	Power switch compl.

Pos.	Part.No.	Qty	Description
117	236 335	1	Slider
118	200 444	1	Spring washer
119	233 012	1	Switch plate compl.
120	219 200	1	Snab spring
121	239 732	1	Tension spring
122	230 148	1	Switch angle
123	241 883	1	Capacitor 10 nF/250 V
	242 822	1	RF-cocke 47 μ H
124	242 102	1	Cover
125	210 498	1	Machine screw M 3 x 28
126	231 079	1	Cable holder
128	237 782	1	Nut for potentiometer
129	238 073	1	Speed control-potentiometer (R 19)
130	242 195	1	Contact piece
131	210 587	1	Washer 3.2/7/1
132	210 362	1	Hex nut BM 3
133	242 187	1	Contact assembly
134	210 469	1	Machine screw AM 3 x 3
135	242 741	1	Switch lever
136	242 790	1	Contact arm
137	242 612	1	Muting switch compl.
138	239 806	1	Base shet
139	210 486	1	Machine screw AM 3 x 8
140	242 791	1	Screening shut
141	242 769	1	Positioning slide
142	244 834	1	Compression spring
143	237 498	1	Rotary bearing
144	210 145	2	Lock washer 2.3
148	210 511	3	Machine screw AM 4 x 4
149	244 476	1	Motor mechanic
150	242 233	1	Upholder
151	210 511	1	Machine screw AM 4 x 4
152	244 477	1	Motor electronic compl.
157	260 421	1	Glim lamp
158	249 022	1	Glim plate
159	263 336	1	Stroboscope housing
160	210 469	2	Machine screw AM 3 x 3
161	242 763	1	Shut-off lever
162	209 357	1	Ball
163	232 104	1	Ball bearing
164	210 472	1	Machine screw AM 3 x 4
165	243 706	1	Ball spring
166	242 771	1	Rotary plate
167	210 146	8	Lock washer 3.2
168	223 777	1	Control stud
170	210 362	2	Hex nut
171	201 187	1	Washer
172	210 145	3	Lock washer
173	242 615	1	Bearing
174	203 475	1	Sunk screw M 3 x 8
175	242 792	1	Tension spring
176	242 751	1	Excenter pin
177	242 748	1	Plate
178	210 472	1	Machine screw AM 3 x 4
179	239 444	1	Tension spring
180	242 775	1	Changeover lever
181	210 146	8	Lock washer 3.2
182	242 789	1	Bearing
183	246 042	1	Main lever compl
184	210 147	4	Lock washer 4
185	237 382	1	Switch angle
186	237 383	1	Spring
187	210 549	1	Washer 2.1/5/0.5
188	210 353	1	Hex nut BM 2
189	242 774	1	Switch slide
190	247 509	1	Lever compl.
191	237 543	1	Rubber sleeve
192	242 742	1	Curve
193	210 353	1	Hex nut BM 2
200	216 844	1	Control stud
201	210 143	2	Lock washer 1.5
202	218 318	1	Adjusting sleeve
203	210 143	2	Lock washer 1.5

Pos.	Part.No.	Qty	Description
204	210 472	2	Machine screw AM 3 x 4
205	234 798	1	Compression spring
206	242 753	1	Lift pin
207	246 043	1	Lift plate
208	263 335	1	Segment
209	218 591	1	Tension spring
210	201 184	1	Adjustment disc
212	244 331	1	Scating lever compl.
213	210 146	8	Lock washer 3.2
215	242 764	1	Pawl
216	239 915	1	Square plate
217	210 472	1	Machine screw AM 3 x 4
218	218 154	1	Tension spring
219	242 747	1	Switch lever
220	210 600	1	Washer 3.2/8/1
221	210 361	2	Hex nut
230	209 424	1	Spole plug
231	207 303	1	Audio cable compl
232	207 301	1	Audio cable compl. with cynch plugs
233	209 436	3	Flat connector sleeve
234	209 425	1	Cynch plug white
235	209 426	1	Cynch plug black
236	214 602	2	AMP plug
237	232 996	1	Power cable Europa compl.
238	232 995	1	Power cable America compl
	261 952	1	CK 28 walnut console compl
	261 953	1	CK 28 agate-black console compl.
	261 954	1	CK 28 agate-brown
	227 986	1	CH 6 Cover compl.
	260 515	1	Operating Instructions
	261 756	1	Operating Instructions UAP
	260 359	1	Shipping carton CS
Motorelectronic			
C 1	220 766	4	Elyt 47 μ F/ 25 V
C 2	224 597	1	Elyt 220 μ F/ 6 V
C 3	216 410	3	Elyt 470 μ F/ 35 V
C 4	216 410	3	Elyt ⁻ 470 nF/ 35 V/10 %
C 5	227 963	1	Ceramic 10 nF/ 30 V/20 %
C 6	227 390	2	Ceramic 1 nF/ 63 V/20 %
C 7	227 390	2	Ceramic 1 nF/ 63 V/20 %
C 8	202 499	1	Foil 0.22 μ F/100 V/ 5 %
C 9	222 760	1	Ceramic 20 nF/ 50 V
C 10	216 410	3	Elyt 470 nF/ 35 V/10 %
C 11	235 573	1	Elyt 10 μ F/ 16 V
C 12	242 314	1	Elyt 0.68 μ F/ 35 V
C 13	220 766	4	Elyt 47 μ F/ 25 V
C 14	226 459	1	Foil 0.1 μ F/100 V/ 5 %
D 1	227 360	1	ZPD 7.5
D 2	223 906	1	I N 4148
R 1	224 603	3	1 M Ω /0.25 W/5 %
R 2	211 202	4	10 k Ω /0.25 W/5 %
R 3	224 735	1	68 k Ω /0.25 W/5 %
R 4	239 387	1	22 k Ω /0.25 W/5 %
R 5	224 603	3	1 M Ω /0.25 W/5 %
R 6	241 342	1	82 k Ω /0.25 W/5 %
R 7	242 307	1	47 k Ω /0.125 W/5 %
R 8	243 616	1	Potentiometer 10 k Ω
R 9	243 617	1	Potentiometer 22 k Ω / lin.
R 10	245 531	1	24 k Ω
R 11	227 384	1	110 k Ω /0.25 W/5 %
R 12	228 265	1	270 k Ω /0.25 W/5 %
R 13	239 395	1	15 k Ω /0.25 W/5 %
R 14	224 590	1	220 k Ω /0.25 W/5 %
R 15	211 202	4	10 k Ω /0.25 W/5 %
R 16	217 868	1	560 Ω /0.3 W/5 %
R 17	239 367	1	47 k Ω /0.25 W/5 %
R 18	242 311	1	2 Ω /25 W/5 %
T 1	229 511	2	BC 172 B
T 2	229 511	2	BC 172 B
T 3	244 715	1	BC 238 C
T 4	242 306	1	(NSD 102) BD 415
IC 1	242 303	1	NS 4069
IC 2	242 304	1	NS 555

Modification reserved!

Fig. 19 Exploded view 1

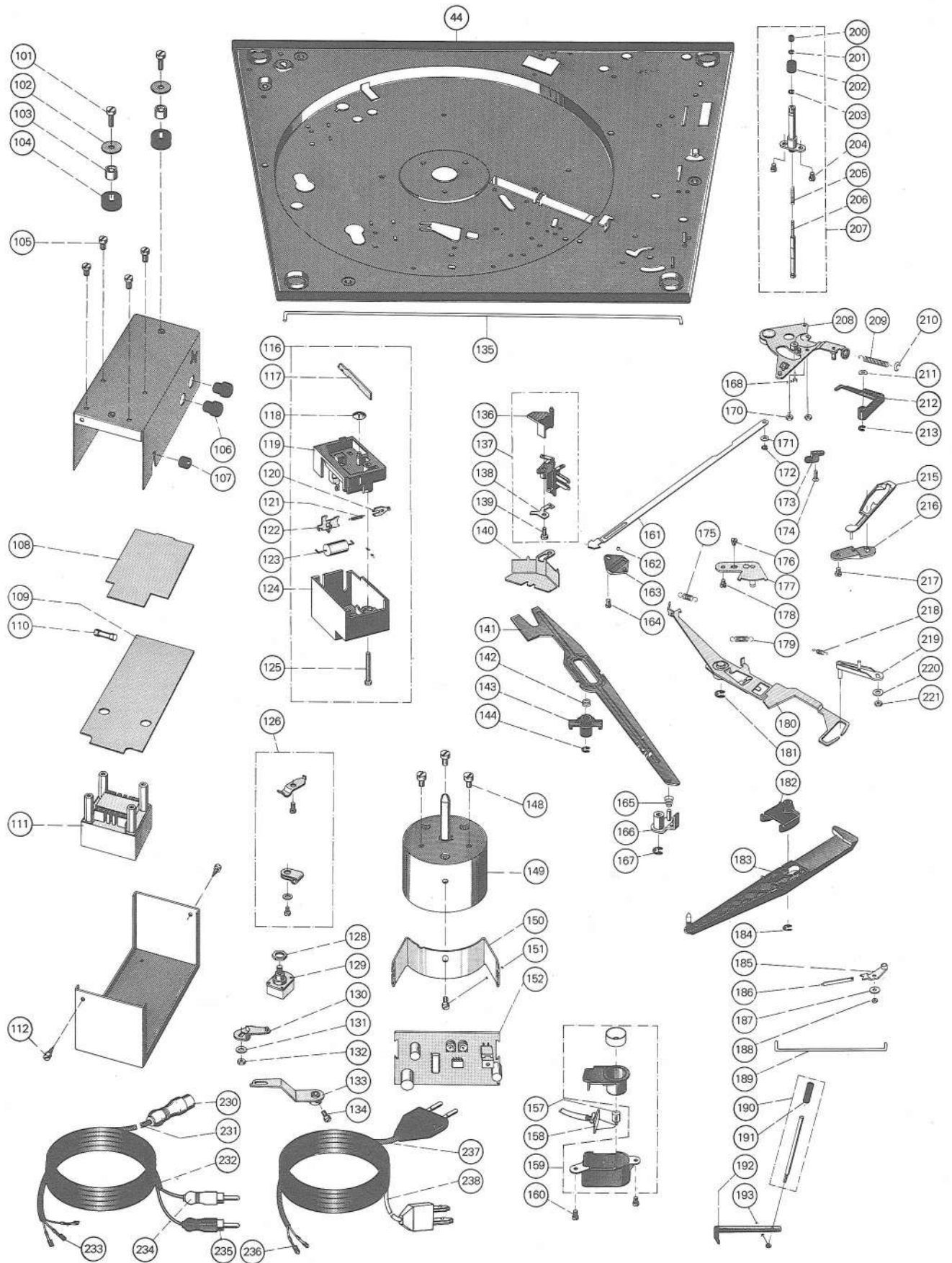
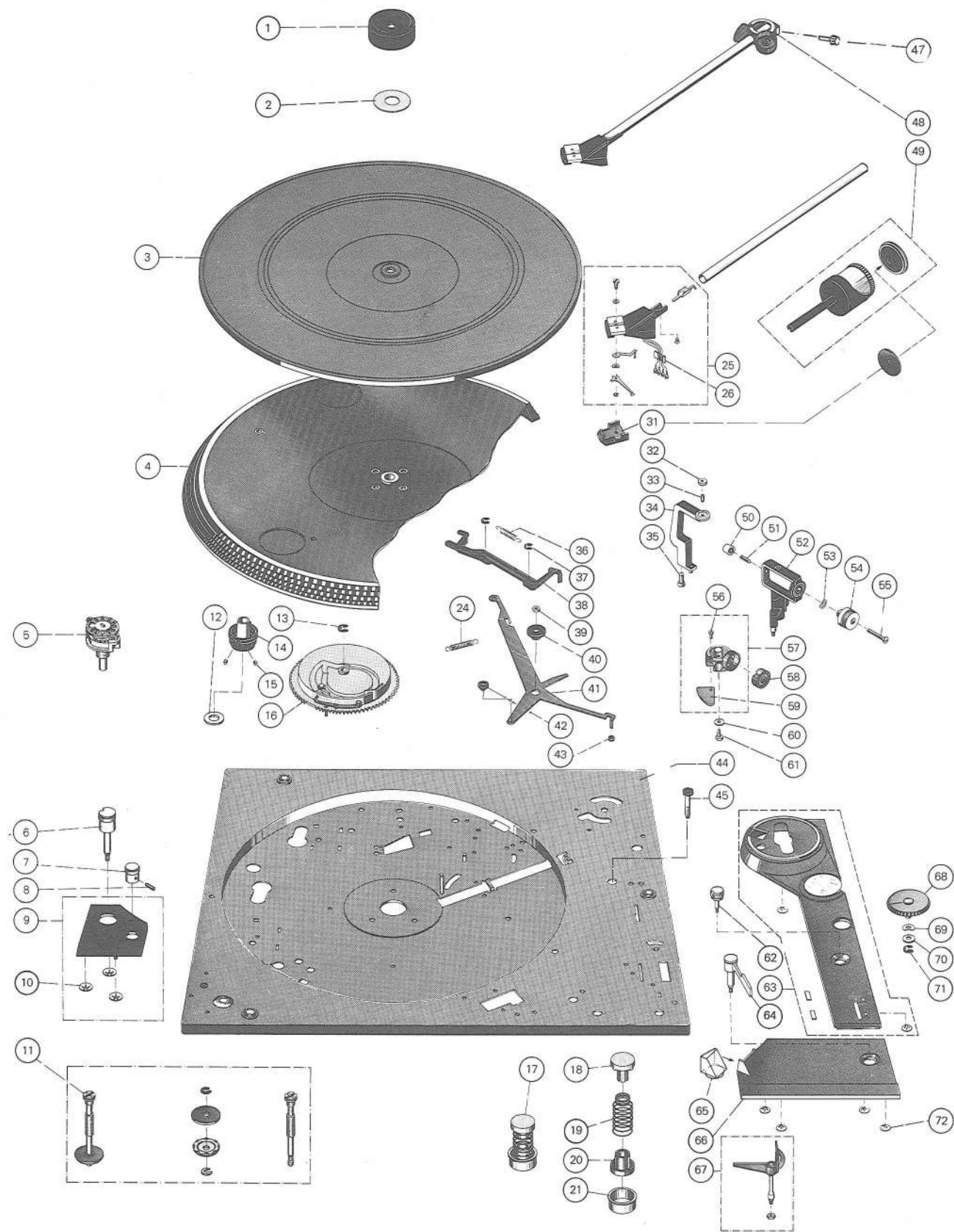

Fig. 20 Exploded view 2



Lubricating instructions

All bearing and friction points of the unit are adequately lubricated at the factory. Replenishment of oil and grease is only necessary after approx. 2 years of normal use as the most important bearing points have sintered metal bushes. The motor bearings have long-life sintered metal bushings and thus should not be lubricated. Bearing points and friction faces should be lubricated sparingly rather than generously. When using different lubricants, chemical decomposition can often take place. To prevent lubrication failure, we recommend using the original lubricants shown below.

- 1** Wacker silicon oil AK 300 000
- 3** BP super viscostatic 10 W/40
- 4** Shell alvania No. 2

Fig. 21

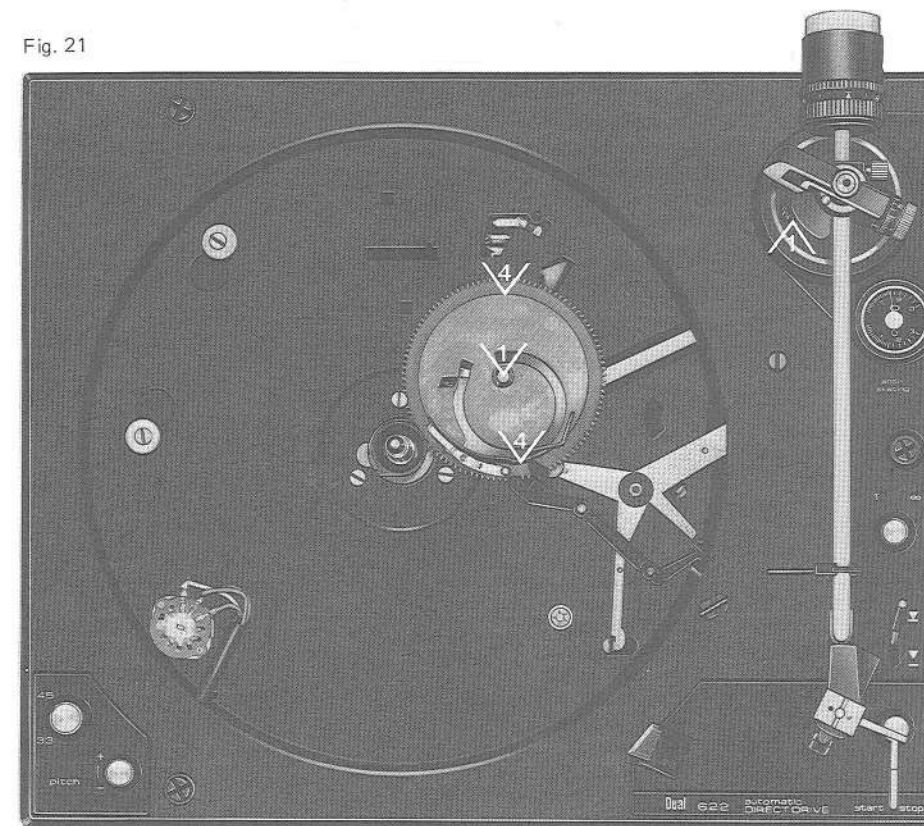
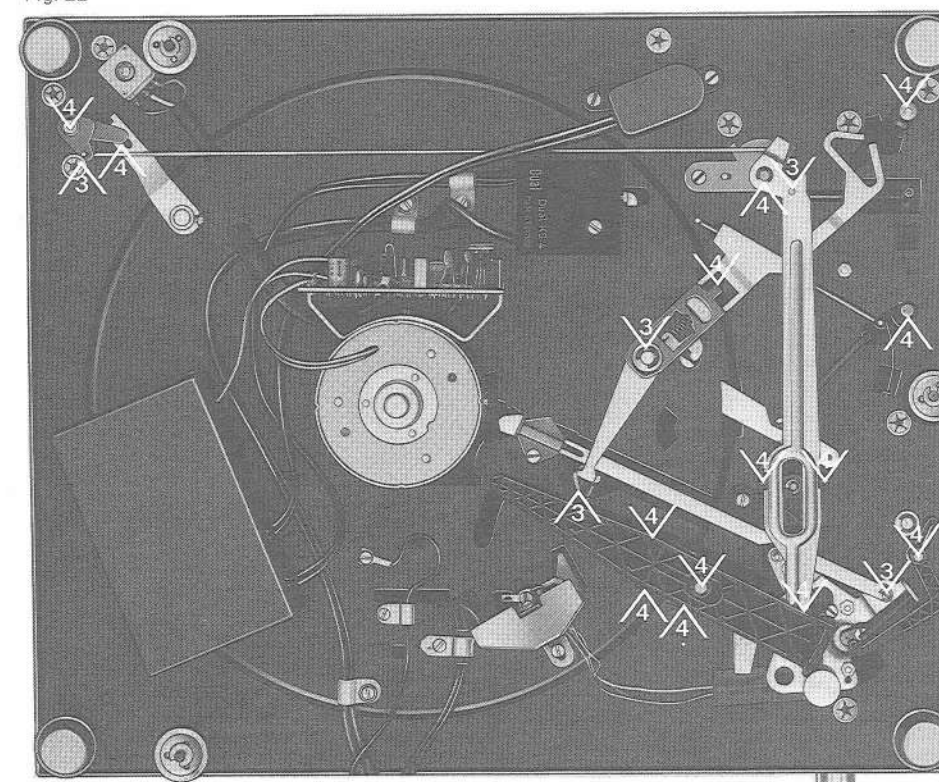

Fig. 22



Dual Gebrüder Steidinger · 7742 St. Georgen/Schwarzwald

920653-2 5.2/0180

Printed in Germany by Dual