

SERVICE MANUAL

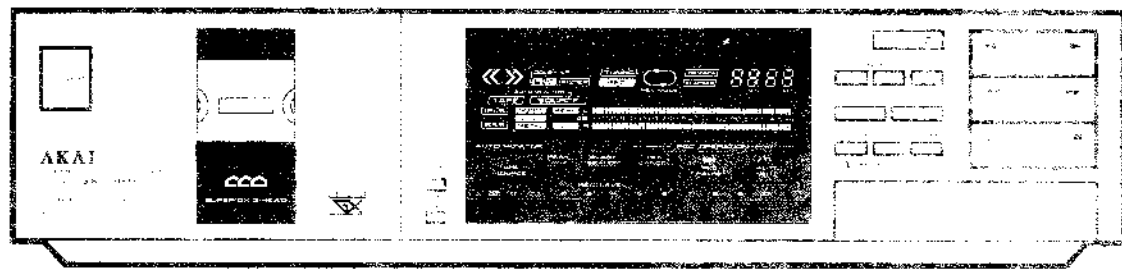

STEREO CASSETTE DECK

MODEL **GX-R88**

ABBREVIATIONS FOR SERVICE MANUAL MODEL GX-R88

Abbreviation	Explanation	Abbreviation	Explanation
AC	Alternating Current	MICOM	MicroCOMputer
A/D	Analog/Digital	MIN	MINute
AF	Auto Fader	MPX	Multi PleX
AM	Auto Monitor	NC	Not Connected (No Connection)
AMP	AMPLifier	NFB	Negative Feed Back
AR	Anti Recording	NORM	NORMAL
BEF	Band Elimination Filter	NR	Noise Reduction
BSS	Blank Search System	OSC	OSCillator (SOCillation)
CH	CHannel	P	Pulse
CN	Cam Normal	P.B.	Play Back
COMP	COMParator	QMSS	Quick Memory Search System
CR	Cam Reverse	R	Right
CS	Cam Stop	REC	RECORD (RECORDing)
D/A	Digital/Analog	REV	REVERSE
DC	Direct Current	ROT	ROTation
DET	DETECTOR	REW	REWind
DISCRI	DISCRIminator	SEC	SECONd
EQ	EQUALizer	SELE	SELEctor
FF	Fast Forward	SENS	SENSitivity
FLD	FLUorescent Display	SEPP	Single Ended Push Pull
FREQ	FREQUENCY	SIG	SIGNAL
FWD	FORWARD	SPECT	SPECTrum
GND	GROUNd	STD	STANdard
H	High	SW	SWitch
HPF	High Pass Filter	SYSCON	SYStem CONTRol
IND	INDicator	TP	Test Point
IPLS	Instant Program Location System	VOL	VOLUME
L	Low	VOLT	VOLTage
LED	Light Emitting Diode	VR	Variable Resistor
M	Motor	X'TAL	crystal

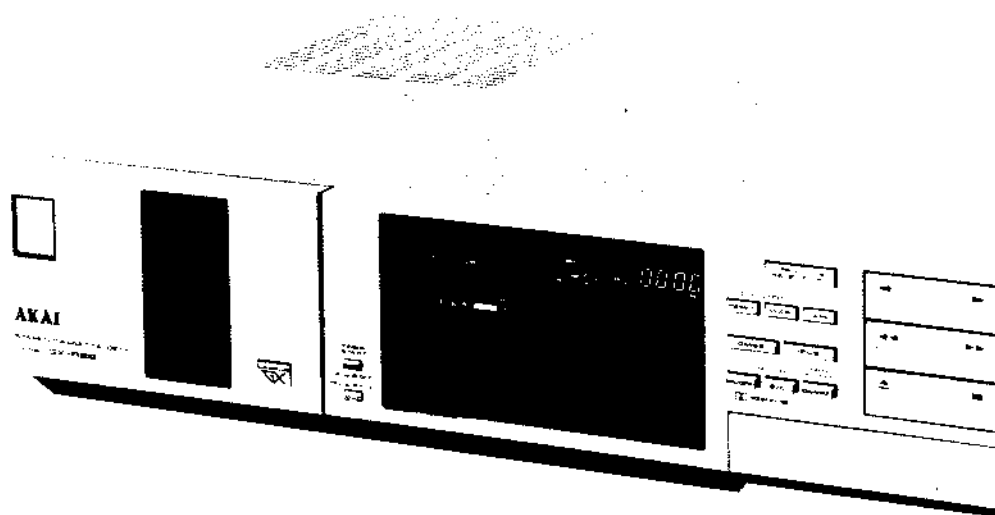

STEREO CASSETTE DECK

MODEL GX-R88

SECTION 1	SERVICE MANUAL	3
SECTION 2	PARTS LIST	23

SAFETY INSTRUCTIONS

SAFETY CHECK AFTER SERVICING

Confirm the specified insulation resistance between power cord plug prongs and externally exposed parts of the set is greater than 10 Mohms, but for equipment with external antenna terminals (tuner, receiver, etc.) and is intended for [C] or [A], specified insulation resistance should be more than 2.2 Mohms (ground terminals, microphone jacks, headphone jacks, line-in-out jacks etc.)

PRECAUTIONS DURING SERVICING

1. Parts identified by the Δ symbol parts are critical for safety.
Replace only with parts number specified.
2. In addition to safety, other parts and assemblies are specified for conformance with such regulations as those applying to spurious radiation. These must also be replaced only with specified replacements.
Examples: RF converters, tuner units, antenna selector switches, RF cables, noise blocking capacitors, noise blocking filters, etc.
3. Use specified internal wiring. Note especially:
 - 1) Wires covered with PVC tubing
 - 2) Double insulated wires
 - 3) High voltage leads
4. Use specified insulating materials for hazardous live parts. Note especially:
 - 1) Insulation Tape
 - 2) PVC tubing
 - 3) Spacers (Insulating Barriers)
 - 4) Insulation sheets for transistors
 - 5) Plastic screws for fixing microswitch (especially in turntable)
5. When replacing AC primary side components (transformers, power cords, noise blocking capacitors, etc.), wrap ends of wires securely about the terminals before soldering.

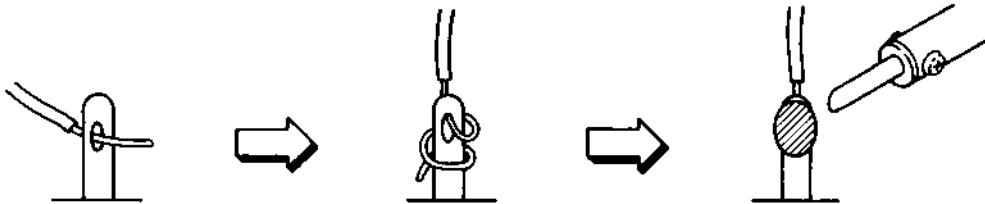

6. Observe that wires do not contact heat producing parts (heatsinks, oxide metal film resistors, fusible resistors, etc.).
7. Check that replaced wires do not contact sharp edged or pointed parts.
8. Also check areas surrounding repaired locations.
9. Use care that foreign objects (screws, solder droplets, etc.) do not remain inside the set.

VOLTAGE CONVERSION

Models for Japan, Canada, USA, Europe, UK and Australia are not equipped with this facility. Each machine is preset at the factory according to destination, but some machines can be set to 110V, 120V, 220V or 240V as required. If your machine's voltage can be converted:

1. Disconnect the power cord.
2. Turn the voltage selector located on the Rear panel with a screwdriver until the correct voltage is indicated.

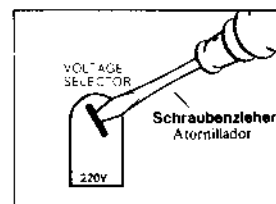

CYCLE CONVERSION

With DC MOTOR, CYCLE CONVERSION is not necessary.

SECTION 1

SERVICE MANUAL

TABLE CNTENTS

I.	SPECIFICATIONS	4
II.	DISMANTLING OF UNIT	5
III.	CONTROLS	6
IV.	PRINCIPAL PARTS LOCATION	7
V.	MECHANICAL ADJUSTMENT	9
	5-1 PINCH ROLLER PRESSURE MEASUREMENT	9
	5-2 WINDING TORQUE MEASUREMENT IN EACH MODE	9
	5-3 HOW TO INSTALL VOLUME (VR901) AND CAM WHEEL	10
	5-4 POTENTIO METER PRESET VOLTAGE ADJUSTMENT	11
	5-5 TAPE SPEED ADJUSTMENT	13
VI.	HEAD ADJUSTMENT	14
	6-1 TAPE GUIDE HEIGHT ADJUSTMENT	14
	6-2 REC/PB HEAD AZIMUTH ADJUSTMENT	15
	6-3 HEAD HEIGHT ADJUSTMENT	15
	6-4 HEAD BLOCK PROJECTION ADJUSTMENT	15
VII.	ELECTRICAL ADJUSTMENT	16
	7-1 PRE-AMPLIFIER P.C BOARD ADJUSTMENT	16
	7-2 TUNING ADJUSTMENT POINT	18
	7-3 QUICK REVERSE SENSITIVITY ADJUSTMENT	20
VIII.	DC RESISTANCE OF HEADS	21
IX.	P.C BOARD TITLES AND IDENTIFICATION NUMBERS	22

For basic adjustments, measuring methods, and operating principles, refer to GENERAL TECHNICAL MANUAL.

I. SPECIFICATIONS

TRACK SYSTEM	4 Track 2 channel Stereo System
TAPE	Philips Type Cassette
HEADS	Erase Heads × 2 Super GX Head for recording × 1 Super GX Head for playback × 1
MOTORS	FG Servo D.D. motor for direct capstan drive × 2 DC motor for reel drive × 1 DC motor for mecha drive × 1
WOW & FLUTTER	0.08% WTD (DIN) 0.028% W.RMS ±0.055% W.Peak (EIAJ)
TAPE WINDING TIME	90 sec. Using a C-60 cassette tape
FREQUENCY RESPONSE	Normal: 20 to 18,000 Hz ± 3 dB (EIAJ) CrO ₂ : 20 to 19,000 Hz ± 3 dB (EIAJ) Metal: 20 to 21,000 Hz ± 3 dB (EIAJ)
S/N RATIO	60 dB (Measured Via tape with peak recording level, Metal Tape) 56 dB (EIAJ): Metal Dolby B-type NR switch ON: Improves up to 5 dB at 1 kHz, 10 dB above 5 kHz Dolby C-type NR switch ON: Improves up to 15 dB at 500 Hz 20 dB at 1 kHz to 10 kHz
HARMONIC DISTORTION	1 kHz, 3rd Harmonic distortion Metal: 0.5% (EIAJ)
INPUT	Line 70 mV (Input Impedance: 47 kohms)
OUTPUT	Line 410 mV at 0VU Required load impedance: 250 ohms Phone: 1.3 mW/8 ohms at 0VU
POWER REQUIREMENTS	100V, 50/60 Hz for Japan 120V, 60 Hz for USA and Canada 220V, 50 Hz for Europe except UK 240V, 50 Hz for UK and Australia 110V/120V/220V/240V, 50/60 Hz switchable for other countries.
POWER CONSUMPTION	J model: 34W
DIMENSIONS	440 (W) × 105 (H) × 372 (D) mm (EIAJ)
WEIGHT	7.6 kg

* For improvement purposes, specification and design are subject to change without notice.

* Noise reduction manufactured under license from Dolby Laboratories Licensing Corporation. "Dolby" and the double-D symbol are trade marks of Dolby Laboratories Licensing corporation.

II. DISMANTLING OF UNIT

In case of trouble, etc. necessitating dismantling, please dismantle in the order shown in the photographs. Reassemble in reverse order.

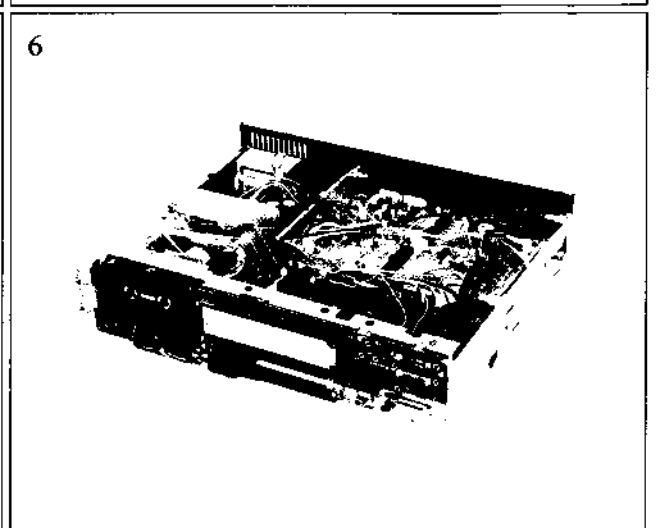
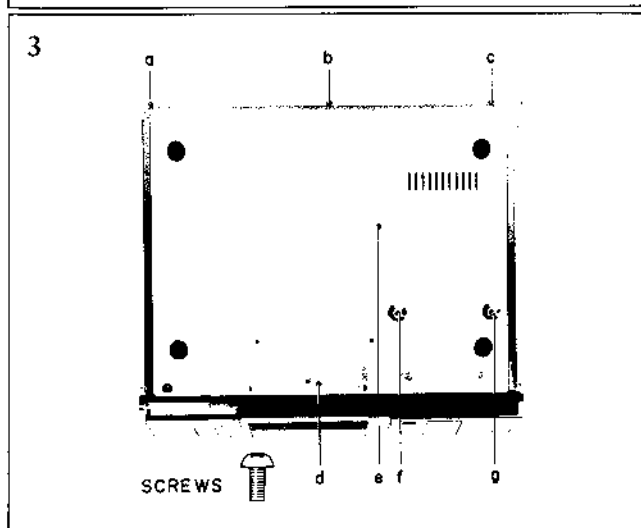
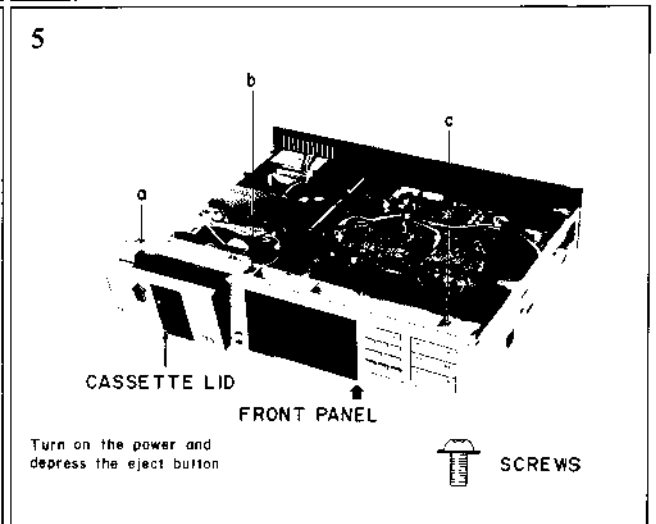
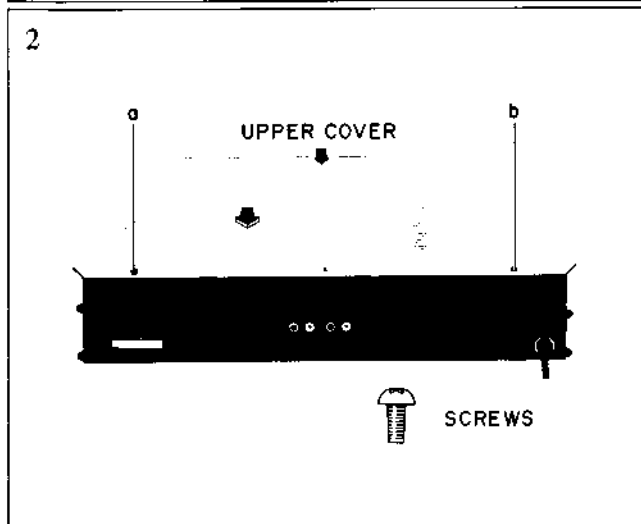
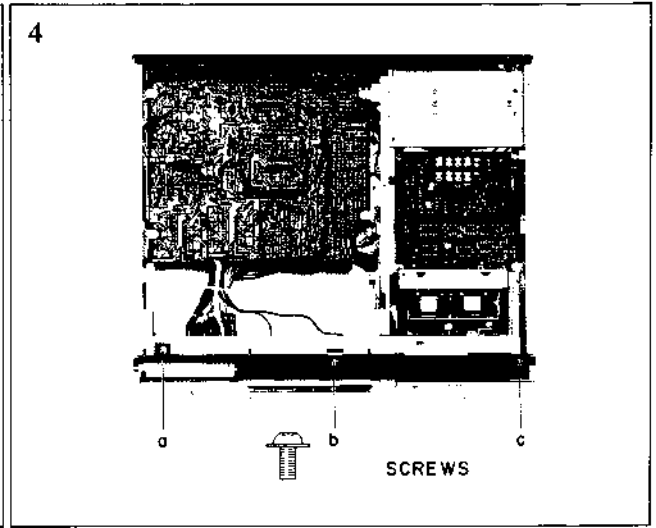
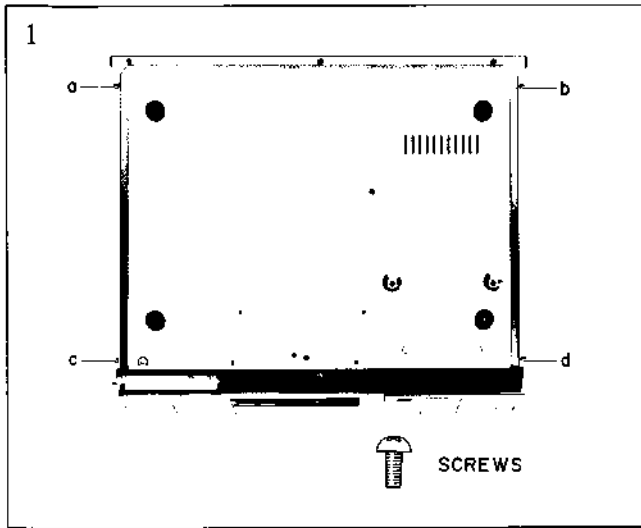

III. CONTROLS

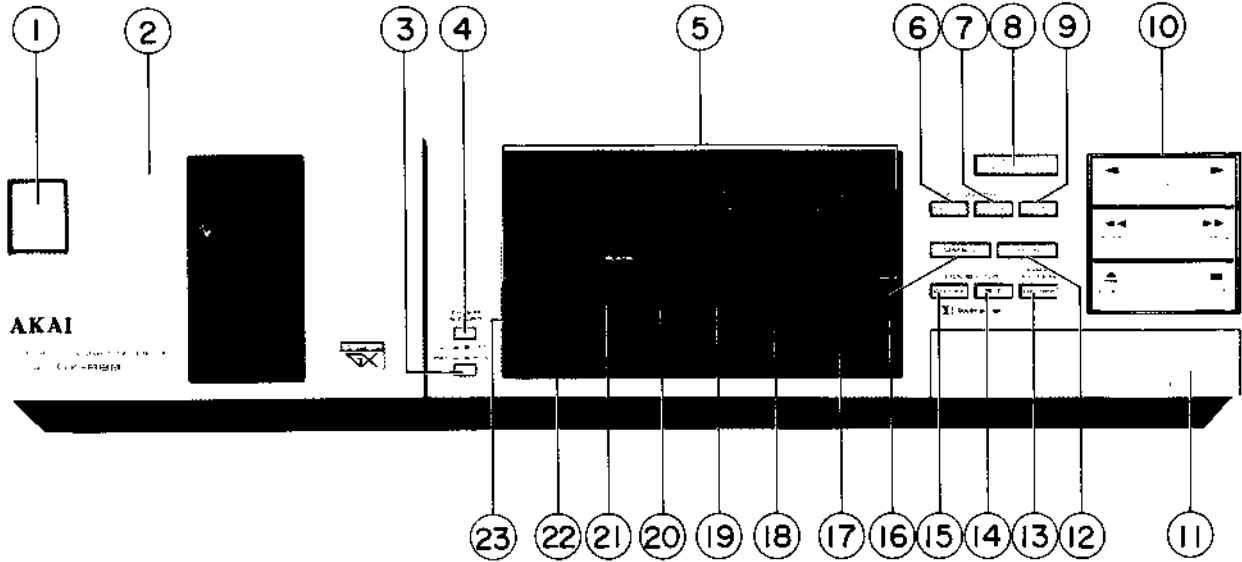

Fig. 3-1 Front View

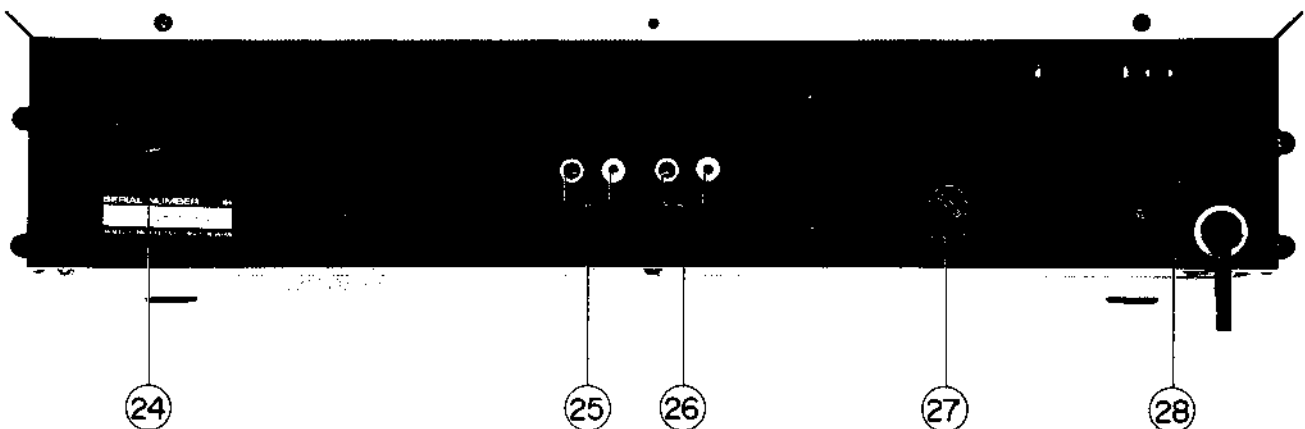

Fig. 3-2 Rear View

- | | |
|--|-------------------------------------|
| 1. POWER BUTTON | 13. MPX FILTER ON/OFF BUTTON |
| 2. CASSETTE LID | 14. DOLBY NR B/C BUTTON |
| 3. TIMER REC/PB BUTTON | 15. DOLBY NR ON/OFF BUTTON |
| 4. TIMER ON/OFF BUTTON | 16. QMSS BUTTON |
| 5. FL DISPLAY | 17. AUTO MUTE BUTTON (●) |
| 6. COUNTER RESET BUTTON | 18. REC/PAUSE BUTTON (●) |
| 7. COUNTER MODE BUTTON
(ELAPSED, REMAIN, COUNTER) | 19. REC CANCEL BUTTON |
| 8. REV SELECTOR BUTTON | 20. BLANK SEARCH BUTTON |
| 9. TAPE BUTTON
(C90, C60, C46, & LC46) | 21. PEAK/VU BUTTON |
| 10. OPERATION BUTTONS
FWD (▶) REV (◀) F.F (▶▶)
REW (◀◀) STOP (■) EJECT (▲) | 22. REC LEVEL VOLUME |
| 11. HEADPHONE & OUTPUT CONTROL | 23. TAPE/SOURCE MONITOR BUTTON |
| 12. IPLS BUTTON | 24. REMOTE CONTROL JACK |
| | 25. LINE IN (L/R) PIN JACK |
| | 26. LINE OUT (L/R) PIN JACK |
| | 27. VOLTAGE SELECTOR (U model only) |
| | 28. AC POWER CORD |

IV. PRINCIPAL PARTS LOCATION

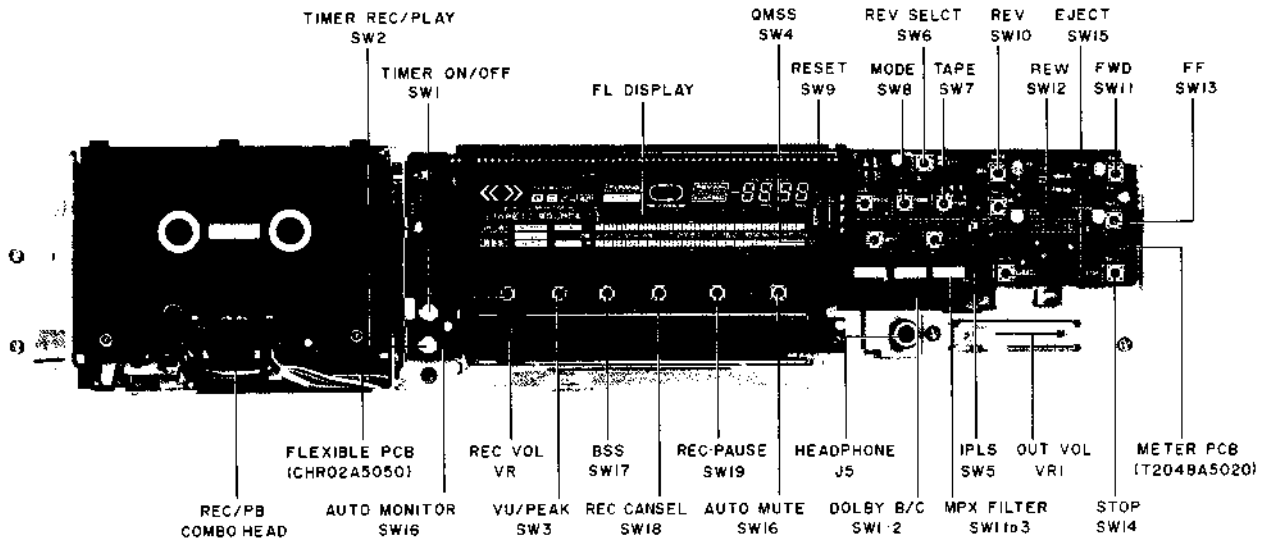

Fig. 4-1 Front View

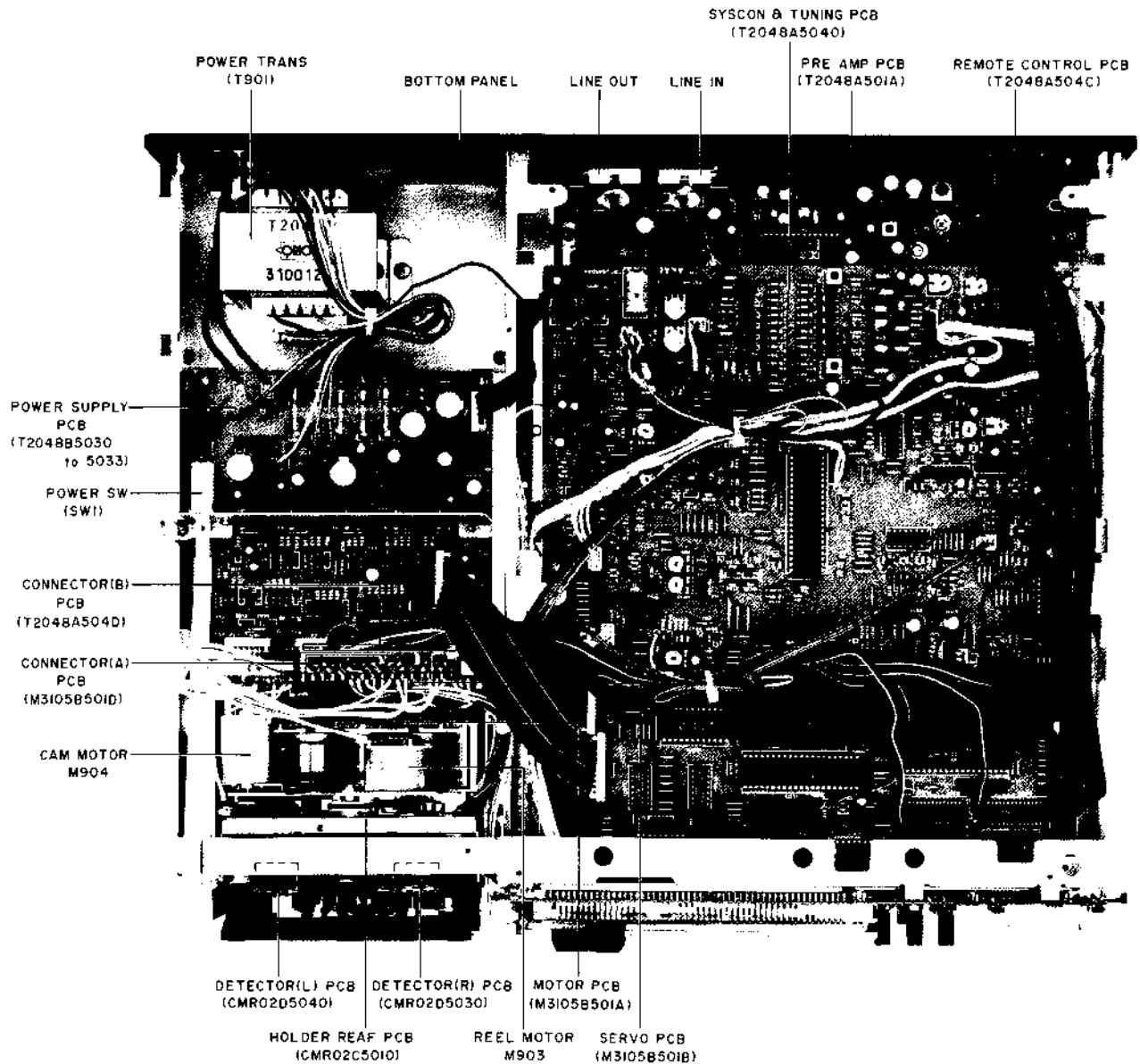

Fig. 4-2 Top View

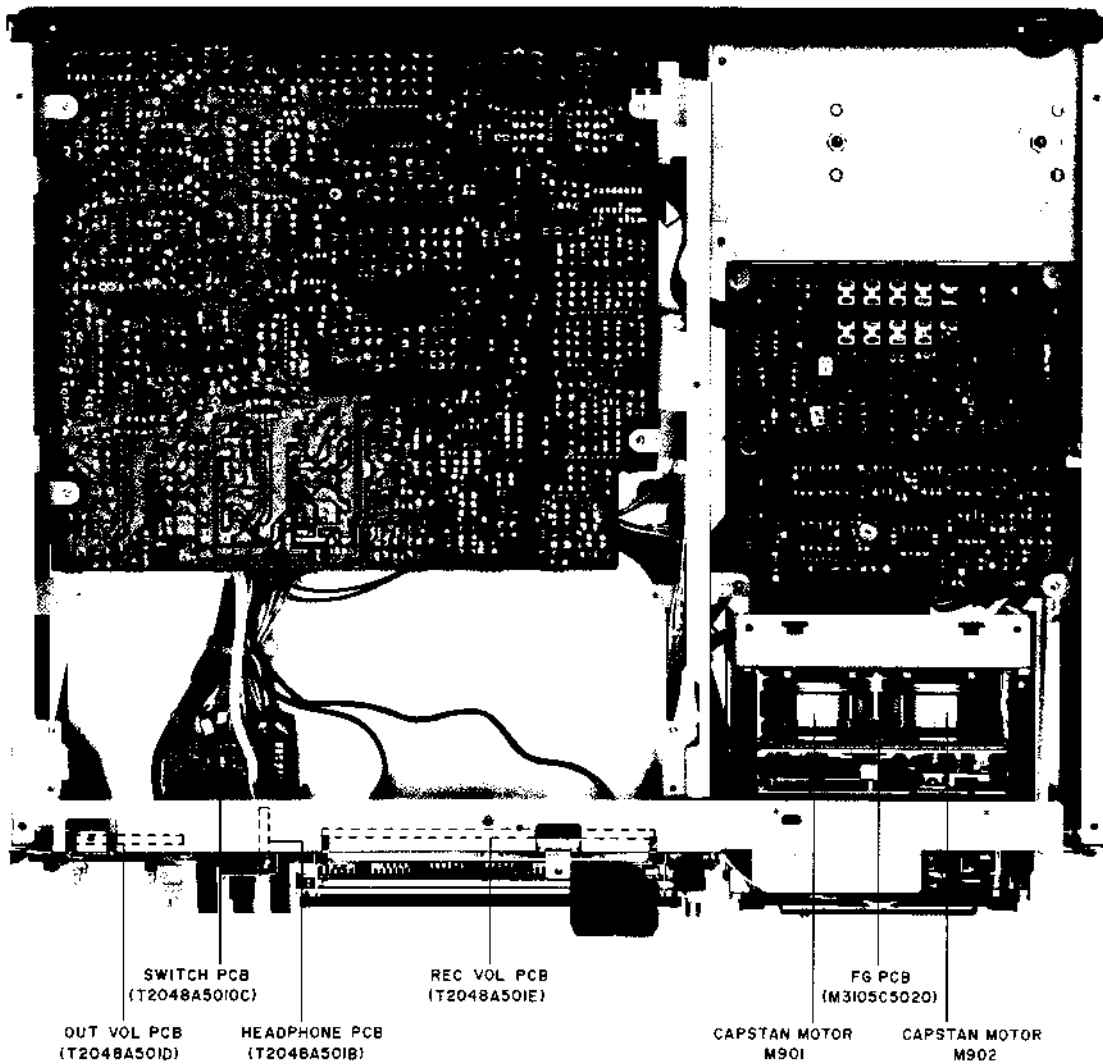

Fig. 4-3 Bottom View

V. MECHANICAL ADJUSTMENT

5-1 PINCH ROLLER PRESSURE MEASUREMENT (Refer to Fig. 5-1)

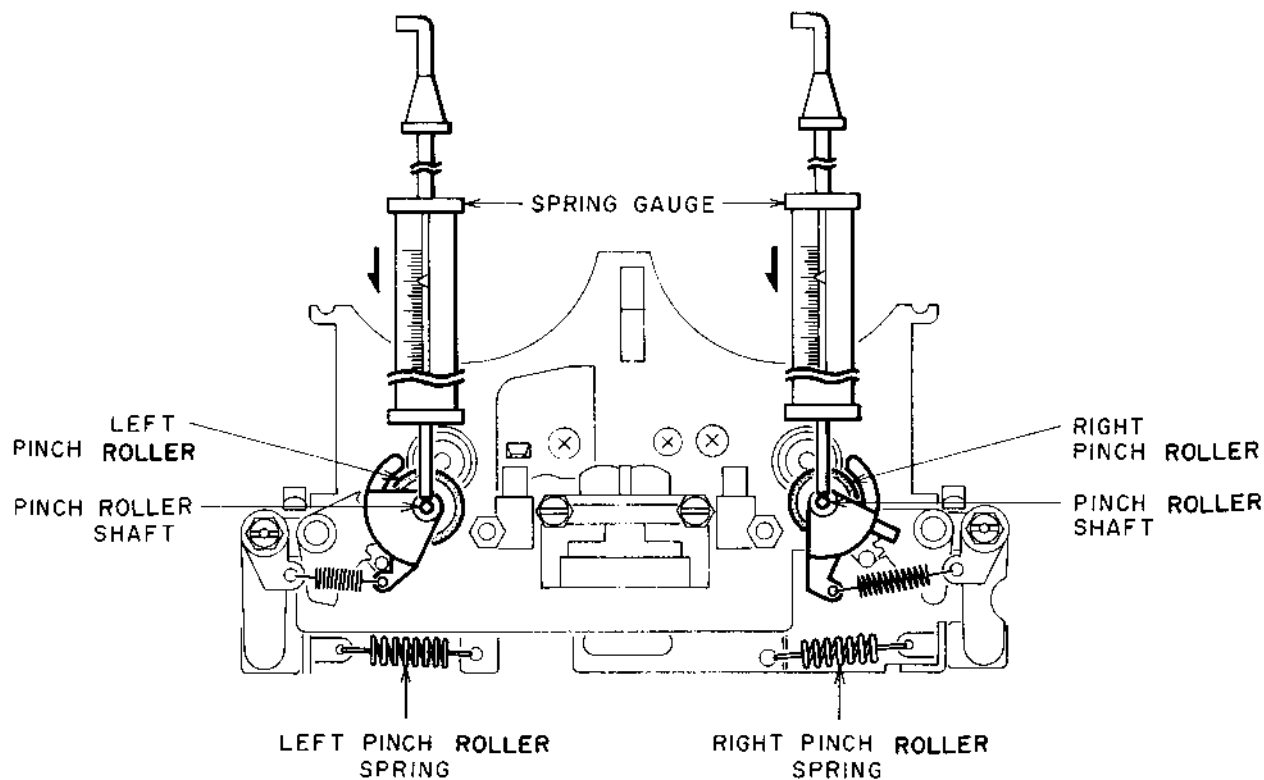

Fig. 5-1

Put in FWD PLAY mode. Push pinch roller shaft down with the spring gauge, and push the pinch roller 1 to 2 mm away from the capstan and release slowly.

Read the spring gauge at the moment the pinch roller touches the capstan and begins to rotate. Specified contact, pressures measurement is

RIGHT SIDE: 450 ± 80 grams

LEFT SIDE: 400 ± 80 grams

Confirm that the pinch roller pressure at REV PLAY mode

RIGHT SIDE: 400 ± 80 grams

LEFT SIDE: 450 ± 80 grams

If there is no measurement obtained, replace the pinch roller spring.

5-2 WINDING TORQUE MEASUREMENT IN EACH MODE (Refer to Fig. 5-2)

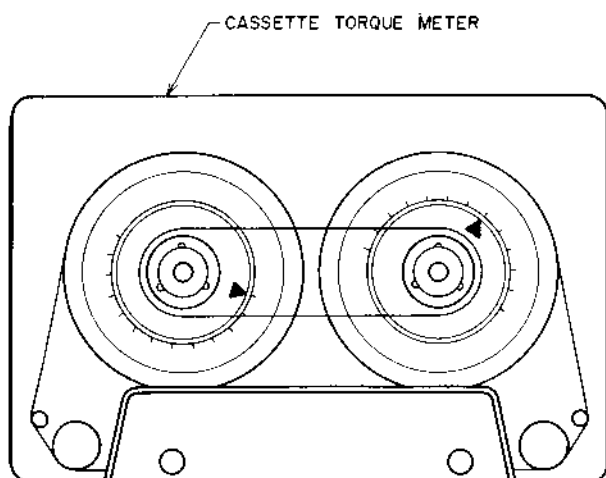

Fig. 5-2

Insert a cassette torque meter (AJ-751179) and measure in each mode. For Fast Forward and Rewind, measure at the end of the tape when the tape has stopped running.

Forward or Reverse mode

Take up Torque: 40^{+15}_{-10} g-cm

Back Tension Torque: 17 ± 3 g-cm

Fast Forward or Rewind mode

Take up Torque: 100^{+50}_{-30} g-cm

5-3 HOW TO INSTALL VOLUME (VR901) AND CAM WHEEL (Refer to Fig. 5-3)

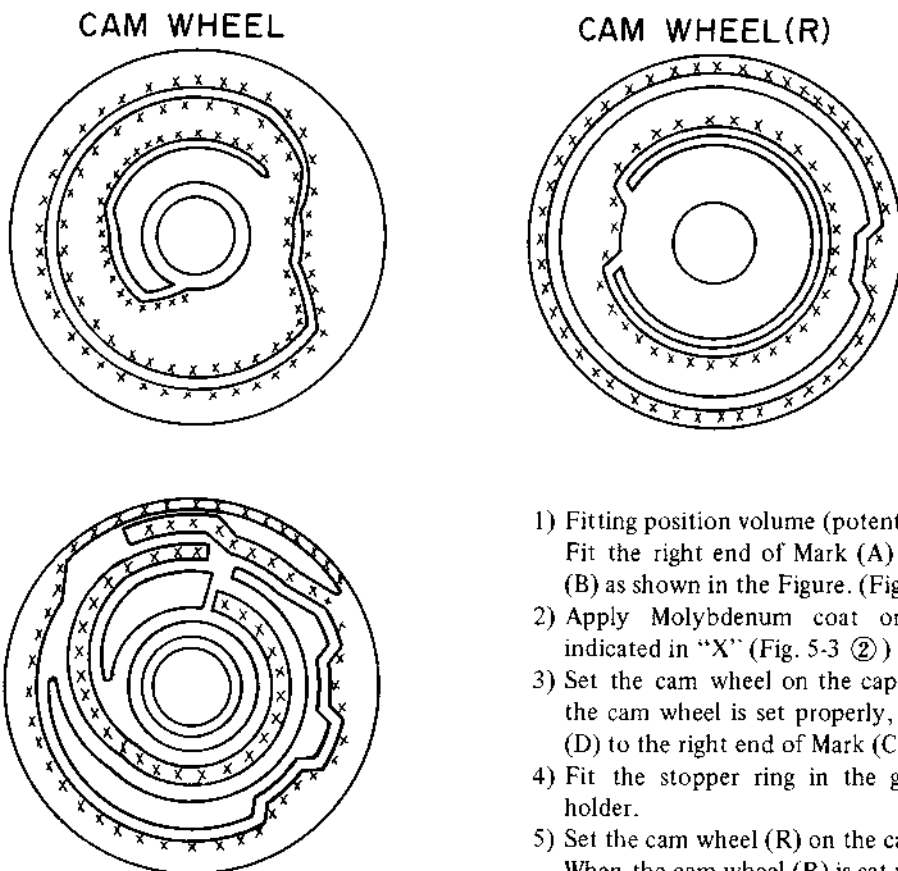
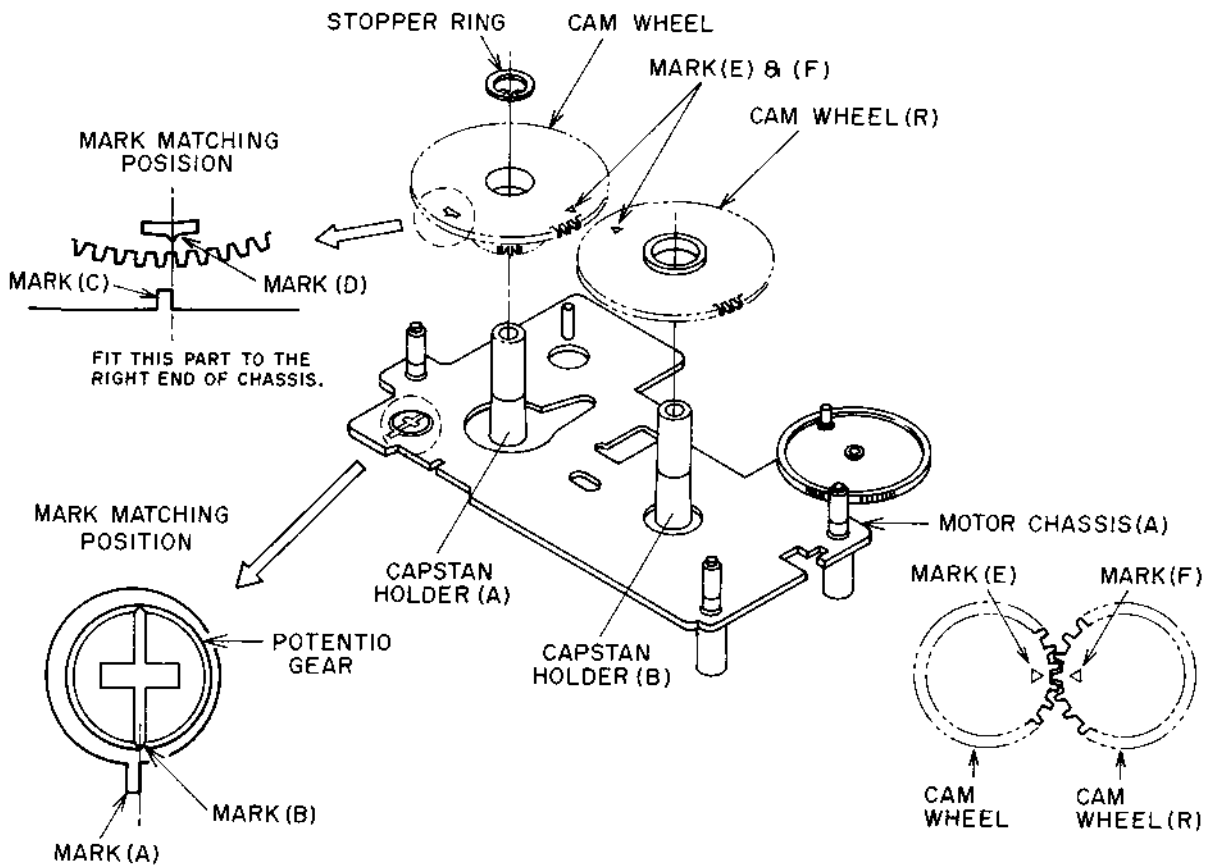

Fig. 5-3

- 1) Fitting position volume (potentio gear)
Fit the right end of Mark (A) to the center of Mark (B) as shown in the Figure. (Fig. 5-3 ①)
- 2) Apply Molybdenum coat on the specified area indicated in "X" (Fig. 5-3 ②)
- 3) Set the cam wheel on the capstan holder (A). When the cam wheel is set properly, fit the center of Mark (D) to the right end of Mark (C). (Fig. 5-3 ③)
- 4) Fit the stopper ring in the groove of the capstan holder.
- 5) Set the cam wheel (R) on the capstan holder (B).
When the cam wheel (R) is set properly, fit the center of Mark (E) to the center of Mark (F). (Fig. 5-3 ④)

5-4 POTENTIO METER PRESET VOLTAGE ADJUSTMENT (Refer to Figs. 5-4 to 5-8)

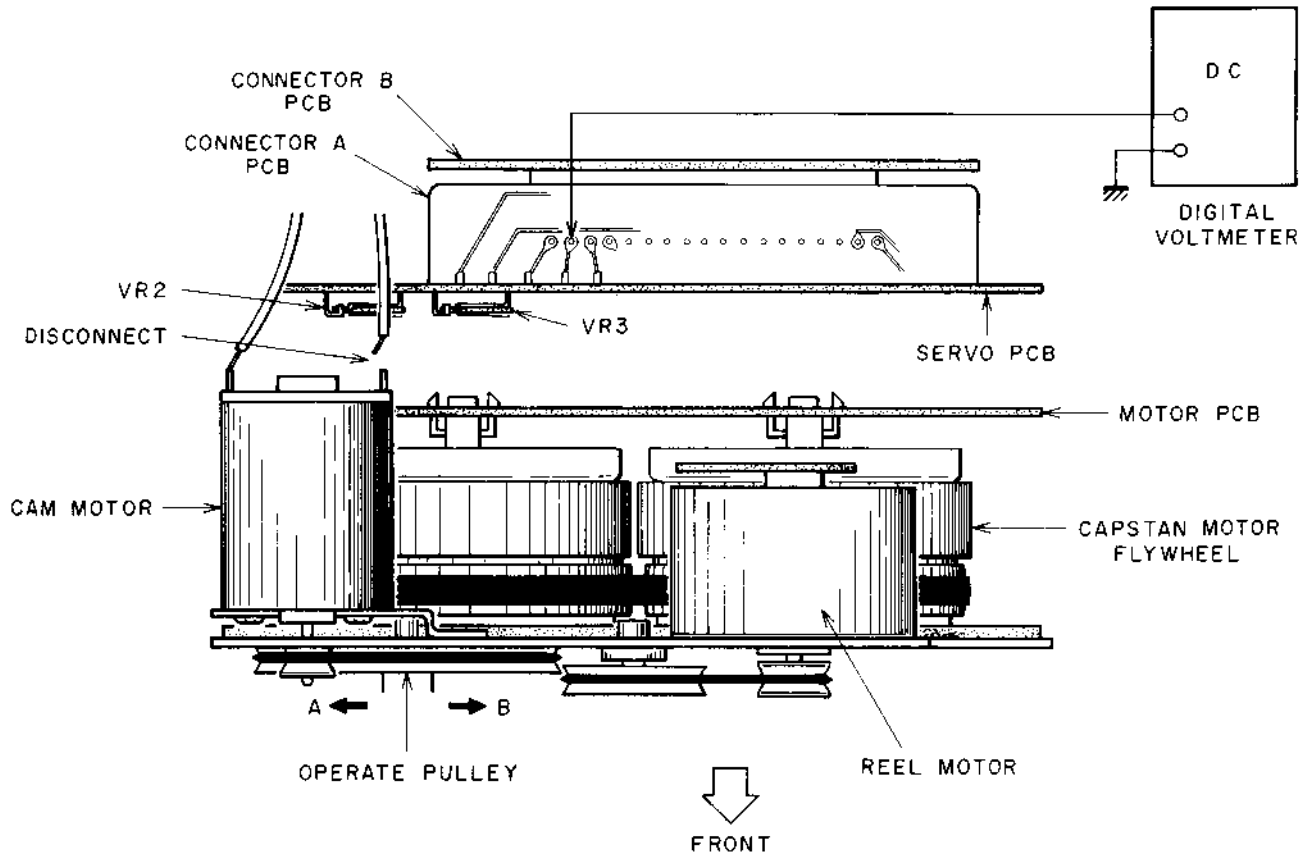

Fig. 5-4

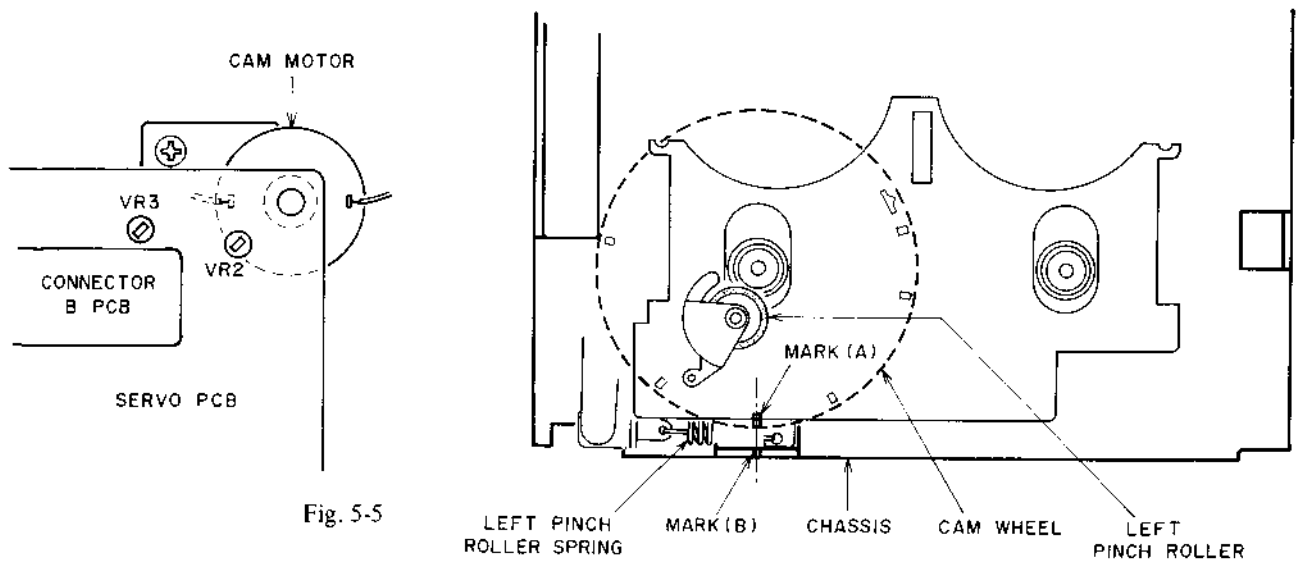

Fig. 5-5

Fig. 5-6

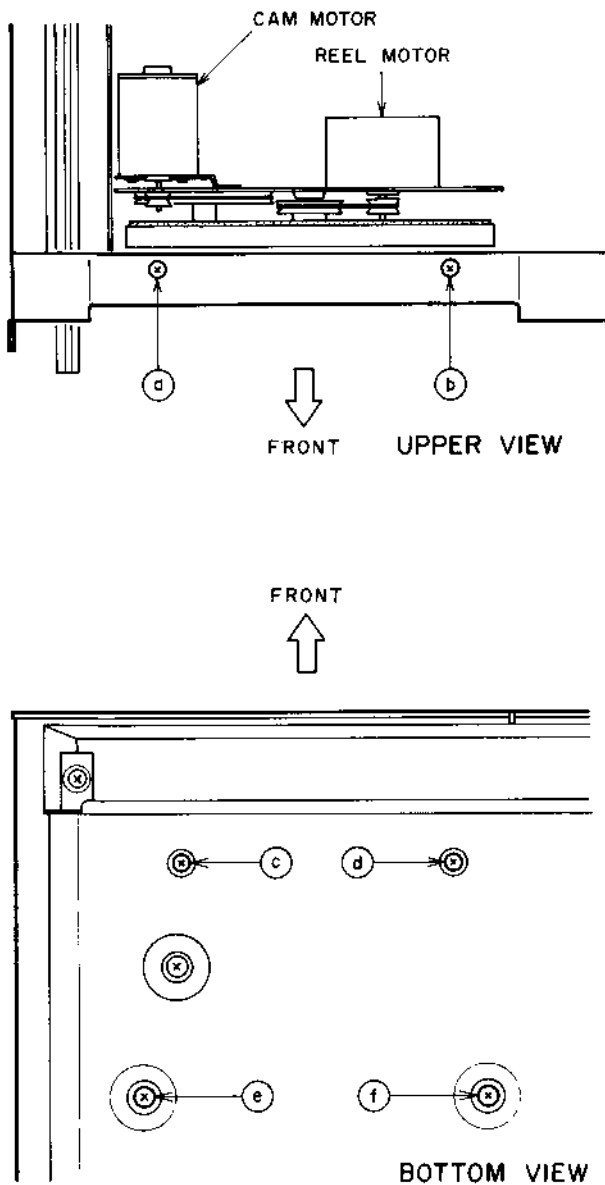

Fig. 5-7

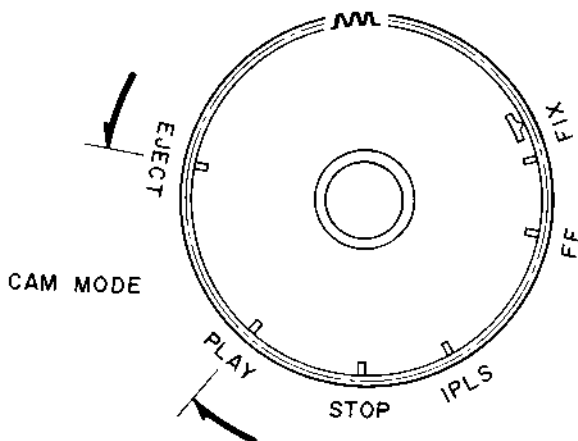

Fig. 5-8

1) LOW VOLTAGE ADJUSTMENT

(Refer to Fig. 5-4 and Fig. 5-5)

- a. With power OFF, remove the connecting cord of the cam motor and turn the operate pulley fully A direction with your fingers.
- b. Connect the digital voltmeter as shown in Fig. 5-4.
- c. With power ON, adjust VR3 so that the voltage reading will be $1.25V \pm 0.05V$.

2) HIGH VOLTAGE ADJUSTMENT

(Refer to Fig. 5-4 and Fig. 5-5)

- a. With power OFF, turn the operate pulley fully B direction with your fingers.
- b. With power ON, adjust VR2 so that the voltage reading will be $9.22V \pm 0.01V$.

3) Repeat Items 1) and 2)

- 4) a. With Power OFF, connect the connecting cord of the motor.
- b. Remove the digital voltmeter.
- c. Remove the screws (a) to (f) on Fig. 5-6 and pull out the MECHA BLOCK slightly.

- 5) a. Set power to ON.
- b. Adjust VR2 slightly so that center of Mark (A) to center of Mark (B) are coincide at STOP Mode as shown in Fig. 5-6 (STOP Mode voltage is about 7.35V when power supply voltage 9.75V at ① on Fig. 5-4).
- c. Remove the cassette lid and the AUTO SYSTEM switch to IPLS mode.
- d. Confirm that the head does not move up and down when the FF and REW switches are alternately pressed.
- e. Turn the reel with fingers in STOP mode to check that the brake works sufficiently. When the brake acts normally, the take-up reel does not turn clockwise while the supply reel does not rotate counterclockwise.

5-5 TAPE SPEED ADJUSTMENT (Refer to Fig. 5-9)

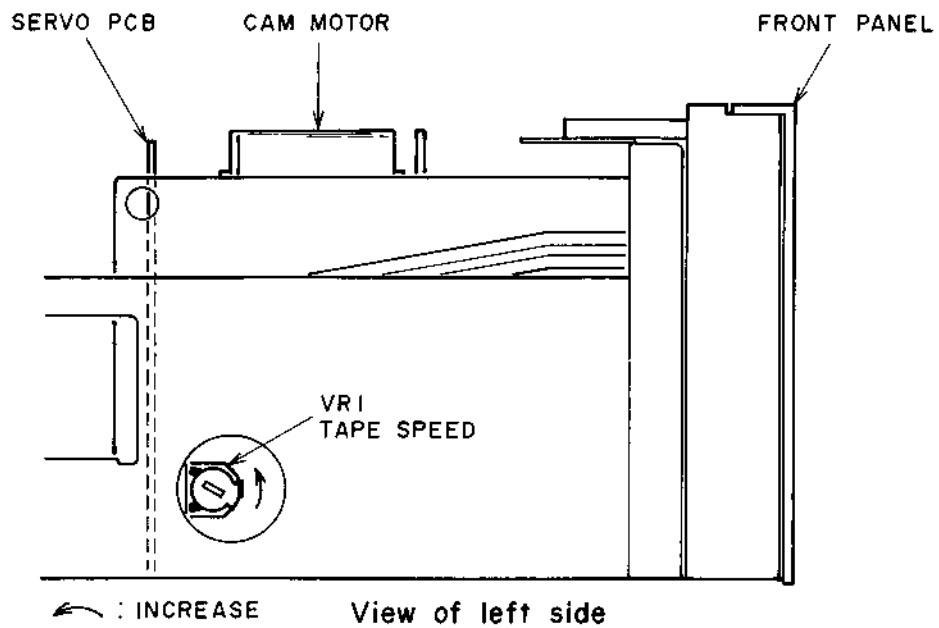

Fig. 5-9

Connect a frequency counter to line output terminals. Playback a 1,000 Hz pre-recorded test tape (AT-750774) and adjust tape speed adjustment volume (SERVO PCB) to obtain a tape speed of 995 Hz to 1005 Hz.

VI. HEAD ADJUSTMENT

6-1 TAPE GUIDE HEIGHT ADJUSTMENT (Refer to Figs. 6-1 and 6-2)

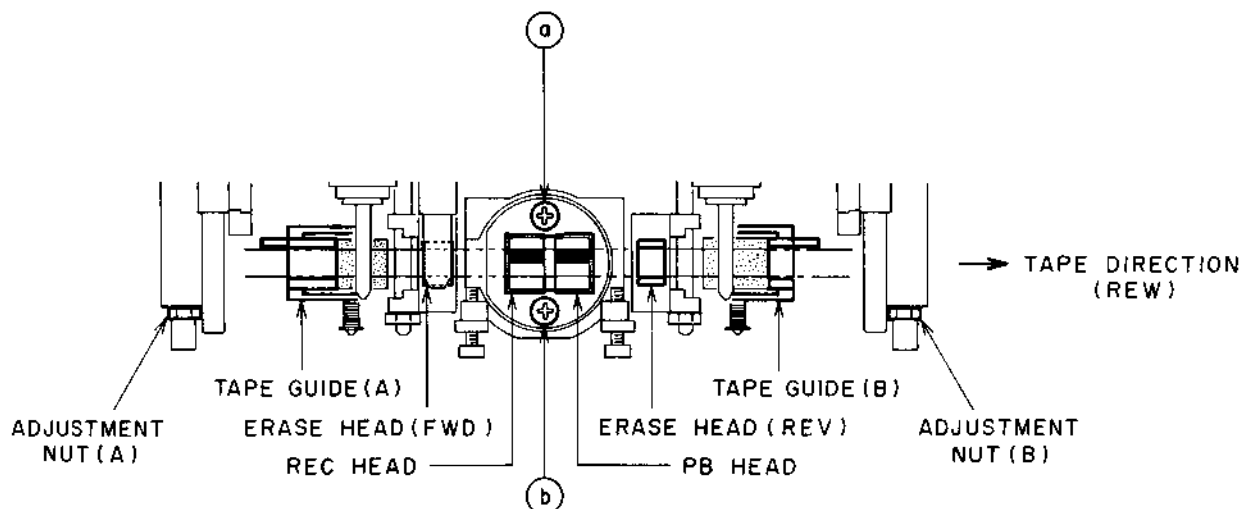

Fig. 6-1

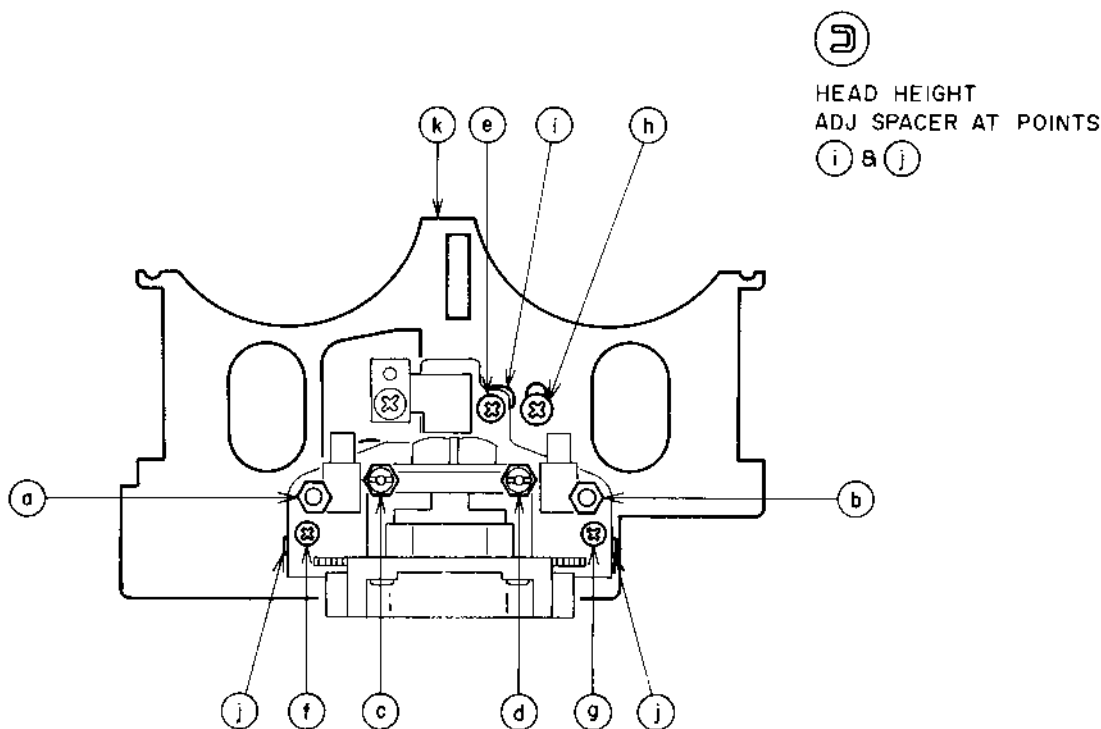

Fig. 6-2

6-1-1 When Pinch Roller Block was replaced.

- a) Set a Mirror Cassette Tape (AJ-751178)
- b) If only the Pinch Roller Block (L) was replaced, select FWD PLAY mode and adjust Tape Guide (A) Height by turning the nut (A) so that the tape runs smoothly by the adjacent edge of both tape guides, and the tape is not hitched by those tape guides.
- c) If only the Pinch Roller Block (R) was replaced, select REV PLAY mode and adjust Tape Guide (B) Height by turning the nut (B) in the same manner as item b).
- d) Apply paint-lock on those nuts after the adjustment.

6-1-2 When only Erase Head was replaced (Refer to Figs. 6-1 and 6-2)

- a) Set a 315 Hz or 333 Hz PB Level Adjustment Tape (AT-750773), and select FWD PLAY mode.
- b) Adjust the Erase Head Height by turning the nuts ① & ② shown in Fig. 6-2, so that the Line out level is -5.5 dBm (315 Hz) or -6.1 dBm (333 Hz).
- c) Select REV PLAY mode, and re-adjust the Erase Head Height by turning the nut ③ & ④ so that the difference in level (L-CH) between FWD and REV modes is within ± 0.5 dBm.
- d) Repeat the adjustments in item a), b) and c).
- e) Set a Mirror Cassette Tape (AJ-751178) and select FWD PLAY mode.
- f) Adjust Tape Guide (A) Height by turning the nut (A) and Erase Head (REV) Height by the nut (B) respectively, so that the tape runs smoothly by the adjacent edge of the Erase Head (FWD) without curling.
- g) Next, select REV PLAY mode, and adjust Tape Guide (B) Height by turning the nut (B) so that the tape runs smoothly by the adjacent edges of both Erase Heads (FWD & REV) without curling.
- h) Confirm that the Line output level (L-CH) is -5.5 dBm and the difference in level (L-CH) between FWD and REV modes is within ± 0.5 dBm.

6-2 REC/PB HEAD AZIMUTH ADJUSTMENT (Refer to Fig. 6-2)

Play back a 10 kHz Head Azimuth Adjustment Tape (AT-750778) and adjust the screws ⑤ (FWD direction) and ⑥ (REV direction), so that the levels of both channels are maxima. (Note: Avoid turning the screws too far as other false maxima exist further away on both sides of the correct position.)

6-3 HEAD HEIGHT ADJUSTMENT (Refer to Figs. 6-1 & 6-2)

This adjustment is not necessary since this models GX-R99 is equipped with Rotary Head System (with REC & PB combination head). However, the confirmation of Head Height is necessary and it can be done as follows:

- 1) Confirm the azimuth in item 6-2.
- 2) Playback a 315 Hz (or 333 Hz) PB level Adjustment Tape (AT-750773) in FWD Play mode, and adjust the

PB level Adjuster (VR5 on Pre Amp PCB) so that the LINE OUT level of left channel is -5.5 dBm.

Then, check the level of the same channel in REV mode. The difference in level between FWD and REV modes should be within ± 0.5 dBm

- 3) If the difference is more than ± 0.5 dBm in item 2), adjust the erase heads by turning both Erase Head Height Adjustment screws ⑦ & ⑧ in the same direction by $1/4$ turn (± 0.1 mm), so that difference is within ± 0.5 dBm.
- 4) The Head Height Adjustment is necessary if still the difference could not be corrected by above adjustment. It can be done by changing the Head Height Adjustment Spacers ⑨ & ⑩ (The thicknesses of these spacers are ⑨ = 0.45 mm, ⑩ = 0.35 mm). Loosen the screws ⑪ & ⑫ for the spacer replacement. If the level is lower in REV mode, it means that the head is too high, therefore replace the spacers by thinner ones. When the level is higher in REV mode, replace them by thicker ones. After the replacement of those spacers, do the same adjustment in item 1) and check the level of LINE OUT is -5.5 dBm ± 0.5 dBm. For the further confirmation, playback a 4 Track head Height Adjustment Tape (1 kHz/4 Track, AT-750775). Line Output level of both channels should be more than -8 dBm and the difference in level between FWD and REV modes should be within ± 1 dB. Otherwise do the fine adjustment in the same manner as item 3) & 4).
- 5) When the head replacement is necessary, loosen only the screws ⑬ & ⑭ in Fig. 6-1 for easy replacement.

6-4 HEAD BLOCK PROJECTION ADJUSTMENT

Use a Cassette Head Projection Gauge (AT-751180) and select FWD or REV play mode.

Loosen the screw ⑮ and adjust chassis Head Part ⑯ so that the gauge indication at the time is 3.1 ± 0.15 mm. After the adjustment, apply paint-lock on the screw ⑮.

- NOTES:**
1. Be sure to clean the heads prior to head adjustment.
 2. Be careful not to use a magnetized driver or other magnetized tools in the vicinity of the heads.
 3. Be sure to demagnetize the heads with a Head Demagnetizer before and after head adjustment.

VII. ELECTRICAL ADJUSTMENT

7-1 PRE-AMPLIFIER P.C BOARD ADJUSTMENT

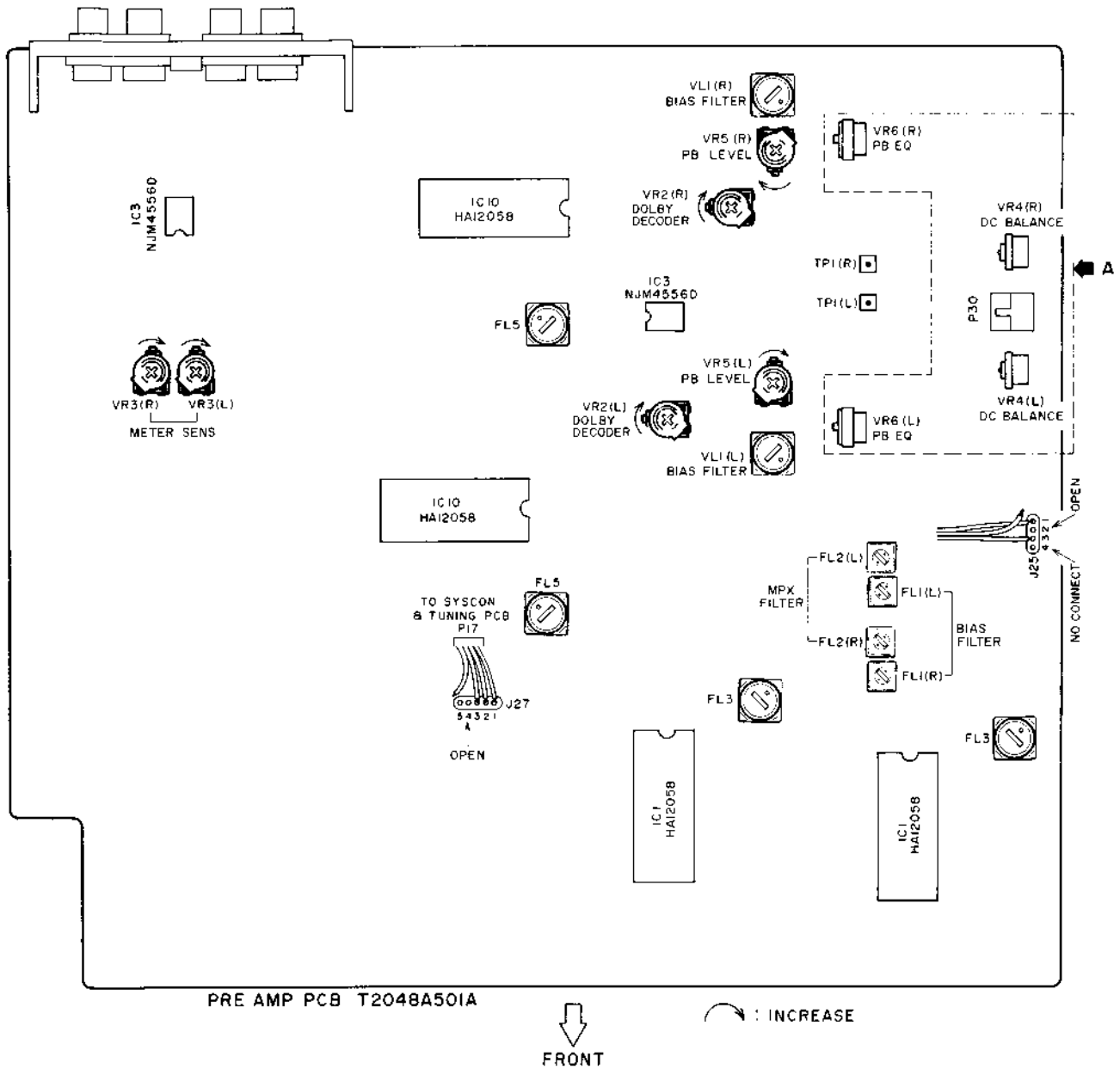

Fig. 7-1 Pre Amp P.C Board

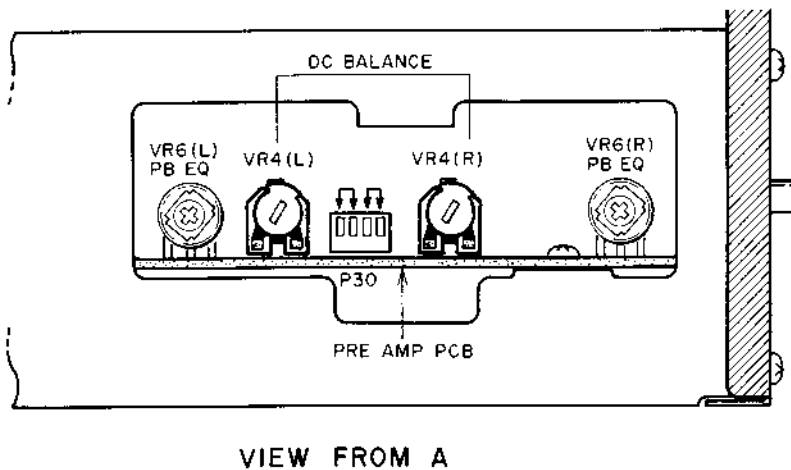

Fig. 7-2

PRE AMP ADJUSTMENT CHART (for more detail, see 7-1-1 to 7-1-3)

Step	Adjustment Item	Mode	Test Tape & Supply Signal	Adjustment Point	Result
1	DC Balance	STOP	Connect INPUT PIN of P30 with GND	VR4 (L) VR4 (R)	TP1 (L) TP1 (R) 0 ± 100 mV D.C
2	P.B Level	FWD PLAY	333 Hz 0 VU Tape (315 Hz 0 VU Tape)	VR5 (L) VR5 (R)	LINE OUT -6.1 ± 0.1 dBm (-5.5 ± 0.1 dBm)
		REV PLAY	333 Hz 0 VU Tape (315 Hz 0 VU Tape)	Confirmation	
3	P.B EQ	FWD PLAY	10 kHz P.B EQ Tape	VR6 (L) VR6 (R)	LINE OUT -20.5 ± 0.2 dBm
		REV PLAY	10 kHz P.B EQ Tape	Confirmation	-20.5 ± 2.0 dBm
4	METER Sensitivity	TAPE MONITOR SOURCE	1 kHz LINE IN (-5.2 dBm LINE OUT)	VR3 (L) VR3 (R)	+1 VU indication on VU METER Display
5	Dolby Decoder	FWD PLAY	315 Hz 0 VU Tape (333 Hz 0 VU Tape)	VR2 (L) VR2 (R)	LINE OUT -5.5 ± 0.3 dBm When Dolby ON (-6.1 ± 0.3 dBm)
6	MPX Filter	REC	19 kHz LINE IN	FL2 (L) FL2 (R)	LINE OUT MIN When MPX SW ON
7	BIAS Filter (Source)	REC/PLAY ↓ REC/PAUSE	No Signal Input METAL Tape (REC VR MAX)	FL1 (L) FL1 (R)	LINE OUT MIN
8	BIAS Filter (P.B)	REC/PLAY	No Signal Input METAL Tape	VL1 (L) VL1 (R)	LINE OUT MIN

7-1-1 PB EQ AMP ADJUSTMENT

(TUNING P.C board is disconnectable from METER P.C board)

- 1) DC Balance
 - a. Remove connector of P30 (PB HEAD Connector)
 - b. Connect INPUT SIGNAL PIN of P30 Pin ①, ④ to GND.
 - c. Adjust VR4 so that the voltage of TP1 will be 0 ± 100 mV DC.
- 2) PB Level
 - a. FWD Play Back 333 Hz (AT-750773) or 315 Hz (AT-750773) PB level adjustment tape and adjust VR5 so that the LINE OUT level will be 333 Hz to -6.1 ± 0.1 dBm or 315 Hz to -5.5 ± 0.1 dBm.
 - b. REV Play Back 333 Hz or 315 Hz PB level adjustment tape and confirm so that the LINE OUT level will be -6.1 ± 0.6 dBm (333 Hz) or -5.5 ± 0.6 dBm (315 Hz).
- 3) PB EQ
 - a. FWD Play Back 10 kHz PB EQ adjustment tape (AT-750778) and adjust VR6 so that the LINE OUT level will be -20.5 ± 0.2 dBm.
 - b. REV Play Back 10 kHz PB EQ adjustment tape and confirm so that the LINE OUT level will be -20.5 ± 2.0 dBm.

7-1-2 METER SENSITIVITY ADJUSTMENT

- a. With the monitor SW to SOURCE and the meter

SW to VU, Supply 1 kHz to LINE IN, a 1 kHz signal -5.2 dBm at LINE OUT.

- b. Adjust VR3 so that the +1 VU.

7-1-3 DOLBY ADJUSTMENT

- 1) Dolby Decoder Adjustment
 - a. FWD Playback 315 Hz PB level adjustment tape (AT-750773).
 - b. Adjust VR2 so that the LINE OUT level will be -5.5 ± 0.3 dBm when Dolby ON. (At 333 Hz PB level adjustment tape, LINE OUT level will be -6.1 ± 0.3 dBm)
- 2) MPX Filter adjustment
 - a. Set a blank tape and set to REC/PLAY mode.
 - b. MPX filter SW OFF, input a signal of 19 kHz from LINE IN.
 - c. Adjust FL2 so that the LINE OUT level will be at minimum when MPX filter SW is turned ON.
- 3) BIAS Filter Adjustment
 - a. Set a metal tape and set to REC/PLAY (or REC/PLAY → REC/PAUSE).
 - b. Adjust FL1 so that the LINE OUT level will be at minimum when the recording volume is set to MAX and the monitor SW to SOURCE.
 - c. Set a metal tape and set to REC/PLAY mode.
 - d. Adjust VL1 so that the LINE OUT level will be at minimum when the monitor SW is set to TAPE.

7-2 TUNING ADJUSTMENT POINT

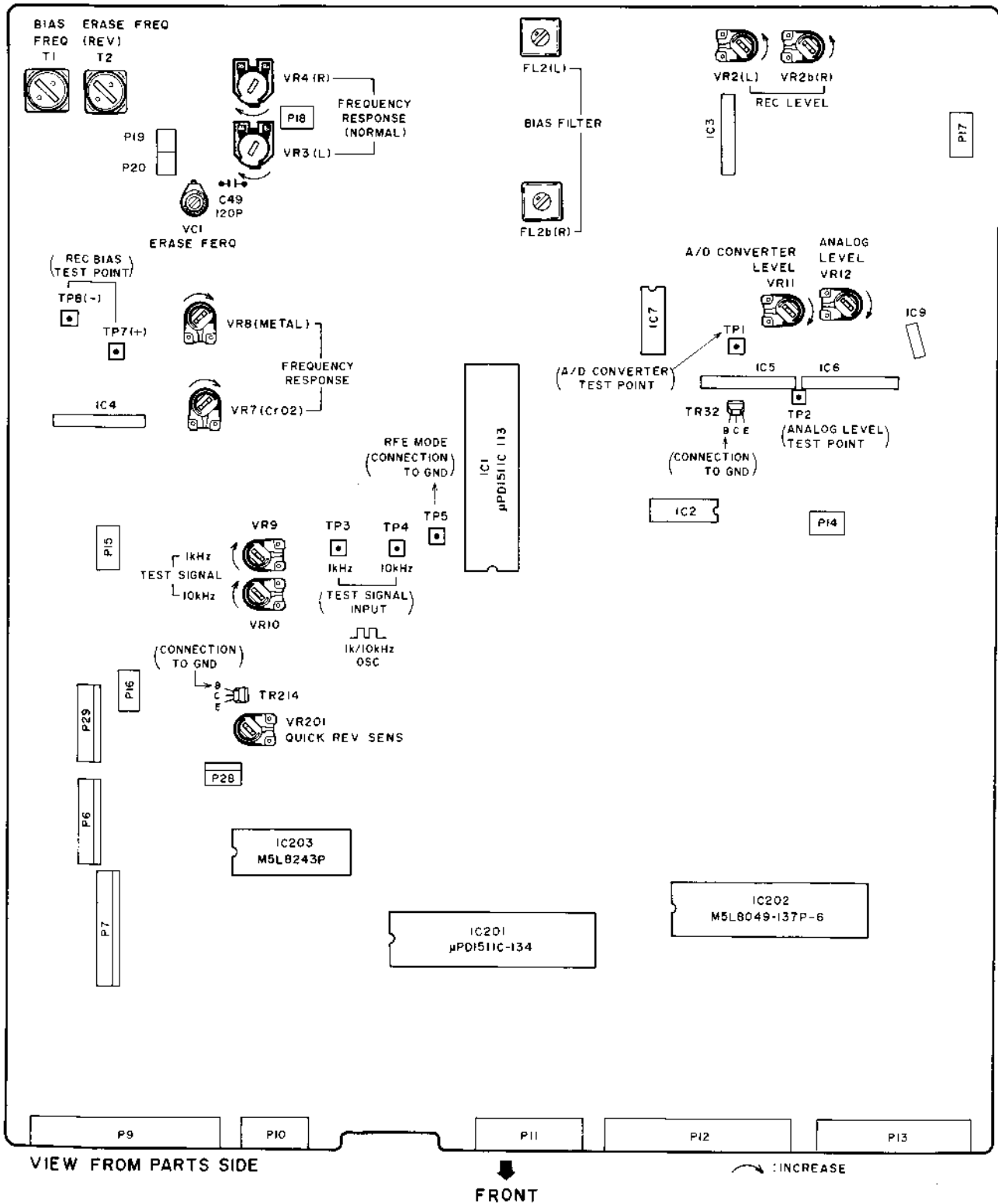

Fig. 7-3 Sys-con & Tuning P.C Board

TUNING ADJUSTMENT CHART (for more detail see 7-2-1 to 7-2-7)

All the adjustment in reference to recording must be carried out in this REF mode.

REF mode will be achieved by connecting TP5 on TUNING P.C BOARD to ground within 3 seconds after the power is turned on. (see note 3)

Step	Adjustment Item	Mode	Test Tape & Supply Signal	Adjustment Point	Result	Remarks
1	Erase OSC	REV REC → REC PAUSE	METAL TAPE	T2	100±0.2 kHz	Connection the counter to P19
		FWD REC → REC PAUSE	METAL TAPE	VC1	100±1 kHz	Connection the counter to P20
2	Rec Bias OSC	FWD REC → REC PAUSE	METAL TAPE	T1	MINIMUM DC VOLTAGE	Between TP7 (+) to TP8 (-)
3	Freq Response (Norm)	FWD REC/PB	NORMAL TAPE 1 kHz, 10 kHz -25.5 dBm	VR4 (L) VR3 (R)	1 kHz to 10 kHz FLAT	
		REV REC/PB	Same as FWD			Confirmation
	(CrO ₂)	FWD REC/PB	CrO ₂ TAPE 1 kHz, 10 kHz -25.5 dBm	VR5	1 kHz to 10 kHz FLAT	
		REV REC/PB	Same as FWD			Confirmation
	(Metal)	FWD REC/PB	METAL TAPE 1 kHz, 10 kHz -25.5 dBm	VR6	1 kHz to 10 kHz FLAT	
		REV REC/PB	Same as FWD			Confirmation
4	Recording Level	FWD REC/PB	NORMAL TAPE 1 kHz -5.5 dBm	VR1 (L) VR2 (R)	-5.5±0.2 dBm	
		REV REC/PB	Same as FWD		FWD RESULT ±0.5 dBm	
5	A/D Converter	FWD REC PAUSE		VR11	3.0±0.05 VDC	Connection the Digital Volt Meter to TP1
6	Analog Level		10 kHz -25.5±0.2 dBm to J27-④	VR12	3.0±0.05 VDC	Unsolder J27-④ connect B of TR32 to GND
7	Test Signal (1 kHz, 10 kHz)	TAPE MONITOR SOURCE	SQUARE WAVE 1 kHz, 1 to 2V to TP3	VR9	-26.5±0.2 dBm	LINE OUT
			SQUARE WAVE 10 kHz, 1 to 2V to TP4	VR10	-26.5±0.2 dBm	LINE OUT
			Repeat 2 and 3 time so that step 7 will be near equal.			

NOTES:

1. Use the following cassette measuring tapes.
Normal Tape: Maxell UD C-60
CrO₂ Tape: TDK SA C-60
METAL Tape: TDK MA C-60
2. a. Refer to Figs. 7-1 and 7-2 for pre amp adjustment.
b. Refer to Fig. 7-3 for tuning adjustment.
3. Caution about REF mode
 - a. REF mode will be cancelled only when the power is turned off.
 - b. Only REC indicator (not TUNING indicator) will be lit for the recording in REF mode.
 - c. Source signal will be mute in REF mode, unless J25 pin ② is disconnected.

7-2-1 ERASE OSC ADJUSTMENT

- Set metal tape and set to REV REC/PLAY mode.
- Connect the frequency counter to P19 (tuning PCB) and adjust T2 so that the frequency will be 100 ± 0.2 kHz.
- Connect the frequency counter to P20 (tuning PCB) and adjust VC1 so that the frequency will be 100 ± 1 kHz. If the proper result could not obtain, cut C49 (120P) and adjust VC1 so that the frequency will be 100 ± 1 kHz.

7-2-2 BIAS OSC ADJUSTMENT

- Connect a DC voltmeter to TP7 (+) and TP8 (-), and adjust T1 so that the voltage will be minimum.

7-2-3 FREQUENCY RESPONSE ADJUSTMENT

- FWD record and playback 1 kHz/10 kHz, -25.5 dBm using a normal tape and adjust VR4 (L-CH) and VR3 (R-CH) so that 1 kHz/10 kHz will be flat response (provided L-R difference is within in 0.5 dBm).
- FWD record and playback 1 kHz/10 kHz, -25.5 dBm using a CrO₂ tape and adjust VR5 so that 1 kHz will be flat response.
- FWD record and playback 1 kHz/10 kHz, -25.5 dBm using a metal tape and adjust VR6 so that 1 kHz/10 kHz will be flat response.
- Confirm REV mode at 3 type tape mode.

7-2-4 RECORDING LEVEL ADJUSTMENT

- FWD record and playback 1 kHz, -5.5 dBm using a normal tape, and adjust VR2 so that the difference between recording and playback level will be 0 ± 0.2 dBm.
- Confirm between FWD and REV within 0.5 dBm.

7-2-5 A/D CONVERTER LEVEL ADJUSTMENT

- Set REC/PAUSE mode.
- Adjust VR11 so that the voltage to GND of TP1 will be 3 ± 0.05 V DC.

7-2-6 ANALOG LEVEL ADJUSTMENT

- Unsolder the wire connected to J27 ④ in PRE AMP PCB.
(Refer to Fig. 7-1) (The wire is Rch PB out)
- Connect the base of TR32, the rear side of R137 or the left side of R138 to GND.
- Input 10 kHz, -25.5 ± 0.2 dBm to Rch PB out terminal of J27 ④.
Measurement Input voltage at between terminal to GND.
(-25 ± 0.2 dBm)
- Adjust VR12 so that the voltage to GND of TP2 will be 3 ± 0.05 V DC.

7-2-7 TEST SIGNAL LEVEL ADJUSTMENT

- Unsolder the wire connected to J25 ② in PRE AMP PCB (Refer to Fig. 7-1).
- Set the monitor SW to SOURCE.
- Input square wave 1 kHz, 1 to 2V to TP3.
Measurement input voltage level at oscilloscope.
- Adjust VR9 so that LINE OUT level will be -26.5 ± 0.2 dBm.
- Input square wave 10 kHz 1 to 2V to TP4.
When TP4 connect input signal, TP3 remove input signal.
- Adjust VR10 so that LINE OUT level will be -26.5 ± 0.2 dBm.
- Repeat 2 and 3 times so that item d and item f will be near equal.

7-3 QUICK REVERSE SENSITIVITY ADJUSTMENT (Refer to Fig. 7-4)

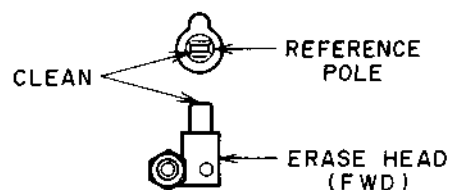

Fig. 7-4

- Make a tapeless cassette pack by removing the tape from the white colored cassette tape.
- Connect the Digital Voltmeter between the Base of TR214 and earth.
- Using the tapeless cassette pack, adjust VR201 (on TUNING & SYS-CON PCB, refer to Fig. 7-3) so that the Digital Voltmeter readings $4.30\text{V} \pm 0.05\text{V}$ DC at FWD playback mode.

NOTE: Clean the Reference Pole and the Erase Head (FWD side), before this adjustment. (Refer to Fig. 7-4)

VIII. DC RESISTANCE OF HEADS

Parts		Name	DC Resistance
REC/PB HEAD	H901	RP4-10	REC: 30 Ohms PB: 305 Ohms
ERASE HEAD (NOR)	H902	E4-11	3.7 Ohms
ERASE HEAD (REV)	H903	E4-11S	
CAPSTAN MOTOR	M901 M902		85 Ohms $\pm 0.5\%$
REEL MOTOR	M903	RF-510T	34 Ohms
CAM MOTOR	M904	EF-2805	20 Ohms

IX. P.C BOARD TITLES AND IDENTIFICATION NUMBERS

P.C Board Title		P.C Board Number
SYS-CON & TUNING	P.C BOARD	T2048A5040
PRE AMP	P.C BOARD	T2048A501A
OUT VOLUME	P.C BOARD	T2048A501D
SWITCH	P.C BOARD	T2048A5010C
HEAD PHONE	P.C BOARD	T2048A501B
POWER SUPPLY	P.C BOARD	T2048B5030 J T2048B5031 U T2048B5032 C A T2048B5033 E V S B
FILTER	P.C BOARD	M3105B501E
METER	P.C BOARD	T2048A5020
SERVO	P.C BOARD	M3105B501B
POTENTION	P.C BOARD	M3105B501C
CONNECTOR A	P.C BOARD	M3105B501D
CONNECTOR B	P.C BOARD	T2048A504D
MOTOR	P.C BOARD (CAPSTAN)	M3105B501A
FG	P.C BOARD	M3105C5020
REMOTE CONTROL	P.C BOARD	T2048A504C
HOLDER LEAF SW	P.C BOARD	CMR02C5010
FLEXIBLE	P.C BOARD	CHR02A5050
DETECTOR (L)	P.C BOARD	CMR02D5040
DETECTOR (R)	P.C BOARD	CMR02D5030
LED	P.C BOARD	CMR02D5020
REC VOLUME	P.C BOARD	T2048A501E

SECTION 2

PARTS LIST

TABLE OF CONTENTS

RECOMMENDED SPARE PARTS	25
1. MECHA CMR02 BLOCK	26
2. MOTOR BLM-500 BLOCK	28
3. SYSCON AND TUNING P.C BOARD BLOCK	30
4. PRE AMP IC P.C BOARD BLOCK	31
5. METER P.C BOARD BLOCK	31
6. POWER SUPPLY P.C BOARD BLOCK	32
7. MOTOR P.C BOARD BLOCK	32
8. ASSEMBLY BLOCK	33
9. FINAL ASSEMBLY BLOCK	34
INDEX	35

Resistors and Capacitors which are not listed in this parts list, please refer to COMMON LIST FOR SERVICE PARTS.

ATTENTION

1. When placing an order for parts, be sure to list the parts no. model no., and description. There are instances in which if any of this information is omitted, parts cannot be shipped or the wrong parts will be delivered.
2. Please be careful not to make a mistake in the parts no. If the parts no. is in error, a part different from the one ordered may be delivered.
3. Because parts number and parts unit supply in the Preliminary Parts List may be partially changed, please use this parts list for all future reference.

HOW TO USE THIS PARTS LIST

1. This Parts List shows the parts that are considered necessary for repairs. Other parts, such as resistors and capacitors, are shown in the "Common List for Service Parts". Select and order such parts from the "Common List for Service Parts".
2. The Recommended Spare Parts shows those parts in the Parts List which are considered particularly important for service.
3. Parts not shown in the Parts List and "Common List for Service Parts" will not be supplied in principle.
4. How to read list

a) Mechanism Block

b) P.C Board Block

2. HEAD BASE BLOCK

REF. NO.	PARTS NO.	DESCRIPTION
2-1x	BH-T2023A320A	HEAD BASE BLOCK GX-F66R
2-2	HP-H2206A010A	HEAD R/P PR4-8FU C
2-3	ZS-477876	PAN20x03STL CMT
2-4	ZS-536488	BID20x08STL CMT
2-5	ZG-402895	CS ANGLE ADJUST SPRING

SP (Service Parts) Classification

A small "x" indicates the inability to show that particular part in the Photo or Illustration.

This number corresponds with the individual parts index number in that figure

This number corresponds with the Figure Number

6. SYS. CON. P.C BOARD BLOCK

REF. NO.	PARTS NO.	DESCRIPTION
6-1	BA-T2034A070A	PC SYS CON BLK GX-F44R
6-IC1	EI-324536	IC HD14049BP
6-IC2	EI-336801	IC MB8841-564M
6-IC3	EI-331661	IC SN7405N
6-IC4	EI-336725	IC M54527P
6-TR1to4	ET-200985	TR 2SC2603 F,G
6 ⁵ TR5to28	ET-554657	TR 2SA733A P,Q
6-D1	ED-318292	D SILICON H 1S2473T-77 T26
6-D2to4	ED-308952	D GERMA V 1K34A-LR F07
6-D5to10	ED-318292	D SILICON H 1S2473T-77 T26
6-X1	EI-318384	OSC X'TAL NC-18C 3.579545MHZ

SP (Service Parts) Classification

This reference numbers corresponds with symbol numbers of Schematic Diagrams.

5. Both the kind of part and installation position can be determined by the Parts Number. To determine where a parts number is listed, utilize Parts Index at end of Parts List. It is necessary first of all to find the Parts Number. This can be accomplished by using the Reference Number listed at right of parts number in the Parts Index.

WARNING

⚠ INDICATES SAFETY CRITICAL COMPONENTS. FOR CONTINUED SAFETY, REPLACE SAFETY CRITICAL COMPONENTS ONLY WITH MANUFACTURER'S RECOMMENDED PARTS.

AVERTISSEMENT

⚠ IL INDIQUE LES COMPOSANTS CRITIQUES DE SURETE. POUR MAINTENIR LE DEGRE DE SECURITE DE L'APPAREIL NE REMPLACER LES COMPOSANTS DONT LE FONCTIONNEMENT EST CRITIQUE POUR LA SECURITE QUE PAR DES PIECES RECOMMANDEES PAR LE FABRICANT.

RECOMMENDED SPARE PARTS

Because, if the parts listed below are on hand, almost any repair can be accomplished, we suggest that you stock these Recommended Spare Parts Items.

NO.	PARTS NO.	DESCRIPTION
1	BH-T2049A070A	HEAD BLK GX-R99
2	BM-B604527	Δ MOTOR OPERATION PART
3	BM-B604526	Δ REEL MOTOR PART
4	BM-M3105A010A	MOTOR BLM-500
5	BR-T2049A040A	REEL TABLE BLK GX-R99
6	BT-347972	Δ TRANS POWER T2048AC
7	BT-347974	Δ TRANS POWER T2048BS
8	BT-347973	Δ TRANS POWER T2048EV
9	BT-347971	Δ TRANS POWER T2048J
10	BT-347970	Δ TRANS POWER T2048U
11	BZ-T2049A020A	MECHA CMR02 BLK GX-R99
12	EC-348292	C S-FIX H ECR-BA160N11 12-160
13	ED-330319	Δ D SILICON DBA10B 100/1.0A
14	ED-330987	Δ D SILICON RB152 200/1.5A
15	ED-330622	Δ D SILICON 1SR35-100VL 100/1.0A
16	N ED-308952	D GERMA V 1K34A-LR F07
17	ED-337010	D LED SLF201C GRN
18	ED-348121	D LED TLY143 GRN
19	ED-348122	D LED TLY143 YLW
20	ED-301911	D SILICON H DS448
21	ED-344280	D SILICON H GMA-01-FY2 F05
22	ED-624903	D SILICON H 1S2473
23	N ED-200468	D SILICON V DS448-VB6
24	N ED-346633	D SILICON W03B F10 100/1.0A
25	ED-330622	D SILICON 1SR35-100VL 100/1.0A
26	N ED-346478	D ZENER H HZ11FA F10 B2
27	N ED-346493	D ZENER H HZ15FA F10 2
28	N ED-346503	D ZENER H HZ20FA F10 2
29	N ED-346505	D ZENER H HZ22FA F10 1
30	ED-346462	D ZENER H HZ7FA F10 C2
31	N ED-346440	D ZENER H HZ5FA F10 B1
32	N ED-346441	D ZENER H HZ5FA F10 B2
33	N ED-346446	D ZENER H HZ5FA F10 C3
34	N ED-346450	D ZENER H HZ6FA F10 B2
35	N ED-346452	D ZENER H HZ6FA F10 C1
36	N ED-346454	D ZENER H HZ6FA F10 C3
37	N ED-346473	D ZENER H HZ9FA F10 C3
38	ED-348001	D ZENER V HZ2B-1S7
39	N ED-338082	D ZENER V HZ5C-1S7
40	EF-601942	Δ FUSE SEMKO T 250V 0.63A
41	EF-623103	Δ FUSE SEMKO T 250V 1.00A
42	EF-601964	Δ FUSE SEMKO T 250V 1.60A
43	EF-306124	Δ FUSE TSC A 250V 0.63A
44	EF-309387	Δ FUSE TSC A 250V 1.00A
45	EF-311839	Δ FUSE TSC A 250V 1.60A
46	EF-305703	Δ FUSE TSC 125V 0.63A
47	EF-310229	Δ FUSE TSC 125V 1.00A
48	EF-308847	Δ FUSE TSC 125V 1.60A
49	EH-337380	FILTER CE KMFC-1001S 3.580MHZ
50	EH-336775	FILTER DB D07001K 19KHZ
51	EH-336776	FILTER DB D07003K 100KHZ
52	EH-347991	OSC CE CSA6.00MS 6MHZ
53	EI-336987	HALL ELEMENT DHD-H150
54	EI-330352	IC BA6109
55	EI-348105	IC HA12010
56	EI-349196	IC HA12058
57	EI-336761	IC LA6458S
58	EI-337013	IC LB1290
59	EI-345765	IC LB1292
60	EI-338171	IC LC4069UB
61	EI-348111	IC LC4071B
62	EI-337008	IC LC7800
63	EI-352232	IC M5L8049-154P-6
64	EI-348110	IC M5L8243P
65	EI-348701	IC M51143L
66	EI-337228	IC M5218L0
67	EI-348123	IC M5230AL
68	EI-307644	IC NJM4556D
69	EI-201940	IC NJM4558S

NO.	PARTS NO.	DESCRIPTION
70	EI-337126	IC TA7332P
71	EI-337529	IC TA78L005AP
72	N EI-310036	IC TC4066BP
73	EI-336992	IC UPC1043C
74	EI-337360	IC UPC4082C
75	EI-349145	IC UPD1511C-113
76	EI-348108	IC UPD1511C-134
77	EI-338238	IC UPD4051BC
78	EI-347923	IC UPD4071BC
79	EM-347978	IND FL BG-167Z
80	EO-348100	COIL OSC 1 25-5059-22
81	EO-348101	COIL OSC 2 25-5060-02
82	EO-315758	COIL TUN 1 100Z-431 100.00KHZ
83	EO-336738	COIL TUN 1 102AZ-004 19.80KHZ
84	EO-337055	COIL VARI 1 FE002S 10MH
85	EO-331280	COIL VARI 1 46-1072-11 22MH
86	EQ-344440	RELAY SIGNAL G2V-282P 2TR
87	ER-348272	Δ R FUSE ERD2FC S10 1/4W 12R0G
88	ER-318248	Δ R FUSE ERD2FC S10 1/4W 47R0G
89	ER-331188	Δ R FUSE ERD2FC S10 1/4W 8R2J
90	ER-350808	Δ R FUSE ERQ14AJ S10 1/4W 181J
91	ER-323487	R MF H F10 1/4W 1503F
92	ES-336990	SW LEAF BSW-169 01-1 NO
93	ES-336990	SW LEAF BSW-169 01-1 NO
93	ES-344253	SW LEAF MSW-1418J 01-1 NO
94	ES-344257	SW LEAF MSW-1418L 01-1 NO
95	ES-337427	SW MICRO SS-01-E
96	ES-348133	SW PUSH ESB-62746 3 THROW
97	ES-348998	SW PUSH SDL1P 01-1
98	ES-346260	SW PUSH SPH121A 2-02-02N
99	ES-305733	SW SELECTOR HXW0131-260 01-4
100	ES-336780	SW TACT KHH10902
101	ET-310341	PHOTO SENSOR PT350 T
102	ET-345091	PHOTO SENSOR SPI-201-40 B,C
103	ET-321016	TR FET 2SK117 GR,BL
104	N ET-341400	TR FET 2SK170 BL, GR
105	N ET-337234	TR FET 2SK270 GR, BL
106	N ET-200558	TR 2SA1115 E,F
107	ET-350806	TR 2SA1115 F,G
108	ET-348950	TR 2SA1345
109	ET-349725	TR 2SA1391 S,T
110	ET-349718	TR 2SA1392 S,T
111	N ET-554657	TR 2SA733A P,Q
112	ET-337112	TR 2SA798 F,G
113	N ET-337012	TR 2SA984K D,E
114	ET-337968	TR 2SA999 E,F
115	ET-322598	TR 2SB632K E,F
116	ET-318237	TR 2SB764 E,F
117	N ET-337188	TR 2SB774 P,Q
118	N ET-347969	TR 2SB808-V F,G,H
119	ET-336997	TR 2SB808-V G,H
120	N ET-308976	TR 2SC1815 BL,GR
121	N ET-337011	TR 2SC2274K D,E
122	N ET-310833	TR 2SC2274K E
123	ET-328578	TR 2SC2320 E,F
124	N ET-330270	TR 2SC2320 F,G
125	N ET-200505	TR 2SC2603 E,F
126	N ET-200985	TR 2SC2603 F,G
127	ET-3409080	TR 2SC3382 S,T
128	ET-349081	TR 2SC3383 S,T
129	ET-350795	TR 2SC3399
130	N ET-319638	TR 2SD1012-V F,G,H
131	ET-347961	TR 2SD1012-V G
132	N ET-328868	TR 2SD1012-V G,H
133	ET-350816	TR 2SD549 E,F
134	ET-350948	TR 2SD612K F
135	N ET-307349	TR 2SD794 P,Q
136	N EV-321637	R S-FIX H D8 3P 104
137	N EV-315414	R S-FIX H D8 3P 203
138	N EV-315752	R S-FIX H D8 3P 204
139	N EV-322416	R S-FIX H D8 3P 303
140	N EV-315413	R S-FIX H D8 3P 503
141	EV-336850	R S-FIX H KVSF807U 3P 202

NO.	PARTS NO.	DESCRIPTION
142	EV-336851	R S-FIX H KVSF807V 3P 501
143	EV-337995	R S-FIX H RVF8P01 3P 103
144	EV-337993	R S-FIX H RVF8P01 3P 203
145	EV-338588	R S-FIX H RVF8P01 3P 503
146	EV-330531	R S-FIX H TM8KV2-1S 3P 0.50W 503
147	EV-325994	R S-FIX V H1052A 3P 0.15W 103
148	EV-345297	R S-FIX V TM8KH1-1S 3P 0.50W 101
149	EV-341250	R S-FIX V TM8KH1-1S 3P 0.50W 503
150	EV-337052	VR ROTARY 16L10XOR B103
151	EV-337840	VR SLIDE 100P2WV0A A503
152	EV-337841	VR SLIDE 30P2SV0A B103
153	HE-H2302A010A	HEAD E E4-11
154	HE-H2303A010A	HEAD E E4-11S
155	HP-H2404A010A	HEAD COMBO RP4-10
156	MB-345193	BELT CAPSTAN F222M
157	MB-345179	BELT GEAR S 80M
158	MB-344989	BELT OPERATION (B) S 128M
159	MI-T2049A030A	IDLER BLK GX-R99
160	MP-336204	ROLLER PINCH (B)
161	MP-344980	ROLLER PINCH (B)
162	MZ-344004	GEAR HEAD
163	MZ-336005	GEAR POTENTION
164	MZ-B345155	GEAR REVERSE PART

NOTE N: NEW PARTS

MECHA CMR02 BLOCK

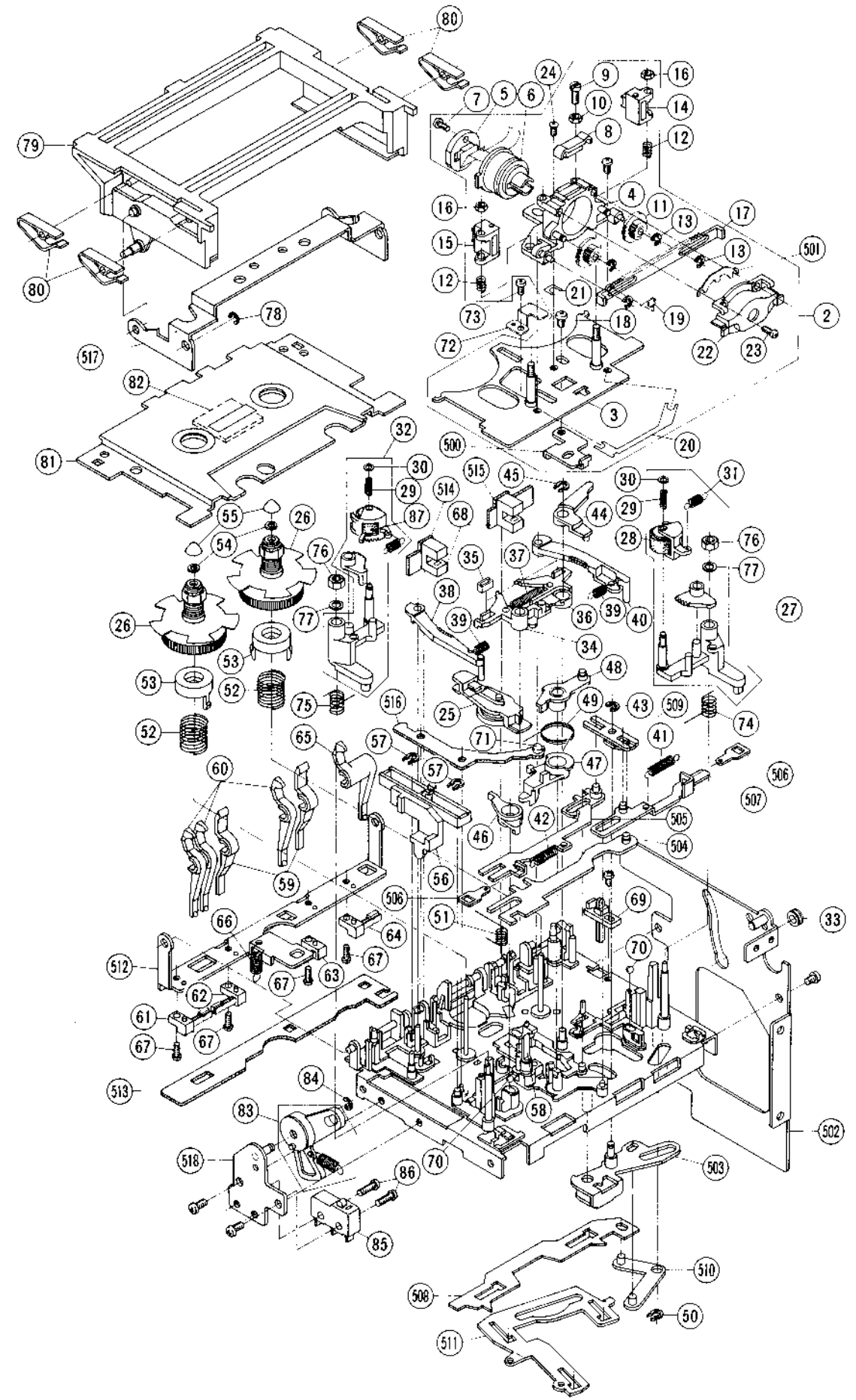

1. MECHA CMR02 BLOCK

REF. NO.	PARTS NO.	DESCRIPTION
1-1	BZ-T2049A020A	MECHA CMR02 BLK GX-R99
HEAD BLOCK		
1-2	BH-T2049A070A	HEAD BLK GX-R99
1-3	MA-B344940	CHASSIS HEAD PART
1-4	HZ-B344009	HOUSING ROTARY PART
1-5	HP-H2404A010A	HEAD COMBO RP4-10
1-6	HZ-B344006	HOLDER ROTARY PART
1-7	ZS-245147	CTS20x06STL BNI
1-8	HZ-344011	GUIDE ROTARY HEAD
1-9	ZS-344001	SCREW AZIMUTH
1-10	ZW-273734	N20BRS NI3 1
1-11	MZ-344004	GEAR HEAD
1-12	ZG-351688	SP PUSH EH
1-13	ZW-391397	RING E120SUP CMT
1-14	HE-H2302A010A	HEAD E E4-11
1-15	HE-H2303A010A	HEAD E E4-11S
1-16	ZW-618884	N20STL CMT 1
1-17	TC-344942	SLIDE CHANGE
1-18	ZS-481645	BID26x03STL CMT
1-19	ZG-344988	SP TORSION RACK
1-20	ZW-350766B	SPACER ADJUST (B)
1-20	ZW-350766C	SPACER ADJUST (C)
1-20	ZW-350766D	SPACER ADJUST (D)
1-21	ZW-344639G	SPACER ADJUST (G) 0.40MM
1-21	ZW-344639H	SPACER ADJUST (H) 0.45MM
1-21	ZW-344639J	SPACER ADJUST (I) 0.50MM
1-22	HZ-344015	COVER HOUSING
1-23	ZS-345773	BID17x06STL BNI
1-24	ZS-524812	CTS20x04STL CMT
IDLER BLOCK		
1-25	MI-T2049A030A	IDLER BLK GX-R99
REEL TABLE BLOCK		
1-26	BR-T2049A040A	REEL TABLE BLK GX-R99
ARM PINCH ROLLER (R) BLOCK		
1-27	BL-T2049A050A	ARM PINCH ROLLER (R) BLK GX-R99
1-28	MP-344980	ROLLER PINCH (B)
1-29	ZG-349030	SP PUSH GUIDE TAPE HOLDER
1-30	ZW-350890	PW12x032x025PSL
1-31	ZG-349178	SP PULL GUIDE TAPE
ARM PINCH ROLLER (L) BLOCK		
1-32	BL-T2049A060A	ARM PINCH ROLLER (L) BLK GX-R99
MECHA CMR02 BLOCK		
1-33	SZ-336166	COLLAR LID
1-34	ML-344949	LEVER BRAKE (A)
1-35	TC-336146	BRAKE RUBBER
1-36	ML-344950	LEVER BRAKE (B)
1-37	ZG-312946	SP T1-3.2/0.29-16.0 T1-062
1-38	ML-B344951	LEVER BT(L) PART
1-39	ZG-344987	SP PULL BT
1-40	ML-B344952	LEVER BT(R) PART
1-41	ZG-349177	SP PULL PINCH ROLLER (L)
1-42	ZG-344985	SP PULL PINCH ROLLER (R)
1-43	ZW-356657	RING E 150SUP CMT
1-44	ML-345073	LEVER BT CHANGE (R)
1-45	ZW-329422	RING CS0300
1-46	ML-345074	LEVER BT CHANGE (L)
1-47	ML-344961	LEVER HEAD BASE (A)
1-48	ML-B344962	LEVER HEAD BASE (B) PART
1-49	ZG-344964	SP TORSION (A)
1-50	ZW-329422	RING CS0300
1-51	ZG-344960	SP TORSION IDLER
1-52	ZG-336141	SP PUSH BT
1-53	TC-336142	HOLDER BT SP
1-54	ZW-330073	PW21x040x020
1-55	MT-305793	REEL CAP
1-56	TC-336161	SLIDE EJECT
1-57	ZW-329422	RING CS0300

REF. NO.	PARTS NO.	DESCRIPTION
1-58	TC-344982	PROP REFERENCE
1-59	ML-344953	LEVER DETECTION (A)
1-60	ML-344954	LEVER DETECTION (B)
1-61	ES-344257	SW LEAF MSW-1418L 01-1 NO
1-62	ES-344253	SW LEAF MSW-1418J 01-1 NO
1-63	ES-344257	SW LEAF MSW-1418L 01-1 NO
1-64	ES-344253	SW LEAF MSW-1418J 01-1 NO
1-65	ML-344955	LEVER DETECTION (C)
1-66	ZG-312996	SP T1-4.0/0.4-14.0 T1-110
1-67	ZS-460440	PAN20x04STL CMT
1-68	ET-345091	PHOTO SENSOR SPI-201-40 B.C
1-69	ES-336990	SW LEAF BSW-169 01-1 NO
1-70	MV-666887	BALL 250STL
1-71	ET-310341	PHOTO SENSOR PT350 T
1-72	HZ-349298	PLATE HEAD HOLDER
1-73	ZS-336613	PT PAN26x06STL CMT
1-74	ZG-349033	SP ARM PINCH ROLLER (R)
1-75	ZG-349034	SP ARM PINCH ROLLER (L)
1-76	ZW-350839	NYLON NUT M3
1-77	ZW-259650	PW30x050x020PBR
1-78	ZW-270088	RING E 190SUP CMT
1-79	SP-336163	LID CASE
1-80	ZG-336615	SP PLATE CASSETTE HOLDER (B)
1-81	BD-B348464	LID DECORATION PART
1-82	ED-337010	D LED SLF201C GRN
1-83	BZ-T2030A110A	OIL CLUTCH BLK GX-F51
1-84	ZW-270088	RING E 190SUP CMT
1-85	ES-337427	SW MICRO SS-01-E
1-86	ZS-310337	PAN20x08STL CMT
1-87	MP-336204	ROLLER PINCH (B)

NOTE: Parts listed in 1 to 87 on the exploded view and parts list are normally stocked for replacement purpose.
The remaining parts shown in this manual are not normally stocked, because they are not seldom required for routine service.

MOTOR BLM-500 BLOCK

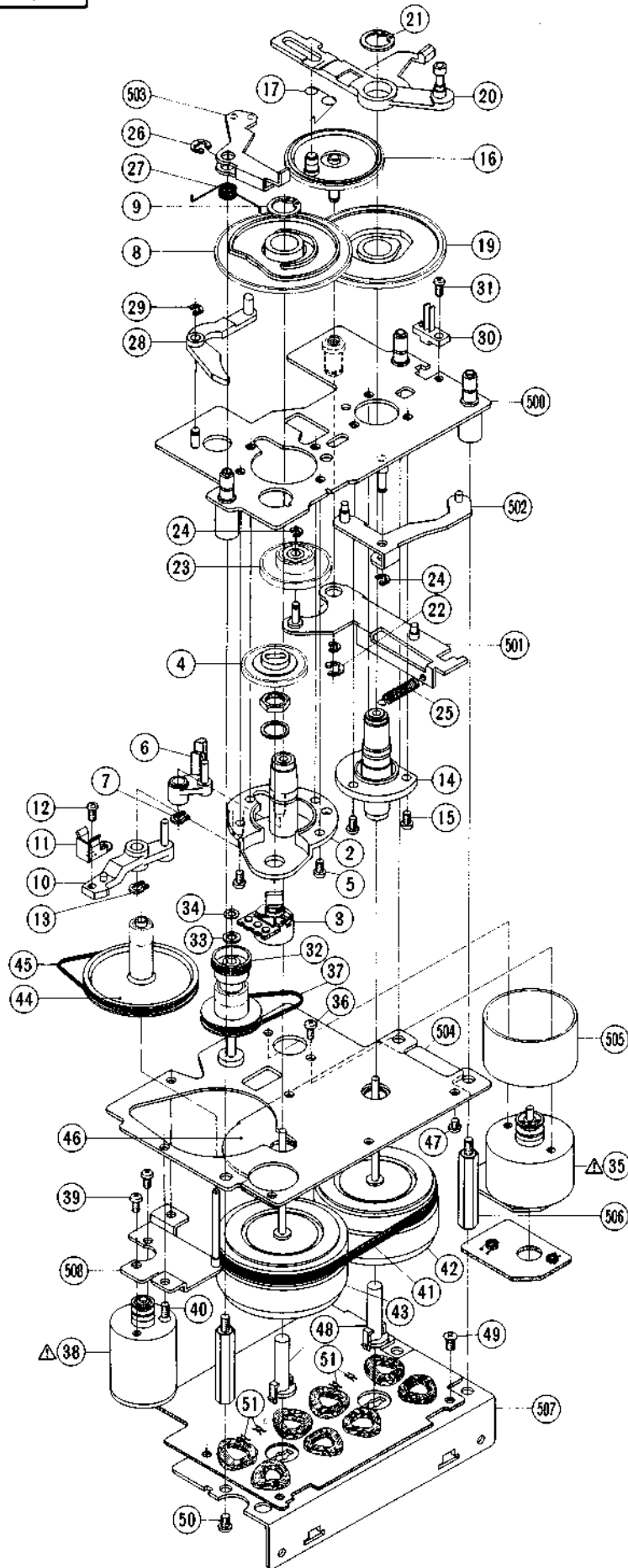

2. MOTOR BLM-500 BLOCK

REF. NO.	PARTS NO.	DESCRIPTION
2-1	BM-M3105A010A	MOTOR BLM-500
2-2	TC-B345188	HOLDER CAPSTAN (A) PART
2-3	EV-337052	VR ROTARY 16L10XOR B103
2-4	MZ-336005	GEAR POTENTION
2-5	ZS-432843	PAN26x04STL CMT
2-6	BL-B336007X1	LEVER BRAKE CAM (1) PART
2-7	ZW-336603	RING GRIP 285SUP ACP
2-8	MZ-345169	CAM WHEEL
2-9	ZW-336604	RING S930SUP ACP
2-10	BL-B336009	LEVER EJECT CAM PART
2-11	MZ-353158	SP PLATE EJECT
2-12	ZS-477876	PAN20x03STL CMT
2-13	ZW-336603	RING GRIP 285SUP ACP
2-14	TC-B345187	HOLDER CAPSTAN (B) PART
2-15	ZS-432843	PAN26x04STL CMT
2-16	MZ-B345155	GEAR REVERSE PART
2-17	ZG-349029	SP TORSION GEAR REVERSE
2-18	ZW-270088	RING E 190SUP CMT
2-19	MZ-345170	CAM WHEEL (R)
2-20	BL-B345159	LEVER REVERSE PART
2-21	ZW-336604	RING S930SUP ACP
2-22	ZW-270134	RING E500SUP CMT
2-23	MZ-345165	GEAR IDLER
2-24	ZW-270088	RING E 190SUP CMT
2-25	ZG-313002	SP T1-4.0/0.4-25.0 T1-115
2-26	ZW-270123	RING E400SUP CMT
2-27	ZG-344984	SP TORSION (R)
2-28	ML-345173	LEVER RELEASE
2-29	ZW-270088	RING E 190SUP CMT
2-30	ES-336990	SW LEAF BSW-169 01-1 NO
2-31	ZS-460440	PAN20x04STL CMT
2-32	MR-B345184	PULLEY MAIN PART
2-33	ZW-259661	PW30x050x025PSL
2-34	ZW-282407	PUSH WASHER (B)
2-35	BM-B604526	Δ REEL MOTOR PART
2-36	ZS-592378	PAN26x03STL CMT
2-37	MB-345179	BELT GEAR
2-38	BM-B604527	Δ MOTOR OPERATION PART
2-39	ZS-592378	PAN26x03STL CMT
2-40	ZS-477887	CTS26x05STL CMT
2-41	MB-345193	BELT CAPSTAN
2-42	BF-B345189	FLYWHEEL (A) PART
2-43	BF-B345190	FLYWHEEL (B) PART
2-44	MR-336019	PULLEY OPERATE
2-45	MB-344989	BELT OPERATION (B)
2-46	EA-345195	PC FG
2-47	ZS-321194	ST PAN26x05STL CMT
2-48	TC-345181	HOLDER THRUST
2-49	ZS-477887	CTS26x05STL CMT
2-50	ZS-422076	PAN30x05STL CMT
2-51	EI-336987	HALL ELEMENT DHD-H150

NOTE: Parts listed in 1 to 51 on the exploded view and parts list are normally stocked for replacement purpose.

The remaining parts shown in this manual are not normally stocked, because they are not seldom required for routine service.

3. SYSCON AND TUNING P.C BOARD BLOCK

REF. NO.	PARTS NO.	DESCRIPTION
3-1	BA-T2048A050A	PC SYCON TUNING BLK GX-R88
SYSCON AND TUNING P.C BOARD		
3-IC1	EI-349145	IC μ PD1511C-113
3-IC2	EI-345765	IC LB1292
3-IC3	EI-337228	IC M5218L0
3-IC4to6	EI-336761	IC LA6458S
3-IC7	EI-338238	IC μ PD4051BC
3-IC8	EI-347923	IC μ PD4071BC
3-IC201	EI-348108	IC μ PD1511C-134
3-IC202	EI-352232	IC M5L8049-154P-6
3-IC203	EI-348110	IC M5L8243P
3-IC204,205	EI-337008	IC LC7800
3-IC206to208	EI-337013	IC LB1290
3-IC209	EI-348111	IC LC4071B
3-IC210,211	EI-336761	IC LA6458S
3-IC212to214	EI-338171	IC LC4069UB
3-TR1	ET-200558	TR 2SA1115 E,F
3-TR2to4	ET-349081	TR 2SC3383 S,T
3-TR5	ET-328868	TR 2SD1012-V G,H
3-TR6to11	ET-349081	TR 2SC3383 S,T
3-TR12to17	ET-200505	TR 2SC2603 E,F
3-TR19	ET-308976	Δ TR 2SC1815 BL,GR
3-TR20,21	ET-310833	TR 2SC2274K E
3-TR29to35	ET-200505	TR 2SC2603 E,F
3-TR37	ET-308976	Δ TR 2SC1815 BL,GR
3-TR38,39	ET-310833	TR 2SC2274K E
3-TR43	ET-200505	TR 2SC2603 E,F
3-TR44	ET-200558	TR 2SA1115 E,F
3-TR45	ET-328868	TR 2SD1012-V G,H
3-TR46	ET-200505	TR 2SC2603 E,F
3-TR47to49	ET-350795	TR 2SC3399
3-TR54	ET-318237	Δ TR 2SB764 E,F
3-TR55	ET-322598	Δ TR 2SB632K E,F
3-TR201to206	ET-319638	TR 2SD1012-V F,G,H
3-TR207	ET-554657	TR 2SA733A P,Q
3-TR209	ET-200505	TR 2SC2603 E,F
3-TR210,211	ET-328868	TR 2SD1-12-V G,H
3-TR212,213	ET-347969	TR 2SB808-V F,G,H
3-TR214,215	ET-200505	TR 2SC2603 E,F
3-TR216	ET-200558	TR 2SA1115 E,F
3-D1	ED-346450	D ZENER H HZ6FA F10 B2
3-D2,3	ED-301911	D SILICON H DS448
3-D4,5	ED-346450	D ZENER H HZ6FA F10 B2
3-D6,7	ED-301911	D SILICON H DS448
3-D8	ED-344280	D SILICON H GMA-01-FY2 F05
3-D9,10	ED-301911	D SILICON H DS448
3-D12	ED-301911	D SILICON H DS448
3-D13to17	ED-346503	D ZENER H HZ20FA F10 2
3-D18	ED-346441	D ZENER H HZ5FA F10 B2
3-D19,20	ED-344280	D SILICON H GMA-01-FY2 F05
3-D201to204	ED-344280	D SILICON H GMA-01-FY2 F05
3-D207	ED-346440	D ZENER H HZ5FA F10 B1
3-D208	ED-301911	D SILICON H DS448
3-D209	ED-344280	D SILICON H GMA-01-FY2 F05
3-D210,211	ED-301911	D SILICON H DS448
3-D212to215	ED-346503	D ZENER H HZ20FA F10 2
3-VR1,2	EV-322416	R S-FIX H D8 3P 303
3-VR3,4	EV-330531	R S-FIX H TM8KV2-1S 3P 0.50W 503
3-VR7	EV-315413	R S-FIX H D8 3P 503
3-VR8	EV-315414	R S-FIX H D8 3P 203
3-VR9to11	EV-321637	R S-FIX H D8 3P 104
3-VR12	EV-315752	R S-FIX H D8 3P 204
3-VR201	EV-321637	R S-FIX H D8 3P 104
3-L1,2	EO-343768	COIL FIX 1 FL09H 391K
3-T1	EO-348101	COIL OSC 2 25-5060-02
3-T2	EO-348100	COIL OSC 1 25-5059-22
3-FL1	EO-315758	COIL TUN 1 100Z-431 100,00KHZ
3-FL2	EO-337055	COIL VARI 1 FE002S 10MH
3-FL3,201	EH-337380	FILTER CE KMFC-1001S 3.580MHZ
3-FL202	EH-347991	OSC CE CSA6.00MS 6MHZ

REF. NO.	PARTS NO.	DESCRIPTION
3-FL203	EH-347992	COMP C CSC300K
3-RL1	EQ-344440	RELAY SIGNAL G2V-282P 2TR 24V 12-160 8R2J
3-VC1	EC-348292	C S-FIX H ECR-BA160N11
3-FR1,2	ER-331188	Δ R FUSE ERD2FC S10 1/4W 12R0G
3-FR3,4	ER-348272	Δ R FUSE ERD2FC S10 1/4W 12R0G
3-SR1	EH-348115	COMP R RKC1/8B3 3.3K J
3-SR2	EH-348117	COMP R RKC1/8B8D 47K J
3-SR3	EH-347938	COMP R M-3744
3-SR5-1,5-2	EH-348114	COMP R RKC1/8B4 47K J
3-SR6-1,6-2	EH-348118	COMP C 05-0056
3-SR7	EH-348119	COMP C 05-0057
3-R38	ER-350688	R MF H 1/4W 222J
3-R146	ER-302157	R MF H 1/4W 512J
3-R201	ER-338235	R MF V 1/4W 1820F
3-R202	ER-347939	R MF V 1/4W 1051F
3-R203	ER-338234	R MF V 1/4W 1331F
3-R204	ER-347940	R MF V 1/4W 2151F
3-R205	ER-347941	R MF V 1/4W 3091F
3-R206	ER-338231	R MF V 1/4W 5361F
3-R208	ER-309788	R MF V 1/4W 1001F
3-C5,8	EC-300193	C EC V F05 NP SM 100M 16DC
3-C11	EC-350679	C COMP V AWS 183J 50DC
3-C13	EC-351996	C COMP V AWS 822J 50DC
3-C15	EC-350680	C COMP V AWS 123J 50DC
3-C17	EC-350679	C COMP V AWS 183J 50DC
3-C18,19	EC-346953	C COMP V AWS 512G 50DC
3-C20	EC-352006	C COMP V AWS 362J 50DC
3-C41	EC-200948	C EC V F05 NP SM 1R0M 50DC
3-C42	EC-307684	C EC V F05 NP SM R47M 50DC
3-C47	EC-348293	C PP V F10 ECQ-F 122J 630DC
3-C48	EC-328774	C STY V SNP CQFS 331J 250DC
3-C49	EC-348273	C STY V S05 CQFS 121J 250DC
3-C53	EC-201021	C STY V F05 CQF09 151J 250DC
3-C55	EC-352006	C COMP V AWS 362J 50DC
3-C57	EC-352007	C COMP V AWS 162J 50DC

REMOTE CONTROL P.C BOARD

3-J5	EJ-344282	DIN J TCS1891-01-1011 P 8P
------	-----------	----------------------------

4. PRE AMP IC P.C BOARD BLOCK

REF. NO.	PARTS NO.	DESCRIPTION
4-1	BA-T2048A080A	PC PRE AMP IC BLK GX-R88 (IC58)
PRE AMP P.C BOARD		
4-IC1	EI-349196	IC HA12058
4-IC2	EI-348701	IC M51143L
4-IC3	EI-307644	IC NJM4556D
4-IC5,6	EI-336761	IC LA6458S
4-IC7	EI-337126	IC TA7332P
4-IC8	EI-336761	IC LA6458S
4-IC9	EI-337360	IC μ PC4082C
4-IC10	EI-349196	IC HA12058
4-TR1	ET-330270	TR 2SC2320 F,G
4-TR2	ET-3321016	TR FET 2SK117 GR,BL
4-TR3	ET-307349	Δ TR 2SD794 P,Q
4-TR4	ET-330270	Δ TR 2SC2320 F,G
4-TR5	ET-350806	Δ TR 2SA1115 F,G
4-TR6	ET-330270	TR 2SC2320 F,G
4-TR7	ET-349081	TR 2SC3383 S,T
4-TR8	ET-349718	TR 2SA1392 S,T
4-TR9to11	ET-341400	TR FET 2SK170 BL,GR
4-TR12	ET-350795	TR 2SC3399
4-TR13	ET-348950	TR 2SA1345
4-TR14	ET-349081	TR 2SC3383 S,T
4-TR15	ET-348950	TR 2SA1345
4-TR16	ET-330270	TR 2SC2320 F,G
4-TR17	ET-348950	TR 2SA1345
4-TR18	ET-350795	TR 2SC3399
4-TR19to22	ET-330270	TR 2SC2320 F,G
4-TR23	ET-350795	TR 2SC3399
4-TR24	ET-348950	TR 2SA1345
4-TR25	ET-350795	TR 2SC3399
4-TR26	ET-348950	TR 2SA1345
4-TR27	ET-330270	TR 2SC2320 F,G
4-TR28	ET-337238	TR FET 2SK270 GR,BL
4-TR29	ET-349081	TR 2SC3383 S,T
4-TR30	ET-337112	TR 2SA798 F,G
4-TR31,32	ET-349080	TR 2SC3382 S,T
4-TR33	ET-349725	TR 2SA1391 S,T
4-TR34	ET-349080	Δ TR 2SC3382 S,T
4-TR35	ET-349725	Δ TR 2SA1391 S,T
4-TR36	ET-330270	TR 2SC2320 F,G
4-TR37	ET-349081	TR 2SC3383 S,T
4-D1	ED-346493	D ZENER H HZ15FA F10 2
4-D2to4	ED-344280	D SILICON H GMA-01-FY2 F05
4-D5	ED-346478	D ZENER H HZ11FA F10 B2
4-D6	ED-346633	D SILICON W03B F10 100/1.0A
4-D7to10	ED-344280	D SILICON H GMA-01-FY2 F05
4-D11,12	ED-308952	D GERMA V 1K34A-LR F07
4-D13,15	ED-344280	D SILICON H GMA-01-FY2 F05
4-D16,17	ED-200468	D SILICON V DS448-VB6
4-VR2	EV-337995	R S-FIX H RVF8P01 3P 103
4-VR3	EV-337993	R S-FIX H RVF8P01 3P 203
4-VR4	EV-345297	R S-FIX V TM8KH1-IS 3P 0.50W 101
4-VR5	EV-338588	R S-FIX H RVF8P01 3P 503
4-VR6	EV-325994	R S-FIX V H1052A 3P 0.15W 103
4-VL1	EO-331280	COIL VARI 1 46-1072-11 22MH
4-FL1	EH-336776	FILTER DB D07003K 100KHZ
4-FL2	EH-336775	FILTER DB D07001K 19KHZ
4-FL3	EO-336738	COIL TUN 1 102AZ-004 19.80KHZ
4-FL4	EH-336776	FILTER DB D07003K 100KHZ
4-FL5	EO-336738	COIL TUN 1 102AZ-004 19.80KHZ
4-FR1	ER-350808	Δ R FUSE ERQ14AJ S10 1/4W 181J
4-R108	ER-338183	R MF H 1/4W 104J
4-R111,112	ER-347958	R MF H 1/4W 272J
4-R113,114	ER-348130	R MF H F10 1/4W 47R0G
4-R116	ER-347959	R MF H 1/4W 561J
4-R117	ER-302156	R MF H 1/4W 472J
4-R121,122	ER-347957	R MF H 1/4W 133J
4-R124	ER-347957	R MF H 1/4W 133J
4-C2	EC-351992	C COMP V AWS 472J 50DC

REF. NO.	PARTS NO.	DESCRIPTION
4-C8	EC-338506	C COMP V AWS 103J 50DC
4-C9	EC-350679	C COMP V AWS 183J 50DC
4-C14	EC-351992	C COMP V AWS 472J 50DC
4-C15	EC-351993	C COMP V AWS 562J 50DC
4-C16	EC-351992	C COMP V AWS 472J 50DC
4-C20	EC-351995	C COMP V AWS 823J 50DC
4-C31to33	EC-345655	C PP V F05 PP 223J 50DC
4-C64	EC-351993	C COMP V AWS 562J 50DC
4-C65	EC-341409	C COMP V AWS 6801G 50DC
4-C70	EC-352009	C COMP V AWS 113J 50DC
4-C71	EC-351994	C COMP V AWS 152J 50DC
4-C72	EC-351997	C PP V F05 PP 121J 50DC
4-C73	EC-347471	C PP V F05 PP 471J 50DC
4-C74	EC-351997	C PP V F05 PP 121J 50DC
4-C81	EC-344486	C PP V F05 PP 391J 50DC
4-C84	EC-318314	C COMP AWS 333J 50DC
4-C85	EC338506	C COMP V AWS 103J 50DC
4-C87	EC-350679	C COMP V AWS 183J 50DC
4-C92,03	EC-351992	C COMP V AWS 472J 50DC
4-C94	EC-351993	C COMP V AWS 562J 50DC
4-C98	EC-351995	C COMP V AWS 823J 50DC
4-PJ1	EJ-351899	PIN J YKC21-5078 P 4P

HEAD PHONE P.C BOARD

4-J5	EJ-348160	PHONE J HLJ0540-040 6.3
------	-----------	-------------------------

SWITCH P.C BOARD

4-SW1	ES-348133	SW PUSH ESB-62746 3 THROW
-------	-----------	---------------------------

OUT VOLUME P.C BOARD

4-VR1	EV-337841	VR SLIDE 30P2SV0A B103
-------	-----------	------------------------

REC VOLUME P.C BOARD

4-VR7	EV-337840	VR SLIDE 100P2WV0A A503
-------	-----------	-------------------------

5. METER P.C BOARD BLOCK

REF. NO.	PARTS NO.	DESCRIPTION
5-1	BA-T2048A060A	PC METER BLK GX-R88
METER P.C BOARD		
5-IC1to4	EI-348105	IC HA12010
5-D1,2	ED-348121	D LED TLG143 GRN
5-D3,4	ED-348122	D LED TLY143 YLW
5-SW1,2	ES-346260	SW PUSH SPH121A 2-02-02N
5-SW3to20	ES-336780	SW TACT KHH10902
5-IN1	EM-347978	IND FL BG-167Z
5-R1	ER-346175	R MF H F10 1/4W 2001F
5-R2	ER-349158	R MF H F10 1/4W 3001F

6. POWER SUPPLY P.C BOARD BLOCK

REF. NO.	PARTS NO.	DESCRIPTION
6-1U	BA-T2048A030A	PC POWER BLK GX-R88 (U)
6-1J	BA-T2048A030B	PC POWER BLK GX-R88 (J)
6-1C	BA-T2048A030C	PC POWER BLK GX-R88 (C,A)
6-1E	BA-T2048A030D	PC POWER BLK GX-R88 (E,V,B,S)
POWER SUPPLY P.C BOARD		
6-1C1	EI-348123	IC M5230AL
6-1C2	EI-337529	Δ IC TA78L005AP
6-1C4	EI-330352	IC BA6109
6-TR1	ET-337188	Δ TR 2SB774 P,Q
6-TR2	ET-307349	Δ TR 2SD794 P,Q
6-TR3	ET-328578	Δ TR 2SC2320 E,F
6-TR4	ET-337968	TR 2SA999 E,F
6-TR5	ET-350816	Δ TR 2SD549 E,F
6-TR6	ET-322598	Δ TR 2SB632K E,F
6-TR7	ET-200505	Δ TR 2SC2603 E,F
6-TR8	ET-200505	TR 2SC2603 E,F
6-TR9	ET-554657	TR 2SA733A P,Q
6-TR10	ET-350948	Δ TR 2SD612K F
6-TR11,12	ET-336997	TR 2SB808-V G,H
6-TR13,14	ET-347961	Δ TR 2SD1012-V G
6-TR15,16	ET-336997	TR 2SB808-V G,H
6-TR17	ET-200505	TR 2SC2603 E,F
6-TR18	ET-328868	TR 2SD1012-V G,H
6-TR19	ET-200985	TR 2SC2603 F,G
6-TR20	ET-200505	TR 2SC2603 E,F
6-D1	ED-330987	Δ D SILICON RB152 200/1.5A
6-D2,3	ED-33-319	Δ D SILICON DBA10B 100/1.0A
6-D4	ED-330622	Δ D SILICON 1SR35-100VL 100/1.0A
6-D5	ED-346505	D ZENER H HZ22FA F10 1
6-D6	ED-346454	D ZENER H HZ6FA F10 C3
6-D7,8	ED-624903	D SILICON H 1S2473
6-D9	ED-346473	D ZENER H HZ9FA F10 C3
6-D11	ED-624903	D SILICON H 1S2473
6-D12	ED-346462	D ZENER H HZ7FA F10 C2
6-D13	ED-346452	D ZENER H HZ6FA F10 C1
6-D14	ED-346446	D ZENER H HZ5FA F10 C3
6-D15to18	ED-330622	D SILICON 1SR35-100VL 100/1.0A
6-VR1	EV-336851	R S-FIX H KVSF807V 3P 501
6-SW1	ES-348998	Δ SW PUSH SDL1P 01-1
6-FR1	ER-318248	Δ R FUSE ERD2FC S10 1/4W 47R0G
6-R1,2	ER-347952	Δ R OMF H S15 FS 1W 331J
6-R11	ER-352000	R OMF H S15 FS 1W 332J
6-R38	ER-337755	R OMF H S20 FS 2W 222J
6-C1,2	EC-324664	C EC V CUT USM 222M 25.0DC
6-C4	EC-352001	C STY V CUT CQ09S2B 471J 125DC
6-C16	EC-201761	C EC V CUT USM 472M 16.0DC
6-C24	EC-316186	C EC V CUT SM 222M 16.0DC
6-C30U	EC-337681	Δ C MMY V ECQEW 223M 250AC (U)
6-C30J	EC-350949	Δ C MMY V ECQ-E 223M 250DC (J)
6-C30C	EC-338397	Δ C MMY V ECQUE 223M 125AC (C,A)
6-C30W	EC-338399	Δ C MMY V ECQF 223M 250AC (E,V,B,S)
6-F1Uto3U	EF-309387	Δ FUSE TSC A 250V 1.00A(U,J)
6-F4U	EF-311839	Δ FUSE TSC A 250V 1.60A(U,J)
6-F5J	EF-306124	Δ FUSE TSC A 250V 0.63A (J)
6-F1Cto3C	EF-310229	Δ FUSE TSC 125V 1.00A (C,A)
6-F4C	EF-308847	Δ FUSE TSC 125V 1.60A (C,A)
6-F5C	EF-305703	Δ FUSE TSC 125V 0.63A (C,A)
6-F1Eto3E	EF-623103	Δ FUSE SEMKO T 250V 1.00A (E,V,B,S)
6-F4E	EF-601964	Δ FUSE SEMKO T 250V 1.60A (E,V,B,S)
6-F5E	EF-601942	Δ FUSE SEMKO T 250V 0.63A (E,V,B,S)

7. MOTOR P.C BOARD BLOCK

REF. NO.	PARTS NO.	DESCRIPTION
MOTOR P.C BOARD		
7-1C1A,2A	EI-201940	IC NJM4558S
7-TR1A	ET-337011	TR 2SC2274K D,E
7-TR2A	ET-337012	TR 2SA984K D,E
7-TR3A	ET-337011	TR 2SC2274K D,E
7-TR4A	ET-337012	TR 2SA984K D,E
SERVO P.C BOARD		
7-1C1B	EI-336992	IC μPC1043C
7-1C2B	EI-310036	IC TC4066BP
7-1C3B	EI-201940	IC NJM4558S
7-TR1B	ET-200505	TR 2SC2603 E,F
7-TR2B	ET-337011	TR 2SC2274K D,E
7-TR3B	ET-337012	TR 2SA984K D,E
7-TR4B	ET-337011	TR 2SC2274K D,E
7-TR5B	ET-337012	TR 2SA984K D,E
7-D1Bto4B	ED-348001	D ZENER V HZ2B-1S7
7-D5B	ED-338082	D ZENER V HZ5C-1S7
7-VR1B	EV-341250	R S-FIX V TM8KH1-1S 3P 0.50W 503
7-VR2B,3B	EV-336850	R S-FIX H KVSF807U 3P 202
7-R5B	ER-323487	R MF H F10 1/4W 1503F
7-R22B	ER-333703	R CB H S15 FS RDS 1/2W 911J
7-C4B	EC-347590	C COMP V AWS 273J 50DC

ASSEMBLY BLOCK

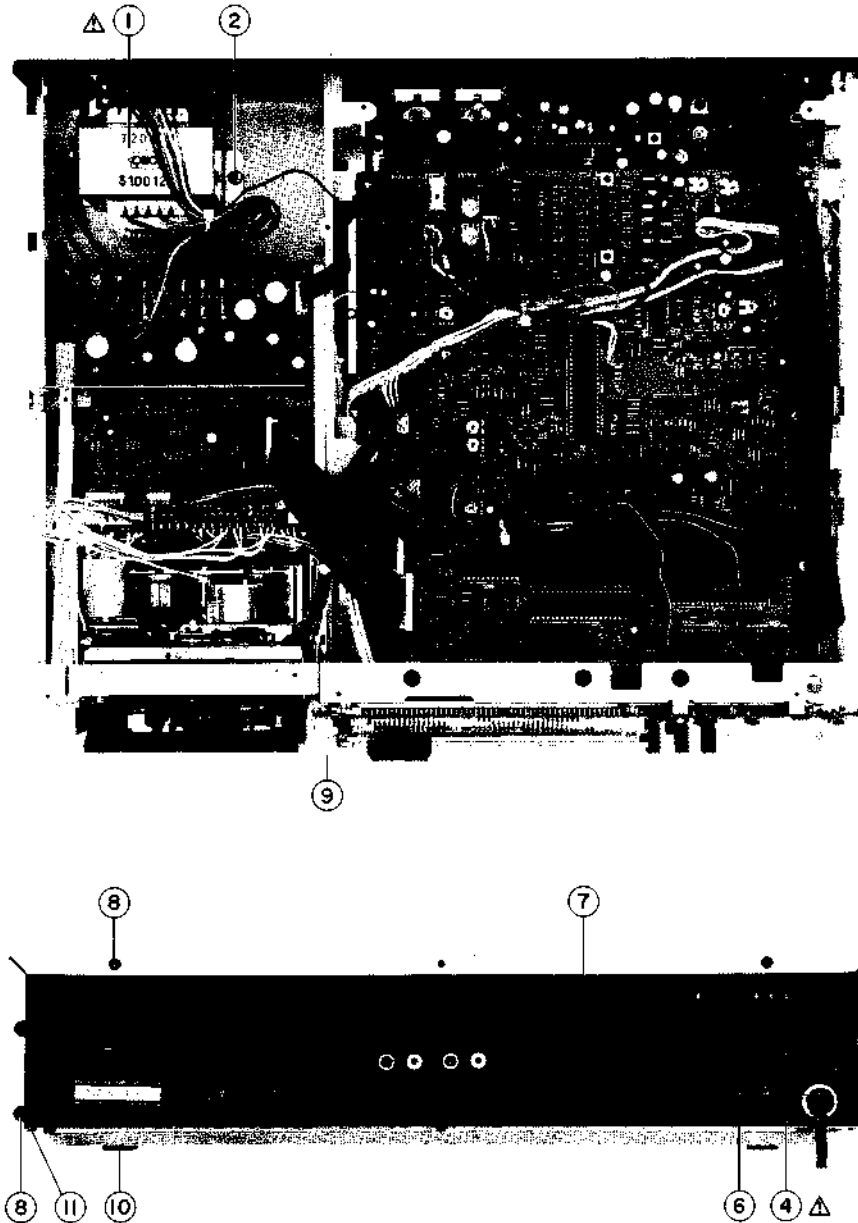

8. ASSEMBLY BLOCK

REF. NO.	PARTS NO.	DESCRIPTION	REF. NO.	PARTS NO.	DESCRIPTION
TRANS POWER BLOCK			8-5Ux	ES-305733	△ SW SELECTOR HXW0131-260 01-4 (U)
8-1U	BT-347970	△ TRANS POWER T2048U	8-6U	EZ-631945	STRAIN RELIEF SR-4N-4 (U,J,C,A,E,V,S)
8-1J	BT-347971	△ TRANS POWER T2048J	8-6B	EJ-692908	STRAIN RELEIF SR-5N-4 (B)
8-1A	BT-347972	△ TRANS POWER T2048AC	ASSEMBLY BLOCK		
8-1E	BT-347973	△ TRANS POWER T2048EV	8-7U	SP-345237G	PANEL REAR GX-R88(U)
8-1B	BT-347974	△ TRANS POWER T2048BS	8-7J	SP-345237H	PANEL REAR GX-R88 (J)
8-2	ZS-301398	ST BID40x08STL CMT	8-7C	SP-345237J	PANEL REAR GX-R88 (C,A)
8-3x	ZW-413188	N40STL CMT 1	8-7E	SP-345237L	PANEL REAR GX-R88 (E)
8-4U	EW-374894	AC CORD 2 CORES VM-0129A,VFF U/T (U)	8-7V	SP-345237N	PANEL REAR GX-R88 (V)
8-4J	Ew-351961	AC CORD 2 CORES KP-211 VFF J (J)	8-7B	SP-345237M	PANEL REAR GX-R88 (B,S)
8-4C	EW-207742	AC CORD 2 CORES VM-0238, SPT-1 UC (C,A)	8-8	ZS-345272	ST BR30x06STL BNI
8-4E	EW-347897	AC CORD 2 CORES VM0364,LCFL EV (E,V)	8-9	ZG-350793	SP EARTH
8-4B	EW-347828	AC NR BS 42/0.15x2 EV (B)	8-10	SA-349332	FOOT
8-4S	EW-347898	AC CORD 2 CORES VM-0436, LCFL S (S)	8-11	ZS-320906	ST BR30x06STL CMT
			8-12x	ZW-305013	RV POP32 (A)

FINAL ASSEMBLY BLOCK

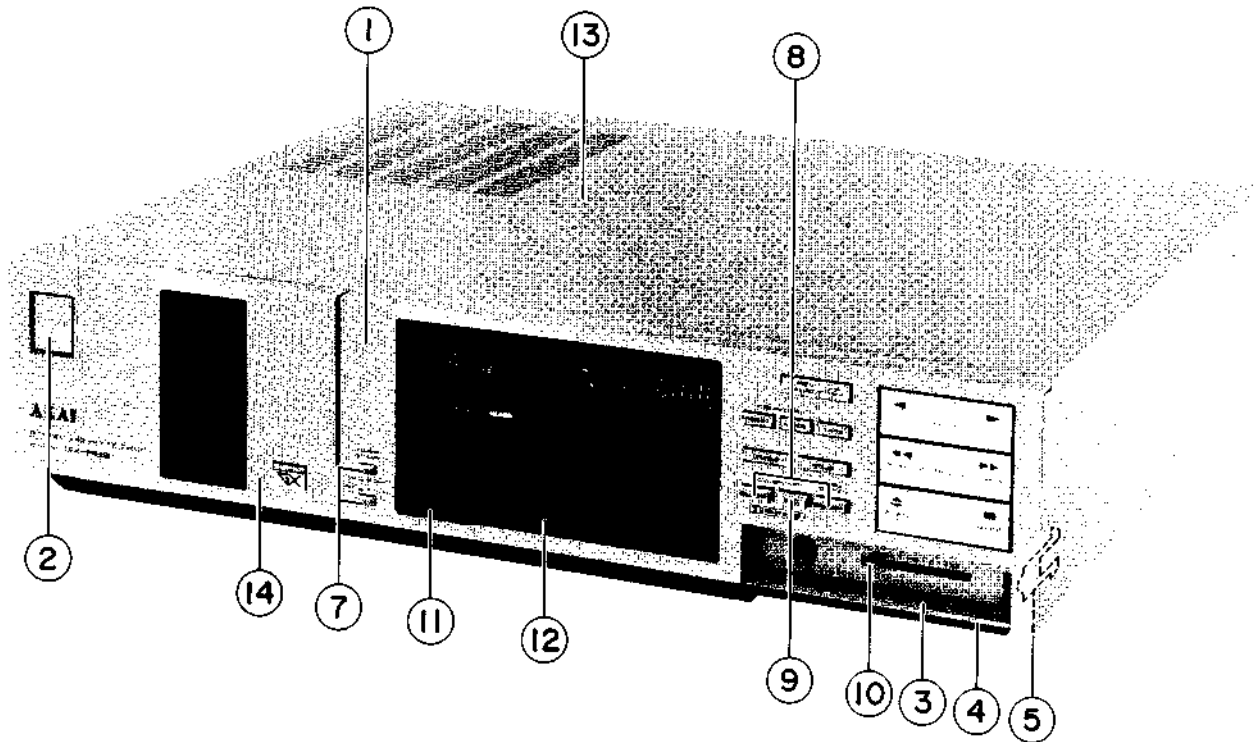

9. FINAL ASSEMBLY BLOCK

REF. NO.	PARTS NO.	DESCRIPTION
9-1S	BD-T2048A070A	PANEL FRONT BLK GX-R88
9-1P	BD-T2048A070B	PANEL FRONT BLK GX-R88-P
9-1B	BD-T2048A070C	PANEL FRONT BLK GX-R88-B
9-2S	SK-B345231A	KNOB POWER PART
9-2P	SK-B345231B	KNOB POWER-P PART
9-2B	SK-B345231C	KNOB POWER-B PART
9-3	SP-345228B	DOOR PHONE-P
9-3B	SP-345228C	DOOR PHONE-B
9-4S	SP-345226A	PANEL PHONE
9-4P	SP-345226B	PANEL PHONE-P
9-4B	SP-345226C	PANEL PHONE-B
9-5	TP-345229	HINGE DOOR
9-6S	MB-330911	CUSHION RUBBER
9-6P	MB-330911B	CUSHION RUBBER (BL)
9-7S	SK-351574A	KNOB TIMER
9-7P	SK-351574B	KNOB TIMER-P
9-7B	SK-351574C	KNOB TIMER-B
9-8S	SK-B345233A1	KNOB DOLBY-1 PART
9-8P	SK-B345233A3	KNOB DOLBY-1P PART
9-8B	SK-B345233A4	KNOB DOLBY-1B PART
9-9S	SK-B345233A2	KNOB DOLBY-2 PART

REF. NO.	PARTS NO.	DESCRIPTION
9-9P	SK-B345233A5	KNOB DOLBY-2P PART
9-9B	SK-B345233A6	KNOB DOLBY-2B PART
9-10S	SK-343009D	KNOB OUTPUT-S
9-10P	SK-343009B	KNOB OUTPUT-P
9-10B	SK-343009C	KNOB OUTPUT-B
9-11,11B	SK-B345271	KNOB REC PART
9-12	TP-345269	SCALE
9-13S	BC-345243A	COVER UPPER
9-13P	BC-345243B	COVER UPPER-P
9-13B	BC-345243C	COVER UPPER-B
9-14S	BD-B345247D	LID PANEL GX-R88 PART
9-14P	BD-B345247E	LID PANEL GX-R88-P PART
9-14B	BD-B345247F	LID PANEL GX-R88-B PART

SYMBOL FOR COLOR VARIATION

S - SILVER
P - PEARL SHADOW
B - BLACK

INDEX

PARTS NO.	REF. NO.	PART NO.	REF. NO.	PARTS NO.	REF. NO.	PARTS NO.	REF. NO.
BA-T2048A030A	6-1U	EC-351995	4-C20	ED-348122	5-D3	EJ-348160	4-J5
BA-T2048A030B	6-1J	EC-351995	4-C98	ED-348122	5-D4	EJ-351899	4-P11
BA-T2048A030C	6-1C	EC-351996	3-C13	ED-624903	6-D8	EJ-692908	8-6B
BA-T2048A030D	6-1E	EC-351997	4-C72	ED-624903	6-D7	EM-347978	5-IN1
BA-T2048A050A	3-1	EC-351997	4-C74	ED-624903	6-D11	EO-315758	3-FL1
BA-T2048A060A	5-1	EC-352001	6-C4	EF-305703	6-F5C	EO-331280	4-VL1
BA-T2048A080A	4-1	EC-352006	3-C20	EF-306124	6-F5J	EO-336738	4-FL3
BC-345243A	9-13S	EC-352006	3-C55	EF-308847	6-F4C	EO-336738	4-FL5
BC-345243B	9-13P	EC-352007	3-C57	EF-309387	6-F3U	EO-337055	3-FL2
BC-345243C	9-13B	EC-352009	4-C70	EF-309387	6-F2U	EO-343768	3-L1
BD-B345247D	9-14S	ED-200468	4-D16	EF-309387	6-F1U	EO-343768	3-L2
BD-B345247E	9-14P	ED-200468	4-D17	EF-310229	6-F2C	EO-348100	3-T2
BD-B345247F	9-14B	ED-301911	3-D2	EF-310229	6-F3C	EO-348101	3-T1
BD-B348464	1-81	ED-301911	3-D3	EF-310229	6-F1C	EQ-344440	3-RL1
BD-T2048A070A	9-1S	ED-301911	3-D10	EF-311839	6-F4U	ER-302156	4-R117
BD-T2048A070B	9-1P	ED-301911	3-D6	EF-601942	6-F5E	ER-302157	3-R146
BD-T2048A070C	9-1B	ED-301911	3-D12	EF-601964	6-F4E	ER-309788	3-R208
BF-B345189	2-42	ED-301911	3-D7	EF-623103	6-F1E	ER-318248	6-FR1
BF-B345190	2-43	ED-301911	3-D9	EF-623103	6-F2E	ER-323487	7-R5B
BH-T2049A070A	1-2	ED-301911	3-D208	EF-623103	6-F3E	ER-331188	3-FR1
BL-B336007X1	2-6	ED-301911	3-D210	EH-336775	4-FL2	ER-331188	3-FR2
BL-B336009	2-10	ED-301911	3-D211	EH-336776	4-FL1	ER-333703	7-R22B
BL-B345159	2-20	ED-308952	4-D11	EH-336776	4-FL4	ER-337755	6-R38
BL-T2049A050A	1-27	ED-308952	4-D12	EH-337380	3-FL3	ER-338183	4-R108
BL-T2049A060A	1-32	ED-330319	6-D3	EH-337380	3-FL201	ER-338231	3-R206
BM-B604526	2-35	ED-330319	6-D2	EH-347938	3-SR3	ER-338234	3-R203
BM-B604527	2-38	ED-330622	6-D4	EH-347991	3-FL202	ER-338235	3-R201
BM-M3105A010A	2-1	ED-330622	6-D18	EH-347992	3-FL203	ER-346175	5-R1
BR-T2049A040A	1-26	ED-330622	6-D16	EH-348114	3-SR5-1	ER-347939	3-R202
BT-347970	8-1U	ED-330622	6-D17	EH-348114	3-SR5-2	ER-347940	3-R204
BT-347971	8-1J	ED-330622	6-D15	EH-348115	3-SR1	ER-347941	3-R205
BT-347972	8-1A	ED-330987	6-D1	EH-348117	3-SR2	ER-347952	6-R2
BT-347973	8-1E	ED-337010	1-82	EH-348118	3-SR6-1	ER-347952	6-R1
BT-347974	8-1B	ED-338082	7-D5B	EH-348118	3-SR6-2	ER-347957	4-R122
BZ-T2030A110A	1-83	ED-344280	3-D204	EH-348119	3-SR7	ER-347957	4-R121
BZ-T2049A020A	1-1	ED-344280	3-D209	EI-201940	7-IC1A	ER-347957	4-R124
EA-345195	2-46	ED-344280	3-D202	EI-201940	7-IC2A	ER-347958	4-R111
EC-200948	3-C41	ED-344280	3-D8	EI-201940	7-IC3B	ER-347958	4-R112
EC-201021	3-C53	ED-344280	3-D19	EI-307644	4-IC3	ER-347959	4-R116
EC-201761	6-C16	ED-344280	3-D20	EI-310036	7-IC2B	ER-348130	4-R113
EC-300193	3-C8	ED-344280	3-D201	EI-330352	6-IC4	ER-348130	4-R114
EC-300193	3-C5	ED-344280	3-D203	EI-336761	3-IC6	ER-348272	3-FR3
EC-307684	3-C42	ED-344280	4-D2	EI-336761	3-IC4	ER-348272	3-FR4
EC-316186	6-C24	ED-344280	4-D3	EI-336761	3-IC5	ER-349158	5-R2
EC-318314	4-C84	ED-344280	4-D4	EI-336761	3-IC210	ER-350688	3-R38
EC-324664	6-C2	ED-344280	4-D7	EI-336761	3-IC211	ER-350808	4-FR1
EC-324664	6-C1	ED-344280	4-D9	EI-336761	4-IC5	ER-352000	6-R11
EC-328774	3-C48	ED-344280	4-D10	EI-336761	4-IC6	ES-305733	8-5UX
EC-337681	6-C30U	ED-344280	4-D13	EI-336761	4-IC8	ES-336780	5-SW10
EC-338397	6-C30C	ED-344280	4-D8	EI-336987	2-51	ES-336780	5-SW14
EC-338399	6-C30E	ED-344280	4-D15	EI-336992	7-IC1B	ES-336780	5-SW3
EC-338506	4-C8	ED-346440	3-D207	EI-337008	3-IC204	ES-336780	5-SW4
EC-338506	4-C85	ED-346441	3-D18	EI-337008	3-IC205	ES-336780	5-SW5
EC-341409	4-C65	ED-346446	6-D14	EI-337013	3-IC208	ES-336780	5-SW6
EC-344486	4-C81	ED-346450	3-D1	EI-337013	3-IC206	ES-336780	5-SW7
EC-345655	4-C31	ED-346450	3-D4	EI-337013	3-IC207	ES-336780	5-SW8
EC-345655	4-C32	ED-346450	3-D5	EI-337126	4-IC7	ES-336780	5-SW9
EC-345655	4-C33	ED-346452	6-D13	EI-337228	3-IC3	ES-336780	5-SW11
EC-346953	3-C18	ED-346454	6-D6	EI-337360	4-IC9	ES-336780	5-SW12
EC-346953	3-C19	ED-346462	6-D12	EI-337529	6-IC2	ES-336780	5-SW13
EC-347471	4-C73	ED-346473	6-D9	EI-338171	3-IC212	ES-336780	5-SW15
EC-347590	7-C4B	ED-346478	4-D5	EI-338171	3-IC213	ES-336780	5-SW16
EC-348273	3-C49	ED-346493	4-D1	EI-338171	3-IC214	ES-336780	5-SW17
EC-348292	3-VC1	ED-346503	3-D13	EI-338238	3-IC7	ES-336780	5-SW19
EC-348293	3-C47	ED-346503	3-D15	EI-345765	3-IC2	ES-336780	5-SW20
EC-350679	3-C11	ED-346503	3-D16	EI-347923	3-IC8	ES-336780	5-SW18
EC-350679	3-C17	ED-346503	3-D17	EI-348105	5-IC1	ES-336990	169
EC-350679	4-C9	ED-346503	3-D14	EI-348105	5-IC2	ES-336990	230
EC-350679	4-C87	ED-346503	3-D212	EI-348105	5-IC3	ES-337427	185
EC-350680	3-C15	ED-346503	3-D213	EI-348105	5-IC4	ES-344253	162
EC-350949	6-C30J	ED-346503	3-D214	EI-348108	3-IC201	ES-344253	164
EC-351992	4-C2	ED-346503	3-D215	EI-348110	3-IC203	ES-344257	161
EC-351992	4-C14	ED-346505	6-D5	EI-348111	3-IC209	ES-344257	163
EC-351992	4-C16	ED-346633	4-D6	EI-348123	6-IC1	ES-346260	5-SW1
EC-351992	4-C92	ED-348001	7-D1B	EI-348701	4-IC2	ES-346260	5-SW2
EC-351992	4-C93	ED-348001	7-D2B	EI-349145	3-IC1	ES-348133	4-SW1
EC-351993	4-C15	ED-348001	7-D4B	EI-349196	4-IC1	ES-348998	6-SW1
EC-351993	4-C64	ED-348001	7-D3B	EI-349196	4-IC10	ET-200505	3TR13
EC-351993	4-C94	ED-348121	5-D1	EI-352232	3-IC202	ET-200505	3TR14
EC-351994	4-C71	ED-348121	5-D2	EJ-344282	3-J5	ET-200505	3TR16

INDEX

PARTS NO.	REF. NO.	PARTS NO.	REF. NO.	PARTS NO.	REF. NO.	PARTS NO.	REF. NO.
ET-200505	3-TR12	ET-347961	6-TR14	MB-344989	2-45	ZG-344988	1-19
ET-200505	3-TR15	ET-347969	3-TR212	MB-345179	2-37	ZG-349029	2-17
ET-200505	3-TR17	ET-347969	3-TR213	MB-345193	2-41	ZG-349030	1-29
ET-200505	3-TR29	ET-348950	4-TR26	MI-T2049A030A	1-25	ZG-349033	1-74
ET-200505	3-TR30	ET-348950	4-TR13	ML-B344951	1-38	ZG-349034	1-75
ET-200505	3-TR31	ET-348950	4-TR15	ML-B344952	1-40	ZG-349177	1-41
ET-200505	3-TR32	ET-348950	4-TR17	ML-B344962	1-48	ZG-349178	1-31
ET-200505	3-TR34	ET-348950	4-TR24	ML-344949	1-34	ZG-350793	8-9
ET-200505	3-TR33	ET-349080	4-TR31	ML-344950	1-36	ZG-351688	1-12
ET-200505	3-TR35	ET-349080	4-TR32	ML-344953	1-59	ZS-245147	1-7
ET-200505	3-TR43	ET-349080	4-TR34	ML-344954	1-60	ZS-301398	8-2
ET-200505	3-TR46	ET-349081	3-TR2	ML-344955	1-65	ZS-310337	1-86
ET-200505	3-TR209	ET-349081	3-TR4	ML-344961	1-47	ZS-320906	8-11
ET-200505	3-TR215	ET-349081	3-TR3	ML-345073	1-44	ZS-321194	2-47
ET-200505	3-TR214	ET-349081	3-TR6	ML-345074	1-46	ZS-336613	1-73
ET-200505	6-TR8	ET-349081	3-TR7	ML-345173	2-28	ZS-344001	1-9
ET-200505	6-TR7	ET-349081	3-TR8	MP-336204	1-87	ZS-345272	8-8
ET-200505	6-TR20	ET-349081	3-TR9	MP-344980	1-28	ZS-345773	1-23
ET-200505	6-TR17	ET-349081	3-TR10	MR-B345184	2-32	ZS-422076	2-50
ET-200505	7-TR1B	ET-349081	3-TR11	MR-336019	2-44	ZS-432843	2-5
ET-200558	3-TR1	ET-349081	4-TR7	MT-305793	1-55	ZS-432843	2-15
ET-200558	3-TR44	ET-349081	4-TR14	MV-666887	1-70	ZS-460440	1-67
ET-200558	3-TR216	ET-349081	4-TR29	MZ-B345155	2-16	ZS-460440	2-31
ET-200985	6-TR19	ET-349081	4-TR37	MZ-336005	2-4	ZS-477876	2-12
ET-307349	4-TR3	ET-349718	4-TR8	MZ-344004	1-11	ZS-477887	2-40
ET-307349	6-TR2	ET-349725	4-TR33	MZ-345165	2-23	ZS-477887	2-49
ET-308976	3-TR19	ET-349725	4-TR35	MZ-345169	2-8	ZS-481645	1-18
ET-308976	3-TR37	ET-350795	3-TR47	MZ-345170	2-19	ZS-524812	1-24
ET-310341	1-71	ET-350795	3-TR48	MZ-353158	2-11	ZS-592378	2-39
ET-310833	3-TR21	ET-350795	3-TR49	SA-349332	8-10	ZS-592378	2-36
ET-310833	3-TR20	ET-350795	4-TR12	SK-B345231A	9-2S	ZW-259650	1-77
ET-310833	3-TR38	ET-350795	4-TR18	SK-B345231B	9-2P	ZW-259661	2-33
ET-310833	3-TR39	ET-350795	4-TR23	SK-B345231C	9-2B	ZW-270088	1-78
ET-318237	3-TR54	ET-350795	4-TR25	SK-B345233A1	9-8S	ZW-270088	1-84
ET-319638	3-TR204	ET-350806	4-TR5	SK-B345233A2	9-9S	ZW-270088	2-18
ET-319638	3-TR201	ET-350816	6-TR5	SK-B345233A3	9-8P	ZW-270088	2-24
ET-319638	3-TR202	ET-350948	6-TR10	SK-B345233A4	9-8B	ZW-270088	2-29
ET-319638	3-TR203	ET-554657	3-TR207	SK-B345233A5	9-9P	ZW-270123	2-26
ET-319638	3-TR205	ET-554657	6-TR9	SK-B345233A6	9-9B	ZW-270134	2-22
ET-319638	3-TR206	EV-315413	3-VR7	SK-B345271	9-11B	ZW-273734	1-10
ET-321016	4-TR2	EV-315414	3-VR8	SK-B345271	9-11	ZW-282407	2-34
ET-322598	3-TR55	EV-315752	3-VR12	SK-343009B	9-10P	ZW-305013	8-12x
ET-322598	6-TR6	EV-321637	3-VR9	SK-343009C	9-10B	ZW-329422	1-45
ET-328578	6-TR3	EV-321637	3-VR10	SK-343009D	9-10S	ZW-329422	1-50
ET-328868	3-TR5	EV-321637	3-VR11	SK-351574A	9-7S	ZW-329422	1-57
ET-328868	3-TR45	EV-321637	3-VR201	SK-351574B	9-7P	ZW-330073	1-54
ET-328868	3-TR210	EV-322416	3-VR1	SK-351574C	9-7B	ZW-336603	2-7
ET-328868	3-TR211	EV-322416	3-VR2	SP-336163	1-79	ZW-336603	2-13
ET-328868	6-TR18	EV-325994	4-VR6	SP-345226A	9-4S	Zw-336604	2-21
ET-330270	4-TR1	EV-330531	3-VR3	SP-345226B	9-4P	ZW-336604	2-9
ET-330270	4-TR4	EV-330531	3-VR4	SP-345226C	9-4B	ZW-344639G	1-21
ET-330270	4-TR6	EV-336850	7-VR2B	SP-345228B	9-3	ZW-344639H	1-21
ET-330270	4-TR16	EV-336850	7-VR3B	SP-345228C	9-3B	ZW-344639J	1-21
ET-330270	4-TR19	EV-336851	6-VR1	SP-345237G	8-7U	ZW-350766B	1-20
ET-330270	4-TR20	EV-337052	2-3	SP-345237H	8-7J	ZW-350766C	1-20
ET-330270	4-TR21	EV-337840	4-VR7	SP-345237I	8-7C	ZW-350766D	1-20
ET-330270	4-TR22	EV-337841	4-VR1	SP-345237L	8-7E	ZW-350839	1-76
ET-330270	4-TR27	EV-337993	4-VR3	SP-345237M	8-7B	ZW-350890	1-30
ET-330270	4-TR36	EV-337995	4-VR2	SP-345237N	8-7V	ZW-356657	1-43
ET-336997	6-TR16	EV-338588	4-VR5	SZ-336166	1-33	ZW-391397	1-13
ET-336997	6-TR11	EV-341250	7-VR1B	TC-B345187	2-14	ZW-413188	8-3x
ET-336997	6-TR12	EV-345297	4-VR4	TC-B345188	2-2	ZW-618884	1-16
ET-336997	6-TR15	EW-207742	8-4C	TC-336142	1-53		
ET-337011	7-TR4B	EW-347828	8-4B	TC-336146	1-35		
ET-337011	7-TR2B	EW-347897	8-4E	TC-336161	1-56		
ET-337011	7-TR1A	EW-347898	8-4S	TC-344942	1-17		
ET-337011	7-TR3A	EW-351961	8-4J	TC-344982	1-58		
ET-337012	7-TR5B	EW-374894	8-4U	TC-345181	2-48		
ET-337012	7-TR3B	EZ-631945	8-6U	TP-345229	9-5		
ET-337012	7-TR4A	HE-H2302A010A	1-14	TP-345269	9-12		
ET-337012	7-TR2A	HE-H2303A010A	1-15	ZG-312946	1-37		
ET-337112	4-TR30	HP-H2404A010A	1-5	ZG-312996	1-66		
ET-337188	6-TR1	HZ-B344006	1-6	ZG-313002	2-25		
ET-337234	4-TR28	HZ-B344009	1-4	ZG-336141	1-52		
ET-337968	6-TR4	HZ-344011	1-8	ZG-336615	1-80		
ET-341400	4-TR9	HZ-344015	1-22	ZG-344960	1-51		
ET-341400	4-TR10	HZ-349298	1-72	ZG-344964	1-49		
ET-341400	4-TR11	MA-B344940	1-3	ZG-344984	2-27		
ET-345091	1-68	MB-330911	9-6S	ZG-344985	1-42		
ET-347961	6-TR13	MB-330911B	9-6P	ZG-344987	1-39		

AKAI

MODEL GX-R88

**P.C BOARDS
SCHEMATIC DIAGRAM**

BA6109

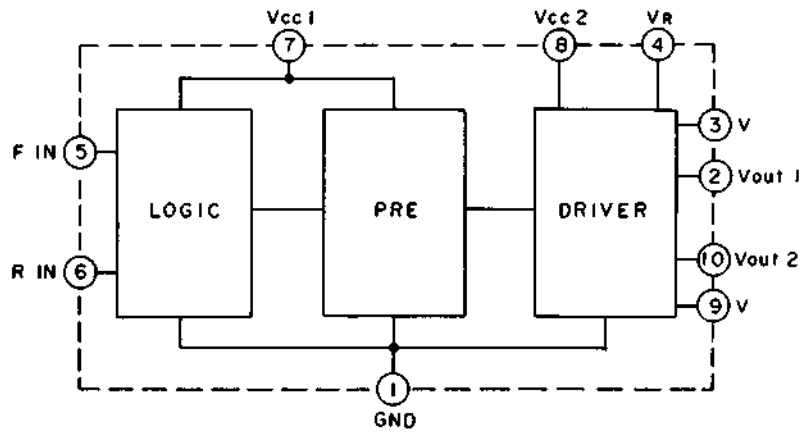

HA12010

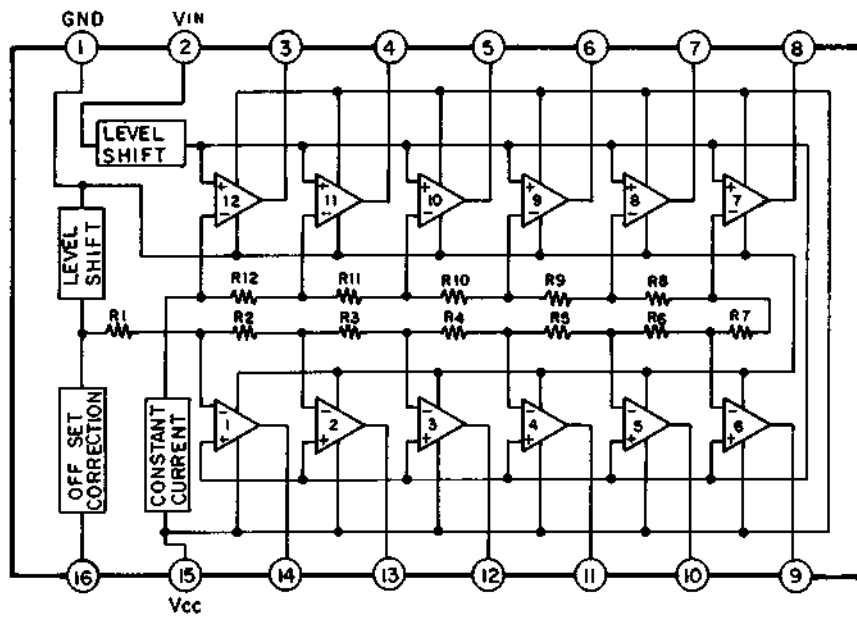

M5L8243P

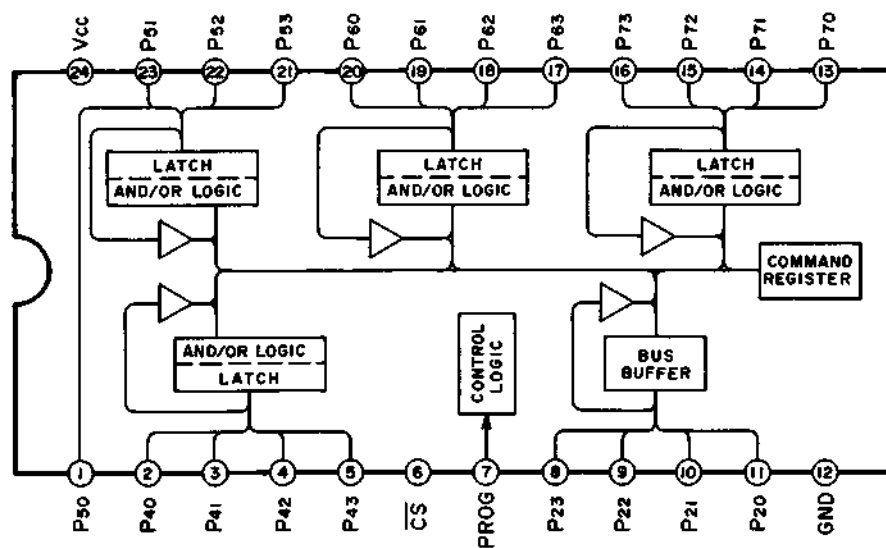

M5230AL

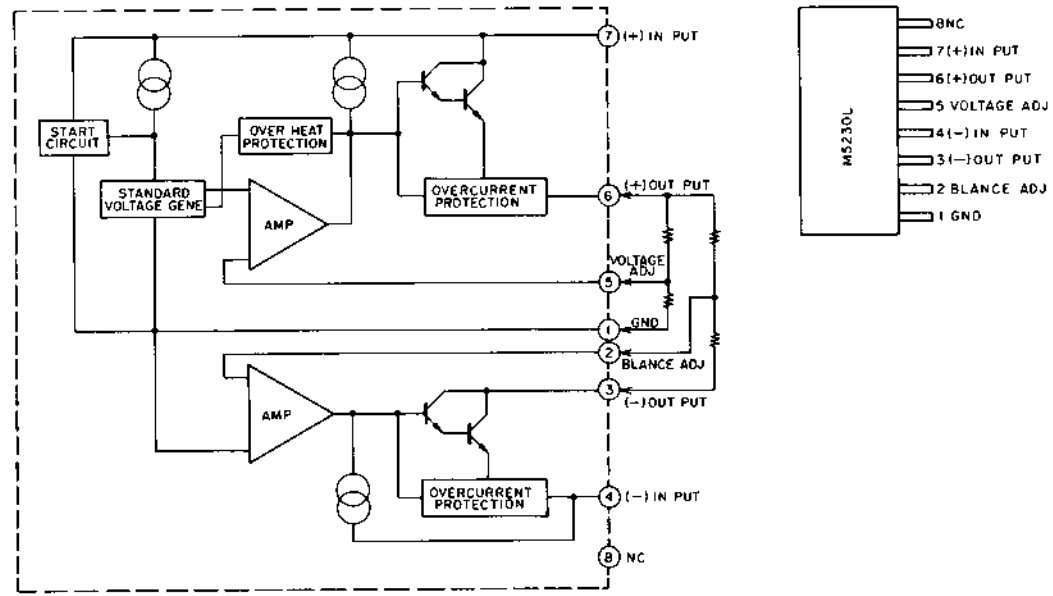

μ PD4051BC

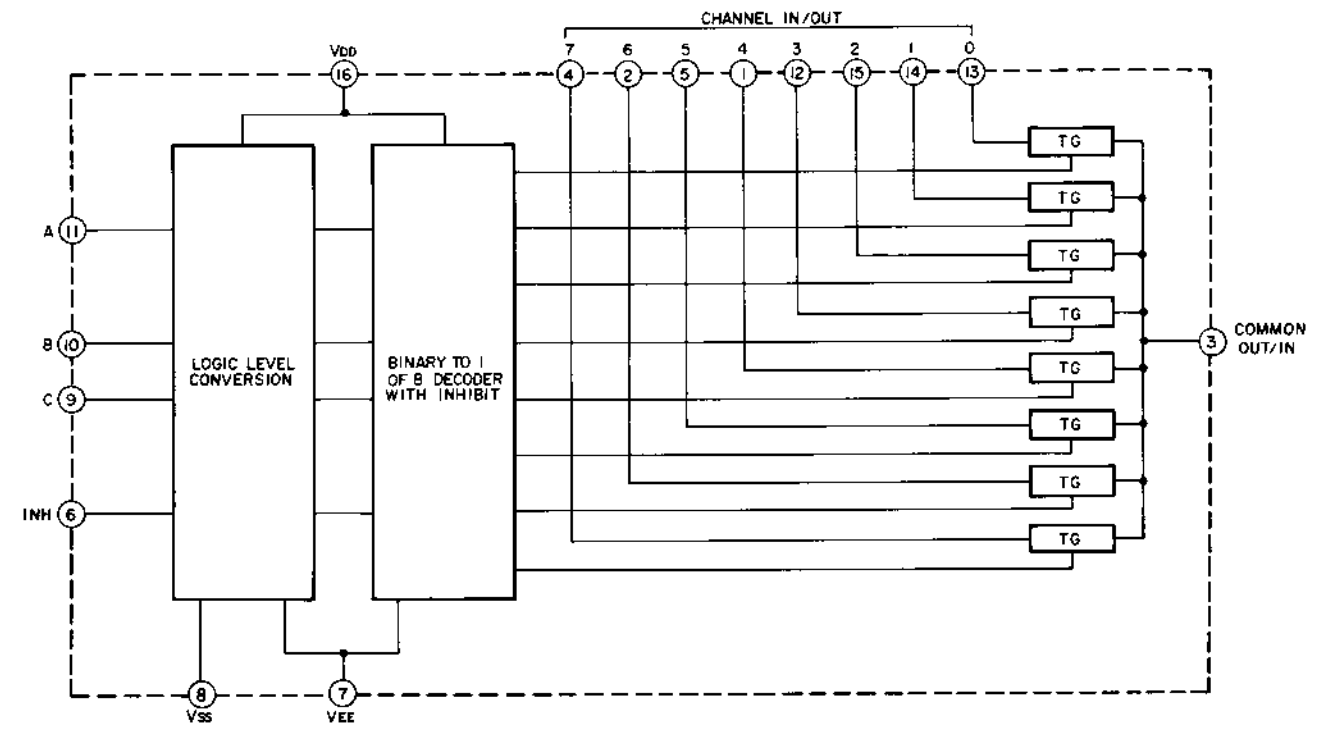

LC7800

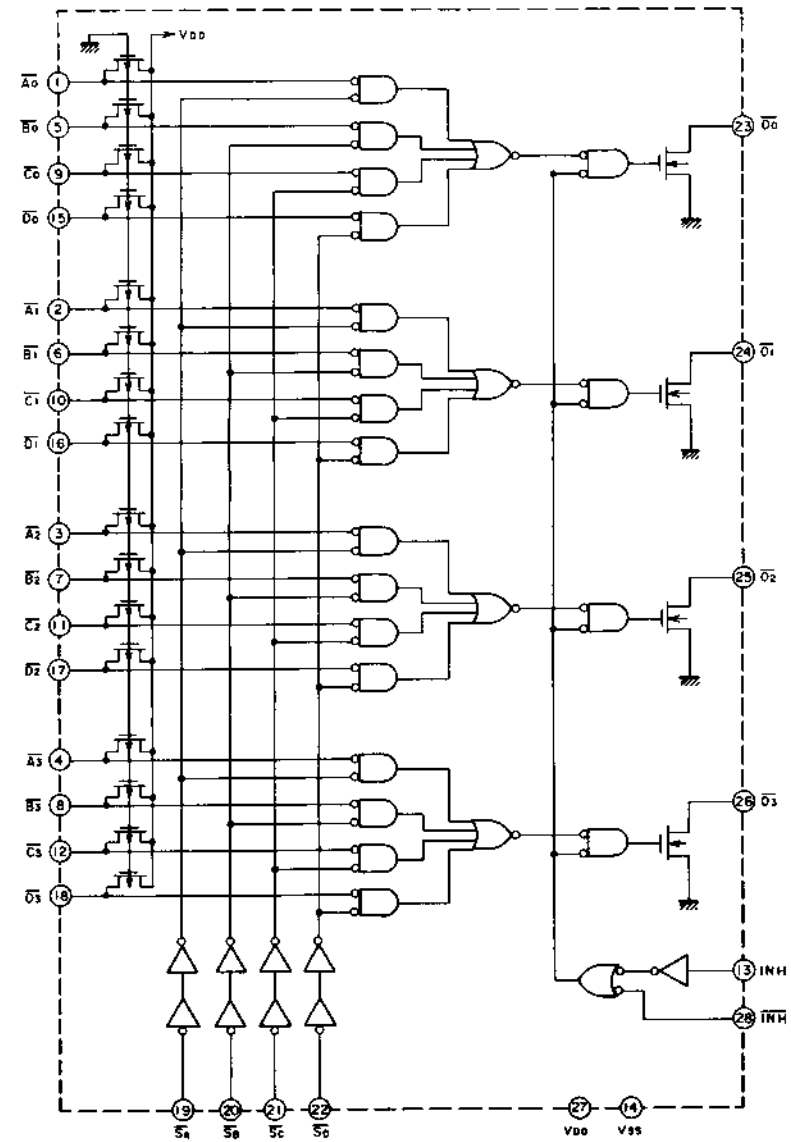

μ PC1043C

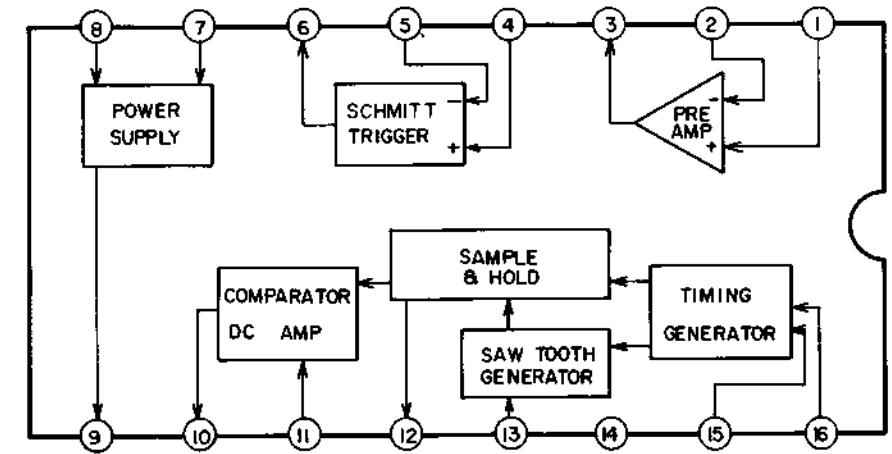

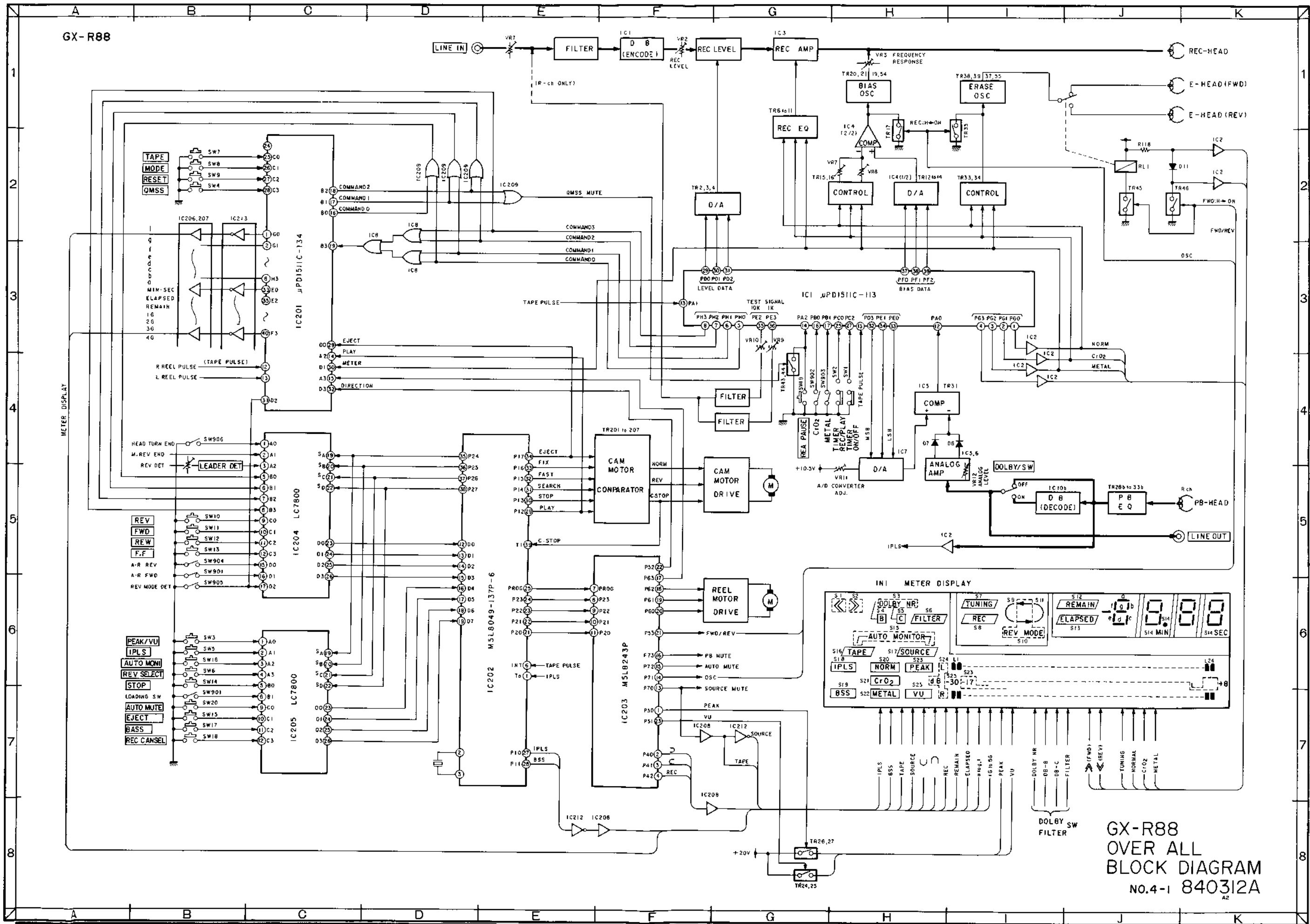

GX-R88
OVER ALL
BLOCK DIAGRAM
NO.4-1 840312A

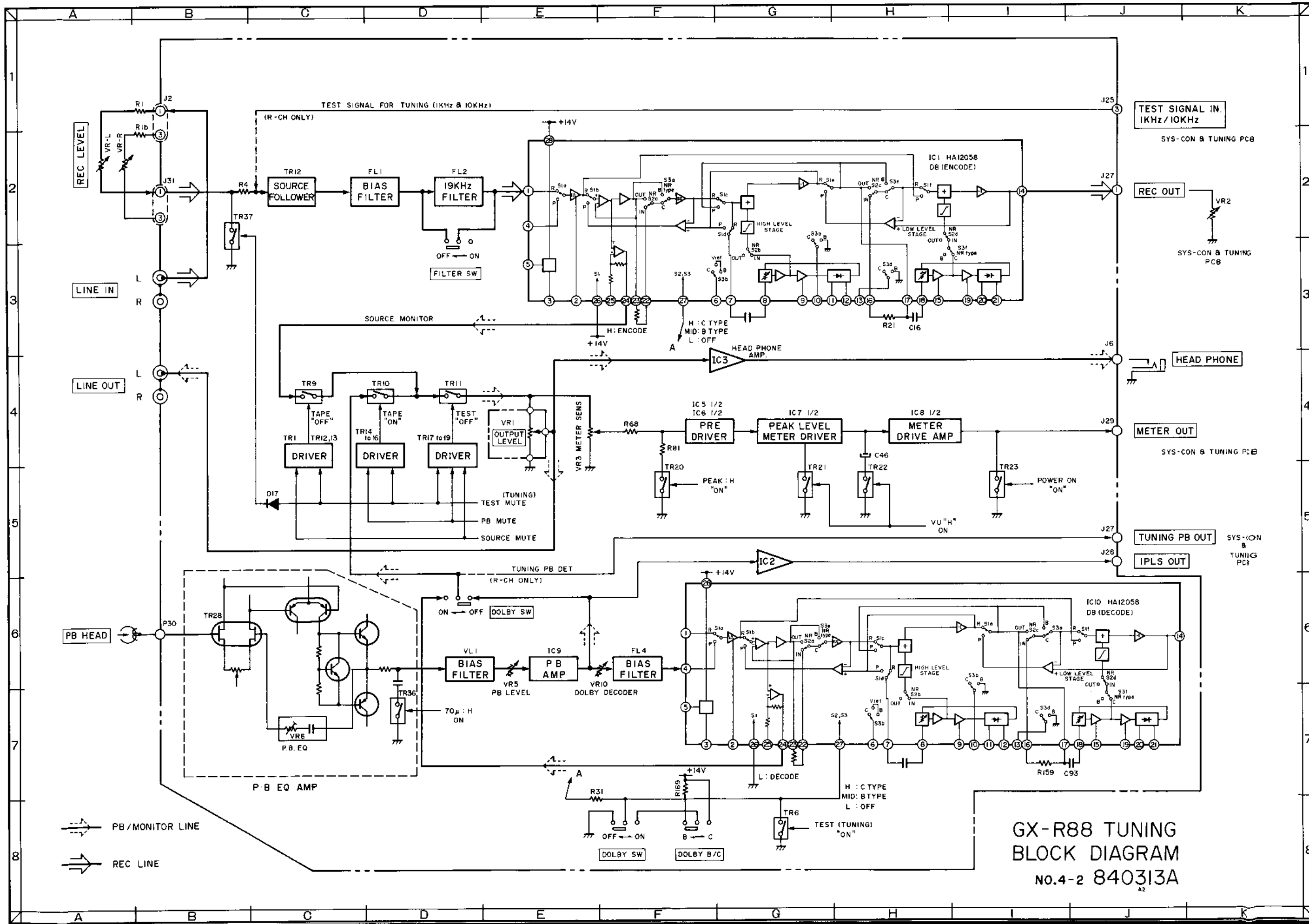

GX-R88 TUNING
BLOCK DIAGRAM
NO.4-2 840313A

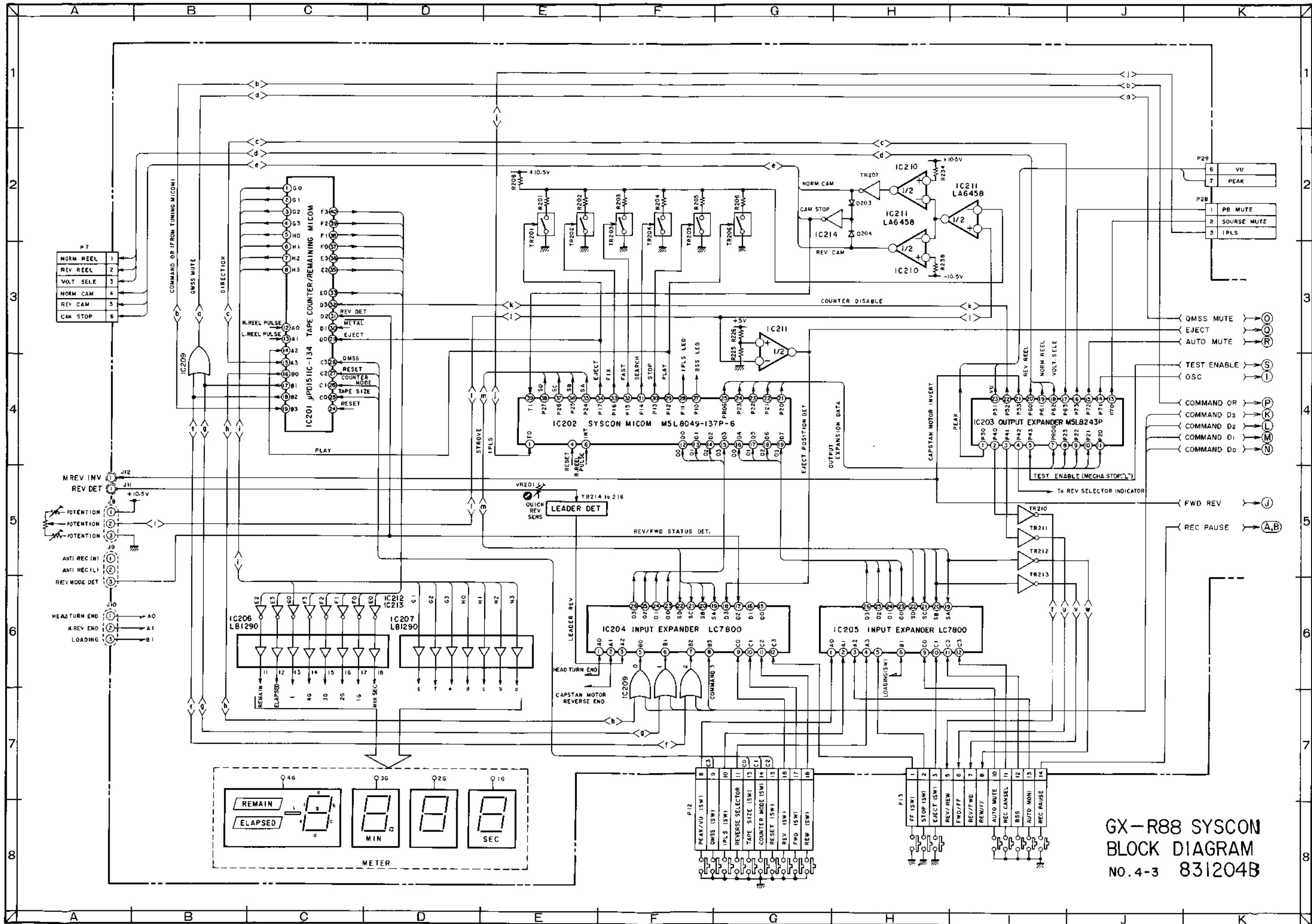

GX-R88 SYSCOM
 BLOCK DIAGRAM
 NO. 4-3 831204B

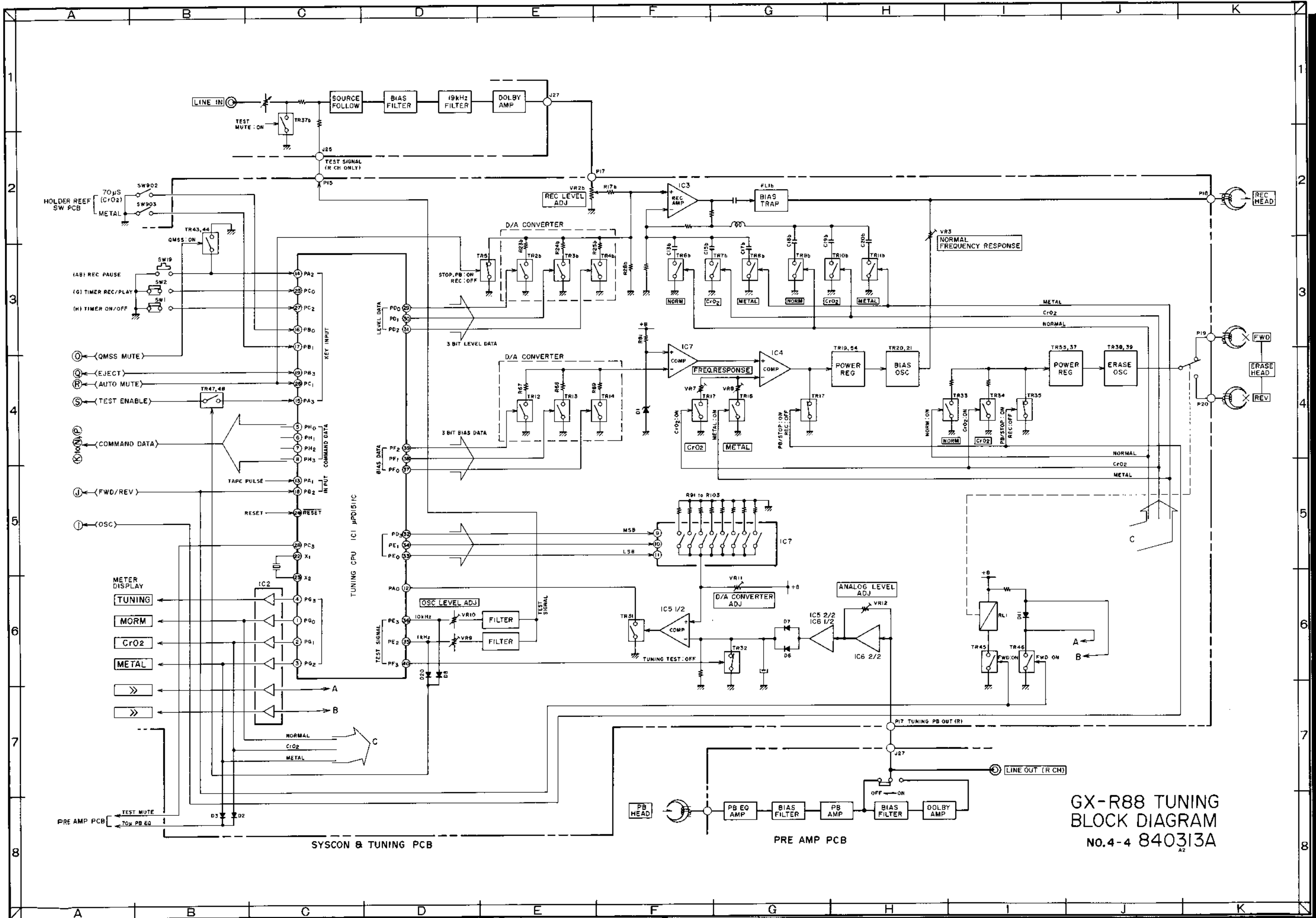

GX-R88 TUNING
BLOCK DIAGRAM
No. 4-4 840313A

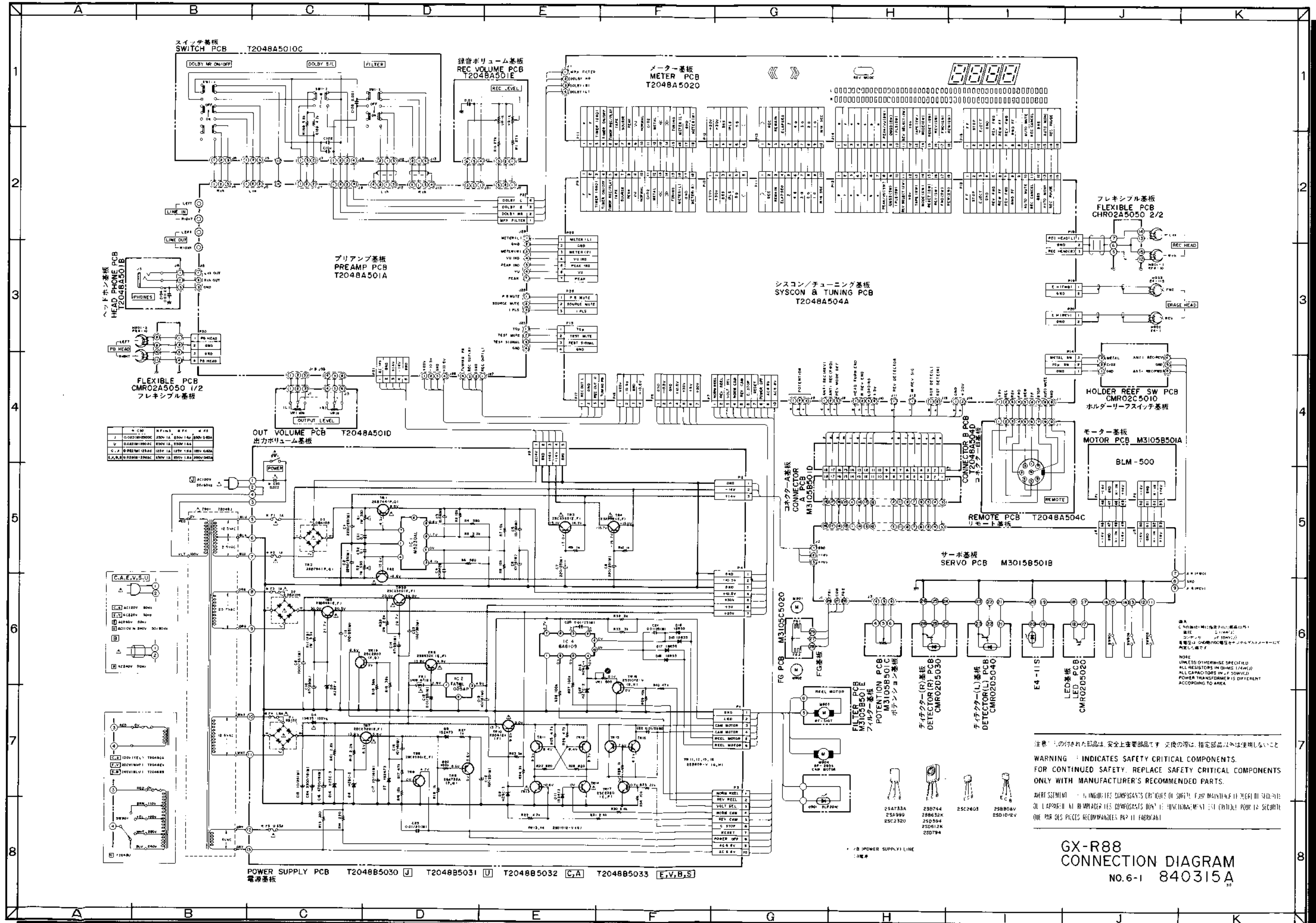

1	0.0022M 200C	250V 1A	250V 1A	250V 0.5A
2	0.0022M 100C	250V 1A	250V 1A	250V 0.5A
3	0.0022M 100C	250V 1A	250V 1A	250V 0.5A
4	0.0022M 100C	250V 1A	250V 1A	250V 0.5A
5	0.0022M 100C	250V 1A	250V 1A	250V 0.5A
6	0.0022M 100C	250V 1A	250V 1A	250V 0.5A
7	0.0022M 100C	250V 1A	250V 1A	250V 0.5A
8	0.0022M 100C	250V 1A	250V 1A	250V 0.5A

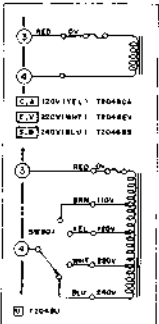
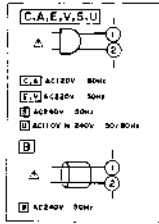

注意：この付された部品は、安全上重要な部品です。交換の際は、指定部品以外は使用しないこと。
 WARNING: INDICATES SAFETY CRITICAL COMPONENTS. FOR CONTINUED SAFETY, REPLACE SAFETY CRITICAL COMPONENTS ONLY WITH MANUFACTURER'S RECOMMENDED PARTS.
 ATTENTION: LES COMPOSANTS CRITIQUES DE SÉCURITÉ. POUR MAINTENIR LE NIVEAU DE SÉCURITÉ DE L'APPAREIL, REMPLACEZ LES COMPOSANTS CRITIQUES SEULEMENT PAR DES PIÈCES RECOMMANDÉES PAR LE FABRICANT.

NOTE: UNLESS OTHERWISE SPECIFIED, ALL RESISTORS IN OHMS (1/4W, 1/2W). ALL CAPACITORS IN μF (50VDC). POWER TRANSFORMER IS DIFFERENT ACCORDING TO AREA.

- 25A723A 25C2320
- 25B744 25B52K 25D594 25D612K 25D794
- 25C2605
- 25B808V 25D102V

GX-R88 CONNECTION DIAGRAM No.6-1 840315A

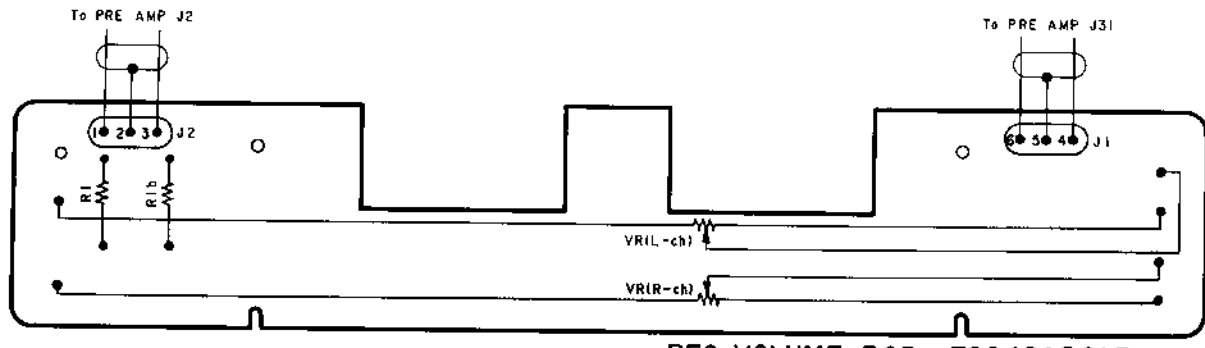

REC VOLUME PCB T2048A501E
録音ボリューム基板

出力ボリューム基板
OUT VOLUME PCB T2048A501E

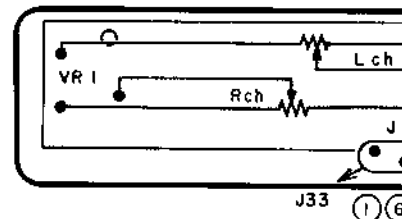

※	F1163	F4	F5
U	250V 1A	250V 1.6A	
J	250V 1A	250V 1.6A	250V 0.63A
C, A	125V 1A	125V 1.6A	125V 0.63A
E, V, B, S	250 1A	250V 1.6A	250V 0.63A

※	C30
U	0.022 (M) 250AC
J	0.022 (M) 250DC
C, A	0.022 (M) 125AC
E, V, B, S	0.022 (M) 250AC

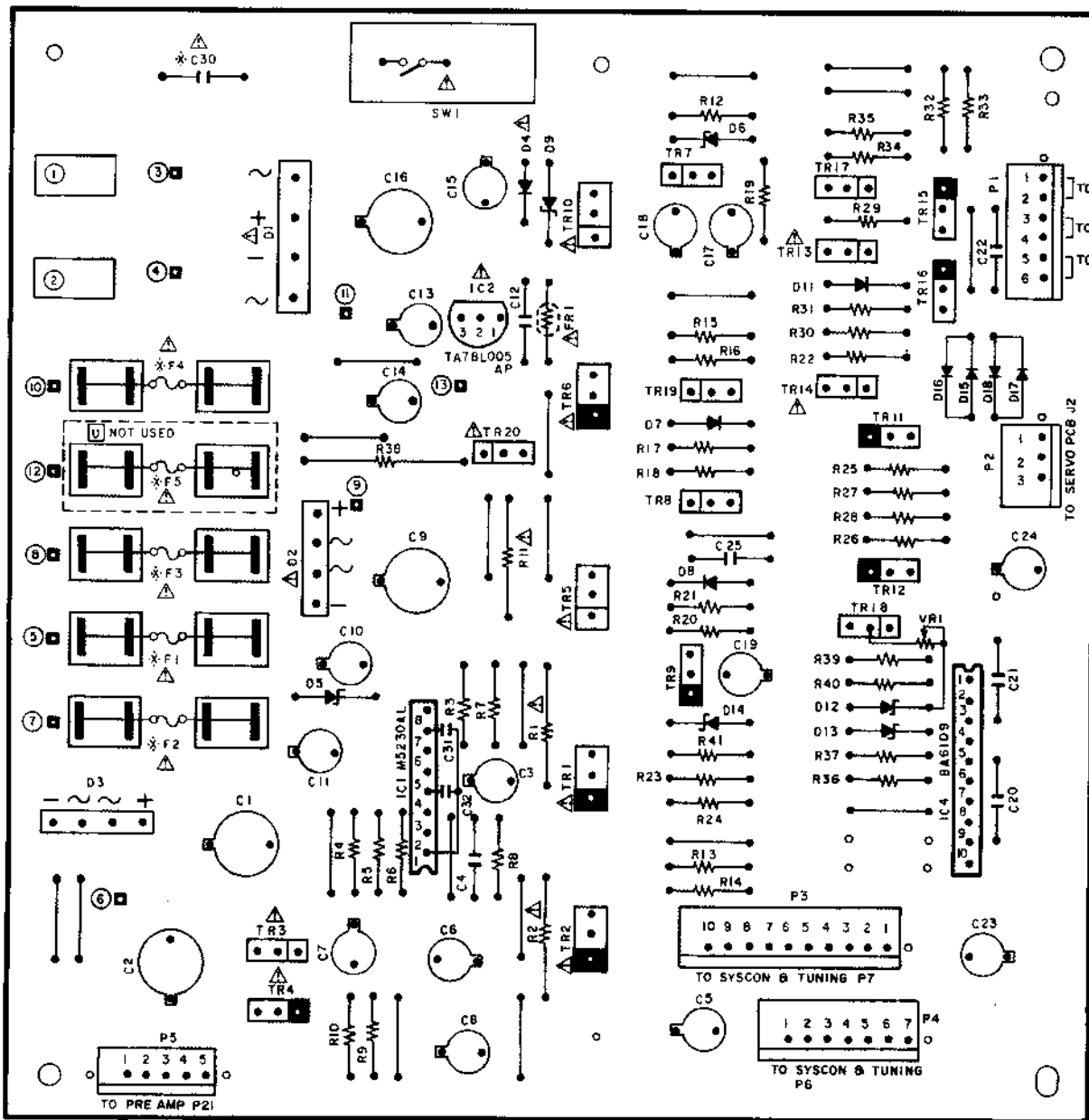

電源基板
POWER SUPPLY PCB

- T2048B5030 J
T2048B5031 U
T2048B5032 C A
T2048B5033 E V S B

- TR1-----2SB744 (P,Q)
TR2-----2SD794 (P,Q)
TR3-----2SC2320 (E,F)
TR4-----2SA999 (E,F)
TR5-----2SD549 (E,F)
TR6-----2SB632K (E,F)
TR7,8,17,19,20--2SC2803 (E,F)
TR9-----2SA733A (P,Q)
TR10-----2SD612K (F)
TR11,12,15,16--2SB808V (G,H)
TR13,14,18----2SD1012V (G)
- = PNP TRANSISTOR
○ = NPN TRANSISTOR
- |> = SILICON DIODE
—|> = GERMANIUM DIODE

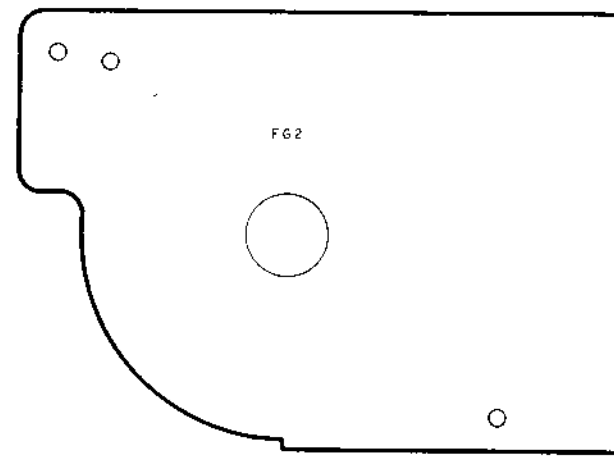
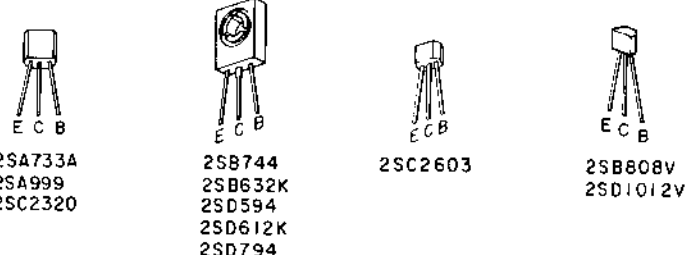

FG PCB M3
FG基板

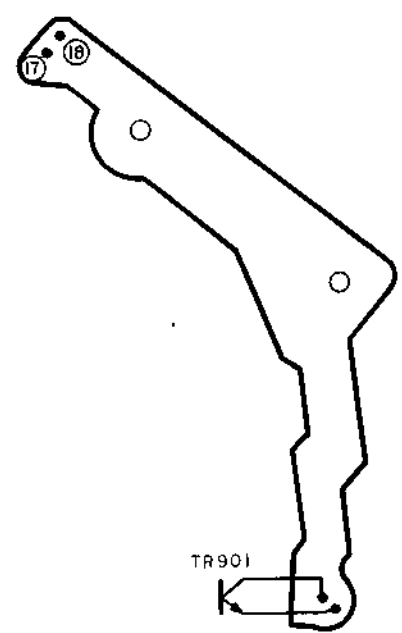

LED基板
LED PCB
CMR02D502

注意: △の付された部品は、安全上重要部品です。交換の際は、指定部品以外は使用しないこと。
WARNING: △ INDICATES SAFETY CRITICAL COMPONENTS. FOR CONTINUED SAFETY, REPLACE SAFETY CRITICAL COMPONENTS ONLY WITH MANUFACTURER'S RECOMMENDED PARTS.
AVERTISSEMENT: △ IL INDIQUE LES COMPOSANTS CRITIQUES DE SURETE. POUR MAINTENIR LE DEGRÉ DE SECURITE DE L'APPAREIL, NE REMPLACER LES COMPOSANTS DONT LE FONCTIONNEMENT EST CRITIQUE POUR LA SECURITE QUE PAR DES PIECES RECOMMANDÉES PAR LE FABRICANT.

カボリューム基板
T VOLUME PCB T2048A501D

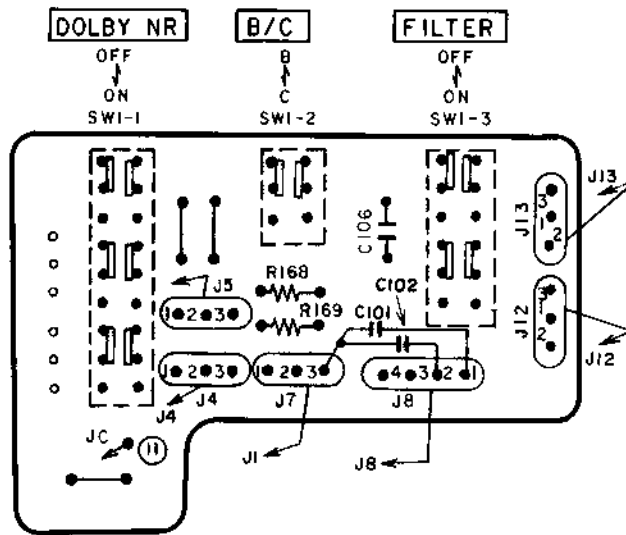
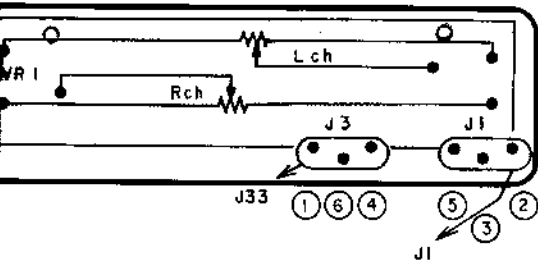

SWITCH PCB T2048A501C
スイッチ基板

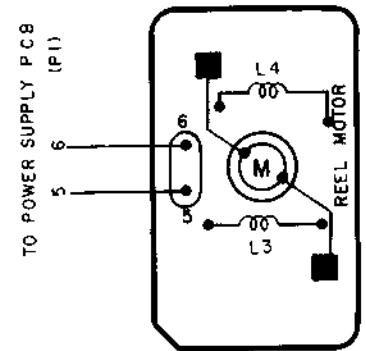

FILTER PCB
M3105B501E
フィルター基板

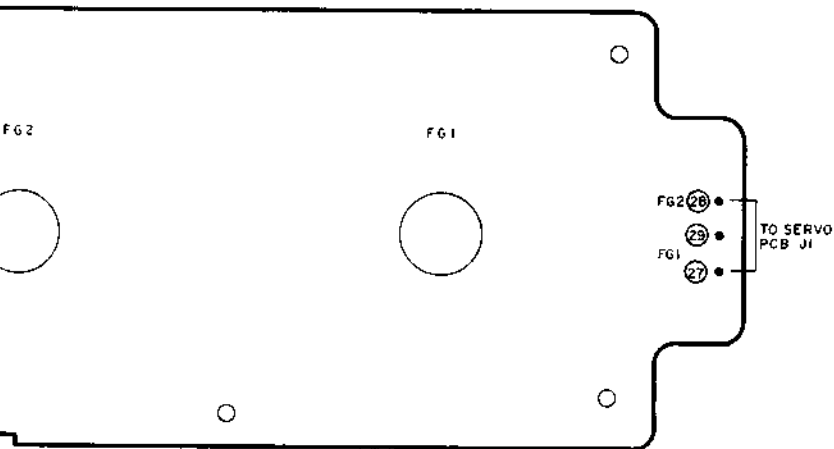

FG PCB M3105C5020
FG基板

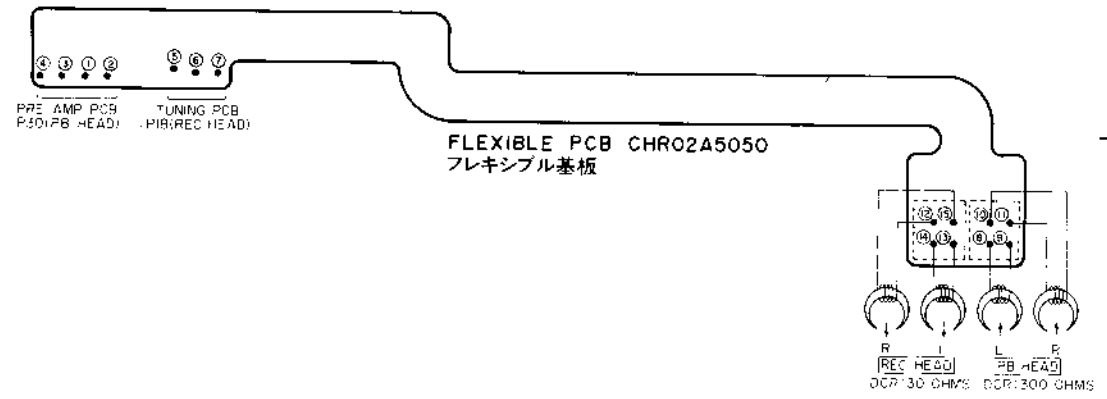

FLEXIBLE PCB CHR02A5050
フレキシブル基板

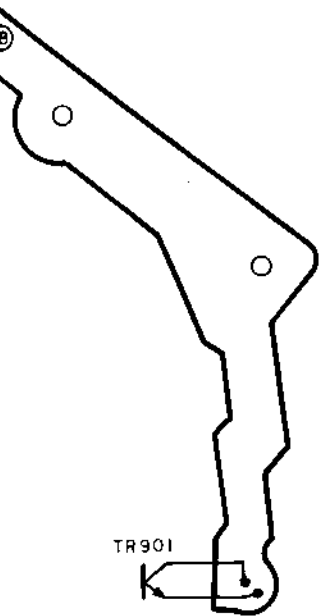

LED基板
LED PCB
CMR02D5020

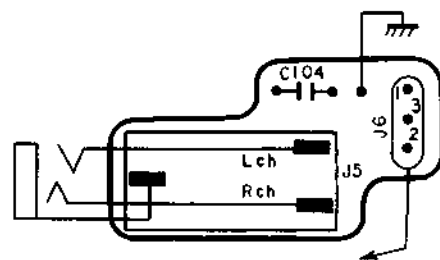

HEAD PHONE PCB T2048A501B
ヘッドホン基板

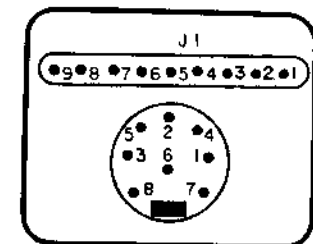

REMOTE CONTROL PCB
T2048B504C
リモートコントロール基板

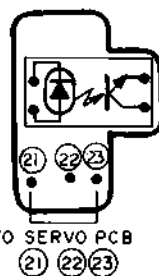

ディテクター(L)基板
DETECTOR(L) PCB
CMR02D5040

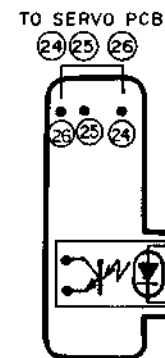

ディテクター(R)基板
DETECTOR(R) PCB
CMR02D5030

シスコン/チューニング基板
 SYSCON & TUNING PCB T2048A5040

コネクターB基板
 CONNECTOR B PCB T2048A504D

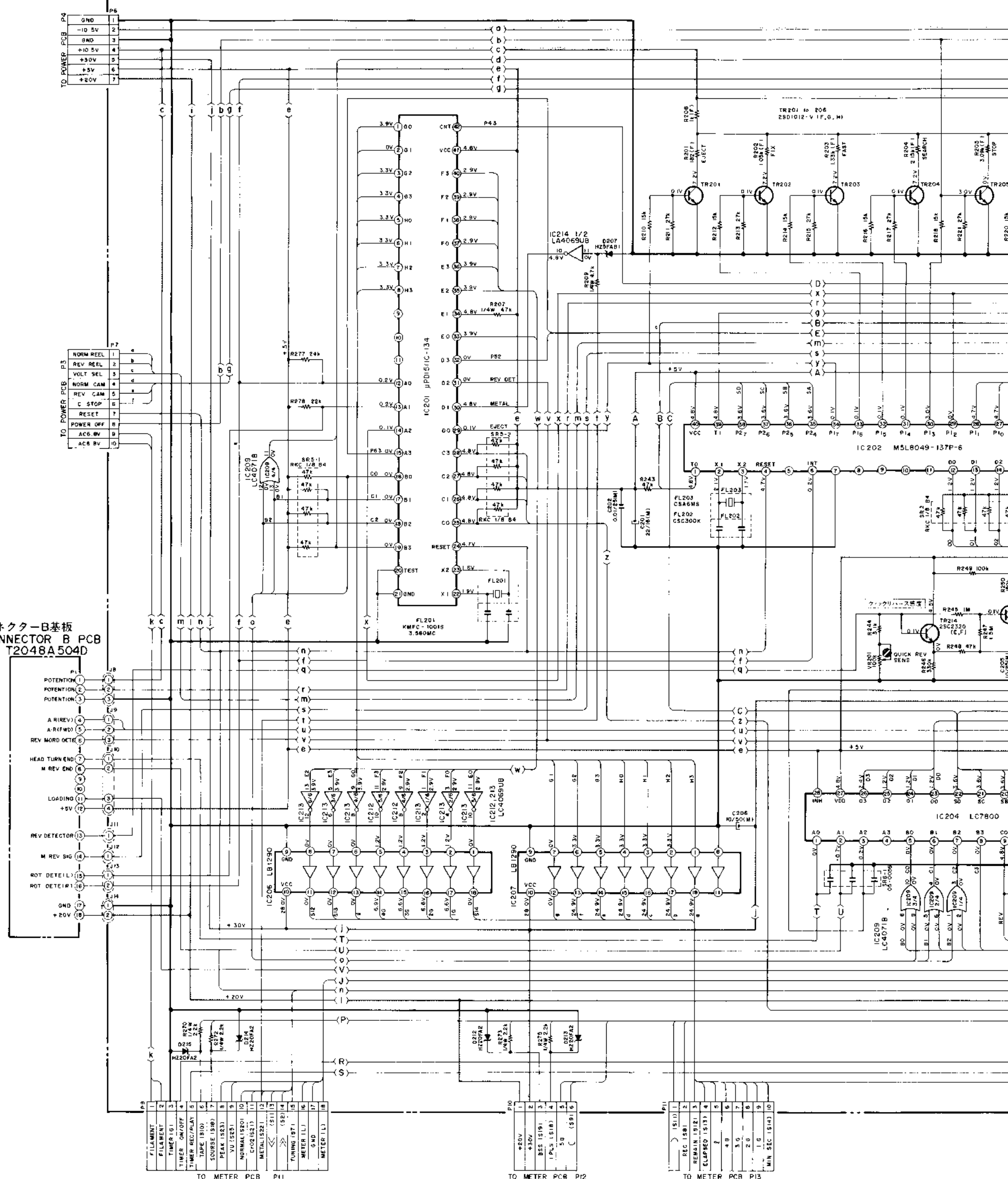

-B (POWER SUPPLY) LINE
 =B電源線

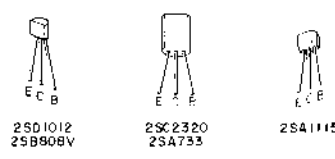

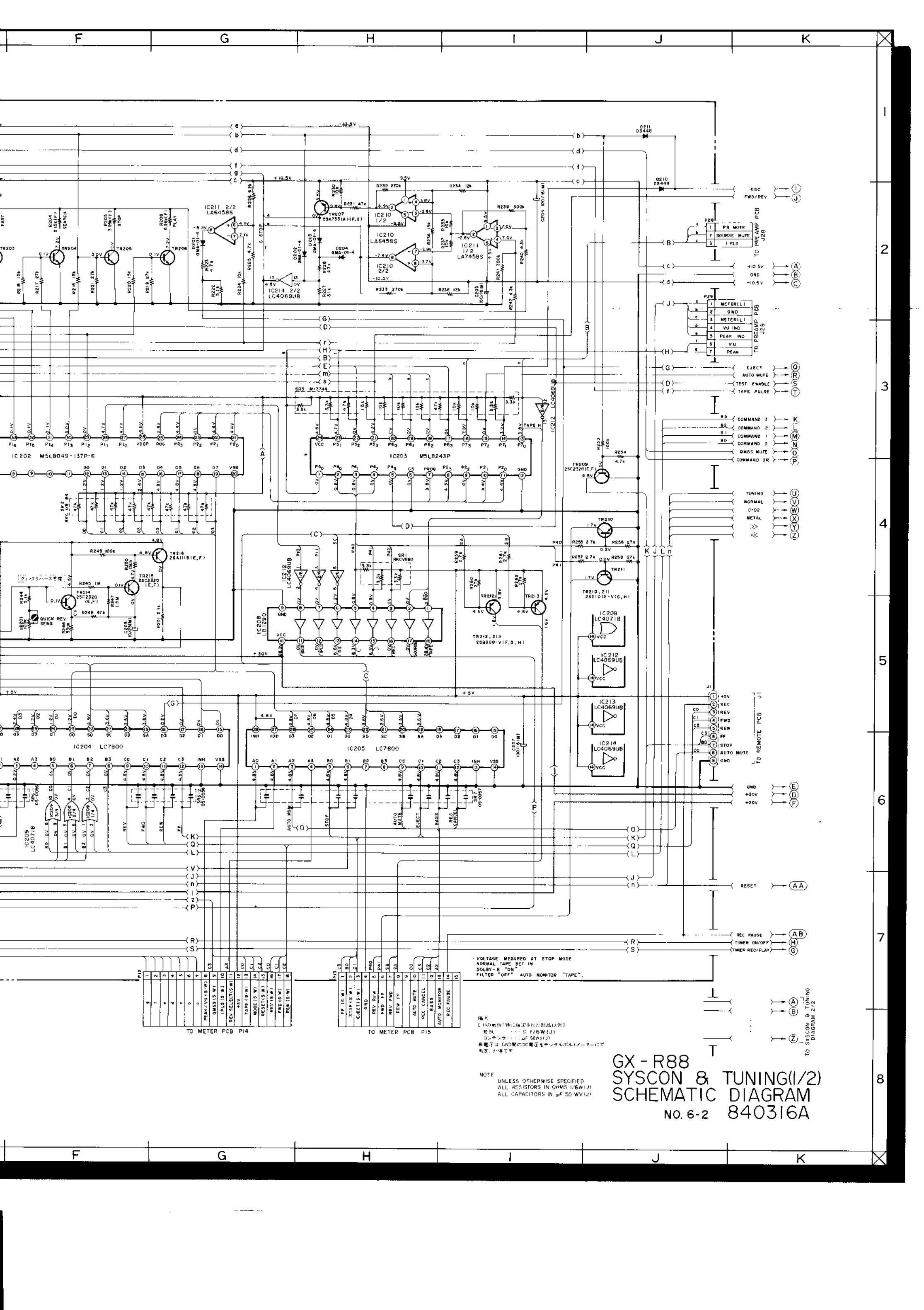

TO METER PCB P14

P12	1	PEAK/VOLTS W/ B
	2	QMS (S) W/ B
	3	IPLS (S) W/ B
	4	REC SELECT (S) W/ B
	5	+5V
	6	TAPE (S) W/ B
	7	MODE (S) W/ B
	8	RESET (S) W/ B
	9	REV (S) W/ B
	10	END (S) W/ B
	11	REV (S) W/ B
	12	REV (S) W/ B

TO METER PCB P15

P13	1	FF (S) W/ B
	2	STOP (S) W/ B
	3	EJECT (S) W/ B
	4	PAUSE
	5	REV (S) W/ B
	6	FWD (S) W/ B
	7	REV (S) W/ B
	8	REV (S) W/ B
	9	CO
	10	AUTO MUTE
	11	REC CANCEL
	12	BASS
	13	AUTO MONITOR
	14	REC PAUSE
	15	

VOLTAGE MEASURED AT STOP MODE
 NORMAL TAPE SET IN
 DOLBY-B "ON"
 FILTER "OFF" AUTO MONITOR "TAPE".

備註
 C (10) 単位に指定された部品以外は
 抵抗 ... Ω 1/6W (J)
 コンデンサ ... μF 50V (J)
 各種印は、GND側の電圧をテスタルポルトメータにて
 測定した値です

NOTE
 UNLESS OTHERWISE SPECIFIED
 ALL RESISTORS IN OHMS 1/6W (J)
 ALL CAPACITORS IN μF 50V (J)

GX-R88
 SYSCON & TUNING(1/2)
 SCHEMATIC DIAGRAM
 No. 6-2 840316A

TO SYSCON & TUNING
 DIAGRAM 2/2

J8, 9, 10, 11 }
12, 13, 14 } → TO CONNECTOR B PCB. J1

LOCATION OF COMPONENTS

IC'S

- | | |
|------------|--------------|
| IC1-----4E | IC201-----4B |
| IC2-----2D | IC202-----2B |
| IC3-----2G | IC203-----5B |
| IC4-----6E | IC204-----2B |
| IC5-----2E | IC205-----1B |
| IC6-----1E | IC206-----4A |
| IC7-----3F | IC207-----3A |
| IC8-----1D | IC208-----5A |
| IC9-----1E | IC209-----3C |
| | IC210-----2C |
| | IC211-----2C |
| | IC212-----5B |
| | IC213-----5B |
| | IC214-----4C |

TR'S

- | | |
|--------------------|---------------------|
| TR1-----1E | TR37-----5F |
| TR2, 3-----1G | TR38, 39-----6F |
| TR2b-----1F | TR43-----1D |
| TR3b, 4b-----1G | TR44-----1E |
| TR5, 5b-----1F | TR45-----5F |
| TR6 to 8-----3G | TR46-----2D |
| TR6b to 8b-----3G | TR47-----4F |
| TR9 to 11-----4G | TR48-----5F |
| TR9b to 11b-----4G | TR49-----1F |
| TR12 to 15-----6E | TR54-----6F |
| TR16-----5F | TR55-----5F |
| TR17-----6F | TR201 to 203-----2C |
| | TR204 to 206-----1C |
| | TR207-----2C |
| | TR209-----3C |
| | TR210 to 213-----1C |
| | TR214 to 216-----5C |

- | | |
|--------------------------|-----------------|
| TR 1, 44, 216----- | 2SA1115(E,F) |
| TR2 to 4, 6 to 11 | 2SC3383(S,T) |
| 2b to 4b, 6b to 11b | 2SC3320(E,F) |
| TR12 to 17, 29 to 35, 43 | 2SC1815(BL,GR) |
| 46, 209, 214, 215 | 2SC2274K(E) |
| TR19, 37 | 2SD1012-V(G,H) |
| TR20, 21, 38, 39 | 2SC3399 |
| TR5, 5b, 45, 201 to 206 | 2SB764(EF) |
| 210, 211 | 2SB632K(EF) |
| TR47 to 49 | 2SA733A(P,Q) |
| TR54 | 2SB808-V(F,G,H) |
| TR55 | |
| TR207 | |
| TR212, 213 | |

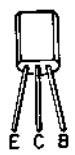

2SC3383
2SC2320
2SC1815
2SC2274
2SB764
2SA733

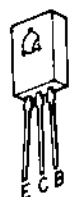

2SB632



2SA1115
2SC3399



2SD1012
2SB808

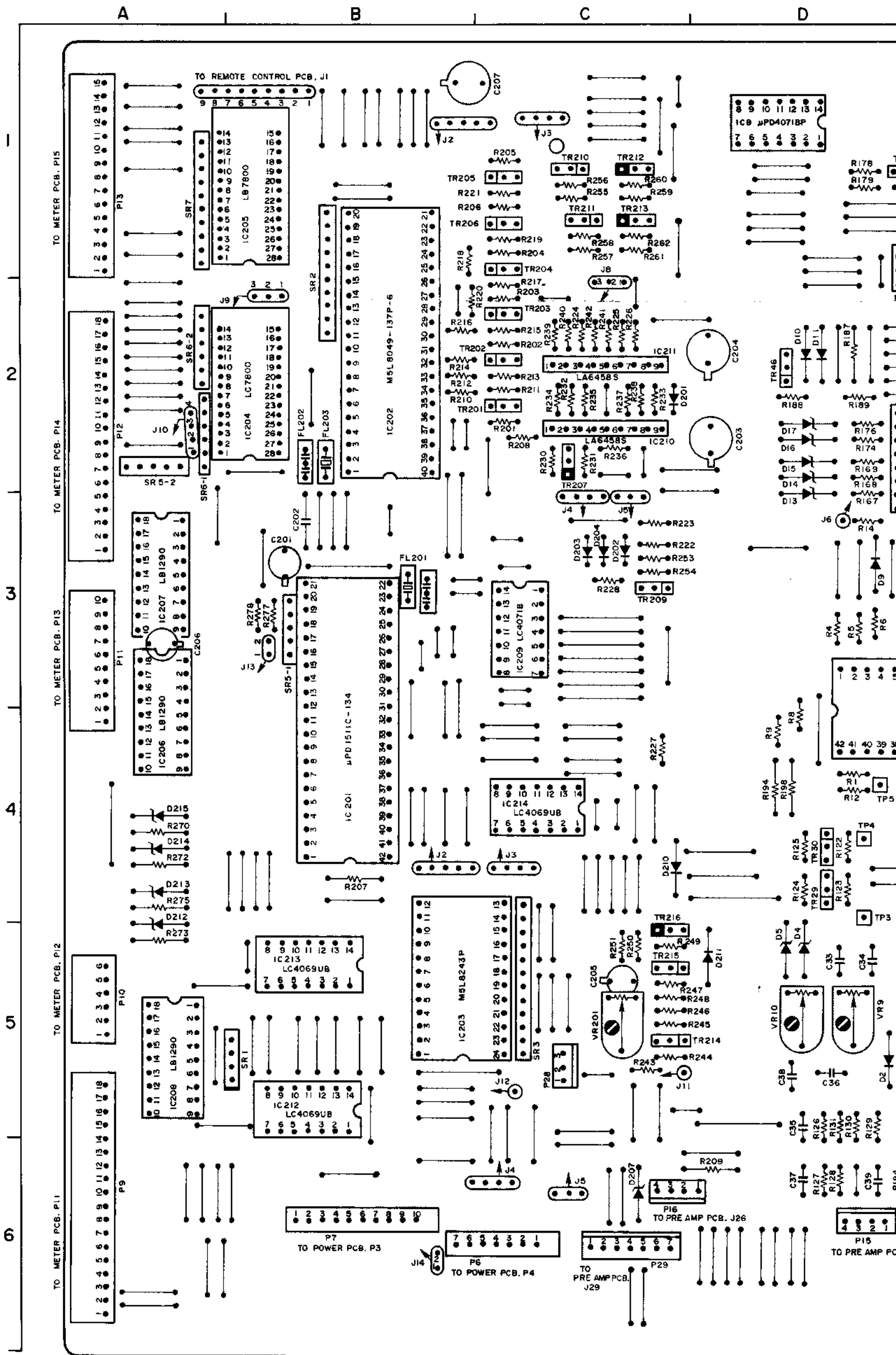

△の付された部品は、安全上重要部品です。交換の際は、指定部品以外は使用しないこと。
 WARNING: △ INDICATES SAFETY CRITICAL COMPONENTS.
 FOR CONTINUED SAFETY, REPLACE SAFETY CRITICAL COMPONENTS ONLY WITH MANUFACTURER'S RECOMMENDED PARTS.
 △の付された部品は、安全上重要部品です。交換の際は、指定部品以外は使用しないこと。
 APPAREIL NE REMPLACER LES COMPOSANTS CRITIQUES DE SURETE POUR MAINTENIR LE DEGRÉ DE SURETE
 SEULMENT PAR DES PIÈCES RECOMMANDÉES PAR LE FABRICANT.

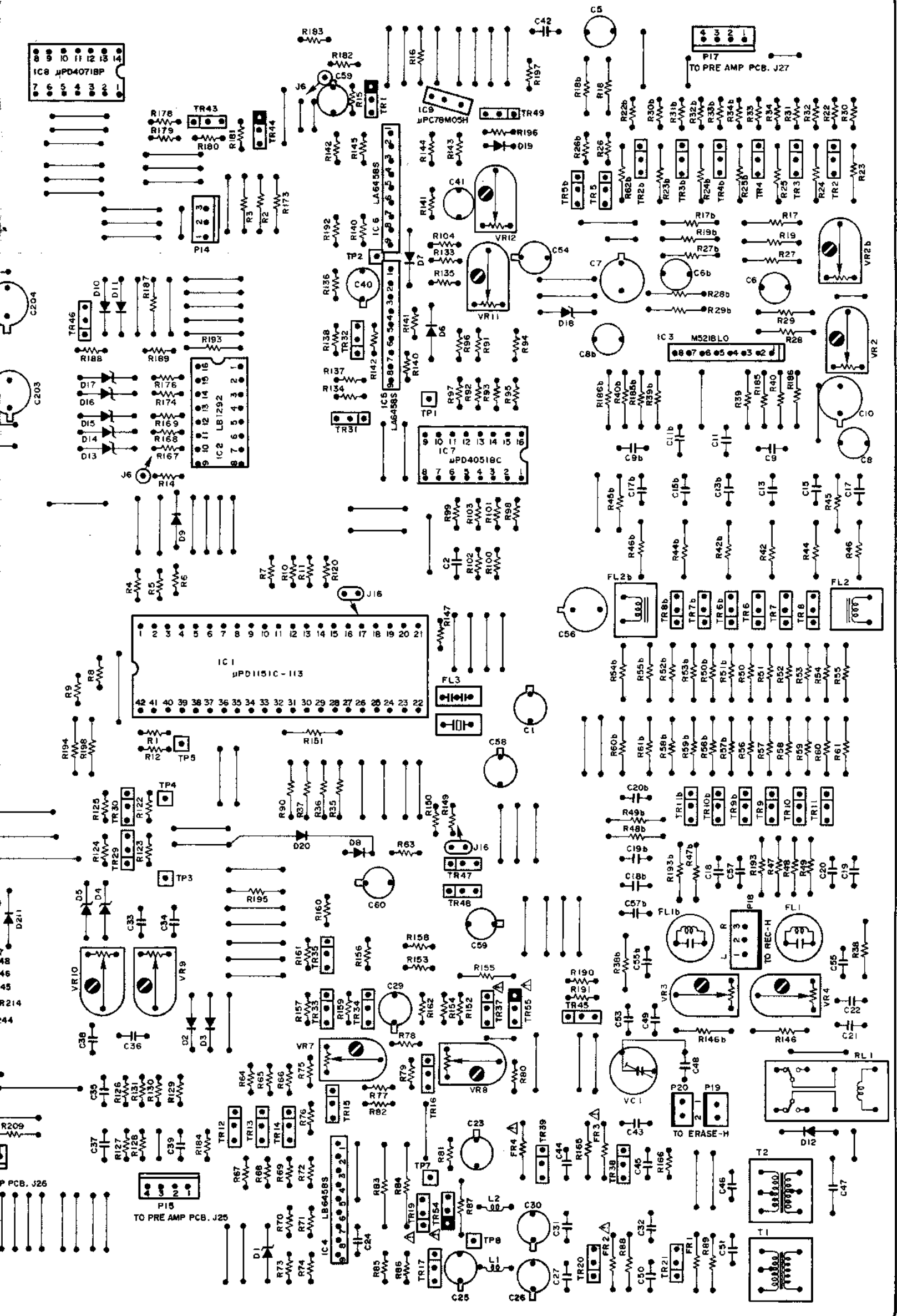

- VR2-----REC LEVEL Lch
- VR2b-----REC LEVEL Rch
- VR3-----FREQ RESPONSE(NORMAL) Lch
- VR4-----FREQ RESPONSE(NORMAL) Rch
- VR7-----FREQ RESPONSE(CR02)
- VR8-----FREQ RESPONSE(METAL)
- VR9-----TEST SIGNAL (1KHz LEVEL)
- VR10-----TEST SIGNAL (10KHz LEVEL)
- VR11-----A/D CONVERTOR
- VR12-----ANALOG LEVEL
- VR20-----QUICK REV SENS
- T1-----BIAS FREQ
- T2-----ERASE FREQ (REV)
- VC1-----ERASE FREQ (FWD)

- = PNP TRANSISTOR
- = NPN TRANSISTOR
- = GERMANIUM DIODE
- = SILICON DIODE

SYSTEM CONTROL & TUNING PCB T2048A504A(2ED)
システムコントロール/チューニング基板

J8, 9, 10, 11 } TO CONNECTOR B PCB, J1
 12, 13, 14 }

LOCATION OF COMPONENTS

IC'S

IC1-----4E	IC201-----4B
IC2-----2D	IC202-----2B
IC3-----2G	IC203-----5B
IC4-----6E	IC204-----2B
IC5-----2E	IC205-----1B
IC6-----1E	IC206-----4A
IC7-----3F	IC207-----3A
IC8-----1D	IC208-----5A
IC9-----1E	IC209-----3C
	IC210-----2C
	IC211-----2C
	IC212-----5B
	IC213-----5B
	IC214-----4C

TR'S

TR1-----1E	TR37-----5F
TR2, 3-----1G	TR38, 39-----6F
TR2b-----1F	TR43-----1D
TR3b, 4b-----1G	TR44-----1E
TR5, 5b-----1F	TR45-----5F
TR6 to 8-----3G	TR46-----2D
TR6b to 8b-----3G	TR47-----4F
TR9 to 11-----4G	TR48-----5F
TR9b to 11b-----4G	TR49-----1F
TR12 to 15-----6E	TR54-----6F
TR16-----5F	TR55-----5F
TR17-----6F	TR201 to 203-----2C
	TR204 to 206-----1C
	TR207-----2C
	TR209-----3C
	TR210 to 213-----1C
	TR214 to 216-----5C

TR 1, 44, 216-----2SA1115 (EF)
TR2 to 4, 6 to 11-----2SC3383 (S, T)
2b to 4b, 6b to 11b-----2SC3383 (S, T)
TR12 to 17, 29 to 35, 43-----2SC2320 (E, F)
46, 209, 214, 215-----2SC2320 (E, F)
TR19, 37-----2SC1815 (BL, GR)
TR20, 21, 38, 39-----2SC2274 (K, E)
TR5, 5b, 45, 201 to 206-----2SD1012-V (G, H)
210, 211-----2SD1012-V (G, H)
TR47 to 49-----2SC3399
TR54-----2SB764 (EF)
TR55-----2SB632 (EF)
TR207-----2SA733A (P, Q)
TR212, 213-----2SB808-V (F, G, H)



2SC3383
 2SC2320
 2SC1815
 2SC2274
 2SB764
 2SA733



2SA1115
 2SC3399
 2SD1012
 2SB808

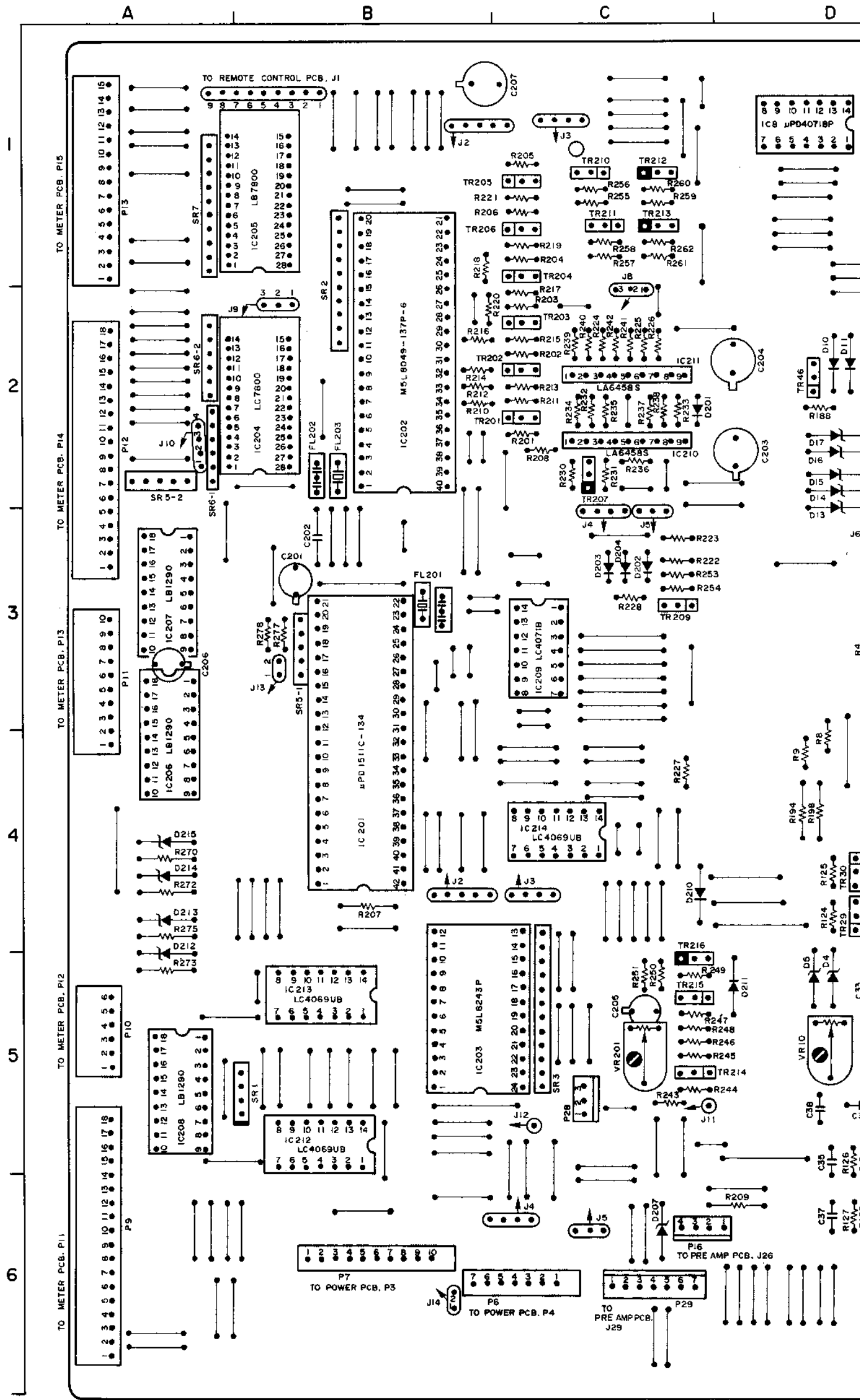

注意: 上の付された部品は、安全上重要部品です。交換の際は、指定部品以外は使用しないこと。
 WARNING: * INDICATES SAFETY CRITICAL COMPONENTS. FOR CONTINUED SAFETY, REPLACE SAFETY CRITICAL COMPONENTS ONLY WITH MANUFACTURER'S RECOMMENDED PARTS.
 Avertissement: * IL INDIQUE LES COMPOSANTS CRITIQUES DE SURETE POUR MAINTENIR LE DEGRE DE SECURITE DE L'APPAREIL. NE REMPLACEZ LES COMPOSANTS QUI LE FONCTIONNEMENT EST CRITIQUE POUR LA SECURITE QUE PAR DES PIECES RECOMMANDEES PAR LE FABRICANT

D

E

F

G

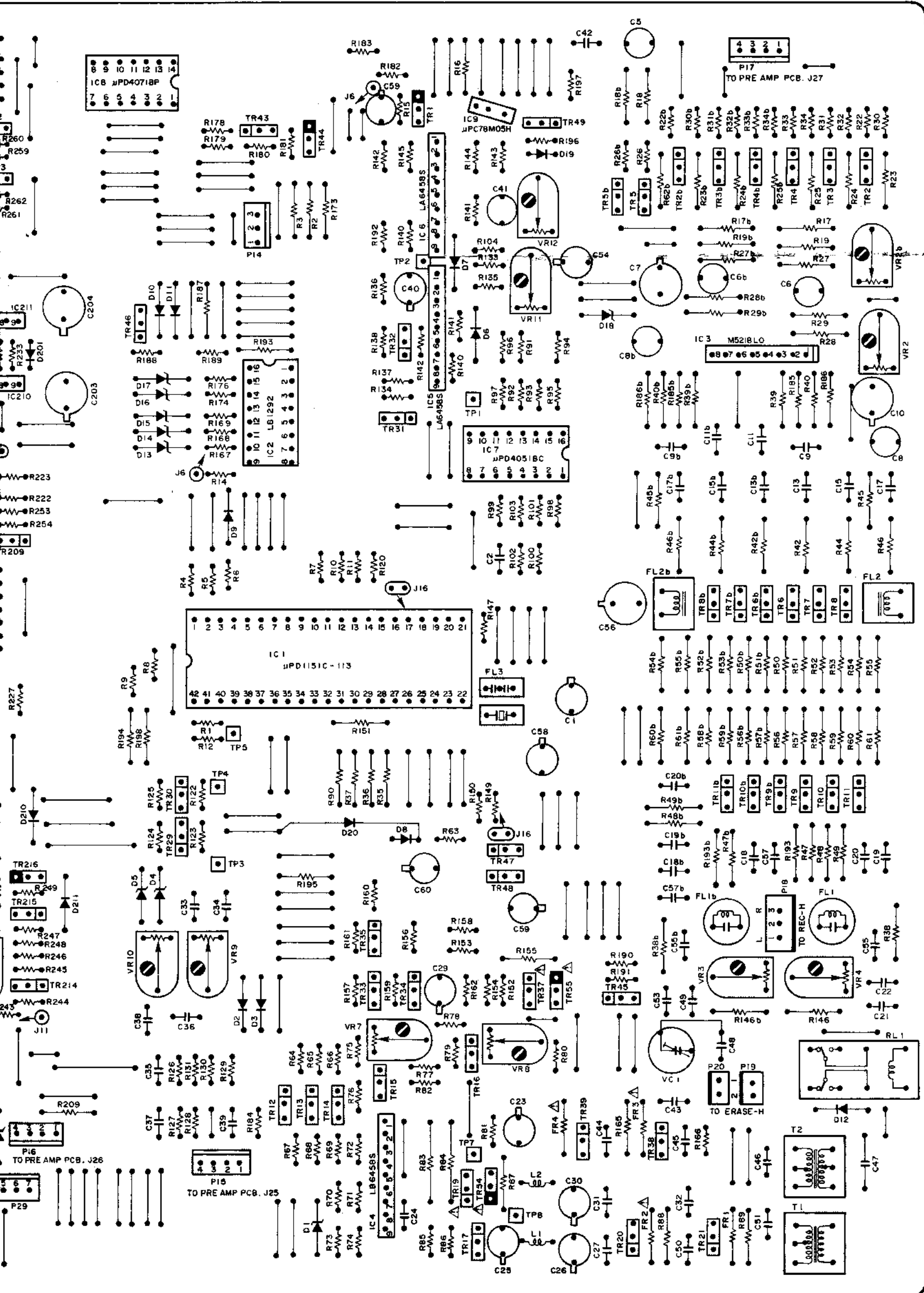

- VR2-----REC LEVEL Lch
- VR2b-----REC LEVEL Rch
- VR3-----FREQ RESPONSE (NORMAL) Lch
- VR4-----FREQ RESPONSE (NORMAL) Rch
- VR7-----FREQ RESPONSE (CF02)
- VR8-----FREQ RESPONSE (METAL)
- VR9-----TEST SIGNAL (1KHz LEVEL)
- VR10-----TEST SIGNAL (10KHz LEVEL)
- VR11-----A/D CONVERTOR
- VR12-----ANALOG LEVEL
- VR201-----QUICK REV SENS
- T1-----BIAS FREQ
- T2-----ERASE FREQ (REV)
- VC1-----ERASE FREQ (FWD)

- = PNP TRANSISTOR
- = NPN TRANSISTOR
- = GERMANIUM DIODE
- = SILICON DIODE

SYSTEM CONTROL & TUNING PCB T2048A504A(2ED)
 システムコントロール/チューニング基板

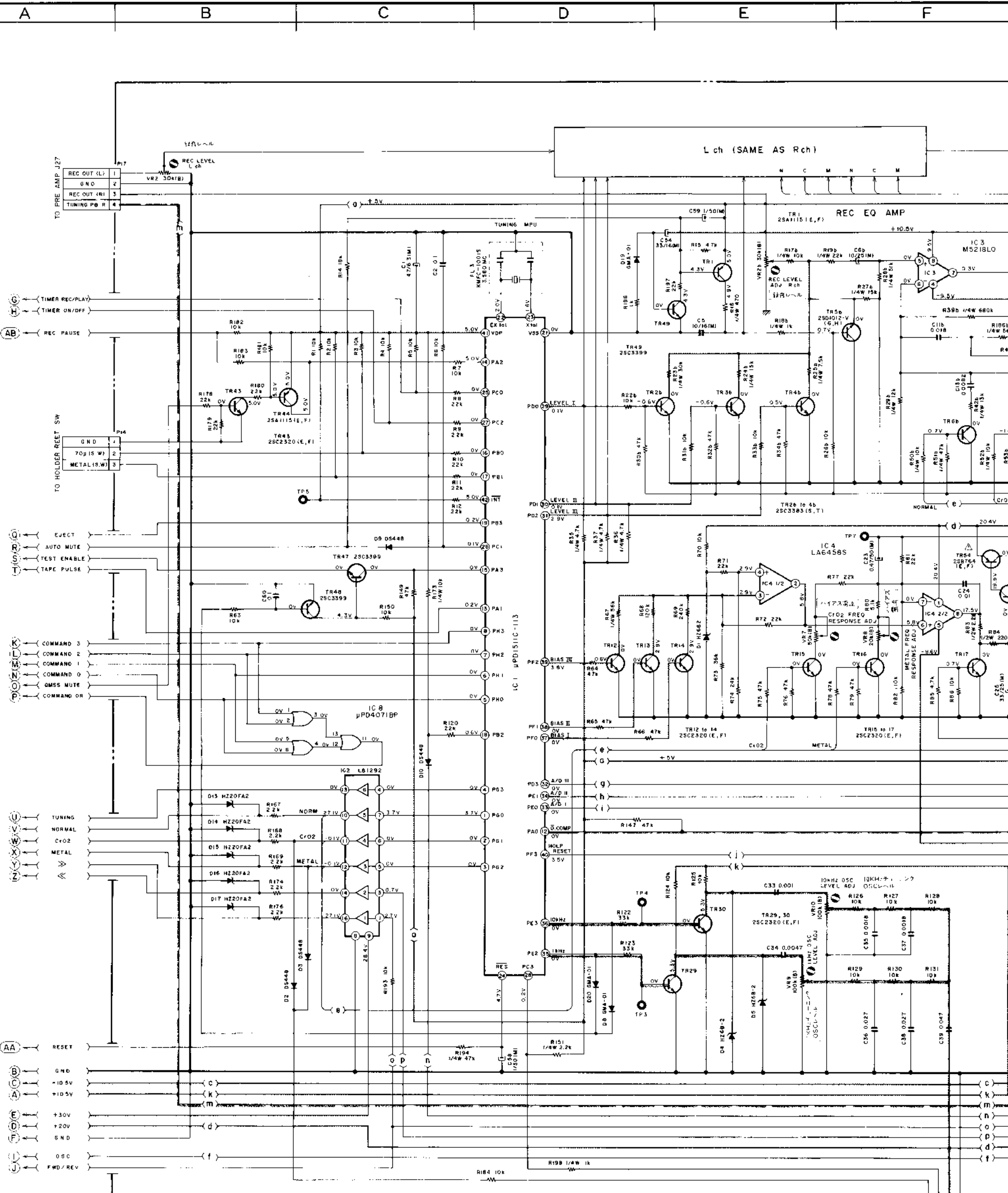

TO SYSCON & TUNING DIAGRAM 1/2

IC 4	BIAS OSC CIRCUIT REC MODE		
	NORMAL	C102	METAL
1	5.4V	5.1V	5.8V
2	2.9V	2.9V	2.9V
3	2.9V	2.9V	2.9V
4	5.4V	5.2V	5.8V
5	5.4V	5.2V	5.8V
6	7.1V	9.8V	18.4V

IC 1	BIAS OSC CIRCUIT REC MODE		
	NORMAL	C102	METAL
TR19 B	6.5V	8.2V	17.8V
TR54 C	7.1V	9.8V	18.4V
TR20 B	-0.5V	-1.0V	-2.7V
TR5 C	8.5V	9.2V	17.8V
TR21 B	-0.7V	-7.3V	-7.8V
TR5 C	6.5V	9.2V	17.8V

IC 3	ERASE HEAD CIRCUIT REC MODE		
	NORMAL	C102	METAL
TR37 B	7.3V	10.1V	18.5V
TR38 B	0.5V	0.5V	-0.4V
TR39 B	1.8V	1.7V	-0.6V
TR55 C	6.8V	9.5V	17.8V

シスコ SYSC

TO PRE AMP J25

トランジスタ: 2SC3383, 2SC2520, 2SC1815, 2SB764, 2SC2274

REC SIGNAL LINE 録音信号
 TUNING TEST SIGNAL LINE チューニングテスト信号
 TUNING PB DET LINE チューニング再生信号
 LEVEL CONTROL レベルコントロール信号
 BIAS CONTROL ハイバイコントロール信号
 B (POWER SUPPLY) LINE 電源

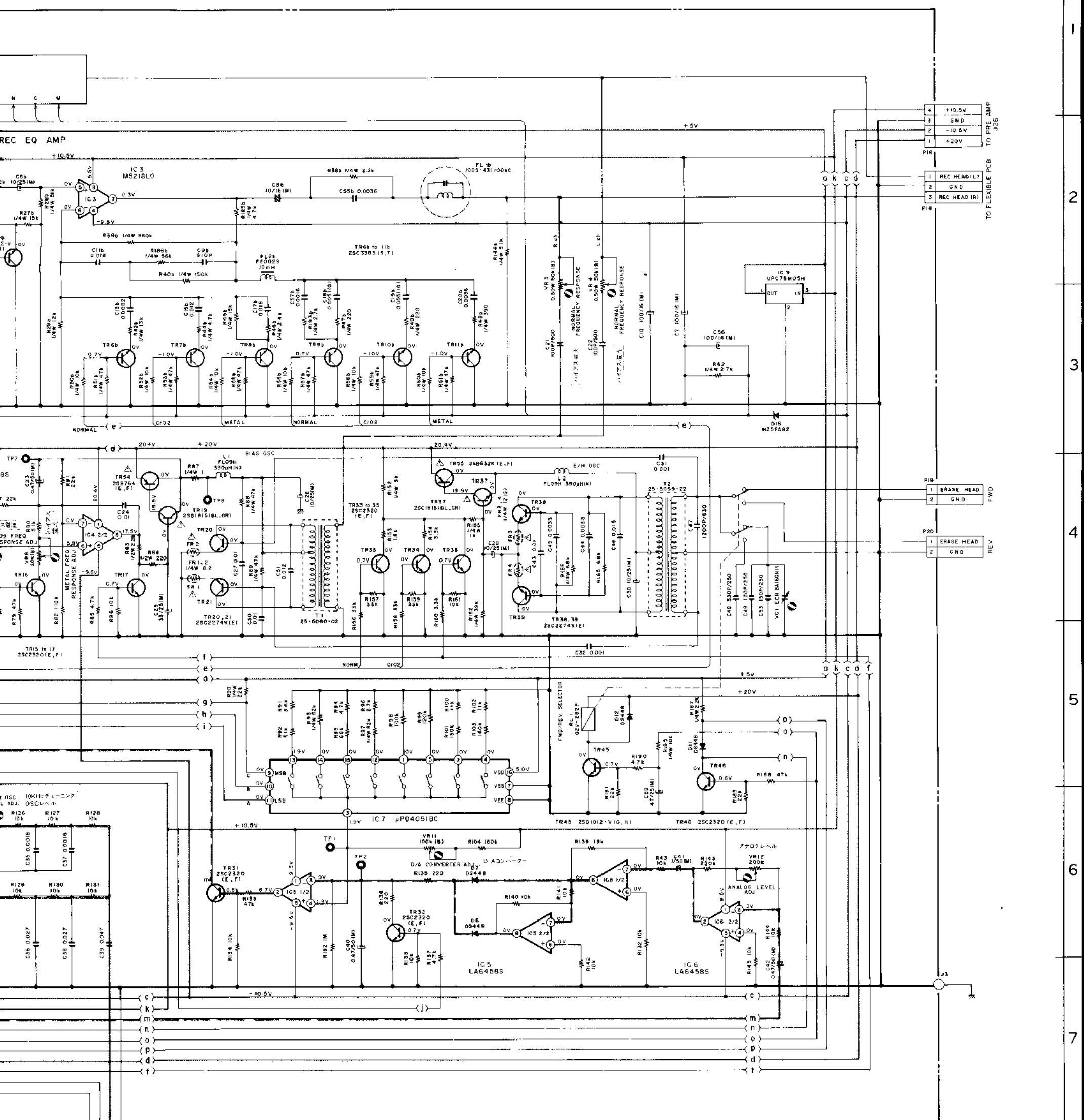

シスコン/チューニング基板
SYSCON & TUNING PCB T2048A5040

注意: 1. の付された部品は、安全上重要部品です。交換の際は、指定部品以外は使用しないこと。
WARNING: 1. INDICATES SAFETY CRITICAL COMPONENTS. FOR CONTINUED SAFETY REPLACE SAFETY CRITICAL COMPONENTS ONLY WITH MANUFACTURER'S RECOMMENDED PARTS.

REPLACEMENT: 1. IN THIS COMPANION'S CIRCLES OF, SURETY, AND MANUFACTURER'S RECOMMENDED PARTS OR EQUIVALENTS IN THE REPAIR OF THE EQUIPMENT. IT IS THE RESPONSIBILITY OF THE REPAIRER TO DETERMINE THE FUNCTIONALITY OF THE PARTS TO BE REPLACED BY THE REPAIRER.

備考
C.R.の単位(特に指定された部品以外)
抵抗 C(1/6W(J))
コンデンサ μF(50V(J))
電圧は、GND間の電圧を基準として測定した値です。
NOTE
UNLESS OTHERWISE SPECIFIED
ALL RESISTORS IN OHMS (1/6W(J))
ALL CAPACITORS IN μF (50V(J))

GX-R88
SYSCON & TUNING(2/2)
SCHEMATIC DIAGRAM
NO. 6-3 840317A

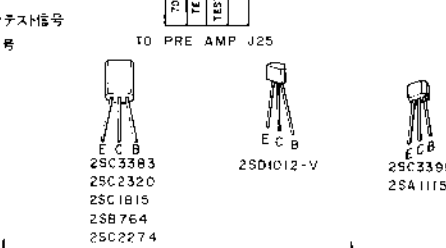

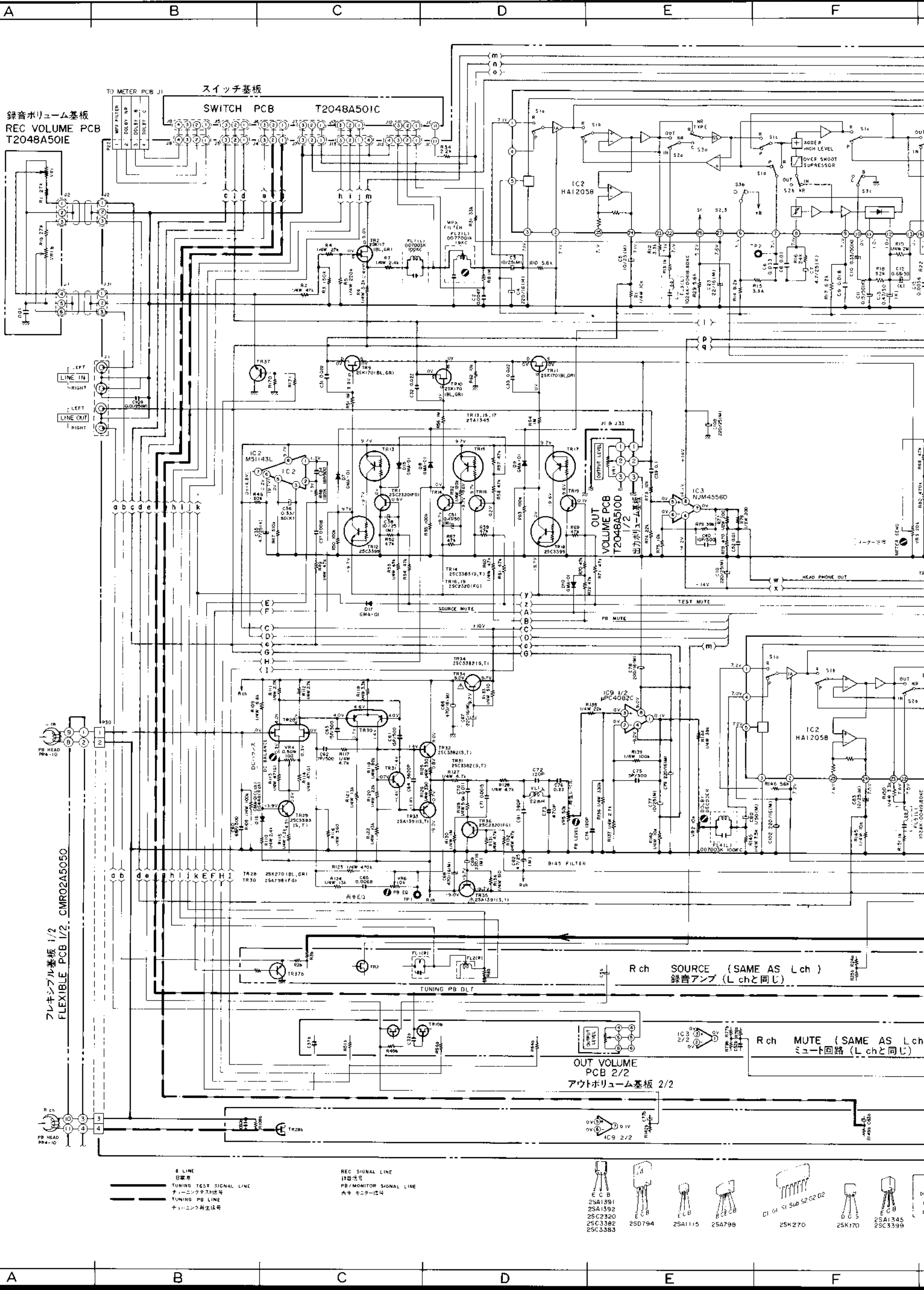

録音ボリューム基板
REC VOLUME PCB
T2048A501E

スイッチ基板
SWITCH PCB
T2048A501C

フレキシブル基板 1/2
FLEXIBLE PCB 1/2
CMR02A5050

出力ボリューム基板
OUT VOLUME PCB
T2048A5100
出力ボリューム基板 1/2

アウトボリューム基板 2/2
OUT VOLUME PCB 2/2
アウトボリューム基板 2/2

B LINE
目線
 TUNING TEST SIGNAL LINE
チューニングテスト線
 TUNING PB LINE
チューニング再生線
 REC SIGNAL LINE
録音信号線
 PB/MONITOR SIGNAL LINE
PBモニター線

IC B
25A1391
25A1392
25C2320
25C3382
25C3383
 D1
25D794
 E
25A1115
 F
25A798
 G1 G1 S1 S2 G2 G2
 H
25K270
 I
25K170
 J
25A1345
25C3399

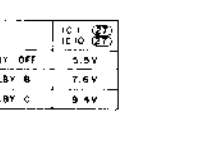
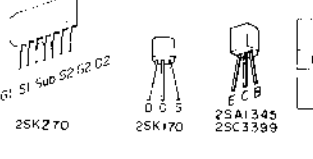
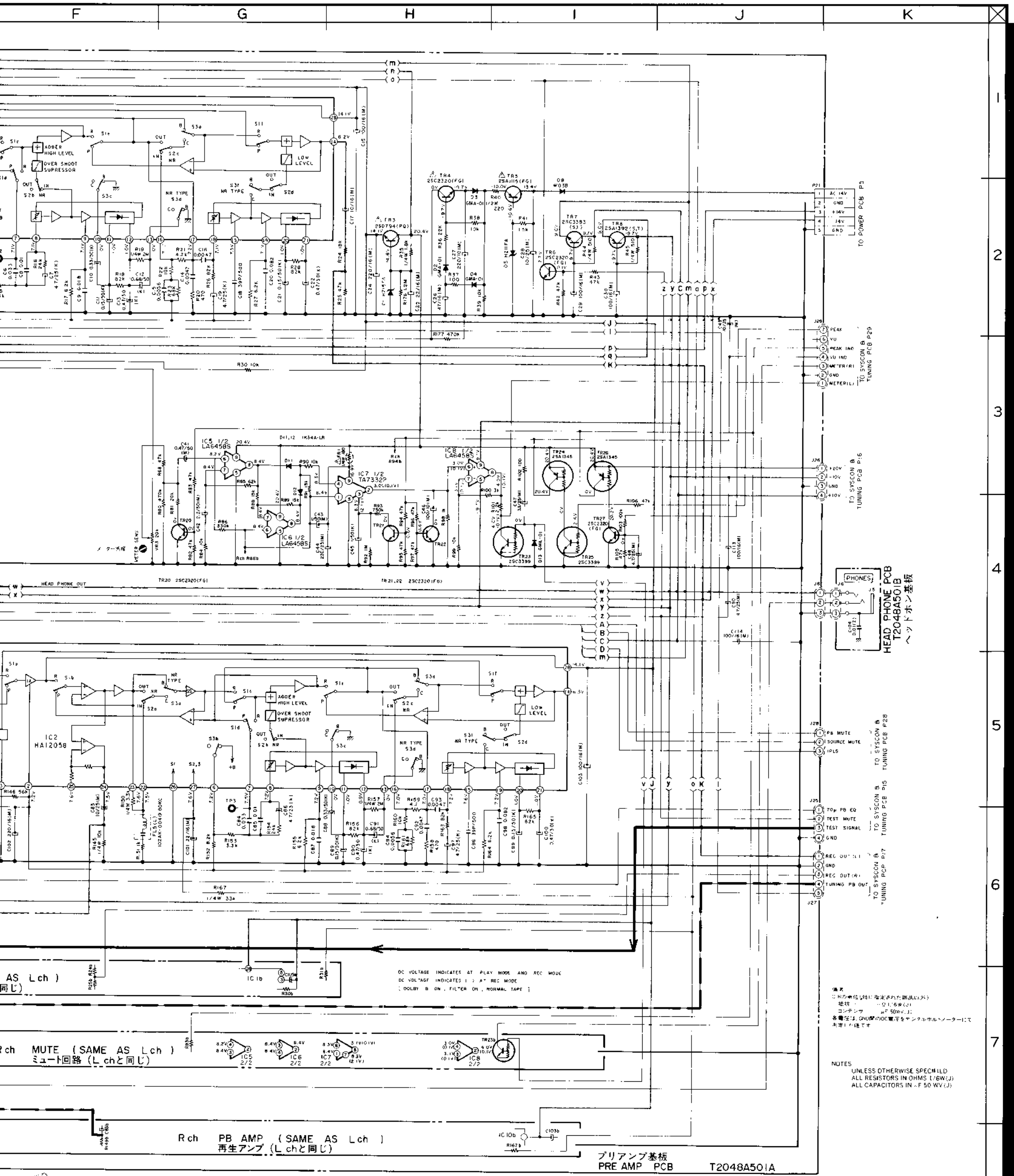

注意: 凡の付された部品は、安全上重要部品です。交換の際は、指定部品以外は使用しないこと。
WARNING: 凡の付された部品は、安全上重要部品です。交換の際は、指定部品以外は使用しないこと。
FOR CONTINUED SAFETY, REPLACE SAFETY CRITICAL COMPONENTS ONLY WITH MANUFACTURER'S RECOMMENDED PARTS.
 Avertissement: Les composants critiques de sécurité pour maintenir le fonctionnement sûr de l'appareil ne doivent être remplacés que par des pièces recommandées par le fabricant.

GX-R88 PRE AMP SCHEMATIC DIAGRAM

NO.6-4 831207B

備考
 □印の単位は、指定された数値以外
 抵抗: Ω, k, M, G
 コンデンサ: pF, nF, μF, 500μF, 1000μF
 各電圧は、GNDの0Vを基準とする。

NOTES
 UNLESS OTHERWISE SPECIFIED
 ALL RESISTORS IN OHMS (k, M, G)
 ALL CAPACITORS IN μF (500, 1000)

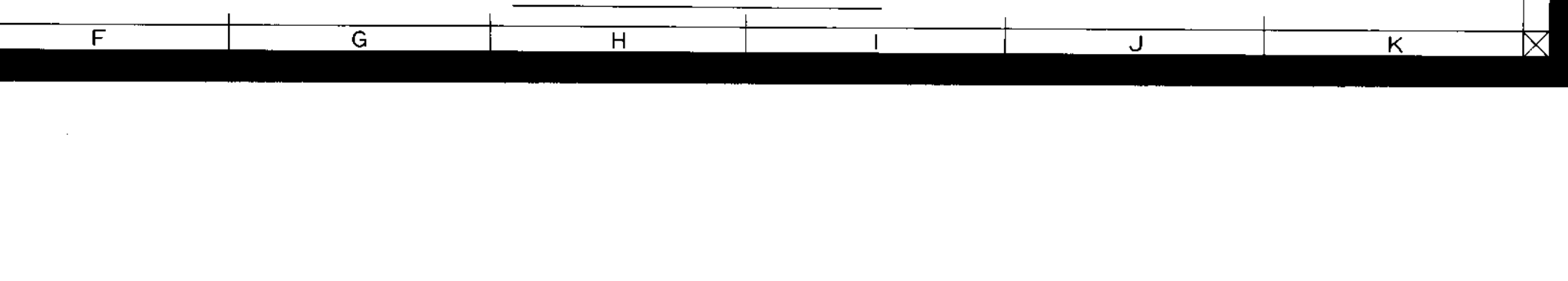

GX-R88

ポテンション基板
POTENTIOMETER PCB
M3105B501C

ホルダーリーフスイッチ基板
HOLDER REEF SW PCB
CMR02C5010

LED基板
LED PCB
CMR02D5020

ディテクター(L)基板
DETECTOR PCB (L)
CMR02D5040

ディテクター(R)基板
DETECTOR PCB (R)
CMR02D5030

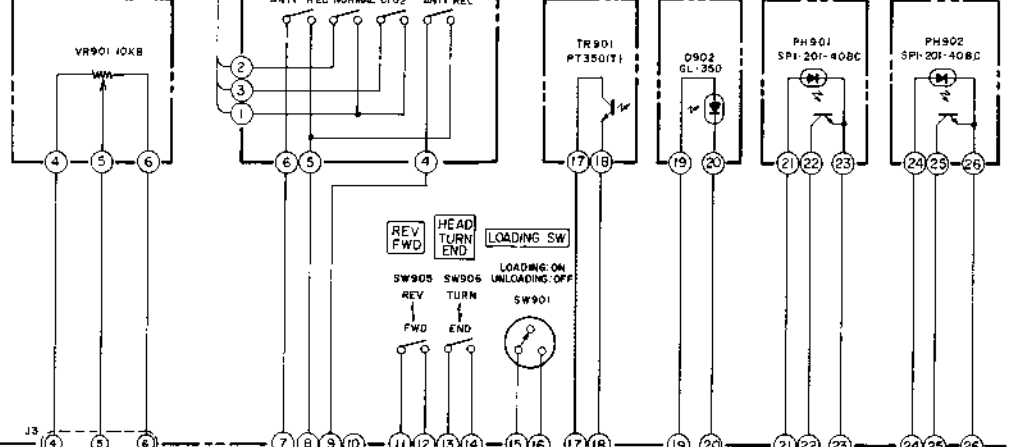

CONNECTOR A PCB
M3105B501D
コネクターA基板

注意: 上の付された部品は、安全上重要部品です。交換の際は、指定部品以外は使用しないこと。
WARNING: - INDICATES SAFETY CRITICAL COMPONENTS. FOR CONTINUED SAFETY, REPLACE SAFETY CRITICAL COMPONENTS ONLY WITH MANUFACTURER'S RECOMMENDED PARTS.
AVERTISSEMENT: IL INDOIT LES COMPOSANTS CRITIQUES DE SURETE POUR MAINTENIR LE DEGRÉ DE SECURITE DE L'APPAREIL. NE REMPLACER LES COMPOSANTS DONT LE FONCTIONNEMENT EST CRITIQUE POUR LA SECURITE QUE PAR DES PIÉCES RECOMMANDÉES PAR LE FABRICANT.

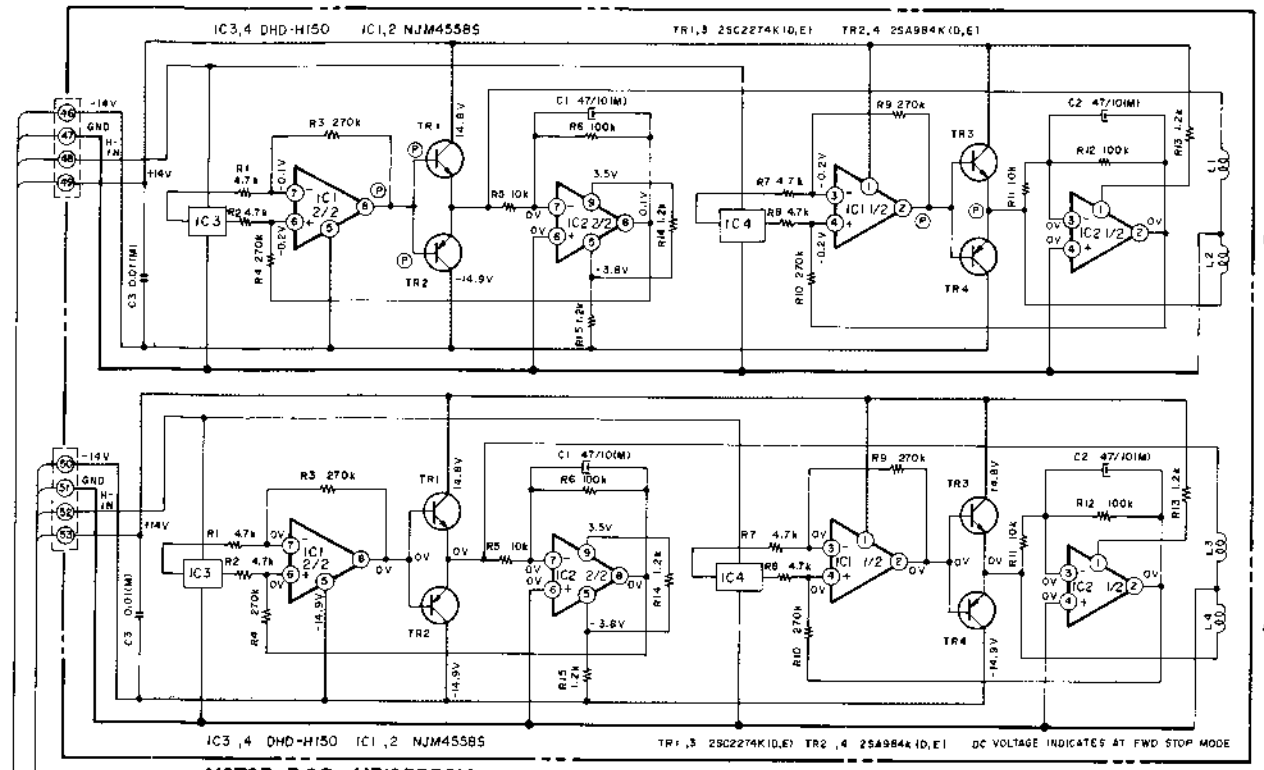

MOTOR PCB M3105B501A
モーター基板

サーボ基板
SERVO PCB M3105B501B

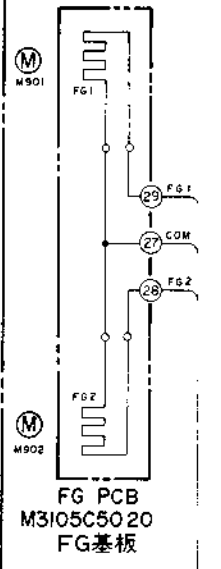

FG PCB
M3105C5020
FG基板

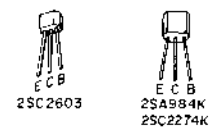

B LINE
B線
DC VOLTAGE INDICATES AT STOP MODE

NOTE
UNLESS OTHERWISE SPECIFIED
ALL RESISTORS IN OHMS 1/4W(J)
ALL CAPACITORS IN μ F 50WV(J)
POWER TRANSFORMER IS DIFFERENT
ACCORDING TO AREA
備考
C.R.の単位(特に指定された部品以外)
抵抗: Ω 1/4W(J) (F.S.)記号は不燃性部品
コンデンサ: μ F 50WV(J)
各電圧は、GNDからのDC電圧をシングルポルトモーターにて
測定した値です。

GX-R88 MECHA
SCHEMATIC DIAGRAM
NO.6-5 831208B

サーボ基板
SERVO PCB
M3105B501B

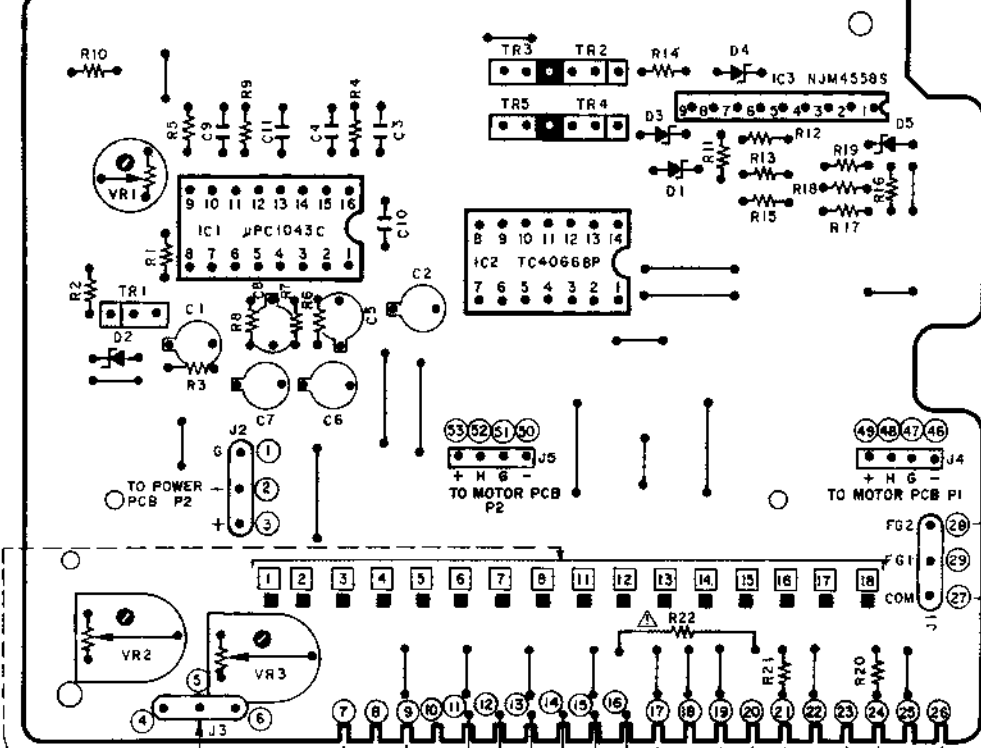

TR1-----2SC2603(E,F)
TR2,4-----2SC2274K(D,E)
TR3,5-----2SA984K(D,E)

VR1-----TAPE SPEED
ADJUSTMENT
VR2-----HIGH VOLTAGE
ADJUSTMENT
VR3-----LOW VOLTAGE
ADJUSTMENT

TO MOTOR PCB P2
TO MOTOR PCB P1
TO FG PCB
TO DETECTOR(L)
TO DETECTOR(R)

2SA984K
2SC2274K

ECB
ECB

ANTIREC SW SW904
SW905 SW906 SW901
LED
DS902

TO DETECTOR(L)
TO DETECTOR(R)

● NPN TRANSISTOR
■ PNP TRANSISTOR

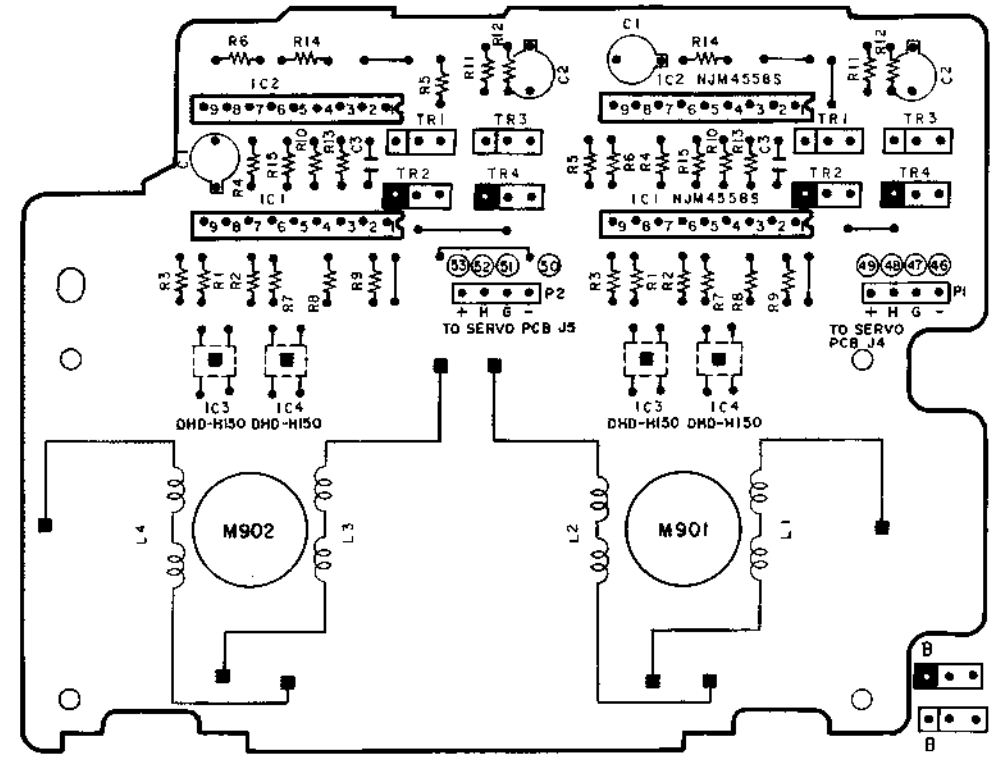

TR1,3
--2SC2274K(D,E)
TR2,4
2SA984K(D,E)

ECB
2SC2274K
2SA984K

PNP TRANSISTOR
NPN TRANSISTOR

(CAPSTAN) MOTOR PCB M3105B501A
モーター基板

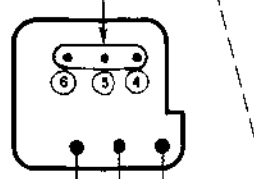

POTENTION PCB
M3105B501C
ポテンション基板

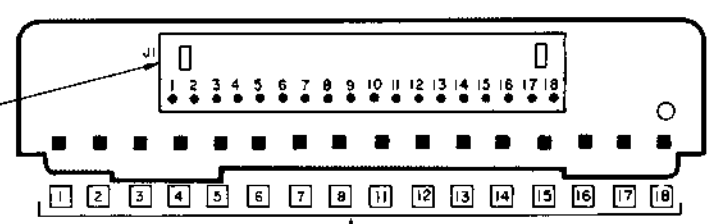

コネクターA基板
CONNECTOR A PCB
M3105B501D

注意: ①の付された部品は、安全上重要部品です。交換の際は、指定部品以外は使用しないこと。
WARNING: ① INDICATES SAFETY CRITICAL COMPONENTS. FOR CONTINUED SAFETY, REPLACE SAFETY CRITICAL COMPONENTS ONLY WITH MANUFACTURER'S RECOMMENDED PARTS.
AVERTISSEMENT: ① IL INDIQUE LES COMPOSANTS CRITIQUES DE SURETÉ. POUR MAINTENIR LE DEGRÉ DE SÉCURITÉ DE L'APPAREIL, NE REMPLACER LES COMPOSANTS DONT LE FONCTIONNEMENT EST CRITIQUE POUR LA SÉCURITÉ QUE PAR DES PIÈCES RECOMMANDÉES PAR LE FABRICANT.

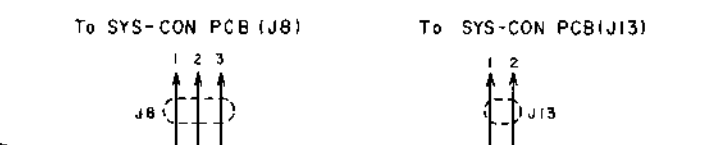

コネクターB基板
CONNECTOR B PCB
T2048A504D

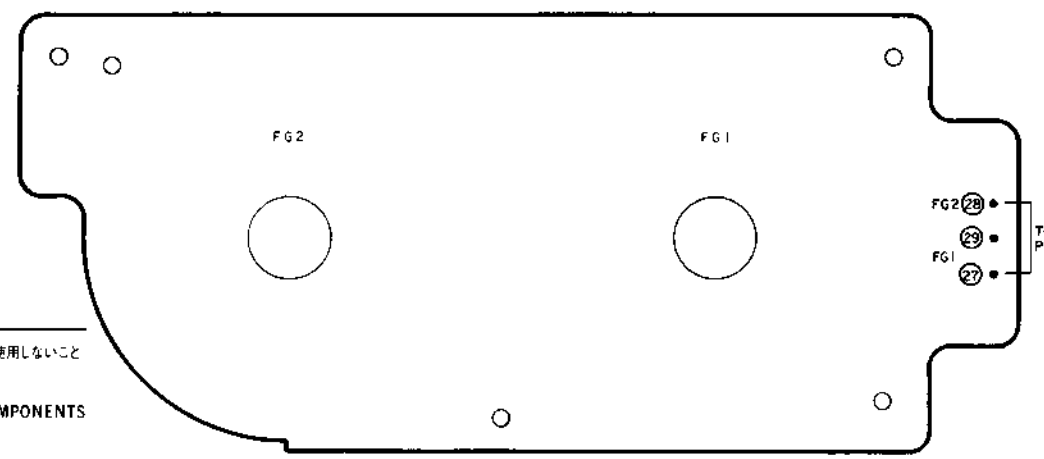

FG PCB M3105C5020
FG基板

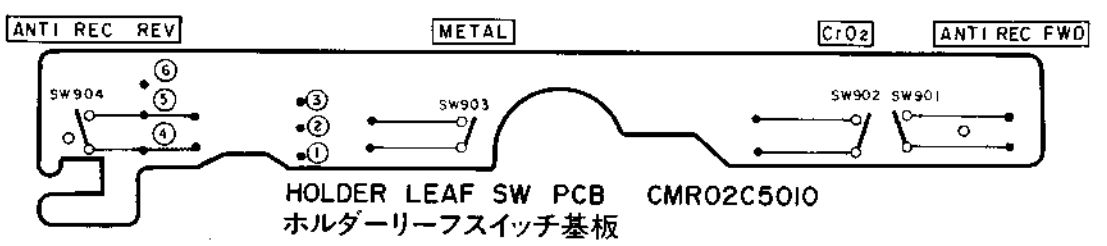

HOLDER LEAF SW PCB CMR02C5010
ホルダーリーフスイッチ基板

GX-R88

TO PRE-AMP PCB P22

MPX FILTER
DOLBY NR
DOLBY (B)
DOLBY (C)

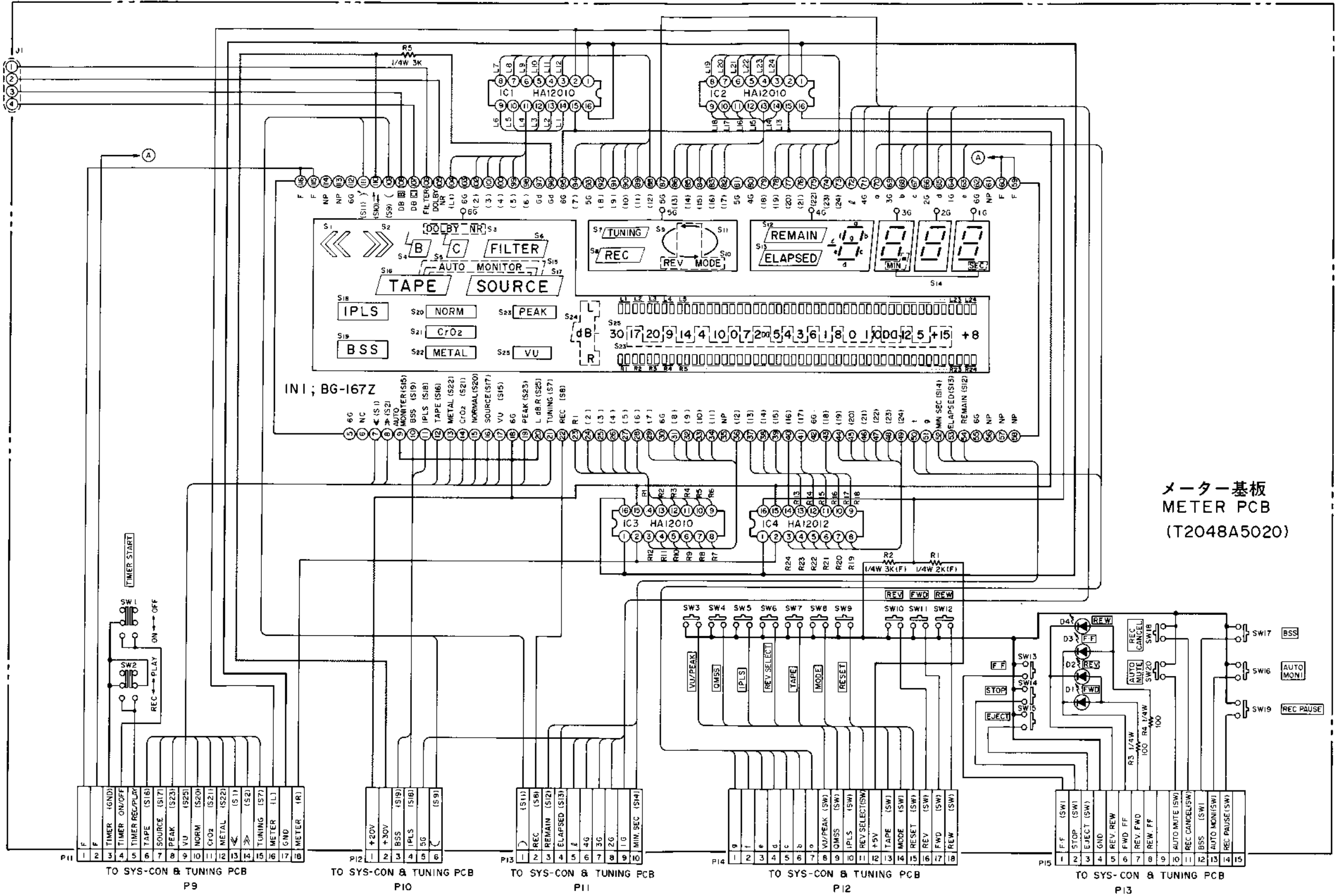

— B (POWER SUPPLY) LINE
- - - 電源

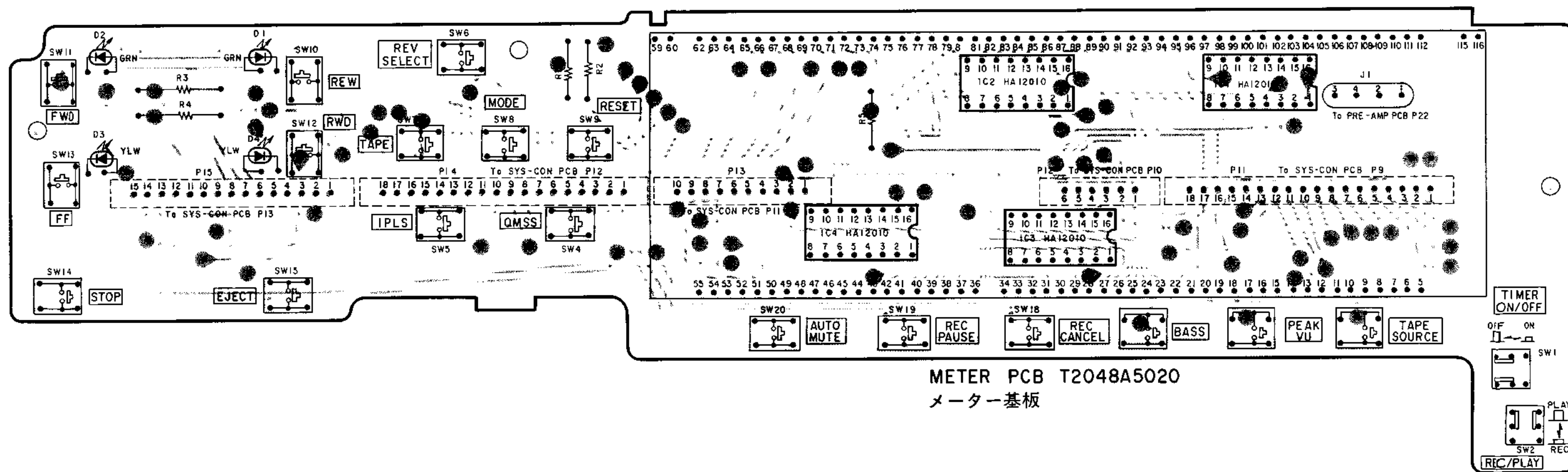

METER PCB T2048A5020
メーター基板

DOLBY C "ON" REC MODE (ドルビーC録音)

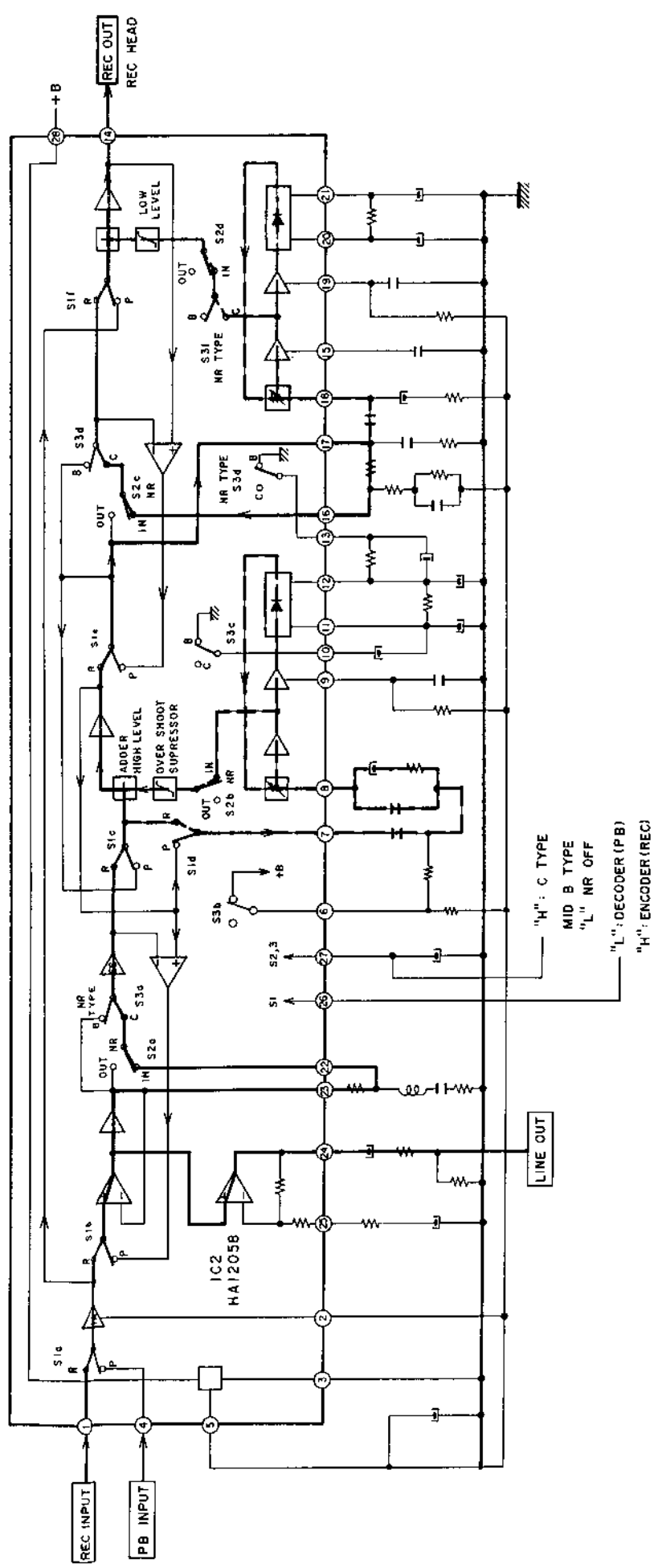

DOLBY C P.B MODE (ドルビーC再生)

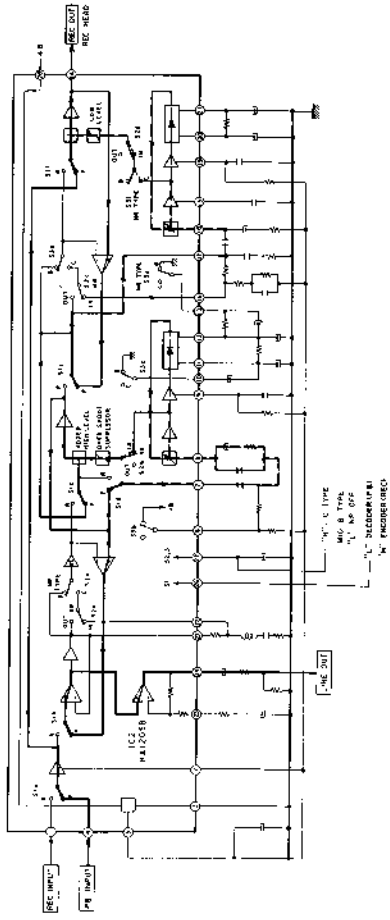

DOLBY B REC MODE (ドルビーB録音)

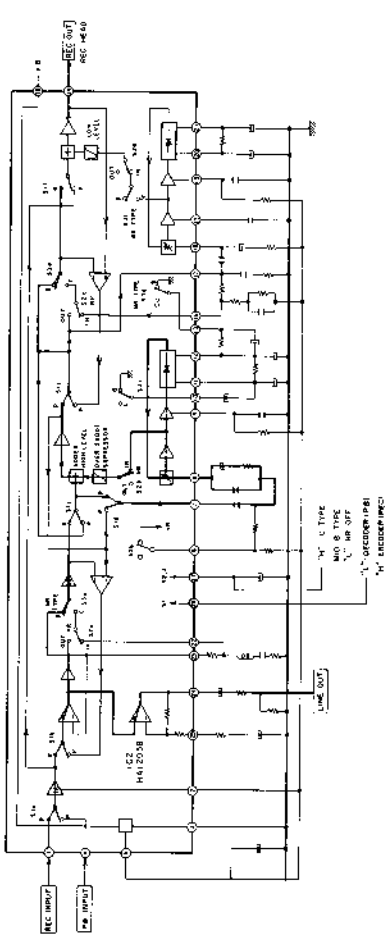

DOLBY B P.B MODE (ドルビーB再生)

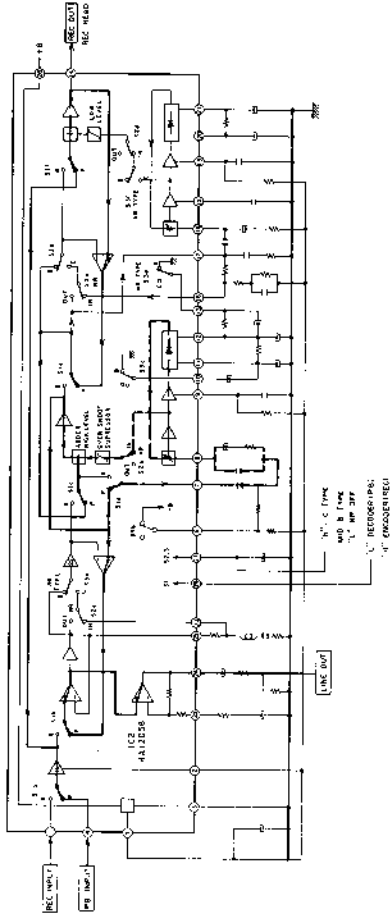

DOLBY "OFF" REC MODE (ドルビーOFF録音)

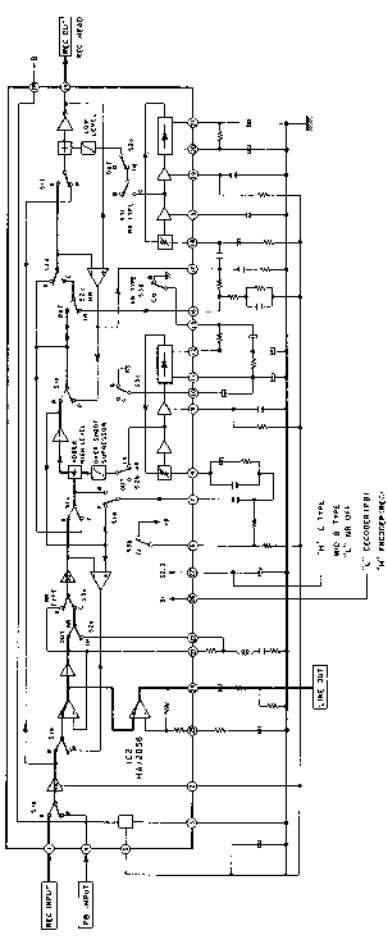

DOLBY "OFF" P.B MODE (ドルビーOFF再生)

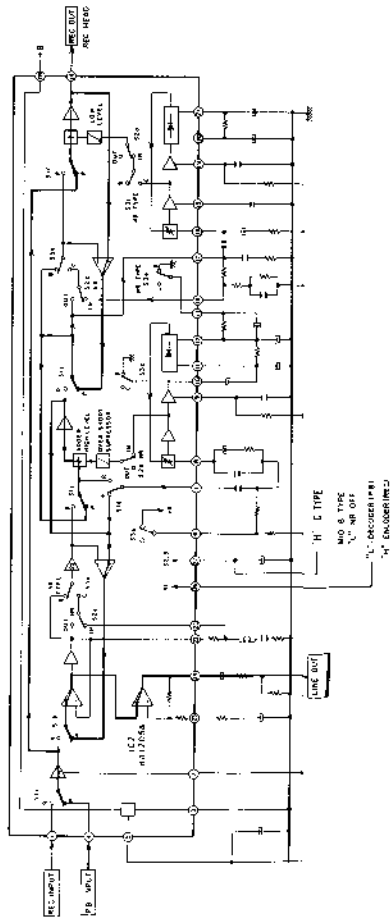

DOLBY IC (HA12038
HA12058)
SIGNAL LINE

Da dieses Wartungshandbuch bereits auf Englisch veröffentlicht ist und Einstell- und Zeichnungshinweise auf Deutsch enthält, empfiehlt es sich, diese Ausgabe des Handbuchs zusammen mit der bereits veröffentlichten englischen Ausgabe und den Stromlaufplänen zu verwenden.

STEREOCASSETTENECK

MODEL GX-R88

I. TECHNISCHE DATEN

Spursystem Kompaktcassette, Stereo
 Motoren FG-Servo-Direktantriebs-
 motor für Tonrollentrieb x 2
 Gleichstrommotor für Spulen-
 trieb x 2
 Gleichstrommotor für Antrieb
 des Mechanismus x 1
 Tonköpfe Super-GX-Kopf für Aufnahme
 x 1
 Super-GX-Kopf für Wiedergabe
 x 1
 Löschkopf x 2
 Gleichlaufschwankungen .. 0,028% (WRMS), 0,08% WTD (DIN)
 Bandumspulzeit 90 Sek. (mit einer C-60
 Cassette)
 Verzerrung 0,5% (Reineisen)
 Frequenzgang Reineisen 20Hz bis 21000Hz
 + 3dB
 Chrom 20Hz bis 19000Hz
 + 3dB
 Normal 20Hz bis 18000Hz
 + 3dB

Rauschabstand Reineisen 60dB
 Mit Dolby Typ C:
 Verbessert bis zu
 15dB bei 500Hz,
 20dB bei 1 kHz bis
 10kHz
 Mit Dolby Typ I:
 Verbessert bis zu
 5dB bei 1kHz, 10dB
 oberhalb 5kHz
 Eingang LINE IN 70mV/47kOhm
 Ausgang LINE OUT 410mV/250 Ohm
 PHONES 1,3mW/8 Ohm
 Stromversorgung 120V, 60Hz für USA & Kanada
 220V, 50Hz für Europa auschl.
 GB
 240V, 50Hz für GB &
 Australien
 110/120/220/240V, 50/60Hz,
 umschaltbar für andere Länder
 Abmessungen 440(B) x 105(H) x 372(T) mm
 Gewicht 7,6kg

* Änderungen der technischen Daten und des Designs
 zum Zwecke der Verbesserung vorbehalten.

II. SICHERHEITSHINWEISE

SICHERHEITSKONTROLLE NACH WARTUNGSARBEITEN

Sicherstellen, daß der vorgegebene Isolierwiderstand zwischen den Stifen des Netzkabelsteckers und den äußeren, freiliegenden Gehäuseteilen mehr als 10 MOhm beträgt; hingegen soll bei Geräten mit Klemmen für Außenantennen (Tuner, Receiver usw.), die für [C] oder [A] vorgesehen sind, der vorgegebene Isolierwiderstand mehr als 2,2 MOhm (Erdungsklemmen, Mikrofonbuchsen, Kopfhörerbuchsen, (Line-in-out-Buchsen usw.) betragen.

BEI WARTUNGSARBEITEN ZU BEACHTENDE VORSICHTSMASSNAHMEN

1. Bei mit dem Symbol markierten Teilen sind die Sicherheitsvorschriften besonders sorgfältig zu beachten.
Den Austausch nur gegen Teile mit vorgeschriebener Teilenummer vornehmen.
2. Abgesehen von Sicherheitsmarkierungen werden sonstige Teile und Einheiten spezifiziert im Hinblick auf Übereinstimmung mit Regelungen, wie z.B. für Nebenausstrahlung, auch solche Teile dürfen nur gegen vorgeschriebene Austauschteile ausgetauscht werden.
Beispiele: Hf-Umsetzer, Tunereinheiten, Antennenwahlschalter, Hf-Kabel, rausch unterdrückende Kondensatoren, rauschunterdrückende Filter usw.
3. Die vorgeschriebene interne Verdrahtung verwenden. Insbesondere auf Folgendes achten:
 - 1) mit PVC-Kabelschutzrohr versehene Leitungen
 - 2) doppelt isolierte Leitungen
 - 3) Hochspannungsleitungen
4. Für Teile, die gefährlich hohe Spannungen führen, nur die vorgeschriebenen Isoliermaterialien verwenden. Dabei ist besonders zu achten auf:
 - 1) Isolierband
 - 2) PVC-Kabelschutzrohr
 - 3) Abstandhalter (Isoliersperren)
 - 4) Isolierfolien für Transistoren
 - 5) Plastikschrauben zur Befestigung von Mikroschaltern (insbesondere bei Plattenspielern)
5. Beim Austauschen von Komponenten auf der Netzspannung-Primärseite (Transformatoren, Netzkabel, rauschunterdrückende Kondensatoren usw.) sind die Kabelenden vor dem Verlöten vorschriftsmäßig um die Klemmen zu wickeln.

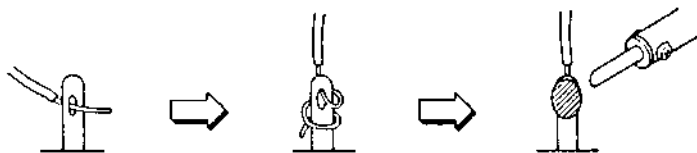

6. Darauf achten, daß Leitungen nicht in Kontakt mit wärmeproduzierenden Teilen geraten (z.B. Kühlkörpern, Metalloxidfolien-Widerständen, unterbrechbaren Widerstände usw.)
7. Sicherstellen, daß beim Austausch von Leitungen diese nicht in Kontakt mit scharfen Kanten oder spitzen Teilen geraten.
8. Desgleichen die Bereiche in der Umgebung von Stellen, an denen repariert wurde, überprüfen.
9. Darauf achten, daß keine Fremdkörper (Schrauben, Lot usw.) innerhalb des Gerätes verbleiben.

III. SPANNUNGSMUMSTELLUNG

3-1 SPANNUNGSMUMSTELLUNG

Modelle für Kanada, USA, Europa, Großbritannien und Australien sind nicht mit dieser Einrichtung ausgestattet. Jedes Gerät wird im Werk dem Bestimmungsort entsprechend eingestellt. Manche Geräte können aber, falls notwendig, auf 110V, 120V, 220V oder 240V umgestellt werden. Falls die Spannung des Geräts umgeschaltet werden kann:

1. Netzkabel herausziehen.
2. Den Spannungswähler (VOLTAGE SELECTOR) auf der Geräterückseite mit einem schraubenzieher so drehen, daß die korrekte Netzspannung angezeigt wird.

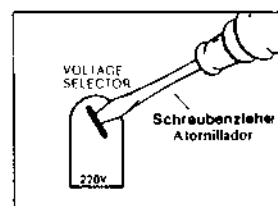

V. MECHANISCHE EINSTELLUNG

5-1 MESSUNG DES ANDRUCKROLLENDRUCKS (Siehe Abb. 5-1)



Abb. 5-1

Das Gerät auf FWD PLAY schalten. Die Andruckrollenwelle mit der Federwaage so herunterdrücken, daß ein Abstand von 1~2 mm zwischen Andruckrolle und Capstan entsteht. Anschließend den Druck vermindern, bis sich die Andruckrolle wieder zu drehen beginnt. In diesem Zustand den Wert ablesen. Der vorgeschriebene Andruck beträgt.

RECHTE SEITE: 450 ± 80 g
 LINKE SEITE: 400 ± 80 g

Sicherstellen, daß der Andruckrollendruck bei REV PLAY

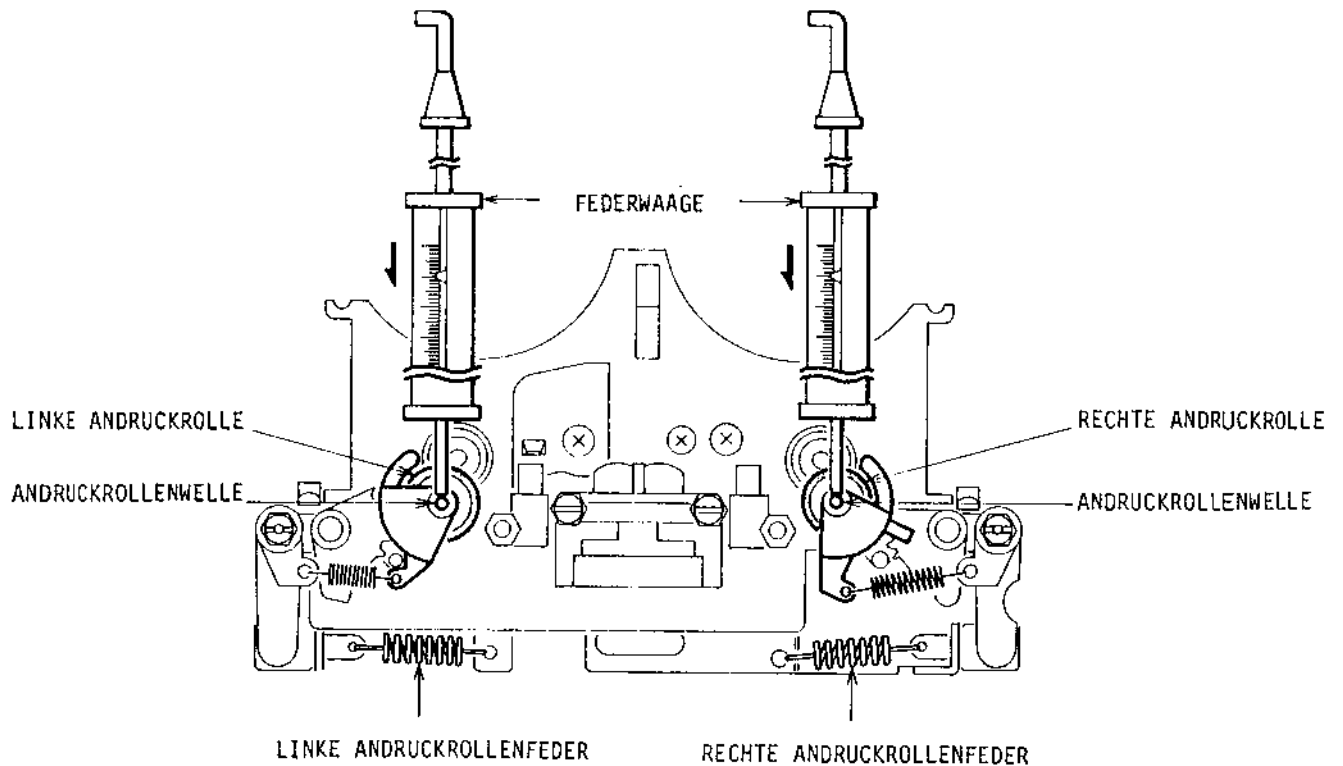
RECHTE SEITE: 400 ± 80 g

LINKE SEITE: 450 ± 80 g

beträgt. Falls dieser Wert nicht erreicht wird, ist die Andruckrollenfeder auszutauschen.

5-2 WICKEL-DREHMOMENT IN ALLEN BETRIEBSARTEN (Siehe Abb. 5-2)

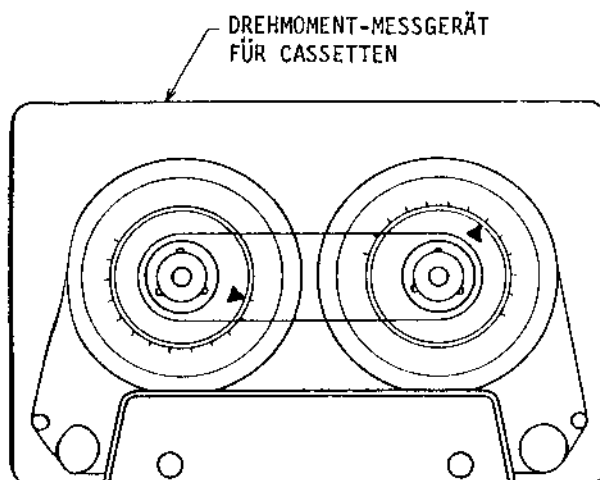

Ein Cassetten-Drehmoment-Meßgerät (AJ-751179) einlegen und die Messung in allen Betriebsarten durchführen. Die Messung des schnellen Vor- und Rücklaufs am Bandende d.h. nach Stoppen des Bandlaufs ausführen.

Vorlauf- oder Reverse-Betriebsart

Aufwickeldrehmoment: $40 \begin{matrix} +15 \\ -10 \end{matrix}$ g-cm

Abwickelzug-Drehmoment: 17 ± 3 g-cm

Betriebsart Schneller Vor und Rücklauf

Aufwickeldrehmoment: $100 \begin{matrix} +50 \\ -30 \end{matrix}$ g-cm

Abb. 5-2

5-3 EINSTELLUNG DES REGLERS (VR901) UND DES KURVENRADES (Siehe Abb. 5-3)



Abb. 5-3



- 1) Einstellung des Positionsreglers (Potentio-Antriebszahnrad)
Das rechte Ende von Marke (A) wie in der Zeichnung gezeigt mit der Mitte von Marke (B) ausrichten. (Abb. 5-3 ①)
- 2) Auf die mit "X" markierten Teile Molybdän Schmiermittel auftragen. (Abb. 5-3 ②)
- 3) Das Kurvenrad auf dem Capstanhalter (A) anbringen. Wenn das Kurvenrad korrekt angebracht ist, stimmt die Mitte von Marke (D) mit dem rechten Ende von Marke (C) überein. (Abb. 5-3 ③)
- 4) Den Federring in die Rille des Capstanhalters einsetzen.
- 5) Das Kurvenrad (R) auf dem Capstanhalter (B) anbringen. Wenn das Kurvenrad (R) korrekt positioniert ist, stimmt die Mitte von Marke (E) mit der Mitte von Marke (F) überein. (Abb. 5-3 ④)

5-4 ABGLEICH DER VORGEgebenEN POTENTIOMETER-SPANNUNG (Siehe Abb. 5-4 bis 5-8)

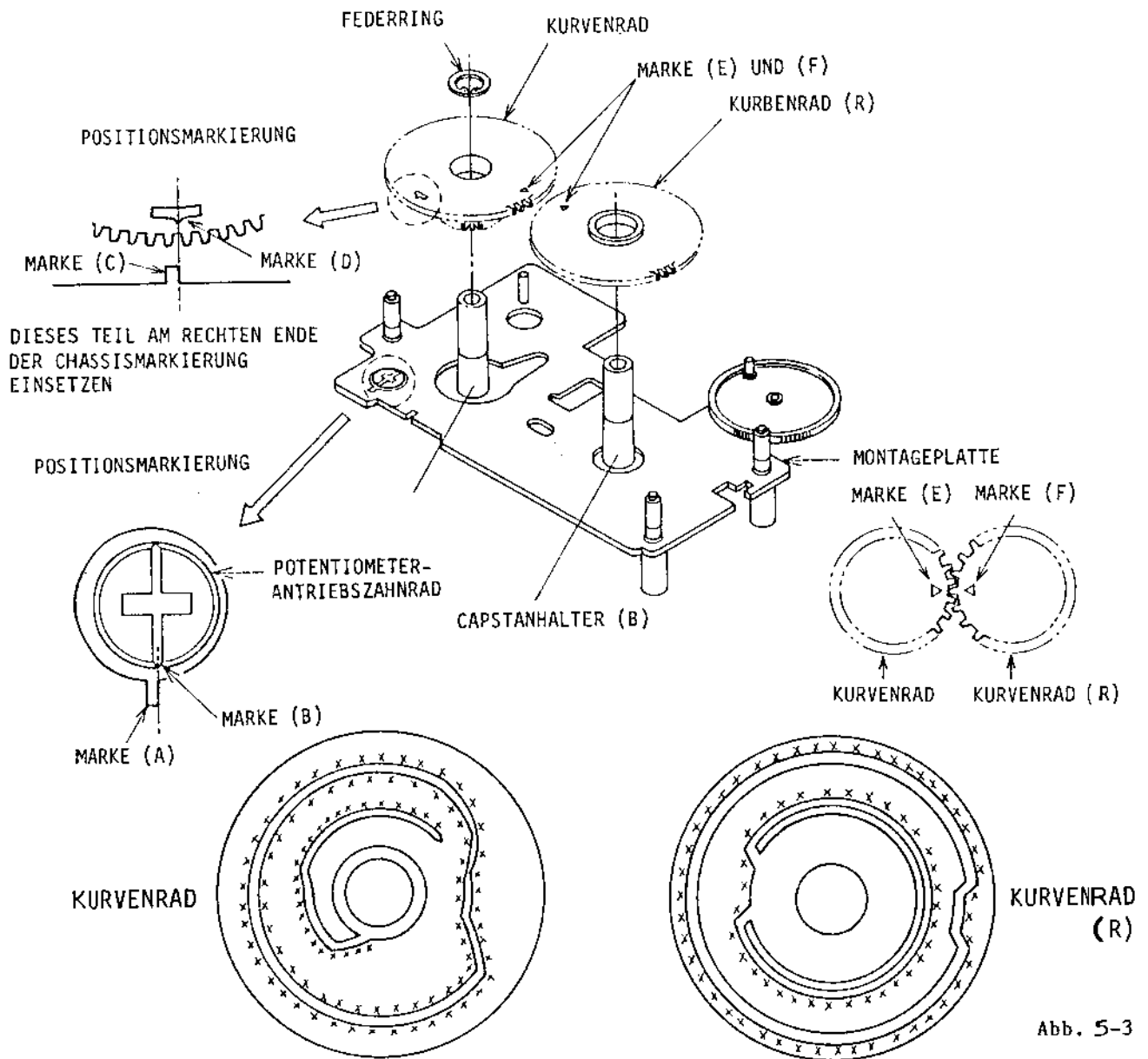
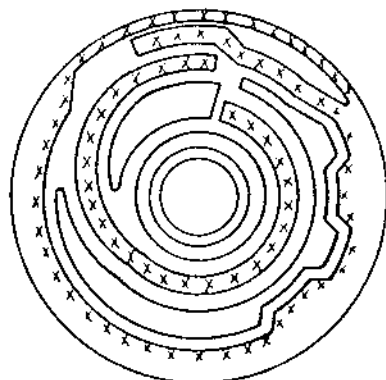

Abb. 5-4



Abb. 5-5

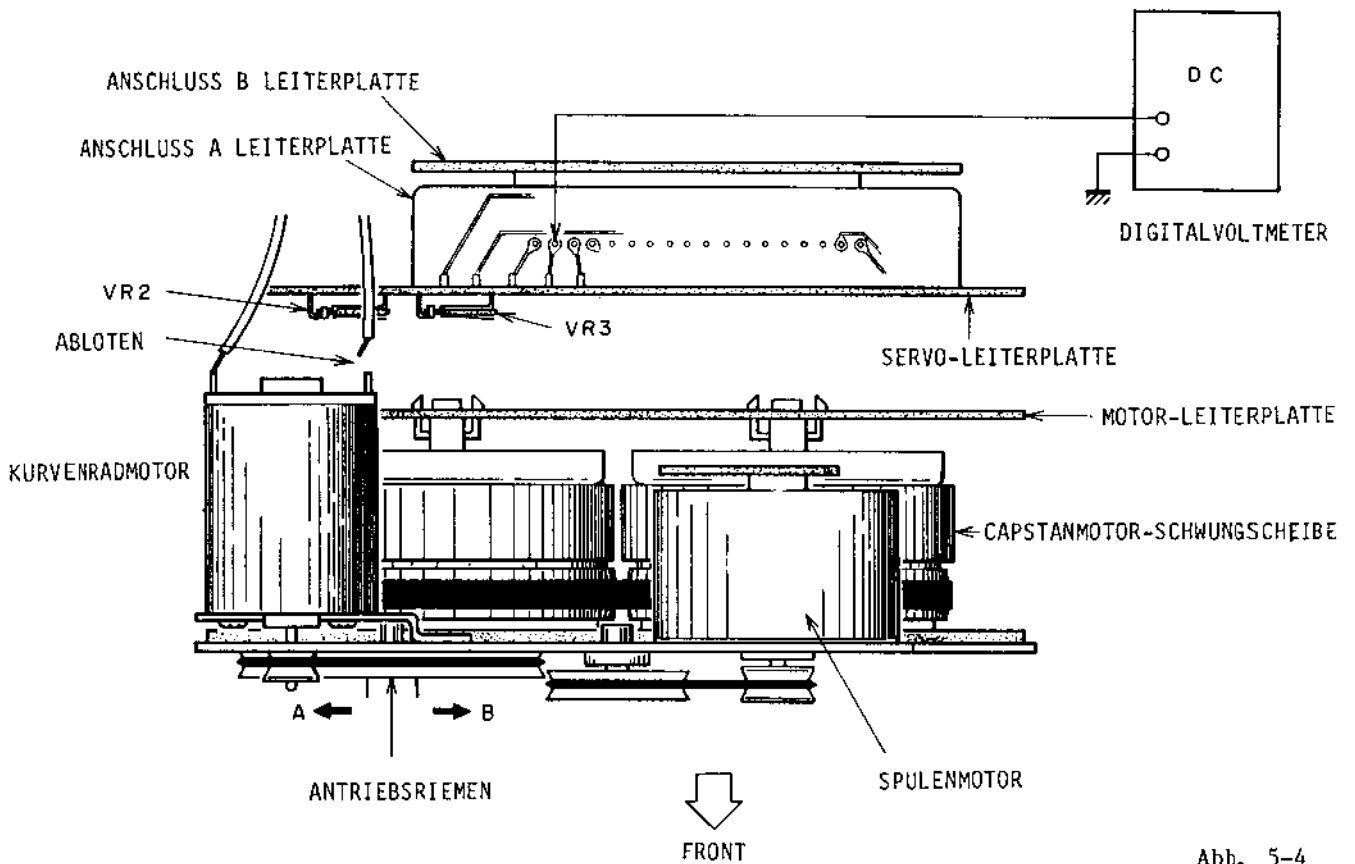

Abb. 5-6

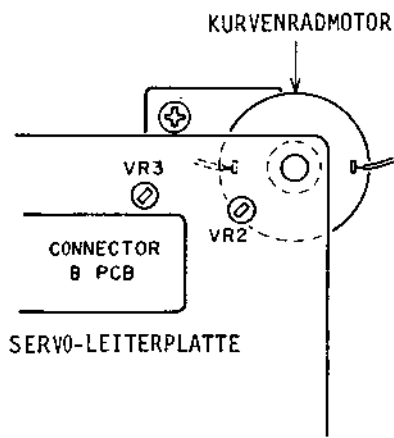

Abb. 5-7

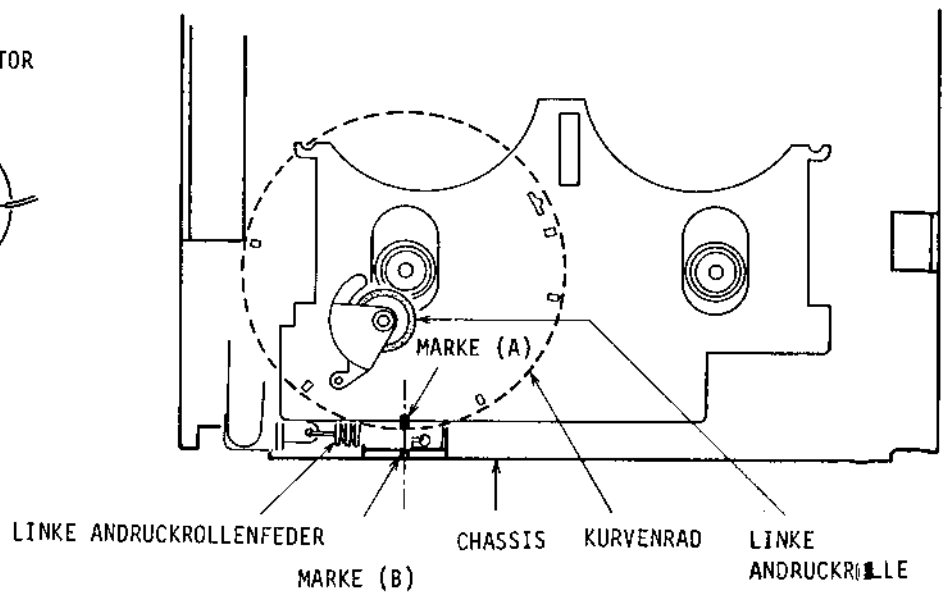

Abb. 5-8

- 1) ABGLEICH DER NIEDERSPANNUNG
(Siehe Abb. 5-4 und Abb. 5-5)
 - a. Bei ausgeschalteter Stromversorgung das Anschlußkabel vom Kurvenradmotor ablösen und den Antriebsriemen mit dem Finger so weit wie möglich in Richtung A drehen.
 - b. Das Digitalvoltmeter wie in Abb. 5-4 gezeigt anschließen.
 - c. Bei eingeschaltetem Gerät VR3 so abgleichen, daß die abgelesene Spannung $1,255 \pm 0,05$ V beträgt.
- 2) ABGLEICH DER HÖCHSTSPANNUNG
(Siehe Abb. 5-4 und Abb. 5-5)
 - a. Bei abgeschaltetem Gerät den Antriebsriemen mit den Fingern bis zum Anschlag in Richtung B drehen.
 - b. Bei eingeschaltetem Gerät VR2 so einstellen, daß die abgelesene Spannung $9,22 \pm 0,01$ V beträgt.
- 3) Die Abschnitte 1) und 2) wiederholen.
- 4) a. Bei ausgeschalteter Stromversorgung das Anschlußkabel des Motors anschließen.
b. Das Digitalvoltmeter abtrennen.
c. Die Schrauben (a) bis (f) in Abb. 5-6 entfernen und den gesamten Mechanikblock leicht herausziehen.
- 5) a. Das Gerät einschalten.
b. VR2 etwas verstellen, so daß in der STOP-Betriebsart die Mitte der Marke (A) mit der Mitte der Marke (B) übereinstimmt (die Spannung in der STOP-Betriebsart beträgt ca. 7,35 V, wenn die Versorgungsspannung an (1) in Abb. 5-4 9,75 V beträgt.)
c. Den Cassettendeckel entfernen und mit dem AUTO SYSTEM-Schalter die IPLS-Betriebsart einschalten.
d. Sicherstellen, daß bei abwechselndem Drücken der Vorlauf- und Rücklauf-tasten der Tonkopf nicht auf- und abbewegt wird.
e. Mit den Fingern die Spule in der STOP-Betriebsart drehen, um sicherzustellen, daß die Bremse zufriedenstellend arbeitet.
Wenn die Bremse normal funktioniert, dreht sich die Aufwickelspule nicht im Uhrzeigersinn und die Abwickelspule nicht gegen den Uhrzeigersinn.

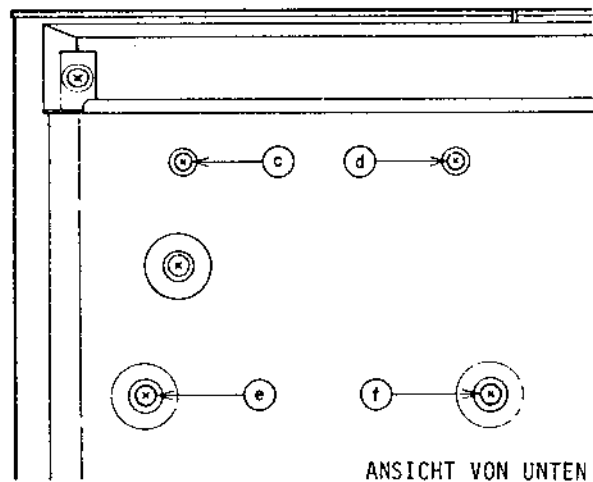
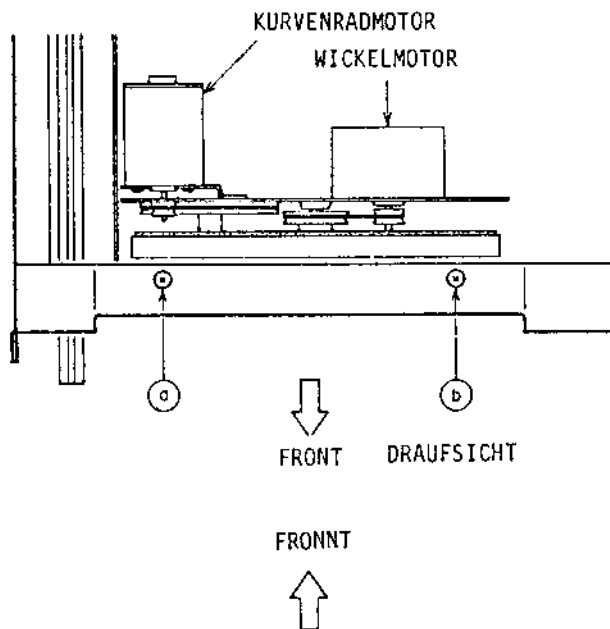
5-5 EINSTELLUNG DER BANDGESCHWINDIGKEIT (Siehe Abb. 5-9)

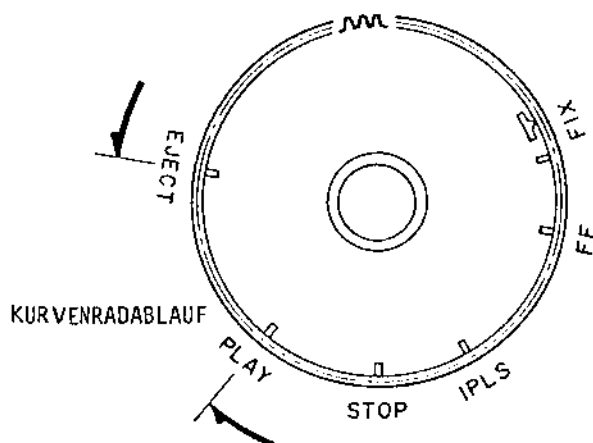

Abb. 5-9

Einen Frequenzzähler an die Line-Ausgang anschließen. Eine bespielte 1000Hz-Test-cassette (AT-750774) abspielen und den Bandgeschwindigkeits-Einstellregler (SERVO LEITERPLATTE) so einstellen, daß eine Frequenz von 995 bis 1005 Hz erreicht wird.

VI. TONKOPFEINSTELLUNG

6-1 EINSTELLUNG DER BANDFÜHRUNGSHÖHE (Siehe Abb. 6-1 und 6-2)

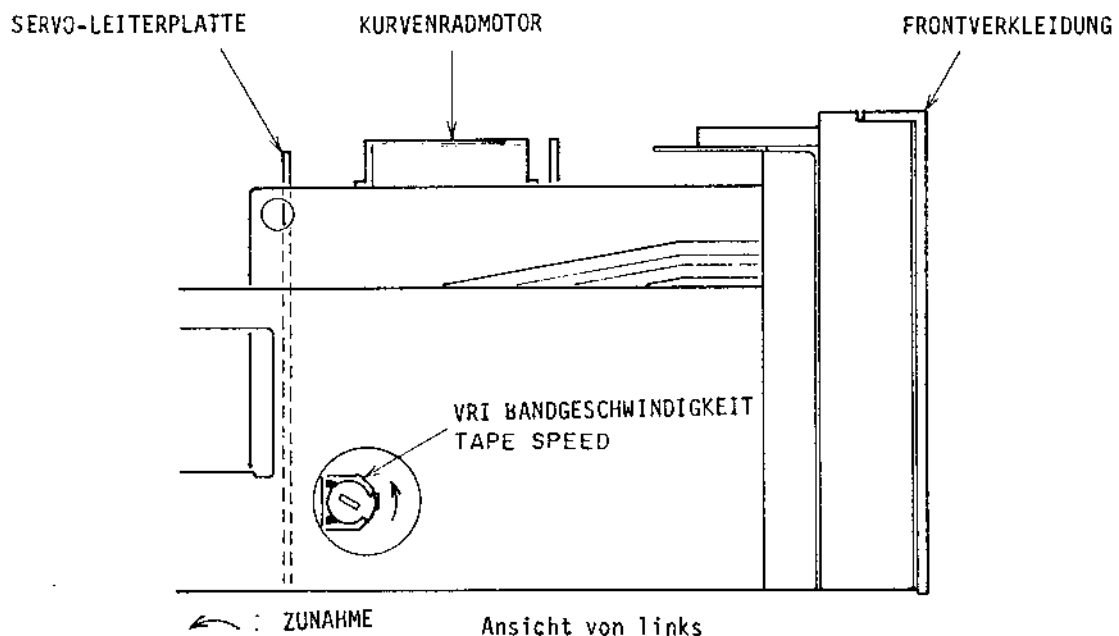

Abb. 6-1



Abb. 6-2

6-1-1 Nach Austausch des Andruckrollenblocks

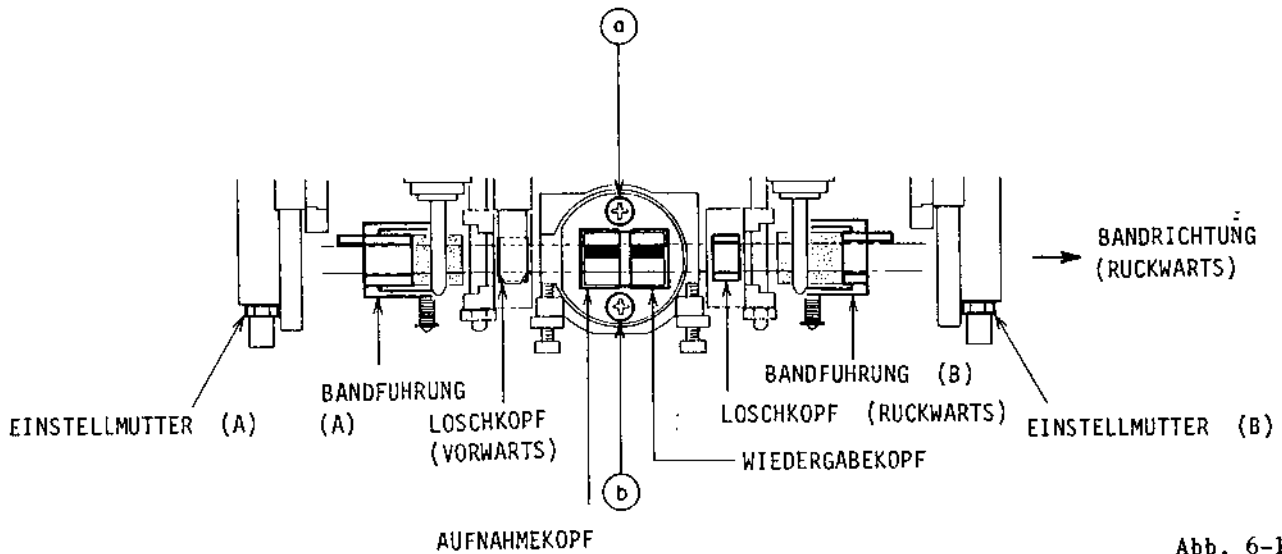
- a) Eine Spiegelcassette (AJ-751178) einlegen.
- b) Wenn nur der Andruckrollenblock (L) ausgetauscht worden ist, wählt man die Betriebsart FWD PLAY und stellt die Höhe der Bandführung (A) durch Drehen der Mutter (A) so ein, daß das Band am angrenzenden Rand beider Bandführungen reibungslos läuft und das Band keinerlei Verformungen aufweist.
- c) Wenn nur der Andruckrollenblock (R) ausgetauscht wurde, wählt man die Betriebsart REV PLAY und stellt die Höhe der Bandführung (B) durch Drehen der Mutter (B) in der gleichen Weise wie im Abschnitt b) ein.
- d) Nach der Einstellung Siegelack auf diese Muttern auftragen.

6-1-2 NACH AUSTAUSCH DES LÖSCHKOPFES

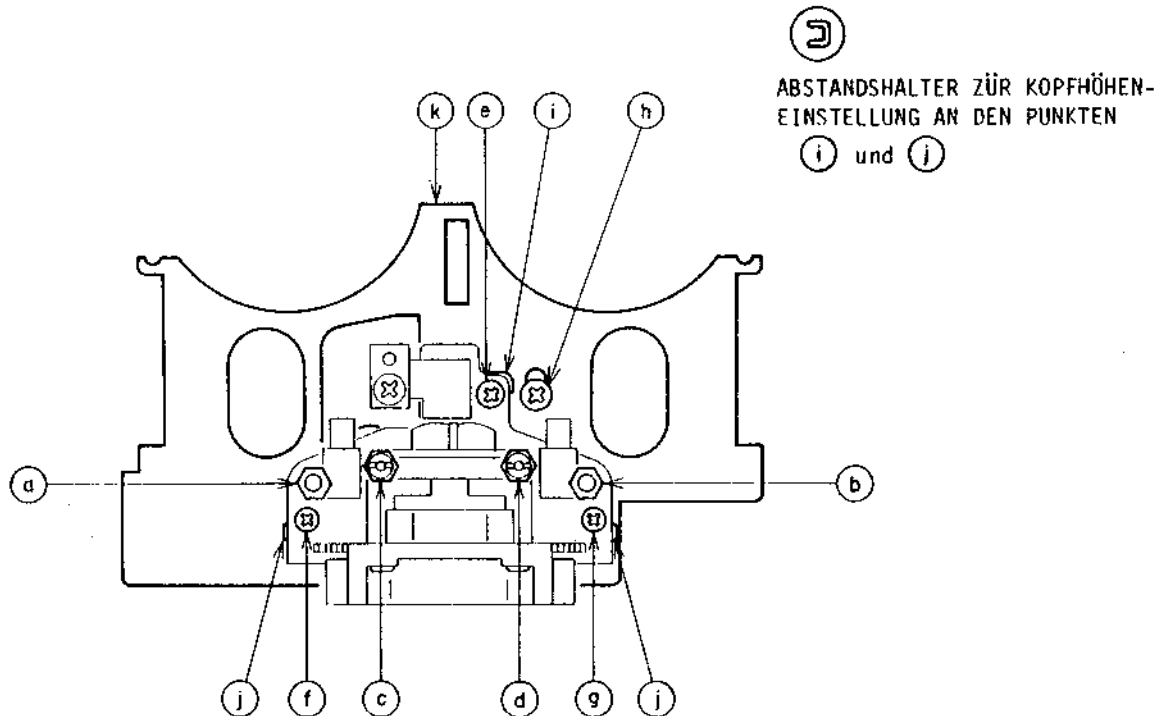
(Siehe Abb. 6-1 und 6-2)

- a) Eine 315 oder 333 Hz Wiedergabepegel-Einstellcassette (AT-750773) einlegen und die Betriebsart FWD PLAY wählen.
 - b) Die Löschkopfhöhe durch Drehen der Muttern **a** und **b** wie in Abb. 6-2 gezeigt so einstellen, daß der Line Out Pegel -5,5 dBm, 315 Hz bzw. -6,1 dBm, 333 Hz beträgt.
 - c) Die REV PLAY-Betriebsart wählen und die Löschkopfhöhe durch Drehen der Muttern **a** und **b** nochmals einstellen, so daß die Pegeldifferenz (linker Kanal) zwischen den Betriebsarten FWD und REV innerhalb $\pm 0,5$ dBm liegt.
 - d) Die Einstellungen der Abschnitte a), b) und c) wiederholen.
 - e) Eine Spiegelcassette (AJ-751178) einlegen und die Betriebsart FWD PLAY wählen.
 - f) Die Höhe der Bandführung (A) durch Drehen der Mutter (A) und die Höhe des Löschkopfes (REV) durch Drehen der Mutter (B) so einstellen, daß das Band ohne Verformung an den Bandführungskanten vorbeiläuft.
 - g) Als nächstes die Betriebsart REV PLAY wählen und die Höhe der Bandführung (B) durch Drehen der Mutter (B) so einstellen, daß das Band ohne Verformung glatt über die angrenzenden Ränder beider Löschköpfe (FWD und REV) läuft.
 - h) Sicherstellen, daß der Line-Ausgangspegel (linker Kanal) -5,5 dBm und die Pegeldifferenz (linker Kanal) zwischen den Betriebsarten FWD und REV innerhalb von $\pm 0,5$ dBm liegt.
- 1) Sicherstellen, daß der Azimuth nach Abschnitt 6-2 korrekt ist.
 - 2) Eine 315 Hz (oder 333 Hz) Wiedergabepegel-Einstellcassette (AT-750773) in der FWD Wiedergabe-Betriebsart abspielen und den Wiedergabepegel-Einsteller (VR5 an der Vorverstärker-Leiterplatte) so einstellen, daß der LINE OUT-Pegel des linken Kanals -5,5 dBm beträgt.
Danach den Pegel des gleichen Kanals in der REV-Betriebsart überprüfen. Die Pegeldifferenz zwischen der FWD und der REV-Betriebsart sollte sich innerhalb $\pm 0,5$ dBm bewegen.
 - 3) Wenn im Abschnitt 2 die Differenz mehr als $\pm 0,5$ dBm beträgt, werden die Löschköpfe durch Drehen beider Löschkopfhöhen-Einstellschrauben **A** und **B** in der gleichen Richtung um $1/4$ Drehung ($\pm 0,1$ mm) so eingestellt, daß die Differenz innerhalb $\pm 0,5$ dBm liegt.
 - 4) Wenn durch Vornahme der obigen Einstellung die Differenz nicht korrigiert werden kann, ist eine Kopfhöhen-Einstellung erforderlich. Dies kann durch Auswechseln der Abstandshalter zur Einstellung der Kopfhöhe **i** und **j** vorgenommen werden (die Dicke dieser Abstandshalter beträgt **i** = 0,45 mm, **j** = 0,35 mm). Zum Austausch der Abstandshalter sind die Schrauben **e**, **f** und **g** lösen. Wenn der Pegel in der REV-Betriebsart niedriger ist, bedeutet dies, daß der Kopf zu hoch ist, in diesem Falle sind die Abstandshalter gegen dünnere auszutauschen. Wenn der Pegel in der REV-Betriebsart höher ist, sind die Abstandshalter gegen dickere auszutauschen.
Nach dem Austausch dieser Abstandshalter ist die gleiche Einstellung in Abschnitt 1) vorzunehmen und sicherzustellen, daß der Pegel von LINE OUT -5,5 dBm $\pm 0,5$ dBm beträgt.
Ferner zur Überprüfung eine 4-Spur-Kopfhöhen Einstellcassette (1 kHz/ 4 Spur, AT-750775) abspielen. Der LINE-Ausgangspegel beider Kanäle sollte mehr als -8 dBm betragen und die Pegeldifferenz zwischen den Betriebsarten FWD und REV sollte innerhalb ± 1 dBm liegen. Andernfalls ist die Feineinstellung in der gleichen Weise vorzunehmen wie im Abschnitt 3) und 4).
 - 5) Ist ein Austausch des Kopfes erforderlich, löst man nur die Schrauben **a** und **b** in Abb. 6-1.

6-2 KOMBIKOPF-AZIMUTH-EINSTELLUNG

(Siehe Abb. 6-2)

Eine 10kHz-Kopf Azimuth-Einstellcassette (AT-750778) wiedergeben und die Schrauben **c** (FWD-Richtung) und **d** (REV-Richtung) so einstellen, daß die Pegel beider Kanäle Maximum betragen.

(Hinweis: Die Schrauben nicht zu weit drehen, da andere (falsche) Maximalwerte weiter entfernt auf beiden Seiten der korrekten Position existieren.)

6-3 EINSTELLUNG DER KOPFHÖHE

(Siehe Abb. 6-1 und 6-2)

Diese Einstellung ist nicht erforderlich, da dieses Modell GX-R 88 mit einem rotierenden Kopfsystem (mit Aufnahme- und Wiedergabe-Kombikopf) ausgestattet ist. Die Überprüfung der korrekten Kopfhöhe ist jedoch erforderlich und wird wie folgt ausgeführt:

6-4 EINSTELLUNG DES KOPFBLOCK-VORSPRUNGS

Eine Tonkopfvorsprungs-Meßvorrichtung (AT-75i180) verwenden und die Wiedergabebetriebsart FWD oder REV wählen.

Die Schraube (h) lösen und das Kopfträgerchassis (k) so einstellen, daß das Meßgerät $3,1 \pm 0,15$ mm anzeigt. Nach der Einstellung Siegellack auf die Schraube (h) auftragen.

- HINWEIS:
1. Vor der Kopfeinstellung auf jeden Fall die Köpfe reinigen.
 2. Darauf achten, daß keine magnetischen Schraubenzieher oder sonstige magnetische Werkzeuge in der Umgebung der Köpfe verwendet werden.
 3. Vor und nach der Kopfeinstellung auf jeden Fall die Tonköpfe mit einer Entmagnetisierungsdrossel entmagnetisieren.

VII. ELEKTRISCHER ABGLEICH

7-1 ABGLEICH DER VORVERSTÄRKER-LEITERPLATTE

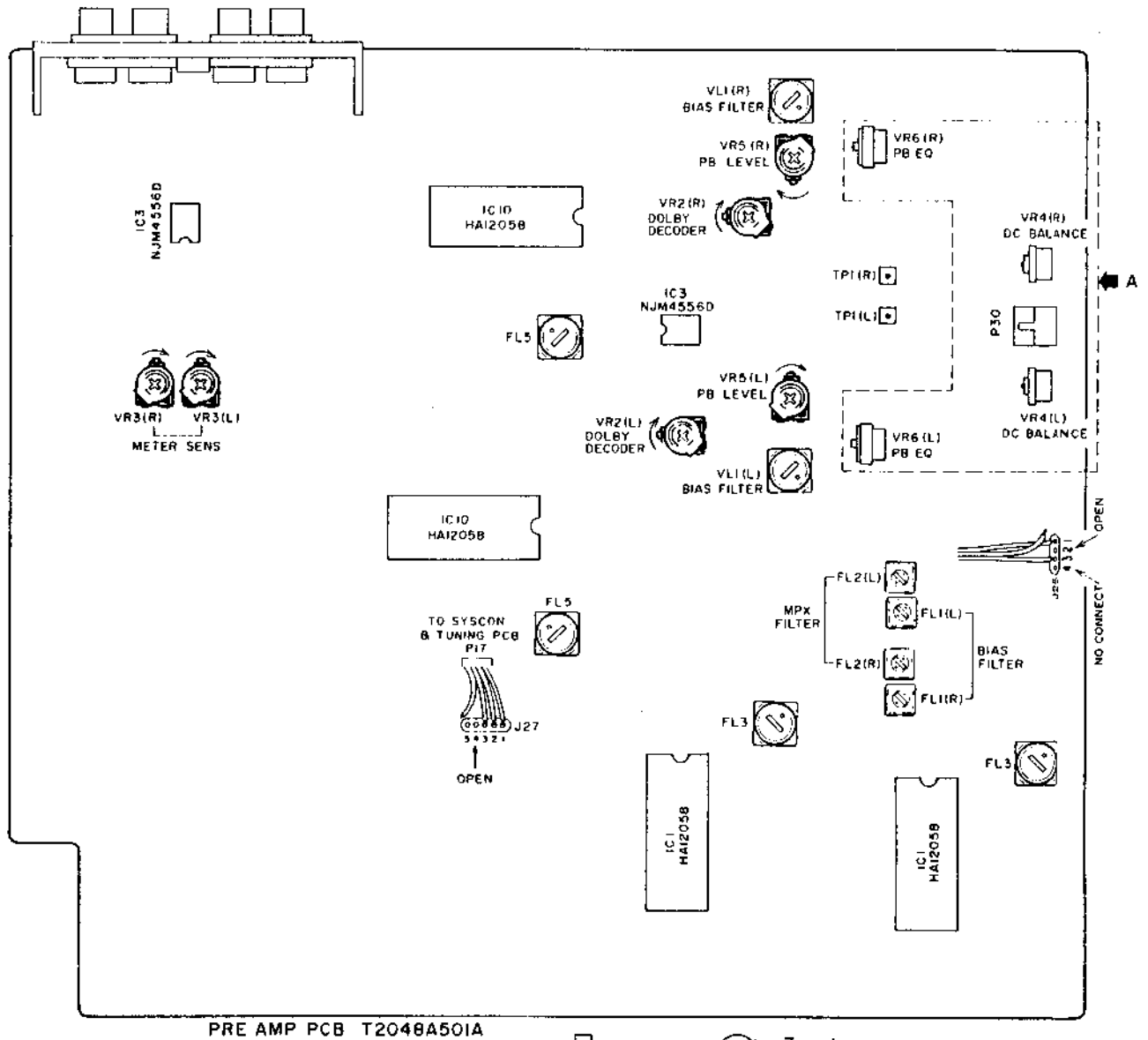

PRE AMP PCB T2048A501A

FRONT
 ↓
 ↻ : Zunahme

Abb. 7-1 Vorverstärker-Leiterplatte

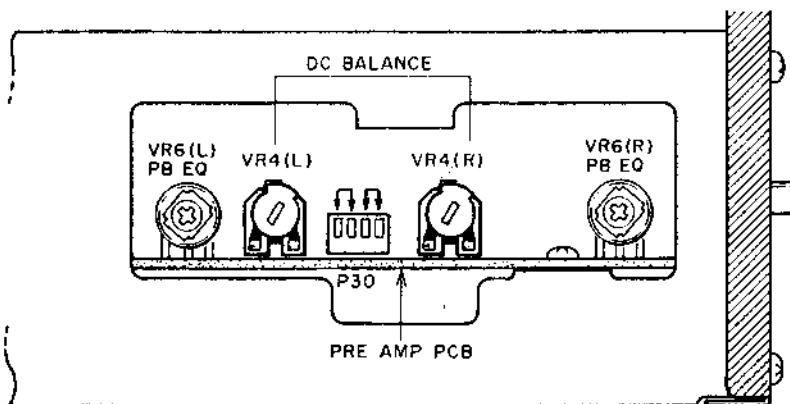

ANSICHT VON A

Abb. 7-2

VORVERSTÄRKER-ABGLEICH ÜBERSICHT

(für weitere Einzelheiten, Siehe 7-1-1 bis 7-1-3)

Schritt	Abgleich-gegenstand	Betriebs-art	Testcassette und angelegtes Signal	Abgleich-punkt	Ergebnis
1	DC Balance	STOP	Connect INPUT PIN of P30 with GND	VR4(L) VR4(R)	TP1(L) TP1(R) $0 \pm 100\text{mV D.C}$
2	P.B Level	FWD PLAY	333Hz 0 VU Tape (315Hz 0 VU Tape)	VR5(L) VR5(R)	LINE OUT $-6,1 \pm 0,1\text{dBm}$ ($-5,5 \pm 0,1\text{dBm}$)
		REV PLAY	333Hz 0 VU Tape (315Hz 0 VU Tape)	Überprüfung	
3	P.B EQ	FWD PLAY	10 kHz P.B EQ Tape	VR6(L) VR6(R)	LINE OUT $-20,5 \pm 0,2\text{dBm}$
		REV PLAY	10 kHz P.B EQ Tape	Überprüfung	$-20,5 \pm 2,0\text{dBm}$
4	ANZEIGE-Empfindlichkeit	TAPE MONITOR SOURCE	1 kHz LINE IN ($-5,2\text{ dBm LINE OUT}$)	VR3(L) VR3(R)	+1 VU Anzeige auf dem VU METER
5	Dolby Decoder	FWD PLAY	315Hz 0 VU Tape (333Hz 0 VU Tape)	VR2(L) VR2(R)	LINE OUT $-5,5 \pm 0,3\text{dBm}$ mit Dolby ($-6,1 \pm 0,3\text{dBm}$)
6	MPX Filter REC		19 kHz LINE IN	FL2(L) FL2(R)	LINE OUT MIN
7	BIAS Filter (Source)	REC/PLAY	Ohne Signal Reineisenband (REC VR MAX)	FL1(L) FL1(R)	LINE OUT MIN
		REC/PAUSE			
8	BIAS Filter (P.B)	REC/PLAY	Ohne Signal Reineisenband	VL1(L) VL1(R)	LINE OUT MIN

7-1-1 ABGLEICH DES WIEDERGABEENTZERRERVERSTÄRKERS (TUNING-LEITERPLATTE ist von der ANZEIGE-LEITERPLATTE abtrennbar)

1) DC Balance

- Den Anschlußstecker von P30 entfernen (WIEDERGABEKOPF-Anschlußstecker)
- Den INPUT SIGNAL PIN (Eingangssinalstift) von P30 Stift ①, ④ an Masse anschließen.
- VR4 so einstellen, daß die Spannung von TP1 $0 \pm 100\text{mV}$ -Gleichspannung beträgt.

2) Wiedergabepegel

- Mit FWD eine 333Hz-Wiedergabe-Einstellcassette (AT-750773) oder eine 315Hz-Wiedergabe-Einstellcassette (AT-750773) abspielen und VR5 einstellen, daß der LINE OUT-Pegel bei 333 Hz $-6,1 \pm 0,1\text{ dBm}$ bzw. bei 315 Hz $-5,5 \pm 0,1\text{ dBm}$ beträgt.

- Mit REV Wiedergabe eine 333 Hz oder 315Hz-Wiedergabepegel-Einstellcassette abspielen und sicherstellen, daß der LINE OUT-Pegel $-6,1 \pm 0,6\text{ dBm}$ (333 Hz) bzw. $-5,5 \pm 0,6\text{ dBm}$ (315 Hz) beträgt.

3) Wiedergabeentzerrung

- Eine 10kHz-Wiedergabeentzerrungs-Einstellcassette (AT-750778) im FWD-Richtung abspielen und VR6 so einstellen, daß der LINE OUT-Pegel $-20,5 \pm 0,2\text{ dBm}$ beträgt.
- Eine 10kHz-Wiedergabeentzerrungs-Einstellcassette in REV-Richtung abspielen und sicherstellen, daß der LINE OUT-Pegel $-20,5 \pm 2,0\text{ dBm}$ beträgt.

7-1-2 ABGLEICH DER ANZEIGEEMPFINDLICHKEIT

- a. Den Monitorschalter auf SOURCE und den Anzeigeumschalter auf VU ein 1 kHz-Signal an LINE IN und ein 1 kHz-Signal $-5,2$ dBm an LINE OUT $-5,2$ dBm an LINE OUT anlegen.
- b. VR3 so abgleichen, daß +1 VU erreicht wird.

7-1-3 DOLBY-ABGLEICH

- 1) Dolby-Decoder-Abgleich
 - a. Eine 315Hz-Wiedergabepegel-Einstellcassette (AT-750773) abspielen.
 - b. VR2 so abgleichen, daß der LINE OUT-Pegel bei Dolby EIN $-5,5 \pm 0,3$ dBm beträgt. (Bei Verwendung der 333Hz-Wiedergabepegel-Einstellcassette beträgt der LINE OUT-Pegel $-6,1 \pm 0,3$ dBm.
- 2) MPX-Filter-Abgleich
 - a. Eine Leercassette einlegen und die REC/PLAY-Betriebsart einschalten.
 - b. Mit dem MPX-Filter-Schalter in der AUS-Stellung ein 19kHz-Signal über LINE IN anlegen.
 - c. FL2 so abgleichen, daß der LINE OUT-Pegel Minimum beträgt, wenn der MPX-Filter-Schalter eingeschaltet wird.
- 3) BIAS-Filterabgleich
 - a. Eine Reineisenband-Cassette einlegen und die REC/PLAY-Betriebsart einschalten (bzw. REC/PLAY \rightarrow REC/PAUSE).
 - b. FL1 so abgleichen, daß der LINE OUT-Pegel Minimum beträgt, wenn die Aussteuerung auf MAX eingestellt ist und der Monitorschalter auf SOURCE steht.
 - c. Eine Reineisenband-Cassette einlegen und die REC PLAY-Betriebsart einschalten.
 - d. VL1 so abgleichen, daß der LINE OUT-Pegel Minimum beträgt, wenn der Monitorschalter auf TAPE gestellt wird.

7-2 EINMESS-ABGLEICHPUNKTE



Abb. 7-3 Sys-con und Einmeß-Leiterplatte

EINMESS-ABGLEICH-TABELLE

(Für weitere Einzelheiten, siehe 7-2-1 bis 7-2-7)

Alle, die Aufnahme betreffenden Abgleicharbeiten, müssen in dieser REF-Betriebsart ausgeführt werden.

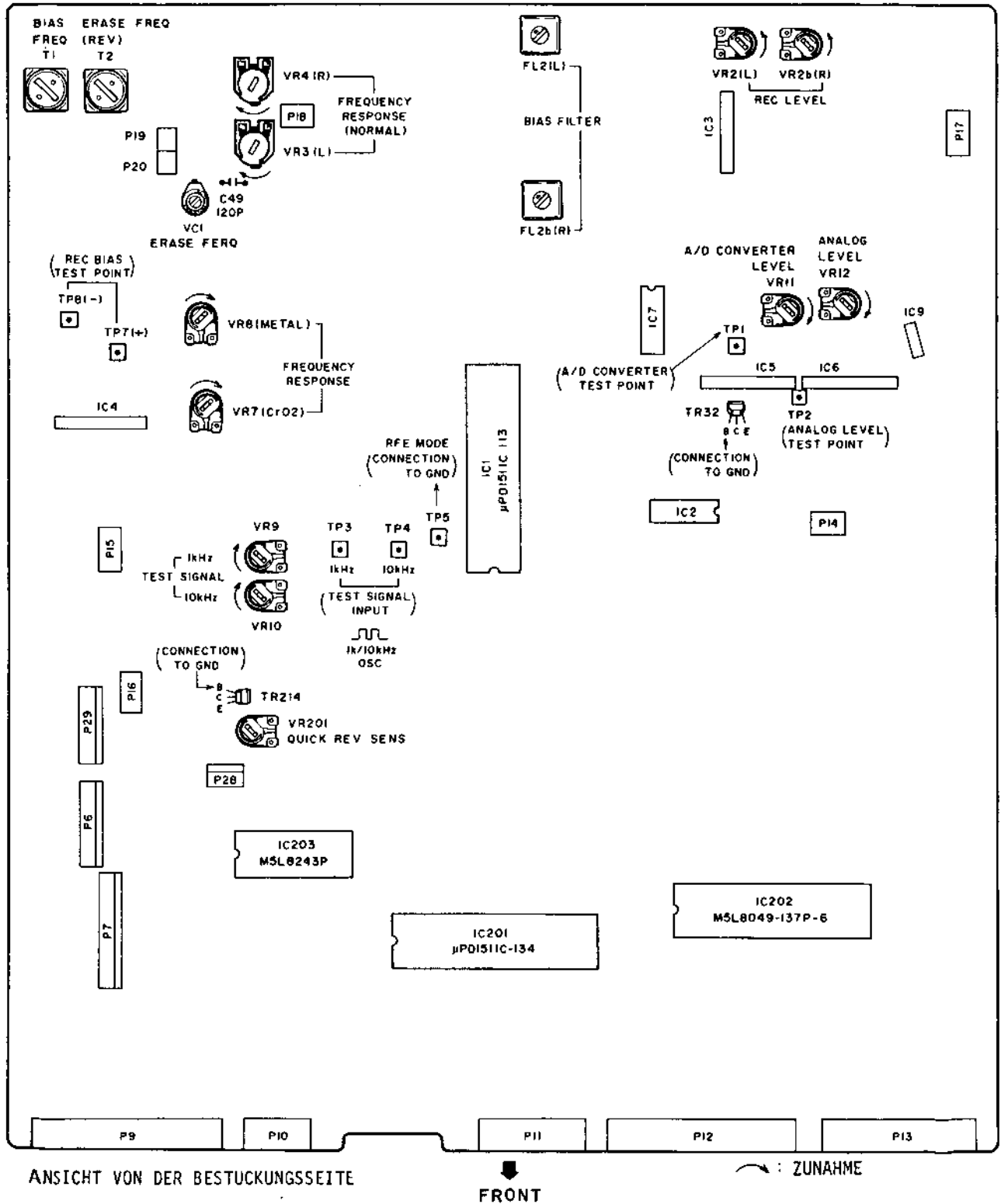
Die REF-Betriebsart erhält man, indem TP5 auf der Einmeß-Leiterplatte innerhalb 3 Sekunden nach Einschalten des Gerätes geerdet wird. (Siehe Hinweis 3)

Schritt	Abgleichgegenstand	Betriebsart	Testcassette und angelegtes Signal	Abgleichpunkt	Ergebnis	Bemerkungen
1	Erase OSC	REV REC REC PAUSE	METAL TAPE	T2	100±0,2kHz	Anschluß des Zählers an P19
		FWD REC REC PAUSE	METAL TAPE	VC1	100±1kHz	Anschluß des Zählers an P20
2	Rec Bias OSC	FWD REC REC PAUSE	METAL TAPE	T1	MINIMUM DC VOLTAGE	Zwischen TP7 (+) und TP8(-)
3	Freq Response (Norm)	FWD REC/PB	NORMAL TAPE 1kHz, 10kHz -25,5dBm	VR4(L) VR3(R)	1kHz to 10 kHz FLAT	
		REV REC/PB	Gleich wie FWD			Überprüfung
	(CrO ₂)	FWD REC/PB	CrO ₂ TAPE 1kHz, 10kHz -25,5dBm	VR5	1kHz to 10 kHz FLAT	
		REV REC/PB	Gleich wie FWD			Überprüfung
	(Metal)	FWD REC/PB	METAL TAPE 1kHz, 10kHz -25,5dBm	VR6	1kHz to 10 kHz FLAT	
		REV REC/PB	Gleich wie FWD			Überprüfung
4	Recording Level	FWD REC/PB	NORMAL TAPE 1kHz -5,5dBm	VR1(L) VR2(R)	-5,5±0,2dBm	
		REV REC/PB	Gleich wie FWD		FWD RESULT ±0,5dBm	
5	A/D Converter	FWD REC PAUS		VR11	3,0±0,05 V DC	Anschluß des Digitalvoltmeters an TP1
6	Analog Level		10kHz -25,5±0,2dBm to J27- 4	VR12	3,0±0,05 V DC	J27- 4 ablöten, B von TR32 erden.
7	Test Signal (1kHz, 10kHz)	TAPE MONITOR SOURCE	SQUARE WAVE 1kHz, 1 to 2V to TP3	VR9	-26,5±0,2 dBm	LINE OUT
			SQUARE WAVE 10kHz, 1 to 2V to TP4	VR10	-26,5±0,2 dBm	LINE OUT
2 bis 3 mal wiederholen, so daß in Schritt 7 nahezu gleiches Resultat erreicht wird.						

HINWEIS:

1. Zur Messung folgende Kassettentypen verwenden:
Normalband: Maxell UD C-60
CrO₂-Band: TDK SA C-60
Reineisenband : TDK MA C-60
2. a. Für den Vorverstärker-Abgleich, siehe Abb. 7-1 und 7-2.
b. Für den Einmeß-Abgleich, siehe Abb. 7-3.

7-2-1 LÖSCH-OSC-ABGLEICH

- a. Ein Reineisenband einlegen und die REV REC/PLAY-Betriebsart einschalten.
- b. Den Frequenzzähler an T19 (Einmeß-Leiterplatte) anschließen und T2 so abgleichen, daß die Frequenz $100 \pm 0,2$ kHz beträgt.
- c. Den Frequenzzähler an P20 (Einmeß-Leiterplatte) anschließen und VC1 so abgleichen, daß die Frequenz 100 ± 1 kHz beträgt. Wird dieses Ergebnis nicht erreicht, muß C49 (120P) ausgelötet und VC1 nochmals abgeglichen werden, um diesen Wert zu erhalten.

7-2-2 ABGLEICH DER VORMAGNETISIERUNG

- a. Ein Gleichspannungsvoltmeter an TP7(+) und TP8(-) anschließen und T1 auf Spannungsminimum abgleichen.

7-2-3 EINSTELLUNG DES FREQUENZGANGS

- a. Eine FWD-Aufnahme und Wiedergabe mit 1 kHz/10 kHz, -25,5 dBm auf Normalband machen. VR4 (linker Kanal) und VR3 (rechter Kanal) so einstellen, daß gleicher Pegel bei beiden Frequenzen erzielt wird. Der Unterschied zwischen beiden Kanälen sollte höchstens 0,5 dBm betragen.
- b. Unter gleichen Bedingungen wie in a. erläutert eine FWD-Aufnahme und Wiedergabe auf CrO₂ Band machen und mit VR5 auf gleichen Pegel einstellen.
- c. Reineisenband wird unter den gleichen Bedingungen wie in a. beschrieben mit VR6 eingestellt.
- d. Der REF-Betrieb ist mit allen 3 Bandarten zu überprüfen.

7-2-4 AUFNAHMEPEGEL-ABGLEICH

- a. Eine FWD-Aufnahme und Wiedergabe mit 1 kHz, -5,5 dBm machen und VR2 so abgleichen, daß die Differenz zwischen Aufnahme- und Wiedergabepiegel $0 \pm 0,2$ dBm beträgt.
- b. Überprüfen, daß die Differenz zwischen FWD und REV innerhalb 0,5 dBm liegt.

3. Besondere Hinweise bei der REF-Betriebsart

- a. Die REF-Betriebsart kann nur durch Ausschalten des Gerätes aufgehoben werden.
- b. In der REC-Betriebsart leuchtet nur die REC-Anzeige (nicht die TUNING-Anzeige) auf.
- c. Das Eingangssignal wird in der REF-Betriebsart stummgeschaltet, falls J25 Stift ② nicht abgetrennt wird.

7-2-5 ABGLEICH DES A/D-UMSETZERS

- a. Die REC/PAUSE-Betriebsart einschalten.
- b. VR11 so abgleichen, daß die Spannung am TP1 nach Masse $3 \pm 0,05$ V Gleichspannung beträgt.

7-2-6 ABGLEICH DES ANALOGPEGELS

- a. Den an J27 ④ der Vorverstärker-Leiterplatte angelöteten Draht ablöten. (Siehe Abb. 7-1) (Der Draht ist Rc PB out).
- b. Die Basis von TR32, die Rückseite von R137 oder die linke Seite von R138 mit Masse verbinden.
- c. 10 kHz, $-25,5 \pm 0,2$ dBm an den PB out (rechter Kanal) Anschluß ④ anlegen. Die Eingangsspannung zwischen den Anschlüssen nach Masse messen. ($-25 \pm 0,2$ dBm)
- d. VR12 so abgleichen, daß die Spannung am TP2 gegen Masse $3 \pm 0,05$ V Gleichspannung beträgt.

7-2-7 ABGLEICH TESTSIGNALPEGEL

- a. Den an J25 ② der Vorverstärker-Leiterplatte angelöteten Draht, ablöten. (Siehe Abb. 7-1)
- b. Monitor-Schalter auf SOURCE stellen.
- c. Ein 1 kHz Rechtecksignal von 1 bis 2 V an TP3 anlegen. Der Eingangsspannungspegel ist mit dem Oszilloskop zu messen.
- d. VR9 so abgleichen, daß der LINE OUT-Pegel $-26,5 \pm 0,2$ dBm beträgt.
- e. Danach das Rechtecksignal von TP3 an TP4 anschließen.
- f. VR10 so abgleichen, daß der LINE OUT-Pegel $-26,5 \pm 0,2$ dBm beträgt.
- g. Diesen Einstellvorgang 2 bis 3 mal wiederholen, bis gleicher Pegel erreicht wird.

7-3 EINSTELLUNG DER
QUICK-REVERSE-EMPFINDLICHKEIT
(Siehe Abb. 7-4)

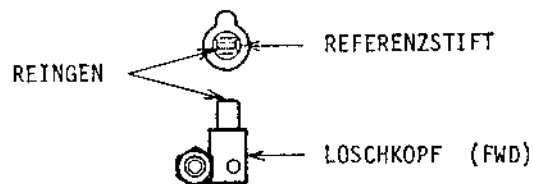

Abb. 7-4

- a) Durch Entnahme des Bandes aus dem Cassettengehäuse, eine bandlose Cassette herstellen.
- b) Das Digitalvoltmeter zwischen der Basis von TR214 und Masse anschließen.
- c) Unter Verwendung der bandlosen Cassette VR201 (an der SYS-CON LEITERPLATTE, siehe Abb. 7-3) so einstellen, daß das Digitalvoltmeter in der FWD Wiedergabe $4,30 \pm 0,05V$ -Gleichspannung anzeigt.

HINWEIS: Vor dieser Einstellung den Referenzstift und den Löschkopf (FWD-Seite) reinigen. (Siehe Abb. 7-4)