

AKAI SERVICE MANUAL

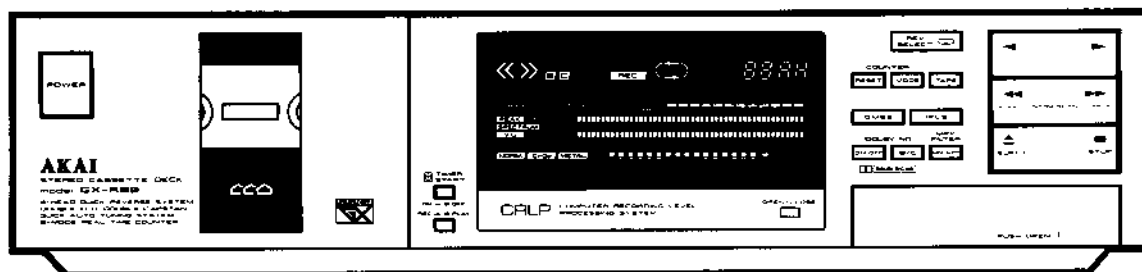

STEREO CASSETTE DECK

MODEL **GX-R99**

ABBREVIATIONS FOR SERVICE MANUAL MODEL GX-R99

Abbreviation	Explanation	Abbreviation	Explanation
AC	Alternating Current	MEMO	MEMOry
A/D	Analog/Digital	MICOM	MIcroCOMputer
AF	Auto Fader	MIN	MINute
AM	Auto Monitor	MML	Maximum Modulation Level
AMP	AMP lifier	MOL	Maximum Output Level
AR	Anti Recording	MPX	Multi PleX
AT BIAS	Auto Tuning BIAS	NC	Not Connected (No Connection)
ATT	ATTenuator	NFB	Negative Feed Back
BAL	BALance	NORM	NORMAl
BEF	Band Elimination Filter	NR	Noise Reduction
BSS	Blank Search System	OSC	OSCillator (OSCillation)
CH	CHannel	P	Pulse
CN	Cam Normal	P.B.	Play Back
COMP	COMParator	QMSS	Quick Memory Search System
CR	Cam Reverse	R	Right
CRLP	Computer Recording Level Processing	REC	RECord (RECording)
CS	Cam Stop	REV	REVERSE
D	Down	ROT	ROTation
D/A	Digital/Analog	REW	REWind
DC	Direct Current	SEC	SECond
DET	DETECTOR	SELE	SELEctor
DISCRI	DISCRIminator	SENS	SENSitivity
EQ	EQualizer	SEPP	Single Ended Push Pull
FF	Fast Forward	SIG	SIGnal
FLD	FLuorescent Display	SPECT	SPECTrum
FREQ	FREQUency	STD	STANDARD
FWD	ForWard	SW	SWitch
GND	GrouND	SYSCON	SYStem CONtrol
H	High	TP	Test Point
HPF	High Pass Filter	U	Up
IND	INDicator	VCA	Voltage Control Attenuator
IPLS	Instant Program Location System	VOL	VOLume
L	Low	VOLT	VOLTage
LED	Light Emitting Diode	VR	Variable Resistor
M	Motor	X'TAL	crystAL

Da dieses Wartungshandbuch bereits auf Englisch veröffentlicht ist und Einstell- und Zeichnungshinweise auf Deutsch enthält, empfiehlt es sich, diese Ausgabe des Handbuchs zusammen mit der bereits veröffentlichten englischen Ausgabe und den Stromlaufplänen zu verwenden.

STEREOCASSETTENDECK

MODEL GX-R99

I. TECHNISCHE DATEN

Spursystem	Kompaktcassette, Stereo	Fremdspannungsabstand ...	Reineisen: 60 dB
Motoren	FG-Direktantrieb-Servomotor für Tonrollentrieb x 2 Gleichstrommotor für Spulentrieb x 1 Gleichstrommotor für Antrieb des Mechanismus x 1 Gleichstrommotor für Antrieb der Aufnahme-Bedienungstafel x 1		Dolby Typ C EIN: Verbessert bis zu 15 dB bei 500 Hz, 20 dB bei 1 kHz bis 10 kHz Dolby Typ B EIN: Verbessert bis zu 5 dB bei 1 kHz, 10 dB oberhalb 1 kHz
Tonköpfe	Super-GX-Kopf für Aufnahme x 1 Super-GX-Kopf für Wiedergabe x 1 Löschkopf x 2	Eingang	LINE IN: 70mV/47kOhm
Gleichaufschwankungen ..	0,028% (WRMS), 0,08% WTD (DIN)	Ausgang	LINE OUT: 410mV/250 Ohm PHONES: 1,3mW/8 Ohm
Vor-/Rückspulzeit	90 Sek. (mit C-60 Cassette)	Stromversorgung	120V, 60 Hz für Kanada & USA 220V, 50 Hz für Europa außer GB 240V, 50 Hz für GB & Australien
Verzerrung	0,5% (Reineisen)	Abmessungen	440(B) x 105(H) x 372(T) mm
Frequenzgang	Reineisen: 20 Hz bis 21 000 Hz \pm 3 dB Chrom: 20 Hz bis 19 000 Hz \pm 3 dB Normal: 20 Hz bis 18 000 Hz \pm 3 dB	Gewicht	8,7 kg
		* Änderungen der technischen Daten und des Designs zum Zwecke der Verbesserung vorbehalten.	

II. SICHERHEITSHINWEISE

SICHERHEITSKONTROLLE NACH WARTUNGSARBEITEN

Sicherstellen, daß der vorgegebene Isolierwiderstand zwischen den Stifen des Netzkabelsteckers und den äußeren, freiliegenden Gehäuseteilen mehr als 10 MOhm beträgt; hingegen soll bei Geräten mit Klemmen für Außenantennen (Tuner, Receiver usw.), die für [C] oder [A] vorgesehen sind, der vorgegebene Isolierwiderstand mehr als 2,2 MOhm (Erdungsklemmen, Mikrofonbuchsen, Kopfhörerbuchsen, (Line-in-out-Buchsen usw.) betragen.

BEI WARTUNGSARBEITEN ZU BEACHTENDE VORSICHTSMASSNAHMEN

1. Bei mit dem Symbol markierten Teilen sind die Sicherheitsvorschriften besonders sorgfältig zu beachten.
Den Austausch nur gegen Teile mit vorgeschriebener Teilenummer vornehmen.
2. Abgesehen von Sicherheitsmarkierungen werden sonstige Teile und Einheiten spezifiziert im Hinblick auf Übereinstimmung mit Regelungen, wie z.B. für Nebenausstrahlung, auch solche Teile dürfen nur gegen vorgeschriebene Austauschteile ausgetauscht werden.
Beispiele: Hf-Umsetzer, Tunereinheiten, Antennenwahlschalter, Hf-Kabel, rausch unterdrückende Kondensatoren, rauschunterdrückende Filter usw.
3. Die vorgeschriebene interne Verdrahtung verwenden. Insbesondere auf Folgendes achten:
 - 1) mit PVC-Kabelschutzrohr versehene Leitungen
 - 2) doppelt isolierte Leitungen
 - 3) Hochspannungsleitungen
4. Für Teile, die gefährlich hohe Spannungen führen, nur die vorgeschriebenen Isoliermaterialien verwenden. Dabei ist besonders zu achten auf:
 - 1) Isolierband
 - 2) PVC-Kabelschutzrohr
 - 3) Abstandhalter (Isoliersperren)
 - 4) Isolierfolien für Transistoren
 - 5) Plastikschrauben zur Befestigung von Mikroschaltern (insbesondere bei Plattenspielern)
5. Beim Austauschen von Komponenten auf der Netzspannung-Primärseite (Transformatoren, Netzkabel, rauschunterdrückende Kondensatoren usw.) sind die Kabelenden vor dem Verlöten vorschriftsmäßig um die Klemmen zu wickeln.

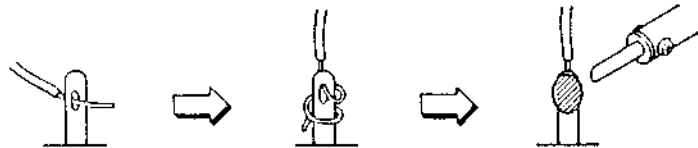

6. Darauf achten, daß Leitungen nicht in Kontakt mit wärmeproduzierenden Teilen geräte (z.B. Kühlkörpern, Metalloxidfolien-Widerständen, unterbrechbaren Widerstände usw.)
7. Sicherstellen, daß beim Austausch von Leitungen diese nicht in Kontakt mit scharfen Kanten oder spitzen Teilen geräten.
8. Desgleichen die Bereiche in der Umgebung von Stellen, an denen repariert wurde, überprüfen.
9. Darauf achten, daß keine Fremdkörper (Schrauben, Lot usw.) innerhalb des Gerätes verbleiben.

III. SPANNUNGSMUMSTELLUNG

3-1 SPANNUNGSMUMSTELLUNG

Modelle für Kanada, USA, Europa, Großbritannien und Australien sind nicht mit dieser Einrichtung ausgestattet. Jedes Gerät wird im Werk dem Bestimmungsort entsprechend eingestellt. Manche Geräte können aber, falls notwendig, auf 110V, 120V, 220V oder 240V umgestellt werden. Falls die Spannung des Geräts umgeschaltet werden kann:

1. Netzkabel herausziehen.
2. Den Spannungswähler (VOLTAGE SELECTOR) auf der Geräterückseite mit einem Schraubenzieher so drehen, daß die korrekte Netzspannung angezeigt wird.

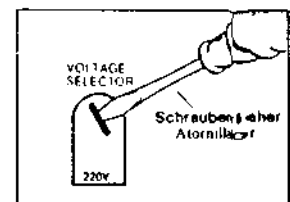

5-3 EINSTELLUNG DES REGLERS (VR901) UND DES KURVENRADES
(Siehe Abb. 5-3)



Abb. 5-3

- 1) Einstellung des Positionsreglers (Potentio-Antriebszahnrad). Das rechte Ende von Marke (A), wie in der Zeichnung gezeigt, mit der Mitte von Marke (B) ausrichten (Abb. 5-3 ①).
- 2) Auf die mit "X" markierten Teile Molybdän-Schmiermittel auftragen. (Abb. 5-3 ②)
- 3) Das Kurvenrad auf dem Capstanhalter (A) anbringen. Wenn das Kurvenrad korrekt angebracht ist, stimmt die Mitte von Marke (D) mit dem rechten Ende von Marke (C) überein. (Abb. 5-3 ③)
- 4) Den Federring in die Rille des Capstanhalters einsetzen.
- 5) Das Kurvenrad (R) auf dem Capstanhalter (B) anbringen. Wenn das Kurvenrad (R) korrekt positioniert ist, stimmt die Mitte von Marke (E) mit der Mitte von Marke (F) überein. (Abb. 5-3 ④)

V. MECHANISCHE EINSTELLUNG

5-1 MESSUNG DES ANDRUCKROLLENDRUCKS (Siehe Abb. 5-1)

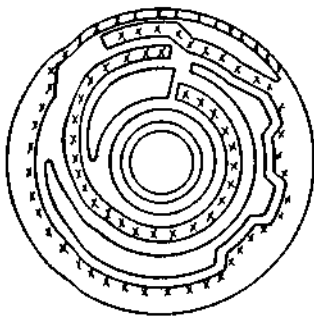
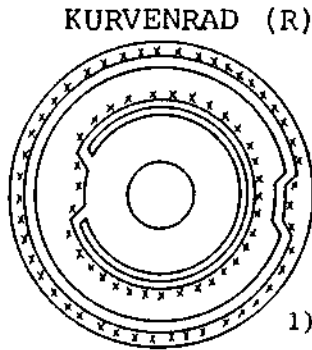
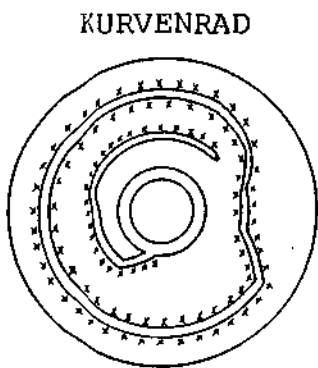
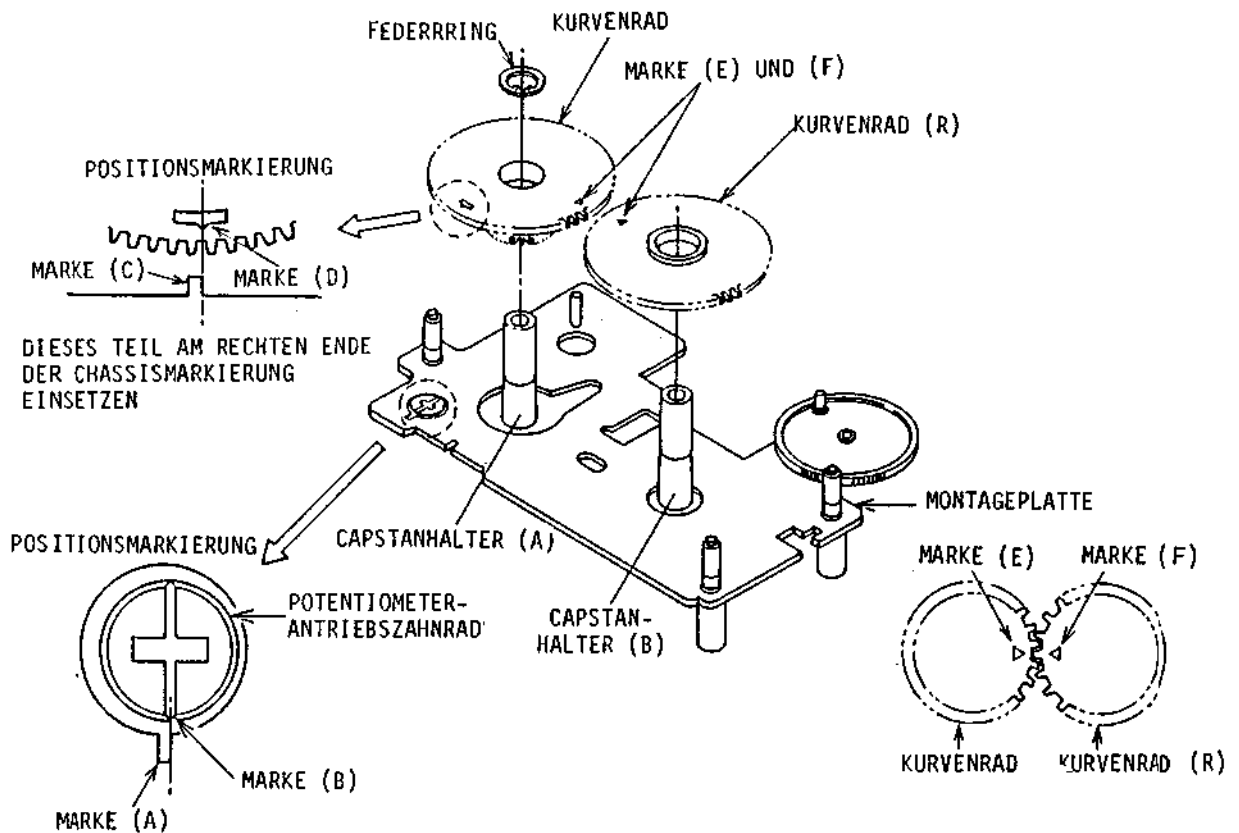

Abb. 5-1

Das Gerät auf FWD PLAY schalten. Die Andruckrollenwelle mit der Federwaage so herunterdrücken, daß ein Abstand von 1-2 mm zwischen Andruckrolle und Capstan entsteht. Anschließend den Druck abschwächen, bis sich die Andruckrolle wieder zu drehen beginnt. In diesem Zustand den Wert ablesen. Der vorgeschriebene Andruck beträgt.

RECHTE SEITE: 450 ± 80 g
 LINKE SEITE: 400 ± 80 g

Sicherstellen, daß der Andruckrollendruck bei REV PLAY

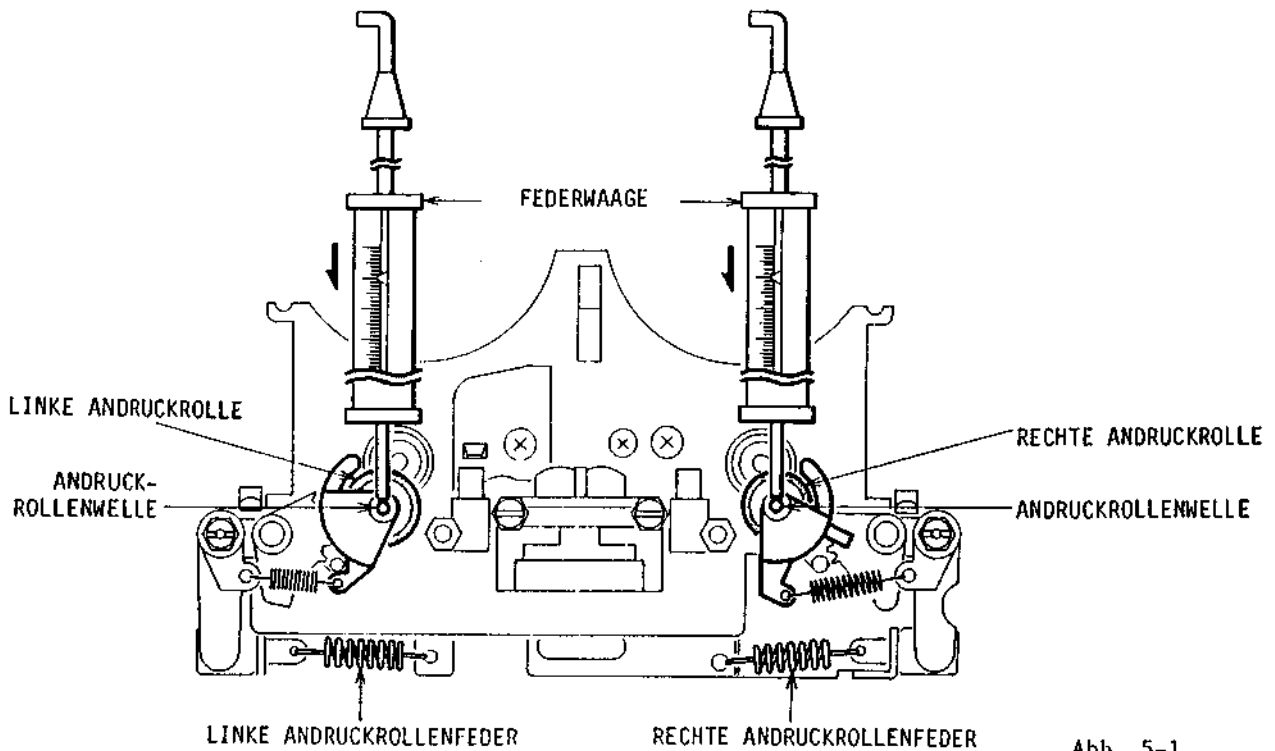
RECHTE SEITE: 400 ± 80 g
 LINKE SEITE: 450 ± 80 g
 beträgt. Falls dieser Wert nicht erreicht wird, ist die Andruckrollenfeder auszutauschen.

5-2 WICKEL-DREHMOMENT IN ALLEN BETRIEBSARTEN (Siehe Abb. 5-2)



Abb. 5-2

Ein Cassetten-Drehmoment-Meßgerät (AJ-751179) einlegen und die Messung in allen Betriebsarten durchführen. Die Messung des schnellen Vor- und Rücklaufs an Bandende d.h. nach Stoppen des Bandlaufs ausführen.

Vorlauf- oder Reverse-Betriebsart

Aufwickeldrehmoment: $40 \begin{matrix} +15 \\ -10 \end{matrix}$ g-cm

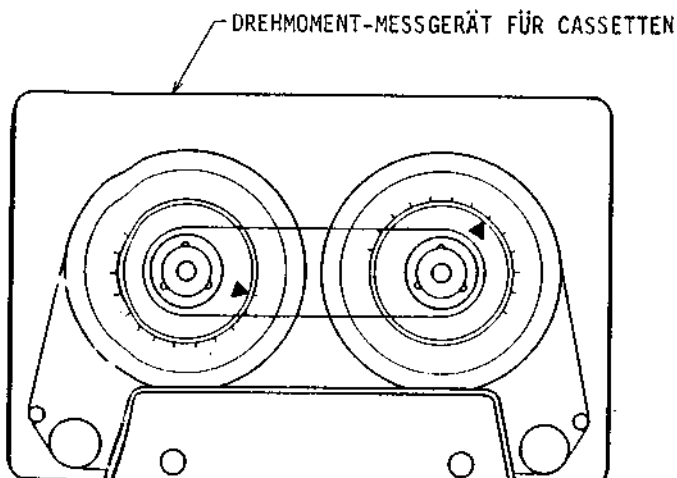
Abwickelzug-Drehmoment: 17 ± 3 g-cm

Betriebsart Schneller Vor- und Rücklauf

Aufwickeldrehmoment: $100 \begin{matrix} +50 \\ -30 \end{matrix}$ g-cm

5-4 ABGLEICH DER VORGEGEBENEN POTENTIOMETER-SPANNUNG
(Siehe Abb. 5-4 bis 5-8)



Abb. 5-4



Abb. 5-5

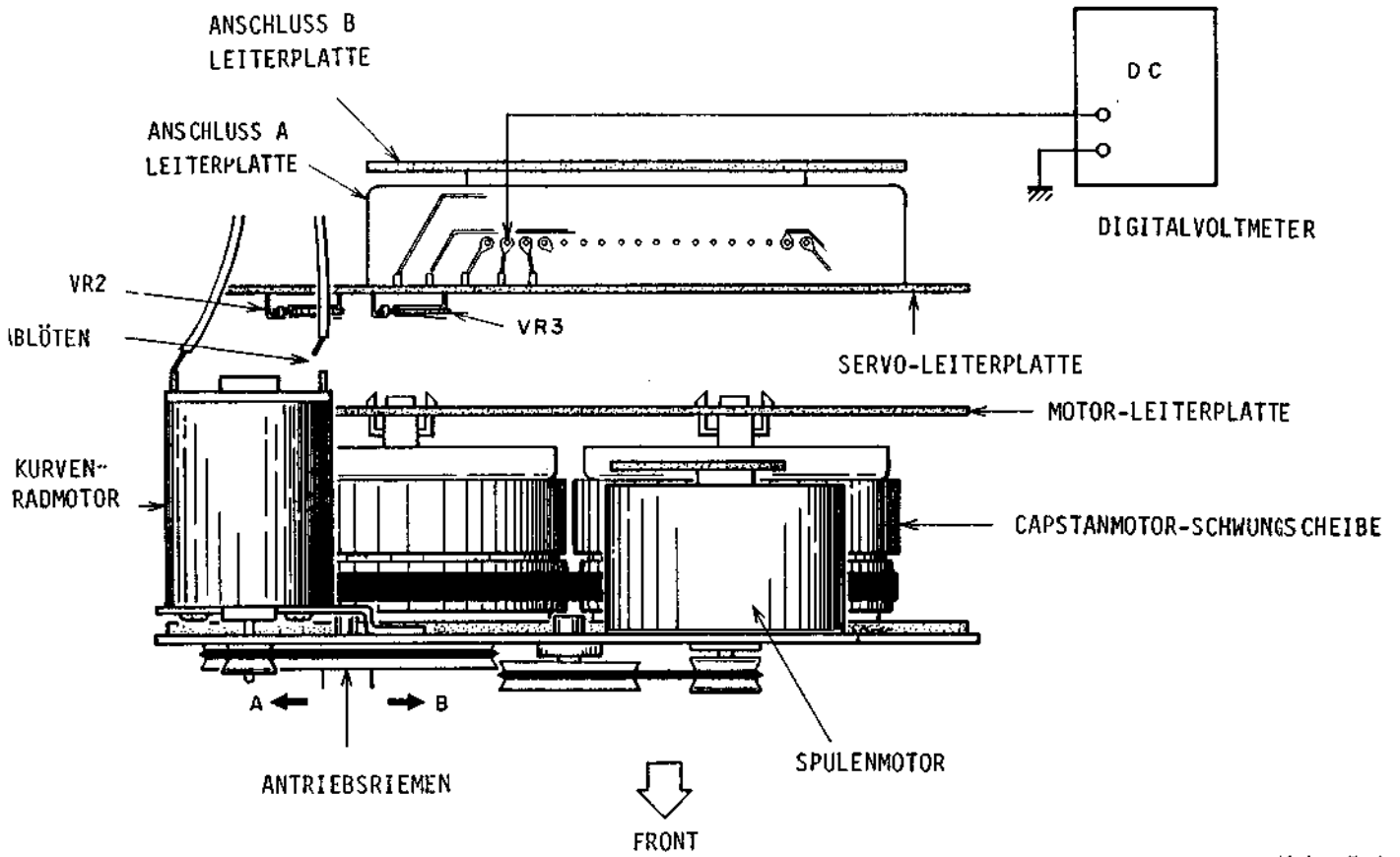

Abb. 5-6

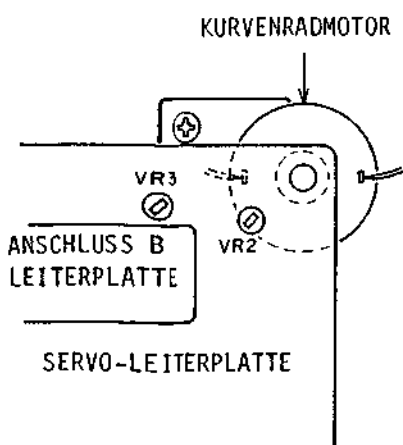

Abb. 5-7

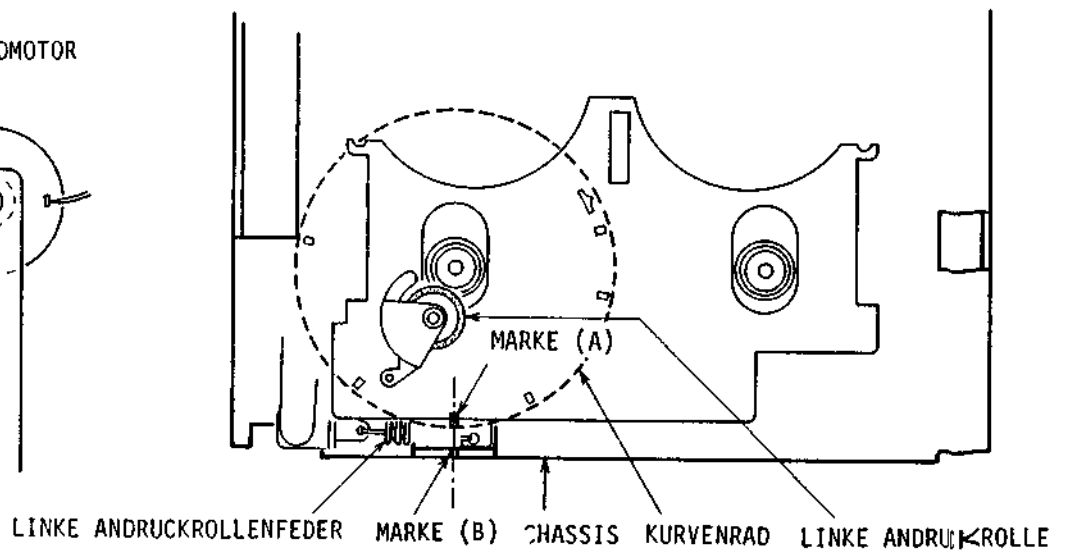

Abb. 5-8

- 1) ABGLEICH DER NIEDERSPANNUNG (Siehe Abb. 5-4 und Abb. 5-5)
 - a. Bei ausgeschalteter Stromversorgung das Anschlußkabel vom Kurvenradmotor ablösen und den Antriebsriemen mit dem Finger so weit wie möglich in Richtung A drehen.
 - b. Das Digitalvoltmeter wie in Abb. 5-4 gezeigt anschließen.
 - c. Bei eingeschaltetem Gerät VR3 so abgleichen, daß die abgelesene Spannung $1,255 \pm 0,05$ V beträgt.
- 2) ABGLEICH DER HÖCHSTSPANNUNG (Siehe Abb. 5-4 und Abb. 5-5)
 - a. Bei abgeschaltetem Gerät den Antriebsriemen mit den Fingern bis zum Anschlag in Richtung B drehen.
 - b. Bei eingeschaltetem Gerät VR2 so einstellen, daß die abgelesene Spannung $9,22 \pm 0,01$ V beträgt.
- 3) Die Abschnitte 1) und 2) wiederholen.
- 4) a. Bei ausgeschalteter Stromversorgung das Anschlußkabel des Motors anschließen.
 b. Das Digitalvoltmeter abtrennen.
 c. Die Schrauben a) bis f) in Abb. 5-6 entfernen und den gesamten Mechanikblock leicht herausziehen.
- 5) a. Das Gerät einschalten.
 b. VR2 etwas verstellen, so daß in der STOP-Betriebsart die Mitte der Marke (A) mit der Mitte der Marke (B) übereinstimmt (die Spannung in der STOP-Betriebsart beträgt ca. 7,35 V wenn die Versorgungsspannung an ① in Abb. 5-4 9,75 V beträgt).
 c. Den Cassettendeckel entfernen und mit dem AUTO SYSTEM-Schalter die IPLS-Betriebsart einschalten.
 d. Sicherstellen, daß bei abwechselndem Drücken der Vorlauf- und Rücklauf-tasten der Tonkopf nicht auf- und abbewegt wird.
 e. Mit den Fingern die Spule in der STOP-Betriebsart drehen, um sicherzustellen, daß die Bremse zufriedenstellend arbeitet.
 Wenn die Bremse normal funktioniert, dreht sich die Aufwickelspule nicht im Uhrzeigersinn und die Abwickelspule nicht gegen den Uhrzeigersinn.

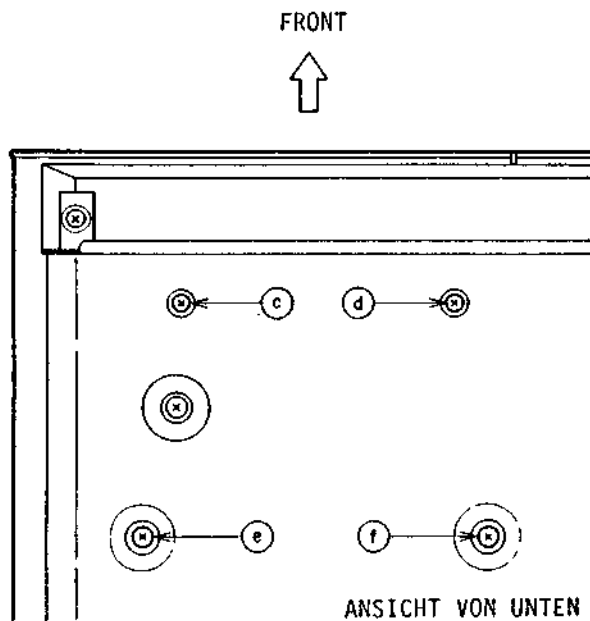
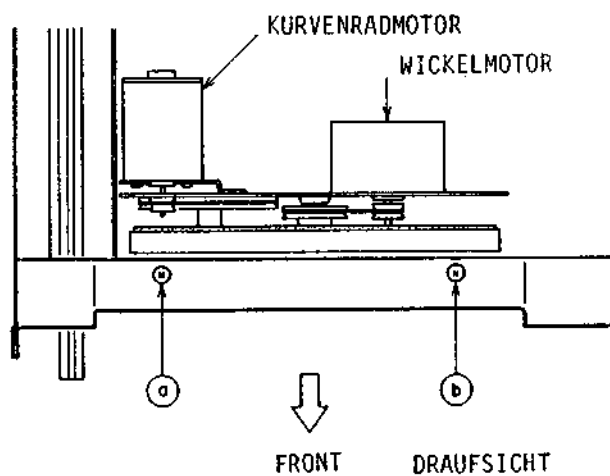
5-5 EINSTELLUNG DER BANDGESCHWINDIGKEIT (Siehe Abb. 5-9)

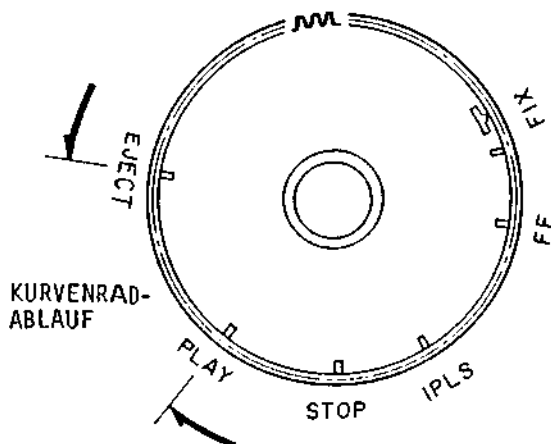

Abb. 5-9

Einen Frequenzzähler an die Line-Ausgang anschließen. Eine bespielte 1000Hz-Test-cassette (AT-750774) abspielen und den Bandgeschwindigkeits-Einstellregler (SERVO LEITERPLATTE) so einstellen, daß eine Frequenz von 995 bis 1005 Hz erreicht wird.

VI. TONKOPFEINSTELLUNG

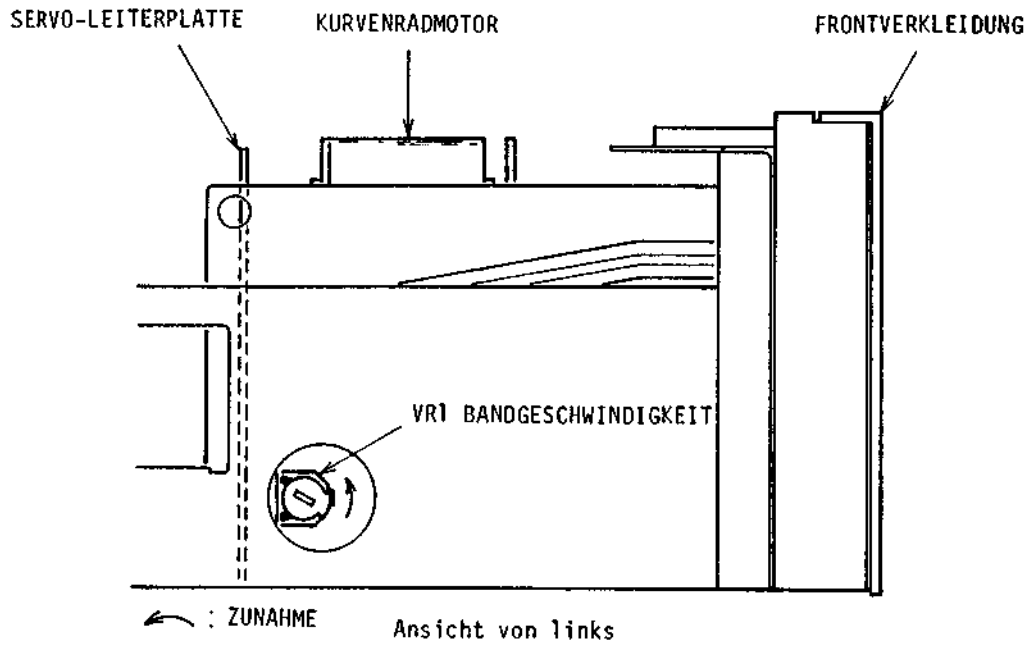

Abb. 6-1



ABSTANDSHALTER ZÜR
KOPFHÖHEN-EINSTELLUNG
AN DEN PUNKTEN
i a j

Abb. 6-2

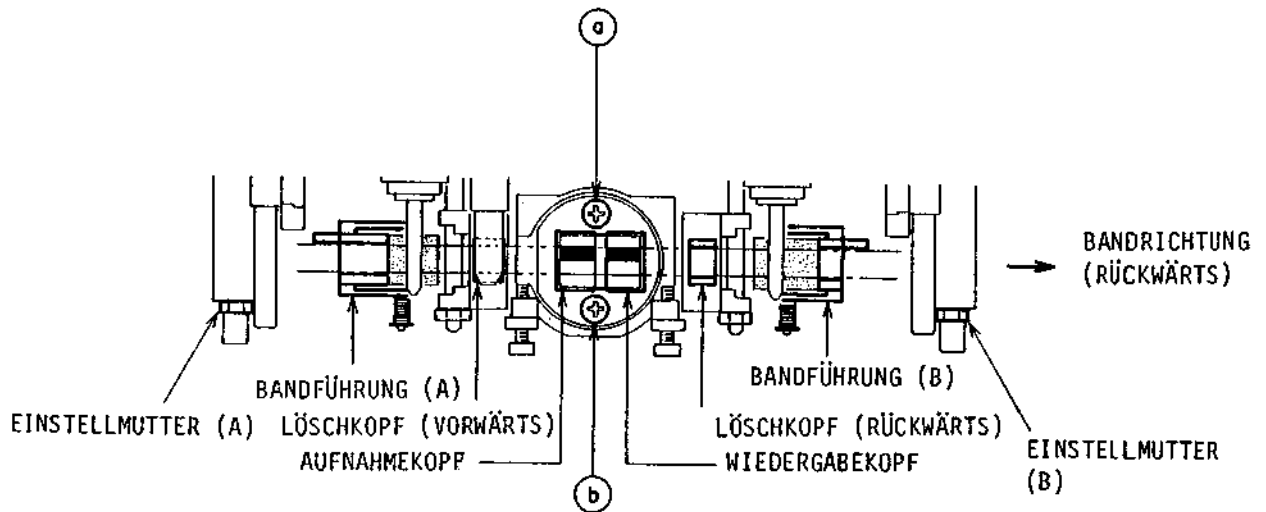
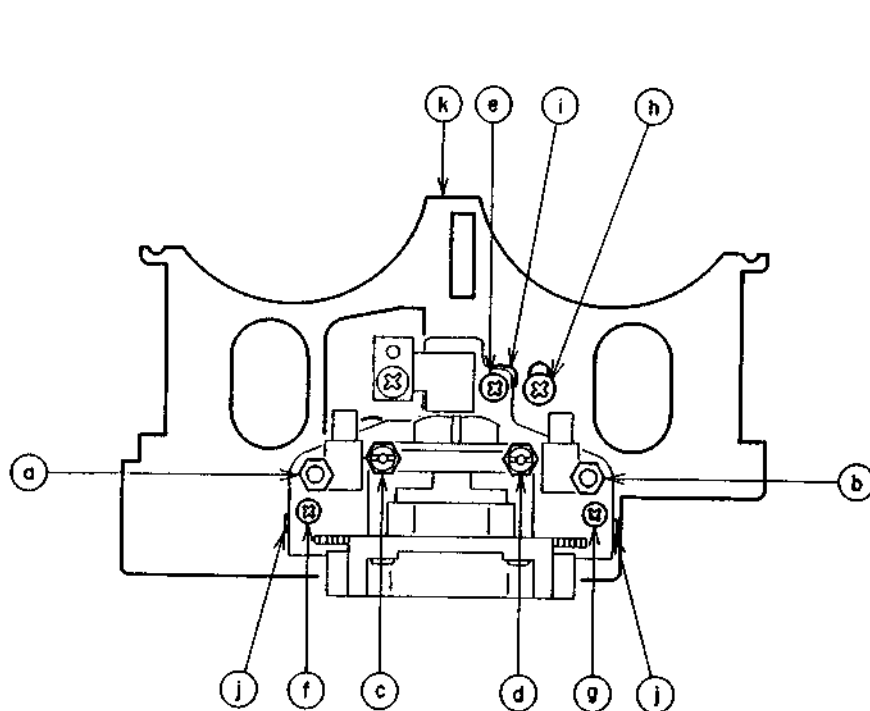
6-1 EINSTELLUNG DER BANDFÜHRUNGSHÖHE (Siehe Abb. 6-1 und 6-2)

6-1-1 Nach Austausch des Andruckrollenblocks

- a) Eine Spiegelcassette (AJ-751178) einlegen.
- b) Wenn nur der Andruckrollenblock (L) ausgetauscht wurde, wählt man die Betriebsart FWD PLAY und stellt die Höhe der Bandführung (A) durch Drehen

- der Mutter (A) so ein, daß das Band am angrenzenden Rand beider Bandführungen reibungslos läuft und das Band keinerlei Verformungen aufweist.
- c) Wenn nur der Andruckrollenblock (R) ausgetauscht wurde, wählt man die Betriebsart REV PLAY und stellt die Höhe der Bandführung (B) durch Drehen der Mutter (B) in der gleichen Weise wie im Abschnitt b) ein.
- d) Nach der Einstellung Siegelack auf diese Muttern auftragen.

6-1-2 Nach Austausch des Löschkopfes (Siehe. Abb. 6-1 und 6-2)

- a) Eine 315 oder 333 Hz Wiedergabepegel-Einstellcassette (AT-750773) einlegen und die Betriebsart FWD PLAY wählen.
- b) Die Löschkopfhöhe durch Drehen der Muttern (a) und (b) wie in Abb. 6-2 gezeigt so einstellen, daß der Line Out Pegel $-5,5$ dBm, 315 Hz bzw. $-6,1$ dBm, 333 Hz beträgt.
- c) Die REV PLAY-Betriebsart wählen und die Löschkopfhöhe durch Drehen der Muttern (a) und (b) nochmals einstellen, so daß die Pegeldifferenz (linker Kanal) zwischen den Betriebsarten FWD und REV innerhalb $\pm 0,5$ dBm liegt.
- d) Die Einstellungen der Abschnitte a), b) und c) wiederholen.
- e) Eine Spiegelcassette (AJ-751178) einlegen und die Betriebsart FWD PLAY wählen.
- f) Die Höhe der Bandführung (A) durch Drehen der Mutter (A) und die Höhe des Löschkopfes (REV) durch Drehen der Mutter (B) so einstellen, daß das Band ohne Verformung an den Bandführungskanten vorbeiläuft.
- g) Als nächstes die Betriebsart REV PLAY wählen und die Höhe der Bandführung (B) durch Drehen der Mutter (B) so einstellen, daß das Band ohne Verformung glatt über die angrenzenden Ränder beider Löschköpfe (FWD und REV) läuft.
- h) Sicherstellen, daß der Line-Ausgangspegel (linker Kanal) $-5,5$ dBm und die Pegeldifferenz (linker Kanal) zwischen den Betriebsarten FWD und REV innerhalb von $\pm 0,5$ dBm liegt.

6-2 KOMBIKOPF-AZIMUTH-EINSTELLUNG (Siehe Abb. 6-2)

Eine 10kHz-Kopf Azimuth-Einstellcassette (AT-750778) wiedergeben und die Schrauben (c) (FWD-Richtung) und (d) (REV-Richtung) so einstellen, daß die Pegel beider Kanäle Maximum betragen. (Hinweis: die Schrauben nicht zu weit drehen, da andere (falsche) Maximalwerte weiter entfernt auf beiden Seiten der korrekten Position existieren.)

6-3 EINSTELLUNG DER KOPFHÖHE (Siehe Abb. 6-1 und 6-2)

Diese Einstellung ist nicht erforderlich, da dieses Modell GX-R99 mit einem rotierenden Kopfsystem (mit Aufnahme- und Wiedergabe-Kombikopf) ausgestattet ist. Die Überprüfung der korrekten Kopfhöhe ist jedoch erforderlich und wird wie folgt ausgeführt:

- 1) Sicherstellen, daß der Azimuth nach Abschnitt 6-2 korrekt ist.
- 2) Eine 315 Hz (oder 333 Hz) Wiedergabepegel-Einstellcassette (AT-750773) in der FWD Wiedergabe-Betriebsart abspielen und den Wiedergabepegel-Einsteller (VR5 an der Vorverstärker-Leiterplatte) so einstellen, daß der LINE OUT-Pegel des linken Kanals $-5,5$

dBm beträgt.

Danach den Pegel des gleichen Kanals in der REV-Betriebsart überprüfen. Die Pegeldifferenz zwischen der FWD und der REV-Betriebsart sollte sich innerhalb $\pm 0,5$ dBm bewegen.

- 3) Wenn im Abschnitt 2 die Differenz mehr als $\pm 0,5$ dBm beträgt, werden die Löschköpfe durch Drehen beider Löschkopfhöhen-Einstellschrauben (a) und (b) in der gleichen Richtung um $1/4$ Drehung ($\pm 0,1$ mm) so eingestellt, daß die Differenz innerhalb $\pm 0,5$ dBm liegt.

- 4) Wenn durch Vornahme der obigen Einstellung die Differenz nicht korrigiert werden kann, ist eine Kopfhöhen-Einstellung erforderlich. Dies kann durch Auswechseln der Abstandshalter zur Einstellung der Kopfhöhe (i) und (j) vorgenommen werden (die Dicke dieser Abstandshalter beträgt (i) = $0,45$ mm, (j) = $0,35$ mm). Zum Austausch der Abstandshalter sind Schrauben (e) und (f) lösen. Wenn der Pegel in der REV-Betriebsart niedriger ist, bedeutet dies, daß der Kopf zu hoch ist, in diesem Falle sind die Abstandshalter gegen dünnere auszutauschen. Wenn der Pegel in der REV-Betriebsart höher ist, sind die Abstandshalter gegen dickere auszutauschen.

Nach dem Austausch dieser Abstandshalter ist die gleiche Einstellung in Abschnitt 1) vorzunehmen und sicherzustellen, daß der Pegel von LINE OUT $-5,5$ dBm $\pm 0,5$ dBm beträgt.

Ferner zur Überprüfung eine 4-Spur-Kopfhöhen-Einstellcassette (1 kHz/4 Spur, At-750775) abspielen. Der LINE-Ausgangspegel beider Kanäle sollte mehr als -8 dBm betragen und die Pegeldifferenz zwischen den Betriebsarten FWD und REV sollte innerhalb ± 1 dB liegen. Andernfalls ist die Feineinstellung in der gleichen Weise vorzunehmen wie im Abschnitt 3) und 4).

- 5) Ist ein Austausch des Kopfes erforderlich, löst man nur die Schrauben (a) und (b) in Abb. 6-1.

6-4 EINSTELLUNG DES KOPFBLOCK-VORSPRUNGS

Eine Tonkopfvorsprungs-Meßvorrichtung (AT-751180) verwenden und die Wiedergabebetriebsart FWD oder REV wählen. Die Schraube (h) lösen und das Kopfträgerchassis (k) so einstellen, daß das Meßgerät $3,1 \pm 0,15$ mm anzeigt. Nach der Einstellung Siegellack auf die Schraube (h) auftragen.

- HINWEIS:
1. Vor der Kopfeinstellung auf jeden Fall die Köpfe reinigen.
 2. Darauf achten, daß keine magnetischen Schraubenzieher oder sonstige magnetische Werkzeuge in der Umgebung der Köpfe verwendet werden.
 3. Vor und nach der Kopfeinstellung auf jeden Fall die Tonköpfe mit einer Entmagnetisierungs-drossel entmagnetisieren.

VII. ELEKTRISCHER ABGLEICH

7-1 EINSTELLUNG DER QUICKREVERSE-EMPFINDLICHKEIT

(Siehe Abb. 7-1 und 7-2)



Abb. 7-1 Einstellpunkte an der SYS-CON LEITERPLATTE



Abb. 7-2

- Durch Entnahme des Bandes aus den Cassettengehäuse eine bandlose Cassette herstellen.
 - Das Digitalvoltmeter zwischen Testpunkt und Masse anschließen.
 - Unter Verwendung der bandlosen Cassette VR201 (an der SYS-CON LEITERPLATTE) so einstellen, daß das Digitalvoltmeter in der FWD Wiedergabe $4,30 \pm 0,05$ V-Gleichspannung anzeigt.
(Die TUNING LEITERPLATTE kann vor der ANZEIGE-LEITERPLATTE abgetrennt werden.)
- HINWEIS: Vor dieser Einstellung den Referenzstift und den Löschkopf (FWD-Seite) reinigen. (Siehe Abb. 7-2)

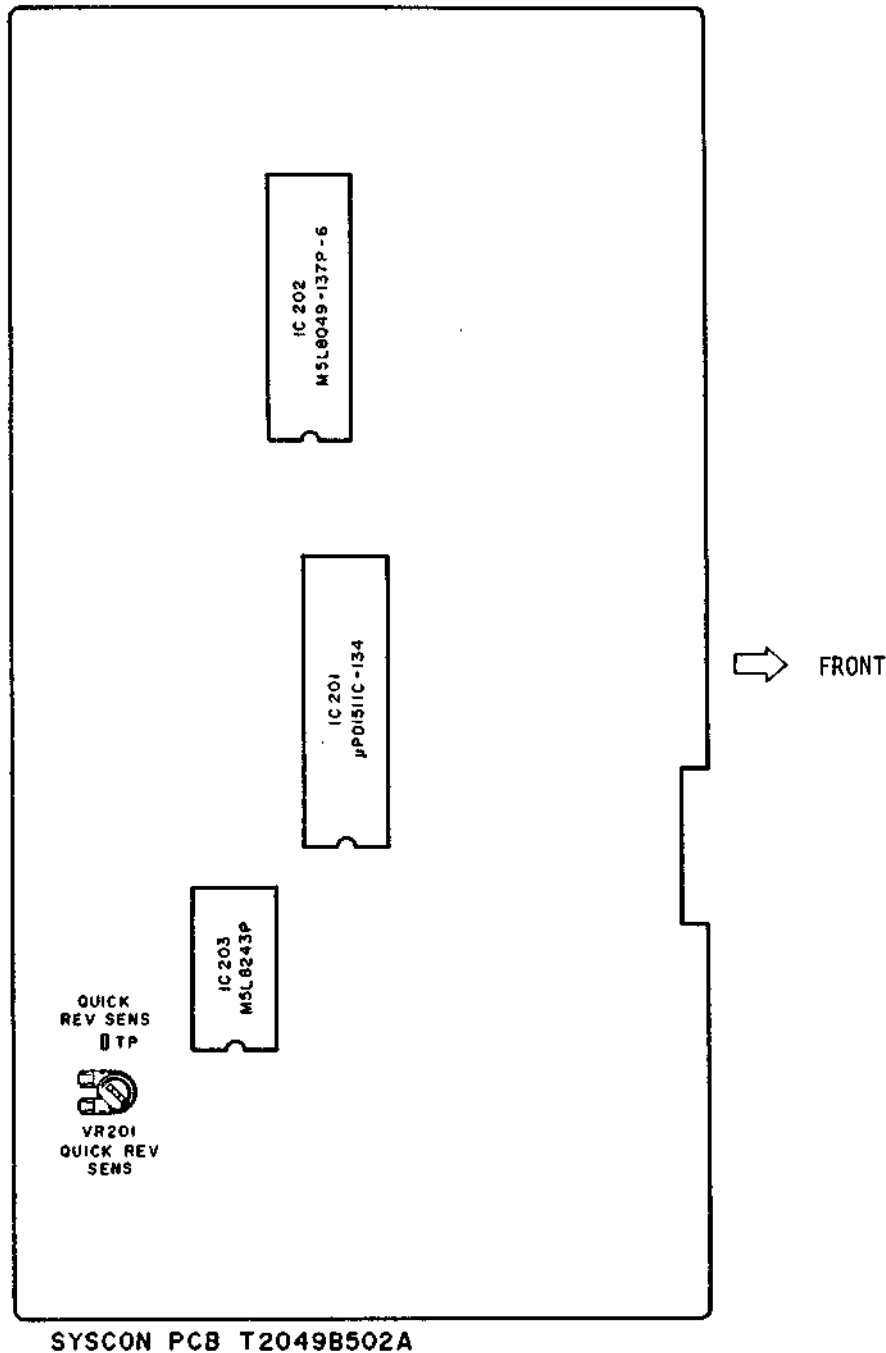
7-2 ABGLEICH DER VORVERSTÄRKER-LEITERPLATTE

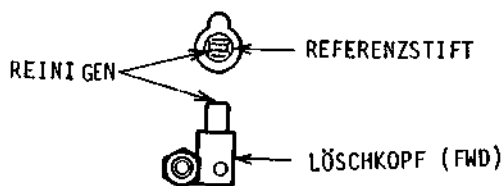

Abb. 7-3 Vorverstärker-Leiterplatte



Abb. 7-4

VORVERSTÄRKER-ABGLEICH-TABELLE

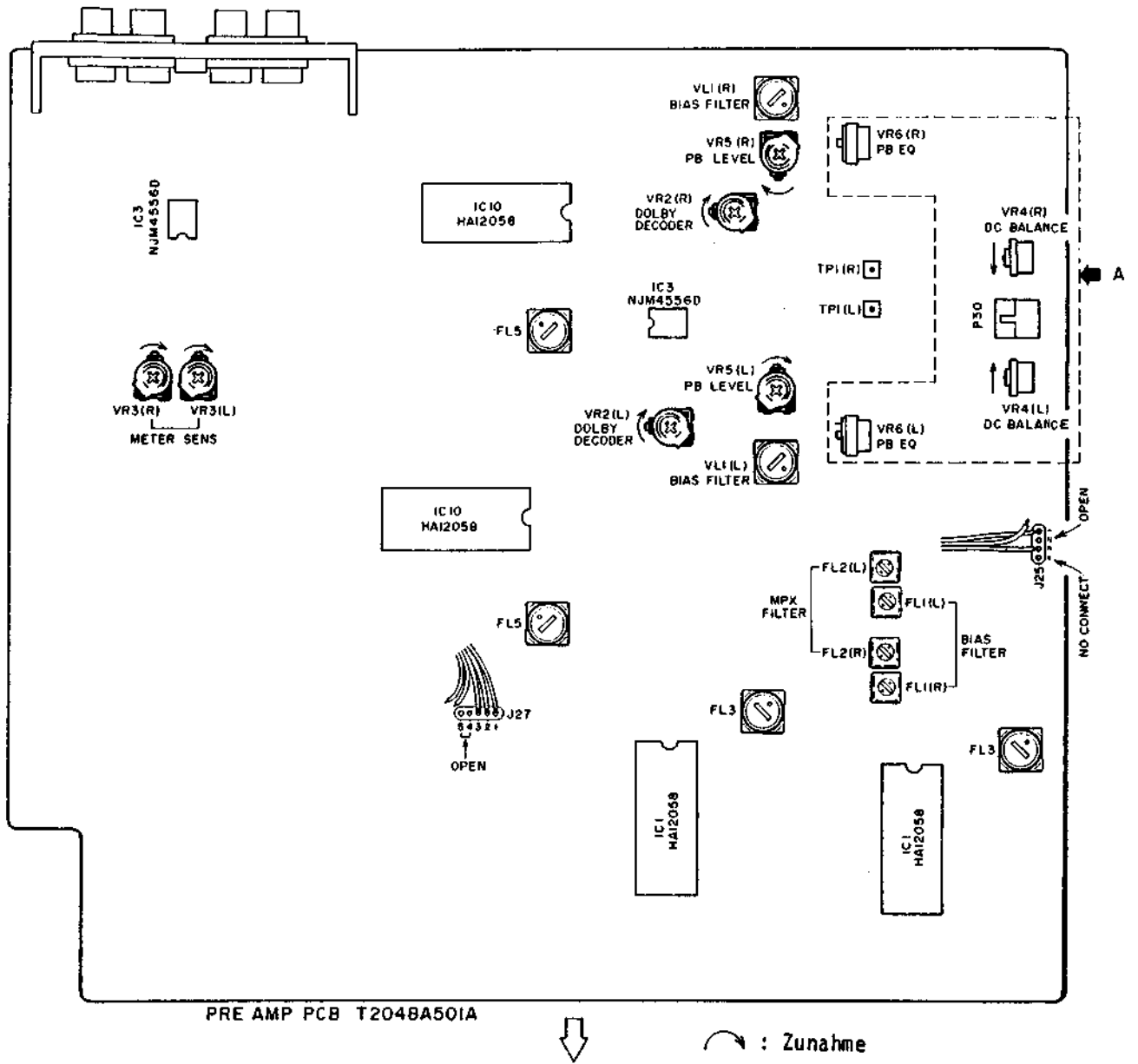
(für weitere Einzelheite, Siehe 7-2-1 bis 7-2-3)

Schritt	Abgleich-gegenstand	Betriebsart	Testcassette und angelegtes Signal	Abgleichpunkt	Ergebnis
1	DC Balance	STOP	Connect INPUT PIN of P30 with GND	VR4(L) VR4(R)	TP1(L) TP1(R) $0 \pm 100\text{mV D.C}$
2	P.B Level	FWD PLAY	333 Hz 0 VU Tape (315 Hz 0 VU Tape)	VR5(L) VR5(R)	LINE OUT $-6,1 \pm 0,1\text{dBm}$ $(-5,5 \pm 0,1\text{dBm})$
		REV PLAY	333 Hz 0 VU Tape (315 Hz 0 VU Tape)	Überprüfung	
3	P.B EQ	FWD PLAY	10 kHz P.B EQ Tape	VR6(L) VR6(R)	LINE OUT $-20,5 \pm 0,2\text{dBm}$
		REV PLAY	10 kHz P.B EQ Tape	Überprüfung	$-20,5 \pm 2,0\text{dBm}$
4	ANZEIGE-Empfindlichkeit	TAPE MONITOR SOURCE	1 kHz LINE IN ($-5,2\text{ dBm LINE OUT}$)	VR3(L) VR3(R)	+1 VU Anzeige auf dem VU METER
5	Dolby Decoder	FWD PLAY	315 Hz 0 VU Tape (333 Hz 0 VU Tape)	VR2(L) VR2(R)	LINE OUT $-5,5 \pm 0,3\text{dBm}$ Mit Dolby $(-6,1 \pm 0,3\text{dBm})$
6	MPX Filter	REC	19 kHz LINE IN	FL2(L) FL2(R)	LINE OUT MIN Mit MPX SW
7	BIAS Filter (Source)	REC/PLA. REC/PAUSE	Ohne Signal Reineisenbande (REC VR MAX)	FL1(L) FL1(R)	LINE OUT MIN
8	BIAS Filter (P.B)	REC/PLAY	Ohne Signal Reineisenband	VL1(L) VL1(R)	LINE OUT MIN

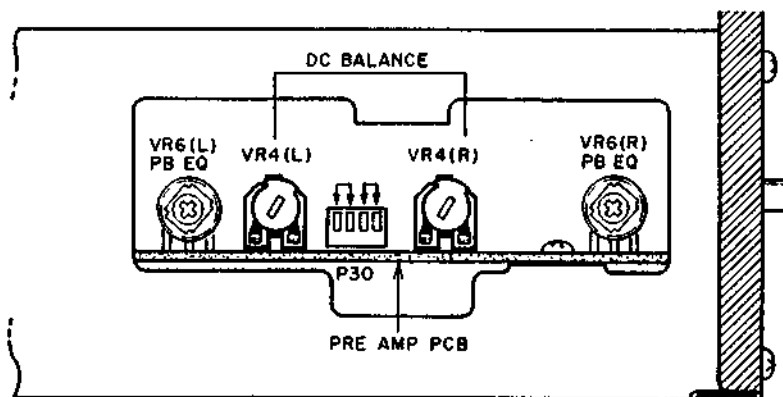
7-2-1 ABGLEICH DES WIEDERGABEENTZERRERVERSTÄRKERS (TUNING-LEITERPLATTE ist von der ANZEIGE-LEITERPLATTE abtrennbar)

- 1) DC Balance
 - a. Den Anschlußstecker von P30 entfernen (WIEDERGABEKOPF-Anschlußstecker)
 - b. Den INPUT SIGNAL PIN (Eingangssignalstift) von P30 Stift 1, 4 an Masse anschließen.
 - c. VR4 so einstellen, daß die Spannung am TP1 $0 \pm 100\text{mV}$ -Gleichspannung beträgt.

- 2) Wiedergabepegel
 - a. Mit FWD eine 333Hz-Wiedergabe-Einstellcassette (AT-750773) oder eine 315 Hz-Wiedergabe-Einstellcassette (AT-750773) abspielen und VR5 so einstellen, daß der LINE OUT-Pegel bei 333 Hz $-6,1 \pm 0,1\text{ dBm}$ bzw. bei 315 Hz $-5,5 \pm 0,1\text{ dBm}$ beträgt.
 - b. Mit REV Wiedergabe eine 333 Hz oder 315Hz-Wiedergabe-Pegel-Einstellcassette abspielen und sicherstellen, daß der LINE OUT-Pegel $-6,1 \pm 0,6\text{ dBm}$ (333 Hz) bzw. $-5,5 \pm 0,6\text{ dBm}$ (315 Hz) beträgt.

- 3) Wiedergabeentzerrung
 - a. Eine 10kHz-Wiedergabeentzerrungs-Einstellcassette (AT-750778) im FWD-Richtung abspielen und VR6 so einstellen, daß der LINE OUT-Pegel $-20,5 \pm 0,2\text{ dBm}$ beträgt.
 - b. Eine 10kHz-Wiedergabeentzerrungs-Einstellcassette in REV-Richtung abspielen und sicherstellen, daß der LINE OUT-Pegel $-20,5 \pm 1,0\text{ dBm}$ beträgt.

7-2-2 ABGLEICH DER ANZEIGE-EMPFFINDLICHKEIT

- a. Den Monitorschalter auf SOURCE und den Anzeige um schalter auf VU schalten. Ein 1kHz-Signal an LINE IN und ein 1kHz-Signal $-5,2\text{ dBm}$ an LINE OUT anlegen.
- b. VR3 so abgleichen, daß +1 VU erreicht wird.

7-2-3 DOLBY-ABGLEICH

- 1) Dolby-Decoder-Abgleich
 - a. Eine 315Hz-Wiedergabepegel-Einstellcassette (AT-750773) abspielen.
 - b. VR2 so abgleichen, daß der LINE OUT-Pegel bei Dolby EIN $-5,5 \pm 0,3$ dBm beträgt. (Bei Verwendung der 333Hz-Wiedergabepegel-Einstellcassette beträgt der LINE OUT-Pegel $-6,1 \pm 0,3$ dBm.

- 2) MPX-Filter-Abgleich
 - a. Eine Leercassette einlegen und die REC/PLAY-Betriebsart einschalten.
 - b. Mit dem MPX-Filter-Schalter in der AUS-Stellung ein 19kHz-Signal über LINE IN anlegen.
 - c. FL2 so abgleichen, daß der LINE OUT-Pegel Minimum beträgt, wenn der MPX-Filter-Schalter eingeschaltet wird.

- 3) BIAS-Filterabgleich
 - a. Eine Reineisenband-Cassette einlegen und die REC/PLAY-Betriebsart einschalten (bzw. REC/PLAY REC/PAUSE)
 - b. FL1 so abgleichen, daß der LINE OUT-Pegel Minimum beträgt, wenn die Aussteuerung auf MAX eingestellt ist und der Monitorschalter auf SOURCE steht.
 - c. Eine Reineisenband-Cassette einlegen und die REC/PLAY-Betriebsart einschalten.
 - d. VL1 so abgleichen, daß der LINE OUT-Pegel Minimum beträgt, wenn der Monitorschalter auf TAPE gestellt wird.

7-3 EINMESS-ABGLEICHPUNKTE

TUNING PCB T2049A5010



Abb. 7-5 Abgleichpunkte an der Einmess-Leiterplatte

RÜCKSEITE

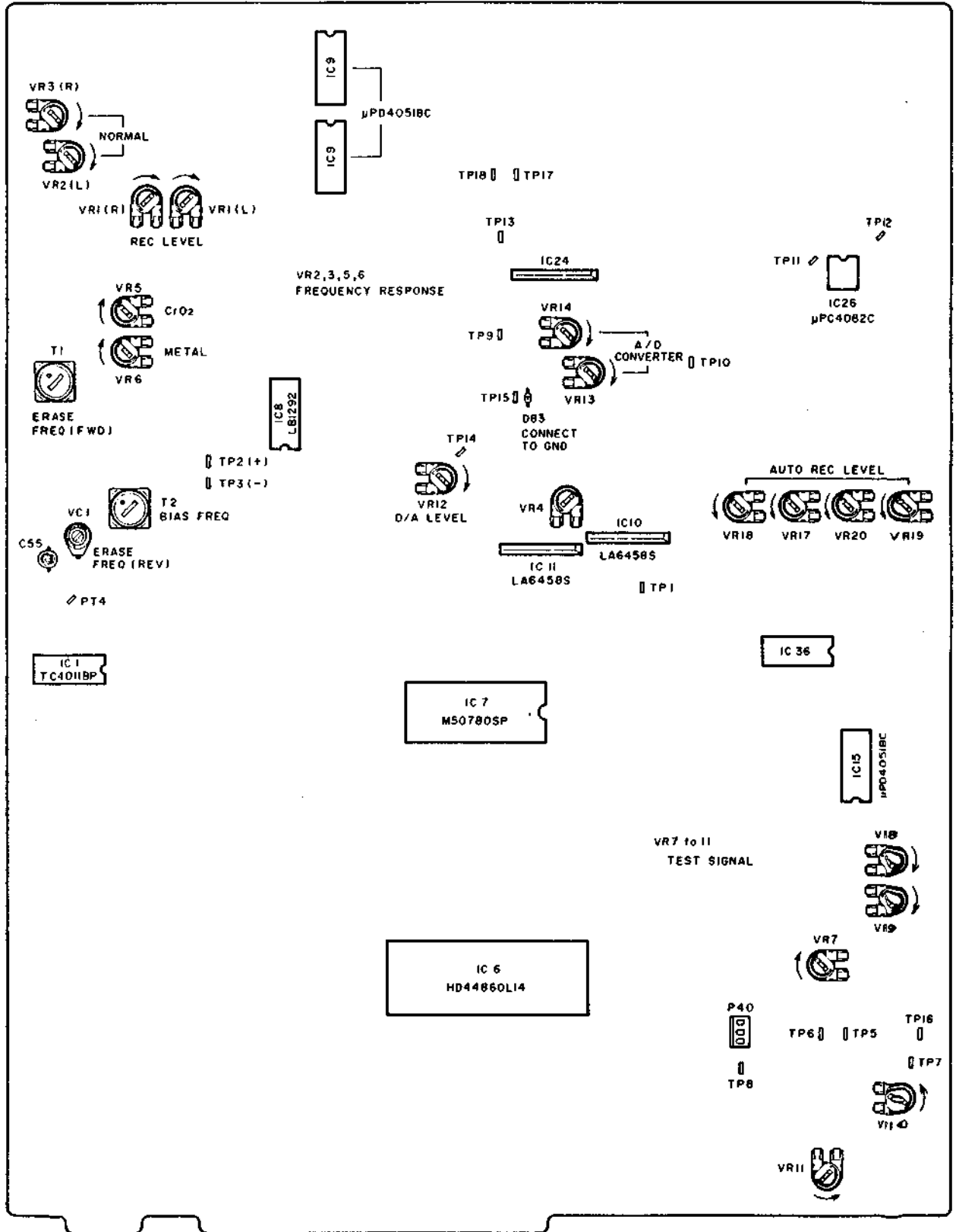
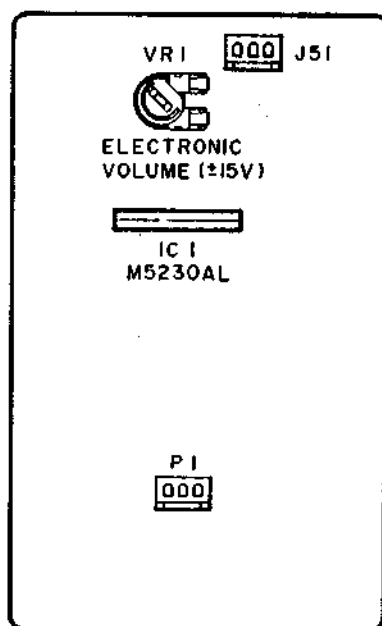

POWER SUPPLY II PCB
T2049D5060

Abb. 7-6 Angleichpunkte an der Netzteil II LEITERPLATTE

EINMESS-ABGLEICH TABELLE

(Für weitere Einzelheiten, siehe 7-3-1 bis 7-3-10)

Schritt	Abgleichgegenstand	Betriebsart	Testcassette Angelegtes Signal	Abgleichpunkt	Ergebnis
1	D/A Level	CRIP OFF REC VR MAX		VR12	TP14 $5,5 \pm 0,05$ V DC
2	Netzteil (± 15 V) für VCA	REC VR MAX	1 kHz LINE IN	AUDIO OSC Level	LINE OUT $+4,5$ dBm
			1 kHz LINE IN	REC VR	$+2,08$ V DC TP14 $+2,16$ V DC
			1 kHz LINE IN	VR1 (am Netzteil II)	LINE OUT $-11,5 \pm 0,2$ dBm
3	Test Signal (400 8K)	J27 (4)(5) J25 (2) ablöten (am Vorver- stärker) REF-Betriebs- art REC/PAUSE		VR9	LINE OUT 8 KHz $-5,5 \pm 0,2$ dBm
			TP5 und TP6 mit Masse verbinden	VR7	LINE OUT 400 ± 2 Hz
				VR8	LINE OUT $-5,5 \pm 0,2$ dBm
			TP5, TP6 mit Masse verbinden TP16, TP17 direkt verbinden	VR4	TP1 Minimal wechselfspannung

Schritt	Abgleichgegenstand	Betriebsart	Testcassette Angelegtes Signal	Abgleichpunkt	Ergebnis
4	Test Signal (1K 10K)	Gleich wie Schritt 3	TP7 und TP16 mit Masse verbinden		LINE OUT 1 kHz
			TP7, TP16 und TP8 mit Masse verbinden	VR10	LINE OUT 10 kHz gleicher Pegel wie 1 kHz
			TP7, TP6 mit Masse verbinden	VR11	LINE OUT $-25,5 \pm 0,2$ dBm
5	REC BIAS OSC	REF Mode FWD/PLAY → REC/PAUSE (In REC II)	METAL Tape	T1	TP4 $100 \pm 0,2$ kHz
		REF Mode REV/PLAY → REC/PAUSE (In REC II)	METAL Tape	VC1	TP4 100 ± 1 kHz (auch bei abgetrenntem C55)
		METAL Tape	T2	Zwischen TP2 (+) und TP3 (-) Minimalgleich- spannung	
6	Frequenzgang (NORMAL)	REF Mode FWD REC/P.B	NORMAL Tape 1 kHz, 10 kHz ($-25,5$ dBm LINE OUT)	VR2(L) VR3(R)	LINE OUT 1K, 10K Gleich
		REV REC/P.B	Gleich wie FWD		Gleich (überprüfung)
	(CrO ₂)	REF Mode FWD REC/P.B	CrO ₂ Tape 1 kHz, 10 kHz ($-25,5$ dBm LINE OUT)	VR5	LINE OUT 1K, 10K Gleich
		REV REC/P.B	Gleich wie FWD		Gleich (überprüfung)
	(METAL)	REF Mode FWD REC/P.B	METAL Tape 1 kHz, 10 kHz ($-25,5$ dBm LINE OUT)	VR6	LINE OUT 1K, 10K Gleich
		REV REC/P.B	Gleich wie FWD		Gleich (überprüfung)
7	Aufnahmepegel	REF Mode FWD REC/P.B	NORMAL Tape 1 kHz ($-5,5$ dBm LINE OUT)	VR1(L) VR1(R)	LINE OUT $-5,5 \pm 0,2$ dBm
		REV REC/P.B	Gleich wie FWD		FWD Ergebnis $-0,5$ dBm
8	A/D CONVERTER	J27 (4)(5) ablöten TP10, B von TR81 mit Masse verbinden	$-5,0 \pm 0,2$ dBm 1 kHz to TP18	VR14	TP9 $+1,5 \pm 0,05$ VDC
		Nur TP10 öffnen	$-24,7 \pm 0,2$ dBm 1 kHz to TP18	VR13	TP9 $+2,5 \pm 0,05$ VDC

Schritt	Abgleichgegenstand	Betriebsart	Testcassette Angelegtes Signal	Abgleichpunkt	Ergebnis
9	Automatische Aussteuerung	REC VR MAX TP13 mit Masse verbinden	400 Hz to LINE IN(L) (+4,5 ± 0,2 dBm LINE OUT)	VR17(L)	TP11 +1,5 ± 0,05 V DC
			400 Hz to LINE IN(R) (+4,5 ± 0,2 dBm LINE OUT)	VR18(R)	TP11 +1,5 ± 0,05 V DC
			8 kHz to LINE IN(L) (+4,5 ± 0,2 dBm LINE OUT)	VR19(L)	TP12 +1,5 ± 0,05 V DC
			8 kHz to LINE IN(R) (+4,5 ± 0,2 dBm LINE OUT)	VR20(R)	TP12 +1,5 ± 0,05 V DC

7-3-1 Referenz-Betriebsart (REF)

- 1) Alle die Aufnahme betreffenden Einstellungen müssen in der REF-Betriebsart vorgenommen werden.
- 2) Einschalten der REF-Betriebsart
 - a. Das Gerät einschalten und die Auswurf Taste drücken.
 - b. Das Gerät ausschalten und eine SPECIAL METAL Cassette einlegen, deren CrO₂(70 u) Kennungsöffnung mit Klebeband verdeckt ist. (Die Reineisenband Kennungsöffnung wird nicht verdeckt.) Die REF-Betriebsart wird automatisch 4 Sekunden nach dem nächsten Einschalten des Gerätes eingeschaltet.

7-3-2 Besondere Hinweise zur REF Betriebsart

- a. Die REF-Betriebsart kann nur durch Ausschalten des Gerätes aufgehoben werden.
- b. In der REF-Betriebsart leuchtet nur die REC-Anzeige, nicht die TUNING-Anzeige auf.
Wenn eine normale Cassette (nicht die im Abschnitt 7-1 verwendete) in dieser Betriebsart benutzt wird und das Gerät wird während der REC/PLAY-Betriebsart ausgeschaltet, leuchtet beim nächsten Einschalten des Gerätes nur die TUNING-Anzeige auf. Bei Betätigung der REC/PAUSE-Taste im obigen Zustand wird bewirkt, daß die REC und die TUNING-Anzeige aufleuchten. In diesem Fall bedeutet das Aufleuchten der TUNING-Anzeige nicht, daß die Einmessung durchgeführt wird, sondern, daß sie beendet und das Gerät zur Aufnahme bereit ist.
- c. Die REC I-Betriebsart ist der Zustand der durch Drücken der REC/PAUSE-Taste während der REF-Betriebsart bewirkt wird.

In dieser REC I-Betriebsart wird das Testsignal stummgeschaltet und der Oszillator gestoppt.
Drücken der Auswurf Taste in dieser Betriebsart bewirkt keine Funktion, selbst wenn die REC/PAUSE-Taste gedrückt wird.

In diesem Falle die STOP-Taste drücken, dann die REC/PAUSE-Taste betätigen, um die REC I-Betriebsart wieder zu erreichen.

- d. Die REC II-Betriebsart kann durch Drücken der PLAY-Taste (FWD oder REV) je nach der in der REC I-Betriebsart durch die PLAY-Taste angezeigten Richtung eingeschaltet werden.

Wird die PLAY-Taste nur kurzzeitig betätigt, geht das Gerät in den REC II Zustand, aber mit der REC/PAUSE Funktion.

Um in REC II Zustand die REC/PLAY Funktion zu erreichen, muß die PLAY-Taste länger als 1 Sekunde betätigt werden.

In der Betriebsart REC II wird die Stummenschaltung des Testsignals und die Blockierung des Oszillators aufgehoben.

7-3-3 D/A PEGELABGLEICH

- a. Die CRIP-Betriebsart ausschalten und REC VR auf Maximum einstellen.
- b. VR12 so abgleichen, daß die Spannung gegen Masse von TP14 $5,0 \pm 0,05$ -Gleichspannung beträgt.

7-3-4 VERSORGUNGSSPANNUNG (± 15 V) DER ELEKTRONISCHEN PEGELREGELUNG (VCA)

- REC VR auf MAX stellen.
- Ein Sinussignal von 1 kHz an LINE IN anlegen und den Audio-Generator Ausgangsregler so einstellen, daß LINE OUT $\pm 4,5$ dBm beträgt.
- REC VR so abgleichen, daß die Spannung von TP14 gegen Masse $+2,08$ V bis $+2,16$ beträgt.
- VR1 (NETZTEIL II LEITERPLATTE, siehe Abb. 7-6) so abgleichen, daß der LINE OUT-Pegel $-11,5 \pm 0,2$ dBm beträgt.

7-3-5 TESTSIGNALABGLEICH

- Die an J27*1 (4), (5) J25*2 (2) in der Vorverstärker-Leiterplatte angeschlossenen Leitung ablöten. (Siehe Abb. 7-3.)
- In der REF-Betriebsart die REC/PAUSE-Betriebsart einschalten.
- Ein 8kHz-Signal an LINE OUT anlegen, VR9 so abgleichen, daß der LINE OUT-Pegel $-5,5 \pm 0,2$ dBm beträgt.
- Beim Anschluß von TP5 und TP6 an Masse ist LINE OUT ca. 400 Hz.
- VR7 so abgleichen, daß am LINE OUT 400 ± 2 Hz zu messen sind.
- VR8 so abgleichen, daß der LINE OUT-Pegel $-5,5 \pm 0,2$ dBm beträgt.
- TP16 mit TP17 verbinden, VR4 so abgleichen, daß die Wechselspannung von TP1 gegen Masse Minimum beträgt.
- Die Überbrückung in Abschnitt d und Abschnitt g auftrennen.
- TP7 und TP16 an Masse anschließen, LINE OUT beträgt 1 kHz.
- TP7 TP 16 und TP8 an Masse anschließen, LINE OUT beträgt 10 kHz.
- VR10 so abgleichen, daß der Pegel von Abschnitt i und der Pegel von Abschnitt j gleich sind.
- Nur TP8 öffnen und VR11 so abgleichen, daß der LINE OUT-Pegel $-25,5 \pm 0,2$ dBm beträgt.

*1 : Zum Reduzieren von Verzerrungen und lastbedingter Oszillatorpegelschwankungen.

*2 : Zum Abschalten der LINE OUT STUMMSCHALTUNG.

7-3-6 ABGLEICH DES VORMAGNETISIERUNGS- OSZILLATORS

- In der REF-Betriebsart eine Reineisenbandcassette einlegen und FWD REC/PAUSE \rightarrow FWD PLAY \rightarrow REC/PAUSE (in der REC II-Betriebsart) einschalten.
- Den Frequenzzähler an TP4 anschließen und T1 so abgleichen, daß die Frequenz $100 \pm 0,2$ kHz beträgt.
- Die REV REC/PAUSE-Betriebsart (in der REC II-Betriebsart) einschalten.

- VC1 so abgleichen, daß die Frequenz an TP4 100 ± 1 kHz beträgt. Wenn ein einwandfreies Ergebnis nicht erzielt werden kann, entfernt man C55 (120P) und stellt VC1 so ein, daß die Frequenz 100 ± 1 kHz beträgt.
- Ein Gleichstrom-Voltmeter an TP2 (+) und TP3 (-) anschließen und T2 so abgleichen, daß die Gleichspannung Minimum wird.

7-3-7 EINSTELLUNG DES FREQUENZGANGS

- In der REF-Betriebsart.
- Eine FWD-Aufnahme und -Wiedergabe mit 1 kHz/10 kHz, $-25,5$ dBm auf Normalband machen, VR2 (linker Kanal) und VR3 (rechter Kanal) so einstellen, daß gleicher Pegel bei beiden Frequenzen erzielt wird.
- Unter gleichen Bedingungen wie in b. erläutert eine FWD-Aufnahme und -Wiedergabe auf CrO₂ Kassette machen und mit VR5 auf gleichen Pegel einstellen.
- Reineisenband wird unter den gleichen Bedingungen wie in b. beschrieben mit VR6 eingestellt.
- Der REF Betrieb ist mit allen 3 Bandsorten zu überprüfen.

7-3-8 AUFNAHMEPEGEL-ABGLEICH

- In der REF-Betriebsart.
- Eine FWD-Aufnahme und -Wiedergabe mit 1 kHz, $-5,5$ dBm machen und VR1 so abgleichen, daß die Differenz zwischen Aufnahme- und Wiedergabepegel $0 \pm 0,2$ dBm beträgt.
- Überprüfen, daß die Differenz zwischen FWD und RWD innerhalb $0,5$ dBm liegt.

7-3-9 ABGLEICH DES A/D- UMSETZERS

- Die an J27 (4), (5) in der Vorverstärker-Leiterplatte angeschlossene Leitung ablöten. (siehe Abb. 7-3.)
- TP10 und die Kathode von D83 (oder die Basis von TR81) mit Masse verbinden.
- Ein 1kHz-Sinussignal von $-0,5 \pm 0,2$ dBm an TP18 einspeisen, das Eingangssignal wird zwischen TP18 und Masse gemessen.
- VR14 so abgleichen, daß die Spannung zwischen TP9 und Masse $+1,5 \pm 0,05$ V-Gleichspannung beträgt.
- TP10 öffnen.
- Ein 1kHz-Sinussignal von $-24,7 \pm 0,2$ dBm an TP18 einspeisen; das Eingangssignal wird zwischen TP18 und Masse gemessen.
- VR13 so abgleichen, daß die Spannung von TP9 gegen Masse $\pm 0,05$ V-Gleichspannung beträgt.

7-3-10 ABGLEICH DER AUSSTEUERUNGSAUTOMATIK

Mit diesem Abgleich wird abwechselnd das Eingangssignal für den linken Kanal und den rechten Kanal abgeglichen.

- a. Die an P27 (4), (5) auf der Vorverstärker-Leiterplatte angeschlossene Leitung ablöten, (Siehe Abb. 7-3.)
- b. 400 Hz an LINE IN eingeben und die Aussteuerung auf Maximum stellen. Die Audio-Generator-Ausgangsspannung so einstellen, daß der LINE OUT-Pegel $+4,5 \pm 0,2$ dBm beträgt.
- c. TP13 an Masse legen, VR17 so abgleichen (Abgleich linker Kanal), daß die Spannung zwischen TP11 und Masse $+1,5 \pm 0,05V$ -Gleichspannung beträgt. Danach VR18 (Abgleich rechter Kanal) so abgleichen, daß die Spannung zwischen TP11 und Masse $+1,5 \pm 0,05V$ -Gleichspannung beträgt.
- d. 8 kHz an LINE IN einspeisen und die Aussteuerung auf Maximum einstellen. Die Audio-Generator-Ausgangsspannung so einstellen, daß der LINE OUT-Pegel $+4,5 \pm 0,2$ dBm beträgt.
- e. TP13 mit Masse verbinden, VR19 abgleichen (Abgleich linker Kanal), so daß die Spannung zwischen TP12 und Masse, $+1,5 \pm 0,05V$ -Gleichspannung beträgt. Nachfolgend VR20 (Abgleich rechter Kanal) so abgleichen, daß die Spannung zwischen TP12 und Masse $+1,5 \pm 0,05V$ -Gleichspannung beträgt.

HINWEIS: Zur Messung folgende Kassettentypen verwenden:

Normalband:	Maxell	UD	C-60
CrO Band:	TDK	SA	C-60
Reineisen-			
band:	TDK	MA	C-60

SAFETY INSTRUCTIONS

SAFETY CHECK AFTER SERVICING

Confirm the specified insulation resistance between power cord plug prongs and externally exposed parts of the set is greater than 10 Mohms, but for equipment with external antenna terminals (tuner, receiver, etc.) and is intended for **C** or **A**, specified insulation resistance should be more than 2.2 Mohms (ground terminals, microphone jacks, headphone jacks, line-in-out jacks etc.)

PRECAUTIONS DURING SERVICING

1. Parts identified by the **Δ** symbol parts are critical for safety.
Replace only with parts number specified.
2. In addition to safety, other parts and assemblies are specified for conformance with such regulations as those applying to spurious radiation. These must also be replaced only with specified replacements.
Examples: RF converters, tuner units, antenna selector switches, RF cables, noise blocking capacitors, noise blocking filters, etc.
3. Use specified internal wiring. Note especially:
 - 1) Wires covered with PVC tubing
 - 2) Double insulated wires
 - 3) High voltage leads
4. Use specified insulating materials for hazardous live parts. Note especially:
 - 1) Insulation Tape
 - 2) PVC tubing
 - 3) Spacers (Insulating Barriers)
 - 4) Insulation sheets for transistors
 - 5) Plastic screws for fixing microswitch (especially in turntable)
5. When replacing AC primary side components (transformers, power cords, noise blocking capacitors, etc.), wrap ends of wires securely about the terminals before soldering.

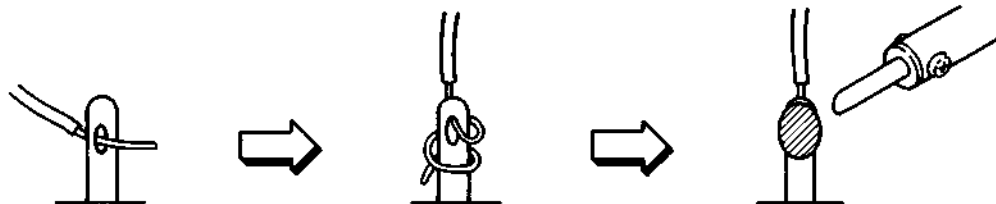

6. Observe that wires do not contact heat producing parts (heatsinks, oxide metal film resistors, fusible resistors, etc.).
7. Check that replaced wires do not contact sharp edged or pointed parts.
8. Also check areas surrounding repaired locations.
9. Use care that foreign objects (screws, solder droplets, etc.) do not remain inside the set.

VOLTAGE CONVERSION

Models for Japan, Canada, USA, Europe, UK and Australia are not equipped with this facility. Each machine is preset at the factory according to destination, but some machines can be set to 110V, 120V, 220V or 240V as required. If your machine's voltage can be converted:

1. Disconnect the power cord.
2. Turn the voltage selector located on the Rear panel with a screwdriver until the correct voltage is indicated.

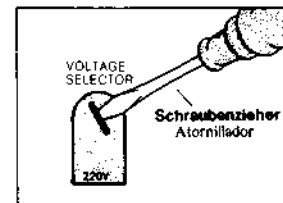

CYCLE CONVERSION

With DC MOTOR, CYCLE CONVERSION is not necessary.

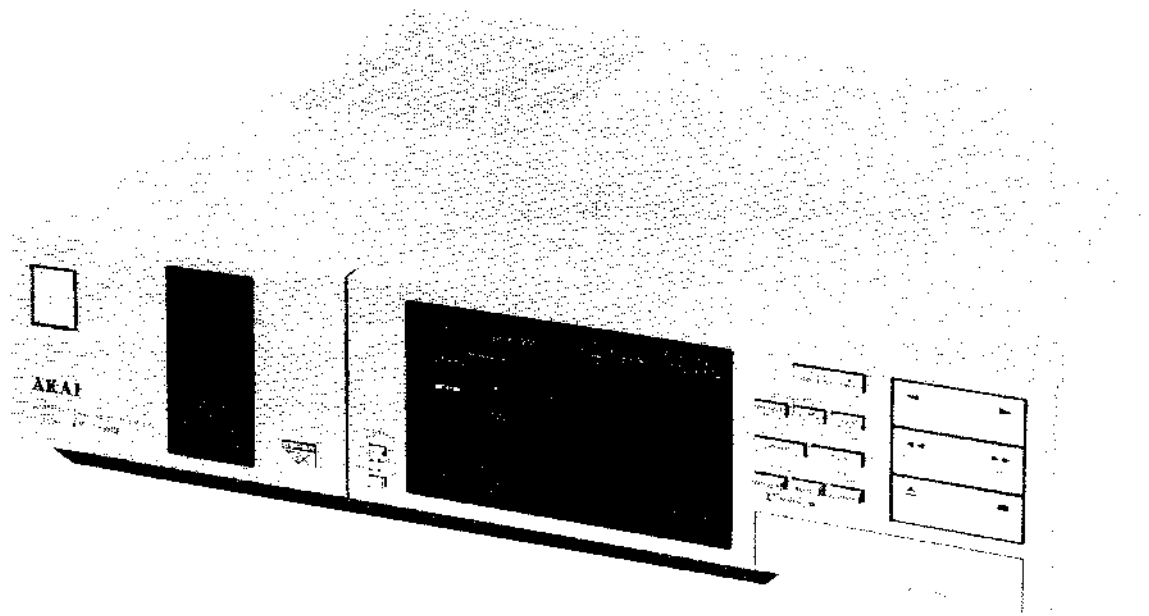

STEREO CASSETTE DECK

MODEL GX-R99

SECTION 1	OPERATING MANUAL	3
SECTION 2	SERVICE MANUAL	19
SECTION 3	PARTS LIST	51
SECTION 4	BLOCK AND SCHEMATIC DIAGRAMS ...	69

SECTION 1

OPERATING MANUAL

TABLE OF CONTENTS

LET'S RECORD (MANUAL)	4
LET'S RECORD (CRLP)	6
A LITTLE KNOW-HOW GOES A LONG WAY	8
LET'S PLAY BACK THE TAPE	10
CONVENIENT PLAYBACK FEATURES USING THE AUTO SYSTEM	12
WHAT YOU SHOULD KNOW	14
THE AUTO MONITOR SYSTEM	15
... AND THEN SOME	16
THE MPX FILTER SWITCH	17
ABSENTEE RECORDING AND TIMED PLAY BACK	18



Let's record (Manual) Faisons un enregistrement (manuel)

Get ready

1. The **TIMER START** switch is set to **OFF** (▲).
2. The **OUTPUT/PHONES** control is set to around 5.
3. Depress the **POWER** switch to turn on the Akai GX-R99.

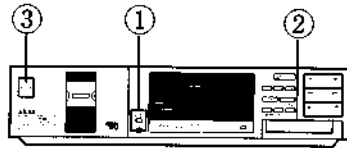

1. Depress the **REV.** selector to change from single side to two sided recording. Note: The **REV.** selector is automatically set to continuous play when the GX-R99 is first turned on.
2. Set the tape length by depressing the **TAPE** button repeatedly (C90, C60, C46, LC46). Refer to page 13.
3. Select the counter by depressing the **MODE** button repeatedly.
4. Set the counter to "0000" by depressing the **RESET** button. Refer to page 13.
5. Set the **DOLBY NR** button to **ON**.
6. Set the **DOLBY B/C** button to your preference. Refer to page 19.
7. Set the **MPX** button. Refer to page 21.

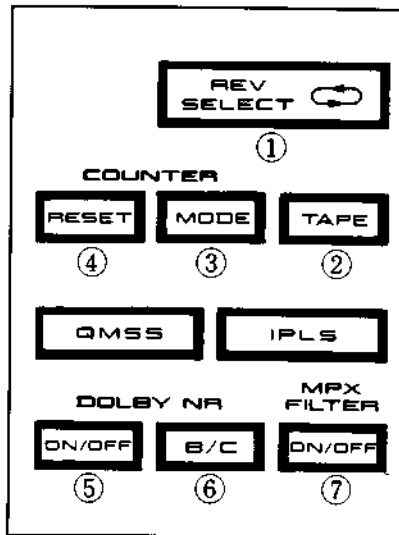

Préparation

1. Le sélecteur de démarrage de la minuterie (**TIMER START**) est placé sur **OFF** (▲).
2. La commande sortie/casques est placée vers 5.
3. Appuyer sur le compteur d'alimentation pour mettre le Akai GX-R99 sous tension.

1. Enfoncer le sélecteur **REV** (retour) pour faire varier l'enregistrement d'une seule face à deux faces. Note: le sélecteur **REV** se règle automatiquement sur lecture continue lorsque l'on met le GX-R99 sous tension.
2. Régler la longueur de bande en appuyant sur la touche **TAPE** (bande) (C90, C60, C46, LC46). Se reporter à la page 13.
3. Choisir le compteur en appuyant sur le bouton **MODE**.
4. Régler le compteur à "0000" en appuyant sur la touche réinitialisation (**RESET**). Se reporter à la page 13.
5. Placer la touche **DOLBY NR** sur **ON**.
6. Placer la touche **DOLBY B/C** selon votre choix. Se reporter à la page 19.
7. Régler la touche **MPX**. Se reporter à la page 21.

Manual operation

By depressing the **MANU OFF (CRLP)** button, the **CRLP** system will automatically set the tape sensitivity, equalization and bias but not the recording volume level.

AT BIAS

Use the **AT BIAS** button to select a tape bias at standard (**STD**), higher bias (**OVER**), or lower bias (**UNDER**). Refer to page 11.

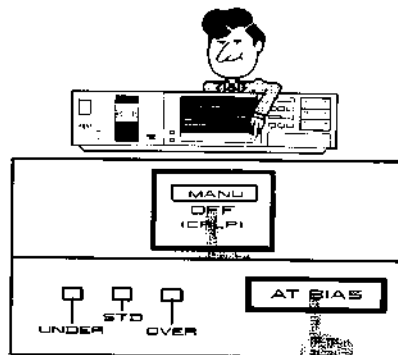

Fonctionnement manuel

Le système **CRLP** réglera automatiquement la sensibilité de la bande, la polarisation et l'égalisation en appuyant sur la touche **MANU OFF (CRLP)**. Le volume d'enregistrement ne sera pas ajusté.

AT BIAS

Utiliser la touche polarisation (**AT BIAS**) pour placer la polarisation sur standard (**STD**), polarisation supérieure (**OVER**) ou polarisation inférieure (**UNDER**). Se reporter à la page 11.

Depress the **EJECT** (▲) button and load a cassette tape.

Direct lead-in

Don't close the cassette holder. The Akai GX-R99 is equipped with a direct lead-in system. When you depress a tape transport button (●, ▶, ◀, ▶▶, ■), the cassette holder will close automatically.

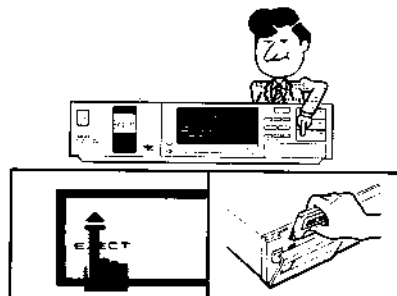

Appuyer sur la touche d'éjection (**EJECT** ▲) et placer une cassette dans le compartiment.

Conduite directe

Ne pas fermer le compartiment à cassette. Le Akai GX-R99 est équipé d'un système de conduite directe. Lorsque l'une des touches de déplacement de bande (●, ▶, ◀, ▶▶, ■) est enfoncée, le compartiment à cassette se fermera automatiquement.



Let's Record (CRLP) Faisons un enregistrement (CRLP)

First follow all the steps on page 8, from the beginning through No. 7 and including AT BIAS. Then begin below.

Suivre tout d'abord toutes les étapes de la page 8, du début jusqu'au N°7, y compris la polarisation (AT BIAS). Continuer ensuite comme suit.

1 Stand by for recording

Depress the **CRLP** button.
The cassette holder will close.

The Auto Tape Tuning function will operate for the next few seconds, giving you optimum bias, equalization, and sensitivity, all adjusted automatically.

Then the Akai GX-R99 will go into the Rec. Standby mode.

The Auto Monitor will be set to Source so that you can see the volume levels of the music you want to record on you GX-R99's Bar Meters. Refer to pages 11 and 18.

In addition, the optimum volume level for recording with the tape inserted into the GX-R99 will also be set.

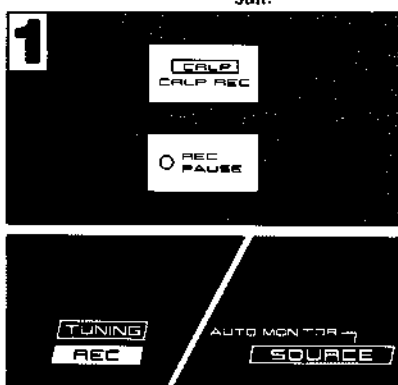

1 Attente pour enregistrement

Appuyer sur la touche CRLP.

Le compartiment à cassette se fermera. La fonction d'accord de bande automatique se mettra en action pendant les quelques secondes suivantes afin de régler automatiquement la polarisation, l'égalisation et la sensibilité optimum. Le Akai GX-R99 se mettra ensuite dans le mode attente enregistrement (Rec. Standby).

Le contrôleur automatique sera placé sur source de manière à pouvoir voir les niveaux de volume de la musique à enregistrer sur les indicateurs de barre de votre GX-R99. Se reporter à la page 11 et 18.

2 Set the Balance

Depress the small **LEVEL/BALANCE** button to select the **BALANCE** indicator. Then, depress the larger **LEVEL/BALANCE** button **L** or **R** to change the left and right channel balance.



Le GX-R99 régler également le niveau de volume optimum pour l'enregistrement avec la bande introduite dans le compartiment à cassette.

2 Appuyer sur la petite touche

LEVEL/BALANCE afin de choisir l'indicateur **BALANCE**. Appuyer ensuite sur la grande touche **LEVEL/BALANCE L** ou **R** pour faire varier l'équilibre des canaux droit et gauche.

3 Start recording

Depress the Play button (**◀** or **▶**) depending on the direction indicator display.

The Auto Monitor system will automatically set the Akai GX-R99 to monitor the tape as it is being recorded.

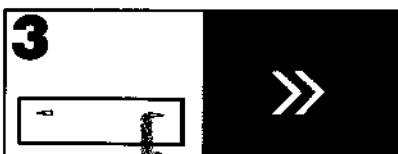

3 Démarrage

Appuyer sur la touche d'avance (**◀**) ou (**▶**) en fonction de l'affiche de l'indicateur de direction.

Le système de contrôleur automatique régler le Akai GX-R99 pour contrôler la bande lors de son enregistrement.

To stop recording

Depress the **STOP** (**■**) button.

On the Fader Button

Fade-in recording: Depress this button at the beginning of recording to gradually increase recording input levels from zero to the normal level.

Fade-out recording: Depress this button at the end of recording to gradually decrease recording input levels from the normal level to zero.

When this button is depressed during recording standby, the GX-R99 will automatically go into fade-in recording. When this button is depressed during recording, the GX-R99 will go into fade-out recording, then create 4 seconds of blank space, then go into recording standby mode.

Fade-in and fade-out recordings take place for approximately 4 seconds.

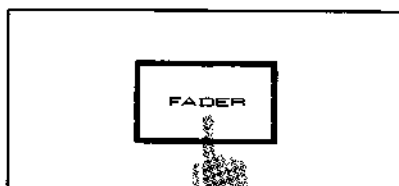

Lorsque cette touche est enfoncée lors de l'attente enregistrement, le GX-R99 se mettra automatiquement en début d'enregistrement par fondu. Lorsque cette touche est enfoncée lors de l'enregistrement, le GX-R99 se mettra en fin d'enregistrement par fondu, créera un espace vierge de 4 secondes et se placera en mode d'attente d'enregistrement.

Le début et la fin d'enregistrement par fondu durent approximativement 4 secondes.

Notes

- To stabilize the Akai GX-R99, the tape transport buttons will not function for approximately 4 seconds after the Akai GX-R99 is turned on.
- Do not depress a tape transport button when a cassette tape is not loaded.
- To open the cassette holder, depress the **EJECT** (▲) button. If you are not going to load another cassette tape, depress the **STOP** (■) button to close the cassette holder.

Remarques

- Pour stabiliser le Akai GX-R99, les touches de déplacement de bande ne fonctionneront pas pendant approximativement 4 secondes après la mise sous tension du Akai GX-R99.
- Ne pas appuyer sur une touches de déplacement de bande lorsqu'il n'y a pas de cassette dans le compartiment.
- Pour ouvrir le compartiment à cassette, appuyer sur la touche **EJECT** (▲). Si vous n'avez pas l'intention de placer une autre cassette dans le compartiment, appuyer sur la touche **STOP** (■) (arrêt) pour refermer le compartiment à cassette.

1 Stand by for recording

Depress the **REC/PAUSE** (●) button. The cassette holder will close.

The **Auto Tape Tuning** function will operate for the next few seconds, giving you optimum bias, equalization, and sensitivity, all adjusted automatically.

Then the Akai GX-R99 will go into the Rec. Standby mode.

The Auto Monitor will be set to Source so that you can see the volume levels of the music you want to record on your GX-R99's Bar Meters. Refer to pages 11 and 18.

2 Set the REC Input Levels

Depress the small **LEVEL/BALANCE** button to select the **VOLUME** indicator on the FL display. Then, depress the larger **LEVEL/BALANCE** button L or R to increase or decrease the volume respectively.

3 Set the Balance

Depress the small **LEVEL/BALANCE** button again to select the **BALANCE** indicator. Then, depress the larger **LEVEL/BALANCE** button L or R to change the left/right channel balance.

4 Start recording

Depress the **PLAY** button (◀ or ▶) depending on the direction indicator display.

The Auto Monitor system will automatically set the Akai GX-R99 to monitor the tape as it is being recorded.

5 To stop recording

Depress the **STOP** (■) button.

1 Attente pour l'enregistrement

Appuyer sur la touche enregistrement/pause (**REC/PAUSE** ●).

Le compartiment à cassette se fermera.

La fonction d'accord de bande automatique se mettra en action dans les secondes qui suivent, réglant automatiquement la polarisation, l'égalisation et la sensibilité optimum. Le Akai GX-R99 se placera ensuite dans le mode attente enregistrement (Rec. Standby). Le contrôleur automatique sera placé sur source de manière à pouvoir voir les niveaux de volume de la musique à enregistrer sur les indicateurs de barre du GX-R99. Se reporter à la page 11 et 18.

2 Régler les niveaux d'entrée enregistrement (REC)

Appuyer sur la petite touche niveau/équilibre (**LEVEL/BALANCE**) pour choisir l'indicateur **VOLUME** sur l'affichage FL. Appuyer ensuite sur la grande touche niveau/équilibre (**LEVEL/BALANCE**) L (gauche) ou R (droite) pour augmenter ou réduire les volumes respectifs.

3 Régler l'équilibre

Appuyer à nouveau sur la petite touche niveau/équilibre (**LEVEL/BALANCE**) pour choisir l'indicateur **BALANCE**. Appuyer ensuite sur la grande touche niveau/équilibre (**LEVEL/BALANCE**) L ou R pour faire varier l'équilibre des canaux gauche et droit.

4 Commencement de l'enregistrement

Appuyer sur la touche d'avance (◀) ou (▶) en fonction de l'affichage de l'indicateur de direction.

Le système de contrôle automatique (Auto Monitor) réglera automatiquement le Akai GX-R99 pour contrôler la bande lors de son enregistrement.

5 Pour arrêter l'enregistrement

Appuyer sur la touche (**STOP** ■).

Système de recherche d'espace vierge

La fonction de recherche d'espace vierge (**BLANK SEARCH**) du Akai GX-R99 retrouve rapidement une portion non enregistrée de la bande (d'au moins 3 minutes), produit un espace vierge de 4 secondes au début de la portion non enregistrée et s'arrête.

1. Appuyer sur la touche **BLANK SEARCH**.
2. Appuyer sur la touche **REC/PAUSE** (●) puis sur la touche d'avance (◀) ou (▶).

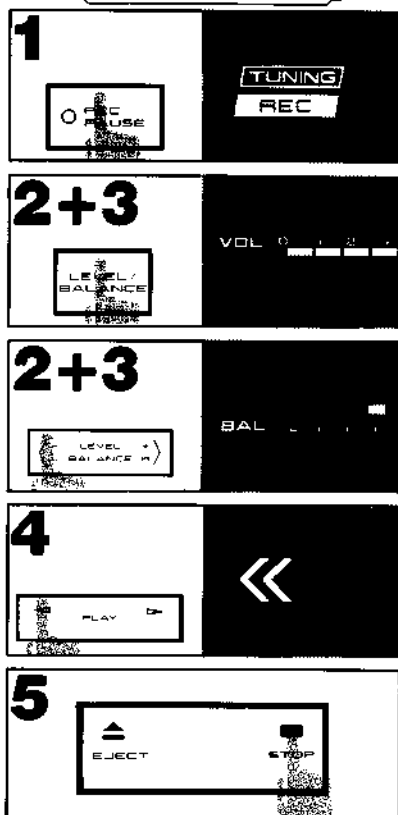
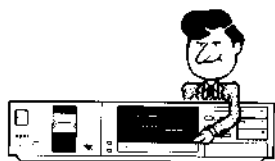

Blank Search System

The **BLANK SEARCH** feature of the Akai GX-R99, quickly locates an unrecorded portion of the tape, (at least 3 minutes worth) makes a 4-second blankspace at the beginning of the unrecorded portion and then stops.

1. Press the **BLANK SEARCH** Button.
2. Press **REC/PAUSE** (●) then forward (◀) or (▶) button, depending on the direction on the indicator display.

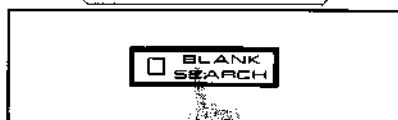
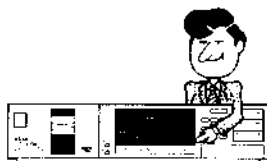

Notes on the Memory Function

The indicator lights on the memory buttons tell you two things.

1. They tell you which rec. level memory is in use.
2. They remind you that if you have changed the rec. level, you must turn off the memory button before depressing the **EJECT** or **POWER** buttons again. If you leave the memory button "active", a new rec. level will be set and the old one erased.

Remarque sur la fonction de mémoire

L'indicateur lumineux des touches de mémoire vous dit deux choses.

1. Il vous indique quelle mémoire de niveau d'enregistrement est utilisée.
2. Il vous rappelle que si vous avez modifié le niveau d'enregistrement, vous devez mettre hors circuit la touche de mémoire avant d'appuyer à nouveau sur la touche d'éjection (**EJECT**) ou d'alimentation (**POWER**). Si la touche de mémoire est "active", un nouveau niveau d'enregistrement sera réglé et l'ancien sera effacé.

Rec Level Memory

Up to 2 recording level settings can be memorized by using the **A** and **B** memory buttons. The memory can be used to instantly recall a non-standard setting, so you don't have to reset a level which you've already carefully set.



To Memorize:

1. Set the Rec. level of your choice.
2. Depress one of the Memory buttons to turn on. Confirm that the indicator light is lit.
3. Depress the **EJECT** button to memorize or depress the **POWER** button to memorize.

If you want to erase the memory:

Simply follow the procedure above using the same memory button again and memorizing the new rec. level right over the old one. The new level will be memorized and the old one erased.

If you want to return to a standard setting:

1. Turn off both memory buttons. Confirm that their indicator lights are off.
2. Depress **CRLP** to set a standard rec. level. Remember, headroom and other dynamic characteristics vary according to the type of tape used, i.e. metal, CrO₂, or normal. For best results, when re-recording a memorized rec. level, use the same type of tape as was used when the level was originally set.

Mémoire du niveau d'enregistrement

Jusqu'à 2 réglages de niveau d'enregistrement peuvent être mémorisés en utilisant les touches de mémoire **A** et **B**. La mémoire peut être utilisée pour un rappel instantané d'un réglage non standard, de sorte que vous n'avez pas besoin d'effectuer à nouveau un réglage que vous avez soigneusement déterminé.

Pour mémoriser:

1. Déterminez le niveau d'enregistrement de votre choix.
2. Appuyez sur l'une des touches de mémoire (**MEMORY**) pour la mettre en service. Vérifiez que l'indicateur est allumé.
3. Appuyez sur la touche d'éjection (**EJECT**) ou sur la touche d'alimentation pour mémoriser.

Si vous voulez effacer la mémoire:

Il vous suffit d'effectuer les opérations ci-dessus en utilisant à nouveau la même touche de mémoire et de mémoriser le nouveau niveau d'enregistrement sur l'ancien. Le nouveau niveau sera mémorisé et l'ancien sera effacé.

Si vous voulez revenir à un niveau standard:

1. Mettez hors circuit les deux touches de mémoire. Vérifiez que leurs indicateurs sont éteints.
2. Appuyez sur **CRLP** pour régler un niveau d'enregistrement standard. Souvenez-vous que l'extension et autres caractéristiques dynamiques varient conformément au type de bande utilisé, c'est-à-dire métal, CrO₂, ou normale. Pour obtenir de meilleurs résultats, lors du réenregistrement d'un niveau d'enregistrement mémorisé, utilisez le même type de bande que celui qui a été utilisé lorsque le niveau a été initialement réglé.

AT Bias and Auto Tape Tuning

The **Auto Tuning (AT) BIAS** control is used to adjust the amount of recording headroom according to the source signals. When set to **Std. (Standard)** position, the amount of recording bias is set to Akai's reference standard (see table page 26).



In addition, the bias can be set 10% above or below standard by depressing the **AT BIAS** selector prior to beginning **CRLP** or **Auto Tape Tuning** operations.

Over: The recording bias is increased by 10% and the **MML** characteristics are improved. The Maximum Modulation Frequency (**MML**) is the mid-frequency characteristic of a tape centered around 400 Hz.

Under: The recording bias is decreased by 10% and the **MOL** characteristics are improved. Maximum Output Level (**MOL**) is the high frequency characteristic of a tape centered around 8 kHz.

Note: Bias is added only during recording. This circuit has no function during playback.

Polarisation AT et syntonisation automatique de bande

La commande de polarisation de syntonisation automatique (**AT BIAS**) est utilisée pour ajuster la quantité d'extension d'enregistrement conformément aux signaux de source. Lorsqu'elle est réglée sur la position standard, la quantité de polarsation d'enregistrement est réglée sur la norme de référence Akai (voir tableau page 27).

De plus, la polarisation peut être réglée 10% au-dessus ou au-dessous de la norme en appuyant sur le sélecteur **AT BIAS** avant de commencer les opérations **CRLP** ou de syntonisation automatique de bande.

Au-dessus (OVER): La polarisation d'enregistrement est accrue de 10% et les caractéristiques **MML** sont améliorées. La fréquence maximum de modulation (**MML**) est la caractéristique de la fréquence moyenne d'une bande centrée autour de 400 Hz.

Au-dessous (UNDER): La polarisation d'enregistrement est diminuée de 10% et les caractéristiques **MOL** sont améliorées. Le niveau maximum de sortie (**MOL**) est la caractéristique de haute fréquence d'une bande centrée autour de 8 kHz.

Remarque: La polarisation n'est ajoutée que pendant l'enregistrement. Ce circuit n'a aucune fonction pendant la reproduction.

Spectrum and MOL Displays

The **Spectrum Meter** displays the recording input level for two frequencies which are representative of the basic response curve of most tapes. The upper bar of the meter (**M. Low**) measures frequency response at around 400 Hz. The lower bar of the meter (**High**) measures frequency response at around 8 kHz.

In conjunction with the **MOL** display, you can visually monitor whether these response levels are within the **MOL** and **MML** characteristics of any particular tape.

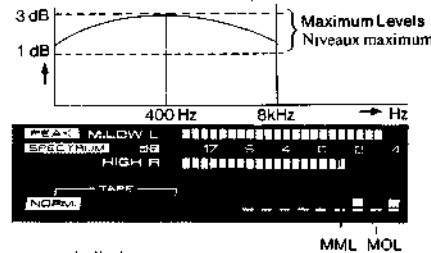

When **CRLP** is depressed, the **MOL** characteristics of the tape in use are set and displayed according to the bias level set with the **AT BIAS** selector. These characteristics are displayed in the form of two markers (one for **MML** and one for **MOL**) on the **MOL** display at levels corresponding to the dB level of the **Spectrum** meter above.

Note: With some tapes, the **MOL** and **MML** level will be the same. In that case, only one marker will appear on the **MOL** display.

Affichages spectre et MOL

L'indicateur du spectre affiche le niveau d'entrée d'enregistrement pour deux fréquences qui sont représentatives de la courbe de réponse de base de la plupart des bandes. La barre supérieure de l'indicateur (**M. Low**) mesure la réponse en fréquence à environ 400 Hz. La barre inférieure de l'indicateur (**High**) mesure la réponse en fréquence à environ 8 kHz.

En l'utilisant en conjonction avec l'affichage **MOL**, vous pouvez contrôler visuellement si ces niveaux de réponse sont à l'intérieur des caractéristiques **MOL** et **MML** d'une bande particulière.

Lorsque la touche **CRLP** est enclenchée, les caractéristiques **MOL** de la bande utilisée sont réglées et affichées conformément au niveau de polarisation réglé avec le sélecteur **AT BIAS**. Ces caractéristiques sont affichées sous la forme de deux repères (un pour le **MML** et un pour le **MOL**) sur l'affichage **MOL** à des niveaux correspondant au niveau dB de l'indicateur de spectre ci-dessus.

Remarque: Avec certaines bandes, les niveaux **MOL** et **MML** seront les mêmes. Un seul repère apparaîtra sur l'affichage **MOL** dans ce cas.

CRPL

The **Computer Recording Level Processing system**, uses a computer controlled attenuator which sets the optimum recording volume level for the greatest dynamic range possible.

With **CRPL**, the delicate job of setting the maximum recording level without crossing the point of dramatically increased distortion, is accomplished with the touch of a button.

How CRPL works.

The information contained on the first 10 seconds of tape is all that is needed for the **CRPL** circuit to adjust the volume to the **MOL** characteristics of any tape. But **CRPL** doesn't stop there. It continues to monitor the music and adjust the volume if the **MML** or **MOL** levels are exceeded anytime during recording.

CRPL

Le système de traitement par ordinateur du niveau d'enregistrement (**CRPL**) utilise un atténuateur commandé par ordinateur qui règle le niveau de volume d'enregistrement optimum afin de donner la gamme dynamique la plus étendue. Avec le **CRPL**, la tâche délicate de régler le niveau maximum d'enregistrement sans franchir le point où la distorsion est excessivement accrue, est accomplie par simple pression d'une touche.

Comment fonctionne le CRPL

Les informations contenues sur les 10 premières secondes d'une bande sont tout ce qui est nécessaire pour que le circuit **CRPL** ajuste le volume aux caractéristiques du **MOL** (niveau maximum de sortie) d'une bande. Mais le **CRPL** ne s'arrête pas là. Il continue à contrôler la musique et à régler le volume si les niveaux **MML** (fréquence maximum de modulation) ou **MOL** sont dépassés pendant l'enregistrement.



A little know-how goes a long way Un peu de savoir-faire fait tout la différence

To record from playback

Use this method to record an unrecorded portion of tape. You can also use this method to find and record over a recorded portion of tape.

1. Start Playback of source
2. Depress **REC/PAUSE** (●) button and adjust **Rec. Level** of the GX-R99.
3. When you come to the point where you want to start recording, depress the **PLAY** button, (◀ or ▶) depending on the direction indicator display (« or »).

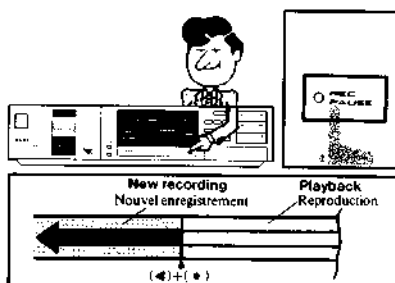

Pour enregistrer à partir de reproduction

Utilisez cette méthode pour enregistrer une portion non enregistrée d'une bande. Vous pouvez également utiliser cette méthode pour trouver et ré-enregistrer sur une portion enregistrée de la bande.

1. Démarrez la reproduction de la source.
2. Appuyez sur la touche d'enregistrement/pause (**REC/PAUSE** ●) et réglez le niveau d'enregistrement du GX-R99.
3. Lorsque vous arrivez au point où vous voulez commencer l'enregistrement, appuyez sur la touche de lecture (◀ ou ▶) selon l'affichage de l'indicateur de sens (« ou »).

To create blank spaces between selections

You can automatically create 4 seconds of blank space with the **AUTO MUTE** button.

1. Start recording.
2. Depress the **AUTO MUTE** button at the end of a selection.
 - * The Akai GX-R99 will create 4 seconds of blank space and then stand by for recording.

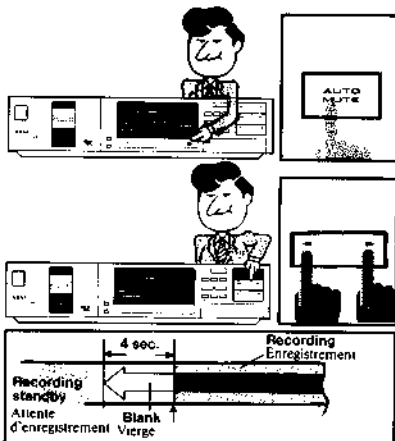

Pour créer des intervalles vierges entre les sélections

Vous pouvez créer automatiquement 4 secondes d'intervalle vierge avec la touche de sourdine automatique (**AUTO MUTE**).

1. Démarrez l'enregistrement.
2. Appuyez sur la touche de sourdine automatique (**AUTO MUTE**) à la fin de la sélection.
 - * Le GX-R99 Akai créera 4 secondes d'intervalle vierge, puis se mettra en attente d'enregistrement.

To re-start recording

3. Depress the play (◀ or ▶) button.

Pour redémarrer l'enregistrement

3. Appuyez sur la touche de lecture (◀ ou ▶).

To temporarily stop recording

You can temporarily stop recording with the **REC/PAUSE** (●) button.

1. Start recording.
2. Depress the **REC/PAUSE** (●) button when you want to stop recording.

To re-start recording

3. Depress the play (◀ or ▶) button depending on the direction indicator display (« or »).

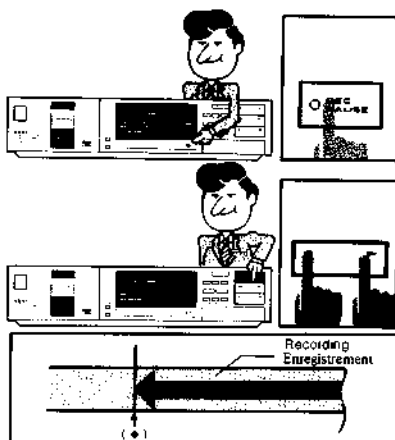

Pour arrêter provisoirement l'enregistrement

Vous pouvez arrêter provisoirement l'enregistrement avec la touche d'enregistrement/pause (**REC/PAUSE** ●).

1. Démarrez l'enregistrement.
2. Appuyez sur la touche d'enregistrement/pause (**REC/PAUSE** ●) lorsque vous voulez arrêter l'enregistrement.

Pour redémarrer l'enregistrement

3. Appuyez sur la touche de défilement (◀ ou ▶) selon l'affichage de l'indicateur de sens (« ou »).

Notes on recording cancel

- In order for the recording cancel to function properly, there must be 4 seconds of blank space at the beginning of the selection.
- In some recordings like classical, there may be breaks of 4 seconds or more during a selection or there may be some parts where the sound is very low for 4 seconds or more. Such sections may be detected as blank spaces during recording cancel. Check to see that you are at the beginning of the selection before re-recording.

Remarques sur l'annulation d'enregistrement

- Afin que la fonction d'annulation d'enregistrement fonctionne correctement, il doit y avoir 4 secondes d'intervalle vierge au début de la sélection.
- Dans certains enregistrements, comme ceux de musique classique, il peut y avoir des coupures de 4 secondes ou plus pendant une sélection, ou il peut y avoir des parties où le son est très faible pendant 4 secondes ou plus. Ces sections peuvent être détectées comme espaces vierges pendant l'annulation d'enregistrement. Vérifiez que vous êtes bien au début de la sélection avant de réenregistrer.

To cancel the just recorded section

When you want to cancel the just recorded section, depress the **REC CANCEL** button while the tape deck is in the recording mode. The GX-R99 will rewind the tape to the beginning of the just recorded section and then stand by for recording after creating 4 seconds of blank space.

Start recording.

1. When you want to cancel the recording, depress the **REC CANCEL** button.

To re-start recording

2. Depress the play button (◀ or ▶) depending on the direction indicator display (◀ or ▶).

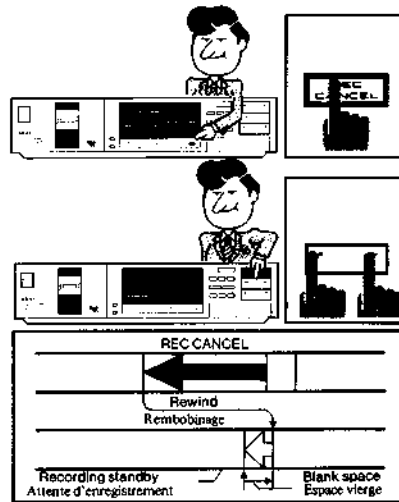

Pour annuler la section qui vient juste d'être enregistrée

Lorsque vous voulez annuler la section qui vient juste d'être enregistrée, appuyez sur la touche d'annulation d'enregistrement (**REC CANCEL**) pendant que la bande est sur le mode d'enregistrement.

Le GX-R99 Akai rembobinera la bande jusqu'au début de la section qui vient juste d'être enregistrée puis se mettra en attente d'enregistrement après avoir créé 4 secondes d'intervalle vierge.

Démarrez l'enregistrement.

1. Lorsque vous voulez annuler l'enregistrement, appuyez sur la touche d'annulation d'enregistrement (**REC CANCEL**).

Pour redémarrer l'enregistrement

2. Appuyez sur la touche de lecture (◀ ou ▶) selon l'affichage de l'indicateur de sens (◀ ou ▶).

The Digital Counter

The 3-way Digital Counter and tape length selector, allow for great flexibility in recording and indexing your tapes.

Elapsed time counter: Tells you in min. and sec. how much time has elapsed since the beginning of playback or recording.

Time remaining counter (and tape length selector): Tells you how much time is remaining on the unplayed portion of tape.

Tape counter: Allows you to index recordings.

How to use: Depress the **TAPE** button until the proper tape length appears in place of the tape counter on the FL indicator (LC46, C46, C60 or C90).

Depress the **MODE** button until the counter you wish to use appears (**ELAPSED, REMAIN** or **COUNTER**).

Depress the **RESET** button to return to the "0000" setting. Depress any tape transport button to begin counting.

Counter Notes:

- When the GX-R99 is turned on or off, the tape indicator will automatically return to C90. Please check the indicator and adjust for your tape.
- The tape counters are intended as a guide only and are not an exact measurement of real time.
- The Time Remaining counter cannot be reset to "0000" with the reset button since the Time Remaining mode automatically senses the amount of tape remaining whenever the play button is depressed. The Time Remaining display returns to "0000" only when the tape cassette is removed.

Compteur numérique

Le compteur numérique à 3 indications et le sélecteur de longueur de bande donnent une grande flexibilité pour l'enregistrement et l'indexage des bandes.

Compteur de temps écoulé: Vous indique en minutes et secondes combien de temps s'est écoulé depuis le début de la reproduction ou de l'enregistrement.

Compteur de temps restant (et sélecteur de longueur de bande): Vous indique quel est le temps restant sur la portion non reproduite de la bande.

Compteur de bande: Vous permet d'indexer des enregistrements.

Utilisation: Appuyez sur la touche de bande jusqu'à ce que la longueur correcte de bande apparaisse à la place du compteur de bande sur l'indicateur fluorescent (LC46, C46, C60 or C90).

Appuyez sur la touche de mode jusqu'à ce que le compteur que vous désirez utiliser apparaisse (temps écoulé, temps restant ou compteur).

Appuyez sur la touche de réinitialisation pour remettre à "0000" le compteur. Appuyez sur n'importe quelle touche de transport de bande pour démarrer le compteur.

Remarques sur le compteur:

- Lorsque le GX-R99 est mis sous tension et hors circuit, l'indicateur de bande retournera automatiquement à C90. Veuillez vérifier l'indicateur et le régler pour la bande utilisée.
- Les compteurs de bande ne sont conçus qu'en tant que guides et ils ne sont pas une mesure exacte du temps réel.
- Le compteur de temps restant ne peut pas être réinitialisé à "0000" avec la touche de réinitialisation puisque le mode de temps restant détecte automatiquement la quantité de bande restante lorsque la touche de lecture est enfoncée. L'affichage du temps restant ne retourne à "0000" que lorsque la bande cassette est déchargée.

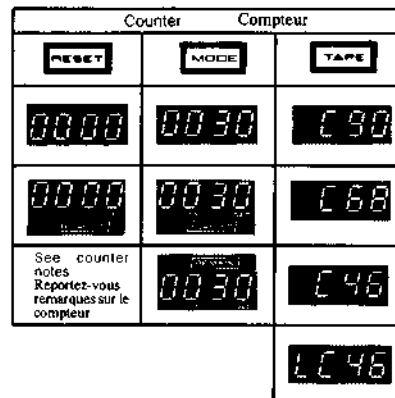



Let's play back the tape Pour reproduire une bande

Get ready

1. The **TIMER START** switch is set to **OFF** (OFF).
2. The **OUTPUT/PHONES** control is set to around 5.
3. Depress the **POWER** switch to turn on the Akai GX-R99.

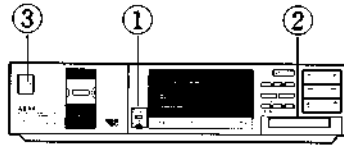

Préparez-vous

1. Réglez le commutateur de démarrage minuterie (**TIMER START**) sur arrêt (**OFF**).
2. Réglez la commande de sortie/casque (**OUTPUT/PHONES**) vers 5.
3. Appuyez sur le commutateur d'alimentation (**POWER**) pour mettre sous tension le GX-R99.

Set the tape length by depressing the **TAPE** button repeatedly (C90, C60, C46, LC46). Refer to page 13.

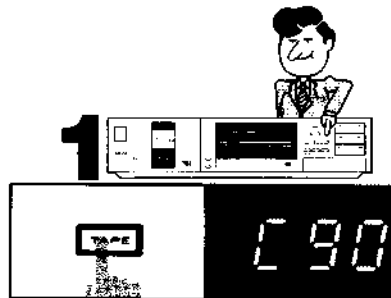

Réglez la longueur de la bande en appuyant de façon répétée sur la touche bande (**TAPE**) (C90, C60, C46, LC46). Reportez-vous page 10.

Select the counter by depressing the **MODE** button repeatedly. Set the counter to "0000" by depressing the **RESET** button. Refer to page 13.

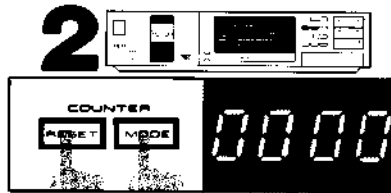

Sélectionnez le compteur en appuyant de façon répétée sur la touche de **MODE**. Mettez le compteur à "0000" en appuyant sur la touche de réinitialisation (**RESET**). Reportez-vous page 10.

Depress the **REV SELECT** button to change from single side to two sided recording.
Note: The **REV SELECT** is automatically set to continuous play when the GX-R99 is first turned on.

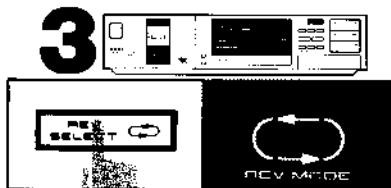

Appuyez sur la touche du sélecteur d'inversion (**REV SELECT**) pour passer d'un enregistrement une face à un enregistrement deux faces.

Remarque: Le sélecteur d'inversion (**REV SELECT**) est automatiquement réglé sur continu lors de la première mise sous tension du GX-R99.

Set the **DOLBY NR ON/OFF** switch, and select the B or C type. Refer to page 19.
Set the **MPX FILTER** switch. Refer to page 21.

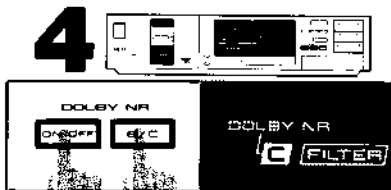

Réglez le commutateur marche/arrêt (**ON/OFF**) **DOLBY NR**, et sélectionnez le type B ou C. Reportez-vous page 16.

Réglez le commutateur filtre MPX (**MPX FILTER**). Reportez-vous page 18.

Depress the **EJECT** (▲) button and load a cassette tape.

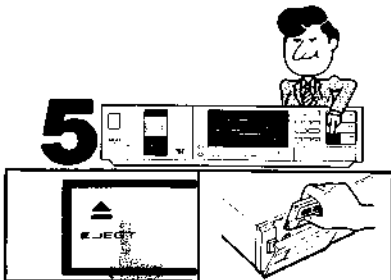

Appuyez sur la touche d'éjection (**EJECT** ▲) et chargez une bande cassette.



Convenient playback features using the auto system

Possibilités de lecture pratiques à l'aide du système auto

Intro scan

The Akai GX-R99 will play back the beginning of each selection for 10 seconds.

1. Depress the play (▶) and fast forward (⏩) buttons simultaneously. The GX-R99 will fast forward the tape to the beginning of each selection, and play the first 10 seconds of music. This allows you to quickly identify the selection you want to playback.
2. When you come to the selection you want to listen to, depress the play (▶) button to continue with normal play.

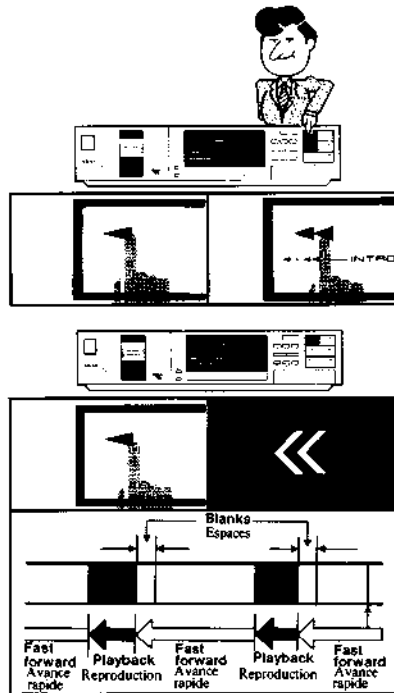

Balayage d'introduction

Le GX-R99 Akai reproduira le début de chaque sélection pendant 10 secondes.

1. Presser simultanément les touches reproduction (▶) et avance rapide (⏩). Le GX-R99 avancera rapidement la bande au commencement de chaque sélection, et reproduira les 10 premières secondes de musique. Ceci vous permet d'identifier rapidement la sélection que vous désirez reproduire.
2. Lorsque vous arrivez à la sélection que vous désirez écouter, appuyez sur la touche de lecture (▶) pour reprendre la lecture normale.

Instant Program Locating System (IPLS)

The Akai GX-R99 will find the beginning of and playback the current or next selection.

1. Start playback
2. Depress the **IPLS** button.

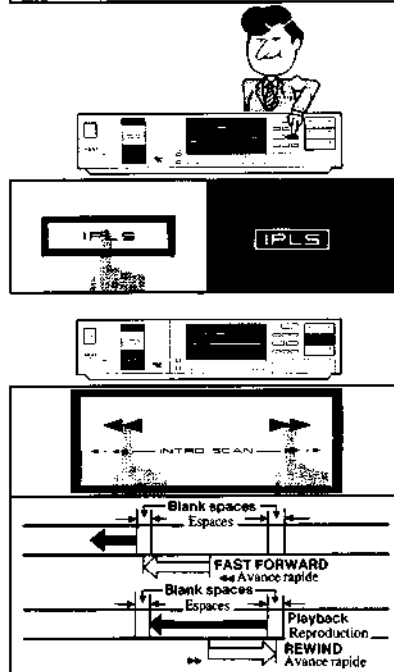

Depress the fast forward (⏩) button to playback from the beginning of the next selection.

Depress the rewind (⏪) button to playback from the beginning of the current selection.

Note on Forward and Rewind

With Auto Reverse Cassette Decks, the directions 'Forward' and 'Rewind' will change depending on which track is being played at the time—since the tape travel and heads can be reversed instantly for playback in either direction. However, the direction in which the music is actually played at any given point is considered forward and it's opposite (non-playback direction) is rewind.

Système de localisation instantanée du programme (IPLS)

Le GX-R99 Akai trouvera et reproduira le début de la sélection en cours ou de la sélection suivante.

1. Démarrez la reproduction.
2. Appuyez sur la touche **IPLS**.

Appuyez sur la touche d'avance rapide (⏩) pour reproduire depuis le début de la sélection suivante.

Appuyez sur la touche de rembobinage (⏪) pour reproduire depuis le début de la sélection en cours.

Note sur l'avance et le rembobinage

Avec les magnétocassettes à inversion automatique, les directions "Avance" (Forward) et "Rembobinage" (Rewind) changeront selon la piste en cours de reproduction à ce moment-là—puisque le défilement de bande et les têtes peuvent être inversés instantanément pour une reproduction dans une autre direction. Cependant, la direction dans laquelle la musique est actuellement reproduite à n'importe quel point donné est considérée comme l'avance tandis que son opposé (direction non reproduite) est le rembobinage.

Notes

- To stabilize the Akai GX-R99, the tape transport buttons will not function for approximately 5 seconds after the Akai GX-R99 is turned on.
- Do not depress a tape transport button when a cassette tape is not loaded.
- To open the cassette holder, depress the **EJECT** (▲) button. If you are not going to load another cassette tape, depress the **STOP** (■) button to close the cassette holder.

Remarques

- Pour stabiliser le GX-R99 Akai, les touches de transport de la bande ne fonctionneront pas pendant approximativement 5 secondes après que le GX-R99 Akai est mis sous tension.
- N'appuyez pas sur une touche de transport de la bande lorsqu'aucune bande cassette n'est chargée.
- Pour ouvrir le compartiment de cassette, appuyez sur la touche d'éjection (**EJECT** ▲). Lorsqu'aucune bande cassette ne doit être chargée, appuyez sur la touche d'arrêt (**STOP** ■) pour fermer le compartiment de cassette.

Start playback

Depress the play (◀ or ▶) button.

- * The direct lead-in system will close the cassette holder.



Démarrer la reproduction

Appuyez sur la touche de lecture (◀ ou ▶).

- * Le système d'introduction directe fermera le compartiment de cassette.

To adjust the output level

Use the **OUTPUT/PHONES** control. Refer to page 21.

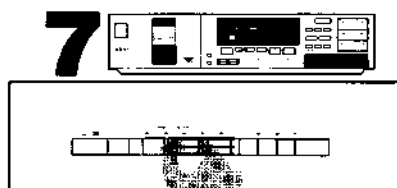

Pour ajuster le niveau de sortie

Utilisez la commande sortie/casque (**OUTPUT/PHONES**). Reportez-vous page 18.

To stop playback

Depress the **STOP** (■) button, or go directly to fast forward, rewind or **EJECT**.

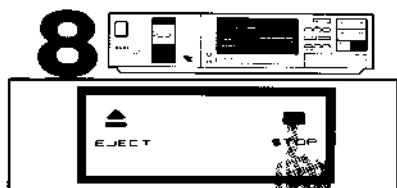

Pour arrêter la reproduction

Appuyez sur la touche d'arrêt (**STOP** ■) ou passez directement en avance rapide, rembobinage ou éjection (**EJECT** ▲).

To rewind the tape

If the direction indicator display shows the playback direction as (»), depress the (◀◀) button to rewind.

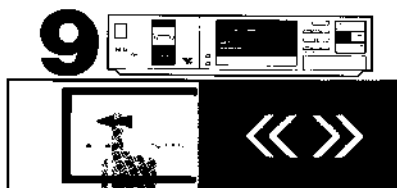

Pour rembobiner la bande

Si l'affichage de l'indicateur de sens montre le sens de lecture comme (»), appuyez sur la touche (◀◀) pour rembobiner.

To fast forward the tape

If the direction indicator display shows the playback direction as (»), depress the (▶▶) button to fast forward.

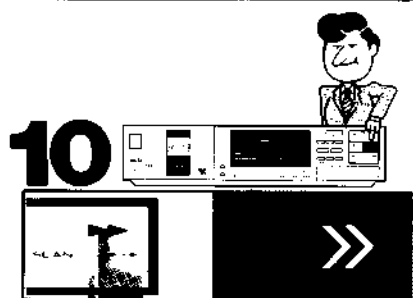

Pour avancer rapidement la bande

Si l'affichage de l'indicateur de sens montre le sens de lecture comme (»), appuyez sur la touche (▶▶) pour faire avancer rapidement la bande.



What you should know . . . Ce qu'il faut savoir . . .

How to set the correct recording input levels

The basic way

Adjust the **REC LEVEL** controls so that the maximum indications on the **VU** bar meter does not go beyond 0 dB.

To enjoy good playback

To enjoy good playback, you must set the recording input levels correctly. The recording input levels should be set as high as possible. However, if the levels are too high, distortion will be added and if they are too low, tape noise such as tape hiss will become noticeable. You must set the recording input levels so that the maximum levels of the music source just fit the limit of the tape's characteristics (i.e. saturation level). Tape characteristics differ according to the type of tape (metal, chrome and normal). Therefore, you should set the recording input levels according to the type of tape you use.

How to set the recording input levels according to the type of tape

Cassette tapes can be widely grouped into 3 types: metal position, chrome (CrO₂) position and normal position. Set the recording input levels accordingly.

These indications are the recording input levels that the music source's maximum levels should reach. You should use these indications as a reference and set the recording input levels so that you do not notice distortions.

Set the recording input levels according to the music source

The recording input levels should be set according to the type of tape used, but you should also set them according to the music source. Compared with music containing mostly vocals, music containing mostly strings, pipe organs, pianos, percussions, etc. have signals in the high levels which are distributed widely over the frequency range, even up to the high frequencies. Therefore, if the recording input levels of such a music source are set at the same levels as that of the vocal music, the high frequencies will be beyond the tape's saturation level and distortion will result. Thus, you should also set the recording input levels according to the music source.

You should compare the playback directly against the music source

The best way to judge whether you have set the recording input levels correctly is to compare the playback with the music source. For this purpose, the Akai GX-R99 is equipped with the auto monitor system. Use the Auto Monitor button to listen to either tape or playback source. This button will also switch the **PEAK/VU** meter to monitor either tape or source for visual confirmation of recording levels.

The PEAK/VU Meter

The peak meter shows the peak (maximum) level of input signal and the **VU** meter shows the average value of input signal. As the listening characteristics of man are close to that of an average value of sound volume, many audio components such as mixing amplifier, tape deck, broadcast equipment use **VU** meters. However, the peak level of a signal can not be detected by a **VU** meter. Thus if a signal has a peak level of more than 8 dB, and it is recorded only using a **VU** meter, distortion will result. This unit is equipped with a **PEAK/VU** selector so that the bar meter can become a peak or a **VU** meter at a touch of a button. By monitoring the peak level, the dynamic range of recording tape can be fully brought out.

Comment régler les niveaux corrects d'entrée d'enregistrement

Méthode de base

Réglez les commandes de niveau d'enregistrement (**REC LEVEL**) de sorte que les indications maximum sur l'indicateur barre fluorescent ne passent pas 0 dB.

Pour apprécier une bonne reproduction

Les niveaux d'entrée d'enregistrement doivent être correctement réglés pour obtenir une bonne reproduction. Les niveaux d'entrée d'enregistrement doivent être aussi hauts que possible. Cependant, si les niveaux sont trop élevés, une distorsion sera ajoutée, et s'ils sont trop faibles, le bruit de bande tel que le sifflement deviendra perceptible. Vous devez régler les niveaux d'entrée d'enregistrement de sorte que les niveaux maximum de la source musicale s'insèrent exactement dans les limites des caractéristiques de la bande (c'est-à-dire le niveau de saturation). Les caractéristiques diffèrent selon le type de bande (métal, chrome et normale). Il faut donc régler les niveaux d'entrée d'enregistrement en fonction du type de bande utilisée.

Comment régler les niveaux d'entrée d'enregistrement en fonction du type de bande

Les bandes cassettes peuvent être divisées en 3 types principaux: à position métal, à position chrome (CrO₂) à position normale. Réglez les niveaux d'entrée d'enregistrement en fonction de leur type.

Ces indications sont les niveaux d'entrée d'enregistrement que les niveaux maximum de la source musicale devraient atteindre. Ces indications doivent être utilisées comme référence et les niveaux d'entrée d'enregistrement doivent être réglés de sorte qu'aucune distorsion ne soit perceptible.

VU meter		VU-mètre	
Type	Type	Setting	Réglage
Normal position	Position normale	Around 0 dB	Autour de 0 dB
Chrome (CrO ₂) position	Position (CrO ₂) chrome	0-2 dB	0 à 2 dB
Metal position	Position métal	2-5 dB	2 à 5 dB
Peak meter		Indicateur de crête	
Type	Type	Setting	Réglage
Normal position	Position normale	4-8 dB	4 à 8 dB
Chrome (CrO ₂) position	Position chrome	6-8 dB	6 à 8 dB
Metal position	Position métal	8-10 dB	8 à 10 dB

Réglez les niveaux d'entrée d'enregistrement en fonction de la source musicale

Les niveaux d'entrée d'enregistrement doivent être réglés en fonction du type de bande utilisée, mais ils doivent également être réglés en fonction de la source musicale. Comparé à la musique principalement vocale, la musique composée principalement d'instruments à cordes, à percussion, de pianos ou d'orgues, etc. a des signaux de haut niveau qui sont répartis sur toute la gamme de fréquence, même jusqu'aux hautes fréquences. Donc, si les niveaux d'entrée d'enregistrement de ce type de musique sont réglés aux mêmes niveaux que ceux de la musique vocale, les hautes fréquences seront au-delà du niveau de saturation de la bande et il en résultera une distorsion. Les niveaux d'entrée d'enregistrement doivent donc également être réglés en fonction de la source musicale.

Vous devez comparer la reproduction directement à la source musicale

La meilleure manière de juger si les niveaux d'entrée d'enregistrement ont été correctement réglés est de comparer la reproduction à la source musicale. Dans ce but, le GX-R99 est équipé d'un système de contrôle automatique. Utilisez le commutateur de contrôle automatique pour écouter soit la bande, soit la source de reproduction. Ce commutateur peut également modifier l'indicateur crête/VU afin de contrôler soit la bande soit la source pour une vérification visuelle des niveaux d'enregistrement.

Indicateur crête/VU (PEAK/VU)

L'indicateur crête indique le niveau de crête (maximum) du signal d'entrée et l'indicateur **VU** indique la valeur moyenne du signal d'entrée. Les caractéristiques d'écoute de l'homme étant proches de celles d'une valeur moyenne de volume sonore, de nombreux équipements audio comme les amplificateurs de mixage, les platines, les appareils d'enregistrement, utilisent des **VU**-mètres. Le niveau de crête d'un signal ne peut cependant pas être détecté par un **VU**-mètre. Ainsi, si un signal a un niveau de crête de plus de 8 dB, et qu'il est enregistré en n'utilisant qu'un **VU**-mètre, il en résultera des distorsions. Cette unité est équipée d'un sélecteur crête/VU (**PEAK/VU**) de sorte que l'indicateur barre peut devenir un indicateur de crête ou un **VU**-mètre par pression d'une touche. En contrôlant le niveau de crête, la gamme dynamique de la bande d'enregistrement peut être mise en relief.

Notes on intro scan IPLS

- Intro scan and IPLS operate when the music signal is below a specific level for a required length of time. Therefore, in music such as classical and live recording, where some parts may contain low signals for the required length of time (more than 4 seconds), intro scan and IPLS might not function properly.
- With some live recordings, there may be applause between the selections. Such sections will not be detected as blank spaces.

Remarques sur le balayage d'introduction et l'IPLS

- Le balayage d'introduction et l'IPLS fonctionnent lorsqu'un signal musical est au-dessous d'un niveau spécifique pendant une durée requise. Dans certains morceaux tels que musique classique et concerts sur scène, dans lesquels certains passages peuvent contenir des signaux faibles pendant la durée requise (plus de 4 secondes), le balayage d'introduction et l'IPLS peuvent donc ne pas fonctionner correctement.
- Dans certains enregistrements de concerts sur scène, il peut y avoir des applaudissements entre les sélections. Ces sections ne seront pas détectées comme espaces vierges.

Quick Memory Search System

QMSS can be used to quickly rewind the tape to any preset point in the tape that you choose.

Play Back

1. Find the point on the tape you wish to return to.
2. Press the **MODE** button to find the tape counter mode.

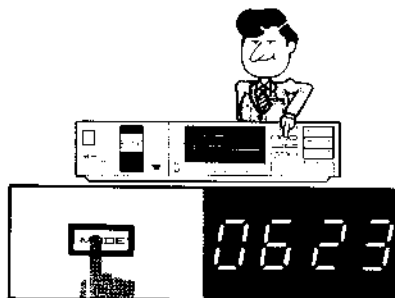

3. Press the **RESET** button to set the counter to "0000".

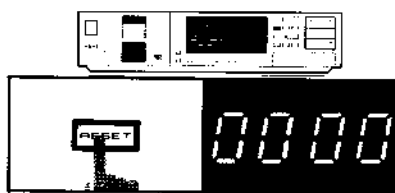

4. Begin playback. Play the tape up to any point.

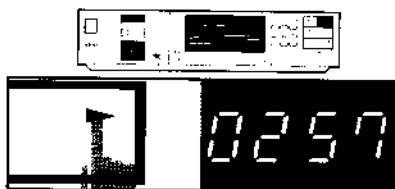

5. To go back to "0000", just press the **QMSS** button. The tape will automatically rewind to "0000" and then begin playback again.

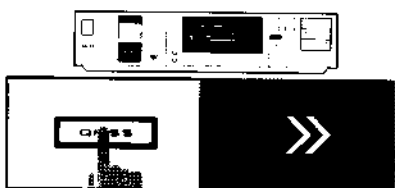

Recording

1. **RESET** the tape counter to "0000" at any point you wish to return to.
2. **AFTER RECORDING**, press the **QMSS** button. The tape will rewind to "0000" and begin playback of the just recorded selection.

Note on Quick Memory Search System

The tape will be rewound to near the tape counter reading of "9999" and not to "0000". This is so that you will be able to hear the music from "0000".

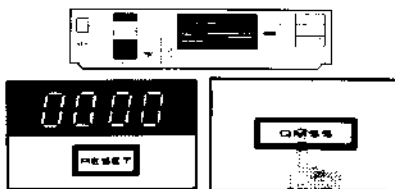

Système de recherche rapide à mémoire (QMSS)

Le QMSS peut être utilisé pour rembobiner rapidement la bande jusqu'à n'importe quel point présélectionné sur la bande.

Reproduction

1. Trouvez le point sur la bande auquel vous voulez retourner.
2. Appuyez sur la touche de **MODE** jusqu'à ce que le mode de compteur de bande soit sélectionné.

3. Appuyez sur la touche de réinitialisation (**RESET**) pour mettre à "0000" le compteur de bande.

4. Démarrer la reproduction. Reproduisez la bande jusqu'à n'importe quel point.

5. Pour retourner à "0000", appuyez simplement sur la touche **QMSS**. La bande sera automatiquement rembobinée jusqu'à l'indication "0000" du compteur et la reproduction reprendra.

Enregistrement

1. Réinitialisez le compteur de bande à "0000" à n'importe quel point auquel vous désirez retourner.
2. Après l'enregistrement, appuyez sur la touche **QMSS**. La bande se rembobinera jusqu'à l'indication "0000" du compteur et la reproduction de la sélection qui vient juste d'être enregistrée commencera.

Remarque sur le système de recherche rapide à mémoire

La bande sera rembobinée jusqu'à près de l'indication "9999" du compteur et non pas "0000". Ceci pour vous permettre d'écouter la musique à partir de "0000".



...and then some ...et autres

Quick reverse

Stereo cassette decks employ a 4-track recording/playback system. The first half of the stereophonic recording or playback takes place on tracks 1 and 2 (side A), and the second half takes place on tracks 3 and 4 (side B). In a conventional cassette deck, you must turn over the cassette tape if you want to record or play back on a different side. The Akai GX-R99 is equipped with the quick reverse system. The tape travel direction changes automatically at the end of the tape. Therefore, there is no need to turn over the cassette tape yourself.

Note:

You can also manually change the tape travel direction by depressing the forward or reverse button without first pressing stop. The direction indicators will show the tape travel direction (« or »).

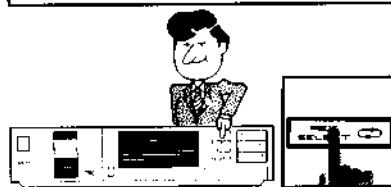
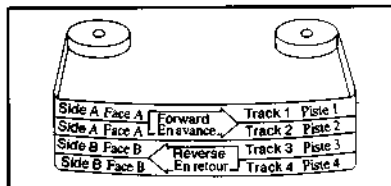

Inversion rapide

Les magnétocassettes stéréo incorporent un système d'enregistrement/reproduction à 4 pistes. La première moitié de l'enregistrement ou de la reproduction stéréophonique s'effectue sur les pistes 1 et 2 (face A), et la seconde moitié s'effectue sur les pistes 3 et 4 (face B). Avec un magnétocassette conventionnel, vous devez retourner la bande cassette si vous voulez enregistrer ou reproduire sur l'autre face. Le GX-R99 Akai est équipé d'un système d'inversion rapide. Le sens de défilement de la bande change automatiquement à la fin de la bande. Vous n'avez donc pas besoin de retourner vous-même la bande cassette.

Remarque:

Vous pouvez également changer le sens de défilement de la bande en appuyant sur la touche d'avance ou de retour sans avoir à appuyer sur la touche d'arrêt. Les indicateurs de sens indiquent le sens de défilement de la bande («ou»).

Attention!

- For quick reverse operation, always use a tape with very clear leader tape sections.
- When a prerecorded tape is used for one-cycle (forward to reverse) recording, the first one second of the reverse side of the tape will not be erased. Please manually erase this section.
- During quick reverse operation, no recording will be made for 0.8 second.
- The **REV SELECTOR** has no effect during intro scan and blank search operations.

Attention!

- Pour une utilisation de l'inversion rapide, utilisez toujours une bande ayant des sections de bande amorce très claires.
- Lorsqu'une bande pré-enregistrée est utilisée pour un enregistrement un cycle (d'avance en retour), la première seconde de l'autre face de la bande ne sera pas effacée. Effacez manuellement cette section.
- Pendant la fonction d'inversion rapide, aucun enregistrement ne s'effectuera pendant 0,8 seconde.
- Le sélecteur d'inversion (**REV SELECT**) n'a pas d'effet pendant les fonctions de balayage d'introduction et de recherche des blancs sonores.

The microprocessor "brain" and infrared "eye" of the Akai GX-R99 allow for maximum convenience in your recording and playback operations.

Playback

1. Press the Reverse selector (**REV SELECT**) to set the mode.
- A:** Indicates the tape can travel in only one direction depending on which button is depressed: either (◀) or (▶).
- B:** Indicates one full cycle. The tape will play to the end of side 1, reverse, play side 2 and then stop.
- C:** Indicates infinite playback. The tape will continue to reverse and playback both sides until you change the function.

Record

1. Press the **REC/PAUSE** (●) button to standby for recording
 2. Press the Rev. Selector to set the mode.
- A:** Same as above only in recording mode.
- B:** In this mode, the Akai GX-R99 will record one complete cycle (side A and side B) then go into continuous playback of the just recorded tape.

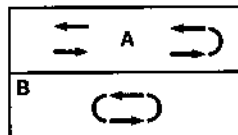
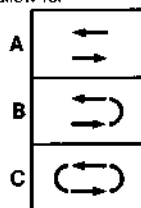

Auto Tape Tuning

The Auto Tape Tuning function which takes place automatically whenever the Rec. button is depressed, produces the maximum performance from any type of tape. The GX-R99 sets optimum Bias, Equalization and Sensitivity for Normal, Chrome or Metal position tapes—all within a few seconds. This assures low distortion, high output, flat frequency response, more accurate meter readings and better Dolby NR tracking.

Bulk erasing

Previously recorded music is erased as new recordings are made. However, to erase an entire tape, depress the amplifier's input selector (**AUX** or **TAPE 2**) whose input jacks are not connected and then depress the **REC/PAUSE** (●) and play (▶) buttons to start recording blank tape.

Reproduction

1. Appuyez sur le sélecteur d'inversion (**REV SELECT**) pour régler le mode.
- A:** Indique que la bande ne peut défilé que dans un sens, selon la touche qui est enfoncée: soit (◀), soit (▶).
- B:** Indique un cycle complet. La bande sera reproduite jusqu'à la fin de la face 1, s'inversera, la face 2 sera reproduite, et la bande s'arrêtera.
- C:** Indique une reproduction à l'infini. La bande continuera à s'inverser et à être reproduite jusqu'à ce que vous changiez la fonction.

Enregistrement

1. Appuyez sur la touche d'enregistrement/pause (●) pour passer au mode d'attente d'enregistrement.
 2. Appuyez sur le sélecteur d'inversion (**REV SELECT**) pour régler le mode.
- A:** Identique à ci-dessus, mais sur le mode d'enregistrement.
- B:** Sur ce mode, le GX-R99 Akai enregistrera un cycle complet (face A et face B), puis se mettra en reproduction continue de la bande qui vient juste d'être enregistrée.

Syntonisation automatique de bande

La fonction de syntonisation automatique de bande qui s'effectue automatiquement lorsque la touche d'enregistrement est enclenchée, donne les performances maximum avec n'importe quel type de bande. Le GX-R99 règle la polarisation, l'égalisation et la sensibilité optimales pour les bandes à position normale, chrome ou métal—tout cela en quelques secondes. Ceci assure une faible distorsion, une sorte é levée, une réponse en fréquence linéaire, des indications plus précises de l'indicateur et un meilleur alignement Dolby NR.

Effacement total

La musique précédemment enregistrée est effacée lorsque de nouveaux enregistrements sont effectués. Cependant, pour effacer la bande entière, il faut appuyer sur le sélecteur d'entrée de l'amplificateur (**AUX** ou **TAPE 2**) dont les jacks d'entrée ne sont pas connectés, puis appuyer simultanément sur les touches d'enregistrement/pause (●) et de lecture (▶) pour commencer l'enregistrement.

The Auto Monitor System Système automatique de contrôle

What is an auto monitor system?

The independent recording and playback heads in combination with two independent amplifiers (one for recording and another for playback) lets you listen to a recording as it is being made. This is called tape monitoring. By switching the tape monitor system during recording, you can compare the just recorded music (TAPE position) to the source music (SOURCE position). In this way you can make sure that you have set the recording input levels correctly. The tape monitoring system of the GX-R99 is called "auto monitor system". Beside letting you manually set the tape monitor system, it also does it automatically. When the GX-R99 is recording, the auto monitor system is set automatically to TAPE and during recording standby, it is set automatically to SOURCE. There is no need for you to set the auto monitor system yourself.



Qu'est-ce qu'un système automatique de contrôle?

Les têtes indépendantes d'enregistrement et de reproduction combinées à deux amplificateurs indépendants (l'un pour l'enregistrement, l'autre pour la reproduction), vous permettent d'écouter un enregistrement pendant qu'il s'effectue. Ceci est appelé contrôle de bande. En commutant le système de contrôle de bande pendant l'enregistrement, vous pouvez comparer la musique qui vient juste d'être enregistrée (position bande-TAPE) à la musique de source (position SOURCE). Cette méthode vous permet de vous assurer que vous avez correctement réglé les niveaux d'entrée d'enregistrement. Le système de contrôle de bande du GX-R99 est appelé "système automatique de contrôle". Non seulement il vous permet de régler manuellement le système de contrôle de bande, mais il le fait également automatiquement. Lorsque le GX-R99 Akai enregistre, le système automatique de contrôle est automatiquement réglé sur TAPE, et pendant l'attente d'enregistrement, il est automatiquement réglé sur SOURCE. Vous n'avez donc pas besoin de régler vous-même le système automatique de contrôle.

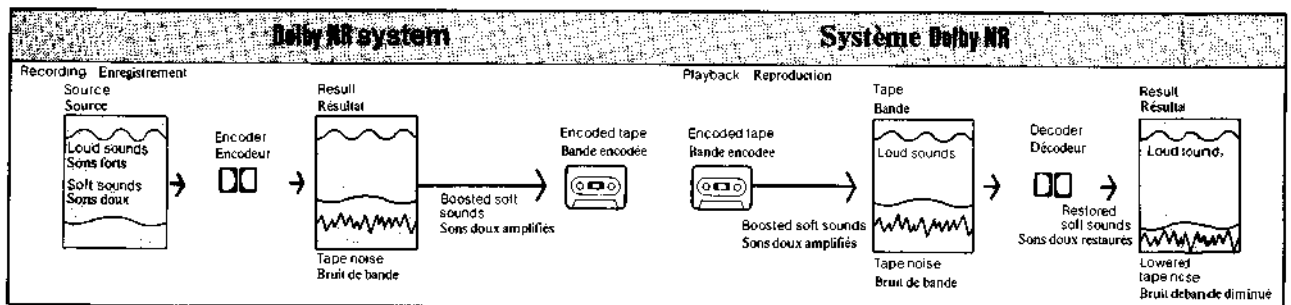

1. What is Dolby noise reduction (NR) system?

When you record without Dolby NR system, you can't hear the soft sounds very clearly because they are masked by noise added by the tape during recording. The Dolby NR system reduces this annoying tape noise. The Dolby NR encoder circuit boosts the low-level signals (soft sounds) during recording and at playback, the Dolby NR decoder lowers the low-level signals by exactly the same amount to restore the low-level signals to their original levels. At the same time, tape noise is lowered by the same amount. The result is reduction only in the unwanted tape noise.

2. What is the difference between Dolby B-type and C-type NR system?

B-type: This is the conventional Dolby NR system. It boosts or lowers the low-level signals at high frequencies only (more than 5 kHz) and reduces tape noise by 10 dB.

C-type: Compared to the Dolby B, it operates at lower frequencies (from 500 Hz) for uniform noise reduction across the audible spectrum. Tape noise is reduced by as much as 20 dB.

Therefore, you get better results with Dolby C, however when you are playing back tapes recorded with the conventional Dolby NR system, set the selector to Dolby B. Don't forget to always set the **DOLBY NR** system before recording or playing back a tape.

3. What is double process Dolby NR system?

In the conventional Dolby NR system, one circuit acts both as an encoder and as a decoder and is switched to become either one according to the need. In the double process Dolby NR system, there is an encoder circuit in the recording amplifier section and a decoder in the playback amplifier section. The double process Dolby NR system is used in cassette decks with 3 independent heads (recording, playback and erase). Therefore, when recording with Dolby NR, you can immediately confirm the effect of the Dolby NR system by monitoring the just recorded music.

* "Dolby" and the double-D symbol are trademarks of Dolby Laboratories Licensing Corporation. (Manufactured under license from Dolby Licensing Corporation.)

Système Dolby NR

1. Qu'est-ce que le système de réduction de bruit (NR) Dolby?

Lorsque vous enregistrez sans système Dolby NR, vous ne pouvez pas entendre très clairement les sons doux parce qu'ils sont masqués par le bruit ajouté par la bande pendant l'enregistrement. Le système Dolby NR réduit ce bruit de bande ennuyeux.

Le circuit encodeur Dolby NR amplifie les signaux de faible niveau (sons doux) pendant l'enregistrement, et, à la reproduction, le décodeur Dolby NR réduit les signaux de faible niveau d'exactly la même quantité pour ramener ceux-ci à leurs niveaux originaux. Le bruit de bande est en même temps diminué de la même quantité. Seul le bruit de bande indésirable est donc réduit.

2. Quelle est la différence entre les systèmes Dolby NR type B et type C?

Type-B: C'est le système Dolby NR conventionnel. Il n'amplifie ou ne réduit les signaux de faible niveau qu'aux hautes fréquences (supérieures à 5 kHz), et réduit le bruit de bande de 10 dB.

Type-C: Comparé au Dolby B, il est efficace sur des fréquences plus basses (à partir de 500 Hz) pour une réduction uniforme du bruit sur tout le spectre audible. Le bruit de bande est réduit de jusqu'à 20 dB.

Vous obtenez donc de meilleurs résultats avec Dolby C; cependant, lorsque vous reproduisez des bandes enregistrées avec le système Dolby NR conventionnel, réglez le sélecteur sur Dolby B. N'oubliez pas de toujours régler le système **DOLBY NR** avant d'enregistrer ou de reproduire une bande.

3. Qu'est-ce que le système Dolby NR double procédé?

Dans le système Dolby NR conventionnel, un seul circuit agit à la fois en tant qu'encodeur et décodeur, et il est commuté pour devenir l'un de ces deux éléments selon les besoins. Dans le système Dolby NR double procédé, il y a un circuit encodeur dans la section amplificateur d'enregistrement et un circuit décodeur dans la section amplificateur de reproduction. Le système Dolby NR double procédé est utilisé dans les magnéto-cassettes ayant 3 têtes indépendantes (enregistrement, reproduction et effacement). Lors d'un enregistrement avec Dolby NR, il vous est donc possible de vérifier immédiatement l'effet du système Dolby NR en reproduisant la musique qui vient juste d'être enregistrée.

* Dolby et le symbole Double D sont des marques déposées de Dolby Laboratories Licensing Corporation. (Fabriqué sous licence de Dolby Laboratories Licensing Corporation.)



Absentee recording and timed play back

Enregistrement autonome et reproduction programmée

Absentee recording

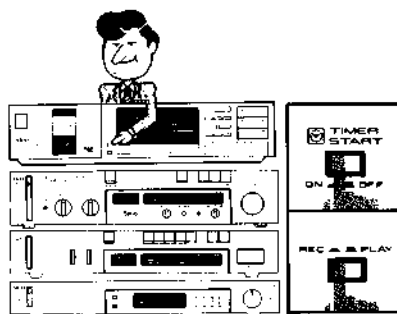

1. Turn **ON** the Akai GX-R99, the AMPLIFIER and the TUNER.
2. Load the cassette tape and Ready the Akai GX-R99 for RECORDING.
3. Set the AUDIO TIMER COMPONENT to turn ON and OFF the components.
4. Set the TUNER to tune in the station you want to record.
5. Set the recording level of the GX-R99.
6. Set the AMPLIFIER's SPEAKER switches to OFF and the VOLUME control to ZERO.
7. Set the AUDIO TIMER COMPONENT to carry out absentee recording.
 - * All the connected components will be turned off.
8. Set the Akai GX-R99 **TIMER START** selector to **REC** ().



Enregistrement autonome

1. Mettez sous tension le GX-R99 Akai, l'AMPLIFICATEUR et le TUNER.
2. Chargez une bande cassette et préparez le GX-R99 Akai à l'ENREGISTREMENT.
3. Réglez la MINUTERIE AUDIO pour qu'elle mette les éléments sous tension et hors circuit.
4. Réglez le TUNER pour syntoniser la station que vous désirez enregistrer.
5. Réglez le niveau d'enregistrement du GX-R99.
6. Réglez les commutateurs HAUT-PARLEUR de l'AMPLIFICATEUR sur arrêt (OFF) et la commande de VOLUME sur ZERO.
7. Réglez la MINUTERIE AUTO pour qu'elle effectue l'enregistrement autonome.
 - * Tous les éléments connectés seront mis hors circuit.
8. Réglez le commutateur de démarrage minuterie (TIMER START) du GX-R99 Akai sur enregistrement (REC ).



Timed playback

1. Turn ON the Akai GX-R99 and the AMPLIFIER.
2. Set the AMPLIFIER's SPEAKER switches and the VOLUME control.
3. Load a cassette tape and Playback the tape. When you find the beginning of the selection you want, depress the **STOP** () button.
4. Set the AUDIO TIMER COMPONENT to turn ON and OFF the components.
5. Set the AUDIO TIMER COMPONENT to carry out timed playback.
6. Set the Akai GX-R99's **TIMER START** selector to **PLAY** ().



Attention

After absentee recording or timed playback, set the **TIMER START** switch to **OFF** () before turning on the Akai GX-R99.

Notes:

- Although the reverse display may show continuous play () in the recording mode, the tape will just make one cycle and then stop (). This is to protect the recording from being erased.
- Set the timer to turn on a few seconds in advance of the source music to allow for the Auto Tuning function to take place.



Reproduction programmée

1. Mettez sous tension le GX-R99 Akai et l'AMPLIFICATEUR.
2. Réglez les commutateurs HAUT-PARLEUR de l'AMPLIFICATEUR et la commande de VOLUME.
3. Chargez une bande cassette et reproduisez la bande. Lorsque vous trouvez le début de la sélection que vous voulez, appuyez sur la touche d'arrêt (STOP ).
4. Réglez la MINUTERIE AUDIO pour qu'elle mette les éléments sous tension et hors circuit.
5. Réglez la MINUTERIE AUDIO pour qu'elle effectue la reproduction programmée.
6. Réglez le commutateur de démarrage minuterie (TIMER START) du GX-R99 Akai sur lecture (PLAY ).

Attention

Après un enregistrement autonome ou une reproduction programmée, réglez le commutateur de démarrage minuterie (TIMER START) sur arrêt (OFF ) avant de mettre le GX-R99 Akai sous tension.

Remarques:

- Bien que l'affichage d'inversion puisse indiquer une lecture continue () sur le mode d'enregistrement, la bande n'enregistrera que sur un cycle et s'arrêtera (). Ceci afin d'éviter que l'enregistrement soit effacé.
- Réglez la minuterie pour qu'elle se mette sous tension quelques secondes avant la musique de source afin de permettre à la fonction de syntonisation automatique de s'effectuer.

Connections Connexions

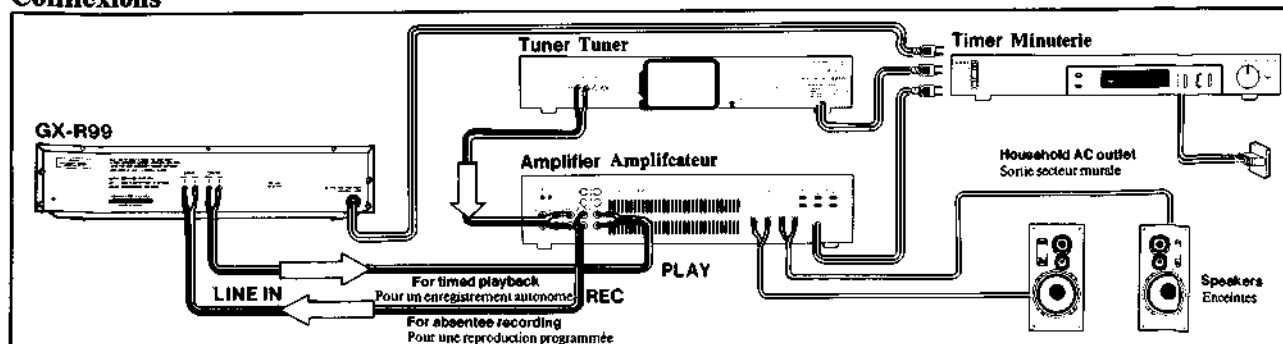

The MPX FILTER switch Commutateur filtre MPX (MPX FILTER)

What is the MPX FILTER?

FM signals contain 19 kHz pilot signals and 38 kHz subcarrier signals which convey the left and right channel information. These signals are necessary, but they must be removed from the output signals of the tuner. If these signals are not removed, they can affect the **DOLBY NR** system. The **MPX FILTER** is designed to remove these signals before they can be recorded.

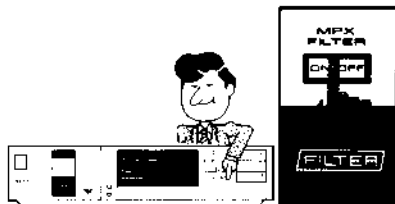

Qu'est-ce qu'un filtre MPX?

Les signaux MF contiennent des signaux pilotes de 19 kHz et des signaux de sous-porteuse de 38 kHz qui transmettent les informations des canaux droit et gauche. Ces signaux sont nécessaires, mais ils doivent être supprimés des signaux de sortie du tuner. Si ces signaux ne sont pas supprimés, ils peuvent affecter le système **DOLBY NR**. Le filtre **MPX** est conçu pour supprimer ces signaux avant qu'ils soient enregistrés.

When to use the MPX FILTER switch

Use this switch only when you are recording with **DOLBY NR**. Most high quality tuners have filters to suppress these signals and with these tuners, you can leave the Akai GX-R99's **MPX FILTER** switch off. With tuners that do not have filters or those with inadequate filters, you should turn on the **MPX FILTER** switch. Or, when you tape monitor the just recorded music and feel that the sound quality is not right, turn on the **MPX FILTER** switch. At other times, leave it OFF.

Quand utiliser le filtre MPX?

N'utilisez ce commutateur que lors d'un enregistrement avec **DOLBY NR**. Cependant, la plupart des tuners de haute qualité sont équipés de filtres qui suppriment ces signaux, et avec ces tuners, le commutateur filtre **MPX** du GX-R99 Akai peut être laissé hors circuit. Avec les tuners qui ne sont pas équipés de filtres ou ceux dont les filtres ne sont pas appropriés, le commutateur filtre **MPX** doit être mis sous tension. Ou, lorsque vous contrôlez la musique qui vient juste d'être enregistrée, si la qualité sonore ne vous semble pas bonne, mettez sous tension le filtre **MPX** les autres fois, le laisser hors circuit.

Auto tape selector

How tape positions are detected

Cassette tapes can be separated widely into three types: normal position, chrome (CrO₂) position and metal position. Tape performances differ according to tape position and to fully utilize the performance of each tape, the cassette deck's recording/playback characteristics such as bias and equalization must be set of suit each tape position.

The Akai GX-R99 is equipped with an auto tape selector which automatically detects the tape position and sets the ideal bias and equalization. All you have to do is load a cassette tape.

The detected tape position is displayed on the FL display (**NORMAL**, CrO₂ or **METAL**).

Sélecteur automatique de bande

Comment sont détectées les positions de bande.

Les bandes cassettes peuvent être divisées en trois types principaux: à position normale, à position chrome (CrO₂) et à position métal. Les performances des bandes diffèrent selon la position de bande et pour utiliser pleinement les performances de chaque bande, les caractéristiques d'enregistrement/reproduction du magnétocassette, telles que la polarisation et l'égalisation doivent être réglées en fonction de chaque type de bande.

Le GX-R99 est équipé d'un sélecteur automatique de bande qui détecte automatiquement la position de bande et règle la polarisation et l'égalisation idéales. Il vous suffit de charger une bande cassette.

La position de bande détectée est indiquée sur l'affichage fluorescent (**NORMAL**: normale, CrO₂; chrome, **METAL**: métal).

How the auto tape selector operates

When a cassette tape is loaded, the Akai GX-R99 detects the tape position by the special notches on the cassette case.

Comment fonctionne le sélecteur automatique de bande.

Lorsqu'une bande cassette est chargée, le GX-R99 détecte la position de bande grâce aux encoches spéciales qui se trouvent sur la cassette.

Attention

- Do not use a cassette tape which does not have notches for triggering its tape position. You will not be able to get optimum recordings.
- We do not recommend the use of ferri-chrome cassette tapes.

Attention

- N'utilisez pas de bande cassette non munie d'encoches pour déclencher la position de bande. Il vous serait impossible d'obtenir des enregistrements optimum.
- Nous déconseillons l'utilisation de bandes en ferrichrome.

OUTPUT/PHONES control

When an external amplifier is employed, it is necessary to match the line output level of the GX-R99 to the playback level of the external amplifier so that when a tape is played back the amplifier's volume control need not be readjusted.

1. Consider the listening level of an FM broadcast through the amplifier as standard.
 2. Play back a prerecorded tape.
 3. Set the Monitor selector of the amplifier to Tape and listen to the tape.
 4. If the listening level is different from that of the standard listening level, adjust the GX-R99 **OUTPUT** control.
 5. Set the Monitor selector of the amplifier to Source and listen to the standard listening level.
 6. If the listening level from the tape is still different from the standard listening level, adjust the GX-R99 **OUTPUT** control again.
 7. Repeat steps 3 to 6 until there is no difference.
- In normal use, set the **OUTPUT/PHONES** control to around 5. However, when listening through speakers, if you feel that the sound is too loud, lower the control.

When using the GX-R99 as a playback cassette deck during tape dubbing, set the control to maximum.

Commande sortie/casque (OUTPUT/PHONES)

Lorsqu'un amplificateur extérieur est utilisé, il est nécessaire de faire correspondre le niveau de sortie de ligne du GX-R99 au niveau de reproduction de l'amplificateur extérieur de sorte que, lorsqu'une bande est reproduite, la commande de volume de l'amplificateur ne doive pas être réajustée.

1. Considérez le niveau d'écoute, par l'amplificateur, d'une émission MF, comme étant le niveau standard.
2. Reproduisez une bande pré-enregistrée.
3. Réglez le sélecteur de contrôle de l'amplificateur sur bande (**TAPE**) et écoutez la bande.
4. Si le niveau d'écoute est différent du niveau d'écoute standard, réglez la commande de sortie (**OUTPUT**) du GX-R99.
5. Réglez le sélecteur de contrôle de l'amplificateur sur Source et écoutez le niveau standard.
6. Si le niveau d'écoute de la bande est encore différent du niveau d'écoute standard, réglez à nouveau la commande sortie (**OUTPUT**) du GX-R99.
7. Répétez les opérations 3 à 6 jusqu'à ce qu'il n'y ait plus de différence.

Pour une utilisation normale, réglez la commande de sortie/casque (**OUTPUT/PHONES**) autour de 5. Cependant, lors d'une écoute par les haut-parleurs, si vous sentez que le son est trop fort, modifiez le réglage de la commande. Réglez cette commande au maximum lors de l'utilisation du GX-R99 en tant que magnétocassette de reproduction pendant un doublage de bande.

SECTION 2

SERVICE MANUAL

TABLE OF CONTENTS

I.	SPECIFICATIONS	20
II.	DISMANTLING OF UNIT	21
III.	CONTROLS	22
IV.	PRINCIPAL PARTS LOCATION	24
V.	MECHANICAL ADJUSTMENT	26
	5-1 PINCH ROLLER PRESSURE MEASUREMENT	26
	5-2 WINDING TORQUE MEASUREMENT IN EACH MODE	26
	5-3 HOW TO INSTALL VOLUME (VR901) AND CAM WHEEL	27
	5-4 POTENTIOMETER PRESET VOLTAGE ADJUSTMENT	28
	5-5 TAPE SPEED ADJUSTMENT	30
VI.	HEAD ADJUSTMENT	31
	6-1 TAPE GUIDE HEIGHT ADJUSTMENT	31
	6-2 HEAD HEIGHT ADJUSTMENT	32
	6-3 REC/PB HEAD AZIMUTH ADJUSTMENT	32
	6-4 HEAD BLOCK PROJECTION ADJUSTMENT	32
VII.	ELECTRICAL ADJUSTMENT	33
	7-1 QUICK REVERSE SENSITIVITY ADJUSTMENT	33
	7-2 PRE-AMP PCB ADJUSTMENT	34
	7-3 TUNING PCB ADJUSTMENT	36
VIII.	DC RESISTANCE OF VARIOUS COILS	41
IX.	CLASSIFICATION OF VARIOUS P.C BOARDS	42
	9-1 P.C BOARD TITLES AND IDENTIFICATION NUMBERS	42
	9-2 COMPOSITION OF VARIOUS P.C BOARDS	43

For basic adjustments, measuring methods, and operating principles, refer to GENERAL TECHNICAL MANUAL.

I. SPECIFICATIONS

TRACK SYSTEM	4 Track 2 channel Stereo System
TAPE	Philips Type Cassette
HEADS	Erase Heads × 2 Super GX Head for recording × 1 Super GX Head for playback × 1
MOTORS	FG Servo D.D. motor for direct capstan drive × 2 DC motor for reel drive × 1 DC motor for mecha drive × 1
WOW & FLUTTER	0.08% WTD (DIN) 0.028% W.RMS ±0.055% W.Peak (EIAJ)
TAPE WINDING TIME	90 sec. Using a C-60 cassette tape
FREQUENCY RESPONSE	Normal: 20 to 18,000 Hz ± 3 dB (EIAJ) CrO ₂ : 20 to 21,000 Hz ± 3 dB (EIAJ) Metal: 20 to 21,000 Hz ± 3 dB (EIAJ)
S/N RATIO	60 dB (Measured Via tape with peak recording level, Metal Tape) 56 dB (EIAJ): Metal Dolby B-type NR switch ON: Improves up to 5 dB at 1 kHz, 10 dB above 5 kHz Dolby C-type NR switch ON: Improves up to 15 dB at 500 Hz, 20 dB at 1 kHz to 10 kHz
HARMONIC DISTORTION	1 kHz, 3rd Harmonic distortion Metal: 0.5% (EIAJ)
INPUT	Line 70 mV (Input Impedance: 47 kohms)
OUTPUT	Line 410 mV at 0 VU Required load impedance: 250 ohms Phone: 1.3 mW/8 ohms at 0 VU
POWER REQUIREMENTS	100V, 50/60 Hz for Japan 120V, 60 Hz for USA and Canada 220V, 50 Hz for Europe except UK 240V, 50 Hz for UK and Australia 110V/120V/220V/240V, 50/60 Hz switchable for other countries.
POWER CONSUMPTION	J model: 45W
DIMENSIONS	440 (W) × 105 (H) × 372 (D) mm (EIAJ)
WEIGHT	8.7 kg

* For improvement purposes, specification and design are subject to change without notice.

* Noise reduction manufactured under license from Dolby Laboratories Licensing Corporation. "Dolby" and the double-D symbol are trade marks of Dolby Laboratories Licensing corporation.

II. DISMANTLING OF UNIT

In case of trouble, etc. necessitating dismantling, please dismantle in the order shown in the photographs. Reassemble in reverse order.

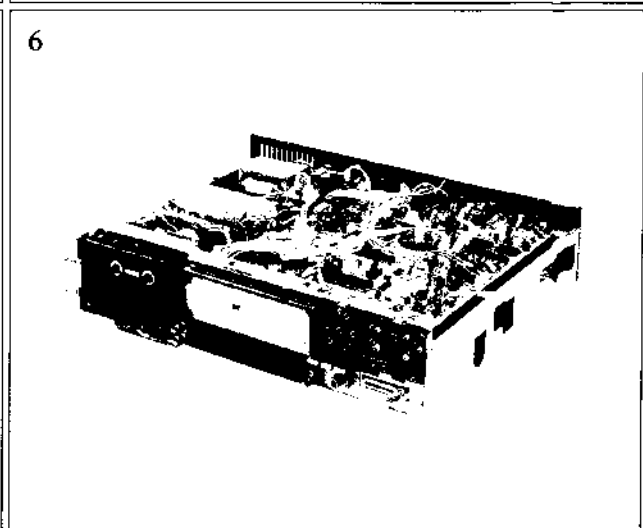
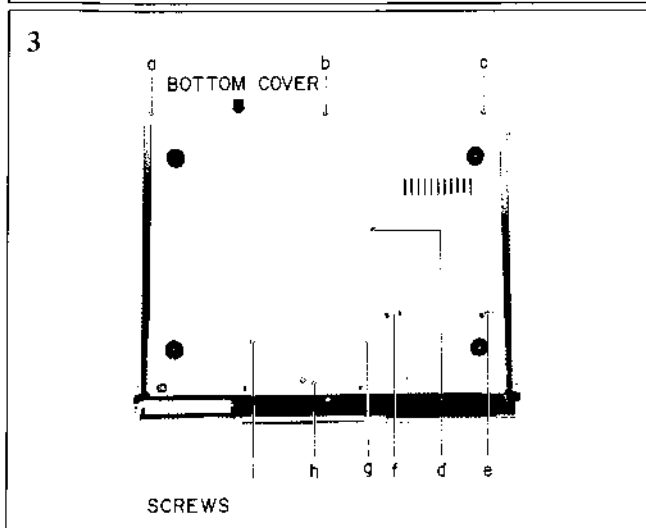
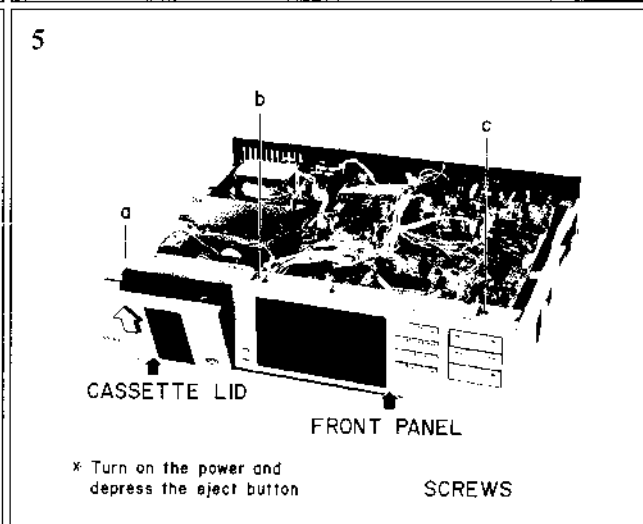
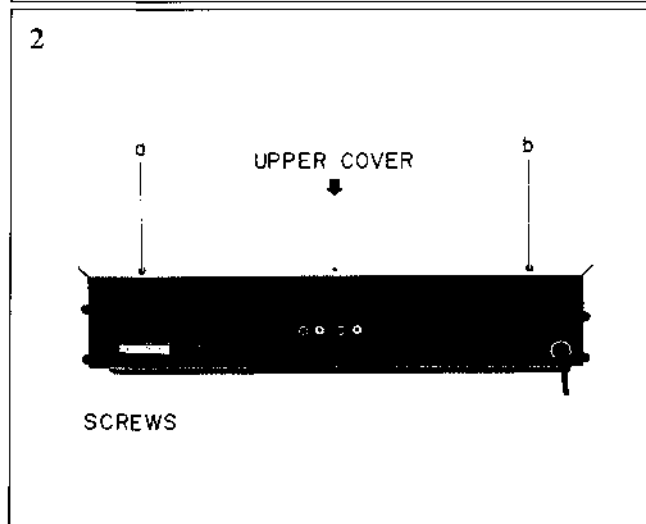
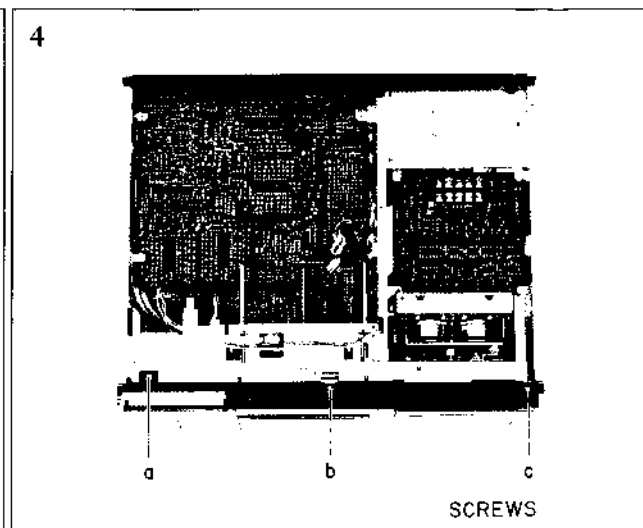
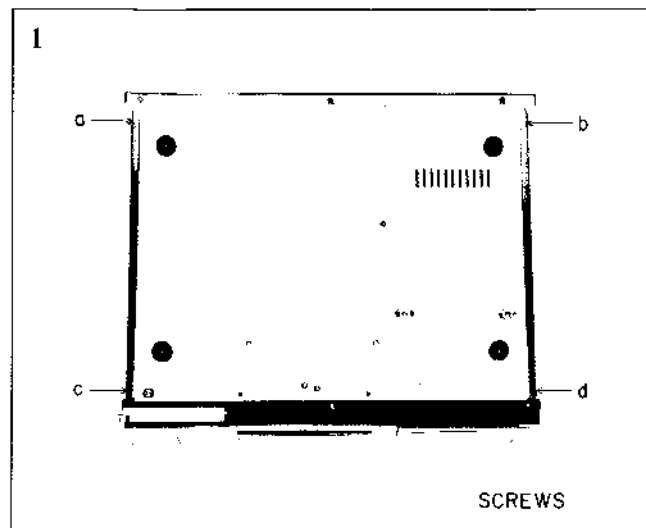

III. CONTROLS

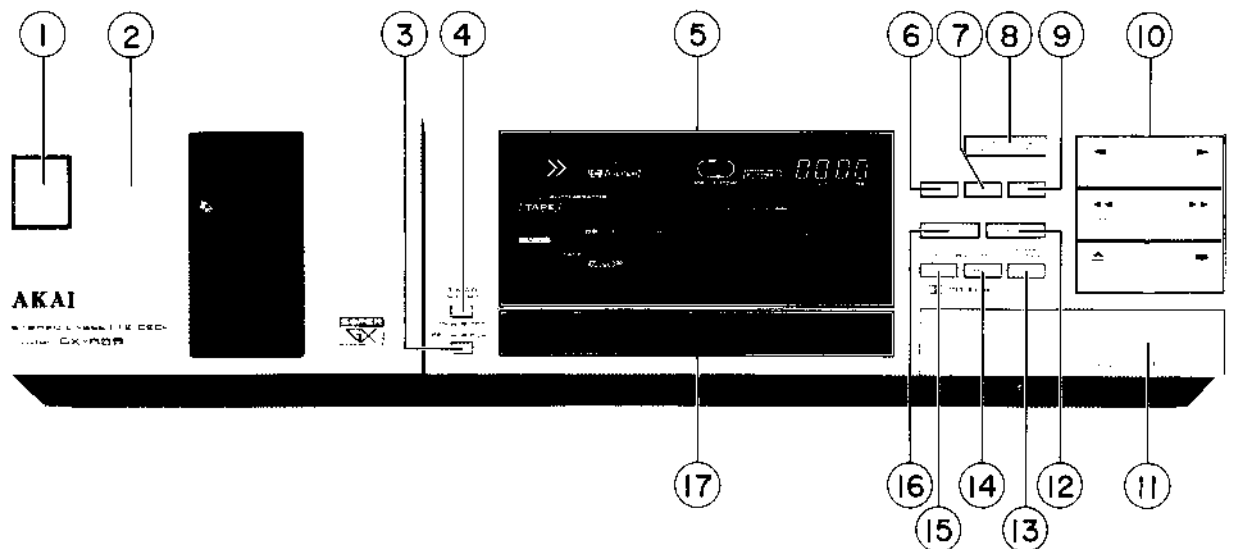

Fig. 3-1 Front View

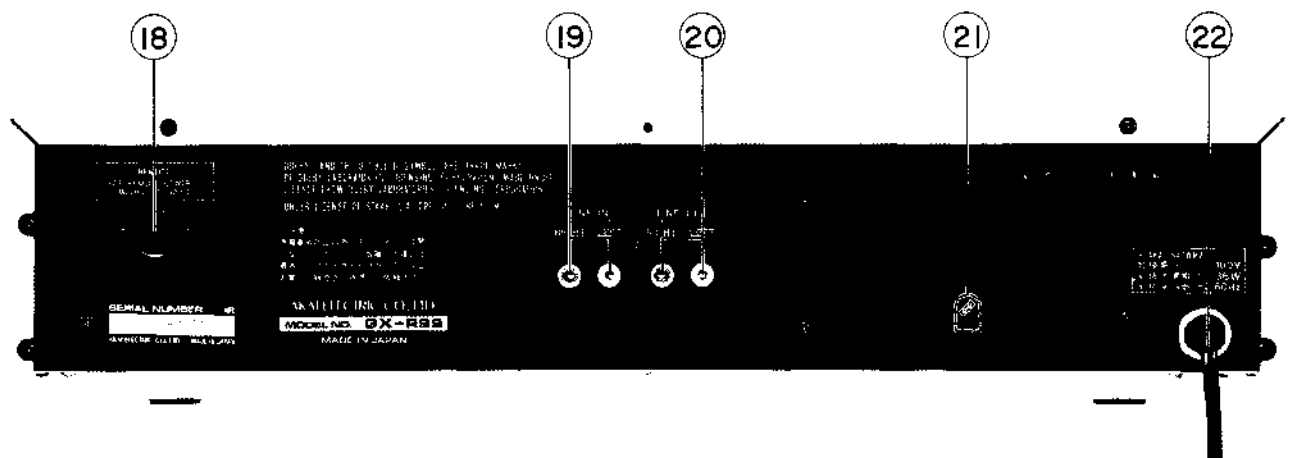

Fig. 3-2 Rear View

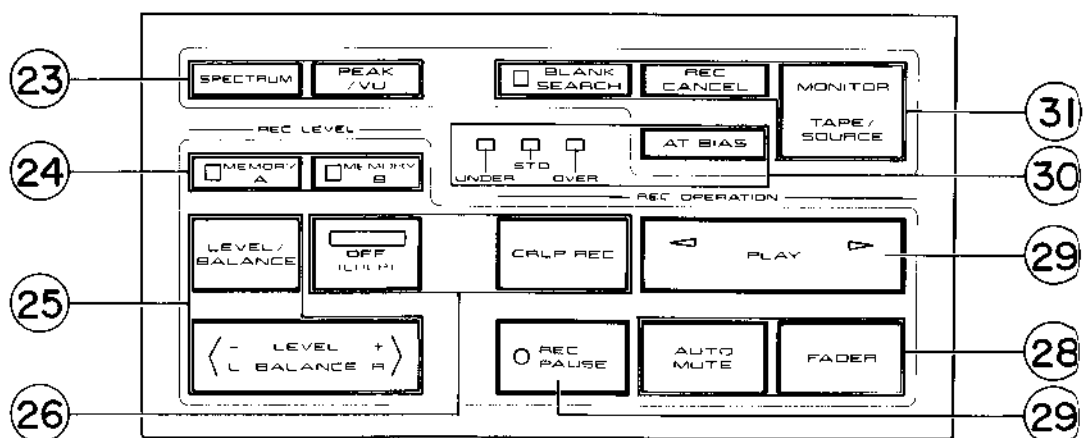

Fig. 3-3 Top View

IV. PRINCIPAL PARTS LOCATION

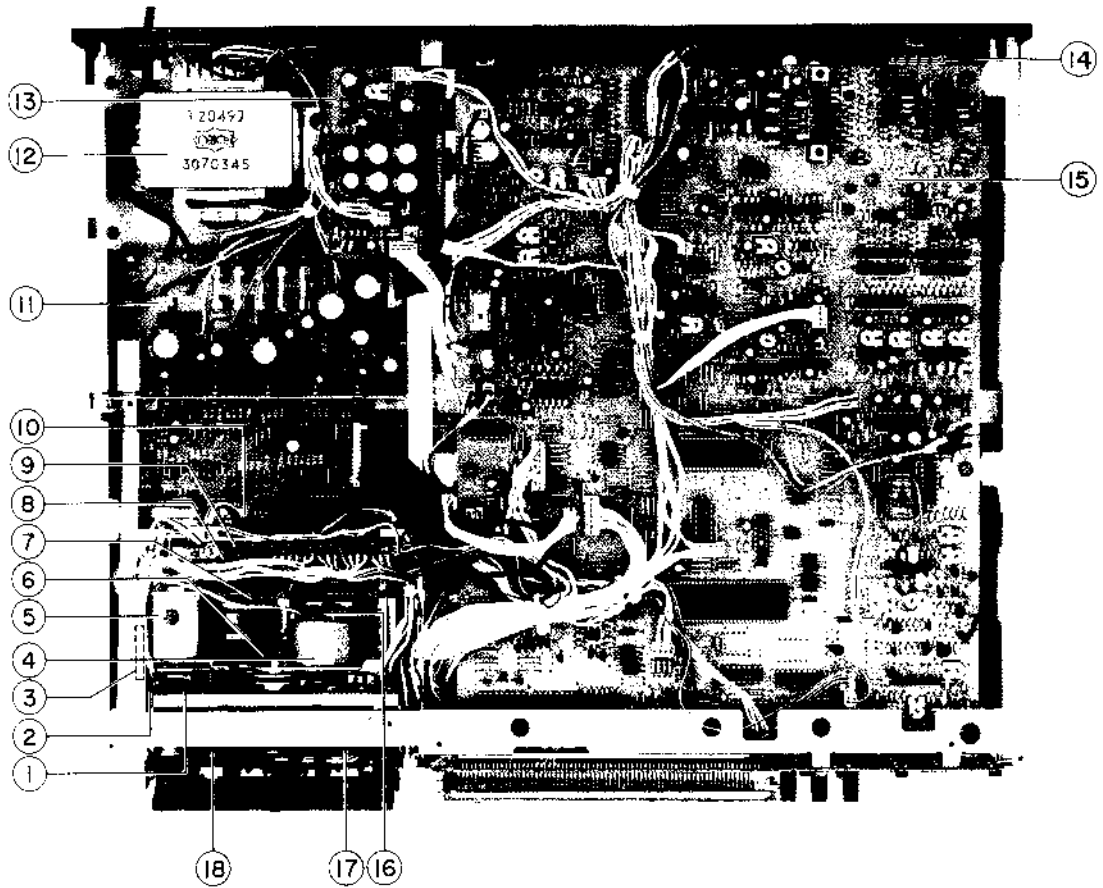

Fig. 4-1 Top View

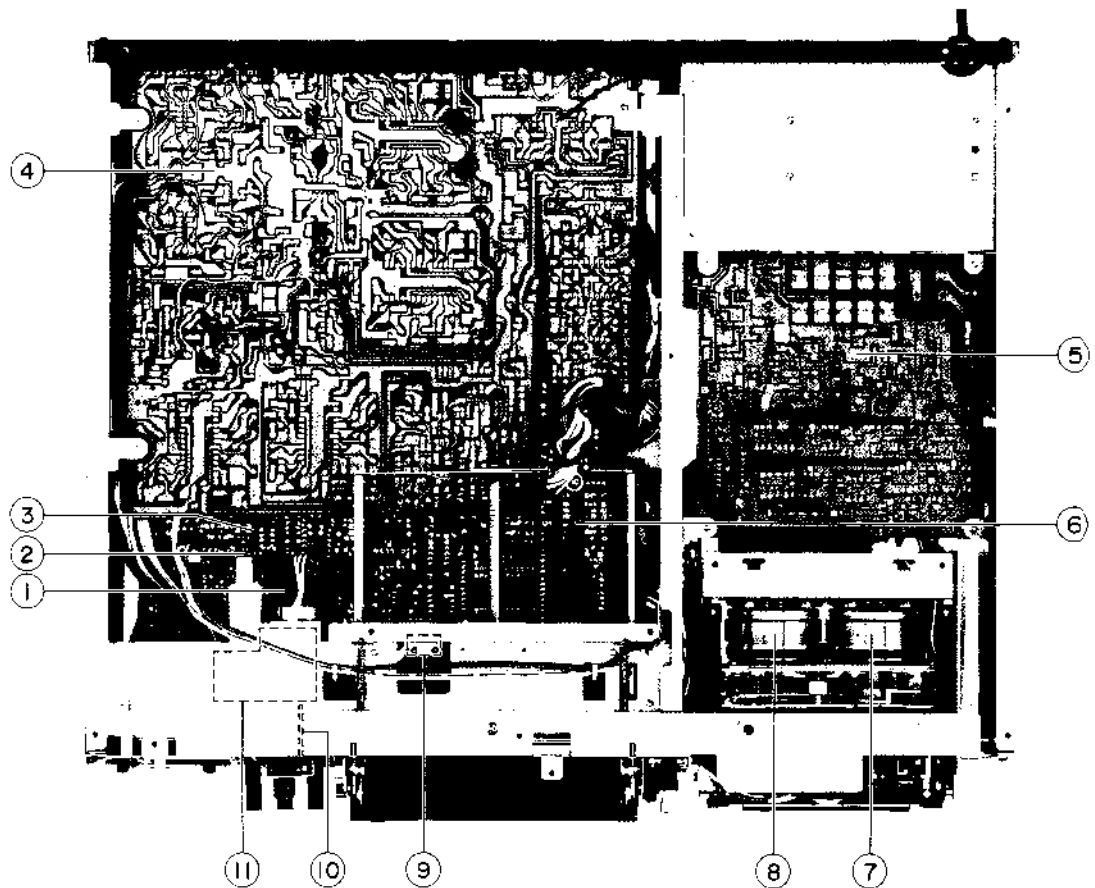

Fig. 4-2 Bottom View

Front View

1. POWER BUTTON
2. CASSETTE HOLDER
3. TIMER REC/PB BUTTON
4. TIMER START BUTTON
5. FL DISPLAY
6. COUNTER RESET BUTTON
7. COUNTER MODE BUTTON
(ELAPSED, REMAIN or COUNTER)
8. REVERSE ELECTOR BUTTON
9. TAPE BUTTON (LC46, C46, C60 or C90)
10. TAPE CONTROL BUTTON
11. HEADPHONES & OUTPUT CONTROL
12. IPLS BUTTON
13. MPX FILTER ON/OFF BUTTON
14. DOLBY NR B/C BUTTON
15. DOLBY NR ON/OFF BUTTON
16. QMSS (Quick Memory Search System) BUTTON
17. MOTORIZED CRLP

Rear View

18. REMOTE CONTROL JACK
19. LINE IN (L/R) JACKS
20. LINE OUT (L/R) JACKS
21. VOLTAGE SELECTOR (U) model only)
22. AC POWER CORD

Top View

23. SWITCHES FOR VU, PEAK AND SPECTRUM METERS
24. RECORDING LEVEL MEMORY BUTTONS
25. BALANCE AND VOLUME CONTROLS
26. CRLP AUTOMATIC AND MANUAL CONTROLS
27. RECORDING PAUSE BUTTON
28. AUTO MUTE AND FADER BUTTONS
29. PLAY AND RECORDING START BUTTON
30. AT BIAS SELECTOR AND INDICATORS
31. BLANK SEARCH SYSTEM, RECORDING CANCEL
AND TAPE/SOURCE MONITOR BUTTONS

V. MECHANICAL ADJUSTMENT

5-1 PINCH ROLLER PRESSURE MEASUREMENT (Refer to Fig. 5-1)

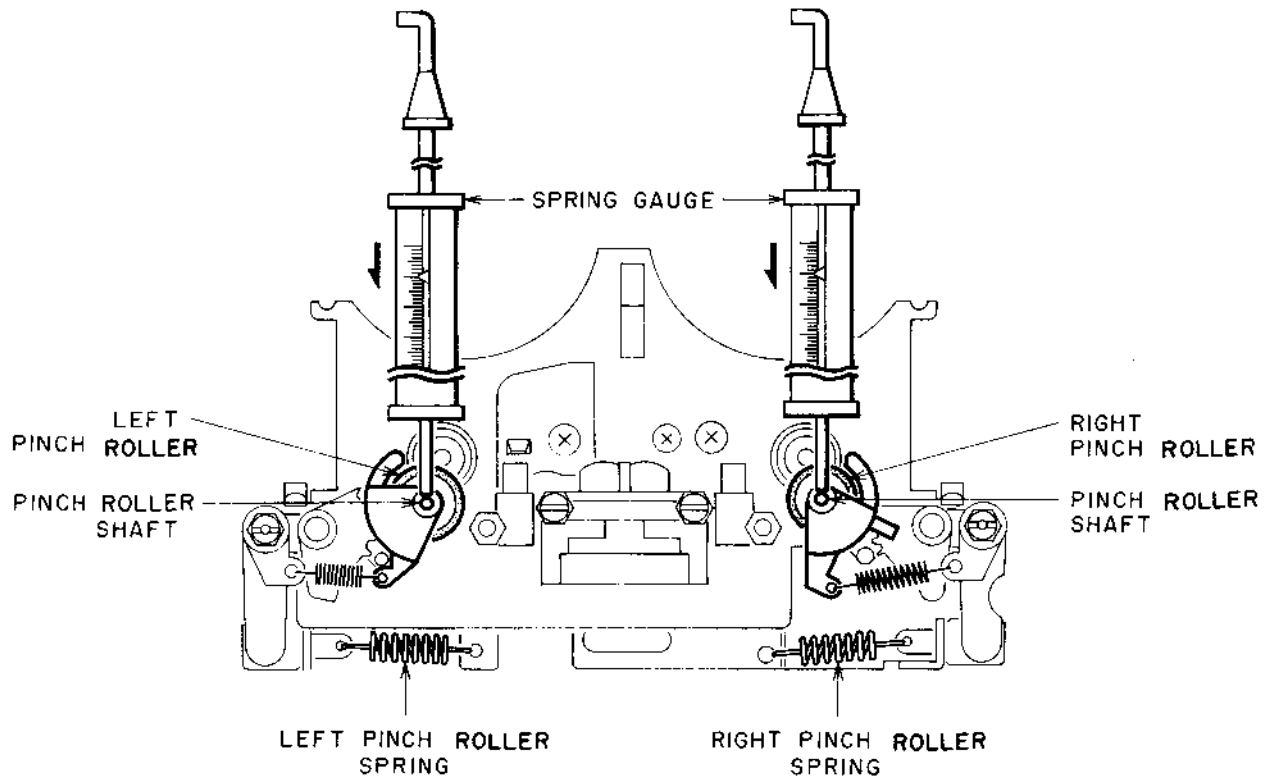

Fig. 5-1

Put in FWD PLAY mode. Push pinch roller shaft down with the spring gauge, and push the pinch roller 1 to 2 mm away from the capstan and release slowly.

Read the spring gauge at the moment the pinch roller touches the capstan and begins to rotate. Specified contact, pressures measurement is

RIGHT SIDE: 450 ± 80 grams

LEFT SIDE: 400 ± 80 grams

Confirm that the pinch roller pressure at REV PLAY mode

RIGHT SIDE: 400 ± 80 grams

LEFT SIDE: 450 ± 80 grams

If there is no measurement obtained, replace the pinch roller spring.

5-2 WINDING TORQUE MEASUREMENT IN EACH MODE (Refer to Fig. 5-2)

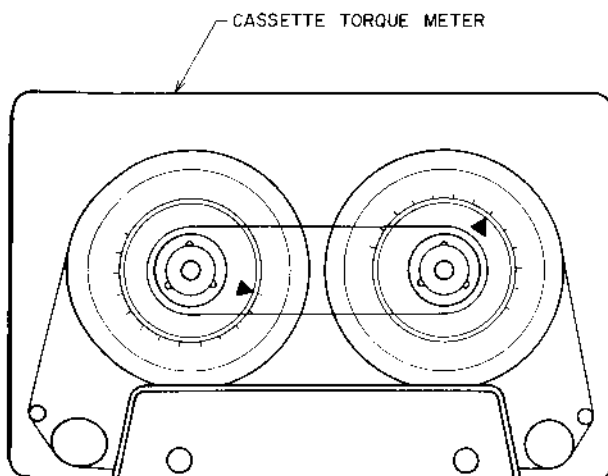

Fig. 5-2

Insert a cassette torque meter (AJ-751179) and measure in each mode. For Fast Forward and Rewind, measure at the end of the tape when the tape has stopped running.

Forward or Reverse mode

Take up Torque: 40^{+15}_{-10} g-cm

Back Tension Torque: 17 ± 3 g-cm

Fast Forward or Rewind mode

Take up Torque: 100^{+50}_{-30} g-cm

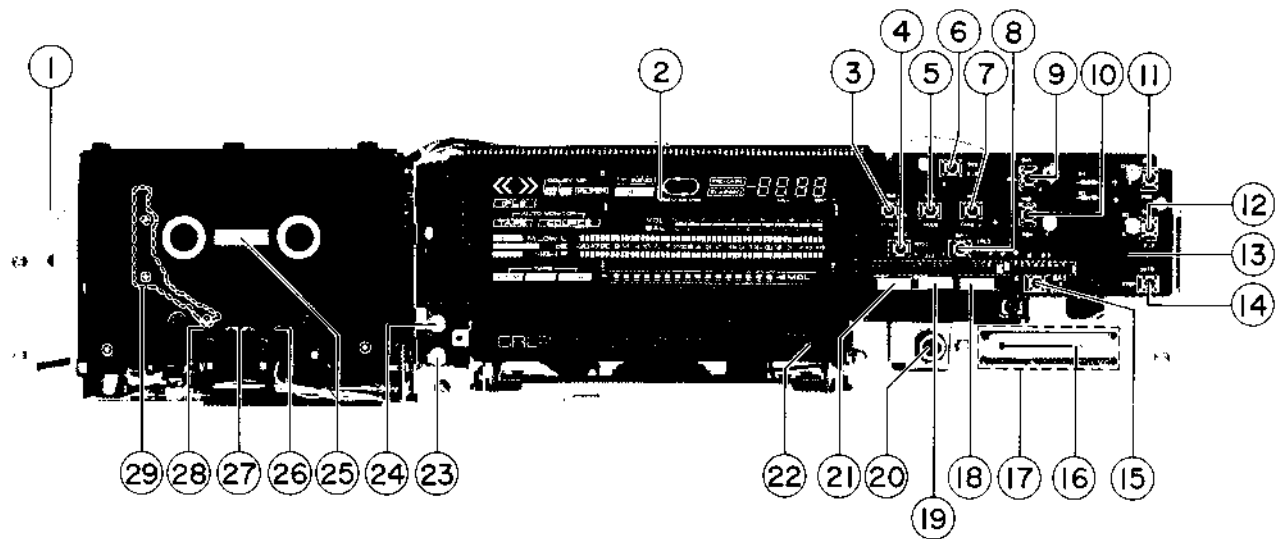

Fig. 4-3 Front View

Top View

1. HOLDER REEF SW PCB
2. LOADING SWITCH SW901
3. POTENTION PCB
4. REEL MOTOR M903
5. CAM MOTOR M904
6. FG PCB
7. MOTOR PCB
8. SERVO PCB
9. CONNECTOR A PCB
10. CONNECTOR B PCB
11. POWER SUPPLY PCB
12. POWER TRANS T901
13. POWER SUPPLY II PCB
14. REMOTE CONTROL PCB
15. TUNNING PCB
16. FILTER PCB
17. DETECTOR (R) PCB
18. DETECTOR (L) PCB

Botton View

1. DOOR MOTOR M905
2. (DOOR) MOTOR PCB
3. SYSCON PCB
4. PRE AMP PCB
5. POWER SUPPLY PCB
6. REC PCB
7. CAPSTAN MOTOR M902
8. CAPSTAN MOTOR M901
9. SWITCH (DOOR) PCB
10. HEAD PHONE PCB
11. SWITCH PCB

Front View

1. POWER SWITCH
2. FL DISPLAY
3. COUNTER RESET SW5
4. QMSS SW10
5. MODE SW6
6. REV SELECT SW2
7. TAPE SW7
8. IPLS SW11
9. REV SW3
10. REW SW8
11. FWD SW4
12. F.F SW9
13. METER PCB
14. STOP SW13
15. EJECT SW12
16. OUTPUT LEVEL VR1
17. OUT VOLUME PCB
18. MPX FILTER SW1-3
19. DOLBY NR B/C SW1-2
20. HEAD PHONE (PHONES) J5
21. DOLBY NR ON/OFF SW1-1
22. DOOR OPEN/CLOSE SW19
23. TIMER REC/PLAY SW16
24. TIMER START SW15
25. D LED D901
26. REV ERASE HEAD H902 E4-11
27. REC/PB HEAD H901 RP4-10
28. FWD ERASE HEAD /QUICK REVERSE DETECTOR (D902) E4-11S
29. LED PCB

5-3 HOW TO INSTALL VOLUME (VR901) AND CAM WHEEL (Refer to Fig. 5-3)

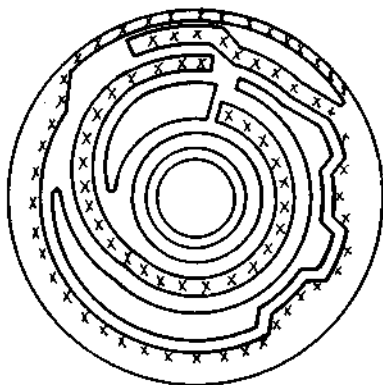
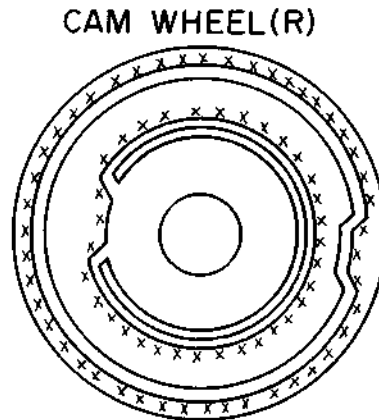
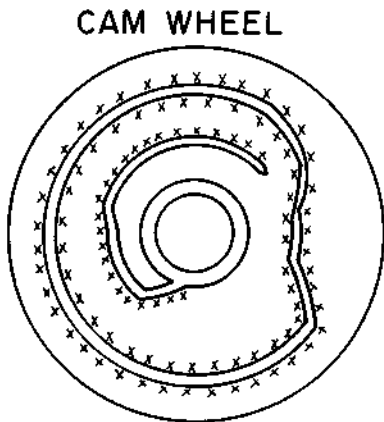
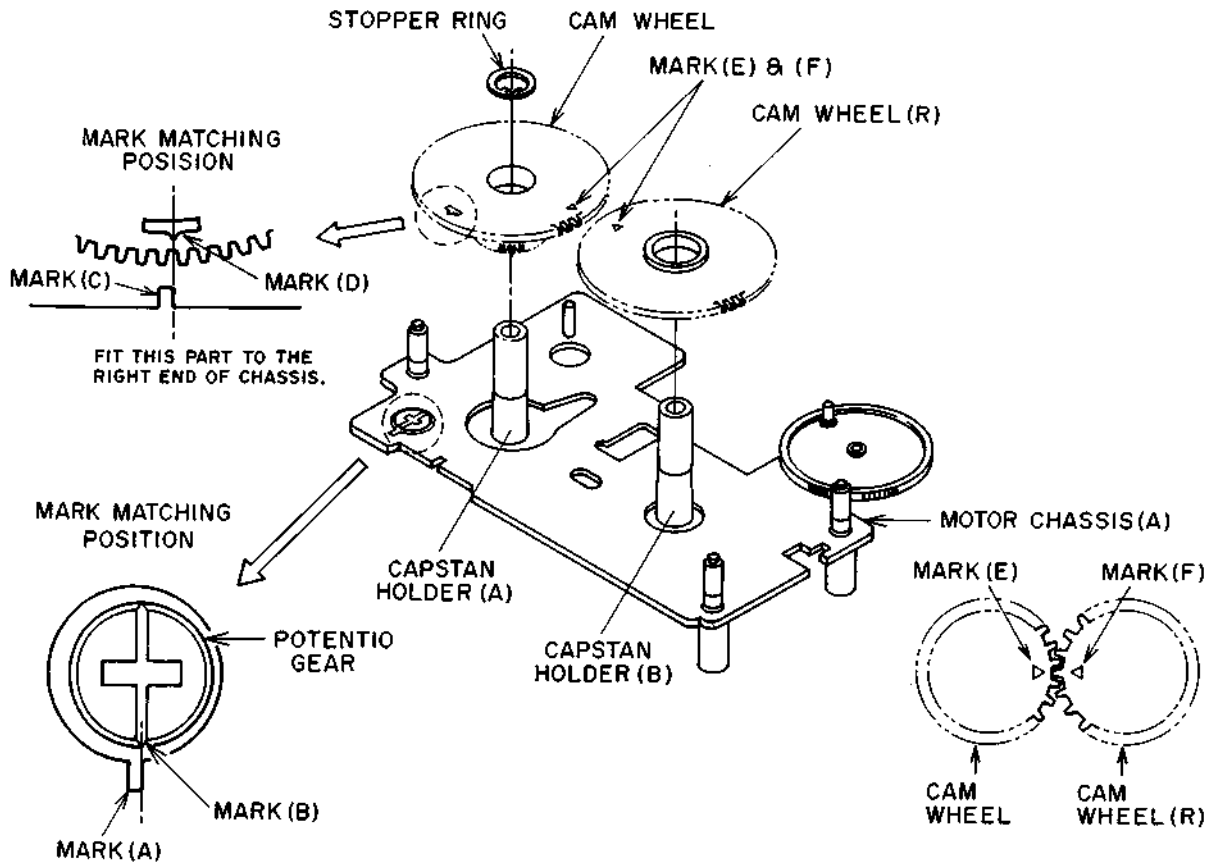

Fig. 5-3

- 1) Fitting position volume (potentio gear)
Fit the right end of Mark (A) to the center of Mark (B) as shown in the Figure. (Fig. 5-3 ①)
- 2) Apply Molybdenum coat on the specified area indicated in "X" (Fig. 5-3 ②)
- 3) Set the cam wheel on the capstan holder (A). When the cam wheel is set properly, fit the center of Mark (D) to the right end of Mark (C). (Fig. 5-3 ③)
- 4) Fit the stopper ring in the groove of the capstan holder.
- 5) Set the cam wheel (R) on the capstan holder (B). When the cam wheel (R) is set properly, fit the center of Mark (E) to the center of Mark (F). (Fig. 5-3 ④)

5-4 POTENTIO METER PRESET VOLTAGE ADJUSTMENT (Refer to Figs. 5-4 to 5-8)

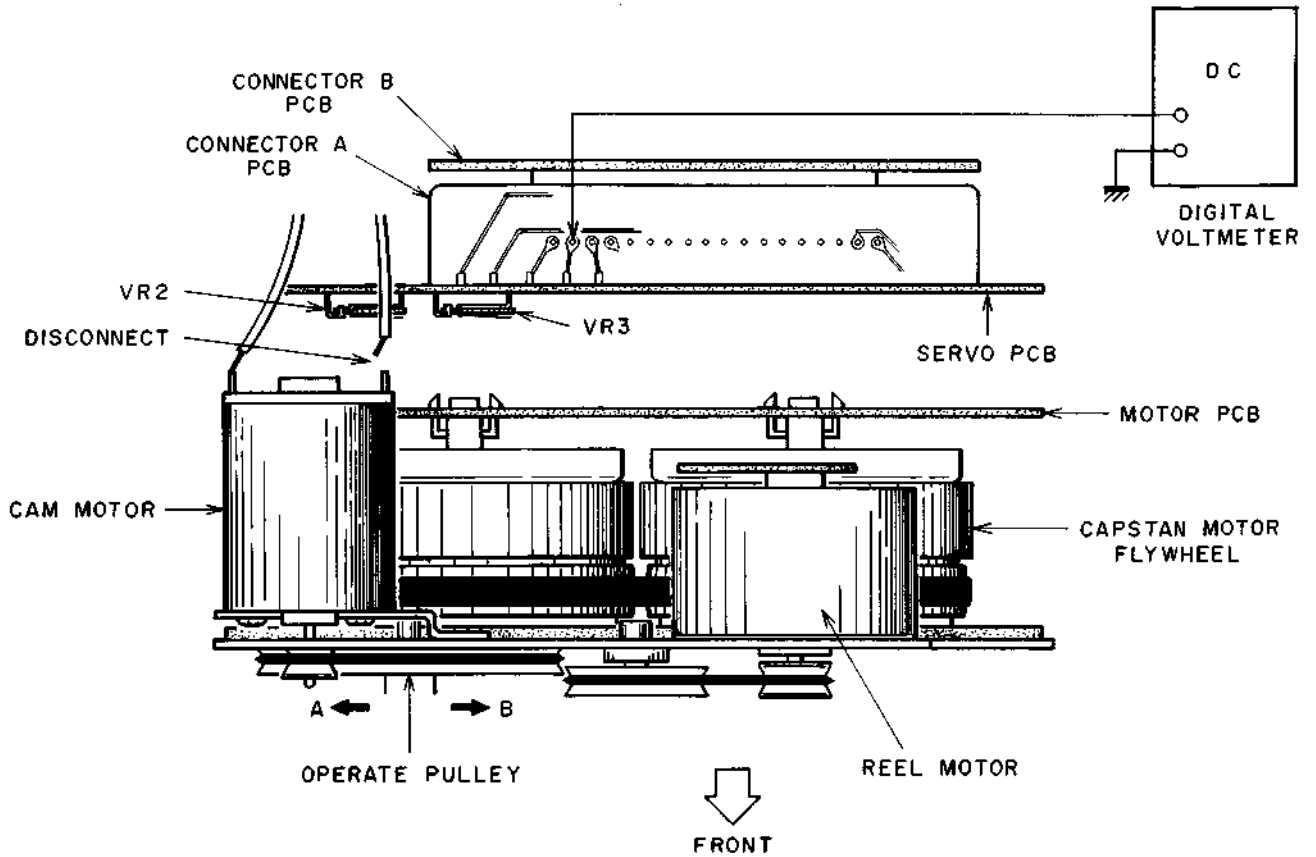

Fig. 5-4

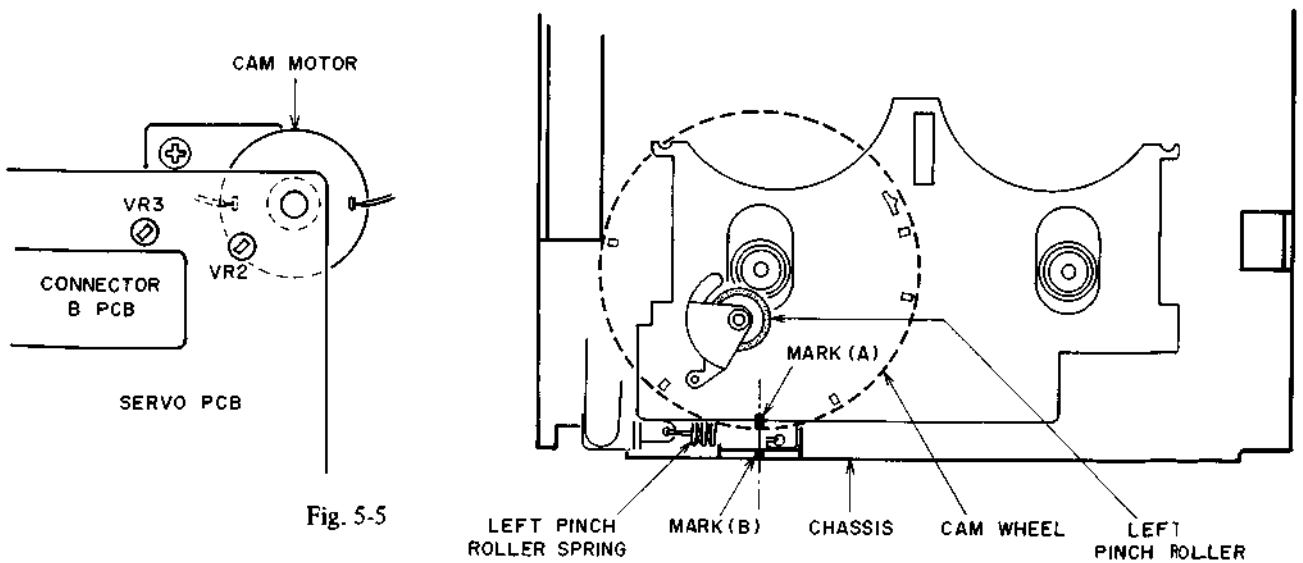

Fig. 5-5

Fig. 5-6

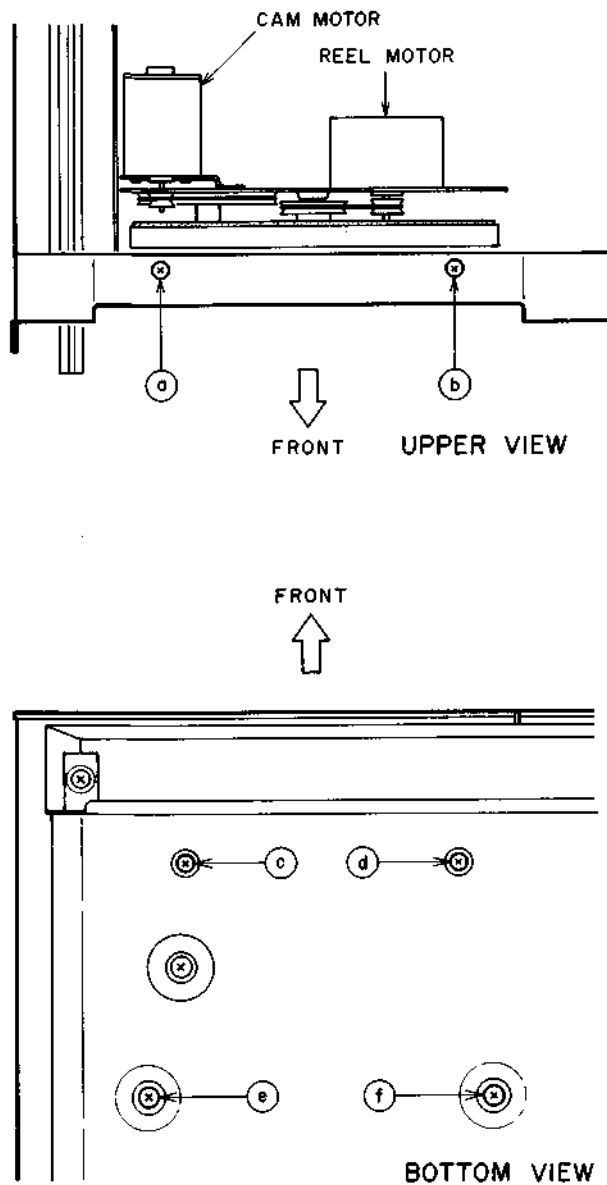

Fig. 5-7

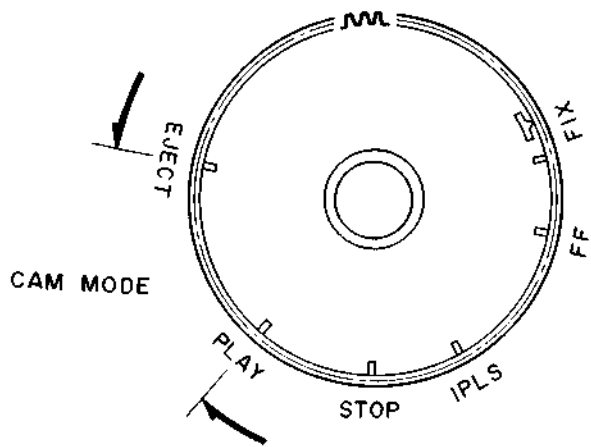

Fig. 5-8

1) LOW VOLTAGE ADJUSTMENT

(Refer to Fig. 5-4 and Fig. 5-5)

- a. With power OFF, remove the connecting cord of the cam motor and turn the operate pulley fully A direction with your fingers.
- b. Connect the digital voltmeter as shown in Fig. 5-4.
- c. With power ON, adjust VR3 so that the voltage reading will be $1.255V \pm 0.05V$.

2) HIGH VOLTAGE ADJUSTMENT

(Refer to Fig. 5-4 and Fig. 5-5)

- a. With power OFF, turn the operate pulley fully B direction with your fingers.
- b. With power ON, adjust VR2 so that the voltage reading will be $9.22V \pm 0.01V$.

3) Repeat Items 1) and 2)

- 4) a. With Power OFF, connect the connecting cord of the motor.
- b. Remove the digital voltmeter.
- c. Remove the screws ① to ⑥ on Fig. 5-6 and pull out the MECHA BLOCK slightly.

- 5) a. Set power to ON.
- b. Adjust VR2 slightly so that center of Mark (A) to center of Mark (B) are coincide at STOP Mode as shown in Fig. 5-6 (STOP Mode voltage is about 7.35V when power supply voltage 9.75V at ① on Fig. 5-4).
- c. Remove the cassette lid and the AUTO SYSTEM switch to IPLS mode.
- d. Confirm that the head does not move up and down when the FF and REW switches are alternately pressed.
- e. Turn the reel with fingers in STOP mode to check that the brake works sufficiently.
When the brake acts normally, the take-up reel does not turn clockwise while the supply reel does not rotate counterclockwise.

5-5 TAPE SPEED ADJUSTMENT (Refer to Fig. 5-9)

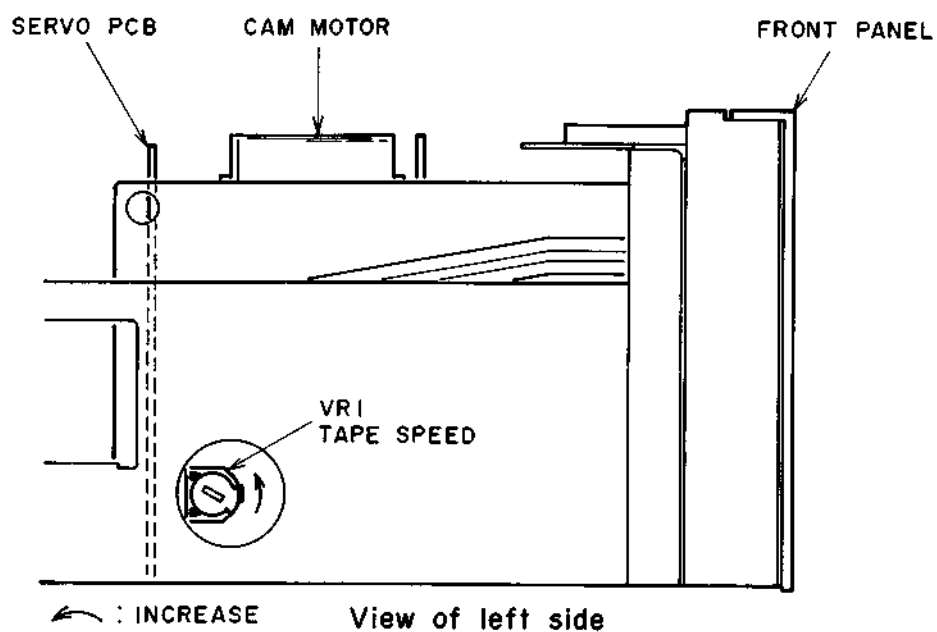

Fig. 5-9

Connect a frequency counter to line output terminals. Playback a 1,000 Hz pre-recorded test tape (AT-750774) and adjust tape speed adjustment volume (SERVO PCB) to obtain a tape speed of 995 Hz to 1005 Hz.

6-1-2 When only Erase Head was replaced (Refer to Figs. 6-1 and 6-2)

- a) Set a 315 Hz or 333 Hz PB Level Adjustment Tape (AT-750773), and select FWD PLAY mode.
- b) Adjust the Erase Head Height by turning the nuts ① & ② shown in Fig. 6-2, so that the Line out level is -5.5 dBm (315 Hz) or -6.1 dBm (333 Hz).
- c) Select REV PLAY mode, and re-adjust the Erase Head Height by turning the nut ③ & ④ so that the difference in level (L-CH) between FWD and REV modes is within ± 0.5 dBm.
- d) Repeat the adjustments in item a), b) and c).
- e) Set a Mirror Cassette Tape (AJ-751178) and select FWD PLAY mode.
- f) Adjust Tape Guide (A) Height by turning the nut (A) and Erase Head (REV) Height by the nut (B) respectively, so that the tape runs smoothly by the adjacent edge of the Erase Head (FWD) without curling.
- g) Next, select REV PLAY mode, and adjust Tape Guide (B) Height by turning the nut (B) so that the tape runs smoothly by the adjacent edges of both Erase Heads (FWD & REV) without curling.
- h) Confirm that the Line output level (L-CH) is -5.5 dBm and the difference in level (L-CH) between FWD and REV modes is within ± 0.5 dBm.

6-2 REC/PB HEAD AZIMUTH ADJUSTMENT (Refer to Fig. 6-2)

Play back a 10 kHz Head Azimuth Adjustment Tape (AT-750778) and adjust the screws ⑤ (FWD direction) and ⑥ (REV direction), so that the levels of both channels are maxima. (Note: Avoid turning the screws too far as other false maxima exist further away on both sides of the correct position.)

6-3 HEAD HEIGHT ADJUSTMENT (Refer to Figs. 6-1 & 6-2)

This adjustment is not necessary since this models GX-R99 is equipped with Rotary Head System (with REC & PB combination head). However, the confirmation of Head Height is necessary and it can be done as follows:

- 1) Confirm the azimuth in item 6-2.
- 2) Playback a 315 Hz (or 333 Hz) PB level Adjustment Tape (AT-750773) in FWD Play mode, and adjust the

PB level Adjuster (VR5 on Pre Amp PCB) so that the LINE OUT level of left channel is -5.5 dBm.

Then, check the level of the same channel in REV mode. The difference in level between FWD and REV modes should be within ± 0.5 dBm

- 3) If the difference is more than ± 0.5 dBm in item 2), adjust the erase heads by turning both Erase Head Height Adjustment screws ⑦ & ⑧ in the same direction by $1/4$ turn (± 0.1 mm), so that difference is within ± 0.5 dBm.
- 4) The Head Height Adjustment is necessary if still the difference could not be corrected by above adjustment. It can be done by changing the Head Height Adjustment Spacers ⑨ & ⑩ (The thicknesses of these spacers are ⑨ = 0.45 mm, ⑩ = 0.35 mm). Loosen the screws ⑪ & ⑫ for the spacer replacement. If the level is lower in REV mode, it means that the head is too high, therefore replace the spacers by thinner ones. When the level is higher in REV mode, replace them by thicker ones. After the replacement of those spacers, do the same adjustment in item 1) and check the level of LINE OUT is -5.5 dBm ± 0.5 dBm. For the further confirmation, playback a 4 Track head Height Adjustment Tape (1 kHz/4 Track, AT-750775). Line Output level of both channels should be more than -8 dBm and the difference in level between FWD and REV modes should be within ± 1 dB. Otherwise do the fine adjustment in the same manner as item 3) & 4).
- 5) When the head replacement is necessary, loosen only the screws ⑬ & ⑭ in Fig. 6-1 for easy replacement.

6-4 HEAD BLOCK PROJECTION ADJUSTMENT

Use a Cassette Head Projection Gauge (AT-751180) and select FWD or REV play mode.

Loosen the screw ⑮ and adjust chassis Head Part ⑯ so that the gauge indication at the time is 3.1 ± 0.15 mm. After the adjustment, apply paint-lock on the screw ⑮.

- NOTES:**
1. Be sure to clean the heads prior to head adjustment.
 2. Be careful not to use a magnetized driver or other magnetized tools in the vicinity of the heads.
 3. Be sure to demagnetize the heads with a Head Demagnetizer before and after head adjustment.

VI. HEAD ADJUSTMENT

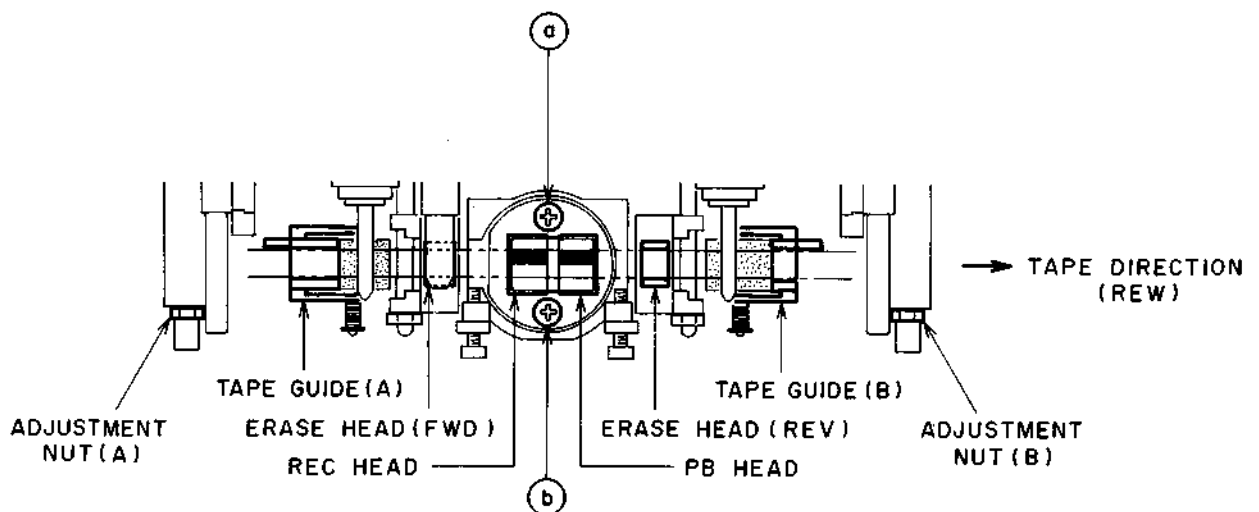

Fig. 6-1

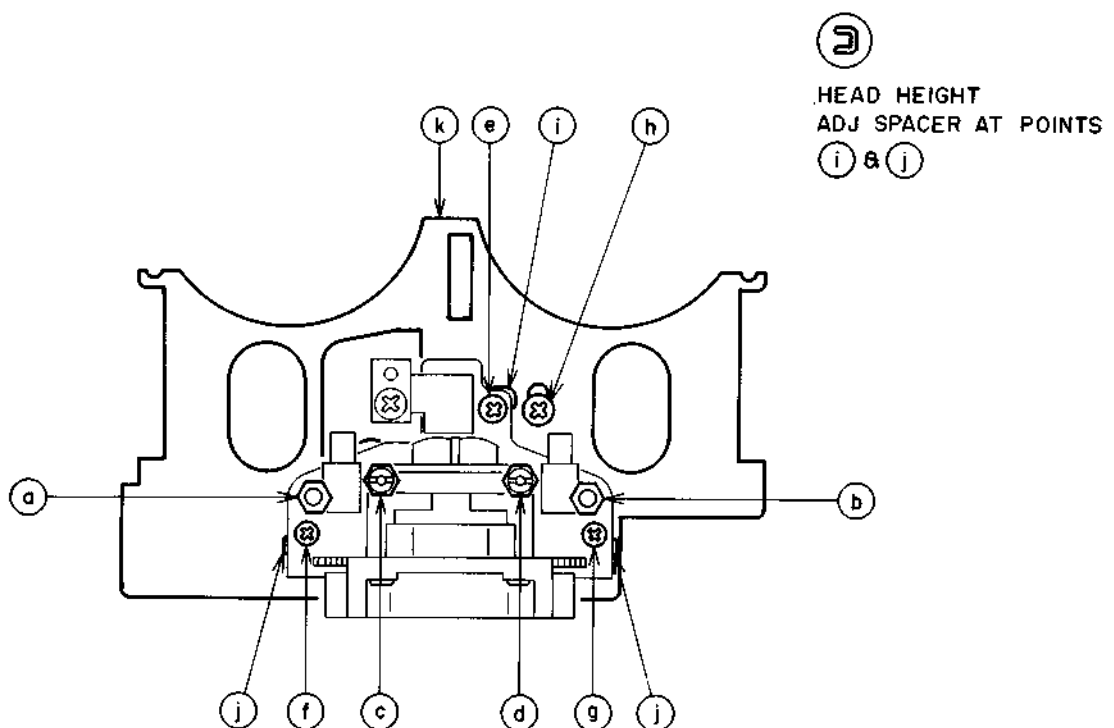

Fig. 6-2

6-1 TAPE GUIDE HEIGHT ADJUSTMENT (Refer to Figs. 6-1 and 6-2)

6-1-1 When Pinch Roller Block was replaced.

- a) Set a Mirror Cassette Tape (AJ-751178)
- b) If only the Pinch Roller Block (L) was replaced, select FWD PLAY mode and adjust Tape Guide (A) Height by turning the nut (A) so that the tape runs smoothly by the adjacent edge of both tape guides, and the tape is not hitched by those tape guides.
- c) If only the Pinch Roller Block (R) was replaced, select REV PLAY mode and adjust Tape Guide (B) Height by turning the nut (B) in the same manner as item b).
- d) Apply paint-lock on those nuts after the adjustment.

7-2 PRE-AMPLIFIER PCB ADJUSTMENT

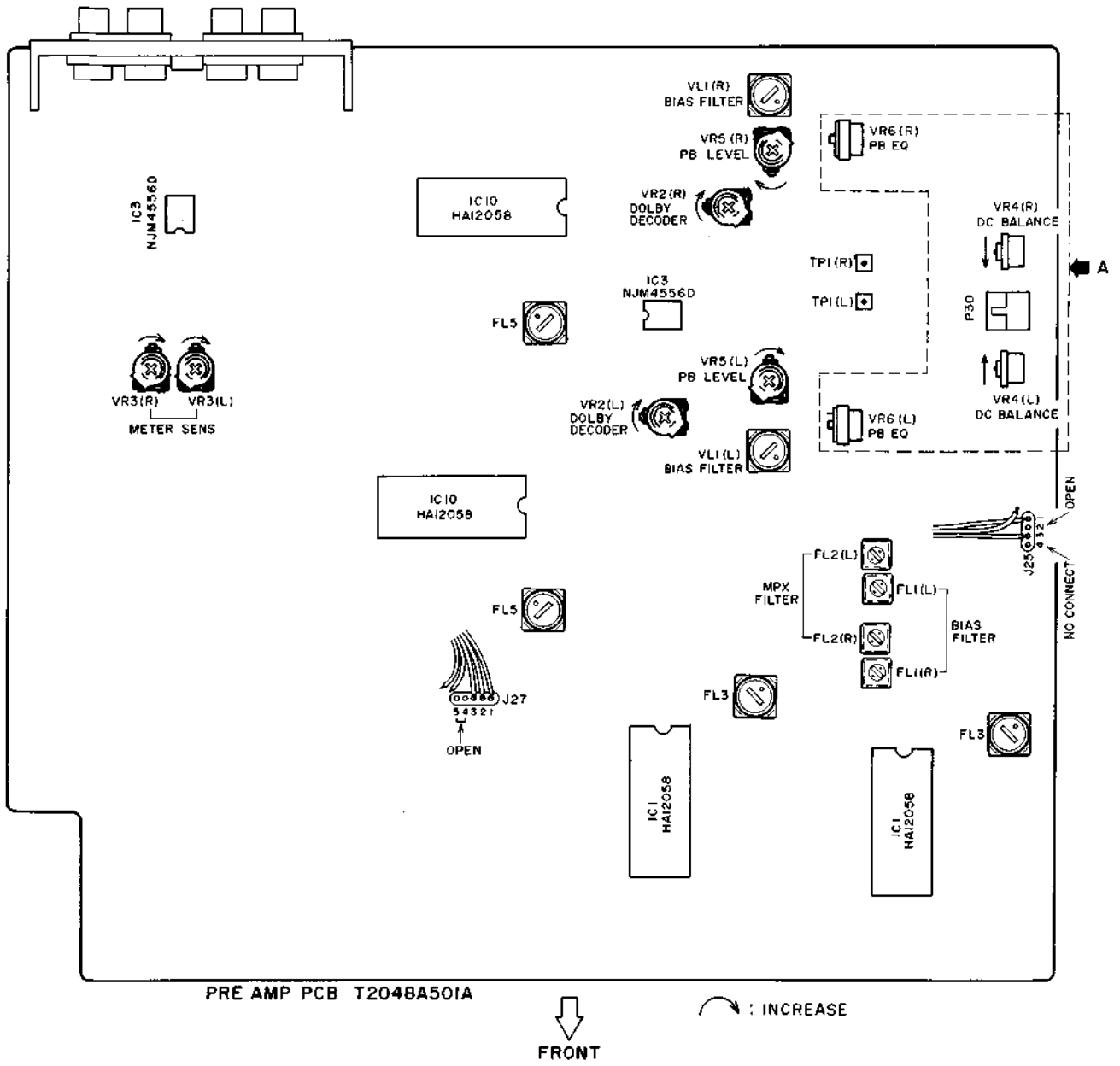

Fig. 7-3 Pre Amp PCB

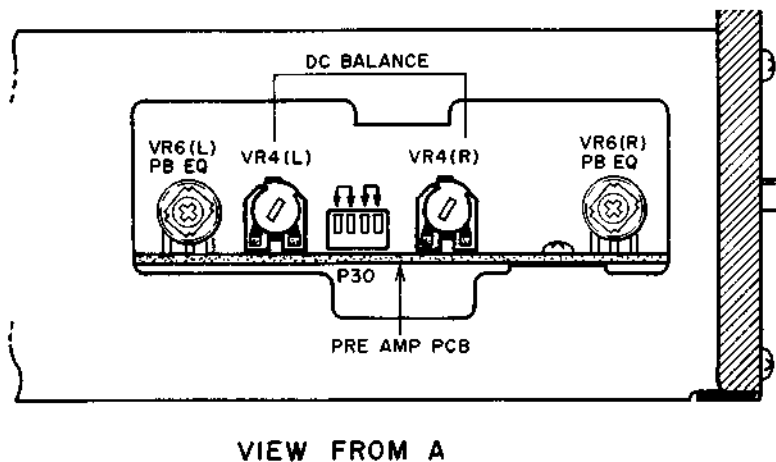

Fig. 7-4

VII. ELECTRICAL ADJUSTMENT

7-1 QUICK REVERSE SENSITIVITY ADJUSTMENT (Refer to Figs. 7-1 & 7-2)

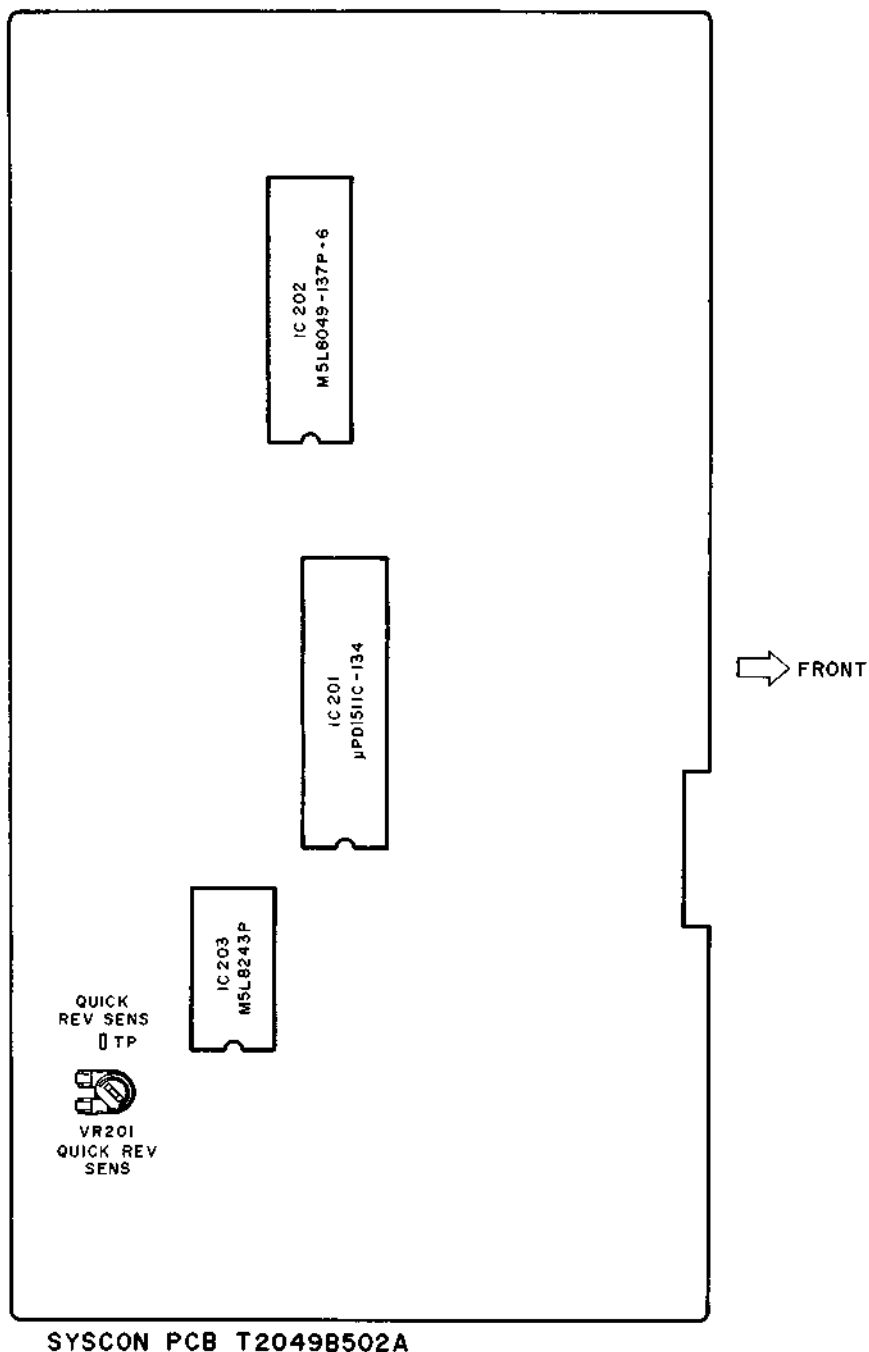

Fig. 7-1 SYS-CON PCB Adjustment Points

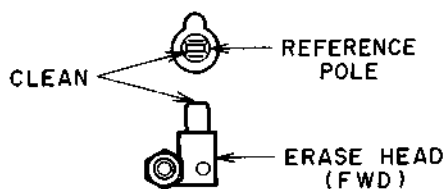

Fig. 7-2

- a) Make a tapeless cassette pack by removing the tape from the cassette pack.
- b) Connect the Digital voltmeter between the Test Point and earth.
- c) Using the tapeless cassette pack, adjust VR201 (on SYS-CON PCB) so that the Digital Voltmeter readings $4.30 \pm 0.05V$ DC at FWD play mode. (TUNING P.C Board is disconnectable from METER P.C Board)

NOTE: Clean the Reference Pole and the Erase Head (FWD side), before this adjustment. (Refer to Fig. 7-2)

PRE AMP ADJUSTMENT CHART (for more detail, see 7-2-1 to 7-2-3)

Step	Adjustment Item	Mode	Test Tape & Supply Signal	Adjustment Point	Result
1	DC Balance	STOP	Connect INPUT PIN of P30 with GND	VR4 (L) VR4 (R)	TP1 (L) TP1 (R) 0 ± 100 mV D.C
2	P.B Level	FWD PLAY	333 Hz 0 VU Tape (315 Hz 0 VU Tape)	VR5 (L) VR5 (R)	LINE OUT -6.1 ± 0.1 dBm $(-5.5 \pm 0.1$ dBm)
		REV PLAY	333 Hz 0 VU Tape (315 Hz 0 VU Tape)	Confirmation	
3	P.B EQ	FWD PLAY	10 kHz P.B EQ Tape	VR6 (L) VR6 (R)	LINE OUT -20.5 ± 0.2 dBm
		REV PLAY	10 kHz P.B EQ Tape	Confirmation	-20.5 ± 2.0 dBm
4	METER Sensitivity	TAPE MONITOR SOURCE	1 kHz LINE IN (-5.2 dBm LINE OUT)	VR3 (L) VR3 (R)	+1 VU indication on VU METER Display
5	Dolby Decoder	FWD PLAY	315 Hz 0 VU Tape (333 Hz 0 VU Tape)	VR2 (L) VR2 (R)	LINE OUT -5.5 ± 0.3 dBm When Dolby ON $(-6.1 \pm 0.3$ dBm)
6	MPX Filter	REC	19 kHz LINE IN	FL2 (L) FL2 (R)	LINE OUT MIN When MPX SW ON
7	BIAS Filter (Source)	REC/PLAY ↓ REC/PAUSE	No Signal Input METAL Tape (REC VR MAX)	FL1 (L) FL1 (R)	LINE OUT MIN
8	BIAS Filter (P.B)	REC/PLAY	No Signal Input METAL Tape	VL1 (L) VL1 (R)	LINE OUT MIN

7-2-1 PB EQ AMP ADJUSTMENT

(TUNING P.C board is disconnectable from METER P.C board)

1) DC Balance

- a. Remove connector of P30 (PB HEAD Connector)
- b. Connect INPUT SIGNAL PIN of P30 Pin ①, ④ to GND.
- c. Adjust VR4 so that the voltage of TP1 will be 0 ± 100 mV DC.

2) PB Level

- a. FWD Play Back 333 Hz (AT-750773) or 315 Hz (AT-750773) PB level adjustment tape and adjust VR5 so that the LINE OUT level will be 333 Hz to -6.1 ± 0.1 dBm or 315 Hz to -5.5 ± 0.1 dBm.
- b. REV Play Back 333 Hz or 315 Hz PB level adjustment tape and confirm so that the LINE OUT level will be -6.1 ± 0.6 dBm (333 Hz) or -5.5 ± 0.6 dBm (315 Hz).

3) PB EQ

- a. FWD Play Back 10 kHz PB EQ adjustment tape (AT-750778) and adjust VR6 so that the LINE OUT level will be -20.5 ± 0.2 dBm.
- b. REV Play Back 10 kHz PB EQ adjustment tape and confirm so that the LINE OUT level will be -20.5 ± 2.0 dBm.

7-2-2 METER SENSITIVITY ADJUSTMENT

- a. With the monitor SW to SOURCE and the meter

SW to VU, Supply 1 kHz to LINE IN, a 1 kHz signal -5.2 dBm at LINE OUT.

- b. Adjust VR3 so that the +1 VU.

7-2-3 DOLBY ADJUSTMENT

1) Dolby Decoder Adjustment

- a. FWD Playback 315 Hz PB level adjustment tape (AT-750773).
- b. Adjust VR2 so that the LINE OUT level will be -5.5 ± 0.3 dBm when Dolby ON. (At 333 Hz PB level adjustment tape, LINE OUT level will be -6.1 ± 0.3 dBm)

2) MPX Filter adjustment

- a. Set a blank tape and set to REC/PLAY mode.
- b. MPX filter SW OFF, input a signal of 19 kHz from LINE IN.
- c. Adjust FL2 so that the LINE OUT level will be at minimum when MPX filter SW is turned ON.

3) BIAS Filter Adjustment

- a. Set a metal tape and set to REC/PLAY (or REC/PLAY → REC/PAUSE).
- b. Adjust FL1 so that the LINE OUT level will be at minimum when the recording volume is set to MAX and the monitor SW to SOURCE.
- c. Set a metal tape and set to REC/PLAY mode.
- d. Adjust VL1 so that the LINE OUT level will be at minimum when the monitor SW is set to TAPE.

7-3 TUNING ADJUSTMENT POINT

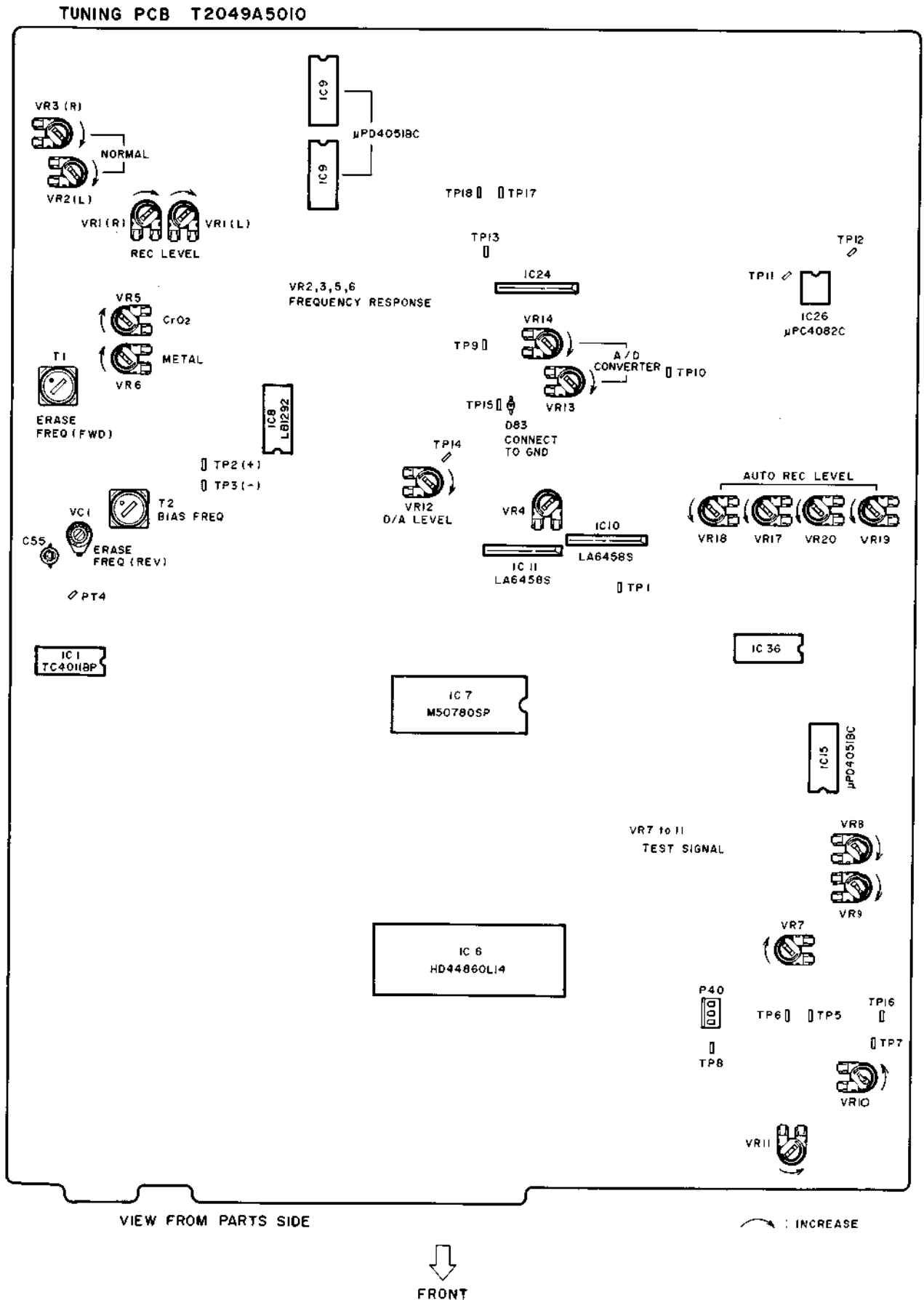

Fig. 7-5 Tuning PCB Adjustment Points

Step	Adjustment Item	Mode	Test Tape Supply Signal	Adjustment Point	Result
4	Test Signal (1K 10K)	Same as Step 3	Connect TP7 and TP16 with GND		LINE OUT 1 kHz
			Connect TP7, TP16 and TP8 with GND	VR10	LINE OUT 10 kHz Same level as 1 kHz
			Connect TP7, TP16 with GND	VR11	LINE OUT -25.5 ± 0.2 dBm
5	REC BIAS OSC	REF Mode FWD/PLAY → REC/PAUSE (In REC II)	METAL Tape	T1	TP4 100 ± 0.2 kHz
		REF Mode REV/PLAY → REC/PAUSE (In REC II)	METAL Tape	VC1	TP4 100 ± 1 kHz (Even if Cutoff C55)
		METAL Tape	T2	Between TP2 (+) and TP3 (-) MIN DC Voltage	
6	Frequency Response (NORMAL)	REF Mode FWD REC/P.B	NORMAL Tape 1 kHz, 10 kHz (-25.5dBm LINE OUT)	VR2 (L) VR3 (R)	LINE OUT 1K, 10K Flat
		REV REC/P.B	Same as FWD		Flat (Confirmation)
	(CrO ₂)	REF Mode FWD REC/P.B	CrO ₂ Tape 1 kHz, 10 kHz (-25.5dBm LINE OUT)	VR5	LINE OUT 1K, 10K Flat
		REV REC/P.B	Same as FWD		Flat (Confirmation)
	(METAL)	REF Mode FWD REC/P.B	METAL Tape 1 kHz, 10 kHz (-25.5dBm LINE OUT)	VR6	LINE OUT 1K, 10K Flat
		REV REC/P.B	Same as FWD		Flat (Confirmation)
7	Recording Level	REF Mode FWD REC/P.B	NORMAL Tape 1 kHz (-5.5dBm LINE OUT)	VR1 (L) VR1 (R)	LINE OUT -5.5 ± 0.2 dBm
		REV REC/P.B	Same as FWD		FWD Result ±0.5 dBm
8	A/D CONVERTER	Unsolder J27 ④ ⑤ Connect TP10, B of TR81 with GND	-5.0 ± 0.2 dBm 1 kHz to TP18	VR14	TP9 +1.5 ± 0.05 V DC
		Open TP10 only	-24.7 ± 0.2 dBm 1 kHz to TP18	VR13	TP9 +2.5 ± 0.05 V DC

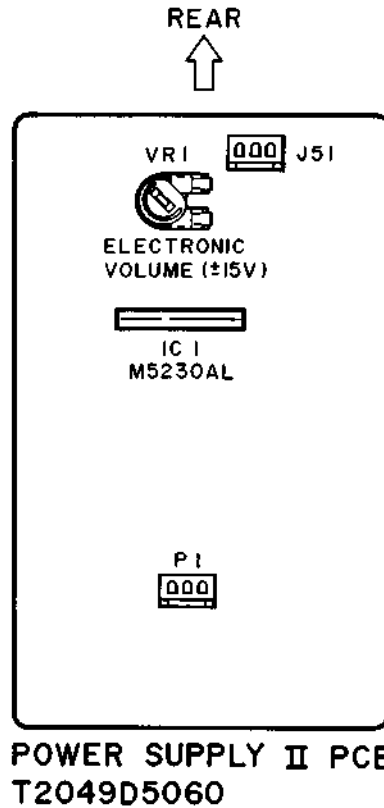

Fig. 7-6 Power Supply II PCB Adjustment Points

TUNING ADJUSTMENT CHART (for more detail see 7-3-1 to 7-3-10)

Step	Adjustment Item	Mode	Test Tape Supply Signal	Adjustment Point	Result
1	D/A Level	CRLP OFF REC VR MAX		VR12	TP14 5.0 ± 0.05 V DC
2	Power Supply (±15V) for VCA	REC VR MAX	1 kHz LINE IN	AUDIO OSC Level	LINE OUT +4.5 dBm
			1 kHz LINE IN	REC VR	+2.08 V DC TP14 } +2.16 V DC
			1 kHz LINE IN	VR1 (On Power Supply II)	LINE OUT -11.5 ± 0.2 dBm
3	Test Signal (400 8K)	Unsolder J27 ④ ⑤ J25 ② (on PRE AMP) REF Mode REC/PAUSE		VR9	LINE OUT 8 kHz -5.5 ± 0.2 dBm
			Connect TP5 and TP6 with GND	VR7	LINE OUT 400 ± 2 Hz
				VR8	LINE OUT -5.5 ± 0.2 dBm
			Connect TP5, TP6 with GND Connect TP16, TP17 directly	VR4	TP1 MIN AC Voltage

- e. Adjust VR7 so that LINE OUT is 400 ± 2 Hz.
- f. Adjust VR8 so that LINE OUT level will be -5.5 ± 0.2 dBm.
- g. Connect TP16 to TP17, adjust VR4 so that the AC voltage to GND of TP1 will be MIN.
- h. Remove short wire in item d and item g.
- i. Connect TP7 and TP16 to GND, LINE OUT is 1 kHz.
- j. Connect TP7 TP16 and TP8 to GND, LINE OUT is 10 kHz.
- k. Adjust VR10 so that level of item i and level of item j will be equal.
- l. Open to TP8 only, adjust VR11 so that LINE OUT level will be -25.5 ± 0.2 dBm.

- *1: For reduce the distortion and the oscillator level differentiation caused by load.
- *2: For cut-off the LINE OUT MUTE.

7-3-6 REC BIAS OSC ADJUSTMENT

- a. In REF mode, set a Metal tape and FWD REC/PAUSE, → FWD PLAY → REC/PAUSE (In REC II mode)
- b. Connect the frequency counter to TP4, adjust T1 so that the frequency will be 100 ± 0.2 kHz.
- c. Set the REV REC/PAUSE mode. (In REC II mode)
- d. Adjust VC1 so that the frequency at TP4 will be 100 ± 1 kHz.
If the proper result could not obtain, cut C55 (120P) and adjust VC1 so that the frequency will be 100 ± 1 kHz.
- e. Connect a DC voltmeter to TP2 (+) and TP3 (-), and adjust T2 so that the DC voltage will be Minimum.

7-3-7 FREQUENCY RESPONSE ADJUSTMENT

- a. In REF mode.
- b. FWD record and playback 1 kHz/10 kHz, -25.5 dBm using a normal tape and adjust VR2 (Lch) and VR3 (Rch) so that 1 kHz will be flat response.
- c. FWD record and playback 1 kHz/10 kHz, -25.5 dBm using a CrO₂ tape and adjust VR5 so that 1 kHz/10 kHz will be flat response.
- d. FWD record and playback 1 kHz/10 kHz, -25.5 dBm using a METAL tape and adjust VR6 so that 1 kHz/10 kHz will be flat response.
- e. Confirm REV mode at 3 type tape mode.

7-3-8 RECORDING LEVEL ADJUSTMENT

- a. In REF mode.
- b. FWD record and playback 1 kHz, -5.5 dBm using

a normal tape, and adjust VR1 so that the difference between recording and playback level will be -5.5 ± 0.2 dBm.

- c. Confirm between FWD and RWD within 0.5 dBm.

7-3-9 A/D CONVERTER ADJUSTMENT

- a. Unsolder the wire connected to J27 ④, ⑤ in PRE AMP PCB. (Refer to Fig. 7-3)
- b. Connect TP10 and cathode of D83 (or base of TR81) with GND.
- c. Input 1 kHz sine wave of -5.0 ± 0.2 dBm to TP18, input signal measured between TP18 and GND.
- d. Adjust VR14 so that the voltage between TP9 and GND will be $+1.5 \pm 0.05$ V DC.
- e. Open TP10.
- f. Input 1 kHz sine wave of -24.7 ± 0.2 dBm to TP18, input signal measured between TP18 and GND.
- g. Adjust VR13 so that the voltage to GND of TP9 will be $+2.5 \pm 0.05$ V DC.

7-3-10 AUTO RECORDING LEVEL ADJUSTMENT

This adjustment adjust alternately input signal Lch/Rch.

- a. Unsolder the wire connected to P27 ④, ⑤ in PRE AMP PCB. (Refer to Fig. 7-3).
- b. Input 400 Hz to LINE IN, and recording volume to MAX.
Adjust Audio Oscillator output volume so that LINE OUT level will be $+4.5 \pm 0.2$ dBm.
- c. Connect TP13 with GND, adjust VR17 (Lch Adjustment) so that the voltage between TP11 and GND will be $+1.5 \pm 0.05$ V DC.
Next adjust VR18 (Rch Adjustment) so that the voltage between TP11 and GND will be $+1.5 \pm 0.05$ V DC.
- d. Input 8 kHz to LINE IN, and recording volume to MAX.
Adjust Audio Oscillator output volume so that LINE OUT level will be $+4.5 \pm 0.2$ dBm.
- e. Connect TP13 with GND, Adjust VR19 (Lch Adjustment) so that the voltage between TP12 and GND will be $+1.5 \pm 0.05$ V DC.
Next adjust VR20 (Rch Adjustment) so that the voltage between TP12 and GND will be $+1.5 \pm 0.05$ V DC.

NOTE: Use the following cassette measuring tapes.

Normal Tape: Maxell UD C-60
CrO₂ Tape: TDK SA C-60
METAL Tape: TDK MA C-60

Step	Adjustment Item	Mode	Test Tape Supply Signal	Adjustment Point	Result
9	Auto Recording Level	REC VR MAX Connect TP13 with GND	400 Hz to LINE IN (L) (+4.5 ± 0.2 dBm LINE OUT)	VR17 (L)	TP11 +1.5 ± 0.05V DC
			400 Hz to LINE IN (R) (+4.5 ± 0.2 dBm LINE OUT)	VR18 (R)	TP11 +1.5 ± 0.05 V DC
			8 kHz to LINE IN (L) (+4.5 ± 0.2 dBm LINE OUT)	VR19 (L)	TP12 +1.5 ± 0.05 V DC
			8 kHz to LINE IN (R) (+4.5 ± 0.2 dBm LINE OUT)	VR20 (R)	TP12 +1.5 ± 0.05 V DC

7-3-1 Reference (REF) mode

- 1) All the adjustments in reference to recording must be carried out in this REF mode.
- 2) How to achieve the REF mode
 - a. Turn on the power and depress EJECT button.
 - b. Turn off the power and insert a SPECIAL METAL cassette tape which has been the CrO₂ (70μ) detection hole is covered with scotch tape. (The METAL detection hole has not been covered) Then REF mode will be achieved automatically 4 seconds after the next power on.

7-3-2 Caution about REF mode

- a. REF mode will be cancelled only when the power is turned off.
- b. In this REF mode, only REC indicator is lit but not TUNING indicator.
If the normal cassette (not the one used in item 7-1) is loaded in this mode, and the power is turned off during REC/PLAY mode only Tuning indicator will be lit at next power on.
Depressing REC/PAUSE button in above condition results both REC & TUNING indicators lit. In those cases, tuning indicator does not mean under tuning but tuning is finished and stand - by for recording.
- c. REC I mode indicates the condition when REC/PAUSE button is depressed at REF mode.
Source signal will be mute and oscillation will be stopped in this REC I mode.
Depressing EJECT button from this mode results no functions even if REC/PAUSE button is depressed.
In such case, depress STOP button then REC/PAUSE button to achieve REC I mode again.
- d. REC II mode can be achieved by depressed PLAY (FWD or REV) button according to the direction indicated on PLAY button at REC I mode.

In the same way, if PLAY button is depressed for a short time, it will not go into REC II REC/PLAY mode directly but go into REC II REC/PAUSE mode.

Therefore depress PLAY button for more than one second, or depress PLAY button once more from that REC II REC/PAUSE mode to achieve REC II REC/PLAY mode.

In this REC II mode, source mute and oscillation mute will be released.

7-3-3 D/A LEVEL ADJUSTMENT

- a. Set the mode CRLP OFF and REC VR is max.
- b. Adjust VR12 so that voltage to GND of TP14 will be 5.0 ± 0.05V DC.

7-3-4 POWER SUPPLY (±15V) OF ELECTRONIC VOLUME ADJUSTMENT (VCA)

- a. Set REC VR to MAX.
- b. Input SINE wave of 1 kHz to LINE IN, adjust Audio Oscillator output volume so that LINE OUT is +4.5 dBm.
- c. Adjust REC VR so that the voltage to GND of TP14 will be +2.08V to +2.16V.
- d. Adjust VR1 (POWER SUPPLY II PCB Refer to Fig. 7-6) so that LINE OUT LEVEL will be -11.5 ± 0.2 dBm.

7-3-5 TEST SIGNAL ADJUSTMENT

- a. Unsolder the wire connected to J27*¹ ④, ⑤ and J25*² ② in PRE AMP PCB (Refer to Fig. 7-3)
- b. In REFERENCE mode, set the mode to REC/PAUSE.
- c. Output 8 kHz signal to LINE OUT, adjust VR9 so that LINE OUT level will be -5.5 ± 0.2 dBm.
- d. When connect TP5 and TP6 to GND, LINE OUT is near 400 Hz.

VIII. DC RESISTANCE OF VARIOUS COILS

Parts		Name	DC Resistance
REC / PB HEAD	H901	RP4-10	30 Ohms (REC) 305 Ohms (PB)
ERASE HEAD	H902	E4-11	3.7 Ohms
ERASE HEAD	H903	E4-11S	
DOOR MOTOR	M905	EF-2805	20 Ohms
CAM MOTOR	M904		
REEL MOTOR	M903	RF-510T	34 Ohms
CAPSTAN MOTOR	M901 M902		85 Ohms \pm 5% L ₁ , L ₂ L ₃ , L ₄

IX. CLASSIFICATION OF VARIOUS P.C BOARDS

9-1 P.C BOARD TITLES AND IDENTIFICATION NUMBERS

P.C Board Title		P.C Board Number
TUNING	P.C BOARD	T2049A5010
PRE AMP	P.C BOARD	T2048A501A
OUT VOLUME	P.C BOARD	T2048A501D
SWITCH	P.C BOARD	T2048A5010C
HEAD PHONE	P.C BOARD	T2048A501B
COIL	P.C BOARD	T2048A501F
COIL	P.C BOARD	T2048A501G
SYSTEM CONTROL	P.C BOARD	T2049B502A
POWER SUPPLY	P.C BOARD	T2048B5031 U
		T2048B5030 J
		T2048B5032 C A
		T2048B5033 E V S B
FILTER	P.C BOARD	M3105B501E
POWER SUPPLY II	P.C BOARD	T2049D5060
METER	P.C BOARD	T2049B5040
REC	P.C BOARD	T2049B503A
SERVO	P.C BOARD	M3105B501B
POTENTION	P.C BOARD	M3105B501C
CONNECTOR A	P.C BOARD	M3105B501D
CONNECTOR B	P.C BOARD	T2049B502D
MOTOR	P.C BOARD (CAPSTAN)	M3105B501A
FG	P.C BOARD	M3105C5020
MOTOR	P.C BOARD (DOOR)	T2049B503B
REMOTE CONTROL	P.C BOARD	T2049B502C
SWITCH	P.C BOARD (DOOR)	T2049B503C
HOLDER LEAF SW	P.C BOARD	CMR02C5010
FLEXIBLE	P.C BOARD	CHR02A5050
DETECTOR (L)	P.C BOARD	CMR02D5040
DETECTOR (R)	P.C BOARD	CMR02D5030
LED	P.C BOARD	CMR02D5020

9-2 COMPOSITION OF VARIOUS P.C BOARDS

1) TUNING P.C BOARD T2049A5010

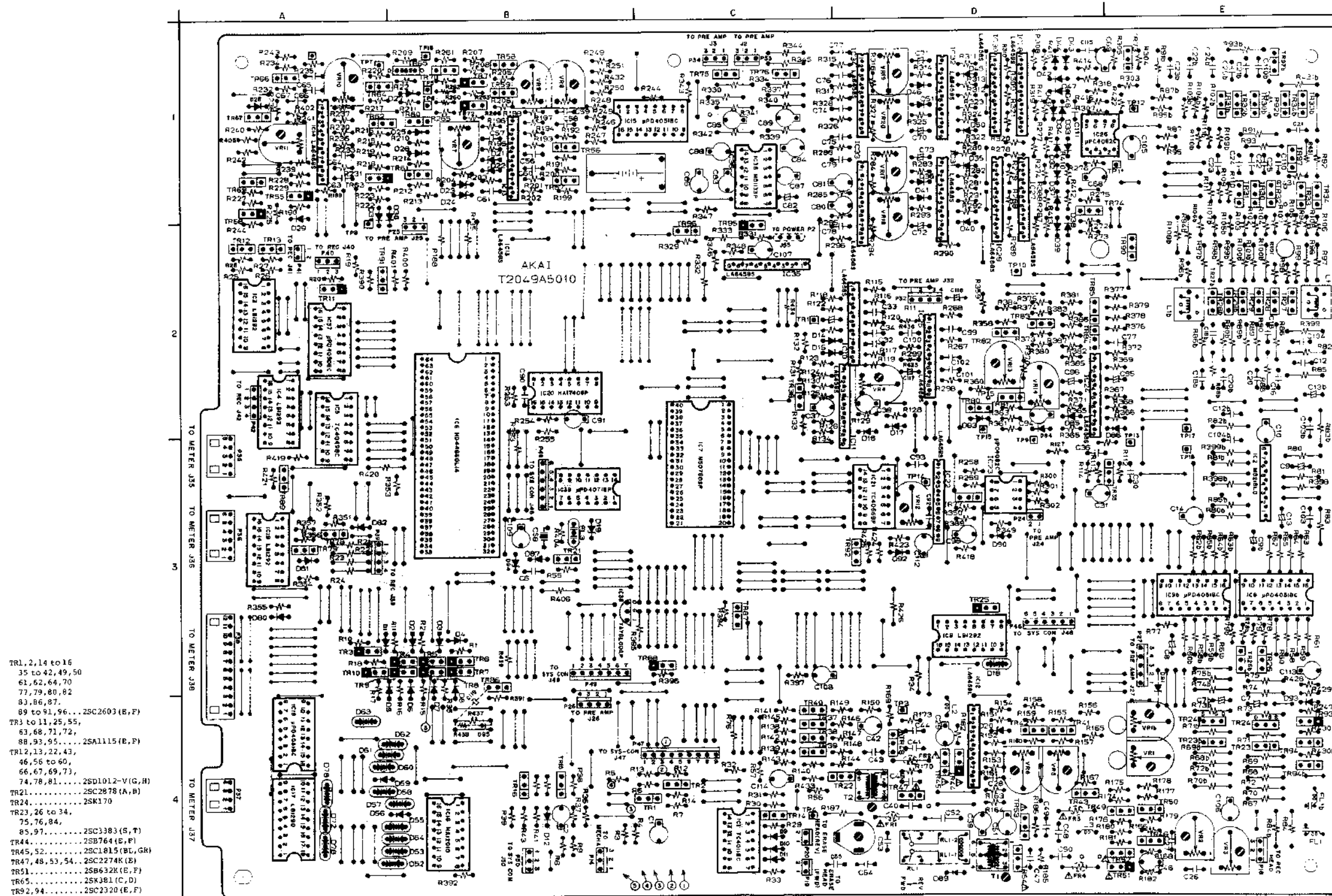

- TR1, 2, 14 to 16
- 35 to 42, 49, 50
- 61, 62, 64, 70
- 71, 79, 80, 82
- 83, 86, 87
- 89 to 91, 96...25C2603 (E, F)
- TR3 to 11, 25, 55,
- 63, 68, 71, 72,
- 88, 93, 95...25A1115 (E, F)
- TR12, 13, 22, 43,
- 46, 56 to 60,
- 66, 67, 69, 73,
- 74, 78, 81...25D1012-V (G, H)
- TR21...25C2878 (A, B)
- TR24...25K170
- TR23, 26 to 34,
- 75, 76, 84,
- 85, 97...25C3383 (E, F)
- TR44...25B764 (E, F)
- TR45, 52...25C1815 (BL, GR)
- TR47, 48, 53, 54...25C2274 (E)
- TR51...25B632K (E, F)
- TR65...25K381 (C, D)
- TR92, 94...25C2320 (E, F)

- TUNING PCB T2049A5010**
- VR1...REC LEVEL Lch
 - VR1b...REC LEVEL Rch
 - VR2...FREQ RESPONSE(NORMAL) Lch
 - VR3...FREQ RESPONSE(NORMAL) Rch
 - VR4...TEST SIGNAL(NML DISTORTION)
 - VR5...FREQ RESPONSE(CR2)
 - VR6...FREQ RESPONSE(METAL)
 - VR7...TEST SIGNAL(400Hz LEVEL)
 - VR8...TEST SIGNAL(400Hz LEVEL)
 - VR9...TEST SIGNAL(8kHz LEVEL)
 - VR10...TEST SIGNAL(1K/10K BALANCE)
 - VR11...TEST SIGNAL(1K/10K LEVEL)
 - VR12...D/A CONVERTER LEVEL
 - VR13...A/D CONVERTER(1K/10K SET)
 - VR14...A/D CONVERTER
 - (MML, MOL RECTIFICATION LEVEL SET)
 - VR17...AUTO REC LEVEL(MML LEVEL) Lch
 - VR18...AUTO REC LEVEL(MML LEVEL) Rch
 - VR19...AUTO REC LEVEL(MOL LEVEL) Lch
 - VR20...AUTO REC LEVEL(MOL LEVEL) Rch
 - T1...ERASE FREQ(FWD)
 - T2...BIAS FREQ
 - VC1...FRASE FREQ(REV)

WARNING: Δ INDICATES SAFETY CRITICAL COMPONENTS FOR CONTINUED SAFETY. REPLACE SAFETY CRITICAL COMPONENTS ONLY WITH MANUFACTURER'S RECOMMENDED PARTS.

AVERTISSEMENT: Δ IL INDIQUE LES COMPOSANTS CRITIQUES DE SÉCURITÉ. REMPLACEZ LE DEGRÉ DE SÉCURITÉ DE L'APPAREIL SEULEMENT AVEC DES PIÈCES RECOMMANDÉES PAR LE FABRICANT.

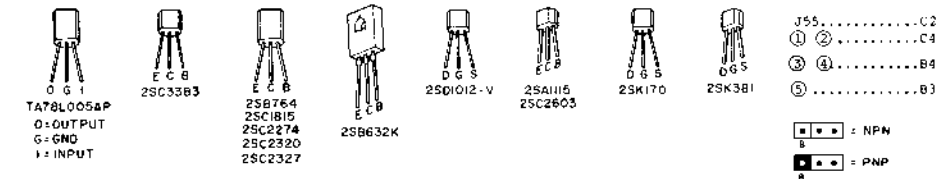

LOCATION OF COMPONENTS

IC	
IC1C4
IC2E3
IC3 to 5A2
IC6B3
IC7C3
IC8D3
IC9, 9bE3
IC10, 11D2
IC12D4
IC13B1
IC14A1
IC15C1
IC16B4
IC17, 18A4
IC19A3
IC20B2
IC21 to 23D3
IC24, 25D2
IC26B1
IC27 to 34D1
IC35C2
IC36C1
IC37A2
IC38, 39B3
TR	
TR1, 2C4
TR3A3
TR4 to 9B3
TR10A3
TR11 to 13A2
TR14C4
TR15, 16B4
TR21B3
TR22D4
TR23, 23bE4
24, 24bE4
TR25D3
TR26, 26bE3
TR27 to 29E3
27b to 29bE2
TR30 to 34E1
30b to 34bE1
TR35D3
TR36C2
TR37 to 40C4
TR41 to 45D4
TR46E4
TR47, 48D4
TR49 to 52E4
TR53, 54D4
TR55A1
TR56 to 61B1
TR62 to 64A1
TR65B1
TR66 to 69A1
TR70 to 72B1
TR73E1
TR74D1
TR75, 76C1
TR77D3
TR78, 79A3
TR80 to 85D2
TR86B3
TR87, 88C3
TR89A3
TR90E2
TR91B2
TR92D3
TR93, 94, 94bE4
TR95, 96C2
TR97, 97bE1
TERMINAL	
P14B4
P18E4
P19C4
P20C4
P24D3
P25B2
P26B4
P27E4
P33C1
P34C1
P35A3
P36A3
P37A4
P38A3
P39A3
P40A2
P41A2
P42A2
P43D2
P46D3
P47C4
P48B3
P49D3
P50B4

2) PRE AMP P.C BOARD T2048A501A, OUT VOLUME P.C BOARD T2048A501D, SWITCH P.C BOARD T2048A501C, HEADPHONE P.C BOARD T2048A501B
 COIL P.C BOARD T2048A501F, COIL P.C BOARD T2048A501G

LOCATION OF COMPONENTS

- IC'S E4
 IC1 E5
 IC2 C4
 IC3 A1
 IC4 B1
 IC5 C1
 IC6 D1
 IC7 B1
 IC8 D1
 IC9 B4
 IC10 C3
 IC10A A3

- TRANSISTORS E2
 TR1 C5
 TR2 D5
 TR3 B2
 TR4 E2
 TR5 D2
 TR6 D4
 TR7 A4
 TR8 E3
 TR9 C3
 TR10 D3
 TR10A D3
 TR11 E3
 TR11A E3
 TR12 E2
 TR13 E7
 TR14 D2
 TR15 D2
 TR16 D2
 TR17 E2
 TR18 E2
 TR19 E2
 TR20 C1
 TR20A C1
 TR21 D1
 TR21A D1
 TR22 D1
 TR22A D1
 TR23 E1
 TR23A E1
 TR24 E1
 TR25 E1
 TR26 E1
 TR27 E1
 TR28 B5
 TR28A B5
 TR29 B5
 TR29A B5
 TR30 B5
 TR30A B5
 TR31 B4
 TR31A B4
 TR32 B4
 TR32A B4
 TR33 B4
 TR33A B4
 TR34 A4
 TR34A A4
 TR35 C4
 TR35A C4
 TR36 B4
 TR36A B4
 TR37 A4

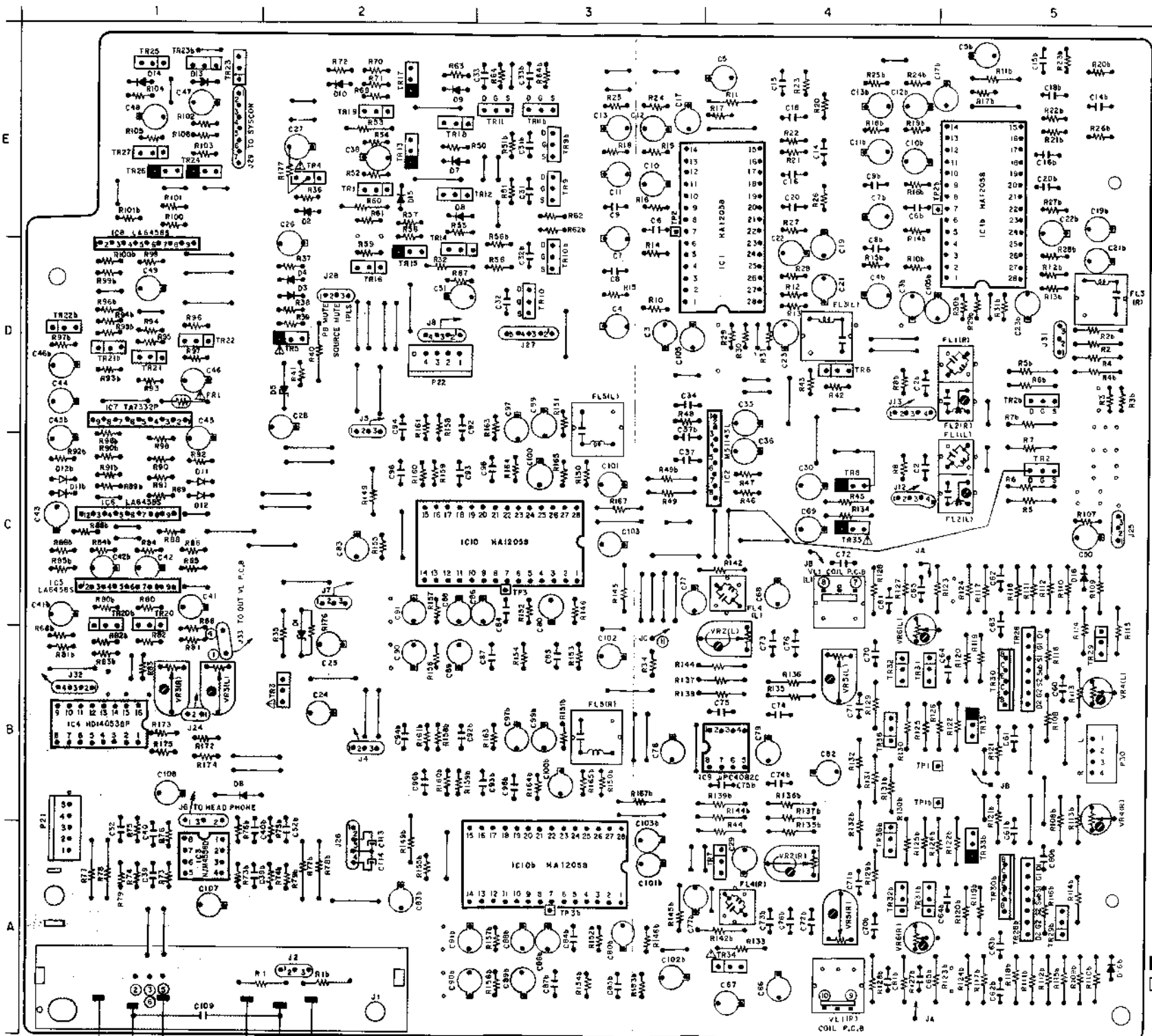
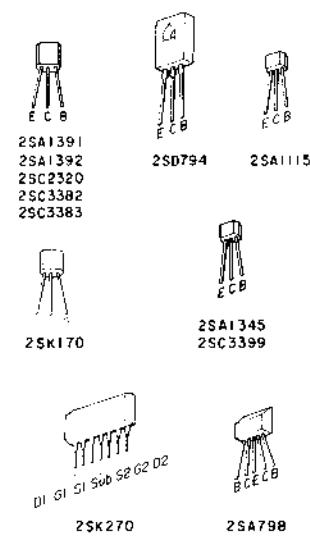

- TR1, 4, 6, 16, 19, 20 to 22
 27, 36 ----- 2SC2320(F,G)
- TR2 ----- 2SK117(BL,GR)
- TR3 ----- 2SD794(P,O)
- TR5 ----- 2SA1115(F,G)
- TR7, 14, 29 ----- 2SC3383(S,T)
- TR8 ----- 2SA1392(S,T)
- TR9 to 11 ----- 2SK170(BL,GR)
- TR12, 18, 23, 25 ----- 2SC3399
- TR13, 15, 17, 24, 26 ----- 2SA1345
- TR20 ----- 2SK270(BL,GR)
- TR28 ----- 2SA798(F,G)
- TR31, 32, 34 ----- 2SC3382(S,T)
- TR33, 35 ----- 2SA1391(S,T)
- FL1(L), FL1(R), VL1(L), VL1(R) ---BIAS FILTER
 FL2(L), FL2(R) -----MPX FILTER
- VR2(L), VR2(R) --- DOLBY DECODER
 VR3(L), VR3(R) --- METER SENS
 VR4(L), VR4(R) --- DC BALANCE
 VR5(L), VR5(R) --- PB LEVEL
 VR6(L), VR6(R) --- PB EQ

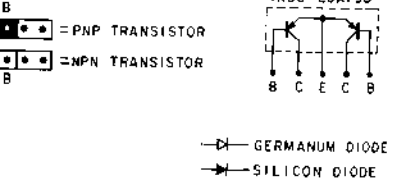

OUT VOLUME PCB T2048A501D

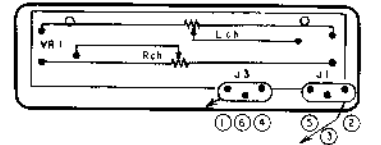

SWITCH PCB T2048A501C

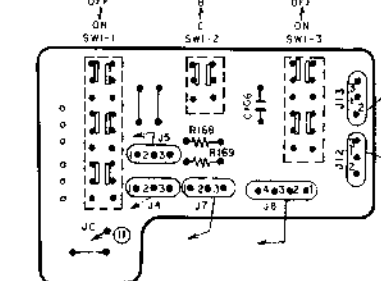

HEAD PHONE PCB T2048A501B

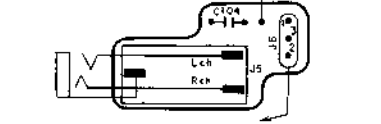

COIL PCB T2048A501F

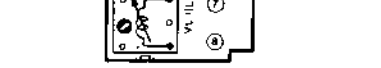

COIL PCB T2048A501G

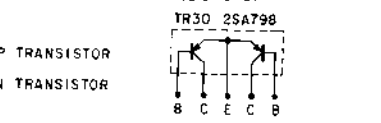
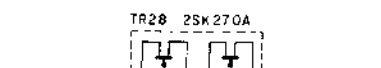

WARNING ΔINDICATES SAFETY CRITICAL COMPONENTS FOR CONTINUED SAFETY. REPLACE SAFETY CRITICAL COMPONENTS ONLY WITH MANUFACTURER'S RECOMMENDED PARTS
 AVERTISSEMENT ΔIL INDIQU LES COMPOSANTS CRITIQUES DE SÛRETÉ. POUR MAINTENIR LE DEGRÉ DE SÛRETÉ DE L'APPAREIL NE REMPLACER LES COMPOSANTS DONT LE FONCTIONNEMENT EST CRITIQUE POUR LA SÛRETÉ QUE PAR DES PIÈCES RECOMMANDÉES PAR LE FABRICANT

3) SYSCON P.C BOARD T2049B502A

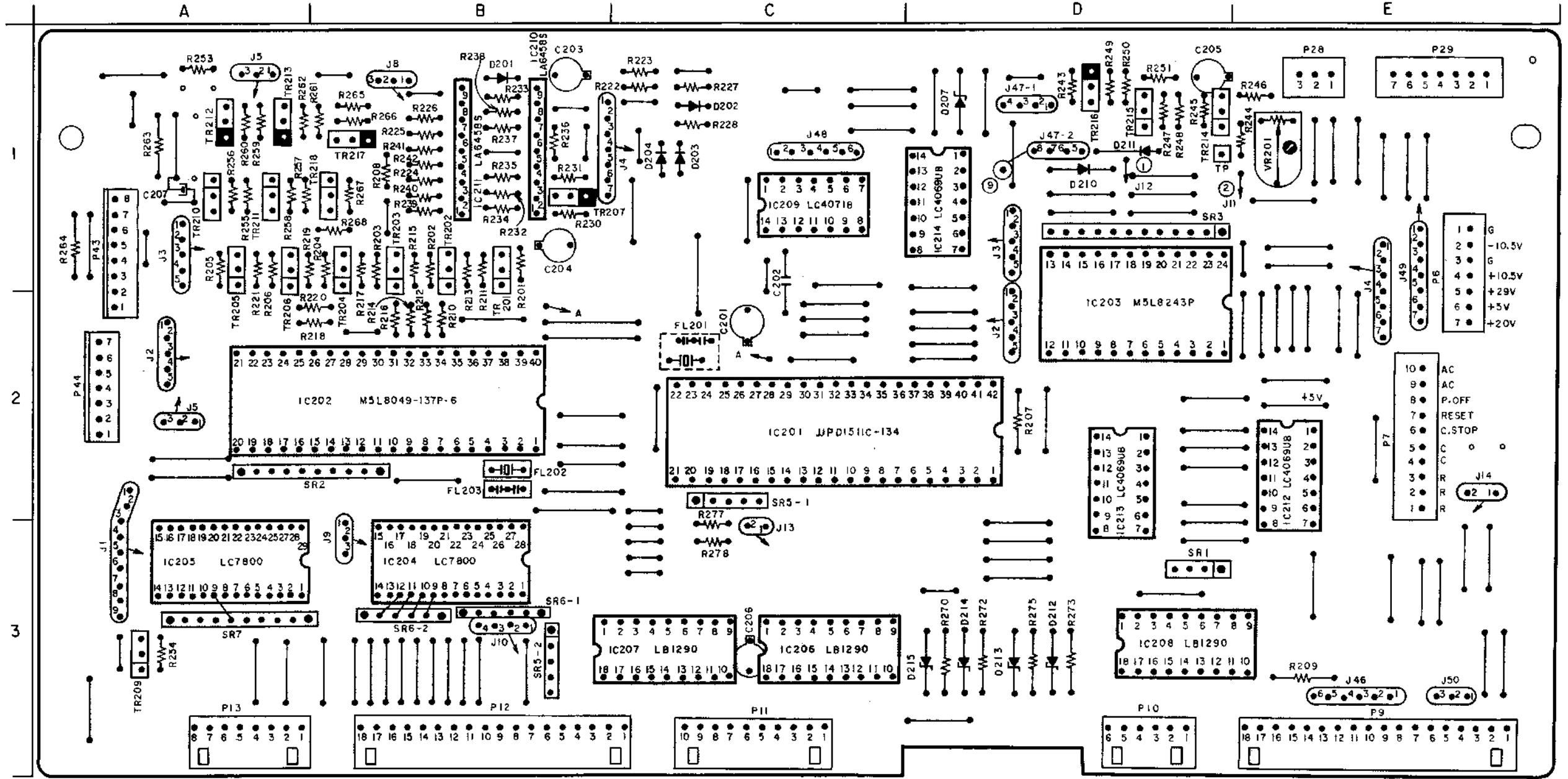

SYSCON PCB T2049B502A

TR201 to 206, 210, 211 --- 2SD1012 (F, G, H)
 TR207 --- 2SA733 (A) (P, Q)
 TR209, 214, 215 --- 2SC2603 (E, F)
 TR212, 213 --- 2SB808 (F, G, H)
 TR216 --- 2SA1115 (E, F)

VR201 --- QUIC REV SENS.

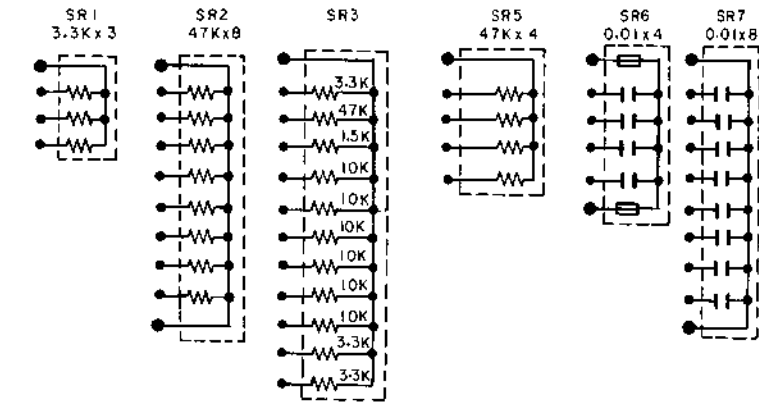
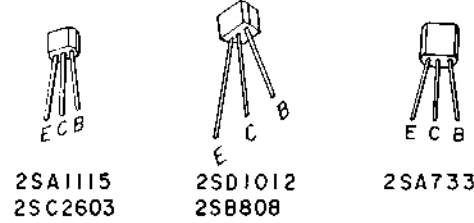
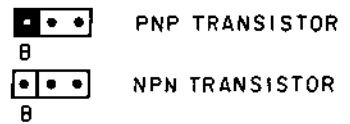

LOCATION OF COMPONENTS

IC'S	
IC201	C2
IC202	B2
IC203	D2
IC204	B3
IC205	A3
IC206	C3
IC207	C3
IC208	D3
IC209	C1
IC210	B1
IC211	B1
IC212	E2
IC213	D2
IC214	D1

TRANSISTORS

TR201	B1	TR211	A1
TR202	B1	TR212	A1
TR203	B1	TR213	A1
TR204	B1	TR214	D1
TR205	A1	TR215	D1
TR206	A1	TR216	D1
TR207	B1	TR217	B1
TR209	A3	TR218	B1
TR210	A1		

TERMINALS

J1	A3	P6	E1
J8	B1	P7	E2
J9	B3	P9	E3
J10	B3	P10	D3
J13	C3	P11	C3
J14	E2	P12	B3
J46	E3	P13	A3
J47	D1	P28	E1
J48	C1	P29	E1
J49	E1	P43	A1
J50	E3	P44	A2

4) POWER SUPPLY P.C BOARD T2048B5030 **J**, T2048B5031 **U**, T2048B5032 **C A**, T2048B5033 **E V S B**
 FILTER P.C BOARD M3105B501E

* F1a3	F4	F5	* C30
U 250V 1A	250V 1.6A		U 0.022 (M) 250AC
J 250V 1A	250V 1.6A	250V 0.63A	J 0.022 (M) 2500C
C, A 125V 1A	125V 1.6A	125V 0.63A	C, A 0.022 (M) 125AC
E, V, B, S T1A	T1A	T1A	E, V, B, S 0.022 (M) 250AC

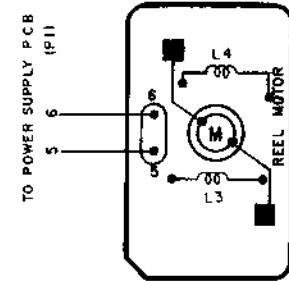
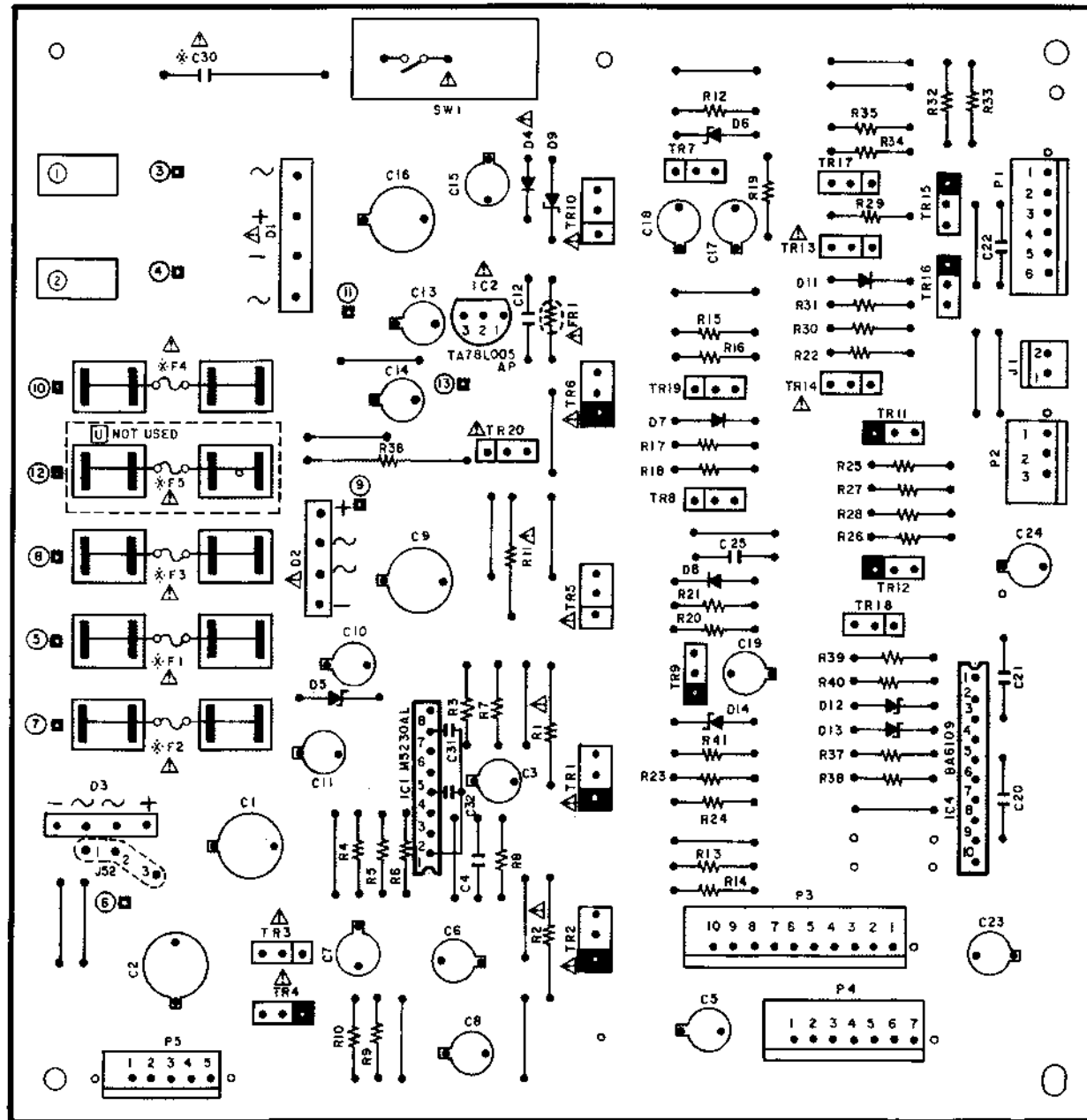

**FILTER PCB
M3105B501E**

- TR1-----2SB744 (P,Q)
- TR2-----2SD794 (P,Q)
- TR3-----2SC2320 (E,F)
- TR4-----2SA999 (E,F)
- TR5-----2SD549 (E,F)
- TR6-----2SB632K (E,F)
- TR7,8,17,19,20--2SC2603 (E,F)
- TR9-----2SA733A (P,Q)
- TR10-----2SD612K (F)
- TR11,12,15,16--2SB808V (G,H)
- TR13,14,18----2SD1012V (G)

- = PNP TRANSISTOR
- = NPN TRANSISTOR
- = SILICON DIODE
- = GERMANIUM DIODE

- POWER SUPPLY PCB**
 T2048B5030 **J**
 T2048B5031 **U**
 T2048B5032 **C A**
 T2048B5033 **E V S B**

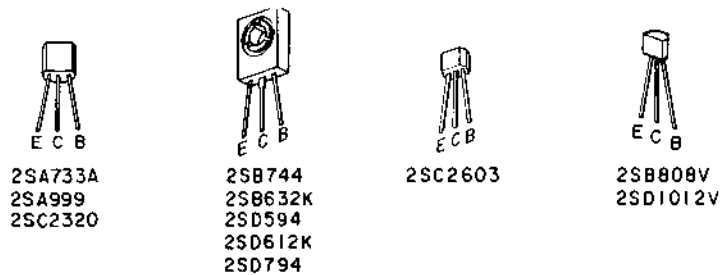

WARNING: Δ INDICATES SAFETY CRITICAL COMPONENTS. FOR CONTINUED SAFETY, REPLACE SAFETY CRITICAL COMPONENTS ONLY WITH MANUFACTURER'S RECOMMENDED PARTS.
 AVERTISSEMENT: Δ IL INDIQUE LES COMPOSANTS CRITIQUES DE SÉCURITÉ. POUR MAINTENIR LE DEGRÉ DE SÉCURITÉ DE L'APPAREIL, NE REMPLACER QUE DES PIÈCES RECOMMANDÉES PAR LE FABRICANT.

5) POWER SUPPLY II P.C BOARD T2049D5060

- TR1-----2SA1345
- VR1-----ELECTRONIC VOLUME ($\pm 15V$)

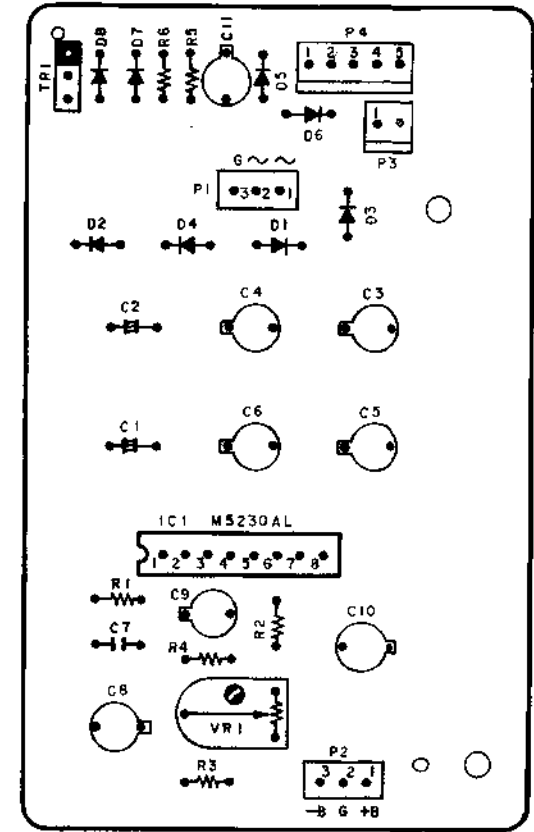
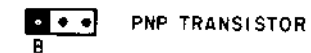

**POWER SUPPLY II PCB
T2049D5060**

6) METER P.C BOARD T2049B5040

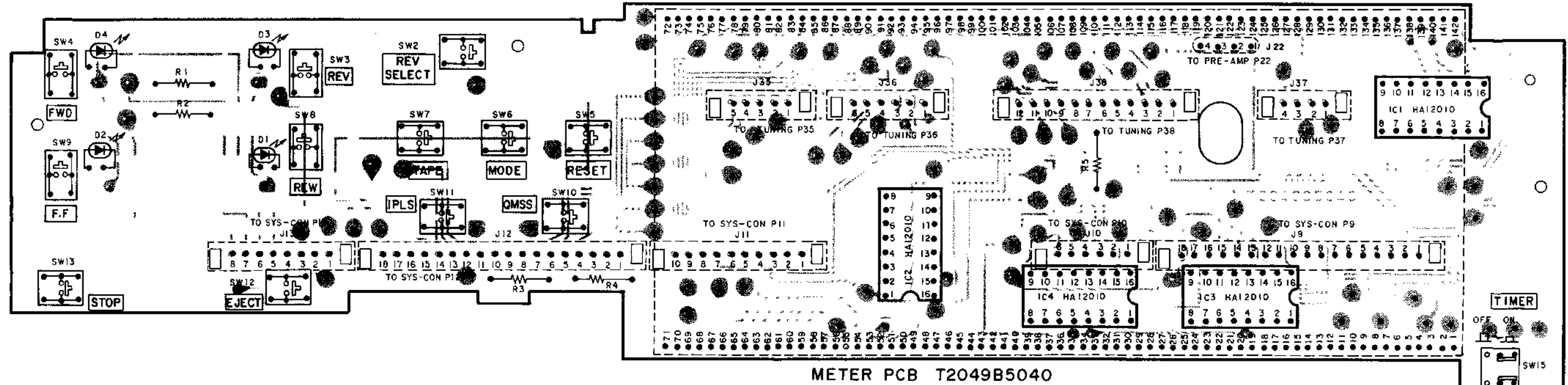

7) REC P.C BOARD T2049B503A

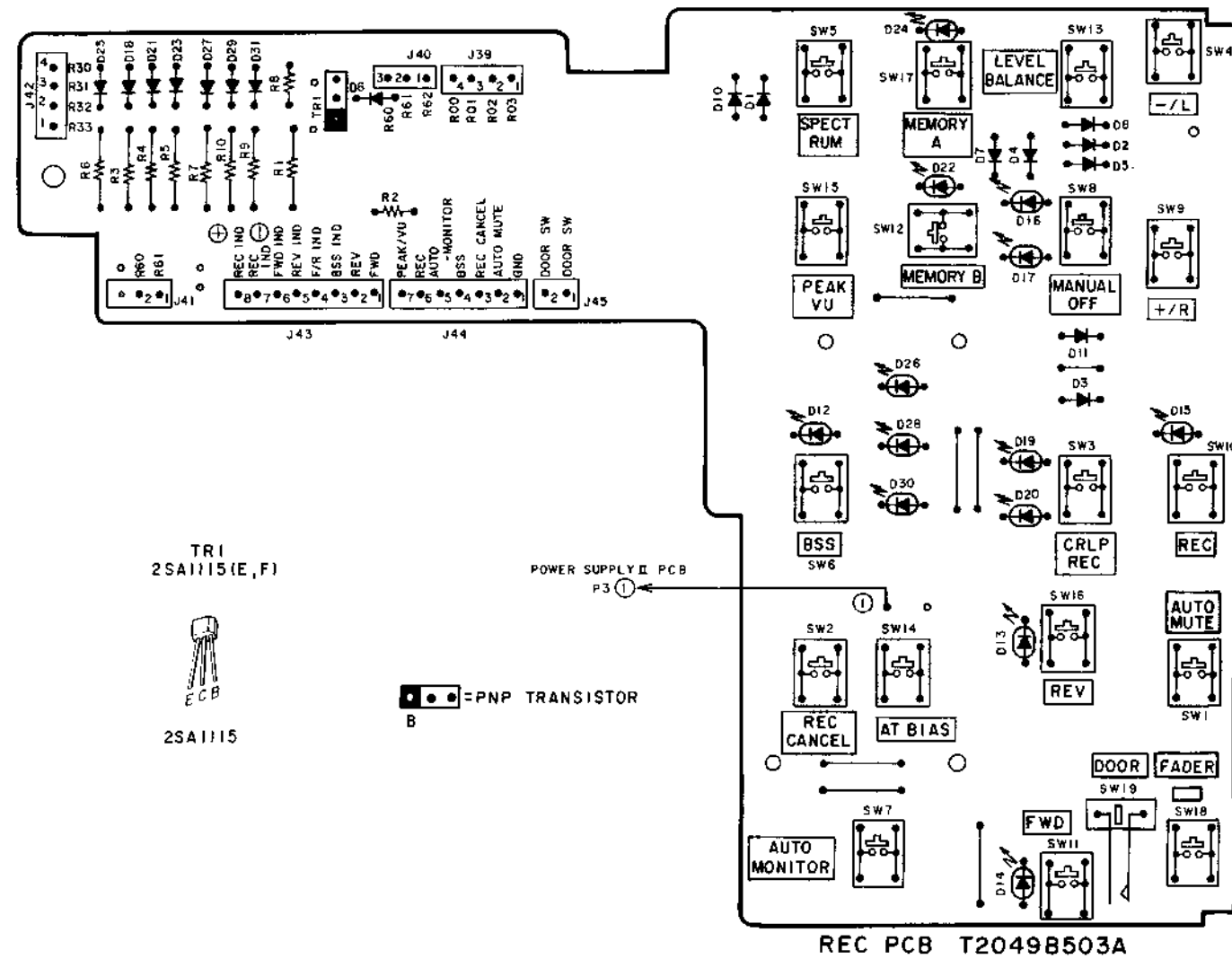

8) SERVO P.C BOARD M3105B501B, CONNECTOR A P.C BOARD M3105B501D,
CONNECTOR B P.C BOARD T2049B502D, POTENTION P.C BOARD M3105B501C

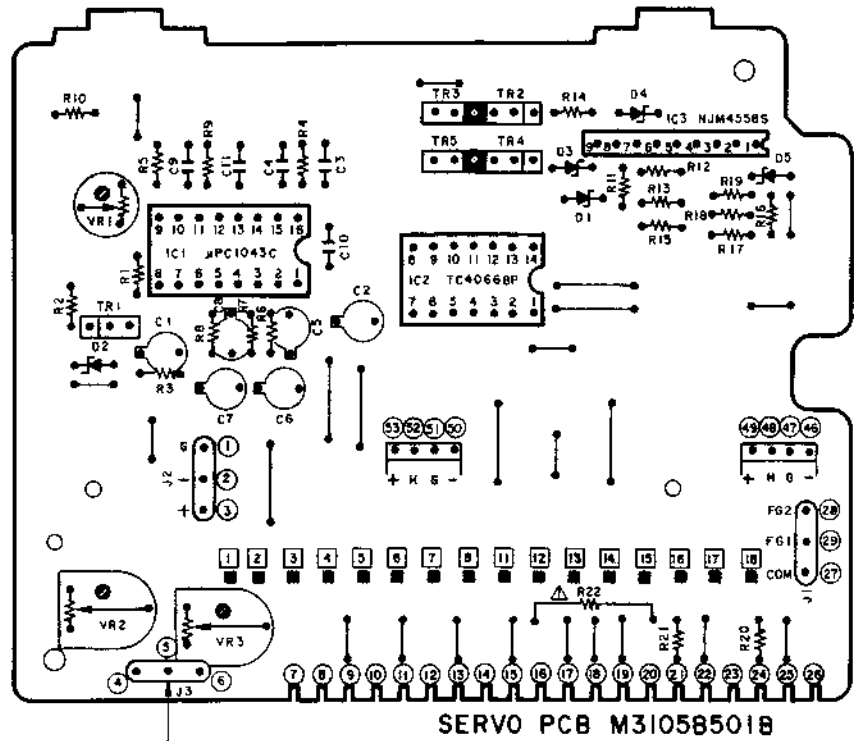

TR1-----2SC2603(E,F)
TR2,4----2SC2274K(D,E)
TR3,5----2SA984K(D,E)

VR1-----TAPE SPEED
ADJUSTMENT
VR2-----HIGH VOLTAGE
ADJUSTMENT
VR3-----LOW VOLTAGE
ADJUSTMENT

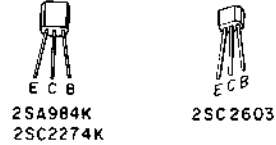

● NPN TRANSISTOR
▲ PNP TRANSISTOR

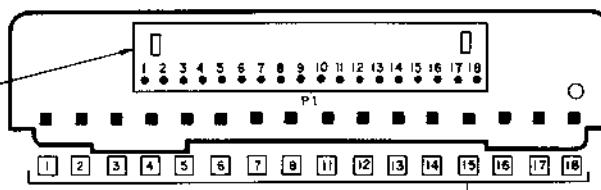
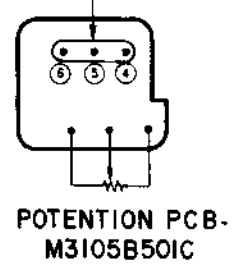

CONNECTOR A PCB
M3105B501D

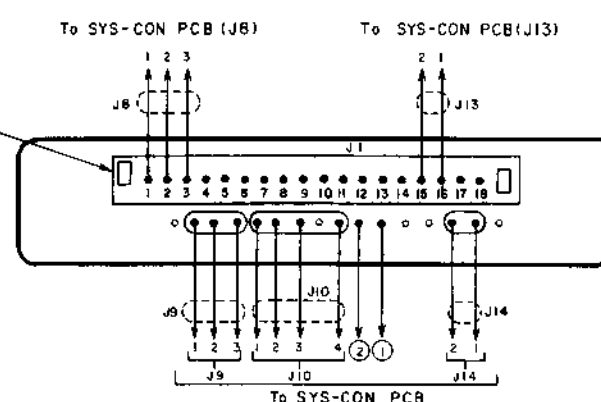

CONNECTOR B PCB
T2049B502D

WARNING: Δ INDICATES SAFETY CRITICAL COMPONENTS. FOR CONTINUED SAFETY, REPLACE SAFETY CRITICAL COMPONENTS ONLY WITH MANUFACTURER'S RECOMMENDED PARTS.
AVERTISSEMENT: Δ IL INDIQUE LES COMPOSANTS CRITIQUES DE SÉCURITÉ. POUR MAINTENIR LE DEGRÉ DE SÉCURITÉ DE L'APPAREIL, NE REMPLACER QUE DES PIÈCES RECOMMANDÉES PAR LE FABRICANT.

9) MOTOR P.C BOARD M3105B501A, FG P.C BOARD M3105C5020

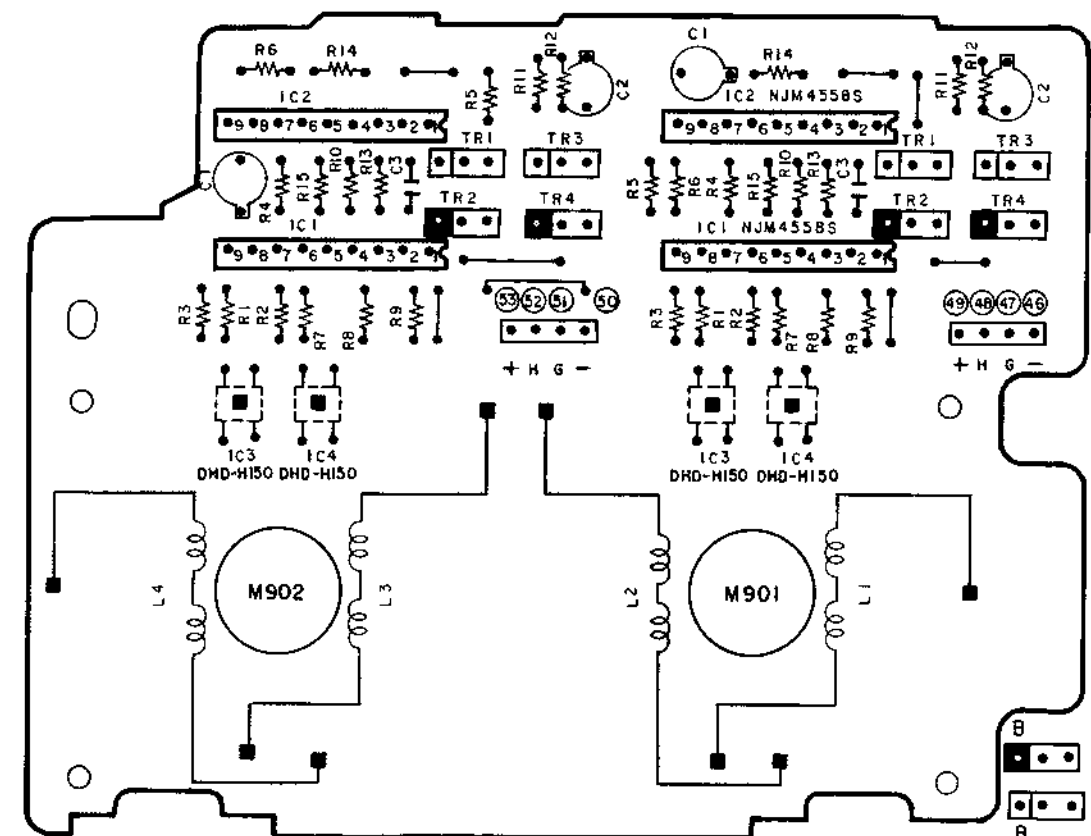

TR1,3
--2SC2274K(D,E)
TR2,4
2SA984K(D,E)

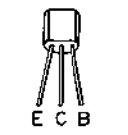

2SC2274K
2SA984K

PNP TRANSISTOR
NPN TRANSISTOR

(CAPSTAN) MOTOR PCB M3105B501A

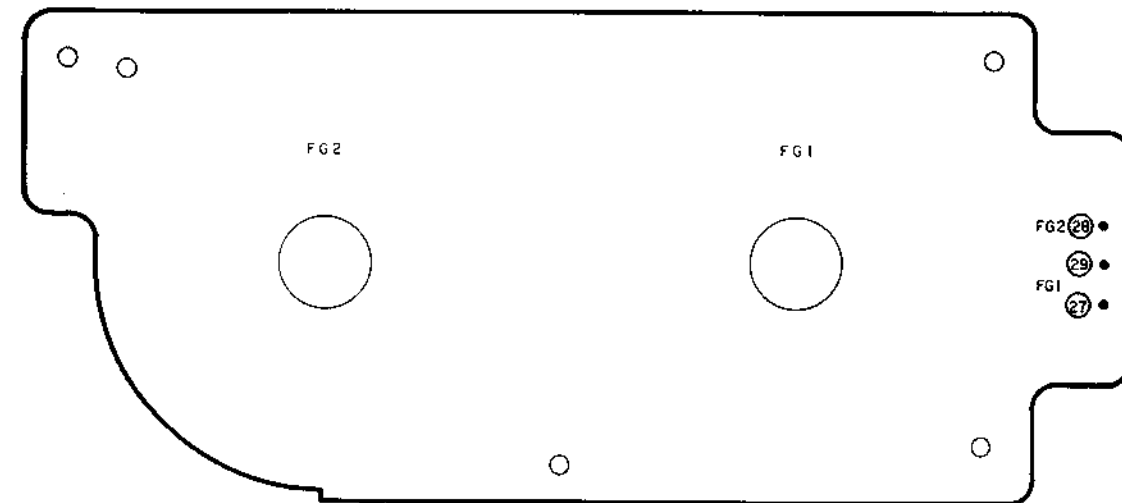

FG PCB M3105C5020

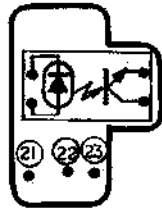

DETECTOR(L) PCB
CMR02D5040

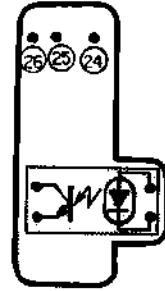

DETECTOR(R) PCB
CMR02D5030

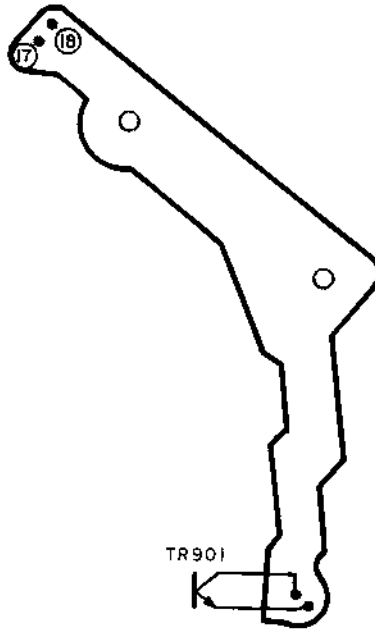

LED PCB
CMR02D5020

10) OTHER P.C BOARDS

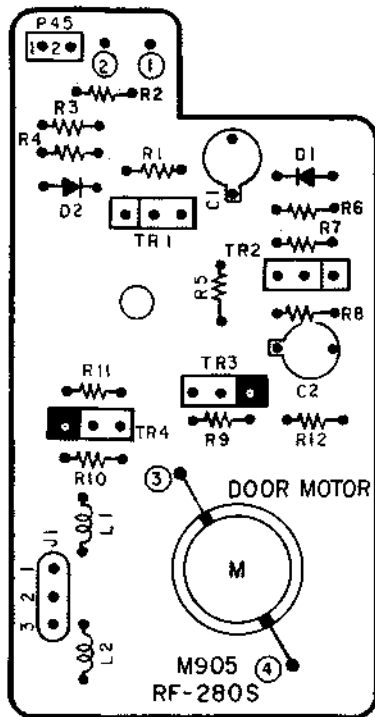

(DOOR) MOTOR PCB
T2049B503B

TR1,2--2SD1012V(G,H)
TR3,4--2SA984K(E,F)

= PNP TRANSISTOR
 = NPN TRANSISTOR

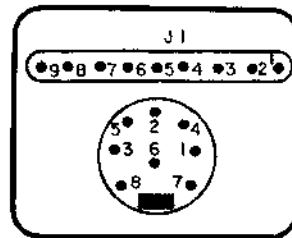
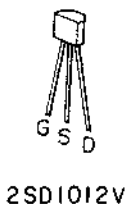
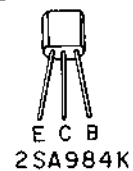

REMOTE CONTROL PCB
T2049B502C

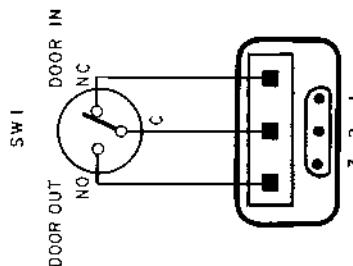

(DOOR) SWITCH PCB
T2049B503C

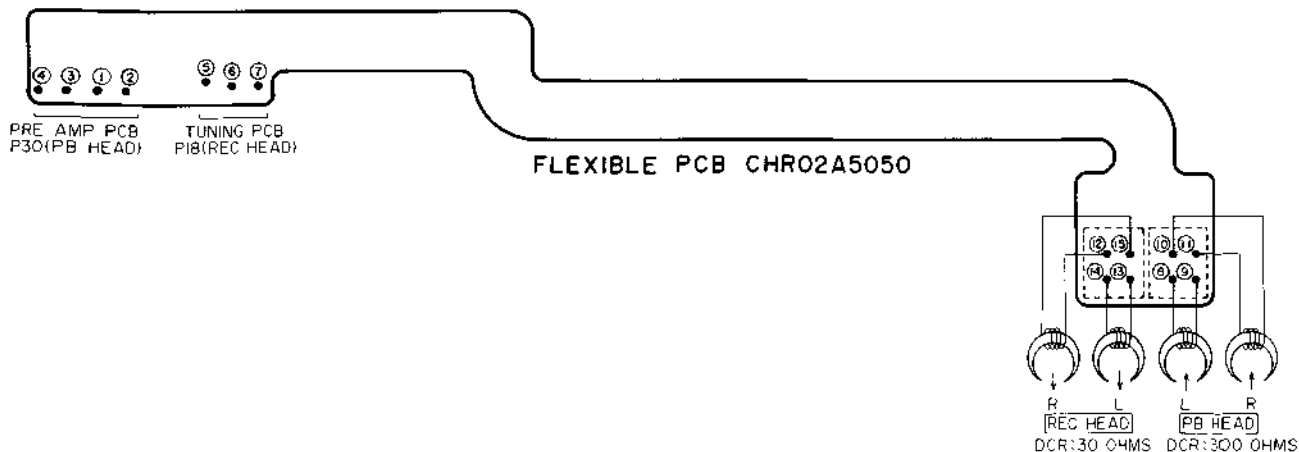
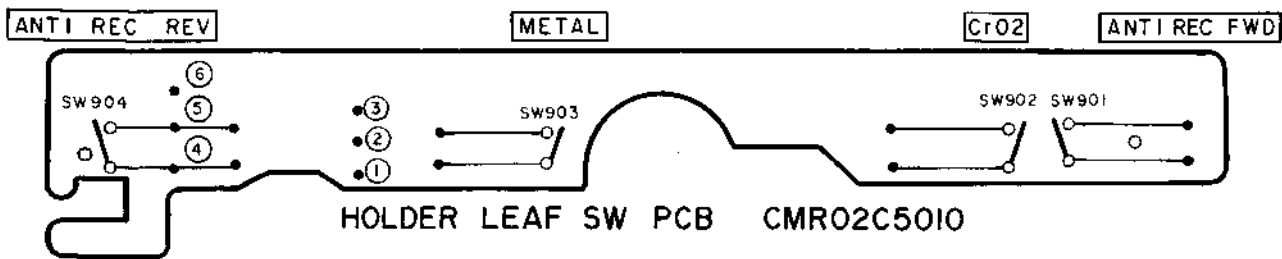

SECTION 3

PARTS LIST

TABLE OF CONTENTS

RECOMMENDED SPARE PARTS	53
1. MECHA CMR02 BLOCK	54
2. MOTOR BLM-500 BLOCK	56
3. TUNING P.C BOARD BLOCK	58
4. PRE AMP P.C BOARD BLOCK	59
5. SYS. CON. P.C BOARD BLOCK	60
6. REC P.C BOARD BLOCK	60
7. METER P.C BOARD BLOCK	60
8. POWER SUPPLY P.C BOARD BLOCK	61
9. POWER SUPPLY (2) P.C BOARD BLOCK	61
10. MOTOR P.C BOARD BLOCK	61
11. SLIDE CASE BLOCK	62
12. ASSEMBLY BLOCK	63
13. FINAL ASSEMBLY BLOCK	64
INDEX	65

Resistors and Capacitors which are not listed in this parts list, please refer to COMMON LIST FOR SERVICE PARTS.

ATTENTION

1. When placing an order for parts, be sure to list the parts no., model no., and description. There are instances in which if any of this information is omitted, parts cannot be shipped or the wrong parts will be delivered.
2. Please be careful not to make a mistake in the parts no. If the parts no. is in error, a part different from the one ordered may be delivered.
3. Because parts number and parts unit supply in the Preliminary Parts List may be partially changed, please use this parts list for all future reference.

HOW TO USE THIS PARTS LIST

1. This Parts List shows the parts that are considered necessary for repairs. Other parts, such as resistors and capacitors, are shown in the "Common List for Service Parts". Select and order such parts from the "Common List for Service Parts".
2. The Recommended Spare Parts shows those parts in the Parts List which are considered particularly important for service.
3. Parts not shown in the Parts List and "Common List for Service Parts" will not be supplied in principle.
4. How to read list
 - a) Mechanism Block
 - b) P.C Board Block

2. HEAD BASE BLOCK

REF. NO.	PARTS NO.	DESCRIPTION
2-1x	BH-T2023A320A	HEAD BASE BLOCK GX-F66R
2-2	HP-H2206A010A	HEAD R/P PR4-8FU C
2-3	ZS-477876	PAN20x03STL CMT
2-4	ZS-536488	BID20x08STL CMT
2-5	ZG-402895	CS ANGLE ADJUST SPRING

SP (Service Parts) Classification

A small "x" indicates the inability to show that particular part in the Photo or Illustration.

This number corresponds with the individual parts index number in that figure

This number corresponds with the Figure Number

6. SYS. CON. P.C BOARD BLOCK

REF. NO.	PARTS NO.	DESCRIPTION
6-1	BA-T2034A070A	PC SYS CON BLK GX-F44R
6-IC1	EI-324536	IC HD14049BP
6-IC2	EI-336801	IC MB8841-564M
6-IC3	EI-331661	IC SN7405N
6-IC4	EI-336725	IC M54527P
6-TR1to4	ET-200985	TR 2SC2603 F,G
6-TR5to28	ET-554657	TR 2SA733A P,Q
6-D1	ED-318292	D SILICON H 1S2473T-77 T26
6-D2to4	ED-308952	D GERMA V 1K34A-LR F07
6-D5to10	ED-318292	D SILICON H 1S2473T-77 T26
6-X1	EI-318384	OSC X'TAL NC-18C 3.579545MHZ

SP (Service Parts) Classification

This reference numbers corresponds with symbol numbers of Schematic Diagrams.

5. Both the kind of part and installation position can be determined by the Parts Number. To determine where a parts number is listed, utilize Parts Index at end of Parts List. It is necessary first of all to find the Parts Number. This can be accomplished by using the Reference Number listed at right of parts number in the Parts Index.

WARNING

⚠ INDICATES SAFETY CRITICAL COMPONENTS. FOR CONTINUED SAFETY, REPLACE SAFETY CRITICAL COMPONENTS ONLY WITH MANUFACTURER'S RECOMMENDED PARTS.

AVERTISSEMENT

⚠ IL INDIQUE LES COMPOSANTS CRITIQUES DE SURETE. POUR MAINTENIR LE DEGRE DE SECURITE DE L'APPAREIL NE REMPLACER LES COMPOSANTS DONT LE FONCTIONNEMENT EST CRITIQUE POUR LA SECURITE QUE PAR DES PIECES RECOMMANDEES PAR LE FABRICANT.

RECOMMENDED SPARE PARTS

Because, if the parts listed below are on hand, almost any repair can be accomplished, we suggest that you stock these Recommended Spare Parts Items.

NO.	PARTS NO.	DESCRIPTION
1	BH-T2049A070A	HEAD BLK GX-R99
2	BM-M3105A010A	Δ MOTOR BLM-500
3	BM-B604527	Δ MOTOR OPERATION PART
4	BM-345196	Δ MOTOR RF-280S
5	BM-B604526	Δ REEL MOTOR PART
6	BR-T2049A040A	REEL TABLE BLK GX-R99
7	BT-348084	Δ TRANS POWER T2049C (A,C)
8	BT-348086	Δ TRANS POWER T2049BS (B,S)
9	BT-348085	Δ TRANS POWER T2049EV (E,V)
10	BT-348083	Δ TRANS POWER T2049J (J)
11	BT-348082	Δ TRANS POWER T2049U (U)
12	BZ-T2049A020A	MECHA CMR02 BLK GX-R99
13	ED-308952	D GERMA V 1K34A-LR F07
14	ED-348137	D LED SG206D (4) GRN
15	ED-337010	D LED SLF201C GRN
16	ED-348135	D LED SR506D (4) RED
17	ED-348121	D LED TLG143 GRN
18	ED-348122	D LED TLY143 YLW
19	ED-330319	D SILICON DBA10B 100/1.0A
20	ED-344280	D SILICON H GMA-01-FY2 F05
21	ED-624903	D SILICON H 1S2473
22	ED-330987	D SILICON RB152 200/1.5A
23	ED-200468	D SILICON V DS448-VB6
24	ED-347767	D SILICON V MC911 DOUBLE
25	ED-347768	D SILICON V MC921 DOUBLE
26	ED-560913	D SILICON V 1S2473VE
27	ED-330622	D SILICON 1SR35-100VL 100/1.0A
28	ED-346493	D ZENER H HZ15FA F10 2
29	ED-346503	D ZENER H HZ20FA F10 2
30	ED-346505	D ZENER H HZ22FA F10 1
31	ED-346462	D ZENER H HZ27FA F10 C2
32	ED-346440	D ZENER H HZ5FA F10 B1
33	ED-346445	D ZENER H HZ5FA F10 C2
34	ED-346446	D ZENER H HZ5FA F10 C3
35	ED-346454	D ZENER H HZ6FA F10 C3
36	ED-346473	D ZENER H HZ9FA F10 C3
37	ED-348001	D ZENER V HZ2B-1S7
38	ED-338453	D ZENER V HZ4B-2S7
39	ED-338082	D ZENER V HZ5C-1S7
40	ED-336998	D ZENER V HZ6B-2S7
41	ED-337867	D ZENER V HZ6C-2S7
42	ED-337867	D ZENER V HZ6C-2S7
43	EF-601942	Δ FUSE SEMKO T 250V 0.63A (E,V,B,S)
44	EF-623103	Δ FUSE SEMKO T 250V 1.00A (E,V,B,S)
45	EF-601964	Δ FUSE SEMKO T 250V 1.60A (E,V,B,S)
46	EF-306124	Δ FUSE TSC A 250V 0.63A (J)
47	EF-309387	Δ FUSE TSC A 250V 1.00A (U,J)
48	EF-311839	Δ FUSE TSC A 250V 1.60A (U,J)
49	EF-305703	Δ FUSE TSC 125V 0.63A (C,A)
50	EF-310229	Δ FUSE TSC 125V 1.00A (C,A)
51	EF-308847	Δ FUSE TSC 125V 1.60A (C,A)
52	EH-337380	FILTER CE KMFC-1001S 3.58MHZ
53	EH-336775	FILTER DB D07001K 19KHZ
54	EH-336776	FILTER DB D07003K 100KHZ
55	EH-347991	OSC CE CSA6.00MS 6.00000MHZ
56	EI-336987	HALL ELEMENT DHD-H150
57	EI-330352	IC BA6109
58	EI-348105	IC HA12010
59	EI-349196	IC HA12058
60	EI-338416	IC HA17408P
61	EI-328593	IC HD14053BP
62	EI-349554	IC HD44860L14
63	EI-336761	IC LA6458S
64	EI-337013	IC LB1290
65	EI-345765	IC LB1292
66	EI-338171	IC LC4069UB
67	EI-348111	IC LC4071B

NO.	PARTS NO.	DESCRIPTION
68	EI-337008	IC LC7800
69	EI-348109	IC M5L8049-137P-6
70	EI-348110	IC M5L8243P
71	EI-348104	IC M50780SP
72	EI-348701	IC M51143L
73	EI-337228	IC M5218L0
74	EI-348123	IC M5230AL
75	EI-307644	IC NJM4556D
76	EI-201940	IC NJM4558S
77	EI-337126	IC TA7332P
78	EI-337529	IC TA78L005AP
79	EI-304657	IC TC4011BP
80	EI-305456	IC TC4049BP
81	EI-310036	IC TC4066BP
82	EI-337360	IC μPC1043C
83	EI-337360	IC μPC4082C
84	EI-348108	IC μPD1511C-134
85	EI-337237	IC μPD4050BC
86	EI-338238	IC μPD4051BC
87	EI-347923	IC μPD4071BP
88	EI-348106	IC 51133P
89	EI-337017	OSC CE CSB800A 0.800000MHZ
90	EM-348120	IND FL BG-152Z DOUBLE
91	EO-315758	COIL TUN 1 100S-431 100.00KHZ
92	EO-336738	COIL TUN 1 102AK-004 19.80KHZ
93	EO-337055	COIL VARI 1 FE002S 10MH
94	EO-331280	COIL VARI 1 46-1072-11 22MH
95	EQ-344440	RELAY SIGNAL G2V-282P 2TR 24V
96	ER-318248	Δ R FUSE ERD2FC S10 1/4W 47R0G
97	ER-348272	Δ R FUSE ERD2FC S10 1/4W 12R0G
98	ER-331188	Δ R FUSE ERD2FC S10 1/4W 8R2J
99	ER-350808	Δ R FUSE ERQ14AJ S10 1/4W 181J
100	ES-336990	SW LEAF BSW-169 01-1 NO
101	ES-348124	SW LEAF MSW-1127A 01-1NO
102	ES-344253	SW LEAF MSW-1418J 01-1 NO
103	ES-344257	SW LEAF MSW-1418L 01-1 NO
104	ES-337427	SW MICRO SS-01-E
105	ES-691457	SW MICRO VV-SR
106	ES-348133	SW PUSH ESB-62746 3 THROW
107	ES-346260	SW PUSH SPH121A 2-02-02N
108	ES-348998	SW PUSH SDL1P 01-1
109	ES-305733	SW SELECTOR HXW0131-260 01-4 (U)
110	ES-336780	SW TACT KHH10902
111	ET-310341	PHOTO SENSOR PT350 T
112	ET-345091	PHOTO SENSOR SPI-201-40 B,C
113	ET-321016	TR FET 2SK117 GR,BL
114	ET-341400	TR FET 2SK170 BL,GR
115	ET-337234	TR FET 2SK270 GR,BL
116	ET-348302	TR FET 2SK381 C,D
117	ET-200558	TR 2SA1115 E,F
118	ET-350806	TR 2SA1115 F,G
119	ET-348950	TR 2SA1345
120	ET-349725	TR 2SA1391 S,T
121	ET-349718	TR 2SA1392 S,T
122	ET-554657	TR 2SA733A P,Q
123	ET-337112	TR 2SA798 F,G
124	ET-337012	TR 2SA984K D,E
125	ET-324134	TR 2SA984K E,F
126	ET-337968	TR 2SA999 E,F
127	ET-322598	TR 2SB632K E,F
128	ET-318237	TR 2SB764 E,F
129	ET-337188	TR 2SB774 P,Q
130	ET-347969	TR 2SB808-V F,G,H
131	ET-336997	TR 2SB808-V G,H
132	ET-308976	TR 2SC1815 BL,GR
133	ET-337011	TR 2SC2274K D,E
134	ET-310833	TR 2SC2274K E
135	ET-330270	TR 2SC2320 F,G
136	ET-200505	TR 2SC2603 E,F
137	ET-200985	TR 2SC2603 F,G
138	ET-338410	TR 2SC2878 A,B
139	ET-349080	TR 2SC3382 S,T

NO.	PARTS NO.	DESCRIPTION
140	ET-349081	TR 2SC3383 S,T
141	ET-350795	TR 2SC3399
142	ET-319638	TR 2SD1012-V F,G,H
143	ET-347961	TR 2SD1012-V G
144	ET-328868	TR 2SD1012-V G,H
145	ET-350816	TR 2SD549 E,F
146	ET-350948	TR 2SD612K F
147	ET-307349	TR 2SD794 P,Q
148	EV-337052	VR ROTARY 16L10XOR B103
149	EV-337841	VR SLIDE 30P2SV0A B103
150	HE-H2302A010A	HEAD E E4-11
151	HE-H2303A010A	HEAD E E4-11S
152	HP-H2404A010A	HEAD COMBO PR4-10
153	MB-345201	BELT
154	MB-345193	BELT CAPSTAN
155	MB-345179	BELT GEAR
156	MB-344989	BELT OPERATION (B)
157	MI-T2049A030A	IDLER BLK GX-R99
158	MP-344980	ROLLER PINCH (B)
159	MZ-344004	GEAR HEAD
160	MZ-336005	GEAR POTENTION
161	MZ-B345155	GEAR REVERSE PART

I. MECHA CMR02 BLOCK

REF. NO.	PARTS NO.	DESCRIPTION
1-1	BZ-T2049A020A	MECHA CMR02 BLK GX-R99
HEAD BLOCK		
1-2	BH-T2049A070A	HEAD BLK GX-R99
1-3	MA-B344940	CHASSIS HEAD PART
1-4	HZ-B344009	HOUSING ROTARY PART
1-5	HP-H2404A010A	HEAD COMBO PR4-10
1-6	HZ-B344006	HOLDER ROTARY PART
1-7	ZS-245147	CTS20x06STL BNI
1-8	HZ-344011	GUIDE ROTARY HEAD
1-9	ZS-344001	SCREW AZIMUTH
1-10	ZW-273734	N20BRS NI3 1
1-11	MZ-344004	GEAR HEAD
1-12	ZG-344012	SP PUSH GUIDE TAPE
1-13	ZW-391397	RING E120SUP CMT
1-14	HE-H2302A010A	HEAD E E4-11
1-15	HE-H2303A010A	HEAD E E4-11S
1-16	ZW-618884	N20STL CMT 1
1-17	TC-344942	SLIDE CHANGE
1-18	ZS-481645	BID26x03STL CMT
1-19	ZG-344988	SP TORSION RACK
1-20	ZW-350766B	SPACER ADJUST (B)
1-21	ZW-344639G	SPACER ADJUST (G) 0.40MM
1-22	HZ-344015	COVER HOUSING
1-23	ZS-345773	BID17x06STL BNI
1-24	ZS-524812	CTS20x04STL CMT

IDLER BLOCK

1-25	MI-T2049A030A	IDLER BLK GX-R99
------	---------------	------------------

REEL TABLE BLOCK

1-26	BR-T2049A040A	REEL TABLE BLK GX-R99
------	---------------	-----------------------

ARM PINCH ROLLER (R) BLOCK

1-27	BL-T2049A050A	ARM PINCH ROLLER (R) BLK GX-R99
1-28	MP-344980	ROLLER PINCH (B)
1-29	ZG-349030	SP
1-30	ZW-350890	PW12x032x025PSL
1-31	ZG-349178	SP

ARM PINCH ROLLER (L) BLOCK

1-32	BL-T2049A060A	ARM PINCH ROLLER (L) BLK GX-R99
------	---------------	---------------------------------

MECHA CMR02 BLOCK

1-33	SZ-336166	COLLAR LID
1-34	ML-344949	LEVER BRAKE (A)
1-35	TC-336146	BRAKE RUBBER
1-36	ML-344950	LEVER BRAKE (B)
1-37	ZG-312946	SP T1-3.2/0.29-16.0 T1-062
1-38	ML-B344951	LEVER BT (L) PART
1-39	ZG-344987	SP PULL BT
1-40	ML-B344952	LEVER BT (R) PART
1-41	ZG-349177	SP PULL PINCH ROLLER (L)
1-42	ZG-344985	SP PULL PINCH ROLLER (R)
1-43	ZW-356657	RING E 150SUP CMT
1-44	ML-345073	LEVER BT CHANGE (R)
1-45	ZW-329422	RING CS0300
1-46	ML-345074	LEVER BT CHANGE (L)
1-47	ML-344961	LEVER HEAD BASE (A)
1-48	ML-B344962	LEVER HEAD BASE (B) PART
1-49	ZG-344964	SP TORSION (A)
1-50	ZW-329422	RING CS0300
1-51	ZG-344960	SP TORSION IDLER
1-52	ZG-336141	SP PUSH BT
1-53	TC-336142	HOLDER BT SP
1-54	ZW-330073	PW21x040x020
1-55	MT-305793	REEL CAP
1-56	TC-336161	SLIDE EJECT
1-57	ZW-329422	RING CS0300
1-58	TC-344982	PROP REFERENCE
1-59	ML-344953	LEVER DETECTION (A)
1-60	ML-344954	LEVER DETECTION (B)

REF. NO.	PARTS NO.	DESCRIPTION
1-61	ES-344257	SW LEAF MSW-1418L 01-1 NO (SW901)
1-62	ES-344253	SW LEAF MSW-1418J 01-1 NO (SW902)
1-63	ES-344257	SW LEAF MSW-1418L 01-1 NO (SW904)
1-64	ES-344253	SW LEAF MSW-1418J 01-1 NO (SW903)
1-65	ML-344955	LEVER DETECTION (C)
1-66	ZG-312998	SP T1-4.0/0.4-18.0 T1-112
1-67	ZS-460440	PAN20x04STL CMT
1-68	ET-345091	PHOTO SENSOR SPI-201-40 B,C
1-69	ES-336990	SW LEAF BSW-169 01-1 NO (SW905)
1-70	MV-666887	BALL D2.5
1-71	ET-310341	PHOTO SENSOR PT350 T (TR901)
1-72	HZ-349298	PLATE HEAD HOLDER
1-73	ZS-336613	PT PAN26x06STL CMT
1-74	ZG-349033	SP ARM PINCH ROLLER (R)
1-75	ZG-349034	SP ARM PINCH ROLLER (L)
1-76	ZW-350839	NYLON NUT M3
1-77	ZW-259650	PW30x050x020PBR
1-78	ZW-270088	RING E 190SUP CMT
1-79	SP-336163	LID CASE
1-80	ZG-336615	SP PLATE CASSETTE HOLDER (B)
1-81	BD-B348464	LID DECORATION PART
1-82	ED-337010	D LED SLF201C GRN (D901)
1-83	BZ-T2030A110A	OIL CLUTCH BLK GX-F51
1-84	ZW-270088	RING E 190SUP CMT
1-85	ES-337427	SW MICRO SS-01-E (SW907)
1-86	ZS-310337	PAN20x08STL CMT

MOTOR BLM-500 BLOCK

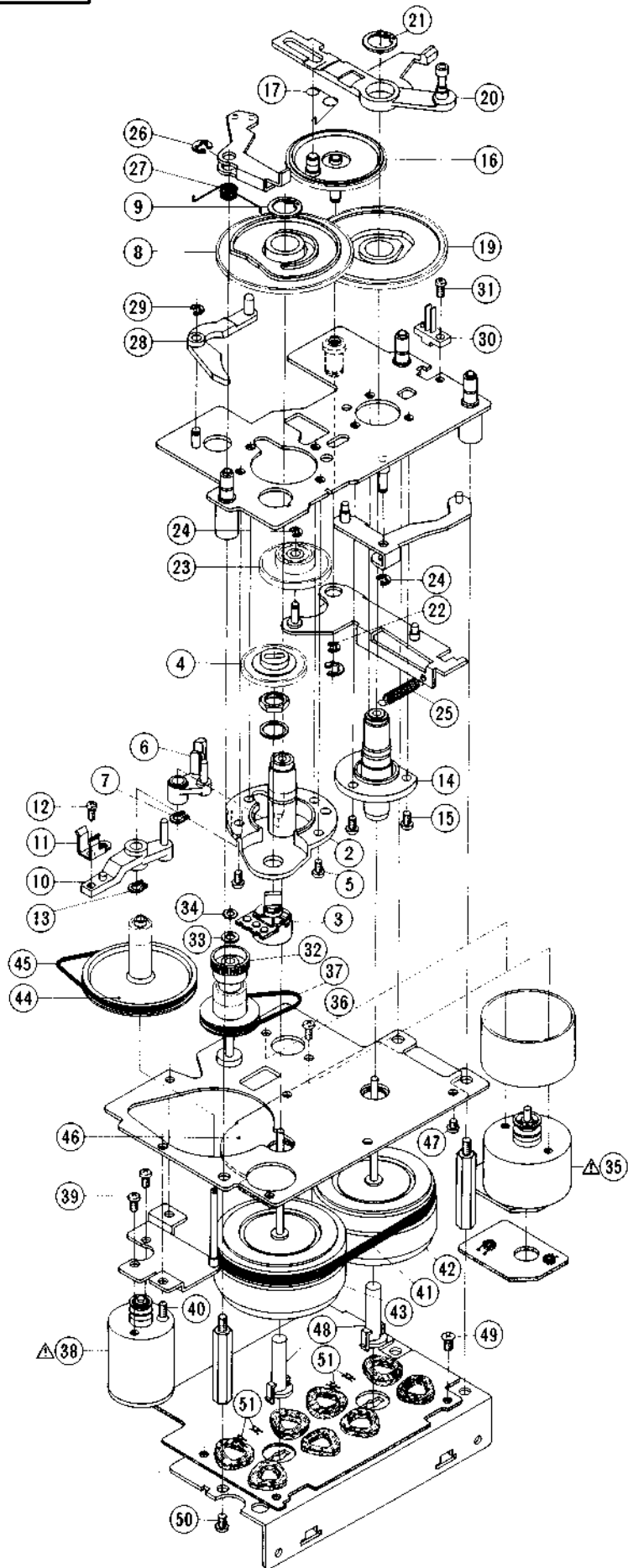

2. MOTOR BLM-500 BLOCK

REF. NO.	PARTS NO.	DESCRIPTION
2-1	BM-M3105A010A	△ MOTOR BLM-500
2-2	TC-B345188	HOLDER CAPSTAN (A) PART
2-3	EV-337052	VR ROTARY 16L10×OR B103
2-4	MZ-336005	GEAR POTENTION
2-5	ZS-432843	PAN26×04STL CMT
2-6	BL-B336007X1	LEVER BRAKE CAM (1) PART
2-7	ZW-336603	RING GRIP 285SUP ACP
2-8	MZ-345169	CAM WHEEL
2-9	ZW-336604	RING S930SUP ACP
2-10	BL-B336009	LEVER EJECT CAM PART
2-11	ZG-336011	SP PLATE CAM LEVER
2-12	ZS-377876	PAN20×03STL CMT
2-13	ZW-336603	RING GRIP 285SUP ACP
2-14	TC-B345187	HOLDER CAPSTAN (B) PART
2-15	ZS-432843	PAN26×04STL CMT
2-16	MZ-B345155	GEAR REVERSE PART
2-17	ZG-349029	SP TORSION GEAR REVERSE
2-18	ZW-270088	RING E 190SUP CMT
2-19	MZ-345170	CAM WHEEL (R)
2-20	BL-B345159	LEVER REVERSE PART
2-21	ZW-336604	RING S930SUP ACP
2-22	ZW-270134	RING E500SUP CMT
2-23	MZ-345165	GEAR IDLER
2-24	ZW-270088	RING E 190SUP CMT
2-25	ZG-313002	SP T1-4.0/0.4-25.0 T1-115
2-26	ZW-270123	RING E400SUP CMT
2-27	ZG-344984	SP TORSION (R)
2-28	ML-345173	LEVER RELEASE
2-29	ZW-270088	RING E 190SUP CMT
2-30	ES-336990	SW LEAF BSW-169 01-1 NO
2-31	ZS-460440	PAN20×04STL CMT
2-32	MR-B345184	PULLEY MAIN PART
2-33	ZW-259661	PW30×050×025PSL
2-34	ZW-282407	PUSH WASHER (B)
2-35	BM-B604526	△ REEL MOTOR PART
2-36	ZS-592378	PAN26×03STL CMT
2-37	MB-345179	BELT GEAR
2-38	BM-B604527	△ MOTOR OPERATION PART
2-39	ZS-592378	PAN26×03STL CMT
2-40	ZS-477887	CTS26×05STL CMT
2-41	MB-345193	BELT CAPSTAN
2-42	BF-B345189	FLYWHEEL (A) PART
2-43	BF-B345190	FLYWHEEL (B) PART
2-44	MR-336019	PULLEY OPERATE
2-45	MB-344989	BELT OPERATION (B)
2-46	EA-345195	PC FG
2-47	ZS-321194	ST PAN26×05STL CMT
2-48	TC-345181	HOLDER THRUST
2-49	ZS-477887	CTS26×05STL CMT
2-50	ZS-422076	PAN30×05STL CMT
2-51	EI-336987	HALL ELEMENT DHD-H150 (IC3,4)

3. TUNING P.C BOARD BLOCK

REF. NO.	PARTS NO.	DESCRIPTION	REF. NO.	PARTS NO.	DESCRIPTION
3-1	BA-T2049A150A	PC TUNING BLK GX-R99	3-D18	ED-347768	D SILICON V MC921 DOUBLE
3-IC1	EI-304657	IC TC4011BP	3-D19	ED-337867	D ZENER V HZ6C-2S7
3-IC2	EI-337228	IC M5218L0	3-D20	ED-336998	D ZENER V HZ6B-2S7
3-IC3,4	EI-345765	IC LB1292	3-D21to24	ED-338453	D ZENER V HZ4B-2S7
3-IC5	EI-305456	IC TC4049BP	3-D25to51	ED-344280	D SILICON H GMA-01-FY2 F05
3-IC6	EI-352230	IC HD44860L23	3-D52to55	ED-347768	D SILICON V MC921 DOUBLE
3-IC7	EI-348104	IC M50780SP	3-D56	ED-344280	D SILICON H GMA-01-FY2 F05
3-IC8	EI-345765	IC LB1292	3-D57,58	ED-347768	D SILICON V MC921 DOUBLE
3-IC9	EI-338238	IC μPD4051BC	3-D59	ED-344280	D SILICON H GMA-01-FY2 F05
3-IC10to14	EI-336761	IC LA6458S	3-D60to63	ED-347768	D SILICON V MC921 DOUBLE
3-IC15	EI-338238	IC μPD4051BC	3-D72	ED-347767	D SILICON V MC911 DOUBLE
3-IC16	EI-348105	IC HA12010	3-D76,78	ED-347768	D SILICON V MC921 DOUBLE
3-IC17	EI-337013	IC LB1290	3-D80to87	ED-344280	D SILICON H GMA-01-FY2 F05
3-IC18	EI-338238	IC μPD4051BC	3-D89,90	ED-344280	D SILICON H GMA-01-FY2 F05
3-IC19	EI-345765	IC LB1292	3-D91	ED-346445	D ZENER H HZ5FA F10 C2
3-IC20	EI-338416	IC HA17408P	3-D92,93	ED-344280	D SILICON H GMA-01-FY2 F05
3-IC21	EI-310036	IC TC4066BP	3-D94	ED-337867	D ZENER V HZ6C-2S7
3-IC22	EI-336761	IC LA6458S	3-D95	ED-624903	D SILICON H 1S2473
3-IC23	EI-337360	IC μPC4082C	3-VR1	EV-315416	R S-FIX H D8 3P 103
3-IC24,25	EI-336761	IC LA6458S	3-VR2,3	EV-330531	R S-FIX H TM8KV2-1S 3P 0.50W 503
3-IC26	EI-337360	IC μPC4082C	3-VR4	EV-315416	R S-FIX H D8 3P 103
3-IC27to35	EI-336761	IC LA6458S	3-VR5	EV-315413	R S-FIX H D8 3P 503
3-IC36	EI-348106	IC 51133P	3-VR6	EV-315414	R S-FIX H D8 3P 203
3-IC37	EI-337237	IC μPD4050BC	3-VR7	EV-315416	R S-FIX H D8 3P 103
3-IC38	EI-337529	IC TA78L005AP	3-VR8,9	EV-315413	R S-FIX H D8 3P 503
3-IC39	EI-347923	IC μPD4071BP	3-VR10	EV-321637	R S-FIX H D8 3P 104
3-TR1,2	ET-200505	TR 2SC2603 E,F	3-VR11	EV-315414	R S-FIX H D8 3P 203
3-TR3to11	ET-200558	TR 2SA1115 E,F	3-VR12	EV-315412	R S-FIX H D8 3P 502
3-TR12,13	ET-328868	TR 2SD1012-V G,H	3-VR13	EV-315416	R S-FIX H D8 3P 103
3-TR14to16	ET-200505	TR 2SC2603 E,F	3-VR14	EV-351222	R S-FIX H D8 3P 304
3-TR21	ET-338410	TR 2SC2878 A,B	3-VR17to20	EV-315414	R S-FIX H D8 3P 203
3-TR22	ET-328868	TR 2SD1012-V G,H	3-L1	EO-337055	COIL VARI 1 FE002S 10MH
3-TR23	ET-349081	TR 2SC3383 S,T	3-L2,3	EO-343768	COIL FIX 1 FL09H 391K
3-TR24	ET-341400	TR FET 2SK170 BL,GR	3-T1	EO-348100	COIL OSC 1 25-5059-22
3-TR25	ET-200558	TR 2SA1115 E,F	3-T2	EO-348101	COIL OSC 2 25-5060-02
3-TR26to34	ET-349081	TR 2SC3383 S,T	3-FL1	EO-315758	COIL TUN 1 100S-431 100.00KHZ
3-TR35to42	ET-200505	TR 2SC2603 E,F	3-FL2	EI-337017	OSC CE CSB800A 0.800000MHZ
3-TR43	ET-328868	TR 2SD1012-V G,H	3-FL3	EC-348300	C COMP CSC101K
3-TR44	ET-318237	TR 2SB764 E,F	3-RL1	EQ-344440	RELAY SIGNAL G2V-282P 2TR 24V
3-TR45	ET-308976	TR 2SC1815 BL,GR	3-VC1	EC-348292	C S-FIX H ECR-BA160N11 12-160
3-TR46	ET-328868	TR 2SD1012-V G,H	3-R83	ER-350688	R MF H 1/4W 222J
3-TR47,48	ET-310833	TR 2SC2274K E	3-R84	ER-302157	R MF H 1/4W 512J
3-TR49,50	ET-200505	TR 2SC2603 E,F	3-FR1,2	ER-331188	Δ R FUSE ERD2FC S10 1/4W 8R2J
3-TR51	ET-322598	TR 2SB632K E,F	3-FR3,4	ER-348272	Δ R FUSE ERD2FC S10 1/4W 12R0G
3-TR52	ET-308976	TR 2SC1815 BL,GR	3-C7to9	EC-300193	C EC V F05 NP SM 100M 16DC
3-TR53,54	ET-310833	TR 2SC2274K E	3-C12	EC-350679	C COMP V AWS 183J 50DC
3-TR55	ET-200558	TR 2SA1115 E,F	3-C13	EC-300193	C EC V F05 NP SM 100M 16DC
3-TR56to60	ET-328868	TR 2SD1012-V G,H	3-C16	EC-351996	C COMP V AWS 822J 50DC
3-TR61,62	ET-200505	TR 2SC2603 E,F	3-C18	EC-350680	C COMP V AWS 123J 50DC
3-TR63	ET-200558	TR 2SA1115 E,F	3-C20	EC-350679	C COMP V AWS 183J 50DC
3-TR64	ET-200505	TR 2SC2603 E,F	3-C21,22	EC-352007	C COMP V AWS 162J 50DC
3-TR65	ET-348302	TR FET 2SK381 C,D	3-C23	EC-351998	C PP V F05 PP 821J 50DC
3-TR66,67	ET-328868	TR 2SD1012-V G,H	3-C24	EC-344486	C PP V F05 PP 391J 50DC
3-TR68	ET-200558	TR 2SA1115 E,F	3-C25	EC-352006	C COMP V AWS 362J 50DC
3-TR69	ET-328868	TR 2SD1012-V G,H	3-C35	EC-307684	C EC V F05 NP SM R47M 50DC
3-TR70	ET-200505	TR 2SC2603 E,F	3-C52	EC-348293	C PP V F10 ECQ-F 122J 630DC
3-TR71,72	ET-200558	TR 2SA1115 E,F	3-C53	EC-328774	C STY V SNP CQFS 331J 250DC
3-TR73,74	ET-328868	TR 2SD1012-V G,H	3-C54	EC-201021	C STY V F05 CQF09 151J 250DC
3-TR75,76	ET-349081	TR 2SC3383 S,T	3-C55	EC-348273	C STY V S05 CQFS 121J 250DC
3-TR77	ET-200505	TR 2SC2603 E,F	3-C56,57	EC-338435	C PP V F05 FPS 3302G 100DC
3-TR78	ET-328868	TR 2SD1012-V G,H	3-C70to73	EC-200948	C EC V F05 NP SM 1R0M 50DC
3-TR79,80	ET-200505	TR 2SC2603 E,F	3-C82	EC-300193	C EC V F05 NP SM 100M 16DC
3-TR81	ET-328868	TR 2SD1012-V G,H	3-C95	EC-200948	C EC V F05 NP SM 1R0M 50DC
3-TR82,83	ET-200505	TR 2SC2603 E,F	3-C96	EC-343855	C EC V F05 NP SM R22M 50.0DC
3-TR84,85	ET-349081	TR 2SC3383 S,T	3-C100	EC-312012	C STY V SNP CQF09 561J 50DC
3-TR86,87	ET-200505	TR 2SC2603 E,F	3-C103	EC-352006	C COMP V AWS 362J 50DC
3-TR88	ET-200558	TR 2SA1115 E,F	3-C104	EC-351999	C PP V F05 PP 911J 50DC
3-TR89to92	ET-200505	TR 2SC2603 E,F	3-C110	EC-352008	C COMP V AWS 912J 50DC
3-TR93	ET-200558	TR 2SA1115 E,F	3-C117,118	EC-332052	C EC V F05 NP SM 4R7M 35DC
3-TR94	ET-328578	TR 2SC2320 E,F	3-BT1	AV-332302	BATTERY VP-88
3-TR95	ET-200558	TR 2SA1115 E,F			
3-TR96	ET-200505	TR 2SC2603 E,F			
3-TR97	ET-349081	TR 2SC3383 S,T			
3-D1to12	ED-344280	D SILICON H GMA-01-FY2 F05			
3-D14to17	ED-344280	D SILICON H GMA-01-FY2 F05			

4. PRE AMP P.C BOARD BLOCK

REF. NO.	PARTS NO.	DESCRIPTION
4-1A	BA-T2048A080B	PC PRE AMP IC BLK GX-R99 (IC58)
RE AMP P.C BOARD		
4-IC1A	EI-349196	IC HA12058
4-IC2A	EI-348701	IC M51143L
4-IC3A	EI-307644	IC NJM4556D
4-IC4A	EI-328593	IC HD14053BP
4-IC5A,6A	EI-336761	IC LA6458S
4-IC7A	EI-337126	IC TA7332P
4-IC8A	EI-336761	IC LA6458S
4-IC9A	EI-337360	IC μ PC4082C
4-IC10A	EI-349196	IC HA12058
4-TR1A	ET-330270	TR 2SC2320 F,G
4-TR2A	ET-321016	TR FET 2SK117 GR,BL
4-TR3A	ET-307349	TR 2SD794 P,Q
4-TR4A	ET-330270	TR 2SC2320 F,G
4-TR5A	ET-350806	TR 2SA1115 F,G
4-TR6A	ET-330270	TR 2SC2320 F,G
4-TR7A	ET-349081	TR 2SC3383 S,T
4-TR8A	ET-349718	TR 2SA1392 S,T
4-TR9Ato11A	ET-341400	TR FET 2SK170 BL,GR
4-TR12A	ET-350795	TR 2SC3399
4-TR13A	ET-348950	TR 2SA1345
4-TR14A	ET-349081	TR 2SC3383 S,T
4-TR15A	ET-348950	TR 2SA1345
4-TR16A	ET-330270	TR 2SC2320 F,G
4-TR17A	ET-348950	TR 2SA1345
4-TR18A	ET-350795	TR 2SC3399
4-TR19Ato22A	ET-330270	TR 2SC2320 F,G
4-TR23A	ET-350795	TR 2SC3399
4-TR24A	ET-348950	TR 2SA1345
4-TR25A	ET-350795	TR 2SC3399
4-TR26A	ET-348950	TR 2SA1345
4-TR27A	ET-330270	TR 2SC2320 F,G
4-TR28A	ET-337234	TR FET 2SK270 GR,BL
4-TR29A	ET-349081	TR 2SC3383 S,T
4-TR30A	ET-337112	TR 2SA798 F,G
4-TR31A,32A	ET-349080	TR 2SC3382 S,T
4-TR33A	ET-349725	TR 2SA1391 S,T
4-TR34A	ET-349080	TR 2SC3382 S,T
4-TR35A	ET-349725	TR 2SA1391 S,T
4-TR36A	ET-330270	TR 2SC2320 F,G
4-TR37A	ET-349081	TR 2SC3383 S,T
4-D1	ED-346493	D ZENER H HZ15FA F10 2
4-D2Ato 4A	ED-344280	D SILICON H GMA-01-FY2 F05
4-D5A	ED-346478	D ZENER H HZ11FA F10 B2
4-D6A	ED-346633	D SILICON W03B F10 100/1.0A
4-D7Ato10A	ED-344280	D SILICON H GMA-01-FY2 F05
4-D11A,12A	ED-308952	D GERMA V 1K34A-LR F07
4-D13A	ED-344280	D SILICON H GMA-01-FY2 F05
4-D14A	ED-200468	D SILICON V DS448-VB6
4-D15A	ED-344280	D SILICON H GMA-01-FY2 F05
4-D16A	ED-200468	D SILICON V DS448-VB6
4-VR2A	EV-337995	R S-FIX H RVF8P01 3P 103
4-VR3A	EV-337993	R S-FIX H RVF8P01 3P 203
4-VR4A	EV-345297	R S-FIX V TM8KH1-1S 3P 0.50W 101
4-VR5A	EV-338588	R S-FIX H RVF8P01 3P 503
4-VR6A	EV-325994	R S-FIX V H1052A 3P 0.15W 103
4-FL1A	EH-336776	FILTER DB D07003K 100KHZ
4-FL2A	EH-336775	FILTER DB D07001K 19KHZ
4-FL3A	EO-336738	COIL TUN 1 102AK-004 19.80KHZ
4-FL4A	EH-336776	FILTER DB D07003K 100KHZ
4-FL5A	EO-336738	COIL TUN 1 102AK-004 19.80KHZ
4-R40A	ER-520863	R CB H RD 1/2W 221J
4-R77A,78A	ER-559192	R CB H RD 1/2W 201J
4-R108A	ER-338183	R MF H 1/4W 104J
4-R111A,112A	ER-347958	R MF H 1/4W 272J
4-R113A,114A	ER-348130	R MF H F10 1/4W 47R0G
4-R116A	ER-347959	R MF H 1/4W 561J
4-R117A	ER-302156	R MF H 1/4W 472J
4-R121A,122A	ER-347957	R MF H 1/4W 133J

REF. NO.	PARTS NO.	DESCRIPTION
4-R124A	ER-347957	R MF H 1/4W 133J
4-FR1A	ER-350808	R FUSE ERQ14AJ S10 1/4W 181J
4-C8A	EC-338506	C COMP V AWS 103J 50DC
4-C9A	EC-350679	C COMP V AWS 183J 50DC
4-C14A	EC-351992	C COMP V AWS 472J 50DC
4-C15A	EC-351993	C COMP V AWS 562J 50DC
4-C20A	EC-351995	C COMP V AWS 823J 50DC
4-C64A	EC-351993	C COMP V AWS 562J 50DC
4-C65A	EC-341409	C COMP V AWS 6801G 50DC
4-C70A	EC-352009	C COMP V AWS 113J 50DC
4-C71A	EC-351994	C COMP V AWS 152J 50DC
4-C84A	EC-318314	C COMP AWS 333J 50DC
4-C85A	EC-338506	C COMP V AWS 103J 50DC
4-C87A	EC-350679	C COMP V AWS 183J 50DC
4-C92A,93A	EC-351992	C COMP V AWS 472J 50DC
4-C94A	EC-351993	C COMP V AWS 562J 50DC
4-C98A	EC-351995	C COMP V AWS 823J 50DC
4-J1A	EJ-351899	PIN J YKC21-5078 P 4P
HEAD PHONE P.C BOARD		
4-J5B	EJ-348160	PHONE J HJ0540-040 6.3
SWITCH P.C BOARD		
4-SW1C	ES-348133	SW PUSH ESB-62746 3 THROW
OUT VOLUME P.C BOARD		
4-VR1D	EV-337841	VR SLIDE 30P2SV0A B103
COIL P.C BOARD		
4-VL1F	EO-331280	COIL VARI 1 46-1072-11 22MH
4-VL1G	EO-331280	COIL VARI 1 46-1072-11 22MH

5. SYS. CON. P.C BOARD BLOCK

REF. NO.	PARTS NO.	DESCRIPTION
5-1	BA-T2049A140A	PC SYSCON BLK GX-R99
SYS. CON. P.C BOARD		
5-IC201A	EI-348108	IC μ PD1511C-134
5-IC202A	EI-352232	IC M5L8049-154P-6
5-IC203A	EI-348110	IC M5L8243P
5-IC204A,205A	EI-337008	IC LC7800
5-IC206Ato205A	EI-337013	IC LB1290
5-IC209A	EI-348111	IC LC4-71B
5-IC210A,211A	EI-337671	IC LA6458S
5-IC212Ato214A	EI-338171	IC LC4069UB
5-TR201Ato206A	ET-319638	TR 2SD1012-V F,G,H
5-TR207A	ET-554657	TR 2SA733A P,Q
5-TR209A	ET-200505	TR 2SC2603 E,F
5-TR210A,211A	ET-328868	TR 2SD1012-V G,H
5-TR212A,213A	ET-347969	TR 2SB808-V F,G,H
5-TR214A,215A	ET-200505	TR 2SC2603 E,F
5-TR216A	ET-200558	TR 2SA1115 E,F
5-TR217A	ET-326997	TR 2SB808-V G,H
5-TR218A	ET-328868	TR 2SD1012-V G,H
5-D201Ato204A	ED-344280	D SILICON H GMA-01-FY2 F05
5-D207A	ED-346440	D ZENER H HZ5FA F10 B1
5-D210A,211A	ED-624903	D SILICON H 1S2473
5-D212Ato215A	ED-346503	D ZENER H HZ20FA F10 2
5-VR201A	EV-321637	R S-FIX H D8 3P 104
5-FL201A	EH-337380	FILTER CE KMFC-1001S 3.580MHZ
5-FL202A	EH-347991	OSC CE CSA6.00MS 6.00000MC
5-FL203A	EH-347992	COMP C CSC300K
5-SR1A	EH-348115	COMP R RKC1/8B3 3.3K J
5-SR2A	EH-348117	COMP R RKC1/8B8D 47K J
5-SR3A	EH-347938	COMP R M-3744
5-SR5-1A,2A	EH-348114	COMP R RKC1/8B4 47K J
5-SR6-1A,2A	EH-348118	COMP C 05-0056
5-SR7A	EH-348119	COMP C 05-0057
5-R201A	ER-338235	R MF V 1/4W 1820F
5-R202A	ER-347939	R MF V 1/4W 1051F
5-R203A	ER-338234	R MF V 1/4W 1331F
5-R204A	ER-347940	R MF V 1/4W 2151F
5-R205A	ER-347941	R MF V 1/4W 3091F
5-R206A	ER-338231	R MF V 1/4W 5361F
5-R208A	ER-309788	R MF V 1/4W 1001F
REMO. CON. P.C BOARD		
5-J51C	EJ-344282	DIN J TCS1891-01-1011 P 8P

6. REC P.C BOARD BLOCK

REF. NO.	PARTS NO.	DESCRIPTION
REC P.C BOARD		
6-TR1A	ET-200558	TR 2SA1115 E,F
6-D1Ato8A	ED-344280	D SILICON H GMA-01-FY2 F05
6-D10A,11A	ED-344280	D SILICON H GMA-01-FY2 F05
6-D12A	ED-348135	D LED SR506D (4) RED
6-D13A,14A	ED-348137	D LED SG206D (4) GRN
6-D15Ato17A	ED-348135	D LED SR506D (4) RED
6-D18A	ED-344280	D SILICON H GMA-01-FY2 F05
6-D19A,20A	ED-348135	D LED SR506D (4) RED
6-D21A	ED-344280	D SILICON H GMA-01-FY2 F05
6-D22A	ED-348135	D LED SR506D (4) RED
6-D23A	ED-344280	D SILICON H GMA-01-FY2 F05
6-D24A	ED-348135	D LED SR506D (4) RED
6-D25A	ED-344280	D SILICON H GMA-01-FY2 F05
6-D26A	ED-348137	D LED SG206D (4) GRN
6-D27A	ED-344280	D SILICON H GMA-01-FY2 F05
6-D28A	ED-348137	D LED SG206D (4) GRN
6-D29A	ED-344280	D SILICON H GMA-01-FY2 F05
6-D30A	ED-348137	D LED SG206D (4) GRN
6-D31A	ED-344280	D SILICON H GMA-01-FY2 F05
6-SW1Ato18A	ES-336780	SW TACT KHH10902
6-SW19A	ES-348124	SW LEAF MSW-1127A 01-1NO
SLIDE MOTOR P.C BOARD		
6-TR1B	ET-328868	TR 2SD1012-V G,H
6-TR2B	ET-328868	TR 2SD1012-V G,H
6-TR3B,4B	ET-324134	TR 2SA984K E,F
6-D1B,2B	ED-344280	D SILICON H GMA-01-FY2 F05
6-L1B,2B	EO-669273	COIL FIX 2 FL5R200 180
SWITCH P.C BOARD		
6-SW1C	ES-691457	SW MICRO VV-SR
7. METER P.C BOARD BLOCK		
REF. NO.	PARTS NO.	DESCRIPTION
7-1	BA-T2049A130A	PC METER BLK GX-R99
7-IC1to4	EI-348105	IC HA12010
7-D1,2	ED-348122	D LED TLY143 YLW
7-D3,4	ED-348121	D LED TLG143 GRN
7-SW2to13	ES-336780	SW TACT KHH10902
7-SW15,16	ES-346260	SW PUSH SPH121A 2-02-02N
7-IN1	EM-348120	IND FL BG-152Z DOUBLE
7-R1	ER-315043	R CBH F10 RDS 1/4W 101J
7-R3	ER-346175	R MF H F10 1/4W 2003F
7-R4	ER-349158	R MF H F10 1/4W 3001F

8. POWER SUPPLY P.C BOARE BLOCK

REF. NO.	PARTS NO.	DESCRIPTION
8-1	BA-T2049A090A	PC POWER BLK GX-R99 (U)
8-2	BA-T2049A090B	PC POWER BLK GX-R99 (J)
8-3	BA-T2049A090C	PC POWER BLK GX-R99 (C)
		(C,A)
8-4	BA-T2049A090D	PC POWER BLK GX-R99 (E)
		(E,V,B,S)
8-IC1	EI-348123	IC M5230AL
8-IC2	EI-337529	IC TA78L005AP
8-IC4	EI-330352	IC BA6109
8-TR1	ET-337188	TR 2SB774 P,Q
8-TR2	ET-307349	TR 2SD794 P,Q
8-TR3	ET-328578	TR 2SC2320 E,F
8-TR4	ET-337968	TR 2SA999 E,F
8-TR5	ET-350816	TR 2SD549 E,F
8-TR6	ET-322598	TR 2SB632K E,F
8-TR7,8	ET-200505	TR 2SC2603 E,F
8-TR9	ET-554657	TR 2SA733A P,Q
8-TR10	ET-350948	TR 2SD612K F
8-TR11,12	ET-336997	TR 2SB808-V G,H
8-TR13,14	ET-347961	TR 2SD1012-V G
8-TR15,16	ET-336997	TR 2SB808-V G,H
8-TR17	ET-200505	TR 2SC2603 E,F
8-TR18	ET-328868	TR 2SD1012-V G,H
8-TR19	ET-200985	TR 2SC2603 F,G
8-TR20	ET-200505	TR 2SC2603 E,F
8-D1	ED-330987	D SILICON RB152 200/1.5A
8-D2,3	ED-330319	D SILICON DBA10B 100/1.0A
8-D4	ED-330622	D SILICON 1SR35-100VL
		100/1.0A
8-D5	ED-346505	D ZENER H HZ222FA F10 1
8-D6	ED-346454	D ZENER H HZ6FA F10 C3
8-D7,8	ED-624903	D SILICON H 1S2473
8-D9	ED-346473	D ZENER H HZ9FA F10 C3
8-D11	ED-624903	D SILICON H 1S2473
8-D12	ED-346462	D ZENER H HZ27FA F10 C2
8-D13	ED-346440	D ZENER H HZ5FA F10 B1
8-D14	ED-346446	D ZENER H HZ5FA F10 C3
8-SW1	ES-348998	SW PUSH SDL1P 01-1
8-R1,2	ER-347952	△ R OMF H S15 FS 1W 331J
8-R11	ER-352000	△ R OMF H S15 FS 1W 332J
8-R38	ER-337755	△ R OMF H S20 FS 2W 222J
8-FR1	ER-318248	△ R FUSE ERD2FC S10 1/4W
		47R0G
8-C1,2	EC-324664	C EC V CUT USM 222M 25.0DC
8-C16	EC-201761	C EC V CUT USM 472M 16.0DC
8-C24	EC-316186	C EC V CUT SM 222M 16.0DC
8-C30A	EC-337681	C MMY V ECQEW 223M 250AC
		(U)
8-C30B	EC-350949	C MMY V ECQ-E 223M 250DC(J)
8-C30C	EC-338397	C MMY V ECQUE 223M 125AC
		(C,A)
8-C30D	EC-338399	C MMY V ECQUF 223M 250AC
		(E,V,B,S)
8-F1Uto3U	EF-309387	△ FUSE TSC A 250V 1.00A(U,J)
8-F4U	EF-311839	△ FUSE TSC A 250V 1.60A(U,J)
8-F5J	EF-306124	△ FUSE TSC A 250V 0.63A (J)
8-F1Cto3C	EF-310229	△ FUSE TSC 125V 1.00A (C,A)
8-F4C	EF-308847	△ FUSE TSC 125V 1.60A (C,A)
8-F5C	EF-305703	△ FUSE TSC 125V 0.63A (C,A)
8-F1Eto3E	EF-623103	△ FUSE SEMKO T 250V 1.00A
		(E,V,B,S)
8-F4E	EF-601964	△ FUSE SEMKO T 250V 1.60A
		(E,V,B,S)
8-F5E	EF-601942	△ FUSE SEMKO T 250V 0.63A
		(E,V,B,S)

9. POWER SUPPLY (2) P.C BOARD BLOCK

REF. NO.	PARTS NO.	DESCRIPTION
9-IC1	EI-348123	IC M5230AL
9-TR1	ET-348950	TR 2SA1345
9-D1to4	ED-330622	D SILICON 1SR35-100VL
		100/1.0A
9-D5to8	ED-560913	D SILICON V 1S2473VE
9-C1,2	EC-333991	C EC V CUT NP SM 470M 25DC
9-C7	EC-331631	C STY V SNP CQFS 821J 50DC

10. MOTOR P.C BOARD BLOCK

REF. NO.	PARTS NO.	DESCRIPTION
MOTOR P.C BOARD		
10-IC1A,2A	EI-201940	IC NJM4558S
10-TR1A	ET-337011	TR 2SC2274K D,E
10-TR2A	ET-337012	TR 2SA984K D,E
10-TR3A	ET-337011	TR 2SC2274K D,E
10-TR4A	ET-337012	TR 2SA984K D,E
10-L3A,4A	EO-669273	COIL FIX 2 FL5R200 180
SERVO P.C BOARD		
10-IC1B	EI-336992	IC µPC1043C
10-IC2B	EI-310036	IC TC4066BP
10-IC3B	EI-201940	IC NJM4558S
10-TR1B	ET-200505	TR 2SC2603 E,F
10-TR2B	ET-337011	TR 2SC2274K D,E
10-TR3B	ET-337012	TR 2SA984K D,E
10-TR4B	ET-337011	TR 2SC2274K D,E
10-TR5B	ET-337012	TR 2SA984K D,E
10-D1Bto4B	ED-348001	D ZENER V HZ2B-1S7
10-D5B	ED-338082	D ZENER V HZ5C-1S7
10-VR1B	EV-341250	R S-FIX V TM8KH1-1S 3P
		0.50W 503
10-VR2B,3B	EV-336850	R S-FIX H KV5F807U 3P 202
10-R5B	ER-323487	R MF H F10 1/4W 1503F
10-R22B	ER-333703	R CB H S15 FS RDS 1/2W 911J
10-C4B	EC-347590	C COMP V AWS 273J 50DC

SLIDE CASE BLOCK

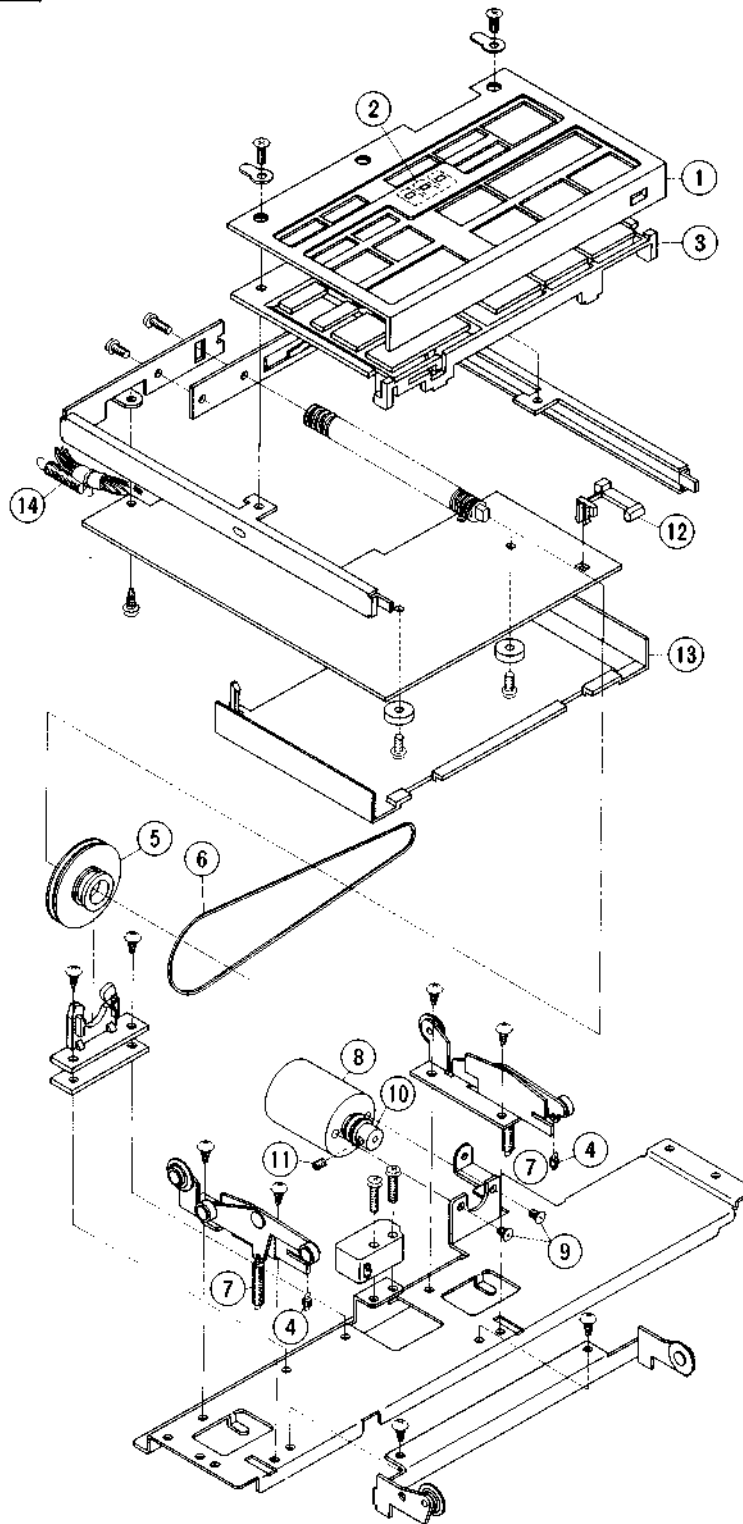

11. SLIDE CASE BLOCK

REF. NO.	PARTS NO.	DESCRIPTION	REF. NO.	PARTS NO.	DESCRIPTION
11-1	SP-345239B	PANEL OPERATION-B	11-8	BM-345196	MOTOR RF-280S
11-2	EM-345245B	INDICATOR (1)	11-9	ZS-430413	CTS26x04STL CMT
11-3	SK-P345241	HOLDER BUTTON PART	11-10	MR-345200	PULLEY MOTOR
11-4	ZG-349269	ST T2-3.2/0.29-8.0 T2-056	11-11	ZS-318234	6SET30x030SCM PKR WP
11-5	MR-345212	PULLEY DRIVE	11-12	SK-345277	KNOB DOOR
11-6	MB-345201	BELT	11-13	SP-345242	COVER SUB CASE
11-7	ZG-350891	SP T2-4.0/0.4-22.4 T2-114	11-14	ZG-313031	SP T1-5.0/0.32-28.0 T1-144

ASSEMBLY BLOCK

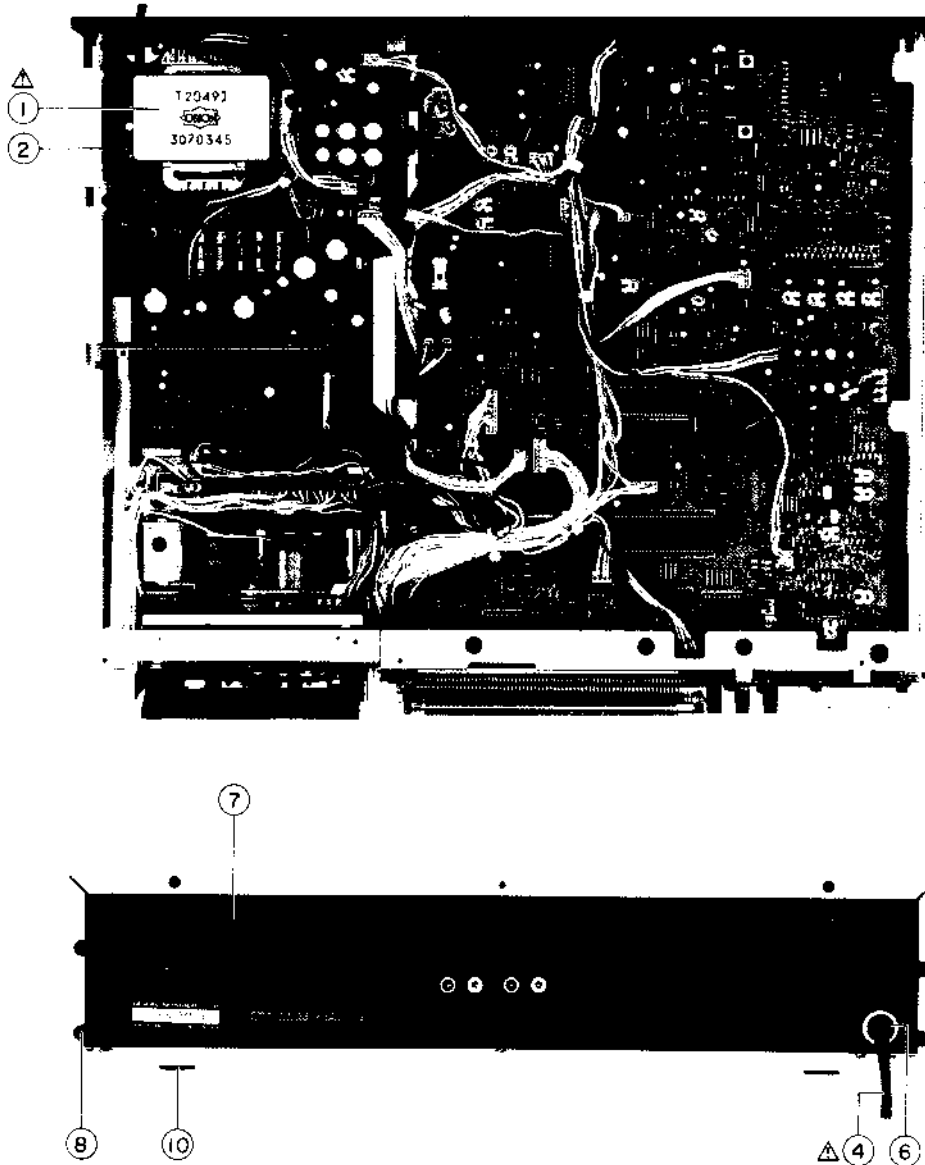

12. ASSEMBLY BLOCK

REF. NO.	PARTS NO.	DESCRIPTION	REF. NO.	PARTS NO.	DESCRIPTION
	TRANS POWER BLOCK				
12-1U	BT-348082	△ TRANS POWER T2049U	12-6B	EJ-692908	STRAIN RELIEF SR-5N-4 (B)
12-1J	BT-348083	△ TRANS POWER T2049J		ASSEMBLY BLOCK	
12-1A	BT-348084	△ TRANS POWER T2049AC	*12-7U	SP-345237A	PANEL REAR GX-R99 (U)
12-1E	BT-348085	△ TRANS POWER T2049EV	*12-7J	SP-345237B	PANEL REAR GX-R99 (J)
12-1B	BT-348086	△ TRANS POWER T2049BS	*12-7C	SP-345237C	PANEL REAR GX-R99 (C,A)
12-2	ZS-301398	ST BID40x08STL CMT	*12-7E	SP-345237D	PANEL REAR GX-R99 (E)
12-3x	ZW-413188	N40STL CMT 1	*12-7V	SP-345237E	PANEL REAR GX-R99 (V)
12-4U	EW-374894	AC CORD 2 CORES VM-0129A, VFF U/T (U)	*12-7B	SP-345237F	PANEL REAR GX-R99 (B,S)
12-4J	EW-351961	AC CORD 2 CORES KP-211 VFF J (J)	12-8	ZS-345272	ST BR30x06STL BNI
12-4C	EW-207742	AC CORD 2 CORES VM-0238, SPT-1 UC (C,A)	12-9	ZG-350793	SP EARTH
12-4E	EW-347897	AC CORD 2 CORES VM0364, LCFL EV (E,V)	12-10	SA-349332	FOOT
12-4B	EW-347828	AC NR BS 42/0.15x2 EV (B)	12-11	ZS-320906	ST BR30x06STL CMT
12-4S	EW-347898	AC CORD 2 CORES VM-0436, LCFL S (S)	12-12x	ZW-305013	RV POP32 (A)
12-5U	ES-305733	SW SELECTOR HXW0131-260 01-4 (U)			
12-6U	EZ-631945	STRAIN RELIEF SR-4N-4 (U,J,C,A,E,V,S)			

NOTE: Panel, Rear (Ref. No. 12-7) and Cover, Upper (Ref. No. 13-12). Due to the change in the screw mounting locations effective in Nov. 1983, replace both these parts together, when intending to replace either one in the product built in before Oct. 1983. Presently only the new parts are being supplied.

FINAL ASSEMBLY BLOCK

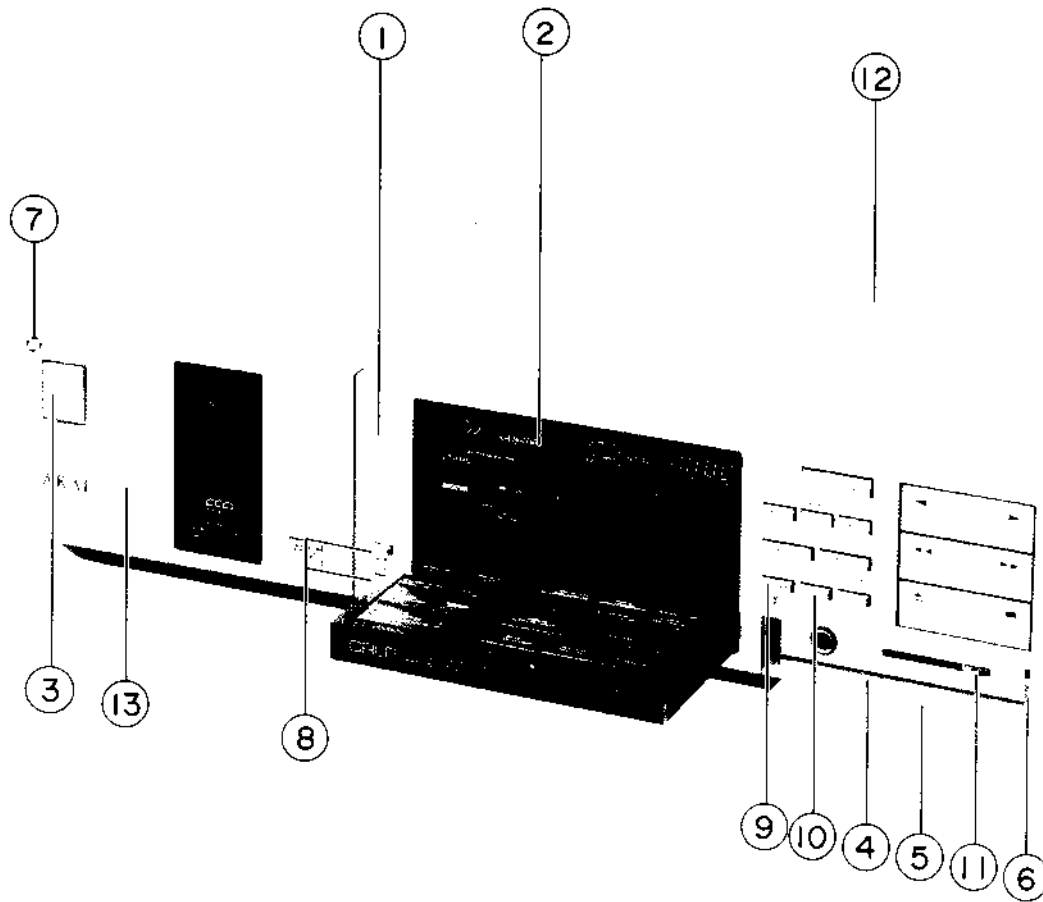

13. FINAL ASSEMBLY BLOCK

REF. NO.	PARTS NO.	DESCRIPTION
FRONT PANEL BLOCK		
13-1S	BD-T2049A160A	PANEL FRONT BLK GX-R99
13-1P	BD-T2049A160B	PANEL FRONT BLK GX-R99-P
13-1B	BD-T2049A160C	PANEL FRONT BLK GX-R99-B
13-2	SZ-345234	WINDOW METER
13-3S	SK-B345231A	KNOB POWER-PART
13-3P	SK-B345231B	KNOB POWER-P PART
13-3B	SK-B345231C	KNOB POWER-B PART
13-4	SP-345228B	DOOR PHONE-P
13-4B	SP-345228C	DOOR PHONE-B
13-5S	SP-345226A	PANEL PHONE
13-5P	SP-345226B	PANEL PHONE-P
13-5B	SP-345226C	PANEL PHONE-B
13-6	TP-345229	HINGE DOOR
13-7S	MB-330911	CUCHEON RUBBER
13-7P	MB-330911B	CUCHEON RUBBER (BL)

SYMBOL FOR COLOR VARIATION

S — SILVER
 P — PEARL SHADOW
 B or BL — BLACK

REF. NO.	PARTS NO.	DESCRIPTION
FINAL ASSEMBLY BLOCK		
13-8S	SK-351574A	KNOB TIMER
13-8P	SK-351574B	KNOB TIMER-P
13-8B	SK-351574C	KNOB TIMER-B
13-9S	SK-B345233A1	KNOB DOLBY-1 PART
13-9P	SK-B345233A3	KNOB DOLBY-1P PART
13-9B	SK-B345233A4	KNOB DOLBY-1B PART
13-10S	SK-B345233A2	KNOB DOLBY-2 PART
13-10P	SK-B345233A5	KNOB DOLBY-2P PART
13-10B	SK-B345233A6	KNOB DOLBY-2B PART
13-11S	SK-343009D	KNOB OUTPUT-S
13-11P	SK-343009B	KNOB OUTPUT-P
13-11B	SK-343009C	KNOB OUTPUT-B
*13-12S	BC-345243A	COVER UPPER
*13-12P	BC-345243B	COVER UPPER-P
*13-12B	BC-345243C	COVER UPPER-B
13-13S	BD-B345247A	LID PANEL PART
13-13P	BD-B345247B	LID PANEL-P PART
13-13B	BD-B345247C	LID PANEL-B PART

NOTE: Panel, Rear (Ref. No. 12-7) and Cover, Upper (Ref. No. 13-12). Due to the change in the screw mounting locations effective in Nov. 1983, replace both these parts together, when intending to replace either one in the product built in before Oct. 1983. Presently only the new parts are being supplied.

INDEX

PARTS NO.	REF. NO.	PARTS NO.	REF. NO.	PARTS NO.	REF. NO.	PARTS NO.	REF. NO.
AV-332302	3-BT1	EC-350679	4-C9A	ED-344280	3-D42	ED-348001	10-D1B
BA-T2048A080B	4-1A	EC-350680	3-C18	ED-344280	3-D43	ED-348001	10-D2B
BA-T2049A090A	8-1	EC-350949	8-C30B	ED-344280	3-D44	ED-348001	10-D3B
BA-T2049A090B	8-2	EC-351992	4-C92A	ED-344280	3-D45	ED-348001	10-D4B
BA-T2049A090C	8-3	EC-351992	4-C93A	ED-344280	3-D46	ED-348121	7-D3
BA-T2049A090D	8-4	EC-351992	4-C14A	ED-344280	3-D47	ED-348121	7-D4
BA-T2049A130A	7-1	EC-351993	4-C94A	ED-344280	3-D48	ED-348122	7-D1
BA-T2049A140A	5-1	EC-351993	4-C15A	ED-344280	3-D49	ED-348122	7-D2
BA-T2049A150A	3-1	EC-351993	4-C64A	ED-344280	3-D50	ED-348135	6-D16A
BC-345243A	13-12S	EC-351994	4-C71A	ED-344280	3-D51	ED-348135	6-D17A
BC-345243B	13-12P	EC-351995	4-C98A	ED-344280	3-D56	ED-348135	6-D19A
BC-345243C	13-12B	EC-351995	4-C20A	ED-344280	3-D59	ED-348135	6-D20A
BD-B345247A	13-13S	EC-351996	3-C16	ED-344280	3-D81	ED-348135	6-D22A
BD-B348464	1-81	EC-351998	3-C23	ED-344280	3-D82	ED-348135	6-D24A
BD-T2049A160A	13-1S	EC-351999	3-C104	ED-344280	3-D83	ED-348135	6-D12A
BD-T2049A160B	13-1P	EC-352006	3-C25	ED-344280	3-D84	ED-348135	6-D15A
BD-T2049A160C	13-1B	EC-352006	3-C103	ED-344280	3-D85	ED-348137	6-D26A
BF-B345189	2-42	EC-352007	3-C21	ED-344280	3-D86	ED-348137	6-D28A
BF-B345190	2-43	EC-352007	3-C22	ED-344280	3-D87	ED-348137	6-D30A
BH-T2049A070A	1-2	EC-352008	3-C110	ED-344280	3-D89	ED-348137	6-D13A
BL-B336007X1	2-6	EC-352009	4-C70A	ED-344280	3-D90	ED-348137	6-D14A
BL-B336009	2-10	ED-200468	4-D14A	ED-344280	3-D80	ED-560913	9-D7
BL-B345159	2-20	ED-200468	4-D16A	ED-344280	3-D92	ED-560913	9-D8
BL-T2049A050A	1-27	ED-308952	4-D11A	ED-344280	3-D93	ED-560913	9-D5
BL-T2049A060A	1-32	ED-308952	4-D12A	ED-344280	4-D2A	ED-560913	9-D6
BM-B604526	2-35	ED-330319	8-D2	ED-344280	4-D3A	ED-624903	3-D95
BM-B604527	2-38	ED-330319	8-D3	ED-344280	4-D4A	ED-624903	5-D210A
BM-M3105A010A	2-1	ED-330622	8-D4	ED-344280	4-D7A	ED-624903	5-D211A
BM-345196	11-8	ED-330622	9-D1	ED-344280	4-D8A	ED-624903	8-D8
BR-T2049A040A	1-26	ED-330622	9-D3	ED-344280	4-D9A	ED-624903	8-D11
BT-348082	12-1U	ED-330622	9-D4	ED-344280	4-D10A	ED-624903	8-D7
BT-348083	12-1J	ED-330622	9-D2	ED-344280	5-D204A	EF-305703	8-F5C
BT-348084	12-1A	ED-330987	8-D1	ED-344280	6-D18A	EF-306124	8-F5J
BT-348085	12-1E	ED-336998	3-D20	ED-344280	6-D21A	EF-308847	8-F4C
BT-348086	12-1B	ED-337019	1-82	ED-344280	6-D23A	EF-309387	8-F1U
BZ-T2030A110A	1-83	ED-337867	3-D19	ED-344280	6-D25A	EF-309387	8-F2U
BZ-T2049A020A	1-1	ED-337867	3-D94	ED-344280	6-D27A	EF-309387	8-F3U
EA-345195	2-46	ED-338082	10-D5B	ED-344280	6-D29A	EF-310229	8-F1C
EC-200948	3-C72	ED-338453	3-D21	ED-344280	6-D31A	EF-310229	8-F2C
EC-200948	3-C73	ED-338453	3-D22	ED-344280	6-D1B	EF-310229	8-F3C
EC-200948	3-C70	ED-338453	3-D23	ED-344280	6-D2B	EF-311839	8-F4U
EC-200948	3-C71	ED-338453	3-D24	ED-344280	6-D1A	EF-601942	8-F5E
EC-200948	3-C95	ED-344280	3-D1	ED-344280	6-D2A	EF-601964	8-F4E
EC-201021	3-C54	ED-344280	3-D2	ED-344280	6-D3A	EF-623103	8-F3E
EC-201761	8-C16	ED-344280	3-D3	ED-344280	6-D4A	EF-623103	8-F2E
EC-300193	3-C82	ED-344280	3-D4	ED-344280	6-D5A	EF-623103	8-F1E
EC-300193	3-C7	ED-344280	3-D5	ED-344280	6-D6A	EH-336775	4-FL2A
EC-300193	3-C8	ED-344280	3-D6	ED-344280	6-D7A	EH-336776	4-FL1A
EC-300193	3-C9	ED-344280	3-D7	ED-344280	6-D8A	EH-336776	4-FL4A
EC-300193	3-C13	ED-344280	3-D8	ED-344280	6-D10A	EH-337380	5-FL201A
EC-307684	3-C35	ED-344280	3-D9	ED-344280	6-D11A	EH-347938	5-SR3A
EC-312012	3-C100	ED-344280	3-D10	ED-346440	5-D207A	EH-347991	5-FL202A
EC-316186	8-C24	ED-344280	3-D11	ED-346440	8-D13	EH-347992	5-FL203A
EC-318314	4-C84A	ED-344280	3-D12	ED-346445	3-D91	EH-348114	5-SR5-1A
EC-324664	8-C1	ED-344280	3-D14	ED-346446	8-D14	EH-348114	5-SR5-2A
EC-324664	8-C2	ED-344280	3-D15	ED-346454	8-D6	EH-348115	5-SR1A
EC-328774	3-C53	ED-344280	3-D16	ED-346462	8-D12	EH-348117	5-SR2A
EC-331631	9-C7	ED-344280	3-D17	ED-346473	8-D9	EH-348118	5-SR6-1A
EC-332052	3-C117	ED-344280	3-D25	ED-346478	4-D5A	EH-348118	5-SR6-2A
EC-332052	3-C118	ED-344280	4-D13A	ED-346493	4-D1A	EH-348119	5-SR7A
EC-333991	9-C1	ED-344280	4-D15A	ED-346503	5-D212A	EI-201940	10-IC1A
EC-333991	9-C2	ED-344280	5-D201A	ED-346503	5-D213A	EI-201940	10-IC2A
EC-337681	8-C30A	ED-344280	5-D202A	ED-346503	5-D214A	EI-201940	10-IC3B
EC-338397	8-C30C	ED-344280	5-D203A	ED-346503	5-D215A	EI-304657	3-IC1
EC-338399	8-C30D	ED-344280	3-D26	ED-346505	8-D5	EI-305456	3-IC5
EC-338435	3-C56	ED-344280	3-D27	ED-346633	4-D6A	EI-307644	4-IC3A
EC-338435	3-C57	ED-344280	3-D28	ED-347767	3-D72	EI-310036	3-IC21
EC-338506	4-C85A	ED-344280	3-D29	ED-347768	3-D18	EI-310036	10-IC2B
EC-338506	4-C8A	ED-344280	3-D30	ED-347768	3-D52	EI-328593	4-IC4A
EC-341409	4-C65A	ED-344280	3-D31	ED-347768	3-D53	EI-330352	8-IC4
EC-343855	3-C96	ED-344280	3-D32	ED-347768	3-D54	EI-336761	3-IC10
EC-344486	3-C24	ED-344280	3-D33	ED-347768	3-D55	EI-336761	3-IC11
EC-347590	10-C4B	ED-344280	3-D34	ED-347768	3-D57	EI-336761	3-IC12
EC-348273	3-C55	ED-344280	3-D35	ED-347768	3-D58	EI-336761	3-IC13
EC-348292	3-VC1	ED-344280	3-D36	ED-347768	3-D60	EI-336761	3-IC14
EC-348293	3-C52	ED-344280	3-D37	ED-347768	3-D61	EI-336761	3-IC22
EC-348300	3-FL3	ED-344280	3-D38	ED-347768	3-D62	EI-336761	3-IC24
EC-350679	3-C12	ED-344280	3-D39	ED-347768	3-D78	EI-336761	3-IC25
EC-350679	3-C20	ED-344280	3-D40	ED-347768	3-D76	EI-336761	3-IC27
EC-350679	4-C87A	ED-344280	3-D41	ED-347768	3-D63	EI-336761	3-IC28

INDEX

PARTS NO.	REF. NO.	PARTS NO.	REF. NO.	PARTS NO.	REF. NO.	PARTS NO.	REF. NO.
EI-336761	3-IC29	ER-302156	4-R117A	ES-691457	6-SW1C	ET-324134	6-TR3B
EI-336761	3-IC30	ER-302157	3-R84	ET-200505	3-TR14	ET-324134	6-TR4B
EI-336761	3-IC31	ER-309788	5-R208A	ET-200505	3-TR15	ET-328578	3-TR94
EI-336761	3-IC32	ER-315043	7-R1	ET-200505	3-TR16	ET-328578	8-TR3
EI-336761	3-IC33	ER-318248	8-FR1	ET-200505	3-TR35	ET-328868	3-TR12
EI-336761	3-IC34	ER-323487	10-R5B	ET-200505	3-TR36	ET-328868	3-TR13
EI-336761	3-IC35	ER-331188	3-FR2	ET-200505	3-TR37	ET-328868	3-TR22
EI-336761	4-IC6A	ER-331188	3-FR1	ET-200505	3-TR38	ET-328868	3-TR43
EI-336761	4-IC8A	ER-333703	10-R22B	ET-200505	3-TR39	ET-328868	3-TR46
EI-336761	4-IC5A	ER-337755	8-R38	ET-200505	3-TR40	ET-328868	3-TR60
EI-336761	5-IC210A	ER-338183	4-R108A	ET-200505	3-TR41	ET-328868	3-TR56
EI-336761	5-IC211A	ER-338231	5-R206A	ET-200505	3-TR42	ET-328868	3-TR57
EI-336987	2-51	ER-338234	5-R203A	ET-200505	3-TR49	ET-328868	3-TR58
EI-336992	10-IC1B	ER-338235	5-R201A	ET-200505	3-TR50	ET-328868	3-TR59
EI-337008	5-IC204A	ER-346175	7-R3	ET-200505	3-TR61	ET-328868	3-TR66
EI-337008	5-IC205A	ER-347939	5-R202A	ET-200505	3-TR61	ET-328868	3-TR67
EI-337013	3-IC17	ER-347940	5-R204A	ET-200505	3-TR64	ET-328868	3-TR69
EI-337013	5-IC206A	ER-347941	5-R205A	ET-200505	3-TR70	ET-328868	3-TR73
EI-337013	5-IC207A	ER-347952	8-R1	ET-200505	3-TR77	ET-328868	3-TR74
EI-337013	5-IC208A	ER-347952	8-R2	ET-200505	3-TR79	ET-328868	3-TR78
EI-337017	3-FL2	ER-347957	4-R121A	ET-200505	3-TR80	ET-328868	3-TR81
EI-337126	4-IC7A	ER-347957	4-R124A	ET-200505	3-TR82	ET-328868	5-TR211A
EI-337228	3-IC2	ER-347957	4-R122A	ET-200505	3-TR83	ET-328868	5-TR210A
EI-337237	3-IC37	ER-347958	4-R111A	ET-200505	3-TR86	ET-328868	5-TR218A
EI-337360	3-IC23	ER-347958	4-R112A	ET-200505	3-TR87	ET-328868	6-TR1B
EI-337360	3-IC26	ER-347959	4-R116A	ET-200505	3-TR89	ET-328868	6-TR2B
EI-337360	4-IC9A	ER-348130	4-R113A	ET-200505	3-TR90	ET-328868	8-TR18
EI-337529	3-IC38	ER-348130	4-R114A	ET-200505	3-TR91	ET-330270	4-TR19A
EI-337529	8-IC2	ER-348272	3-FR3	ET-200505	3-TR92	ET-330270	4-TR4A
EI-338171	5-IC212A	ER-348272	3-FR4	ET-200505	3-TR96	ET-330270	4-TR16A
EI-338171	5-IC213A	ER-349158	7-R4	ET-200505	3-TR1	ET-330270	4-TR1A
EI-338171	5-IC214A	ER-350688	3-R83	ET-200505	3-TR2	ET-330270	4-TR22A
EI-338238	3-IC9	ER-350808	4-FR1A	ET-200505	5-TR214A	ET-330270	4-TR21A
EI-338238	3-IC15	ER-352000	8-R11	ET-200505	5-TR209A	ET-330270	4-TR27A
EI-338238	3-IC18	ER-520863	4-R40A	ET-200505	5-TR215A	ET-330270	4-TR36A
EI-338416	3-IC20	ER-559192	4-R77A	ET-200505	8-TR8	ET-330270	4-TR20A
EI-345765	3-IC3	ER-559192	4-R78A	ET-200505	8-TR17	ET-330270	4-TR6A
EI-345765	3-IC4	ES-305733	12-5U	ET-200505	8-TR20	ET-336997	5-TR217A
EI-345765	3-IC8	ES-336780	6-SW15A	ET-200505	8-TR7	ET-336997	8-TR16
EI-345765	3-IC19	ES-336780	6-SW1A	ET-200505	10-TR1B	ET-336997	8-TR15
EI-347923	3-IC39	ES-336780	6-SW2A	ET-200558	3-TR11	ET-336997	8-TR12
EI-348104	3-IC7	ES-336780	6-SW4A	ET-200558	3-TR25	ET-336997	8-TR11
EI-348105	3-IC16	ES-336780	6-SW5A	ET-200558	3-TR55	ET-337011	10-TR4B
EI-348105	7-IC1	ES-336780	6-SW6A	ET-200558	3-TR63	ET-337011	10-TR2B
EI-348105	7-IC2	ES-336780	6-SW7A	ET-200558	3-TR7	ET-337011	10-TR1A
EI-348105	7-IC3	ES-336780	6-SW10A	ET-200558	3-TR8	ET-337011	10-TR3A
EI-348105	7-IC4	ES-336780	6-SW11A	ET-200558	3-TR9	ET-337012	10-TR2A
EI-348106	3-IC36	ES-336780	6-SW8A	ET-200558	3-TR10	ET-337012	10-TR4A
EI-348108	5-IC201A	ES-336780	6-SW12A	ET-200558	3-TR68	ET-337012	10-TR5B
EI-348110	5-IC203A	ES-336780	6-SW13A	ET-200558	3-TR71	ET-337012	10-TR3B
EI-348111	5-IC209A	ES-336780	6-SW16A	ET-200558	3-TR72	ET-337112	4-TR30A
EI-348123	8-IC1	ES-336780	6-SW17A	ET-200558	3-TR88	ET-337188	8-TR1
EI-348123	9-IC1	ES-336780	6-SW18A	ET-200558	3-TR93	ET-337234	4-TR28A
EI-348701	4-IC2A	ES-336780	6-SW3A	ET-200558	3-TR95	ET-337968	8-TR4
EI-349196	4-IC1A	ES-336780	6-SW9A	ET-200558	3-TR3	ET-338410	3-TR21
EI-349196	4-IC10A	ES-336780	6-SW14A	ET-200558	3-TR4	ET-341400	3-TR24
EI-352230	3-IC6	ES-336780	7-SW7	ET-200558	3-TR5	ET-341400	4-TR9A
EI-352232	5-IC202A	ES-336780	7-SW3	ET-200558	3-TR6	ET-341400	4-TR11A
EJ-344282	5-J51C	ES-336780	7-SW2	ET-200558	5-TR216A	ET-341400	4-TR10A
EJ-348160	4-J5B	ES-336780	7-SW4	ET-200558	6-TR1A	ET-345091	1-68
EJ-351899	4-J1A	ES-336780	7-SW5	ET-200985	8-TR19	ET-347961	8-TR14
EJ-692908	12-6B	ES-336780	7-SW6	ET-307349	4-TR3A	ET-347961	8-TR13
SZ-345234	13-2	ES-336780	7-SW8	ET-307349	8-TR2	ET-347969	5-TR212A
EM-345245B	11-2	ES-336780	7-SW9	ET-308976	3-TR45	ET-347969	5-TR213A
EM-348120	7-IN1	ES-336780	7-SW10	ET-308976	3-TR52	ET-348302	3-TR65
EO-315758	3-FL1	ES-336780	7-SW12	ET-310341	1-71	ET-348950	4-TR13A
EO-331280	4-VL1F	ES-336780	7-SW11	ET-310833	3-TR47	ET-348950	4-TR17A
EO-331280	4-VL1G	ES-336780	7-SW13	ET-310833	3-TR48	ET-348950	4-TR15A
EO-336738	4-FL5A	ES-336990	1-69	ET-310833	3-TR54	ET-348950	4-TR24A
EO-336738	4-FL3A	ES-336990	2-30	ET-310833	3-TR53	ET-348950	4-TR26A
EO-337055	3-L1	ES-337427	1-85	ET-318237	3-TR44	ET-348950	9-TR1
EO-343768	3-L2	ES-344253	1-62	ET-319638	5-TR204A	ET-349080	4-TR31A
EO-343768	3-L3	ES-344253	1-64	ET-319638	5-TR206A	ET-349080	4-TR34A
EO-348100	3-T1	ES-344257	1-61	ET-319638	5-TR201A	ET-349080	4-TR32A
EO-348101	3-T2	ES-344257	1-63	ET-319638	5-TR205A	ET-349081	1-TR30
EO-669273	6-L1B	ES-346260	7-SW15	ET-319638	5-TR203A	ET-349081	1-TR31
EO-669273	6-L2B	ES-346260	7-SW16	ET-319638	5-TR202A	ET-349081	1-TR33
EO-669273	10-L3A	ES-348124	6-SW19A	ET-321016	4-TR2A	ET-349081	1-TR32
EO-669273	10-L4A	ES-348133	4-SW1C	ET-322598	3-TR51	ET-349081	1-TR75
EQ-344440	3-RL1	ES-348998	8-SW1	ET-322598	8-TR6	ET-349081	1-TR76

INDEX

PARTS NO.	REF. NO.	PARTS NO.	REF. NO.	PARTS NO.	REF. NO.	PARTS NO.	REF. NO.
ET-349081	3-TR34	ML-344949	1-34	ZG-349029	2-17		
ET-349081	3-TR84	ML-344950	1-36	ZG-349030	1-29		
ET-349081	3-TR85	ML-344953	1-59	ZG-349033	1-74		
ET-349081	3-TR97	ML-344954	1-60	ZG-349034	1-75		
ET-349081	3-TR23	ML-344955	1-65	ZG-349177	1-41		
ET-349081	3-TR26	ML-344961	1-47	ZG-349178	1-31		
ET-349081	3-TR27	ML-345073	1-44	ZG-349269	11-4		
ET-349081	3-TR28	ML-345074	1-46	ZG-350793	12-9		
ET-349081	3-TR29	ML-345173	2-28	ZG-350891	11-7		
ET-349081	4-TR7A	MP-344980	1-28	ZS-245147	1 7		
ET-349081	4-TR14A	MR-B345184	2-32	ZS-301398	12-2		
ET-349081	4-TR29A	MR-336019	2-44	ZS-310337	1-86		
ET-349081	4-TR37A	MR-345200	11-10	ZS-318234	11-11		
ET-349718	4-TR8A	MR-345212	11-5	ZS-320906	12-11		
ET-349725	4-TR35A	MT-305793	1-55	ZS-321194	2-47		
ET-349725	4-TR33A	MV-666887	1-70	ZS-336613	1-73		
ET-350795	4-TR12A	MZ-B345155	2-16	ZS-344001	1-9		
ET-350795	4-TR18A	MZ-336005	2-4	ZS-345272	12-8		
ET-350795	4-TR23A	MZ-344004	1-11	ZS-345773	1 23		
ET-350795	4-TR25A	MZ345165	2-23	ZS-422076	2-50		
ET-350806	4-TR5A	MZ-345169	2-8	ZS-430413	11-9		
ET-350816	8-TR5	MZ-345170	2-19	ZS-432843	2-15		
ET-350948	8-TR10	SA-349332	12-10	ZS-432843	2-5		
ET-554657	5-TR207A	SK-B345231A	13-3S	ZS-460440	1-67		
ET-554657	8-TR9	SK-B345231B	13-3P	ZS-460440	2-31		
EV-315412	3-VR12	SK-B345231C	13-3B	ZS-477876	2-12		
EV-315413	3-VR5	SK-B345233A1	13-9S	ZS-477887	2-49		
EV-315413	3-VR8	SK-B345233A2	13-10S	ZS-477887	2-40		
EV-315413	3-VR9	SK-B345233A3	13-9P	ZS-481645	1-18		
EV-315414	3-VR20	SK-B345233A4	13-9B	ZS-524812	1-24		
EV-315414	3-VR19	SK-B345233A5	13-10P	ZS-592378	2-39		
EV-315414	3-VR17	SK-B345233A6	13-10B	ZS-592378	2-36		
EV-315414	3-VR18	SK-B345241	11-3	ZW-259650	1-77		
EV-315414	3-VR11	SK-343009B	13-11P	ZW-259661	2-33		
EV-315414	3-VR6	SK-343009C	13-11B	ZW 270088	1-78		
EV-315416	3-VR4	SK-343009D	13-11S	ZW-270088	1-84		
EV-315416	3-VR1	SK-345277	11-12	ZW-270088	2-24		
EV-315416	3-VR13	SK-351574A	13-8S	ZW-270088	2-18		
EV-315416	3-VR7	SK-351574B	13-8P	ZW-270088	2-29		
EV-321637	3-TR10	SK-351574C	13-8B	ZW-270123	2-26		
EV-321637	5-VR201A	BD-B345247B	13-13P	ZW-270134	2-22		
EV-325994	4-VR6A	BD-B345247C	13-13B	ZW-273734	1-10		
EV-330531	3-VR3	SP-336163	1-79	ZW-282407	2-34		
EV-330531	3-VR2	SP-345226A	13-5S	ZW-305013	12-12x		
EV-336850	10-VR3B	SP-345226B	13-5P	ZW-329422	1-57		
EV-336850	10-VR2B	SP-345226C	13-5B	ZW-329422	1-50		
EV-337052	2-3	SP-345228B	13-4	ZW-329422	1-45		
EV-337841	4-VR1D	SP-345228C	13-4B	ZW-330073	1-54		
EV-337993	4-VR3A	SP-345237A	12-7U	ZW-336603	2-13		
EV-337995	4-VR2A	SP-345237B	12-7J	ZW-336603	2-7		
EV-338588	4-VR5A	SP-345237C	12-7C	ZW-336604	2-21		
EV-341250	10-VR1B	SP-345237D	12-7E	ZW-336604	2-9		
EV-345297	4-VR4	SP-345237E	12-7V	ZW-344639G	1-21		
EV-351222	3-VR14	SP-345237F	12-7B	ZW-350766B	1-20		
EW-207742	12-4C	SP-345239B	11-1	ZW-350839	1-76		
EW-347828	12-4B	SP-345242	11-13	ZW-350890	1-30		
EW-347897	12-4E	SZ-336166	1-33	ZW-356657	1-43		
EW-347898	12-4S	TC-B345187	2-14	ZW-391397	1-13		
EW-351961	12-4J	TC-B345188	2-2	ZW-413188	12-3x		
EW-374894	12-4U	TC-336142	1-53	ZW-618884	1-16		
EZ-631945	12-6U	TC-336146	1-35				
HE-H2302A010A	1-14	TC-336161	1-56				
HE-H2303A010A	1-15	TC-344942	1-17				
HP-H2404A010A	1-5	TC-344982	1-58				
HZ-B344006	1-6	TC-345181	2-48				
HZ-B344009	1-4	TP-345229	13-6				
HZ-344011	1-8	ZG-312946	1-37				
HZ-344015	1-22	ZG-312998	1-66				
HZ-349298	1-72	ZG-313002	2-25				
MA-B344940	1-3	ZG-313031	11-14				
MB-330911	13-7S	ZG-336011	2-11				
MB-330911B	13-7P	ZG-336141	1-52				
MB-344989	2-45	ZG-336615	1-80				
MB-345179	2-37	ZG-344012	1-12				
MB-345193	2-41	ZG-344960	1-51				
MB-345201	11-6	ZG-344964	1-49				
MI-T2049A030A	1-25	ZG-344984	2-27				
ML-B344951	1-38	ZG-344985	1-42				
ML-B344952	1-40	ZG-344987	1-39				
ML-B344962	1-48	ZG-344988	1-19				

HA17408P

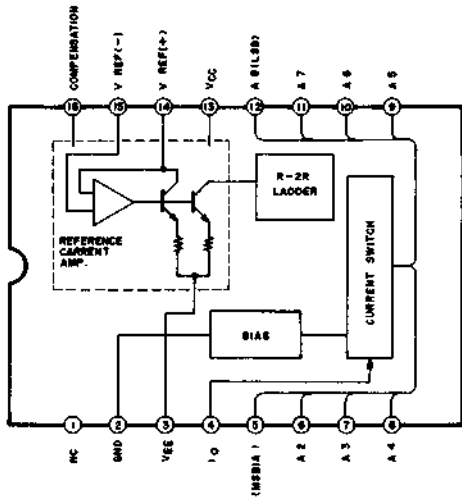

M51133P

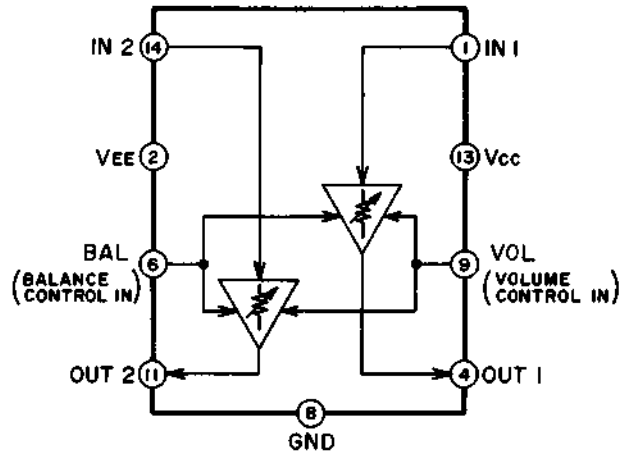

M5L8243P

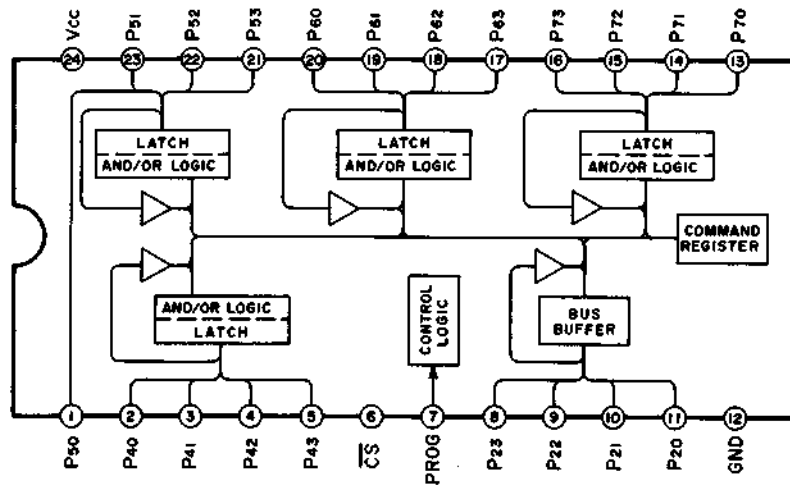

M50780SP

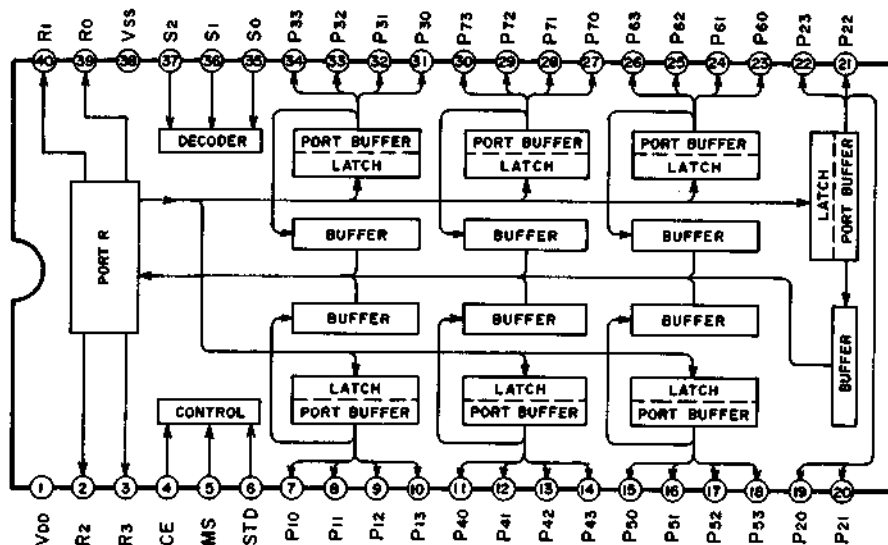

SECTION 4

SCHEMATIC DIAGRAM

TABLE OF CONTENTS

1. SCHEMATIC DIAGRAM OF ICs	69
2. OVERALL BLOCK DIAGRAM	73
3. CONNECTION DIAGRAM	74
4. POWER SUPPLY SCHEMATIC DIAGRAM	75
5. SYSTEM CONTROL BLOCK DIAGRAM	76
6. SYSTEM CONTROL SCHEMATIC DIAGRAM	77
7. PRE AMP BLOCK DIAGRAM	78
8. PRE AMP SCHEMATIC DIAGRAM	79
9. MECHA BLOCK SCHEMATIC DIAGRAM	80
10. TUNING BLOCK DIAGRAM	81
11. TUNING (2-1) SCHEMATIC DIAGRAM	82
12. TUNING (2-2) SCHEMATIC DIAGRAM	83
13. METER SCHEMATIC DIAGRAM	84

BA6109

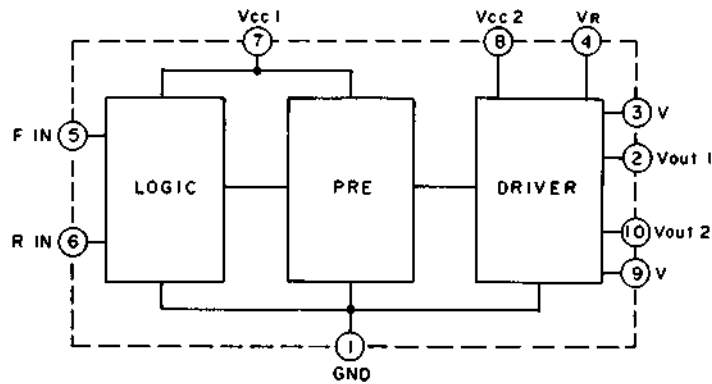

HA12010

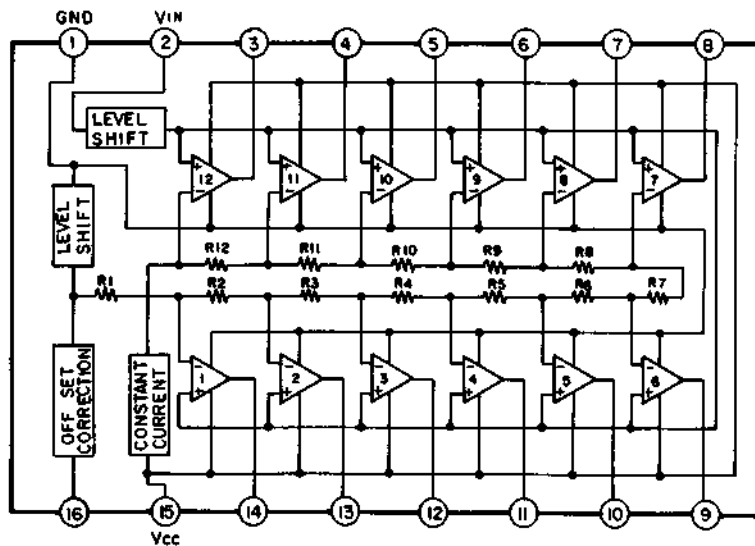

μ PD4051BC

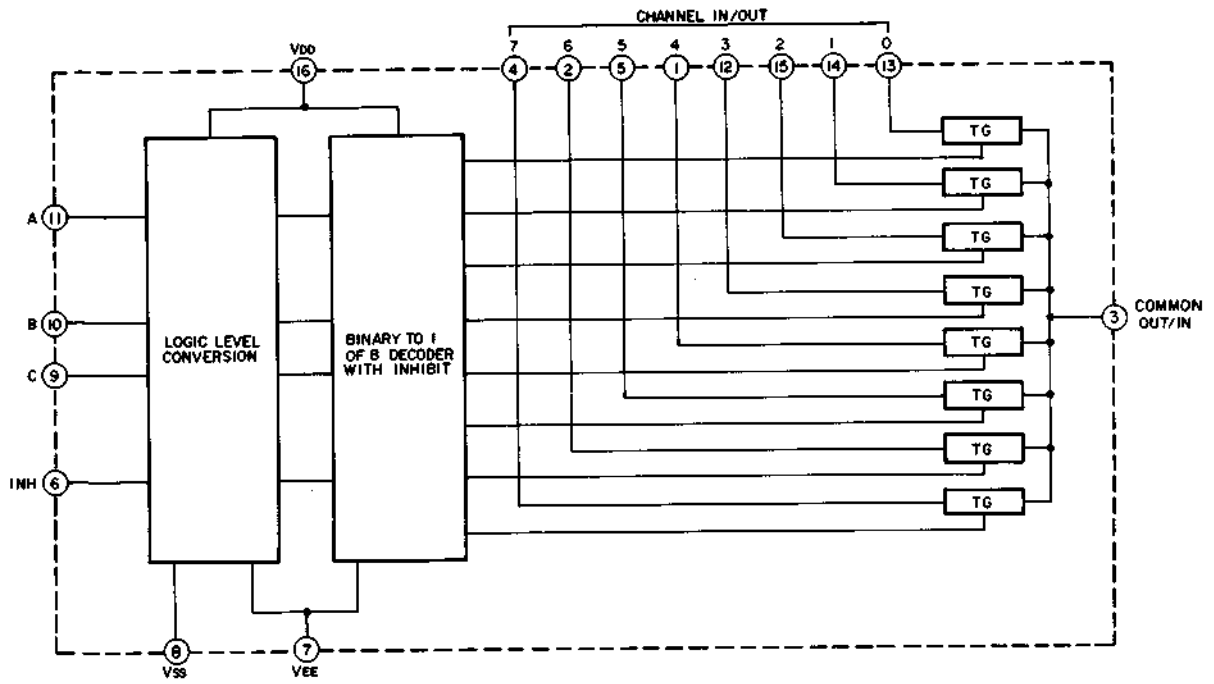

μ PC1043C

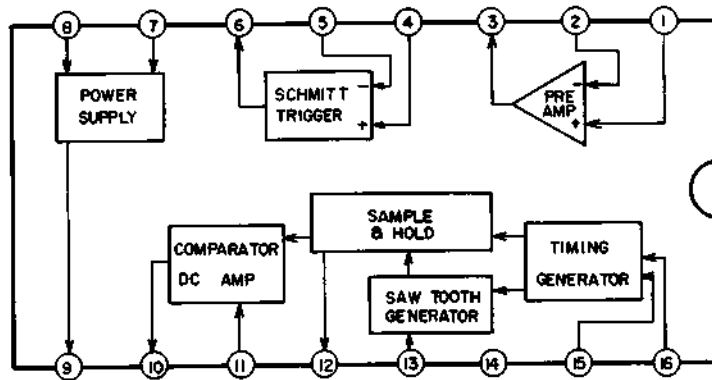

TC4066BP

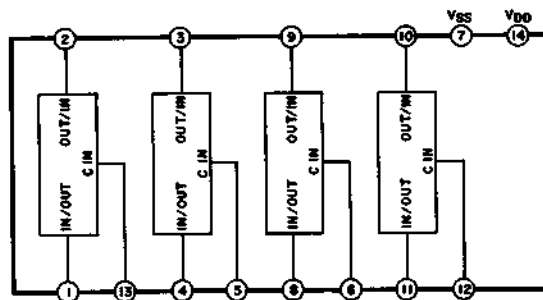

C IN	IMPEDANCE BETWEEN IN/OUT - OUT/IN
H	0.5 to 5×10^2 OHMS
L	MORE THAN 10^9 OHMS

M5230AL

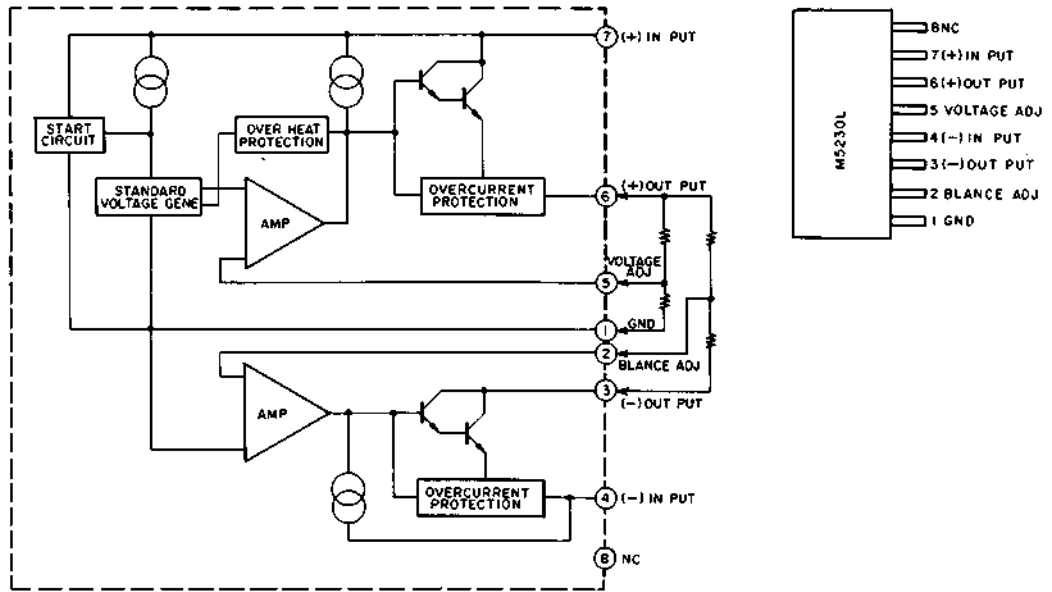

LC7800

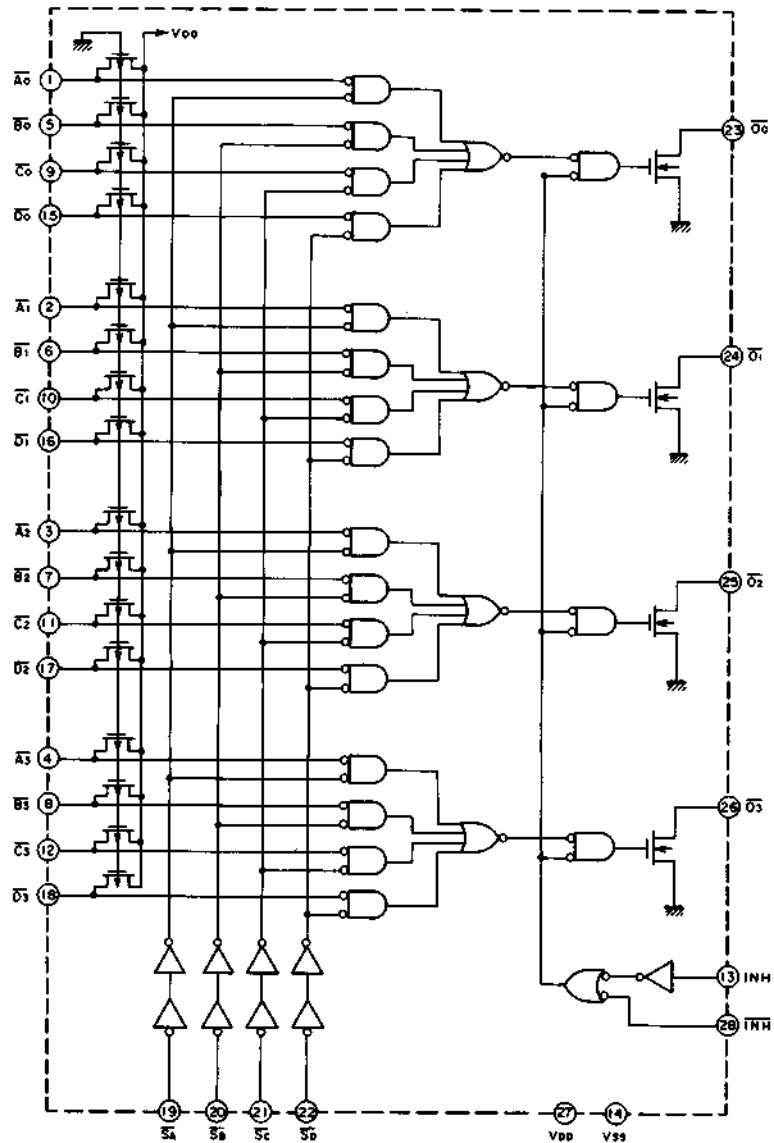

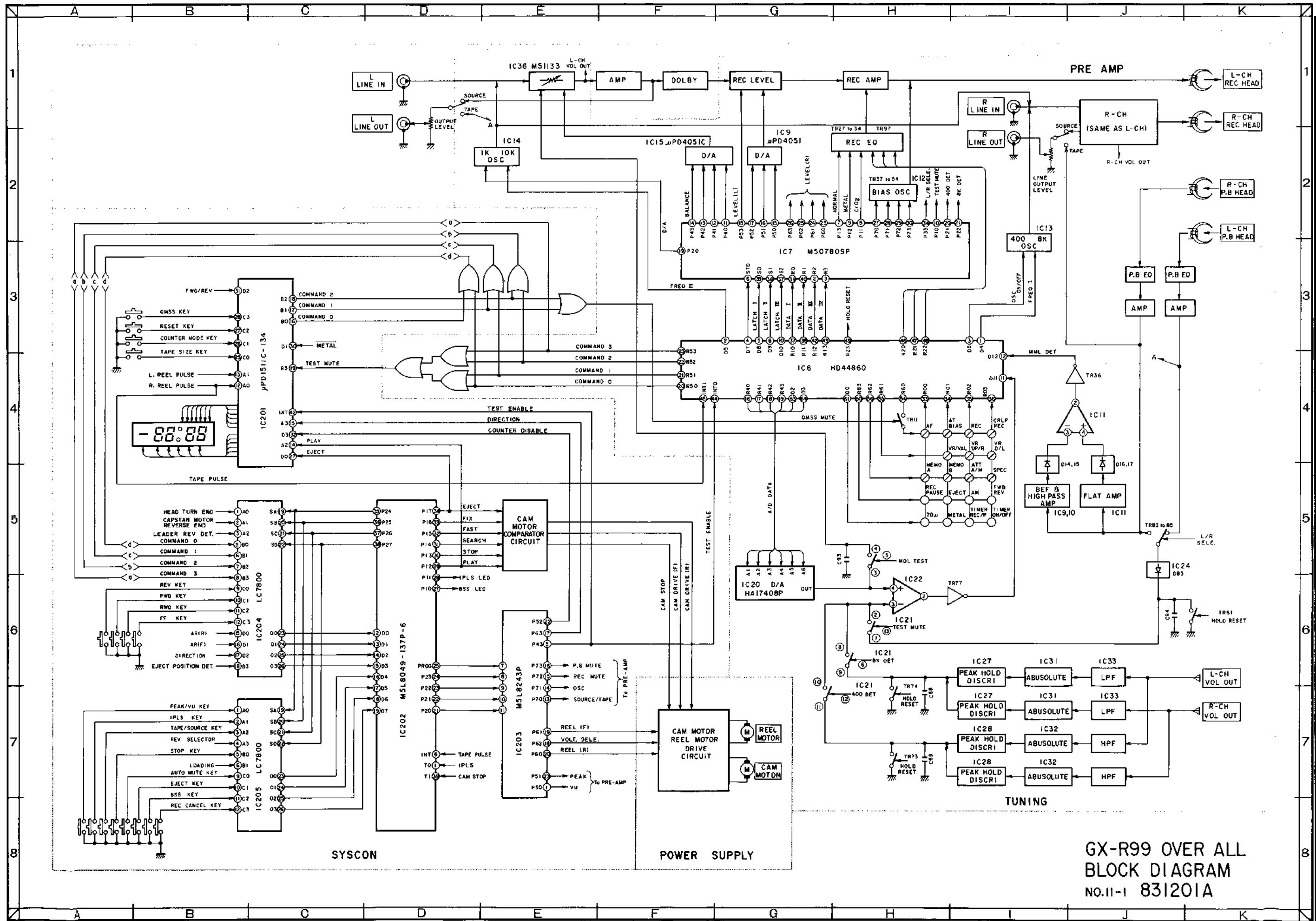

GX-R99 OVER ALL
BLOCK DIAGRAM
NO.11-1 831201A

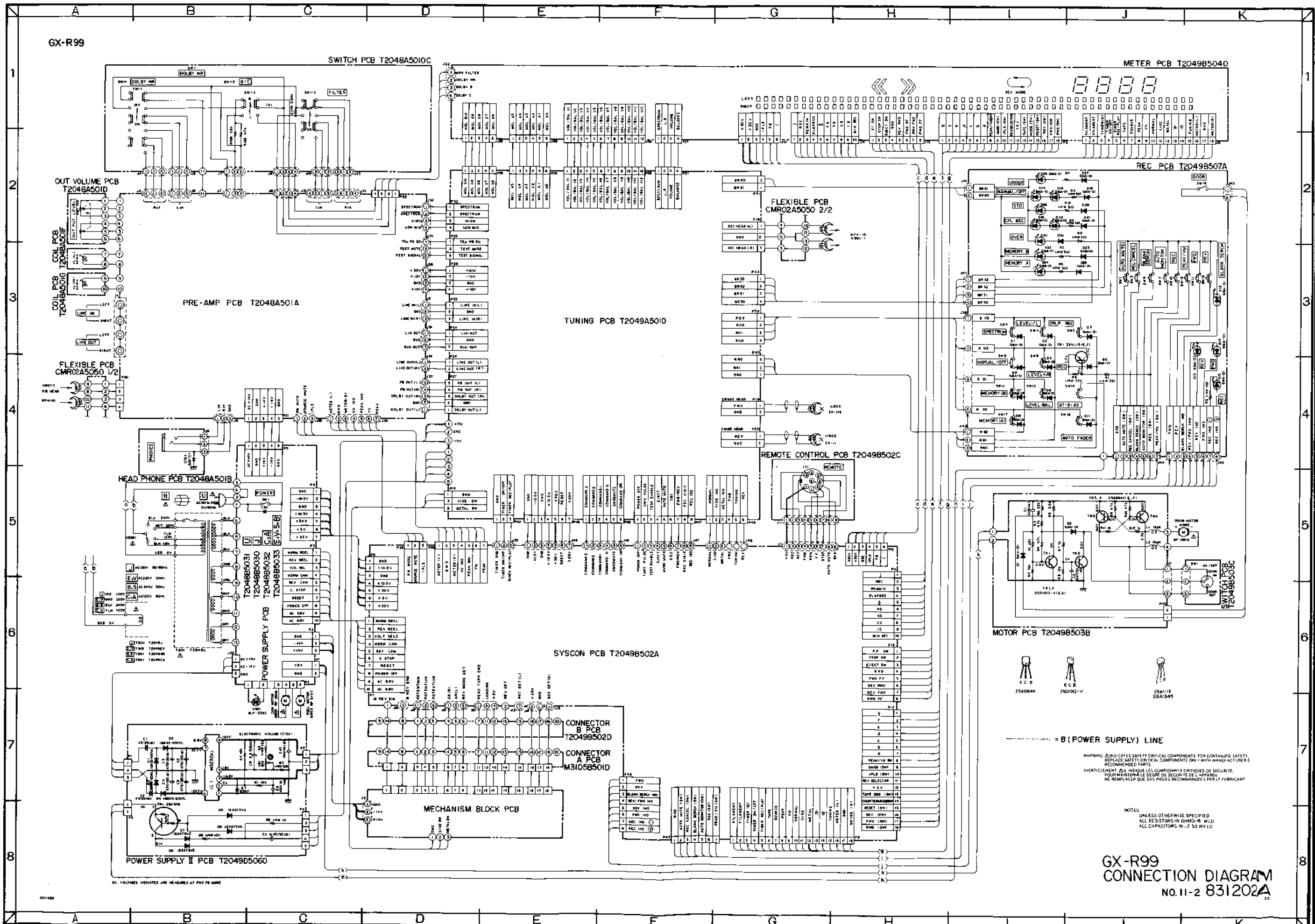

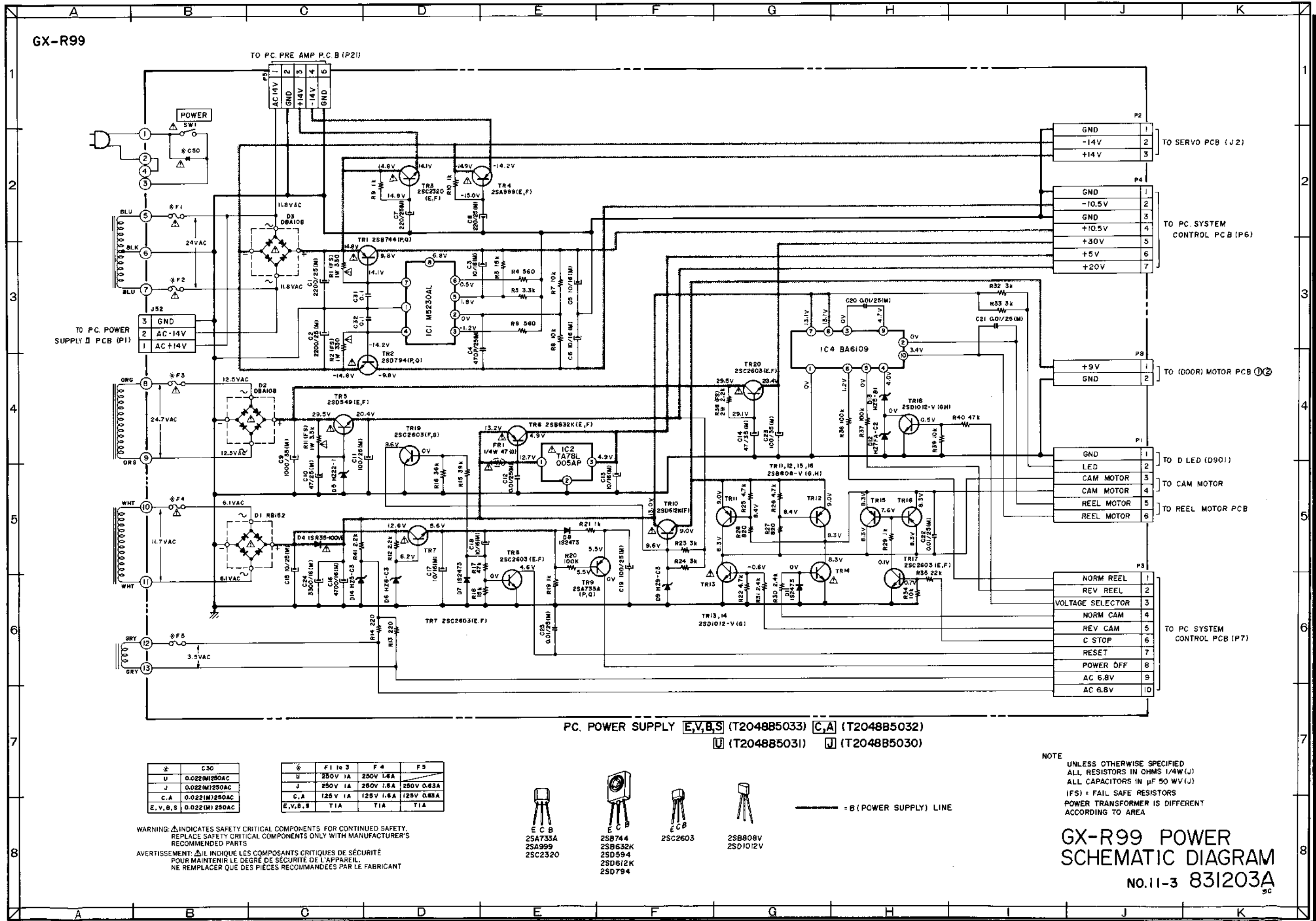

GX-R99

TO PC. PRE AMP P.C.B (P2)

TO PC. POWER SUPPLY PCB (P1)

TO SERVO PCB (J2)

TO PC SYSTEM CONTROL PCB (P6)

TO (DOOR) MOTOR PCB (1,2)

TO D LED (D901)

TO CAM MOTOR

CAM MOTOR

REEL MOTOR

TO REEL MOTOR PCB

TO PC SYSTEM CONTROL PCB (P7)

PC. POWER SUPPLY E,V,B,S (T2048B5033) C,A (T2048B5032)
 U (T2048B5031) J (T2048B5030)

⊗	C30
U	0.022(M)250AC
J	0.022(M)250AC
C,A	0.022(M)250AC
E,V,B,S	0.022(M)250AC

⊗	F1 to 3	F4	F5
U	250V 1A	250V 1.4A	
J	250V 1A	250V 1.8A	250V 0.63A
C,A	125V 1A	125V 1.6A	125V 0.63A
E,V,B,S	T1A	T1A	T1A

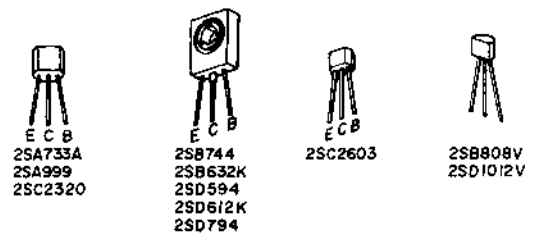

NOTE
 UNLESS OTHERWISE SPECIFIED
 ALL RESISTORS IN OHMS 1/4W(J)
 ALL CAPACITORS IN μF 50 WV(J)
 (FS) = FAIL SAFE RESISTORS
 POWER TRANSFORMER IS DIFFERENT
 ACCORDING TO AREA

WARNING: Δ INDICATES SAFETY CRITICAL COMPONENTS. FOR CONTINUED SAFETY, REPLACE SAFETY CRITICAL COMPONENTS ONLY WITH MANUFACTURER'S RECOMMENDED PARTS.
 AVERTISSEMENT: Δ IL INDIQUE LES COMPOSANTS CRITIQUES DE SÉCURITÉ. POUR MAINTENIR LE DEGRÉ DE SÉCURITÉ DE L'APPAREIL, NE REMPLACER QUE DES PIÈCES RECOMMANDÉES PAR LE FABRICANT.

GX-R99 POWER SCHEMATIC DIAGRAM
 No.11-3 831203A

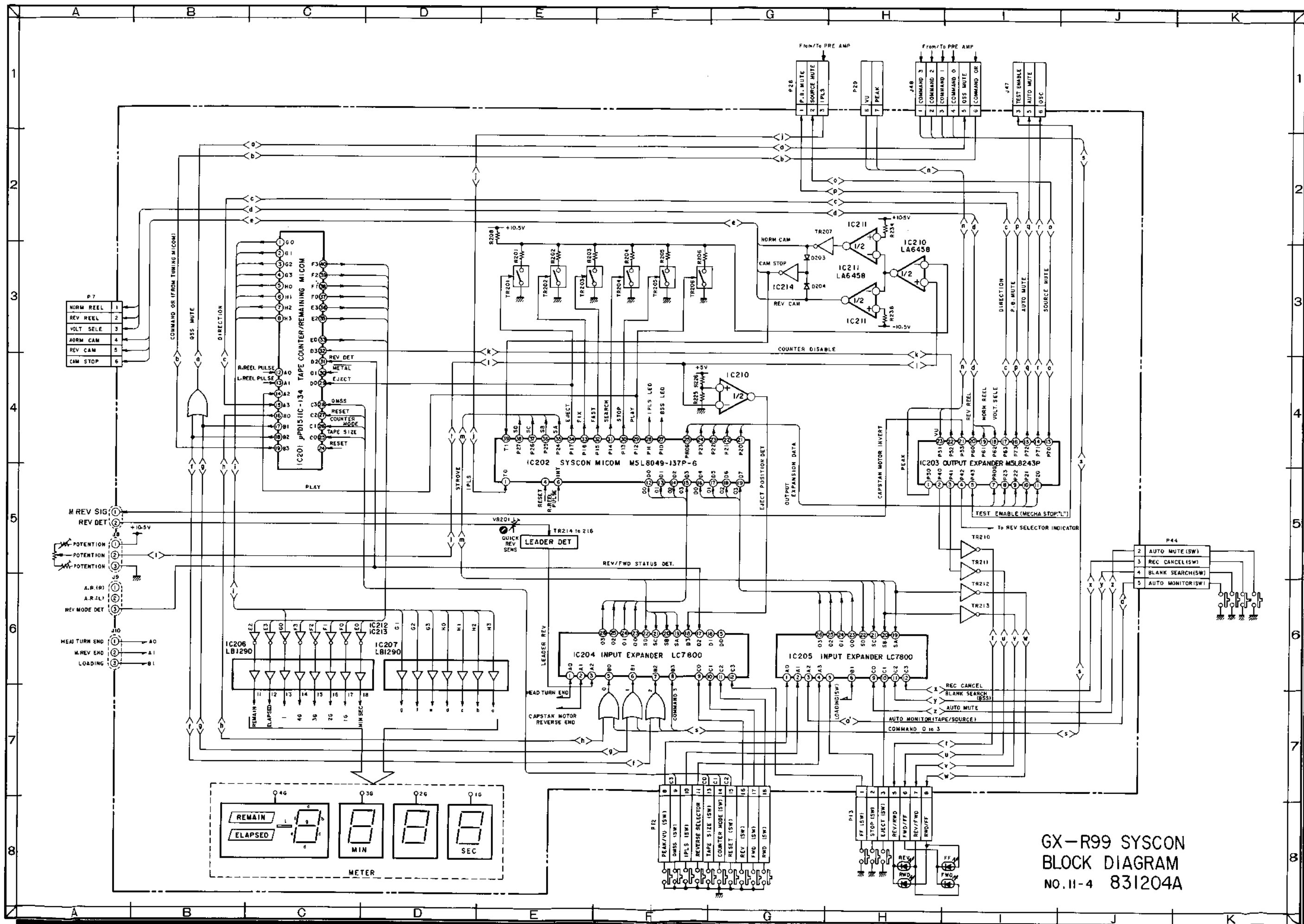

GX-R99 SYSCON
BLOCK DIAGRAM
NO.11-4 831204A

GX-R99

SYSCON PCB T2049B502A

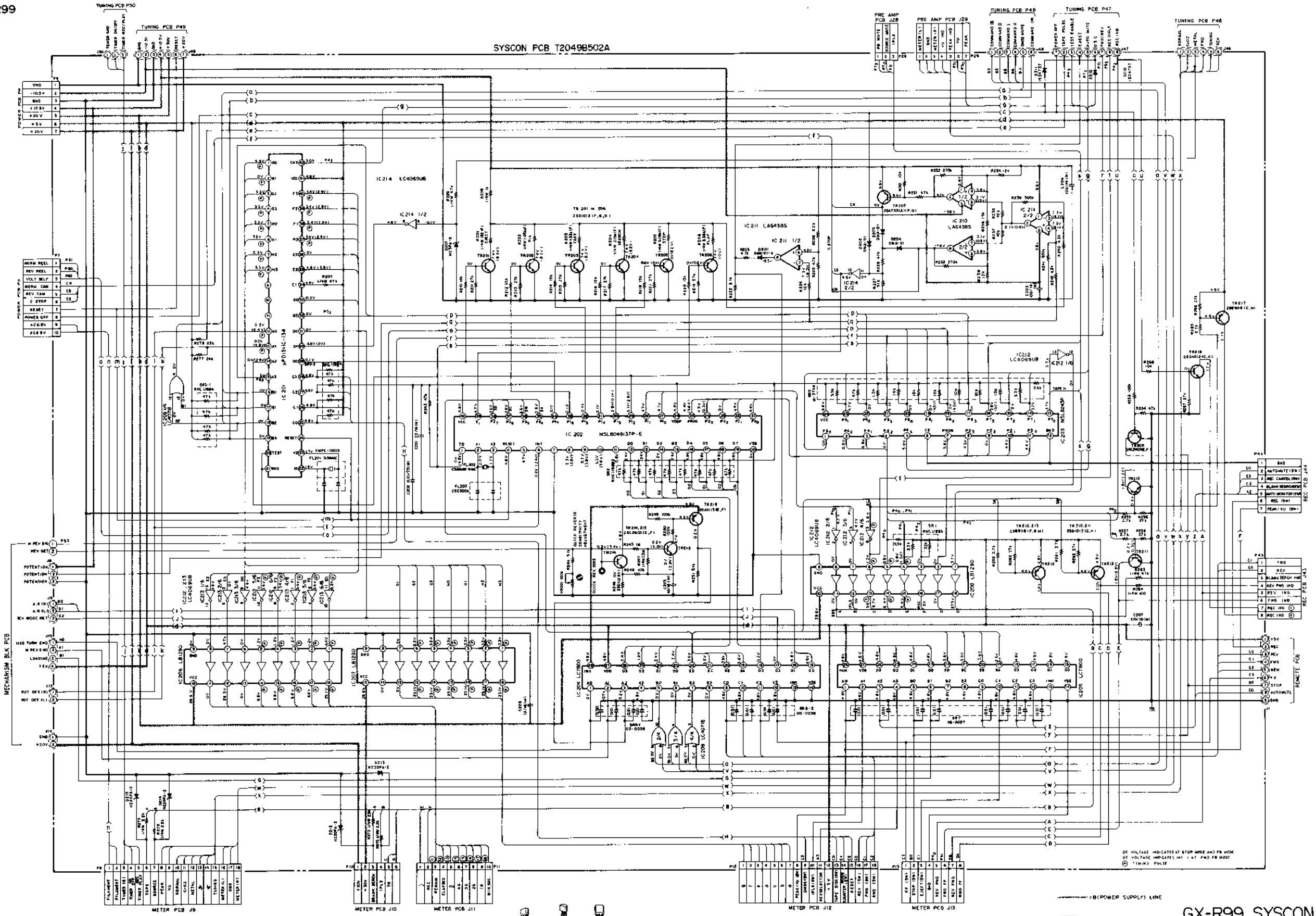

MECHANISM BLK PCB

METER PCB J9

METER PCB J10

METER PCB J11

METER PCB J12

METER PCB J13

DC VOLTAGE INDICATES STOP MODE AND PW MODE
 DC VOLTAGE INDICATES INT 1 AT PW MODE
 () TUNING PULSE

NOTES
 UNLESS OTHERWISE SPECIFIED
 ALL RESISTORS IN OHMS (R/W/L)
 ALL CAPACITORS IN .150 WV/11

GX-R99 SYSCON
 SCHEMATIC DIAGRAM
 NO.11-5 831205A

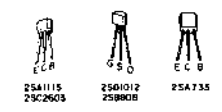

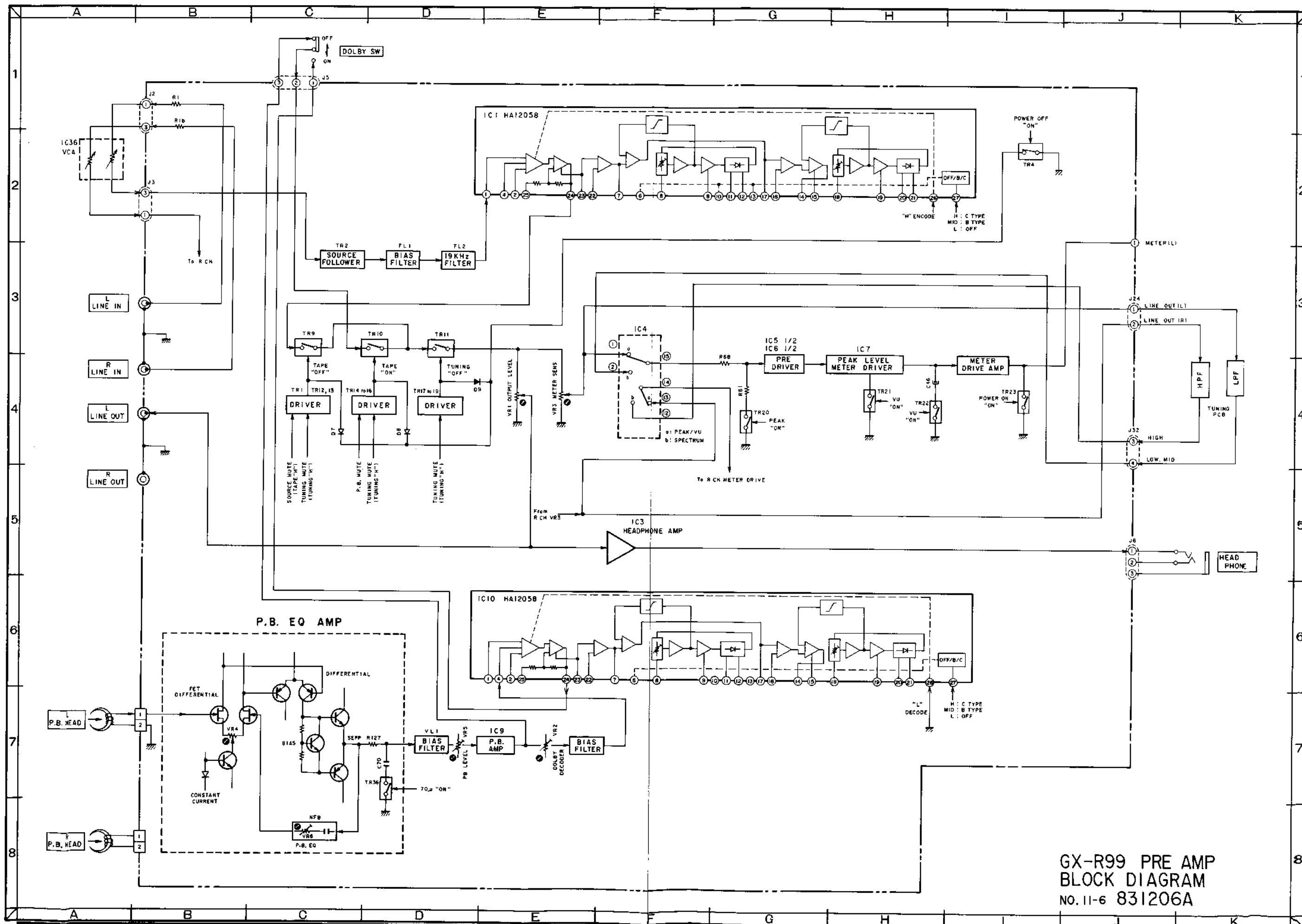

GX-R99 PRE AMP
BLOCK DIAGRAM
NO. 11-6 831206A

GX-R99

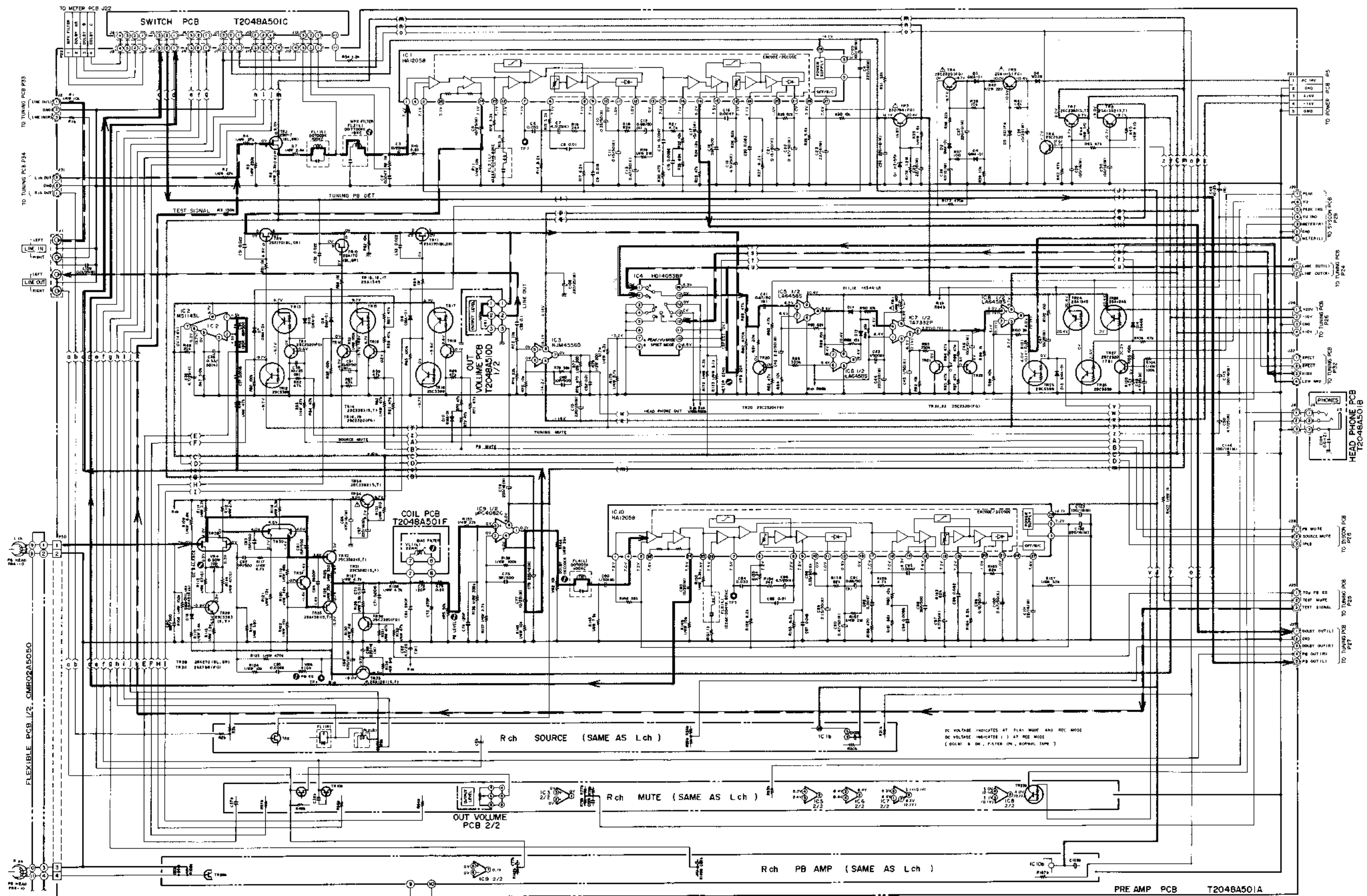

* B (POWER SUPPLY) LINE
 METER DRIVE SIGNAL LINE
 SOURCE SIGNAL LINE
 SPECTRUM HIGH SIGNAL LINE
 SPECTRUM LOW, W.D. SIGNAL LINE
 PB SIGNAL LINE
 TUNING TEST SIGNAL LINE
 REC SIGNAL LINE



WARNING: INDICATES SAFETY CRITICAL COMPONENTS FOR CONTINUED SAFETY. REPLACE SAFETY CRITICAL COMPONENTS ONLY WITH MANUFACTURER'S RECOMMENDED PARTS.
 AVERTISSEMENT: INDICATE LES COMPOSANTS CRITIQUES DE SECURITE. POUR MAINTENIR UN NIVEAU DE SECURITE, SEULEMENT LES PIECES RECOMMANDEES PAR LE FABRICANT.

NOTES
 UNLESS OTHERWISE SPECIFIED
 ALL RESISTORS IN OHMS (1/4W, 1%)
 ALL CAPACITORS IN P.F. (50 WVV)

GX-R99 PRE AMP SCHEMATIC DIAGRAM
 NO.11-7 831207A

GX-R99

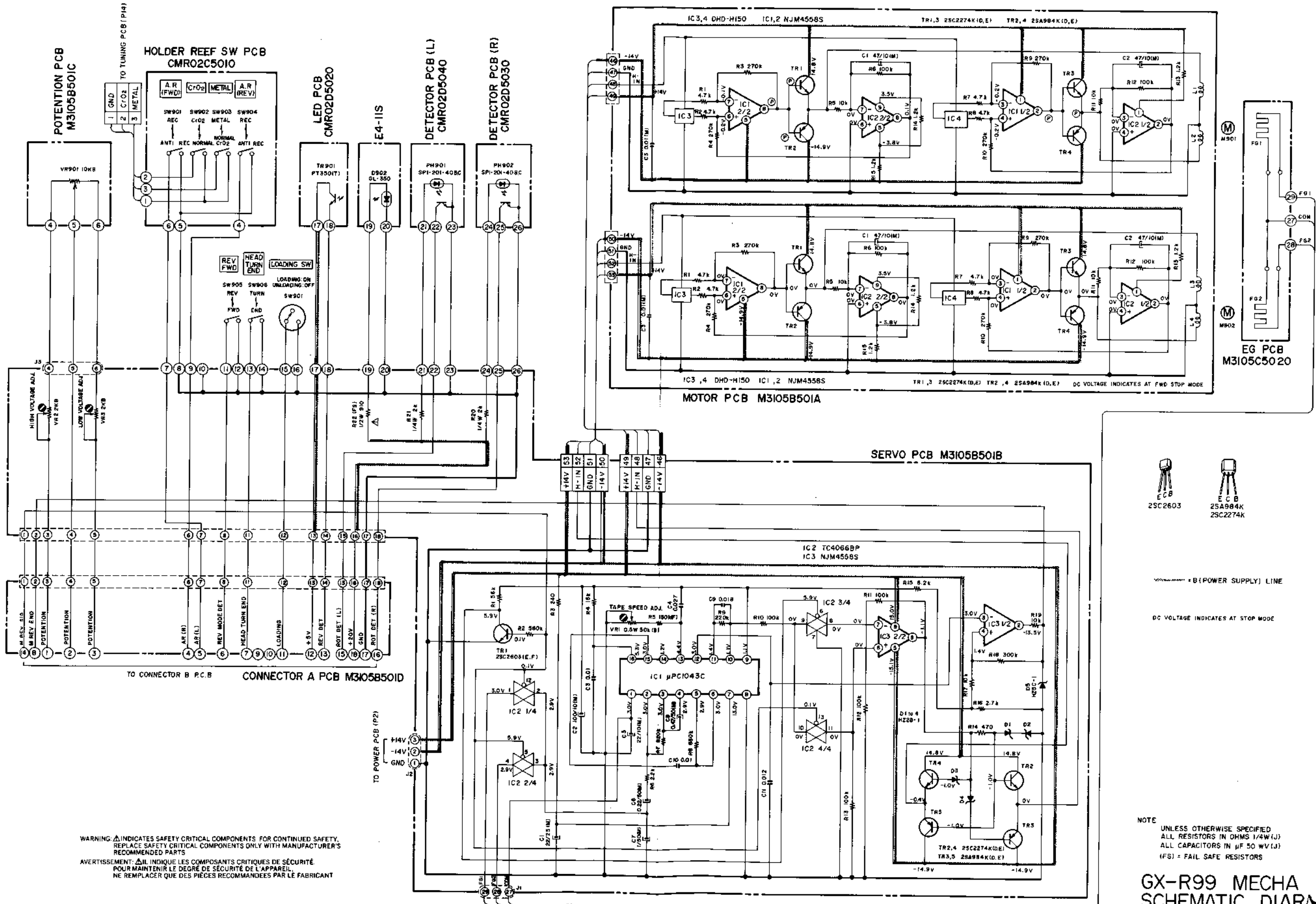

WARNING: Δ INDICATES SAFETY CRITICAL COMPONENTS. FOR CONTINUED SAFETY, REPLACE SAFETY CRITICAL COMPONENTS ONLY WITH MANUFACTURER'S RECOMMENDED PARTS.
 AVERTISSEMENT: Δ IL INDIQUE LES COMPOSANTS CRITIQUES DE SÉCURITÉ. POUR MAINTENIR LE DEGRÉ DE SÉCURITÉ DE L'APPAREIL, NE REMPLACER QUE DES PIÈCES RECOMMANDÉES PAR LE FABRICANT.

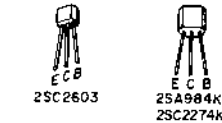

B (POWER SUPPLY) LINE
 DC VOLTAGE INDICATES AT STOP MODE

NOTE
 UNLESS OTHERWISE SPECIFIED
 ALL RESISTORS IN OHMS 1/4W (J)
 ALL CAPACITORS IN μ F 50 WV (J)
 (FS) = FAIL SAFE RESISTORS

GX-R99 MECHA
 SCHEMATIC DIAGRAM
 NO.11-8 831203A

GX-R99

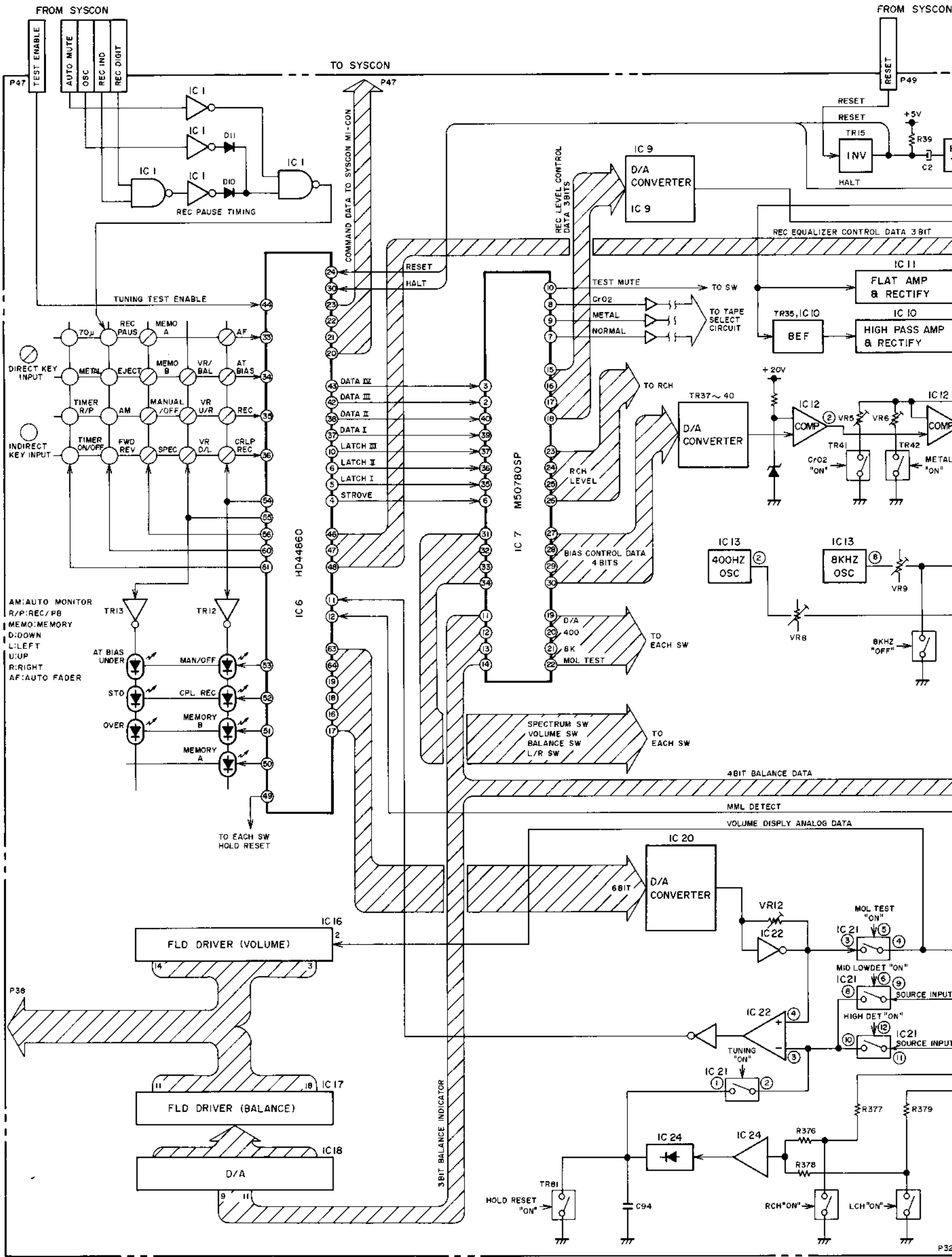

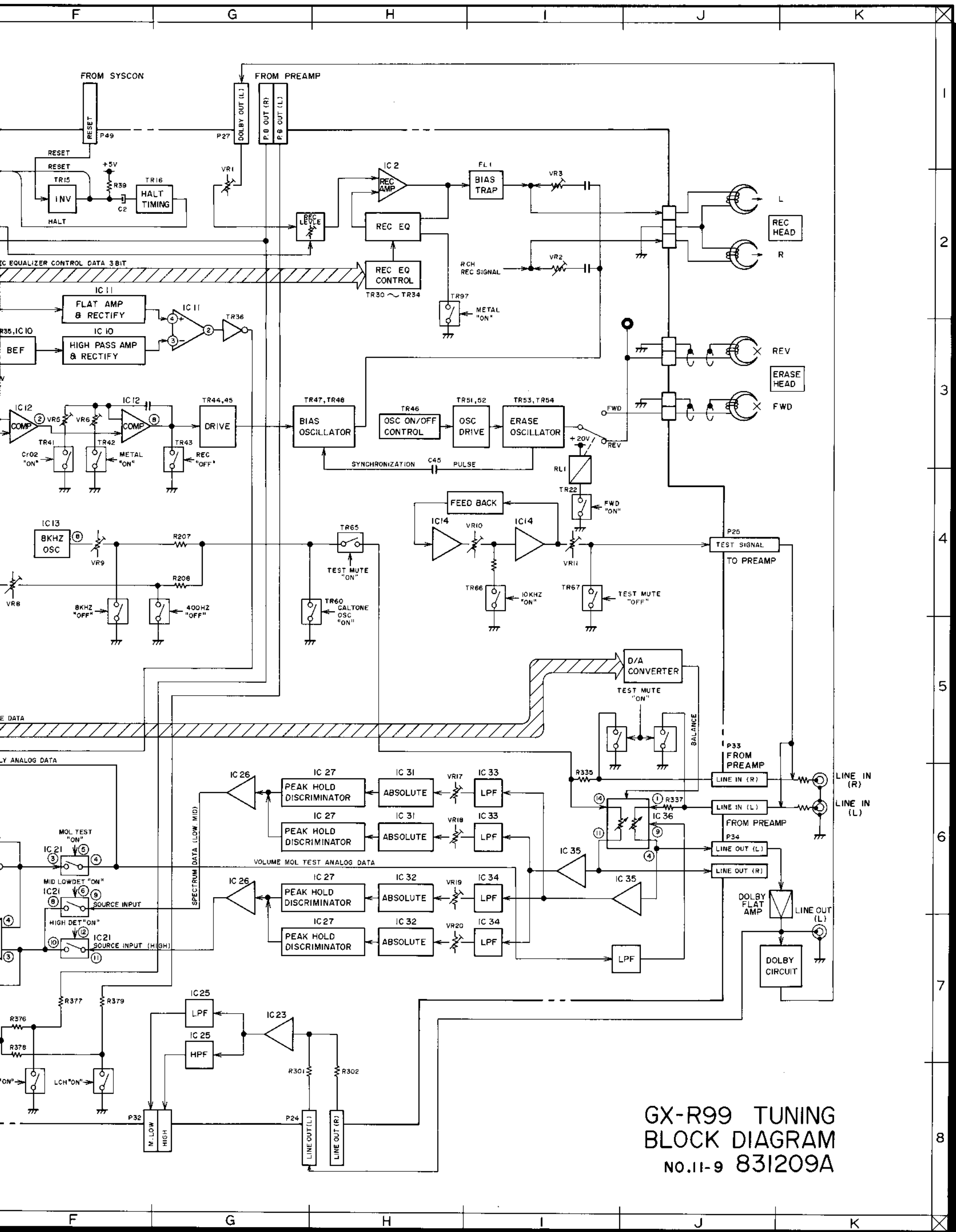

GX-R99 TUNING
BLOCK DIAGRAM
No.11-9 831209A

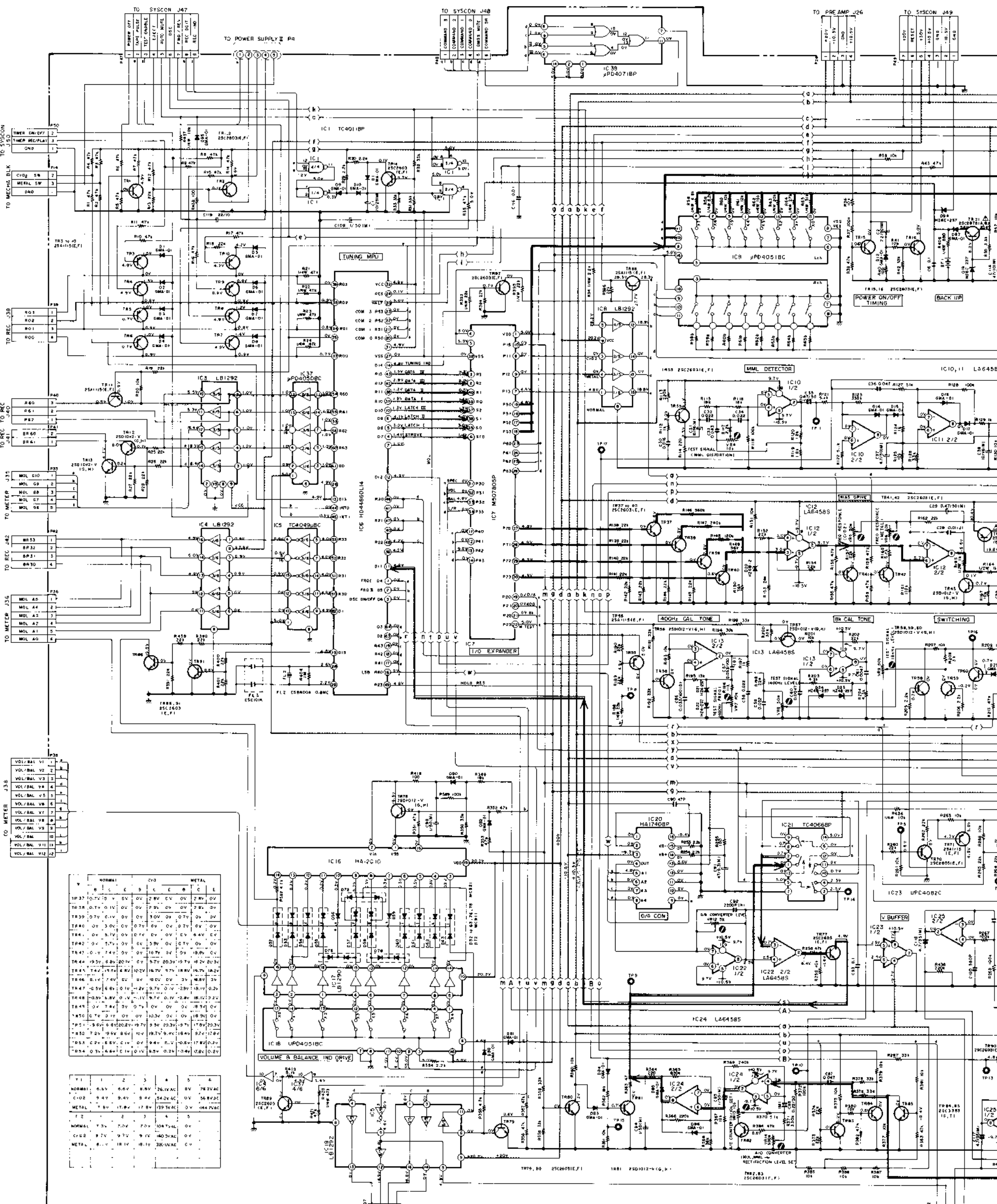

V	NORMAL				C102				METAL			
	A	B	C	D	A	B	C	D	A	B	C	D
TR37	10.7V	0.1V	0V	0V	2.8V	0V	0V	7.8V	0V	0V	0V	0V
TR38	0.7V	0.1V	0V	0V	7.8V	0V	0V	0V	0V	0V	0V	0V
TR39	0.7V	0.1V	0V	0V	10V	0V	0V	0V	0V	0V	0V	0V
TR40	0V	3.0V	0V	0V	0V	0V	0V	0V	0V	0V	0V	0V
TR41	0V	3.0V	0V	0V	0V	0V	0V	0V	0V	0V	0V	0V
TR42	0V	3.0V	0V	0V	5.8V	0V	0V	0V	0V	0V	0V	0V
TR43	1.5V	6.8V	20V	0V	18.7V	10.7V	18.7V	18.7V	18.7V	18.7V	18.7V	18.7V
TR44	1.5V	6.8V	20V	0V	18.7V	10.7V	18.7V	18.7V	18.7V	18.7V	18.7V	18.7V
TR45	1.5V	6.8V	20V	0V	18.7V	10.7V	18.7V	18.7V	18.7V	18.7V	18.7V	18.7V
TR46	0.1V	7.8V	0V	0V	10V	0V	0V	0V	0V	0V	0V	0V
TR47	0.5V	6.8V	0V	0V	3.7V	0V	0V	0V	0V	0V	0V	0V
TR48	0.5V	6.8V	0V	0V	3.7V	0V	0V	0V	0V	0V	0V	0V
TR49	0.7V	3.0V	0V	0V	10V	0V	0V	0V	0V	0V	0V	0V
TR50	0.7V	3.0V	0V	0V	10V	0V	0V	0V	0V	0V	0V	0V
TR51	0.7V	3.0V	0V	0V	10V	0V	0V	0V	0V	0V	0V	0V
TR52	0.7V	3.0V	0V	0V	10V	0V	0V	0V	0V	0V	0V	0V
TR53	0.7V	3.0V	0V	0V	10V	0V	0V	0V	0V	0V	0V	0V
TR54	0.7V	3.0V	0V	0V	10V	0V	0V	0V	0V	0V	0V	0V
TR55	0.7V	3.0V	0V	0V	10V	0V	0V	0V	0V	0V	0V	0V
TR56	0.7V	3.0V	0V	0V	10V	0V	0V	0V	0V	0V	0V	0V
TR57	0.7V	3.0V	0V	0V	10V	0V	0V	0V	0V	0V	0V	0V
TR58	0.7V	3.0V	0V	0V	10V	0V	0V	0V	0V	0V	0V	0V
TR59	0.7V	3.0V	0V	0V	10V	0V	0V	0V	0V	0V	0V	0V
TR60	0.7V	3.0V	0V	0V	10V	0V	0V	0V	0V	0V	0V	0V

V	1	2	3	4	5	6
NORMAL	0.5V	0.5V	0.5V	0.5V	0.5V	0.5V
C102	9.4V	9.4V	9.4V	9.4V	9.4V	9.4V
METAL	7.8V	7.8V	7.8V	7.8V	7.8V	7.8V

V	1	2	3	4	5	6
NORMAL	7.3V	7.0V	7.0V	10.4V	0V	0V
C102	9.7V	9.7V	9.7V	14.0V	0V	0V
METAL	8.4V	8.1V	8.1V	10.4V	0V	0V

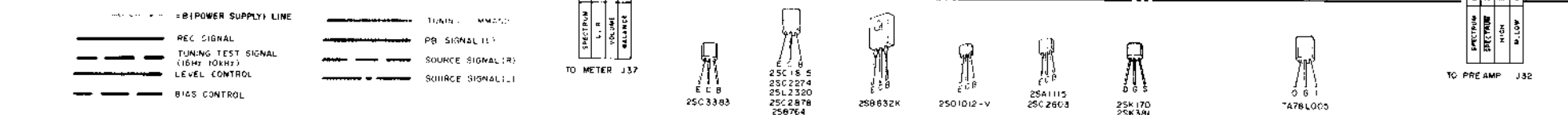

TO METER J37, TO METER J38, TO METER J39, TO PREAMP J32

001455

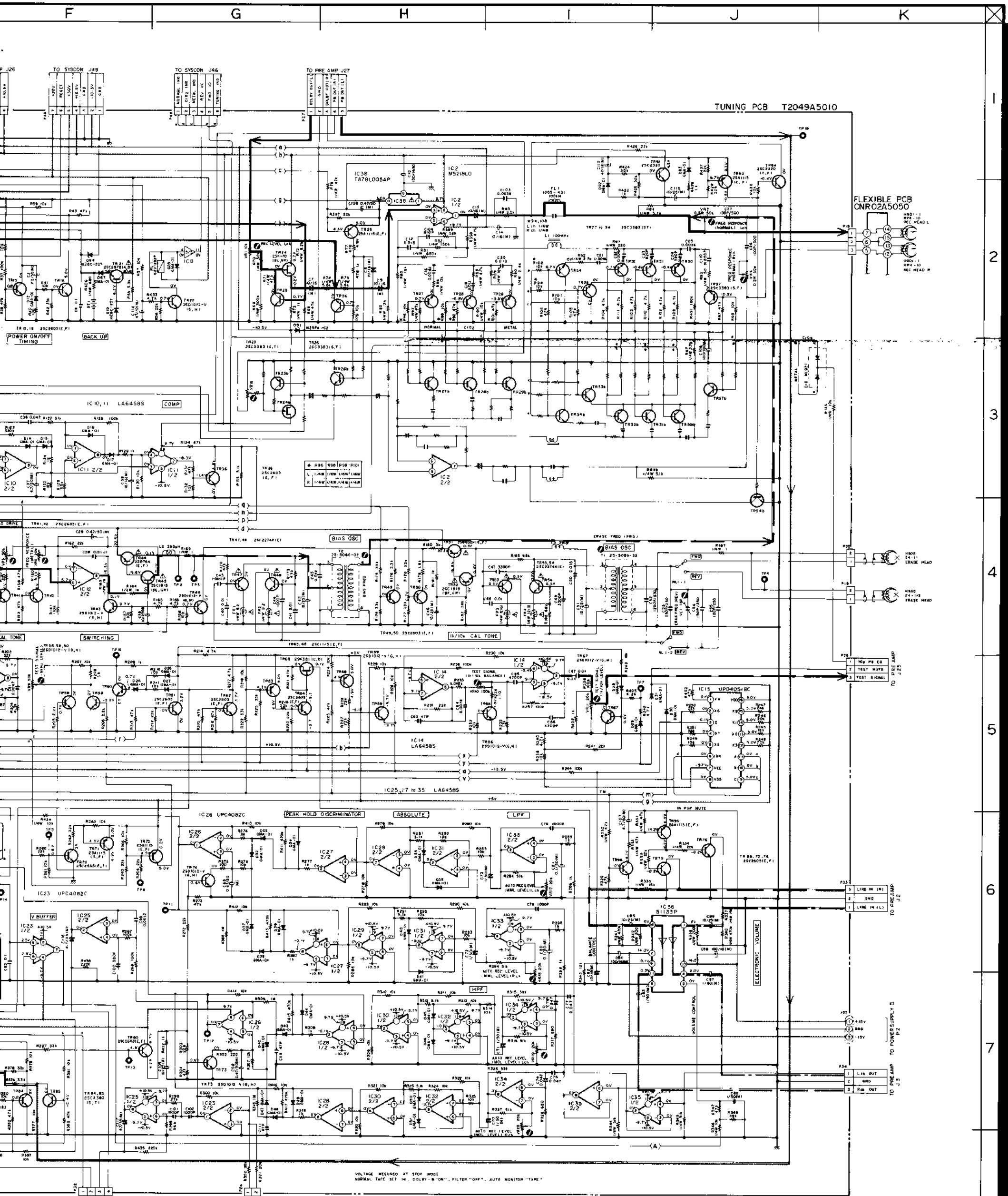

VOLTAGE MEASURED AT STOP MODE
NORMAL TAPE SET IN, DOLBY "ON", FILTER "OFF", AUTO MONITOR "TAPE"

WARNING: INDICATES SAFETY CRITICAL COMPONENTS FOR CONTINUED SAFETY.
REPAIRS TO SAFETY CRITICAL COMPONENTS MUST BE MADE ONLY WITH MANUFACTURER'S
RECOMMENDED PARTS.

ACCEPT ÉQUIVALENTS À L'INDICATEUR DES COMPOSANTS CRITIQUES DE SÉCURITÉ
POUR MANUTENIR LE NIVEAU DE SÉCURITÉ DE L'APPAREIL
NE REMPLACEZ QUE DES PIÈCES RECOMMANDÉES PAR LE FABRICANT

NOTE
UNLESS OTHERWISE SPECIFIED
ALL RESISTORS IN OHMS (1/6W/1%)
ALL CAPACITORS IN µF (50V/1%)

GX-R99 TUNING
SCHEMATIC DIAGRAM
No. 11-10 831210A

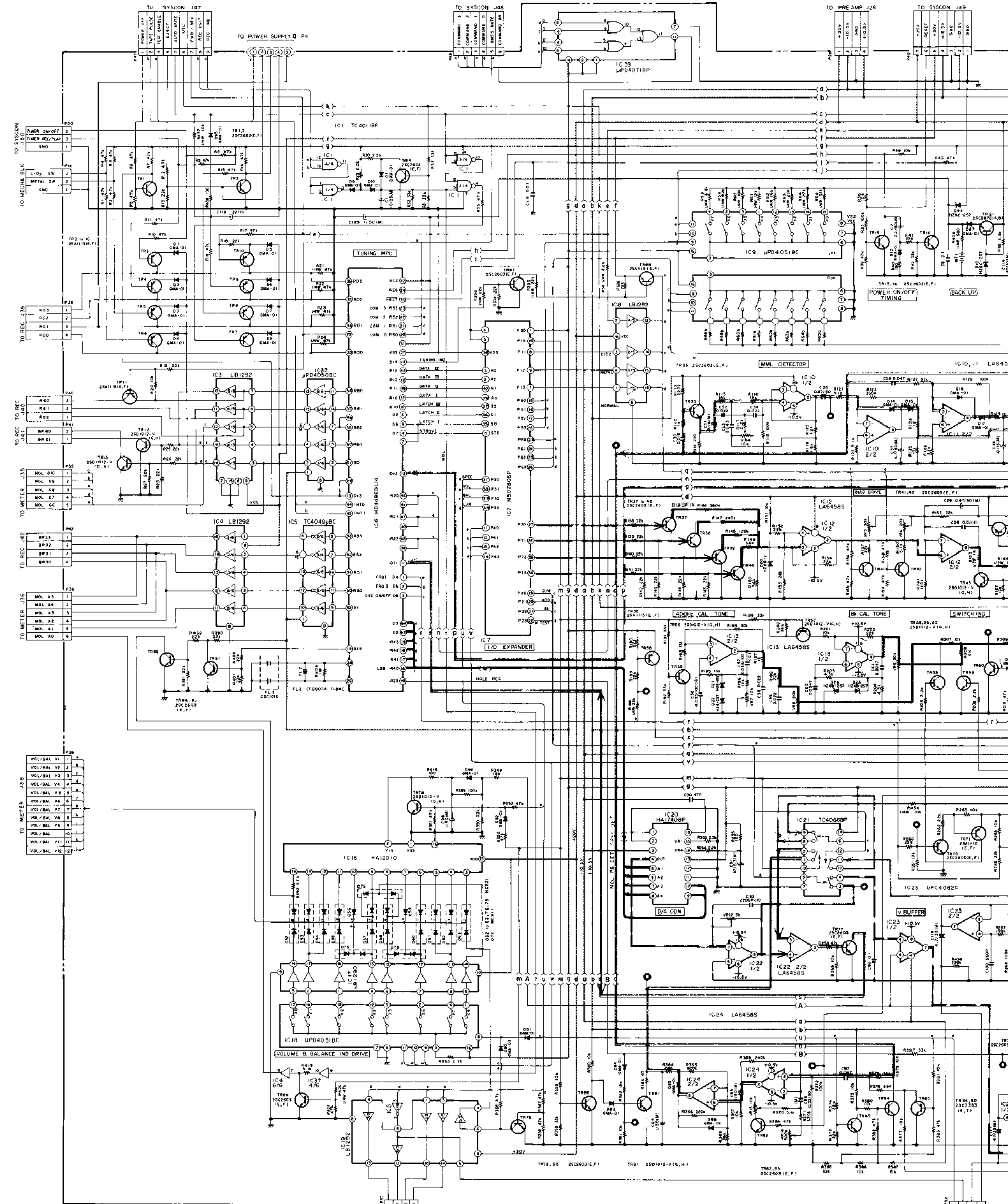

- - - - - POWER SUPPLY LINE
 - - - - - AC/BR SIGNAL
 - - - - - BIAS CONTROL
 - - - - - DIGITAL DATA FOR D/A
 - - - - - ANALOG SIGNAL FOR VOL CONT
 - - - - - SPEAKER SIGNAL
 - - - - - SPECTRUM METER
 - - - - - HP 100 M.V.
 - - - - - PE 400 MM.

- 25C3383
- 25C1915
- 25C2274
- 25L2320
- 25C2778
- 25R784
- 25B632K
- 25D1012-V
- 25A1115
- 25C2603
- 25K170
- 25K381
- TA79L005

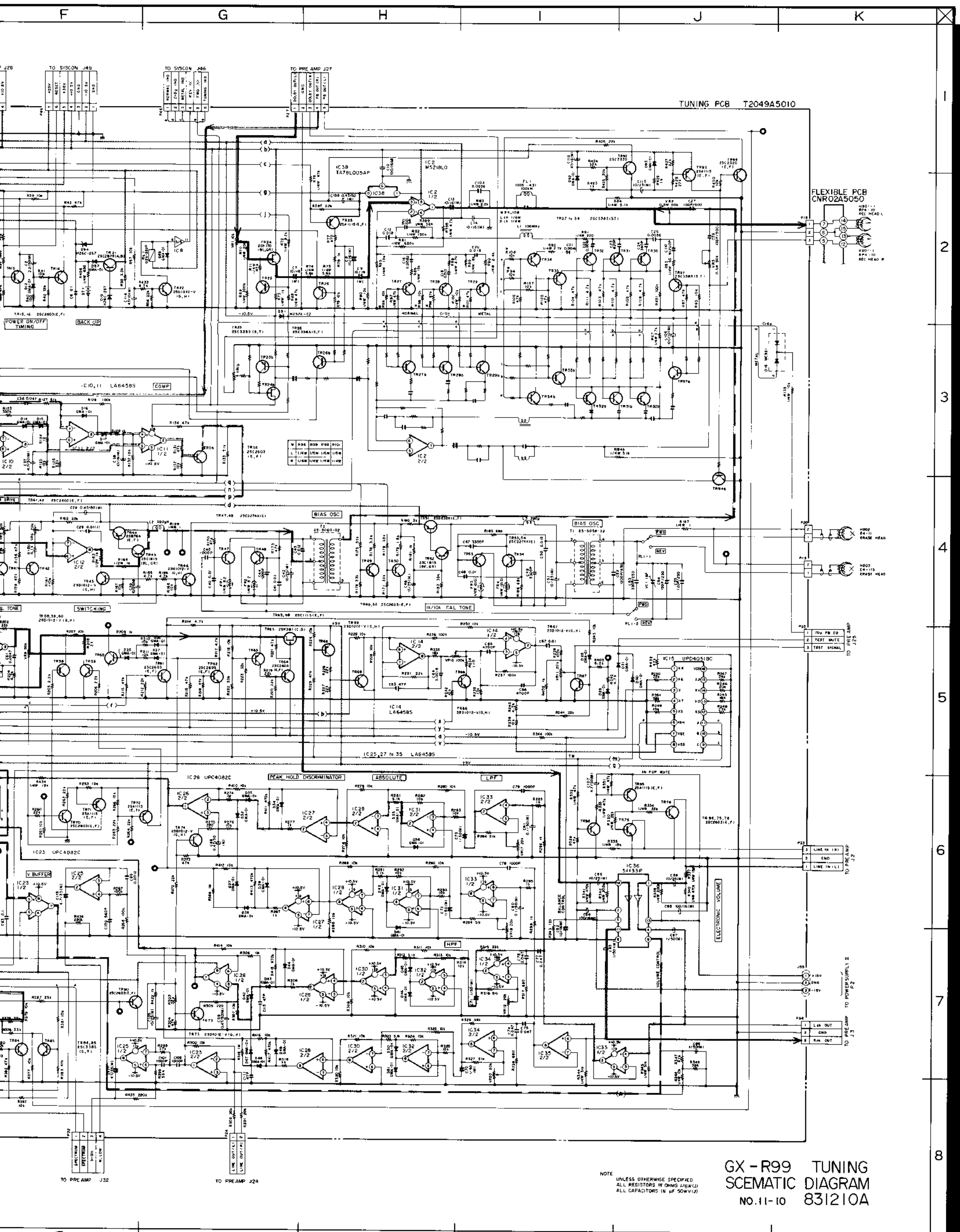

TUNING PCB T2049A5010

FLEXIBLE PCB
CNR02A5050

GX-R99 TUNING
SCHEMATIC DIAGRAM
NO.11-10 831210A

NOTE:
UNLESS OTHERWISE SPECIFIED
ALL RESISTORS IN OHMS 1/8W(1/2)
ALL CAPACITORS IN pF 50WV(1/2)

1
2
3
4
5
6
7
8

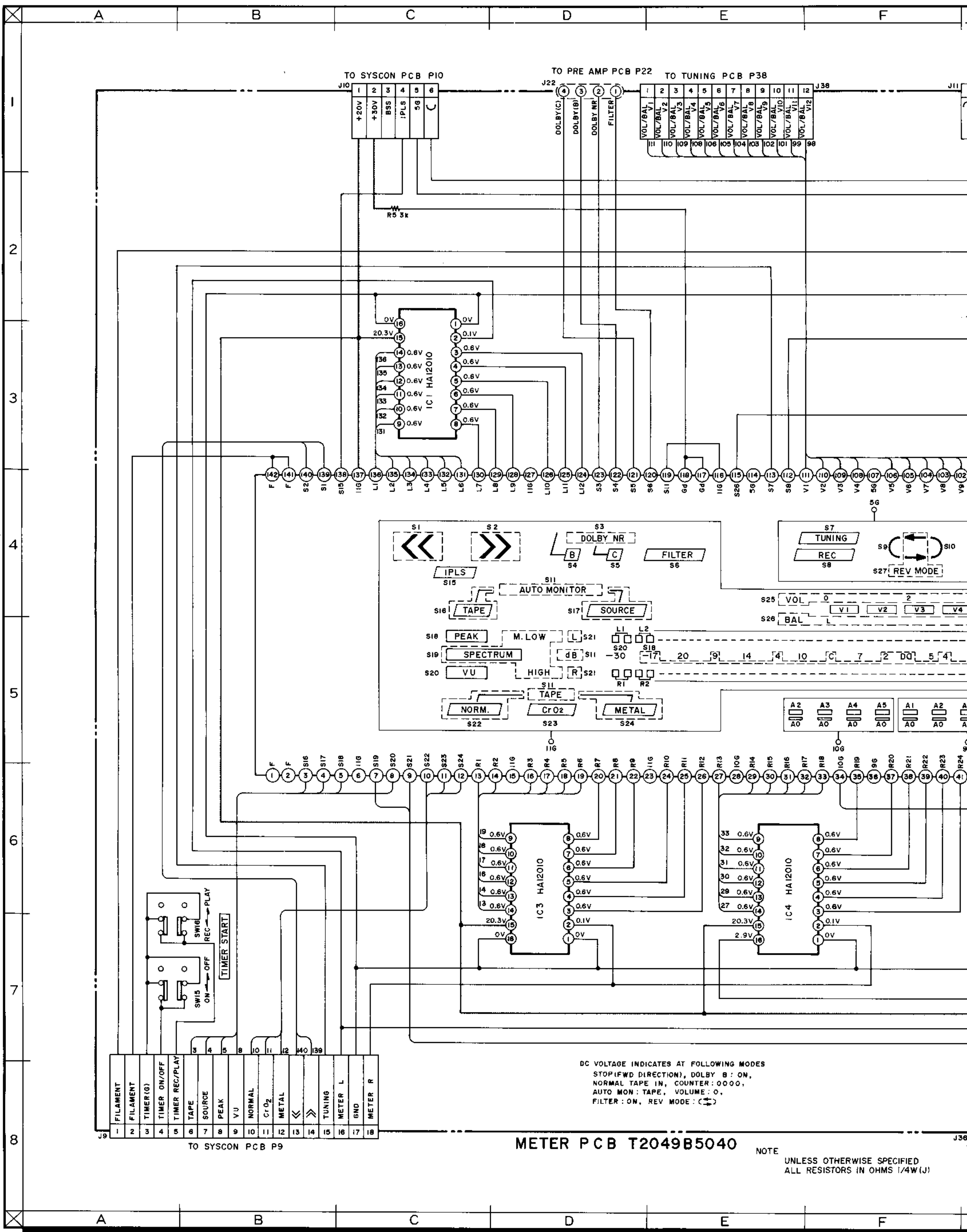

DC VOLTAGE INDICATES AT FOLLOWING MODES
 STOP (FWD DIRECTION), DOLBY B : ON,
 NORMAL TAPE IN, COUNTER : 0000,
 AUTO MON : TAPE, VOLUME : 0,
 FILTER : ON, REV MODE : (↔)

METER PCB T2049B5040

NOTE
 UNLESS OTHERWISE SPECIFIED
 ALL RESISTORS IN OHMS 1/4W(J)

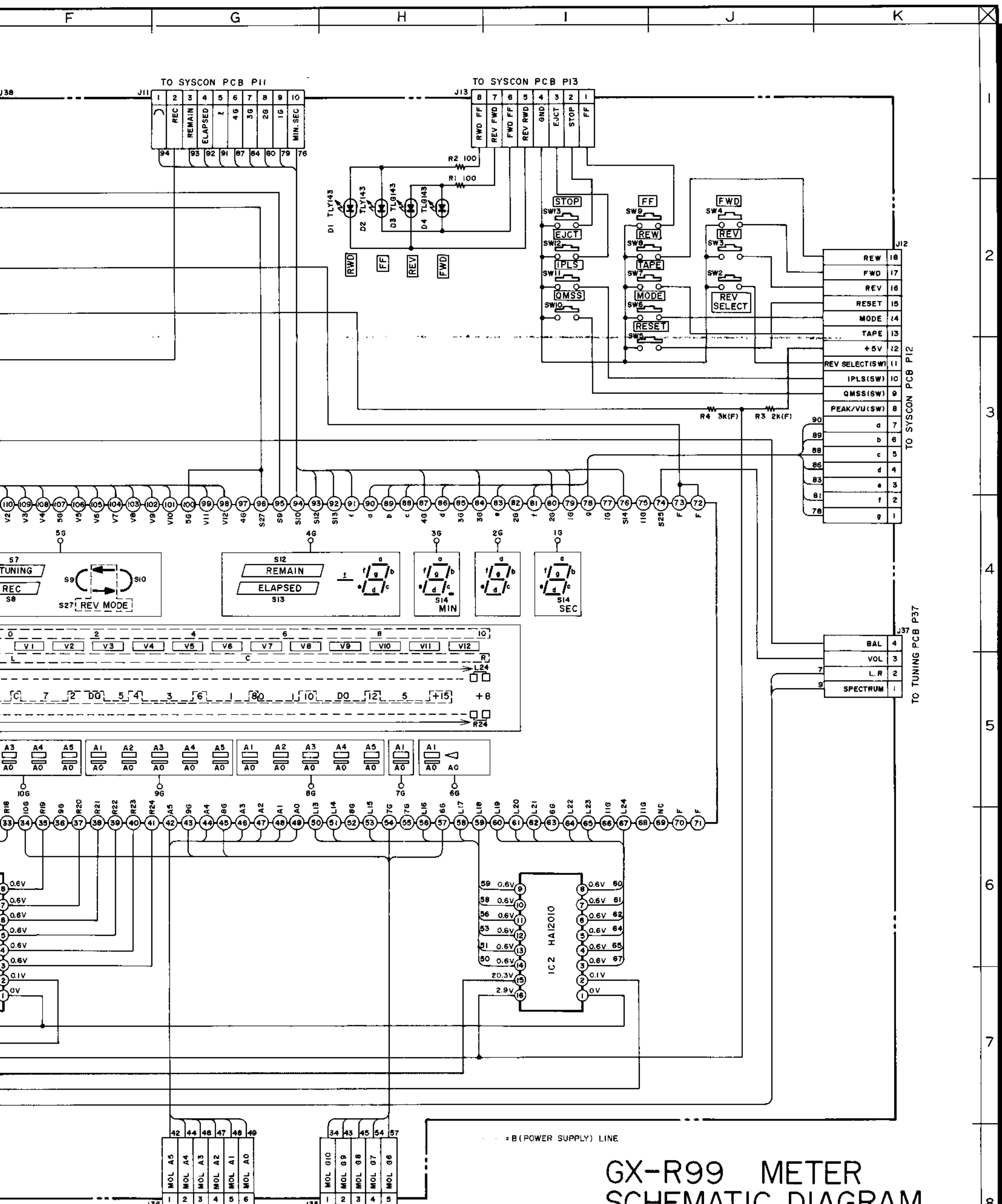

GX-R99 METER
 SCHEMATIC DIAGRAM
 NO.11-11 831211A
 2c

RESISTORS UNLESS OTHERWISE SPECIFIED
 ARE 1/4W (1/2)

TUNING OUTPUT TIMING CHART 1
AUTO TUNING

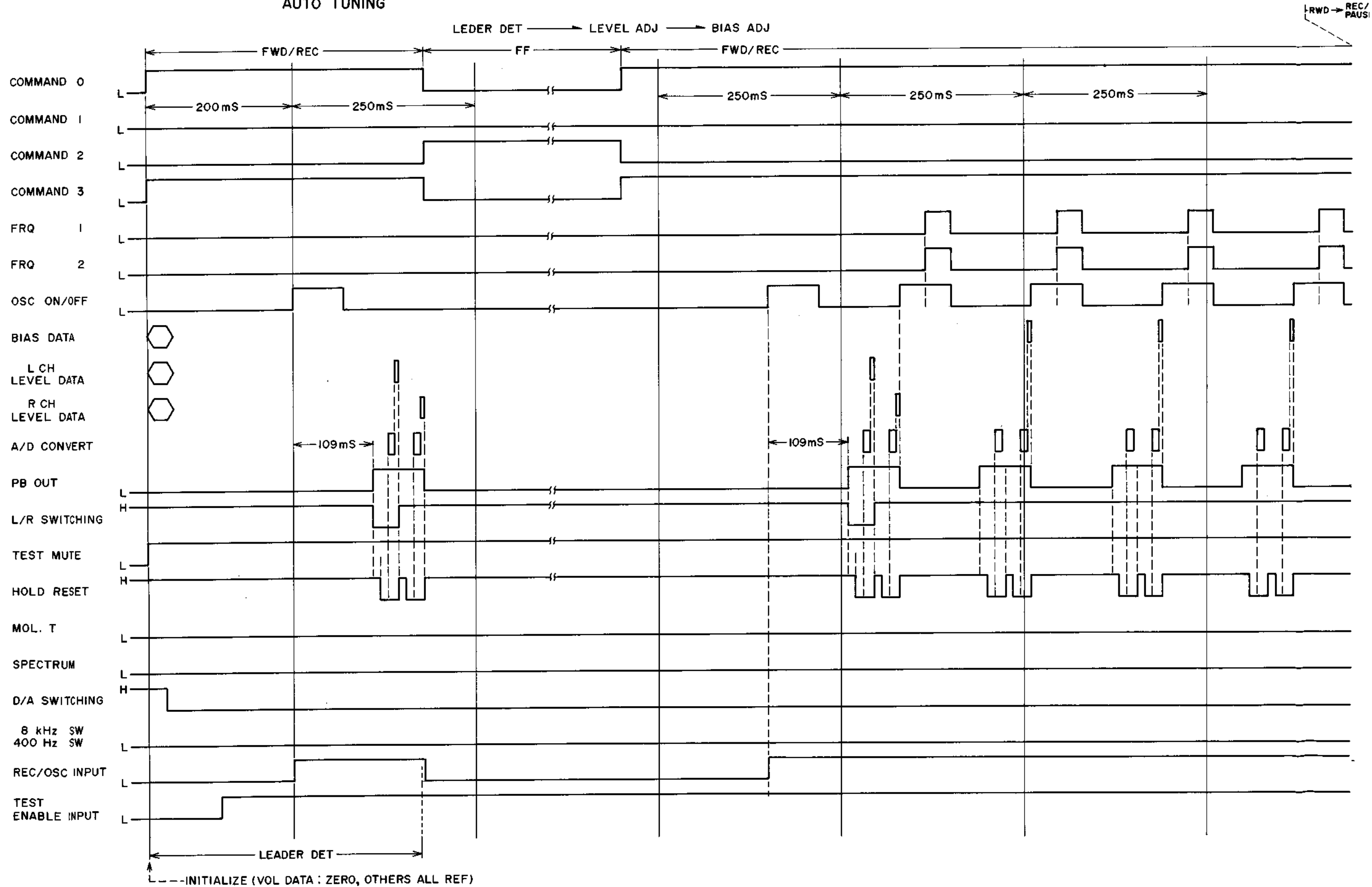

TUNING OUTPUT TIMING CHART 2
FULL AUTO SYSTEM

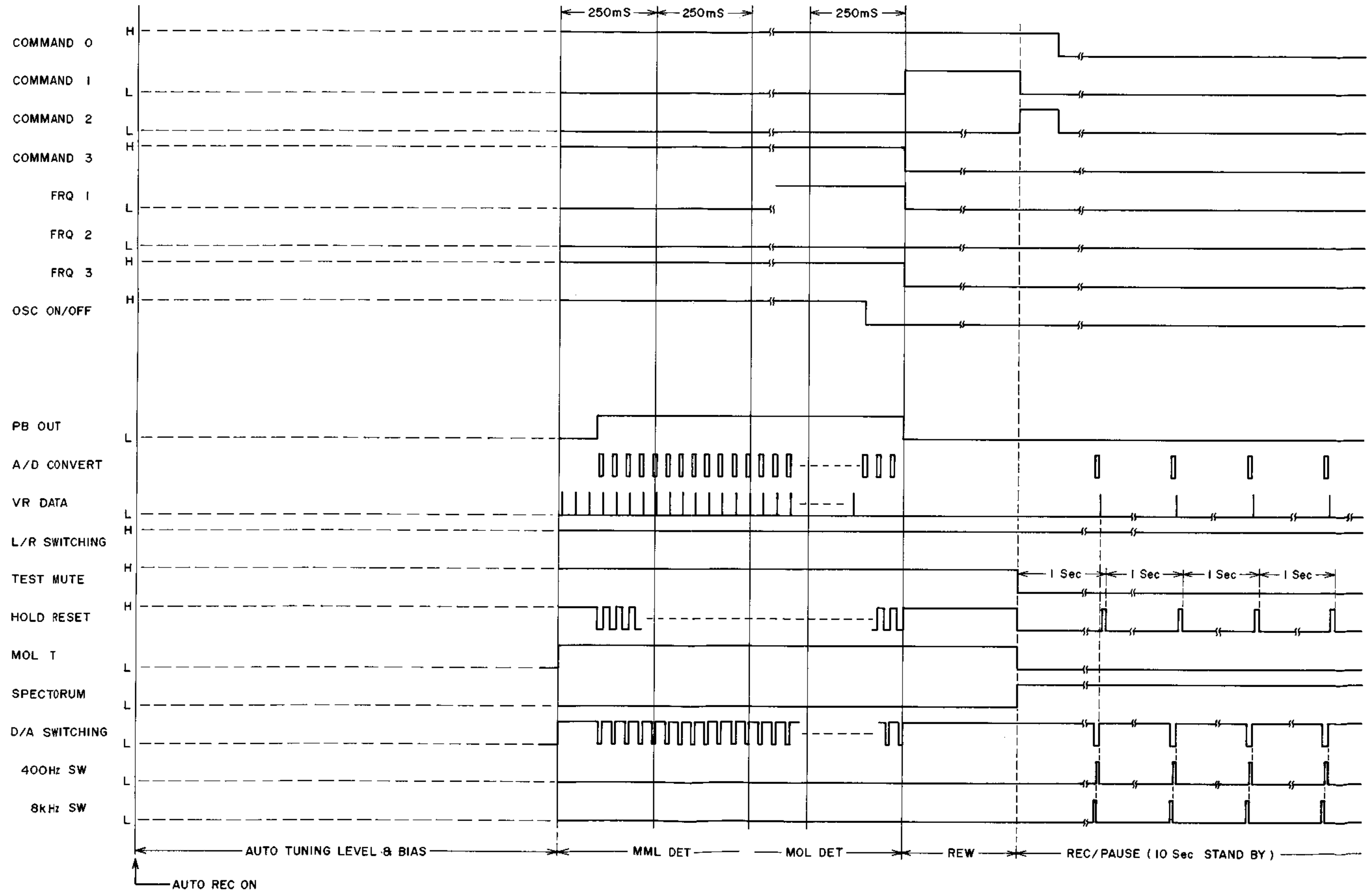

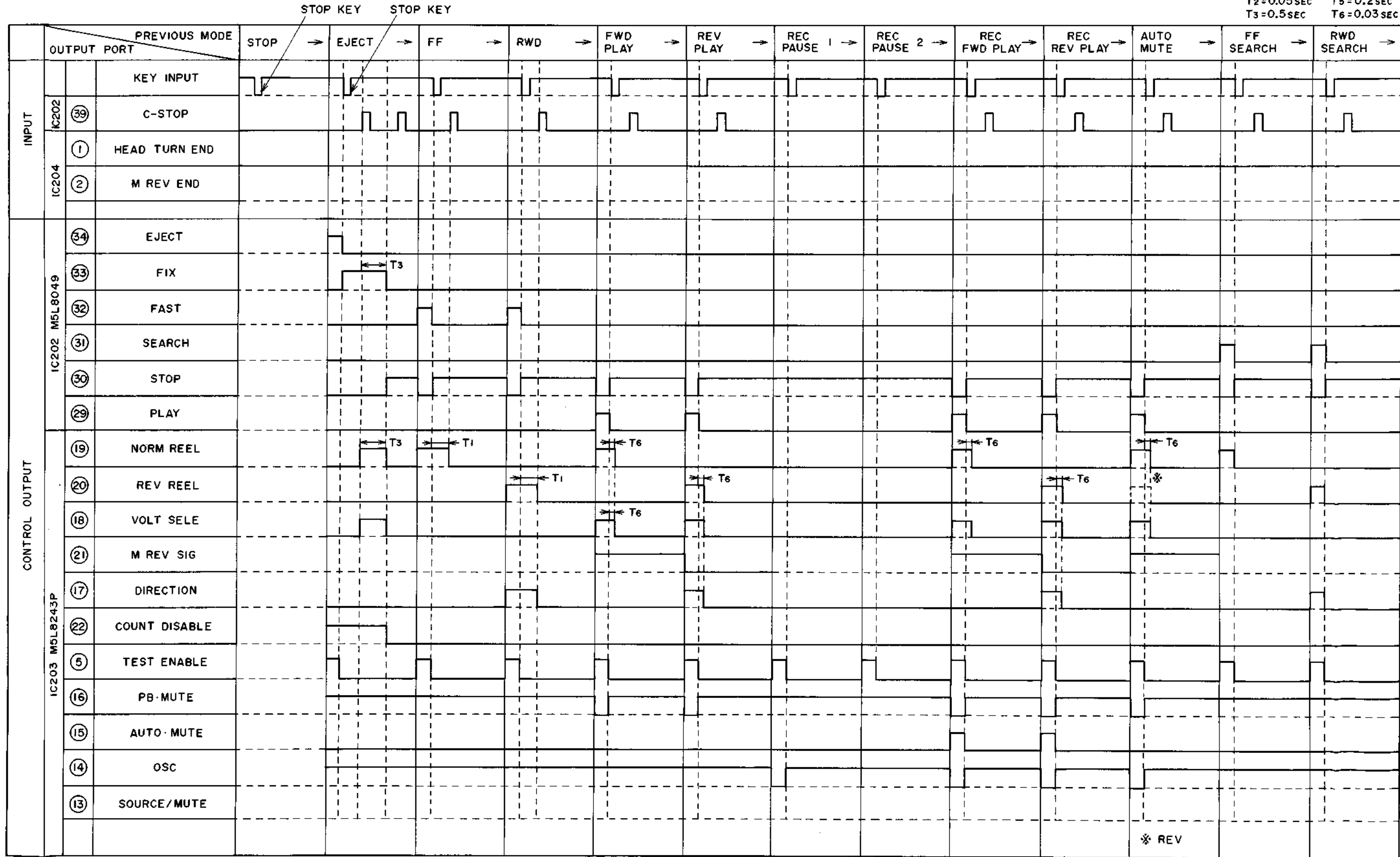

* REV

STOP

○○○ → EJECT

T₆ = 0.03sec

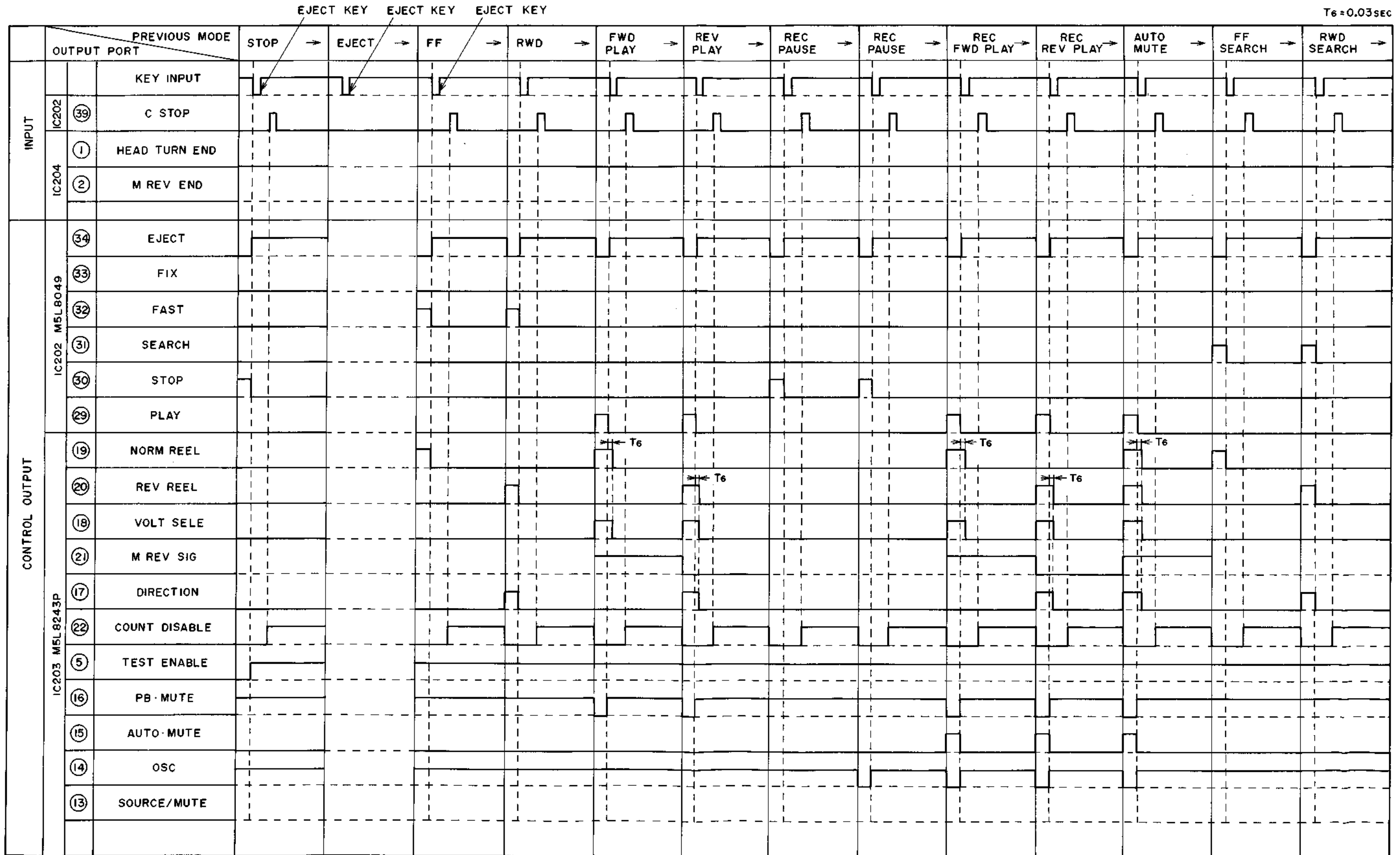

EJECT