

AKAI SERVICE MANUAL

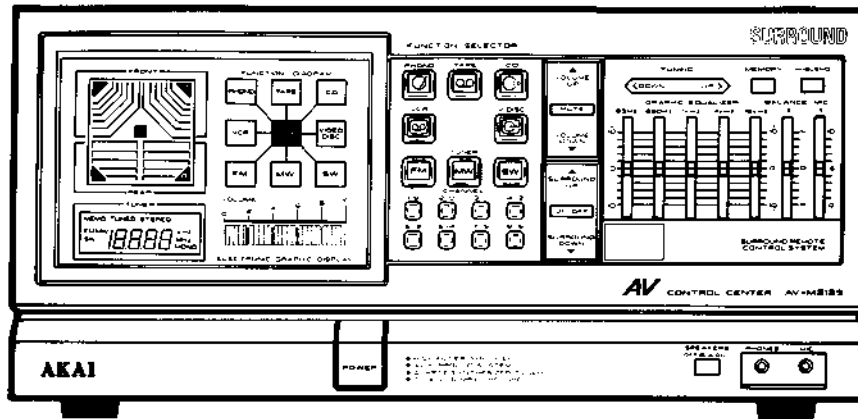

AV CONTROL CENTER

MODEL AV-M313L/S

SPECIFICATIONS

Amplifier section		AM		
Power output	40 W + 40 W (0.2% T.H.D. 8 ohms)	MW	LW	SW
DIN	46 W + 46 W	Frequency Range	531 kHz to 144 kHz to 4.6 MHz to	1602 kHz (9k) 351 kHz 9.8 MHz
French Norm	45 W + 45 W		530 kHz to	
Frequency Response	5 Hz to 80 kHz \pm 3dB		1600 kHz (10k)	
Equalizer	\pm 8 dB (63 Hz, 250 Hz, 1 kHz, 4 kHz, 16kHz)	Usable Sensitivity	300 μ V/m	1000 μ V/m 300 μ V/m
Input Impedance	47 kohms	Selectivity	20 dB	25 dB 35 dB
	(Phono/Aux/Tape /VCR/V. Disc/Mic)	Image Rejection Ratio	45 dB	35 dB 25 dB
Input Sensitivity	150 mV	IF Rejection Ratio	35 dB	35 dB 30 dB
	(Phono/Aux/Tape/VCR/V. Disc)	S/N Ratio	35 dB	35 dB 35 dB
	0.7 mV Mic	Power Requirements	120V, 60 Hz for USA & Canada	
S/N Ratio (HF-A)			220V, 50 Hz for Europe, except UK	
Phono/Aux/Tape/			240V, 50 Hz for UK & Australia	
VCR/V. Disc	80 dB		110V/120V/240V, 50 Hz/60 Hz convertible	
Mic	63 dB		for other countries	
Speaker	8 to 16 ohms Surround and Main	Dimensions	350 (W) \times 160 (H) \times 325 (D) mm	
			13.7 (W) \times 6.3 (H) \times 12.8 inches	
Tuner section		Weight	7.3 kg (16.1 lbs)	
FM		RC-M313 Remote Control		
Frequency Range	87.5 to 108 MHz	System	Infrared PCM	
Usable Sensitivity	12.7 dBf (1.2mV/75 ohms)	Carrying Frequency	38 kHz \pm 0.2 kHz	
S/N ratio Mono/Stereo	65 dB Mono/60 dB Stereo	Max. Operation distance ..	up to 8m	
Selectivity	60 dB	Directivity	\pm 30	
Image Rejection Ratio	50 dB	Batteries	21.5 V (R6, AA, UM-3)	
IF Rejection Ratio	80 dB			
Capture Ratio	2.0 dB			
Stereo Separation	40 dB			

* For improvement purposes, specifications and design are subject to change without notice.

★SAFETY INSTRUCTIONS

PRECAUTIONS DURING SERVICING

- Parts identified by the Δ symbol parts are critical for safety. Replace only with parts number specified.
- In addition to safety, other parts and assemblies are specified for conformance with such regulations as those applying to spurious radiation. These must also be replaced only with specified replacements.
Examples: RF converters, tuner units, antenna selector switches, RF cables, noise blocking capacitors, noise blocking filters, etc.
- Use specified internal wiring. Note especially:
 - Wires covered with PVC tubing
 - Double insulated wires
 - High voltage leads
- Use specified insulating materials for hazardous live parts. Note especially:
 - Insulation Tape
 - PVC tubing
 - Spacers (Insulating Barriers)
 - Insulation sheets for transistors
 - Plastic screws for fixing microswitch (especially in turntable)
- When replacing AC primary side components (transformers, power cords, noise blocking capacitors, etc.), wrap ends of wires securely about the terminals before soldering.

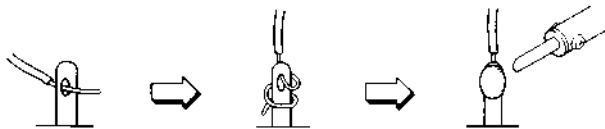

- Observe that wires do not contact heat producing parts (heatsinks, oxide metal film resistors, fusible resistors, etc.).

- Check that replaced wires do not contact sharp edged or pointed parts.
- Also check areas surrounding repaired locations.
- Use care that foreign objects (screws, solder droplets, etc.) do not remain inside the set.

SAFETY CHECK AFTER SERVICING

Confirm the specified insulation resistance between power cord plug prongs and externally exposed parts of the set is greater than 10 M ohms, but for equipment with external antenna terminals (tuner, receiver, etc.) and is intended for [C] or [A], specified insulation resistance should be headphone jacks line-in-out jacks etc. more than 2.2 M ohms (ground terminals, microphone jacks).

PRECAUTION FOR THE LITHIUM BATTERY

The LITHIUM BATTERY employed for memory Back up has a explosive probability when the BATTERY itself is excessive heated.

IN CASE OF REPLACING: RESOLDER and SOLDER AS RECOMMENDED WAY.



[DANGER]



[RECOMMENDED WAY]

★INFORMATION

SYMBOLS FOR PRIMARY DESTINATION

Alphabet indicates the destination of the units as listed below.

Symbols	Principal Destinations
[A]	USA
[B]	UK
[C]	Canada
[E]	Europe (except UK)
[J]	Japan
[S]	Australia
[V]	W. Germany only
[U]	Universal Area
[Y*]	Custom version

VOLTAGE CONVERSION ([U] Model only)

Before connecting the power cord. SET the VOLTAGE SELECTOR located on the rear panel with a screwdriver so that the correct voltage is indicated.

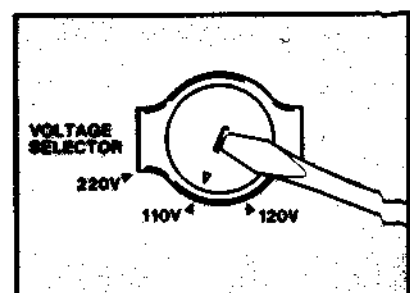

FUNCTION SELECTORS

Use these selectors to choose the audio or video source for playback and recording purposes.

Sélecteurs de fonction (FUNCTION)

Utilisez ces sélecteurs pour choisir la source audio ou vidéo à des fins de reproduction et d'enregistrement.

FUNCTION DIAGRAM**Diagramme de fonction (FUNCTION)****Surround Display FRONT/REAR**

Normally shows front speaker effects (F). When the surround switch is ON the display also shows the surround speaker effects (R).

Affichage d'ambiance FRONTAL/ARRIERE (FRONT/REAR)

Indique normalement les effets du haut-parleur d'ambiance frontal (F). Lorsque le commutateur d'ambiance (SURROUND) est réglé sur la position sous tension (ON), l'affichage indique aussi les effets du haut-parleur d'ambiance arrière (R).

TUNER Display

L.C. display which shows the Band, Frequency, STEREO, MONO, and MEMO.

Affichage du tuner (TUNER)

Affichage à cristaux liquides L.C. indiquant la gamme, la fréquence, STEREO, MONO et la mémorisation (MEMO).

VOLUME electronic graphic display

Displays the volume level according to the VOLUME control (UP/▲/DOWN/▼) adjustment.

Affichage graphique électronique du VOLUME

Cet affichage indique le niveau du volume en accord avec les réglages de la commande du VOLUME Augmentation (UP) (▲) / Diminution (DOWN) (▼).

CHANNEL (1-8/9-16) Buttons

Use these buttons to memorize and recall preset stations.

Touches de canal (1-8/9-16) (CHANNEL)

Utilisez ces touches pour mémoriser et rappeler des stations pré-réglées.

SURROUND UP(▲)/DOWN(▼), ON/OFF Control

Use this control to switch ON and OFF, and to control the level of the surround speakers. Note: When the surround system is not in use, keep this control set to the OFF position.

Commande de mise sous tension/hors circuit (ON/OFF)/Augmentation (UP) (▲)/Diminution (DOWN) (▼) d'ambiance (SURROUND)

Utilisez cette commande pour mettre sous tension (ON) et hors circuit (OFF) le système d'ambiance au signal pour commander le niveau des haut-parleurs d'ambiance.

Remarque:

Lorsque le système d'ambiance n'est pas utilisé, réglez cette commande sur la position hors circuit (OFF).

Remote control receiver window

Receives the remote control infrared signals.

Fenêtre de réception de la télécommande

Reçoit les signaux infrarouges de la télécommande.

VOLUME UP(▲)/DOWN(▼), MUTE ON/OFF Control

To adjust the volume level and turning on and off audio mute.

Commande de VOLUME Augmentation (UP) (▲) / Diminution (DOWN) (▼), de sourdine (MUTE) sous tension/hors circuit (ON/OFF)

Pour régler le niveau du volume et pour mettre sous tension (ON) et hors circuit (OFF) la sourdine audio.

TUNING UP(▲) DOWN(▼) Control

Use it to tune in radio frequencies.

Commande de syntonisation (TUNING) Vers le haut (UP) (▲), Vers le bas (DOWN) (▼)

Utilisez cette commande pour syntoniser des fréquences radio.

MEMORY button

Use it when memorizing radio stations with the preset station buttons.

Touche de mémoire (MEMORY)

Utilisez cette commande lorsque vous mémorisez des stations radio avec les touches de station pré-réglée.

MONO switch

Use this switch for Monaural reception of FM Stereo stations.

Commutateur MONO

Utilisez ce commutateur pour réception monaural des stations stéréo FM.

MIC mixing control

Use to vary the microphone volume when mixing.

Commande de mixage du microphone (MIC)

Cette commande est utilisée pour varier le volume du microphone lors de mixage.

BALANCE Control

To adjust the left and right channel balance.

Commande d'équilibre (BALANCE)

Pour régler l'équilibre des canaux gauche et droit.

PHONES jack

For connection of headphones.

Jack de casque (PHONES)

Pour connecter un casque.

MIC jack

For microphone connection.

Jack de microphone (MIC)

Pour connecter un microphone.

SPEAKERS ON(▲)/OFF(■) switch

To turn the speaker systems ON and OFF.

Commutateur de mise sous tension (ON) (▲) / hors circuit (OFF) (■) des haut-parleurs (SPEAKERS)

Pour mettre sous tension (ON) et hors circuit (OFF) le système d'enceintes.

GRAPHIC EQUALIZER frequency controls

To finely adjust the frequency levels between a range of 63Hz to 16kHz, during playback and recording operations.

Commandes de fréquence de l'égaliseur graphique (GRAPHIC EQUALIZER)

Pour régler finement les niveaux de fréquence dans une bande de gamme située entre 63 Hz et 16 kHz lors d'opérations de reproduction et d'enregistrement.

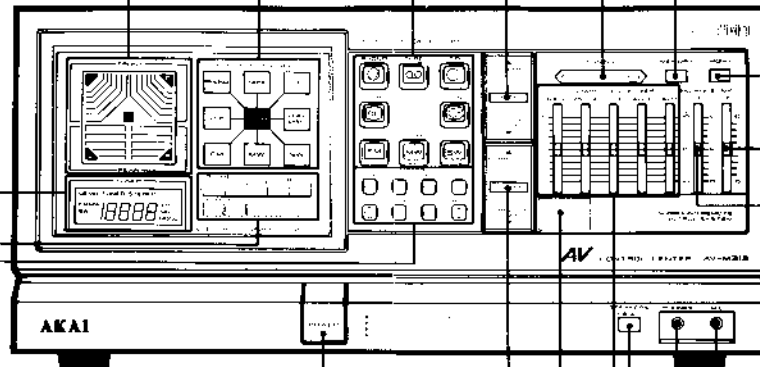

III. PRINCIPAL PARTS LOCATION

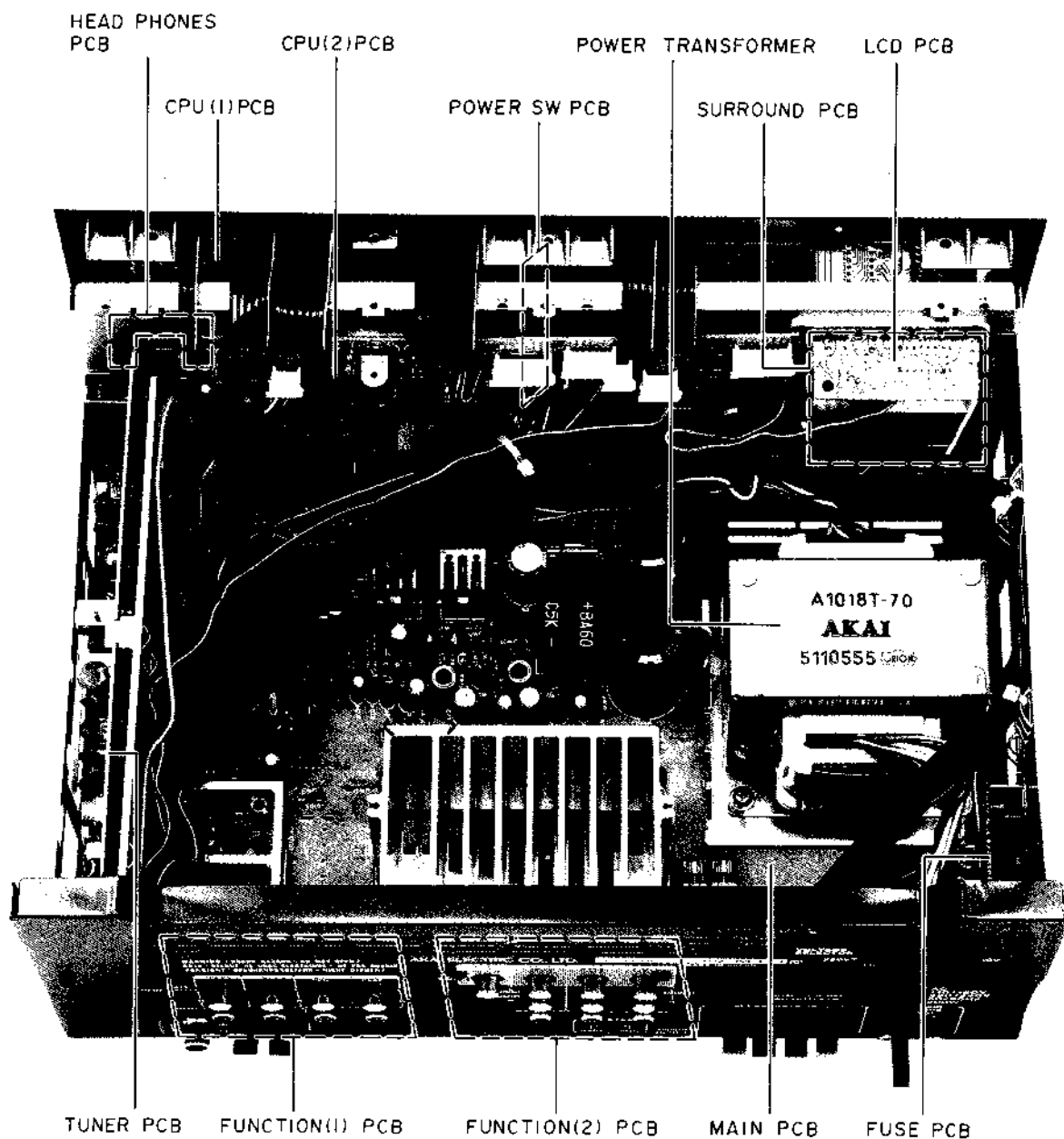

Fig. 3-1 Top View

IV. ELECTRICAL ADJUSTMENT

4-1. INSTRUMENT CONNECTIONS AND ADJUSTMENT POINTS FOR TUNER ADJUSTMENT

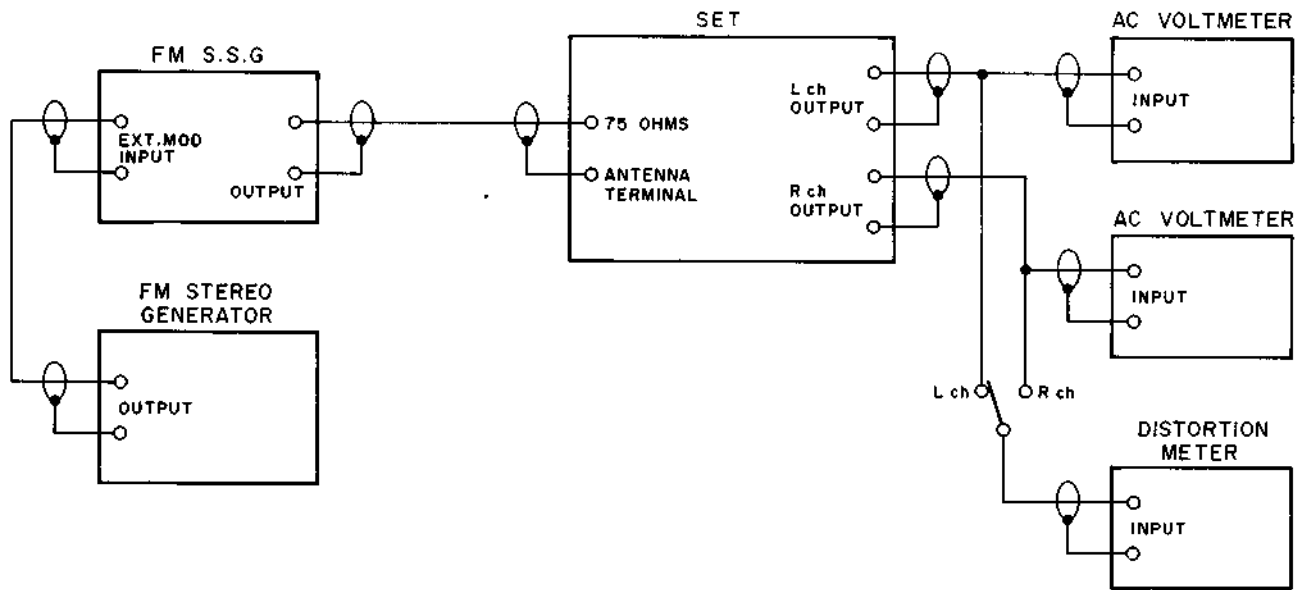

Fig. 4-1. Instrument Connections for FM Section Adjustment

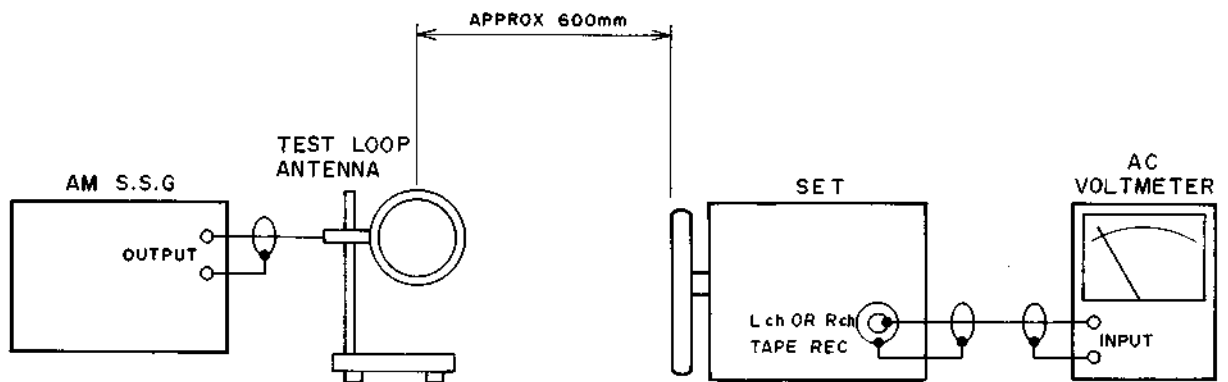

Fig. 4-2. Instrument Connections for AM (MW, LW, SW) Section Adjustment

4-2. MODEL AV-M313L TUNER ADJUSTMENT

STEP	ADJUSTMENT ITEM
1.	SSG FREQ. & ATT.
2.	SET TUNING FREQ.
3.	TEST POINT & ADJ. PART
4.	RESULT & REMARKS

Test point
Adj. Part

NOTES:

1. Set the SSG to 75 kHz deviation, 1 kHz for C, A, U, S models; 40 kHz deviation, 1 kHz for B, E, V models.
2. Readjust step 2 to step 6, in case T1 is turned more than a quarter turn obtaining the proper distortion (STEREO).
3. Confirm that the sensitivity margin between Low and High Range sensitivities is within 3 dB, otherwise readjust Low and High Range sensitivity.
4. In step 3, normally confirmation only, except waved coil by mistake.
5. 0 dBu = 1 μ V

FM

2	FM LOW RANGE SENSITIVITY
1.	88 MHz (Mono) 6 dBu
2.	88 MHz
3.	Line out. L1 to L5
4.	* Connect TP2 to GND. See Note 4. * Within 3% distortion factor.

3	FM HIGH RANGE SENSITIVITY
1.	108 MHz (Mono) 6 dBu
2.	108 MHz
3.	Line out. L1 to L5
4.	* Connect TP2 to GND. See Note 4. * Within 3% distortion factor.

1	FM OSC
1.	No signal input
2.	108 MHz
3.	Connect the DC Voltmeter between +BT and GND. L7
4.	$3.5 \pm 0.1V$

4	
	For best result, repeat steps 2 and 3 two or three times.

8	MPX FREE RUNNING FREQUENCY
3.	Connect a Frequency counter to TP1. VR1
4.	19 kHz \pm 50 Hz

6	DISTORTION FACTOR
1.	87.5 MHz (Mono) 60 dBu
2.	87.5 MHz
3.	Line out. T5
4.	Less than 0.3%

7	
	For best result, repeat steps 5 and 6 two or three times.

5	FM CENTER VOLTAGE
1.	No signal input
2.	Tunes only noise without interference from Broadcasting.
3.	Connect the DC Voltmeter between TP3 and TP4. T4
4.	0V

LW

NOTES:

1. Set the SSG to 30% 1 kHz of each.
2. Confirm that the sensitivity margin between Low and High Range sensitivities is within 6 dBu, otherwise readjust Low and High Range sensitivity.

4	
	For best result repeat steps 2 and 3 two or three times.

1	LW OSC
1.	No signal input
2.	315 kHz
3.	Connect the DC Voltmeter between TP5 and GND. T7
4.	$7.5 \pm 0.15V$

2	LW LOW RANGE SENSITIVITY
1.	106 kHz 70 dBu
2.	106 kHz
3.	Line out. T6
4.	Within 10% distortion factor.

3	LW HIGH RANGE SENSITIVITY
1.	300 kHz 70 dBu
2.	300 kHz
3.	Line out. VC2
4.	Within 10% distortion factor.

5	DISTORTION
1.	200 kHz 74 dBu
2.	200 kHz
3.	Line out. Confirmation
4.	Less than 3.5%

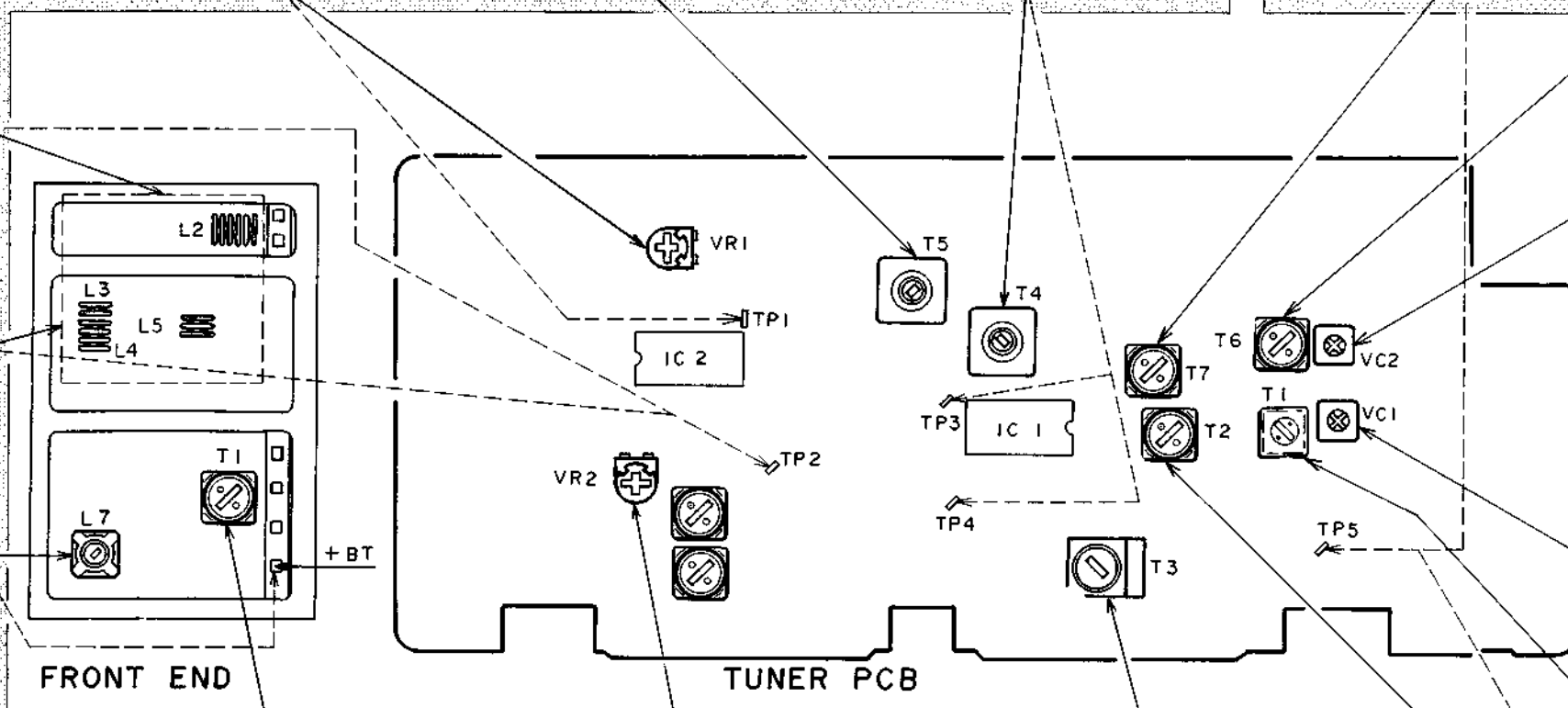

FRONT END

TUNER PCB

10	DISTORTION (STEREO)
1.	98 MHz Stereo L ch (R ch) 60 dBu
2.	98 MHz
3.	Line out. T1
4.	Less than 0.5% (Both channel)

9	STEREO SEPARATION
1.	98 MHz, stereo
2.	98 MHz
3.	Line out. VR2
4.	Minimum output of R ch (L ch)

MW

5	AM IF
1.	603 (600) kHz 74 dBu
2.	603 (600) kHz
3.	Line out. T3
4.	Maximum output

6	DISTORTION
1.	999 (1000) kHz 74 dBu
2.	999 (1000) kHz
3.	Line out. Confirmation
4.	Less than 2%

NOTES:

1. Set the S.S.G. to 30% 1 kHz of each.
2. Confirm that the sensitivity margin between Low and High Range sensitivities is within 6 dBu, otherwise readjust Low and High Range sensitivity.
3. () kHz in result & Remarks indicates the test frequencies is AM-10 kHz STEP area.

3	MW HIGH RANGE SENSITIVITY
1.	1404 (1400) kHz 60 dBu
2.	1404 (1400)
3.	Line out. VC1
4.	Within 10% distortion factor.

2	MW LOW RANGE SENSITIVITY
1.	603 (600) kHz 60 dBu
2.	603 (600) kHz
3.	Line out. T1
4.	Within 10% distortion factor.

1	MW OSC
1.	No signal input
2.	1404 (1400) kHz
3.	Connect the DC Voltmeter between TP5 and GND. T2
4.	$6.7 \pm 0.15V$

4	
	For best result, repeat steps 2 and 3 two or three times.

4-3. MODEL AV-M313S TUNER ADJUSTMENT

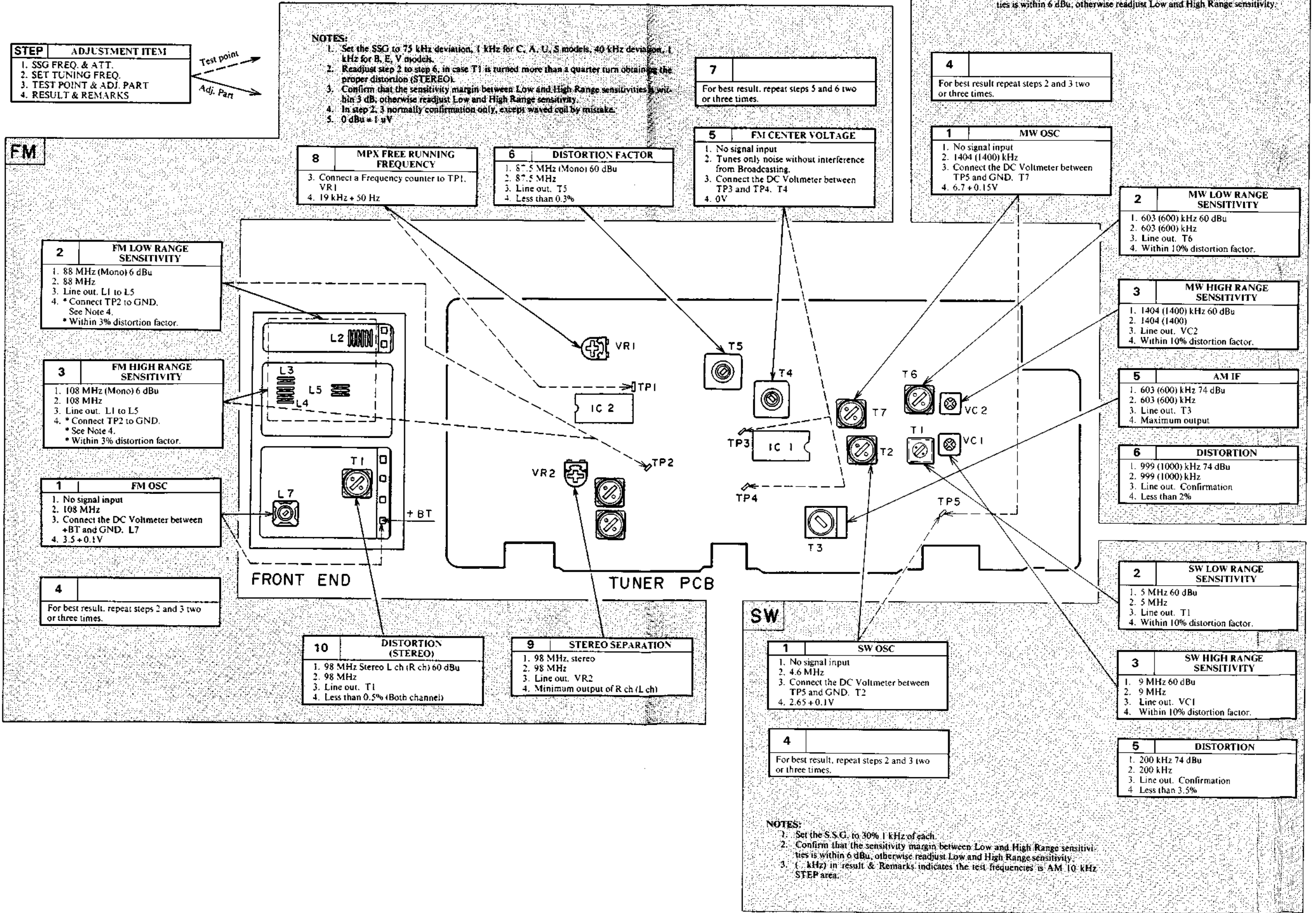

V. PARTS LIST

ATTENTION

1. When placing an order for parts, be sure to list Part No., Model No. and the description of each part. Otherwise, the non-delivery of the part or the delivery of a wrong part may result.
2. Please make sure that Part No. is correct when ordering.
If not, a part different from the one you ordered may be delivered.
3. Since the parts shown in Parts List of Preliminary Service Manual may have been the subject of changes, please use this Parts List for all future reference.

HOW TO USE THIS PARTS LIST

1. This Parts List lists those parts which are considered necessary for repairs. Other common parts, such as resistors and capacitors, are listed in the "Common List for Service Parts" from which these parts should be selected and stocked.
2. The Recommended Spare Parts List shows those parts in the Parts List which are considered particularly important for service.
3. Parts not shown in the Parts List and "Common List for Service Parts" will not in principle be supplied.
4. How to read the Parts List.

a) Mechanism Block

b) PC Board

2. HEAD BASE BLOCK

REF. NO.	PART NO.	DESCRIPTION
2-1x	BH-T2023A320A	HEAD BASE BLOCK
2-2	HP-H2206A010A	HEAD R/P PR4-8FU C
2-3	ZS-477876	PAN20x03STL CMT
2-4	ZS-536488	BID20x08STL CMT
2-5	ZG-402895	SP CS ANGLE ADJUST

SP (Service Parts) Classification

A small "x" indicates that this part is not shown in the Photo or Illustration.

This number corresponds with the individual parts index number in that figure.

This number corresponds with the Figure Number.

6. MAIN PC BOARD

REF. NO.	PART NO.	DESCRIPTION
6-IC1	EI-324536	IC HD14049BP
6-IC2	EI-336801	IC MB8841-564M
6-C1A	EC-338399	C MMY V 223M 250AC [U,E,B,S]
6-C1B	EC-350949	C MMY V 223M 250DC [J]
6-C1C	EC-338397	C MMY V 223M 125AC [C,A]
6-X1	EI-318384	OSC X'TAL NC-18C

Symbols for primary destination

[A]: AAL(U.S.A.) [S]: SAA(Australia)

[B]: BEAB(England) [U]: U/T(Universal Area)

[C]: CSA(Canada) [V]: VDE(W.Germany)

[E]: CEE(Europe) [Y]: Custom Version

[J]: JPN(Japan)

SP (Service Parts) Classification

These reference symbols correspond with component symbols in the Schematic Diagrams.

The available PC Board Blocks are listed separately.

5. When Part No. is known, Parts Index at end of Parts List can be used to locate where that part is shown in Parts List by its Reference No. listed at right of Part No.

WARNING

⚠ (*) INDICATES SAFETY CRITICAL COMPONENTS. FOR CONTINUED SAFETY, REPLACE SAFETY CRITICAL COMPONENTS ONLY WITH MANUFACTURE'S RECOMMENDED PARTS.

AVERTISSEMENT

⚠ (*) IL INDIQUE LES COMPOSANTS CRITIQUES DE SÉCURITÉ. POUR MAINTENIR LE DEGRÉ DE SÉCURITÉ DE L'APPAREIL, NE REMPLACER QUE DES PIÈCES RECOMMANDÉES PAR LE FABRICANT.

1. P.C BOARD BLOCK

Ref. No.	Part No.	Description
1-1	BA-A1018A020A	PC TUNER BLK AV-M313S(U)
1-1A	BA-A1018A020B	PC TUNER BLK AV-M313S(C,A)
1-1B	BA-A1018A020C	PC TUNER BLK AV-M313S(S)
1-1C	BA-A1018A020E	PC TUNER BLK AV-M313L(E,B)
1-1D	BA-A1018A020F	PC TUNER BLK AV-M313L(V)
1-2	BA-F0142A010A	PC FRONT END BLK FE42(U,C,A,S) [U.C.A.S]
1-2A	BA-F0142A010E	PC FRONT END BLK FE42(L,E,B)) [E.B]
1-2B	BA-F0142A010B	PC FRONT END BLK FE42(V) [V]
1-3	BA-A1018A030A	PC MAIN BLK AV-M313S(U)
1-3A	BA-A1018A030B	PC MAIN BLK AV-M313S(C)
1-3B	BA-A1018A030C	PC MAIN BLK AV-M313S(S)
1-3C	BA-A1018A030D	PC MAIN BLK AV-M313L(E)
1-3D	BA-A1018A030F	PC MAIN BLK AV-M313KL(V)
1-3E	BA-A1018A030G	PC MAIN BLK AV-M313L(B)
1-4	BA-A1018A070A	PC(≠) CPU BLK AV-M313A(U)
1-4A	BA-A1018A070B	PC(≠) CPU BLK AV-M313S(C,A)
1-5	BA-A1018A050A	PC FUNCTION BLK AV-M313S [EXCEPT V]
1-5A	BA-A1018A050B	PC FUNCTION BLK AV-M313L(V)
1-6	BA-A1018A080A	PC(≠) LCD BLK AV-M313S

NOTE:

- PC MAIN BLK consists of following PC BOARDS.
*MAIN PC BOARD *FILTER PC BOARD
- PC CPU BLK consists of following PC BOARDS.
*CPU (A) PC BOARD *CPU (B) PC BOARD
*PHONE J PC BOARD *POWER SW PC BOARD
- PC FUNCTION BLK consists of following PC BOARDS.
*FUNCTION (A) PC BOARD
*FUNCTION (B) PC BOARD
- PC LCD BLK consists of following PC BOARD
*LCD PC BOARD *SURROUND PC BOARD

2. TUNER P.C BOARD

Ref. No.	Part No.	Description
2-IC1	EI-361624	IC LA1265
2-IC2	EI-351849	IC UPC1235C
2-TR1	ET-356437	TR 2SC930 D2,E,F
2-TR2	ET-360067	TR 2SC3330 T,U F05
2-TR3	ET-360067	TR 2SC3330 T,U F05
2-TR4	ET-353899	TR 2SA1317 S,T,U
2-TR5	ET-353899	TR 2SA1317 S,T,U
2-TR6	ET-353899	TR 2SA1317 S,T,U
2-TR7	ET-360067	TR 2SC3330 T,U F05
2-TR8	ET-360067	TR 2SC3330 T,U F05
2-TR9	ET-336410	TR 2SC2878 A,B [E.B,V]
2-TR10	ET-356437	TR 2SC930 D2,E,F [U.C.A.S]
2-TR11	ET-349449	TR FET 2SK161 O,Y
2-TR22	ET-366413	TR FET 2SJ105 GR
2-TR24	ET-360067	TR 2SC3330 T,U F05
2-D1	ED-344280	D SILICON H GMA-01-FY2 F05
2-D2	ED-344280	D SILICON H GMA-01-FY2 F05
2-D3	ED-321180	D ZENER H HZ9 B2
2-D4	ED-360980	D SILICON V 1S2186GR F05 [U.C.A.S]
2-D4A	ED-344280	D SILICON H GMA-01-FY2 F05 [E.B,V]
2-D5	ED-344280	D SILICON H GMA-01-FY2 F05
2-D6	ED-349460	D VARACTOR SVC321 A,B,C,D DBL

Ref. No.	Part No.	Description
2-D7	ED-349460	D VARACTOR SVC321 A,B,C,D DBL
2-D26	ED-360980	D SILICON V 1S2186GR F05
2-VR1	EV-358576	R S-FIX H RH0615CS3J 3P 472
2-VR2	EV-361673	R S-FIX H RH0615CN5J 3P 334
2-FL1	EH-355568	FILTER CE SFE10.7MS2GY-A
2-FL2	EH-355568	FILTER CE SFE10.7MS2GY-A
2-FL3	EH-364675	FILTER LC LP 105-5028-01
2-FL4	EH-364675	FILTER LC LP 105-5028-01
2-FL5	EH-363344	FILTER LC LP 123-5010-03 [V]
2-L3	EO-365147	COIL FIX 1 LAL03NA 390K [U.C.A.S]
2-T1	EO-337598	COIL VARI 2 25A-1353-01 [E,B,V]
2-T1A	EO-362293	COIL VARI 2 25A-5409 [U.C.A.S]
2-T2	EO-363327	COIL OSC 2 A119AN-16792N [U.C.A.S]
2-T2A	EO-363279	COIL OSC 2 A7NRS-9857X 150.0UH [E,B,V]
2-T3	EO-361628	COIL IFT CFMA-027 450.0KHZ [U.C.A.S]
2-T3A	EO-356732	COIL IFT BCFL2-450A [E,B,V]
2-T4	EO-363291	COIL DET 2 78-1128-01
2-T5	EO-361630	COIL DET 2 78-1126-02
2-T6	EO-337598	COIL VARI 2 25A-1354-03 [E,B,V]
2-T6A	EO-337598	COIL VARI 2 25A-1353-01 [U.C.A.S]
2-T7	EO-363279	COIL OSC 2 A7NRS-9857X 150.0UH [U.C.A.S]
2-T7A	EO-352089	COIL OSC 2 7BRS-9098X 580.0UH [E,B,V]
2-R6	*ER-327710	R CB H S10 FS RDS 1/4W 151J
2-R34	*ER-200939	R CB H S10 FS RDS 1/4W 181J
2-R60	*ER-322591	R CB H S10 FS RDS 1/4W 101J
2-VC1	EC-363331	C S-FIX H CTC-6U-030 5.5-30
2-VC2	EC-359065	C S-FIX H CTC-6U-020 4.3-20 [U.C.A.S]
2-VC2A	EC-365146	C S-FIX H CTC-6U-050 9.1-50 [E,B,V]
2-C27	EC-334072	C STY V F05 CQ09S 431J 50DC [E,B,V]
2-C27A	EC-327096	C STY V F05 CQ09S 222J 50.0DC [U.C.A.S]
2-C28	EC-334068	C STY V F05 CQ09S 271J 50DC [E,B,V]
2-C28A	EC-334072	C STY V F05 CQ09S 431J 50DC [U.C.A.S]
2-C34	EC-306987	C STY V F05 500 471J 500C
2-C43	EC-317623	C STY V F05 500 102J 500C [U.S]
2-C43A	EC-334421	C STY V F05 500 182J 500C [C,A]
2-C43B	EC-316150	C STY V F05 500 821J 500C [E,B,V]
2-C44	EC-317623	C STY V F05 500 102J 500C [U.S]
2-C44A	EC-334421	C STY V F05 500 182J 500C [C,A]
2-C44B	EC-316150	C STY V F05 500 821J 500C [E,B,V]

3. FRONT END P.C BOARD

Ref. No.	Part No.	Description
3-TR1	ET-355556	TR FET 2SK241 Y
3-TR2	ET-336869	TR 2SC2999 C,D
3-TR3	ET-328265	TR 2SC930 F
3-TR4	ET-349449	TR FET 2SK161 O,Y
3-D1	ED-349448	D VARACTOR 1SV147
3-D2	ED-349448	D VARACTOR 1SV147

Ref. No.	Part No.	Description
3-D3	ED-349448	D VARACTOR 1SV147
3-D4	ED-349448	D VARACTOR 1SV147
3-D5	ED-344280	D SILICON H GMA-01-FY2 F05 [U.C.A.S.]
3-L1	EO-349461	COIL FIX 2 LINK
3-L2	EO-349462	COIL FIX 2 U147
3-L3	EO-349461	COIL FIX 2 LINK
3-L4	EO-349462	COIL FIX 2 U147
3-L5	EO-349462	COIL FIX 2 U147
3-L6	EO-359056	COIL FIX 1 LAL03NA 2R2M
3-L7	EO-353687	COIL OSC 2 E525HN-110003
3-T1	EO-337640	COIL IFT 119AC-15533X 10.7MHZ

Ref. No.	Part No.	Description
4-RL1	EQ-344440-A	RELAY SIG G2VN-287P 2TR 24V
4-SW1	ES-361613	SW PUSH SPPJ4 TYPE 02-02N
4-SW2	ES-360115	SW SLIDE 00120262 01-02S [U]
4-L1	EO-337880	COIL FIX 2 202AK-018 2R2K
4-L101	EO-345907	COIL FIX 1 LAL03KH 3R3K [U.C.A.S.]
4-X101	EI-344422	OSC X'TAL HC-18//U 7.200MHZ
4-FR1	*ER-328278	R FUSE ERD2FC 1/4W 10ROG
4-FR2	*ER-328278	R FUSE ERD2FC 1/4W 10ROG
4-FR3	*ER-345751	R FUSE ERD2FC S10 1/4W 15ROG
4-FR4	*ER-345751	R FUSE ERD2FC S10 1/4W 15ROG
4-FR5	*ER-328278	R FUSE ERD2FC 1/4W 10ROG
4-FR6	*ER-318647	R FUSE ERD2FC S10 1/4W 4R7J
4-R11	*ER-325269	R CB H S10 FS RDS 1/4W 222J
4-R14	*ER-359266	R OMF H S12 FS 1W 100J
4-R15	*ER-359266	R OMF H S12 FS 1W 100J
4-R18	*ER-333405	R CB H S10 FS RDS 1/4W 362J
4-R26	*ER-333355	R CB H S10 FS RDS 1/4W 103J
4-R27	*ER-302241	R CB H S10 FS RDS 1/4W 4R7J
4-R28	ER-333405	R CB H S10 FS RDS 1/4W 362J
4-R31	*ER-362228	R OMF H FS 1W 750J
4-R45	*ER-359738	R OMF H S15 FS 1W 151J [U.C.A.S.]

4. MAIN P.C BOARD

Ref. No.	Part No.	Description
4-IC1	*EI-358554	IC STK4152-2
4-IC101	EI-361622	IC LM7001
4-TR1	*ET-360687	TR 2SB1015 Y,GR
4-TR2	ET-359827	TR FET 2SK246 BL
4-TR3	ET-345626	TR 2SA1248 S.T
4-TR4	ET-337759	TR FET 2SK246 GR
4-TR5	*ET-349459	TR 2SD1406 O,Y,GR
4-TR6	ET-359827	TR FET 2SK246 BL
4-TR7	*ET-345625	TR 2SC3116 S.T
4-TR8	ET-337759	TR FET 2SK246 GR
4-TR9	*ET-349459	TR 2SD1406 O,Y,GR
4-TR10	ET-359827	TR FET 2SK246 BL
4-TR11	*ET-349459	TR 2SD1406 O,Y,GR
4-TR12	ET-359827	TR FET 2SK246 BL
4-TR13	*ET-349459	TR 2SD1406 O,Y,GR
4-TR14	ET-337759	TR FET 2SK246 GR
4-TR15	ET-338565	TR 2SD1302 R.S
4-TR16	ET-308472	TR 2SA1115 E.F,G F05
4-TR17	*ET-345625	TR 2SC3116 S.T
4-TR18	ET-200986	TR 2SD863-V8 F
4-TR19	*ET-307195	TR 2SC2240 GR,BL
4-TR20	ET-360067	TR 2SC3330 T,U F05
4-TR21	ET-360067	TR 2SC3330 T,U F05
4-TR22	ET-360067	TR 2SC3330 T,U F05
4-TR23	ET-360067	TR 2SC3330 T,U F05
4-TR101	ET-360067	TR 2SC3330 T,U F05 [EXCEPT L]
4-TR102	ET-360067	TR 2SC3330 T,U F05 [EXCEPT L]
4-TR103	ET-360067	TR 2SC3330 T,U F05
4-TR104	ET-337759	TR FET 2SK246 GR
4-D1	*ED-350748	D SILICON DBA60-K15 200/1.0A
4-D2	*ED-353550	D SILICON DBA30-C-K12 200/3.0A
4-D3	*ED-348990	D SILICON H DS446
4-D4	*ED-348990	D SILICON H DS446
4-D5	ED-346618	D ZENER H HZ15 1
4-D6	ED-361916	D ZENER H HZS10J F05 B1
4-D7	ED-346618	D ZENER H HZ15 1
4-D8	ED-361916	D ZENER H HZS10J F05 B1
4-D9	ED-346618	D ZENER H HZ15 1
4-D10	ED-315759	D ZENER H HZ16 1
4-D11	ED-346618	D ZENER H HZ15 1
4-D12	ED-301911	D SILICON H DS448
4-D13	ED-329056	D ZENER H HZ22 2
4-D14	ED-301911	D SILICON H DS448
4-D15	ED-348990	D SILICON H DS446
4-D16	ED-329051	D ZENER H HZ24 3
4-D17	ED-329057	D ZENER H HZ11 A1
4-D18	ED-301911	D SILICON H DS448
4-D19	ED-301911	D SILICON H DS448
4-D101	ED-360980	D SILICON V 1S2186GR F05 [U.C.A.S.]
4-D102	ED-301911	D SILICON H DS448 [EXCEPT L]
4-D103	ED-331197	D ZENER H HZ6 C1
4-D105	ED-344280	D SILICON H GMA-01-FY2 F05 [EXCEPT L]

4-R118	*ER-359268	R OMF H S12 FS 1W 181J
4-R121	*ER-327710	R CB H S10 FS RDS 1/4W 151J
4-VC1	EC-324938	C CE V F05 F 473Z 50F [V]
4-VC2	EC-200809	C CE V F05 F 103Z 50DC [V]
4-VC3	EC-200809	C CE V F05 F 103Z 50DC [V]
4-C1	EC-364328	C EC V CUT 682M 50DC
4-C2	EC-364328	C EC V CUT 682M 50DC
4-C5	EC-316231	C EC V CUT AS1 222M 35.0DC
4-C45	EC-320548	C CE V F 103Z 250AC
4-C46	EC-320548	C CE V F 103Z 250AC
4-J10	EJ-361614	PIN J JPJ2032-01-030 WHITE
4-J11	EJ-361615	PIN J JPJ2032-01-020 RED
4-TM1	EJ-359264	TERMINAL LEVER YKD21-0023A P 4P
4-TM2	EJ-359031	TERMINAL LEVER YKD31-0215 P 2P
4-1	BA-F0142A010A	PC FRONT END BLK FE42(U.C.A.S.) [U.C.A.S.]
4-1A	BA-F0142A010E	PC FRONT END BLK FE42(L,E,B) [E,B]
4-1B	BA-F0142A010B	PC FRONT END BLK FE42(V) [V]
4-F1	*EF-326613	FUSE TSC A 250V 5.00A [U]
4-F1A	*EF-346139	FUSE TSC 125V 5.00A [C,A]
4-F1B	*EF-690996	FUSE SEMKO T 250V 4.00A [E,V,S]
4-F1C	*EF-359086	FUSE BET T 250V 4.00A [B]
4-F2	*EF-326613	FUSE TSC A 250V 5.00A [U]
4-F2A	*EF-346139	FUSE TSC 125V 5.00A [C,A]
4-F2B	*EF-690996	FUSE SEMKO T 250V 4.00A [E,V,S]
4-F2C	*EF-359086	FUSE BET T 250V 4.00A [B]
4-F3	*EF-306950	FUSE TSC A 250V 2.00A [U]
4-F3A	*EF-306954	FUSE TSC 125V 2.00A [C,A]
4-F3B	*EF-601964	FUSE SEMKO T 250V 1.60A [E,V,S]
4-F3C	*EF-364518	FUSE BET T 250V 2.50A [B]
4-F4	*EF-326639	FUSE TSC A 250V 3.15A [U]
4-F4A	*EF-323080	FUSE TSC 125V 3.15A [C,A]
4-F4B	*EF-623125	FUSE SEMKO T 2250V 2.50A [E,V,S]
4-F4C	*EF-359343	FUSE BET T 250V 1.60A [B]

Ref. No.	Part No.	Description
4-F5	*EF-326639	FUSE TSC A 250V 3.15A [U]
4-F5A	*EF-323080	FUSE TSC 125V 3.15A [C.A]
4-F5B	*EF-623125	FUSE SEMKO T 2250V 2.50A [E.V.S]
4-F5C	*EF-364518	FUSE 8ET T 250V 2.50A [B]

5. CPU (A) P.C BOARD

Ref. No.	Part No.	Description
5-IC1	EI-356370	IC LA7224
5-IC2	EI-347120	IC SN74LS145N
5-IC3	EI-347120	IC SN74LS145N
5-IC4	EI-364519	IC LB1417
5-IC5	EI-359053	IC LA3600
5-TR1	ET-360067	TR 2SC3330 T,U FO5 [U]
5-D1	ED-301911	D SILICON H DS448 [E.B.V]
5-D3	ED-301911	D SILICON H DS448 [C.A]
5-D4	ED-361802	D LED GL-5NG27 GREEN
5-D5	ED-361802	D LED GL-5NG27 GREEN
5-D6	ED-361802	D LED GL-5NG27 GREEN
5-D7	ED-361802	D LED GL-5NG27 GREEN
5-D8	ED-361802	D LED GL-5NG27 GREEN
5-D9	ED-361802	D LED GL-5NG27 GREEN
5-D10	ED-361802	D LED GL-5NG27 GREEN
5-D11	ED-361802	D LED GL-5NG27 GREEN
5-D12	ED-361802	D LED GL-5NG27 GREEN
5-D13	ED-361802	D LED GL-5NG27 GREEN
5-D14	ED-361802	D LED GL-5NG27 GREEN
5-D15	ED-361802	D LED GL-5NG27 GREEN
5-D16	ED-361802	D LED GL-5NG27 GREEN
5-D17	ED-360409	D PHOT PN323B
5-SW1	ES-359988	SW TACT SKHHAN
5-SW2	ES-359988	SW TACT SKHHAN
5-SW3	ES-359988	SW TACT SKHHAN
5-SW4	ES-359988	SW TACT SKHHAN
5-SW5	ES-359988	SW TACT SKHHAN
5-SW6	ES-359988	SW TACT SKHHAN
5-SW7	ES-359988	SW TACT SKHHAN
5-SW8	ES-359988	SW TACT SKHHAN
5-SW9	ES-359988	SW TACT SKHHAN
5-SW10	ES-359988	SW TACT SKHHAN
5-SW11	ES-359988	SW TACT SKHHAN
5-SW12	ES-359988	SW TACT SKHHAN
5-SW13	ES-359988	SW TACT SKHHAN
5-SW14	ES-359988	SW TACT SKHHAN
5-SW15	ES-359988	SW TACT SKHHAN
5-SW16	ES-359988	SW TACT SKHHAN
5-SW17	ES-359988	SW TACT SKHHAN
5-SW18	ES-359988	SW TACT SKHHAN
5-SW19	ES-359988	SW TACT SKHHAN
5-SW20	ES-359988	SW TACT SKHHAN
5-SW21	ES-349367	SW TACT SKHHAK003A
5-SW22	ES-349367	SW TACT SKHHAK003A
5-SW23	ES-349367	SW TACT SKHHAK003A
5-SW24	ES-349367	SW TACT SKHHAK003A
5-SW25	ES-359988	SW TACT SKHHAN
5-SW26	ES-359988	SW TACT SKHHAN
5-VR1	EV-361635	VR SLIDE S302GN 503
5-VR2	EV-359083	VR SLIDE 30PSVOH MN254
5-VR3	EV-361636	VR SLIDE 30P2SVOI W104 W/CLICK
5-VR4	EV-361636	VR SLIDE 30P2SVOI W104 W/CLICK
5-VR5	EV-361636	VR SLIDE 30P2SVOI W104 W/CLICK
5-VR6	EV-361636	VR SLIDE 30P2SVOI W104 W/CLICK
5-VR7	EV-361636	VR SLIDE 30P2SVOI W104 W/CLICK
5-L1	EO-330719	COIL FIX 1 187LY-103K 103K

6. CPU (B) P.C BOARD

Ref. No.	Part No.	Description
6-IC1	EI-337228	IC M5218L
6-IC2	EI-337228	IC M5218L
6-IC3	EI-337228	IC M5218L
6-IC4	EI-361637	IC TC9155AP
6-IC5	EI-200573	IC TC4053BP
6-IC6	EI-337228	IC M5218L
6-IC7	EI-361638	IC TC9153AP
6-IC101	EI-362325	IC V313-6359 CUSTOM [U.C.A.S]
6-IC101A	EI-364634	IC A1018-6358 [E.B.V]
6-TR1	ET-351872	TR 2SC3383 R,S
6-TR2	ET-351872	TR 2SC3383 R,S
6-TR3	ET-351872	TR 2SC3383 R,S
6-TR4	ET-361640	TR RN1205
6-TR5	ET-360067	TR 2SC3330 T,U FO5
6-TR6	ET-361640	TR RN1205
6-TR7	ET-360067	TR 2SC3330 T,U FO5
6-TR8	ET-352726	TR 2SA1392 T,U
6-TR101	ET-208012	TR 2SD571 K
6-D1	ED-344280	D SILICON H GMA-01-FY2 FO5
6-D2	ED-344280	D SILICON H GMA-01-FY2 FO5
6-D3	ED-337266	D ZENER H HZ9 A1
6-D4	ED-344280	D SILICON H GMA-01-FY2 FO5
6-D5	ED-344280	D SILICON H GMA-01-FY2 FO5
6-D6	ED-344280	D SILICON H GMA-01-FY2 FO5
6-D7	ED-344280	D SILICON H GMA-01-FY2 FO5
6-D8	ED-337266	D ZENER H HZ9 A1
6-D9	ED-301911	D SILICON H DS448
6-D10	ED-346603	D ZENER H HZ6 A1
6-D12	ED-301911	D SILICON H DS448
6-D13	ED-301911	D SILICON H DS448
6-D14	ED-309069	D ZENER H HZ6 B2
6-D15	ED-344280	D SILICON H GMA-01-FY2 FO5
6-D16	ED-344280	D SILICON H GMA-01-FY2 FO5
6-D17	ED-344280	D SILICON H GMA-01-FY2 FO5
6-D18	ED-344280	D SILICON H GMA-01-FY2 FO5
6-D19	ED-301911	D SILICON H DS448
6-D20	ED-330962	D ZENER H HZ4 C1
6-D21	ED-344280	D SILICON H GMA-01-FY2 FO5
6-D22	ED-301911	D SILICON H DS448
6-D23	ED-344280	D SILICON H GMA-01-FY2 FO5
6-D24	ED-301911	D SILICON H DS448
6-D101	ED-337265	D ZENER H HZ6 C2
6-D102	ED-309069	D ZENER H HZ6 B2
2-D103	ED-344280	D SILICON H GMA-01-FY2 FO5
6-D104	ED-344280	D SILICON H GMA-01-FY2 FO5
6-D105	ED-344280	D SILICON H GMA-01-FY2 FO5
6-D106	ED-344280	D SILICON H GMA-01-FY2 FO5
6-X101	EI-330256	OSC CE F85-006 4MHZ
6-SR101	EH-361668	COMP R RKC10DS 472J
6-SR102	EH-361668	COMP R RKC10DS 472J
6-SR103	EH-361669	COMP R RKC4BS 472J
6-SR104	EH-361670	COMP R RKC6BS 472J
6-FR101	*ER-200595	R FUSE ERD2FC S10 1/4W 5R6J
6-R46	*ER-324185	R CB H S10 FS RDS 1/4W 221J
6-R53	*ER-322331	R CB H S10 FS RDS 1/4W 221J
6-R101	*ER-359269	R OMF H S12 FS 1W 221J
6-R102	*ER-325289	R CB H S10 FS RDS 1/4W 222J
6-1	EJ-362280	SOCKET IC S-I2482 42P

7. FUNCTION (A) P.C BOARD

Ref. No.	Part No.	Description
7-IC1	EI-349392	IC TC9164N
7-IC2	EI-349719	IC M5218P
7-D1	ED-301911	D SILICON H DS448
7-D2	ED-301911	D SILICON H DS448
7-VL1	EO-345918	COIL FIX 1 LAL03KH 220K [V]
7-VL2	EO-345918	COIL FIX 1 LAL03KH 220K [V]
7-VL3	EO-345918	COIL FIX 1 LAL03KH 220K [V]
7-VL4	EO-345918	COIL FIX 1 LAL03KH 220K [V]
7-VL5	EO-345918	COIL FIX 1 LAL03KH 220K [V]
7-J1	EJ-343365	PIN J YMC21-0063 P 4P
7-J2	EJ-343365	PIN J YMC21-0063 P 4P
7-J3	EJ-362033	PHONE J 3P HSJ1406 3.5

8. FUNCTION (B) P.C BOARD

Ref. No.	Part No.	Description
8-IC1	EI-353852	IC LA7016
8-TR1	ET-308141	TR 2SC2603 G F05
8-TR2	ET-308141	TR 2SC2603 G F05
8-TR3	ET-308141	TR 2SC2603 G F05
8-TR4	ET-308141	TR 2SC2603 G F05
8-VL1	EO-345918	COIL FIX 1 LAL03KH 220K [V]
8-VL2	EO-345918	COIL FIX 1 LAL03KH 220K [V]
8-VL3	EO-345918	COIL FIX 1 LAL03KH 220K [V]
8-R7	*ER-322591	R CB H S10 FS RDS 1/4W 101J
8-R8	*ER-322591	R CB H S10 FS RDS 1/4W 101J
8-R9	ER-365172	R OMF H S12 FS 1W 331J
8-J1	EJ-356658	PIN J 1T-31K0425 10P

9. PHONE JACK P.C BOARD

Ref. No.	Part No.	Description
9-SW1	ES-359071	SW PUSH ESB-62771 2-02-02N
9-VL1	EO-336934	COIL FIX 1 LAL03KH 2R2M
9-VL2	EO-336934	COIL FIX 1 LAL03KH 2R2M
9-R2	ER-359268	R OMF H S12 FS 1W 181J
9-VC1	EC-316441	C CE H F10 B 221K 50DC [L]
9-VC2	EC-316441	C CE H F10 B 221K 50DC [L]
9-J1	EJ-349657	PHONE J 2P HSJ0922-050 3.5 C
9-J2	EJ-349658	PHONE J 2P HSJ0922-040 3.5 T

10. LCD P.C BOARD

Ref. No.	Part No.	Description
10-IC1	EI-361230	IC LC7580
10-LC1	EM-361644	IND LCD 9419P

11. SURROUND P.C BOARD

Ref. No.	Part No.	Description
11-IC1	EI-361645	IC IR2E34
11-IC2	EI-361645	IC IR2E34
11-IC3	EI-337228	IC M5218L
11-IC4	EI-337228	IC M5218L
11-TR1	ET-360067	TR 2SC3330 T,U F05
11-TR2	ET-360067	TR 2SC3330 T,U F05
11-TR3	ET-360067	TR 2SC3330 T,U F05
11-LCD1	EM-361646	IND LCD 9420P

12. POWER SW P.C BOARD

Ref. No.	Part No.	Description
12-SW1	*ES-361797	SW PUSH SDDLD1
12-C1	*EC-320548	C CE V F 103Z 250AC [U]
12-C1A	*EC-338411	C CE V FZ 103P 400AC [EXCEPT U]

13. FILTER P.C BOARD

Ref. No.	Part No.	Description
13-FL1	EO-338409	COIL LF FKOB160MH02 250UH [V]
13-R1	ER-356573	R SD ANTI-STATIC 1/2W 225K [C,A]
13-F6	*EF-306951	FUSE TSC A 250V 2.50A [U]
13-F7	*EF-306951	FUSE TSC A 250V 2.50A [U]

ASSEMBLY BLOCK

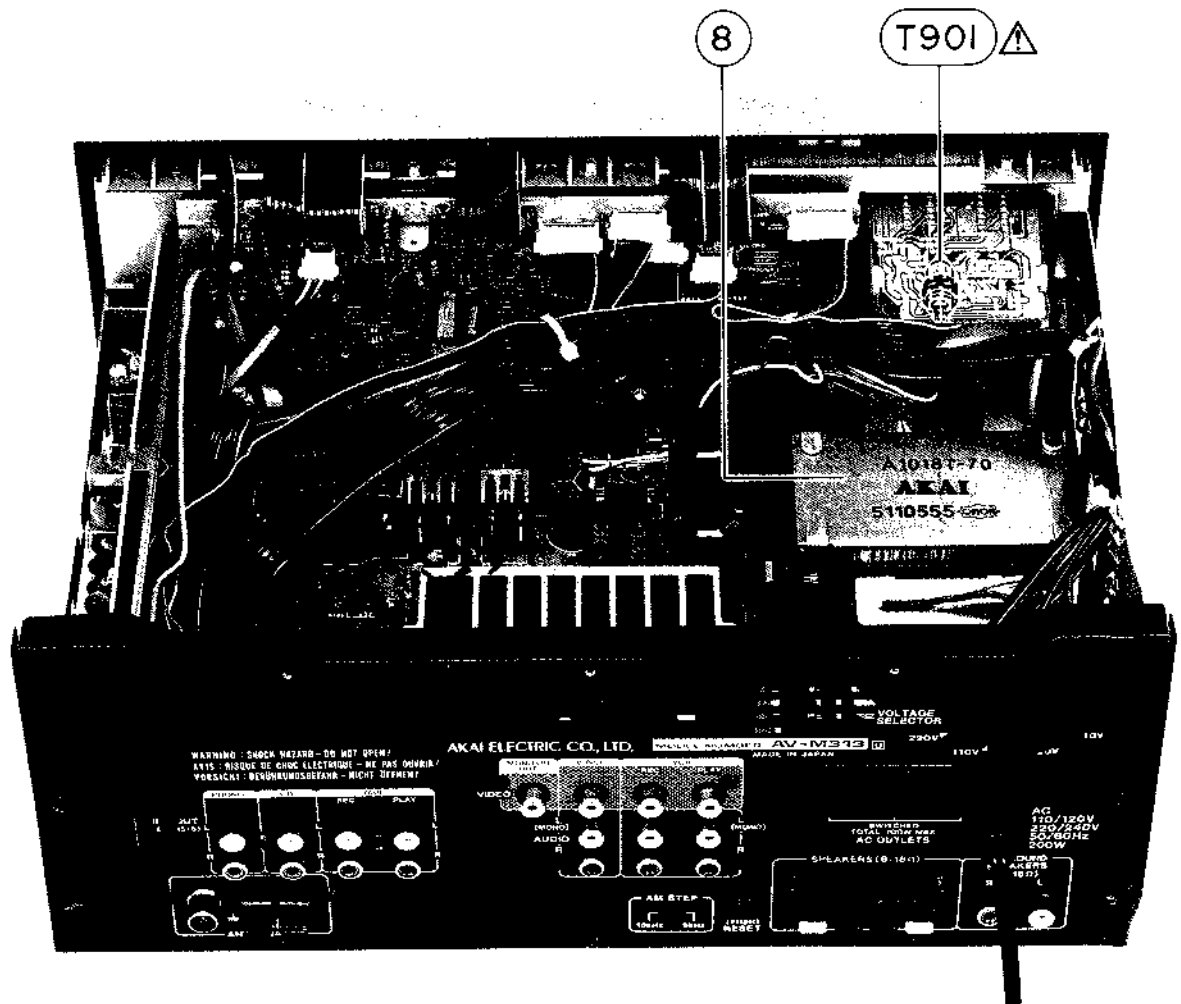
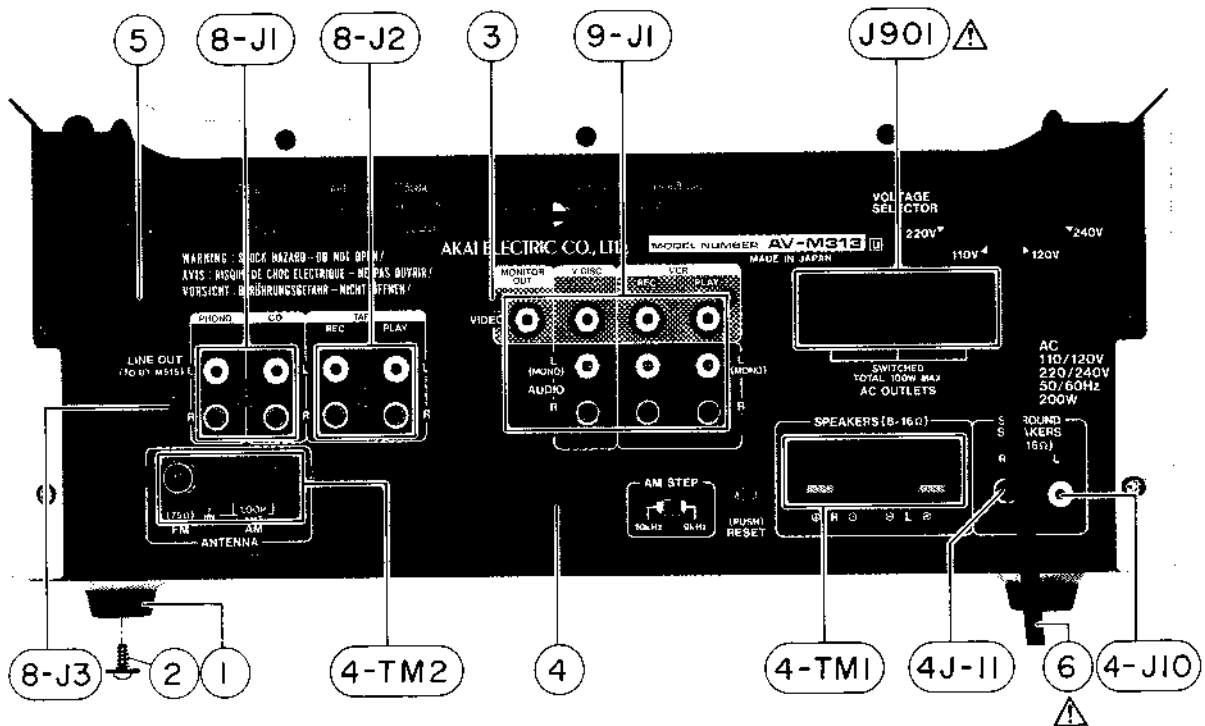

PARTS LIST

14. ASSEMBLY BLOCK

Ref. No.	Part No.	Description
14-1	SA-202118	FOOT
14-2	ZS-346742	ST BID40X08STL CMT CUP [TRANS POWER FIX]
14-3	ZW-898308	RV NYL30X055 BL
14-4	SP-361401E-A	PANEL REAR AV-M313(U)
14-4A	SP-361401B-A	PANEL REAR AV-M313(A,C)
14-4B	SP-361401C-A	PANEL REAR AV-M313(B,S)
14-4C	SP-361401D-A	PANEL REAR AV-M313(E,V)
14-5	SZ-362273	HOLDER ANTENNA (2)
14-6	*EW-363659	AC CORD 200 0129AVFF B070 A U/T [U]
14-6A	*EW-363647	AC CORD 200 238APSPT2 B070 A UC [C,A]
14-6B	*EW-363698	AC CORD 200 0436 LCFL B070 A S [S]
14-6C	*EW-363672	AC CORD 200 0364 LCFL B070 A EV [E,V]
14-6D	*EW-363684	AC CORD 200 LCFL B070 A B [B]
14-7	EE-359265	ANT LOOP LA-200A-A
14-8	ZS-308846	T2BR30X08STL BZN PROJECTION [COVER UPPER FIX]
14-9	ZS-311745	T2BR30X08STL BNI PW080 [COVER UPPER FIX]
14-T901	*BT-361595	TRANS POWER A1018T-70 [U]
14-T901A	*BT-361592	TRANS POWER A1018T-30 [C]
14-T901B	*BT-361591	TRANS POWER A1018T-20 [A]
14-T901C	*BT-361594	TRANS POWER A1018T-50 [S,B]
14-T901D	*BT-361593	TRANS POWER A1018T-40 [E]
14-T901E	*BT-361804	TRANS POWER A1018T-60 [V]
14-SW901	*ES-364594	SW SELECTOR YKS11-0012 02-4 [U]
14-J901	*EJ-364357	SOCKET OUTLET S2T-733T162 [U]
14-J901A	*EJ-364358	SOCKET OUTLET S2T-733T112 [C,A]
14-IN901	EL-361656	PL CORD 14.0V 100MA L = 260
14-IN902	EL-361656	PL CORD 14.0V 100MA L = 260
14-IN903	EL-361656	PL CORD 14.0V 100MA L = 260
14-L901	EO-362435	COIL FIX 1 LAL03NA R22M

FINAL ASSEMBLY BLOCK

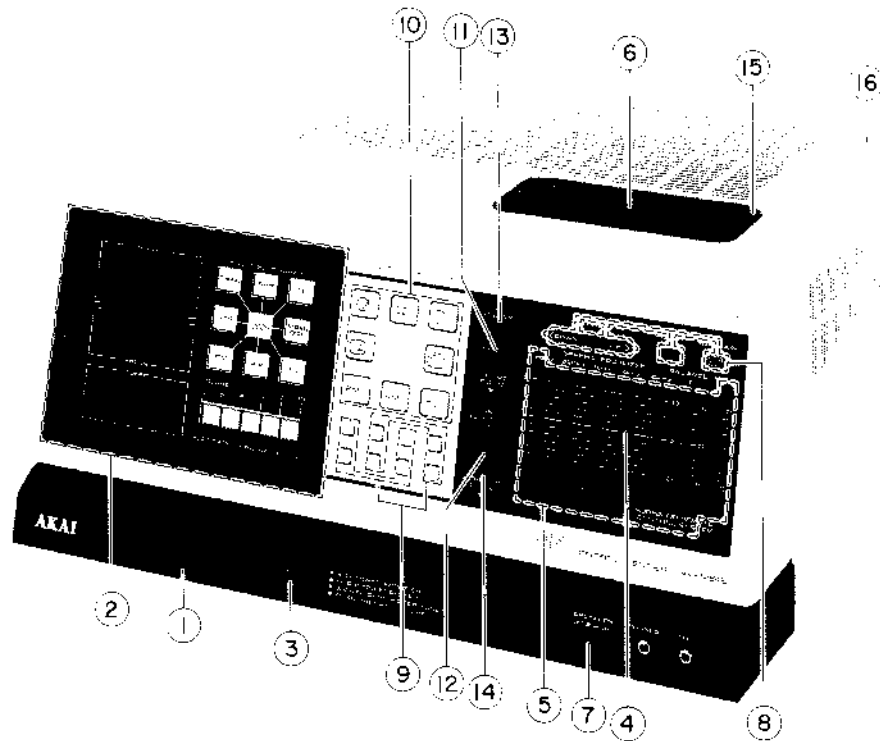

15. FINAL ASSEMBLY BLOCK

Ref. No.	Part No.	Description
15-1	BD-B361415D	PANEL FRONT M313 PART
15-1A	BD-B361415H	PANEL FRONT M313L PART
15-1-B	BD-B361415C	PANEL FRONT M313-B PART
15-1A-B	BD-B361415G	PANEL FRONT M313L-B PART
15-2	BD-B361429X3	PANEL WINDOW (3) PART
15-2A	BD-B361429X2	PANEL WINDOW (2) PART
15-3	EZ-361808	HOLDER LAMP EQ300-42101A WHITE
15-4	SK-361411	KNOB POWER
15-5	SK-361409	KNOB SLIDE
15-6	SP-361408	PLATE SLIDE
15-7	SK-361410	KNOB SP
15-8	SK-361418C	KNOB TUNING (2)
15-8-B	SK-361418D	KNOB TUNING (2)-B
15-9	SK-361425A	KNOB PRESET
15-9-B	SK-361425B	KNOB PRESET-B
15-10	SK-361420E	KNOB OPERATION (3)
15-10A	SK-361420C	KNOB OPERATION (2)
15-10-B	SK-361420F	KNOB OPERATION (3)-B
15-10A-B	SK-361420D	KNOB OPERATION (2)-B
15-11	SK-361421	KNOB MUTE
15-12	SK-361421B	KNOB MUTE(2)
15-13	SK-361419A	KNOB VR
15-13-B	SK-361419B	KNOB VR-B
15-14	SK-361419C	KNOB VR (2)
15-15X	ZS-331567	T2BR30X08STL CMT C080 'PANEL FRONT FIX'
15-16X	ZS-319460	T2BR30X06STL BZN PROJECTION 'PANEL FRONT FIX'
15-17	SP-361414C	COVER UPPER (3)
15-17-B	SP-361414D	COVER UPPER (4)
15-18X	EI-352118	SOCKET COAX PA1 82 714P-900

16. REMOTE CONTROL UNIT RC-M313

Ref. No.	Part No.	Description
16-1	AX-361747	REMOCON RC-M313 WIRELESS(1)
16-IC1	EI-749983	IC UPD1943G
16-TR1	ET-718040	TR 2SD1468
16-D1	ED-705414	D LED SE303A INFRARED
16-D2	ED-705414	D LED SE303A INFRARED
16-D3	ED-718039	D SILICON DAN201
16-D4	ED-557447	D SILICON H 1S1588
16-X1	EI-749984	OSC CE KBR455BAT 455KHZ
16-2	SC-718041	COVER BATTERY
16-3	SZ-718044	JOINT

SYMBOL FOR COLOR VARIATION

NON: STANDARD COLOR

-B: BLACK

INDEX

Part No.	Ref. No.	Part No.	Ref. No.	Part No.	Ref. No.	Part No.	Ref. No.
AX-361747	16-1	ED-329051	4-D16	EF-346139	4-F1A	EO-345918	7-VL1
BA-A1018A020A	1-1	ED-329056	4-D13	EF-346139	4-F2A	EO-345918	7-VL2
BA-A1018A020B	1-1A	ED-329057	4-D17	EF-359086	4-F1C	EO-345918	7-VL3
BA-A1018A020C	1-1B	ED-330962	6-D20	EF-359086	4-F2C	EO-345918	7-VL4
BA-A1018A020E	1-1C	ED-331197	4-D103	EF-359343	4-F4C	EO-345918	7-VL5
BA-A1018A020F	1-1D	ED-337265	6-D101	EF-364518	4-F3C	EO-345918	8-VL1
BA-A1018A030A	1-3	ED-337266	6-D3	EF-364518	4-F5C	EO-345918	8-VL2
BA-A1018A030B	1-3A	ED-337266	6-D3	EF-601964	4-F3B	EO-345918	8-VL3
BA-A1018A030C	1-3B	ED-344280	2-D1	EF-623125	4-F4B	EO-349461	3-L1
BA-A1018A030D	1-3C	ED-344280	2-D2	EF-623125	4-F5B	EO-349461	3-L3
BA-A1018A030F	1-3D	ED-344280	2-D4A	EF-690996	4-F1B	EO-349462	3-L2
BA-A1018A030G	1-3E	ED-344280	2-D5	EF-690996	4-F2B	EO-349462	3-L4
BA-A1018A050A	1-5	ED-344280	3-D5	EH-355568	2-FL1	EO-349462	3-L5
BA-A1018A050B	1-5A	ED-344280	4-D105	EH-355568	2-FL2	EO-352089	2-T7A
BA-A1018A070A	1-4	ED-344280	6-D1	EH-361668	6-SR101	EO-353687	3-L7
BA-A1018A070B	1-4A	ED-344280	6-D2	EH-361668	6-SR102	EO-356732	2-T3A
BA-A1018A080A	1-6	ED-344280	6-D4	EH-361669	6-SR103	EO-359056	3-L6
BA-F0142A010A	1-2	ED-344280	6-D5	EH-361670	6-SR104	EO-361628	2-T3
BA-F0142A010A	4-1	ED-344280	6-D6	EH-363344	2-FL5	EO-361630	2-T5
BA-F0142A010B	1-2B	ED-344280	6-D7	EH-364675	2-FL3	EO-362293	2-T1A
BA-F0142A010B	4-1B	ED-344280	6-D15	EH-364675	2-FL4	EO-362435	14-L901
BA-F0142A010E	1-2A	ED-344280	6-D16	EI-200573	6-IC5	EO-363279	2-T2A
BA-F0142A010E	4-1A	ED-344280	6-D17	EI-330256	6-X101	EO-363279	2-T7
BD-B361415C	15-1-B	ED-344280	6-D18	EI-337228	6-IC1	EO-363291	2-T4
BD-B361415D	15-1	ED-344280	6-D21	EI-337228	6-IC2	EO-363327	2-T2
BD-B361415E	15-1A-B	ED-344280	6-D23	EI-337228	6-IC3	EO-365147	2-L3
BD-B361415H	15-1A	ED-344280	2-D103	EI-337228	6-IC6	EQ-344440-A	4-RL1
BD-B361429X2	15-2A	ED-344280	6-D104	EI-337228	11-IC3	ER-200595	6-FR101
BD-B361429X3	15-2	ED-344280	6-D105	EI-337228	11-IC4	ER-200939	2-R34
BT-361591	14-T901B	ED-344280	6-D106	EI-344422	4-X101	ER-302241	4-R27
BT-361592	14-T901A	ED-346603	6-D10	EI-347120	5-IC2	ER-318647	4-FR6
BT-361593	14-T901D	ED-346618	4-D5	EI-347120	5-IC3	ER-322331	6-R53
BT-361594	14-T901C	ED-346618	4-D7	EI-349392	7-IC1	ER-322591	2-R60
BT-361595	14-T901	ED-346618	4-D9	EI-349719	7-IC2	ER-322591	8-R7
BT-361804	14-T901E	ED-346618	4-D11	EI-351849	2-IC2	ER-322591	4-R8
EC-200809	4-VC2	ED-348990	4-D3	EI-353852	8-IC1	ER-324185	6-R46
EC-200809	4-VC3	ED-348990	4-D4	EI-356370	5-IC1	ER-325269	4-R11
EC-306987	2-C34	ED-348990	4-D15	EI-358554	4-IC1	ER-325269	6-R102
EC-316150	2-C43B	ED-349448	3-D1	EI-359053	5-IC5	ER-327710	2-R6
EC-316150	2-C44B	ED-349448	3-D2	EI-361230	10-IC1	ER-327710	4-R12.1
EC-316231	4-C5	ED-349448	3-D3	EI-361622	4-IC101	ER-328278	4-FR1
EC-316441	9-VC1	ED-349448	3-D4	EI-361624	2-IC1	ER-328278	4-FR2
EC-316441	9-VC2	ED-349460	2-D6	EI-361637	6-IC4	ER-328278	4-FR5
EC-317623	2-C43	ED-349460	2-D7	EI-361638	6-IC7	ER-333355	4-R26
EC-317623	2-C44	ED-350748	4-D1	EI-361645	11-IC1	ER-333405	4-R18
EC-320548	4-C45	ED-353550	4-D2	EI-361645	11-IC2	ER-333405	4-R2B
EC-320548	4-C46	ED-360409	5-D17	EI-362325	6-IC101	ER-345751	4-FR3
EC-320548	12-C1	ED-360980	2-D4	EI-364518	5-IC4	ER-345751	4-FR4
EC-324938	4-VC1	ED-360980	2-D26	EI-364634	6-IC101A	ER-356573	13-R1
EC-327096	2-C27A	ED-360980	4-D101	EI-749983	16-IC1	ER-359266	4-R14
EC-334068	2-C28	ED-361802	5-D4	EI-749984	16-X1	ER-359266	4-R15
EC-334072	2-C27	ED-361802	5-D5	EJ-343365	7-J1	ER-359268	4-R11.8
EC-334072	2-C28A	ED-361802	5-D6	EJ-343365	7-J2	ER-359268	9R2
EC-334421	2-C43A	ED-361802	5-D7	EJ-349657	9-J1	ER-359269	6R10.1
EC-334421	2-C44A	ED-361802	5-D8	EJ-349658	9-J2	ER-359738	4-R45
EC-338411	12-C1A	ED-361802	5-D9	EJ-352118	15-18X	ER-362228	4-R31
EC-359065	2-VC2	ED-361802	5-D10	EJ-356658	8-J1	ER-365172	8R9
EC-363331	2-VC1	ED-361802	5-D11	EJ-359031	4-TM2	ES-349367	5SW21
EC-364328	4-C1	ED-361802	5-D12	EJ-359264	4-TM1	ES-349367	5SW22
EC-364328	4-C2	ED-361802	5-D13	EJ-361614	4-J10	ES-349367	5SW23
EC-365146	2-VC2A	ED-361802	5-D14	EJ-361815	4-J11	ES-349367	5SW24
ED-301911	4-D12	ED-361802	5-D15	EJ-362033	7-J3	ES-359071	9SW1
ED-301911	4-D14	ED-361802	5-D16	EJ-362280	6-1	ES-359988	5SW1
ED-301911	4-D18	ED-361916	4-D6	EJ-364357	14-J901	ES-359988	5SW2
ED-301911	4-D19	ED-361916	4-D8	EJ-364358	14-J901A	ES-359988	5SW3
ED-301911	4-D102	ED-557447	16-D4	EL-361656	14-IN901	ES-359988	5SW4
ED-301911	5-D1	ED-705414	16-D1	EL-361656	14-IN902	ES-359988	5SW5
ED-301911	5-D3	ED-705414	16-D2	EL-361656	14-IN903	ES-359988	5SW6
ED-301911	6-D9	ED-718039	16-D3	EM-361644	10-LC1	ES-359988	5SW7
ED-301911	6-D12	EE-359265	14-7	EM-361646	11-LCD1	ES-359988	5SW8
ED-301911	6-D13	EF-306950	4-F3	EO-330719	5-L1	ES-359988	5SW9
ED-301911	6-D19	EF-306951	13-F6	EO-336934	9-VL1	ES-359988	5SW10
ED-301911	6-D22	EF-306951	13-F7	EO-336934	9-VL2	ES-359988	5SW11
ED-301911	6-D24	EF-306954	4-F3A	EO-337598	2-T1	ES-359988	5SW12
ED-301911	7-D1	EF-323080	4-F4A	EO-337598	2-T6A	ES-359988	5SW13
ED-301911	7-D2	EF-323080	4-F5A	EO-337599	2-T6	ES-359988	5SW14
ED-309069	6-D14	EF-326613	4-F1	EO-337640	3-T1	ES-359988	5SW15
ED-309069	6-D102	EF-326613	4-F2	EO-337880	4-L1	ES-359988	5SW16
ED-315759	4-D10	EF-326639	4-F4	EO-338409	13-FL1	ES-359988	5SW17
ED-321180	2-D3	EF-326639	4-F5	EO-345907	4-L101	ES-359988	5SW18

Part No.	Ref. No.	Part No.	Ref. No.	Part No.	Ref. No.	Part No.	Ref. No.
ES-359988	5-SW19	EW-363659	14-6				
ES-359988	5-SW20	EW-363672	14-6C				
ES-359988	5-SW25	EW-363684	14-6D				
ES-359988	5-SW26	EW-363698	14-6B				
ES-360115	4-SW2	EZ-361808	15-3				
ES-361613	4-SW1	SA-202118	14-1				
ES-361797	12-SW1	SC-718041	16-2				
ES-364594	14-SW901	SK-361409	15-5				
ET-200986	4-TR18	SK-361410	15-7				
ET-208012	6-TR101	SK-361411	15-4				
ET-307195	4-TR19	SK-361418C	15-8				
ET-308141	8-TR1	SK-361418D	15-8-B				
ET-308141	8-TR2	SK-361419A	15-13				
ET-308141	8-TR3	SK-361419B	15-13-B				
ET-308141	8-TR4	SK-361419C	15-14				
ET-308472	4-TR16	SK-361420C	15-10A				
ET-328265	3-TR3	SK-361420D	15-10A-B				
ET-336869	3-TR2	SK-361420E	15-10				
ET-337759	4-TR4	SK-361420F	15-10-B				
ET-337759	4-TR8	SK-361421	15-11				
ET-337759	4-TR14	SK-361421B	15-12				
ET-337759	4-TR104	SK-361425A	15-9				
ET-338410	2-TR9	SK-361425B	15-9-B				
ET-338565	4-TR15	SP-361401B-A	14-4A				
ET-345625	4-TR7	SP-361401C-A	14-4B				
ET-345625	4-TR17	SP-361401D-A	14-4C				
ET-345626	4-TR3	SP-361401E-A	14-4				
ET-349449	2-TR11	SP-361408	15-6				
ET-349449	3-TR4	SP-361414C	15-17				
ET-349459	4-TR5	SP-361414D	15-17-B				
ET-349459	4-TR9	SZ-362273	14-5				
ET-349459	4-TR11	SZ-718044	16-3				
ET-349459	4-TR13	ZS-308846	14-8				
ET-351872	6-TR1	ZS-311745	14-9				
ET-351872	6-TR2	ZS-319460	15-16X				
ET-351872	6-TR3	ZS-331567	15-15X				
ET-352726	6-TR8	ZS-346742	14-2				
ET-353899	2-TR4	ZW-698308	14-3				
ET-353899	2-TR5						
ET-353899	2-TR6						
ET-355556	3-TR1						
ET-356437	2-TR1						
ET-356437	2-TR10						
ET-359827	4-TR2						
ET-359827	4-TR6						
ET-359827	4-TR10						
ET-359827	4-TR12						
ET-360067	2-TR2						
ET-360067	2-TR3						
ET-360067	2-TR7						
ET-360067	2-TR8						
ET-360067	2-TR24						
ET-360067	4-TR20						
ET-360067	4-TR21						
ET-360067	4-TR22						
ET-360067	4-TR23						
ET-360067	4-TR101						
ET-360067	4-TR102						
ET-360067	4-TR103						
ET-360067	5-TR1						
ET-360067	6-TR5						
ET-360067	6-TR7						
ET-360067	11-TR1						
ET-360067	11-TR2						
ET-360067	11-TR3						
ET-360687	4-TR1						
ET-361640	6-TR4						
ET-361640	6-TR6						
ET-366413	2-TR22						
ET-718040	16-TR1						
EV-356576	2-VR1						
EV-359083	5-VR2						
EV-361636	5-VR1						
EV-361636	5-VR3						
EV-361636	5-VR4						
EV-361636	5-VR5						
EV-361636	5-VR6						
EV-361636	5-VR7						
EV-361673	2-VR2						
EW-363647	14-6A						

ABBREVIATIONS FOR SERVICE MANUAL

ABBREVIATION	EXPLANATION	ABBREVIATION	EXPLANATION
AFC	Auto Frequency Control	MEMO	MEMOry
AGC	Auto Gain Control	MI-COM	MIcro-COMputer
ALC	Auto Level Control	MIN	MINimum
AM	Amplitude Modulation	MIX	MIXing
AMP	AMPlifier	MPX	MultiPleX
ANT	ANTenna	MW	Medium Wave (frequency)
BATT	BATTery	NC	No Connection
BLK	BLock	NFB	Negative Feed Back
BUFF	BUFFer	OSC	OSCillator
COMP	COMParator	PCB	Printed Circuit Board
DET	DETECT (DETECTOR)	PLL	Phase Locked Board
FLD		QD	Quadrature Detector
FM	Frequency Modulation	Rch	Right channel
FREQ	FREQuency	REF	REFerence
GND	GrouND	REG	REGulator
H	High	RF	Radio Frequency
HPF	High Pass Filter	SEG	SEGment
IF	Intermediate Frequency	SELE	SELEctor
IHF	Institute of High Fidelity	SENS	SENSitivity
IND	INDicator	SIG	SIGNAL
I/O	In/Out	S/N	Signal to Noise Ratio
JW	Jumper Wire	SSG	Standard Signal Generator
L	Low	STD	STANDARD
LCD	Liquid Crystal Display	SW	SWitch: Short Wave (frequency)
Lch	Left channel	THD	Total Harmonic Distortion
LED	Light Emitting Diode	TP	Test Point
LPF	Low Pass Filter	VCO	Voltage Controlled Oscillator
LW	Long Wave (Frequency)	VR	Variable Resistor
		X'TAL	Crystal

AKAI ELECTRIC CO., LTD.

12-14, 2-Chome, Higashi-Kojima, Ohta-Ku, Tokyo, Japan

TEL Tokyo (742) 5111 CABLE HIFIKAJI TOKYO TELEX J26261

Printed No. 861104-G1-3700

Printed Date: November 29, 1986

350 Printed in Japan

AKAI

MODEL AV-M313

SCHEMATIC DIAGRAM AND PC BOARDS

TABLE OF CONTENTS

1. ICs	2
2. POWER SUPPLY BLOCK DIAGRAM.....	4
3. SYS-CON BLOCK DIAGRAM	5
4. AMP BLOCK DIAGRAM.....	6
5. TUNER BLOCK DIAGRAM.....	7
6. CONNECTION DIAGRAM.....	8
7. FUSE, LCD, HEADPHONE PC BOARD	9
8. MAIN SCHEMATIC DIAGRAM.....	10
9. MAIN PC BOARD.....	11
10. FUNCTION (1)/(2) SCHEMATIC DIAGRAM	12
11. FUNCTION (1)/(2) PCB.....	13
12. CPU (1) SCHEMATIC DIAGRAM.....	14
13. CPU (1) PC BOARD.....	15
14. CPU (2) PC BOARD.....	16
15. CPU (2) SCHEMATIC DIAGRAM.....	17
16. TUNER SCHEMATIC DIAGRAM	18
17. TUNER PC BOARD.....	19
18. SURROUND SCHEMATIC DIAGRAM	20
19. SURROUND PC BOARD	21
20. FRONT END SCHEMATIC DIAGRAM.....	22

μ PD4053BP

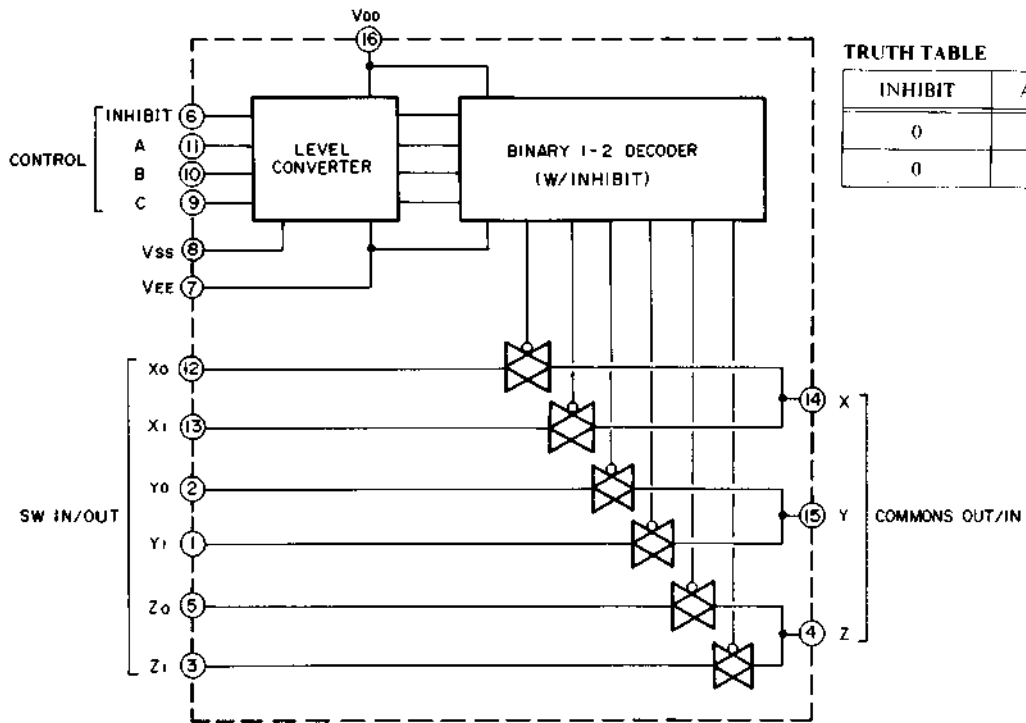

TRUTH TABLE

INHIBIT	A or B or C	"ON" CHANNEL
0	0	X ₀ or Y ₀ or Z ₀
0	1	X ₁ or Y ₁ or Z ₁

TC9153P

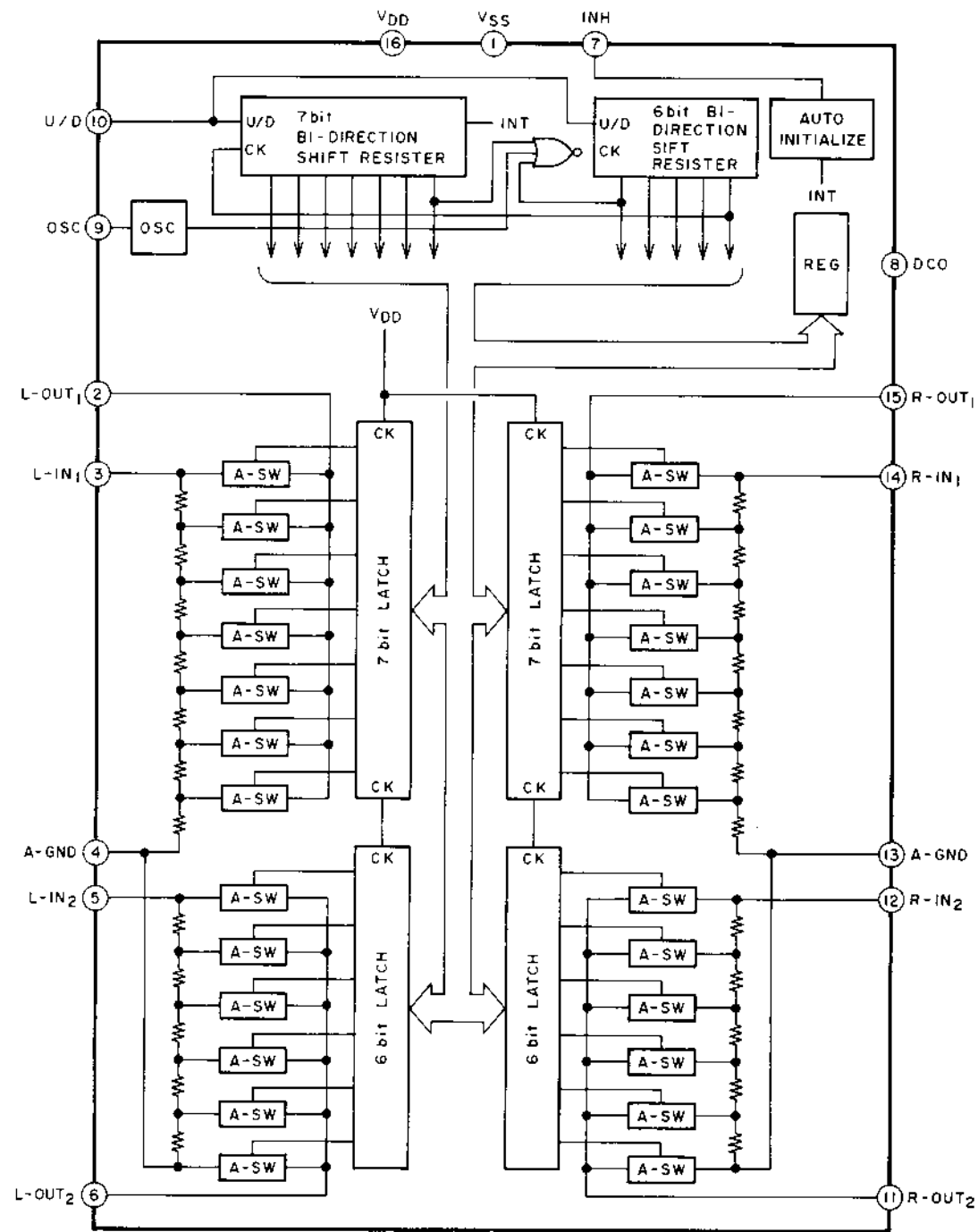

TC9155P

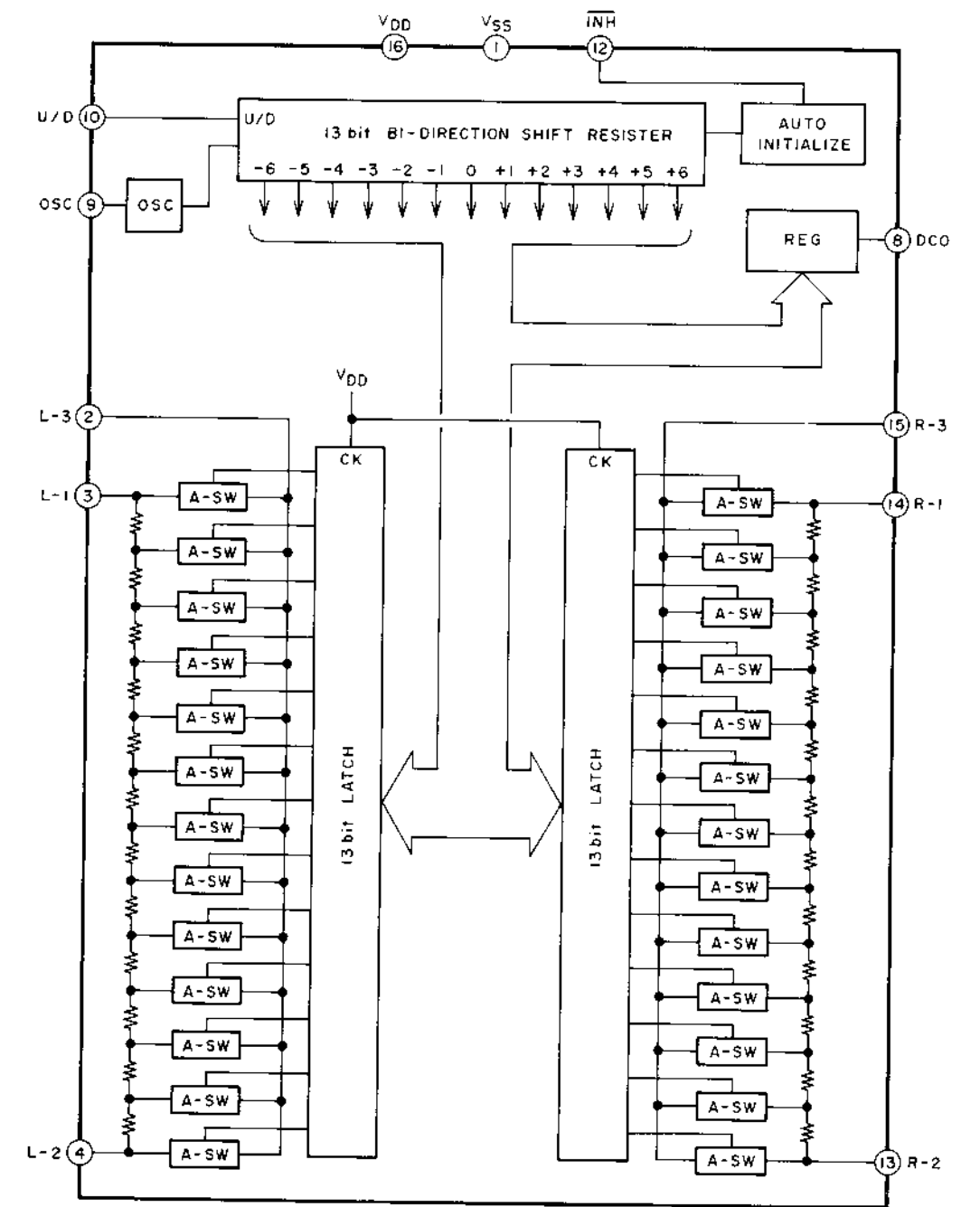

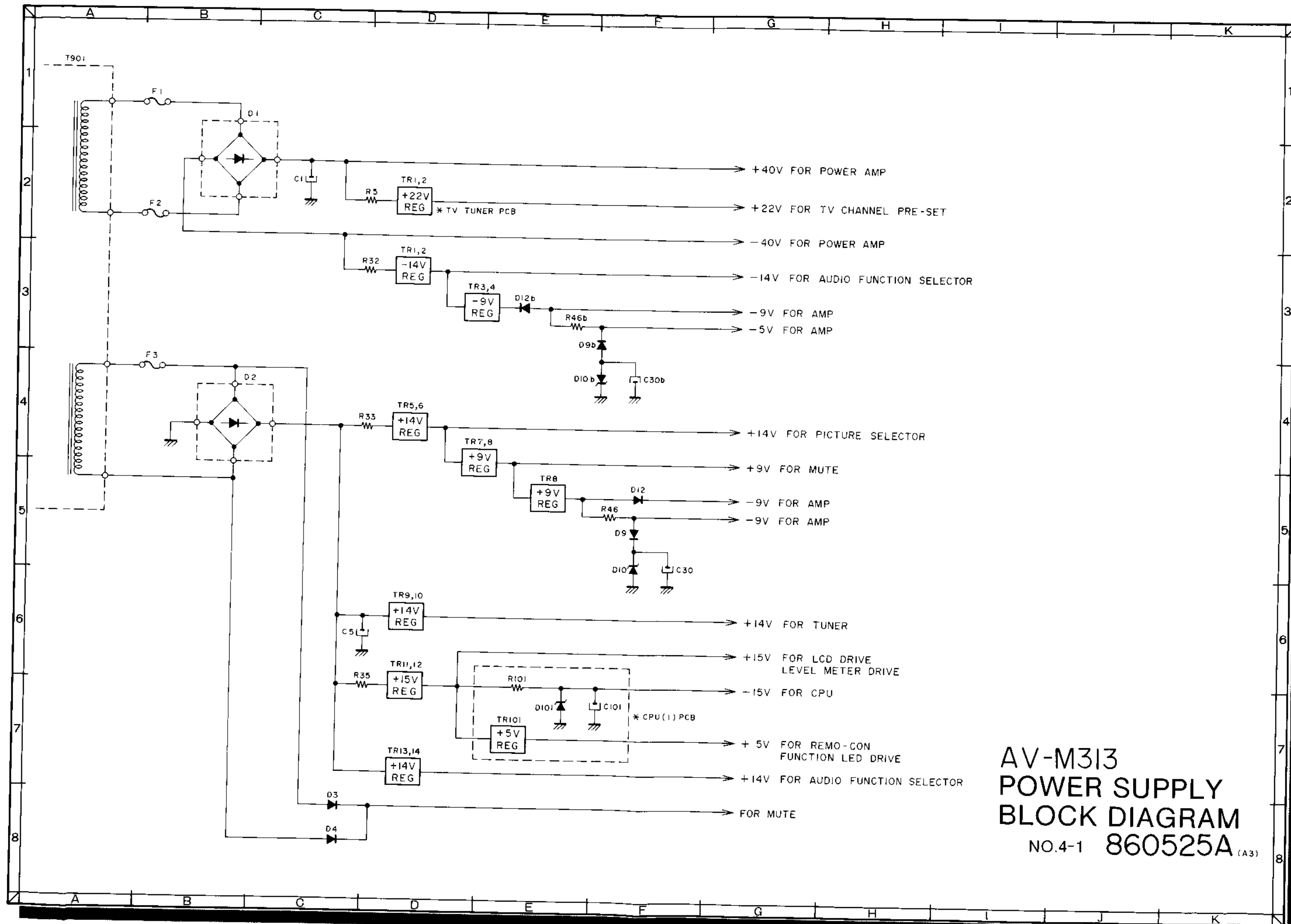

AV-M313
 POWER SUPPLY
 BLOCK DIAGRAM
 NO.4-1 860525A (A3)

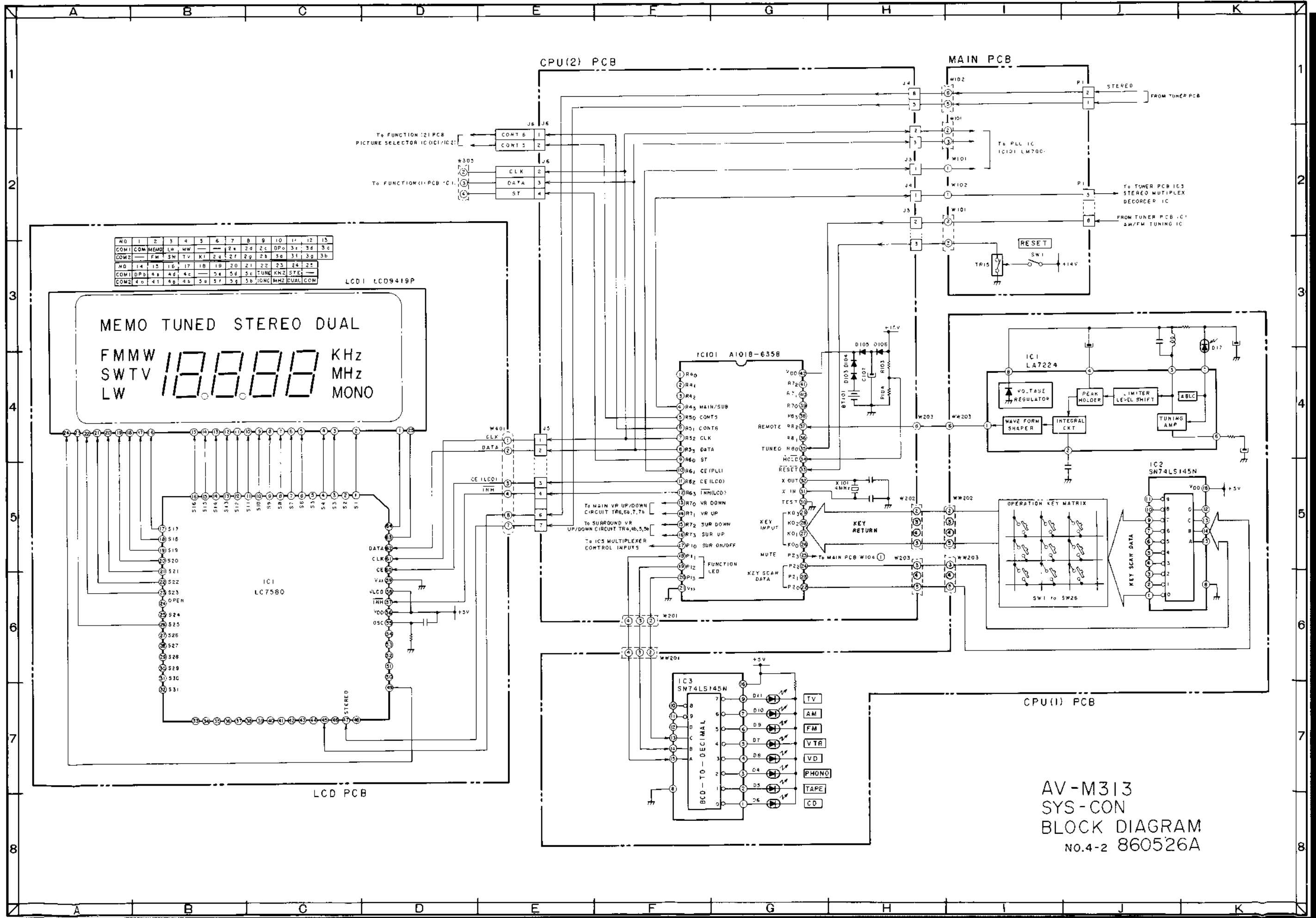

NO	1	2	3	4	5	6	7	8	9	10	11	12	13
COM1	COM	MEMO	LW	MW	—	24	26	2c	DP	31	34	3c	
COM2	—	FM	SW	TV	K1	2d	2f	2g	2h	30	31	3g	3b
NO	14	15	16	17	18	19	20	21	22	23	24	25	
COM1	DP	33	4c	—	34	34	3c	TUNE	KHZ	STEP	—		
COM2	4c	41	4g	4b	50	5f	5g	5b	10MC	MHZ	DUAL	COM	

MEMO TUNED STEREO DUAL
 FMMW SWTV 18888 KHz
 LW 18888 MHz
 MONO

IC1
LC7580

LCD PCB

CPU(2) PCB

MAIN PCB

CPU(1) PCB

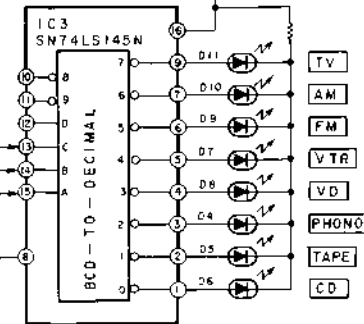

AV-M313
SYS-CON
BLOCK DIAGRAM
No.4-2 860526A

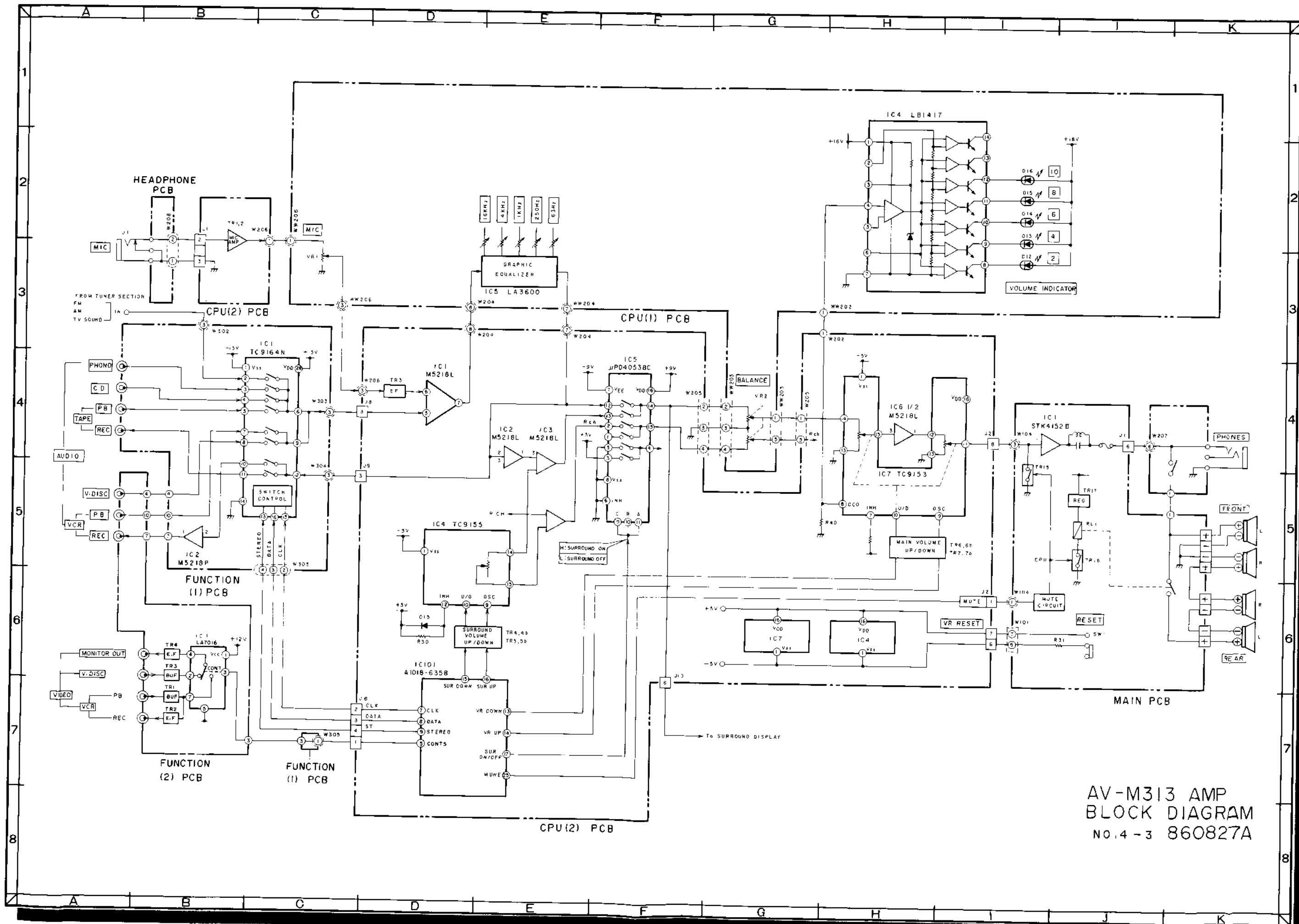

AV-M313 AMP
BLOCK DIAGRAM
No. 4-3 860827A

MAIN PCB

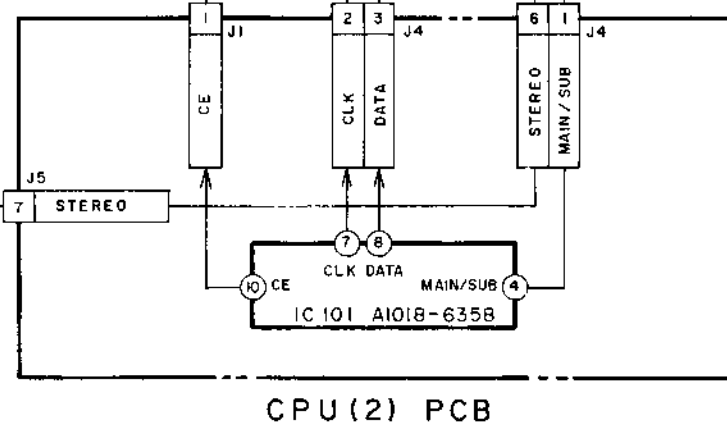
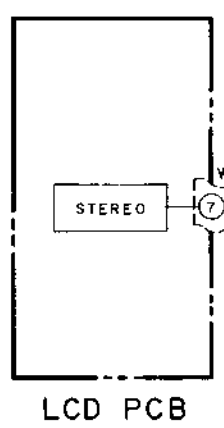
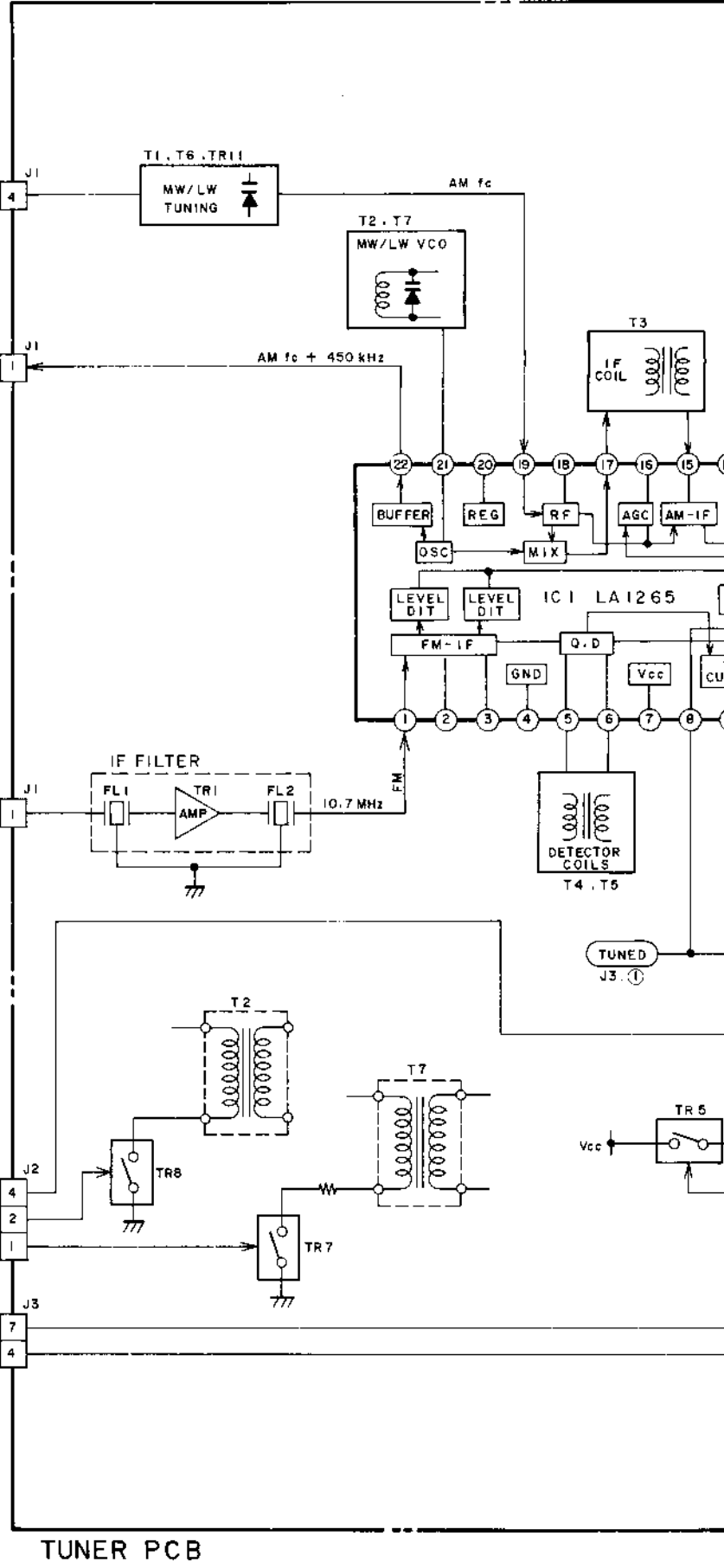
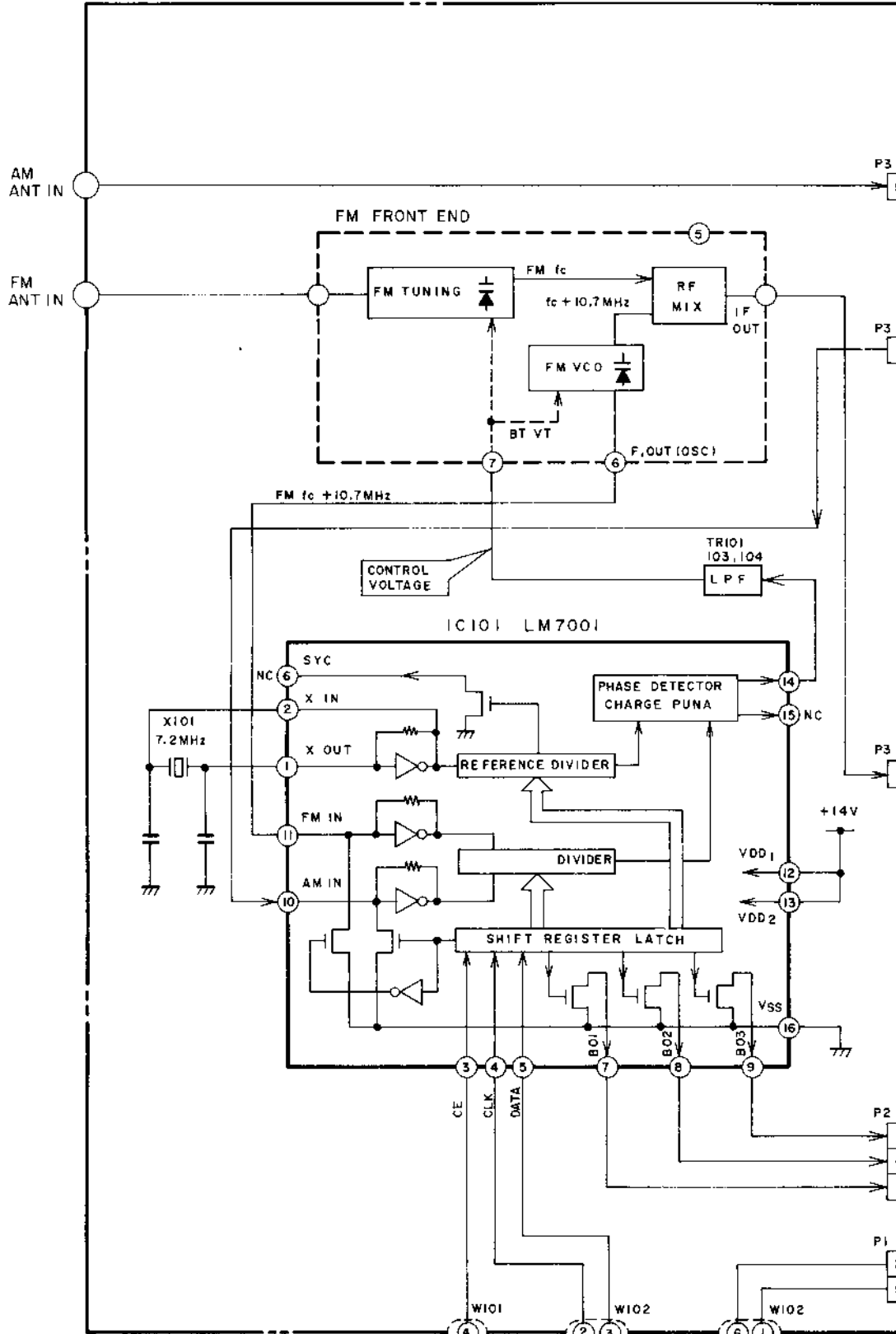

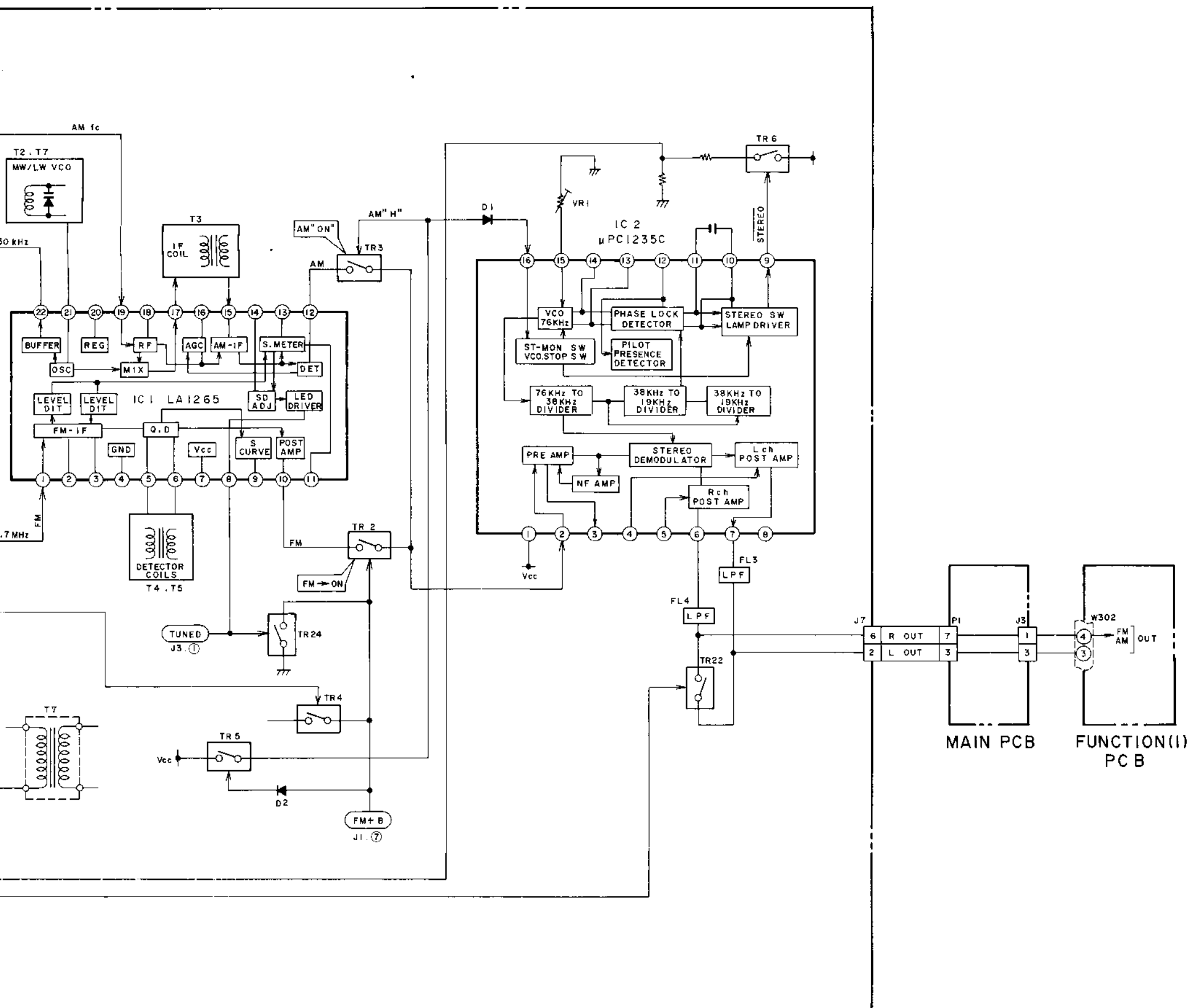

AV-M313 TUNER
 BLOCK DIAGRAM
 No. 4-4 861007A

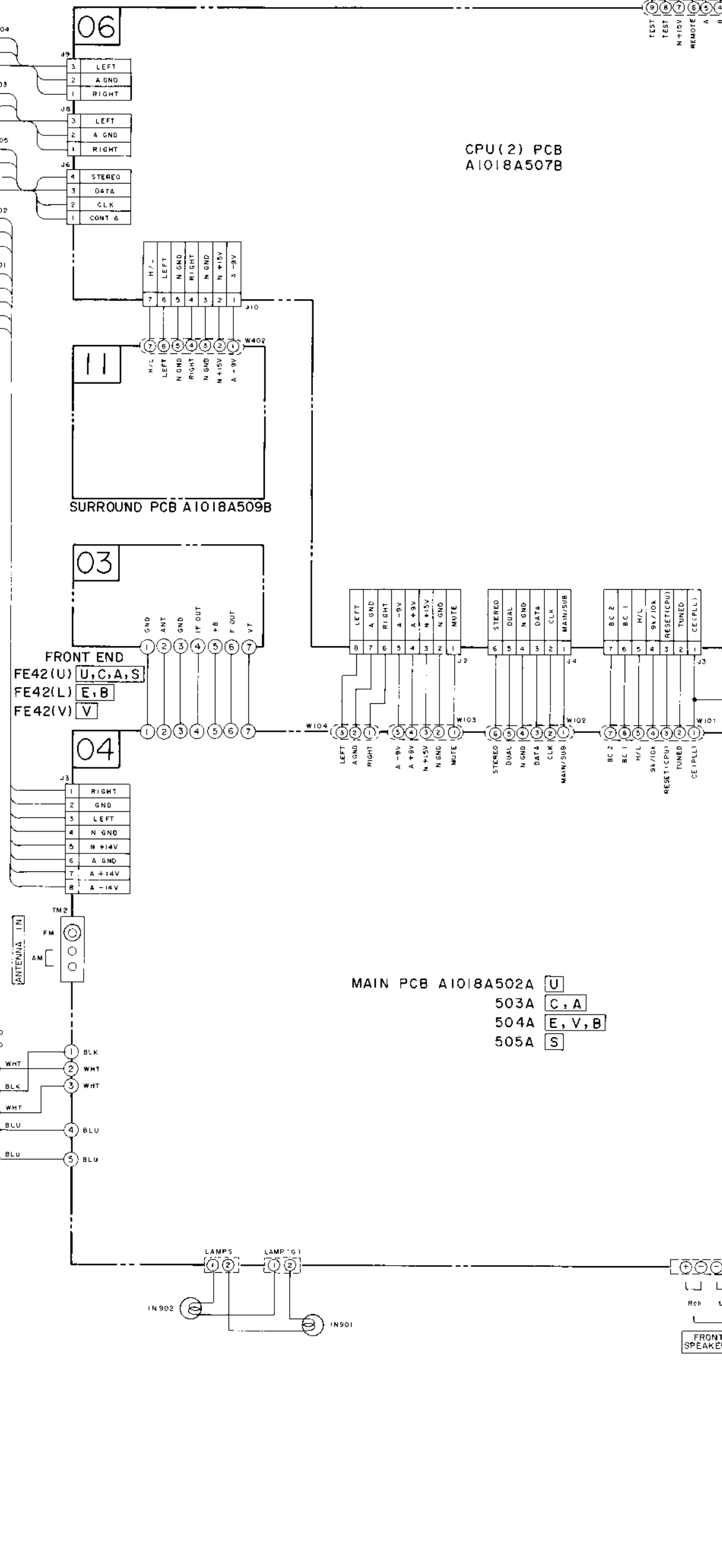
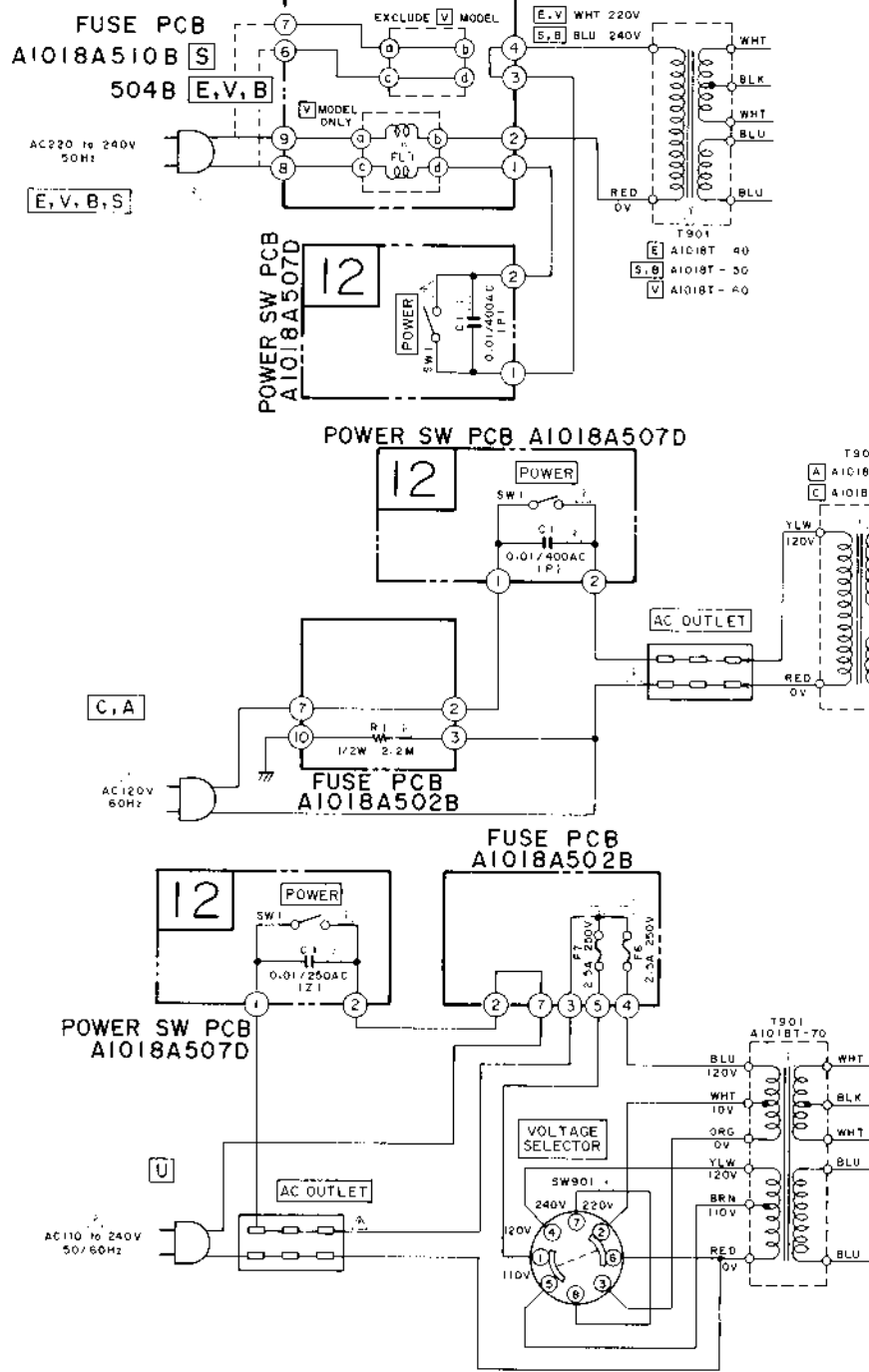
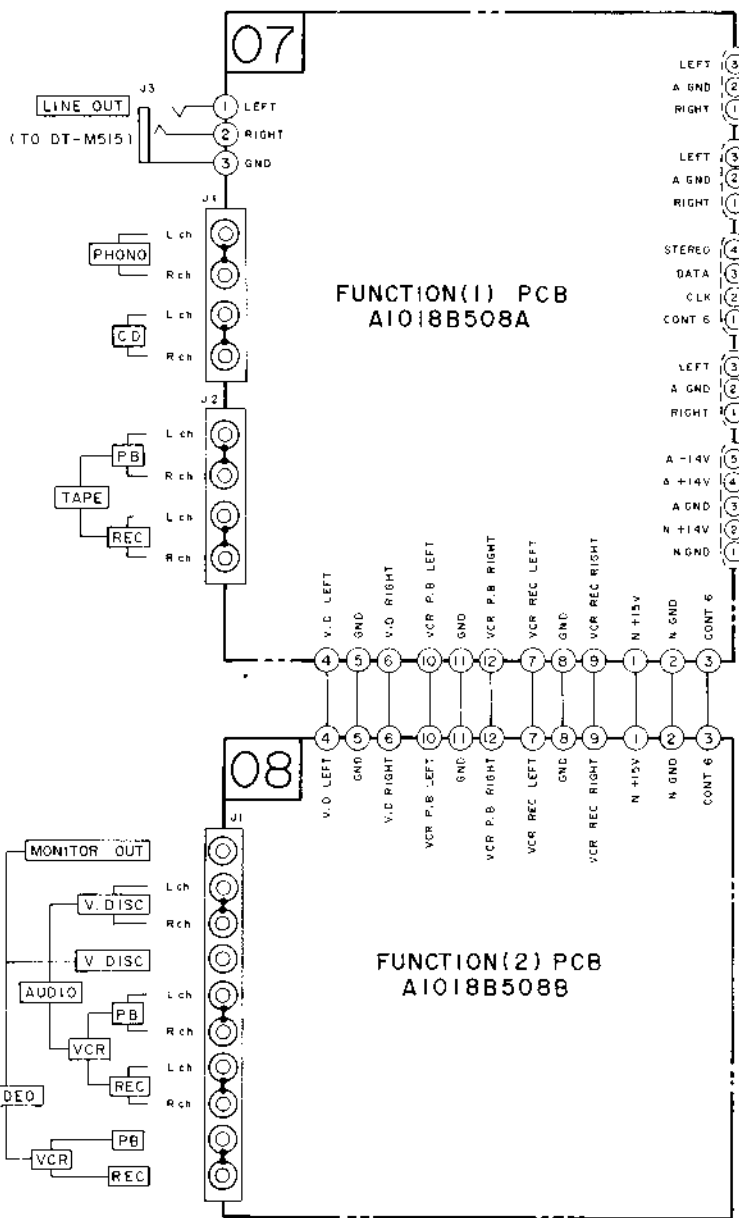

A B C D E F

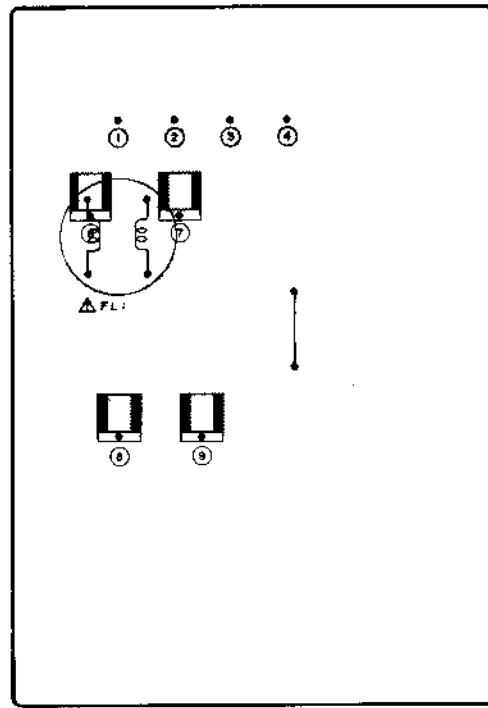

FUSE PCB AI018A504B E B V
510B S

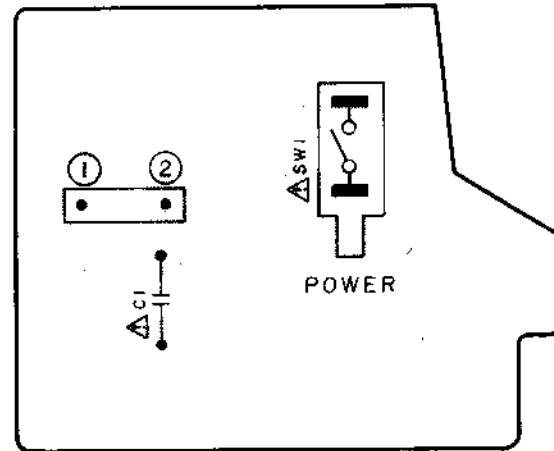

POWER SW PCB AI018A507D

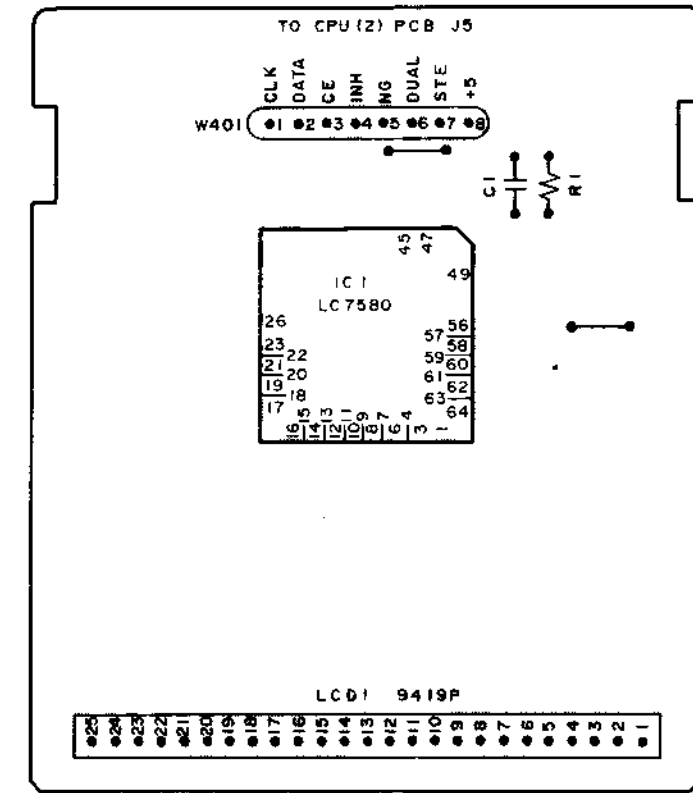

LCD PCB AI018A509A(-A)

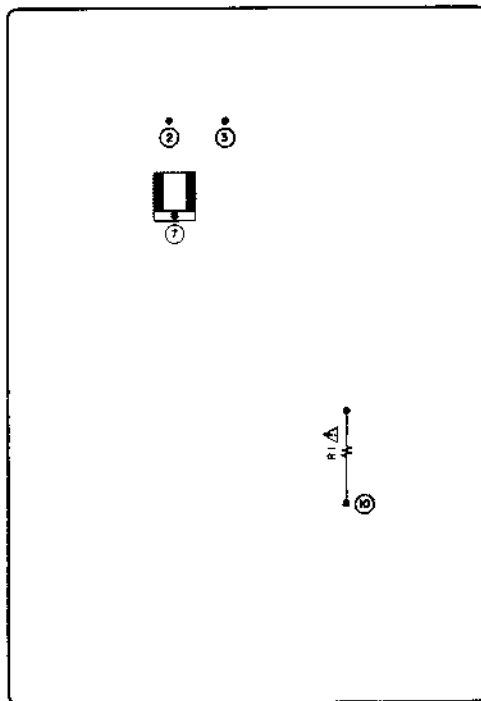

FUSE PCB AI018A503B C A

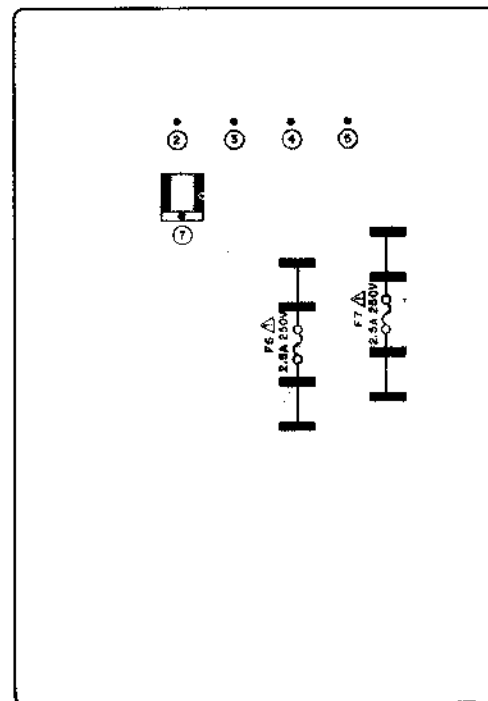

FUSE PCB AI018B502B U

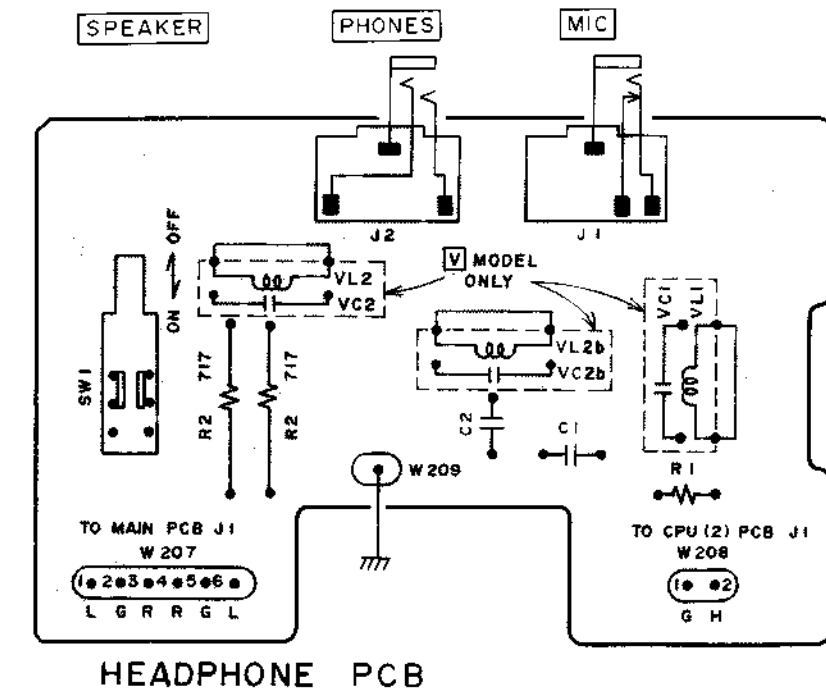

HEADPHONE PCB

WARNING Δ INDICATES SAFETY CRITICAL COMPONENTS. FOR CONTINUED SAFETY, REPLACE SAFETY CRITICAL COMPONENTS ONLY WITH MANUFACTURER'S RECOMMENDED PARTS.
AVERTISSEMENT Δ IL INDIQUE LES COMPOSANTS CRITIQUES DE SÉCURITÉ POUR MAINTENIR LE DEGRÉ DE SÉCURITÉ DE L'APPAREIL. NE REMPLACER QUE DES PIÈCES RECOMMANDÉES PAR LE FABRICANT.

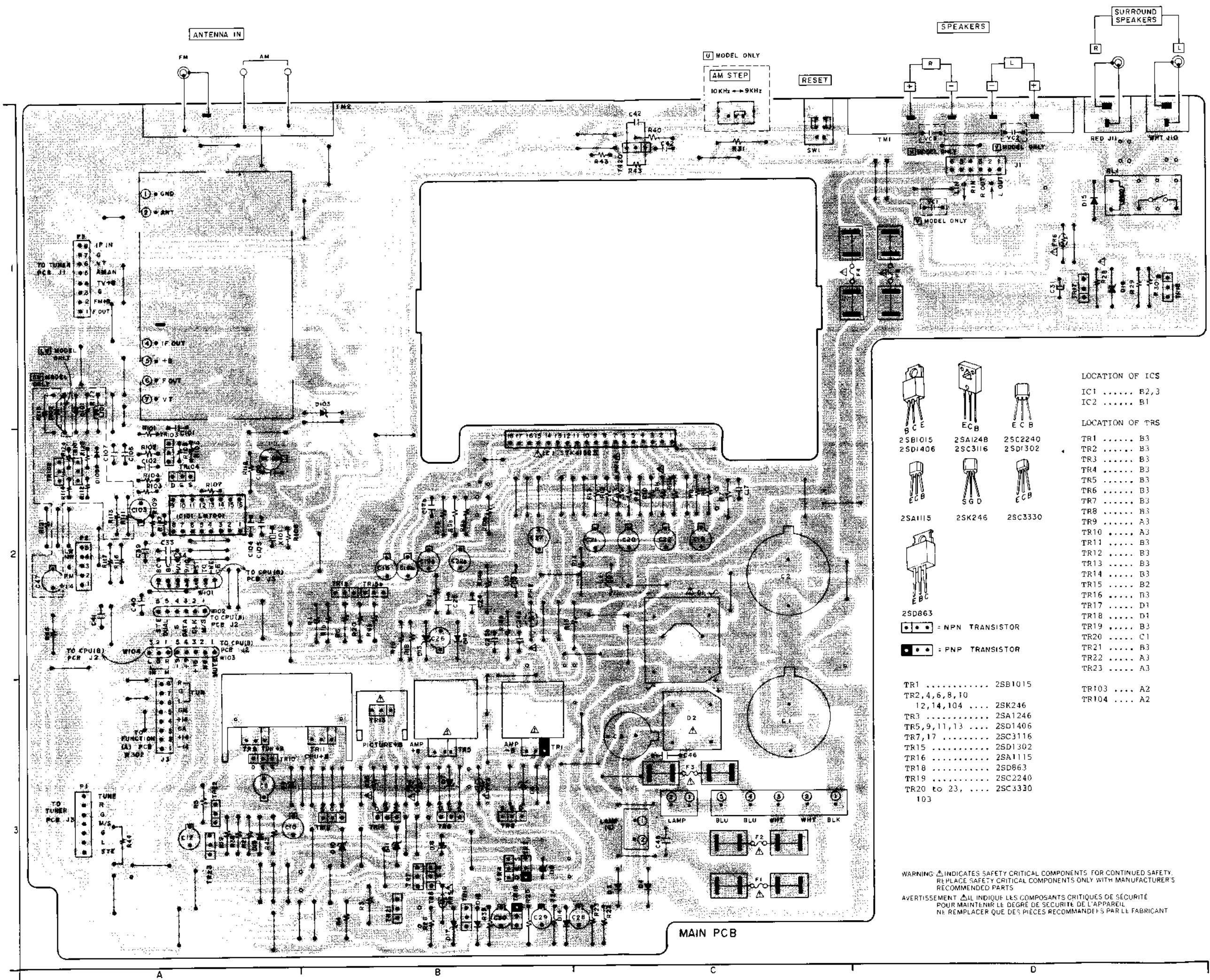

LOCATION OF ICs

IC1 B2,3
 IC2 B1

LOCATION OF TRs

			TR1 B3
2SB1015	2SA1248	2SC2240	TR2 B3
2SD1406	2SC3116	2SD1302	TR3 B3
			TR4 B3
2SA1115	2SK246	2SC3330	TR5 B3
			TR6 B3
2SD863			TR7 B3
			TR8 B3
			TR9 A3
			TR10 A3
			TR11 B3
			TR12 B3
			TR13 B3
			TR14 B3
			TR15 B2
			TR16 B3
			TR17 D1
			TR18 D1
			TR19 B3
			TR20 C1
			TR21 B3
			TR22 A3
			TR23 A3

TR1 2SB1015
 TR2,4,6,8,10 2SK246
 TR3 2SA1246
 TR5,9,11,13 2SD1406
 TR7,17 2SC3116
 TR15 2SD1302
 TR18 2SA1115
 TR19 2SD863
 TR20 to 23 2SC3330
 103

WARNING: INDICATES SAFETY CRITICAL COMPONENTS. FOR CONTINUED SAFETY, REPLACE SAFETY CRITICAL COMPONENTS ONLY WITH MANUFACTURER'S RECOMMENDED PARTS.

AVERTISSEMENT: IL INDIQUE LES COMPOSANTS CRITIQUES DE SECURITE. POUR MAINTENIR LE DEGRE DE SECURITE DE L'APPAREIL, NE REMPLACER QUE DES PIECES RECOMMANDEES PAR LE FABRICANT.

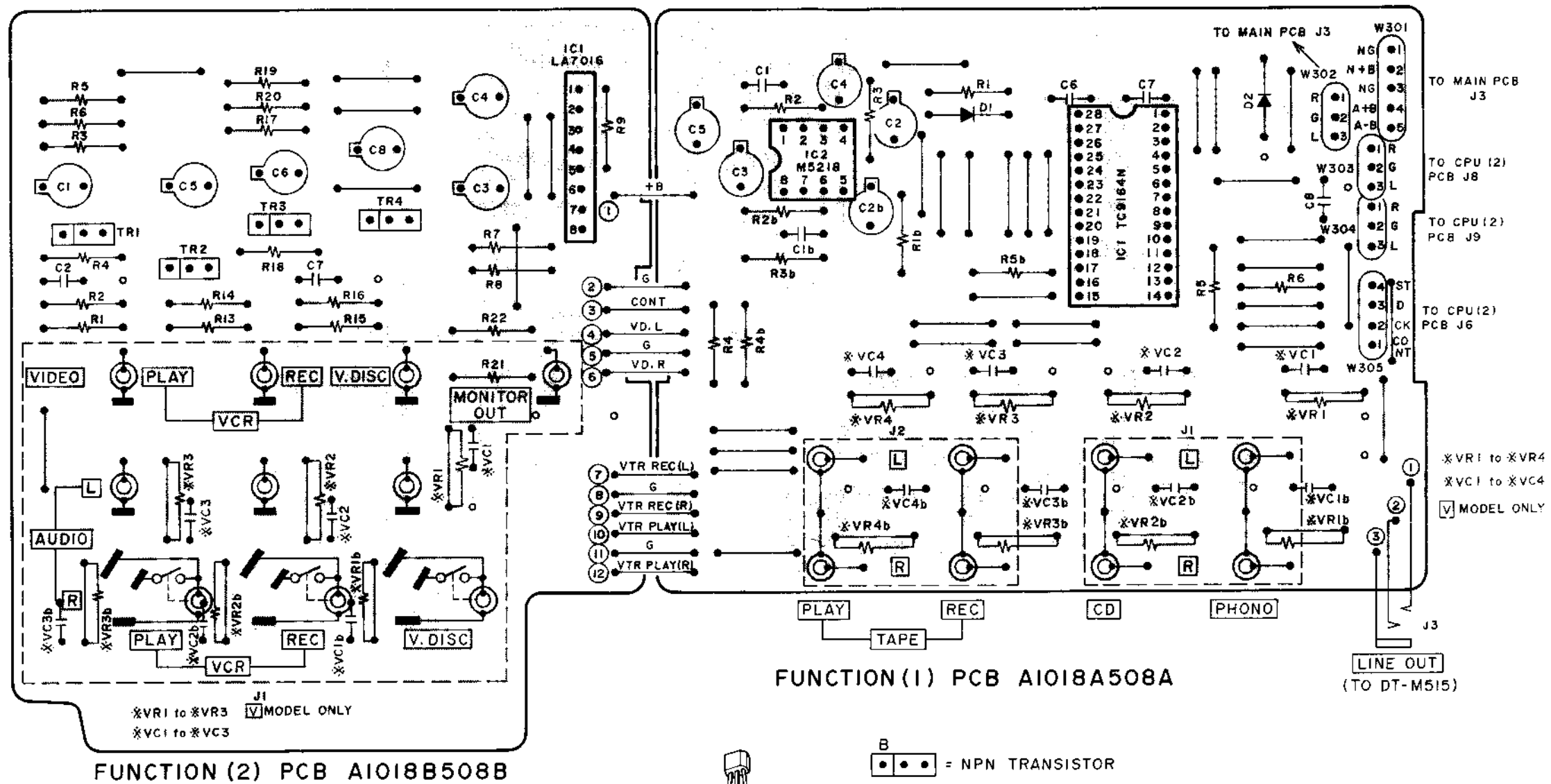

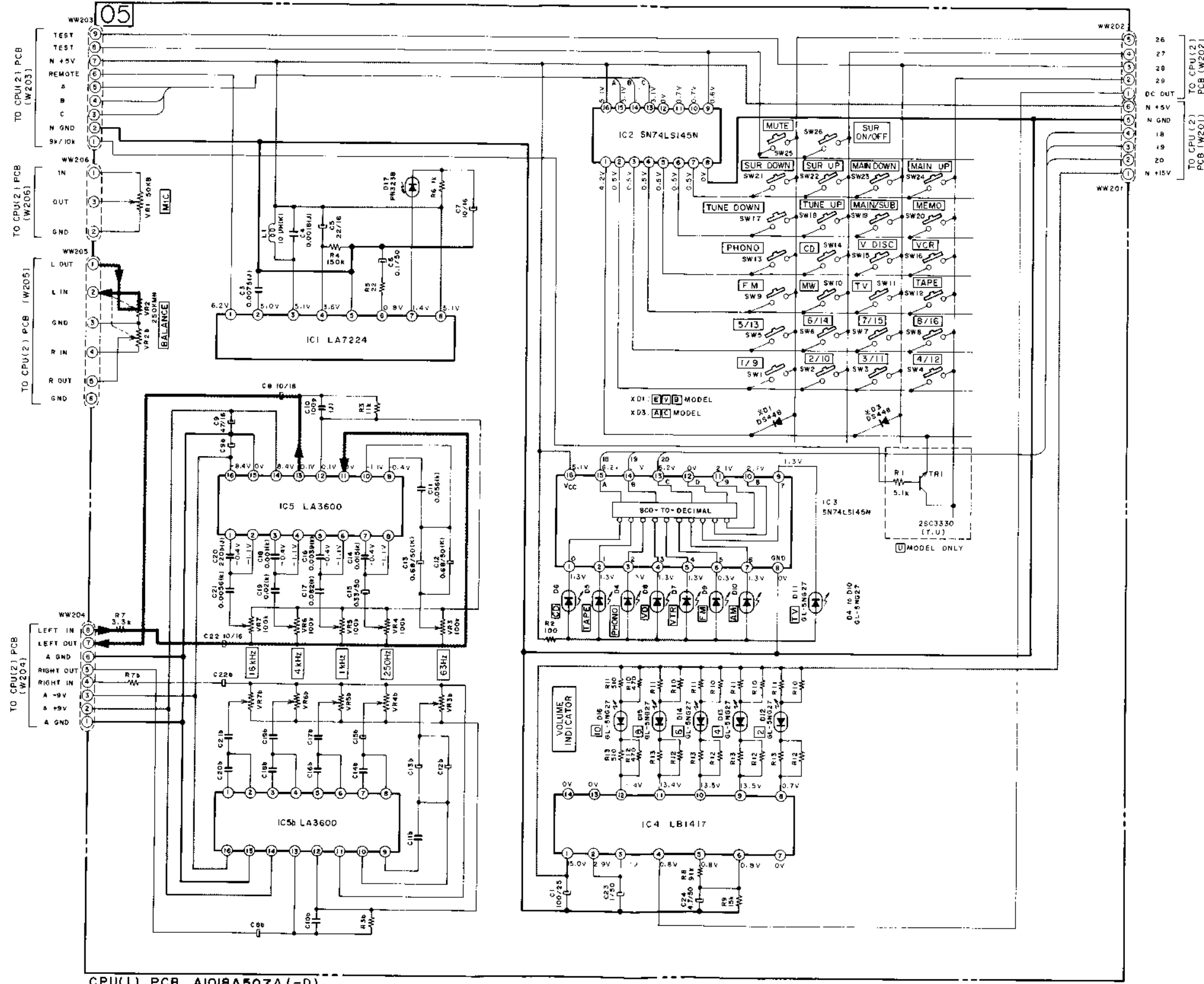

CPU(1) PCB A1018A507A (-D)

— B (POWER SUPPLY) LINE
 ——— SIGNAL LINE

NOTE
 UNLESS OTHERWISE SPECIFIED
 ALL RESISTORS IN OHMS 1/4W(J)
 ALL CAPACITORS IN μ F 50WV(J)

AV-M313 CPU(1)
 SCHEMATIC DIAGRAM
 NO. 8-4 860533 B (A2)

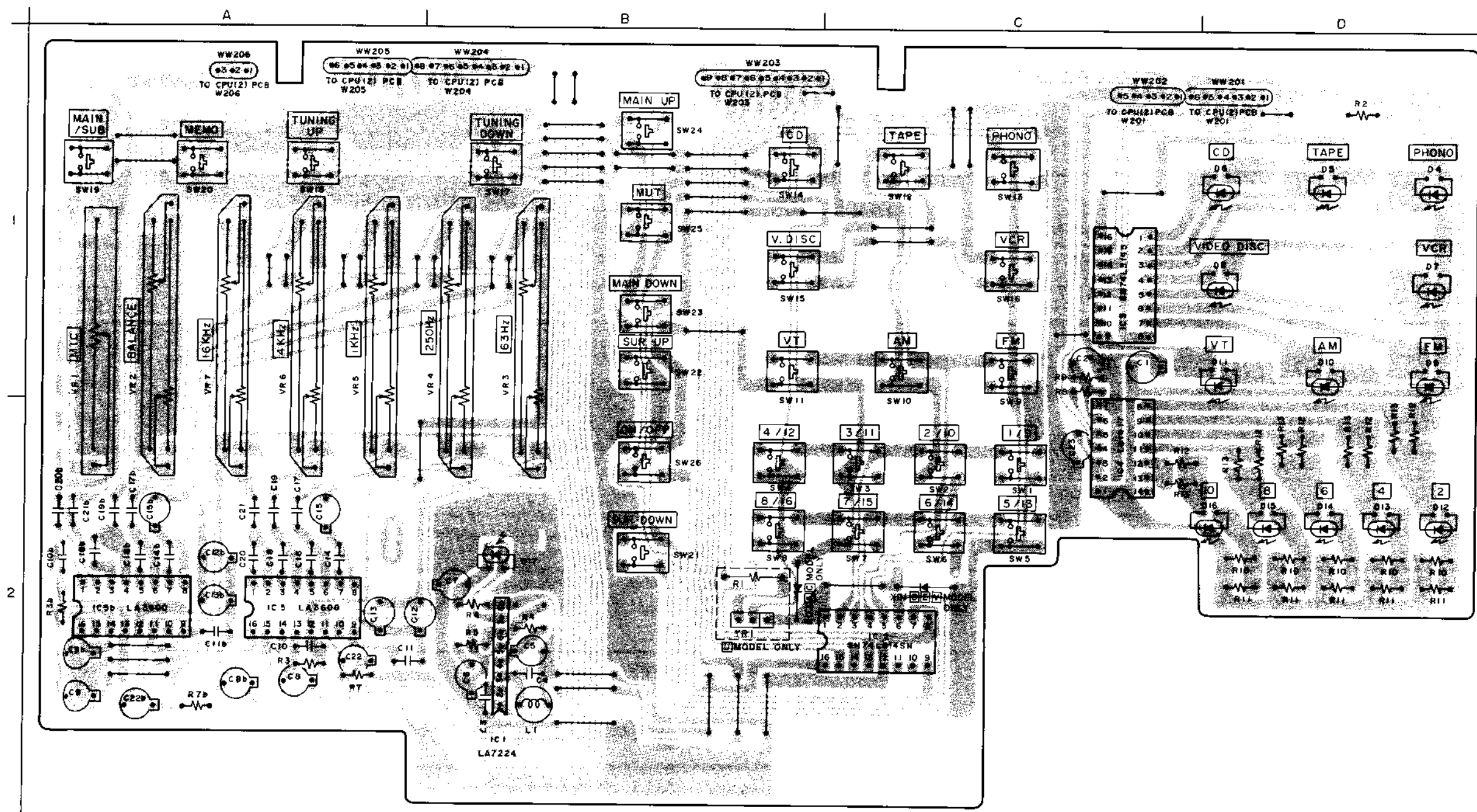

LOCATION OF ICs
 IC 1-----B2
 IC 2-----C2
 IC 3-----C1
 IC 4-----C2
 IC 5-----A2

CPU(1) PCB A1018A507A(-D)

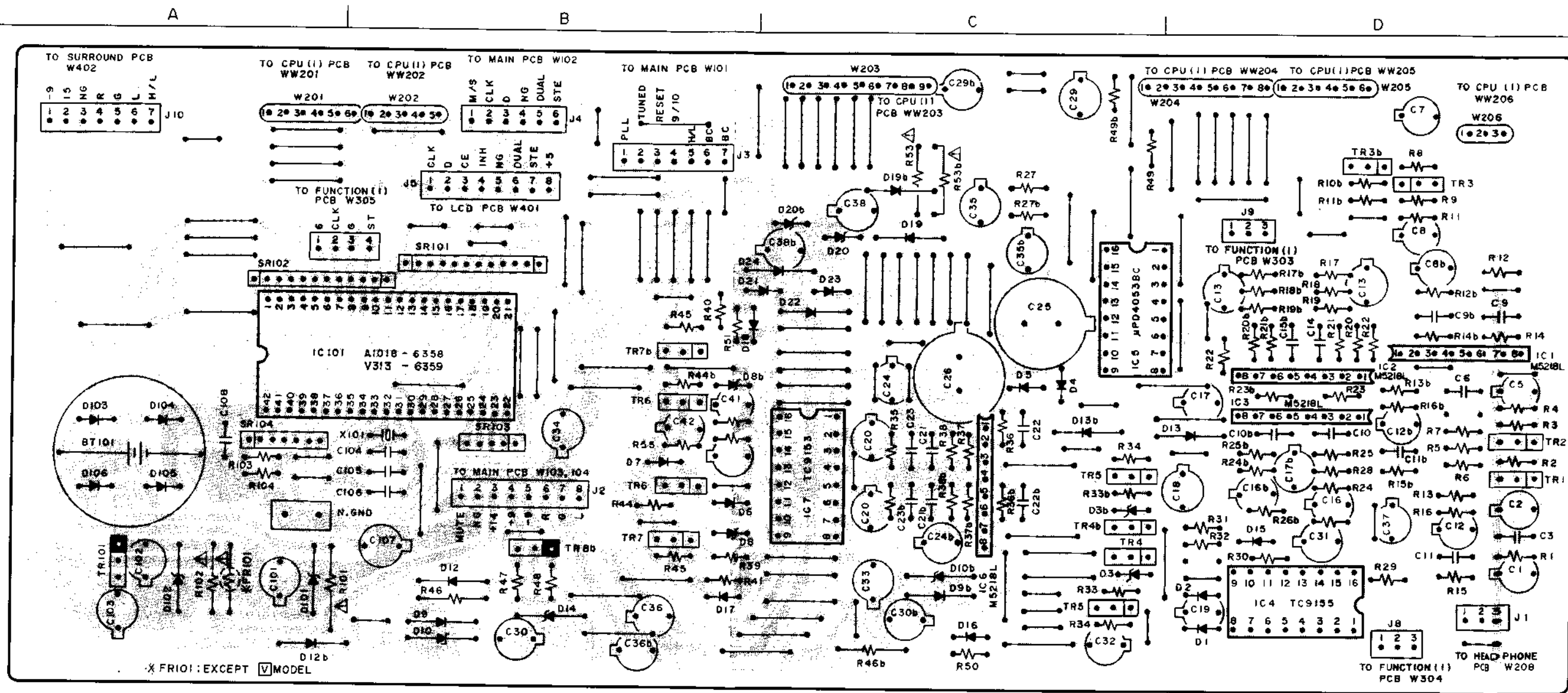

CPU(2) PCB A1018A507B

LOCATION OF TRs	LOCATION OF TRs
IC 1 ----- A2	TR 1 ----- A1
IC 2 ----- A1	TR 2 ----- A1
IC 3 ----- A1	TR 3 ----- A2
IC 4 ----- A1	TR 4 ----- B1
IC 5 ----- B2	TR 5 ----- B1
IC 6 ----- B1	TR 6 ----- C1
IC 7 ----- B1	TR 7 ----- C1
IC 101----- C1,C2	TR 8 ----- C1
	TR 101----- A2

- TR 1,2,3-----2SC3383
- TR 4,6-----RNI205
- TR 5,7-----2SC3330
- TR 8-----2SA1392
- TR 101-----2SD571

B
 : PNP TRANSISTOR
 : NPN TRANSISTOR

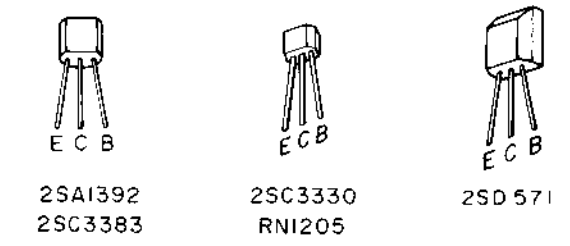

WARNING: INDICATES SAFETY CRITICAL COMPONENTS. FOR CONTINUED SAFETY, REPLACE SAFETY CRITICAL COMPONENTS ONLY WITH MANUFACTURER'S RECOMMENDED PARTS.

AVERTISSEMENT: IL INDIQUE LES COMPOSANTS CRITIQUES DE SÉCURITÉ. POUR MAINTENIR LE DEGRÉ DE SÉCURITÉ DE L'APPAREIL, NE REMPLACER QUE DES PIÈCES RECOMMANDÉES PAR LE FABRICANT.

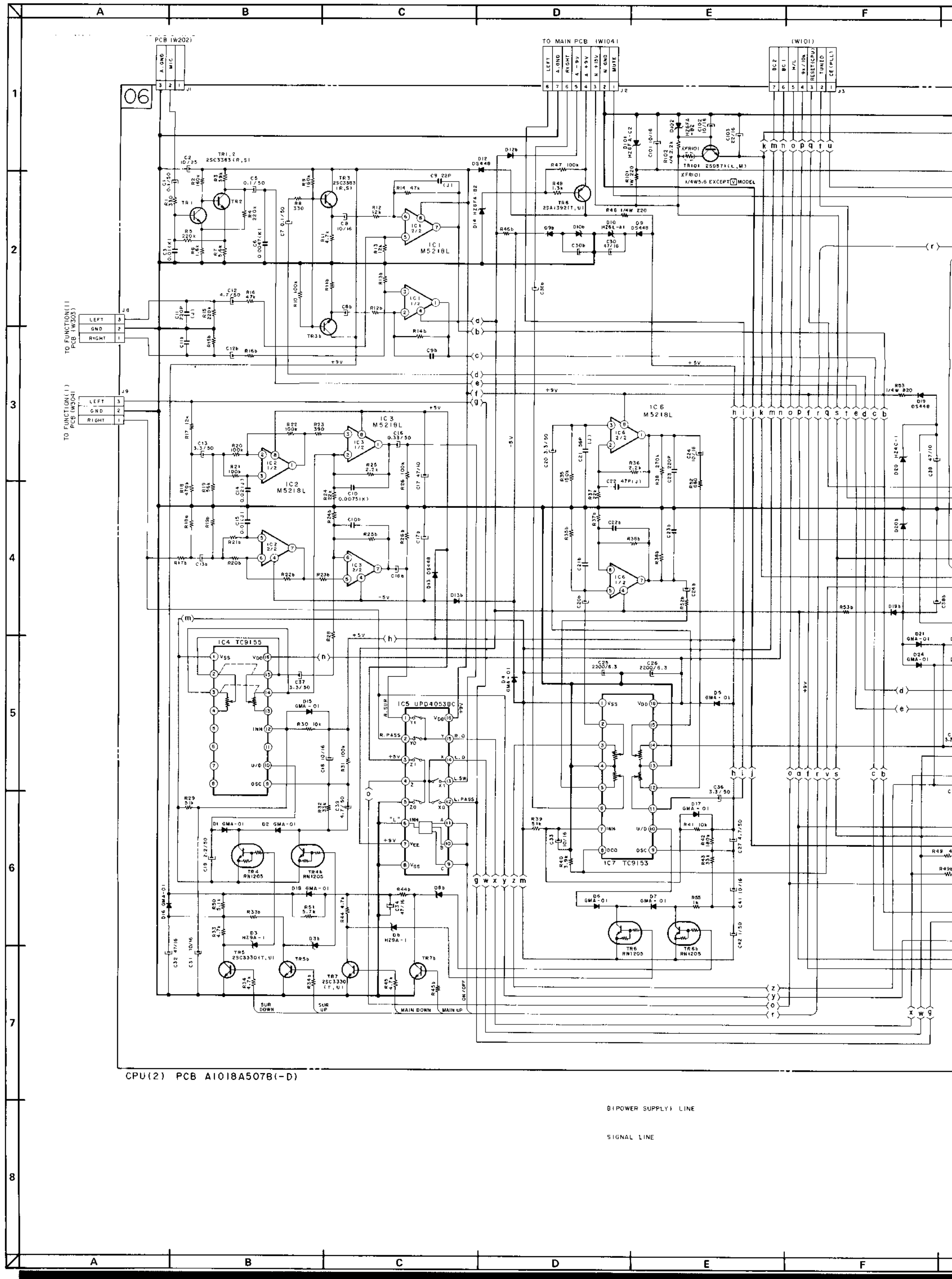

CPU(2) PCB AI018A507B(-D)

BIPOWER SUPPLY LINE

SIGNAL LINE

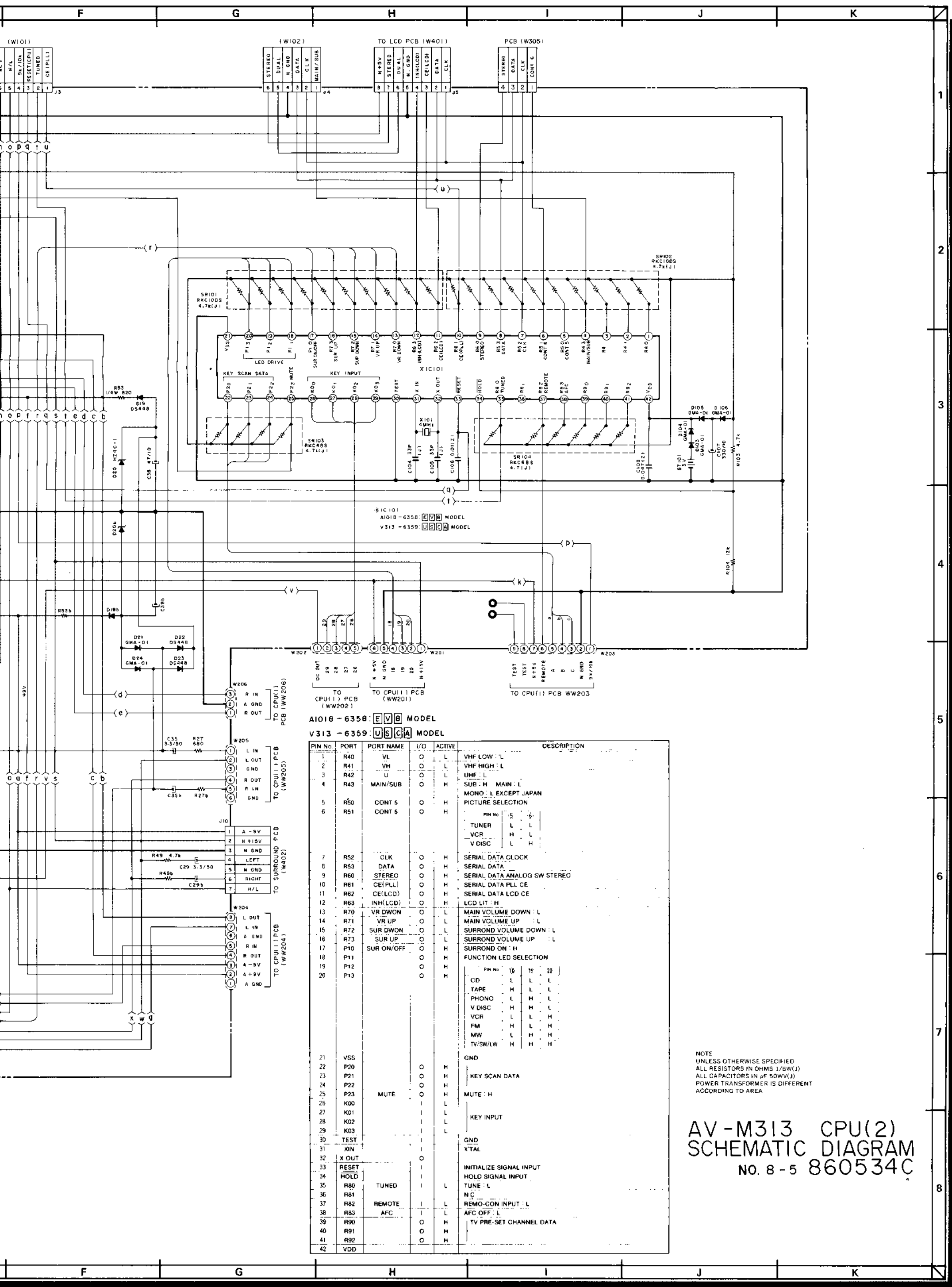

A1018 - 6358: **EVB** MODEL
V313 - 6359: **USCA** MODEL

PIN No.	PORT	PORT NAME	I/O	ACTIVE	DESCRIPTION
1	R40	VL	O	L	VHF LOW : L
2	R41	VH	O	L	VHF HIGH : L
3	R42	U	O	L	UHF
4	R43	MAIN/SUB	O	H	SUB : H MAIN : L MONO : L EXCEPT JAPAN PICTURE SELECTION
5	R50	CONT 5	O	H	PIN No. 5 6 TUNER L L VCR H L V DISC L H
6	R51	CONT 6	O	H	
7	R52	CLK	O	H	SERIAL DATA CLOCK
8	R53	DATA	O	H	SERIAL DATA
9	R60	STEREO	O	H	SERIAL DATA ANALOG SW STEREO
10	R61	CE(PLL)	O	H	SERIAL DATA PLL CE
11	R62	CE(LCD)	O	H	SERIAL DATA LCD CE
12	R63	INH(LCD)	O	H	LCD LIT : H
13	R70	VR DWON	O	L	MAIN VOLUME DOWN : L
14	R71	VR UP	O	L	MAIN VOLUME UP : L
15	R72	SUR DWON	O	L	SURROUND VOLUME DOWN : L
16	R73	SUR UP	O	L	SURROUND VOLUME UP : L
17	P10	SUR ON/OFF	O	H	SURROUND ON : H
18	P11		O	H	FUNCTION LED SELECTION PIN No. 16 17 20 CD L L L TAPE H L L PHONO L H L V DISC H H L VCR L L H FM H L H MW L H H TV/SW/LW H H H
19	P12		O	H	
20	P13		O	H	
21	VSS				
22	P20		O	H	KEY SCAN DATA
23	P21		O	H	
24	P22		O	H	
25	P23	MUTE	O	H	MUTE : H
26	K00				KEY INPUT
27	K01				
28	K02				
29	K03				
30	TEST				GND
31	XIN				X'TAL
32	X OUT				
33	RESET				INITIALIZE SIGNAL INPUT
34	HOLD				HOLD SIGNAL INPUT
35	R80	TUNED	I	L	TUNE : L
36	R81				N C
37	R82	REMOTE	I	L	REMO-CON INPUT : L
38	R83	AFC	I	L	AFC OFF : L
39	R90		O	H	TV PRE-SET CHANNEL DATA
40	R91		O	H	
41	R92		O	H	
42	VDD				

NOTE
UNLESS OTHERWISE SPECIFIED
ALL RESISTORS IN OHMS 1/6W(J)
ALL CAPACITORS IN μ F 50WV(J)
POWER TRANSFORMER IS DIFFERENT
ACCORDING TO AREA

AV-M313 CPU(2)
SCHEMATIC DIAGRAM
No. 8-5 860534C

1
2
3
4
5
6
7
8

02

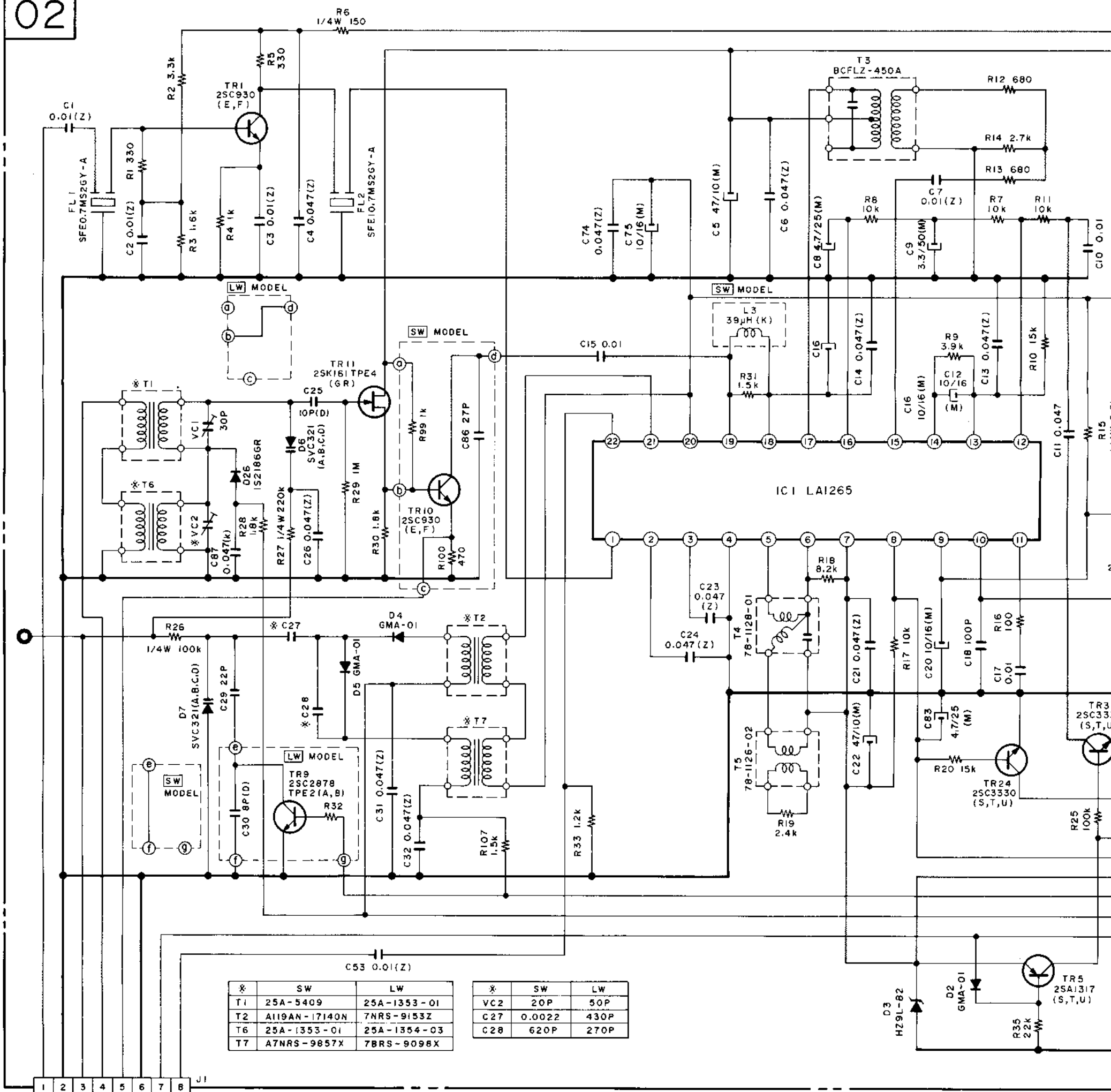

*	SW	LW
T1	25A-5409	25A-1353-01
T2	A119AN-17140N	7NRS-9153Z
T6	25A-1353-01	25A-1354-03
T7	A7NRS-9657X	7BRS-9098X

*	SW	LW
VC2	20P	50P
C27	0.0022	430P
C28	620P	270P

TUNER PCB A1018B5051

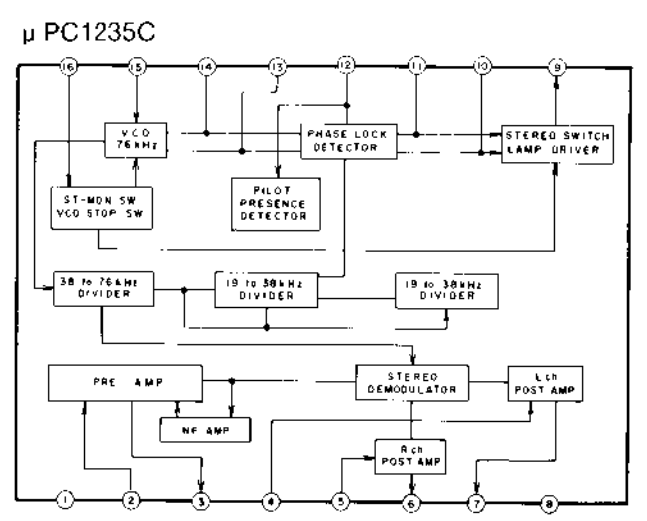
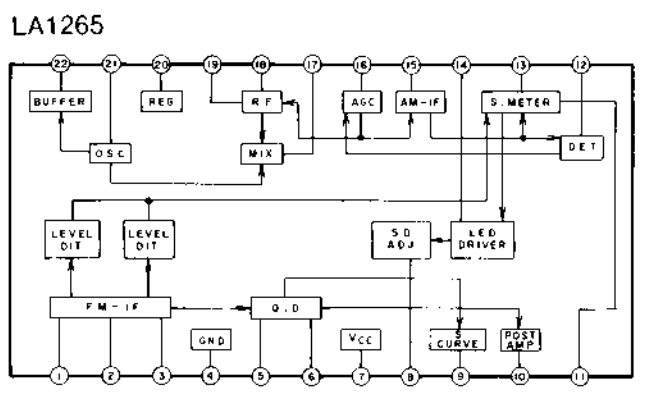
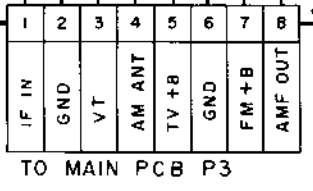

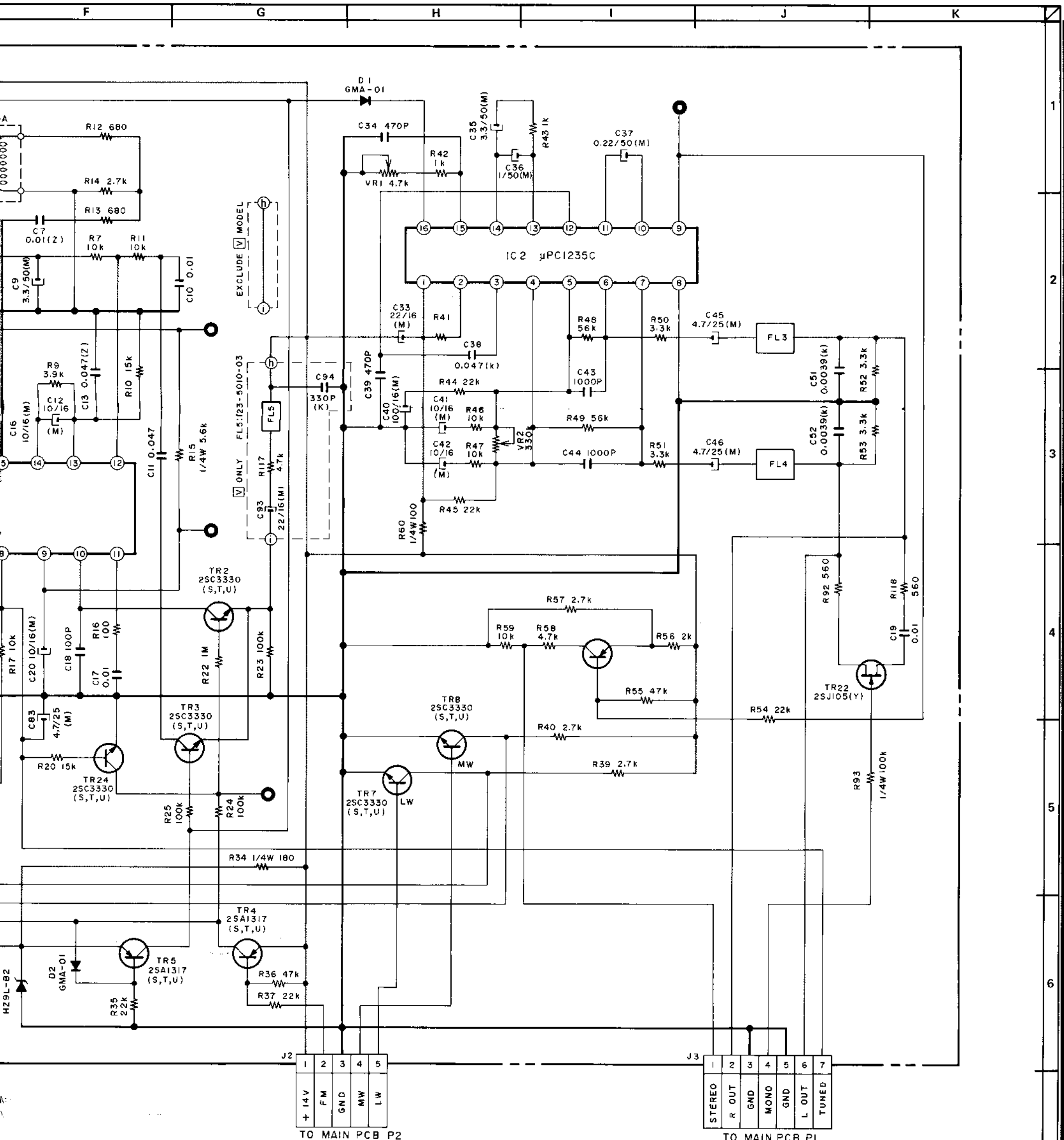

NOTE
 UNLESS OTHERWISE SPECIFIED
 ALL RESISTORS IN OHMS 1/6W(J)
 ALL CAPACITORS IN µF 50WV(J)
 POWER TRANSFORMER IS DIFFERENT
 ACCORDING TO AREA

B (POWER SUPPLY) LINE
 SIGNAL LINE

AV-M313S/L TUNER SCHEMATIC DIAGRAM NO.8-6 861008A

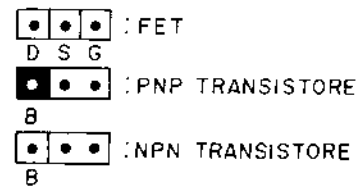
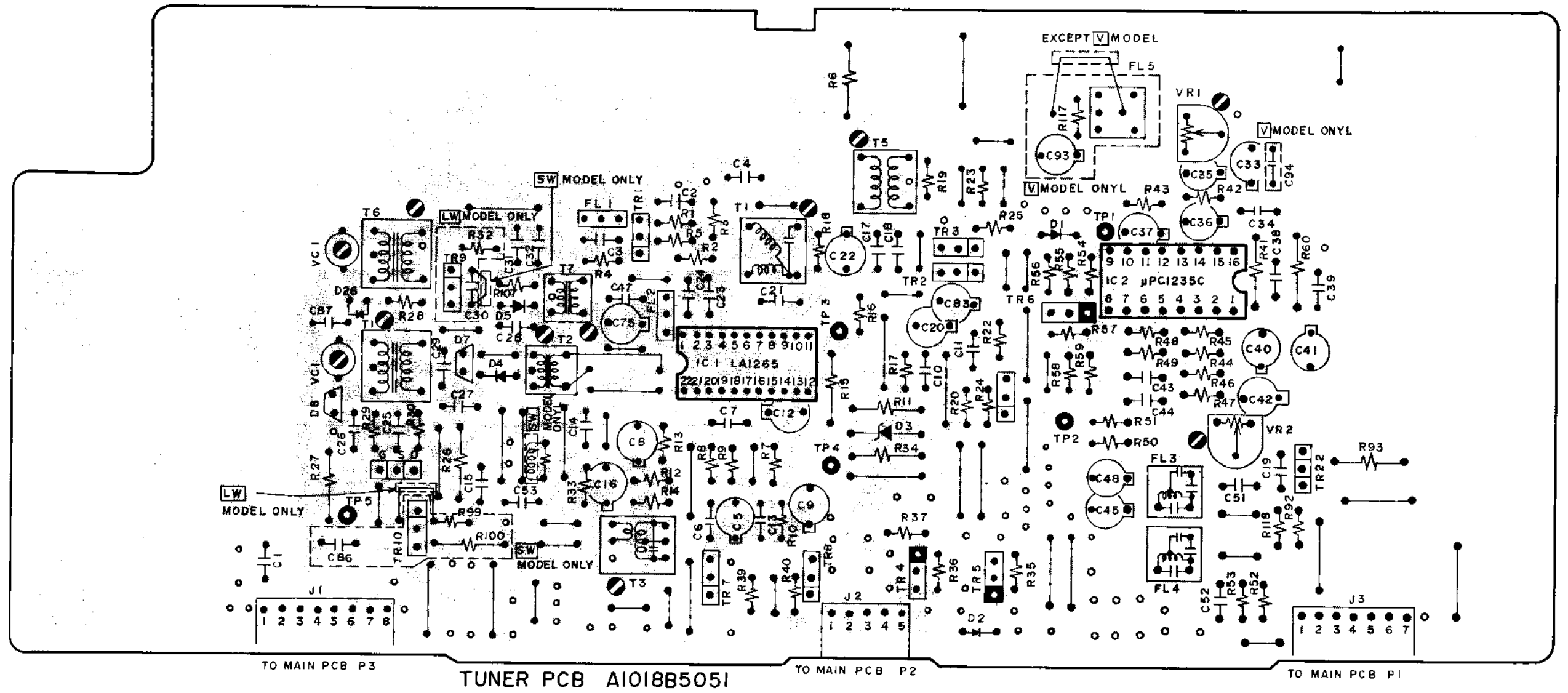

- 2SA1317 --- TR4, TR5, TR6
- 2SC930 --- TR1, TR10
- 2SC3330 --- TR2, TR3, TR7, TR8, TR24
- 2SC2878 --- TR9
- 2SJ105 --- TR22
- 2SK161 --- TR11

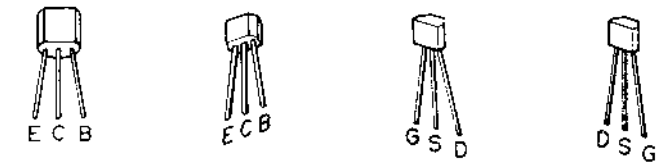

- 2SC930
- 2SC3330
- 2SJ105
- 2SK161
- 2SC2878
- 2SA1317

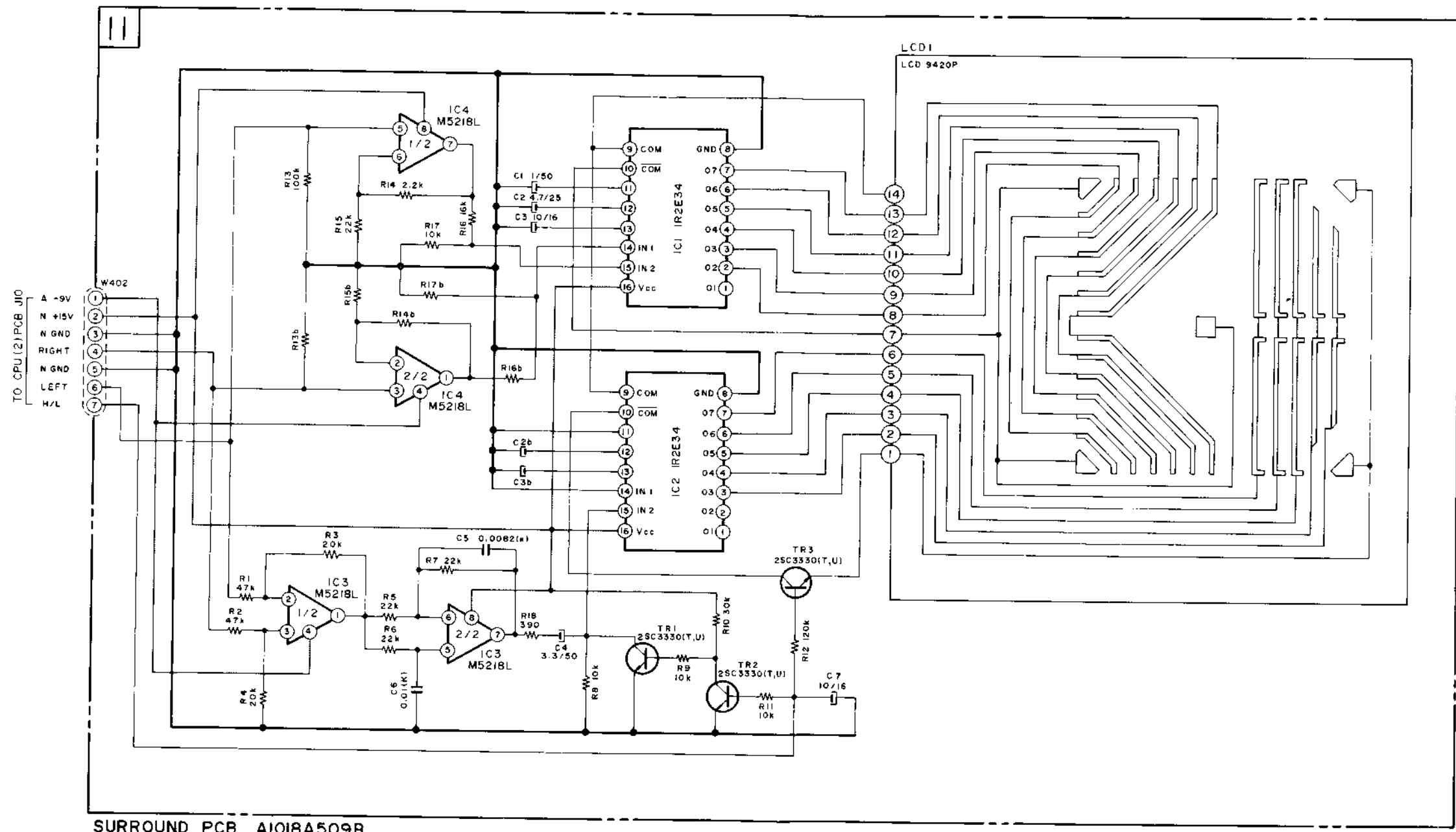

SURROUND PCB A1018A509B

: B (POWER SUPPLY) LINE

NOTE
 UNLESS OTHERWISE SPECIFIED
 ALL RESISTORS IN OHMS 1/6W(J)
 ALL CAPACITORS IN μF 50WV(J)

AV-M313SURROUND
 SCHEMATIC DIAGRAM
 NO.10-7 860536A

IR2E34

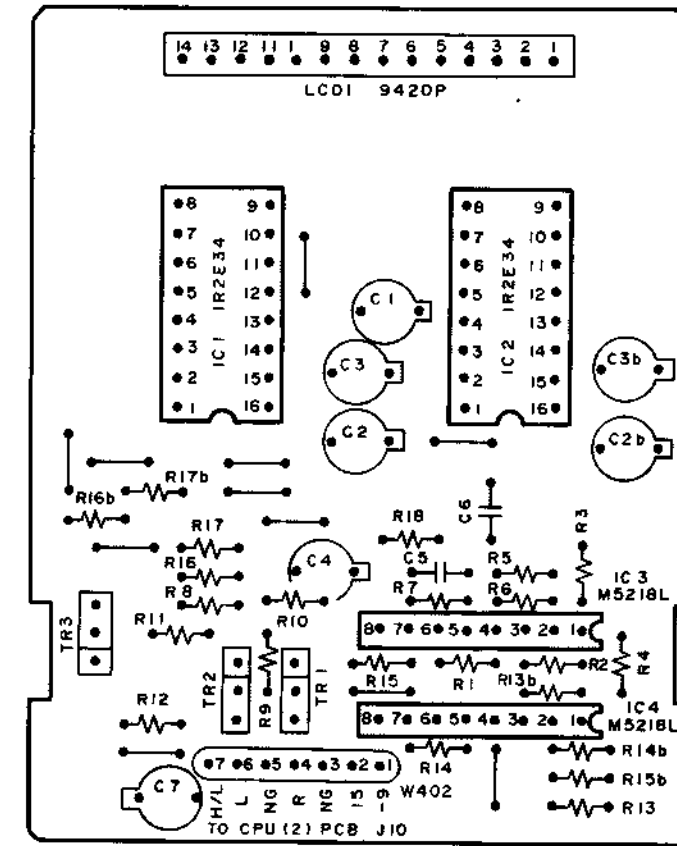
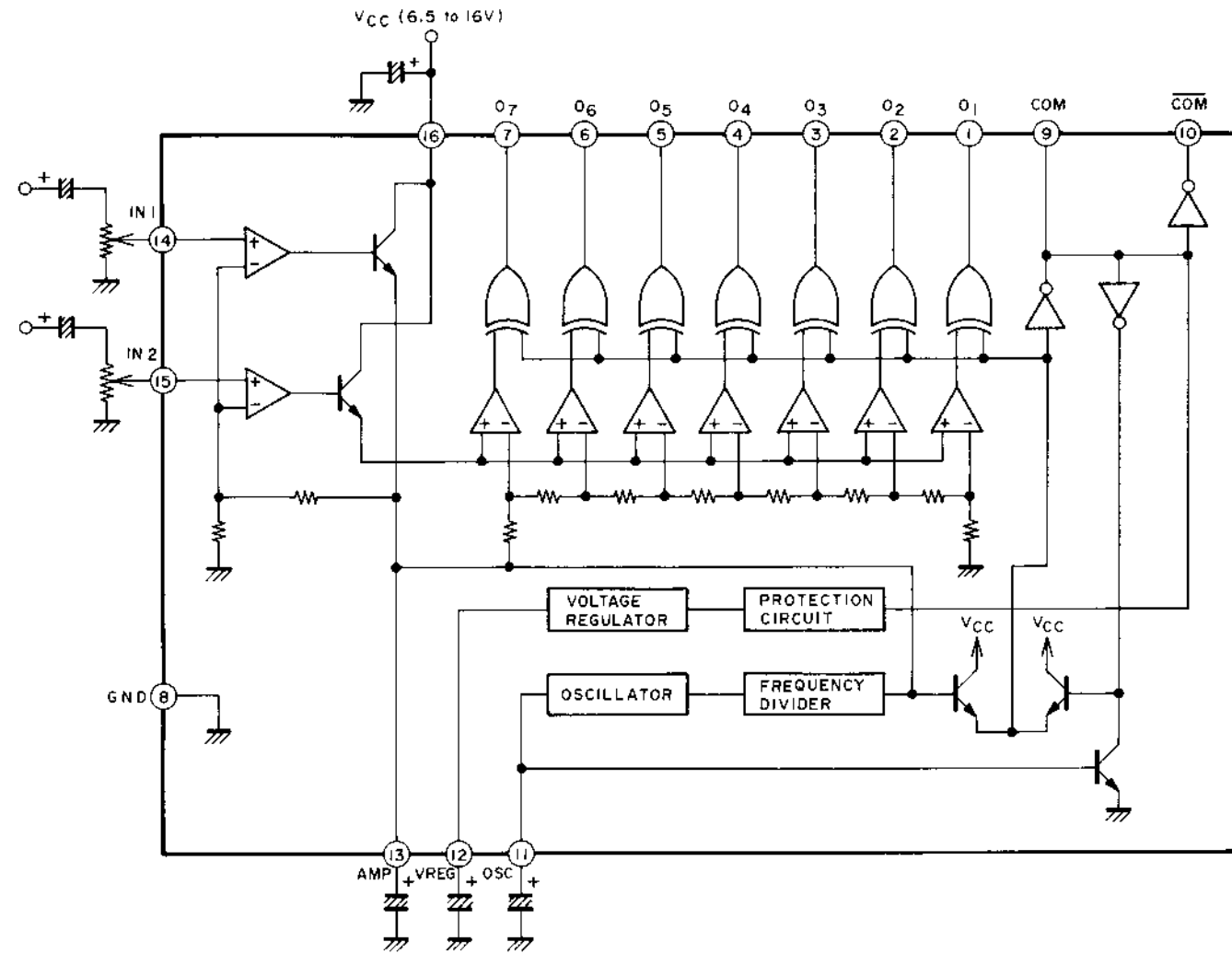

SURROUND PCB A1018A509B(-A)

B = NPN TRANSISTOR

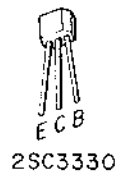

2SC3330

TR 1,2,3 ---- 2SC3330

AV-M313

03

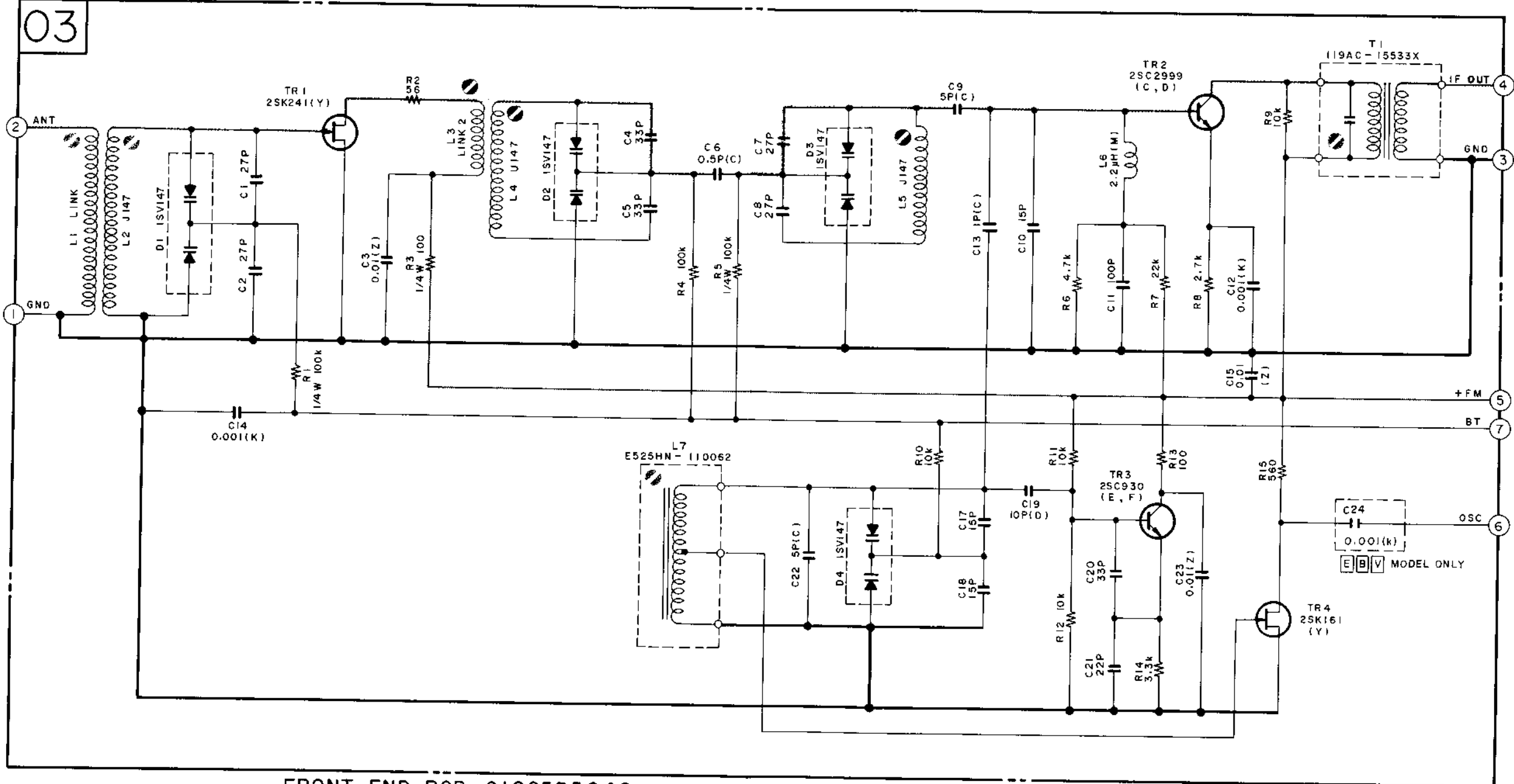

FRONT END PCB C1005B5040

B (POWER SUPPLY) LINE
 SIGNAL LINE

NOTE
 UNLESS OTHERWISE SPECIFIED
 ALL RESISTORS IN OHMS 1/6W(J)
 ALL CAPACITORS IN μ F 50WV(J)

AV-M313 FRONT END
 SCHEMATIC DIAGRAM
 NO. 8-8 860539B

001938