

AKAI SERVICE MANUAL

[Handwritten signature]

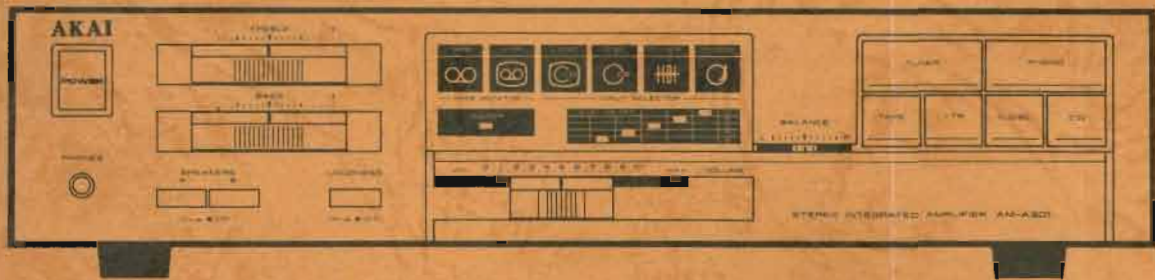

HX-A301W

STEREO INTEGRATED AMPLIFIER

MODEL **AM-A301**

SAFETY CHECK AFTER REPAIRING
 After repairing the unit, check the following items before using the unit.
 1. Check the power cord and plug for damage and ensure that the plug is fully inserted into the power outlet.
 2. Check the volume level and ensure that it is not set too high.
 3. Check the speaker terminals and ensure that the connections are correct.
 4. Check the ventilation holes and ensure that they are not blocked.
 5. Check the unit for any signs of damage or overheating.



I. SPECIFICATIONS

II. DISMANTLING OF THE UNIT

III. CONTROLS

IV. ADJUSTMENT

V. PREVENTION OF ELECTRIC SHOCK

VI. PREVENTION OF FIRE

MANUAL



Observe that wires do not contact heat-producing parts (resistors, coils, metal film resistors, fuses, etc.).
 Check the replaced wire do not contact sharp edge or pointed part.
 After work, check surrounding location.
 Wires, solder, etc. do not touch the unit.

STEREO INTEGRATED AMPLIFIER

MODEL AM-A301

SECTION 1	SERVICE MANUAL	3
SECTION 2	PARTS LIST	9

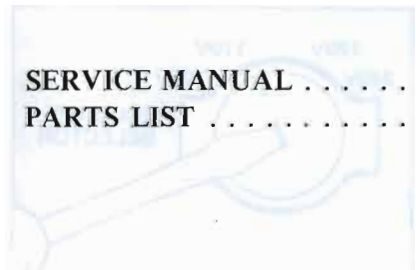

SAFETY INSTRUCTIONS

SAFETY CHECK AFTER SERVICING

Confirm the specified insulation resistance between power cord plug prongs and externally exposed parts of the set is greater than 10 Mohms, but for equipment with external antenna terminals (tuner, receiver, etc.) and is intended for **C** or **A**, specified insulation resistance should be more than 2.2 Mohms (ground terminals, microphone jacks, headphone jacks, line-in-out jacks etc.)

PRECAUTIONS DURING SERVICING

1. Parts identified by the Δ symbol parts are critical for safety.
Replace only with parts number specified.
2. In addition to safety, other parts and assemblies are specified for conformance with such regulations as those applying to spurious radiation. These must also be replaced only with specified replacements.
Examples: RF converters, tuner units, antenna selector switches, RF cables, noise blocking capacitors, noise blocking filters, etc.
3. Use specified internal wiring. Note especially:
 - 1) Wires covered with PVC tubing
 - 2) Double insulated wires
 - 3) High voltage leads
4. Use specified insulating materials for hazardous live parts. Note especially:
 - 1) Insulation Tape
 - 2) PVC tubing
 - 3) Spacers (Insulating Barriers)
 - 4) Insulation sheets for transistors
 - 5) Plastic screws for fixing microswitch (especially in turntable)
5. When replacing AC primary side components (transformers, power cords, noise blocking capacitors, etc.), wrap ends of wires securely about the terminals before soldering.

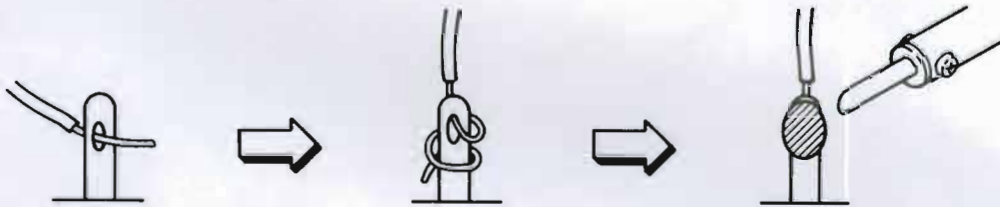

6. Observe that wires do not contact heat producing parts (heatsinks, oxide metal film resistors, fusible resistors, etc.).
7. Check that replaced wires do not contact sharp edged or pointed parts.
8. Also check areas surrounding repaired locations.
9. Use care that foreign objects (screws, solder droplets, etc.) do not remain inside the set.

VOLTAGE CONVERSION

Models for Canada, USA, Europe, UK and Australia are not equipped with this facility, Each machine is preset at the factory according to destination, but some machines can be set to 110V, 120V, 220V, or 240V as required.

If your machine's voltage can be converted:

Before connecting the power cord, turn the VOLTAGE SELECTOR located on the rear panel with a screwdriver until the correct voltage is indicated.

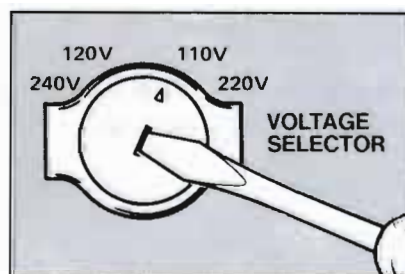

SECTION 1

SERVICE MANUAL

TABLE OF CONTENTS

- I. SPECIFICATIONS 4
- II. DISMANTLING OF UNIT 5
- III. CONTROLS 6
- IV. PRINCIPAL PARTS LOCATION 7
- V. ADJUSTMENT 7
- VI. PC BOARD TITLE AND IDENTIFICATIONS 8

For basic adjustments, measuring methods, and operating principles, refer to GENERAL TECHNICAL MANUAL.

I. SPECIFICATIONS

POWER AMPLIFIER SECTION

POWER OUTPUT (by FTC) 20Hz to 20kHz	8 ohms 60W/0.05%
POWER BANDWIDTH (IHF -3dB, 8 ohms)	10Hz to 60kHz (0.3%)
S/N (IHF-A)	PHONO 72dB AUX 95dB
RESIDUAL NOISE (8 ohms)	0.5mV
CHANNEL SEPARATION (IHF, 1kHz)	55dB
DAMPING FACTOR (1kHz, 8 ohms)	30
REQUIRED SPEAKER IMPEDANCE	8 to 16 ohms

PRE AMPLIFIER SECTION

INPUT SENSITIVITY/IMPEDANCE	PHONO 2mV/47kohms AUX 150mV/47kohms TUNER 150mV/47kohms TAPE 150mV/47kohms
OUTPUT LEVEL/IMPEDANCE	TAPE REC 150mV/1kohms
FREQUENCY RESPONSE	PHONO (RIAA DEVIATION) ±0.5dB TUNER, AUX, TAPE 5Hz to 100kHz (-3dB)
TONE CONTROL	BASS ±8dB TREBLE ±8dB
PHONO MAX. INPUT LEVEL	120mV
POWER REQUIREMENTS	120V, 60Hz for USA & Canada 220V, 50Hz for Europe except UK 240V, 50Hz for UK & Australia 110V/120V/220V/240V, 50Hz/60Hz convertible for other countries
DIMENSIONS	440(W) × 100(H) × 267(D) mm (17.3 × 3.9 × 10.5 inches)

* For improvement purposes, specifications and design are subject to change without notice.

II. DISMANTLING OF UNIT

In case of trouble, etc. necessitating dismantling, please dismantle in the order shown in the photographs. Reassemble in reverse order.

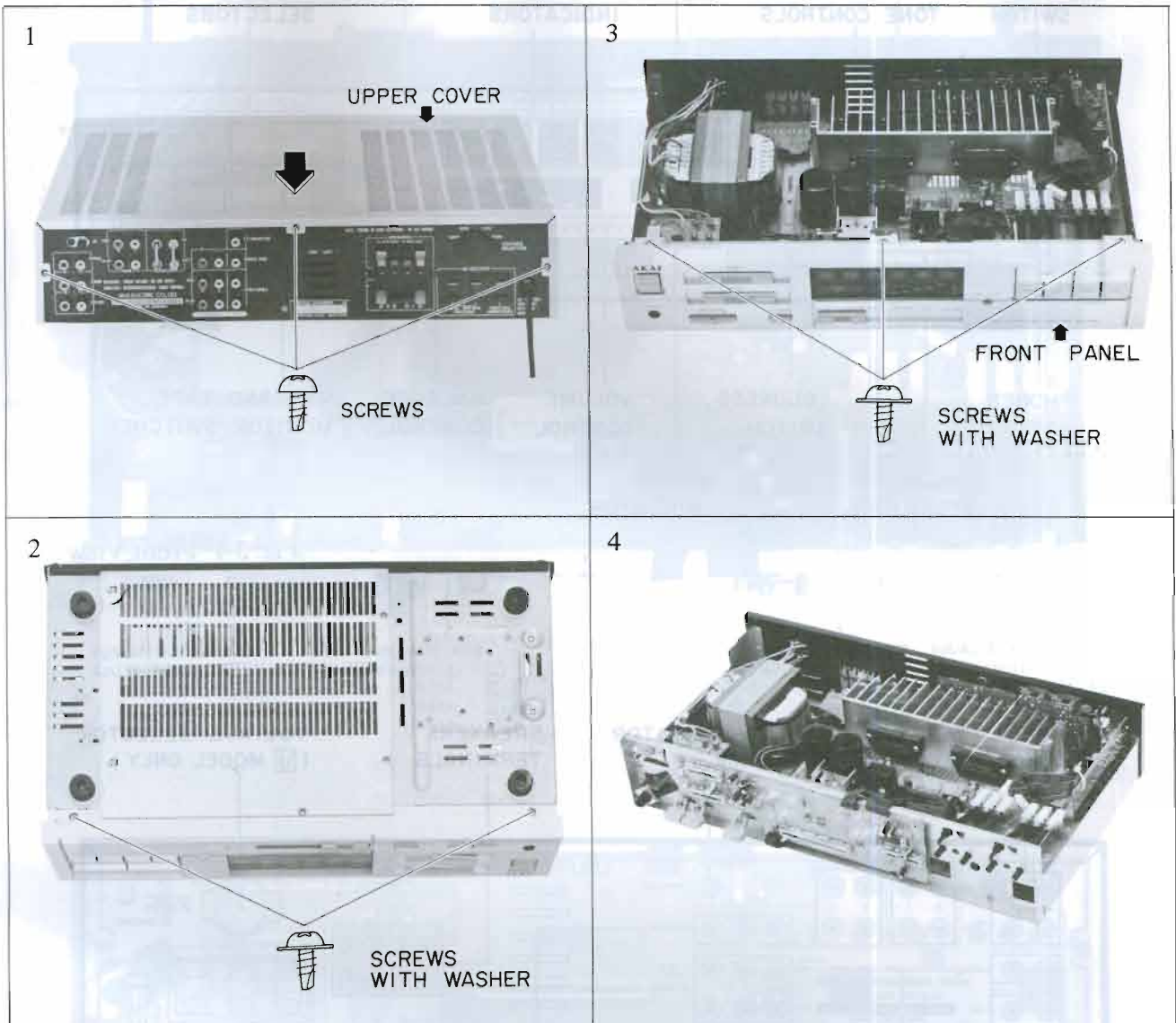

V. ADJUSTMENT

III. CONTROLS

DISMANTLING OF UNIT

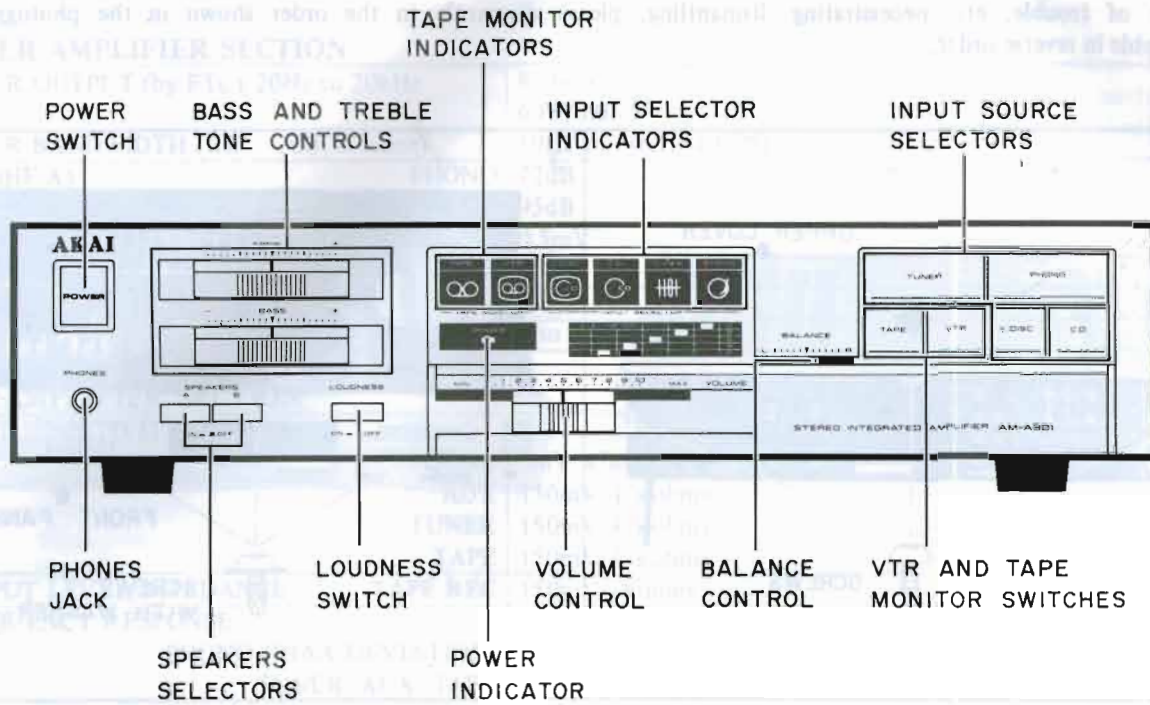

Fig. 3-1 Front View

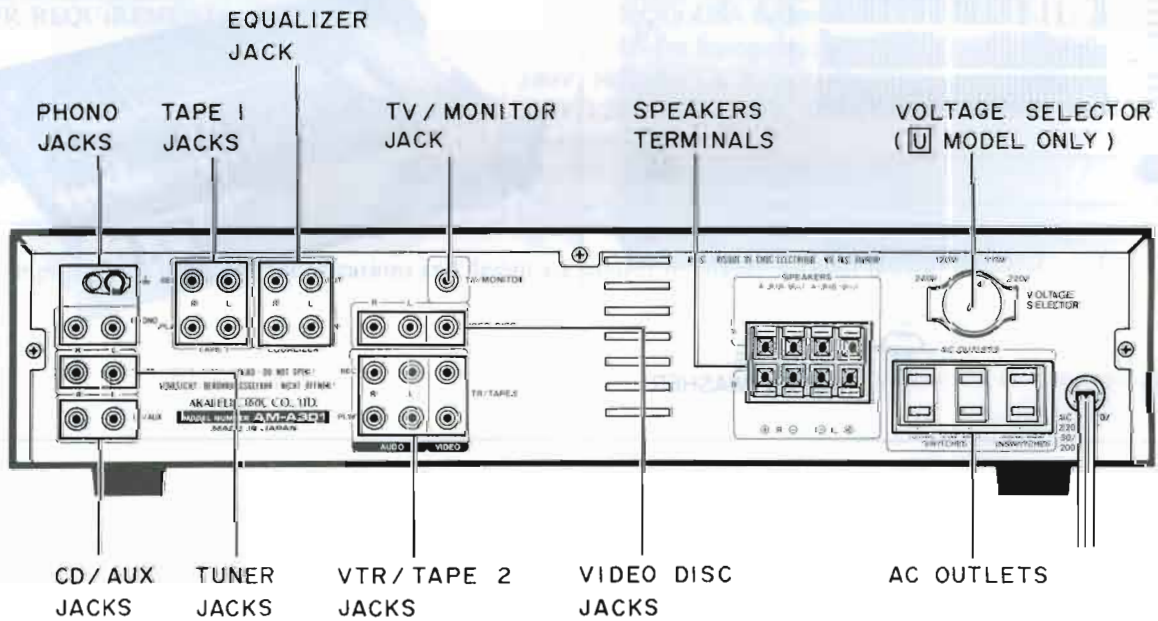

Fig. 3-2 Rear View

IV. PRINCIPAL PARTS LOCATION

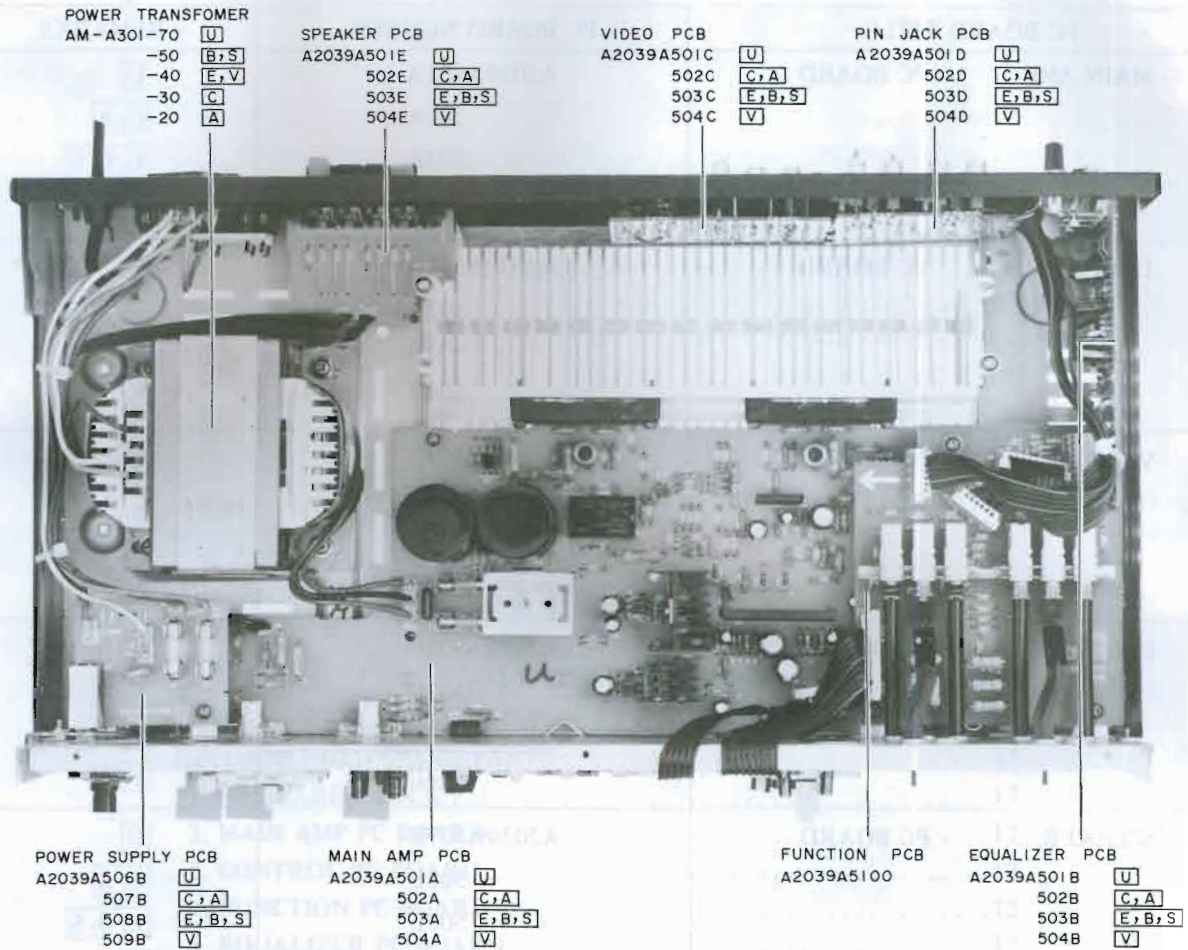

Fig. 4-1 Top View

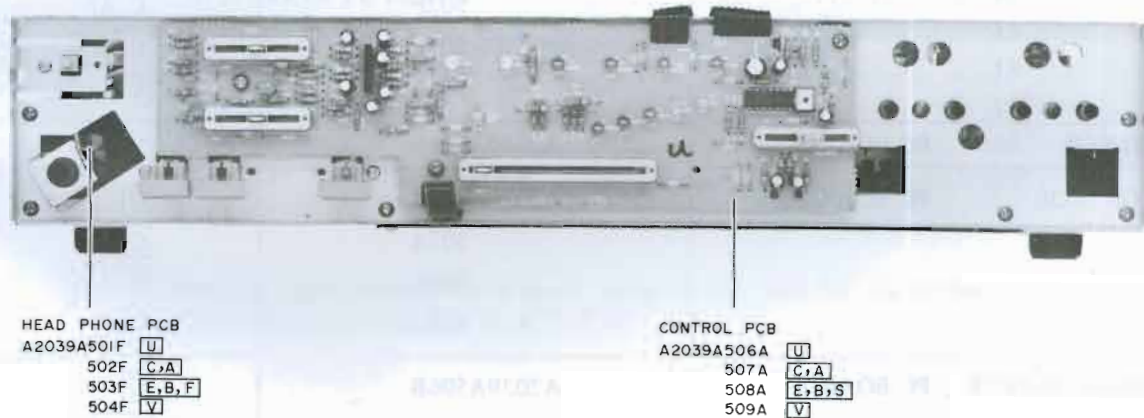

Fig. 4-2 Front View

V. ADJUSTMENTS

No Adjustment is Necessary for this model.

VI. PC BOARD TITLE AND IDENTIFICATIONS

PC BOARD TITLE		PC BOARD NUMBER	REMARKS
MAIN AMP	PC BOARD	A2039A501A	U
		502A	C, A
		503A	E, B, S
		504A	V
EQUALIZER	PC BOARD	A2039A501B	U
		502B	C, A
		503B	E, B, S
		504B	V
VIDEO	PC BOARD	A2039A501C	U
		502C	C, A
		503C	E, B, S
		504C	V
PIN JACK	PC BOARD	A2039A501D	U
		502D	C, A
		503D	E, B, S
		504D	V
SPEAKER	PC BOARD	A2039A501E	U
		502E	C, A
		503E	E, B, S
		504E	V
HEADPHONE	PC BOARD	A2039A501F	U
		502F	C, A
		503F	E, B, S
		504F	V
FILTER	PC BOARD	A2039A504G	V
CONTROL	PC BOARD	A2039A506A	U
		507A	C, A
		508A	E, B, S
		509A	V
POWER SUPPLY	PC BOARD	A2039A506B	U
		507B	C, A
		508B	E, B, S
		509B	V
FUNCTION	PC BOARD	A2039A5100	

SECTION 2

PARTS LIST

TABLE OF CONTENTS

RECOMMENDED SPARE PARTS	11
1. PC BOARD BLOCK	12
2. MAIN AMP PC BOARD	12
3. CONTROL PC BOARD	12
4. FUNCTION PC BOARD	12
5. EQUALIZER PC BOARD	12
6. VIDEO PC BOARD	12
7. PIN JACK PC BOARD	12
8. SPEAKER PC BOARD	12
9. HEAD PHONE PC BOARD	13
10. POWER SUPPLY PC BOARD	13
11. FILTER PC BOARD	13
12. ASSEMBLY BLOCK	14
13. FINAL ASSEMBLY BLOCK	15
INDEX	16

Resistor and Capacitor which is not listed in this parts list, please refer to COMMON LIST FOR SERVICE PARTS.

ATTENTION

1. When placing an order for parts, be sure to list the parts no., model no., and description of each part. If any of this information is omitted, there are instances in which parts cannot be shipped or the wrong parts will be delivered.
2. Please be careful not to make a mistake in the parts no. If the parts no. is in error, a part different from the one ordered may be delivered.
3. Because part numbers and part definitions and supply in the Preliminary Parts List may have been the subject of changes, please use this parts list for all future reference.

HOW TO USE THIS PARTS LIST

1. This Parts List shows those parts which are considered necessary for repairs. Other parts, such as resistors and capacitors, are shown in the "Common List for Service Parts" from which these parts should be selected and parts.
2. The Recommended Spare Parts List shows those parts in the Parts List which are considered particularly important for service.
3. Parts not shown in the Parts List and "Common List for Service Parts" will not in principle be supplied.
4. How to read the parts list

a) Mechanism Block

b) P.C Board Block

2. HEAD BASE BLOCK

REF. NO.	PART NO.	DESCRIPTION
2-1 ^x	BH-T2023A320A	HEAD BASE BLOCK GX-F66R
2-2	HP-H2206A010A	HEAD R/P PR4-SFU C
2-3	ZS-477876	PAN20×03STL CMT
2-4	ZS-536488	BID20×08STL CMT
2-5	ZG-402895	CS ANGLE ADJUST SPRING

SP (Service Parts) Classification

A small "x" indicates the inability to show that particular part in the Photo or Illustration.

This number corresponds with the individual parts index number in that figure

This number corresponds with the Figure Number

6. SYS. CON. P C BOARD BLOCK

REF. NO.	PART NO.	DESCRIPTION
6-1	BA-T2034A070A	PC SYS CON BLK GX-F44R
6-IC1	EI-324536	IC HD14049BP
6-IC2	EI-336801	IC MB8841-564M
6-IC3	EI-331661	IC SN7405N
6-IC4	EI-336725	IC M54527P
6-TR1to4	ET-200985	TR 2SC2603 F,G
6-TR5to28	ET-554657	TR 2SA733A P,Q
6-D1	ED-318292	D SILICON H 1S2473T-77 T26
6-D2to4	ED-308952	D GERMA V 1K34A-LR F07
6-D5to10	ED-318292	D SILICON H 1S2473T-77 T26
6-X1	EI-318384	OSC X'TAL NC-18C 3.579545MHZ

SP (Service Parts) Classification

These reference symbols correspond with component symbols in the Schematic Diagrams.

5. The kind of part and its installation position can both be determined by the Part Number. To determine where a part number is listed, utilize the Parts Index at the end of the Parts List. It is necessary first of all to find the Part Number. This can be accomplished by using the Reference Number listed at the right of the part number in the Parts Index.

WARNING

⚠ INDICATES SAFETY CRITICAL COMPONENTS. FOR CONTINUED SAFETY, REPLACE SAFETY CRITICAL COMPONENTS ONLY WITH MANUFACTURE'S RECOMMENDED PARTS

AVERTISSEMENT

⚠ IL INDIQUE LES COMPOSANTS CRITIQUES DE SÉCURITÉ. POUR MAINTENIR LE DEGRÉ DE SÉCURITÉ DE L'APPAREIL, NE REMPLACER QUE DES PIÈCES RECOMMANDÉES PAR LE FABRICANT

RECOMMENDED SPARE PARTS

Because, if the parts listed below are on hand, almost any repair can be accomplished, we suggest that you stock these Recommended Spare Parts Items.

REF. NO.	PART NO.	DESCRIPTION
1 N	BT-358548	△ TRANS POWER AM-A301-20(A) [A]
2 N	BT-358546	△ TRANS POWER AM-A301-30(C) [C]
3 N	BT-358549	△ TRANS POWER AM-A301-40 (E,V) [E,V]
4 N	BT-358550	△ TRANS POWER AM-A301-50(B,S) [B,S]
5 N	BT-358545	△ TRANS POWER AM-A301-70(U) [U]
6	ED-355605	D LED AY5525S AMBER
7	ED-356424	D LED BG5525S GREEN
8	ED-356421	D LED BR5505S RED
9	ED-200749	D SILICON DBA60-K15 400/6.0A
10	ED-348990	D SILICON H DS446
11	ED-301911	D SILICON H DS448
12	ED-328486	D ZENER H HZ15 3
13 N	EF-355398	△ FUSE BET T 2.00A 250V [B]
14 N	EF-355399	△ FUSE BET T 5.00A 250V [B]
15	EF-601301	△ FUSE SEMKO T 2.00A 250V [E,V,S]
16	EF-249851	△ FUSE SEMKO T 5.00A 250V [E,V,S]
17	EF-326639	△ FUSE TSC A 250V 3.15A [U]
18	EF-341260	△ FUSE TSC A 250V 8.00A [U]
19	EF-346139	△ FUSE TSC 125V 5.00A [C,A]
20	EF-345658	△ FUSE TSC 125V 8.00A [C,A]
21	EI-352041	△ IC STK1050A
22 N	EI-358533	△ IC STK3042-3
23	EI-353852	IC LA7016
24 N	EI-358562	IC LB1416
25	EI-337228	IC M5218L0
26	EI-349719	IC M5218P
27	EI-344764	IC M5218P-21
28	EI-354080	IC UPC1237H
29	EQ-337159	△ RELAY POW G4Z-2282P 2N0 24V
30	ER-331188	△ R FUSE ERD2FC S10 1/4W 8R2J
31	ER-328278	△ R FUSE ERD2FC 1/4W 10R0G
32	ER-200746	△ R FUSE ERD2FC 1/4W 1000G
33	ES-337902	△ SW PUSH SDLD1P002 01-1
34	ES-349070	△ SW SELECTOR YKDS11-0002 02-4 [U]
35 N	ES-358556	SW PUSH ESB-621519 2THROW
36 N	ES-358555	SW PUSH ESB-62672 2-02-02S
37	ES-358564	SW PUSH ESB-62969 6 THROW
38	ET-347026	△ TR 2SB507HP E,F
39	ET-344176	△ TR 2SD313HP F
40 N	ET-355216	TR 2SA1317 T,U
41	ET-305463	TR 2SA970 GR,BL
42	ET-307195	TR 2SC2240 GR,BL
43	ET-308141	TR 2SC2603 G
44 N	EV-358539	VR SLIDE 25P1SVOF W105
45 N	EV-358541	VR SLIDE 25P2SV C104
46 N	EV-358563	VR SLIDE 60P2SVOM B254

"NOTE" N: New Parts

SYMBOL FOR DESTINATION

- [A] : AAL (USA)
- [B] : UK (England)
- [C] : CSA (Canada)
- [E] : CEE (Europe)
- [S] : SAA (Australia)
- [U] : U/T (Universal Area)
- [V] : VDE (West Germany)

1. PC BOARD BLOCK

REF. NO.	PART NO.	DESCRIPTION
1-1A	BA-A2039A020A	PC MAIN BLK AM-A301(U)
1-1B	BA-A2039A020B	PC MAIN BLK AM-A301(C,A)
1-1C	BA-A2039A020C	PC MAIN BLK AM-A301(E,B,S)
1-1D	BA-A2039A020D	PC MAIN BLK AM-A301(V)
1-2A	BA-A2039A030A	PC CONTROL BLK AM-A301(U)
1-2B	BA-A2039A030B	PC CONTROL BLK AM-A301(C,A)
1-2C	BA-A2039A030C	PC CONTROL BLK AM-A301(E,B,S)
1-2D	BA-A2039A030D	PC CONTROL BLK AM-A301(V)

"NOTES"

(1) PC MAIN BLK consists of following PC BOARDS.

- MAIN AMP PC BOARD
- EQUALIZER PC BOARD
- VIDEO PC BOARD
- PIN JACK PC BOARD
- SPEAKER PC BOARD
- HEAD PHONE PC BOARD
- FILTER PC BOARD

(2) PC CONTROL BLK consists of following PC BOARDS.

- CONTROL PC BOARD
- POWER SUPPLY PC BOARD

2. MAIN AMP PC BOARD

REF. NO.	PART NO.	DESCRIPTION
MAIN AMP PC BOARD		
2-IC1	EI-358533	△ IC STK3042-3
2-IC3	EI-337228	IC M5218L0
2-IC4	EI-354080	IC UPC1237H
2-TR1	ET-307195	TR 2SC2240 GR,BL
2-TR2	ET-305463	TR 2SA970 GR,BL
2-TR3	ET-344176	△ TR 2SD313HP F
2-TR4	ET-347026	△ TR 2SB507HP E,F
2-D1,D2	ED-301911	D SILICON H DS448
2-D3,D4	ED-348990	D SILICON H DS446
2-D5,D6	ED-328486	△ D ZENER H HZ15 3
2-D7	ED-200749	△ D SILICON DBA60-K15 400/6.0A
2-SW1	ES-358555	SW PUSH ESB-62672 2-02-02S
2-SW2	ES-358556	SW PUSH ESB-621519 2-THROW
2-RL1	EQ-337159	△ RELAY POW G4Z-2282P 2N0 24V
2-L1	EO-337880	COIL FIX 2 202AK-018 2R2K
2-FR1	ER-200746	△ R FUSE ERD2FC 1/4W 1000G
2-FR2	ER-200746	△ R FUSE ERD2FC 1/4W 1000G
2-FR3	ER-331188	△ R FUSE ERD2FC S10 1/4W 8R2J
2-FR4	ER-328278	△ R FUSE ERD2FC 1/4W 10R0G
2-R12,R13	ER-337754	△ R OMF H S15 FS 1W 100J
2-R21	ER-333618	△ R CB H S15 FS RDS 1/2W 153J
2-R23	ER-338084	△ R OMF H SNP FS 2W 122J
2-R25	ER-355148	△ R OMF H S15 FS 2W 331J
2-R26	ER-328069	△ R CB H S10 FS RDS 1/4W 2R7J
2-R29	ER-333352	△ R CB H S10 FS RDS 1/4W 6R8J
2-C9,C10	EC-325320	C EC V F05 NP AWA 2R2M 50DC
2-C14	EC-311689	C EC V CUT NP 04D 331M 6.3DC
2-C20	EC-358559	C EC V CUT SM 682M 55.0DC
2-C23	EC-358559	C EC V CUT SM 682M 55.0DC
2-C24	EC-326583	C MMY V CUT CF921 473K 400DC

ASSEMBLY BLOCK

2-IC2	EI-352041	△ IC STK1050A
2-F3A	EF-341260	△ FUSE TSC A 250V 8.00A [U]
2-F3B	EF-345658	△ FUSE TSC 125V 8.00A [C,A]
2-F3C	EF-249851	△ FUSE SEMKO T 5.00A 250V [E,V,S]
2-F3D	EF-355399	△ FUSE BET T 5.00A 250V [B]
2-F4A	EF-341260	△ FUSE TSC A 250V 8.00A [U]
2-F4B	EF-345658	△ FUSE TSC 125V 8.00A [C,A]
2-F4C	EF-249851	△ FUSE SEMKO T 5.00A 250V [E,V,S]
2-F4D	EF-355399	△ FUSE BET T 5.00A 250V [B]

3. CONTROL PC BOARD

REF. NO.	PART NO.	DESCRIPTION
3-IC1	EI-358562	IC LB1416
3-IC2	EI-337228	IC M5218L0
3-TR1	ET-355216	TR 2SA1317 T,U
3-D1 to D3	ED-356424	D LED BG5525S GREEN
3-D4,D5	ED-356421	D LED BR5505S RED
3-D6 to D9	ED-356424	D LED BG5525S GREEN
3-D10,D11	ED-355605	D LED AY5525S AMBER
3-D12	ED-356421	D LED BR5505S RED
3-D13	ED-301911	D SILICON H DS448
3-VR1	EV-358539	VR SLIDE 25P1SV0F W105
3-VR2	EV-358563	VR SLIDE 60P2SV0M B254
3-VR3,VR4	EV-358541	VR SLIDE 25P2SV C104
3-R8	ER-333680	△ R CB H S15 FS RDS 1/2W 560J
3-R14	ER-663502	R CB H RD 1/2W 222J
3-R29	ER-333680	△ R CB H S15 FS RDS 1/2W 560J

4. FUNCTION PC BOARD

REF. NO.	PART NO.	DESCRIPTION
4-SW1	ES-358564	SW PUSH ESB-62969 6 THROW
4-R1 to R6	ER-321153	△ R OMF H S15 FS 1W 102J

5. EQUALIZER PC BOARD

REF. NO.	PART NO.	DESCRIPTION
5-IC1	EI-344764	IC M5218P-21
5-L1	EO-338420	COIL FIX 2 FL12R202E 202K [V]
5-L2,L3	EO-336934	COIL FIX 1 LAL03KH 2R2M [V]
5-R9	ER-666865	△ R CB H FS RDS 1/2W 181J
5-P1	EJ-336904	PIN J AJC-036-ACB P 6P

6. VIDEO PC BOARD

REF. NO.	PART NO.	DESCRIPTION
6-IC1	EI-353852	IC LA7016
6-TR1 to TR4	ET-308141	TR 2SC2603 G
6-D1	ED-301911	D SILICON H DS448
6-L1 to L3	EO-336934	COIL FIX 1 LAL03KH 2R2M [V]
6-R7,R8	ER-322591	△ R CB H S10 FS RDS 1/4W 101J
6-J1	EJ-358561	PIN J LAP0020-0015R 10P

7. PIN JACK PC BOARD

REF. NO.	PART NO.	DESCRIPTION
7-IC1	EI-349719	IC M5218P
7-L1 to L3	EO-336934	COIL FIX 1 LAL03KH 2R2M [V]
7-P1,P2	EJ-343365	PIN J YMC21-0063 P 4P

8. SPEAKER PC BOARD

REF. NO.	PART NO.	DESCRIPTION
8-L1	EO-342936	COIL BALUN [V]
8-TM1	EJ-351485	TERMINAL PUSH YKD21-0148A S 8P

9. HEAD PHONE PC BOARD

REF. NO.	PART NO.	DESCRIPTION
9-L1	EO-336934	COIL FIX 1 LAL03KH 2R2M [V]
9-J1	EJ-358535	PHONE J 3P M1669-ACCB 6.3

10. POWER SUPPLY PC BOARD

REF. NO.	PART NO.	DESCRIPTION
POWER SUPPLY PC BOARD		
10-SW1	ES-337902	△ SW PUSH SDDL1P002 01-1
10-C1A	EC-320548	△ C CE V F 103Z 250AC [U]
10-C1B	EC-338411	△ C CE V FZ 103P 400AC [C,A]
10-C1C	EC-338496	△ C CE V FZ 472P 400AC [E,V,B,S]

ASSEMBLY BLOCK

10-F1A	EF-326639	△ FUSE TSC A 250V 3.15A [U]
10-F1B	EF-346139	△ FUSE TSC 125V 5.00A [C,A]
10-F1C	EF-601301	△ FUSE SEMKO T 2.00A 250V [E,V,S]
10-F1D	EF-355398	△ FUSE BET T 2.00A 250V [B]
10-F2	EF-326639	△ FUSE TSC A 250V 3.15A [U]

11. FILTER PC BOARD

REF. NO.	PART NO.	DESCRIPTION
11-L1	EO-338409	COIL LF FKOB160MH02 250UH [V]

ASSEMBLY BLOCK

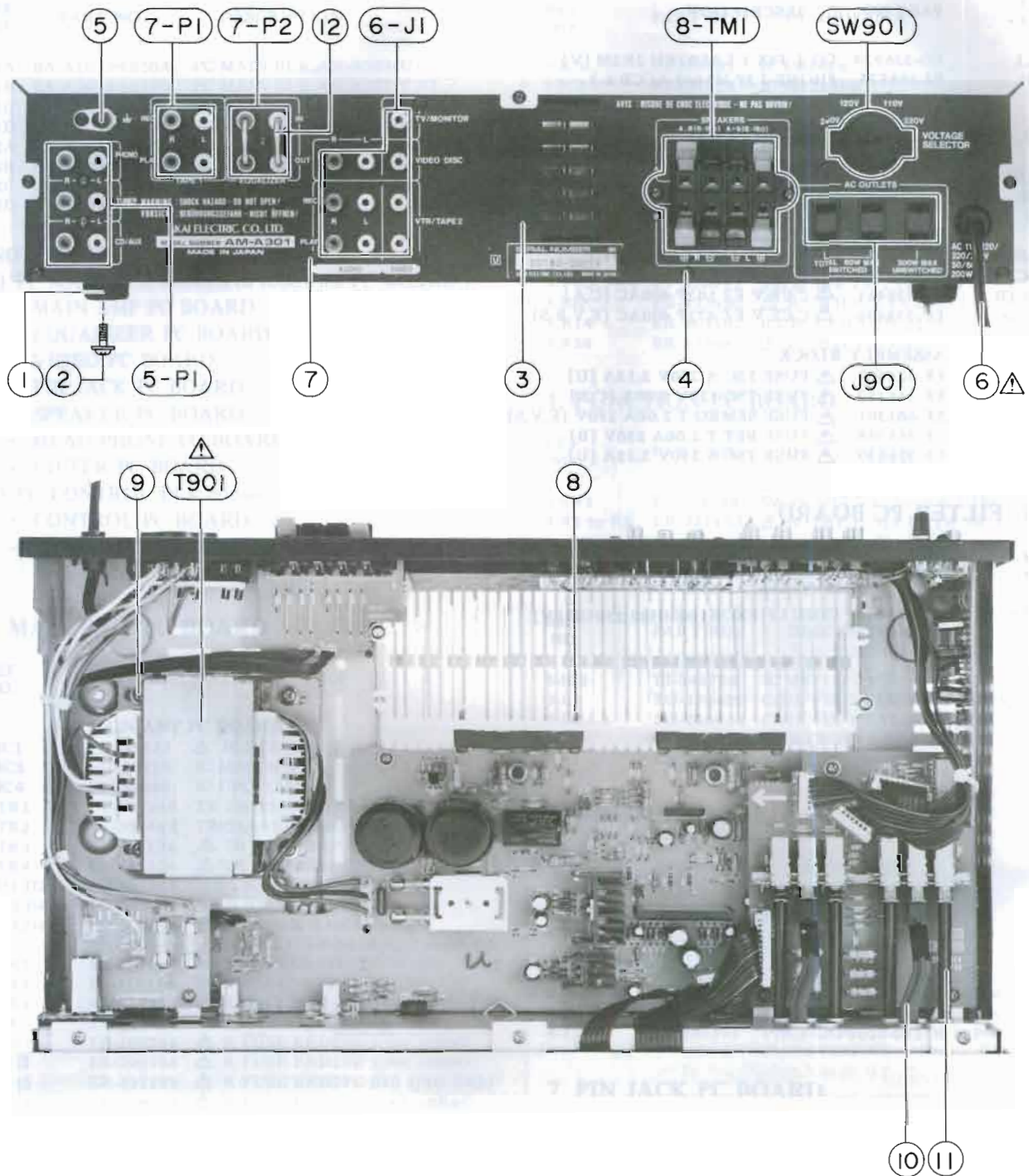

12. ASSEMBLY BLOCK

REF. NO.	PART NO.	DESCRIPTION
	ASSEMBLY BLOCK	
12-1	SA-332850	ROUND FOOT
12-2	ZS-331567	T2BR30X08STL CMT C080
12-3A	SP-358485A	PANEL REAR AM-A301(U)
12-3B	SP-358485B	PANEL REAR AM-A301(C,A)
12-3C	SP-358485C	PANEL REAR AM-A301(E)
12-3D	SP-358485M	PANEL REAR AM-A301(V)
12-3E	SP-358485D	PANEL REAR AM-A301(B,S)
12-4	ZS-308846	T2BR30X08STL BZN PROJECTION
12-5	EJ-329610	TERMINAL W/SCREW UB-0067 L 1P
12-6A	EW-354515	AC CORD 2 CORES KP-700A, VFF-CB U/T [U]

REF. NO.	PART NO.	DESCRIPTION
12-6B	EW-358513	△ AC CORD 2 CORES KD-8W, SPT-2-CB UC [C]
12-6C	EW-358515	△ AC CORD 2 CORES KP-8W, SPT-1-CB UC [A]
12-6D	EW-354625	△ AC CORD 2 CORES KP-419C, LTCE-2F E [E]
12-6E	EW-354513	△ AC CORD 2 CORES KP-419C, LTCE-2F EV [V]
12-6F	EW-354512	△ AC CORD 2 CORES LTBS-2F-CB B [B]
12-6G	EW-354514	△ AC CORD 2 CORES KP-560, L TSA2F-CB S [S]

FINAL ASSEMBLY BLOCK

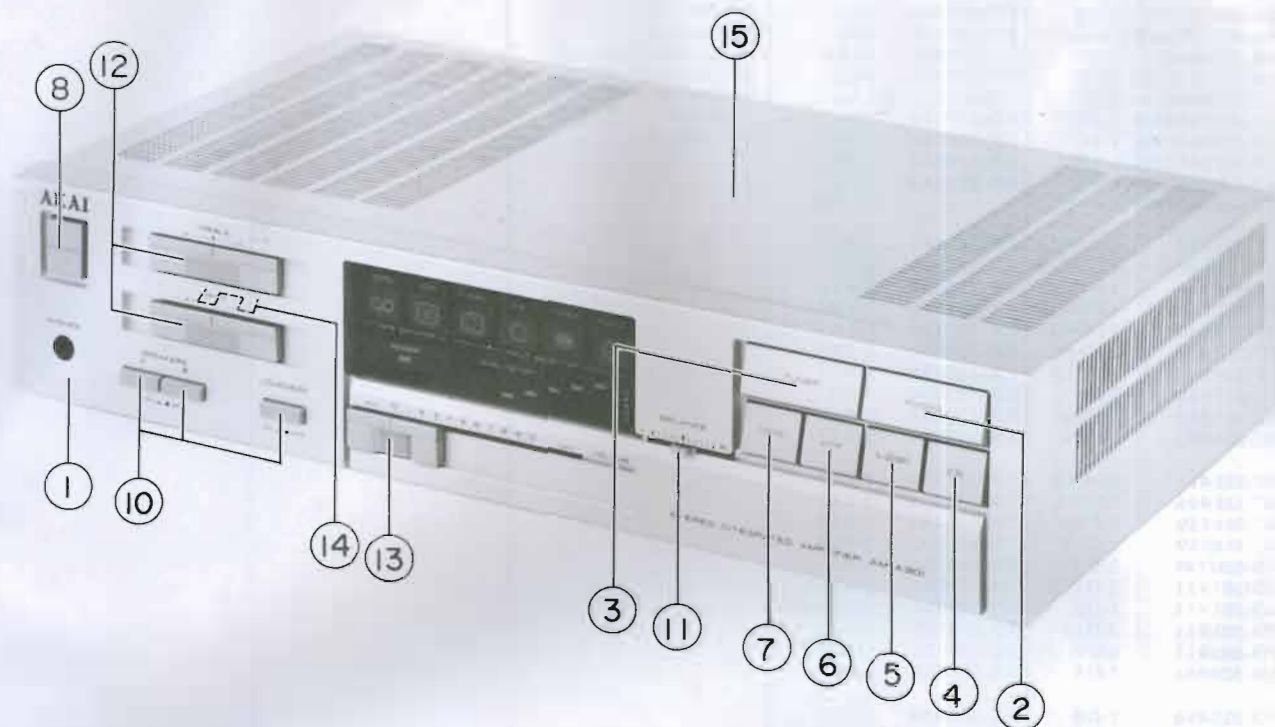

REF. NO.	PART NO.	DESCRIPTION
12-7	ZW-698308	RV NYL30×055 BL
12-8	ZS-321279	T2BR30×18STL CMT
12-9	ZS-346742	ST BID40×08STL CMT CUP
12-10	TA-358475	JOINT (A)
12-11	TA-358473A	JOINT (B)-I
12-12	EJ-348218	PLUG SHORT PIN P2138
12-T901A	BT-358545	△ TRANS POWER AM-A301-70(U)
12-T901B	BT-358546	△ TRANS POWER AM-A301-30(C)
12-T901C	BT-358548	△ TRANS POWER AM-A301-20(A)
12-T901D	BT-358549	△ TRANS POWER AM-A301-40(E,V)
12-T901E	BT-358550	△ TRANS POWER AM-A301-50(B,S)
12-J901A	EJ-337405	△ SOCKET OUTLET S2T733T164 JUC
12-J901B	EJ-352642	△ SOCKET OUTLET S2T733T114T
12-SW901	ES-349070	△ SW SELECTOR YKS11-0002 02-4
		[U]
		EQUALIZER PC BOARD
5-P1	EJ-336904	PIN J AJC-036-ACB P 6P
		VIDEO PC BOARD
6-J1	EJ-358561	PIN J LAP0020-0015R 10P
		PIN JACK PC BOARD
7-P1	EJ-343365	PIN J YMC21-0063 P 4P
7-P2	EJ-343365	PIN J YMC21-0063 P 4P
		SPEAKER PC BOARD
8-TM1	EJ-351485	TERMINAL PUSH YKD21-0148A
		S 8P

13. FINAL ASSEMBLY BLOCK

REF. NO.	PART NO.	DESCRIPTION
		PANEL FRONT BLOCK
13-1	BD-A2039A050A	PANEL FRONT BLK AM-A301
13-1B	BD-A2039A050B	PANEL FRONT BLK AM-A301-B
13-2	SK-358482E	KNOB (A) PHONO
13-2B	SK-358482A	KNOB (A)-B PHONO
13-3	SK-358482F	KNOB (A) TUNER
13-3B	SK-358482B	KNOB (A)-B TUNER
13-4	SK-358483E	KNOB (B) CD/AUX
13-4B	SK-358483A	KNOB (B)-B CD/ASX
13-5	SK-358483F	KNOB (B) V.DISC
13-5B	SK-358483B	KNOB (B)-B V.DISC
13-6	SK-358483G	KNOB (B) VTR/TAPE2
13-6B	SK-358483C	KNOB (B)-B VTR/TAPE2
13-7	SK-358483H	KNOB (B) TAPE1
13-7B	SK-358483D	KNOB (B)-B TAPE1
13-8	SK-343017C	KNOB POWER (2)
13-8B	SK-343017F	KNOB POWER-B
		FINAL ASSEMBLY BLOCK
13-9x	ZS-498273	T2BR30×08STL CMT PW080
		[PANEL FRONT FIX]
13-10	SK-358479B	KNOB (F-2)
13-10B	SK-358479A	KNOB (F-1)
13-11	SK-358477B	KNOB (C-2)
13-11B	SK-358477A	KNOB (C-1)
13-12	SK-358480B	KNOB (E-2)
13-12B	SK-358480A	KNOB (E-1)
13-13	SK-358474B	KNOB (D-2)
13-13B	SK-358474A	KNOB (D-1)
13-14	ZG-360943	SP TONE
13-15	SP-349925A	COVER UPPER
13-15B	SP-349925C	COVER UPPER-B

NOTE:

PANEL FRONT BLK consists of 13-2 to 13-8B.

SYMBOL FOR COLOR VARIATION

NON: STANDARD COLOR

B or BL BLACK

INDEX

PART NO.	REF. NO.	PART NO.	REF. NO.	PART NO.	REF. NO.	PART NO.	REF. NO.	PART NO.	REF. NO.
BA-A2039A020A	1-1A	EO-336934	9-L1	ZG-360943	13-14				
BA-A2039A020B	1-1B	EO-337880	2-L1	ZS-308846	12-4				
BA-A2039A020C	1-1C	EO-338409	11-L1	ZS-321279	12-8				
BA-A2039A020D	1-1D	EO-338420	5-L1	ZS-331567	12-2				
BA-A2039A030A	1-2A	EO-342936	8-L1	ZS-346742	12-9				
BA-A2039A030B	1-2B	EQ-337159	2-RL1	ZS-498273	13-9x				
BA-A2039A030C	1-2C	ER-200746	2-FR1	ZW-698308	12-7				
BA-A2039A030D	1-2D	ER-200746	2-FR2						
BD-A2039A050A	13-1	ER-321153	4-R1						
BD-A2039A050B	13-1B		to R6						
BT-358545	12-T901A	ER-322591	6-R7						
BT-358546	12-T901B	ER-322591	6-R8						
BT-358548	12-T901C	ER-328069	2-R26						
BT-358549	12-T901D	ER-328278	2-FR4						
BT-358550	12-T901E	ER-331188	2-FR3						
EC-311689	2-C14	ER-333352	2-R29						
EC-320548	10-C1A	ER-333618	2-R21						
EC-325320	2-C9	ER-333680	3-R8						
EC-325320	2-C10	ER-333680	3-R29						
EC-326583	2-C24	ER-337754	2-R12						
EC-338411	10-C1B	ER-337754	2-R13						
EC-338496	10-C1C	ER-338084	2-R23						
EC-358559	2-C20	ER-355148	2-R25						
EC-358559	2-C23	ER-663502	3-R14						
ED-200749	2-D7	ER-666865	5-R9						
ED-301911	2-D1	ES-337902	10-SW1						
ED-301911	2-D2	ES-349070	12-SW901						
ED-301911	3-D13	ES-358555	2-SW1						
ED-301911	6-D1	ES-358556	2-SW2						
ED-328486	2-D5	ES-358564	4-SW1						
ED-328486	2-D6	ET-305463	2-TR2						
ED-348990	2-D3	ET-307195	2-TR1						
ED-348990	2-D4	ET-308141	6-TR1						
ED-355605	3-D10		to TR4						
ED-355605	3-D11	ET-344176	2-TR3						
ED-356421	3-D4	ET-347026	2-TR4						
ED-356421	3-D5	ET-355216	3-TR1						
ED-356421	3-D12	EV-358539	3-VR1						
ED-356424	3-D1	EV-358541	3-VR3						
	to D3	EV-358541	3-VR4						
ED-356424	3-D6	EV-358563	3-VR2						
	to D9	EW-354512	12-6F						
EF-249851	2-F3C	EW-354513	12-6E						
EF-249851	2-F4C	EW-354514	12-6G						
EF-326639	10-F1A	EW-354515	12-6A						
EF-326639	10-F2	EW-354625	12-6D						
EF-341260	2-F3A	EW-358513	12-6B						
EF-341260	2-F4A	EW-358515	12-6C						
EF-345658	2-F3B	SA-332850	12-1						
EF-345658	2-F4B	SK-343017C	13-8						
EF-346139	10-F1B	SK-343017F	13-8B						
EF-355398	10-F1D	SK-358474A	13-13B						
EF-355399	2-F3D	SK-358474B	13-13						
EF-355399	2-F4D	SK-358477A	13-11B						
EF-601301	10-F1C	SK-358477B	13-11						
EI-337228	2-IC3	SK-358479A	13-10B						
EI-337228	3-IC2	SK-358479B	13-10						
EI-344764	5-IC1	SK-358480A	13-12B						
EI-349719	7-IC1	SK-358480B	13-12						
EI-352041	2-IC2	SK-358482A	13-2B						
EI-353852	6-IC1	SK-358482B	13-3B						
EI-354080	2-IC4	SK-358482E	13-2						
EI-358533	2-IC1	SK-358482F	13-3						
EI-358562	3-IC1	SK-358483A	13-4B						
EJ-329610	12-5	SK-358483B	13-5B						
EJ-336904	5-P1	SK-358483C	13-6B						
EJ-337405	12-J901A	SK-358483D	13-7B						
EJ-343365	7-P1	SK-358483E	13-4						
EJ-343365	7-P2	SK-358483F	13-5						
EJ-348218	12-12	SK-358483G	13-6						
EJ-351485	8-TM1	SK-358483H	13-7						
EJ-352642	12-J901B	SP-349925A	13-15						
EJ-358535	9-J1	SP-349925C	13-15B						
EJ-358561	6-J1	SP-358485A	12-3A						
EO-336934	5-L2	SP-358485B	12-3B						
EO-336934	5-L3	SP-358485C	12-3C						
EO-336934	6-L1	SP-358485D	12-3E						
	to L3	SP-358485M	12-3D						
EO-336934	7-L1	TA-358473A	12-11						
	to L3	TA-358475	12-10						

AKAI

MODEL AM-A301

SCHEMATIC DIAGRAM AND PC BOARDS

TABLE OF CONTENTS

1. IC'S LB1416, STK1050, STK3042	2
2. AM-A301 BLOCK DIAGRAM	3
3. AM-A301 SCHEMATIC DIAGRAM	4
4. CONTROL PCB, HEADPHONE PCB, MAIN AMP PCB, SPEAKER TERMINAL PCB	5
5. EQUALIZER PCB, FILTER PCB, FUNCTION PCB, PIN JACK PCB, POWER SUPPLY PCB, VIDEO PCB	6

LB-1416

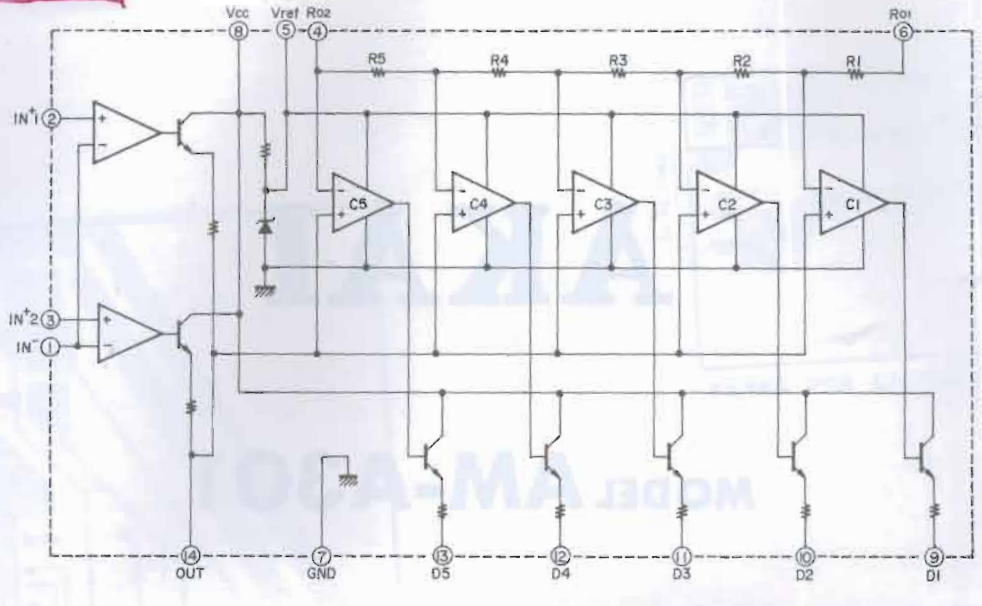

STK 1050

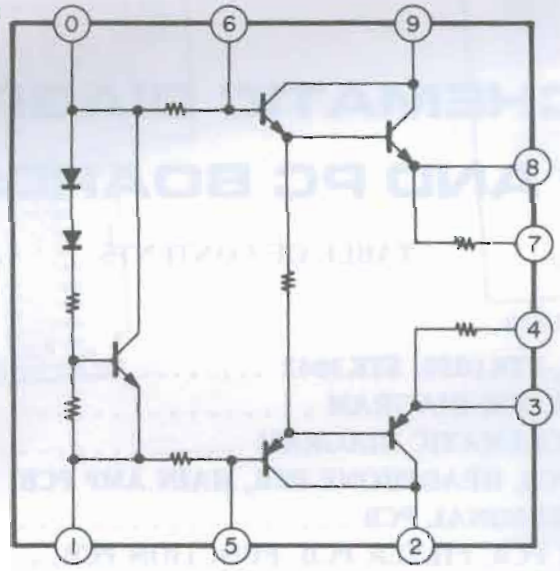

STK3042

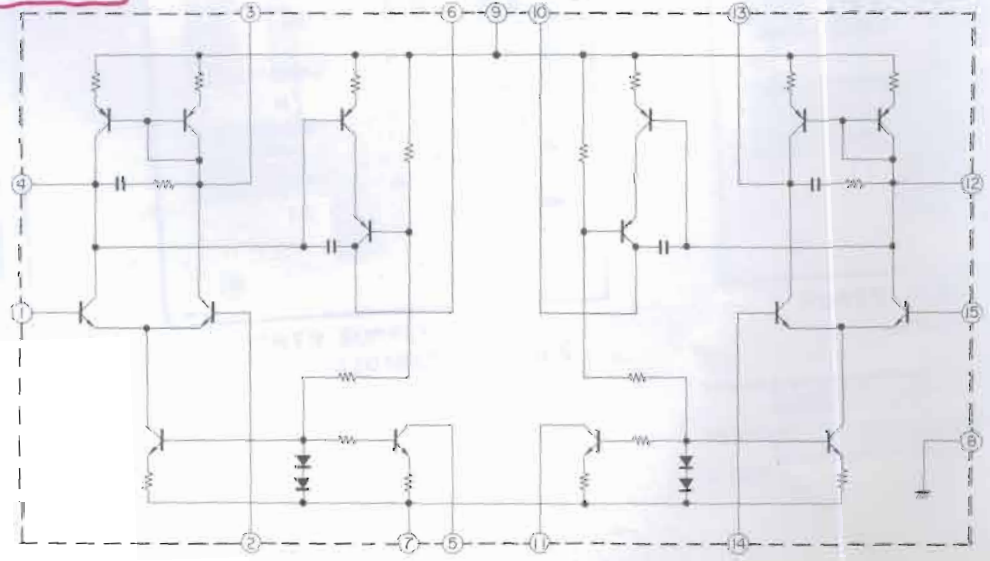

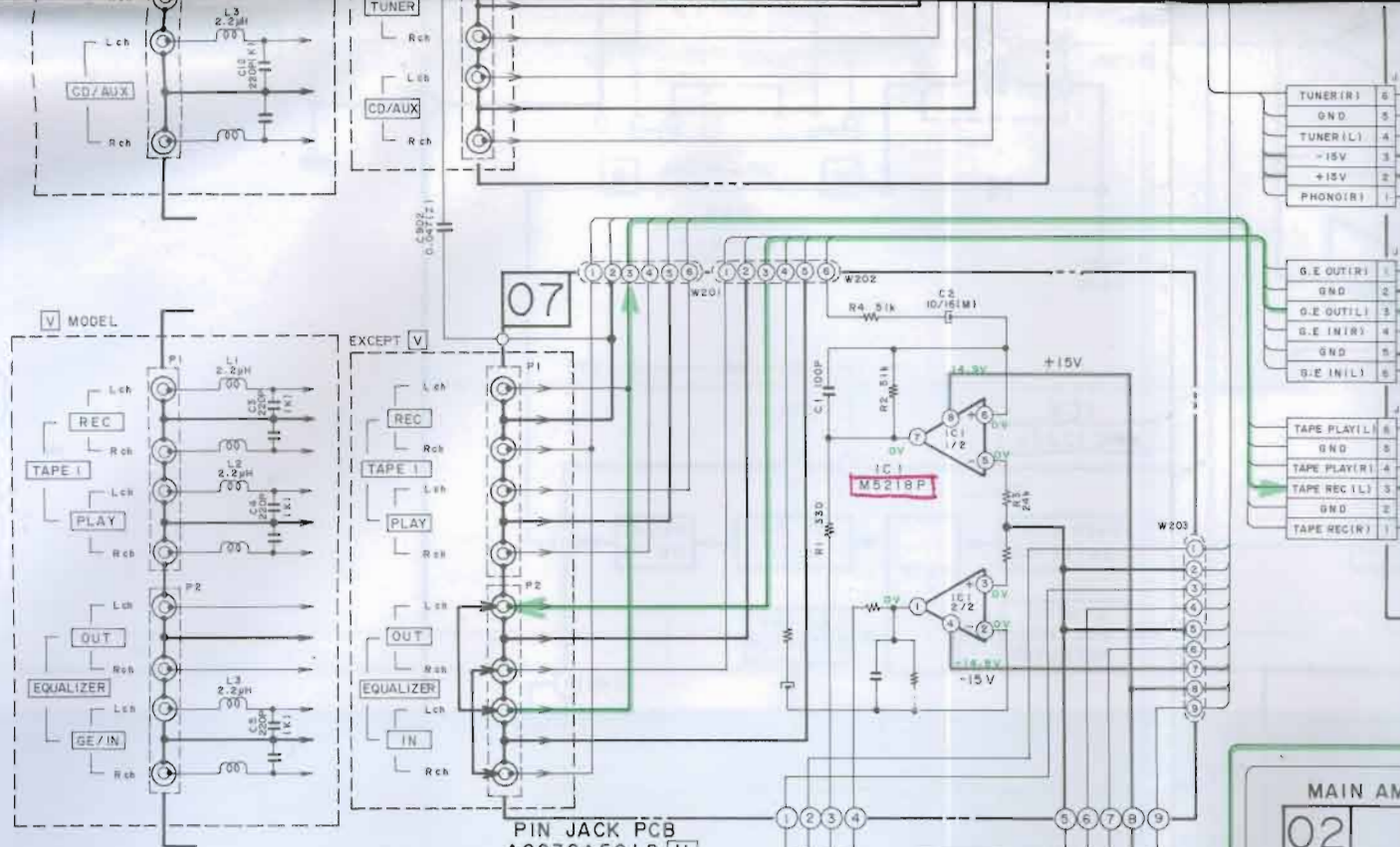

PIN JACK PCB
 A2039A501 D U
 A502 D C, A
 A503 D E, B, S
 A504 D V

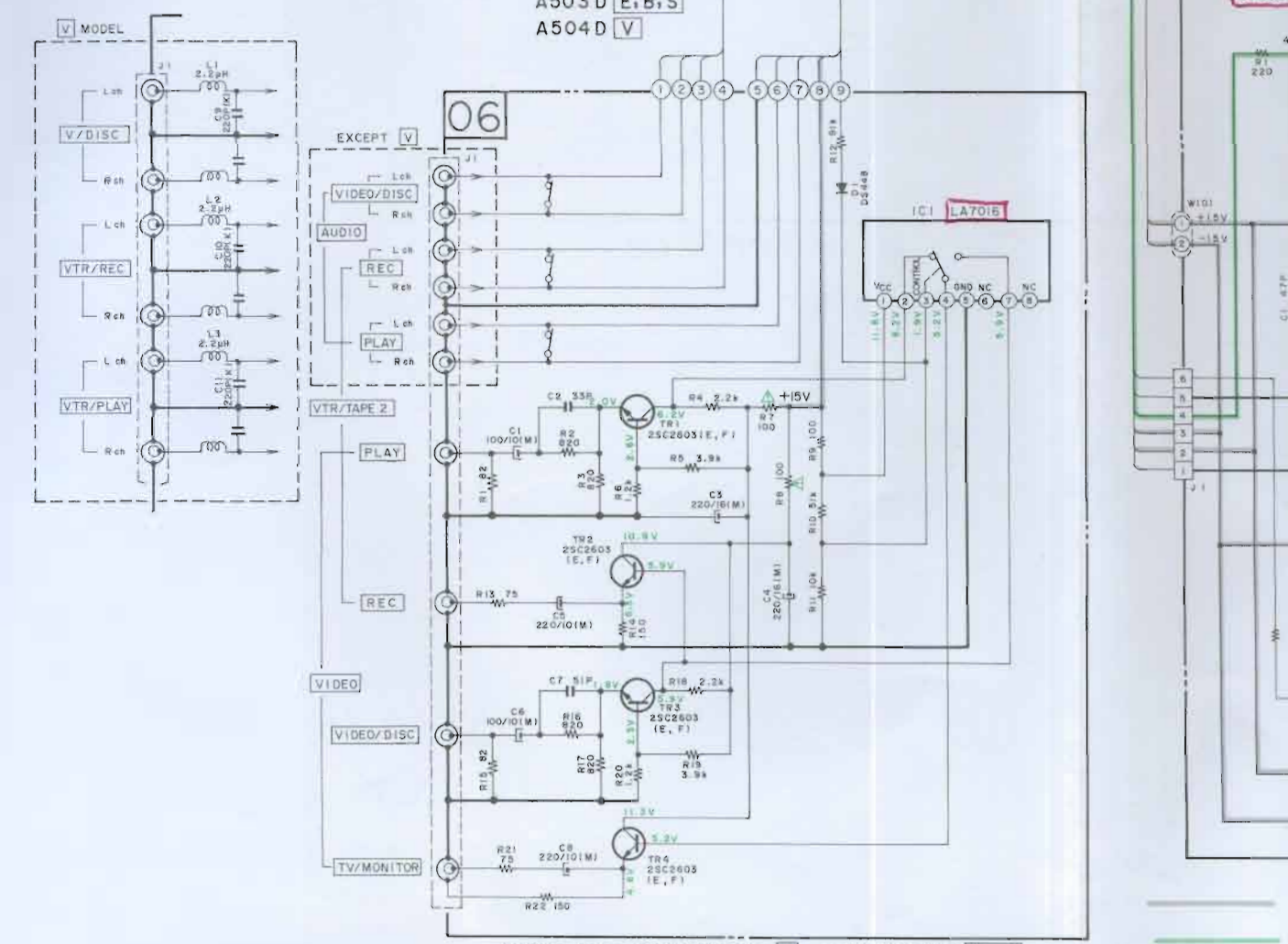

VIDEO PCB A2039A501C U A2039A502C C, A
 A2039A503C E, B, S A2039A504C V

001748

A B C D

3
4
5
6
7
8
4

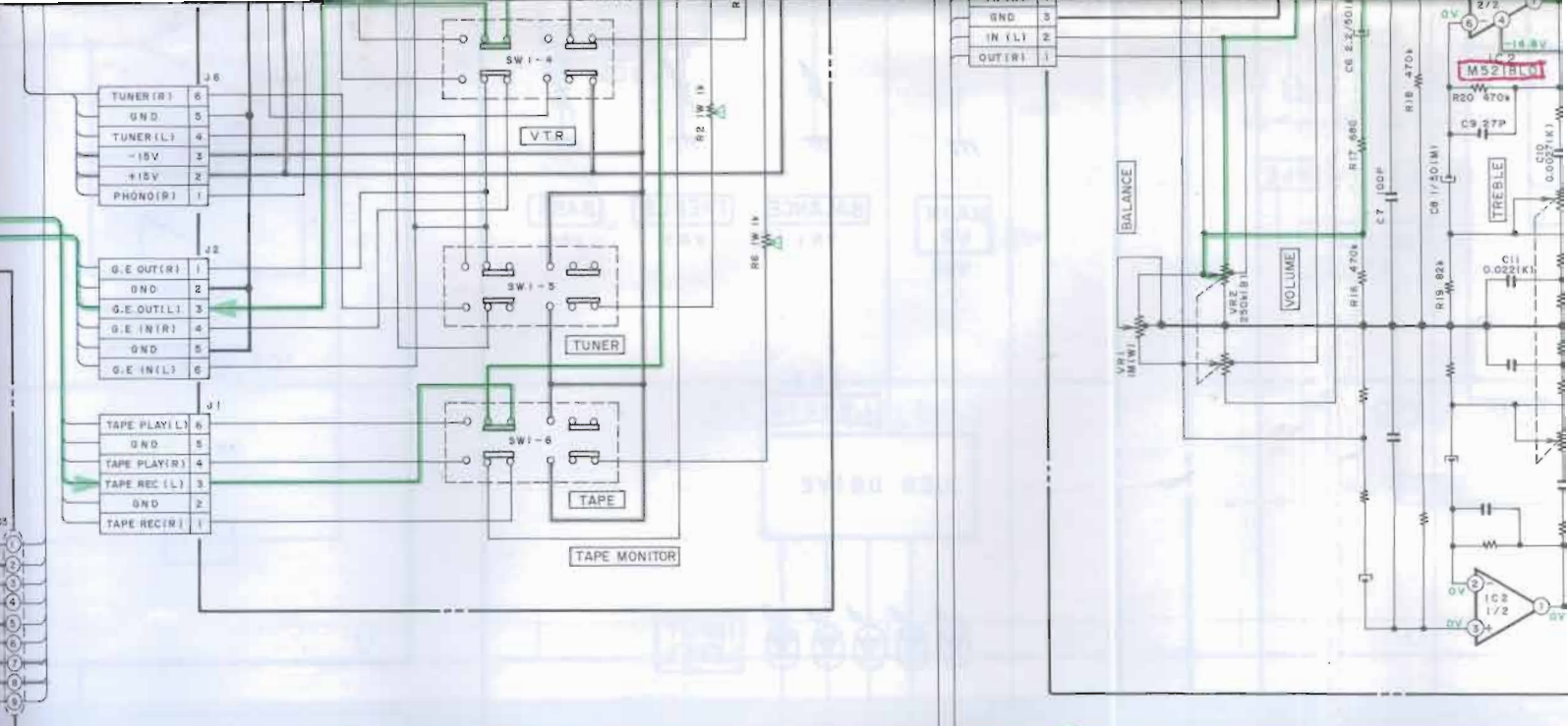

MAIN AMP PCB A2039A501A U A2039A502A C A A2039A503A E B S A2039A504A V

02

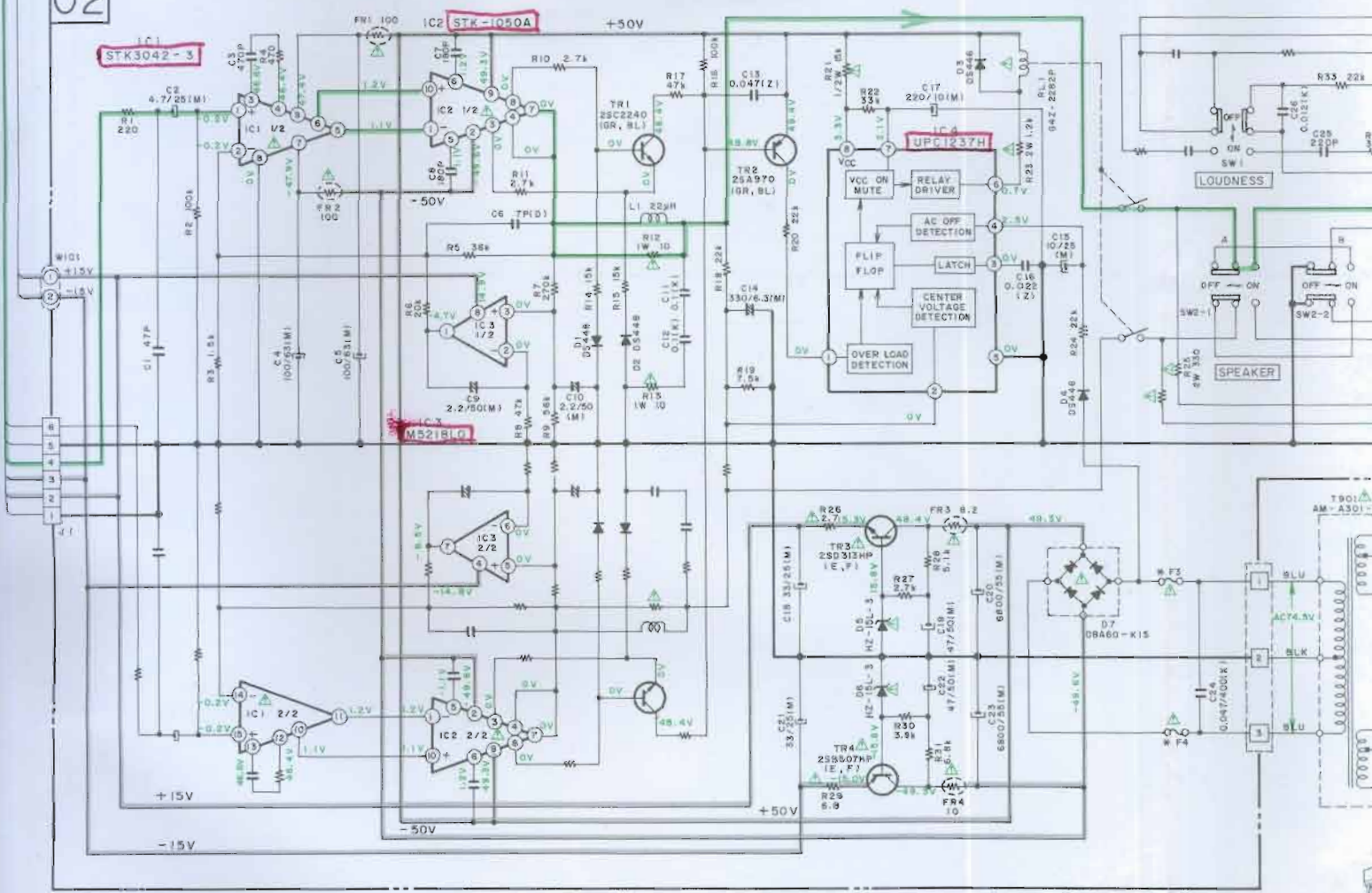

BIPOWER SUPPLY LINE

SIGNAL LINE

SIGNAL LINE IS INDICATED LEFT CHANNEL ONLY AT PHONO MODE.

WARNING: ⚠️ INDICATES SAFETY CRITICAL COMPONENTS. FOR CONTINUED SAFETY, REPLACE SAFETY CRITICAL COMPONENTS ONLY WITH MANUFACTURER'S RECOMMENDED PARTS.
 AVERTISSEMENT: ⚠️ INDIQUE LES COMPOSANTS CRITIQUES DE SÉCURITÉ. POUR MAINTENIR LE DEGRÉ DE SÉCURITÉ DE L'APPAREIL, NE REMPLACER QUE DES PIÈCES RECOMMANDÉES PAR LE FABRICANT.

E

F

G

H

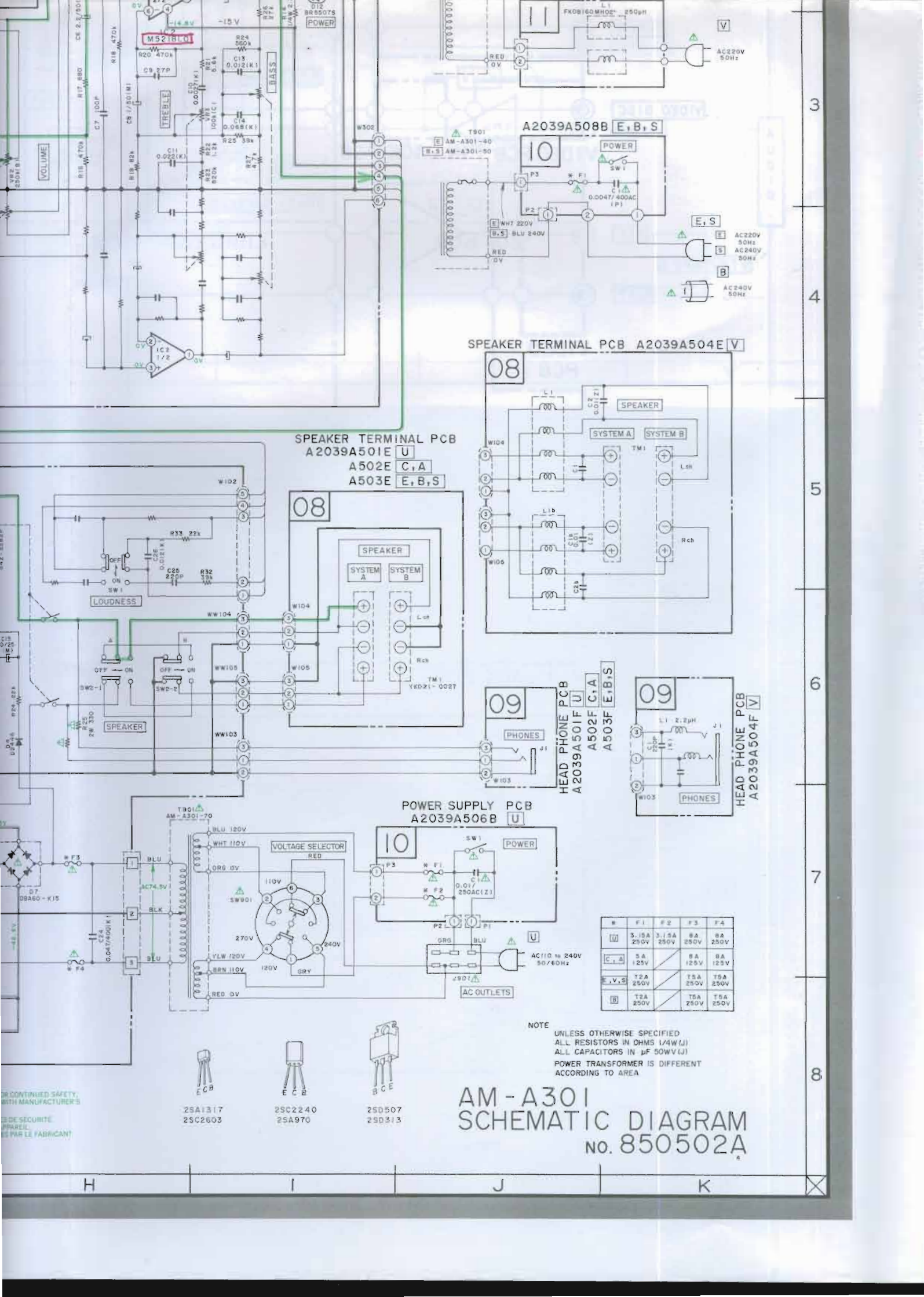

M521BL01

A2039A508B E, B, S

SPEAKER TERMINAL PCB
A2039A501E U

SPEAKER TERMINAL PCB A2039A504E V

HEAD PHONE PCB
A2039A501F U

HEAD PHONE PCB
A2039A504F V

POWER SUPPLY PCB
A2039A506B U

	F1	F2	F3	F4
U	3.15A 250V	3.15A 250V	8A 250V	8A 250V
C, A	5A 125V		8A 125V	8A 125V
E, V, S	T2A 250V		T5A 250V	T5A 250V
B	T2A 250V		T5A 250V	T5A 250V

NOTE
UNLESS OTHERWISE SPECIFIED
ALL RESISTORS IN OHMS (1/4W (J))
ALL CAPACITORS IN μ F (50WV (J))
POWER TRANSFORMER IS DIFFERENT
ACCORDING TO AREA

AM-A301
SCHEMATIC DIAGRAM
No. 850502A

2SA1317
2SC2603

2SC2240
2SA970

2SD507
2SD513

FOR CONTINUED SAFETY,
READ MANUFACTURER'S
INSTRUCTIONS.
POUR LA SÉCURITÉ
DU PARALLÈLE,
LIRE LE FABRICANT.

H I J K

3
4
5
6
7
8

AM - A301

EQUALIZER PCB A2039A501B U A2039A502B C, A
 A2039A503B E, B, S A2039A504B V

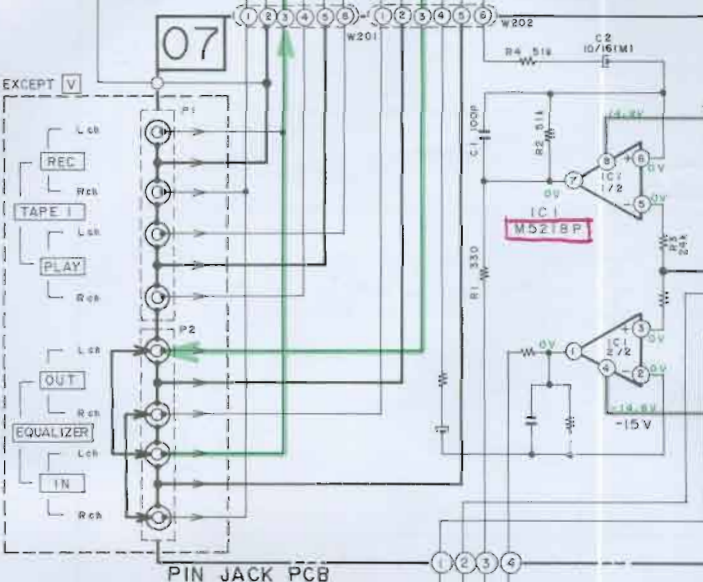
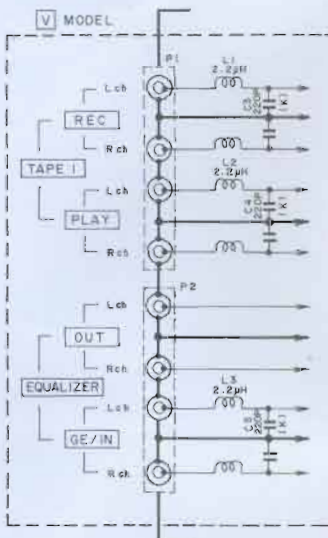
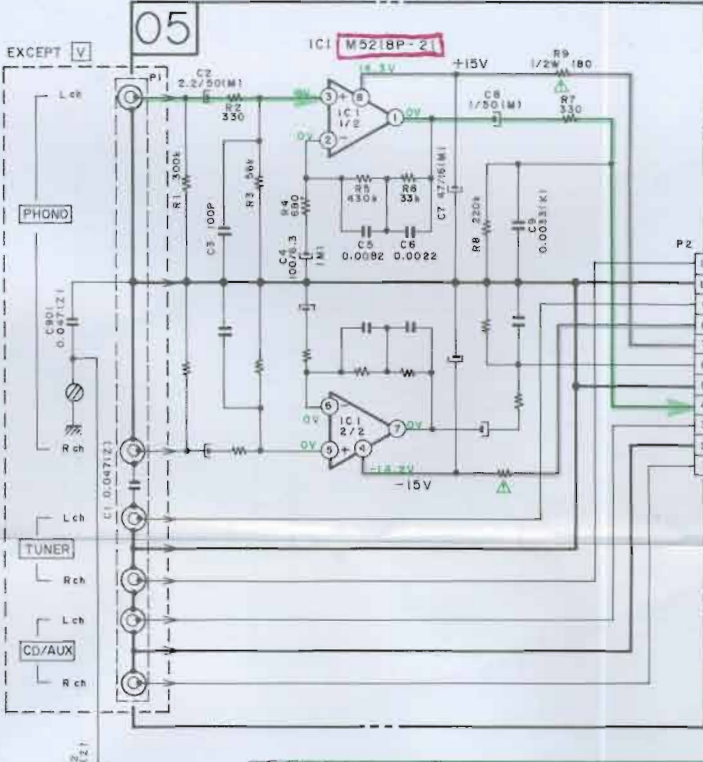
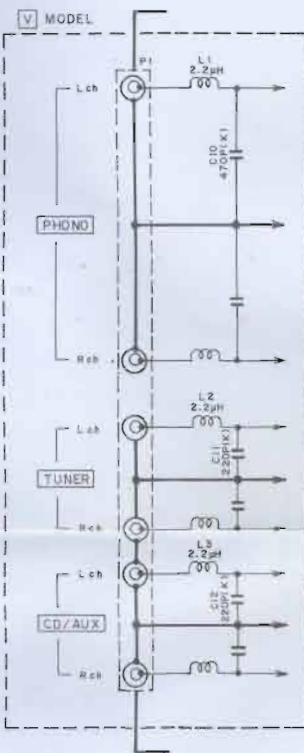

PIN JACK PCB
 A2039A501D U
 A502D C, A
 A503D E, B, S
 A504D V

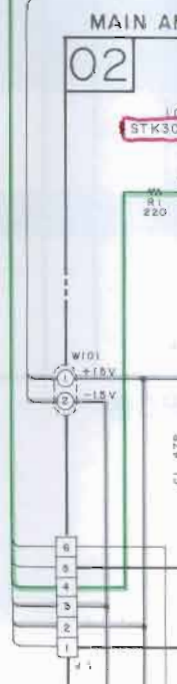
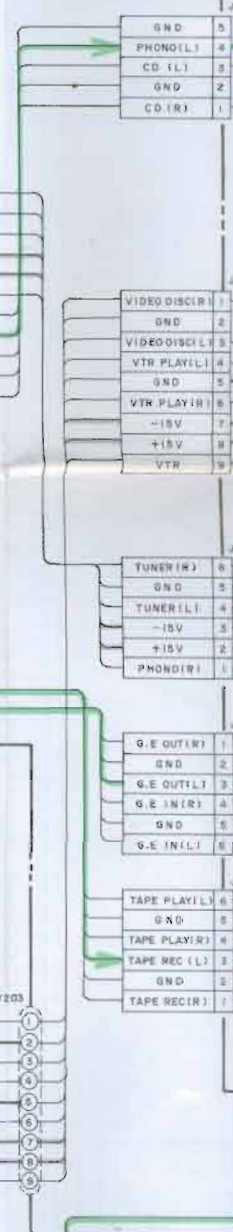
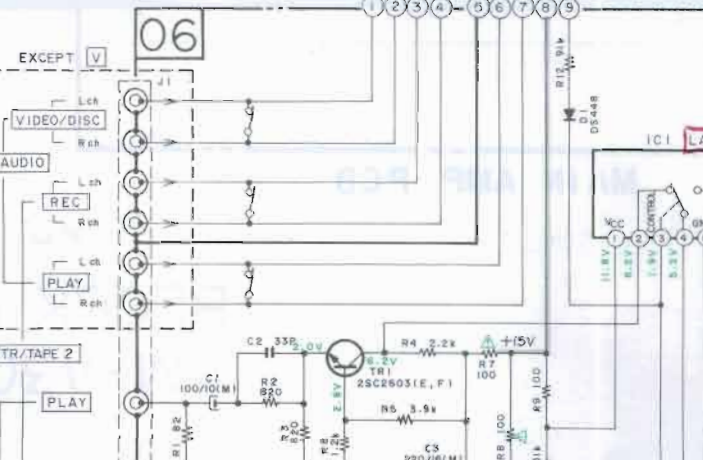
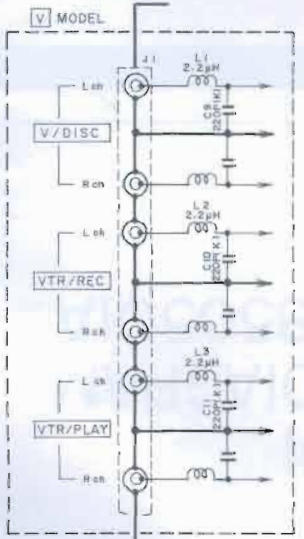

FUNCTION PCB A2039A5100 U,C,A,E,B,S,V

CONTROL PCB A2039A506A U A2039A508A E,B,S

04

03

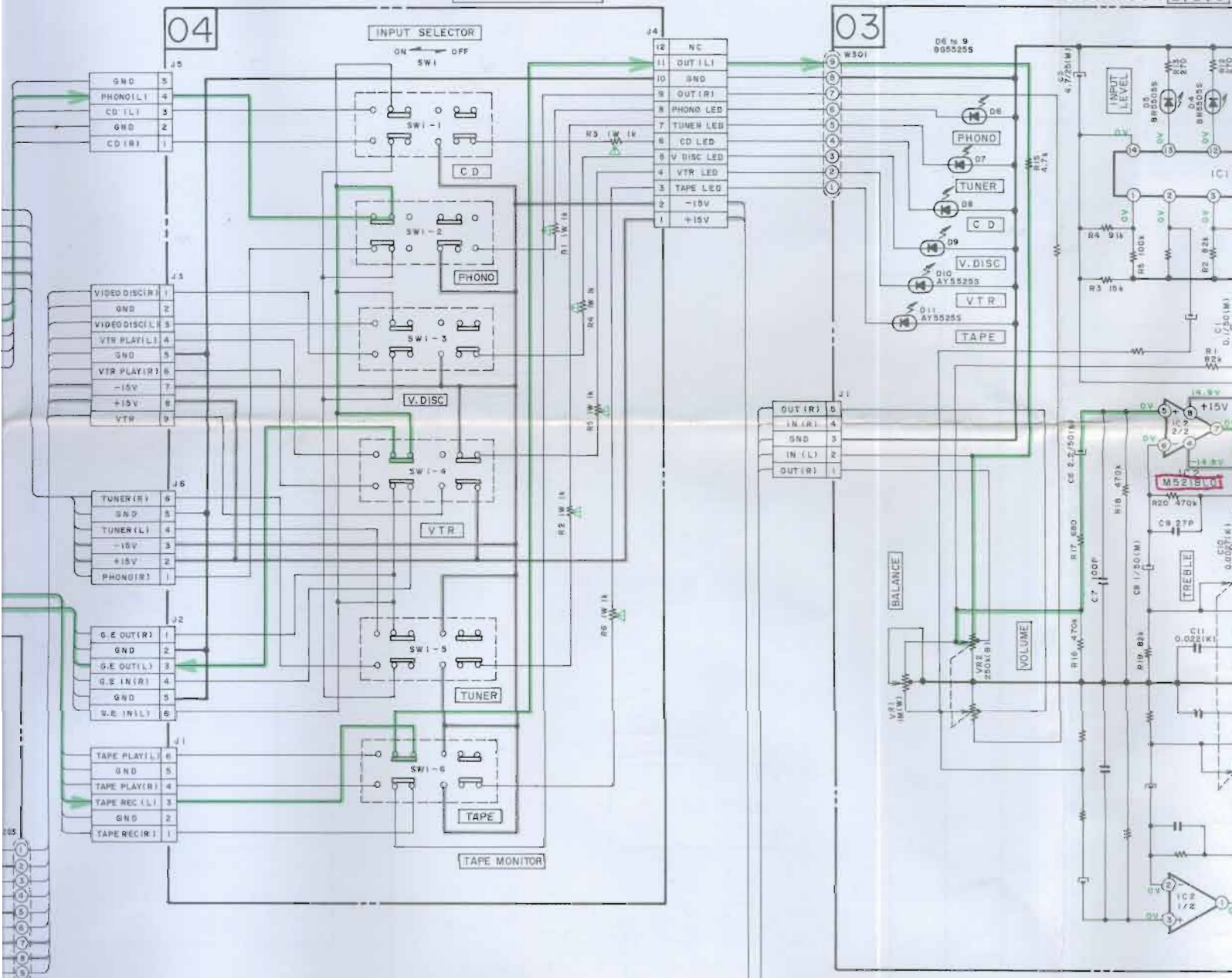

MAIN AMP PCB A2039A501A U A2039A502A C,A A2039A503A E,B,S A2039A504A V

02

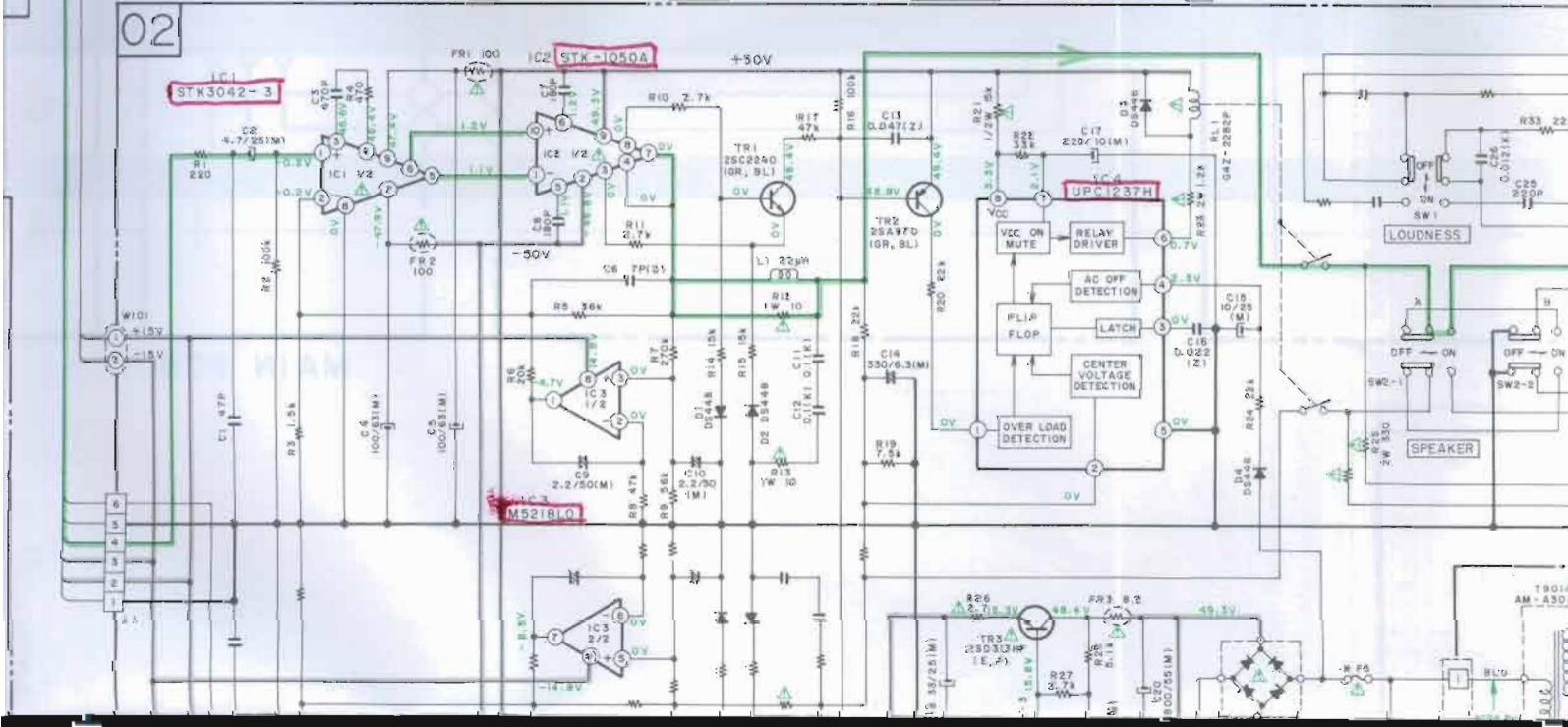

PCB A2039A506A U A2039A507A C, A
 A2039A508A E, B, S A2039A509A V

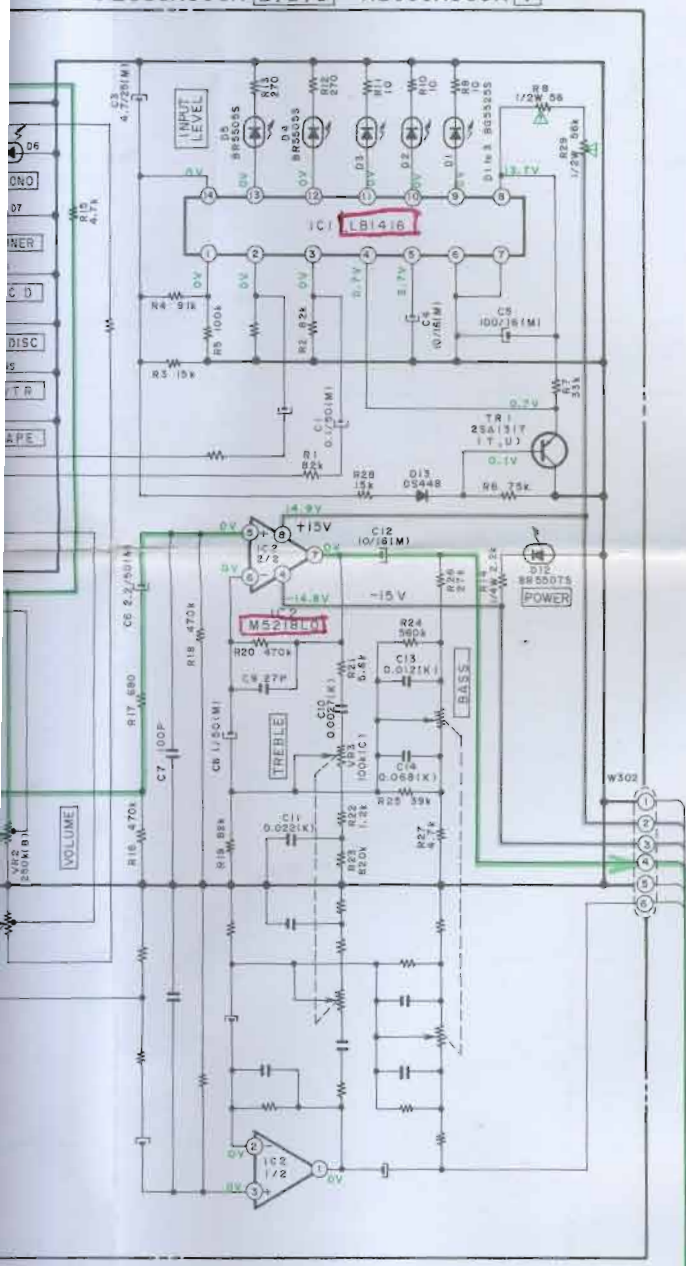

POWER SUPPLY PCB
 A2039A507B C, A

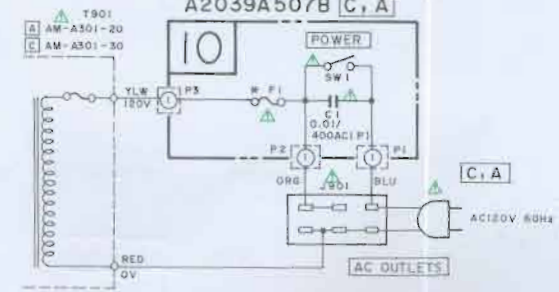

POWER SUPPLY PCB
 A2039A509B V

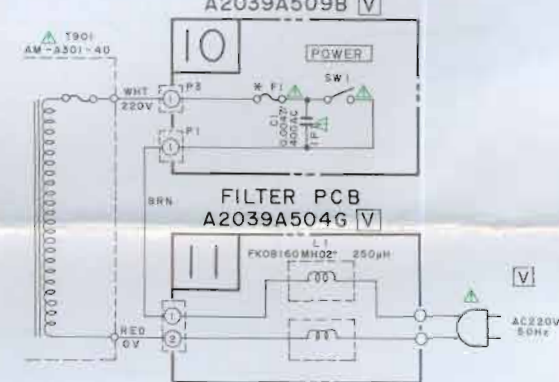

FILTER PCB
 A2039A504G V

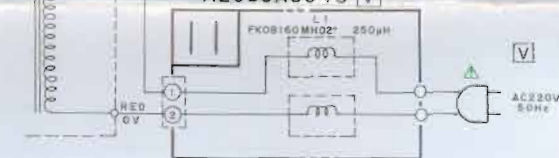

A2039A508B E, B, S

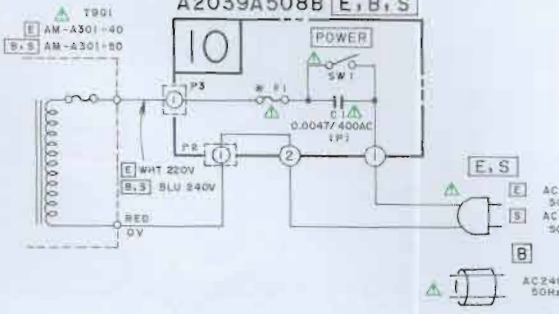

SPEAKER TERMINAL PCB A2039A504E V

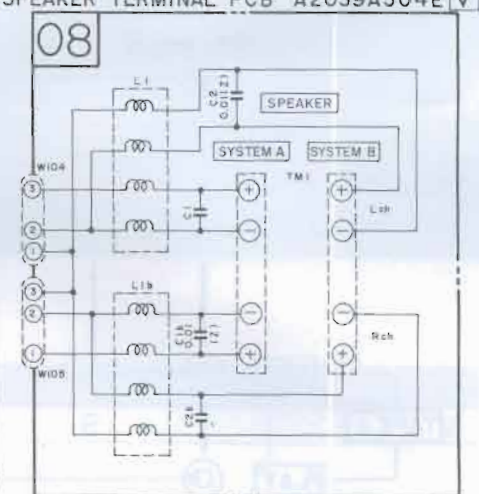

SPEAKER TERMINAL PCB
 A2039A501E U

A502E C, A
 A503E E, B, S

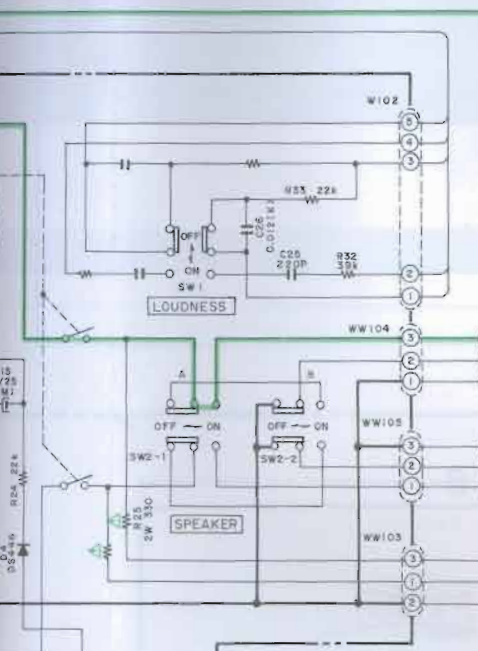
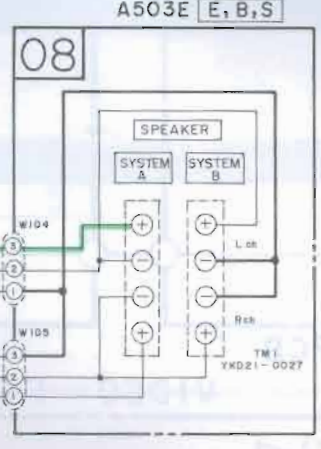

HEAD PHONE PCB
 A2039A501F U

A502F C, A
 A503F E, B, S

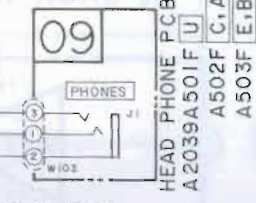

HEAD PHONE PCB
 A2039A504F V

A2039A504F V

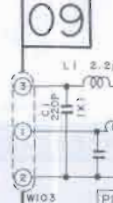

POWER SUPPLY PCB
 A2039A506B U

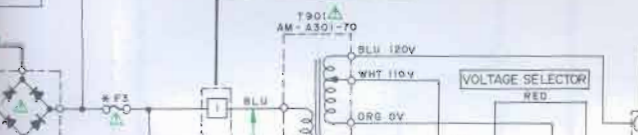

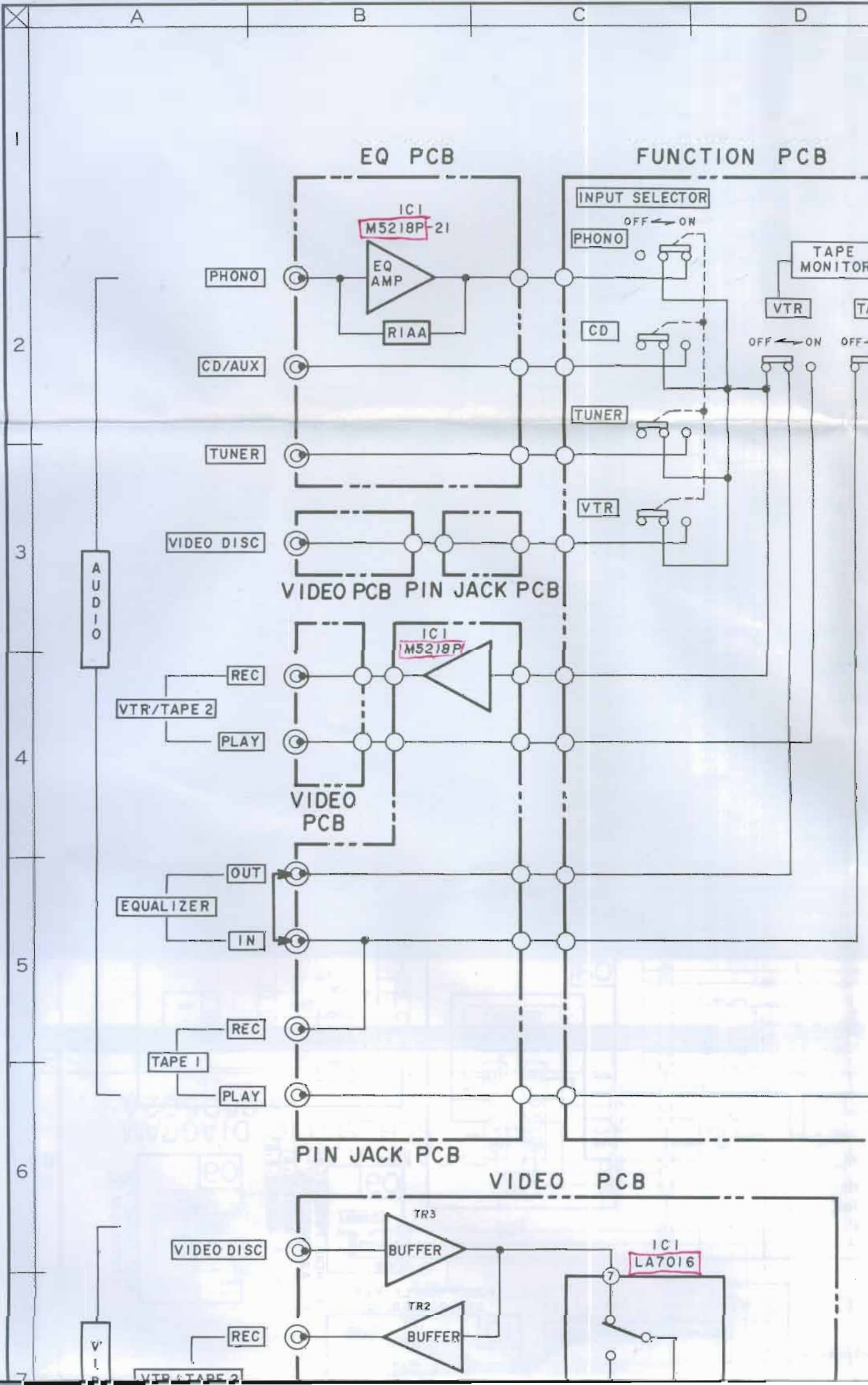

CONTROL PCB

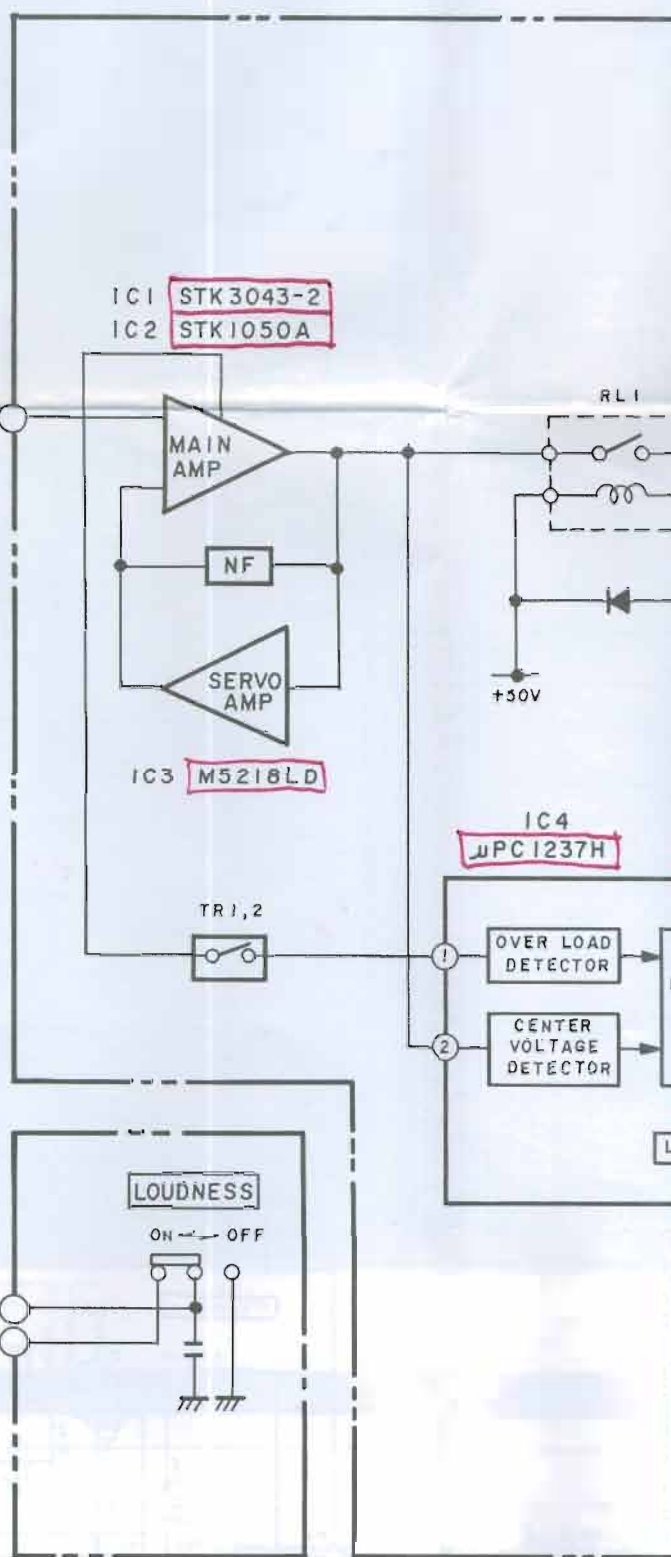
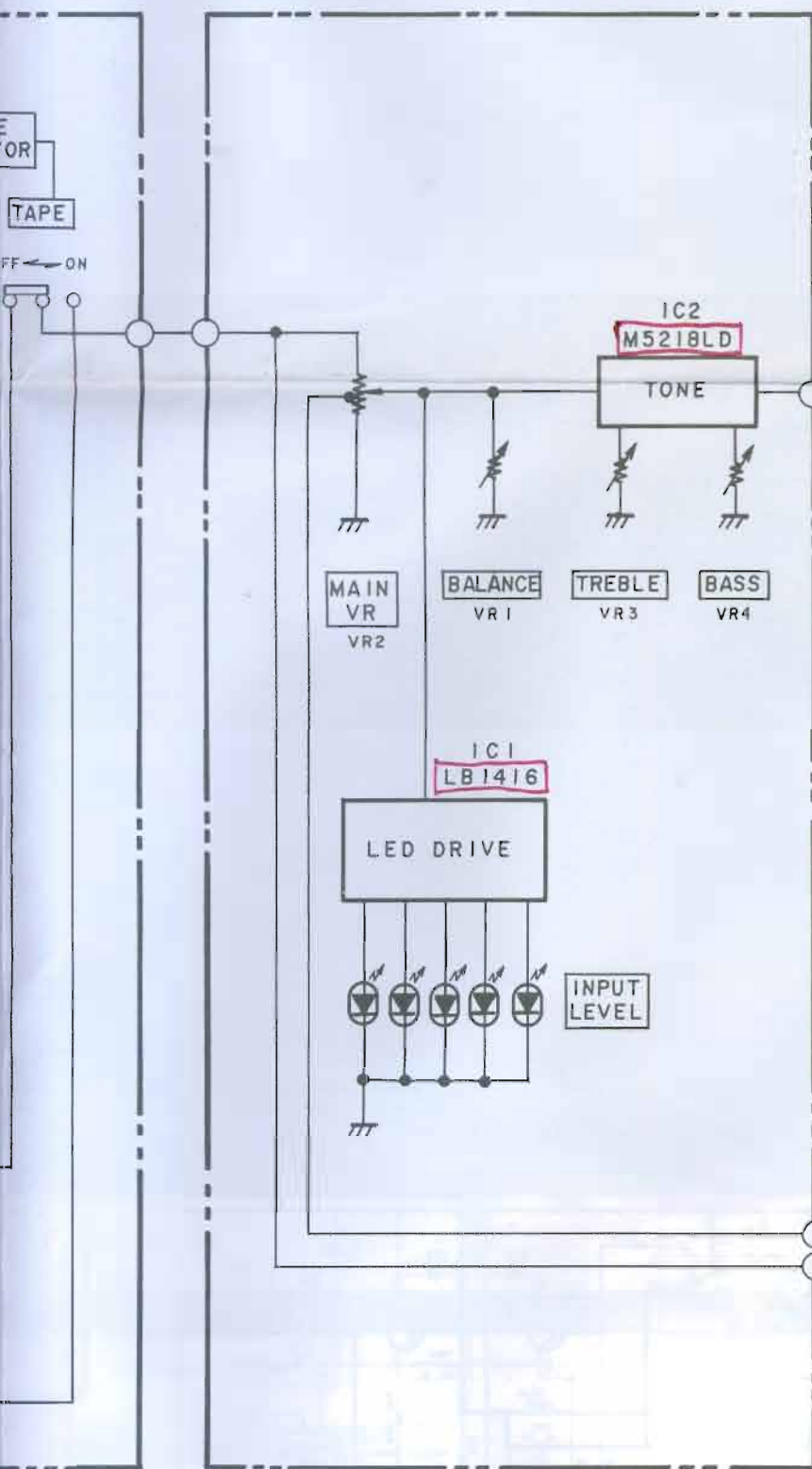

MAIN PCB

M

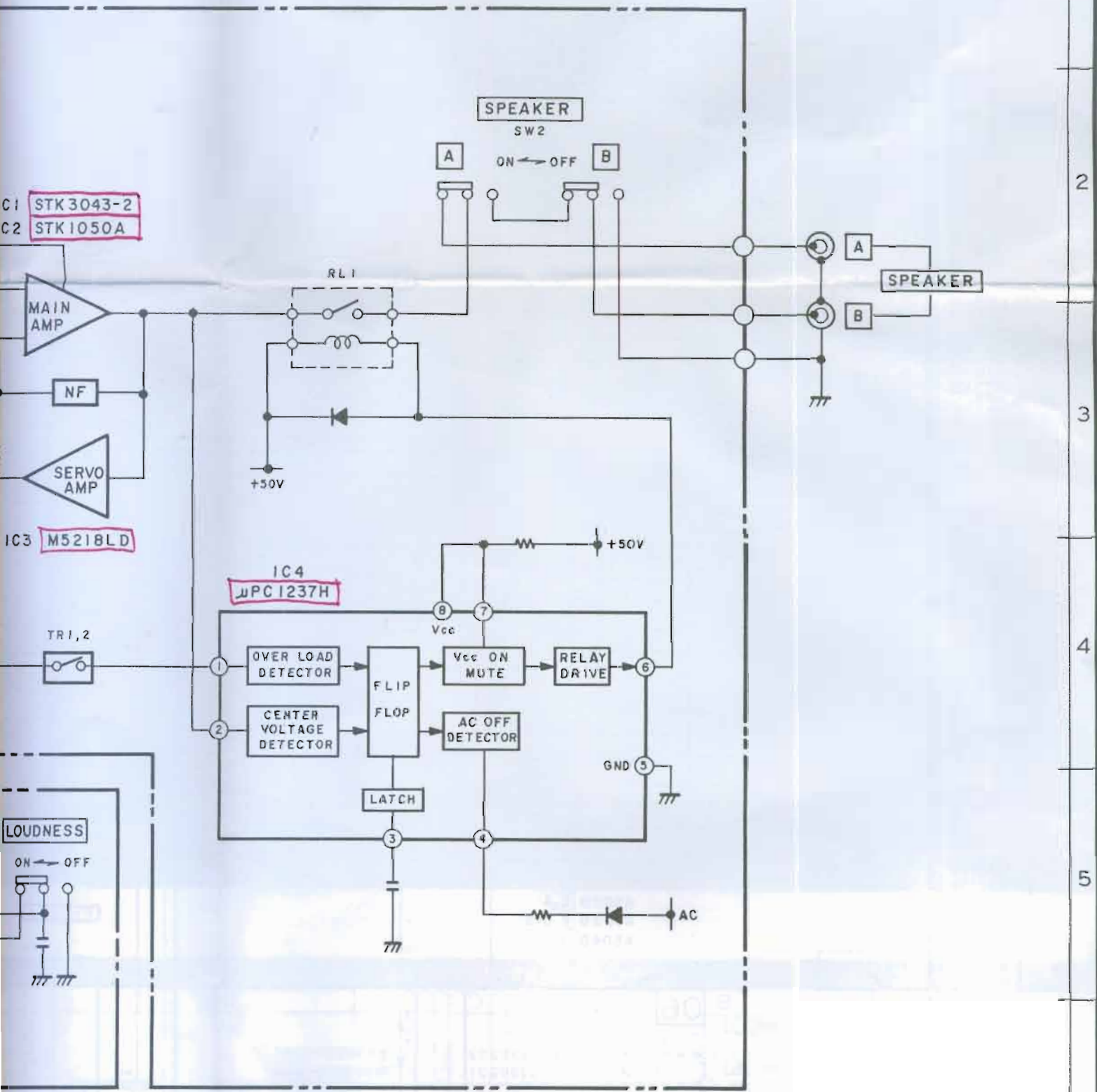

MAIN PCB

MAIN AMP PCB

1
2
3
4
5
6
7

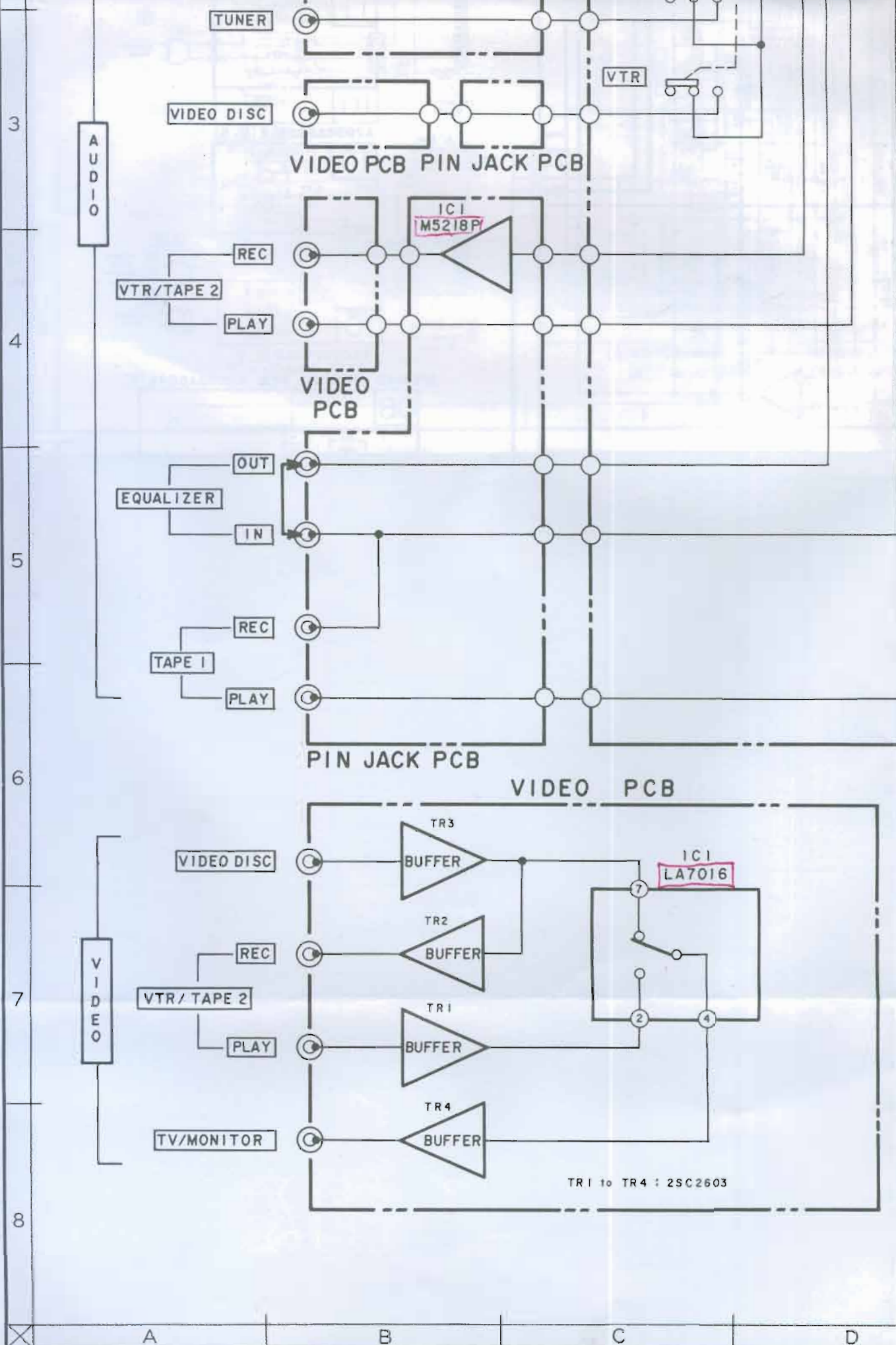

A
U
D
I
O

V
I
D
E
O

TUNER

VIDEO DISC

VTR

VIDEO PCB PIN JACK PCB

IC1
M5218P

REC

VTR/TAPE 2

PLAY

VIDEO PCB

OUT

EQUALIZER

IN

REC

TAPE 1

PLAY

PIN JACK PCB

VIDEO PCB

VIDEO DISC

TR3

BUFFER

IC1
LA7016

TR2

BUFFER

VTR/TAPE 2

REC

PLAY

TR1

BUFFER

TV/MONITOR

TR4

BUFFER

TR1 to TR4 : 2SC2603

A

B

C

D

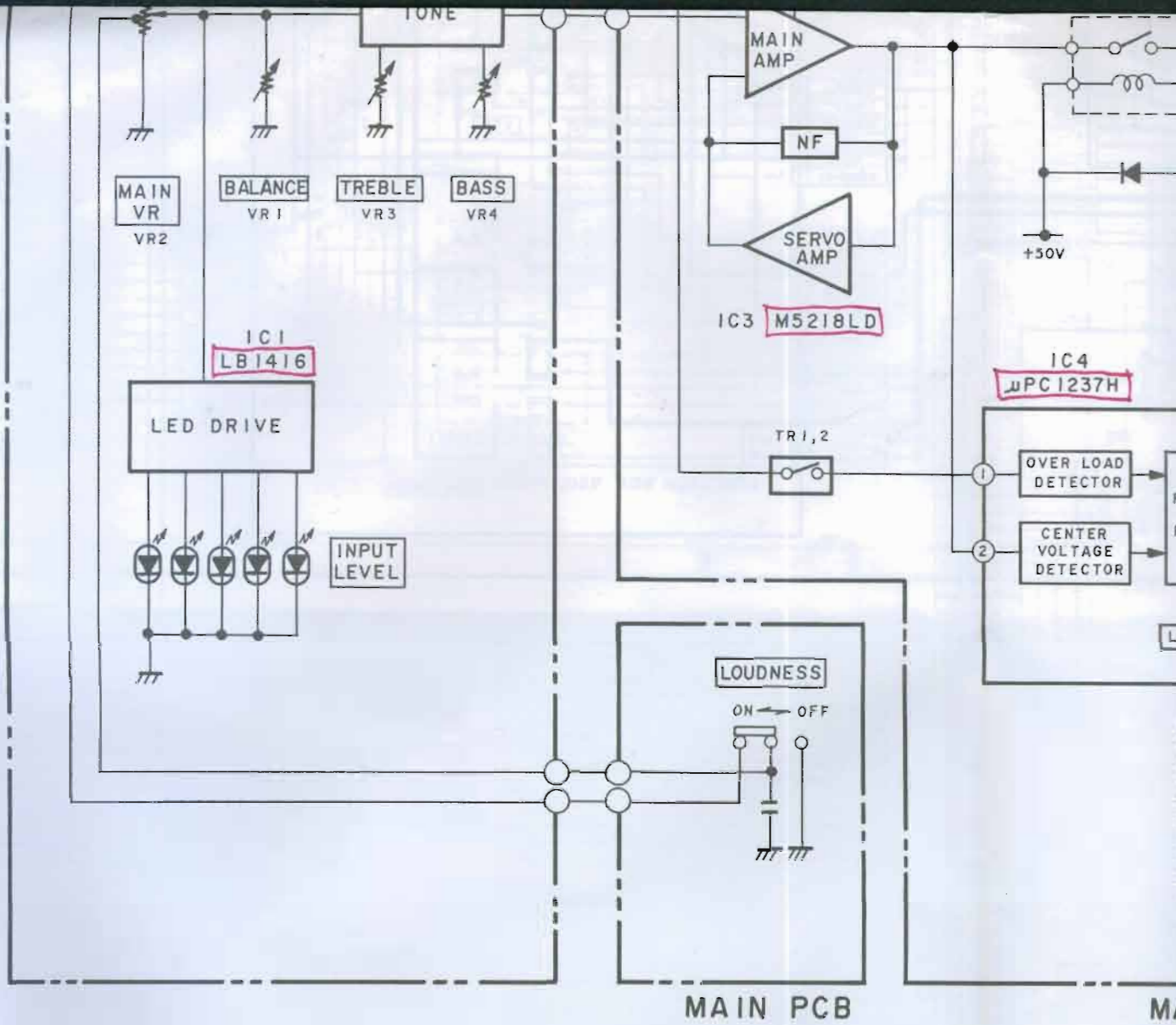

MAIN PCB

M

E

F

G

H

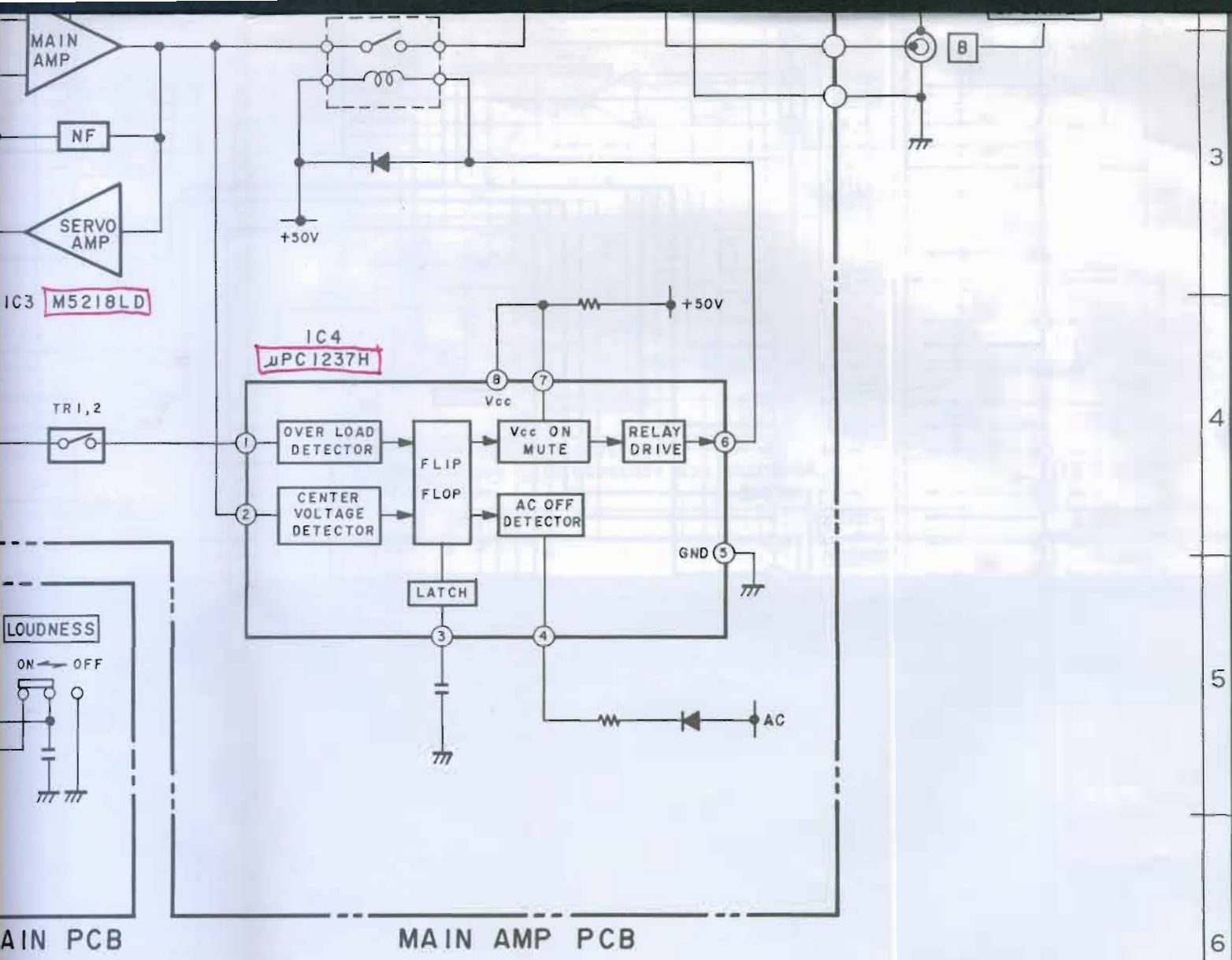

AM-A301
 BLOCK DIAGRAM
 No. 850501A (A2)

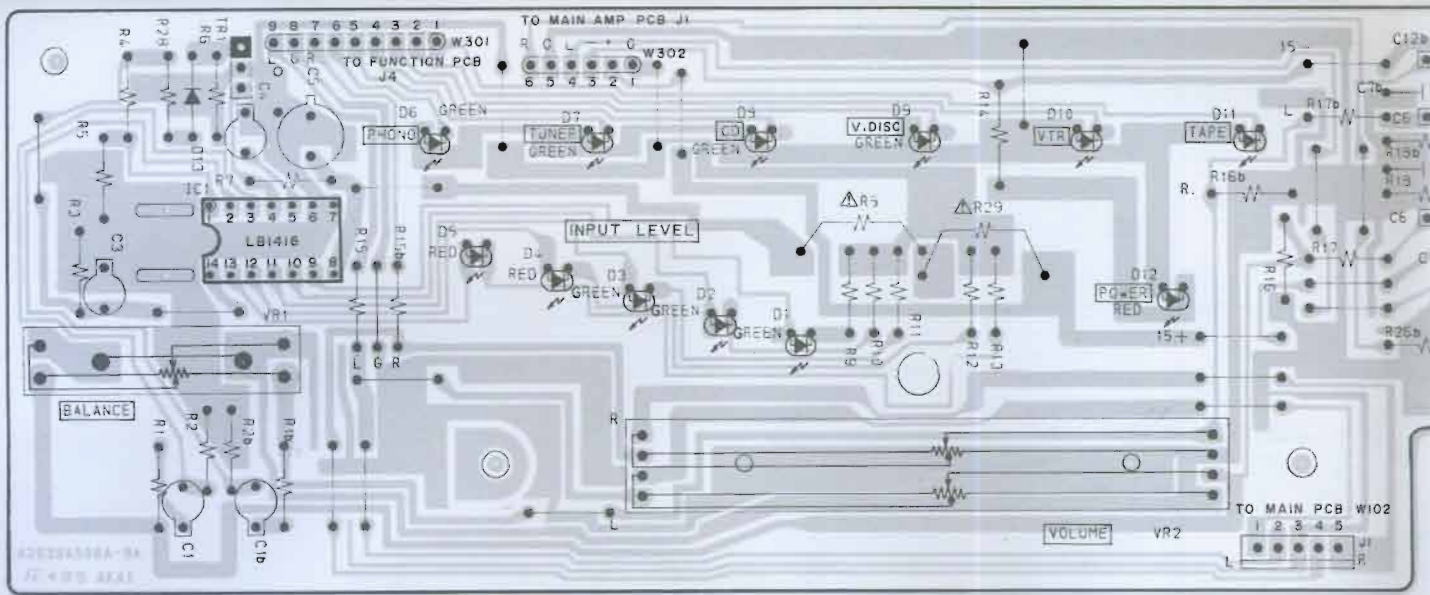

- CONTROL PCB A2039A506A
- 507A C.A
 - 508A E.B.S
 - 509A V

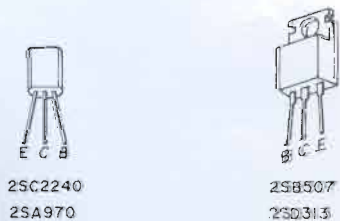
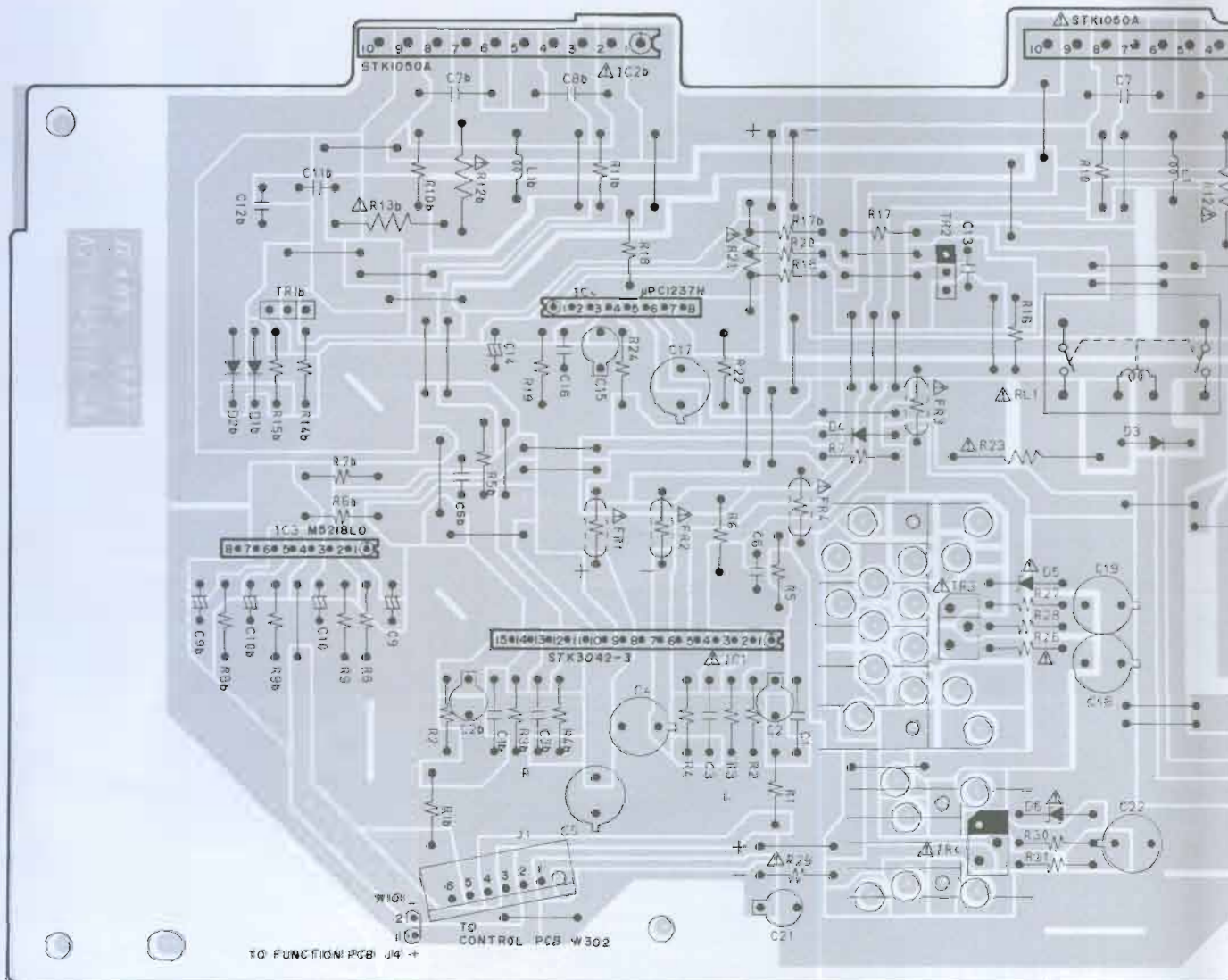

= PNP TRANSISTOR

= NPN TRANSISTOR

TR1, 1b ... 2SC2240 (GR, BL)

TR2, 2b ... 2SA970 (GR, BL)

TR3 ... 2SD313HP (E, F)

TR4 ... 2SB507HP (E, F)

MAIN AMP PCB

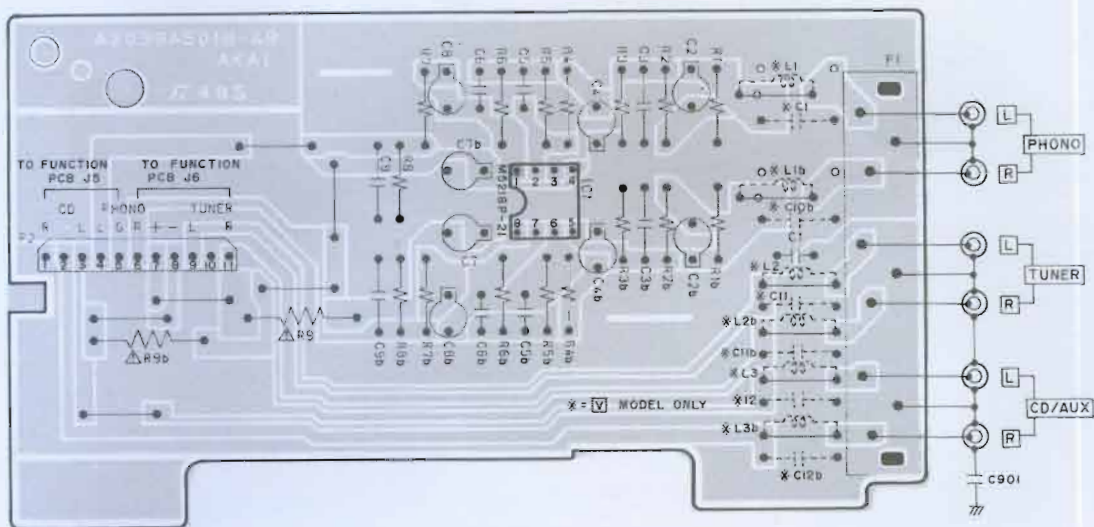

EQUALIZER PCB A2039A501B U
 502B C.A
 503B E.B.S
 504B V

PIN JACK PCB A2039A501D U
 502D C.A
 503D E.B.S
 504D V

VIDEO PCB A2039A501C U
 502C C.A
 503C E.B.S
 504C V

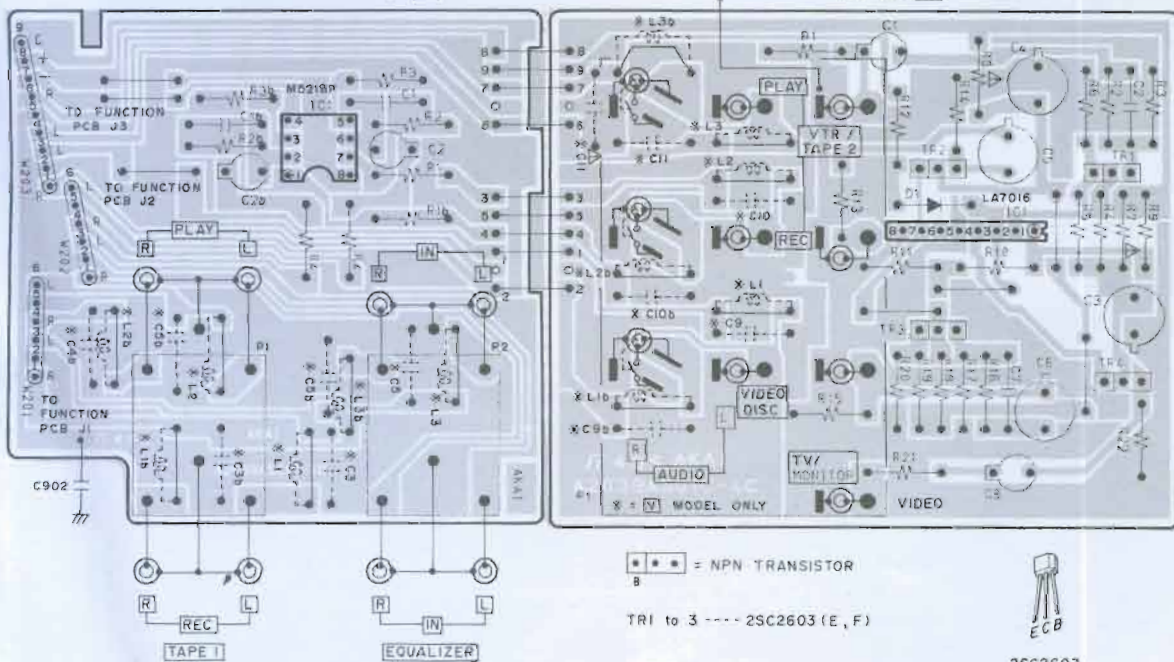

□ = NPN TRANSISTOR

TRI to 3 --- 2SC2603 (E, F)

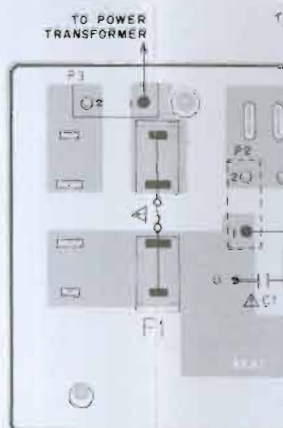
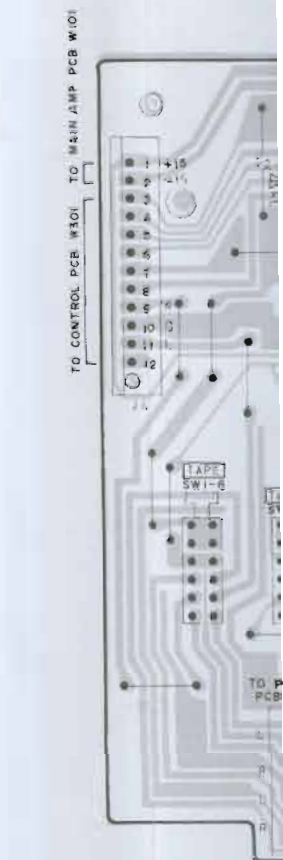

POWER SUPPLY A2039A501

TO CONTROL PCB W301 TO MAIN AMP PCB W101

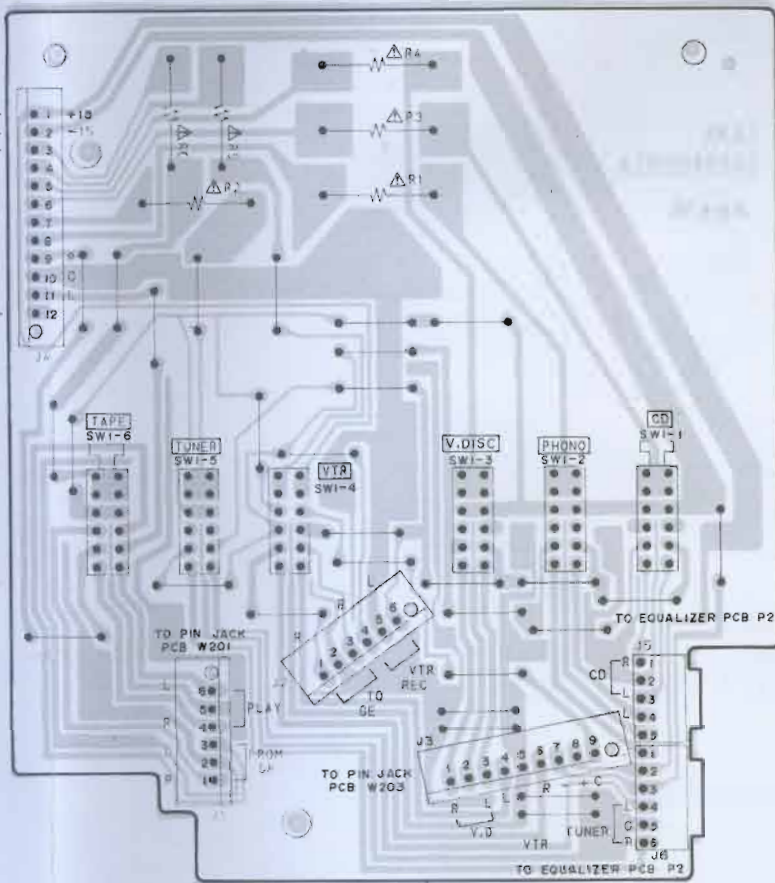

FUNCTION PCB A2039A5001

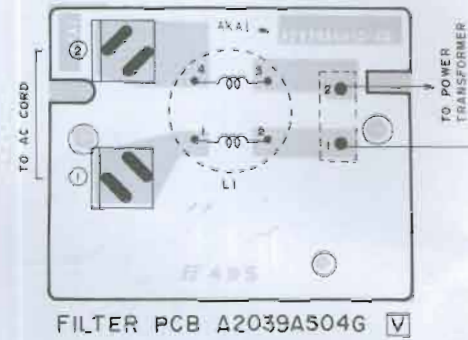

FILTER PCB A2039A504G [V]

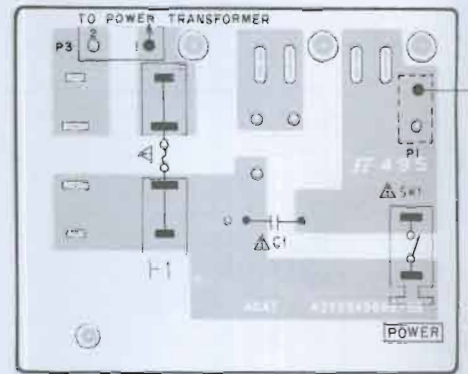

POWER SUPPLY PCB A2039A509B [V]

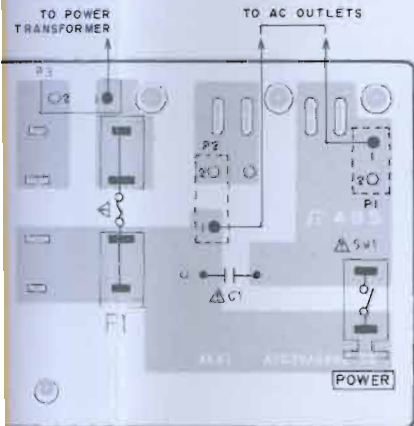

POWER SUPPLY PCB A2039A507B [A.C]

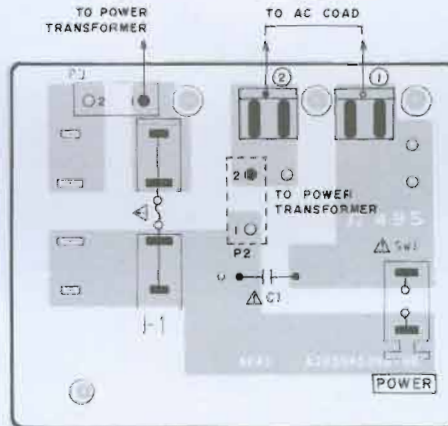

POWER SUPPLY PCB A2039A508B [E.B.S]

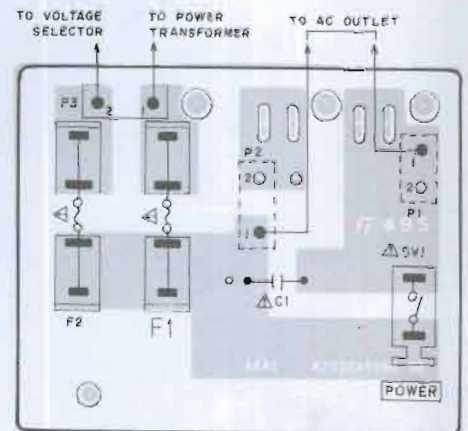

POWER SUPPLY PCB A2039A506B [U]

WARNING: Δ INDICATES SAFETY CRITICAL COMPONENTS. FOR CONTINUED SAFE OPERATION, REPLACE SAFETY CRITICAL COMPONENTS ONLY WITH MANUFACTURER RECOMMENDED PARTS.

AVERTISSEMENT: Δ IL INDIQUE LES COMPOSANTS CRITIQUES DE SÉCURITÉ. POUR MAINTENIR LE DEGRÉ DE SÉCURITÉ DE L'APPAREIL, NE REMPLACER QUE DES PIÈCES RECOMMANDÉES PAR LE FABRICANT.

AKAI ELECTRIC CO., LTD.

12-14, 2-Chome, Higashi-Kojiya, Ohta-Ku, Tokyo, Japan
TEL: Tokyo (742) 5111, CABLE: HIFIAKAI TOKYO, TELEX: J26261
Printed No. 850515-K1-3400 Printed Date: June 10, 1985

350 Printed in Japan