

# AKAI SERVICE MANUAL

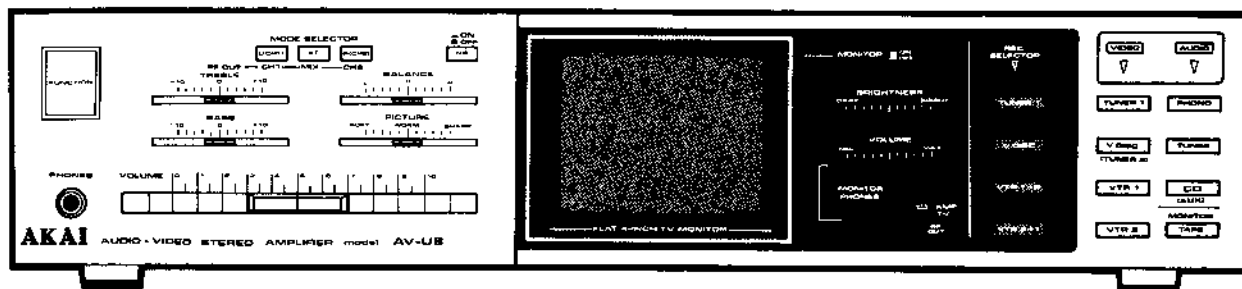

AUDIO-VIDEO STEREO AMPLIFIER

MODEL **AV-U8** EA/EK/S/EO/U/J

**ABBREVIATIONS FOR SERVICE MANUAL  
MODEL AV-U8EA/EK/S/EO/U/J**

Abbreviation	Explanation
AC	Alternating Current
ADJ	ADJustment
ANT	ANTenna
A/V	Audio/Video
CD	Compact Disc
CH	CHannel
CRT	Cathode Ray Tube
DNR	Dynamic Noise Reduction
DY	Deflection Yoke
H	High or Horizontal
PCB	Printed Circuit Board
RF	Radio Frequency
RIAA	Record Industrial Association of America
SP	SPeaker
SW	SWitch
T. H. D	Total Harmonic Distortion
TV	TeleVision
UHF	Ultra High Frequency
V	Volt or Vertical
V. DISC	Video DISC
VHF	Very High Frequency
VTR	Video Tape Recorder

# AKAI SERVICE MANUAL

## (ADDITIONAL)

\* This additional service manual is made for the new model AV-U8EK (Black Version) which employs A/V REC Source Switch.

Use this manual together with the AV-U8 Service Manual published previously.

## MODEL AV-U8EK (BLACK)

### [THE DIFFERENCE BETWEEN EACH MODEL]

MODEL NAME	(SEE NOTE 1) TV/AMP SWITCH	(SEE NOTE 2) A/V REC SOURCE SWITCH	INTERNAL MONITOR 50/60 SWITCH	(SEE NOTE 3) REC SELECTOR AUTO SWITCH	PRINCIPAL DESTINATION
AV-U8EA	○	—	—	○	AUSTRALIA
AV-U8EK	—	—	○	○	U.K., HONG KONG
AV-U8EO	—	—	○	○	EUROPE EXCEPT U.K. and FRANCE
AV-U8S	—	—	○	○	FRANCE
AV-U8U	○	—	—	—	AMERICA, CANADA
AV-U8J	—	○	—	—	JAPAN
AV-U8EK (BLACK)	—	○	—	—	U.K.

#### Note:

##### 1. TV/Amp SWITCH

Switching of the signal from ANT IN or Modulator to RF out of VHF RF Modulator.

##### 2. A/V REC SOURCE SWITCH

Switching of Audio signal only for recording from PHONO, TUNER, or CD (AUX) to VTR1 or VTR2, and from VIDEO TUNER, VIDEO DISC, VTR1 or VTR2 to Tape.

##### 3. Auto REC SELECTOR

The signal line of TV-TUNER IN will be automatically connected to REC OUT terminal internally regardless of REC SELECTOR position when the FUNCTION SWITCH is turned off, consequently, the timer recording from TV-TUNER can be executed only by setting the timer on VTR and TV-TUNER.

### ATTENTION

1. When placing an order for parts, be sure to list the parts no., model no., and description. There are instances in which if any of this information is omitted, parts cannot be shipped or the wrong parts will be delivered.
2. Please be careful not to make a mistake in the parts no. If the parts no. is in error, a part different from the one ordered may be delivered.
3. Because parts number and parts unit supply in the Preliminary Parts List may be partially changed, please use this parts list for all future reference.

### HOW TO USE THIS PARTS LIST

1. This Parts List shows the parts that are considered necessary for repairs. Other parts, such as resistors and capacitors, are shown in the "Common List for Service Parts". Select and order such parts from the "Common List for Service Parts".
2. The Recommended Spare Parts shows those parts in the Parts List which are considered particularly important for service.
3. Parts not shown in the Parts List and "Common List for Service Parts" will not be supplied in principle.
4. How to read list

a) Mechanism Block

b) P.C Board Block

#### 2. HEAD BASE BLOCK

REF. NO.	PARTS NO.	DESCRIPTION
2-1x	BH-T2023A320A	HEAD BASE BLOCK GX-F66R
2-2	HP-H2206A010A	HEAD R/P PR4-8FU C
2-3	ZS-477876	PAN20x03STL CMT
2-4	ZS-536488	BID20x08STL CMT
2-5	ZG-402895	CS ANGLE ADJUST SPRING

SP (Service Parts) Classification

A small "x" indicates the inability to show that particular part in the Photo or Illustration.

This number corresponds with the individual parts index number in that figure

This number corresponds with the Figure Number

#### 6. SYS. CON. P.C BOARD BLOCK

REF. NO.	PARTS NO.	DESCRIPTION
6-1	BA-T2034A070A	PC SYS CON BLK GX-F44R
6-IC1	EI-324536	IC HD14049BP
6-IC2	EI-336801	IC MB8841-564M
6-IC3	EI-331661	IC SN7405N
6-IC4	EI-336725	IC M54527P
6-TR1to4	ET-200985	TR 2SC2603 F,G
6-TR5to28	ET-554657	TR 2SA733A P,Q
6-D1	ED-318292	D SILICON H 1S2473T-77 T26
6-D2to4	ED-308952	D GERMA V 1K34A-LR F07
6-D5to10	ED-318292	D SILICON H 1S2473T-77 T26
6-X1	EI-318384	OSC X'TAL NC-18C 3.579545MHZ

SP (Service Parts) Classification

This reference numbers corresponds with symbol numbers of Schematic Diagrams.

5. Both the kind of part and installation position can be determined by the Parts Number. To determine where a parts number is listed, utilize Parts Index at end of Parts List. It is necessary first of all to find the Parts Number. This can be accomplished by using the Reference Number listed at right of parts number in the Parts Index.

### WARNING

▲ INDICATES SAFETY CRITICAL COMPONENTS. FOR CONTINUED SAFETY, REPLACE SAFETY CRITICAL COMPONENTS ONLY WITH MANUFACTURER'S RECOMMENDED PARTS.

### AVERTISSEMENT

▲ IL INDIQUE LES COMPOSANTS CRITIQUES DE SECURITE. POUR MAINTENIR LE DEGRE DE SECURITE DE L'APPAREIL, NE REMPLACER QUE DES PIECES RECOMMANDEES PAR LE FABRICANT.

## X-RAY RADIATION WARNING NOTICE

### WARNING:

PARTS WHICH INFLUENCE X-RAY RADIATION IN HORIZONTAL DEFLECTION, HIGH VOLTAGE CIRCUITS AND PICTURE TUBE, ETC., ARE INDICATED BY (★) IN THE PARTS LIST.

FOR REPLACEMENT PURPOSES, USE ONLY THE TYPE SHOWN IN THE PARTS LIST.

## NOTICE D'AVERTISSEMENT DE RADIATION AUX RAYONS X

### AVERTISSEMENT:

LES PIÈCES QUI INFLUENCENT LES RAYONS X AU COURS DE LA DÉVIATION HORIZONTALE, LES CIRCUITS À HAUTE TENSION ET LE TUBE-IMAGE, ETC. SONT ACCOMPAGNÉES D'UN ASTÉRISQUE (★) DANS LE CATALOGUE DE PIÈCES DÉTACHÉES. DANS CAS D'UN REMPLACEMENT, UTILISER UNIQUEMENT LES MODÈLES DE PIÈCES INDICÉS DANS LE CATALOGUE DE PIÈCES DÉTACHÉES.

## PRODUCT SAFETY NOTICE

### WARNING:

FOR CONTINUED SAFETY, REPLACE SAFETY CRITICAL COMPONENTS ONLY WITH MANUFACTURE'S RECOMMENDED PARTS. THESE PARTS ARE IDENTIFIED BY SHADING AND BY (Δ) ON THE SCHEMATIC DIAGRAM.

## NOTICE DE SECURITE

### AVERTISSEMENT:

POUR ÊTRE ASSURÉ D'UNE SECURITE OPTIMALE À TOUT MOMENT, REMPLACER LES COMPOSANTS CRITIQUES UNIQUEMENT PAR LES PIÈCES RECOMMANDÉES PAR LE FABRICANT DE L'APPAREIL. CES PIÈCES SONT IDENTIFIÉES PAR UNE ZONE D'OMBRE ET PAR LE SYMBOLE (Δ) SUR LE SCHEMA DE MONTAGE.

Certain H V failures can increase X-ray radiation. Monitors should not be operated with H V levels exceeding the specified rating for their chassis type. The maximum operating H V specified for the chassis used in these monitor is 7.5 ± 0.5kV at Zero beam current with an input voltage of 120VAC.

Higher voltage may also increase possibility of failure in H V supply.

To determine the presence of high voltage, use an accurate, high impedance, H V meter connected between second anode lead and the C. R. T. tag grounding device. When servicing the High Voltage System, remove static charge from it by connecting a 10k ohm resistor in series with an insulated wire (such as a test probe) between picture tube tag and 2nd anode lead (AC line cord disconnected from AC supply). After servicing fix the anode cap onto picture tube and check and ensure the metal protector is surely adhered.

The picture tube used in this monitor employs integral implosion protection. Replace with tube of the same type number for continued safety.

### WARNING

- ★ MARK: X-RAY RADIATION RELATED PARTS.
- Δ MARK: SAFETY RELATED PARTS.

### AVERTISSEMENT

- MARQUE ★: PIÈCES RELATIVES AUX RADIATIONS AUX RAYONS
- MARQUE Δ: PIÈCES RELATIVES À LA SECURITE

# PARTS LIST

## RECOMMENDED SPARE PARTS LIST

Because, if the parts listed below are on hand, almost any repair can be accomplished, we suggest that you stock these Recommended Spare Parts Items.

REF. NO.	PARTS NO.	DESCRIPTION
1	BT-710676	△ TRANS POWER AV-U8EO(E), EK, S
2	BV-345125	RF MODULATOR MIW3-253
3	ED-707057	D LED TLG113A GRN
4	ED-707056	D LED TLR113A RED
5	ED-710669	D SILICON H S5295J
6	ED-604541	D SILICON H 1S2076
7	ED-306724	D SILICON S5277B 100/1.0A
8	ED-347767	D SILICON V MC911 DOUBLE
9	ED-347768	D SILICON V MC921 DOUBLE
10	ED-322238	D SILICON 1B4B41 100/1.0A
11	ED-710863	D SILICON 2B4B41
12	ED-319463	D SILICON 4B4B41 100/4.0A
13	ED-346615	D ZENER H HZ12 A2
14	N ED-346542	D ZENER H HZ9L B3
15	EF-668474	△ FUSE SEMKO T 250V 0.40A
16	EF-601964	△ FUSE SEMKO T 250V 1.60A
17	EF-623125	△ FUSE SEMKO T 250V 2.50A
18	EF-690996	△ FUSE SEMKO T 250V 4.00A
19	EF-558990	FUSE TSC B 125V 2.50A W/LEAD
20	EF-306957	△ FUSE TSC 125V 4.00A
21	EI-338406	IC LM1894N
22	EI-348785	IC M5220L
23	EI-337842	IC M5231L
24	EI-338500	IC STK461
25	EI-304657	IC TC4011BP
26	EI-332259	IC TC4052BP
27	EI-310036	IC TC4066BP
28	EI-710668	IC UPC1379C
29	EJ-712019	SOCKET CRT
30	EJ-301513	SOCKET INLET S-16453 E 2P
31	N EO-713682	★ △ COIL CA TV FLYBACK
		MSH-D637B (T401)
32	EO-710865	★ COIL CA, TV LINIER
		TB83-00161(L401)
33	EO-710666	★ △ COIL DEF CRT YS-33185 (L402)
34	EQ-710665	RELAY POWER FBR-621D012
35	ER-200972	△ R FUSE ERD2FC S10 1/4W 33R0G
36	ER-200595	△ R FUSE ERD2FC S10 1/4W 5R6J
37	N ER-328520	△ R FUSE ERD2FC 1/4W 1000G
38	ER-712036	△ R FUSE FMR 1/4W 150J
39	ER-712027	△ R FUSE FRM 1/2W 101J
40	ES-710677	△ SW SEESAW SDB1SE(SW601)
41	ES-337898	△ SW SLIDE 00120163 01-2(SW602)
42	ES-710663	SW FUNCTION SUL121S
43	ES-710648	SW PUSH SPH121A
44	ES-710654	SW PUSH SUT11A
45	ES-710655	SW PUSH SUT 32A
46	ES-710647	SW PUSH SUV32A 3-THROW
47	ES-710646	SW PUSH SUV42A 4-THROW
48	ES-710649	SW TACT EVQ-QJ104
49	N ET-307997	TR 2SA1115 D, E
50	ET-633677	TR 2SA490 O, Y
51	N ET-713674	TR 2SB1034
52	N ET-511694	TR 2SC1211 D, E
53	N ET-330464	TR 2SC2603 D, E
54	ET-308141	TR 2SC2603 G
55	N ET-713673	TR 2SD1438
56	N ET-666404	TR 2SD571 K, L
57	ET-704058	TR 2SD666A
58	ET-710667	TR 2SD763
59	EU-710861	CRT 100EB4
60	N EV-316442	R S-FIX H D8 3P 102
61	EV-315754	R S-FIX H D8 3P 204
62	EV-319381	R S-FIX H D8 3P 501
63	EV-315541	R S-FIX H D8 3P 503

REF. NO.	PARTS NO.	DESCRIPTION
64	EV-710866	VR ROTARY VE12CV 25KB103
65	EV-710659	VR SLIDE SA021 A503
66	EV-710658	VR SLIDE VJ3-13-2PVN 10C-BM 202
67	EV-710656	VR SLIDE VJ3013-2GPNV 10C-1Z 104
68	EV-710652	VR SLIDE VJ3013-2GPNV 10C-15A 502
69	EV-710657	VR SLIDE VJ3013-2GPNV 10C-15Z 104
70	EV-710653	VR SLIDE VJ3013-2PVN 10C-15A 504

“NOTE” N: New Parts

## 1. PC BOARD BLOCK

REF. NO.	PARTS NO.	DESCRIPTION
1-1	BA-713679	PC VIDEO BLK AV-U8EK-B
1-2	BA-713675	PC POWER & MAIN BLK AV-U8EK-B
1-3	BA-713684	PC AUDIO BLK AV-U8EK-B

### NOTES:

- 1) PC VIDEO BLK consists of VIDEO PCB, MONITOR PCB, and FILTER PCB.
- 2) PC POWER & MAIN BLK consists of POWER & MAIN PCB, MAIN VOLUME PCB, FUNCTION PCB, TONE CONTROL PCB, and SPEAKER PCB.
- 3) PC AUDIO BLK consists of AUDIO PCB, CONTROL PCB, JUCK PCB, and MUTE PCB.

## 2. VIDEO PC BOARD BLOCK

REF. NO.	PARTS NO.	DESCRIPTION
2-IC301	EI-348785	IC M5220L
2-IC302	EI-332259	IC TC4052BP
2-Q301 to 308	ET-330464	TR 2SC2603 D, E
2-Q309 to 316	ET-307997	TR 2SA1115 D, E
2-Q317	ET-330464	TR 2SC2603 D, E
2-Q318	ET-307997	TR 2SA1115 D, E
2-Q319, 320	ET-511694	TR 2SC1211 D, E
2-Q321	ET-307997	TR 2SA1115 D, E
2-Q322, 323	ET-330464	TR 2SC2603 D, E
2-Q324	ET-511694	TR 2SC1211 D, E
2-D301 to 308	ED-347768	D SILICON V MC921 DOUBLE
2-D309, 310	ED-347767	D SILICON V MC911 DOUBLE
2-VR301	EV-316442	R S-FIX H D8 3P 102
2-L307	EO-419624	COIL FIX 1 FL05H 470K
2-R325 to 328	ER-200972	△ R FUSE ERD2FC S10 1/4W 33R0G
2-R358	ER-200972	△ R FUSE ERD2FC S10 1/4W 33R0G
2-R360	ER-200972	△ R FUSE ERD2FC S10 1/4W 33R0G
2-R383	ER-200972	△ R FUSE ERD2FC S10 1/4W 33R0G
2-J3A	EJ-712030	PIN J YKB11-0101 1P
2-J3B	EJ-712031	PIN J YKC21-5067 3P
2-J3C	EJ-713678	JACK PLATE YKC21-0081 6P

## 3. POWER & MAIN PC BOARD BLOCK

REF. NO.	PARTS NO.	DESCRIPTION
3-IC211	EI-338500	IC STK461
3-IC212	EI-337842	★ IC M5231L
3-Q211	ET-633677	TR 2SA490 O, Y
3-Q212	ET-713673	TR 2SD1438
3-Q213	ET-713674	TR 2SB1034
3-Q214	ET-307997	TR 2SA1115 D, E
3-Q215, 216	ET-330464	TR 2SC2603 D, E
3-D201 to 203	ED-604541	D SILICON H 1S2076
3-D204	ED-319463	D SILICON 4B4B41 100/4.0A
3-D205	ED-710863	D SILICON 2B4B41
3-D206	ED-322238	D SILICON 1B4B41 100/1.0A
3-D207	ED-604541	D SILICON H 1S2076
3-D209, 210	ED-346542	D ZENER H HZ9L B3
3-D211	ED-604541	D SILICON H 1S2076
3-RY201	EQ-710665	RELAY POWER FBR-621D012
3-R269	ER-712027	△ R FUSE FRM 1/2W 101J
3-R278, 279	ER-710862	△ R CT RGC-3 R33J
3-R280, 281	ER-333015	△ R OMF H SNP FS 2W 4R7J
3-R288	ER-328480	△ R OMF H SNP FS 1W 271J
3-R289	ER-315972	★ R CB V CUT RDS 1/4W 223J
3-R290	ER-315982	★ R CB V CUT RDS 1/4W 332J
3-C269, 270	EC-337962	C EC V CUT SM 472M 35.0DC
3-C273	EC-343382	C EC V CUT SM 682M 45.0DC
3-F203, 204	EF-623125	△ FUSE SEMKO T 250V 2.50A
3-F205, 206	EF-690996	△ FUSE SEMKO T 250V 4.00A
3-F207	EF-601964	△ FUSE SEMKO T 250V 1.60A
3-F208, 209	EF-668474	△ FUSE SEMKO T 250V 0.40A

## 4. AUDIO PC BOARD BLOCK

REF. NO.	PARTS NO.	DESCRIPTION
4-IC101 to 103	EI-332259	IC TC4052BP
4-IC104	EI-304657	IC TC4011BP
4-Q101 to 104	ET-308141	TR 2SC2603 G
4-Q105 to 109	ET-330464	TR 2SC2603 D, E
4-Q110	ET-307997	TR 2SA1115 D, E
4-Q111	ET-330464	TR 2SC2603 D, E
4-D101 to 107	ED-604541	D SILICON H 1S2076
4-J1A	EJ-712040	PIN J YKC21-0008 2P
4-J1B	EJ-712041	PIN J YKC21-0018 4P
4-J1C	EJ-712042	PIN J YKC21-0019 6P

## 5. CONTROL PC BOARD BLOCK

REF. NO.	PARTS NO.	DESCRIPTION
5-Q161	ET-330464	TR 2SC2603 D, E
5-Q162	ET-307997	TR 2SA1115 D, E
5-Q163	ET-330464	TR 2SC2603 D, E
5-Q164 to 167	ET-307997	TR 2SA1115 D, E
5-Q168	ET-330464	TR 2SC2603 D, E
5-D161 to 172	ED-604541	D SILICON H 1S2076
5-D174 to 178	ED-604541	D SILICON H 1S2076
5-D180 to 182	ED-604541	D SILICON H 1S2076
5-D184	ED-707056	D LED TLR113A RED
5-D185	ED-707057	D LED TLG113G GRN
5-D186	ED-707056	D LED TLR113A RED
5-SW161, 162	ES-710646	SW PUSH SUV42A 4-THROW
5-SW163	ES-710647	SW PUSH SUV32A 3-THROW
5-SW164, 165	ES-710648	SW PUSH SPH121A
5-SW166, 167	ES-710649	SW TACT EVQ-QJ104
5-VR161	EV-710652	VR SLIDE VJ3013-2GPVN 10C-15A 502
5-VR162	EV-710653	VR SLIDE VJ3013-2PVN 10C-15A 504

## 6. MONITOR PC BOARD BLOCK

REF. NO.	PARTS NO.	DESCRIPTION
6-IC401	EI-710668	IC UPC1379C
6-Q401	ET-330464	TR 2SC2603 D, E
6-Q402	ET-704058	TR 2SD666A
6-Q403	ET-330464	TR 2SC2603 D, E
6-Q404	ET-710667	TR 2SD763
6-Q405	ET-511694	TR 2SC1211 D, E
6-D401 to 403	ED-710669	D SILICON H S5295J
6-D404	ED-306724	D SILICON S5277B 100/1.0A
6-D405	ED-604541	D SILICON H 1S2076
6-D406	ED-710669	D SILICON H S5295J
6-D407, 408	ED-604541	D SILICON H 1S2076
6-VR401	EV-316442	R S-FIX H D8 3P 102
6-VR402	EV-315541	R S-FIX H D8 3P 503
6-VR403	EV-710866	VR ROTARY VE12CV 25KB103
6-VR404	EV-319381	R S-FIX H D8 3P 501
6-VR406	EV-315754	R S-FIX H D8 3P 204
6-L401	EO-710865	★ Δ COIL CA, TV LINIER TB83-00161
6-L404	EO-200602	COIL FIX 1 FL05H 561K
6-T401	EO-713682	★ Δ COIL CA TV FLYBACK MSH-D637B
6-R452	ER-328520	Δ R FUSE ERD2FC 1/4W 1000G
6-R453	ER-200595	Δ R FUSE ERD2FC S10 1/4W 5R6J
6-R454	ER-712036	★ Δ R FUSE FMR 1/4W 150J
6-C419	EC-318377	C TT V D 1R0M 35DC
6-C425	EC-712037	★ C MMY DTW 562J 100DC
6-C426	EC-713681	★ C MMY DTW 822J 100DC
6-C427	EC-712039	★ C MMY DTW 182J 100DC
6-C431	EC-200947	★ C EC V CUT SM 331 35.0DC

## 7. MAIN VOLUME PC BOARD BLOCK

REF. NO.	PARTS NO.	DESCRIPTION
7-IC201	EI-338406	IC LM1894N
7-Q221, 222	ET-307997	TR 2SA1115 D, E
7-Q223	ET-330464	TR 2SC2603 D, E
7-Q224	ET-307997	TR 2SA1115 D, E
7-VR205	EV-710659	VR SLIDE SA021 A503

## 8. TONE CONTROL PC BOARD BLOCK

REF. NO.	PARTS NO.	DESCRIPTION
8-IC202	EI-348785	IC M5220L
8-Q201, 202	ET-330464	TR 2SC2603 D, E
8-SW201	ES-710654	SW PUSH SUT11A
8-SW202	EA-710655	SW PUSH SUT32A
8-VR201	EV-710656	VR SLIDE VJ3013-2GPVN 10C-1Z 104
8-VR202, 203	EV-710657	VR SLIDE VJ3013-2GPVN 10C-1SZ 104
8-VR204	EV-710658	VR SLIDE VJ3013-2GPVN 10C-BM 202

## 9. SPEAKER PC BOARD BLOCK

REF. NO.	PARTS NO.	DESCRIPTION
9-J296	EJ-710660	TERMINAL SPEAKER YKD21-0007 4P
9-F201, 202	EF-558990	FUSE TSC B 125V 2.50A W/LEAD

## 10. FUNCTION PC BOARD BLOCK

REF. NO.	PARTS NO.	DESCRIPTION
10-SW291	ES-710663	SW FUNCTION SUL121S
10-J291	EJ-710645	PHONE J YKB21-5066

## 11. JACK PC BOARD BLOCK

REF. NO.	PARTS NO.	DESCRIPTION
11-Q151, 152	ET-666404	TR 2SD571 K, L
11-J151	EJ-710645	PHONE J YKB21-5066

## 12. HI-FI PC BOARD BLOCK

REF. NO.	PARTS NO.	DESCRIPTION
12-IC501, 502	EI-310036	IC TC4066BP
12-IC503	EI-304657	IC TC4011BP
12-Q501 to 503	ET-330464	TR 2SC2603 D, E
12-D501	ED-346615	D ZENER H HZ12 A2

## 13. MUTE PC BOARD BLOCK

REF. NO.	PARTS NO.	DESCRIPTION
13-Q169	ET-307997	TR 2SA1115 D, E
13-D188, 189	ED-604541	D SILICON H 1S2076



**POWER & RF BLOCK**

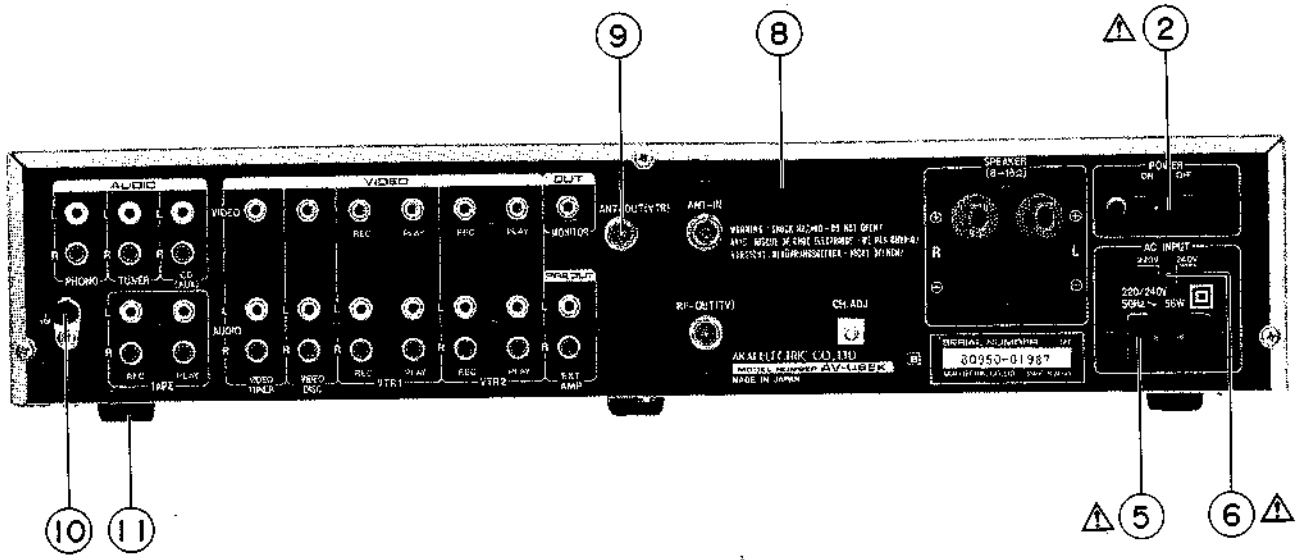
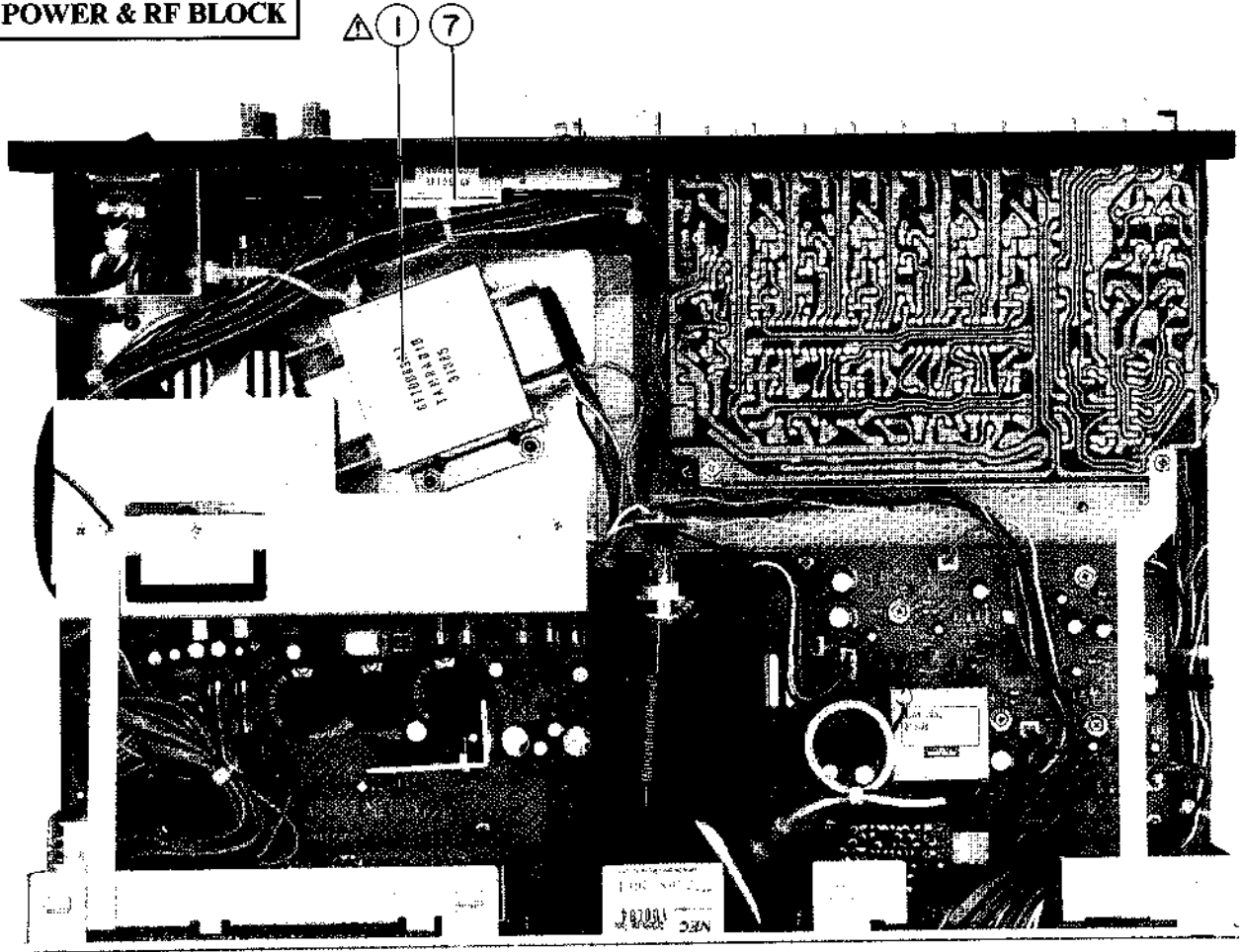

**14. POWER & RF BLOCK**

REF. NO.	PARTS NO.	DESCRIPTION	REF. NO.	PARTS NO.	DESCRIPTION
14-1	BT-710676	△ TRANS POWER AV-U8EO (E), EK, S(T601)	14-7	BV-345125	RF MODULATOR MIW3-253
14-2	ES-710677	△ SW SEESAW SDEISE(SW601)	14-8	BD-710860	PANEL REAR AV-U8EK
14-3	EC-330307	△ CMMY V ECQUF 472M	14-9	EJ-712022	CONNECTOR A YKV11-0096
14-5	EJ-301513	△ SOCKET INLET S-16453 E 2P	14-10	EJ-329610	TERMINAL W/SCREW UB-0067 L
14-6	ES-337898	△ SW SLIDE 00120163	14-11	SA-332850	ROUND FOOT
		01-2(SW602)			1P

**ASSEMBLY BLOCK**

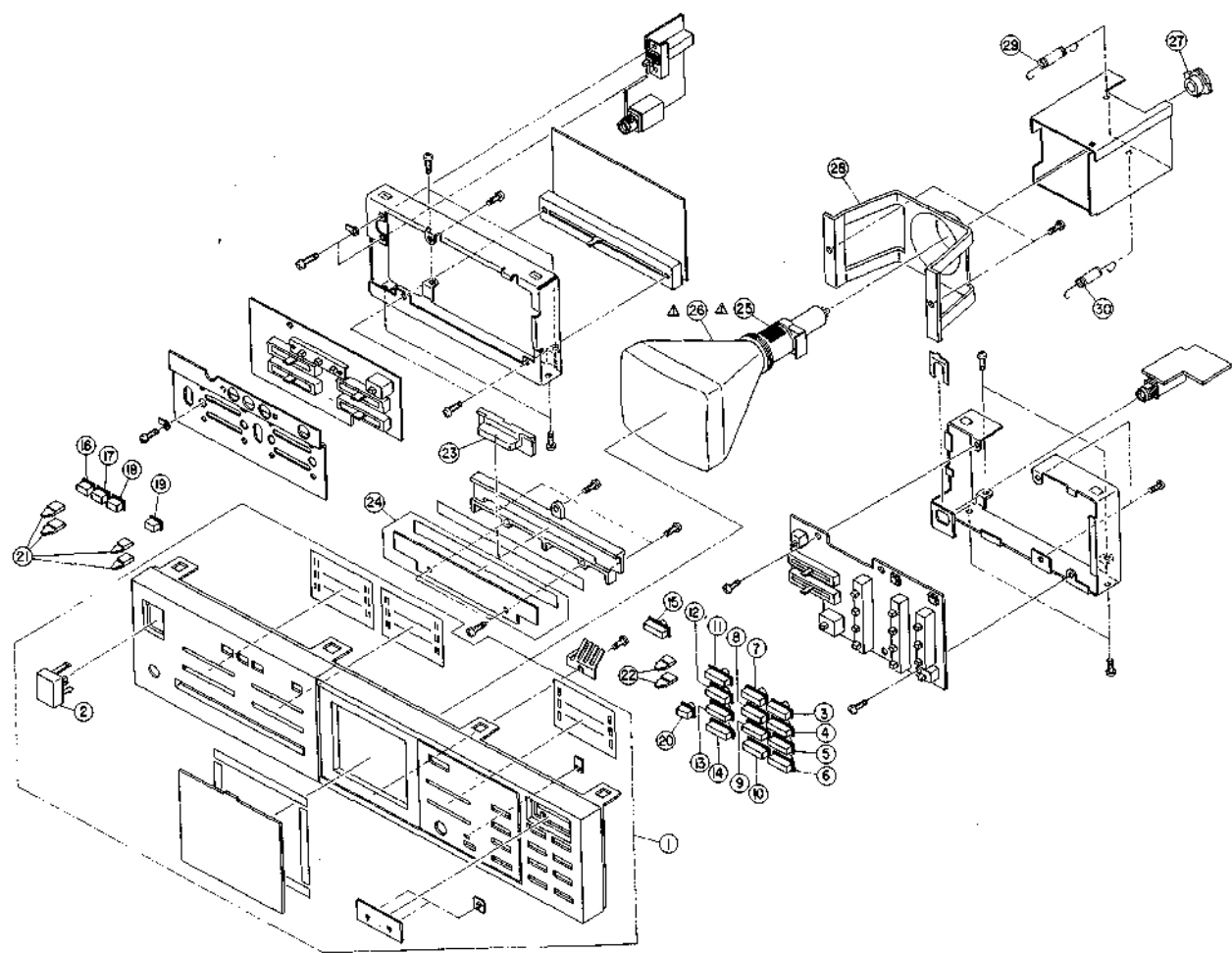

**15. ASSEMBLY BLOCK**

REF. NO.	PARTS NO.	DESCRIPTION
15-1	BD-713649	PANEL FRONT BLK AV-U8EK-B
15-2	SK-713685	KNOB FUNCTION-B
15-3	SK-713650	KNOB A PHONO-B
15-4	SK-713651	KNOB A TUNER-B
15-5	SK-713652	KNOB A CD-B
15-6	SK-713653	KNOB A TAPE-B
15-7	SK-713655	KNOB A TUNER 1-B
15-8	SK-713656	KNOB A V. DISC-B
15-9	SK-713657	KNOB A VTR 1-B
15-10	SK-713658	KNOB A VTR 2-B
15-11	SK-713659	KNOB A TUNER 1-B
15-12	SK-713660	KNOB A V. DISC-B
15-13	SK-713661	KNOB A VTR 1-2-B
15-14	SK-713662	KNOB A VTR 2-1-B
15-15	SK-713663	KNOB A MONITOR-B
15-16	SK-713664	KNOB B L(CH-1)-B

REF. NO.	PARTS NO.	DESCRIPTION
15-17	SK-713683	KNOB B ST-B
15-18	SK-713669	KNOB B R(CH-2)-B
15-19	SK-713670	KNOB B DNR-B
15-20	SK-713671	KNOB B REC SELECTOR
15-21	SK-343009	KNOB OUTPUT
15-22	SK-343009E	KNOB OUTPUT-P2
15-23	SK-713686	KNOB VR-B
15-24	SP-713688	PANEL VR-B
15-25	EO-710666	★ Δ COIL DEF CRT YS-33185(L402)
15-26	EU-710861	Δ CRT 100EB4
15-27	EJ-712019	SOCKET CRT
15-28	MZ-712026	HOLDER CRT
15-29	ZG-712020	SP
15-30	ZG-712021	SP

---

## 16. FINAL ASSEMBLY BLOCK

REF. NO.	PARTS NO.	DESCRIPTION
16-1x	SP-713672	COVER-B UPPER
16-2x	EW-322400	△ AC CORD 2 CORES KS-15/ GTBS-2F B
16-3x	AX-350757	CORD RR-AV100 PIN-PIN
16-4x	EW-321758	CORD VY-15 ANTENNA CABLE

# INDEX

## AV-U8EK-B

PARTS NO.	REF. NO.	PARTS NO.	REF. NO.	PARTS NO.	REF. NO.	PARTS NO.	REF. NO.
AX-350757	16-3x	EF-601964	3-F207	ET-307997	2-Q214	SK-713655	15-7
BA-713675	1-2	EF-623125	3-F204	ET-307997	2-Q110	SK-713656	15-8
BA-713679	1-1	EF-623125	3-F203	ET-307997	2-Q162	SK-713657	15-9
BA-713684	1-3	EF-668474	3-F208	ET-307997	2-Q167	SK-713658	15-10
BD-710860	14-8	EF-668474	3-F209	ET-307997	2-Q166	SK-713659	15-11
BD-713649	15-1	EF-690996	3-F205	ET-307997	2-Q165	SK-713660	15-12
BT-710676	14-1	EF-690996	3-F206	ET-307997	2-Q164	SK-713661	15-13
BV-345125	14-7	EI-304657	4-IC104	ET-307997	2-Q221	SK-713662	15-14
EC-200947	6-C431	EI-304657	12-IC503	ET-307997	2-Q224	SK-713663	15-15
EC-318377	6-C419	EI-310036	12-IC501	ET-307997	2-Q222	SK-713664	15-16
EC-330307	14-3	EI-310036	12-IC502	ET-307997	13-Q169	SK-713669	15-18
EC-337962	3-C269	EI-332259	2-IC302	ET-308141	4-Q101	SK-713670	15-19
EC-337962	3-C270	EI-332259	4-IC102	ET-308141	4-Q103	SK-713671	15-20
EC-343382	3-C273	EI-332259	4-IC103	ET-308141	4-Q104	SK-713683	15-17
EC-712037	6-C425	EI-332259	4-IC101	ET-308141	4-Q102	SK-713685	15-2
EC-712039	6-C427	EI-337842	3-IC212	ET-330464	2-Q323	SK-713686	15-23
EC-713681	6-C426	EI-338406	7-IC201	ET-330464	2-Q307	SP-713672	16-1x
ED-306724	6-D404	EI-338500	3-IC211	ET-330464	2-Q308	SP-713688	15-24
ED-319463	3-D204	EI-348785	2-IC301	ET-330464	2-Q304	ZG-712020	15-29
ED-322238	3-D206	EI-348785	8-IC202	ET-330464	2-Q322	ZG-712021	15-30
ED-346542	3-D210	EI-710668	6-IC401	ET-330464	2-Q302		
ED-346542	3-D209	EJ-301513	14-5	ET-330464	2-Q303		
ED-346615	12-D501	EJ-329610	14-10	ET-330464	2-Q301		
ED-347767	2-D310	EJ-710645	10-J291	ET-330464	2-Q305		
ED-347767	2-D309	EJ-710645	11-J151	ET-330464	2-Q317		
ED-347768	2-D307	EJ-710660	9-J296	ET-330464	2-Q306		
ED-347768	2-D305	EJ-712019	15-27	ET-330464	2-Q216		
ED-347768	2-D304	EJ-712022	14-9	ET-330464	2-Q215		
ED-347768	2-D301	EJ-712030	2-J3A	ET-330464	2-Q108		
ED-347768	2-D302	EJ-712031	2-J3B	ET-330464	2-Q106		
ED-347768	2-D306	EJ-712040	4-J1A	ET-330464	4-Q105		
ED-347768	2-D303	EJ-712041	4-J1B	ET-330464	4-Q111		
ED-347768	2-D308	EJ-712042	4-J1C	ET-330464	4-Q109		
ED-604541	3-D203	EJ-713678	2-J3C	ET-330464	4-Q107		
ED-604541	3-D202	EO-200602	6-L404	ET-330464	5-Q168		
ED-604541	6-D405	EO-419624	2-L307	ET-330464	5-Q163		
ED-604541	6-D408	EO-710666	15-25	ET-330464	5-Q161		
ED-604541	6-D407	EO-710865	6-L401	ET-330464	6-Q401		
ED-604541	13-D188	EO-713682	6-T401	ET-330464	6-Q403		
ED-604541	13-D189	EQ-710665	3-RY201	ET-330464	7-Q223		
ED-604541	3-D207	ER-200595	6-R453	ET-330464	8-Q201		
ED-604541	3-D211	ER-200972	2-R326	ET-330464	8-Q202		
ED-604541	3-D201	ER-200972	2-R383	ET-330464	12-Q503		
ED-604541	4-D105	ER-200972	2-R358	ET-330464	12-Q502		
ED-604541	4-D106	ER-200972	2-R325	ET-330464	12-Q501		
ED-604541	4-D101	ER-200972	2-R360	ET-511694	2-Q320		
ED-604541	4-D102	ER-200972	2-R328	ET-511694	2-Q319		
ED-604541	4-D104	ER-200972	2-R327	ET-511694	2-Q324		
ED-604541	4-D103	ER-315972	3-R289	ET-511694	2-Q405		
ED-604541	4-D107	ER-315982	3-R290	ET-633677	3-Q211		
ED-604541	5-D163	ER-328480	3-R288	ET-666404	11-Q152		
ED-604541	5-D164	ER-328520	6-R452	ET-666404	11-Q151		
ED-604541	5-D168	ER-333015	3-R281	ET-704058	6-Q402		
ED-604541	5-D170	ER-333015	3-R280	ET-710667	6-Q404		
ED-604541	5-D171	ER-710862	3-R278	ET-713673	3-Q212		
ED-604541	5-D172	ER-710862	3-R279	ET-713674	3-Q213		
ED-604541	5-D174	ER-712027	3-R269	EU-710861	15-26		
ED-604541	5-D175	ER-712036	6-R454	EV-315541	6-VR402		
ED-604541	5-D176	ES-337898	14-6	EV-315754	6-VR406		
ED-604541	5-D177	ES-710646	5-SW162	EV-316442	2-VR301		
ED-604541	5-D178	ES-710646	5-SW161	EV-316442	6-VR401		
ED-604541	5-D180	ES-710647	5-SW163	EV-319381	6-VR404		
ED-604541	5-D181	ES-710648	5-SW165	EV-710652	5-VR161		
ED-604541	5-D182	ES-710648	5-SW164	EV-710653	5-VR162		
ED-604541	5-D165	ES-710649	5-SW167	EV-710656	8-VR201		
ED-604541	5-D167	ES-710649	5-SW166	EV-710657	8-VR203		
ED-604541	5-D166	ES-710654	8-SW201	EV-710657	8-VR202		
ED-604541	5-D161	ES-710655	8-SW202	EV-710658	8-VR204		
ED-604541	5-D162	ES-710663	10-SW291	EV-710659	7-VR205		
ED-604541	5-D169	ES-710677	14-2	EV-710866	6-VR403		
ED-707056	5-D184	ET-307997	2-Q313	EW-321758	16-4x		
ED-707056	5-D186	ET-307997	2-Q315	EW-322400	16-2x		
ED-707057	5-D185	ET-307997	2-Q311	MZ-712026	15-28		
ED-710669	6-D406	ET-307997	2-Q318	SA-332850	14-11		
ED-710669	6-D402	ET-307997	2-Q312	SK-343009	15-21		
ED-710669	6-D403	ET-307997	2-Q316	SK-343009E	15-22		
ED-710669	6-D401	ET-307997	2-Q309	SK-713650	15-3		
ED-710863	3-D205	ET-307997	2-Q314	SK-713651	15-4		
EF-558990	9-F202	ET-307997	2-Q310	SK-713652	15-5		
EF-558990	9-F201	ET-307997	2-Q321	SK-713653	15-6		

# SCHEMATIC DIAGRAM AND PC BOARDS

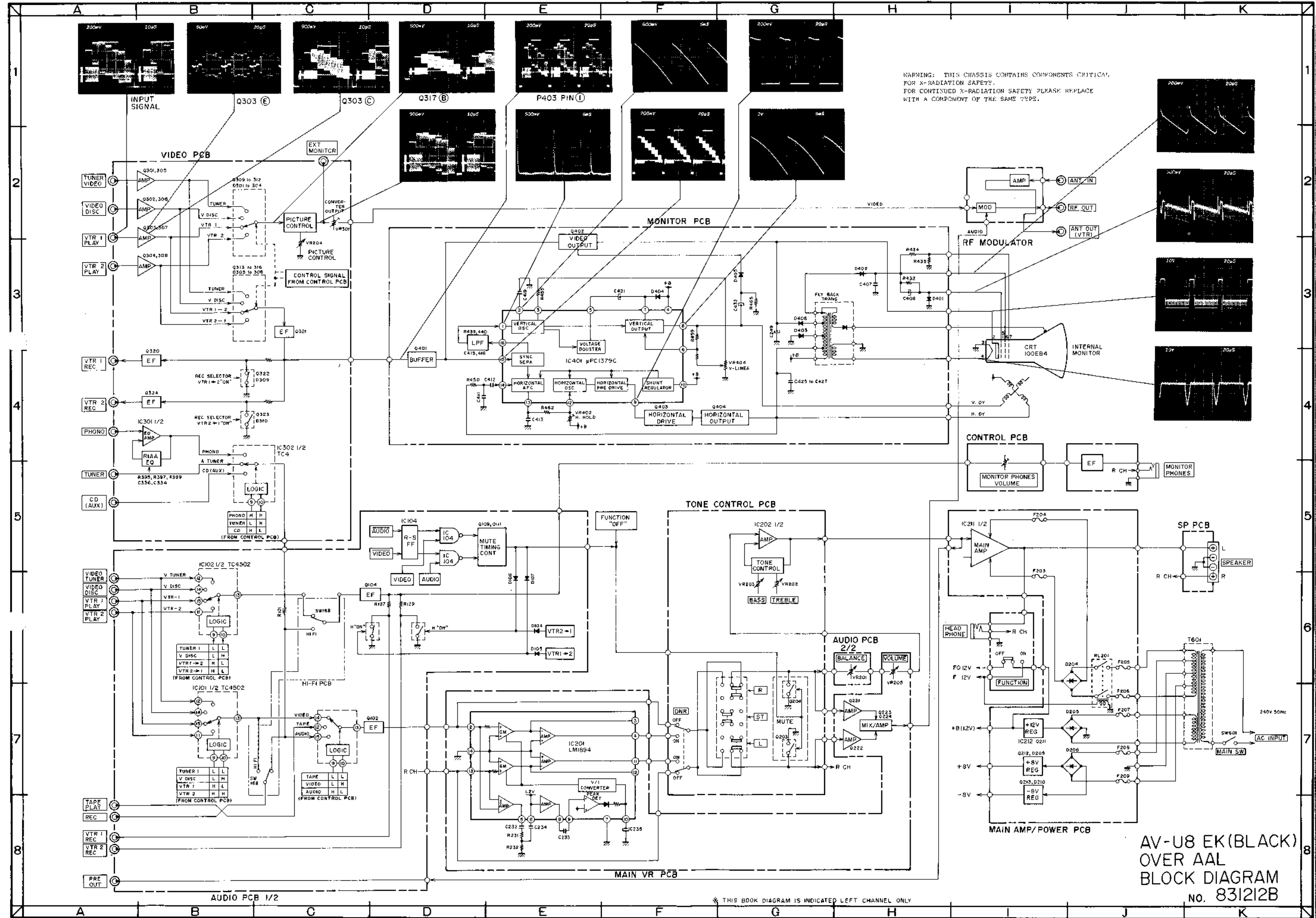

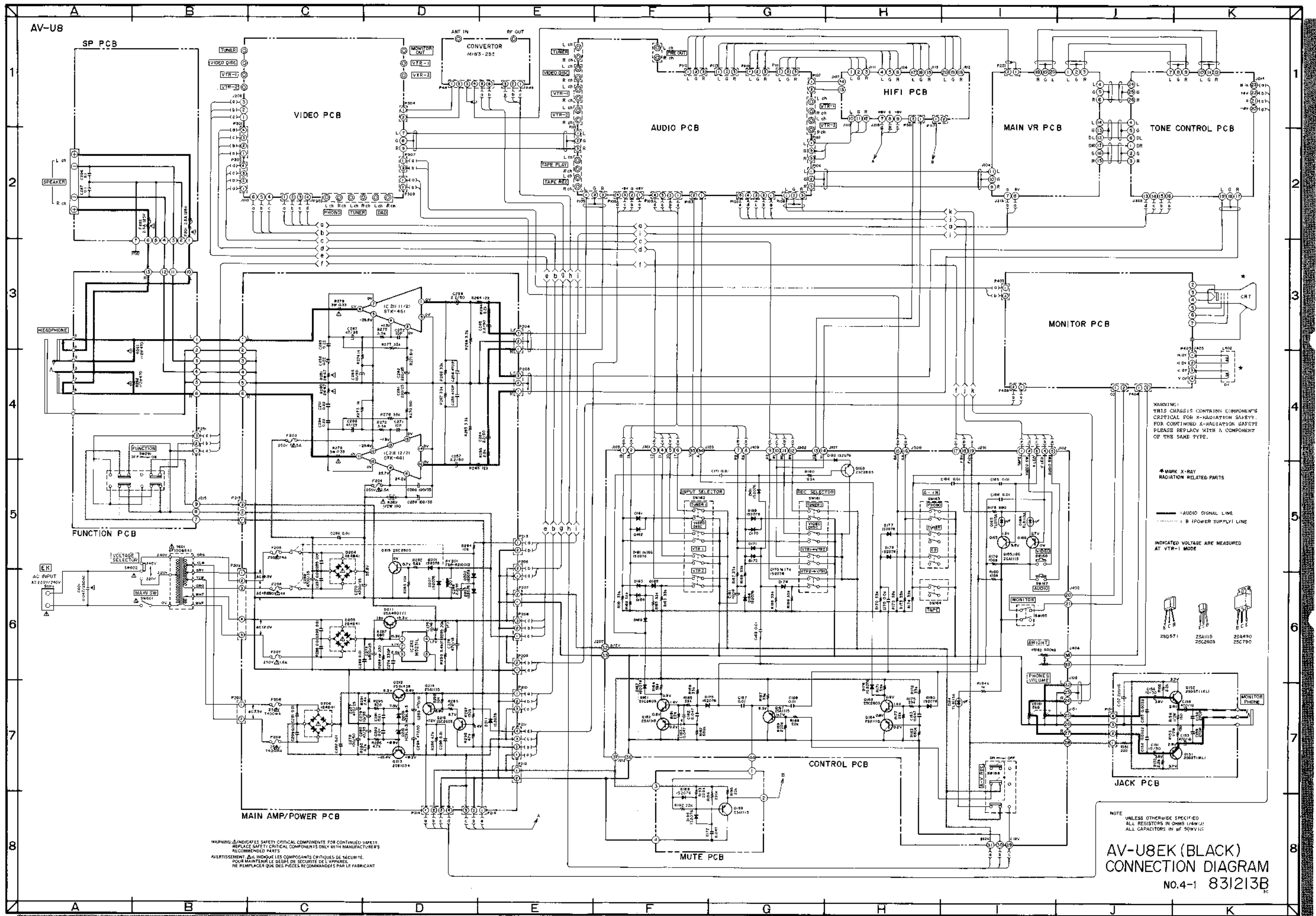

WARNING: INDICATES SAFETY CRITICAL COMPONENTS FOR CONTINUED SAFETY. REPLACE SAFETY CRITICAL COMPONENTS ONLY WITH MANUFACTURER'S RECOMMENDED PARTS.  
AVERTISSEMENT: IL INDIQUE LES COMPOSANTS CRITIQUES DE SÉCURITÉ. POUR MAINTENIR LE DÉGRÉ DE SÉCURITÉ DE L'APPAREIL, NE REMPLACER QUE DES PIÈCES RECOMMANDÉES PAR LE FABRICANT.

NOTE: UNLESS OTHERWISE SPECIFIED ALL RESISTORS IN OHMS 1/4W 5% ALL CAPACITORS IN MF 50V/VOL

AV-U8EK (BLACK) CONNECTION DIAGRAM  
NO.4-1 831213B

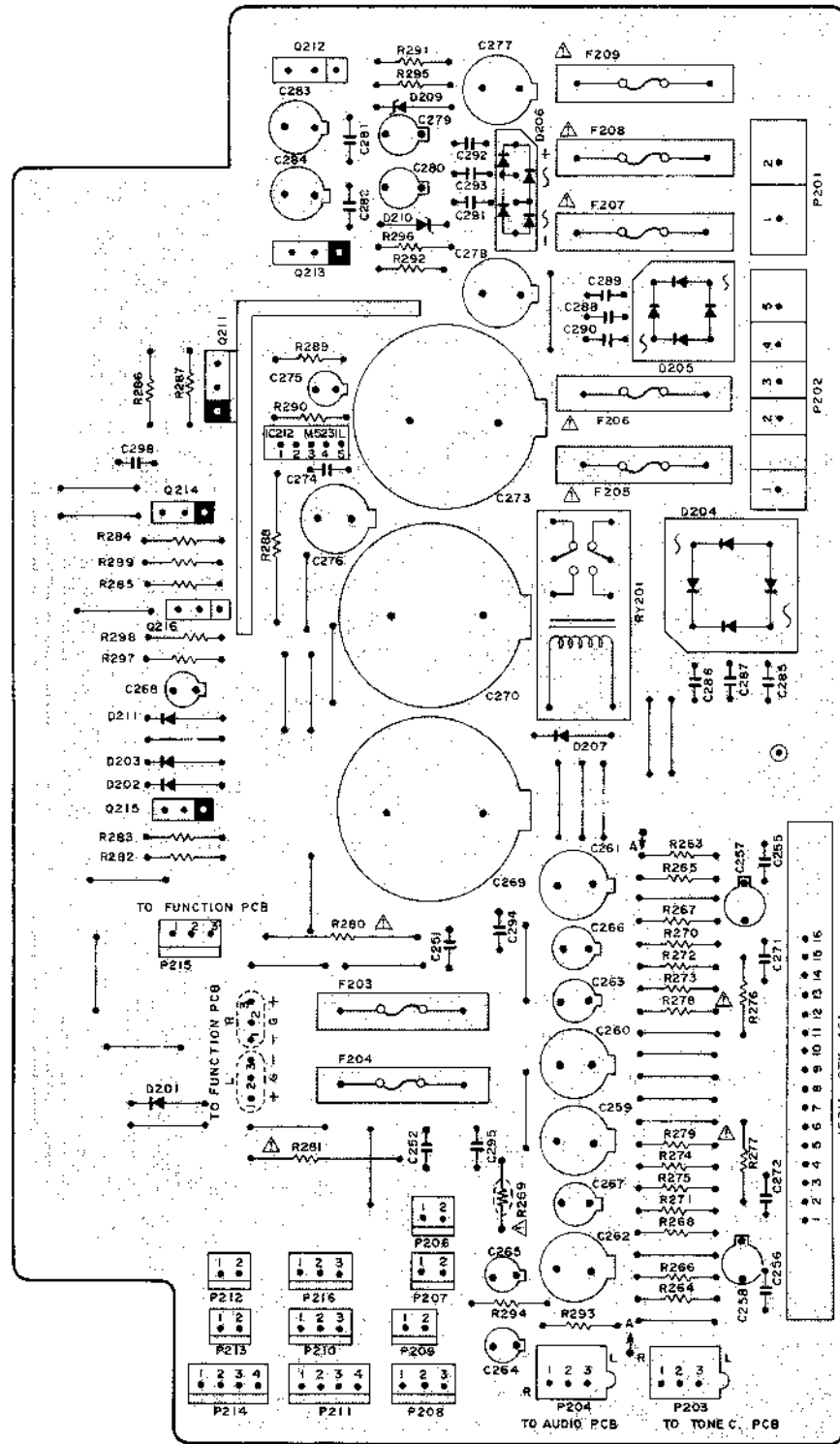

- P206 TO RF MODULATOR
- P207 TO SWITCH
- P209 TO MONITOR PCB
- P208 TO VIDEO PCB
- P210 TO VIDEO PCB
- P211 TO AUDIO PCB
- P212 TO SWITCH
- P213 TO MAIN-VR PCB
- P214 TO TONE C. PCB

- Q211, 213 ----- 2SA490-Y
- Q212 ----- 2SC790-Y
- Q214, 215 ----- 2SA1115 D,E
- Q216 ----- 2SC2603 D,E

WARNING:  $\Delta$  INDICATES SAFETY CRITICAL COMPONENTS FOR CONTINUED SAFETY. REPLACE SAFETY CRITICAL COMPONENTS ONLY WITH MANUFACTURER'S RECOMMENDED PARTS.

AVERTISSEMENT:  $\Delta$  IL INDIQUE LES COMPOSANTS CRITIQUES DE SÉCURITÉ. POUR MAINTENIR LE DEGRÉ DE SÉCURITÉ DE L'APPAREIL, NE REMPLACER QUE DES PIÈCES RECOMMANDÉES PAR LE FABRICANT.

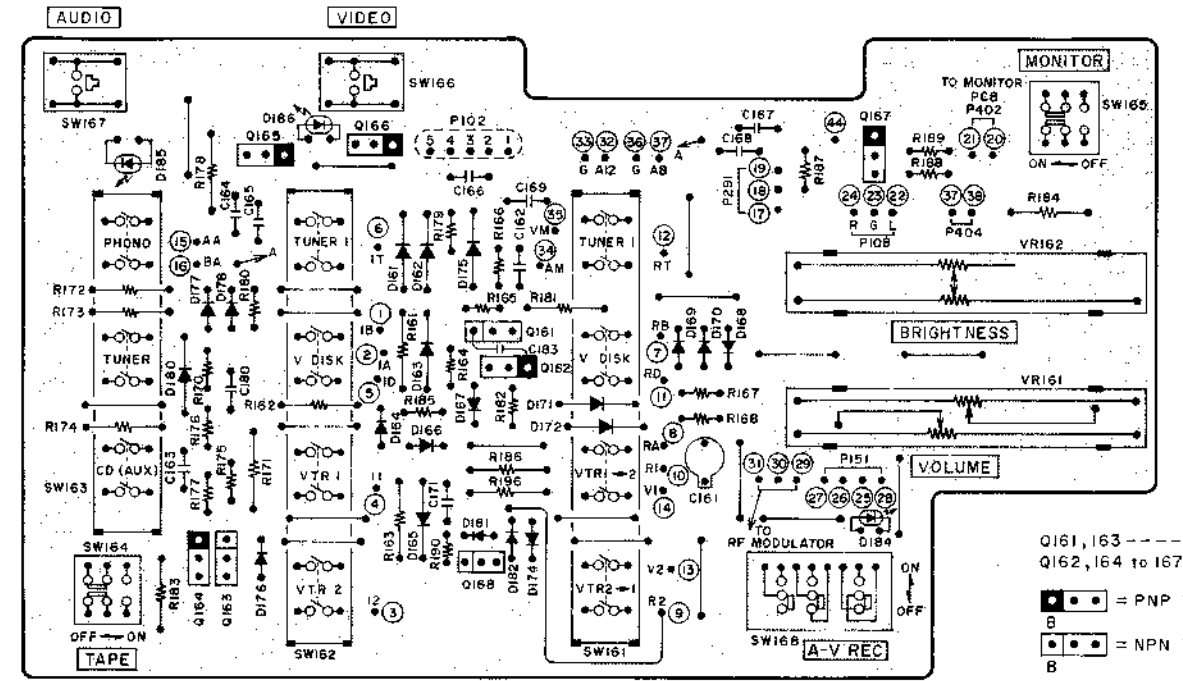
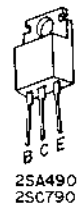

CONTROL PCB

- Q161, 163 ----- 2SC2603 (D,E)
- Q162, 164 to 167 --- 2SA1115 (D,E)
- $\square$  = PNP TRANSISTOR
- $\square$  = NPN TRANSISTOR

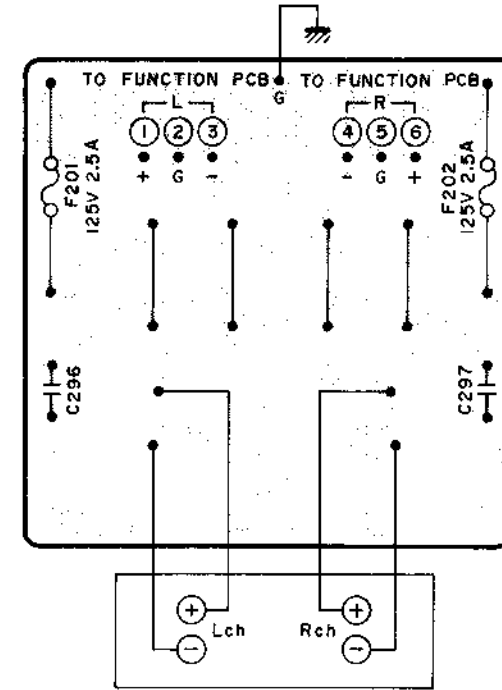

SPEAKER PCB

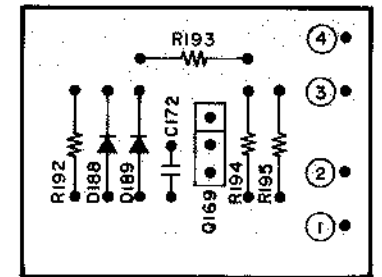

MUTE PCB

- Q169 ----- 2SA1115 (D,E)

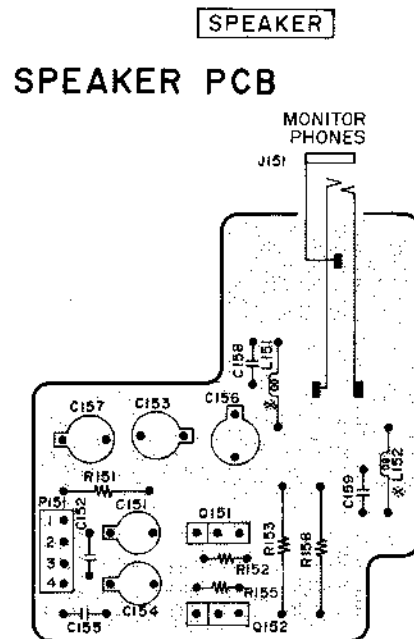

JACK PCB (NEW)

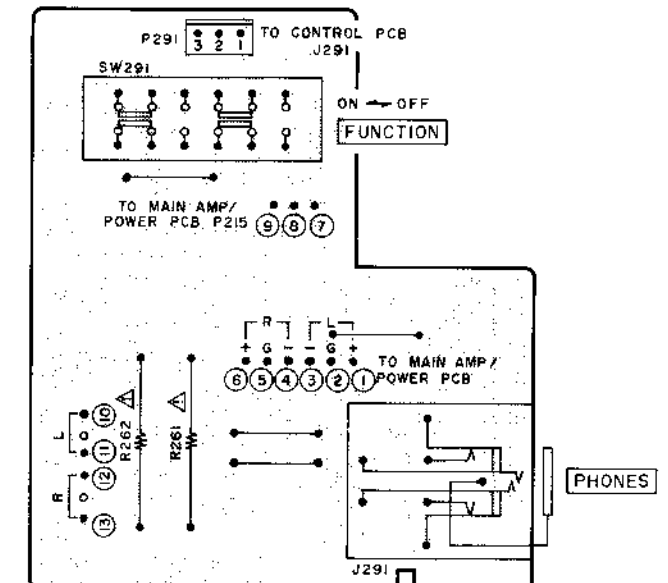

FUNCTION PCB

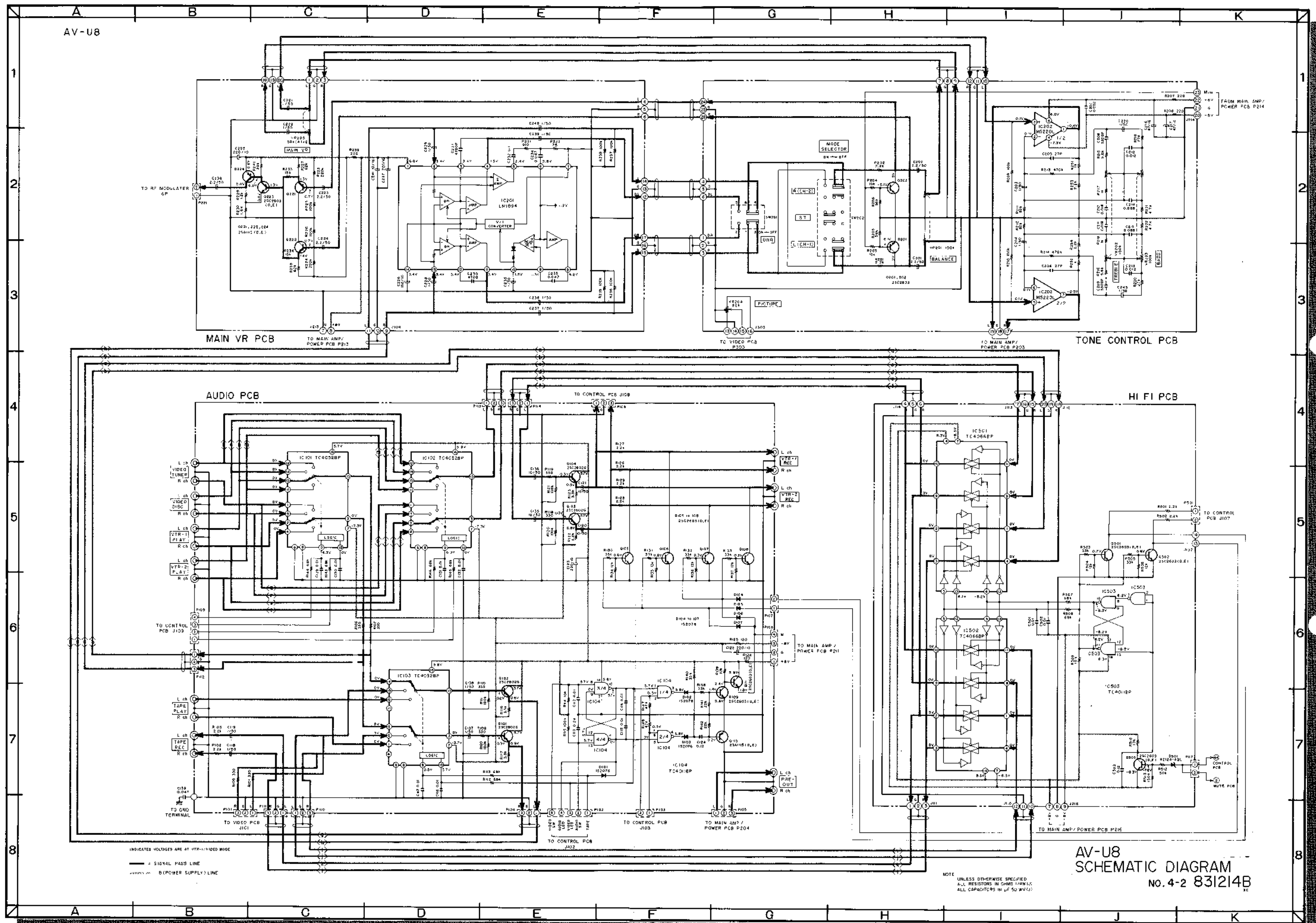





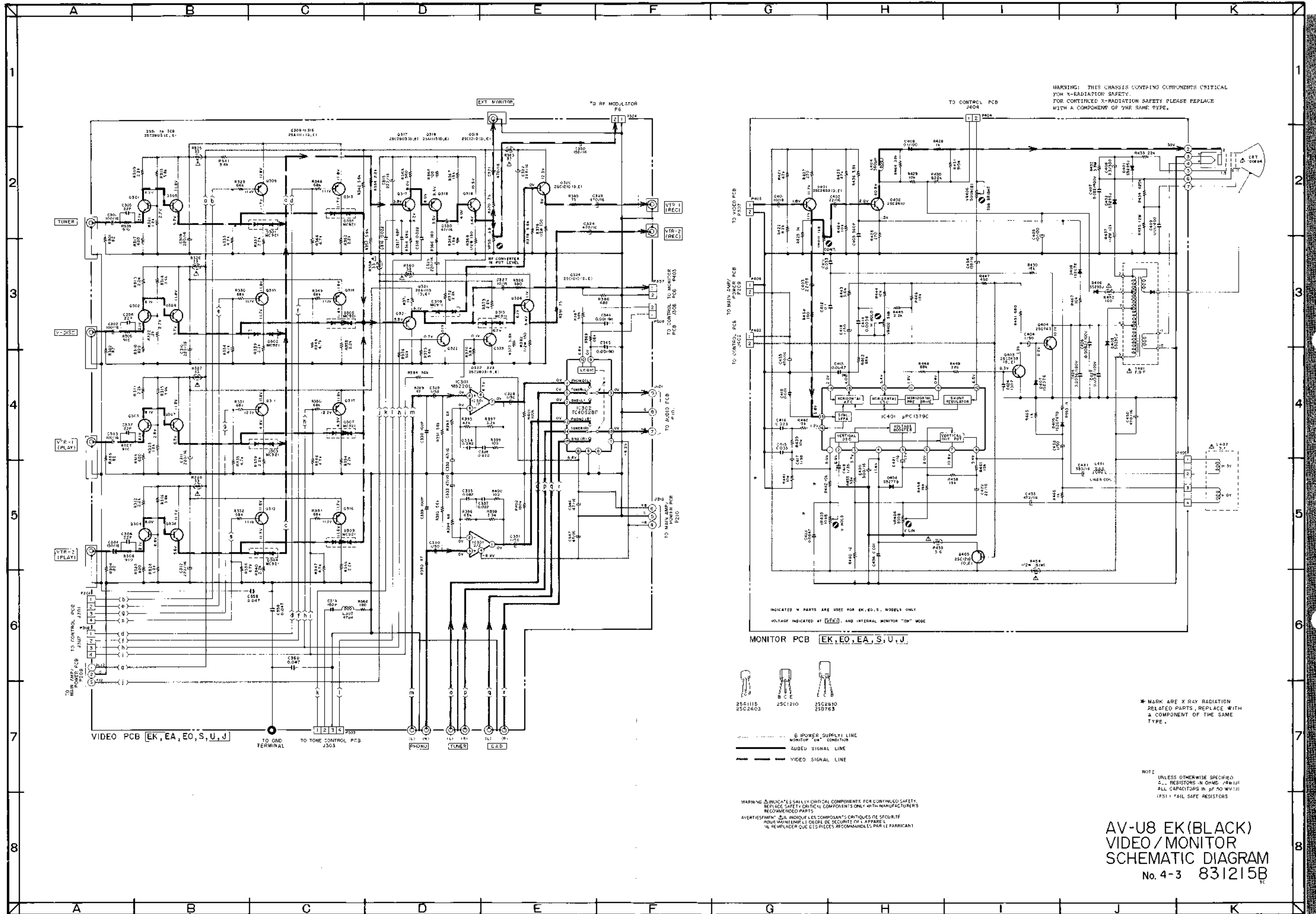

WARNING: THIS CHASSIS CONTAINS COMPONENTS CRITICAL FOR X-RADIATION SAFETY. FOR CONTINUED X-RADIATION SAFETY PLEASE REPLACE WITH A COMPONENT OF THE SAME TYPE.

INDICATED PARTS ARE USED FOR EK, EO, S, U, J MODELS ONLY  
VOLTAGE INDICATED AT "EXT" AND INTERNAL MONITOR "ON" MODE

MONITOR PCB EK, EO, EA, S, U, J

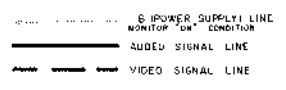
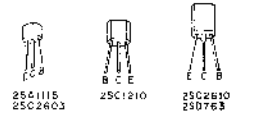

\* MARK ARE X RAY RADIATION RELATED PARTS, REPLACE WITH A COMPONENT OF THE SAME TYPE.

NOTE  
UNLESS OTHERWISE SPECIFIED  
1. RESISTORS IN OHMS /WATT  
ALL CAPACITORS IN μF 50 WV.111  
(F51) TAIL SAFE RESISTORS

WARNING: INDICATES SAFETY CRITICAL COMPONENTS FOR CONTINUED SAFETY. REPLACE SAFETY CRITICAL COMPONENTS ONLY WITH MANUFACTURER'S RECOMMENDED PARTS.  
AVERTISSEMENT: IL INDIQUE LES COMPOSANTS CRITIQUES DE SECURITE. POUR MAINTENIR LE DEGRE DE SECURITE DE L'APPAREIL, IL REPENDRE QUE DES PIECES RECOMMENDEES PAR LE FABRICANT.

AV-U8 EK (BLACK)  
VIDEO/MONITOR  
SCHEMATIC DIAGRAM  
No. 4-3 831215B

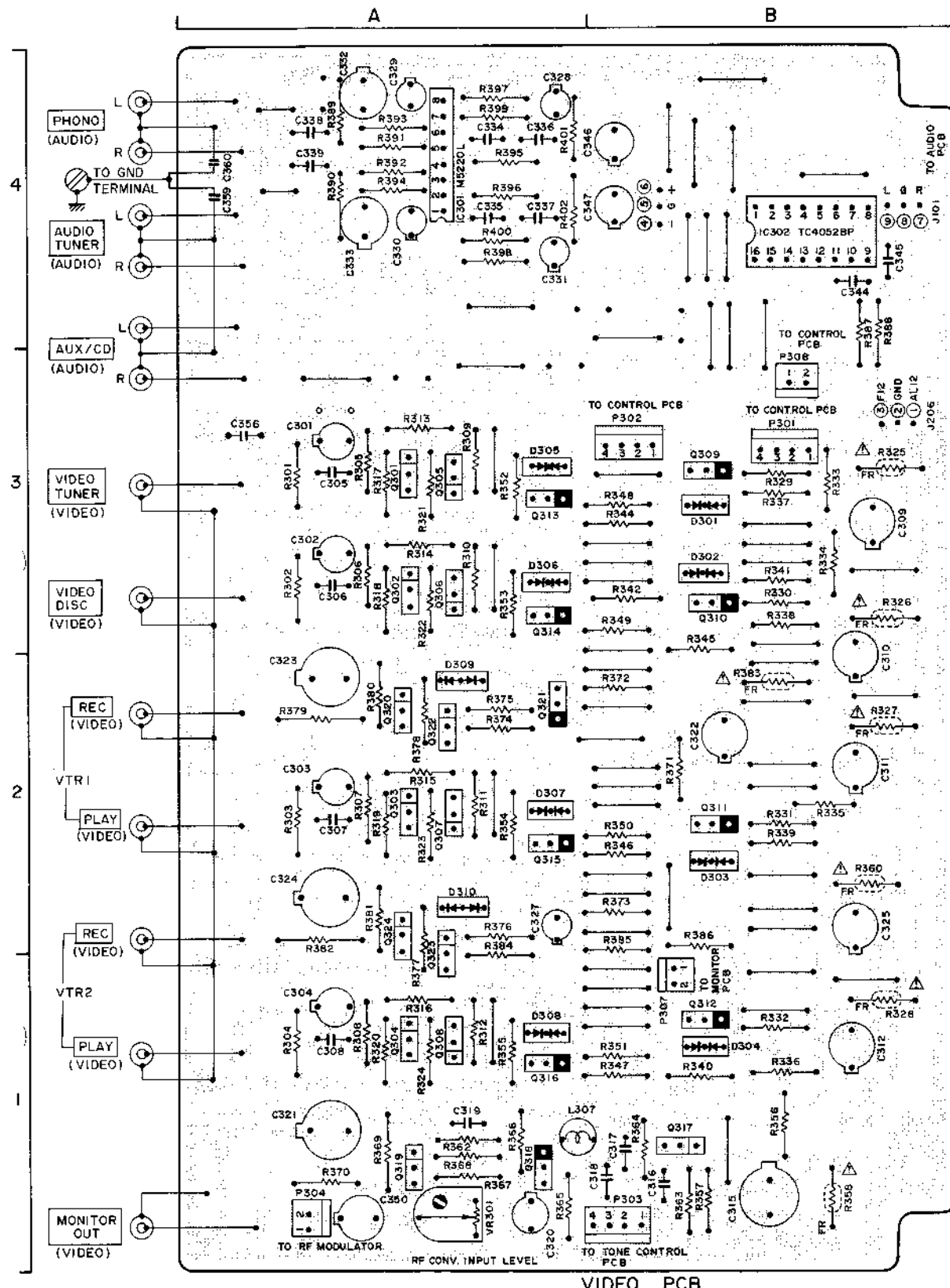

VIDEO PCB

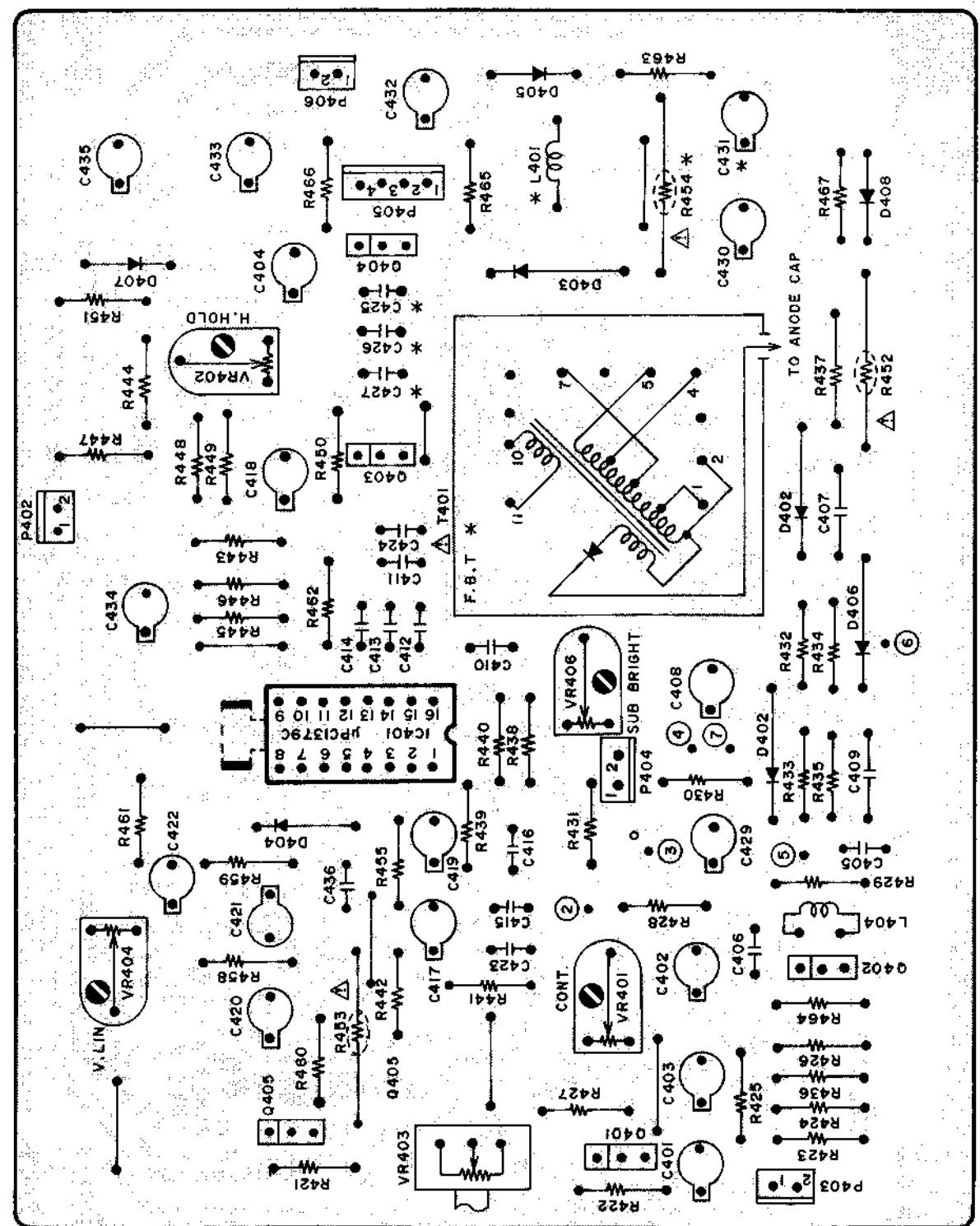

MONITOR PCB

- Location of IC'S
  - IC 301 ---- A4
  - IC 302 ---- B4
- Location of Transistors
  - Q301 ---- A3
  - Q302 ---- A3
  - Q303 ---- A2
  - Q304 ---- A1
  - Q305 ---- A3
  - Q306 ---- A3
  - Q307 ---- A2
  - Q308 ---- A1
  - Q309 ---- B3
  - Q310 ---- B3
  - Q311 ---- B2
  - Q312 ---- B1
  - Q313 ---- A3
  - Q314 ---- A3
  - Q315 ---- A2
  - Q316 ---- A1
  - Q317 ---- B1
  - Q318 ---- A1
  - Q319 ---- A1
  - Q320 ---- A2
  - Q321 ---- A2
  - Q322 ---- A2
  - Q324 ---- A2
  - Q301 to 308, 317, 322, 323 ---- 2SC2603 (D,E)
  - Q309 to 316, 318, 321 ---- 2SA1115 (D,E)
  - Q319, 320, 324 ---- 2SC1210 (D,E)
- Location of Connectors
  - P301 ---- B3
  - P302 ---- B3
  - P303 ---- B1
  - P304 ---- A1
- Transistors
  - = NPN TRANSISTOR
  - = PNP TRANSISTOR

WARNING: ⚠ INDICATES SAFETY CRITICAL COMPONENTS FOR CONTINUED SAFETY. REPLACE SAFETY CRITICAL COMPONENTS ONLY WITH MANUFACTURER'S RECOMMENDED PARTS.

AVERTISSEMENT: ⚠ IL INDIQUE LES COMPOSANTS CRITIQUES DE SÉCURITÉ. POUR MAINTENIR LE DEGRÉ DE SÉCURITÉ DE L'APPAREIL, NE REMPLACER QUE DES PIÈCES RECOMMANDÉES PAR LE FABRICANT.

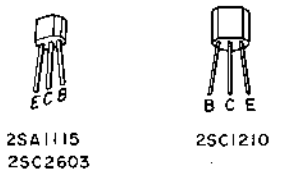

\* MARK IS X-RAY RADIATION RELATED PARTS REPLACE WITH A COMPONENT OF THE SAME TYPE

WARNING: ⚠ INDICATES SAFETY CRITICAL COMPONENTS FOR CONTINUED SAFETY, REPLACE SAFETY CRITICAL COMPONENTS ONLY WITH MANUFACTURER'S RECOMMENDED PARTS

AVERTISSEMENT: ⚠ IL INDIQUE LES COMPOSANTS CRITIQUES DE SÉCURITÉ. POUR MAINTENIR LE DEGRÉ DE SÉCURITÉ DE L'APPAREIL, NE REMPLACER QUE DES PIÈCES RECOMMANDÉES PAR LE FABRICANT

- Q401, 403 ---- 2SC2603 (D,E)
- Q402 ---- 2SC2610
- Q404 ---- 2SD763
- Q405 ---- 2SC1210
- = NPN TRANSISTOR



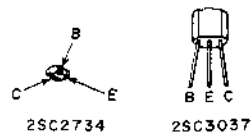
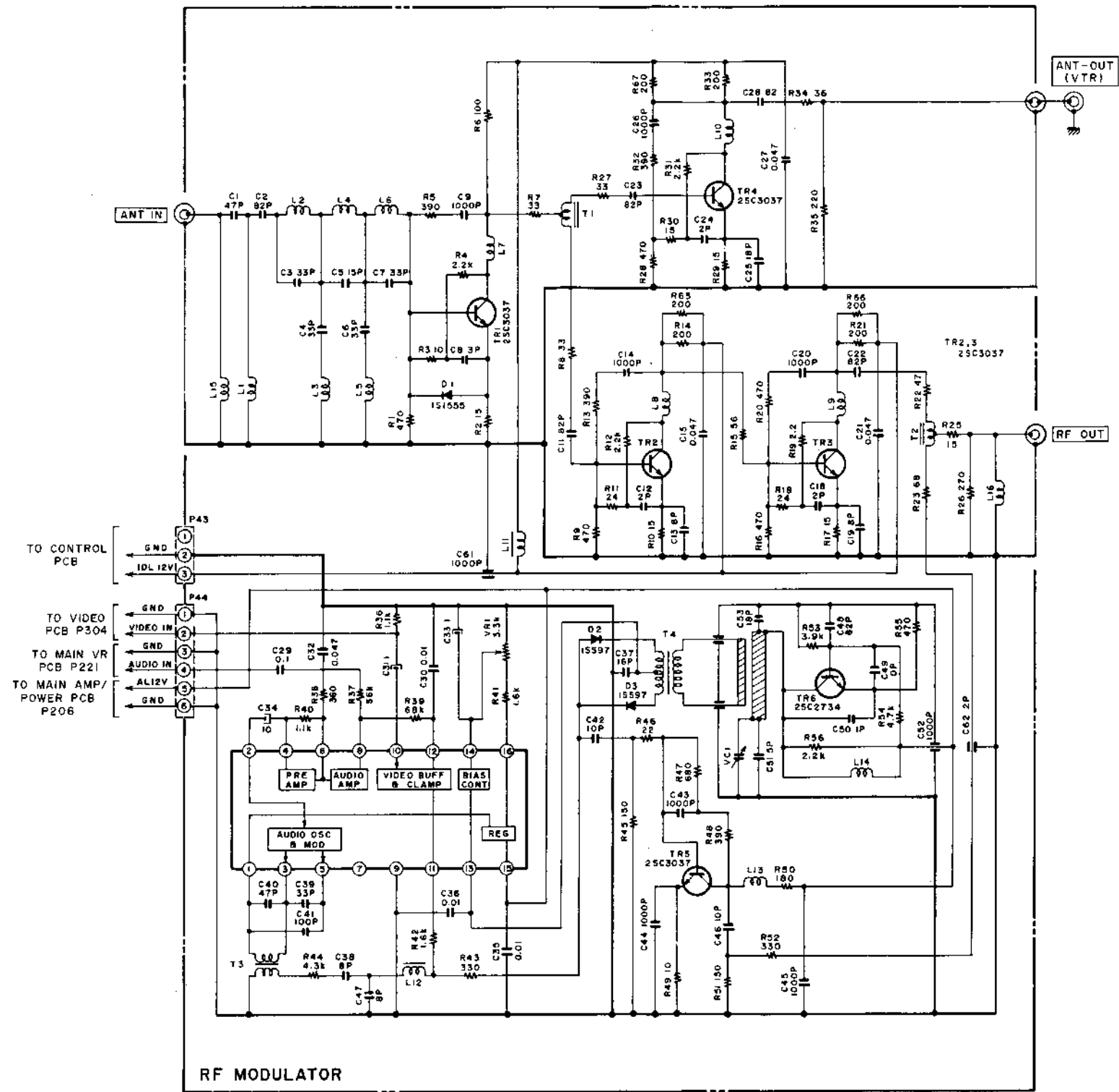

AV-U8EK (BLACK)  
 RF MODULATOR  
 SCHEMATIC DIAGRAM  
 NO. 4-4 831216B

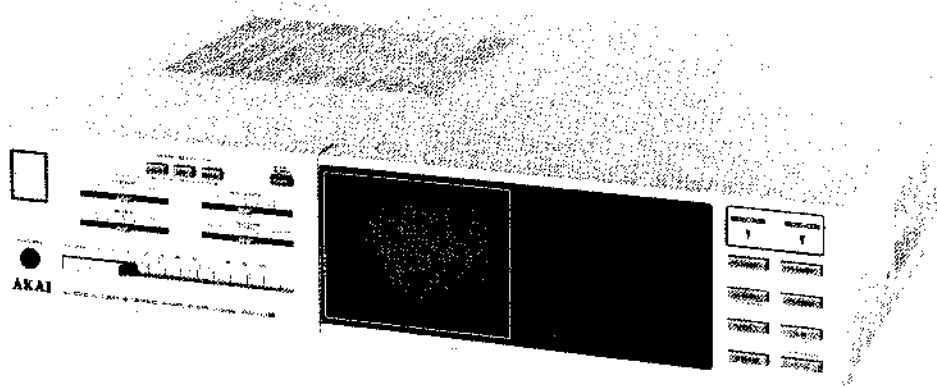

## AUDIO-VIDEO STEREO AMPLIFIER

# MODEL AV-U8

SECTION 1	SERVICE MANUAL.....	3
SECTION 2	PARTS LIST.....	31
SECTION 3	SCHEMATIC DIAGRAM.....	45

# SAFETY INSTRUCTIONS

## SAFETY CHECK AFTER SERVICING

Confirm the specified insulation resistance between power cord plug prongs and externally exposed parts of the set is greater than 10 Mohms, but for equipment with external antenna terminals (tuner, receiver, etc.) and is intended for  $\square$  or  $\square$ , specified insulation resistance should be more than 2.2 Mohms (ground terminals, microphone jacks, headphone jacks, line-in out jacks etc.).

## PRECAUTIONS DURING SERVICING

1. Parts identified by the  $\Delta$  symbol parts are critical for safety.  
Replace only with parts number specified.
2. In addition to safety, other parts and assemblies are specified for conformance with such regulations as those applying to spurious radiation. These must also be replaced only with specified replacements.  
Examples: RF converters, tuner units, antenna selector switches, RF cables, noise blocking capacitors, noise blocking filters, etc.
3. Use specified internal wiring. Note especially:
  - 1) Wires covered with PVC tubing
  - 2) Double insulated wires
  - 3) High voltage leads
4. Use specified insulating materials for hazardous live parts. Note especially:
  - 1) Insulation Tape
  - 2) PVC tubing
  - 3) Spacers (Insulating Barriers)
  - 4) Insulation sheets for transistors
  - 5) Plastic screws for fixing microswitch (especially in turntable)
5. When replacing AC primary side components (transformers, power cords, noise blocking capacitors, etc.), wrap ends of wires securely about the terminals before soldering.

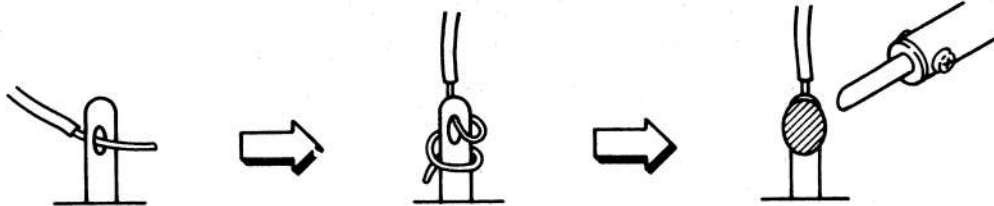

6. Observe that wires do not contact heat producing parts (heatsinks, oxide metal film resistors, fusible resistors, etc.).
7. Check that replaced wires do not contact sharp edged or pointed parts.
8. Also check areas surrounding repaired locations.
9. Use care that foreign objects (screws, solder droplets, etc.) do not remain inside the set.

## X-RADIATION PRECAUTION

The primary source of X-RADIATION in monitor is the picture tube. The picture tube is specially constructed to limit X-RADIATION emissions. For continued X-RADIATION protection, the replacement tube must be the same type as the original. Excessive high voltage may produce potentially hazardous X-RADIATION.

To avoid such hazards, the high voltage must be maintained within specified limit.

## VOLTAGE CONVERSION

Models for Japan, Canada, USA and Germany are not equipped with this facility.

Each machine is preset at the factory according to its destination.

However, if your machine is incorrectly set, follow the procedure below.

- 1) Confirm that the POWER Switch on the rear panel is set to OFF.
- 2) Confirm that the POWER Cord is disconnected.
- 3) Move the AC INPUT selector with a screwdriver so that the marker is above the voltage for your area.

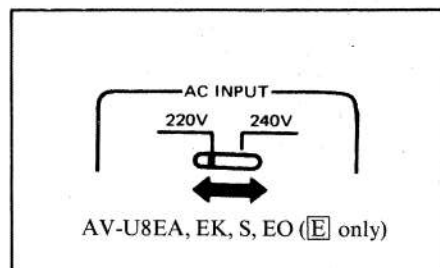

## CYCLE CONVERSION

Cycle conversion is not necessary.

---

SECTION 1

**SERVICE MANUAL**

TABLE OF CONTENTS

I.	SPECIFICATION .....	4
II.	DISMANTLING OF UNIT .....	5
III.	CONTROLS .....	6
IV.	PRINCIPAL PARTS LOCATION.....	7
V.	DESCRIPTION OF THE UNIT .....	8
	1. FEATURES.....	8
	2. SYSTEM EXAMPLES AND MERITS .....	8
	3. THE DIFFERENCE BETWEEN EACH MODEL .....	9
VI.	ADJUSTMENT.....	10
VII.	CLASSIFICATION OF VARIOUS P. C BOARDS .....	12
	1. P. C BOARD TITLES.....	12
	2. COMPOSITION OF VARIOUS P. C BOARDS.....	13

For basic adjustments, measuring methods, and operating principles, refer to  
GENERAL TECHNICAL MANUAL.

# I. SPECIFICATIONS

<b>Audio section</b>	
Rated output power (2-channel driven, 8 ohms) 20 Hz to 20 kHz 1 kHz	20W × 2/0.08% (THD) 22W × 2/0.08% (THD)
Power bandwidth	10 Hz to 30 kHz
Signal to noise ratio PHONO TUNER	80 dB 90 dB
Channel separation (1 kHz)	55 dB
Load impedance Speakers Headphone	8 to 16 ohms 8 to 32 ohms
Input sensitivity/impedance PHONO TUNER (Audio) TAPE PLAY TUNER (Video) V. DISC VTR 1/2	2.5 mV/47 kohms 150 mV/47 kohms 150 mV/47 kohms 150 mV/47 kohms 150 mV/47 kohms 150 mV/47 kohms
Output level/impedance TAPE REC PHONES PRE-OUT	150 mV/less than 2 kohms 0 to 100 mV 1V/less than 1 kohms
PHONO RIAA deviation	20 Hz to 15 kHz ± 1 dB
PHONO maximum input level	70 mV
Tone control BASS TREBLE	± 8 dB (100 Hz) ± 8 dB (10 kHz)
<b>Video section</b>	
Input level/impedance	1 Vp-p/75 ohms
Output level/impedance	1 Vp-p/into 75 ohms
Frequency response	5 Hz to 6 MHz ± 1.5 dB
Crosstalk	Less than - 45 dB/4.43 MHz
Internal TV monitor CRT Horizontal resolution Scanning frequency	4" monochrome More than 250 lines 625 lines/50 Hz or 525 lines/60 Hz switchable except J/U/EA models.
RF output AV-U8J AV-U8EK/EO/S AV-U8U/EA	UHF channels 25 to 37 adjustable, (preset channel 34) UHF channels 30 to 39 adjustable, (preset channel 34) VHF channels 3, 4 switchable, (Preset channel 4)
Power Requirement	100V, 50/60 Hz (JAPAN) 120V, 60 Hz (USA, CANADA) 220V, 50 Hz (EUROPE EXCEPT UK) 240V, 50 Hz (UK and AUSTRALIA) 220/240V, 50 H switchable.
Dimensions	440 (W) × 100 (H) × 330 (D) mm (17.3 × 3.9 × 13.0 inches)
Weight	7.0 kg (15.4 lbs)

\* For improvement purposes, specifications and design are subject to change without notice.



## II. DISMANTLING OF UNIT

In case of trouble, etc. necessitating dismantling, please dismantle in the order shown in the photographs. Reassemble in reverse order.

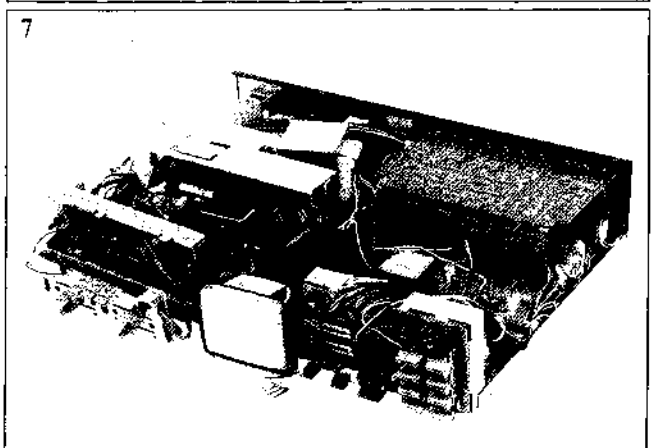
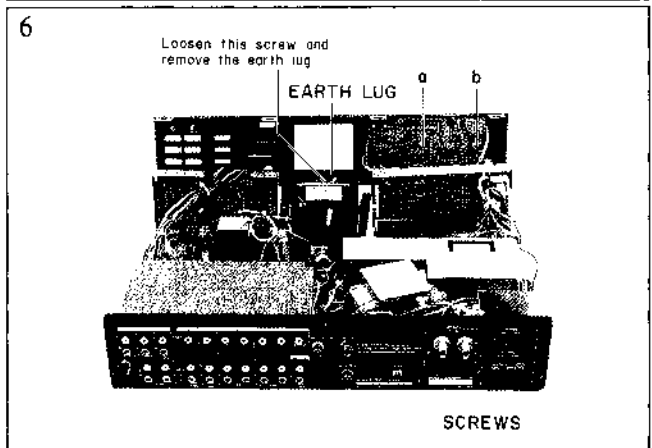
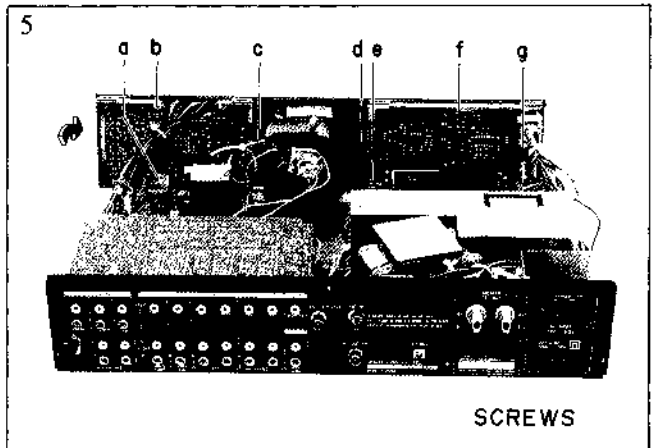
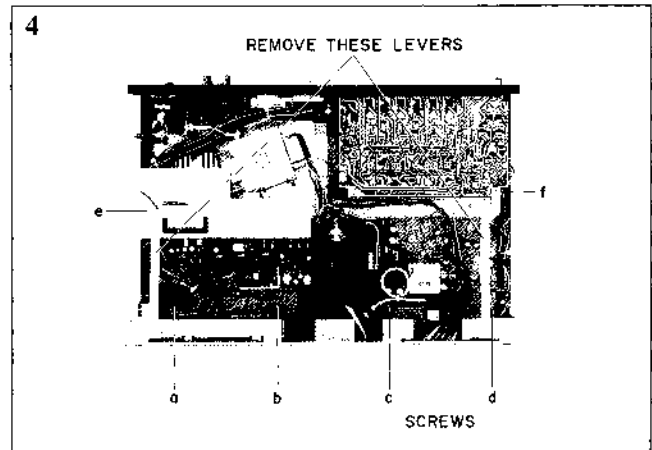
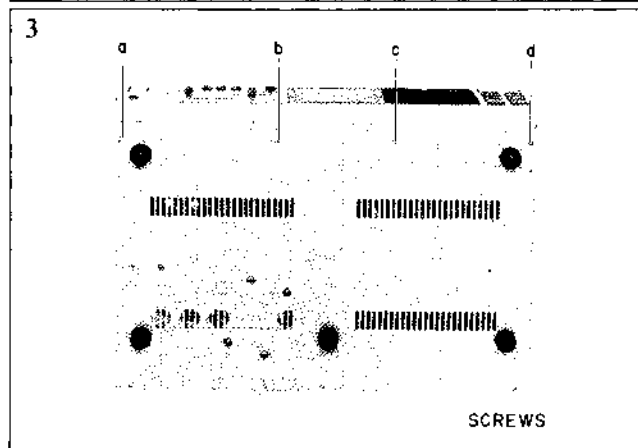
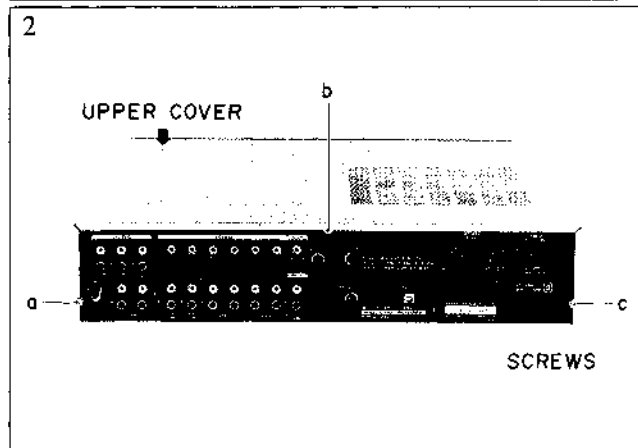
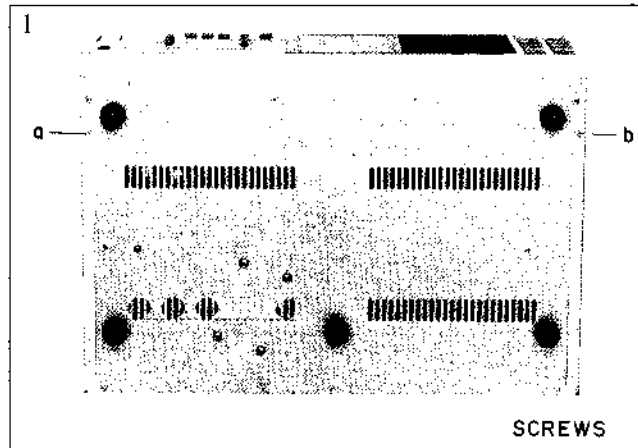

### III. CONTROLS

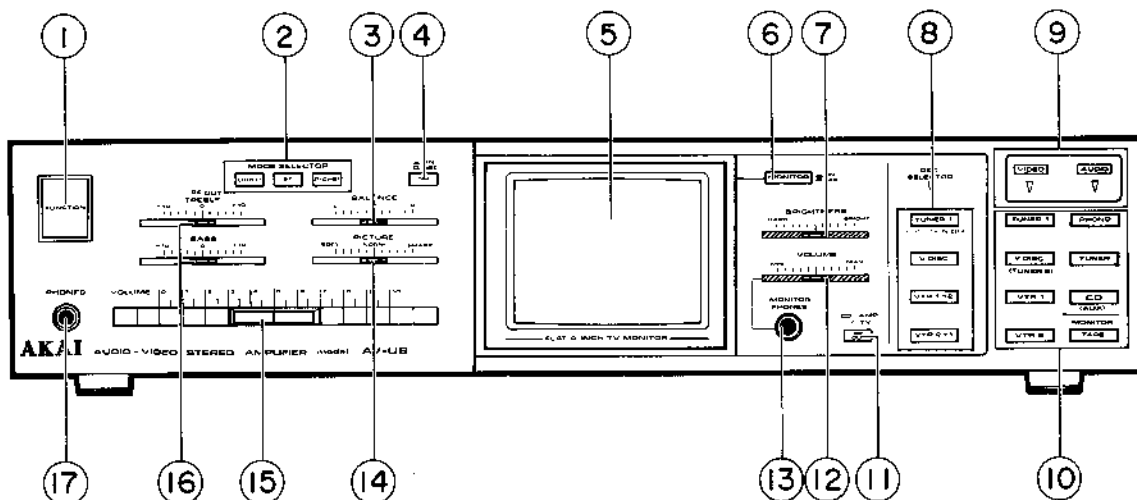

Fig. 3-1. Front View

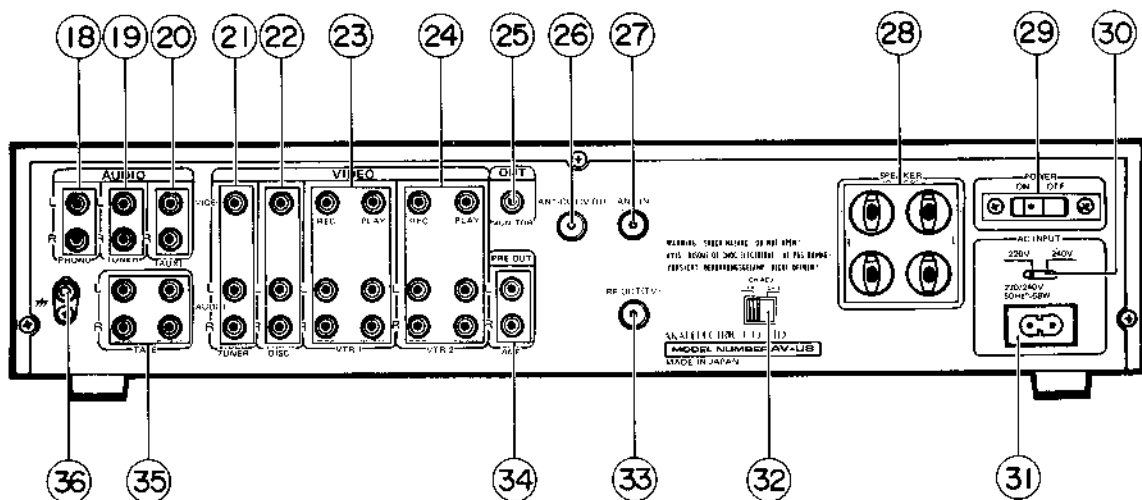

Fig. 3-2. Rear View

- |   |  |
|---|--|
| 1. FUNCTION BUTTON  | 18. AUDIO PHONO INPUT JACKS  |
| 2. MODE SELECTOR SWITCH   | 19. AUDIO TUNER INPUT JACKS  |
| 3. BALANCE CONTROL  | 20. AUDIO CD/AUX INPUT JACKS   |
| 4. DNR (Dynamic Noise Reduction) ON/OFF BUTTON  | 21. VIDEO TUNER INPUT JACKS  |
| 5. MONITOR SCREEN   | 22. VIDEO DISC INPUT JACKS   |
| 6. MONITOR ON/OFF BUTTON  | 23. VTR 1 REC/PLAY JACKS   |
| 7. BRIGHTNESS CONTROL (for built-in monitor)  | 24. VTR 2 REC/PLAY JACKS   |
| 8. REC SELECTOR BUTTONS   | 25. MONITOR OUTPUT JACK  |
| 9. VIDEO/AUDIO SELECTOR BUTTON AND INDICATORS   | 26. ANTENNA (ANT) OUT JACK   |
| 10. INPUT SELECTOR BUTTONS  | 27. ANTENNA (ANT) IN JACK  |
| 11. 50/60 Hz SELECTOR BUTTON (for AV-U8 EK/EO/S models) A/V REC SOURCE SELECT BUTTON (for AV-U8J model) TV/AMP SELECT BUTTON (for AV-U8U/EA models) | 28. SPEAKER OUTPUT TERMINALS   |
| 12. MONITOR PHONES VOLUME CONTROL   | 29. MAIN POWER ON/OFF SWITCH   |
| 13. MONITOR PHONES JACK   | 30. AC INPUT SELECTOR (EK, EA, EO, (E), S models only)   |
| 14. PICTURE CONTROL   | 31. AC INLET (EK, EA, EO, (E), S models only)  |
| 15. VOLUME CONTROL  | 32. RF CONVERTER CHANNEL (CH.) SELECTOR FOR U, EA MODELS & CHANNEL ADJUSTMENT (ADJ.) HOLE FOR EK, EO, S AND J MODELS |
| 16. TONE CONTROL (BASS and TREBLE)  | 33. RF OUT JACK  |
| 17. PHONES JACK   | 34. PRE OUT JACKS (FOR EXTERNAL AMP)   |
|   | 35. AUDIO TAPE REC/PLAY JACKS  |
|   | 36. GROUND TERMINAL  |

# IV. PRINCIPAL PARTS LOCATION

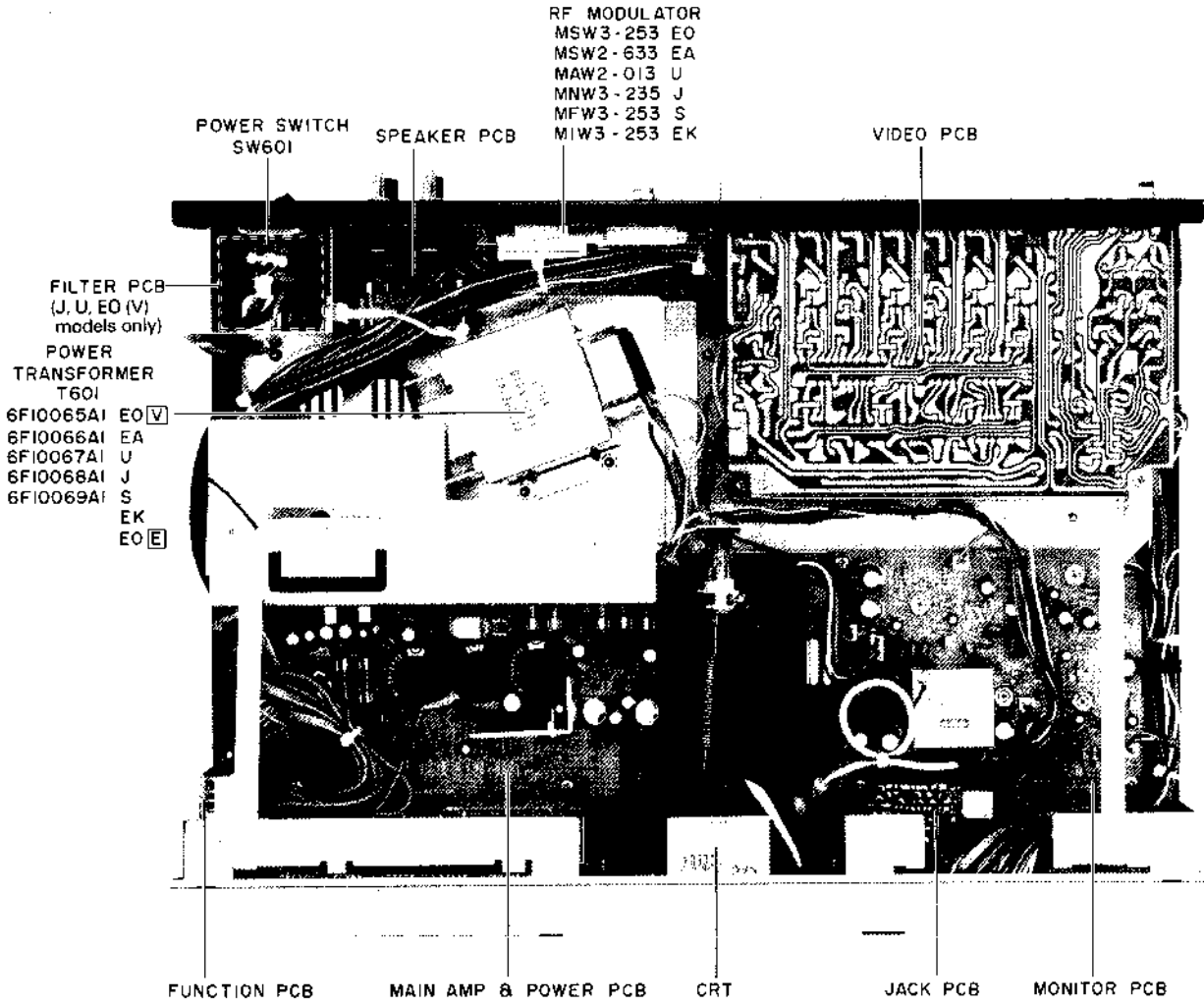

Fig. 4-1

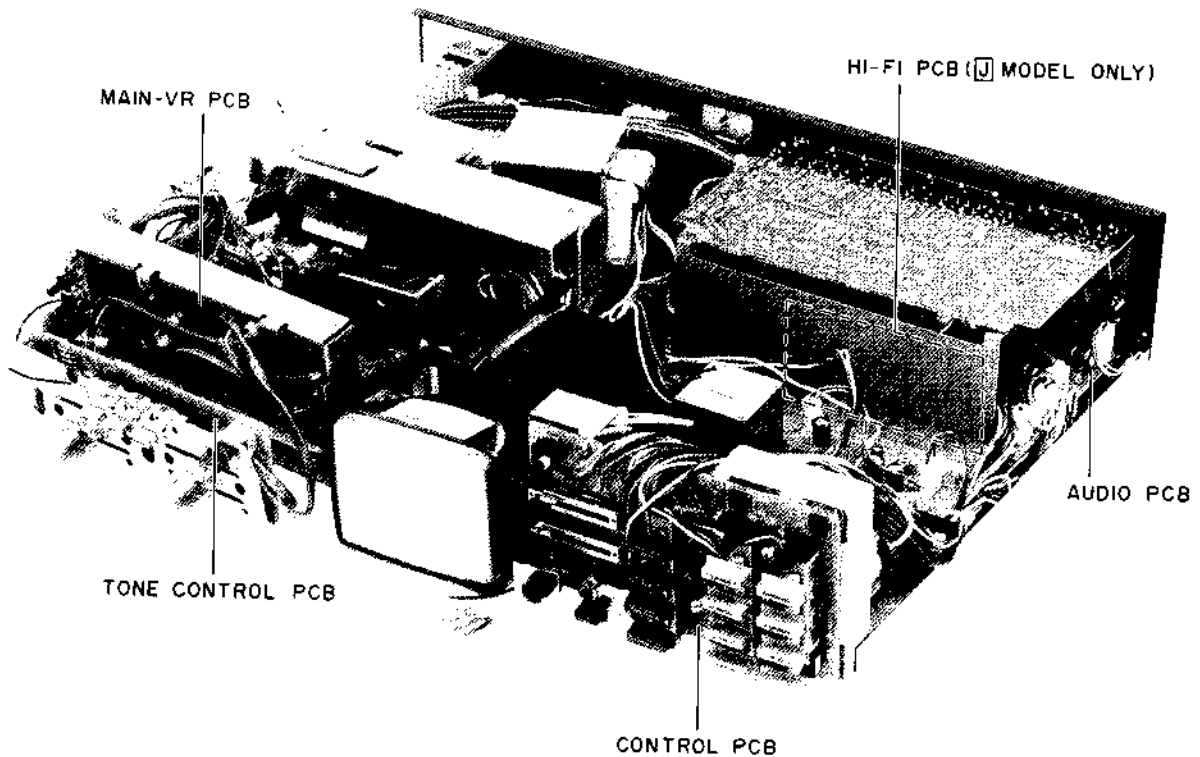

Fig. 4-2

# V. DESCRIPTION OF THE UNIT

## 5-1 FEATURES

1. A full range of input capability, handling up to 4 audio and 4 video components.
2. One-touch selection for combining any video and Hi-Fi audio components.
3. The AV-U8 makes it possible to record and dub between any components while normal TV viewing goes on uninterrupted.
4. The 4 inch monitor and headphone capability, allows you to watch and listen to the program being recorded independently of the main monitor-especially usefull for editing.
5. The DNR (Dynamic Noise Reduction) feature, reduces tape hiss in any source by 10 dB, making high quality sound reproduction simple.
6. The AV-U8's controls, allow you to adjust the monitor picture as you like.
7. Line and RF terminals make it possible to connect TV's that have only antenna inputs, line inputs or both.
8. The built-in signal divider feature allows the signal from your TV antenna to be sent to both the television and video tape recorder.
9. The pre-out terminals allow you to connect high output amplifiers.

## 5-2 SYSTEM EXAMPLES AND MERITS

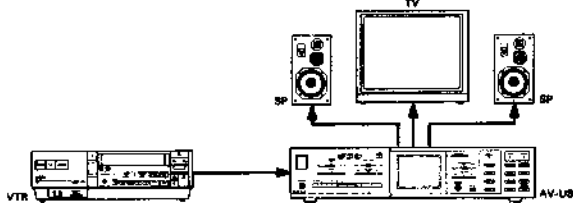
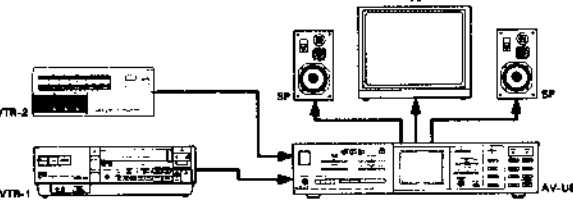
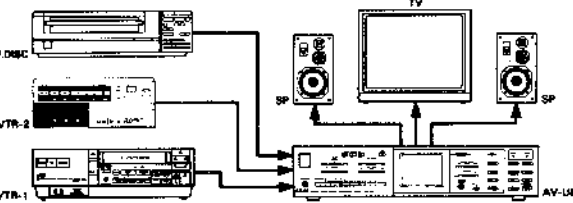
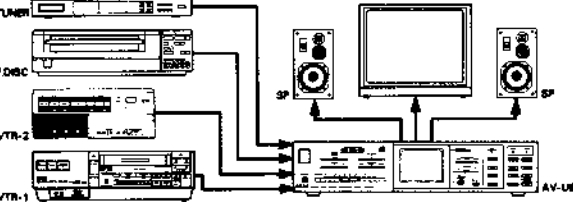
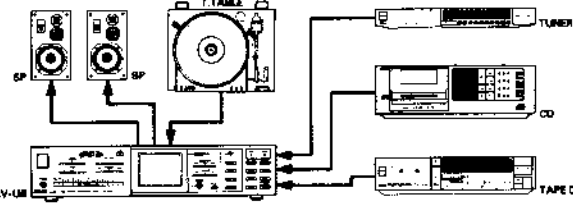
System Examples	Merits
	<ol style="list-style-type: none"> <li>1. Hi-Fi stereo reproduction with video tape recorders.</li> <li>2. IMS operation with the built-in monitor.</li> <li>3. The built-in monitor allows monitoring of the program being received (recorded) by the video tape recorder.</li> <li>4. When the TV set is being used independently, the built-in monitor can be used as a playback monitor for the video tape recorder.</li> </ol>
	<p><b>1 ~ 4 same as above</b></p> <ol style="list-style-type: none"> <li>5. One-touch selection of the video images from two video tape recorders.</li> <li>6. Dubbing of VTR-1 → VTR-2.</li> <li>7. The video frames being dubbed can be monitored with the built-in monitor.</li> </ol>
	<p><b>1 ~ 7 same as above</b></p> <ol style="list-style-type: none"> <li>8. One touch selection of video disk VTR-1 and VTR-2.</li> <li>9. Hi-Fi stereo reproduction of video disk and VTR.</li> <li>10. Simultaneous dubbing from video disk to VTR-1 and VTR-2.</li> </ol>
	<p><b>1 ~ 10 same as above</b></p> <ol style="list-style-type: none"> <li>11. Recording of the TV tuner onto VTR-1 and VTR-2.</li> <li>12. The VS-9 makes multiplex TV broadcasts possible even with mono TV sets.</li> </ol>
	<p><b>13. Even as an ordinary audio amplifier, the AV-U8 possesses all of the basic functions required.</b></p>

### 5-3 THE DIFFERENCE BETWEEN EACH MODEL

MODEL NAME	(SEE NOTE 1) TV/AMP SWITCH	(SEE NOTE 2) A/V REC SOURCE SWITCH	INTERNAL MONITOR 50/60 SWITCH	(SEE NOTE 3) REC SELECTOR AUTO SWITCH
AV-U8EA	○	—	—	○
AV-U8EK	—	—	○	○
AV-U8EO	—	—	○	○
AV-U8S	—	—	○	○
AV-U8U	○	—	—	—
AV-U8J	—	○	—	—

**Note:**

1. TV/Amp SWITCH  
Switching of the signal from ANT IN or Modulator to RF out of VHF RF Modulator.
2. A/V REC SOURCE SWITCH  
Switching of Audio signal only for recording from PHONO, TUNER, or CD (AUX) to VTR1 or VTR2, and from VIDEO TUNER, VIDEO DISC, VTR1 or VTR2 to Tape.
3. Auto REC SELECTOR  
This function is intended to accommodate timer recording with the Auto REC Selector AKAI VTR or equivalent, the REC Selector may have been set with the function "ON" which in the switching the function "OFF" will automatically set the selector at the VIDEO TUNER position and connect the VIDEO TUNER to REC OUT of VTR1, thereby enabling timer recording.

# VI. ADJUSTMENT

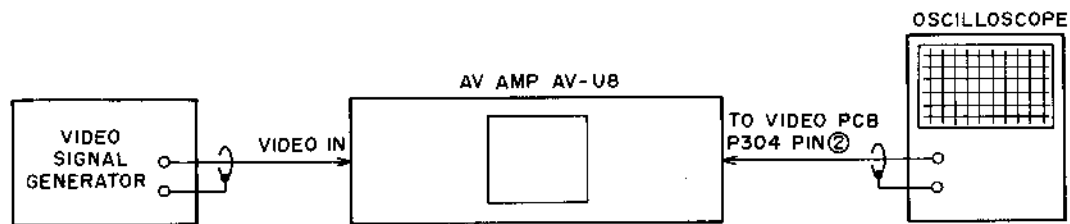
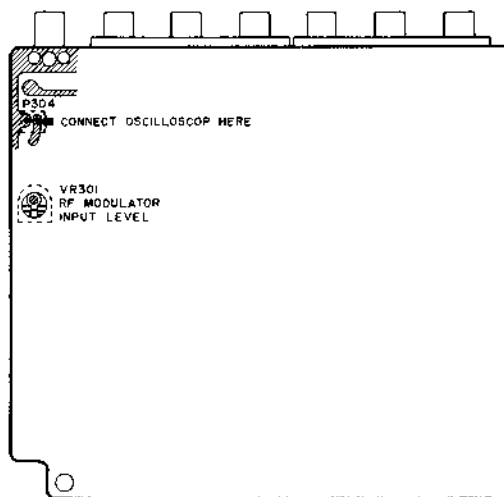
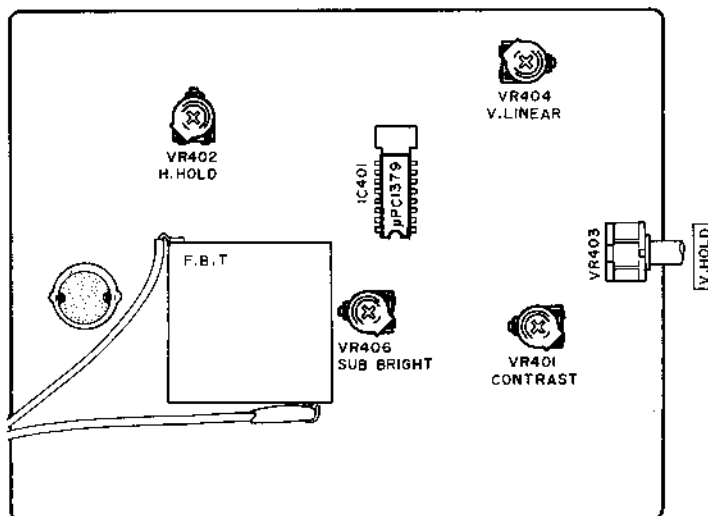

Fig. 6-1



VIDEO PCB (VIEW FROM PATTERN SIDE)

Fig. 6-2 VIDEO P. C BOARD ADJUSTMENT POINT



MONITOR PCB

Fig. 6-3 MONITOR P. C BOARD ADJUSTMENT POINT

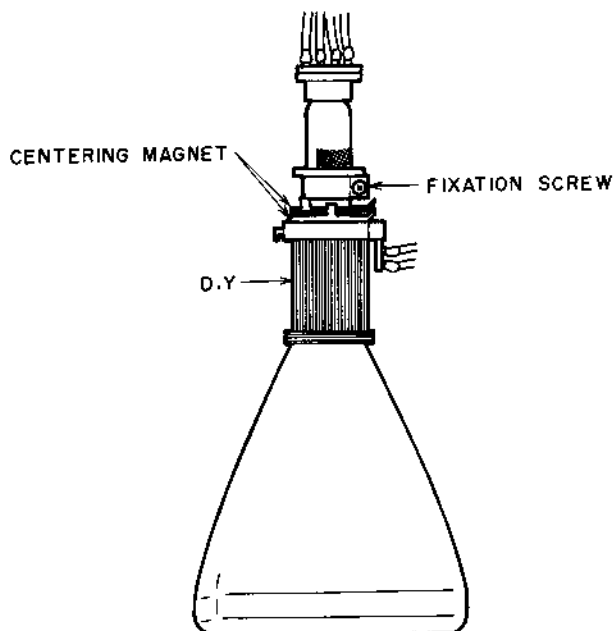

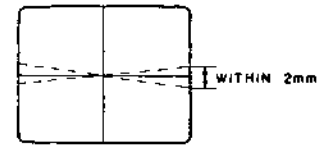

Fig. 6-4

Step	Adjustment Item	Input	Test Point	Adjustment Parts	Result & Remarks
1	RF-Modulator Input Level	Stear Step 1.0Vp-p	P304 (pin 2) (Video PCB)	VR301 (Video PCB)	<ul style="list-style-type: none"> <li>● Set the picture control volume to normal position.</li> <li>● Connect an oscilloscope to P304 pin ② and adjust VR301 so that the video level of RF modulator input is 1.0Vp-p.</li> </ul>
2	H. Hold	Stear Step 1.0Vp-p	Internal Monitor Screen	VR402 (Monitor PCB)	<ul style="list-style-type: none"> <li>● Fix at position at which the picture synchronizes one picture.</li> </ul>
3	Centering and Linealty	Stear Step 1.0Vp-p	Internal Monitor Screen	Centering Magnet VR404 (Monitor PCB)	<ul style="list-style-type: none"> <li>● Adjust centering magnet so that the center of the picture reflected on the monitor screen comes to the center.</li> <li>● At this time, adjust VR404 so that the linealty at upper part, center part and lower part is obtained.</li> </ul>
4	Sub Bright	No Signal Input	Internal Monitor Screen	VR406 (Monitor PCB)	<ul style="list-style-type: none"> <li>● Set the bright volume is three graduations. Adjust VR406 so that the point which the raster is disappeared.</li> </ul>
5	Contrast	Stear Step 1.0Vp-p	Internal Monitor Screen	VR401 (Monitor PCB)	<ul style="list-style-type: none"> <li>● Set the bright volume is maximam.</li> </ul>  <ul style="list-style-type: none"> <li>● Adjust V. Hold volume (VR403) so that the V.Sync and blanking are appeared as shown above.</li> <li>● Adjust VR401 so that the V. Sync and blanking levels are same as shown above.</li> </ul>
6	Deflection Yoke	Stear Step 1.0Vp-p	Internal Monitor Screen	Deflection Yoke	 <ul style="list-style-type: none"> <li>● Loosen the DY fixation screw and adjust Deflection Yoke so that the slope of the raster is as shown above.</li> </ul>

## VII. CLASSIFICATION OF VARIOUS P.C BOARDS

### 7-1 P. C BOARD TITLES

P. C Board Title		Remarks
MAIN AMP/POWER	P. C BOARD	OLD
MAIN AMP/POWER	P. C BOARD	NEW
CONTROL	P. C BOARD	[J] OLD
CONTROL	P. C BOARD	[J] NEW
CONTROL	P. C BOARD	[U] [EA] OLD
CONTROL	P. C BOARD	[U] [EA] NEW
CONTROL	P. C BOARD	[EK] [EO] [S] OLD
CONTROL	P. C BOARD	[EK] [EO] [S] NEW
AUDIO	P. C BOARD	[J] OLD
AUDIO	P. C BOARD	[J] NEW
AUDIO	P. C BOARD	[EA] [EK] [EO] [S] [U] OLD
AUDIO	P. C BOARD	[EA] [EK] [EO] [S] [U] NEW
VIDEO	P. C BOARD	OLD
VIDEO	P. C BOARD	NEW
MONITOR	P. C BOARD	OLD
MONITOR	P. C BOARD	NEW
MAIN VR	P. C BOARD	OLD
MAIN VR	P. C BOARD	NEW
TONE CONTROL	P. C BOARD	
HI-FI	P. C BOARD	[J]
JACK	P. C BOARD	OLD
JACK	P. C BOARD	NEW
FUNCTION	P. C BOARD	
FILTER	P. C BOARD	[J]
FILTER	P. C BOARD	[A] [C]
FILTER	P. C BOARD	[V]
SPEAKER	P. C BOARD	EXCEPT [V] MODEL
SPEAKER	P. C BOARD	[V]



## 7-2. COMPOSITION OF VARIOUS P. C BOARDS

### 1) MAIN AMP/POWER P. C BOARD (OLD)

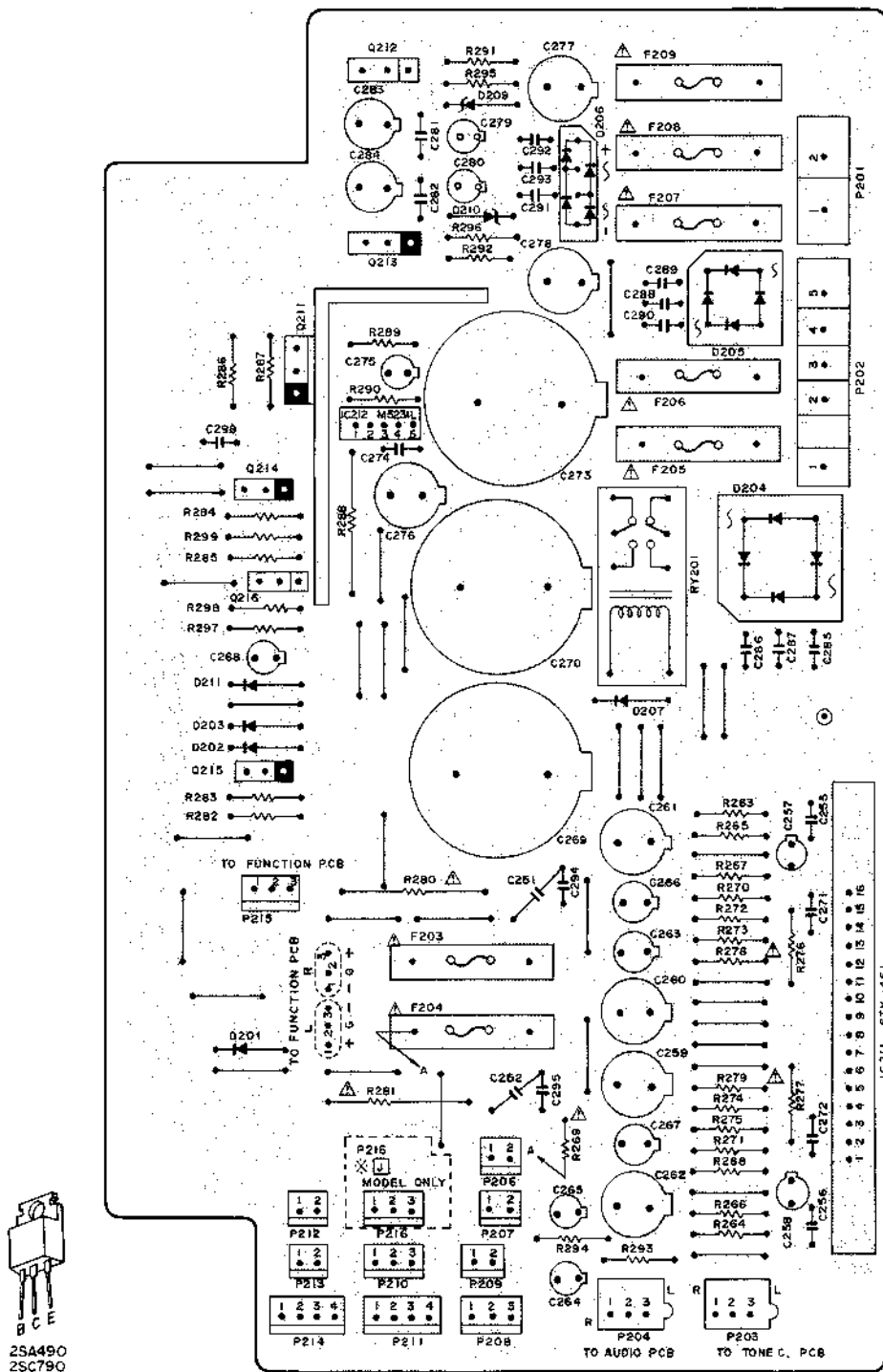

MAIN AMP / POWER PCB (OLD)

- P206 TO RF MODULATOR
- P207 TO SWITCH
- P209 TO MONITOR PCB
- P208 TO VIDEO PCB
- P210 TO VIDEO PCB
- P211 TO AUDIO PCB
- P212 TO SWITCH
- P213 TO MAIN-VR PCB
- P214 TO TONE C. PCB

- Q211, 213 ----- 2SA490-Y
- Q212 ----- 2SC790-Y
- Q214, 215 ----- 2SA1115 O,E
- Q216 ----- 2SC2603 D,E



WARNING:  $\Delta$  INDICATES SAFETY CRITICAL COMPONENTS. FOR CONTINUED SAFETY, REPLACE SAFETY CRITICAL COMPONENTS ONLY WITH MANUFACTURER'S RECOMMENDED PARTS.

AVERTISSEMENT:  $\Delta$  IL INDIQUE LES COMPOSANTS CRITIQUES DE SÉCURITÉ. POUR MAINTENIR LE DEGRÉ DE SÉCURITÉ DE L'APPAREIL, NE REMPLACER QUE DES PIÈCES RECOMMANDÉES PAR LE FABRICANT.

## 2) MAIN AMP/POWER P. C BOARD (NEW)

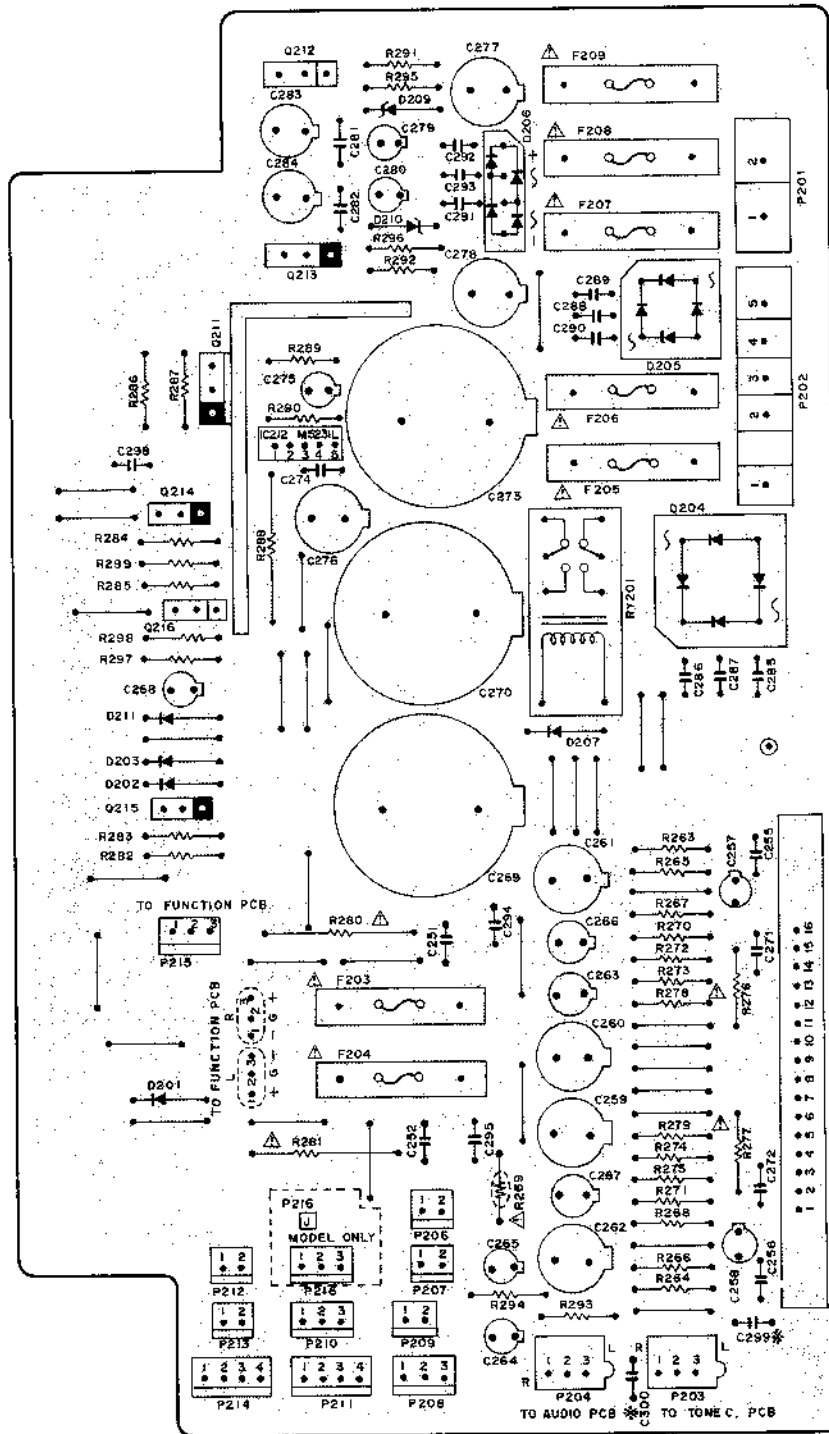

MAIN AMP / POWER PCB (NEW)

- |      |                 |           |                  |
|------|-----------------|-----------|------------------|
| P206 | TO RF MODULATOR | Q211, 213 | -----2SA490-Y    |
| P207 | TO SWITCH       | Q212      | -----2SC790-Y    |
| P209 | TO MONITOR PCB  | Q214, 215 | -----2SA1115 D,E |
| P208 | TO VIDEO PCB    | Q216      | -----2SC2603 D,E |
| P210 | TO VIDEO PCB    |           |                  |
| P211 | TO AUDIO PCB    |           |                  |
| P212 | TO SWITCH       |           |                  |
| P213 | TO MAIN-VR PCB  |           |                  |
| P214 | TO TONE C. PCB  |           |                  |
- MARKED \* CAPACITORS ARE USED FOR  MODEL ONLY

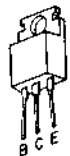

2SA490  
2SC790



2SA1115  
2SC2603

WARNING:  $\Delta$  INDICATES SAFETY CRITICAL COMPONENTS. FOR CONTINUED SAFETY, REPLACE SAFETY CRITICAL COMPONENTS ONLY WITH MANUFACTURER'S RECOMMENDED PARTS.

AVERTISSEMENT:  $\Delta$  IL INDIQUE LES COMPOSANTS CRITIQUES DE SÉCURITÉ. POUR MAINTENIR LE DEGRÉ DE SÉCURITÉ DE L'APPAREIL, NE REMPLACER QUE DES PIÈCES RECOMMANDÉES PAR LE FABRICANT.

### 3) CONTROL P. C BOARD [J] MODEL (OLD)

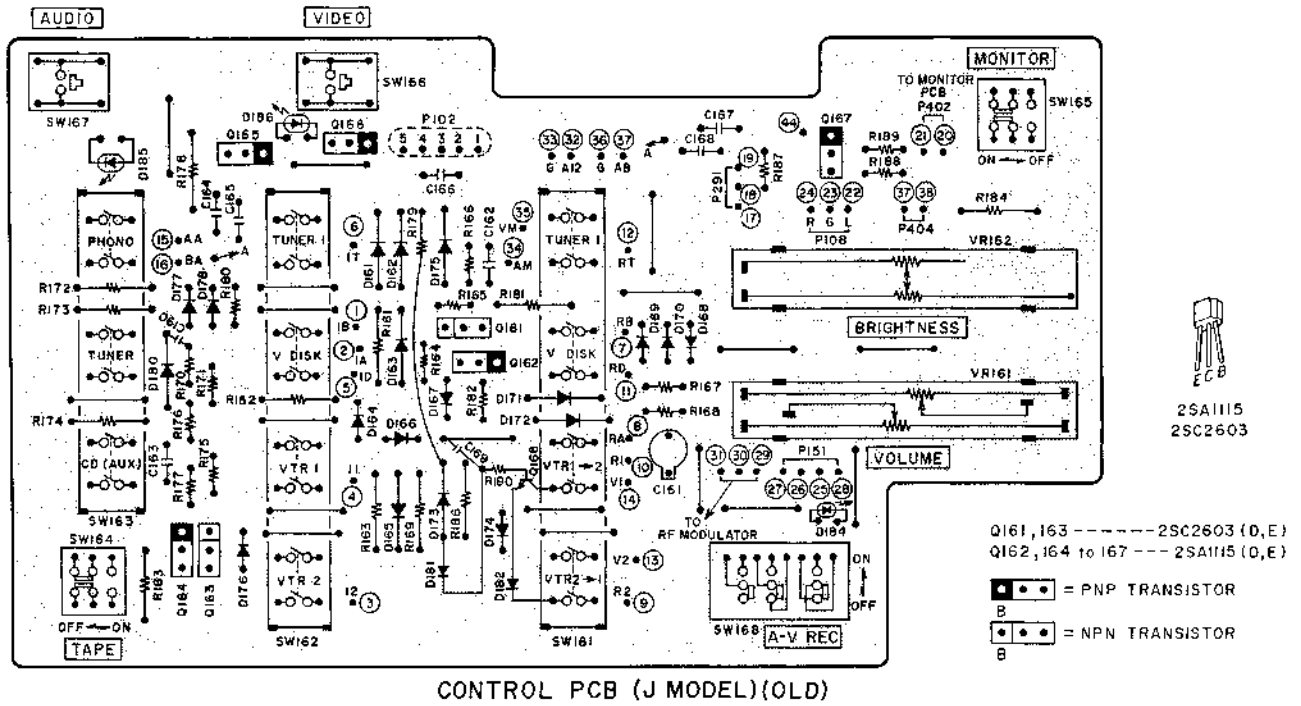

### 4) CONTROL P. C BOARD [J] MODEL (NEW)

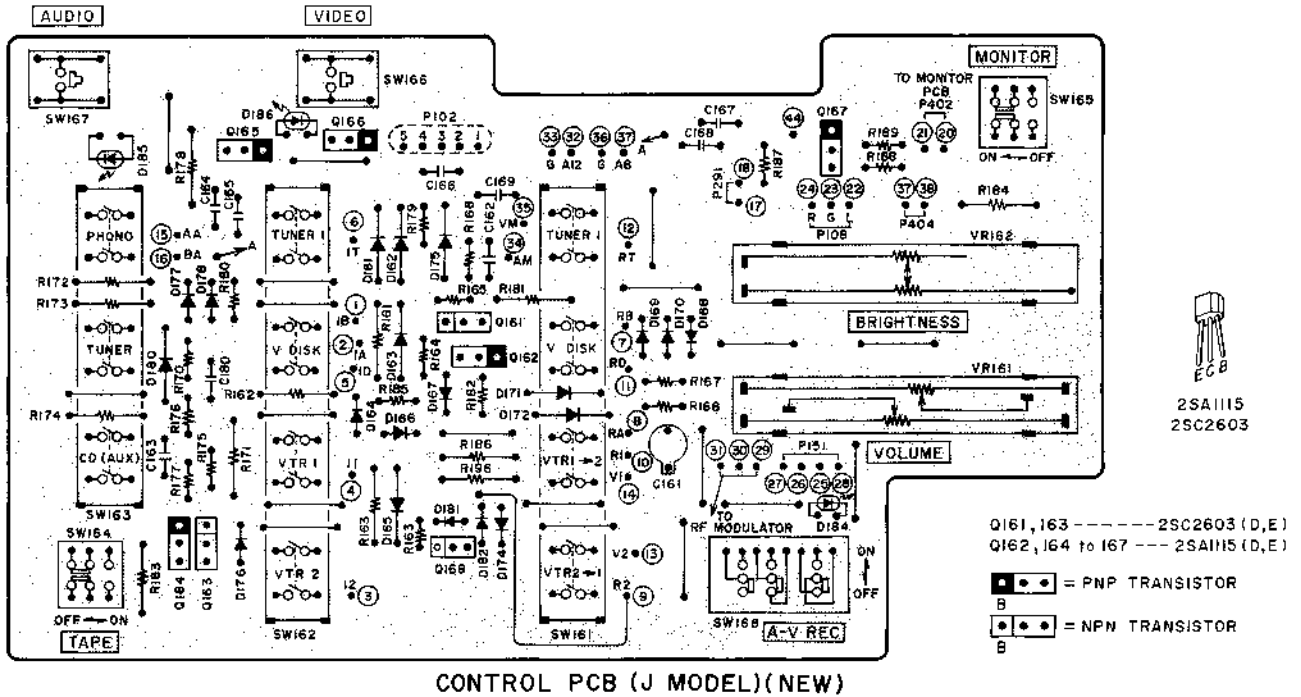

5) CONTROL P. C BOARD [EA], [U] MODELS (OLD)

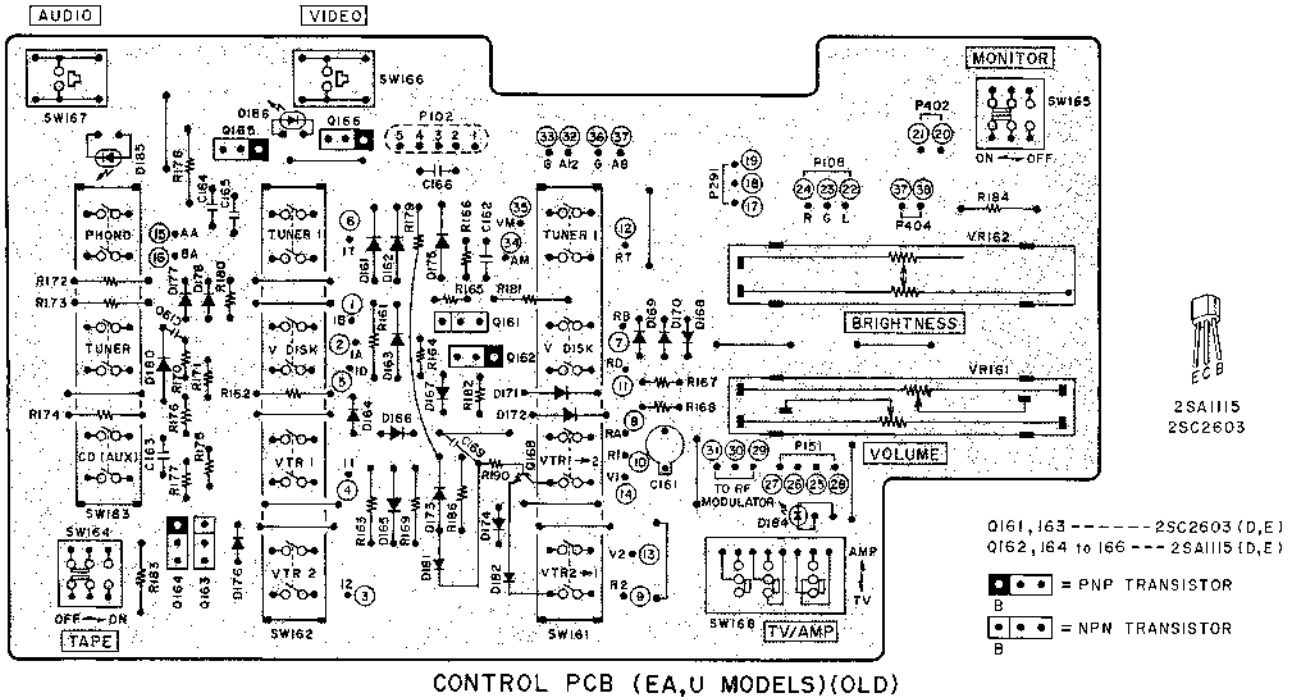

6) CONTROL P. C BOARD [EA], [U] MODELS (NEW)

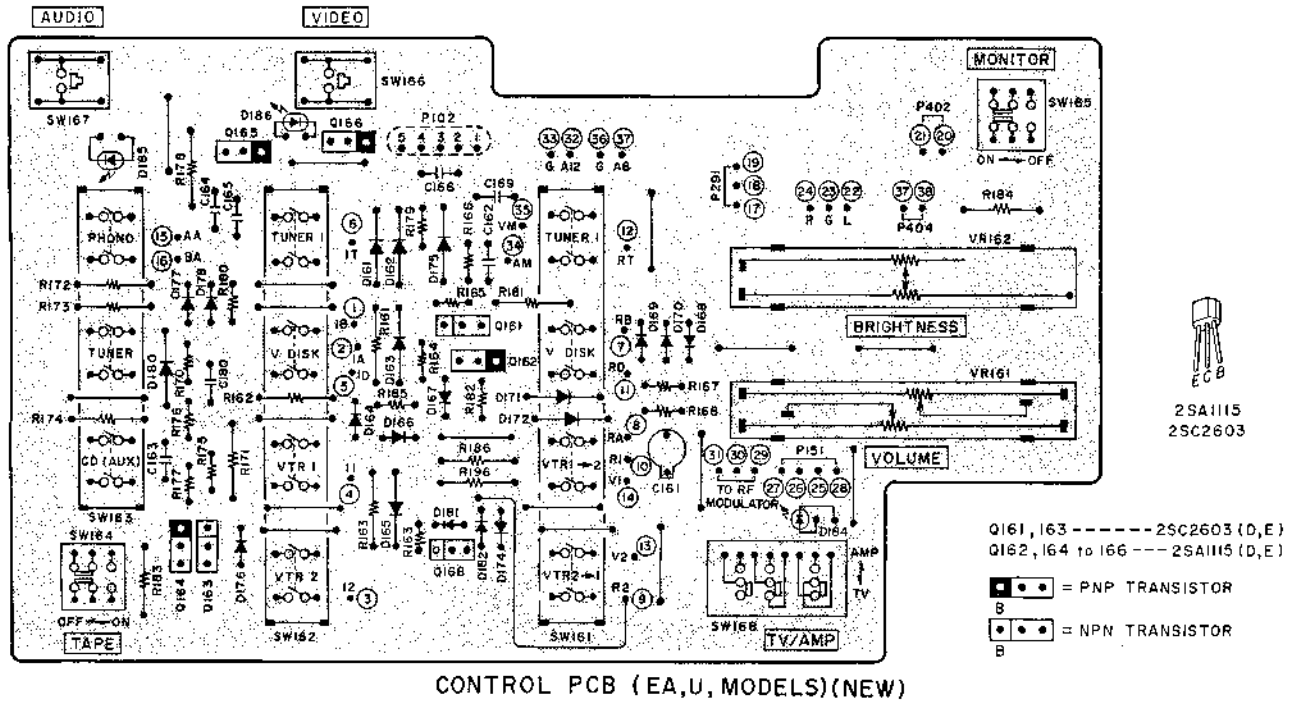

7) CONTROL P. C BOARD **EK**, **EO**, **S** MODELS (OLD)

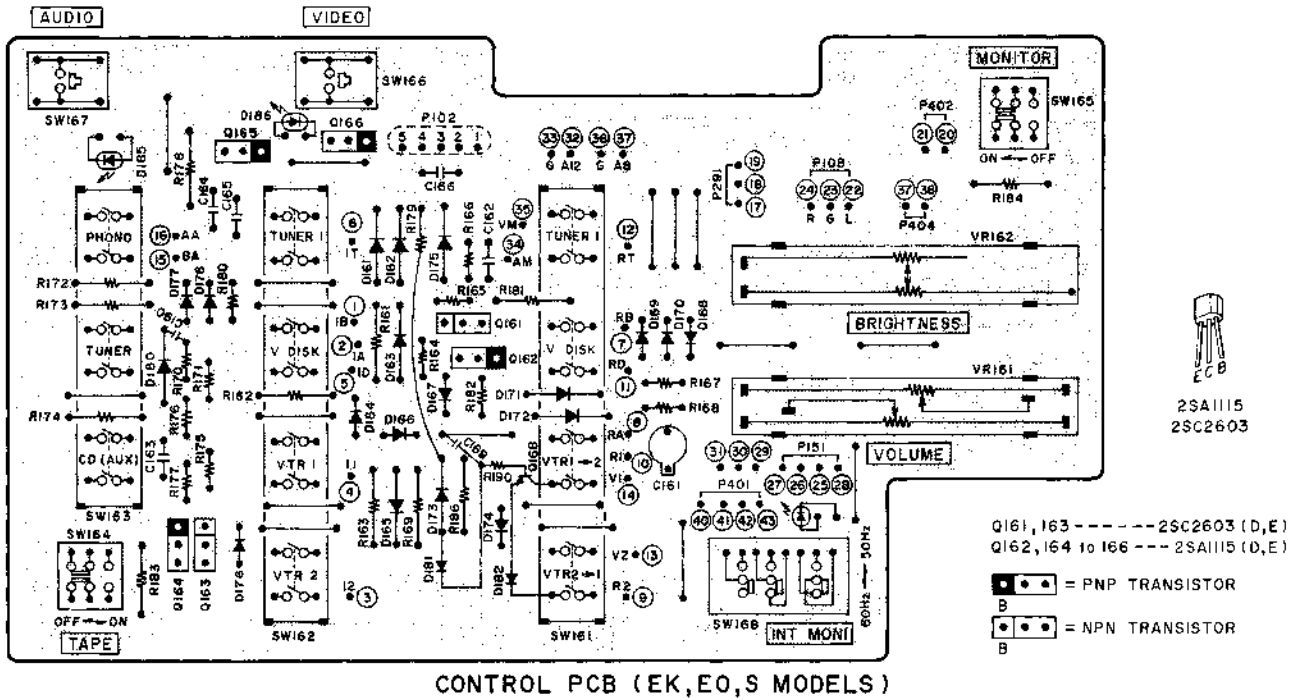

8) CONTROL P. C BOARD **EK**, **EO**, **S** MODELS (NEW)

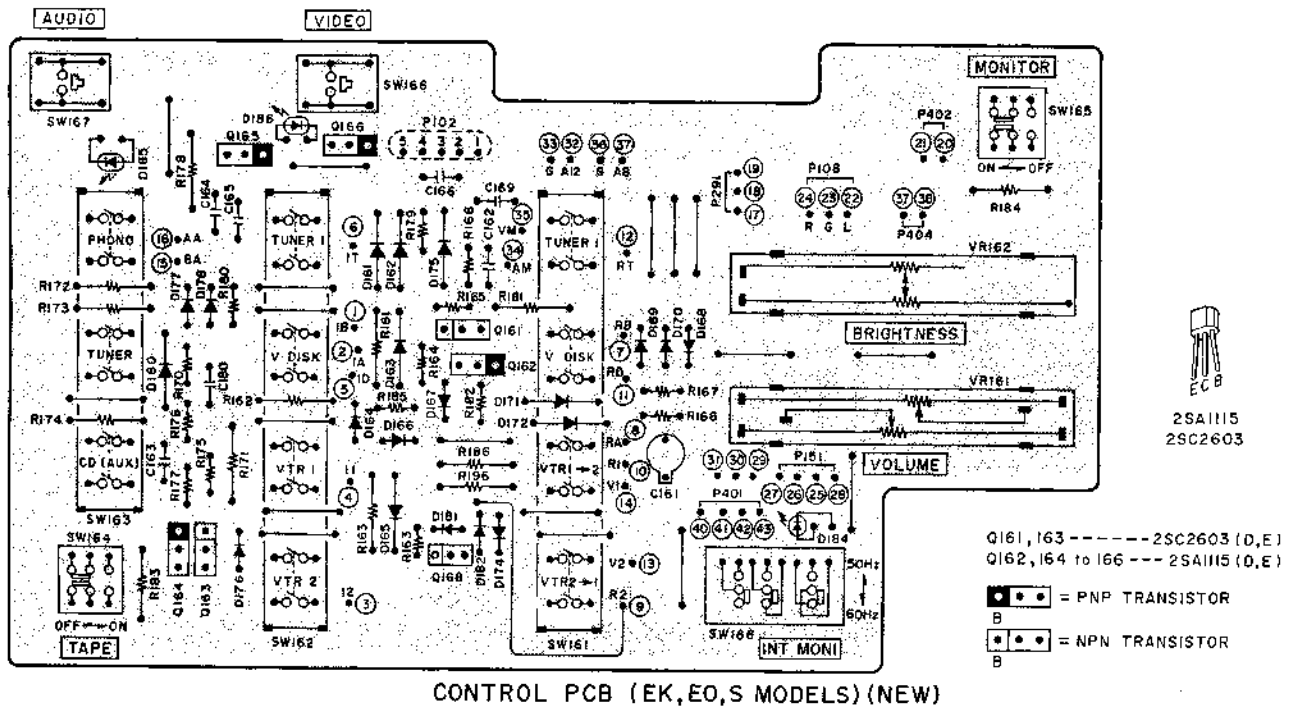

# 9) AUDIO P.C BOARD (J) MODEL (OLD)

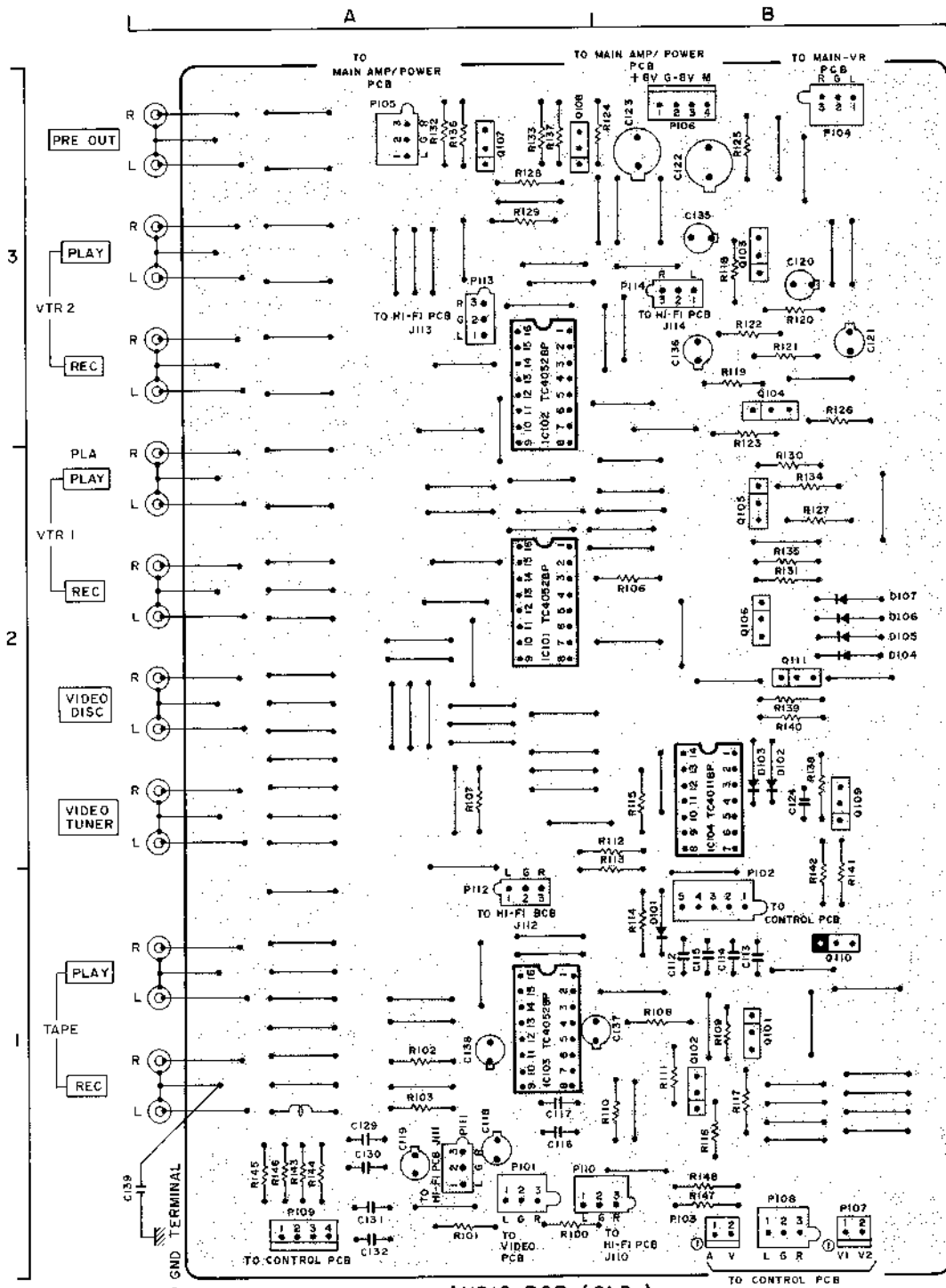

**AUDIO PCB (OLD)  
(J MODEL)**

• Location of IC'S

- IC101-----A2
- IC102-----A3
- IC103-----A1
- IC104-----B2

• Location of Transistors

- Q101-----B1
- Q102-----B1
- Q103-----B3
- Q104-----B3
- Q105-----B2
- Q106-----B2
- Q107-----A3
- Q108-----A3
- Q109-----B2
- Q110-----B1
- Q111-----B2

• Location of Connectors

- PI01-----A1
- PI02-----B1
- PI03-----B1
- PI04-----B3
- PI05-----A3
- PI06-----B3
- PI07-----B1
- PI08-----B1
- PI09-----A1

• Transistors

- Q101,102,103,104 .....2SC2602(G)
- Q105,106,107,108,109,111 .....2SC2603(D,E)
- Q110 .....2SA1115(D,E)

••• = PNP TRANSISTOR

B C E

••• = NPN TRANSISTOR

B C E



2SA1115  
2SC2602  
2SC2603

10) AUDIO P. C BOARD [J] MODEL (NEW)

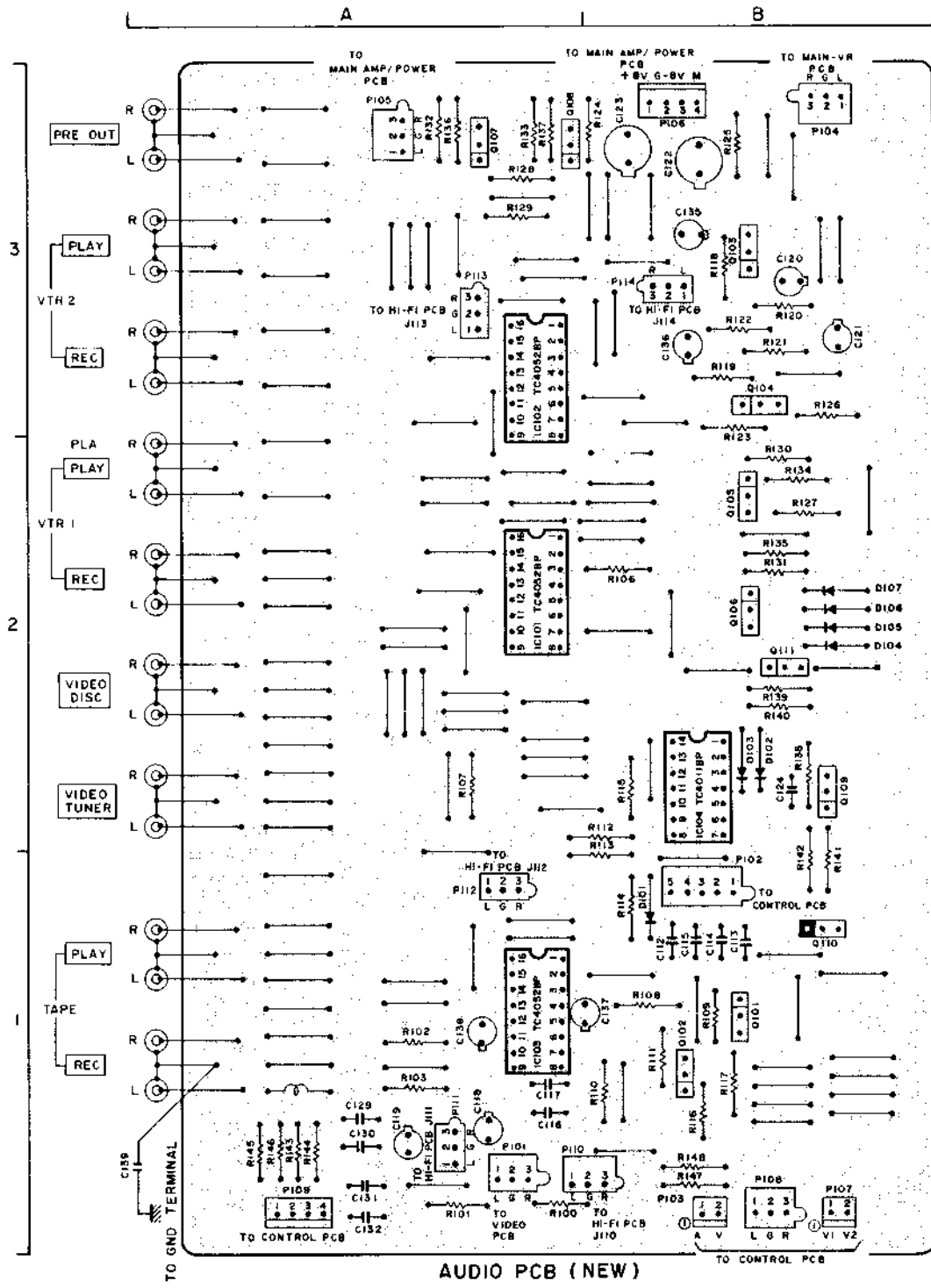

AUDIO PCB (NEW)  
(J MODEL)

• Location of IC'S

- IC101.....A2
- IC102.....A3
- IC103.....A1
- IC104.....B2

• Location of Transistors

- Q101.....B1    Q107.....A3
- Q102.....B1    Q108.....A3
- Q103.....B3    Q109.....B2
- Q104.....B3    Q110.....B1
- Q105.....B2    Q111.....B2
- Q106.....B2

• Location of Connectors

- P101.....A1
- P102.....B1
- P103.....B1
- P104.....B3
- P105.....A3
- P106.....B3
- P107.....B1
- P108.....B1
- P109.....A1

• Transistors

- Q101,102,103,104 .....2SC2602 (G)
- Q105,106,107,108,109,111.....2SC2603 (D,E)
- Q110 .....2SA1115 (D,E)

• = PNP TRANSISTOR

B C E

• = NPN TRANSISTOR

B C E



2SA1115  
2SC2602  
2SC2603

# 11) AUDIO P.C BOARD EA, EK, EO, S, U MODELS (OLD)

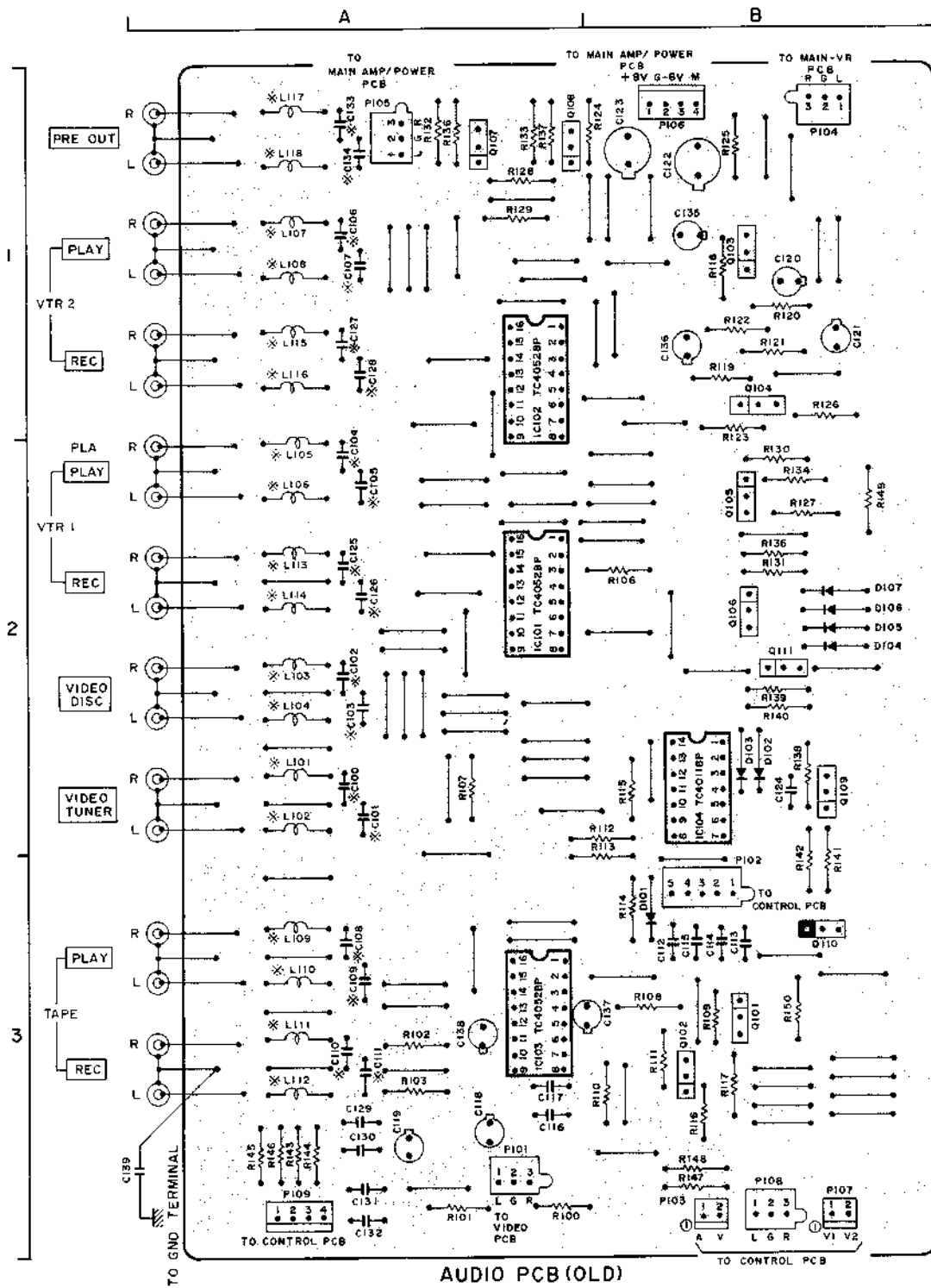

## EA, EK, EO, S, U MODELS

\* Indicated \* Capacitors are used for [V] model only.  
 • Indicated \* Coils are used for [V] model only. Other models are used Jump wires.

- Location of IC'S
- IC101.....A2
- IC102.....A3
- IC103.....A1
- IC104.....B2

- Location of Transistors
- Q101.....B1    Q107.....A3
- Q102.....B1    Q108.....A3
- Q103.....B3    Q109.....B2
- Q104.....B3    Q110.....B1
- Q105.....B2    Q111.....B2
- Q106.....B2

- Location of Connectors
- P101.....A1
- P102.....B1
- P103.....B1
- P104.....B3
- P105.....A3
- P106.....B3
- P107.....B1
- P108.....B1
- P109.....A1

- Transistors
- Q101,102,103,104.....2SC2602 (G)
- Q105,106,107,108,109,111.....2SC2603 (D,E)
- Q110.....2SA1115 (D,E)

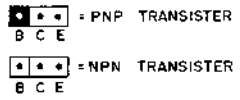



12) AUDIO P. C BOARD [EA], [EK], [EO], [S], [U] MODELS (NEW)

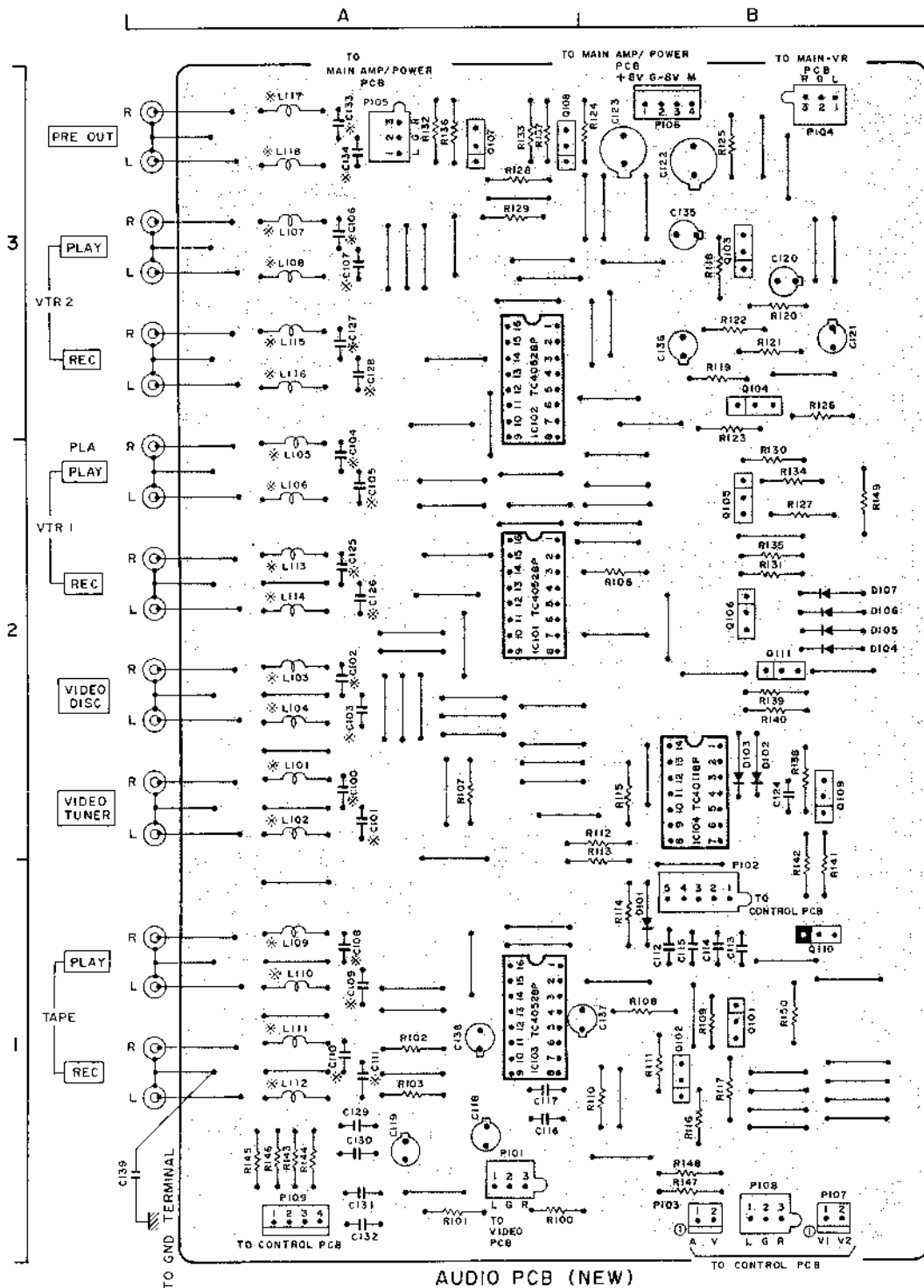

AUDIO PCB (NEW)

EA, EK, EO, S, U MODELS

- Indicated \* Capacitors are used for [V] model only.
- Indicated \* Coils are used for [V] model only. Other models are used Jump wires.

- Location of IC'S
- IC101-----A2
- IC102-----A3
- IC103-----A1
- IC104-----B2

- Location of Transistors
- Q101-----B1 Q107-----A3
- Q102-----B1 Q108-----A3
- Q103-----B3 Q109-----B2
- Q104-----B3 Q110-----B1
- Q105-----B2 Q111-----B2
- Q106-----B2

- Location of Connectors
- PI01-----A1
- PI02-----B1
- PI03-----B1
- PI04-----B3
- PI05-----A3
- PI06-----B3
- PI07-----B1
- PI08-----B1
- PI09-----A1

- Transistors
- Q101, 102, 103, 104 ----- 25C2602 (G)
- Q105, 106, 107, 108, 109, 111 ----- 25C2603 (D, E)
- Q110 ----- 25A1115 (D, E)

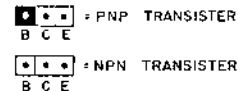

# 13) VIDEO P. C BOARD (OLD)

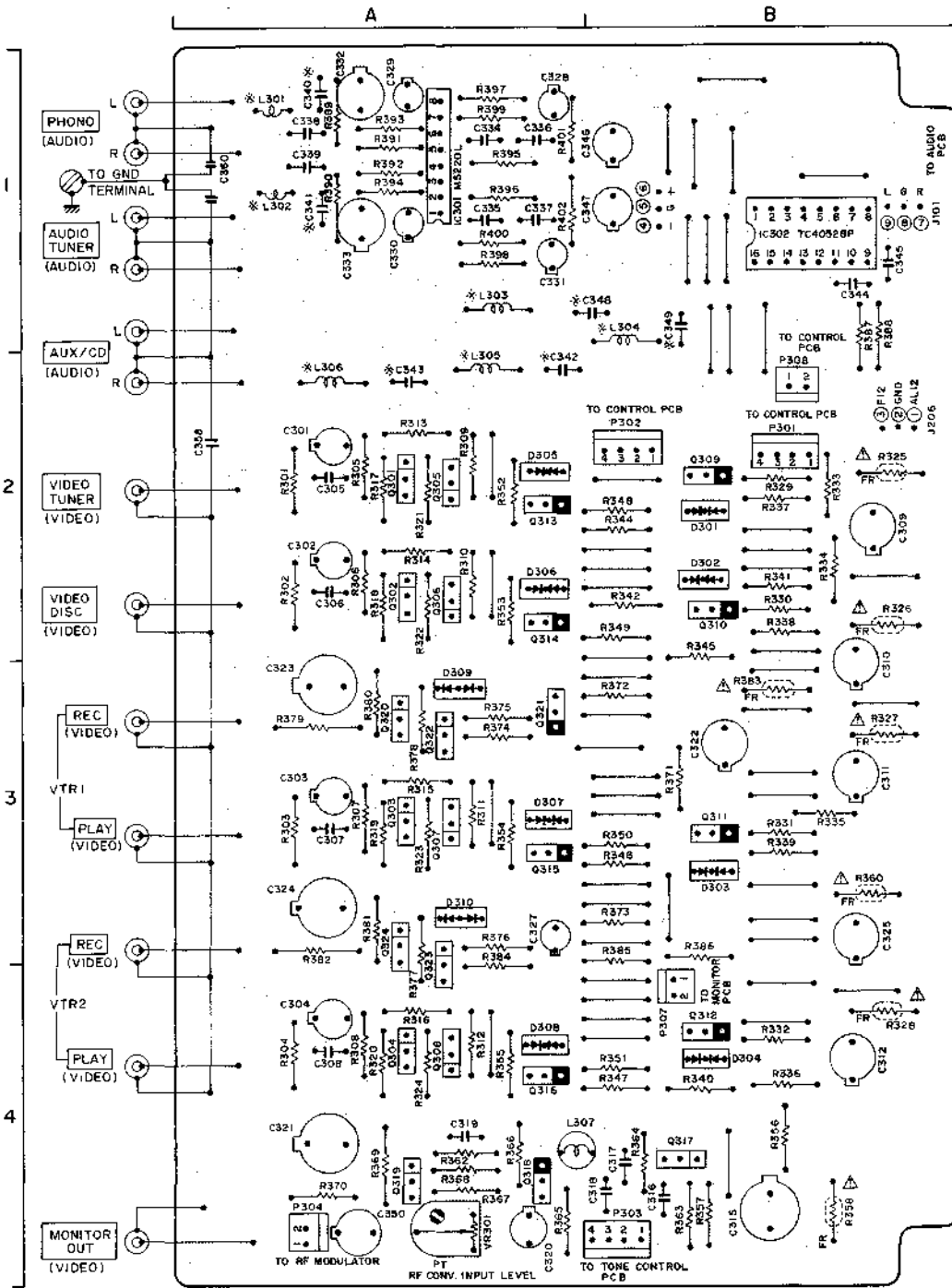

VIDEO PCB (OLD)

• Indicated \* Capacitors are used for [V] model only.

• Indicated \* Coils are used for [V] model only. Other models are used jump wires.

WARNING: ⚠ INDICATES SAFETY CRITICAL COMPONENTS FOR CONTINUED SAFETY. REPLACE SAFETY CRITICAL COMPONENTS ONLY WITH MANUFACTURER'S RECOMMENDED PARTS.

AVERTISSEMENT: ⚠ ILL INDIQUE LES COMPOSANTS CRITIQUES DE SÉCURITÉ POUR MAINTENIR LE DEGRÉ DE SÉCURITÉ DE L'APPAREIL. NE REMPLACER QUE DES PIÈCES RECOMMANDÉES PAR LE FABRICANT.

• Location of IC's  
IC301 ---- A4  
IC302 ---- B4

• Location of Connectors  
P301 ---- B3 P303 ---- B1  
P302 ---- B3 P304 ---- A1

• Location of Transistors  
Q301 ---- A3 Q313 ---- A3  
Q302 ---- A3 Q314 ---- A3  
Q303 ---- A2 Q315 ---- A2  
Q304 ---- A1 Q316 ---- A1  
Q305 ---- A3 Q317 ---- B1  
Q306 ---- A3 Q318 ---- A1  
Q307 ---- A2 Q319 ---- A1  
Q308 ---- A1 Q320 ---- A2  
Q309 ---- B3 Q321 ---- A2  
Q310 ---- B3 Q322 ---- A2  
Q311 ---- B2 Q324 ---- A2  
Q312 ---- B1

• Transistors  
Q301 to 308, 317, 322, 323 ---- 2SC2603 (D,E)  
Q309 to 316, 318, 321 ---- 2SA1115 (D,E)  
Q319, 320, 324 ---- 2SC1210 (D,E)

• = NPN TRANSISTOR  
B C E

• = PNP TRANSISTOR  
B C E



2SA1115  
2SC2603



2SC1210

# 14) VIDEO P. C BOARD (NEW)

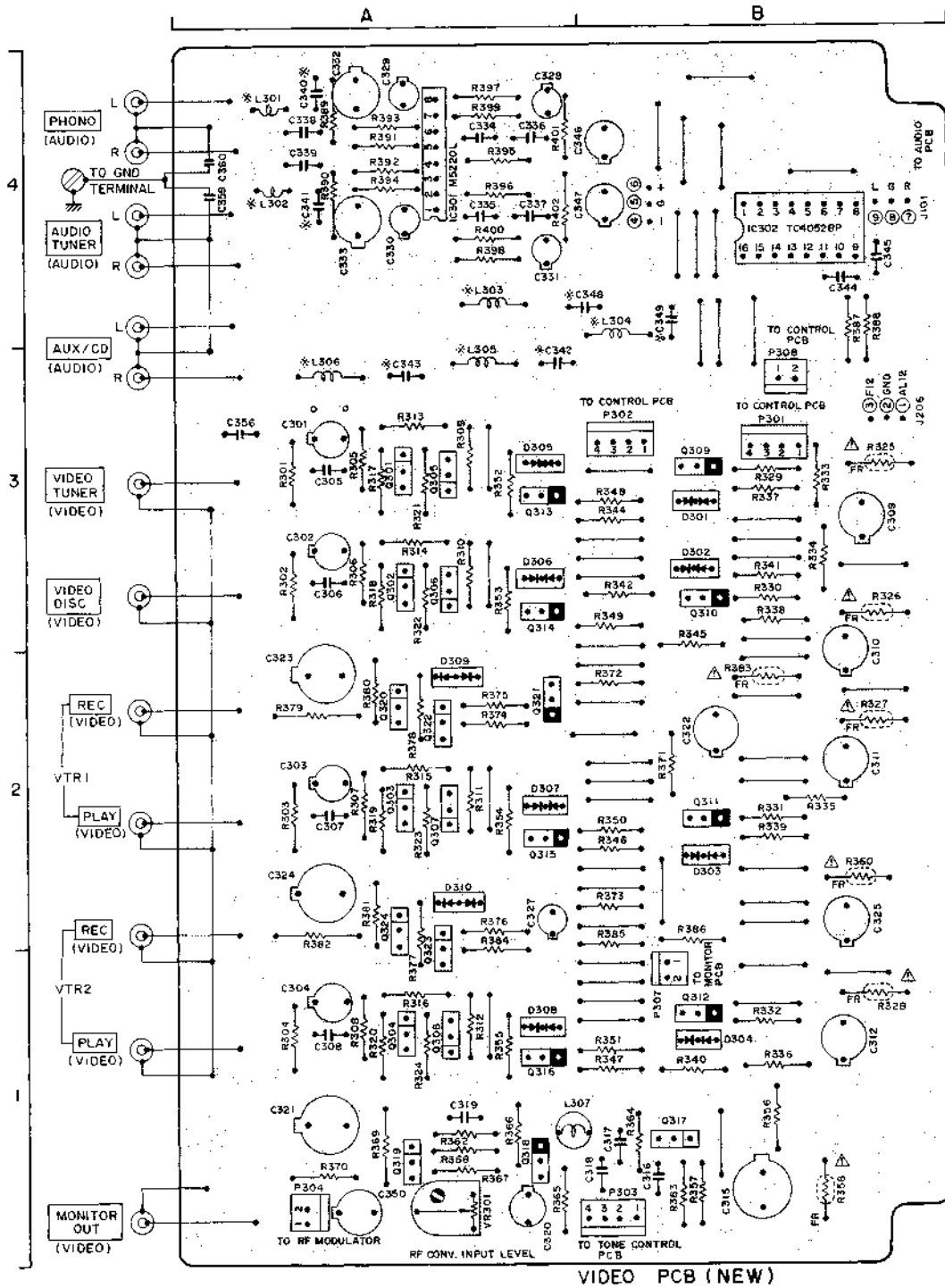

VIDEO PCB (NEW)

- Indicated \* Capacitors are used for [V] model only.
- Indicated \* Coils are used for [V] model only. Other models are used jump wires.

WARNING ⚠ INDICATES SAFETY CRITICAL COMPONENTS. FOR CONTINUED SAFETY, REPLACE SAFETY CRITICAL COMPONENTS ONLY WITH MANUFACTURER'S RECOMMENDED PARTS.  
 AVERTISSEMENT ⚠ IL INDIQUE LES COMPOSANTS CRITIQUES DE SÉCURITÉ. POUR MAINTENIR LE DEGRÉ DE SÉCURITÉ DE L'APPAREIL, NE REMPLACER QUE DES PIÈCES RECOMMANDÉES PAR LE FABRICANT.

- Location of IC'S
- IC301.....A4
- IC302.....B4

- Location of Connectors
- P301.....B3 P303.....B1
- P302.....B3 P304.....A1

- Location of Transistors
- Q301.....A3 Q313.....A3
- Q302.....A3 Q314.....A3
- Q303.....A2 Q315.....A2
- Q304.....A1 Q316.....A1
- Q305.....A3 Q317.....B1
- Q306.....A3 Q318.....A1
- Q307.....A2 Q319.....A1
- Q308.....A1 Q320.....A2
- Q309.....B3 Q321.....A2
- Q310.....B3 Q322.....A2
- Q311.....B2 Q324.....A2
- Q312.....B1

- Transistors
- Q301 to 308, 317, 322, 323.....25C2603 (D,E)
- Q309 to 316, 318, 321.....25A1115 (D,E)
- Q319, 320, 324.....25C1210 (D,E)

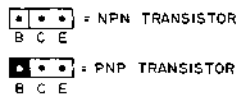

25A1115  
25C2603



25C1210

## 15) MONITOR P. C BOARD (OLD)

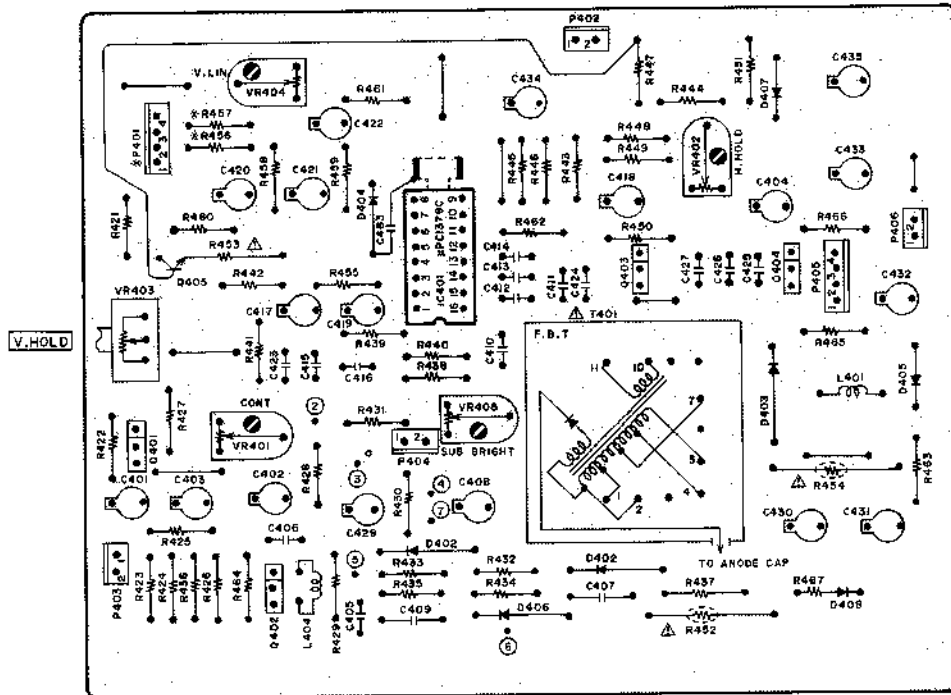

### MONITOR PCB (OLD)

- MARKED \* PARTS ARE USED FOR EK EO S MODELS  
OTHER MODELS ARE NOT USED

WARNING:  $\Delta$  INDICATES SAFETY CRITICAL COMPONENTS FOR CONTINUED SAFETY.  
REPLACE SAFETY CRITICAL COMPONENTS ONLY WITH MANUFACTURER'S  
RECOMMENDED PARTS

AVERTISSEMENT:  $\Delta$  IL INDIQUE LES COMPOSANTS CRITIQUES DE SÉCURITÉ.  
POUR MAINTENIR LE DEGRÉ DE SÉCURITÉ DE L'APPAREIL  
NE REMPLACER QUE DES PIÈCES RECOMMANDÉES PAR LE FABRICANT

Q401,403 ---- 2SC2603(D,E)  
Q402 ---- 2SC2610  
Q404 ---- 2SD763

$\square$  = NPN TRANSISTOR



2SC2610  
2SD763



2SC2603

## 16) MONITOR P. C BOARD (NEW)

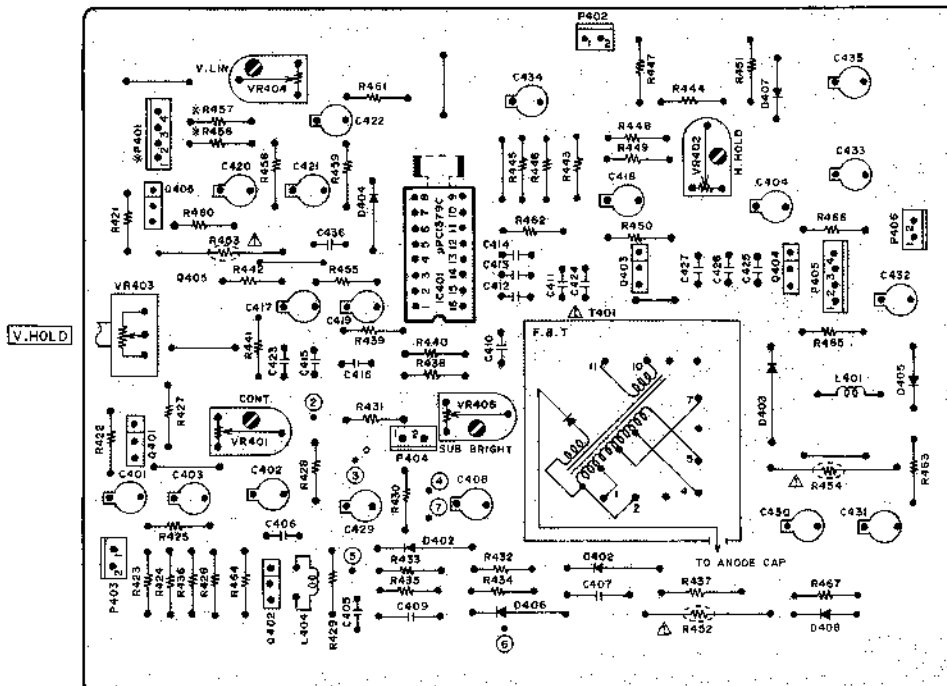

### MONITOR PCB (NEW)

- MARKED \* PARTS ARE USED FOR EK EO S MODELS  
OTHER MODELS ARE NOT USED

WARNING:  $\Delta$  INDICATES SAFETY CRITICAL COMPONENTS FOR CONTINUED SAFETY.  
REPLACE SAFETY CRITICAL COMPONENTS ONLY WITH MANUFACTURER'S  
RECOMMENDED PARTS

AVERTISSEMENT:  $\Delta$  IL INDIQUE LES COMPOSANTS CRITIQUES DE SÉCURITÉ.  
POUR MAINTENIR LE DEGRÉ DE SÉCURITÉ DE L'APPAREIL  
NE REMPLACER QUE DES PIÈCES RECOMMANDÉES PAR LE FABRICANT

Q401,403 ---- 2SC2603(D,E)  
Q402 ---- 2SC2610  
Q404 ---- 2SD763  
Q405 ---- 2SC1210

$\square$  = NPN TRANSISTOR



2SC2610  
2SD763



2SC2603



2SC1210

17) MAIN-VR P. C BOARD (OLD)

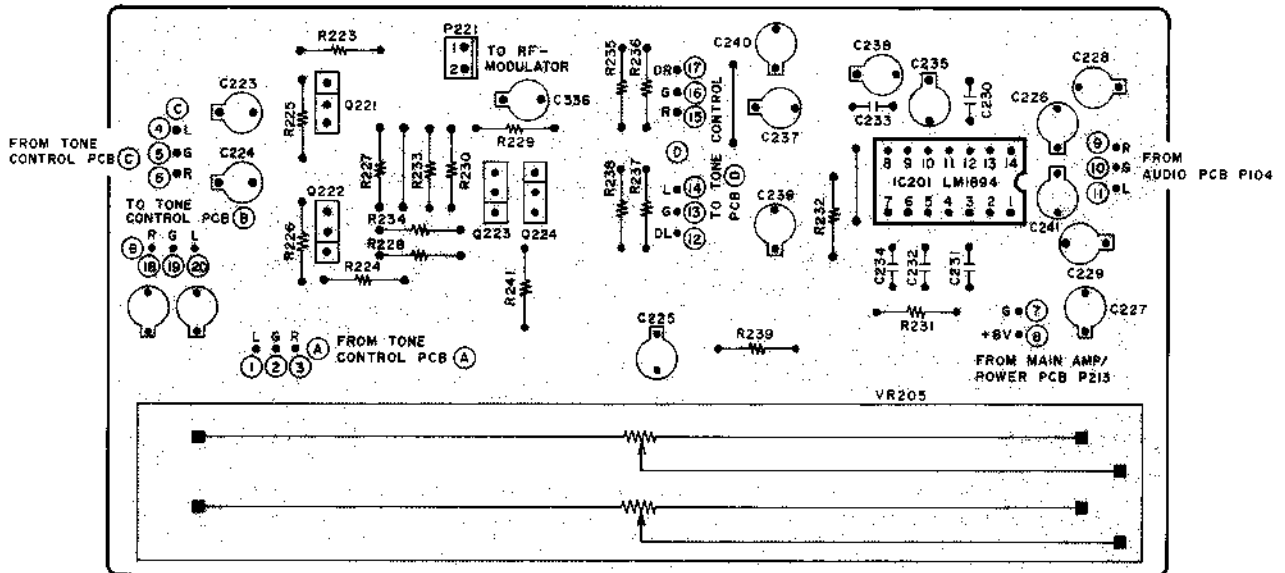

MAIN - VR PCB (OLD)



2SA1115  
2SC2603

Q221, 222, 224 --- 2SA1115 (D, E)  
Q223 ----- 2SC2603 (D, E)

18) MAIN-VR P. C BOARD (NEW)

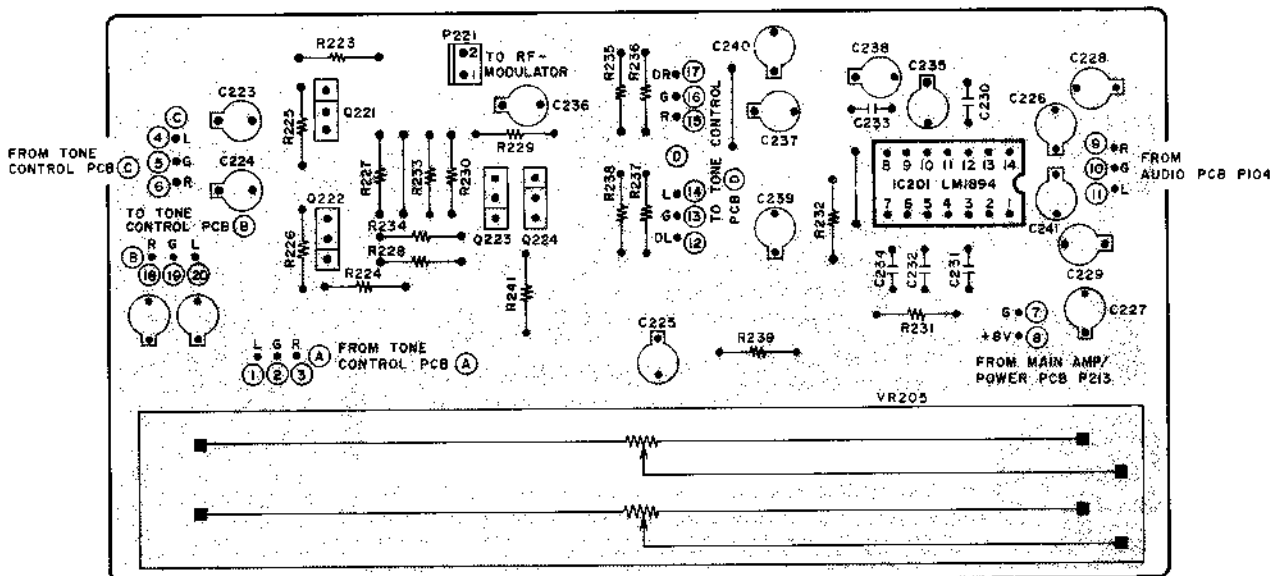

MAIN - VR PCB (NEW)



2SA1115  
2SC2603

Q221, 222, 224 --- 2SA1115 (D, E)  
Q223 ----- 2SC2603 (D, E)

19) TONE CONTROL P. C BOARD

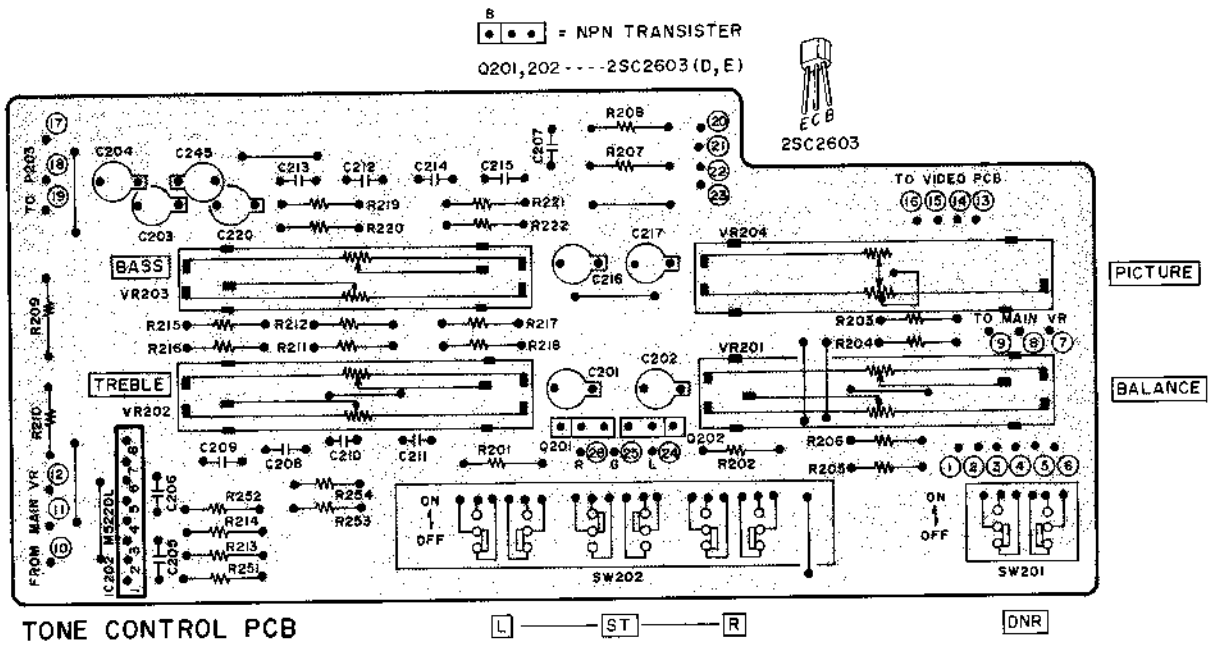

20) HI-FI P. C BOARD J MODEL ONLY

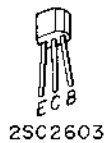
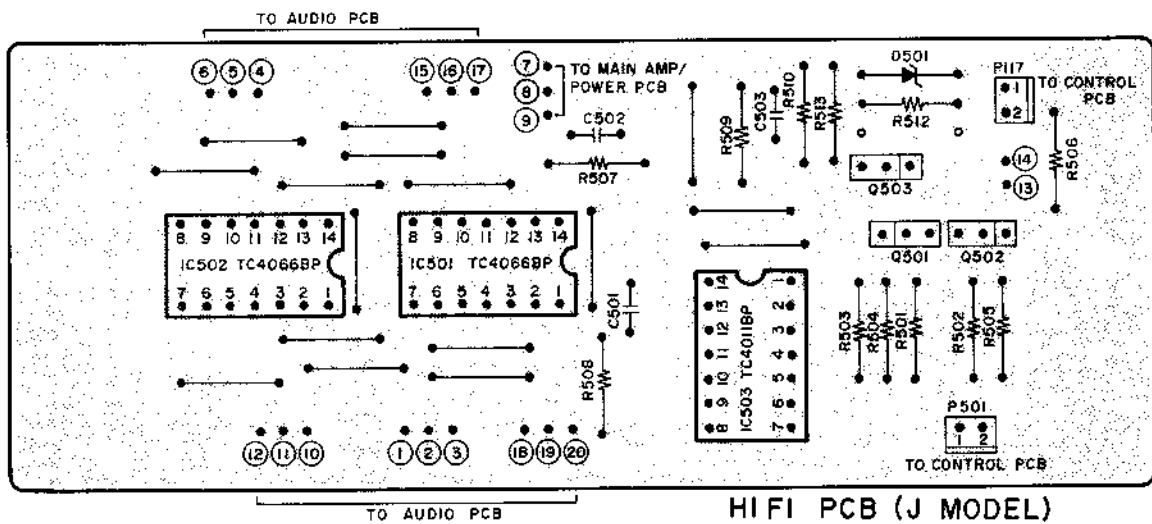

Q501, 502, 503 ---- 2SC2603 (D, E)

21) JACK P. C BOARD (OLD)

22) JACK P. C BOARD (NEW)

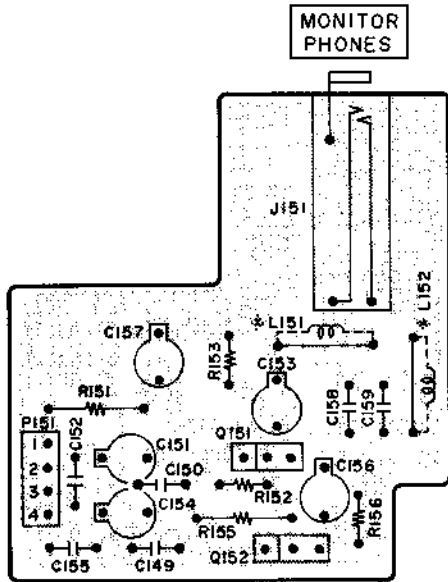

JACK PCB (OLD)

MARKED \* COILS ARE USED FOR [V] MODEL ONLY. OTHER MODELS ARE USED JUMP WISES. C149, C150 ARE NOT USED FOR [J] MODEL.

= NPN TRANSISTOR  
B

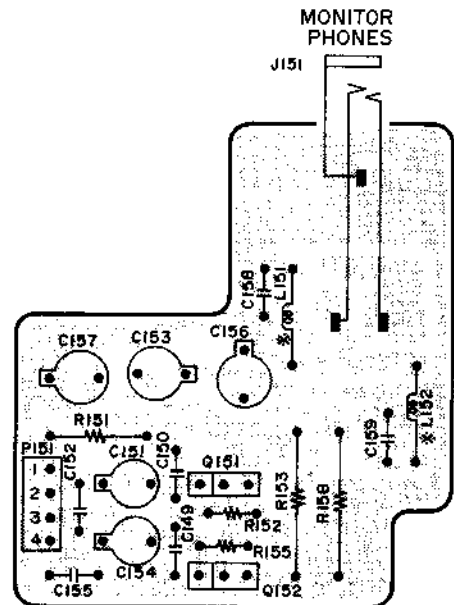

JACK PCB (NEW)

MARKED \* COILS ARE USED FOR [V] MODEL ONLY. OTHER MODELS ARE USED JUMP WISES. C149, C150 ARE NOT USED FOR [J] MODEL.

= NPN TRANSISTOR  
B

23) FUNCTION P. C BOARD

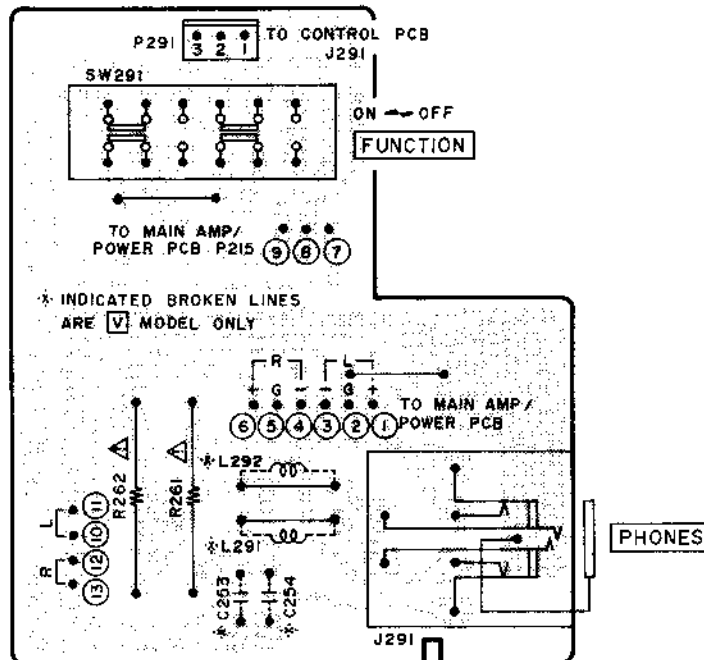

FUNCTION PCB

WARNING:  $\Delta$  INDICATES SAFETY CRITICAL COMPONENTS FOR CONTINUED SAFETY, REPLACE SAFETY CRITICAL COMPONENTS ONLY WITH MANUFACTURER'S RECOMMENDED PARTS

AVERTISSEMENT:  $\Delta$  IL INDIQUE LES COMPOSANTS CRITIQUES DE SÉCURITÉ. POUR MAINTENIR LE DEGRÉ DE SÉCURITÉ DE L'APPAREIL, NE REMPLACER QUE DES PIÈCES RECOMMANDÉES PAR LE FABRICANT

24) FILTER P. C BOARD [J] MODEL

25) FILTER P. C BOARD [A], [C] MODEL

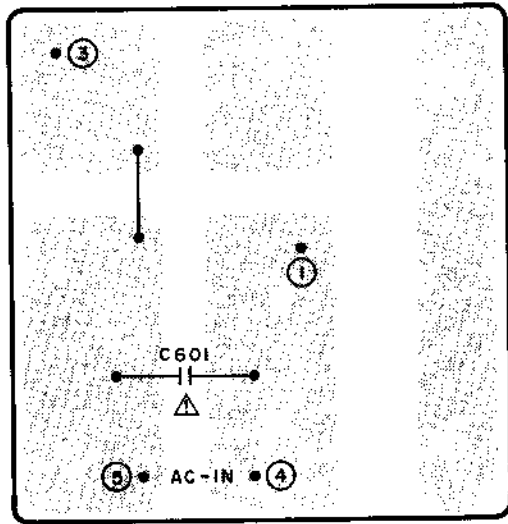

FILTER PCB ( [J] MODEL )

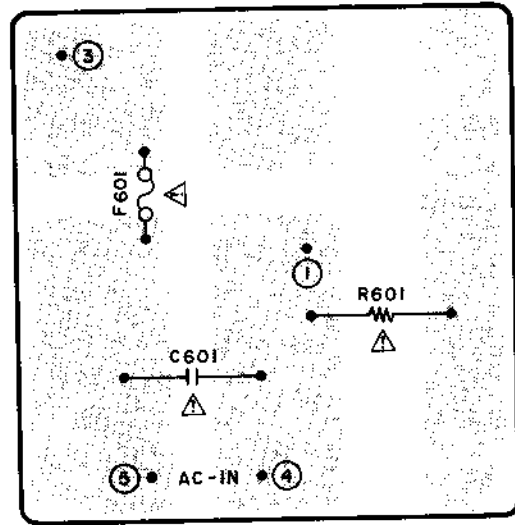

FILTER PCB ( [A] [C] MODEL )

26) FILTER P. C BOARD

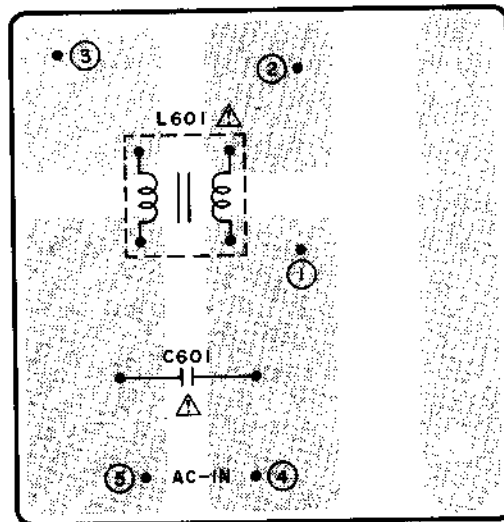

FILTER PCB ( [V] MODEL )

WARNING:  INDICATES SAFETY CRITICAL COMPONENTS FOR CONTINUED SAFETY. REPLACE SAFETY CRITICAL COMPONENTS ONLY WITH MANUFACTURER'S RECOMMENDED PARTS

AVERTISSEMENT:  IL INDIQUE LES COMPOSANTS CRITIQUES DE SÉCURITÉ. POUR MAINTENIR LE DEGRÉ DE SÉCURITÉ DE L'APPAREIL, NE REMPLACER QUE DES PIÈCES RECOMMANDÉES PAR LE FABRICANT



27) SPEAKER P. C BOARD EXCEPT **V** MODEL

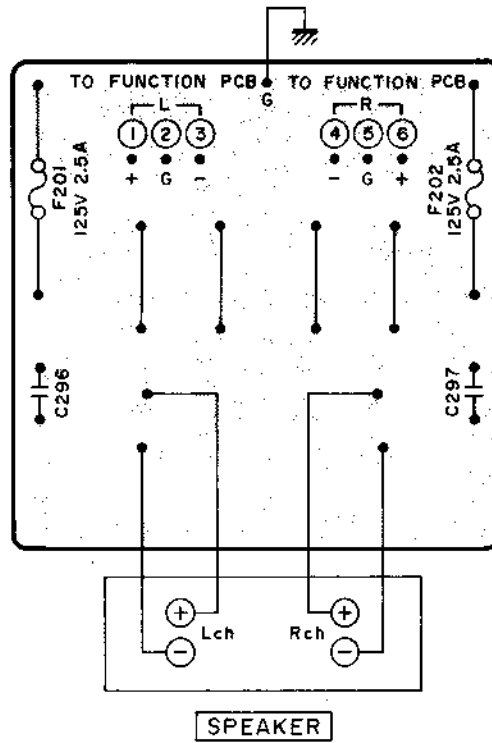

**SPEAKER PCB**  
( EXCEPT **V** MODEL )

28) SPEAKER P. C BOARD **V** MODEL ONLY

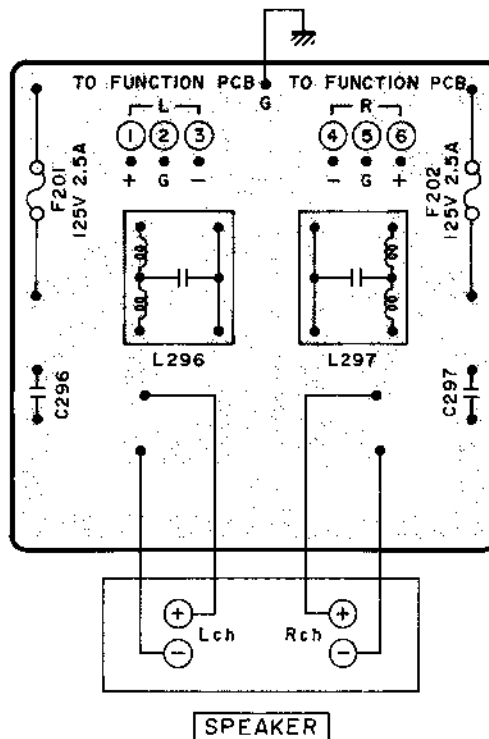

**SPEAKER PCB**  
( **V** MODEL ONLY )

---

SECTION 2

**PARTS LIST**

TABLE OF CONTENTS

<b>RECOMMENDED SPARE PARTS.....</b>	<b>34</b>
1. P. C BOARD BLOCK.....	35
2. VIDEO P. C BOARD BLOCK.....	35
3. POWER & MAIN P. C BOARD BLOCK.....	35
4. AUDIO P. C BOARD BLOCK.....	36
5. CONTROL P. C BOARD BLOCK.....	36
6. MONITOR P. C BOARD BLOCK.....	36
7. MAIN VOLUME P. C BOARD BLOCK.....	36
8. TONE CONTROL P. C BOARD BLOCK.....	36
9. SPEAKER P. C BOARD BLOCK.....	37
10. FUNCTION P. C BOARD BLOCK.....	37
11. JACK P. C BOARD BLOCK.....	37
12. HI-FI P. C BOARD BLOCK.....	37
13. FILTER P. C BOARD BLOCK.....	37
14. POWER & RF BLOCK.....	39
15. ASSEMBLY BLOCK.....	40
16. FINAL ASSEMBLY BLOCK.....	41
<b>INDEX.....</b>	<b>42</b>

## ATTENTION

1. When placing an order for parts, be sure to list the parts no., model no., and description. There are instances in which if any of this information is omitted, parts cannot be shipped or the wrong parts will be delivered.
2. Please be careful not to make a mistake in the parts no. If the parts no. is in error, a part different from the one ordered may be delivered.
3. Because parts number and parts unit supply in the Preliminary Parts List may be partially changed, please use this parts list for all future reference.

## HOW TO USE THIS PARTS LIST

1. This Parts List shows the parts that are considered necessary for repairs. Other parts, such as resistors and capacitors, are shown in the "Common List for Service Parts". Select and order such parts from the "Common List for Service Parts".
2. The Recommended Spare Parts shows those parts in the Parts List which are considered particularly important for service.
3. Parts not shown in the Parts List and "Common List for Service Parts" will not be supplied in principle.
4. How to read list
  - a) Mechanism Block
  - b) P.C Board Block

### 2. HEAD BASE BLOCK

REF. NO.	PARTS NO.	DESCRIPTION
2-1x	BH-T2023A320A	HEAD BASE BLOCK GX-F66R
2-2	HP-H2206A010A	HEAD R/P PR4-8FU C
2-3	ZS-477876	PAN20x03STL CMT
2-4	ZS-536488	BID20x08STL CMT
2-5	ZG-402895	CS ANGLE ADJUST SPRING

SP (Service Parts) Classification

A small "x" indicates the inability to show that particular part in the Photo or Illustration.

This number corresponds with the individual parts index number in that figure

This number corresponds with the Figure Number

### 6. SYS. CON. P.C BOARD BLOCK

REF. NO.	PARTS NO.	DESCRIPTION
6-1	BA-T2034A070A	PC SYS CON BLK GX-F44R
6-1C1	EI-324536	IC HD14049BP
6-1C2	EI-336801	IC MB8841-564M
6-1C3	EI-331661	IC SN7405N
6-1C4	EI-336725	IC M54527P
6-TR1to4	ET-200985	TR 2SC2603 F,G
6-TR5to28	ET-554657	TR 2SA733A P,Q
6-D1	ED-318292	D SILICON H 1S2473T-77 T26
6-D2to4	ED-308952	D GERMA V 1K34A-LR F07
6-D5to10	ED-318292	D SILICON H 1S2473T-77 T26
6-X1	EI-318384	OSC X'TAL NC-18C

3.579545MHZ

SP (Service Parts) Classification

This reference numbers corresponds with symbol numbers of Schematic Diagrams.

5. Both the kind of part and installation position can be determined by the Parts Number. To determine where a parts number is listed, utilize Parts Index at end of Parts List. It is necessary first of all to find the Parts Number. This can be accomplished by using the Reference Number listed at right of parts number in the Parts Index.

## WARNING

△ INDICATES SAFETY CRITICAL COMPONENTS. FOR CONTINUED SAFETY, REPLACE SAFETY CRITICAL COMPONENTS ONLY WITH MANUFACTURER'S RECOMMENDED PARTS.

## AVERTISSEMENT

△ IL INDIQUE LES COMPOSANTS CRITIQUES DE SÉCURITÉ. POUR MAINTENIR LE DEGRÉ DE SÉCURITÉ DE L'APPAREIL, NE REMPLACER QUE DES PIÈCES RECOMMANDÉES PAR LE FABRICANT

### **X-RAY RADIATION WARNING NOTICE**

#### **WARNING:**

PARTS WHICH INFLUENCE X-RAY RADIATION IN HORIZONTAL DEFLECTION, HIGH VOLTAGE CIRCUITS AND PICTURE TUBE, ETC., ARE INDICATED BY (★) IN THE PARTS LIST. FOR REPLACEMENT PURPOSES, USE ONLY THE TYPE SHOWN IN THE PARTS LIST.

### **PRODUCT SAFETY NOTICE**

#### **WARNING:**

FOR CONTINUED SAFETY, REPLACE SAFETY CRITICAL COMPONENTS ONLY WITH MANUFACTURE'S RECOMMENDED PARTS. THESE PARTS ARE IDENTIFIED BY SHADING AND BY (Δ) ON THE SCHEMATIC DIAGRAM.

### **NOTICE D'AVERTISSEMENT DE RADIATION AUX RAYONS X**

#### **AVERTISSEMENT:**

LES PIÈCES QUI INFLUENCENT LES RAYONS X AU COURS DE LA DÉVIATION HORIZONTALE, LES CIRCUITS À HAUTE TENSION ET LE TUBE-IMAGE, ETC. SONT ACCOMPAGNÉES D'UN ASTÉRISQUE (★) DANS LE CATALOGUE DE PIÈCES DÉTACHÉES. DANS CAS D'UN REMPLACEMENT, UTILISER UNIQUEMENT LES MODÈLES DE PIÈCES INDICQUÉS DANS LE CATALOGUE DE PIÈCES DÉTACHÉES.

### **NOTICE DE SECURITE**

#### **AVERTISSEMENT:**

POUR ÊTRE ASSURÉ D'UNE SECURITE OPTIMALE À TOUT MOMENT, REMPLACER LES COMPOSANTS CRITIQUES UNIQUEMENT PAR LES PIÈCES RECOMMANDÉES PAR LE FABRICANT DE L'APPAREIL. CES PIÈCES SONT IDENTIFIÉES PAR UNE ZONE D'OMBRE ET PAR LE SYMBOLE (Δ) SUR LE SCHEMA DE MONTAGE.

Certain H V failures can increase X-ray radiation. Monitors should not be operated with H V levels exceeding the specified rating for their chassis type. The maximum operating H V specified for the chassis used in these monitor is 7.5 ± 0.5kV at Zero beam current with an input voltage of 120VAC.

Higher voltage may also increase possibility of failure in H V supply.

To determine the presence of high voltage, use an accurate, high impedance, H V meter connected between second anode lead and the C. R. T. dag grounding device. When servicing the High Voltage System, remove static charge from it by connecting a 10k ohm resistor in series with an insulated wire (such as a test probe) between picture tube dag and 2nd anode lead (AC line cord disconnected from AC supply). After servicing fix the anode cap onto picture tube and check and ensure the metal protector is surely adhered.

The picture tube used in this monitor employs integral implosion protection. Replace with tube of the same type number for continued safety.

#### **WARNING**

★ MARK: X-RAY RADIATION RELATED PARTS.

Δ MARK: SAFETY RELATED PARTS.

#### **AVERTISSEMENT**

MARQUE ★: PIÈCES RELATIVES AUX RADIATIONS AUX RAYONS

MARQUE Δ: PIÈCES RELATIVES À LA SECURITE

# I. MODEL AV-U8 EA/EK/S/EO/U/J

## RECOMMENDED SPARE PARTS LIST

Because, if the parts listed below are on hand, almost any repair can be accomplished, we suggest that you stock these Recommended Spare Parts Items.

REF. NO.	PARTS NO.	DESCRIPTION	REF. NO.	PARTS NO.	DESCRIPTION
1	BT-710672	△ TRANS POWER AV-U8EA	64	ES-710663	SW FUNCTION SUL121S
2	BT-710676	△ TRANS POWER AV-U8EO (E), EK, S	65	ES-710648	SW PUSH SPH 121A
3	BT-710671	△ TRANS POWER AV-U8EO (V)	66	ES-710654	SW PUSH SUT11A
4	BT-710675	△ TRANS POWER AV-U8J	67	ES-710650	SW PUSH SUT113
5	BT-710674	△ TRANS POWER AV-U8U (C, A)	68	ES-710655	SW PUSH SUT32A
6	BV-349711	RF MODULATOR MAW2-013 (U)	69	ES-710647	SW PUSH SUV32A 3-THROW
7	BV-345127	RF MODULATOR MFW3-253 (S)	70	ES-710646	SW PUSH SUV42A 4-THROW
8	BV-345125	RF MODULATOR MIW3-253 (EK)	71	ES-337898	SW SLIDE 00120163 01-2 (EA, EK, EO-E, S)
9	BV-349712	RF MODULATOR MNW3-253 (J)	72	ES-710649	SW TACT EVQ-QJ104
10	BV-345129	RF MODULATOR MSW2-633 (EA)	73	ET-307997	TR 2SA1115 D, E
11	BV-349922	RF MODULATOR MSW3-353 (EO)	74	ET-633677	TR 2SA490 O, Y
12	ED-707057	D LED TLG113A GRN	75	ET-511694	TR 2SC1211 D, E
13	ED-707056	D LED TLR113A RED	76	ET-330464	TR 2SC2603 D, E
14	ED-710669	D SILICON H S5295J	77	ET-308141	TR 2SC2603 G
15	ED-604541	D SILICON H 1S2076	78	ET-666404	TR 2SD571 K, L
16	ED-306724	D SILICON S5277B 100/1.0A	79	ET-704058	TR 2SD666A
17	ED-347767	D SILICON V MC911 DOUBLE	80	ET-710667	TR 2SD763
18	ED-347768	D SILICON V MC921 DOUBLE	81	△ CRT 100EB4	
19	ED-322238	D SILICON 1B4B41 100/1.0A	82	EV-316442	R S-FIX H D8 3P 102
20	ED-710863	D SILICON 2B4B41	83	EV-315754	R S-FIX H D8 3P 204
21	ED-319463	D SILICON 4B4B41 100/4.0A	84	EV-319381	R S-FIX H D8 3P 501
22	ED-346615	D ZENER H HZ12 A2	85	EV-315541	R S-FIX H D8 3P 503
23	ED-346542	D ZENER H HZ9L B3	86	EV-710866	VR ROTARY VE12CV 25KB103
24	EF-339902	△ FUSE SEMKO T 250V 0.10A (S, EA, EK, EO)	87	EV-710659	VR SLIDE SA021 A503
25	EF-601964	△ FUSE SEMKO T 250V 1.60A (S, EA, EK, EO)	88	EV-710658	VR SLIDE VJ3013-2PVN 10C-BM 202
26	EF-623125	△ FUSE SEMKO T 250V 2.50A (S, EA, EK, EO)	89	EV-710656	VR SLIDE VJ3013-2GPNV 10C-1Z 104
27	EF-690996	△ FUSE SEMKO T 250V 4.00A (S, EA, EK, EO)	90	EV-710652	VR SLIDE VJ3013-2GPNV 10C-15A 502
28	EF-311839	△ FUSE TSC A 250V 1.60A (J)	91	EV-710657	VR SLIDE VJ3013-2GPNV 10C-15Z 104
29	EF-306951	△ FUSE TSC A 250V 2.50A (J)	92	EV-710653	VR SLIDE VJ3013-2PVN 10C-15A 504
30	EF-306952	△ FUSE TSC A 250V 4.00A (J)			
31	EF-308847	△ FUSE TSC 125V 1.60A (U)			
32	EF-306956	△ FUSE TSC 125V 2.50A (U)			
33	EF-712523	△ FUSE 125V 0.10A (U)			
34	EF-712524	△ FUSE 125V 0.10A (J)			
35	EF-558990	FUSE TSC B 125V 2.50A W/LEAD			
36	EH-337108	FILTER LC LP CL-S-1			
37	EI-338406	IC LM1894N			
38	EI-348785	IC M5220L			
39	EI-337842	IC M5231L			
40	EI-338500	IC STK461			
41	EI-304657	IC TC4011BP			
42	EI-332259	IC TC4052BP			
43	EI-310036	IC TC4066BP			
44	EI-710668	IC UPC1379C			
45	EJ-712019	SOCKET CRT			
46	EJ-301513	SOCKET INLET S-16453 E 2P (EA, EK, EO-E, S)			
47	EJ-710660	TERMINAL SPEAKER YKD21-0007 4P			
48	EJ-710661	TERMINAL SPEAKER YKD21-0146 4P UL			
49	EO-710666	△ COIL DEF CRT YS-33185			
50	EO-338409	△ COIL LF FKOB 160MH02 250μH			
51	EO-710670	COIL CA, TV FLYBACK MSH-D637			
52	EO-710865	COIL CA, TV LINIER TB83-00161			
53	EQ-710665	RELAY POWER FBR-621D012			
54	ER-200972	△ R FUSE ERD2FC S10 1/4W 33R0G			
55	ER-710862	R CT RGC-3 R33J			
56	ER-319455	R FUSE ERD2FC S10 1/4W 10R0C			
57	ER-328520	R FUSE ERD2FC 1/4W 1000G			
58	ER-712036	R FUSE FRM 1/4W 150J			
59	ER-712027	R FUSE FRM 1/2W 101J			
60	ER-328480	R OMF H SNP FS 1W 271J			
61	ER-333015	R OMF H SNP FS 2W 4R7J			
62	ES-710678	△ SW SEESAW SDE1S TV-3 (J, U)			
63	ES-710677	△ SW SEESAW SDE1SE (EA, EK, EO, S)			

## 1. P. C BOARD BLOCK

REF. NO.	PARTS NO.	DESCRIPTION
1-1J	BA-712033	PC VIDEO BLK AV-U8J
1-1U	BA-712035	PC VIDEO BLK AV-U8U
1-1E	BA-710642	PC VIDEO BLK AV-U8EO/EK/EA/S
1-2J	BA-712028	PC POWER & MAIN BLK AV-U8J
1-2U	BA-712029	PC POWER & MAIN BLK AV-U8U
1-2E	BA-710643	PC POWER & MAIN BLK AV-U8EO/EK/EA/S
1-3J	BA-712043	PC AUDIO BLK AV-U8J
1-3U	BA-712044	PC AUDIO BLK AV-U8U
1-3E	BA-710644	PC AUDIO BLK AV-U8EO/EK/EA/S

### NOTES:

- 1) P. C VIDEO BLK including Video PCB, Monitor PCB, and Filter PCB.
- 2) P. C POWER & MAIN BLK including Power & Main PCB, Main VR PCB, Control PCB, and Speaker PCB.
- 3) P. C AUDIO BLK including Audio PCB, Control PCB, and Jack PCB.

## 2. VIDEO P. C BOARD BLOCK

REF. NO.	PARTS NO.	DESCRIPTION
2-IC301	EI-348785	IC M5220L
2-IC302	ET-332259	IC TC4052BP
2-Q301 to 308	ET-330464	TR 2SC2603 D, E
2-Q309 to 316	ET-307997	TR 2SA1115 D, E
2-Q317	ET-330464	TR 2SC2603 D, E
2-Q318	ET-307997	TR 2SA1115 D, E
2-Q319, 320	ET-511694	TR 2SC1211 D, E
2-Q321	ET-307997	TR 2SA1115 D, E
2-Q322, 323	ET-330464	TR 2SC2603 D, E
2-Q324	ET-511694	TR 2SC1211 D, E
2-D301 to 308	ED-347768	D SILICON V MC921 DOUBLE
2-D309, 310	ED-347767	D SILICON V MC911 DOUBLE
2-VR301	EV-316442	R S-FIX H D8 3P 102
2-L301, 302	EO-338420	COIL FIX 2 FL12R202E 202K
2-L303 to 306	EO-336934	COIL FIX 1 LAL03KH 2R2M
2-L307	EO-419624	COIL FIX 1 FL05H 470K
2-R325 to 328	ER-200972	△ R FUSE ERD2FC S10 1/4W 33R0G
2-R358	ER-200972	△ R FUSE ERD2FC S10 1/4W 33R0G
2-R360	ER-200972	△ R FUSE ERD2FC S10 1/4W 33R0G
2-R383	ER-200972	△ R FUSE ERD2FC S10 1/4W 33R0G
2-J3	EJ-712030	PIN J YKB11-0101 1P
2-J3	EJ-712031	PIN J YKB21-5067 3P
2-J3	EJ-712032	PIN J YKC21-0019 6P

## 3. POWER & MAIN P. C BOARD BLOCK

REF. NO.	PARTS NO.	DESCRIPTION
3-IC211	EI-338500	IC STK461
3-IC212	EI-337842	★ IC M5231L
3-Q211	ET-633677	TR 2SA490 O, Y
3-Q212	ET-325502	TR 2SC790 Y
3-Q213	ET-633677	TR 2SA490 O, Y
3-Q214, 215	ET-307997	TR 2SA1115 D, E
3-Q216	ET-330464	TR 2SC2603 D, E
3-D201 to 203	ED-604541	D SILICON H 1S2076
3-D204	ED-319463	D SILICON 4B4B41 100/4.0A
3-D205	ED-710863	D SILICON 2B4B41
3-D206	ED-322238	D SILICON 1B4B41 100/1.0A
3-D207	ED-604541	D SILICON H 1S2076
3-D209, 210	ED-346542	D ZENER H HZ9L B3
3-D211	ED-604541	D SILICON H 1S2076
3-RY201	EQ-710665	RELAY POWER FBR-621D012
3-R269	ER-712027	△ R FUSE FRM 1/2W 101J
3-R278, 279	ER-710862	△ R CT RGC-3 R33J
3-R280, 281	ER-333015	△ R OMF H SNP FS 2W 4R7J
3-R288	ER-328480	△ R OMF H SNP FS 1W 271J
3-R289	ER-315972	★ R CB V CUT RDS 1/4W 223J
3-R290	ER-315982	★ R CB V CUT RDS 1/4W 332J
3-C269, 270	EC-337962	C EC V CUT SM 472M 35.0DC
3-C273	EC-343382	C EC V CUT SM 682M 45.0DC
3-F203J	EF-306951	△ FUSE TSC A 250V 2.50A (J)
3-F203U	EF-306956	△ FUSE TSC 125V 2.50A (U)
3-F203E	EF-623125	△ FUSE SEMKO T 250V 2.50A (EA, EK, EO, S)
3-F204J	EF-306951	△ FUSE TSC A 250V 2.50A (J)
3-F204U	EF-306956	△ FUSE TSC 125V 2.50A (U)
3-F204E	EF-623125	△ FUSE SEMKO T 250V 2.50A (EA, EK, EO, S)
3-F205J	EF-306951	△ FUSE TSC A 250V 2.50A (J)
3-F205U	EF-306957	△ FUSE TSC 125V 4.00A (U)
3-F205E	EF-690996	△ FUSE SEMKO T 250V 4.00A (EA, EK, EO, S)
3-F206J	EF-306952	△ FUSE TSC A 250V 4.00A (J)
3-F206U	EF-306957	△ FUSE TSC 125V 4.00A (U)
3-F206E	EF-306957	△ FUSE TSC 125V 4.00A (EA, EK, EO, S)
3-F207J	EF-311839	△ FUSE TSC A 250V 1.60A (J)
3-F207U	EF-308847	△ FUSE TSC 125V 1.60A (U)
3-F207E	EF-601964	△ FUSE SEMKO T 250V 1.60A (EA, EK, EO, S)
3-F208J	EF-712524	△ FUSE 125V 0.4A (J)
3-F208U	EF-712523	△ FUSE 250V 0.4A (U)
3-F208E	EF-339902	△ FUSE SEMKO T 250V 0.10A (EA, EK, EO, S)
3-F209J	EF-712524	△ FUSE 125V 0.4A (J)
3-F209U	EF-712523	△ FUSE 250V 0.4A (U)
3-F209E	EF-339902	△ FUSE SEMKO T 250V 0.10A (EA, EK, EO, S)

#### 4. AUDIO P. C BOARD BLOCK

REF. NO.	PARTS NO.	DESCRIPTION
4-IC101 to 103	EI-332259	IC TC4052BP
4-IC104	EI-304657	IC TC4011BP
4-Q101 to 104	ET-308141	TR 2SC2603 G
4-Q105 to 109	ET-330464	TR 2SC2603 D, E
4-Q110	ET-307997	TR 2SA1115 D, E
4-Q111	ET-330464	TR 2SC2603 D, E
4-D101 to 107	ED-604541	D SILICON H 1S2076
4-L101 to 108	EO-336934	COIL FIX 1 LAL03KH 2R2M
4-L109, 110	EO-338420	COIL FIX 2 FL12R202E 202K
4-L111 to 116	EO-336934	COIL FIX 1 LAL03KH 2R2M
4-L117, 118	EO-338420	COIL FIX 2 FL12R202E 202K
4-J1	EJ-712040	PIN J YKC21-0008 2P
4-J1	EJ-712041	PIN J YKC21-0018 4P
4-J1	EJ-712042	PIN J YKC21-0019 6P

#### 5. CONTROL P. C BOARD BLOCK

REF. NO.	PARTS NO.	DESCRIPTION
5-Q161	ET-330464	TR 2SC2603 D, E
5-Q162	ET-307997	TR 2SA1115 D, E
5-Q163	ET-330464	TR 2SC2603 D, E
5-Q164 to 167	ET-307997	TR 2SA1115 D, E
5-Q168	ET-330464	TR 2SC2603 D, E
5-D161 to 172	ED-604541	D SILICON H 1S2076
5-D174 to 178	ED-604541	D SILICON H 1S2076
5-D180 to 182	ED-604541	D SILICON H 1S2076
5-D184U	ED-707057	D LED TLG113A GRN (U, J, EA)
5-D184E	ED-707056	D LED TLR113A RED (EK, EO.S)
5-D185	ED-707057	D LED TLG113A GRN
5-D186	ED-707056	D LED TLR113A RED
5-SW161, 162	ES-710646	SW PUSH SUV42A 4-THROW
5-SW163	ES-710647	SW PUSH SUV32A 3-THROW
5-SW164, 165	ES-710648	SW PUSH SPH121A
5-SW166, 167	ES-710649	SW TACT EVQ-QJ104
5-SW168	ES-710650	SW PUSH SUT113
5-VR161	EV-710652	VR SLIDE VJ3013-2GPVN 10C-15A 502
5-VR162	EV-710653	VR SLIDE VJ3013-2PVN 10C-15A 504

#### 6. MONITOR P. C BOARD BLOCK

REF. NO.	PARTS NO.	DESCRIPTION
6-IC401	EI-710668	IC LPC1379C
6-Q401	ET-330464	TR 2SC2603 D, E
6-Q402	ET-704058	TR 2SD666A
6-Q403	ET-330464	TR 2SC2603 D, E
6-Q404	ET-710667	TR 2SD763
6-Q405	ET-511694	TR 2SC1211 D, E
6-D401 to 403	ED-710669	D SILICON H S5295J
6-D404	ED-306724	D SILICON S5277B 100/1.0A
6-D405	ED-604541	D SILICON H 1S2076
6-D406	ED-710669	D SILICON H S5295J
6-D407, 408	ED-604541	D SILICON H 1S2076
6-VR401	EV-316442	R S-FIX H D8 3P 102
6-VR402	EV-315541	R S-FIX H D8 3P 503
6-VR403	EV-710866	VR ROTARY VE12CV 25KB103
6-VR404	EV-319381	R S-FIX H D8 3P 501
6-VR406	EV-315754	R S-FIX H D8 3P 204
6-L401	EO-710865	★ COIL CA, TV LINIER TB83-00161
6-L404	EO-200602	COIL FIX 1 FL05H 561K
6-T401	EO-710670	★ △ COIL CA, TV FLYBACK MSH-D637
6-R452	ER-328520	△ R FUSE ERD2FC 1/4W 1000G
6-R453	ER-319455	△ R FUSE ERD2FC S10 1/4W 10R0G
6-R454	ER-712036	★ △ R FUSE FMR 1/4W 150J
6-C419	EC-318377	C TT V D 1R0M 35DC
6-C425	EC-712037	★ C MMY DTW 562J 100DC
6-C426	EC-712038	★ C MMY DTW 472J 100DC
6-C427	EC-712039	★ C MMY DTW 182J 100DC
6-C431	EC-200947	★ C EC V CUT SM 331 35.0DC

#### 7. MAIN VOLUME P. C BOARD BLOCK

REF. NO.	PARTS NO.	DESCRIPTION
7-IC201	EI-338406	IC LM1894N
7-Q221, 222	ET-307997	TR 2SA1115 D, E
7-Q223	ET-330464	TR 2SC2603 D, E
7-Q224	ET-307997	TR 2SA1115 D, E
7-VR205	EV-710659	VR SLIDE SA021 A503

#### 8. TONE CONTROL P. C BOARD BLOCK

REF. NO.	PARTS NO.	DESCRIPTION
8-IC202	EI-348785	IC M5220L
8-Q201, 202	ET-330464	TR 2SC2603 D, E
8-SW201	ES-710654	SW PUSH SUT11A
8-SW202	ES-710655	SW PUSH SUT32A
8-VR201	EV-710656	VR SLIDE VJ3013-2GPVN 10C-1Z 104
8-VR202, 203	EV-710657	VR SLIDE VJ3013-2GPVN 10C-15Z 104
8-VR204	EV-710658	VR SLIDE VJ3-13-2PVN 10C-BM 202

### 9. SPEAKER P. C BOARD BLOCK

REF. NO.	PARTS NO.	DESCRIPTION
9-L296, 297	EH-337108	FILTER LC LP CL-S-1
9-J296	EJ-710660	TERMINAL SPEAKER YKD 21-0007 4P
9-J296	EJ-710661	TERMINAL SPEAKER YKD21-0146 4P UL
9-F201, 202	EF-558990	FUSE TSC B 125V 2.50A W/LEAD

### 10. FUNCTION P. C BOARD BLOCK

REF. NO.	PARTS NO.	DESCRIPTION
10-R261, 262	ER-341331	R OMF H SNP FS 1W 181J
10-L291, 292	EO-336934	COIL FIX I LAL03KH 2R2M
10-SW291	ES-710663	SW FUNCTION SUL121S
10-J291	EJ-710664	PHONE J YKB21-5060

### 11. JACK P. C BOARD BLOCK

REF. NO.	PARTS NO.	DESCRIPTION
11-Q151, 152	ET-666404	TR 2SD571 K, L
11-J151	EJ-710645	PHONE J YKB21-5066
11-L151, 152	EO-336934	COIL FIX I LAL03KH 2R2M

### 12. HI-FI P. C BOARD BLOCK (JPN ONLY)

REF. NO.	PARTS NO.	DESCRIPTION
12-IC501, 502	EI-310036	IC TC4066BP
12-IC503	EI-304657	IC TC4011BP
12-Q501 to 503ET	330464	TR 2SC2603 D, E
12-D501	ED-346615	D ZENER H HZ12 A2

### 13. FILTER P.C BOARD BLOCK

REF. NO.	PARTS NO.	DESCRIPTION
13-C601J	EC-338419	△ C MMY V ECQUE 473JM 125AC (J, U)
13-C601V	EC-331410	△ C MMY V ECQUF 473M 250AC (EO-V)
13-R601	ER-712583	△ R SD 1/2W 275M (U)
13-F601	EF-308847	△ FUSE TSC 125V 1.60A (U)
13-L601	EO-338409	△ COIL LF FKOB160MH02 250μH (EO-V)



**POWER RF BLOCK**

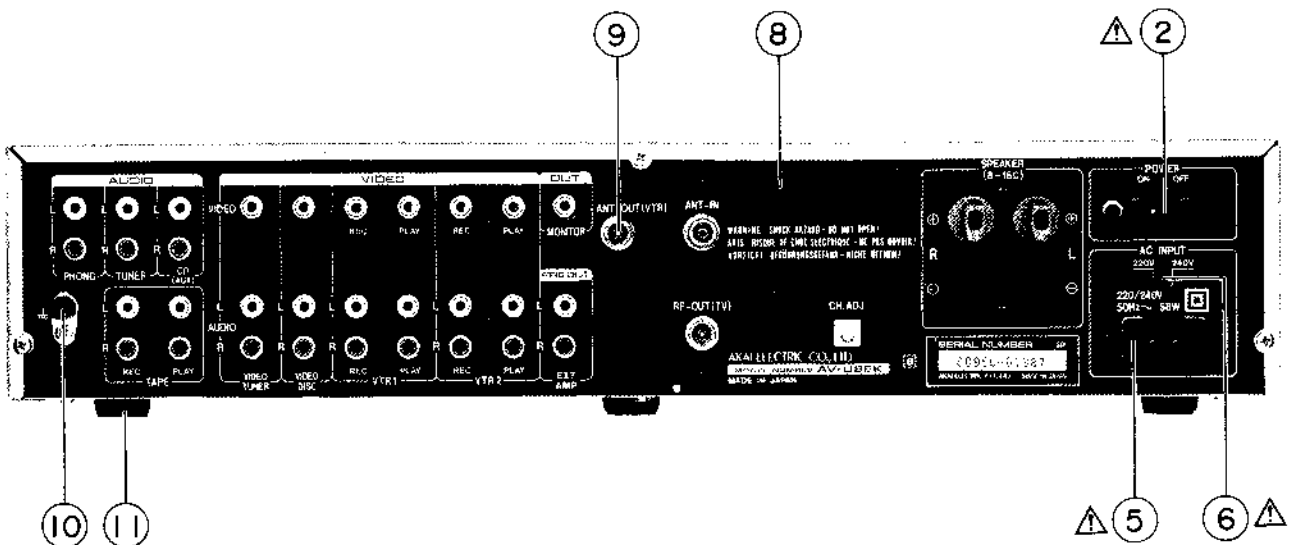
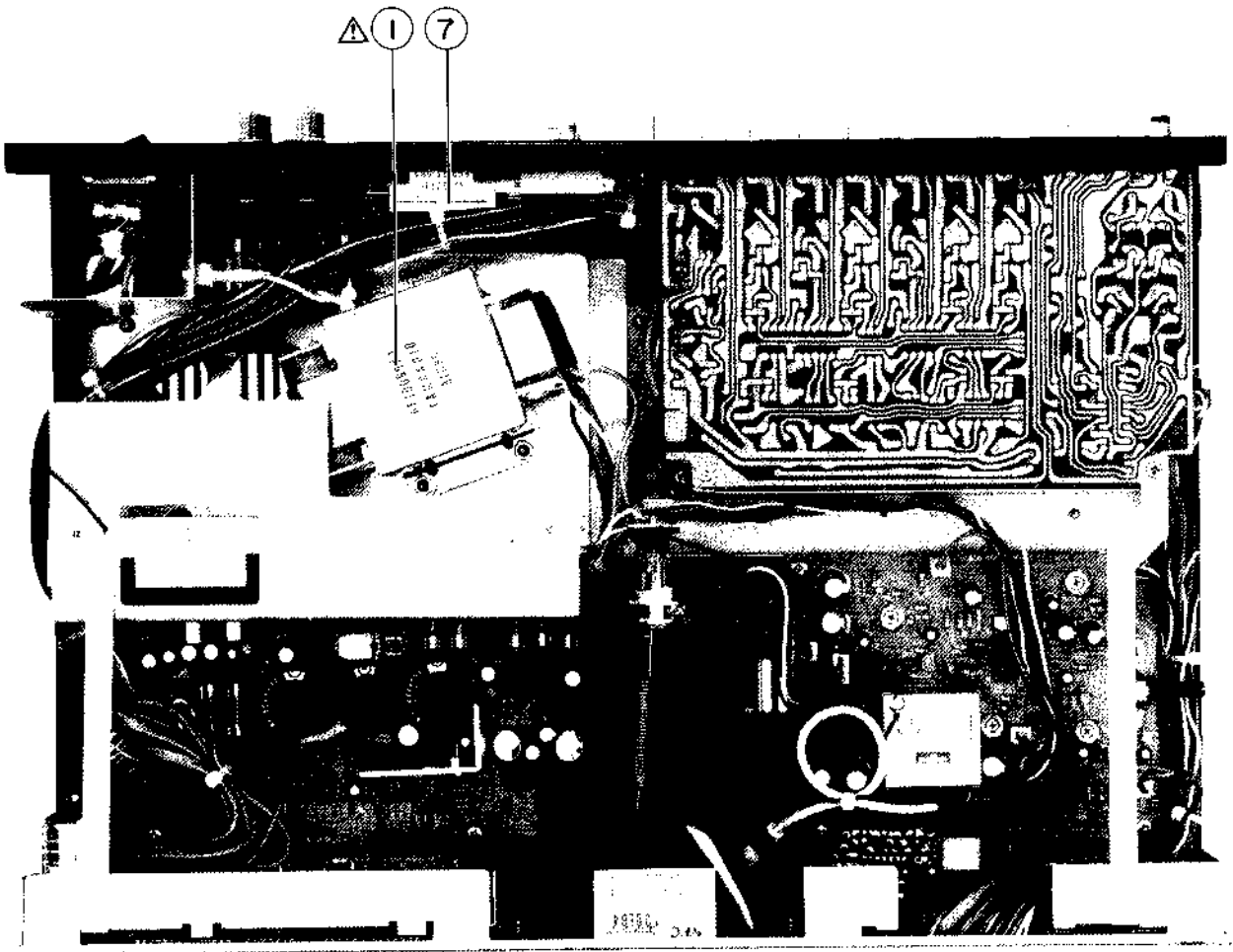

## 14. POWER & RF BLOCK

REF. NO.	PARTS NO.	DESCRIPTION
14-1J	BT-710675	△ TRANS POWER AV-U8J
14-1U	BT-710674	△ TRANS POWER AV-U8U (C, A)
14-1EK	BT-710676	△ TRANS POWER AV-U8EO (E), EK, S
14-1EA	BT-710672	△ TRANS POWER AV-U8EA
14-1EV	BT-710671	△ TRANS POWER AV-U8EO (V)
14-2J	ES-710678	△ SW SEESAW SDE1S TV-3 (J, U)
14-2E	ES-710677	△ SW SEESAW SDE1SE (EA, EK, EO, S)
14-3	EC-331410	△ C MMY V ECQUF 473M 250AC (EA, EK, EO-S) (C601)
14-4	ER-712584	△ R SD 1/4W 335J (EO-E) (R602)
14-5	EJ-301513	△ SOCKET INLET S-16453 E 2P (EA, EK, EO-E, S)
14-6	ES-337898	△ SW SLIDE 00120163 01-2 (EA, EK, EO-E, S)
14-7U	BV-349711	RF MODULATOR MAW2-013 (U)
14-7EA	BV-345129	RF MODULATOR MSW2-633 (EA)
14-7EK	BV-345125	RF MODULATOR MIW3-253 (EK)
14-7EO	BV-349922	RF MODULATOR MSW3-353 (EO)
14-7S	BV-345127	RF MODULATOR MFW3-253 (S)
14-7J	BV-349712	RF MODULATOR MNW3-253 (J)
14-8J	BD-710855	PANEL REAR AV-U8J
14-8UC	SP-710857	PANEL REAR AV-U8U (C)
14-8UA	BD-710856	PANEL REAR AV-U8U (A)
14-8S	BD-712007	PANEL REAR AV-U8S
14-8EA	BD-712006	PANEL REAR AV-U8EA
14-8EK	BD-710860	PANEL REAR AV-U8EK
14-8EV	BD-710858	PANEL REAR AV-U8EO (V)
14-8EO	BD-710859	PANEL REAR AV-U8EO (E)
14-9J	EJ-712024	CONNECTOR F YKV11-0002 (J,U)
14-9S	EJ-712025	CONNECTOR A YKV11-0164 (S)
14-9E	EJ-712022	CONNECTOR A YKV11-0096 (EA, EK, EO)
14-10	EJ-329610	TERMINAL W/SCREW UB-0067L 1P
14-11	SA-332850	ROUND FOOT

# ASSEMBLY BLOCK

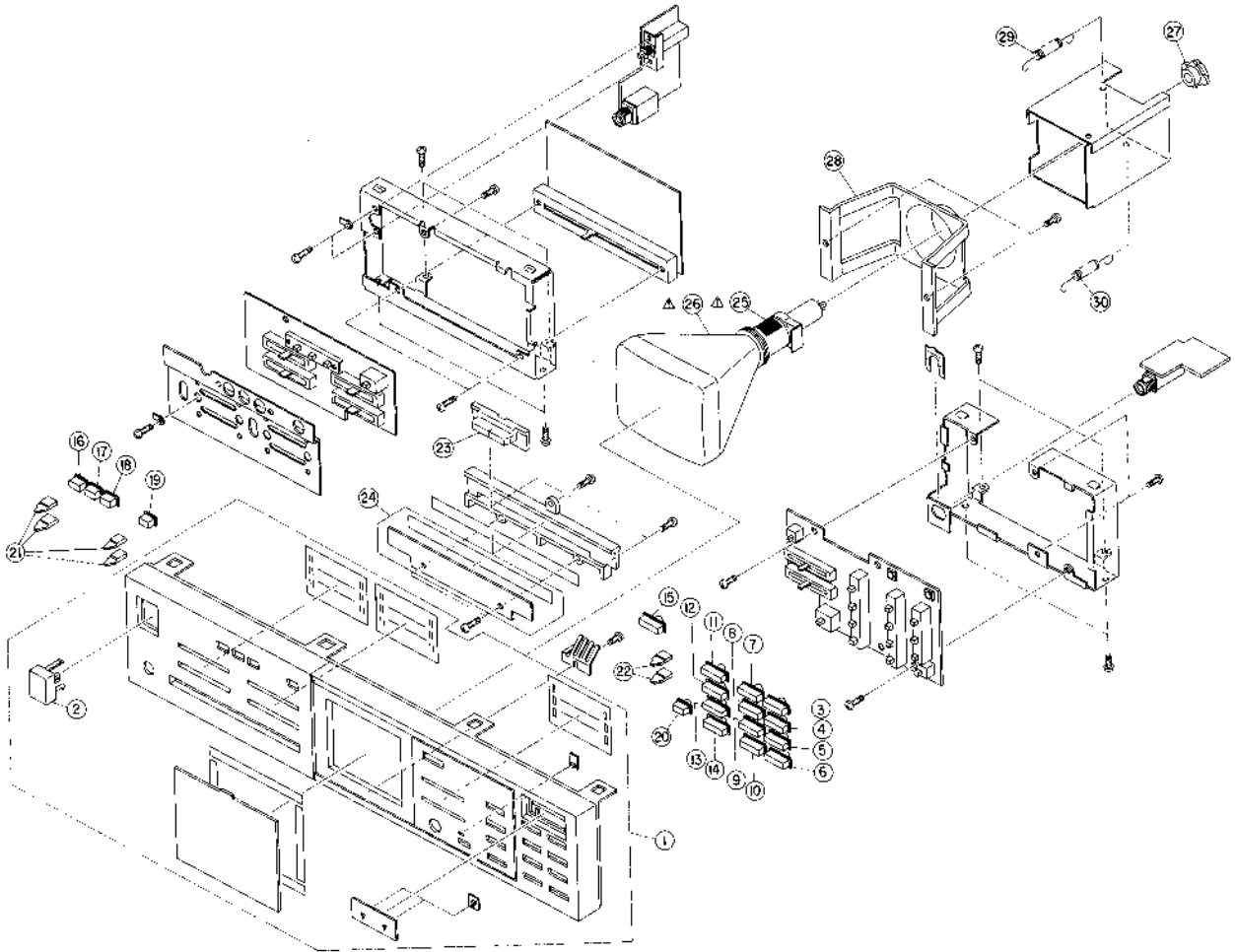

## 15. ASSEMBLY BLOCK

REF. NO.	PARTS NO.	DESCRIPTION	REF. NO.	PARTS NO.	DESCRIPTION
15-1J	BD-710680	PANEL FRONT BLK AV-U8J	15-16	SK-710699	KNOB B L (CH1)
15-1U	BD-710681	PANEL FRONT BLK AV-U8U	15-17	SK-710847	KNOB B ST
15-1E	BD-710683	PANEL FRONT BLK AV-U8EO/EK/S	15-18	SK-710848	KNOB B R (CH2)
15-1EA	BD-710682	PANEL FRONT BLK AV-U8EA	15-19	SK-710849	KNOB B DNR
15-2	SK-710852	KNOB FUNCTION	15-20J	SK-712008	KNOB B (J)
15-3	SK-710685	KNOB A PHONO	15-20U	SK-710851	KNOB B RF OUT (U, EA)
15-4	SK-710686	KNOB A TUNER	15-20E	SK-710850	KNOB B INT/MONI (EK, EO, S)
15-5	ES-710677	SW SEESAW SDEISE	15-21	SK-343009	KNOB OUTPUT
15-6	SK-710688	KNOB A TAPE	15-21P	SK-343009B	KNOB OUTPUT-P (EO-P)
15-7	SK-710689	KNOB A TUNER 1	15-22	SK-343009E	KNOB OUTPUT-P2
15-8	SK-710690	KNOB A V. DISC	15-23	SP-712585	PANEL VOLUME
15-9	SK-710691	KNOB A VTR 1	15-24	SK-712586	KNOB VOLUME
15-10	SK-710692	KNOB A VTR 2	15-25	EO-710666	★ Δ COIL DEF CRT YS-33185
15-11	SK-710693	KNOB A TUNER 1	15-26	EU-710861	Δ CRT 100EB4
15-12	SK-710694	KNOB A V. DISC	15-27	EJ-712019	SOCKET CRT
15-13	SK-710696	KNOB A VTR 1-2	15-28	MZ-712026	HOLDER CRT
15-14	SK-710697	KNOB A VTR 2-1	15-29	ZG-712020	SP
15-15	SK-710698	KNOB A MONITOR	15-30	ZG-712021	SP

## FINAL ASSEMBLY BLOCK

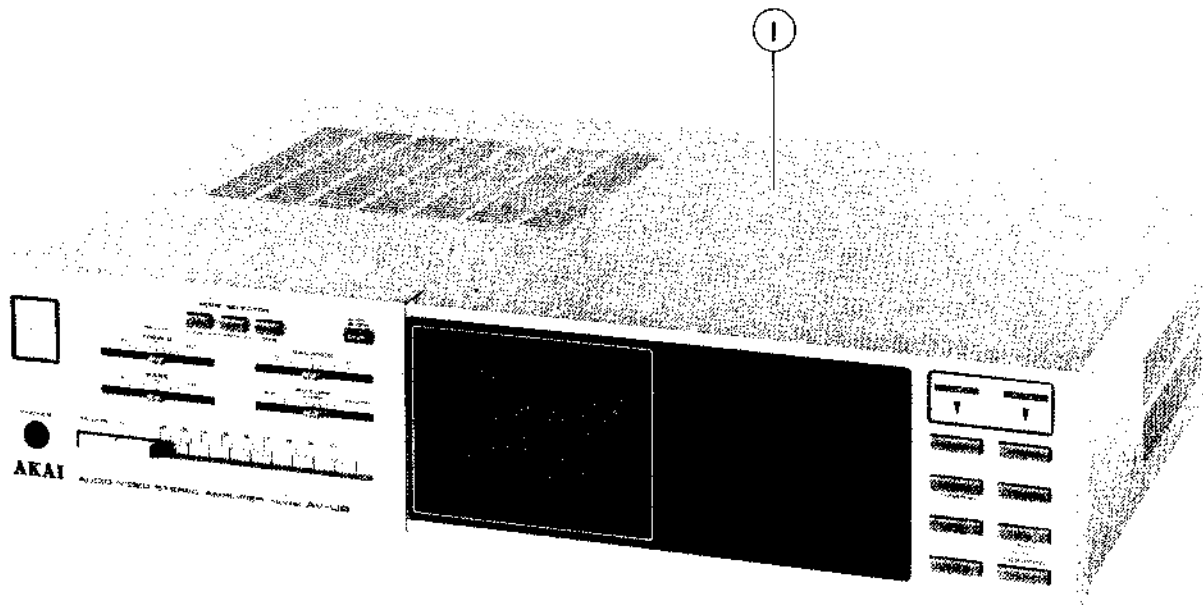

### 16. FINAL ASSEMBLY BLOCK

REF. NO.	PARTS NO.	DESCRIPTION
16-1	SP-710854	COVER
16-2U	EW-343363	△ AC CORD 2 CORES KP-8, SPT-2 105C UC (U)
16-2J	EW-306427	△ AC CORD 2 CORES KP-211, VFF J (J)
16-2EA	EW-322401	△ AC CORD 2 CORES KP-560/KS-15 S (EA)
16-2EK	EW-322400	△ AC CORD 2 CORES KS-15/GTB S-2F B (EK)
16-2S	EW-315767	△ AC CORD 2 CORES KP-419C/ KS-15 EV (EO-E, S)
16-2V	EW-336923	△ AC CORE 2 CORES KP-419C, LTCE-2F EV (EO-V)
16-3	AX-350757	CORD RR-AV100 PIN-PIN (EA, EK, EO)
16-4	AV-349714	CORD S-L4700 #015 VY-21 (U)
16-5	AV-321758	CORD VY-15 ANTENNA CABLE (EA, EK, EO)
16-6	AV-348415	CORD SECAM (S)
16-7	AX-350757	CORD RR-AV100 PIN-PIN (J, U)
16-8	AV-349715	CORD VY-22 ANTENNA CABLE (J)
16-9	AV-349713	MATCHING TRANS ZT-3 S-U5025 (J)

# INDEX

## AV-U8

PARTS NO.	REF. NO.	PARTS NO.	REF. NO.	PARTS NO.	REF. NO.	PARTS NO.	REF. NO.
AV-321758	16-5	ED-604541	5-D165	EJ-712031	2-J3	ET-307997	2-Q314
AV-348415	16-6	ED-604541	5-D163	EJ-712032	2-J3	ET-307997	2-Q318
AV-349713	16-9	ED-604541	5-D161	EJ-712040	4-J1	ET-307997	2-Q321
AV-349714	16-4	ED-604541	5-D162	EJ-712041	4-J1	ET-307997	2-Q313
AV-349715	16-8	ED-604541	5-D172	EJ-712042	4-J1	ET-307997	2-Q311
AX-350757	16-7	ED-604541	5-D171	EO-200602	6-L404	ET-307997	2-Q316
AX-350757	16-3	ED-604541	5-D167	EO-336934	2-L303	ET-307997	2-Q315
BA-710642	1-E	ED-604541	5-D181	EO-336934	2-L304	ET-307997	3-Q214
BA-710643	1-2E	ED-604541	5-D170	EO-336934	2-L305	ET-307997	3-Q215
BA-710644	1-3E	ED-604541	5-D178	EO-336934	2-L306	ET-307997	4-Q110
BA-712028	1-2J	ED-604541	5-D174	EO-336934	4-L101	ET-307997	5-Q166
BA-712029	1-2U	ED-604541	5-D177	EO-336934	4-L102	ET-307997	5-Q165
BA-712033	1-1J	ED-604541	5-D169	EO-336934	4-L105	ET-307997	5-Q164
BA-712035	1-1U	ED-604541	5-D176	EO-336934	4-L111	ET-307997	5-Q162
BA-712043	1-3J	ED-604541	5-D175	EO-336934	4-L115	ET-307997	5-Q167
BA-712044	1-3U	ED-604541	5-D180	EO-336934	4-L108	ET-307997	7-Q224
BD-710680	15-1J	ED-604541	5-D182	EO-336934	4-L104	ET-307997	7-Q222
BD-710681	15-1U	ED-604541	6-D408	EO-336934	4-L103	ET-307997	7-Q221
BD-710682	15-1EA	ED-604541	6-D407	EO-336934	4-L106	ET-308141	4-Q101
BD-710683	15-1E	ED-604541	6-D405	EO-336934	4-L107	ET-308141	4-Q102
BD-710855	14-8J	ED-707056	5-D184	EO-336934	4-L112	ET-308141	4-Q104
BD-710856	14-8UA	ED-707056	5-D186	EO-336934	4-L116	ET-308141	4-Q103
BD-710858	14-8EV	ED-707057	5-D185	EO-336934	4-L114	ET-325502	3-Q212
BD-710859	14-8EO	ED-707057	5-D184	EO-336934	4-L113	ET-330464	2-Q317
BD-710860	14-8EK	ED-710669	6-D401	EO-336934	10-L292	ET-330464	2-Q302
BD-712006	14-8EA	ED-710669	6-D402	EO-336934	10-L291	ET-330464	2-Q306
BD-712007	14-8S	ED-710669	6-D403	EO-336934	11-L151	ET-330464	2-Q304
BT-710671	14-1EV	ED-710669	6-D406	EO-336934	11-L152	ET-330464	2-Q305
BT-710672	14-1EA	ED-710863	3-D205	EO-338409	13-L601	ET-330464	2-Q307
BT-710674	14-1U	ED-306951	3-F203	EO-338420	2-L302	ET-330464	2-Q303
BT-710675	14-1J	EF-306951	3-F204	EO-338420	2-L301	ET-330464	2-Q322
BT-710676	14-1EK	EF-306951	3-F205	EO-338420	4-L109	ET-330464	2-Q308
BV-345125	14-7EK	EF-306952	3-F206	EO-338420	4-L118	ET-330464	2-Q323
BV-345127	14-7S	EF-306956	3-F203	EO-338420	4-L110	ET-330464	2-Q301
BV-345129	14-7EA	EF-306956	3-F204	EO-338420	4-L117	ET-330464	3-Q216
BV-349711	14-7U	EF-306957	3-F206	EO-419624	2-L307	ET-330464	4-Q109
BV-349712	14-7J	EF-306957	3-F206	EO-710666	15-25	ET-330464	4-Q105
BV-349922	14-7EO	EF-306957	3-F205	EO-710670	6-T401	ET-330464	4-Q108
EC-200947	6-C431	EF-308847	3-F207	EO-710865	6-L401	ET-330464	4-Q111
EC-318377	6-C419	EF-308847	13-F601	EQ-710665	3-RY201	ET-330464	4-Q106
EC-331410	13-C601V	EF-311839	3-F207	ER-200972	2-R383	ET-330464	4-Q107
EC-331410	14-3	EF-339902	3-F208	ER-200972	2-R325	ET-330464	5-Q161
EC-337962	3-C269	EF-339902	3-F209	ER-200972	2-R358	ET-330464	5-Q163
EC-337962	3-C270	EF-558990	9-F202	ER-200972	2-R326	ET-330464	5-Q168
EC-338419	13-C601J	EF-558990	9-F201	ER-200972	2-R328	ET-330464	6-Q403
EC-343382	3-C273	EF-601964	3-F207	ER-200972	2-R360	ET-330464	6-Q401
EC-712037	6-C425	EF-623125	3-F204	ER-200972	2-R327	ET-330464	7-Q223
EC-712038	6-C426	EF-623125	3-F203	ER-315972	3-R289	ET-330464	8-Q202
EC-712039	6-C427	EF-690996	3-F205	ER-315982	3-R290	ET-330464	8-Q201
ED-306724	6-D404	EF-712523	3-F208	ER-319455	6-R453	ET-330464	12-Q503
ED-319463	3-D204	EF-712523	3-F209	ER-328480	3-R288	ET-330464	12-Q502
ED-322238	3-D206	EF-712524	3-F208	ER-328520	6-R452	ET-330464	12-Q501
ED-346542	3-D209	EF-712524	3-F209	ER-333015	3-R281	ET-511694	2-Q324
ED-346542	3-D210	EH-337108	9-L296	ER-333015	3-R280	ET-511694	2-Q319
ED-346615	12-D501	EH-337108	9-L297	ER-341331	10-R261	ET-511694	2-Q320
ED-347767	2-D309	EI-304657	4-IC104	ER-341331	10-R262	ET-511694	6-Q405
ED-347767	2-D310	EI-304657	12-IC503	ER-710862	3-R279	ET-633677	3-Q211
ED-347768	2-D301	EI-310036	12-IC502	ER-710862	3-R278	ET-633677	3-Q213
ED-347768	2-D302	EI-310036	12-IC501	ER-712027	3-R269	ET-666404	11-Q152
ED-347768	2-D303	EI-332259	2-IC302	ER-712036	6-R454	ET-666404	11-Q151
ED-347768	2-D304	EI-332259	4-IC103	ER-712583	13-R601	ET-704058	6-Q402
ED-347768	2-D305	EI-332259	4-IC102	ER-712584	14-4	ET-710667	6-Q404
ED-347768	2-D306	EI-332259	4-IC101	ES-337898	14-6	EU-710861	15-26
ED-347768	2-D308	EI-337842	3-IC212	ES-710646	5-SW161	EV-315541	6-VR402
ED-347768	2-D307	EI-338406	7-JC201	ES-710646	5-SW162	EV-315754	6-VR406
ED-604541	3-D201	EI-338500	3-IC211	ES-710647	5-SW163	EV-316442	2-VR301
ED-604541	3-D202	EI-348785	2-IC301	ES-710648	5-SW165	EV-316442	6-VR401
ED-604541	3-D203	EI-348785	8-IC202	ES-710648	5-SW164	EV-319381	6-VR404
ED-604541	3-D211	EI-710668	6-IC401	ES-710649	5-SW167	EV-710652	5-VR161
ED-604541	3-D207	EJ-301513	14-5	ES-710649	5-SW166	EV-710653	5-VR162
ED-604541	4-D104	EJ-329610	14-10	ES-710650	5-SW168	EV-710656	8-VR201
ED-604541	4-D102	EJ-710645	11-J151	ES-710654	8-SW201	EV-710657	8-VR202
ED-604541	4-D101	EJ-710660	9-J296	ES-710655	8-SW202	EV-710657	8-VR203
ED-604541	4-D103	EJ-710661	9-J296	ES-710663	10-SW291	EV-710658	8-VR204
ED-604541	4-D107	EJ-710664	10-J291	ES-710677	14-2E	EV-710659	7-VR205
ED-604541	4-D105	EJ-712019	15-27	ES-710677	15-27	EV-710866	6-VR403
ED-604541	4-D106	EJ-712022	14-9E	ES-710678	14-2J	EW-306427	16-2J
ED-604541	5-D168	EJ-712024	14-9J	ET-307997	2-Q309	EW-315767	16-2S
ED-604541	5-D166	EJ-712025	14-9S	ET-307997	2-Q310	EW-322400	16-2EK
ED-604541	5-D164	EJ-712030	2-J3	ET-307997	2-Q312	EW-322401	16-2EA

# INDEX

PARTS NO.	REF. NO.	PARTS NO.	REF. NO.	PARTS NO.	REF. NO.	PARTS NO.	REF. NO.
EW-336923	16-2V	SK-710689	15-7	SK-710847	15-17	SP-712585	15-23
EW-343363	16-2U	SK-710690	15-8	SK-710848	15-18	ZG-712020	15-29
MZ-712026	15-28	SK-710691	15-9	SK-710849	15-19	ZG-712021	15-30
SA-332850	14-11	SK-710692	15-10	SK-710850	15-20E		
SK-343009	15-21	SK-710693	15-11	SK-710851	15-20U		
SK-343009B	15-21P	SK-710694	15-12	SK-710852	15-2		
SK-343009E	15-22	SK-710696	15-13	SK-712008	15-20J		
SK-710685	15-3	SK-710697	15-14	SK-712586	15-24		
SK-710686	15-4	SK-710698	15-15	SP-710854	16-1		
SK-710688	15-6	SK-710699	15-16	SP-710857	14-8UC		

# AKAI

MODEL **AV-U8** EA/EK/S/EO/U/J

SECTION 3

## SCHEMATIC DIAGRAM

TABLE OF CONTENTS

1. SCHEMATIC DIAGRAM OF ICs.....	45
2. OVERALL BLOCK DIAGRAM.....	46
3. CONNECTION DIAGRAM.....	47
4. AUDIO SCHEMATIC DIAGRAM.....	48
5. VIDEO/MONITOR SCHEMATIC DIAGRAM.....	49
6. RF MODULATOR (EK, EO) SCHEMATIC DIAGRAM.....	50
7. RF MODULATOR (EA, S) SCHEMATIC DIAGRAM.....	51
8. RF MODULATOR (U, J) SCHEMATIC DIAGRAM.....	52

STK461

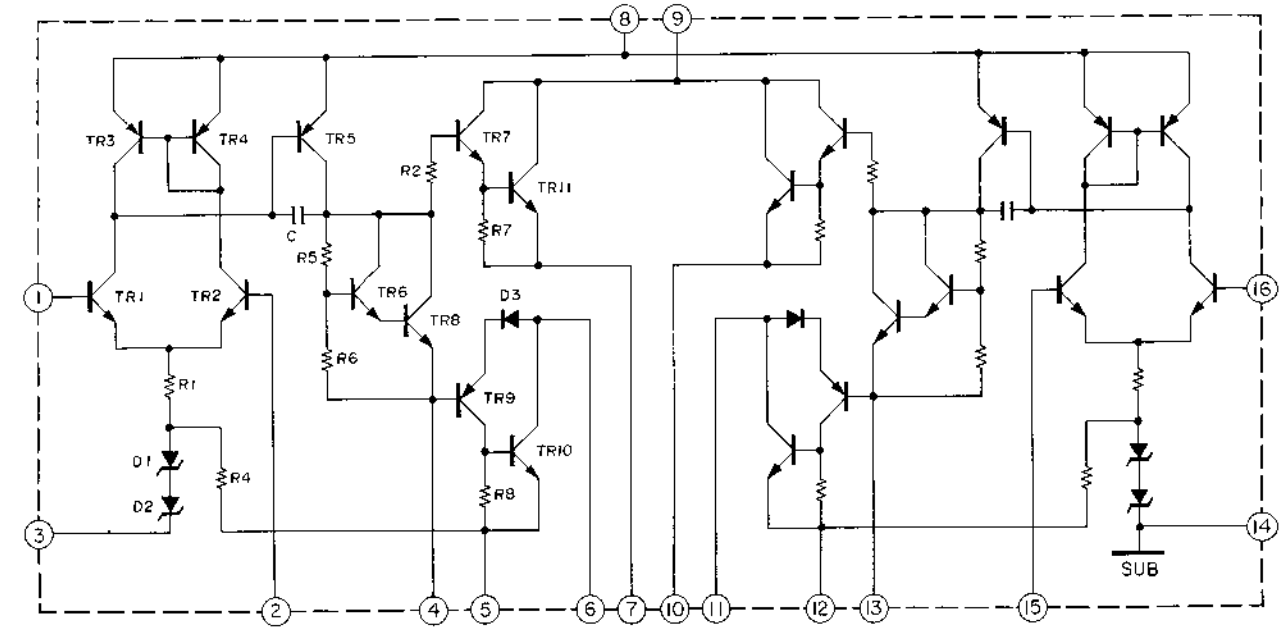

TC4011BP

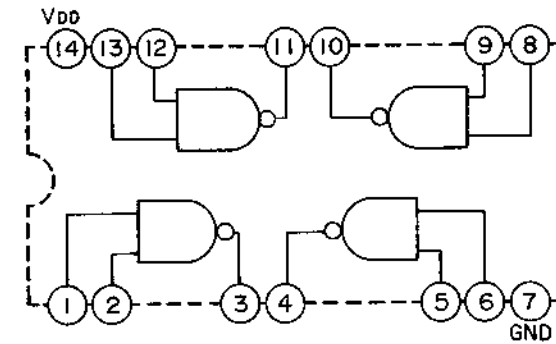

M5231L

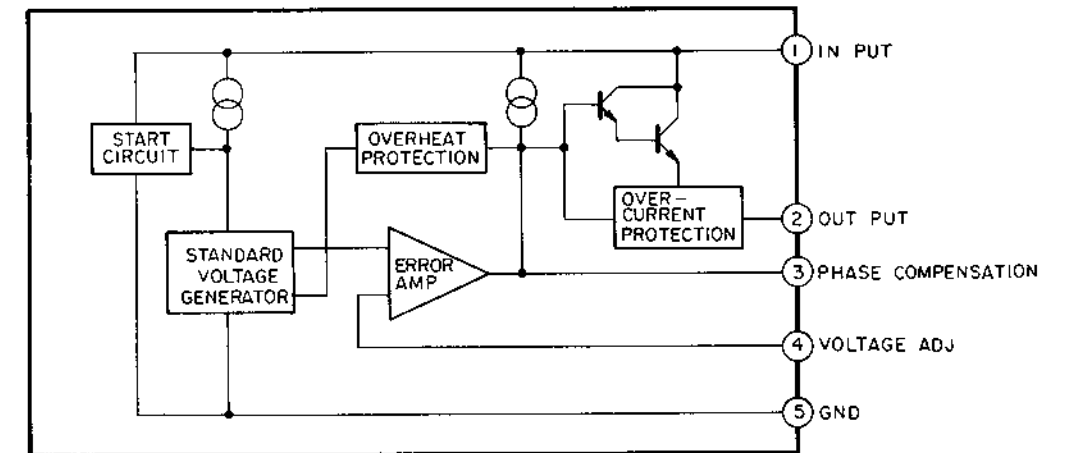

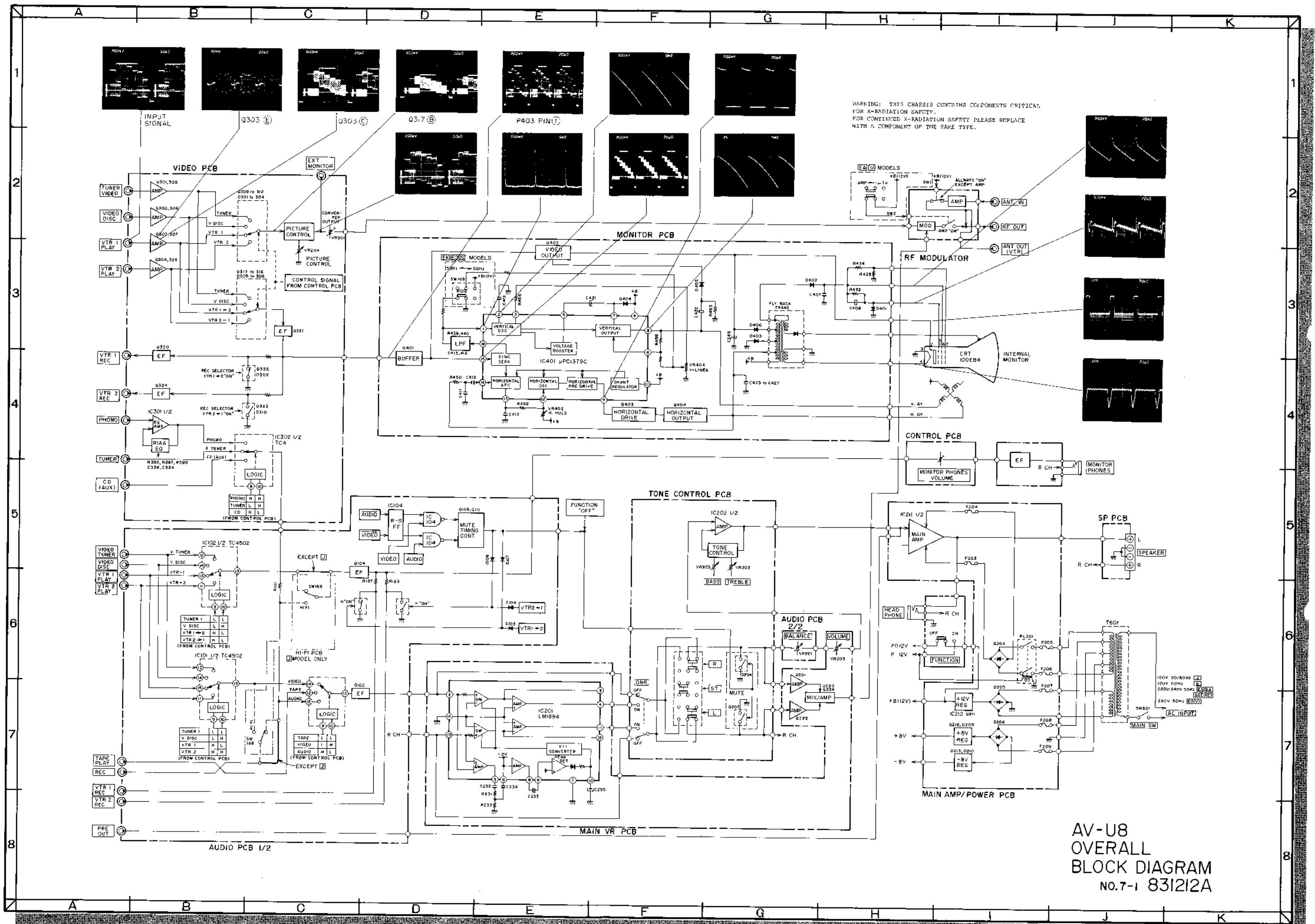



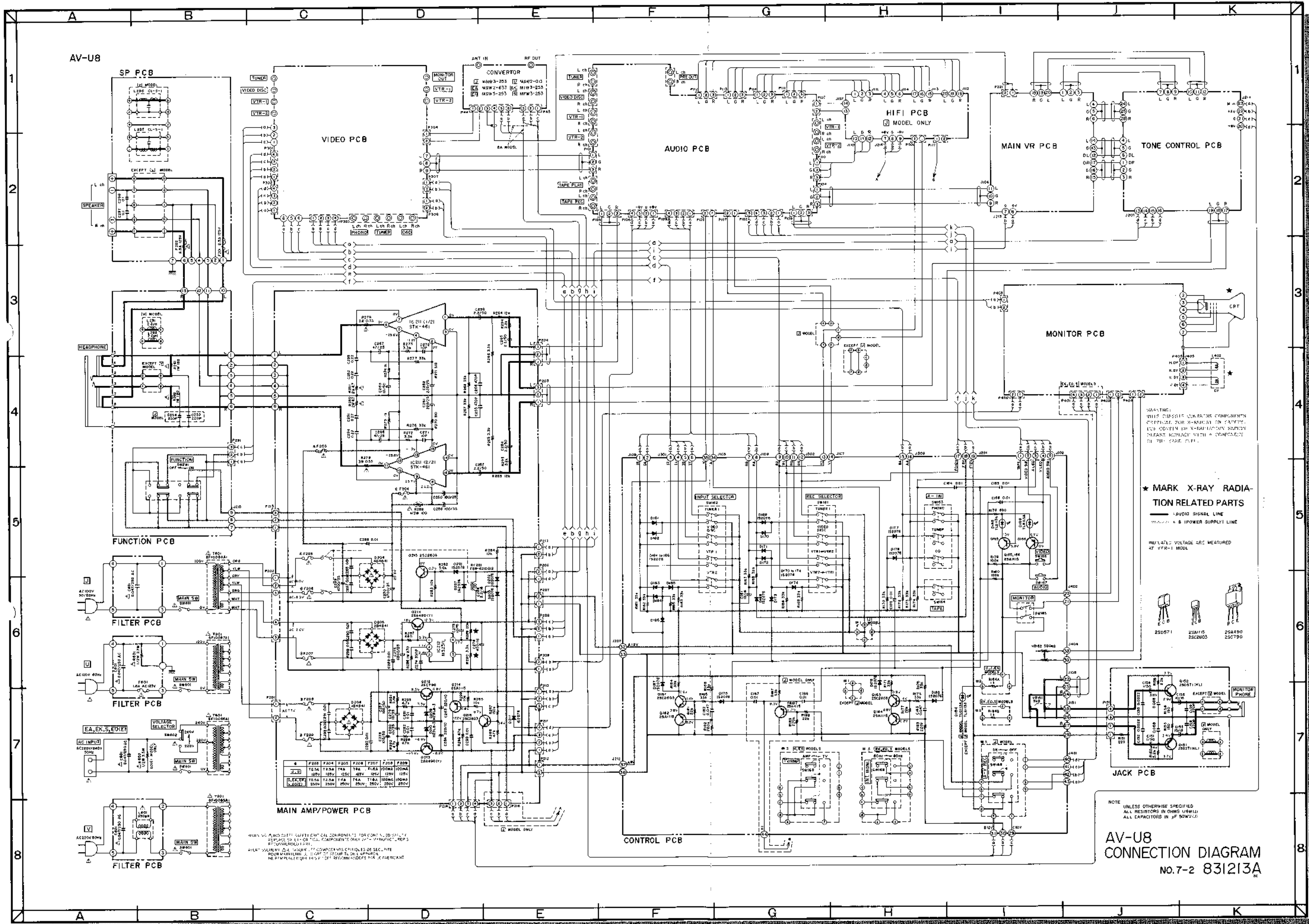

WARNING: THIS CIRCUIT CONTAINS COMPONENTS CRITICAL TO THE SAFETY OF THE USER. IF YOU ARE NOT A QUALIFIED ELECTRICIAN, DO NOT ATTEMPT TO REPAIR OR REPLACE ANY OF THE CRITICAL COMPONENTS UNLESS YOU ARE A QUALIFIED ELECTRICIAN.

★ MARK X-RAY RADIATION RELATED PARTS

— AUDIO SIGNAL LINE  
 — POWER SUPPLY LINE

INDICATED VOLTAGE ARE MEASURED AT VTR-1 MODEL



**AV-U8 CONNECTION DIAGRAM**  
 No.7-2 831213A

AV-U8

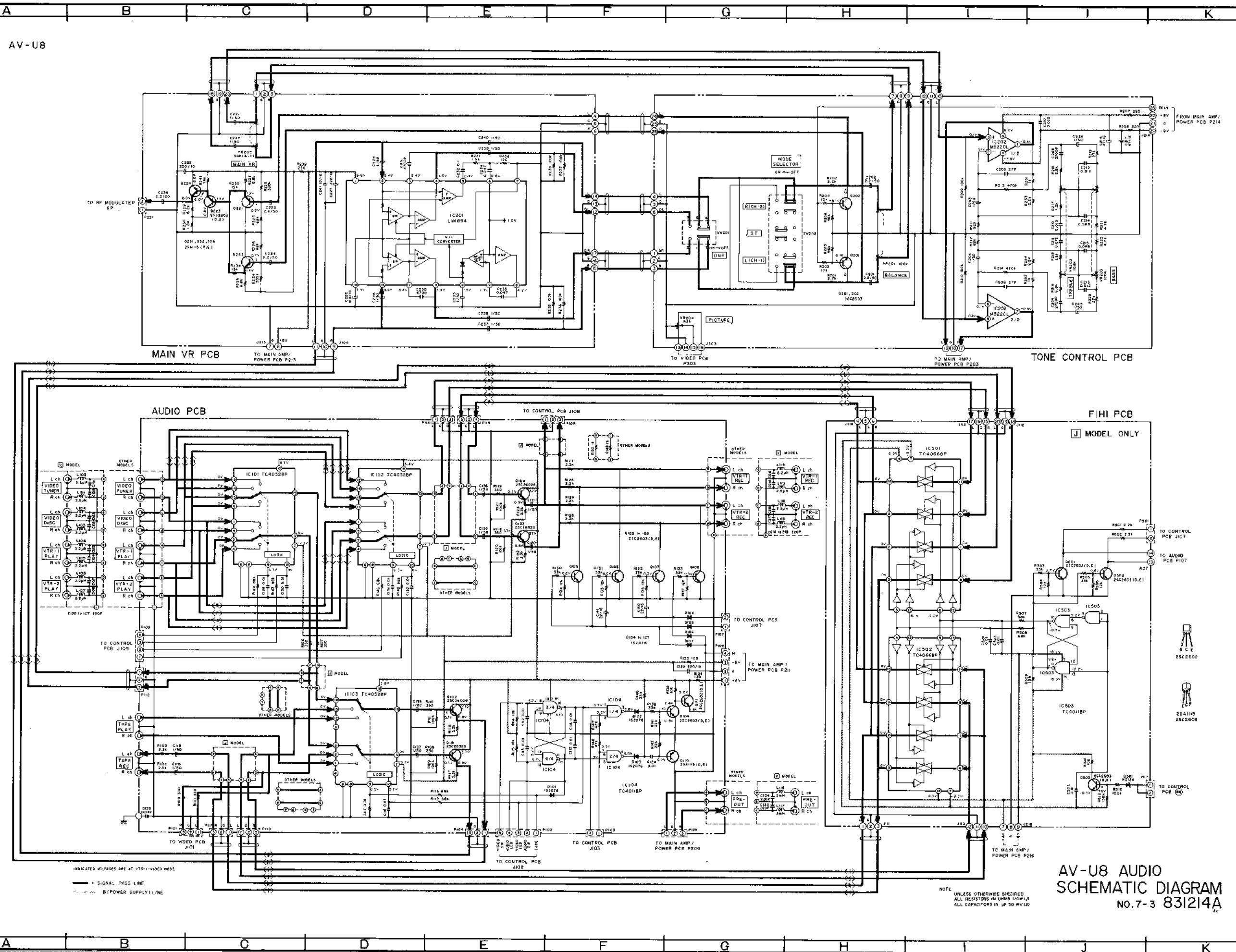

AV-U8 AUDIO SCHEMATIC DIAGRAM NO. 7-3 831214A

NOTE: UNLESS OTHERWISE SPECIFIED, ALL RESISTORS IN OHMS (1/4W, 1/2W). ALL CAPACITORS IN μF (50 WV).



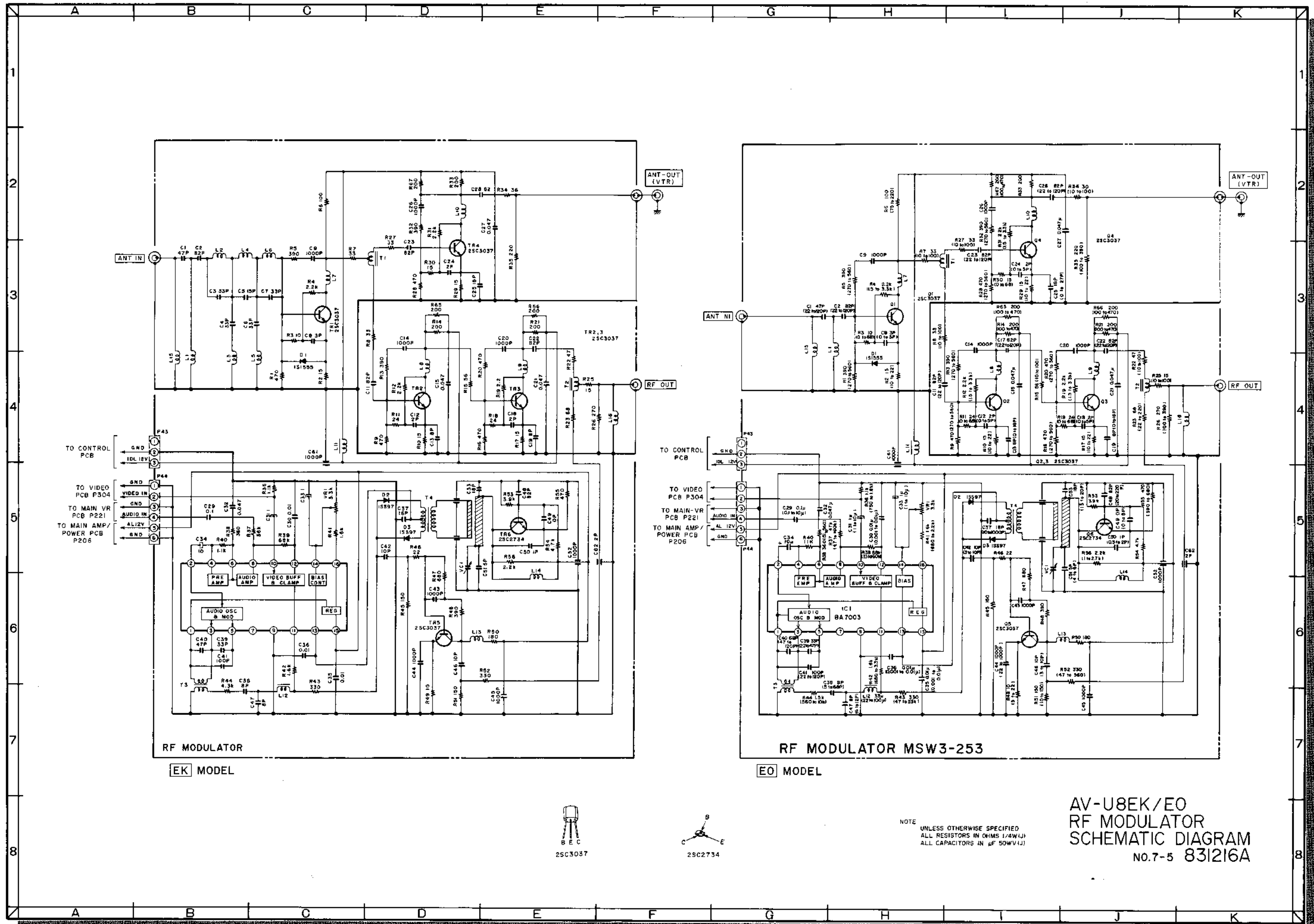

RF MODULATOR  
[EK] MODEL

RF MODULATOR MSW3-253  
[EO] MODEL

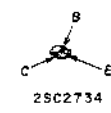
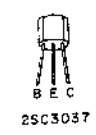

NOTE  
UNLESS OTHERWISE SPECIFIED,  
ALL RESISTORS IN OHMS (1/4W/1%)  
ALL CAPACITORS IN  $\mu$ F (50WV/1%)

AV-U8EK/E0  
RF MODULATOR  
SCHEMATIC DIAGRAM  
NO.7-5 831216A

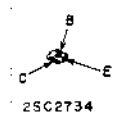
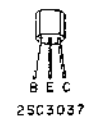
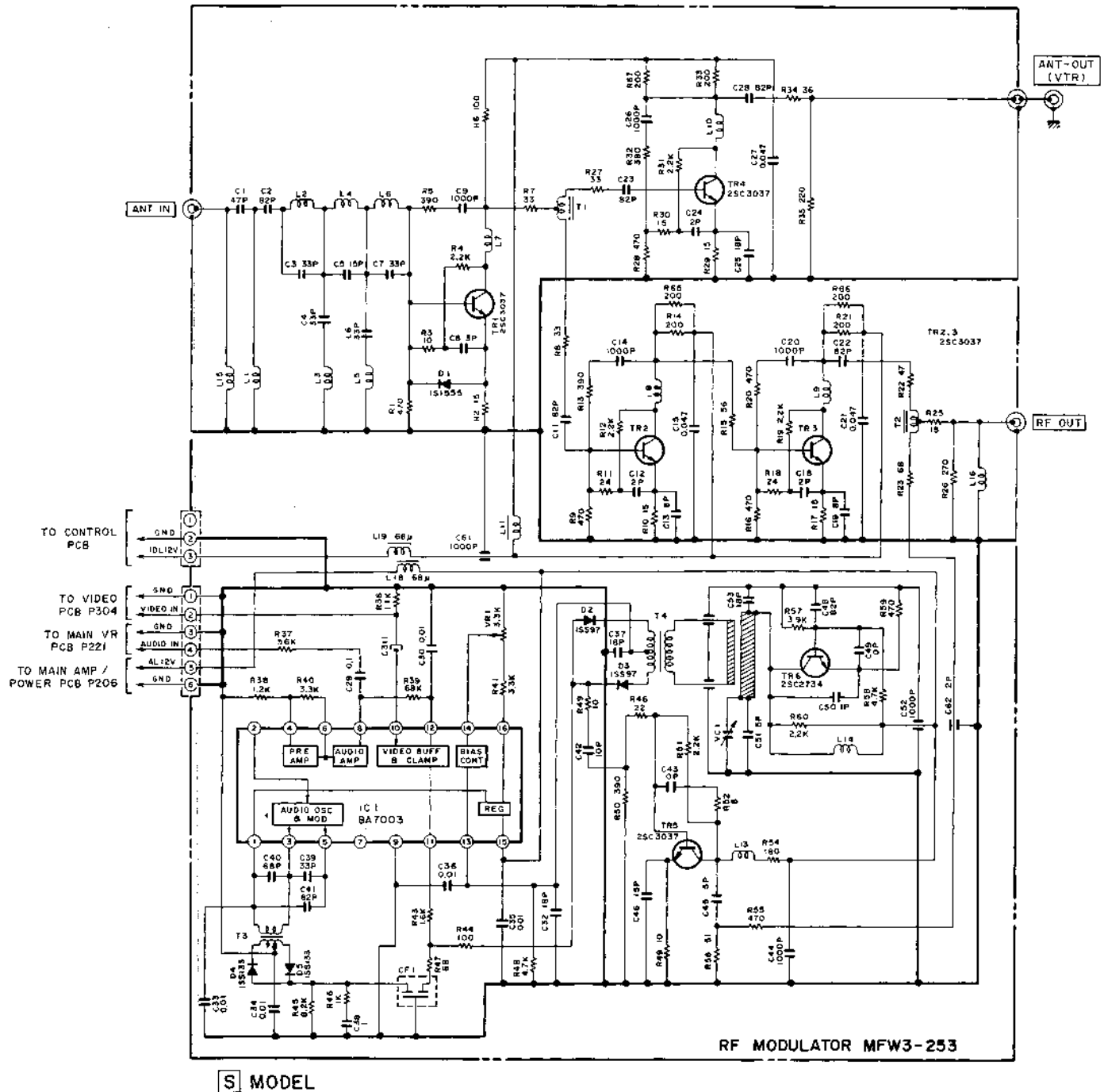
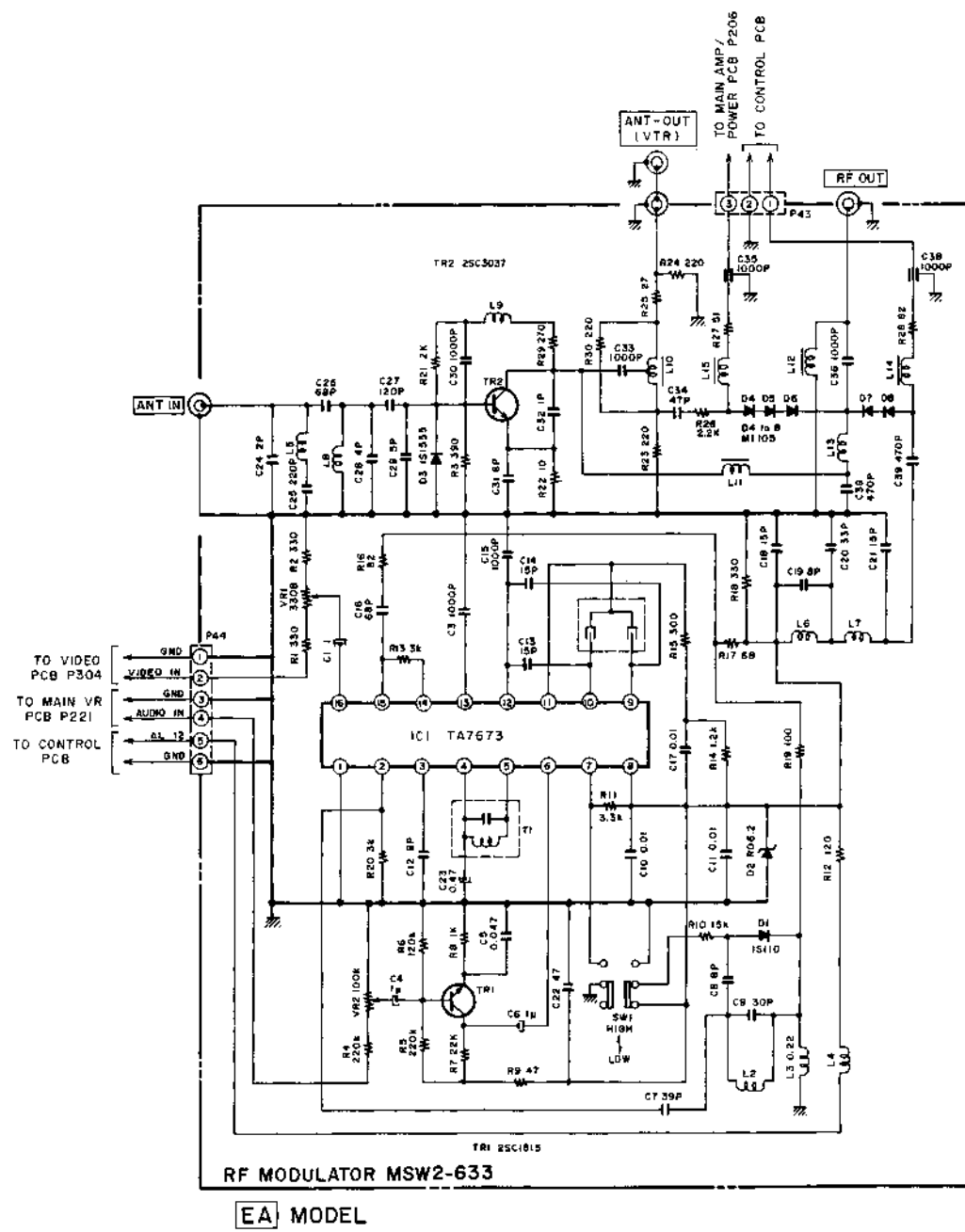

NOTE  
UNLESS OTHERWISE SPECIFIED  
ALL RESISTORS IN OHMS (1/4W(J))  
ALL CAPACITORS IN  $\mu$ F (50WV(J))

AV-U8EA/S  
RF MODULATOR  
SCHEMATIC DIAGRAM  
NO.7-6 831217A

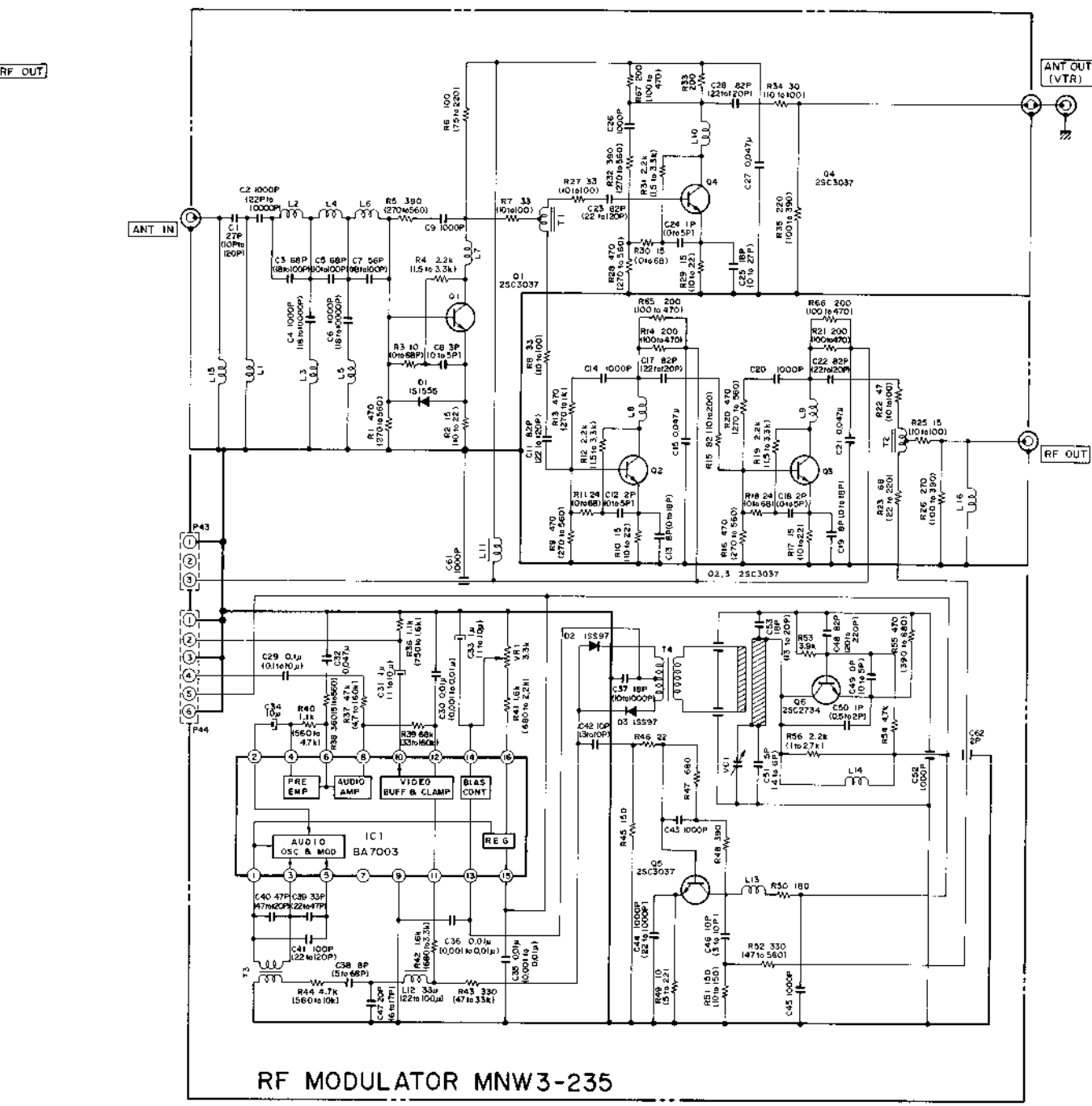
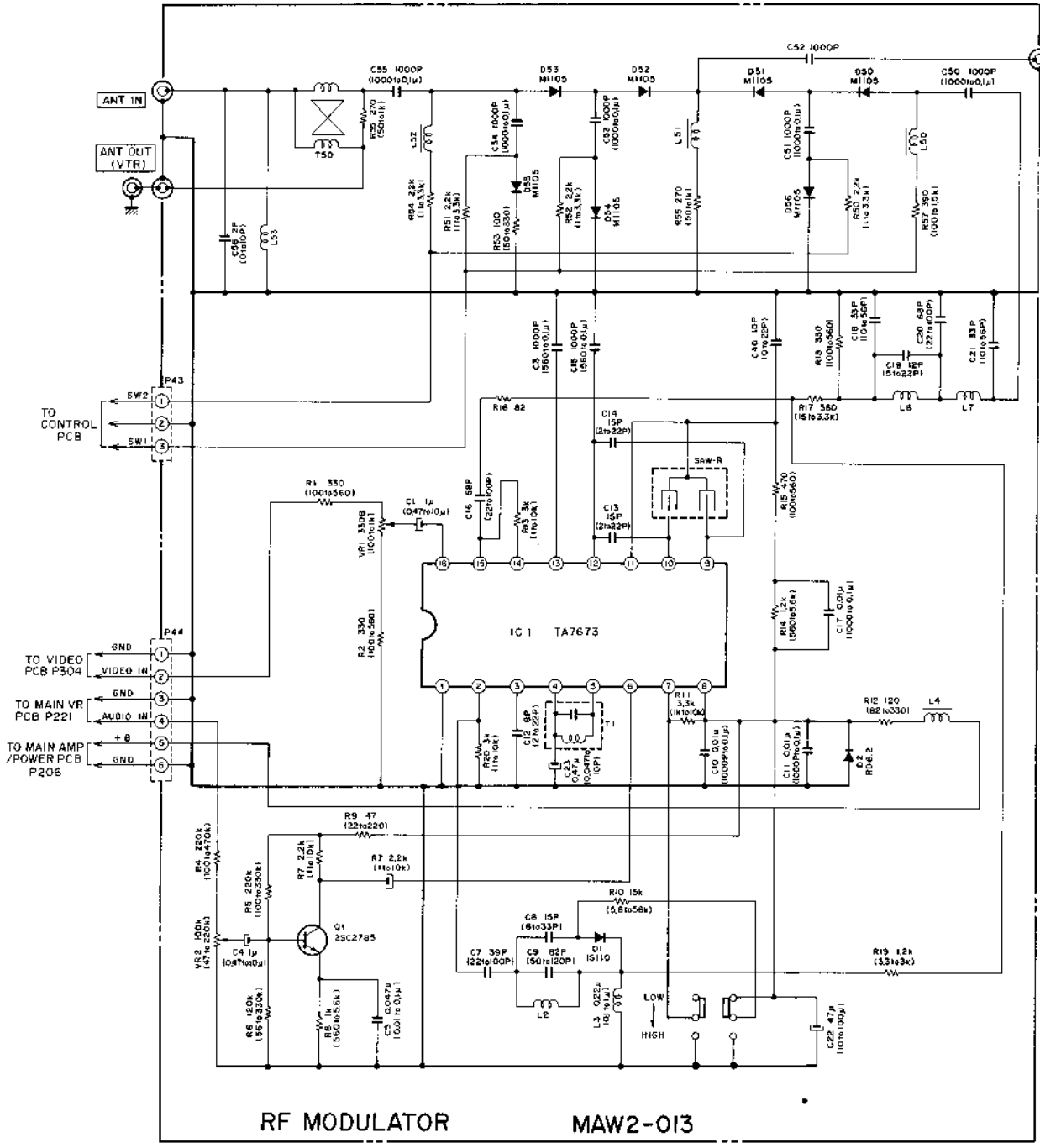
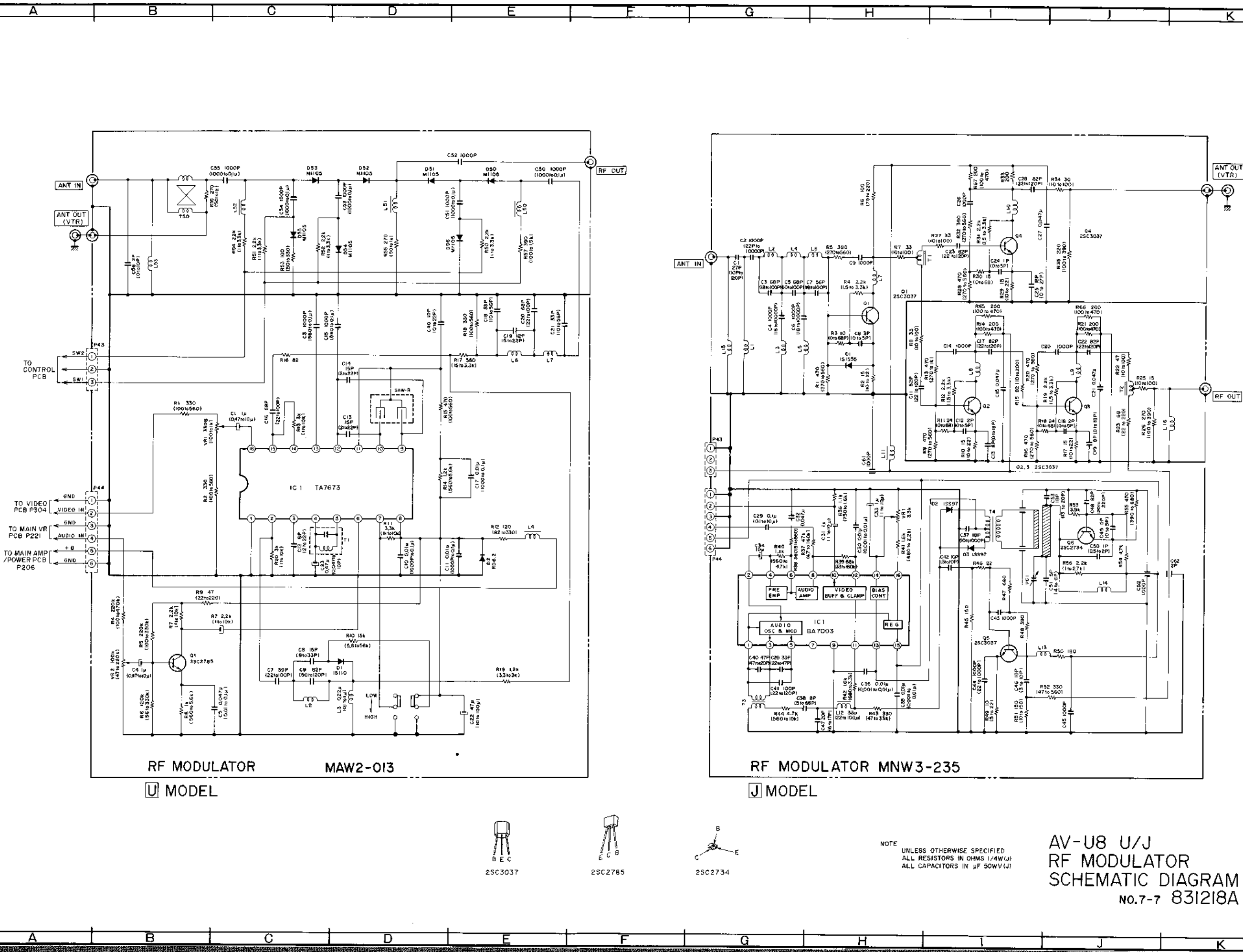

NOTE  
UNLESS OTHERWISE SPECIFIED  
ALL RESISTORS IN OHMS (1/4W/1)  
ALL CAPACITORS IN μF (50WV/1)

AV-U8 U/J  
RF MODULATOR  
SCHEMATIC DIAGRAM  
NO.7-7 831218A