

AKAI

X-200D

MODEL

SERVICE MANUAL



TABLE OF CONTENTS

I.	SPECIFICATIONS	1
II.	MEASURING METHOD	2
III.	DISMANTLING OF TAPE TRANSPORT UNIT & AMPLIFIERS	4
IV.	MECHANISM ADJUSTMENTS	6
V.	HEAD ADJUSTMENTS	7
VI.	AMPLIFIER ADJUSTMENTS	8
VII.	OPERATING PRINCIPLE	10
VIII.	COMPOSITE VIEWS OF COMPONENTS	11
IX.	SCHEMATIC DIAGRAM	

When placing order for parts,
please use separate PARTS LIST

I. SPECIFICATIONS

An asterisk next to a figure indicates the minimum guaranteed performance.

RECORDING SYSTEM	In-line 4-track stereo, monaural recording by using Cross-field Bias Head	
PLAYBACK SYSTEM	In-line 4-track stereo, monaural playback	
TAPE SPEED	7-1/2, 3-3/4 and 1-7/8 ips.	
TAPE SPEED DEVIATION	Within $\pm 0.7\%$ (* $\pm 0.8\%$)	
WOW AND FLUTTER	Less than 0.08% r.m.s. at 7-1/2 ips. (*0.12%) Less than 0.12% r.m.s. at 3-3/4 ips. (*0.25%) Less than 0.20% r.m.s. at 1-7/8 ips. (*0.35%)	
FREQUENCY RESPONSE	40 to 22,000 Hz ± 3 dB at 7-1/2 ips. 40 to 18,000 Hz ± 3 dB at 3-3/4 ips. 40 to 9,000 Hz ± 4 dB at 1-7/8 ips.	
SIGNAL TO NOISE RATIO	Better than 50 dB (Forward Operation) Better than 47 dB (Reverse Operation)	
DISTORTION	Within 2% at Line Output, 1,000 Hz "0" VU Recording and Playback (*2.5%)	
CROSS TALK	Less than -65 dB (Monaural) Less than -43 dB (Stereo)	
ERASE RATIO	Less than -70 dB	
OUTPUTS	Line output	Output Impedance: 100 Ω Required load impedance more than 25 k Ω 1.228V (+4 dB)
	Din output	0.4V Output Impedance: 10 k Ω Required load impedance more than 50 k Ω
INPUTS	Line input	Above 60 mV Impedance: 180 k Ω
	Din input	High: Above 60 mV Low: Above 6 mV Impedance: 150 k Ω Impedance: 27 k Ω
	Mic input	Above 0.5 mV Impedance: 5 k Ω
FAST FORWARD AND REWIND TIME	85 sec. for a full 1,200 foot tape at 50 Hz 65 sec. for a full 1,200 foot tape at 60 Hz	
MOTORS	Capstan motor	Hysteresis Synchronous 3-speed (2-4-8 pole) motor Condenser Capacity 3 μ F (50 Hz) 2 μ F (60 Hz) Revolutions: 3,000-1,500-750 r.p.m. (50 Hz) 3,600-1,800-900 r.p.m. (60 Hz)
	Reel motor	Two 6-pole eddy current outer-rotor motors Revolutions: 930 r.p.m. at 50 Hz 100V 1,120 r.p.m. at 60 Hz 110V
HEADS	Rec/Playback Head	In-line 4-track stereo and monaural Impedance: 1,200 Ω at 1,000 Hz Gap: 2/1,000 mm
	Erase Head	In-line 4-track stereo Impedance: 500 Ω at 60 kHz Gap: 0.2 mm
	Bias Head	In-line 4-track stereo Impedance: 500 Ω at 60 kHz Gap: 0.2 mm
BIAS FREQUENCY	93 \pm 5 kHz	
TRANSISTORS	4 ... 2SC693FU 5 ... 2SC372 2 ... 2SC458 (B) 2 ... 2SC971 1 ... 2SD223 (Y)	
IC	2 ... 1AA-072D	
DIODES	1 ... SB-3-01P 3 ... 1N34A 1 ... 10D4 8 ... 1N46A 3 ... V06C 1 ... RD24A (M)	
REEL CAPACITY	Up to 7" reel	
POWER SUPPLY	100V to 240V A.C., 50/60 Hz	
POWER CONSUMPTION	100W	
INSULATION RESISTANCE	More than 50 M Ω	
INSULATION DURABILITY	1 kV A.C. for more than 1 minute	
DIMENSIONS	374 (W) \times 362 (H) \times 245 (D) mm (14.7" \times 14" \times 9.6")	
WEIGHT	16.6 kg (36.5 lbs.)	

II. MEASURING METHOD

1. TAPE SPEED DEVIATION

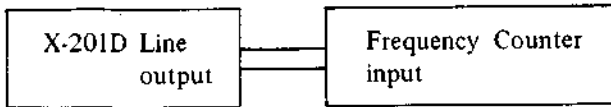

Fig. 1

As shown in Fig. 1, connect a Frequency Counter to the Line Output of Model X-201D. Take a frequency counter reading at the beginning, and end of tape winding during playback. The maximum value of these readings will represent tape speed deviation.

2. WOW AND FLUTTER

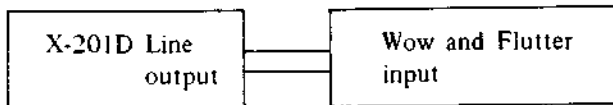

Fig. 2

Method A

As shown in Fig. 2, connect the Line Output of Model X-201D to the Input of a Wow and Flutter Meter. Use a 3,000 Hz pre-recorded test tape and take a wow and flutter meter reading at the beginning, and end of tape winding. The maximum value of these readings will represent the wow and flutter.

Method B

Supply a 3,000 Hz sine wave signal from an Audio Frequency Oscillator and make a recording on a blank tape at the beginning, and end of tape winding. Rewind and play tape. Measure wow and flutter with a Wow and Flutter Meter. (The wow and flutter value of Method B will be close to twice that of Method A.)

3. FREQUENCY RESPONSE

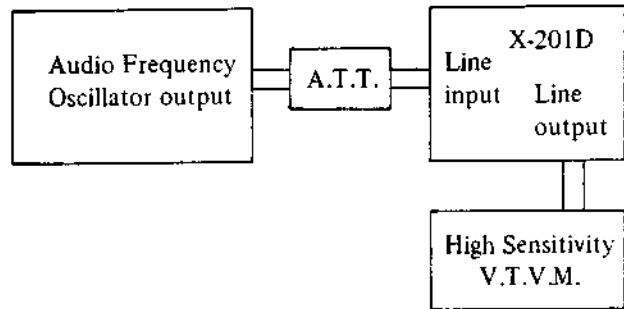

Fig. 3

For measuring frequency response, connect instruments as shown in Fig. 3 and proceed as follows:

- 1) Supply a 1,000 Hz sine wave to the Line Input of Model X-201D from an Audio Frequency Oscillator through an Attenuator. Set recorder to recording mode and turn recording level volume control to maximum. Adjust attenuator to obtain a +4 dB V.T.V.M. reading.
- 2) Under conditions described in 1) above, re-adjust attenuator so that the Line Output is -6 dB, and record 40 to 22,000 Hz spot frequencies.
- 3) Rewind tape and playback from the beginning. Take V.T.V.M. spot frequency readings and plot values on a graph.

Note: When measuring the frequency response, new tape should be used.

4. SIGNAL TO NOISE RATIO



Fig. 4

As shown in Fig. 4, connect a high sensitivity V.T.V.M. to the Line Output of Model X-201D. Play back a 333 Hz "0" VU pre-recorded test tape and measure the output. Then remove the tape and measure the noise level under the same condition. Convert each of the measured values into decibels.

5. TOTAL HARMONIC DISTORTION FACTOR

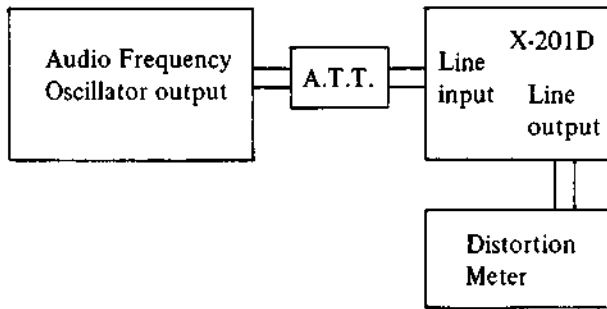

Fig. 5

Connect the measuring instruments as shown in Fig. 5 and record a 1,000 Hz sine wave signal at "0" VU. Playback the resultant signal and measure the overall distortion factor.

Measure the noise level of the tape recorder without the tape. Connect the audio oscillator directly to the distortion meter for measurement of the distortion factor of the oscillator. The required distortion factor can be obtained from the results of the above measurement by the following formula:

$$d_o = d - d_1 - d_2$$

where, d_o = Required distortion factor

d = Overall distortion factor

d_1 = Noise level

d_2 = Distortion factor of the oscillator

Note: When measuring the distortion factor, new tape should be used.

6. CROSS TALK (Cross talk between the tracks)

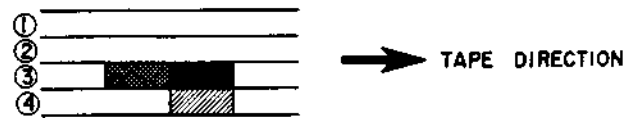

Fig. 6

As shown in Fig. 6, first record a 1,000 Hz sine wave signal on Track No. 3 at +3 VU Level. Next, record under a non-input condition. Then, playback the tape on Tracks No. 3 and 4 through the B.P.F. (band pass filter sensitivity 1:1) and obtain a ratio between the two from the following formula:

$$C = 20 \log \frac{E_o}{E_2 - E_1} \text{ (dB)}$$

where, C = Desired cross talk ratio (dB)

E_o = 1,000 Hz signal output level

E_2 = 1,000 Hz cross talk level

E_1 = Non-input signal recorded level

7. ERASE RATIO

As shown in Fig. 4, connect a high sensitivity V.T.V.M. to the Line Output of Model X-201D.

Playback a virgin tape and take a V.T.V.M. reading of the output level. Next, record a 1,000 Hz sine wave signal at +3 dB, then playback this recorded signal and take a V.T.V.M. reading of the output level. Next, using this pre-recorded tape, record under a non-input condition and take a reading of the noise level output of the erased signal and obtain a ratio between the two from the following formula:

$$Er = 20 \log \frac{E_o}{E_2 - E_1}$$

where, Er = Desired erase ratio (dB)

E_o = 1,000 Hz signal output level

E_2 = Non-Input signal recorded level

E_1 = Virgin tape noise output level

III. DISMANTLING OF TAPE TRANSPORT UNIT & AMPLIFIERS

In case of trouble, etc. necessitating disassembly, please disassemble in the order shown in photographs. Reassemble in reverse order.

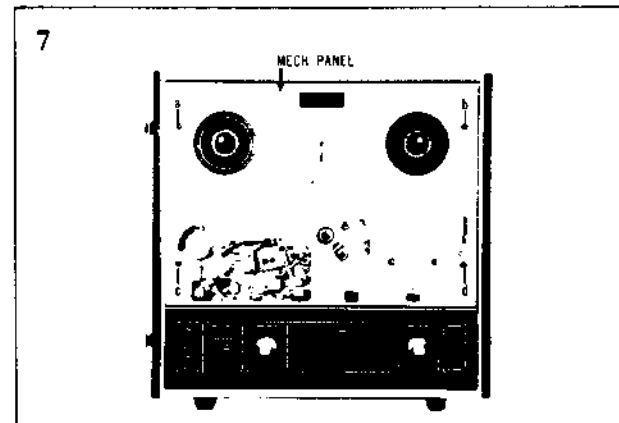
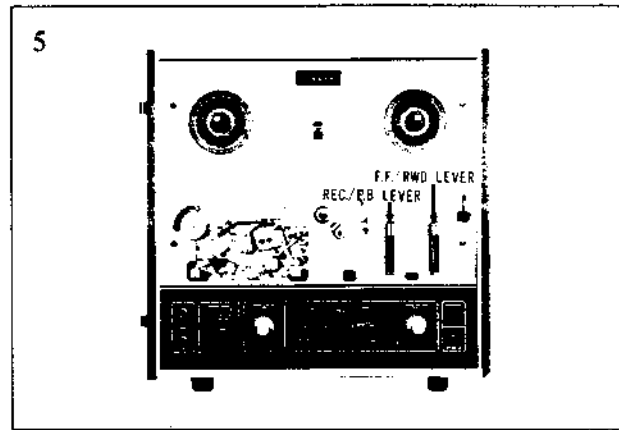
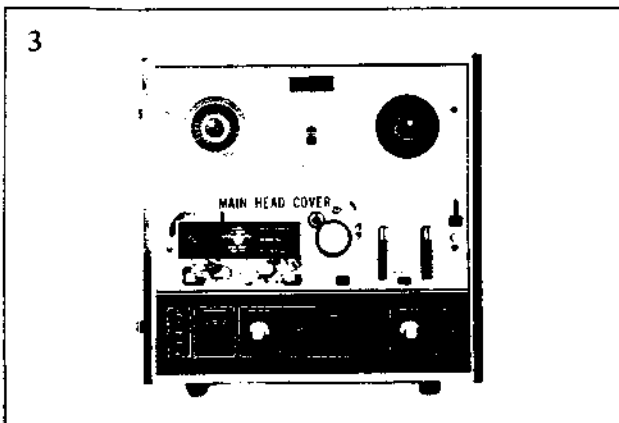

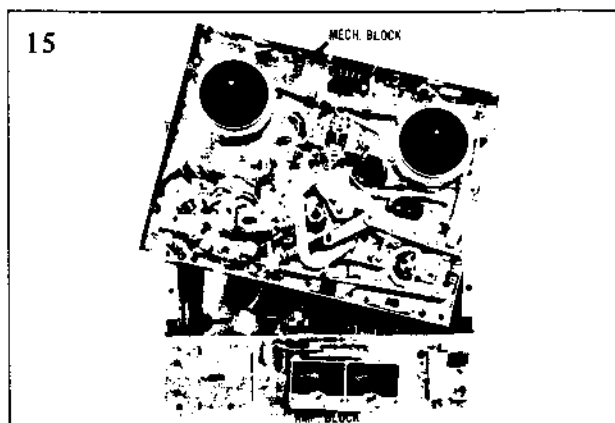
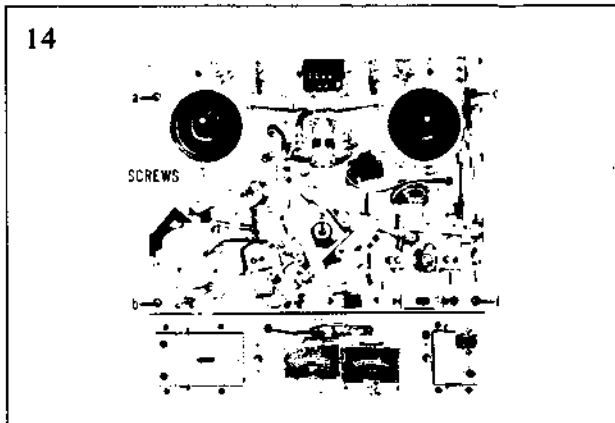
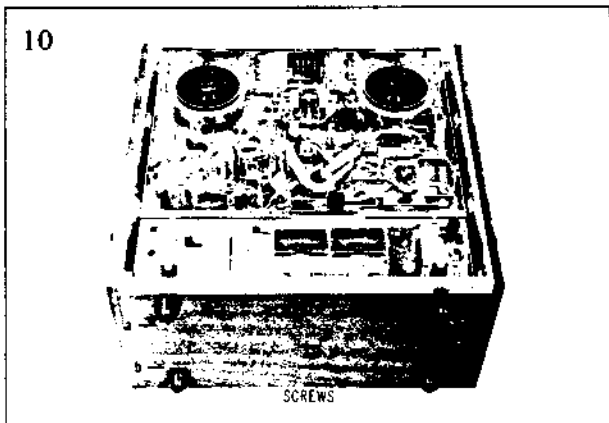
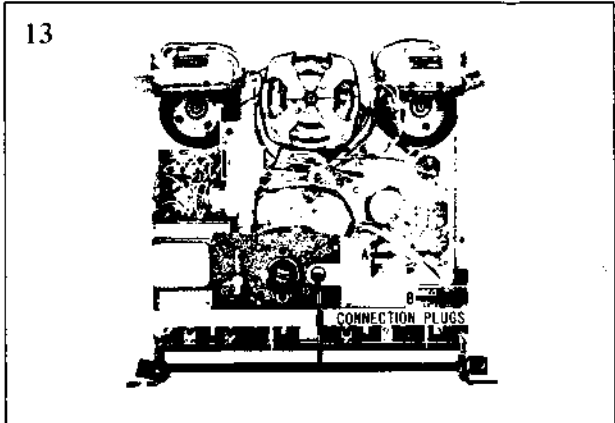
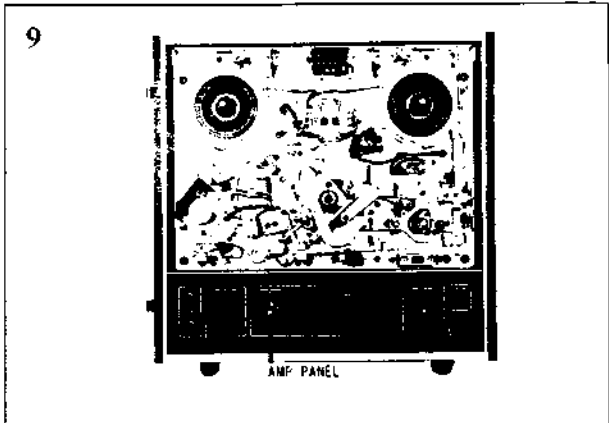
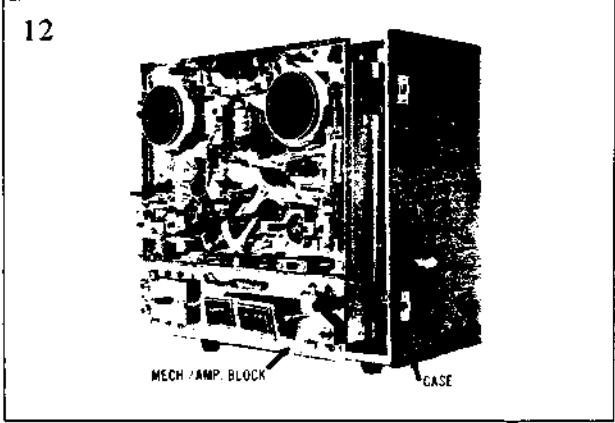
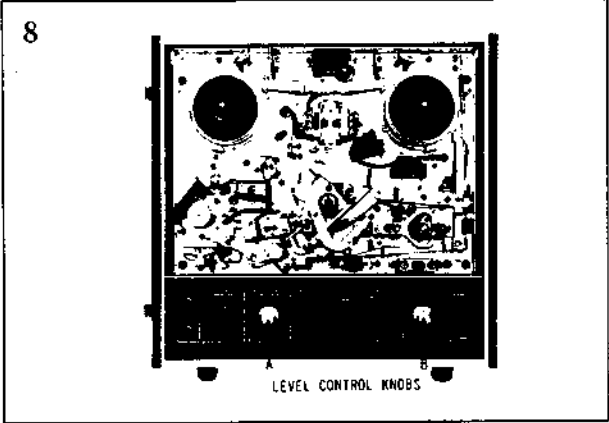

IV. MECHANISM ADJUSTMENTS

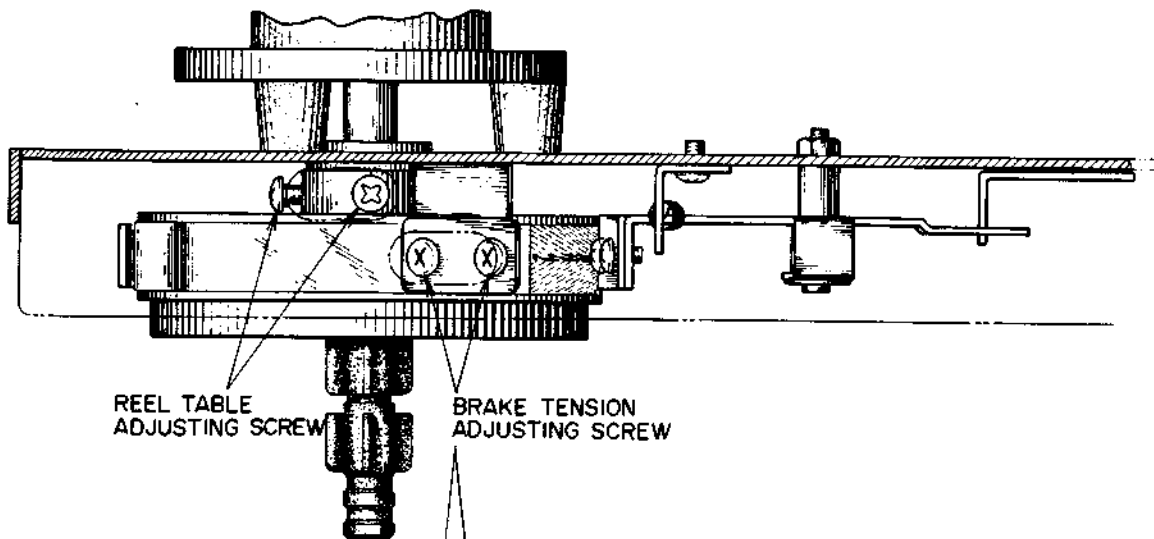

Fig. 7

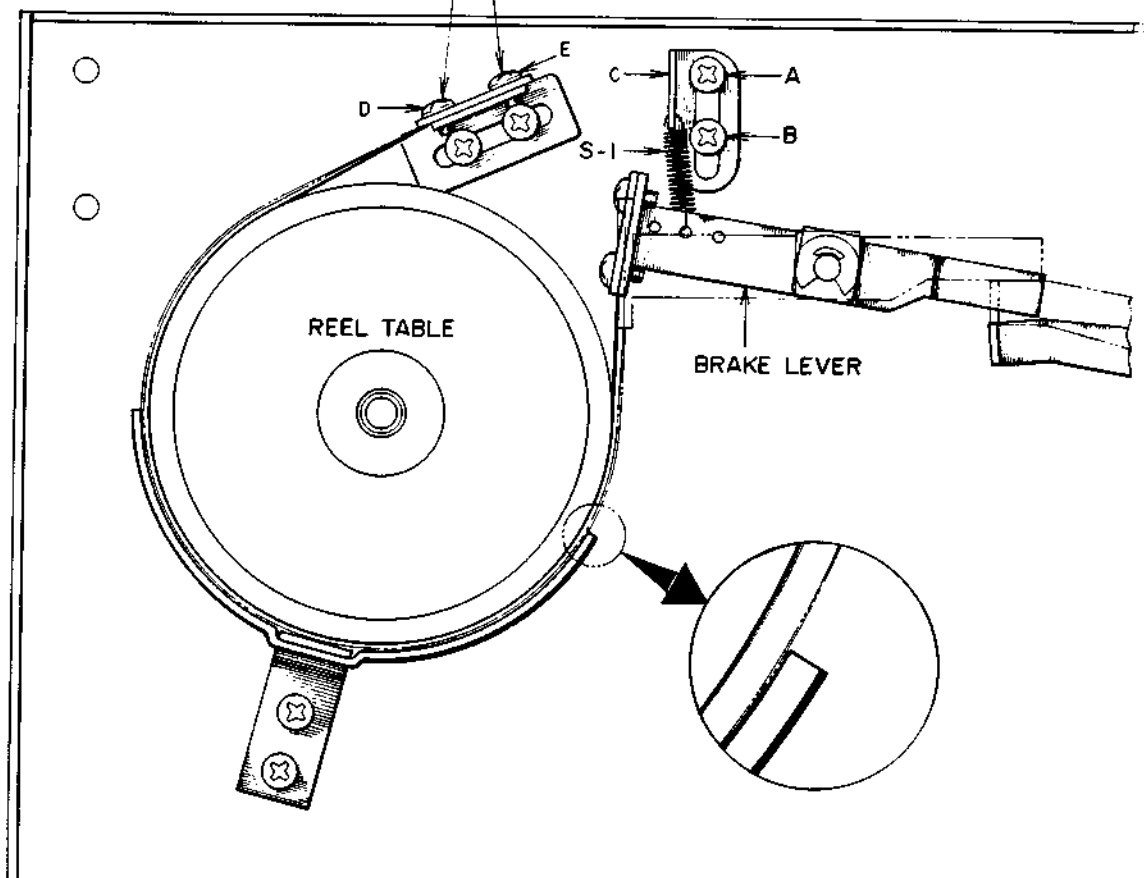

Fig. 8

1. REEL HEIGHT ADJUSTMENTS

Loosen Reel Table Screws and adjust reel table height (See Fig. 7).

2. BRAKE TENSION ADJUSTMENTS

(See Figs. 7, 8)

Using a tension gauge and a 60 mm tape wound on a 5" reel, to adjust tension, change the position of the suspended spring (S-1) or loosen screws (A, B) and adjust position of spring suspension metal (C) or loosen screws (D, E) and adjust position of the brake band so that the brake tension is 300 gr.

V. HEAD ADJUSTMENTS

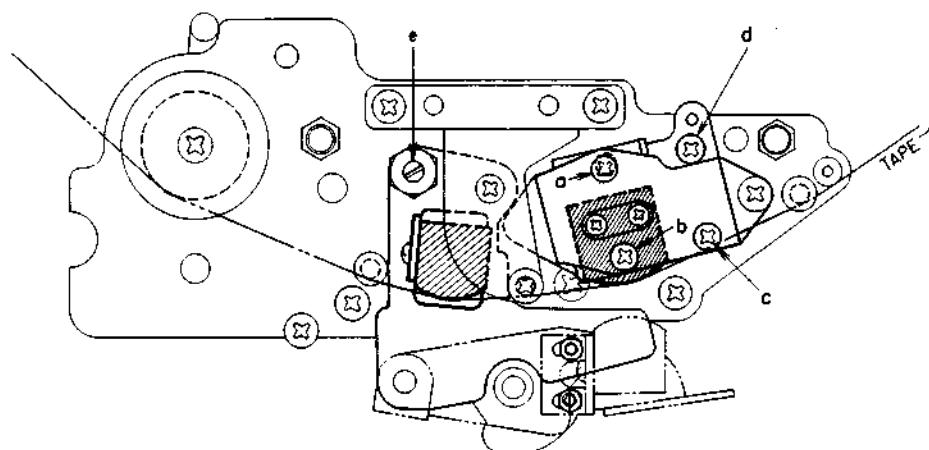

Fig. 9

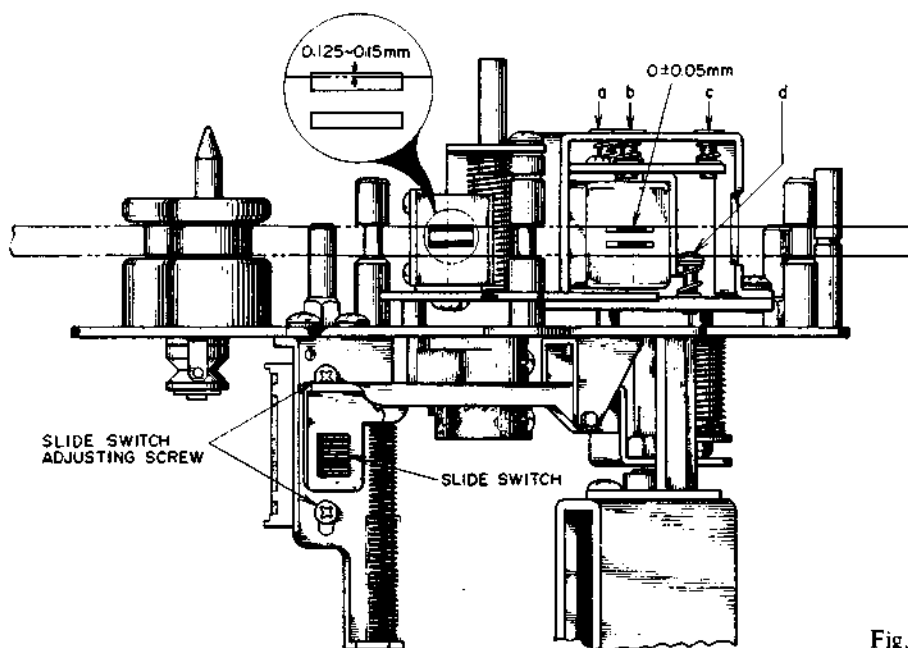

Fig. 10

1. HEAD HEIGHT ADJUSTMENTS

(See Figs. 9, 10)

- 1) To adjust, turn screws (a) (b) (c) (Fig. 9) During "Normal Play" position so that the upper edge of the upper core of the Playback/Rec Head is the same height as the upper edge of the tape. Adjust by turning screw (d) (Fig. 9) during "Reverse Play" position so that the lower edge of the lower core of the Playback/Rec Head is the same height as the lower edge of the tape.
- 2) Erasing Head
Adjust screw (H) so that the upper edge of the upper core is 0.125 to 0.15 mm higher than the upper edge of the tape. In adjusting Head Height, make sure that the front of the Head is at right angles to the Chassis and that the upper and lower part of the Head firmly contacts the tape.

2. AZIMUTH ALIGNMENT ADJUSTMENTS

(See Fig. 9)

Playback/Rec Head

Use a pre-recorded tape (16 kHz, 7-1/2 ips.), and connect a high sensitivity V.T.V.M. to the line output jack. Adjust screws (C) (E) so that line output voltage is maximum.

VI. AMPLIFIFR ADJUSTMENTS

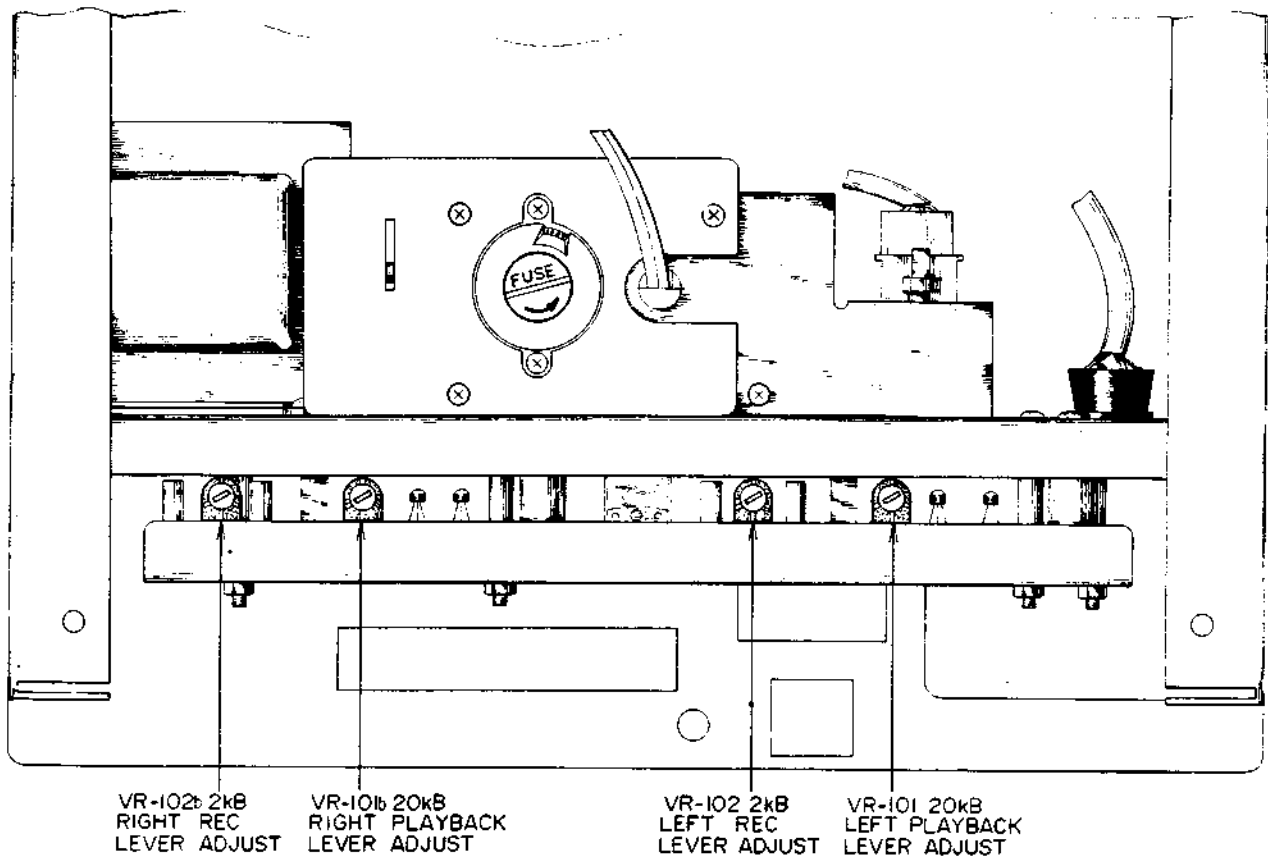

Fig. 11

1. PLAYBACK OUTPUT LEVEL ADJUSTMENTS (See Fig. 11)

- a) Connect a high sensitivity V.T.V.M. to the Line Output jack.
- b) Set the Tape Speed Selector Switch to the "7-1/2" position.
- c) Playback a 250 Hz pre-recorded tape.
- d) Adjust the Semi-fixed Resistor VR-101 (20k B) of the pre-amplifier so that Line Output Voltage indicates 1.228V (± 4 dbm).

2. RECORDING LEVEL ADJUSTMENTS

Recording Amplifier Adjustment should be made only after Head adjustment (vertical and horizontal azimuth) and Playback Amplifier Adjustments have been made.

- 1) As shown in Fig. 12, connect an Audio Oscillator and Attenuator to the Line Input. Connect a High-sensitivity V.T.V.M. to the Line Output.
- 2) Set Equalizer Switch and Tape Speed Selector to "7-1/2".
- 3) Load a blank test tape on the tape recorder and set the Rec/Playback Knob to "Rec" position.
- 4) Supply a 1000 Hz signal from the audio oscillator to the Line Input, and adjust the volume control so that the VU Meter indicates "0" VU (intermediate between red and black).
- 5) Record the tape and check playback to see whether the VU Meter indicates "0" VU.
- 6) If the pointer of the VU Meter fails to register "0" VU, repeat recording and playback by adjusting the Semi-fixed Resistor VR-102 (2k B) of the recording pre-amplifier until the "0" VU reading is obtained both on recording and playback.

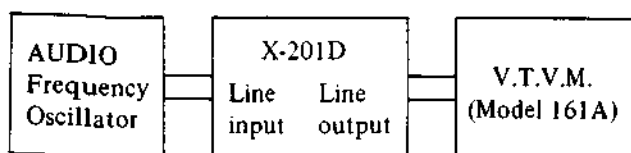

Fig. 12

3. ADJUSTMENT OF RECORDING BLAS FREQUENCY AND VOLTAGE

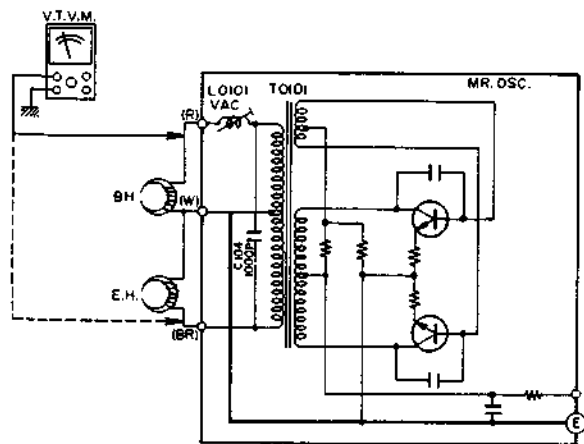

Fig. 13

Proper Bias Frequency of the X-201D is 93 ± 5 kHz. The frequency can be adjusted by converting the value of the condenser (C-104 1000p) and L0101 (VAC). Proper Bias Voltage is 105V (± 2 V). The voltage can be adjusted by turning the V.A.C. (L0101) in the bias oscillator circuit.

Erasing Voltage is 90V (± 5 dB).

VII. OPERATING PRINCIPLE

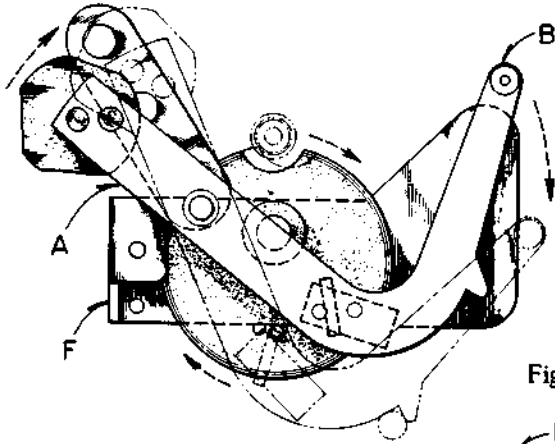

Fig. 14

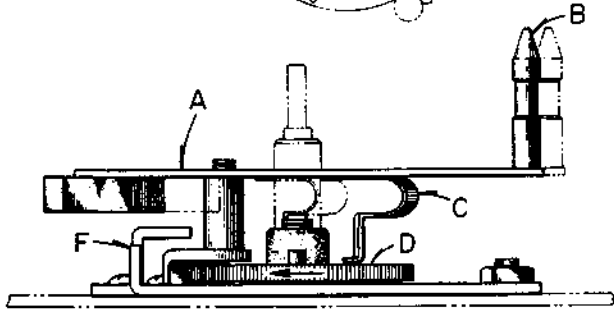

Fig. 15

AUTOMATIC STOP MECHANISM

When the tape is threaded on pin (B), if the tape is accidentally broken or comes to the end, Automatic Stop Lever (A) drops to its original position.

When the tape is broken or comes to the end, Plate Spring (C), located below the Automatic Stop Lever, depresses a projected pin on Eccentric Gear (D). Eccentric Gear (D) gears into Flywheel (E) to begin rotation of the Eccentric Gear. This rotating action operates Lever (L), which is connected to the base of the Eccentric Gear, and pushes up Instant Stop Lever (G). When Instant Stop Lever (G) is lifted, Shut-off Lever (J) contacts Micro Switch (K) and the current supply is cut off. Thus, automatic stop control is provided in Recording and Playback modes.

In Fast Forward and Rewind modes, the same operation takes place except that Lever (H) works to push back the FF, Rewind Shaft to "Stop" position.

(See Figs. 14 to 17)

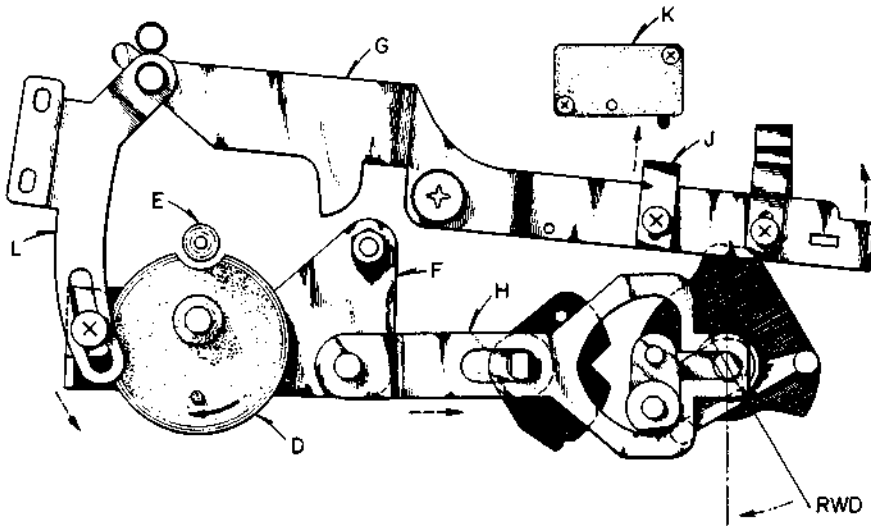

Fig. 16

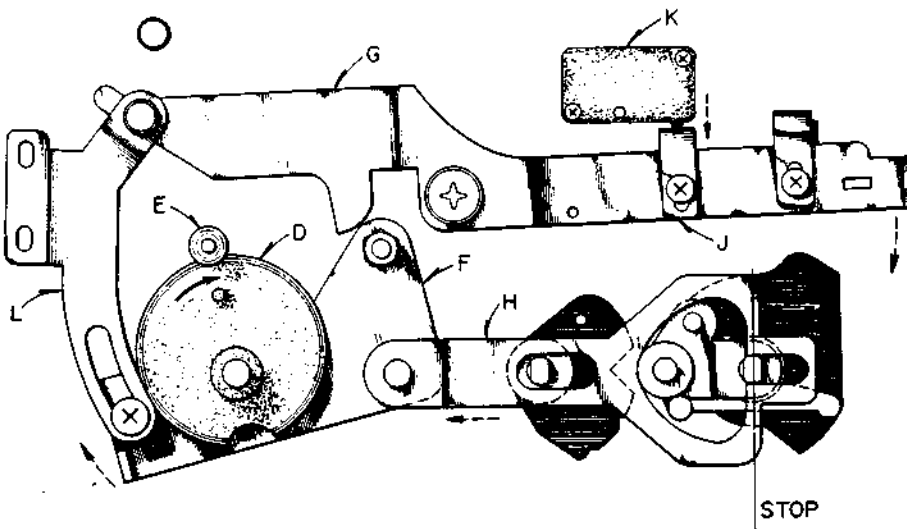
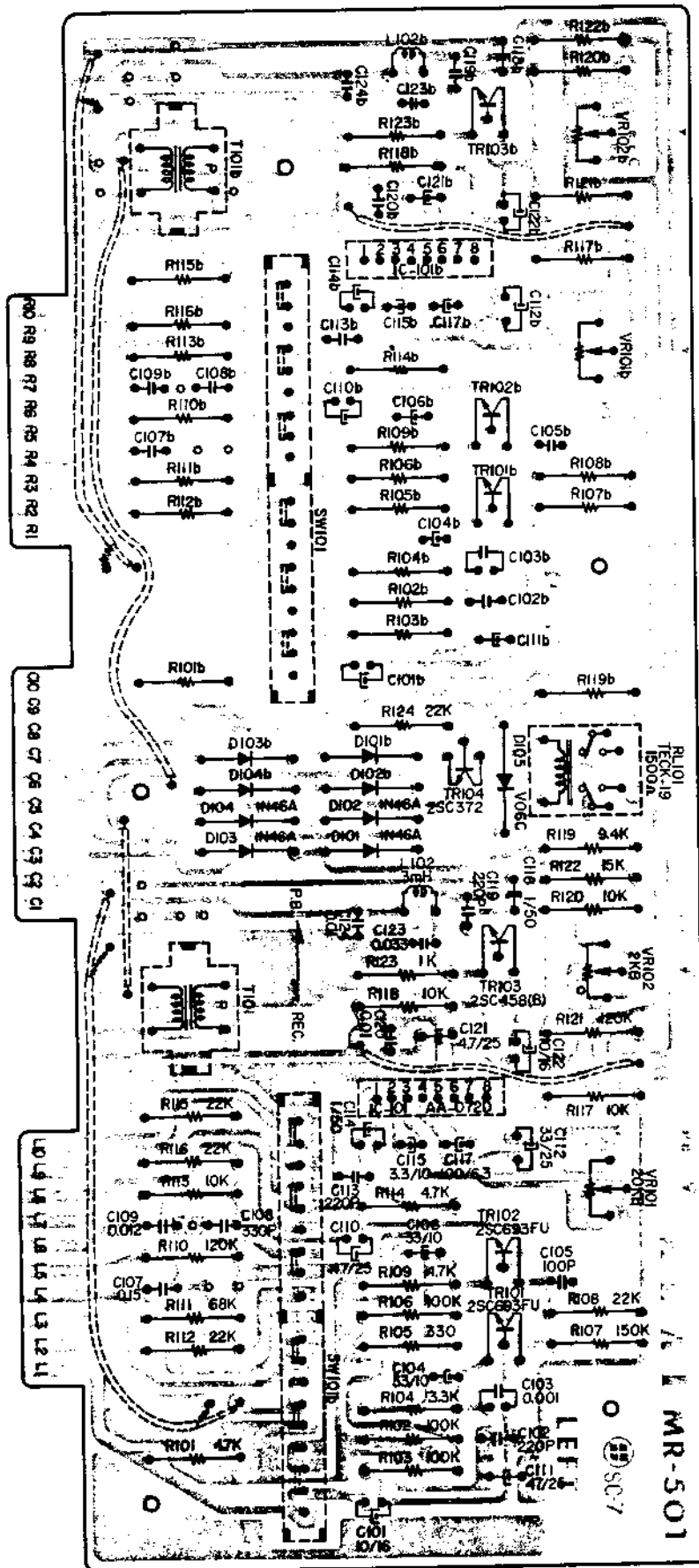

Fig. 17

VIII. COMPOSITE VIEWS OF COMPONENTS

PRE-AMPLIFIER P.C. BOARD (MR-501)



EQUALIZER P.C. BOARD (MR-502)

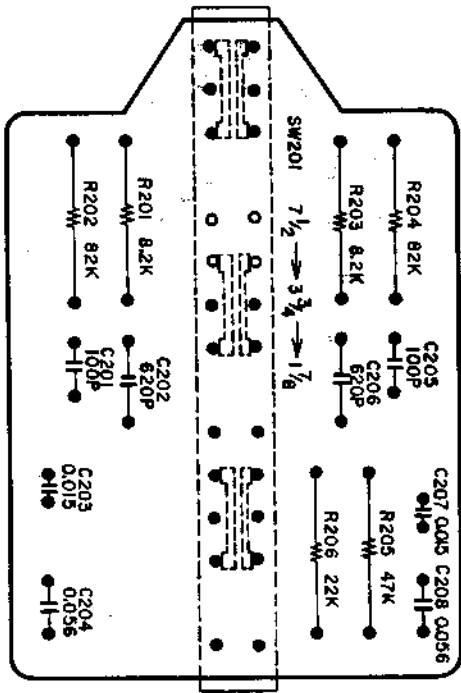

POWER SUPPLY P.C. BOARD (MR-503)

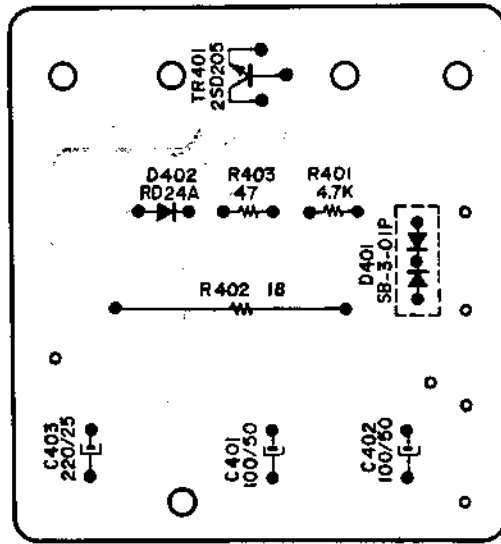

SYSTEM CONTROL P.C. BOARD (MR-504)

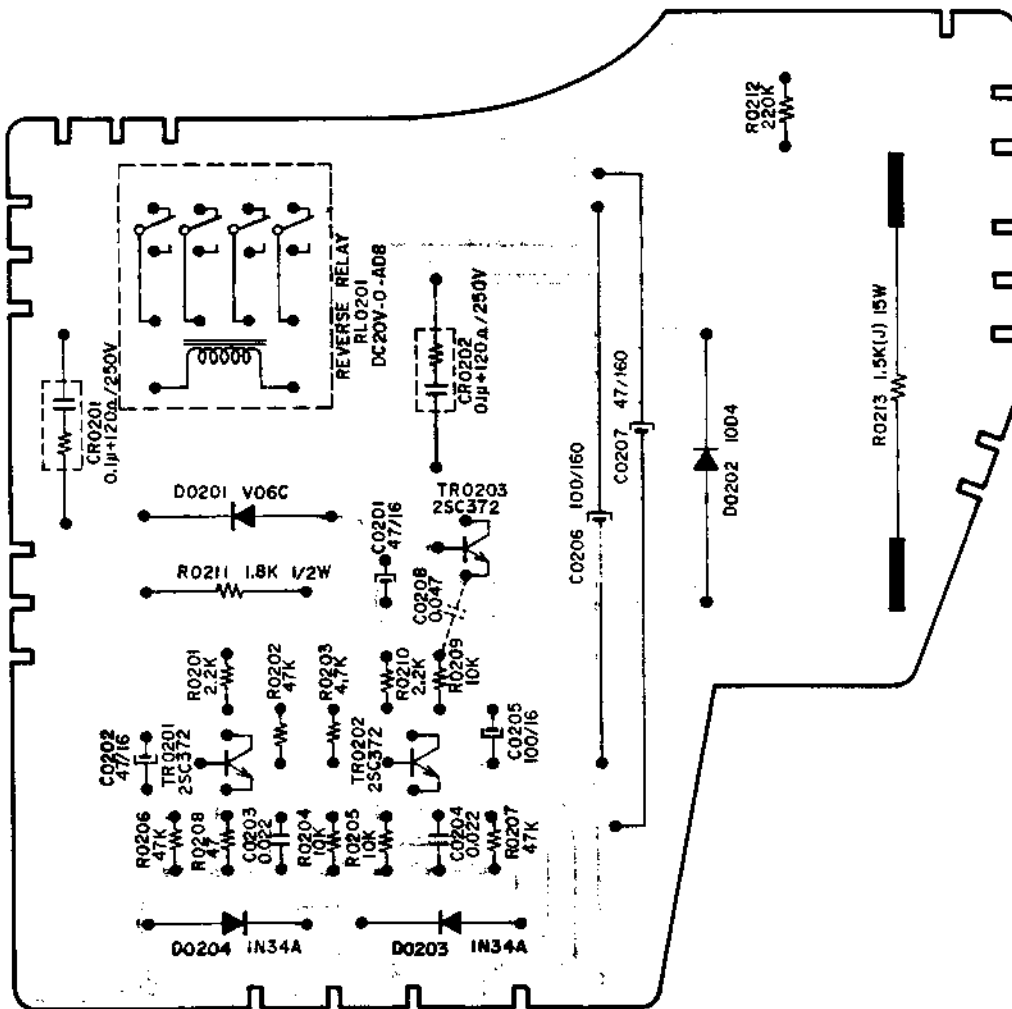

O.S.C. P.C. BOARD (MR-505)

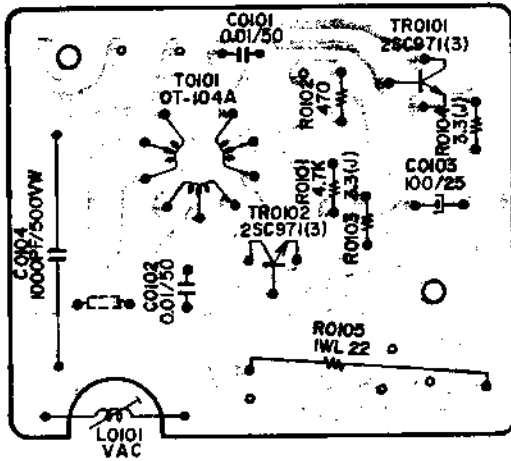

SPARK QUENCHER P.C. BOARD (MR-507)

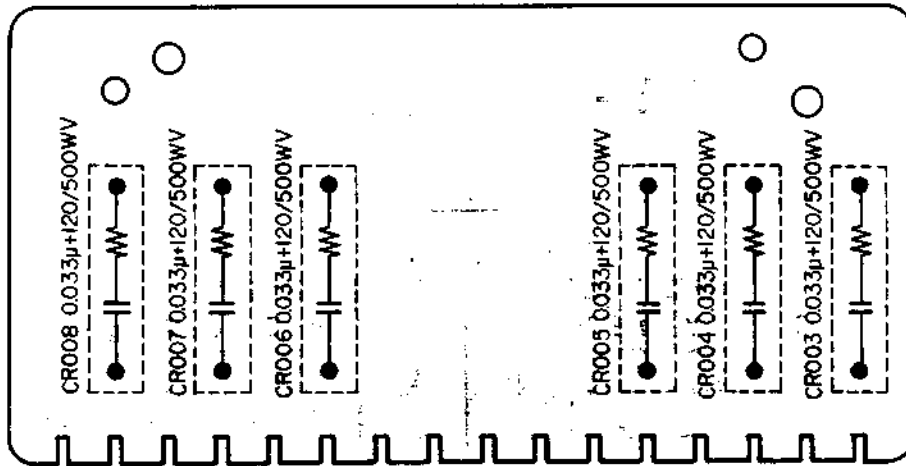

TENSION RELAY P.C. BOARD (MR-558)

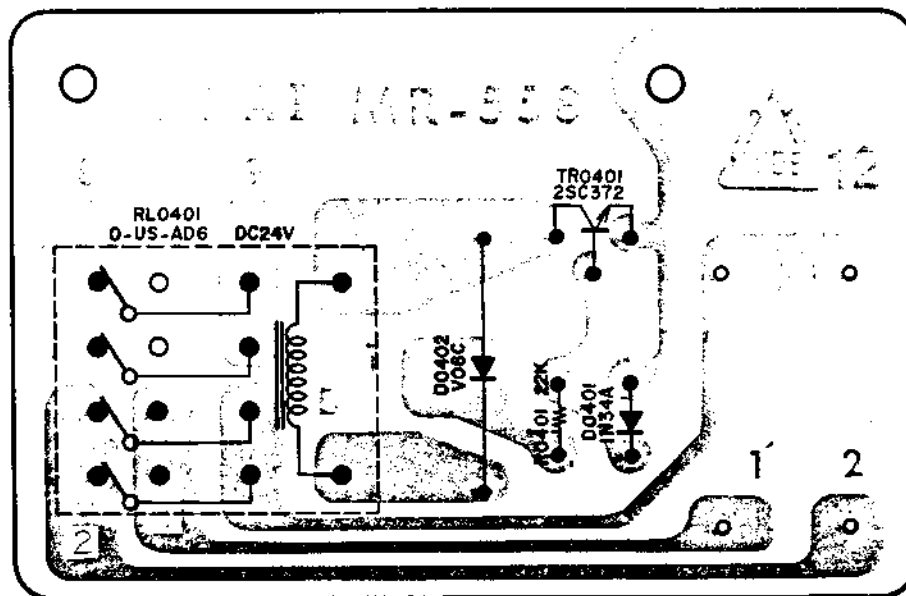

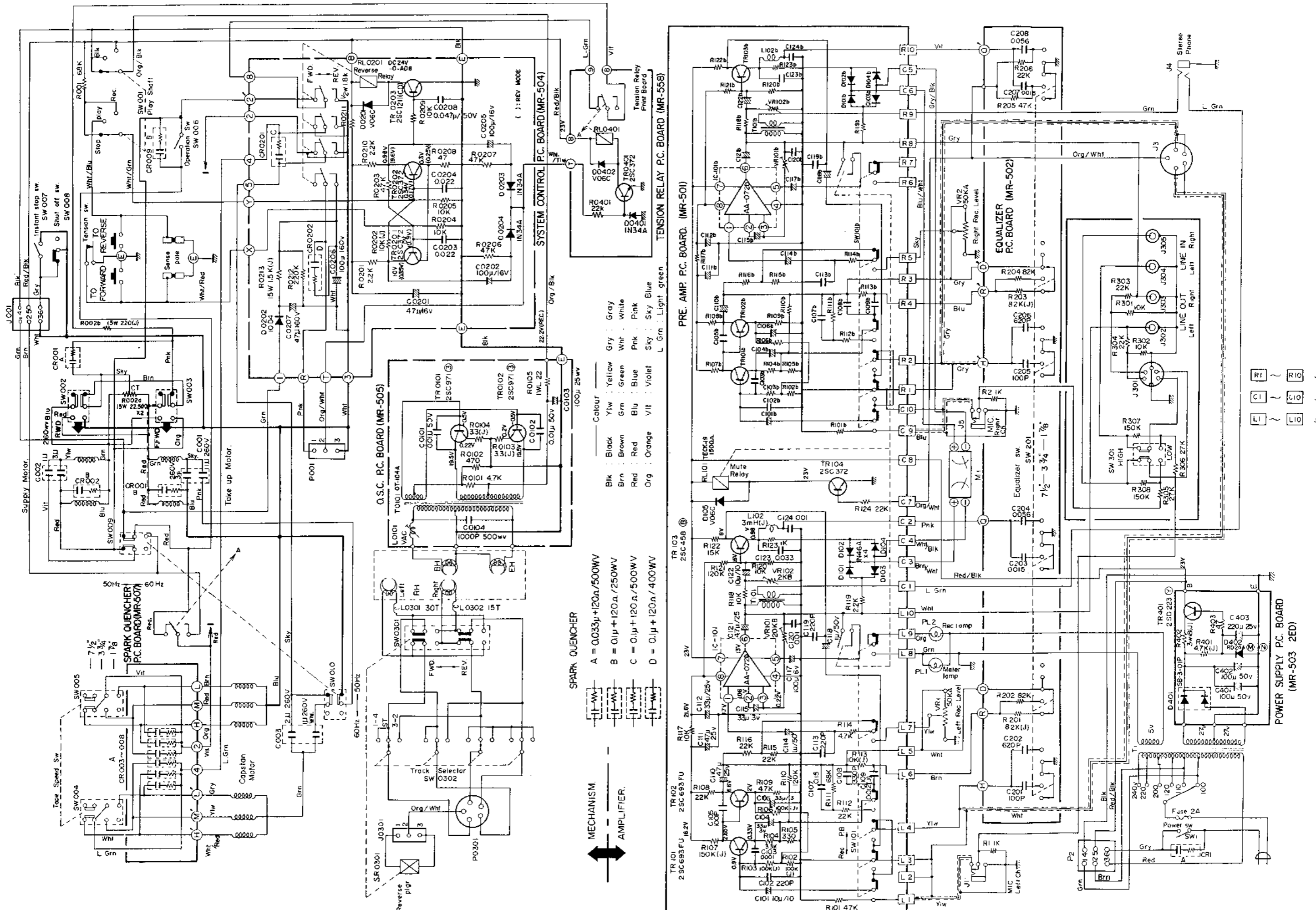

X-201D SCHEMATIC DIAGRAM 1440820A