

AKAI SERVICE MANUAL

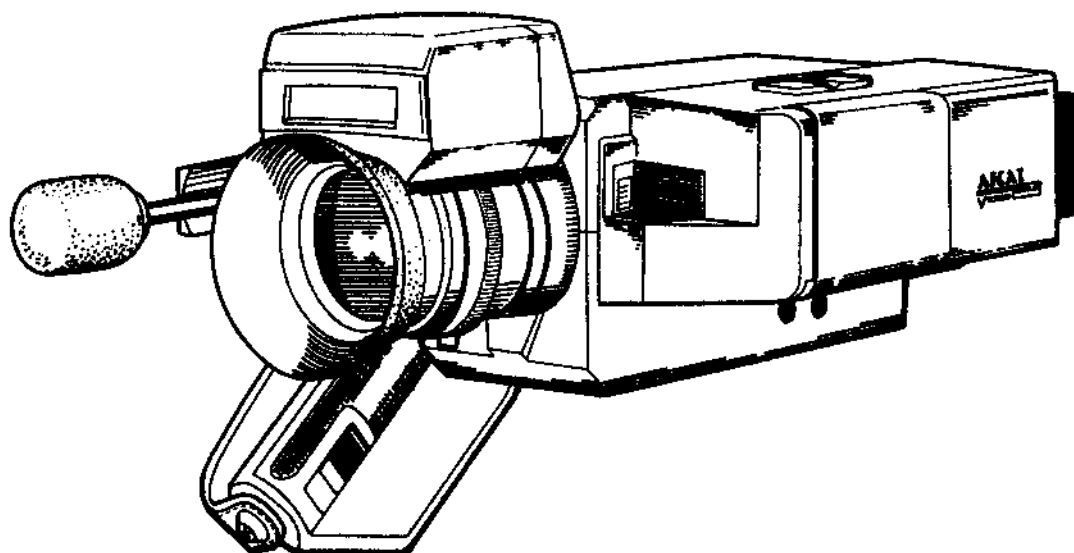

COLOR VIDEO CAMERA (NTSC)

MODEL **VC-X1U**

VC-X1U

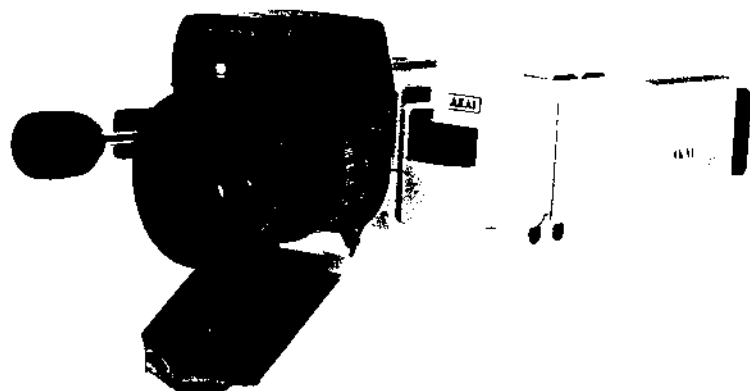

COLOR VIDEO CAMERA (NTSC)

MODEL **VC-X1U**

SECTION 1	SERVICE MANUAL	3
SECTION 2	PARTS LIST	47
SECTION 3	SCHEMATIC DIAGRAM	56

SECTION 1

SERVICE MANUAL

TABLE OF CONTENTS

I.	SPECIFICATIONS	4
II.	DISMANTLING OF UNIT	5
III.	CONTROLS	7
IV.	PRINCIPAL PARTS LOCATION	8
V.	EXPLANATION OF VC-X1 CIRCUITRY	10
	1. FEATURES OF VC-X1	10
	2. EXPLANATION OF CIRCUITRY	12
VI.	ADJUSTMENT	24
	1. TOOLS, ETC. REQUIRED FOR ADJUSTMENT	24
	2. ADJUSTING THE CAMERA PROPER	25
	3. ADJUSTING THE EVF BLOCK	36
VII.	CLASSIFICATION OF VARIOUS P.C BOARDS	38
	1. P.C BOARD TITLES AND IDENTIFICATION NUMBERS	38
	2. COMPOSITION OF VARIOUS P.C BOARDS	39

I. SPECIFICATIONS

PICKUP TUBE	Single tube, 2 3/4" vidicon
PICKUP SYSTEM	Uni-carrier Frequency Separation System
SCANNING SYSTEM	2:1 interlaced (525 lines)
SIGNAL SYSTEM	NTSC Color System
HORIZONTAL RESOLUTION	More than 270 lines (center)
VIDEO S/N	More than 46 dB (luminance channel)
VIDEO OUTPUT	1.0 Vp-p, 75 ohms (unbalanced)
SYNCHRONIZATION SYSTEM	Internal Synchronization System (built-in Synchronization Signal Generator)
AUTOMATIC SENSITIVITY ADJUSTMENT RANGE	50 lux to 64,000 lux (without built-in ND filter) 400 lux to 500,000 lux (with built-in ND filter)
COLOR TEMPERATURE	AUTO MANUAL Incandescent lamp or Day light (automatically switchable) Incandescent lamp, Fluorescence lamp and Day light (switchable)
MINIMUM PRACTICAL ILLUMINATION	More than 50 lux (F1.4)
MICROPHONE	Uni-directional electret condenser microphone
AUDIO OUTPUT	-20 dB (low impedance)
AUDIO S/N	More than 40 dB
EXTERNAL MICROPHONE INPUT	-66 dB, 2 kohms, 3.5 mmφ jack
LENS	F1.4, x6 zoom lens (f = 11 mm to 70 mm) with MACRO. Manual/2-speed motor driven Zooming control. Switchable Auto/Manual IRIS control. Filter Diameter = 58 mm (fixed zoom lens)
VIEW FINDER	1.5" Electronic View Finder
REMOTE CONTROL JACK	2.5 mmφ
SPECIAL FEATURES	One-touch fade-in and fade-out system Switchable luminance and chrominance (color) signal polarities
OPERATING TEMPERATURE	32°F to 104°F (0°C to 40°C) • In cold temperatures, the auto zoom will move slowly. In such cases, zoom-in/out manually.
POWER REQUIREMENT	12 VDC
POWER CONSUMPTION	7.6W (at Auto Focus "MANU." position) 11.0W (Maximum Power Consumption)
DIMENSIONS	8.5(W) x 5.2(H) x 13.9(D) inches (216 x 132 x 352) mm (With lens and eye hood, auto focus unit, hand grip and microphone retracted position)
WEIGHT	5.5 lbs (2.5 kg) (with lens and eye hood, hand grip and microphone)

* For improvement purposes, specifications and design are subject to change without notice.

II. DISMANTLING OF UNIT

In case of trouble, etc. necessitating dismantling, please dismantle in the order shown in the photographs. Reassemble in reverse order.

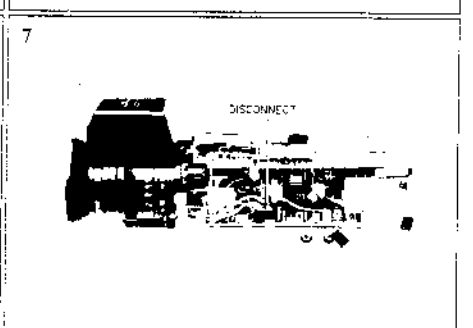
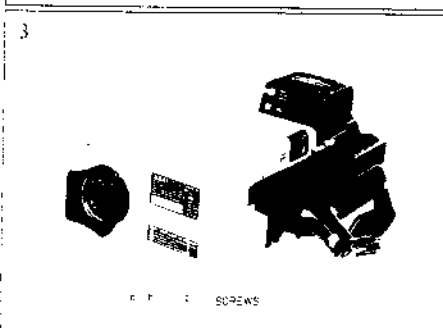
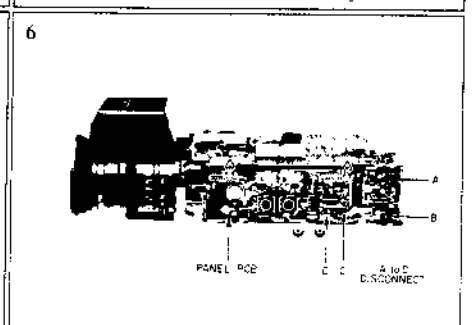
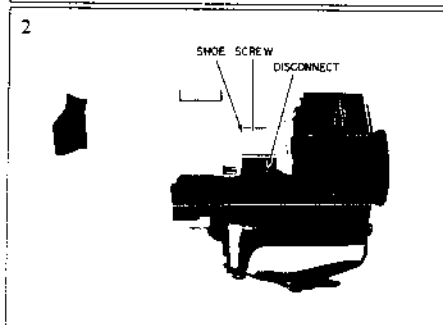
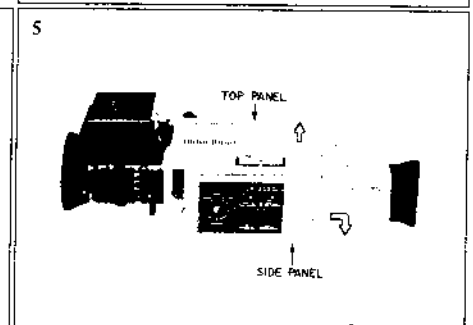
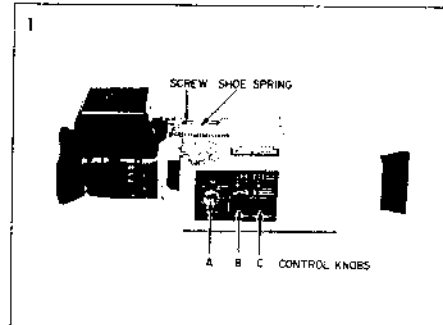
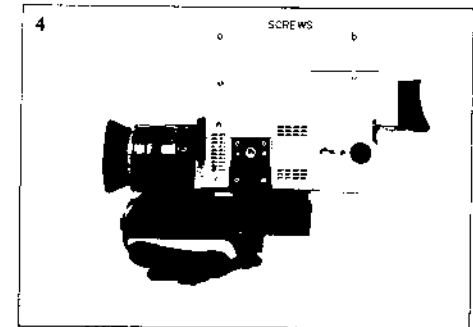

III. CONTROLS

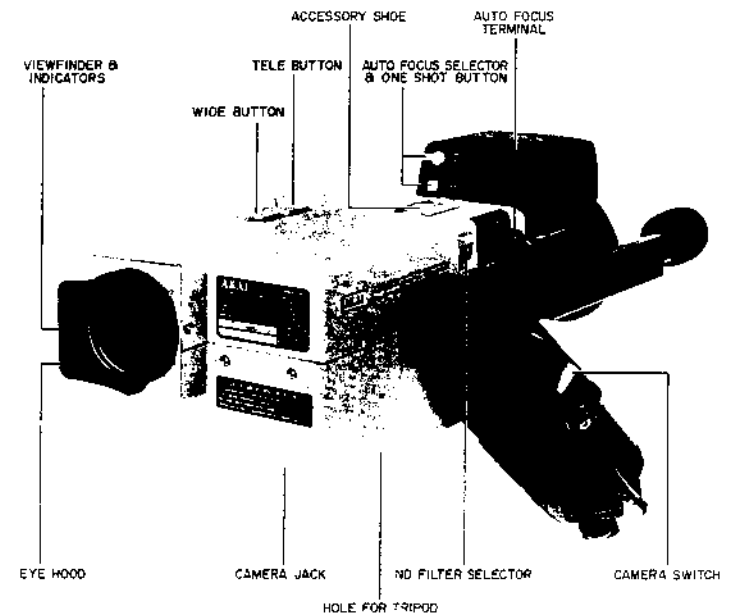
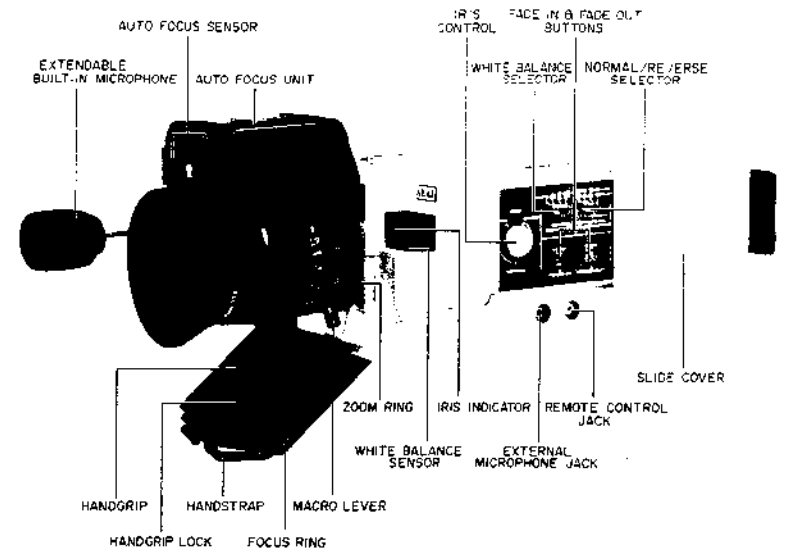
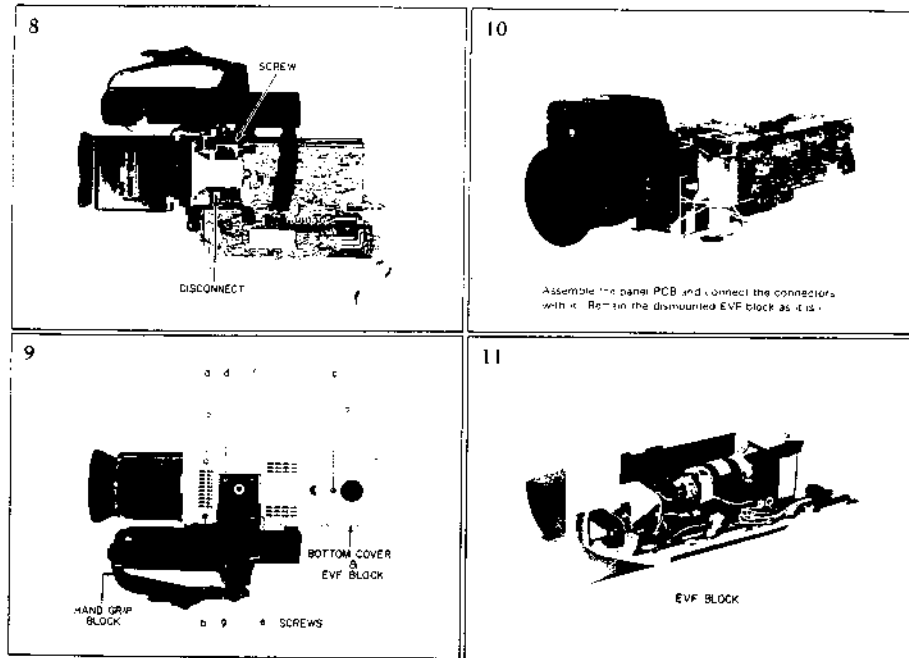

Fig. 1 Controls

IV. PRINCIPAL PARTS LOCATION

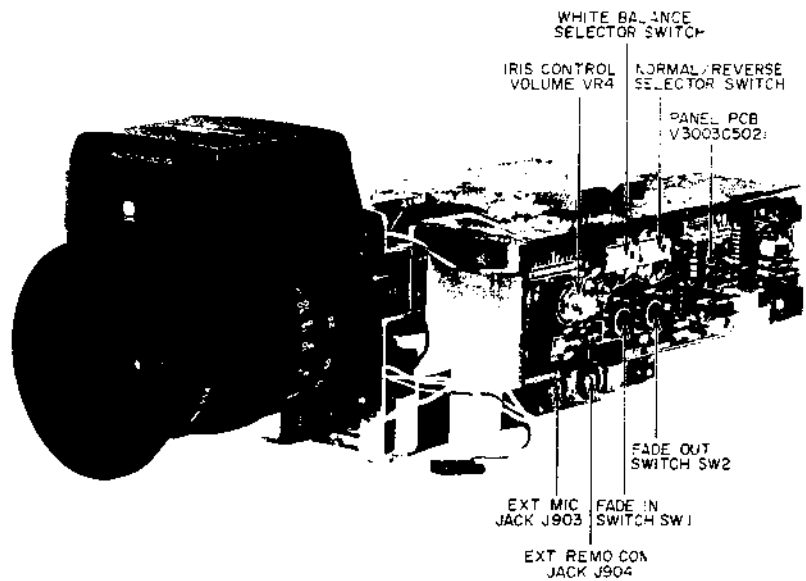

Fig. 2

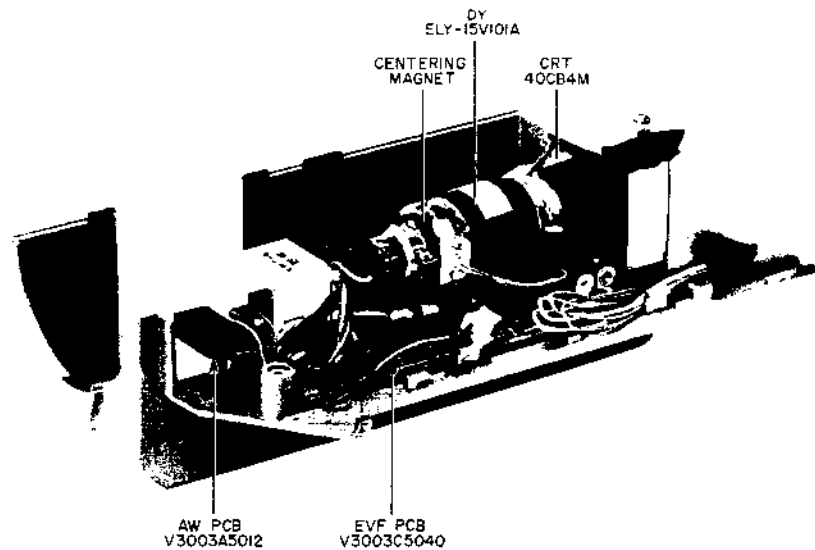

Fig. 4 EVF Block

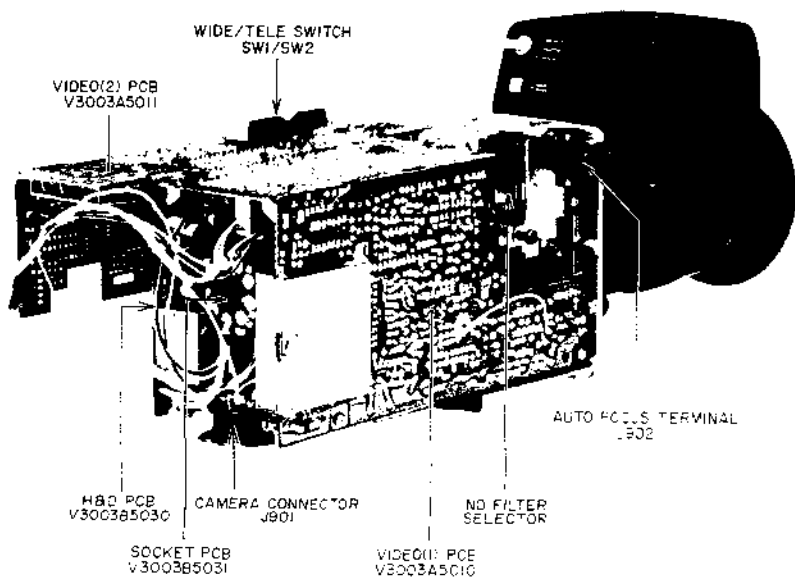

Fig. 3

V. EXPLANATION OF VC-X1 CIRCUITRY

1. FEATURES OF VC-X1

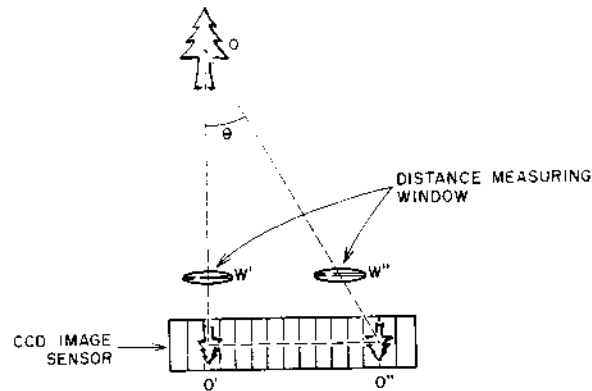

Fig. 5

1-1. Automatic Focus Control

The automatic focus adjusting unit employed on the VC-X1 provides focus adjustment in digital control mode through the use of a solid-state triangulation system (SSTS). Its major advantages are high accuracy, high sensitivity and elimination of unwanted noises.

The distance of the subject is measured in the same manner as in triangulation. As illustrated in Fig. 5, the image of the subject O, passes through the windows W and W'' and then is captured as images O' and O'' on the CCD image sensor. The signal at O' is read out by means of a clock and subsequently the number of clocks needed to read the signal at O'' is determined to calculate the angle O'-O-O'' or $\angle \theta$, which then is used to compute the distance of the subject from the camera. Note that the longer the distance, the smaller the angle θ , or the shorter the distance, the larger the angle θ .

1-2. Automatic White Balance Control

The adjustment of white balance poses the most difficult problem in shooting with a color camera. To overcome this difficulty, VC-X1 employs two photodiodes to measure the color temperature of ambient light so as to permit switching automatically between INDOOR (3000°K) and OUTDOOR (5500°K).

Use of the two-diode system helps to ensure "naturalness" especially in outdoor shooting and simplicity of circuit design.

1-3. Auto Iris Control

The VC-X1 is provided with a VR for backlight control (BLC) to permit shooting against the light. The IRIS control knob is normally set at NORMAL position. This causes AGC in the video circuit to operate in the manner described below:

When shooting a dark scene, the iris is fully opened and then if gain is found still insufficient, the gain is increased electrically by means of AGC. Note that the auto-iris is closed with the power OFF, thereby protecting the vidicon.

1-4. Fade-In/Fade-Out

The VC-X1 permits both fade-in and fade-out through one-touche operation. Particularly, the fade-in operation is performed in "reserved" mode, in which the fade-in operation is started as soon as recording is started.

During the Rec. OFF period, the fade-out operation is not accepted.

Further, establishing the STAND-BY mode after fade-out causes a fade-in operation to be performed automatically, thereby making it easier to shoot the next scene.

	Y Signal	Chroma Signal	Picture
1	Normal	Normal	Normal Picture
2	Normal	Reverse	Gradation of brightness is reversed
3	Reverse	Normal	Expression of complementary color
4	Reverse	Reverse	Same picture as that of color negative film

Fig. 6

LED	Disappearance	Switching ON/OFF	Lighting
Red	Rec OFF	When VTR is not set completely in REC Mode.	Rec ON
Green		Slow switching: When White Balance is not Normal. Medium-speed switching: When Auto Iris is not Normal. High-speed switching: When Nega-Posi is not Normal.	
Yellow		Drop in battery voltage (10.8V \pm 0.15V)	(1) Fade In reserved (2) Fade Out in operation

Fig. 7

1-5. Negative/Positive Reversal

In addition to normal pictures, special pictures may be produced through the three possible signal combinations shown in Fig. 6 below:

The mode "4" in Fig. 6 permits a negative color film to be viewed as positive color on the TV monitor.

1-8. Power Zooming

The VC-X1 is capable of continuous zooming from TELE to WIDE with zooming speed changeable in two steps: one for slow zooming and the other (further depression of the button) for fast zooming.

1-9. Boom Microphone

A boom microphone with a window screen (and with an additional window screen in case of a strong wind) is able to reduce significantly the sound of wind recorded.

1-6. LED Display in the Viewfinder

Three LEDs found within the viewfinder provides a means of displaying the following:

1-7. Built-in ND Filter

Use the large-diameter, high-speed lens can often result in the automatic aperture control not being able to cover all conditions under which the camera is used outdoors. In view of this, VC-X1 incorporates an ND-8 filter with a transmissivity of 12.5% so that shooting can be done even under quite-bright-light conditions.

2. EXPLANATION OF CIRCUITRY

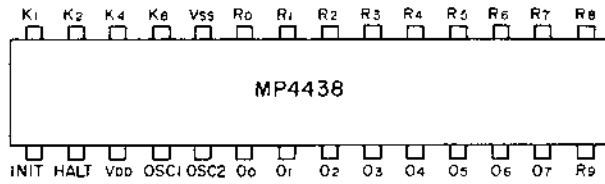

- R₀, R₁, R₂, R₃: Key Scan Clock
- R₄ to R₈: LED Lighting Output
- R₃: Rec trigger
- R₉: Quick Fade Out
- O₀ to O₄: AGC Output (5 bits)
- OSC₁, OSC₂: Self-Oscillation
- HALT: Microcomputer stops at "H". (GND'ed)
- INIT: Initialize

Fig. 8

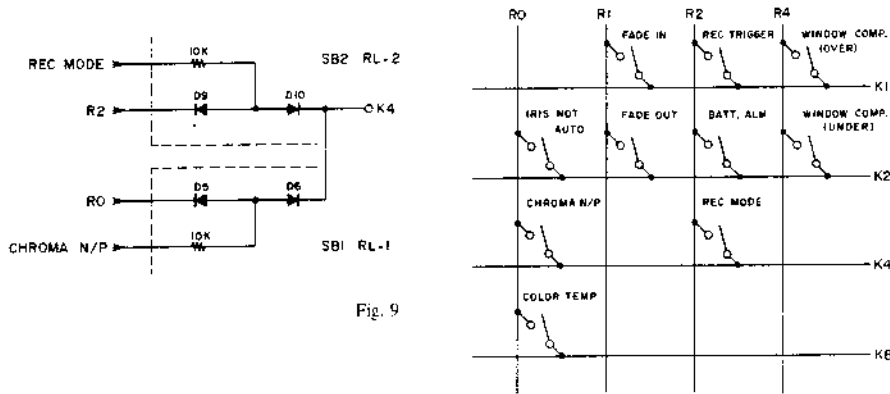

Fig. 9

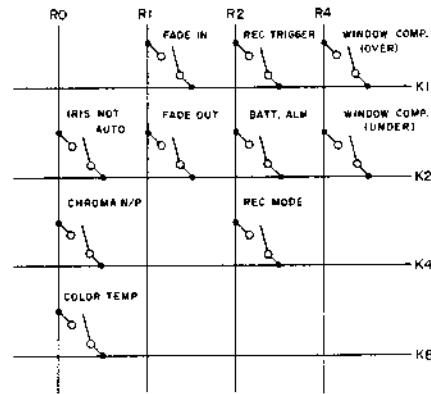

Fig. 10

2-1. Panel P.C Board

The various features of VC-X3 are controlled by the microcomputer MP4438 (IC1).

2-1-1. Diode Matrix Switch

In Fig. 9, when R₀ goes to "positive", D₃ is turned off, permitting the CHROMA N/P pulse to be supplied to K₄. Similarly, the Rec Mode signal is sent to K₄ only when R₂ is at "positive".

2-1-2. Window Comparator

Fig. 11 shows the comparator circuit used to operate the AGC circuit. If the Y signal level (input to the window comparator) is higher than voltage E_A at point A, IC2-1 output goes to "H" level.

On the other hand, if the Y signal level is lower than voltage E_B at point B, then IC2-2 output goes to "H" level.

Thus, output goes to "L" if the input signal E_y is: E_B < E_y < E_A.

The AGC circuit is controlled in such a manner that the output goes to "L".

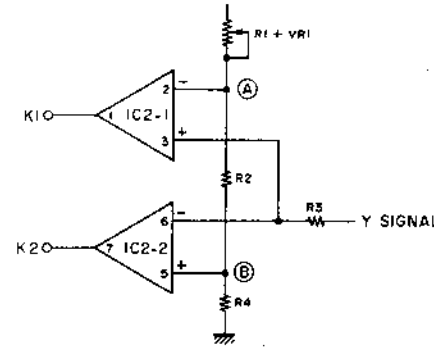

Fig. 11

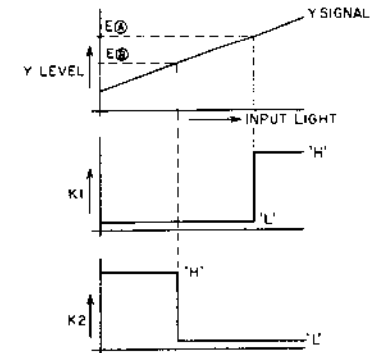

Fig. 12

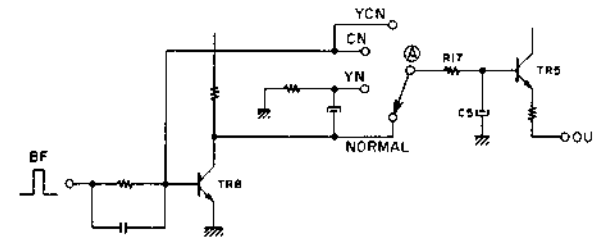

Fig. 13

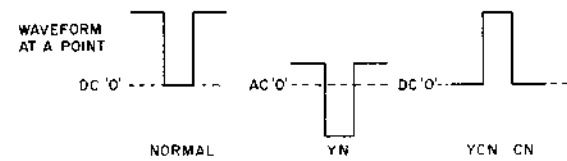

Fig. 14

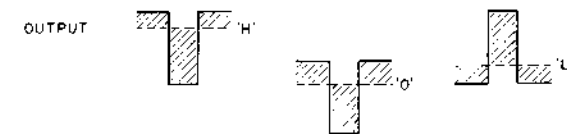

Fig. 15

2-1-3. Chroma Nega/Posi Reversal Circuit

This circuit not only sends information on the position of the NEGA/POSI SW to the microcomputer but also switches BF output between positive and negative.

The waveform of change-over switch output at point A is shown in Fig. 14.

Since the pulse is integrated by R17 and C5, output (at TR5's emitter) goes to "H" with Normal, to

"0" with YN or to "L" with YCN and CN.

This level is read into the microcomputer for display by LED of the position of the NEGA-POSI SW. In addition, the burst flag is also switched by the NEGA-POSI switch. With Normal, it is reversed by TR5 to assume a negative polarity, whereas with Reversal mode, it is output as a pulse of positive polarity without being reversed.

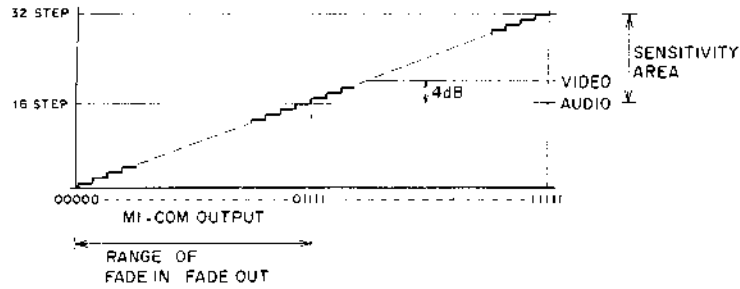

Fig. 16

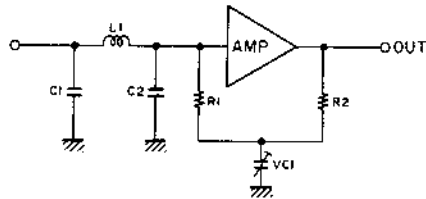

Fig. 17

2-1-4. AGC Output Circuit

Output from the AGC output ports $O_0 - O_4$ of the microcomputer is converted to an analog voltage by the staircase D-A converter circuit.

Further, when the FADE IN or FADE OUT button is depressed, the fade-in or fade-out operation is performed by changing the AGC output voltage as shown in Fig. 16.

TR4 is for discharging C4 to reduce the AGC output to zero for quick fade-out (with fade-in reserved, to start the fade-in operation at the same time that recording is started, it is necessary to start at video out "O").

EF is used for TR6 and TR7 since AGC for the audio circuit requires more current than with the video circuit.

2-2. Pre Amp

Fig. 17 is the block diagram for the pre amp circuit. The amp has a gain of about 55 dB. C1 provides a floating capacity between the lead from the videcon to L1 and the GND. L1 is a resonance coil known as Percival coil. The combined use of this coil and C1 contributes to an about 7 dB improvement in S/N at 4.1 MHz or so. (Note that L1 and C1 make up a 4.1 MHz resonance circuit). VC-X1 is a variable condenser used to correct the frequency characteristic in the low-to mid-ranges.

VR1 and VR2 in the pre amp schematic diagram are intended for adjusting the high-range characteristic.

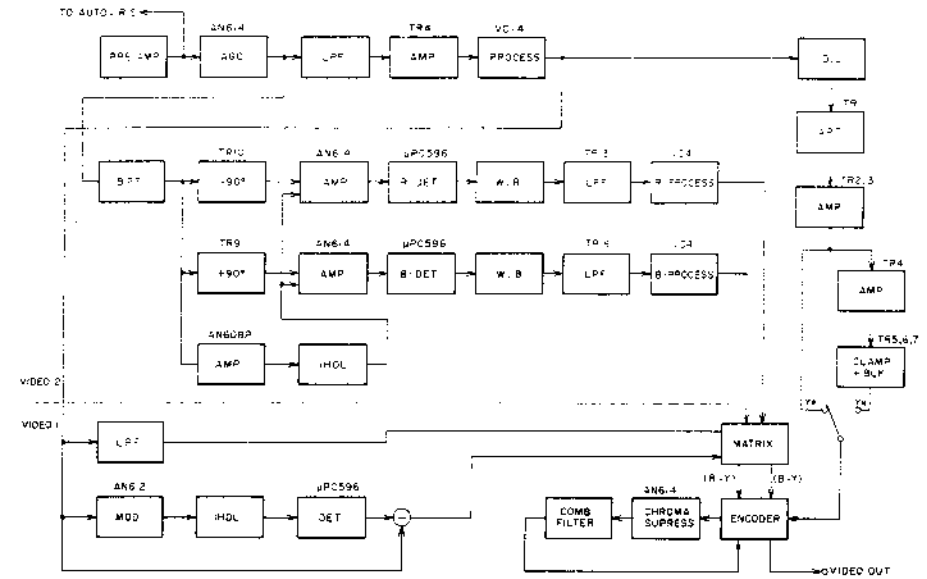

Fig. 18

2-3. Video Amp

The video amp is made up of two P.C Boards: Video (1) and Video (2). Its block diagram is shown in Fig. 18. Output from the pre amp is clamped by TR1 and then supplied to pin ① to IC1 (AN614).

The IC1 is an AGC circuit and its pin ③ accepts, via TR6 (current mirror circuit), the DC voltage that has been level-controlled by VR15.

(Note that this DC voltage is the result of D-A conversion of the 5-bit digital signal from the Panel P.C Board). The AGC amp output branches into two routes. With one route, the amp output is first passed through TR2 (EF) and then through LPF to have its modulated wave component removed before being applied to the Y-process circuit. With the other route, the AGC amp output is passed through BPF to take out the 3.8 MHz component only, which is then supplied to the CHROMA circuit.

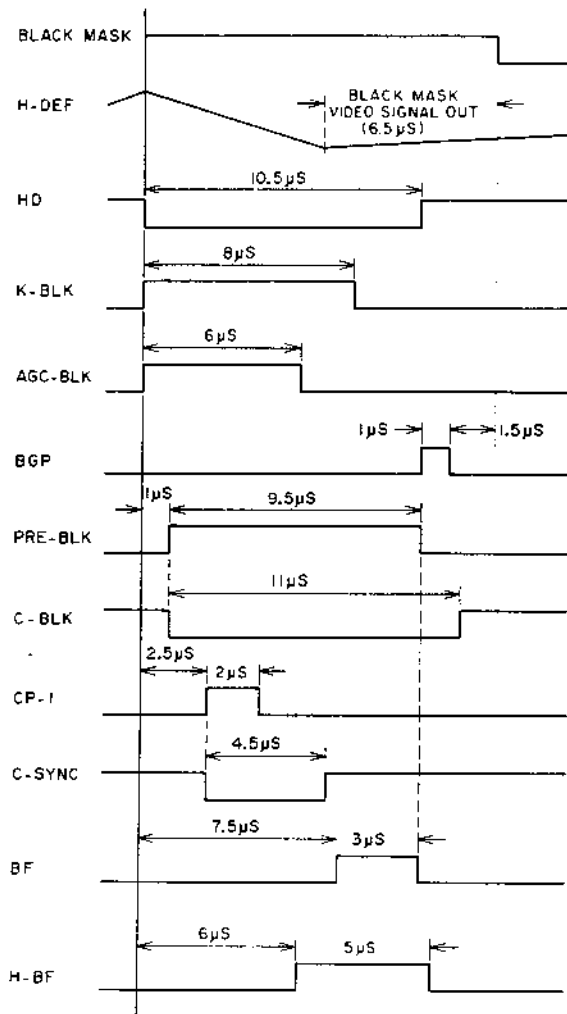

Fig. 19

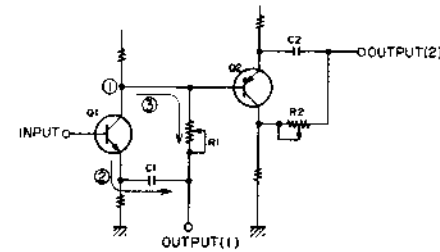

Fig. 20

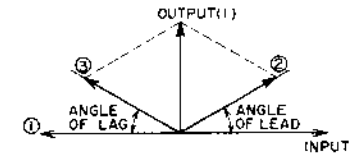

Fig. 21

2.3-1. CHROMA Circuit

1) Color separation circuit

The signal from BPF is phase-shifted $\pm 90^\circ$ by TR9 and TR10.

As can be seen from Fig. 20, when the reverse of the input signal (1) is passed through an integration circuit consisting of R1 and C1, phase lag occurs as illustrated at (3) in Fig. 21. On the other hand, the input signal is passed through the EF circuit and then through a differential circuit consisting of C1 and R1, resulting in the signal phase as illustrated at (2). Thus, the resultant output is as shown in Fig. 21; i.e., the signal that has a phase lead of 90° over the input is obtained. In the similar manner, for output (2), the signal which has a phase lag of 90° with reference to the input is obtained.

When the signals obtained in the manner mentioned above (i.e., those signals whose phase difference from the input signal is $\pm 90^\circ$) and the

IH-delayed input signal are fed into the subtraction circuit, or IC5 (AN614), the R and B signals modulated at 3.8 MHz can be obtained.

Each of these signals is detected by the detector and then passed through the white balance circuit to obtain each of outputs R and B by means of a load resistance (see the White Balance section).

The output is subsequently supplied to LPF, the output of which is then fed into IC7 (VC-4), or the process circuit.

2) White balance circuit

With the VC-X1, the white balance circuit is preceded by the detection circuit for 3.8 MHz-modulated waves (R and B) produced in the color separation circuit. (See Fig. 18). Fig. 22 shows the white balance circuit connections.

Color temperature is controlled by selecting the appropriate load resistance for TR1 and TR2 which must be D1/R1, R2, R3 or R4/TR1. For FL and 3000°K (or 5500°K with B-channel).

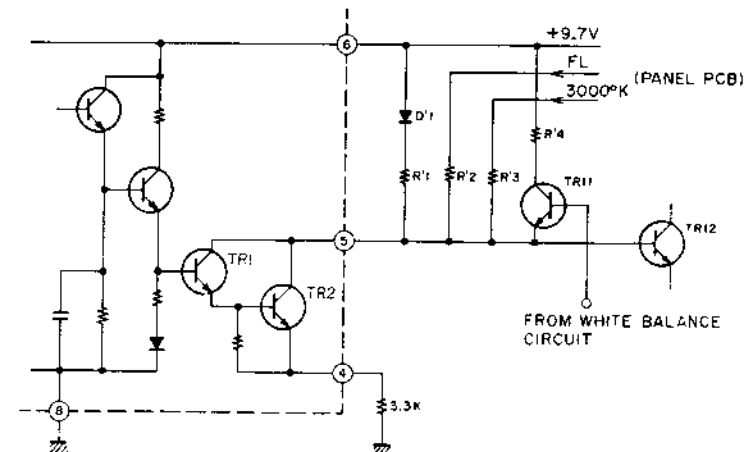

Fig. 22

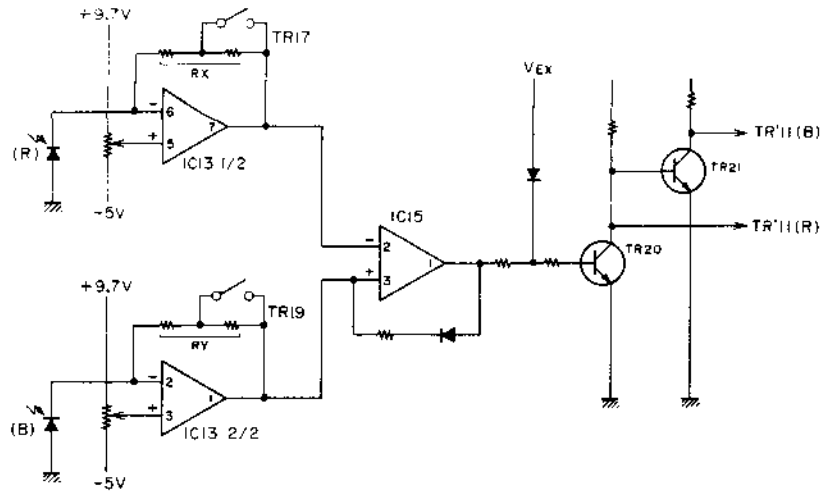

Fig. 23

switching is made by means of the change-over switch on the Panel P.C Board. Also, when this change-over switch is at "AUTO" position, either 3000°K or 5500°K is selected automatically depending on whether TR11 (R-channel) is turned on or TR11' (B-channel) is turned on.

Auto White Balance

The Circuit shown in Fig. 23 is used to switch between TR11 (R-channel) and TR11' (B-channel). The color temperature at the switching point between 3000°K and 5500°K is around 3700°K. With photo-diodes, forward current increases as the amount of incoming light increases. Therefore, with light of 3000°K coming in, a voltage drop by R_x exceeds that by R_y . This causes potential of IC13's ⑥ to drop, which in turn causes IC13's ⑦ to go to "H" level and IC13's ① to go to "L" level. Since IC15's ② is "H" and IC15's ③ is "L", its output (IC15 ④) is "L". This causes TR20 to be turned off and TR21 to be turned on, which in turn turns TR11 on. As a result, the gain of R-channel decreases and white balance is obtained. With IC14, as the amount of incoming light increases, voltage drop by R_x and R_y increases, which in turn causes IC14's ② and ① to decrease and TR17/TR19 to be turned on. As a result, the dynamic range is widened. In the similar manner, if a considerable amount of light is existing, IC14's ① decreases, TR18 is turned on, IC14's ⑥ goes to "L", and IC14's ⑦ goes to "H". This causes Vex to be applied from D1 to turn TR20 on, TR21 off and then TR11 on, thereby switching forcibly to 5500°K. (Note that this applies to AUTO mode only).

3) Process circuit

The process circuit consists of IC7, IC12 and IC8 and its connections are shown in Fig. 24. Fig. 25 is the block diagram of the process circuit. The signal supplied to pin ③ is first passed, through the base graded amp (TR1) and then subjected to gamma correction with voltages made available by R46, R47 and R48 being applied to the bases of TR2, TR3 and TR4, respectively. (See Fig. 25) Subsequently, the signal taken out via EF (TR5) has its black mask portion sampled and held by TR6 (or the blanking portion sampled and held by CP-1 in the case of the red or blue channel), and the output is applied to IC12 (feedback clamp circuit) to keep constant the DC level of signals delivered from the base graded amp (TR1). The feature of this circuit is that the γ point can be shifted by changing the DC level. If the level of the black mask portion is raised due to change in temperature, dark current (or the DC fluctuation of the black portion in the case of R-ch or B-ch) increases. This causes potential at IC12's pin ⑥ to increase, and the level at pin ⑦ to be lowered, which in turn lowers the DC level of both emitter and collector (TR1), thereby correcting the dark current. In addition, if the DC level is varied by VR7 as indicated by ①, ② and ③ in Fig. 26, the γ point will be shifted as illustrated. Note that at ①, a slight increase in level causes " γ_1 " to operate immediately, whereas at ②, only a significant increase in level causes " γ_1 " to operate. The γ -corrected signal is subjected to BLK in TR7 and then to SET-UP before being taken out as VC-4 output.

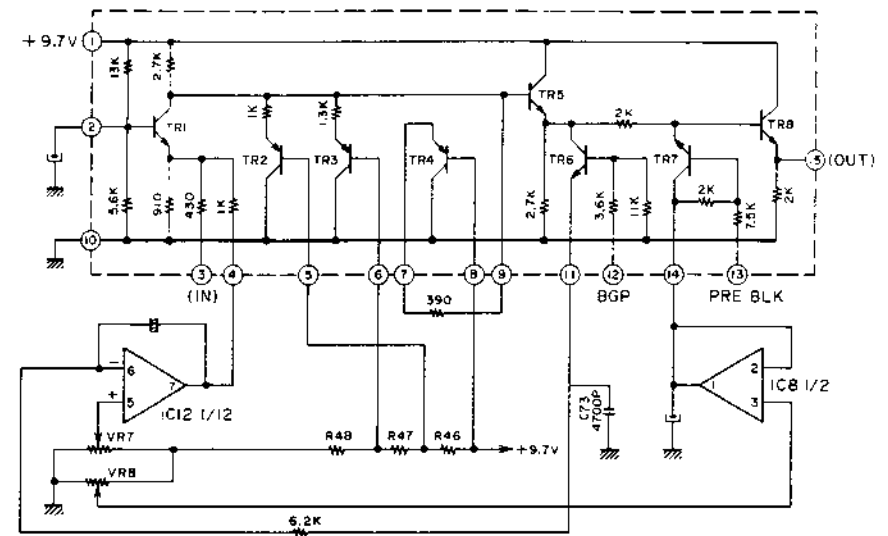

Fig. 24

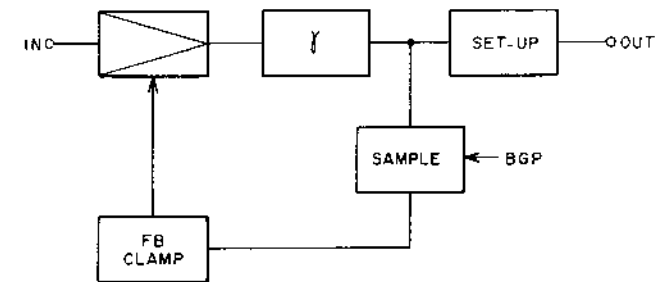

Fig. 25

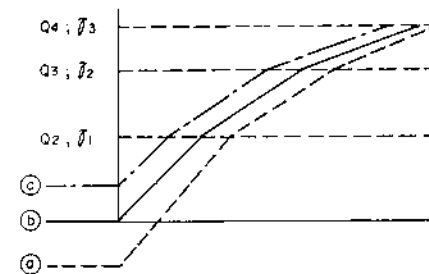

Fig. 26

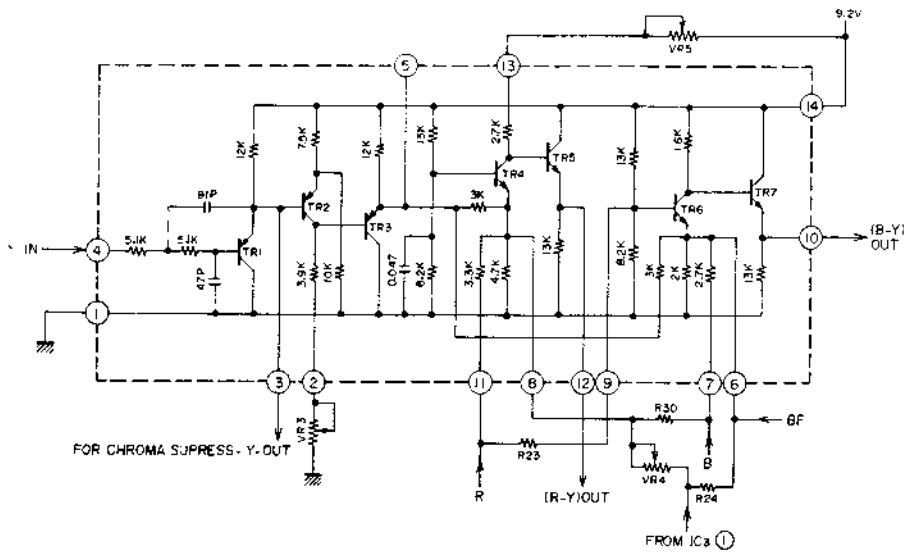

Fig. 27

4) Matrix circuit

The output from the process circuit on the video (2) P.C Board is supplied to the matrix circuit in IC4 (VC-1) on the Video (1) P.C Board. The Y-signal is also supplied to IC4's pin 4 from the Video (2) P.C Board, and (B-Y) and (R-Y) are obtained as output from IC4's pin 10 and pin 12 respectively. In addition, the correction signal from the vertical correlation circuit is also supplied to IC4's pins 6 and 5 to adjust vertical correlation. The TR1 circuit acts as an active low-pass filter.

5) Encoder circuit

The output (B-Y) from IC4 pin 10 and output (R-Y) from IC4 pin 12 are supplied to IC5 pin 12 and pin 10 respectively. The Y-signal that has undergone Nega/Posi selection on the Panel P.C Board is supplied to IC5 pin 9. In addition, the subcarrier is supplied to IC5 pin 15 and pin 16 and, after double balanced modulation, is taken out as output from IC5 pin 8. As shown in Fig. 28, IC5 incorporates a circuit whose purpose is to take out the (R-Y) + (B-Y) output from pin 3 and return it to pin 5 via the CHROMA SUPPRESS circuit. This permits chroma signals to be removed if the amount of light is less or more than specified, resulting in the B/W signal being produced.

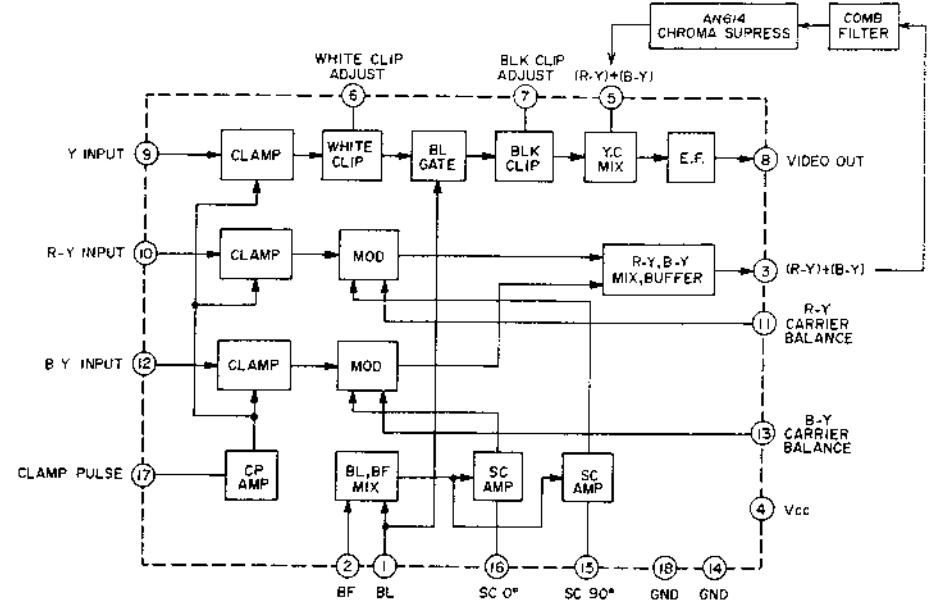

Fig. 28

6) Chroma suppressor

This circuit consists of IC6 and TRs 9-13. IC6 is controlled through the level of the Y signal supplied to IC4: the (R-Y) + (B-Y) signal is cut off if the amount of light is not at a certain level. If the difference between the base potential of TR10 (as set by VR9) and the emitter potential (V_H) of TR10 becomes 0.6V or less as the Y signal level goes up because of increase in the amount of incoming light, then TR10 is turned off, and the voltage applied to IC6 pin 5 increases. Since TR13 is also off at this time, voltage at IC6 pin 5 is equal to potential at IC6 pin 1. On the other hand, as the Y-signal level goes down past a certain level, the difference between TR12's base potential and emitter potential becomes more than 0.6V, causing TR12 to be turned on. This also causes TR10 to be turned on, resulting in the potential at IC6 pin 5 being equal to that at IC6 pin 1. Since the output of IC6 (AN614) is "0" when the potential at pin 5 is equal to that at pin 1, the chroma signal will be cut off if the amount of incoming light is not at the specified level, as discussed above.

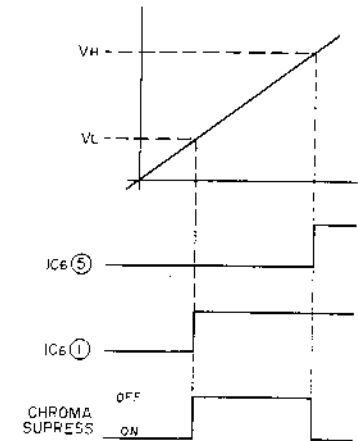

Fig. 29

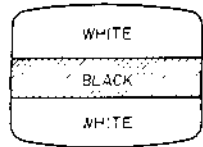

Fig. 30

7) Vertical color error correction circuit

When the picture shown in Fig. 30 is displayed, the signal pattern involved in the white/black interface is as illustrated in Fig. 31.

If the signal pattern mentioned above is delayed by 1H, a different signal pattern shown in ② will be produced.

Subtracting ② from ① will result in the signal pattern illustrated in ③ above, which is then added to ① to adjust vertical color errors.

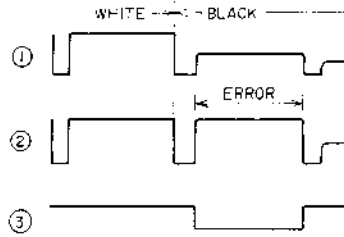

Fig. 31

2-3-2. Y-Signal Circuit

The signal that has passed through the AGC circuit on the Video (2) P.C Board is then routed through EF (TR2) and then through FL1 (LPF : 3 MHz or lower) where the signal has its modulated chroma component removed (i.e., the Y-signal is passed through the process circuit of VC-4 and then taken out as the AGC signal from J15 ② to be delivered to the Panel P.C Board.

The Y-signal is also supplied to the Video (1) P.C Board as "Yout".

1) Aperture circuit

As illustrated in Fig. 32, the waveform ② is obtained through a differential circuit with L and differential circuit with C3.

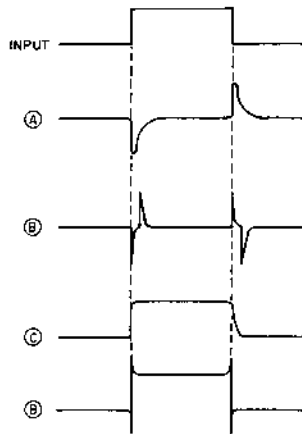
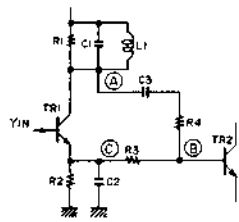

Fig. 32

2) Y Nega/Posi circuit

The Posi signal is conveyed to the N/P change-over switch on the Panel P.C Board via TR2 and TR3. The Nega signal is produced by TRs 4-6.

With only the inversion circuit involved, there will be no output if B is clamped by CP as illustrated in Fig. 34. The disappearance of the signal can be avoided by clamping with D1 after introduction of HD with TR4.

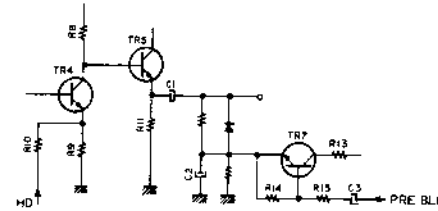

Fig. 33

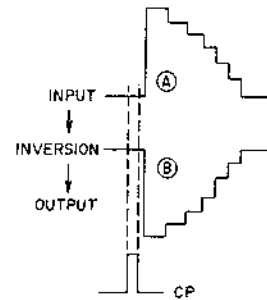

Fig. 34

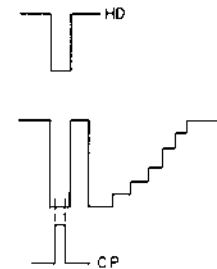

Fig. 35

2-4. Auto Iris

With the auto iris circuit, the pre-amp output is first passed through EF (TR22), then clamped by TR23, and finally integrated by R82/C42.

Subsequently, after impedance conversion, the iris motor is driven by IC16. The drive coil is one that is located between P12's 3 and 4, while the dump coil is one that is placed between P12's 1 and 2. The iris speed is controlled by taking out acceleration output from the dump coil and then supplying it to IC16 6.

In addition, balance current is always flowing through the drive coil since the iris is always subjected to a force which tends to close it.

Thus, turning off the power causes the iris to be closed automatically, thereby providing a means of protecting the vidicon.

2-5. Power Zoom

The power zoom circuit is driven by IC17.

Depressing the tact switch slightly causes Common, A and C to be connected (first step).

Further depression of the switch causes all of Common, A, B and C to be brought into contact (Second step).

Thus, in the first step with the Wide Switch, voltage EW₁ which is obtained by dividing 4.7V by R95 and R94 is applied to IC17 ⑥. When the switch is further depressed, voltage EW₂ which is obtained by dividing 4.7V by R95//R96 and R94 is applied.

Since EW₁ < EW₂, output voltage in the second step is lower than that in the first step, making zooming possible in the second step.

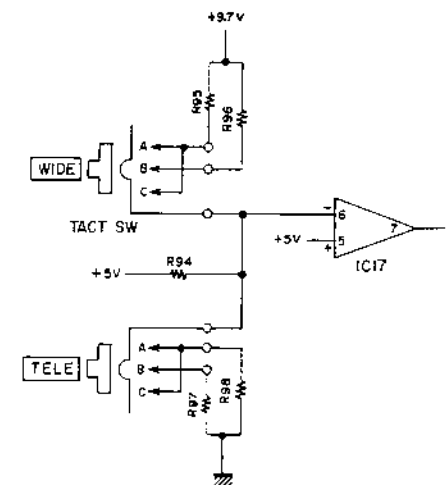



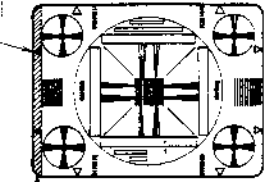

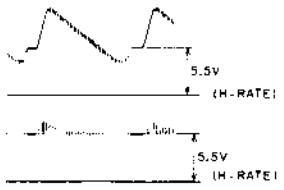
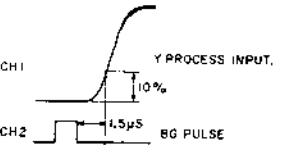
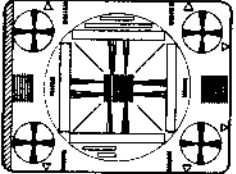
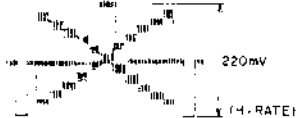
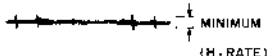
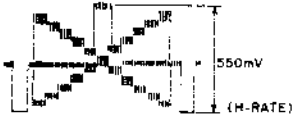
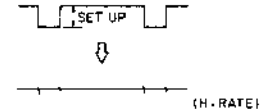



Fig. 36

Step	Adjustment Item	Pattern	Iris	Test Point	Adjustment Parts	Result & Remarks
1	Setting					Set each switch to proper position Nego/Post switch NORMAL White Balance switch 3000°K AF switch MANUAL ND filter OFF
2	DC Power Supply			P5 (H & D PCB)	VR17 (H & D PCB)	Increase the voltage by steps and set at +9.7V.
3	Beam	White	Open	Monitor Screen	VR4 (H & D PCB)	Set VR4 so that the picture is produced on the screen.
4	Checking for dirt	White	Open	Monitor Screen		Upon replacement of the vidicon, make certain that there is no adhering dirt or dust.
5	Target (After 20 ~ 30 minutes of ageing)		Close	TP1 (Video 2 PCB)	VR5 (H & D PCB)	 Adjust so that the waveform has a height of 10 mV (at 20°C ± 5°C).
6	Beam	Bright object in portion of picture	Open	TP1 (Video 2 PCB)	VR4 (H & D PCB)	 Include a bright object in a portion of the picture and adjust so that the saturation level of the output waveform is 600 mV.
7	Turning Tube	White	F5.6	TP1 (Video 2 PCB)	Vidicon (Loosen retaining screws)	 Turn the vidicon so that the rising portion of the waveform appears as a single line. (Caution: high tension is involved).
8	Horizontal Adjustment	Resolution	F5.6	Monitor Screen	Deflecting coil (Loosen 4 retaining screws)	Loosen 4 screws retaining the deflecting coil and turn the deflecting coil so that the picture is made level.



Step	Adjustment Item	Pattern	Iris	Test Point	Adjustment Point	Result & Remarks
9	Size	Resolution	F5.6	Monitor Screen	VR14 (V Size) L3 (H Size) (H & D PCB)	 Rotate the zoom ring to display the resolution pattern as large as possible on the monitor screen. Adjust VR14 and L3 so that wedges on each side of the pattern coincides with the boundary of the monitor screen.
10	Ageing		Close			Allow about one hour of ageing (at 20°C ± 5°C).
11	Readjust steps 5 and 6 (target and beam).					
12	Focus	White	F5.6	TP1 (Video 2 PCB)	VR3 (H & D PCB)	 Adjust so that the modulated wave in the waveform becomes maximum.
13	Back Focus			Monitor Screen	Back Focus Adjustment Screw	<ol style="list-style-type: none"> 1. Set the focus ring to "∞", zoom to WIDE, and then shoot a distant object. 2. Loosen the fixation screw and focus by means of the adjusting screw. 3. Zoom to TELE and focus by means of the focus ring. 4. Zoom once again to WIDE and adjust to get the right focus by means of the adjusting screw. 5. Repeat the above steps 1 through 4 until the object focused upon zooming to WIDE is found to be still in focus upon zooming to TELE. After this, tighten the fixation screw.

Step	Adjustment Item	Pattern	Iris	Test Point	Adjustment Parts	Result & Remarks
14	H Deflection	White	F5.6		L3 (H Size) VR3 (H Linearity) VR9 (H Linearity) (H & D PCB)	 <p>Connect linearity checker input to TP1 (Video 2 PCB) and its output to oscilloscope.</p> <p>Obtain an average output of 5.5V by means of L3. Adjust VR2 and VR9 alternately to flatten the waveform. Repeat the adjustment until the satisfactory results are obtained.</p>
15	H Center	White	F5.6		CH1: TP3 (Video 2 PCB) CH2: IC7 ④ (Video 1 PCB) VR1 (H & D PCB)	 <p>Adjust VR1 so that the interval between the rising portion of the Y-process input waveform and the BG pulse is 1.5 µsec.</p>
16	V Deflection	Resolution	F5.6	Monitor Screen	VR14 (V-Size) VR15 (V Linearity) (H & D PCB)	 <ol style="list-style-type: none"> Zoom up so that the right-hand wedges for H-direction are as near to the edge of the monitor screen as possible. Note that the left-hand wedges must be hidden by the black mask. Adjust by means of VR14 so that the wedges for V-direction are as near to the edges of the monitor screen as possible. Adjust VR15 so that the circles in the corners are free of distortions.

Step	Adjustment Item	Pattern	Iris	Test Point	Adjustment Parts	Result & Remarks
17	V Center	Resolution	F5.6	Monitor Screen	VR16 (H & D PCB)	Zoom to TELE and adjust the camera position so that the center of the pattern is at the center of the monitor screen. Zoom to WIDE and adjust VR so that the center of the pattern coincides with the center of the monitor screen.
18	IRIS Set	Gray Scale	Click	TP1 Video 2 PCB)	VR3 (Panel PCB)	 <p>Adjust VR3 so that the white peak (center) stands at 220 mV.</p>
19	Fade Out	Gray Scale	Click	TP3 (Video 2 PCB)	VR17 (Video 2 PCB)	<p>Short the Rec socket P18 (Panel PCB) with a screwdriver, etc. Press the fade-out SW to verify that the picture darkens.</p>  <p>Adjust VR17 so that the waveform is minimized. Press the fade-in SW to verify that the picture brightens.</p>
20	AGC (1)	Gray Scale	Release iris from "click" position and turn it clockwise slightly.	TP3 (Video 2 PCB)	VR15 (Video 2 PCB)	 <p>Adjust VR15 so that the white peak (center) stands at 550 mV.</p>
21	AGC (2)	Gray Scale	Click	TP3 (Video 2 PCB)	VR1 (Panel PCB)	Put the iris back to the "click" position and adjust VR1 so that the white peak (center) stands at 550 mV.
22	AGC (3)	Gray Scale	Close	TP7 (Video 2 PCB)	VR8 (Video 2 PCB)	 <p>Adjust VR8 so that "set-up" becomes zero.</p>

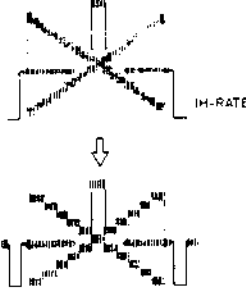
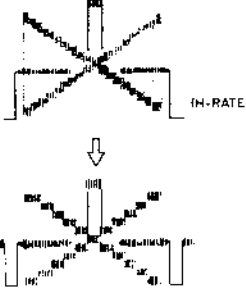
Step	Adjustment Item	Pattern	Iris	Test Point	Adjustment Parts	Result & Remarks
23	Alignment	White	Click	TP1 TP3 TP2 (H & D PCB)	VR3 (Focus) VR7 (R-SAW) VR11 (R-PARA) VR8 (B-SAW) VR12 (B-PARA) (H & D PCB)	Set up a state in which Dynamic Focus/Shading is cancelled.
				Monitor Screen	VR3 (H & D PCB) Alignment ring	Adjust the alignment ring and Focus (VR3) alternately so that the optimum shading is obtained.
24	Focus	White	Click	Monitor Screen	VR3 (Focus) VR10 (H-PARA) VR6 (H-SAW) VR13 (V-SAW) (H & D PCB)	<ol style="list-style-type: none"> 1. Reduce the green portion of the picture by means of VR3. 2. Minimize unevenness in color at the sides and around the center by means of VR10. 3. Minimize unevenness in color at the right and left by means of VR6. 4. Minimize unevenness in color at the top and bottom portions of the screen by means of VR13. 5. Minimize unevenness in color around the center of the screen by means of VR3. 6. For unevenness in color not mentioned above, readjust alignment.
25	Readjust H-Center (Step 15).					
26	Y-Signal	Gray Scale	Manual	TP7 (Video 2 PCB)	VR7 (Video 2 PCB)	 <p>Set the Iris Volume (VR4) so that the white peak (center) stands at 800 mV. Also, adjust VR7 so that the staircase wave is made linear.</p>
			Close	TP7 (Video 2 PCB)	TP7 (Video 2 PCB)	Verify that "set-up" is zero. If not zero, perform step 22 again.

Step	Adjustment Item	Pattern	Iris	Test Point	Adjustment Parts	Result & Remarks
27	B-Signal	Gray Scale	Click	TP6 (Video 2 PCB)	VR1 (B-Phase) VR5 (B-Balance) (Video 2 PCB)	 <p>Adjust VR1 and VR5 alternately so that a satisfactory staircase waveform is obtained.</p>
				TP6 (Video 1 PCB)	VR9 (Gain) (Video 2 PCB)	Adjust VR9 so that the white peak (center) stands at 800 mV.
28	R-Signal	Gray Scale	Click	TP5 (Video 2 PCB)	VR2 (R-Phase) VR3 (R-Balance) (Video 2 PCB)	 <p>Adjust VR2 and VR3 alternately so that a satisfactory staircase waveform can be obtained.</p>
				TP2 (Video 1 PCB)	VR4 (Gain) (Video 2 PCB)	Adjust VR4 so that the white peak (center) stands at 800 mV.

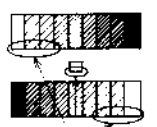
Step	Adjustment Item	Pattern	Iris	Test Point	Adjustment Parts	Result & Remarks
29	White Balance (1-1)	Gray Scale	Click	CH1: TP7 (Video 2 PCB) CH2: TP6 (Video 1 PCB)	VR6 (Video 2 PCB) VR9 (Video 2 PCB) VR10 (Video 2 PCB) VR12 (Video 1 PCB) VR8 (H & D PCB)	 <p>VR6 B-Gain: Magnitude of entire waveform VR9 B-γ: Lower portion of staircase wave VR10 B-Setup: "Set-up" portion VR12 B-Parabola: Linearity of staircase wave VR8 B-Saw tooth: Longitudinal slope of staircase wave Adjust VRs listed above so that the Y-process output waveform (CH1) and B-process output waveform (CH2) are made identical.</p>
30	White Balance (1-2)	Gray Scale	Click	CH1: TP7 (Video 2 PCB) CH2: TP2 (Video 1 PCB)	VR4 (Video 1 PCB) VR11 (Video 2 PCB) VR12 (Video 2 PCB) VR7 (H & D PCB)	<p>VR4 R-Gain VR11 R-γ VR12 R-Setup VR7 R-Parabola VR7 R-Saw tooth As in step 29, adjust VRs listed above so that the Y-process output waveform (CH1) and R-process output waveform (CH2) are made identical.</p>
31	Vertical Error Correction	Gray Scale	Click	TP1 (Video 1 PCB)	VR2 (Video 1 PCB)	 <p>Adjust VR2 so that the output waveform is reduced to zero.</p>
				Monitor Screen	VR4 (Video 1 PCB)	 <p>WATCH THIS STRAIGHT PART</p> <p>Adjust VR4 so that there are no colored shades produced in the straight portions of the gray scale indicated above.</p>

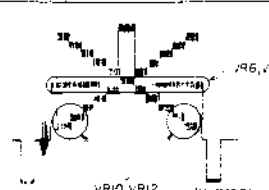
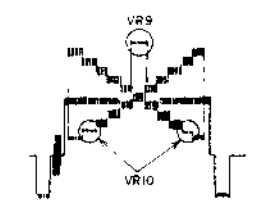
Step	Adjustment Item	Pattern	Iris	Test Point	Adjustment Parts	Result & Remarks
32	White Balance (2)	Gray Scale	Click	TP8 (Video 1 PCB)	VR10 (B-set up) VR12 (R-set up) VR6 (B-Gain) VR4 (R-Gain) (Video 2 PCB)	 <p>Adjust VR10 and VR12 so that the carriers in the lower portions of the staircase wave are minimized. Also, adjust VR6 and VR4 so that the carrier around the middle of the staircase wave is minimized.</p>
33	Chroma Suppressor	Gray Scale	Click	TP8 (Video 1 PCB)	VR10 (Video 1 PCB)	 <p>Adjust VR10 so that the second lowest carrier of the staircase wave is minimized.</p>
			Open	TP8 (Video 1 PCB)	VR9 (Video 1 PCB)	Adjust VR9 so that a little of the carrier at the white peak (center) is left, as shown above. Note that minimizing the carrier will result in discontinuity of color.
34	Assembling	Before assembling, disconnect power supply and discharge high voltage by shorting between terminals 5 - 8 of the Socket PCB and the chassis with the use of a 1Mohm resistance.				
35	White Balance (2)	Readjust white balance (2) (step 32).				
36	Ageing	Close the iris and allow about five hours of ageing. (This is required only when the vidicon is replaced.)				
37	White Balance (2)	Readjust white balance (2) (step 32). (This is required only when the vidicon is replaced.)				
38	Confirming	Display the white pattern and verify that there is no unevenness in color or abnormal coloration. If a vectorscope is available, make check on carrier balance.				

3. ADJUSTING THE EVF BLOCK

To adjust the EVF Block, it is necessary to connect it to the camera body that has been thoroughly adjusted.

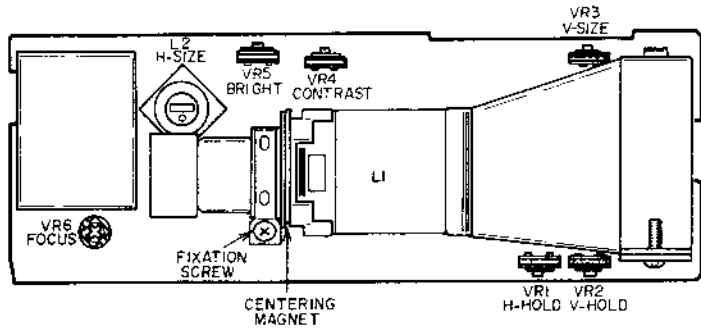

Fig. 45 EVF Block

Step	Adjustment Item	Pattern	Test Point	Adjustment Point	Result & Remarks
1	H-Hold	Resolution	EVF Screen	VR1 (H-Hold)	Fix at point at which the picture synchronizes into one picture.
2	V-Hold	Resolution	EVF Screen	VR2 (V-Hold)	Fix at position at which the picture is stationary.
3	CRT Yoke	Resolution	Monitor Screen EVF Screen	L1 (DY)	<p>Set the camera so that the wedges found in the upper and lower portions of the pattern align with the boundary of the monitor screen. Then, turn the zoom ring to bring the wedges onto the boundary of the EVF screen, at which time the deflecting yoke must be adjusted so that a picture slope of 0 ± 0.8 mm is obtained.</p>

Step	Adjustment Item	Pattern	Test Point	Adjustment Point	Result & Remarks
4	H Deflection Size & V Deflection Size	Resolution	Monitor Screen & EVF Screen	L2 (H-Size) VR3 (V-Size)	<ol style="list-style-type: none"> Set the camera so that the wedges under each side of the pattern align with the boundary of the monitor screen. It is also necessary to make the following adjustment so that $85\% \pm 5\%$ of the resolution pattern is displayed on the EVF screen. Adjust L2 (H-deflection size) so that the pattern displayed is as shown in (b) above. Adjust VR3 (V-deflection size) so that the circles within the resolution pattern are free of distortions. Verify that the picture displayed on the EVF screen is $85\% \pm 5\%$ of the picture displayed on the monitor screen.

Step	Adjustment Item	Pattern	Test Point	Adjustment Point	Result & Remarks
5	Contrast	Gray Scale	EVF Screen	VR4	<p>Adjust VR4 so that No. 9 and No. 10 of Gray Scale chart attached to the resolution pattern can be distinguished.</p>
6	Brightness	Gray Scale	EVF Screen	VR5	Adjust VR5 to such a brightness that facilitates focusing.
7	Focus	Resolution	EVF Screen	VR6	Adjust VR6 so that the highest resolution can be obtained; verify that the resolution obtained is at least 330 lines (Horizontal) by 270 lines (Vertical).
8	Centering	Resolution	Monitor Screen & EVF Screen	Centering Magnet	Adjust centering magnet so that the center of the resolution pattern reflected on monitor screen comes to the center of screen.

VII. CLASSIFICATION OF VARIOUS P.C BOARDS

1. P.C BOARD TITLES AND IDENTIFICATION NUMBERS

P.C Board Title	P.C Board Number
Video (1) P.C Board	V3003A5010
Video (2) P.C Board	V3003A5011
AW P.C Board	V3003A5012
Pre Amp P.C Board	V3003A5013
H & D P.C Board	V3003B5030
Socket P.C Board	V3003B5031
EVF P.C Board	V3003C5040
Panel P.C Board	V3003C5021
Rec P.C Board	V3003D5022

2. COMPOSITION OF VARIOUS P.C BOARDS

1) VIDEO (1) P.C BOARD V3003A5010 (2ED)

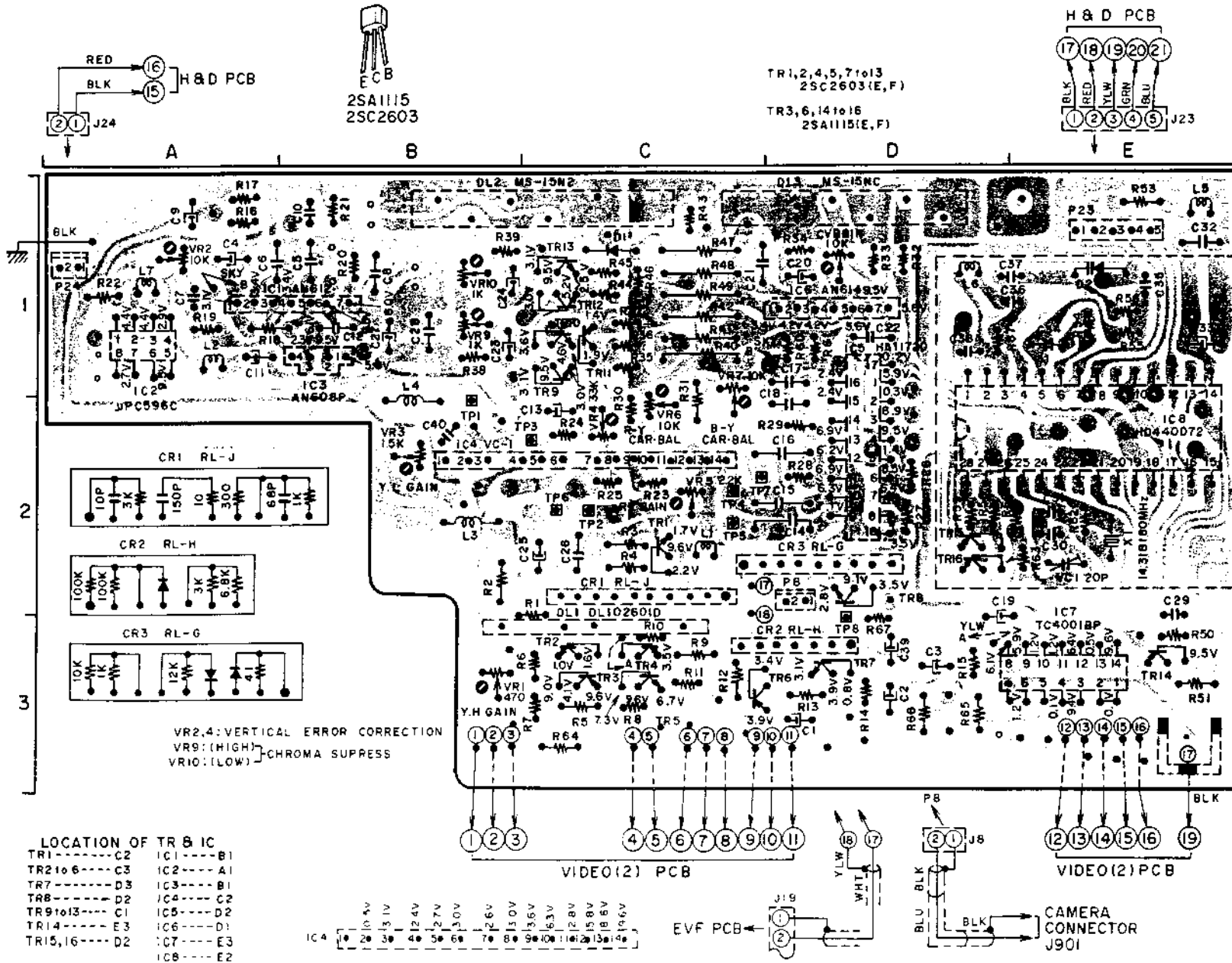

2) VIDEO (2) P.C BOARD V3003A5011 (3ED) and AW P.C BOARD V3003A5012

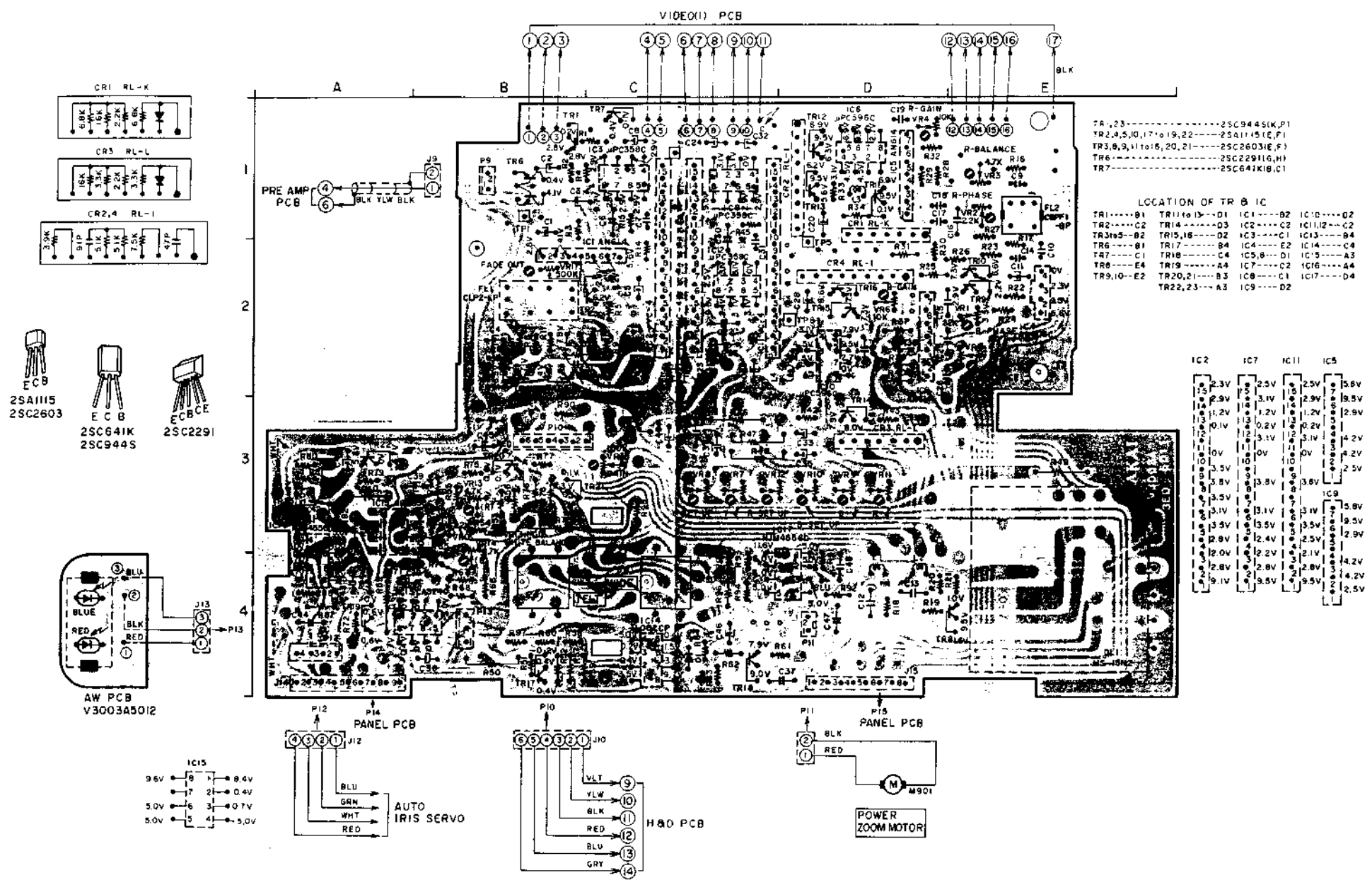

TR1,23-----2SC944S(K,P1)
 TR2,4,5,10,17to19,22-----2SA1115(E,F1)
 TR3,6,9,11to16,20,21-----2SC2603(E,F)
 TR6-----2SC2291(L,G,H)
 TR7-----2SC641K16,C1

LOCATION OF TR & IC
 TR1----B1 TR11to13---D1 IC1----B2 IC10----D2
 TR2----C2 TR14----D3 IC2----C2 IC11to12---C2
 TR3to5---B2 TR15,16---D2 IC3----C1 IC13----B4
 TR6----B1 TR17----B4 IC4----E2 IC14----C4
 TR7----C1 TR18----C4 IC5,8----D1 IC15----A3
 TR8----E4 TR19----A4 IC7----C2 IC16----A4
 TR9,10---E2 TR20,21---B3 IC8----C1 IC17----D4
 TR22,23---A3 IC9----D2

IC2	IC7	IC11	IC5	
1	2.3V	2.5V	2.5V	5.8V
2	2.9V	3.1V	2.9V	3.5V
3	1.2V	1.2V	1.2V	2.9V
4	0.1V	0.2V	0.2V	4.2V
5	0V	0V	0V	4.2V
6	3.5V	3.1V	3.1V	2.5V
7	3.8V	3.8V	3.8V	
8	3.5V	3.5V	3.5V	IC9
9	3.1V	3.1V	3.1V	5.8V
10	3.5V	3.5V	3.5V	3.5V
11	2.8V	2.4V	2.5V	2.9V
12	2.0V	2.2V	2.1V	4.2V
13	2.8V	2.8V	2.8V	4.2V
14	3.1V	3.5V	3.5V	2.5V

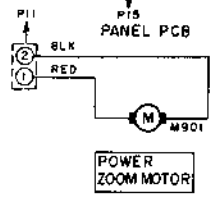
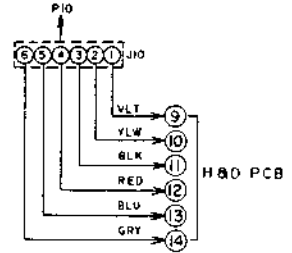
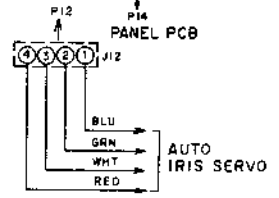
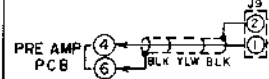
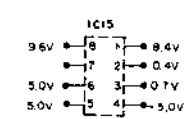
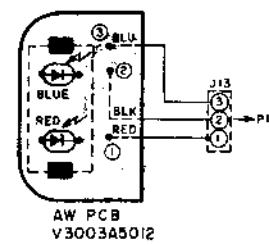
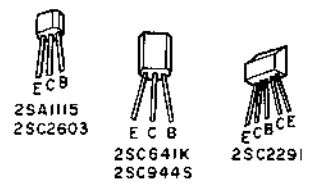
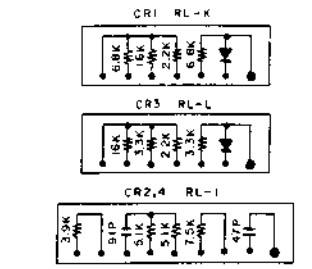

3) H & D P.C BOARD V3003B5030 and SOCKET P.C BOARD V3003B5031

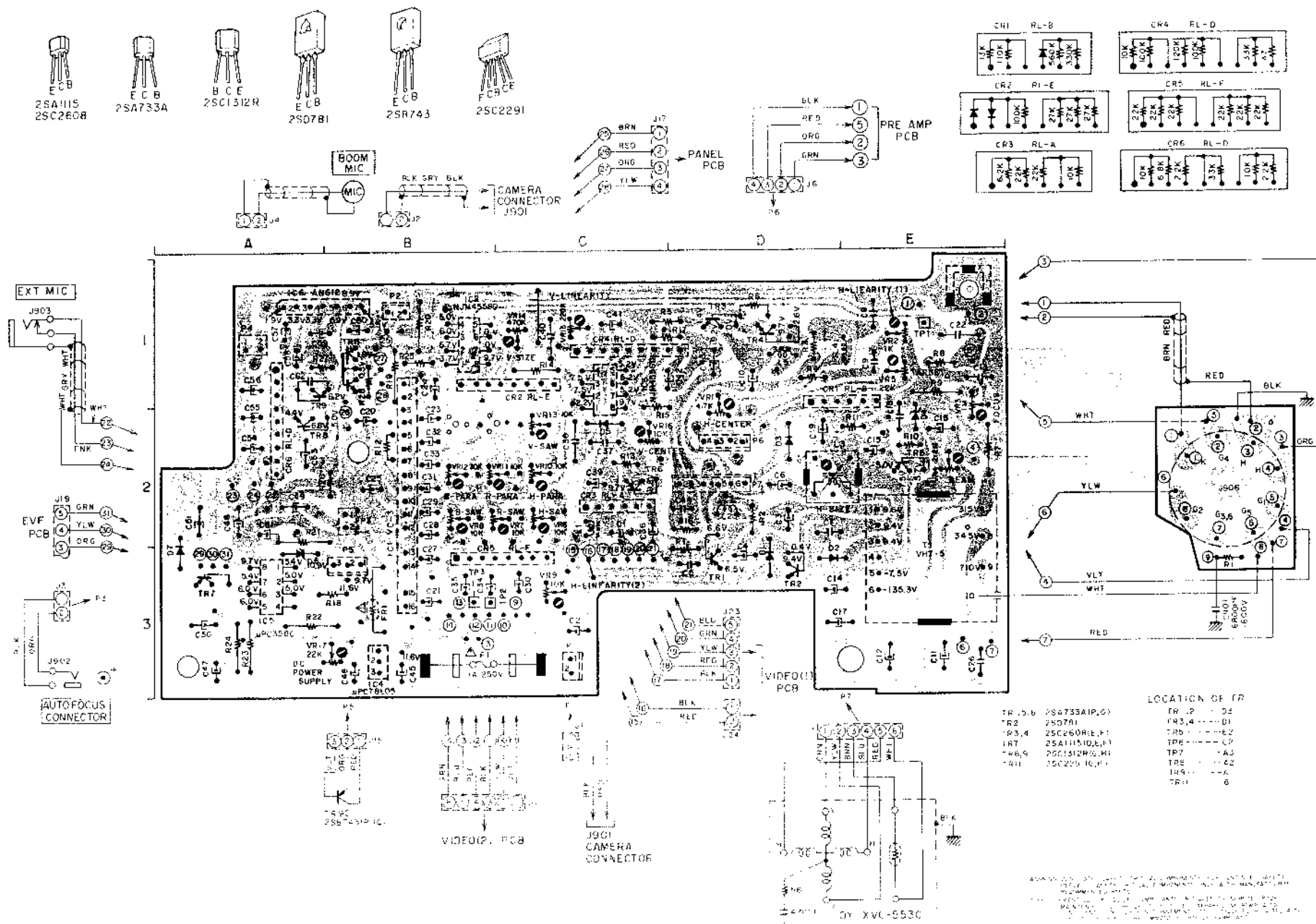

5) PRE AMP P.C BOARD V3003A5013

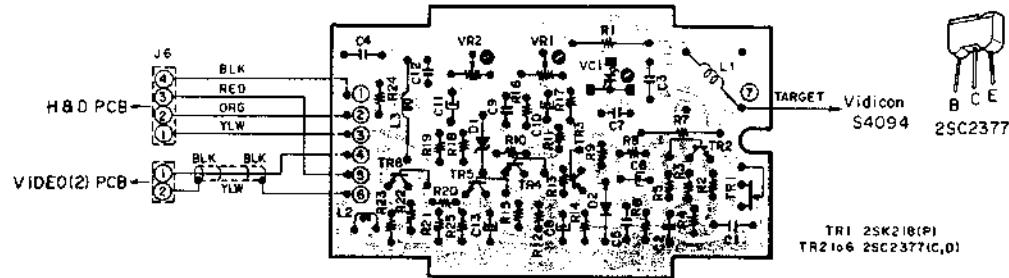

6) EVF P.C BOARD V3003C5040

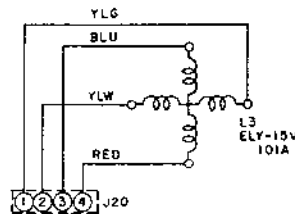
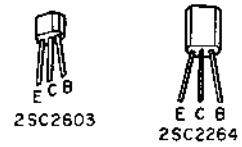

WARNING: THIS CHASSIS CONTAINS COMPONENTS CRITICAL FOR X-RADIATION SAFETY. FOR CONTINUED X-RADIATION SAFETY PLEASE REPLACE WITH A COMPONENT OF THE SAME TYPE.

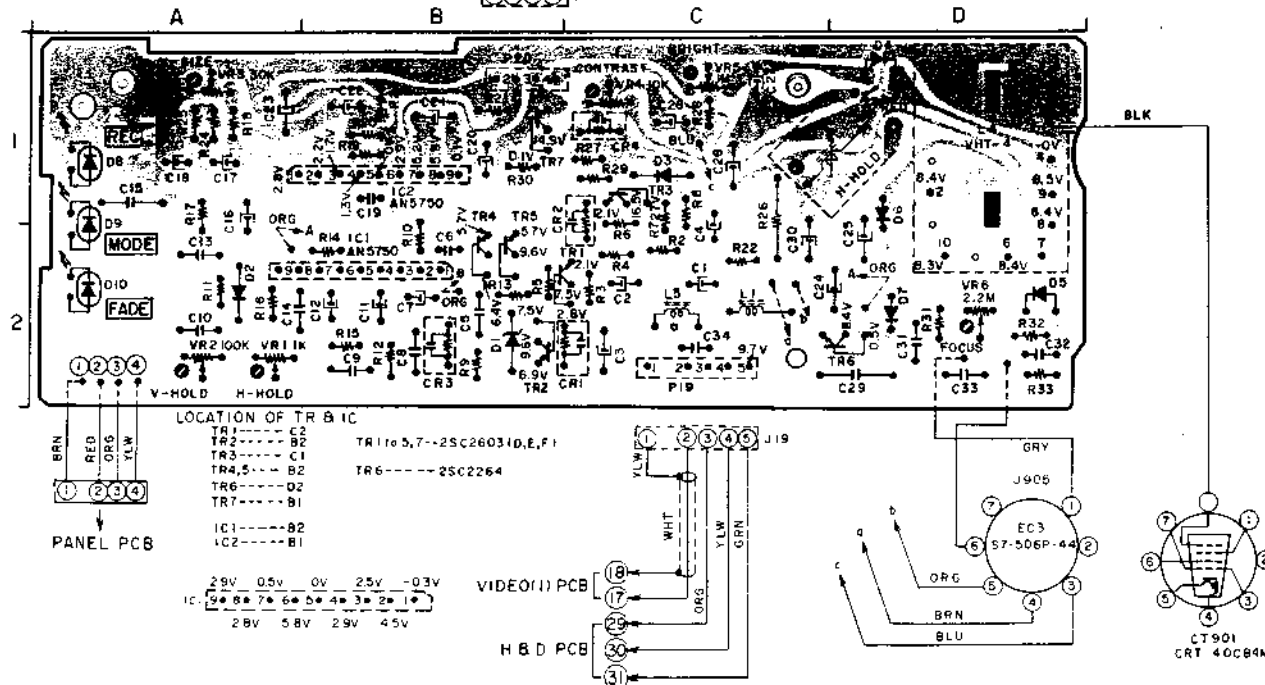

SECTION 2

PARTS LIST

TABLE OF CONTENTS

1. RECOMMENDED SPARE PARTS	49
2. VIDEO (1) P.C BOARD BLOCK	49
3. VIDEO (2) P.C BOARD BLOCK	50
4. H & D P.C BOARD BLOCK	51
5. PRE AMP P.C BOARD BLOCK	51
6. PANEL P.C BOARD BLOCK	51
7. EVF P.C BOARD BLOCK	52
8. REC P.C BOARD BLOCK	52
9. ASSEMBLY BLOCK	53
10. FINAL ASSEMBLY BLOCK	54
INDEX	55

Resistor and Capacitor which is not listed in this parts list, please refer to COMMON LIST FOR SERVICE PARTS.

HOW TO USE THIS PARTS LIST

1. This parts list is compiled by various individual blocks based on assembly process.
2. When ordering parts, please describe parts number, serial number, and model number in detail.
3. How to read List:
 - The reference number corresponds with illustration or photo number of that particular parts list.

This number corresponds with the Figure Number

- - - This number corresponds with the individual parts index number in that figure.

— A small "X" indicates the inability to show that particular part in the Photo or Illustration.

12-115X

Ref. No.	Parts No.	Description
----------	-----------	-------------

Ref. No.	Parts No.	Description
	FLYWHEEL BLOCK #13	
12-115X	800425	Flywheel Block Assy Comp
12-116	244506	Flywheel Only
12-117N	244754	Felt, Flywheel
12-118	251324	Main Metal Case
12-119	253080	Main Metal

4. The symbol numbers shown on the P.C. Board list can be matched with the Composite Views of Components of the Schematic Diagram or Service Manual.
5. Please utilize separate "Common List for Service Parts" for Resistor Parts orders.
6. The shape of the parts and parts name, etc. can be confirmed by comparing them with the parts shown on the Electrical Parts Table of P.C. Board.
7. Both the kind of part and installation position can be determined by the Parts Number. To determine where a parts number is listed, utilize Parts Index at end of Parts List.
 - It is necessary first of all to find the Parts Number. This can be accomplished by using the Reference Number listed at right of parts number in the Parts Index. (Meaning of ref. no. outlined in Item 3 above).
8. Utilize separate "Price List for Parts" to determine unit price. The most simple method of finding parts Price is to utilize the reference number.

CAUTION: 1. When placing an order for parts, be sure to list the parts no., model no., and description. There are instances in which if any of this information is omitted, parts cannot be shipped or the wrong parts will be delivered.

2. Please be careful not to make a mistake in the parts no. If the parts no. is in error, a part different from the one ordered may be delivered.

3. Because parts number and parts unit supply in the Preliminary Service Manual (Basic Parts List) may be partially changed, please use this parts list for all future reference.

WARNING: ⚠ INDICATES SAFETY CRITICAL COMPONENTS. FOR CONTINUED SAFETY, REPLACE SAFETY CRITICAL COMPONENTS ONLY WITH MANUFACTURER'S RECOMMENDED PARTS.

AVERTISSEMENT: ⚠ IL INDIQUE LES COMPOSANTS CRITIQUES DE SURETE. POUR MAINTENIR LE DEGRE DE SECURITE DE L'APPAREIL NE REMPLACER LES COMPOSANTS DONT LE FONCTIONNEMENT EST CRITIQUE POUR LA SECURITE QUE PAR DES PIECES RECOMMANDEES PAR LE FABRICANT.

1. RECOMMENDED SPARE PARTS

Because, if the parts listed below are on hand, almost any repair can be accomplished, we suggest that you stock these Recommended Spare Parts Items.

REF. NO.	PARTS NO.	DESCRIPTION
E-1	BM307613	MOTOR T16056-M0827V
E-2	ED201967	D LED LN26RP R1 D
E-3	ED201968	D LED LN36BP GRN
E-4	ED201969	D LED LN46YP ORG
E-5	FD301911	D SILICON H DS448
E-6	ED206212	D SILICON H DS448FK2 F07
E-7	ED522472	D SILICON HF-1Z 200/0.6A
E-8	ED309859	D SILICON RH-1S 600/0.2A
E-9	ED523618	D SILICON SF-1.8 800/0.2A
E-10	ED200468	D SILICON V DS448 VB3
E-11	ED307645	D VACTOR IS2688
E-12	ED310025	D ZENER H HZ6L A2
E-13	ED307752	D ZENER H HZ6L B2
E-14	ED307690	D ZENER H HZ7L A1
E-15	EF318608	Δ FUSE GGS A 250V 1A (C.A)
E-16	EF309387	Δ FUSE TSC A 250V 1A (J)
E-17	FJ300069	DL DL102601D-221
E-18	EL300149	DL MS-15 (N2-A)
E-19	EL300150	DL MS-15 (N2-B)
E-20	EL200556	DL MS-15N-C
E-21	EL201970	IC ANS750
E-22	EL201972	IC ANS760
E-23	EL307616	IC AN608P
E-24	EL300128	IC AN612
E-25	EL300141	IC AN614
E-26	EL307672	IC CA3240E
E-27	EL300121	IC HA11720
E-28	EL300130	IC HD440072
E-29	EL201966	IC LM2904
E-30	EL301963	IC MP4438
E-31	EL307644	IC NJM4556D
E-32	EL13390	IC NJM4558D
E-33	EL133797	IC TC4001BP
E-34	EL324355	IC TL082CP
E-35	EL311392	IC μPC358C
E-36	EL307617	IC μPC396C
E-37	EL310031	IC μPC78L05
E-38	EL307618	IC VC-1
E-39	EL307715	IC VC-3
E-40	EL307619	IC VC-4
E-41	EL300840	OSC XTAL HC-18/U 14.318180MHZ
E-42	EL310203	CONNECTOR REC-0630-01-020
E-43	EL307403	DIN I TCS817-060 L 7P
E-44	FJ307693	PHONE J 2P HSJ0289-050 2.5
E-45	EO301916	Δ COIL DEF. VIDICON XVC-553C
E-46	EO301630	COIL CA-TV FLYBACK VHT-4
E-47	EO311396	COIL DEF VIDICON ELY-15V101A
E-48	ER307628	Δ R FUSE FN19 1/4W 270J
E-49	ER301631	FILTER LC BP CBPF1 3.80MHZ
E-50	ER301914	FILTER LC LP CLPF3
E-51	ES307659	SW SLIDE MSS-P 24
E-52	ES300122	SW TACT EVO-QBR08K
E-53	ES307404	SW TACT KHC10014
E-54	ET307630	TR FET 2SK218 P
E-55	ET200479	TR 2SA1115 D.E.F
E-56	ET200558	TR 2SA1115 E.F
E-57	ET554657	TR 2SA733A P.Q
E-58	ET330427	TR 2SB772 E.P
E-59	ETS17263	TR 2SC1312R G.H
E-60	ET305368	TR 2SC2264
E-61	ET313560	TR 2SC2291 G.H
E-62	ET330516	TR 2SC1371 C.D
E-63	ET200480	TR 2SC2603 D.E.F
E-64	ET200505	TR 2SC2603 E.F
E-65	ET330429	TR 2SC641K B.C
E-66	ET304710	TR 2SC9448 K.P
E-67	ET307571	TR 2SD781
E-68	EU307635	Δ CRT 40CB4M
E-69	EU307614	Δ IMAGE-F VIDICON S4094

REF. NO.	PARTS NO.	DESCRIPTION
E-70	EV201964	VR ROTARY 16W1050A B102
E-71	VC0307660	LENS J6-11-14 3C AF
E-72	VC0307615	MIC EMU-4628A 2.00K

2. VIDEO (1) P.C BOARD BLOCK

REF. NO.	PARTS NO.	DESCRIPTION
2-1	BAV3003A130A	VIDEO PC (1) BLK VC-X1U
2-1C1	EI300128	IC AN612
2-1C2	EI307617	IC μPC396C
2-1C3	EI307616	IC AN608P
2-1C4	EI307618	IC VC-1
2-1C5	EI300121	IC HA11720
2-1C6	EI300141	IC AN614
2-1C7	EI133797	IC TC4001BP
2-1C8	EI300130	IC HD440072
2-TR1,2	ET200505	TR 2SC2603 E.F
2-TR3	ET200558	TR 2SA1115 E.F
2-TR4,5	ET200505	TR 2SC2603 E.F
2-TR6	ET200558	TR 2SA1115 E.F
2-TR7to13	ET200505	TR 2SC2603 E.F
2-TR14to16	ET200479	TR 2SA1115 D.E.F
2-D1	ED200468	D SILICON V DS448 VB3
2-D2	ED307645	D VACTOR IS2688
2-VC1	EV300073	C S-FIX H CTW13D112 5.0-10
2-VR1	EV307706	R S-FIX H H0651A 3P 0.05W
2-VR2	EV307621	R S-FIX H H0651A 3P 0.05W
2-VR3	EV302012	R S-FIX H H0651A 3P 0.05W
2-VR4	EV307705	R S-FIX H H0651A 3P 0.05W
2-VR5	EV307620	R S-FIX H H0651A 3P 0.05W
2-VR6to8	EV307621	R S-FIX H H0651A 3P 0.05W
2-VR9,10	EV307653	R S-FIX H H0651A 3P 0.05W
2-L1	EO485278	COIL FIX 1 FL05H 220μH K
2-L2	EO243966	COIL FIX 1 FL05H 820μH K
2-L3,4	EO322395	COIL FIX 1 EL0810SKJ
2-L5	EO357287	COIL FIX 1 FL05H 100μH K
2-L6	EO307780	COIL FIX 1 LFI 39μH J
2-L7	EO350763	COIL FIX 1 FL05H 150μH K
2-CR1	ER307744	COMP CR 10-0040
2-CR2	ER302059	COMP RD 08-0050
2-CR3	ER302060	COMP RD 08-0051
2-X1	EL300840	OSC XTAL HC-18/U 14.318180MHZ
2-DL1	EI300069	DL DL102601D-221
2-DL2	EI300149	DL MS-15 (N2-A)
2-DL3	EI200556	DL MS-15N-C
2-R40	ER307757	R MF H F10 1/4W 5111F
2-R41	ER307764	R MF H F10 1/4W 2211F
2-R42	ER307754	R MF H F10 1/4W 4321F
2-R47	ER307757	R MF H F10 1/4W 5111F
2-R48	ER307764	R MF H F10 1/4W 2211F
2-R49	ER307754	R MF H F10 1/4W 4321F
2-C34	EC300193	C CCV F05 NP5M 100M 16NC

3. VIDEO (2) P.C BOARD BLOCK

REF. NO.	PARTS NO.	DESCRIPTION	REF. NO.	PARTS NO.	DESCRIPTION
3-1	BAV3003A240A	VIDEO PC (2) BLK VC-X1U	3-R71	FR307685	R MF H 1/2W 4324G
3-1C1	E1300141	IC AN614	3-R73	FR307764	R MF H F10 1/4W 2211F
3-1C2	E1307619	IC VC-4	3-C6	1-C200948	C EC V F05 NP SM 160M 50DC
3-1C3	E1311392	IC μ PC358C	3-C22	1-C307684	C EC V F05 NP SM R47M 50DC
3-1C4	E1307616	IC AN608P	3-C30	FC307684	C EC V F05 NP SM R47M 50DC
3-1C5	E1300141	IC AN614	3-C37	FC300193	C EC V F05 NP SM 100M 16DC
3-1C6	E1307617	IC μ PC596C	3-C44	EC307793	C EC V F05 NP SM 220M 10DC
3-1C7	E1307619	IC VC-4	3-C47	EC307793	C EC V F05 NP SM 220M 10DC
3-1C8	E1311392	IC μ PC358C			
3-1C9	E1300141	IC AN614			
3-1C10	E1307617	IC μ PC596C			
3-1C11	E1307619	IC VC-4			
3-1C12	E1311392	IC μ PC358C			
3-1C13	E1307672	IC CA3240E			
3-1C14	E1324255	IC TL082CP			
3-1C15	E1311392	IC μ PC358C			
3-1C16	E1307644	IC NJM4556D			
3-1C17	E1307644	IC NJM4556D			
3-TR1	ET304710	TR 25C9445 K,P			
3-TR2	ET200558	TR 25A1115 E,F			
3-TR3	ET200505	TR 25C2603 E,F			
3-TR4,5	ET200558	TR 25A1115 E,F			
3-TR6	ET313560	TR 25C2291 G,H			
3-TR7	ET330429	TR 25C641K B,C			
3-TR8,9	ET200505	TR 25C2603 E,F			
3-TR10	ET200558	TR 25A1115 E,F			
3-TR11to16	ET200505	TR 25C2603 E,F			
3-TR17to19	ET200558	TR 25A1115 E,F			
3-TR20,21	ET200505	TR 25C2603 E,F			
3-TR22	ET200558	TR 25A1115 E,F			
3-TR23	ET304710	TR 25C9445 K,P			
3-D1	ED200468	D SILICON V DS448 VB3			
3-D2	ED301911	D SILICON H DS448			
3-SW1,2	ES300122	SW TACT EVQ-QBR08K			
3-VR1,2	EV307624	R S-FIX H H0651A 3P 0.30W			
		222			
3-VR3	EV307694	R S-FIX H H0651A 3P 0.05W			
		472			
3-VR4	EV307621	R S-FIX H H0651A 3P 0.05W			
		103			
3-VR5	EV307694	R S-FIX H H0651A 3P 0.05W			
		472			
3-VR6	EV307621	R S-FIX H H0651A 3P 0.05W			
		103			
3-VR7to12	EV307624	R S-FIX H H0621A 3P 0.30W			
		222			
3-VR13,14	EV307694	R S-FIX H H0651A 3P 0.05W			
		472			
3-VR15	EV307694	R S-FIX H H0651A 3P 0.05W			
		104			
3-VR16	EV307624	R S-FIX H H0621A 3P 0.30W			
		222			
3-VR17	EV330364	R S-FIX V EVN-B1A 3P 504			
3-L1,2	EO310075	COIL FIX 1 FL05H 100 μ H K			
3-L3,4	EO350763	COIL FIX 1 FL05H 150 μ H K			
3-L5	FO322395	COIL FIX 1 EL08105K			
		100 μ H K			
3-FL1	ER301914	FILTER LC LP CLPF3			
3-FL2	ER301631	FILTER LC BP CBPF1 3.80MHZ			
3-CR1	E1B319178	COMP RD 06-0065 PART			
3-CR2	ER302061	COMP CR 10-0036			
3-CR3	11B319253	COMP RD 06-0064 PART			
3-CR4	ER302061	COMP CR 10-0036			
3-D11	E1300150	DL MS-15 (N2-B)			
3-R46	LR307755	R MF H F10 1/4W 5621F			
3-R47	ER330234	R MF H F10 1/4W 3010F			
3-R48	LR330235	R MF H F10 1/4W 3650F			
3-R49	ER307767	R MF H F10 1/4W 2741F			
3-R50	FR307730	R MI H F10 1/4W 7502F			
3-R51	ER307668	R ME V 1/4W 1504J			
3-R59	ER307768	R MI H F10 1/4W 4323F			
3-R70	FR307685	R MI H 1/2W 4324G			

When ordering parts, please quote Parts Number, Description and Model Number.

4. H & D P.C BOARD BLOCK

REF. NO.	PARTS NO.	DESCRIPTION
4-1	BAV3003A210A	H & D PC BLK VC-X1U
4-1C1	E1307715	IC VC-3
4-1C2	E1213390	IC NJM4558D
4-1C3	E1307644	IC NJM4556D
4-1C4	E1310031	IC μ PC78L05
4-1C5	E1311392	IC μ PC358C
4-1C6	E1300128	IC AN612
4-TR1	ET554657	TR 25A733A P,Q
4-TR2	ET307571	TR 25D781
4-TR3,4	ET200505	TR 25C2603 E,F
4-TR5,6	ET554657	TR 25A733A P,Q
4-TR7	ET200479	TR 25A1115 D,E,F
4-TR8,9	ET517263	TR 25C1312R G,H
4-TR11	ET313560	TR 25C2291 G,H
4-D1	ED200468	D SILICON V DS448 VB3
4-D2,3	ED522472	D SILICON HF-12 200/0.6A
4-D4	ED300752	D ZENER H HZ6L B2
4-D5	ED200468	D SILICON V DS448 VB3
4-D6	ED310025	D ZENER H HZ6L A2
4-D7	ED200468	D SILICON V DS448 VB3
4-FR1	FR307628	R FUSE FN19 1/4W 220J
4-VR1	EV307621	R S-FIX H H0651A 3P 0.05W
		103
4-VR2	EV307653	R S-FIX H H0651A 3P 0.05W
		102
4-VR3	EV307656	R S-FIX V EVM-30G 3P 0.30W
		105
4-VR4	EV307637	R S-FIX H H0651A 3P 0.05W
		225
4-VR5	EV307654	R S-FIX H H0651A 3P 0.05W
		224
4-VR6to13	EV307621	R S-FIX H H0651A 3P 0.05W
		103
4-VR14	EV307652	R S-FIX H H0651A 3P 0.30W
		474
4-VR15	EV307654	R S-FIX H H0651A 3P 0.05W
		224
4-VR16	EV307621	R S-FIX H H0651A 3P 0.05W
		103
4-VR17	EV307629	R S-FIX H H0621A 3P 0.30W
		223
4-L1,2	EO357287	COIL FIX 1 FL05H 100 μ H K
4-L3	EO307409	COIL CA TV LINEARITY
		CANS-46682
4-L4,5	EO244011	COIL FIX 1 FL09H 22MH J
4-T1	EO307646	COIL CA TV HIGH VOLT
		VHT-5
4-CR1	ER302056	COMP RD 08-0048
4-CR2	ER307771	COMP RD 08-0057
4-CR3	ER307769	COMP R 02-0045
4-CR4	ER307770	COMP R 02-0046
4-CR5	ER302058	COMP R 02-0041
4-CR6	ER302220	COMP R 02-0059
4-R9	FR311423	R MF H F10 1/4W 2004F
4-R14	ER311422	R MF H F10 1/4W 1004F
4-R19	ER330304	R MF H F10 1/4W 1102F
4-R20	ER307729	R MF H F10 1/4W 1502F
4-R21	ER307756	R MF H F10 1/4W 4752F
4-R22	ER307755	R MF H F10 1/4W 3922F
4-R23	ER307759	R MF H F10 1/4W 9091F
4-R24	ER307729	R MF H F10 1/4W 1502F
4-C7	EC307778	C PP V ECQ-P 4701G 100DC
4-C11	EC307407	C EC V CHU1K0 450DC
4-C12	EC311568	C EC V R5A 1K0 350DC
4-C13	EC307724	C CE V E 472P 600DC
4-C17to19	EC201440	C EC V F05 SL 1R0 160DC
4-C22	FC307646	C MY V AMR 223M 600DC
4-C26	EC307722	C CE V E 4722 1000DC

When ordering parts, please quote Parts Number, Description and Model Number.

5. PRE AMP P.C BOARD BLOCK

REF. NO.	PARTS NO.	DESCRIPTION
5-1	BAV3003A190A	PRE AMP PC BLK VC-X1U
5-TR1	ET307630	TR FET 25K218 P
5-TR2to6	ET330526	TR 25C2377 C,D
5-D1	ED307690	D ZENER H HZ7L A1
5-D2	ED301911	D SILICON H DS448
5-VC1	EC307634	C S-FIX V ECV-12W10x60
5-VR1	EV307633	R S-FIX V EVN30C 3P 102
5-VR2	EV307691	R S-FIX V EVN30C 3P 202
5-L1	EO307632	COIL CA, TV PERSIVAL
		ELT-12R003
5-L2	EO357287	COIL FIX 1 FL05H 100 μ H K
5-L3	EO307751	COIL FIX 1 LAL04KB 60 μ H J
5-C3,4	EC307692	C MY V AMX 223K 100DC
5-C7	EC452665	C MC V FM 200J 500DC
5-C9	EC307711	C PP V APS 102J 100DC
5-C12	EC589680	C MC V FM 160J 500DC

6. PANEL P.C BOARD BLOCK

REF. NO.	PARTS NO.	DESCRIPTION
6-1	BDV3003A260A	PANEL PC BLK VC-X1U
6-1C1	E1201963	IC MP4438
6-1C2	E1201966	IC LM2904
6-TR1	ET200479	TR 25A1115 D,E,F
6-TR2	ET200480	TR 25C2603 D,E,F
6-TR3	ET200479	TR 25A1115 D,E,F
6-TR4,5	ET200480	TR 25C2603 D,E,F
6-TR6	ET200479	TR 25A1115 D,E,F
6-TR7	ET200480	TR 25C2603 D,E,F
6-TR8	ET330429	TR 25C641K B,C
6-TR9	ET200479	TR 25A1115 D,E,F
6-D1to5	ED200212	D SILICON H DS448Fx2 F07
6-SW1,2	ES307404	SW TACT KHC10014
6-VR1	EV307629	R S-FIX H H0621A 3P 0.30W
		223
6-VR2	EV307709	R S-FIX H H0651A 3P 0.05W
		223
6-VR3	EV307737	R S-FIX H EVN33AA00 3P 303
6-L1	EO574187	COIL FIX 1 FL05H 100 μ H M
6-CR1	ER307739	COMP RD 08-0059
6-CR2	ER307740	COMP RD 08-0060
6-CR3,4	ER307741	COMP R 02-0052
6-CR5	ER307742	COMP CR 10-0042
6-CR6	ER307743	COMP R 02-0053
6-R1	ER307756	R MF H F10 1/4W 4752F
6-R2	ER307707	R MF H F10 1/4W 2000F
6-R4	ER307781	R MF H F10 1/4W 2002F

When ordering parts, please quote Parts Number, Description and Model Number.

7. EVF P.C BOARD BLOCK

REF. NO.	PARTS NO.	DESCRIPTION
7-1	BAV3003A110A	EVF PC BLK VC-X1U
7-IC1	EI201970	IC AN5750
7-IC2	EI201972	IC AN5760
7-TR1 to 5	ET200480	TR 2SC2603 D,E,F
7-TR6	ET305468	TR 2SC2364
7-TR7	ET200480	TR 2SC2603 D,E,F
7-D1	ED307690	D ZENER H HZ7L A1
7-D2,3	ED200212	D SILICON H DS448FX2 F07
7-D4 to 6	ED309859	D SILICON RH-1S 600/0.2A
7-D7	ED523618	D SILICON SF-1-8 800/0.2A
7-D8	ED201967	D LED LN26RP RED
7-D9	ED201968	D LED LN36BP GRN
7-D10	ED201969	D LED LN46YP ORG
7-905	EJ311393	SOCKET CRT SPECIAL-7P S7-506P-44
7-VR1	EV522404	R S-FIX V V8K1-1 3P 102
7-VR2	EV522663	R S-FIX V V8K1-1 3P 104
7-VR3	EV555884	R S-FIX V V8K1-1 3P 303
7-VR4	EV475470	R S-FIX V V8K1-1 3P 103
7-VR5	EV522652	R S-FIX V V8K1-1 3P 105
7-VR6	EV307655	R S-FIX H H0621A 3P 0.30W 223
7-L1	EO322395	COIL FIX 1 EL0810SKI 100uH K
7-L2	EO201965	COIL CA. TV LINEARITY LCH-10
7-L3	EO311396	COIL DEF VIDICON ELY-15V101A
7-L4	EO301630	COIL CA. TV FLYBACK VHT-4
7-L5	EO321699	COIL FIX 1 EL0810SKI 47uH J
7-CR1,2	EI309982	COMP CR EXR-F221K-102C
7-CR3	EI309996	COMP CR EXR-F101K-103C
7-CR4	EI318235	COMP CR EXR-F100K-474C
7-R26	ER307749	R CB H SNP FS RDS 1/4W 180J
7-C17	EC307773	C TT V DA 2R2K 10DC
7-C18	EC307772	C TT V D 4R7K 6.3DC
7-C29	EC307725	C PP V ECQ-P 103J 1000C
7-C31	EC307722	C CE V E 472Z 1000DC
7-C32	EC243617	C MY V AMS 272J 200DC
7-C33	EC307650	C CE V E 222Z 1000DC

8. REC P.C BOARD BLOCK

REF. NO.	PARTS NO.	DESCRIPTION
8-1	BAV3003A060A	REC PC BLK VC-X1U
8-J18	EJ308102	SOCKET HOUSING M62-02-6251SA 2P
8-2	EA307953B	PC REC
8-3	ZG307876	SP PLATE REC

When ordering parts, please quote Parts Number, Description and Model Number.

10. FINAL ASSEMBLY BLOCK

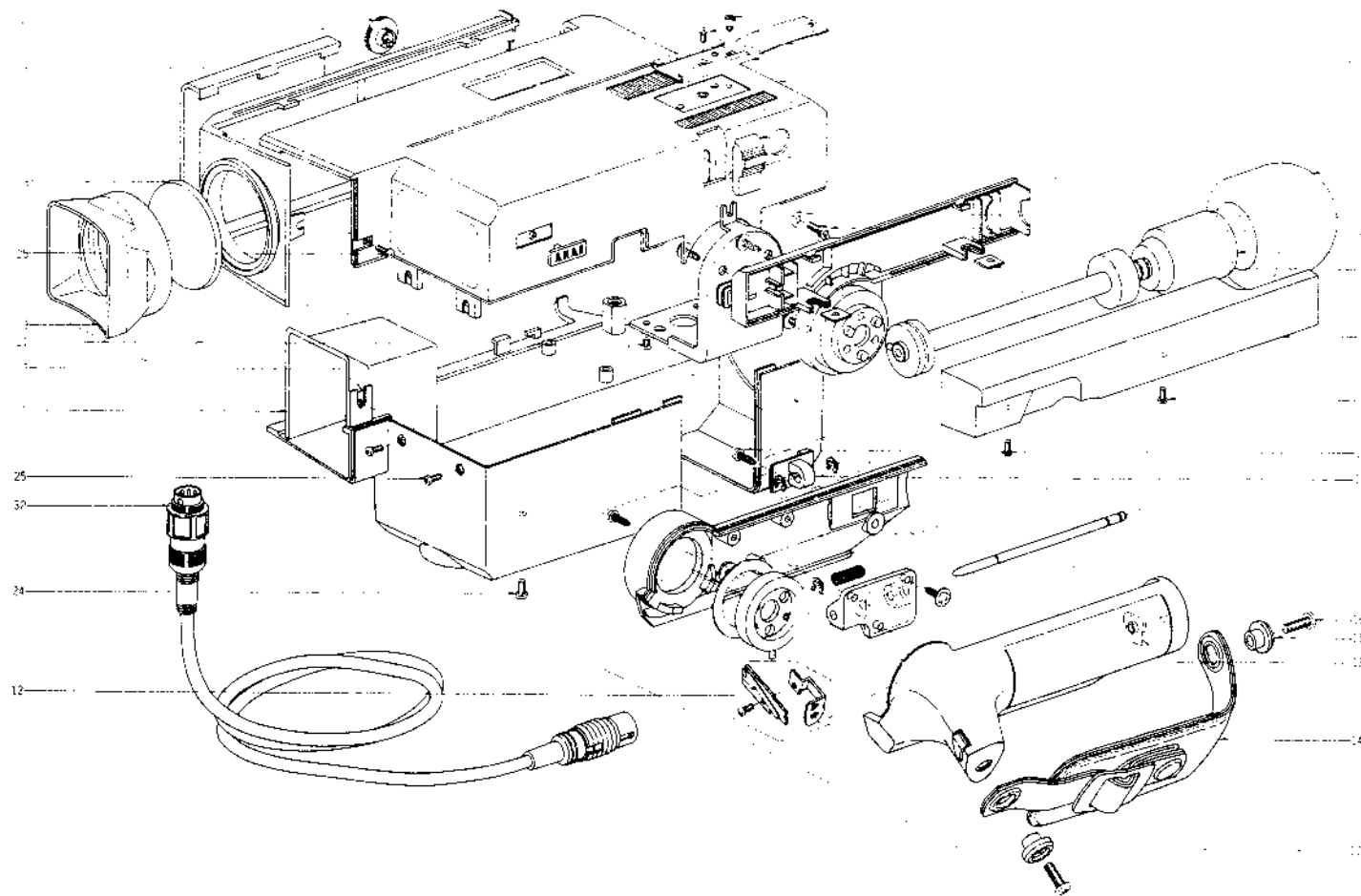

FINAL ASSEMBLY BLOCK

REF. NO.	PARTS NO.	DESCRIPTION
CASE CAMERA (A) BLK		
10-1	BC307895	CASE CAMERA (A)
10-2	ZW307859	NUT (A)
CASE CAMERA (B) BLK		
10-3	BDV3003A120B	CASE CAMERA (B) BLK VC-X1U(C) (C.A)
10-4x	BDV3003A120A	CASE CAMERA (B) BLK VC-X1U(J)
10-5	SK307884	KNOB ND

REF. NO.	PARTS NO.	DESCRIPTION
CASE CAMERA (C) BLK		
10-6	BDV3003A130B	CASE CAMERA (C) BLK VC-X1U(C) (C.A)
10-7x	BDV3003A130A	CASE CAMERA (C) BLK VC-X1U(J)
10-8	VC307661	LENS EYE
10-9	VC307938	HOOD EYECAP
CASE GRIP BLK		
10-10	BDV3003A020A	CASE GRIP BLK VC-X1U
10-11	SK307886	KNOB LOCK
10-12	VCV3003A050A	HOLDER REC BLK VC-X1U
10-13	ZW307872	NUT (B)

REF. NO.	PARTS NO.	DESCRIPTION
10-14	VC307942	GRIP BAND
10-15	VC307887	COLLAR GRIP BAND
10-16	ZS558090	BDU40x14STL BNI
10-17	ZS311098	T2PAN30x10STL BNI
CASE MIC BLK		
10-18	SP307899	CASE MIC (B)
10-19	VC307615	MIC EMU-4629A 2.00K
10-20	ZS307944	PAN26x05STL BNI
FINAL ASSEMBLY BLK		
10-21	ZS309374	CTS26x08STL BNI

REF. NO.	PARTS NO.	DESCRIPTION
10-22	ZS419938	6RB30x080SCM PKR R
10-23	ZW306464	PW31x070x050STL CMT
10-24	ZS593908	PAN30x06STL NI3
10-25	ZS410231	PAN26x06STL NI3
10-26x	ZS306001	T2PAN26x08STL CMT
10-27	AX307863	ACCS SHOE
10-28	ZS419850	CTS26x05STL NI3
10-29	ZS307864	SP PLATE ACCS SHOE
10-30	ZS307865	SCREW ACCS SHOE
10-31	SK307882	KNOB IRIS
10-32	EW201962	CAMERA CABLE 1993
10-33	VC311418	MIC WIND SCREW (LARGE)

When ordering parts, please quote Parts Number, Description and Model Number.

INDEX

PARTS NO.	REF. NO.	PARTS NO.	REF. NO.	PARTS NO.	REF. NO.	PARTS NO.	REF. NO.
AX307863	10-17	EI300141	3-IC5	FR307741	6-CR3,4	EV307621	3-VR6
BAV3003A060A	8-3	EI300141	3-IC9	FR307742	6-CR5	EV307621	4-VR16
BAV3003A060A	9-1	EI300148	2-DL2	FR307743	6-CR6	EV307621	4-VR6to13
BAV3003A110A	7-1	EI300150	3-DL1	FR307744	2-CR1	EV307621	4-VR1
BAV3003A190A	3-1	EI300840	2-K1	ER307740	7-R26	EV307624	3-VR7to12
BAV3003A210A	4-1	EI302616	2-IC3	FR307744	2-R42	EV307624	3-VR1,2
BAV3003A230A	2-1	EI307616	3-IC4	ER307754	2-R49	EV307624	3-VR16
BAV3003A240A	3-1	EI307617	2-IC2	ER307755	4-R22	EV307629	4-VR17
BC307895	10-1	EI307617	3-IC6	ER307756	4-R21	EV307629	6-VR1
BDV3003A020A	10-10	EI307617	3-IC10	ER307756	6-R1	EV307633	5-VR1
BDV3003A120A	10-4x	EI307618	2-IC4	ER307757	2-R40	EV307637	4-VR4
BDV3003A120B	10-3	EI307619	3-IC2	ER307757	2-R47	EV307652	4-VR14
BDV3003A130A	10-7x	EI307619	3-IC7	FR307758	3-R46	EV307653	2-VR9,10
BDV3003A130B	10-6	EI307619	3-IC11	ER307759	4-R23	EV307653	4-VR2
BDV3003A260A	6-1	EI307644	3-IC16	ER307764	2-R41	EV307654	4-VR15
BM307613	9-4	EI307644	3-IC17	ER307764	2-R48	EV307654	4-VR5
EA307953B	8-2	EI307644	4-IC3	ER307764	3-R73	EV307655	7-VR6
EC200948	3-C6	EI307672	3-IC13	FR307767	3-R49	EV307656	4-VR3
EC201440	4-C17to19	EI307715	4-IC1	ER307768	3-R69	EV307691	5-VR2
EC231568	4-C12	EI309982	7-CR1,2	ER307769	4-CR3	EV307694	3-VR5
EC243617	7-C32	EI309996	7-CR3	ER307770	4-CR4	EV307694	3-VR13,14
EC300193	2-C34	EI310031	4-IC4	ER307771	4-CR2	EV307694	3-VR3
EC300193	3-C37	EI311392	3-IC3	ER307781	6-R4	EV307695	3-VR15
EC307407	4-C11	EI311392	3-IC8	ER311422	4-R14	EV307705	2-VR4
EC307634	5-VC1	EI311392	3-IC12	ER311423	4-R9	EV307706	2-VR1
EC307648	4-C22	EI311392	3-IC15	ER330220	4-CR6	EV307709	6-VR2
EC307649	9-24	EI311392	4-IC5	ER330234	3-R47	EV307737	6-VR3
EC307650	7-C33	EI313797	2-IC7	ER330235	3-R48	EV330212	2-VR3
EC307684	3-C22	EI318235	7-CR4	ER330304	4-R19	EV330364	3-VR17
EC307684	3-C30	EI324255	3-IC14	ES300122	3-SW1,2	EV475470	7-VR4
EC307692	5-C3,4	EJ307403	9-11	ES307404	6-SW1,2	EV522404	7-VR1
EC307711	5-C9	EJ307693	9-12	ES307659	9-22	EV522652	7-VR5
EC307722	4-C26	EJ308102	8-118	ET200479	2-TR14to16	EV522663	7-VR2
EC307722	7-C31	EJ310203	9-19	ET200479	4-TR7	EV555884	7-VR3
EC307724	4-C13	EJ311393	7-J905	ET200479	6-TR1	EW201962	10-32
EC307725	7-C29	EJ311395	9-21	ET200479	6-TR3	SK307878	9-26
EC307772	7-C18	EJ328679A	9-13	ET200479	6-TR6	SK307882	10-31
EC307773	7-C17	EJ328679B	9-15	ET200479	6-TR9	SK307883	9-25
EC307778	4-C7	EJ464995	9-14	ET200480	6-TR7	SK307884	10-5
EC307793	3-C44	EO201965	7-L2	ET200480	6-TR2	SK307886	10-11
EC307793	3-C47	EO243966	2-L2	ET200480	6-TR4,5	SP307899	10-18
EC452665	5-C7	EO244012	4-L4,5	ET200480	7-TR1to5	VCB307660	9-3
EC589680	5-C12	EO301630	7-L4	ET200480	7-TR7	VCV3003A050A	10-12
ED200212	6-D1to5	EO301916	9-17	ET200505	2-TR4,5	VC307615	10-19
ED200212	7-D2,3	EO307409	4-L3	ET200505	2-TR1,2	VC307661	10-8
ED200468	2-D1	EO307637	5-L1	ET200505	2-TR7to13	VC307663	9-9
ED200468	3-D1	EO307646	4-T1	ET200505	3-TR8,9	VC307887	10-15
ED200468	4-D5	EO307751	5-L3	ET200505	3-TR11to16	VC307938	10-9
ED200468	4-D7	EO307780	2-L6	ET200505	3-TR20,21	VC307942	10-14
ED200468	4-D1	EO310075	3-L1,2	ET200505	3-TR3	VC311418	10-33
ED201967	7-D5	EO311396	7-L3	ET200505	4-TR3,4	VC780010	9-6
ED201968	7-D9	EO321699	7-L5	ET200558	2-TR3	VC780011	9-5
ED201969	7-D10	EO322395	2-L3,4	ET200558	2-TR6	VT422537	9-16
ED301911	3-D2	EO322395	3-L5	ET200558	3-TR10	ZG307864	10-29
ED301911	5-D2	EO322395	7-L1	ET200558	3-TR17to19	ZG307876	8-3
ED307645	2-D2	EO350763	2-L7	ET200558	3-TR22	ZG312944	9-20
ED307690	5-D1	EO350763	3-L3,4	ET200558	3-TR2	ZS306001	10-26x
ED307690	7-D1	EO357287	2-L5	ET200558	3-TR4,5	ZS307865	10-30
ED307752	4-D4	EO357287	4-L1,2	ET304710	3-TR1	ZS307944	10-20
ED309859	7-D4to6	EO357287	5-L2	ET304710	3-TR23	ZS309374	10-21
ED310925	4-D6	EO485278	2-L1	ET305468	7-TR6	ZS311098	10-17
ED322472	4-D2,3	EO574187	6-L1	ET307571	4-TR2	ZS321537	9-7
ED313618	7-D2	ER301631	3-FL2	ET307630	5-TR1	ZS410231	10-25
EF309387	9-21x	ER301914	3-FL1	ET313560	5-TR6	ZS419850	10-28
EV318605	9-C7	ER302046	4-CR1	ET313560	4-TR11	ZS41993R	10-12
FB319178	3-CR1	ER302058	4-CR5	ET330427	9-10	ZS458090	10-16
FB319253	3-CR3	ER302059	2-CR2	ET330429	3-TR7	ZS493908	10-24
IE200556	2-DL3	FK302060	2-CR3	ET330429	6-1R8	ZW306464	9-8
IE201963	6-IC1	ER302061	3-CR2	ET330526	5-TR2to6	ZW306464	10-23
IE201966	6-IC2	ER302061	3-CR4	ET517263	4-TR8,9	ZW307859	10-2
IE201970	7-IC1	ER307625	4-FR1	ET554657	4-TR1	ZW307872	10-13
IE201972	7-IC2	ER307668	3-R51	ET554657	4-TR5,6		
IE213390	4-IC7	ER307685	3-R70	EU307614	9-18		
IE300069	2-DL1	ER307685	3-R71	EU307635	9-2		
IE300121	2-IC5	ER307709	6-R2	EV201966	9-23		
IE300128	2-IC1	ER307729	4-R20	EV306073	2-UC1		
IE300128	4-IC6	ER307729	4-R24	EV307620	2-VR5		
IE300130	2-IC5	ER307730	3-R50	EV307621	2-VR2		
IE300141	2-IC6	ER307730	6-CR1	EV307621	2-VR6to8		
IE300141	3-IC1	ER307740	6-CR2	EV307621	3-VR4		

SECTION 3

SCHEMATIC DIAGRAM

1. SCHEMATIC DIAGRAM OF ICs
2. VC-XIU NO. 8-1 1621244A BLOCK DIAGRAM
3. VC-XIU NO. 8-2 1621245A CONNECTION DIAGRAM
4. VC-XIU VIDEO (1) NO. 8-3 1621246A SCHEMATIC DIAGRAM
5. VC-XIU VIDEO (2) NO. 8-4 1621247A SCHEMATIC DIAGRAM
6. VC-XIU H & D NO. 8-5 1621248A SCHEMATIC DIAGRAM
7. VC-XIU PANEL NO. 8-6 1621249A SCHEMATIC DIAGRAM
8. VC-XIU EVF NO. 8-7 1621250A SCHEMATIC DIAGRAM
9. VC-XIU AMP NO. 8-8 1621251A SCHEMATIC DIAGRAM

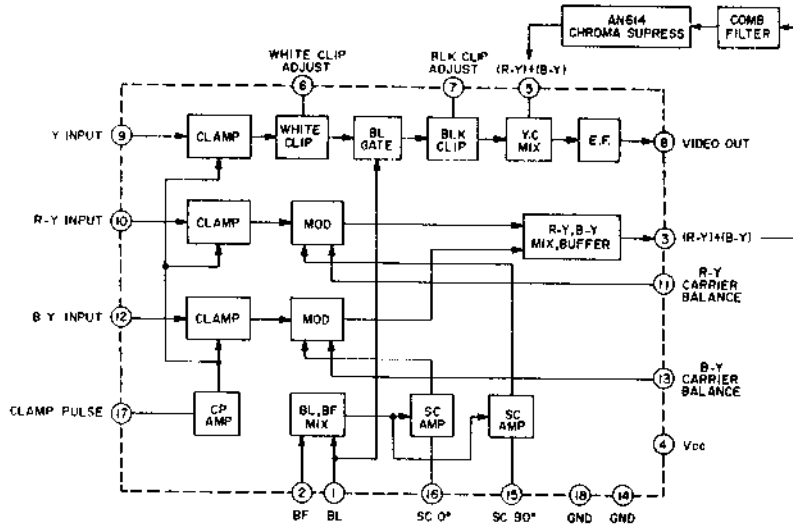

NJM4556D/NJM4558D/NJM4560D/ μ PC358C/
CA3240/TL082CP/LM2904N

MP4438

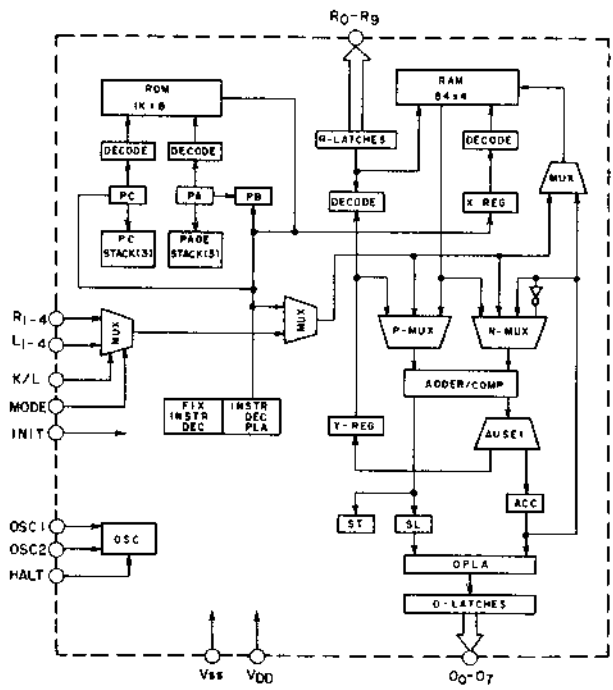
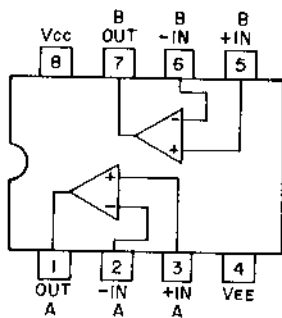

TC4001BP

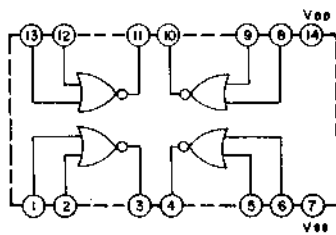

VC-1

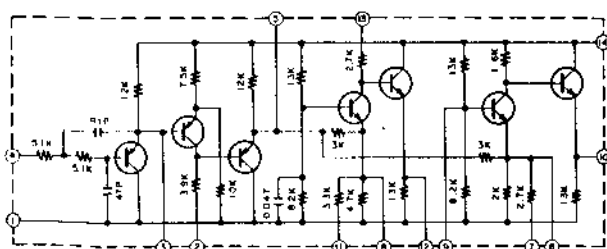

VC-4

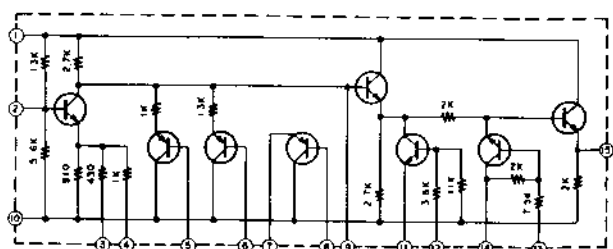

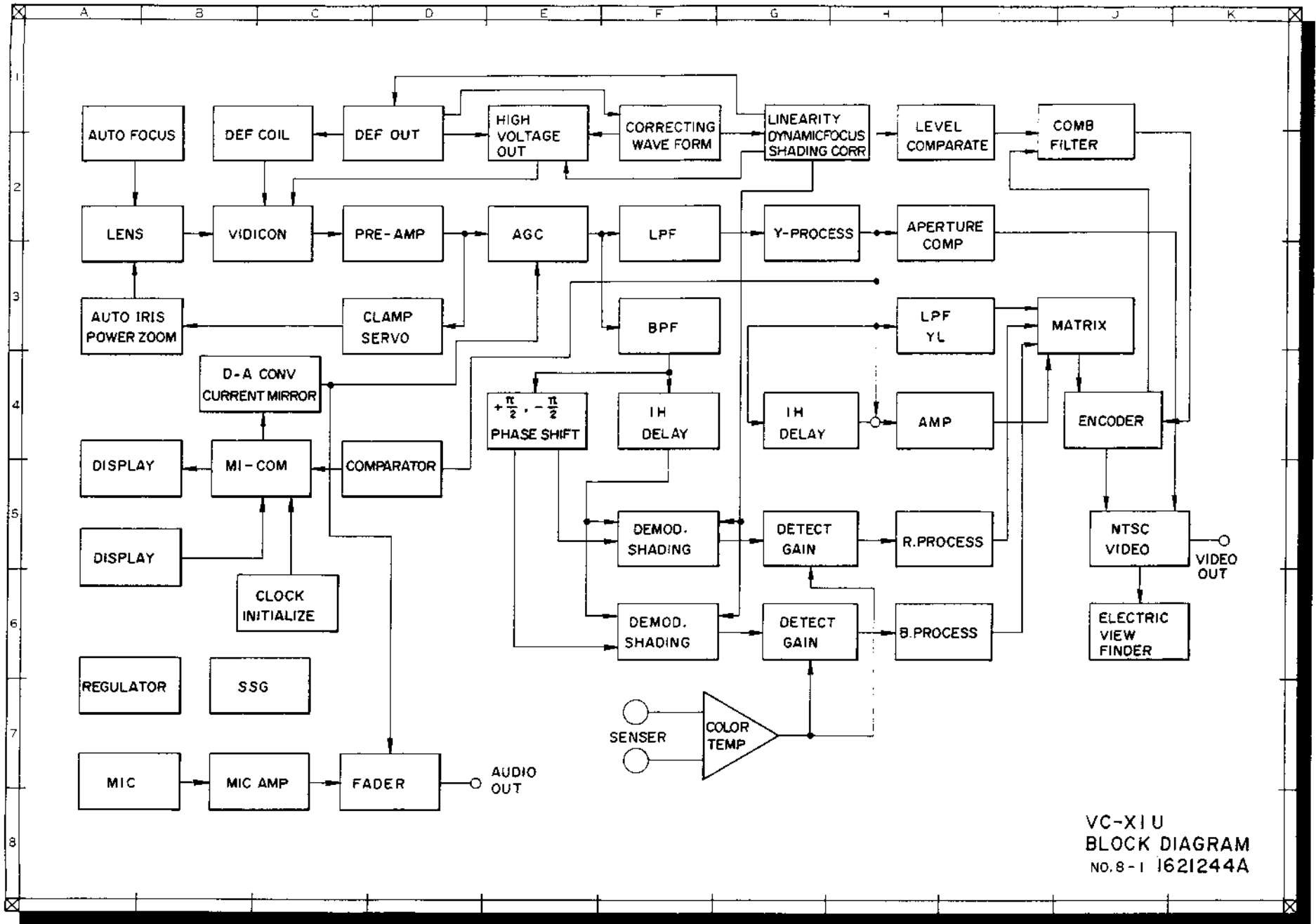

VC-X1U
 BLOCK DIAGRAM
 NO. 8-1 1621244A

VC-XIU

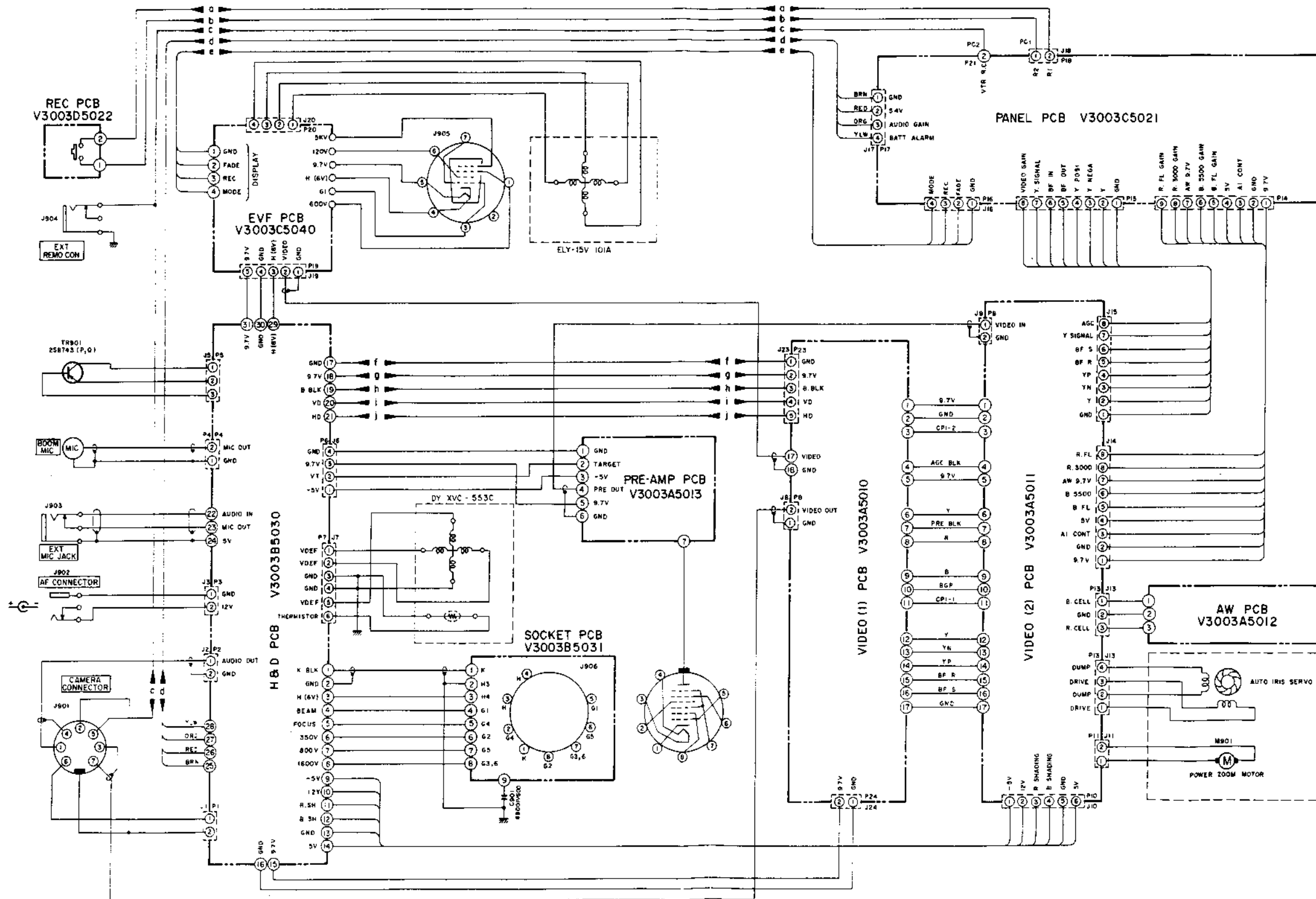

VC-XIU
CONNECTION DIAGRAM
NO. 8-2 1621245A

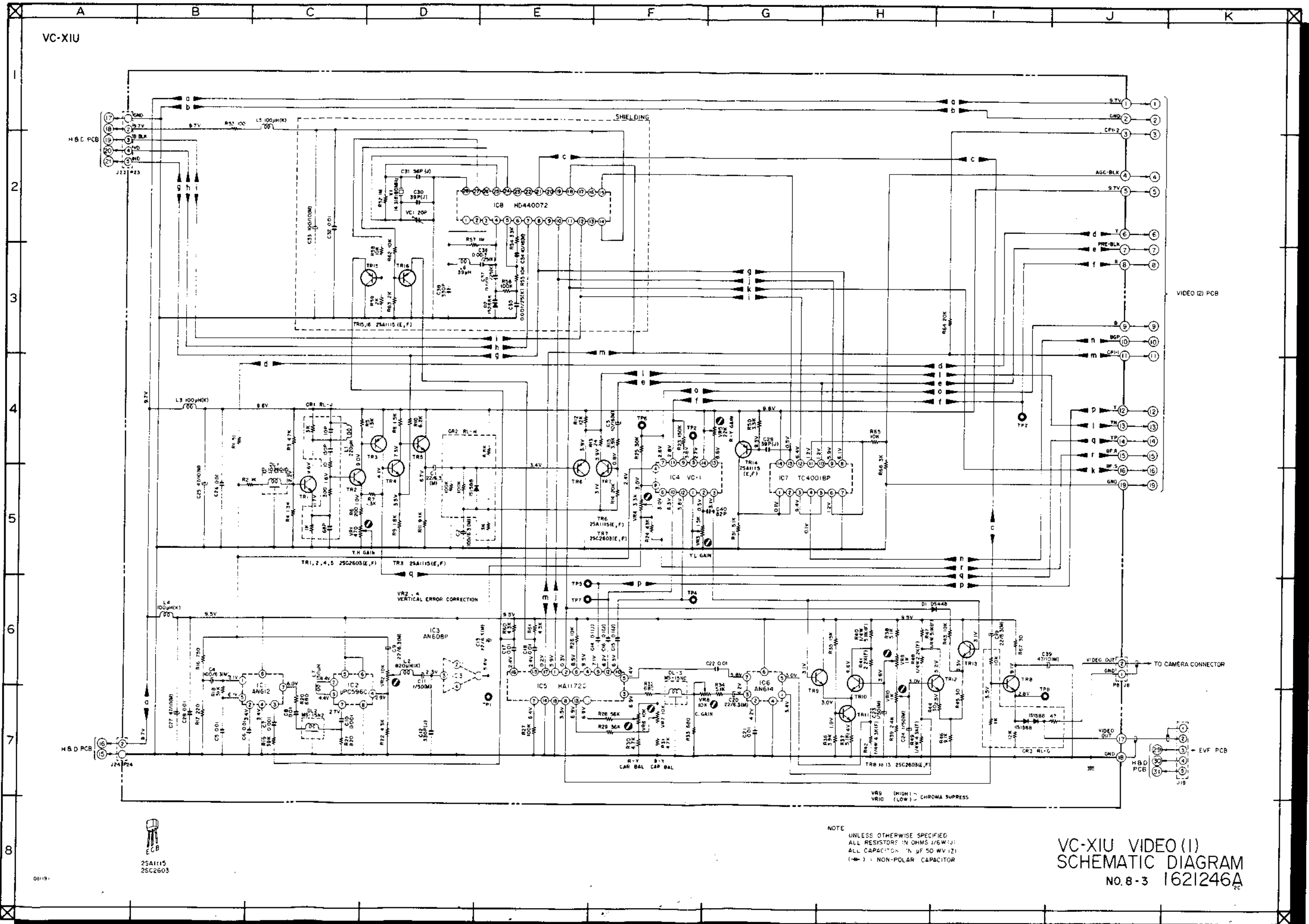

NOTE
 UNLESS OTHERWISE SPECIFIED
 ALL RESISTORS IN OHMS 1/6 WATT
 ALL CAPACITORS IN P.F. 50 WV 121
 (—) = NON-POLAR CAPACITOR

VC-XIU VIDEO (1)
 SCHEMATIC DIAGRAM
 NO. 8-3 1621246A

25A1115
 25C2603

08119

VC-XIU

H&D PCB V3003B5030

EVF PCB
VIDEO(1) PCB

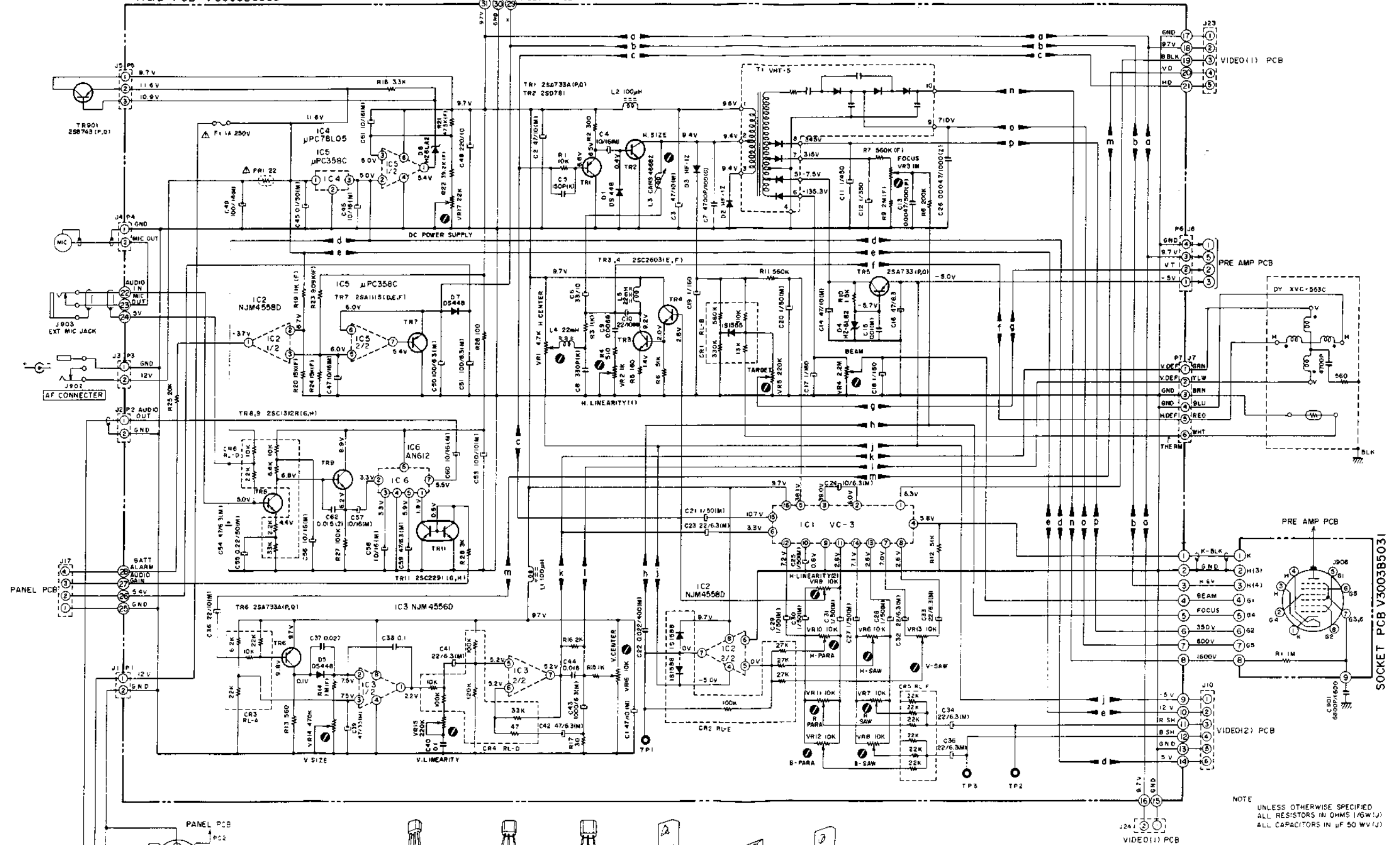

NOTE
UNLESS OTHERWISE SPECIFIED,
ALL RESISTORS IN OHMS (Ω),
ALL CAPACITORS IN μF 50 WV (V)

VC-XIU H&D
SCHEMATIC DIAGRAM
NO. 8-5 162148A

WARNING: INDICATES SAFETY CRITICAL COMPONENTS FOR CONTINUED SAFETY.
REPLACE SAFETY CRITICAL COMPONENTS ONLY WITH MANUFACTURER'S
RECOMMENDED PARTS.
AVERTISSEMENT: Δ IL INDIQUE LES COMPOSANTS CRITIQUES DE SÛRETÉ POUR
MAINTENIR LE DEGRÉ DE SÛRETÉ DE L'APPAREIL. NE REMPLACER LES
COMPOSANTS DONNÉ LE FONCTIONNEMENT EST CRITIQUE POUR LA SÛRETÉ
QUE PAR DES PIÈCES RECOMMANDÉES PAR LE FABRICANT.

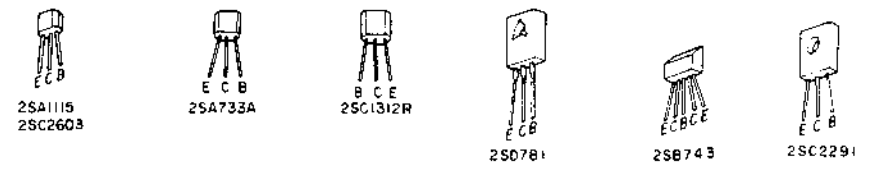

VC-XIU

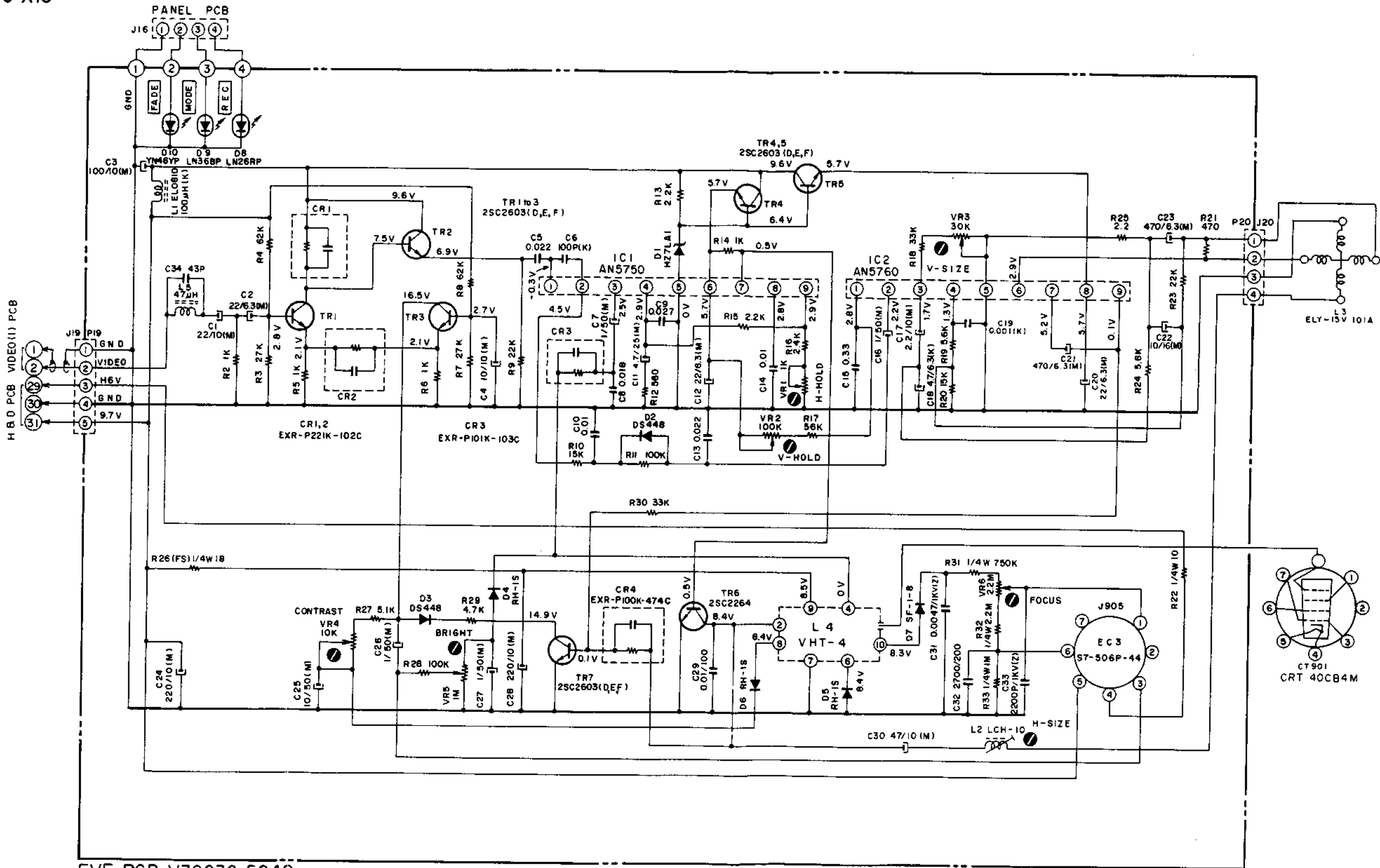

EVF PCB V3003C 5040

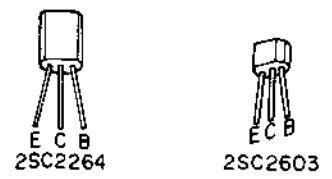

NOTE
UNLESS OTHERWISE SPECIFIED
ALL RESISTORS IN OHMS 1/6W(J)
ALL CAPACITORS IN μ F 50 WV(J)
(FS) = FAIL SAFE RESISTORS

WARNING: THIS CHASSIS CONTAINS COMPONENTS CRITICAL FOR X-RADIATION SAFETY. FOR CONTINUED X-RADIATION SAFETY PLEASE REPLACE WITH A COMPONENT OF THE SAME TYPE.

VC-XIU EVF
SCHEMATIC DIAGRAM
NO. 8-7 1621250A
2C

001195A

VC-XIU

PRE AMP PCB V3003A5013

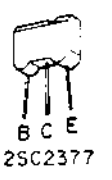
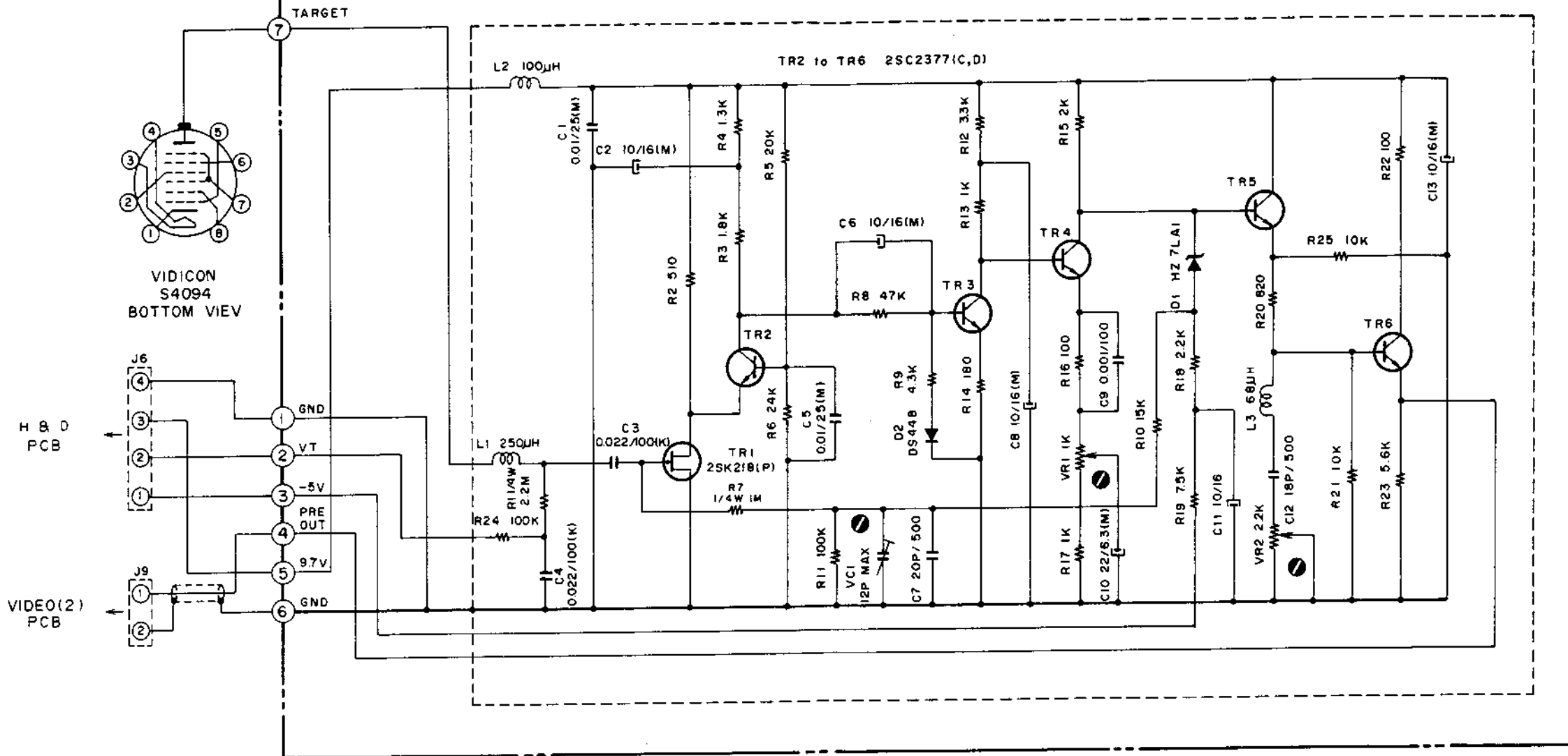

NOTE
UNLESS OTHERWISE SPECIFIED
ALL RESISTORS IN OHMS 1/6W(J)
ALL CAPACITORS IN μF 50WV(J)

VC-XIU AMP
SCHEMATIC DIAGRAM
NO. 8-8 1621251A

001196A