

AKAI SERVICE MANUAL

UC-W5
UC-A5

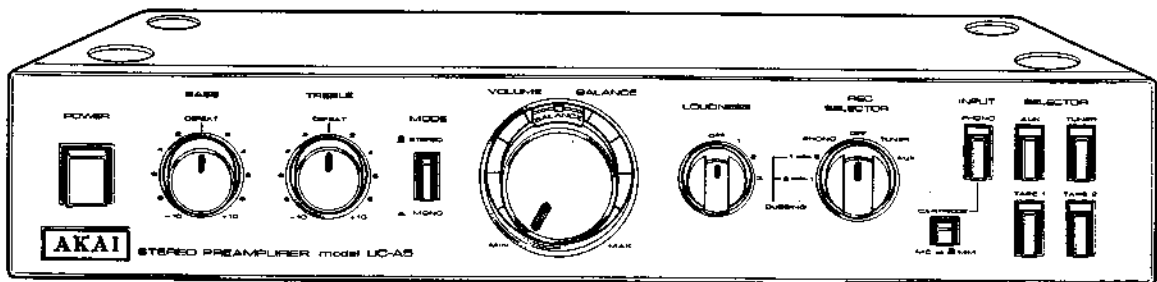
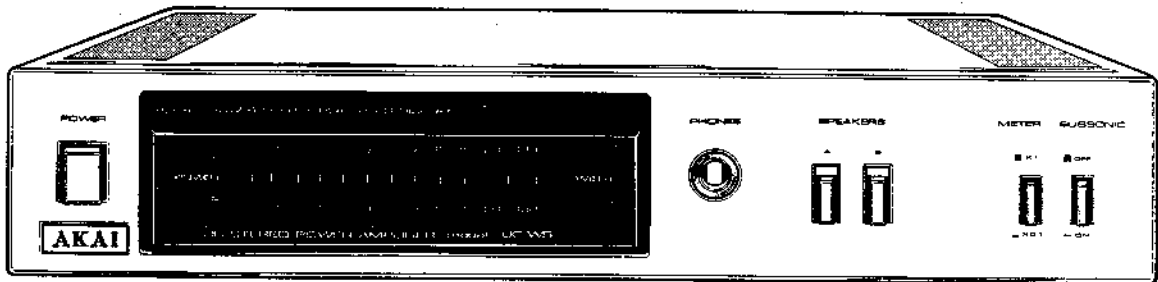

DC STEREO POWER AMPLIFIER

MODEL **UC-W5**

STEREO PRE AMPLIFIER

MODEL **UC-A5**

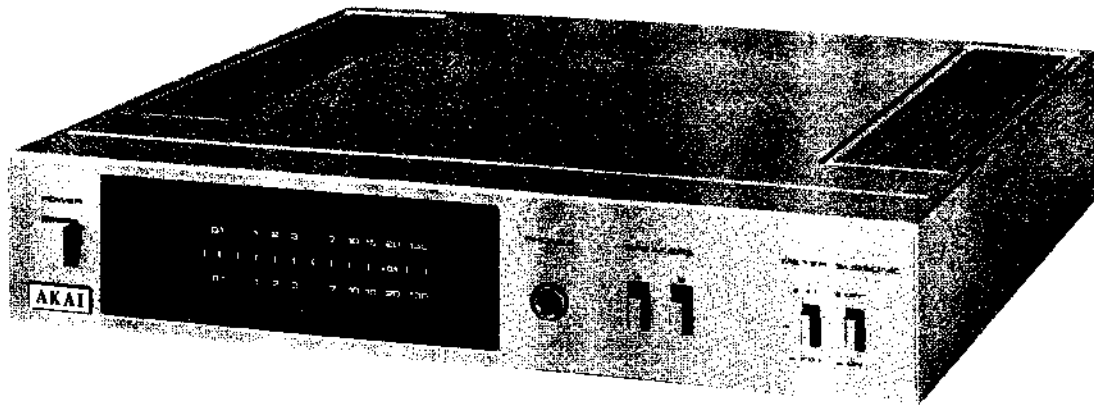

UC-W5

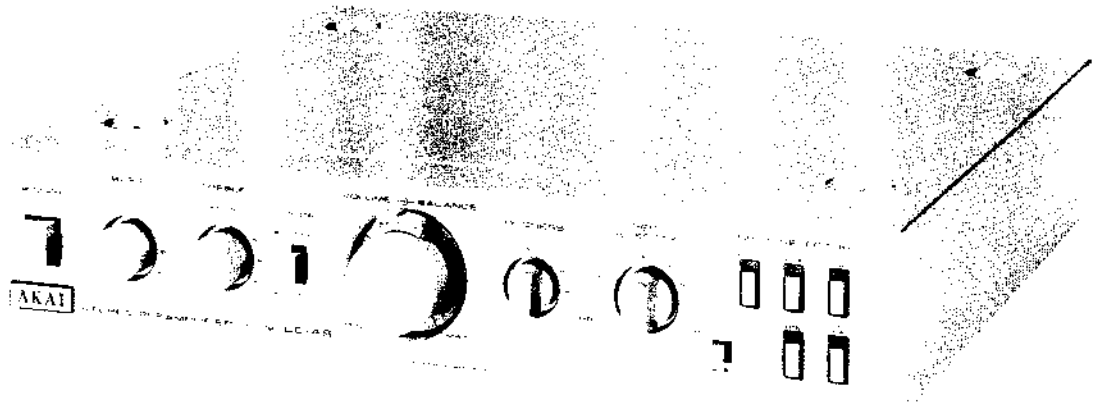

UC-A5

TABLE OF CONTENTS

SECTION 1	MODEL UC-A5	3
SECTION 2	MODEL UC-W5	13
SECTION 3	PARTS LIST	37
SECTION 4	SCHEMATIC DIAGRAM	54

SECTION 1
STEREO PRE AMPLIFIER

MODEL **UC-A5**

ALSO APPLICABLE TO BLACK PANEL MODEL

TABLE OF CONTENTS

I.	TECHNICAL DATA	4
II.	DISMANTLING OF UNIT	5
III.	CONTROLS	6
IV.	PRINCIPAL PARTS LOCATION	7
V.	VOLTAGE CONVERSION	8
VI.	ADJUSTMENT	9
VII.	CLASSIFICATION OF VARIOUS P.C. BOARDS	10
	1. P.C. BOARD TITLE AND IDENTIFICATION NUMBERS	10
	2. COMPOSITION OF VARIOUS P.C. BOARDS	11

I. TECHNICAL DATA

INPUT SENSITIVITY/IMPEDANCE/ SIGNAL TO NOISE RATIO (IHF "A")	
PHONO (MM)	3 mV/47 kohms/82 dB
(MC)	0.08 mV/10 ohms/70 dB
TUNER	150 mV/100 kohms/102 dB
TAPE PLAY 1/2	150 mV/100 kohms/102 dB
OUTPUT LEVEL/IMPEDANCE	
TAPE REC 1/2	150 mV/600 ohms
PRE OUT	1 V/600 ohms
PHONO MAX. INPUT LEVEL (1 kHz)	
PHONO (MM)	330 mV
(MC)	8 mV
FREQUENCY RESPONSE	
TUNER/AUX	
TAPE PLAY 1 & 2	2 Hz to 100 kHz \pm 1 dB
PHONO (RIAA curve deviation)	30 Hz to 15 kHz \pm 0.2 dB
TOTAL HARMONIC DISTORTION (20 Hz to 20 kHz)	
TUNER/AUX	
TAPE PLAY 1 & 2 (Volume Max.)	0.005% at output 5 V
PHONO (REC OUT)	
REC OUT	0.005% at output 5 V
TONE CONTROL	
BASS	\pm 8 dB at 100 Hz
TREBLE	\pm 8 dB at 10 kHz
LOUDNESS CONTROL	
	at 100 Hz at 10 kHz
	1. 3 dB 1. 2.5 dB
	2. 6 dB 2. 5.0 dB
	3. 9 dB 3. 8 dB
	(Volume Control set at -30 dB)
CHANNEL SEPARATION (AUX)	70 dB (Shorted Circuit)
POWER REQUIREMENTS	100 V, 50/60 Hz for Japan 120 V, 60 Hz for USA and Canada 220 V, 50 Hz for Europe except UK 240 V, 50 Hz for UK and Australia 110 V, 220/240V, 50/60 Hz internally switchable for other countries
POWER CONSUMPTION	U/T, CSA, AAL 20 W JPN 13 W
DIMENSIONS (W x H x D)	280 x 56 x 281 mm (11.0 x 2.2 x 11.1 inch)
WEIGHT	2.6 kg (5.7 lbs)

* For improvements purposes, specifications and design are subject to change without notice.

II. DISMANTLING OF UNIT

In case of trouble, etc. necessitating dismantling, please dismantle in the order shown in the Photographs. Reassemble in reverse order.

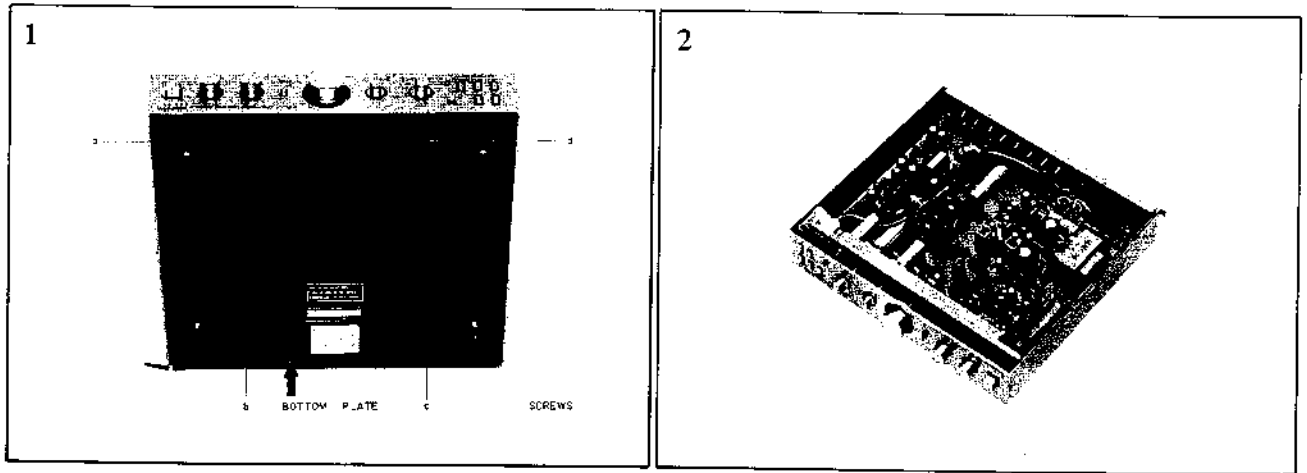

III. CONTROLS

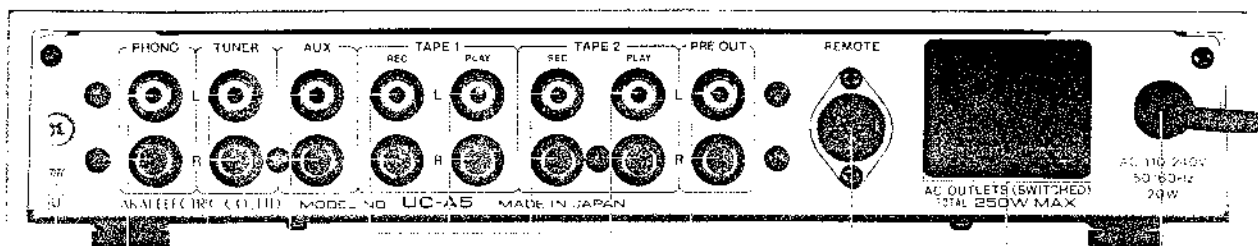
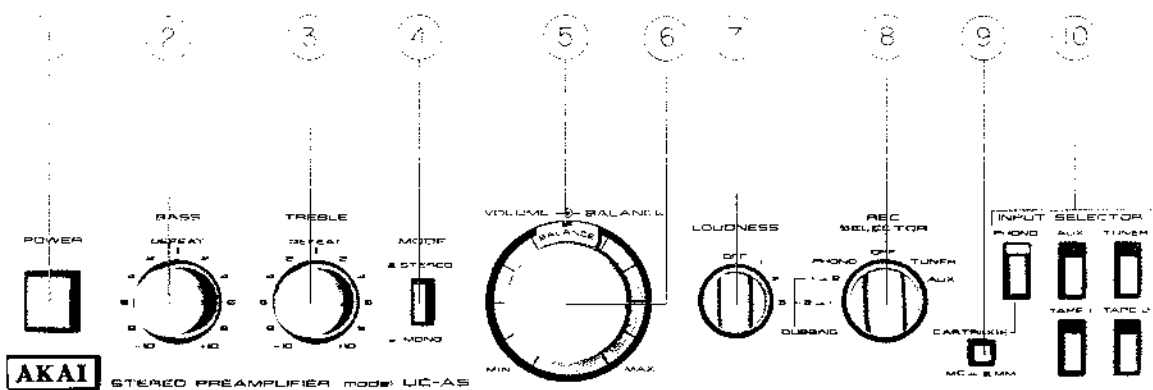

- | | |
|---|---|
| <ol style="list-style-type: none"> 1. POWER SWITCH 2. BASS TONE CONTROL 3. TREBLE TONE CONTROL 4. MODE SELECTOR 5. BALANCE CONTROL 6. VOLUME CONTROL 7. LOUDNESS SWITCH 8. REC SELECTOR 9. CARTRIDGE 10. INPUT SELECTOR | <ol style="list-style-type: none"> 11. GROUND TERMINAL 12. PHONO TERMINALS 13. TUNER TERMINALS 14. AUX TERMINALS 15. TAPE 1 and TAPE 2 TERMINALS 16. PRE OUT TERMINALS (OUTLINE) 17. REMOTE CONTROL 18. AC OUTLETS 19. AC POWER INPUT CORD OR INLET <p>(Some of these are not equipped with the feature)</p> |
|---|---|

IV. PRINCIPAL PARTS LOCATION

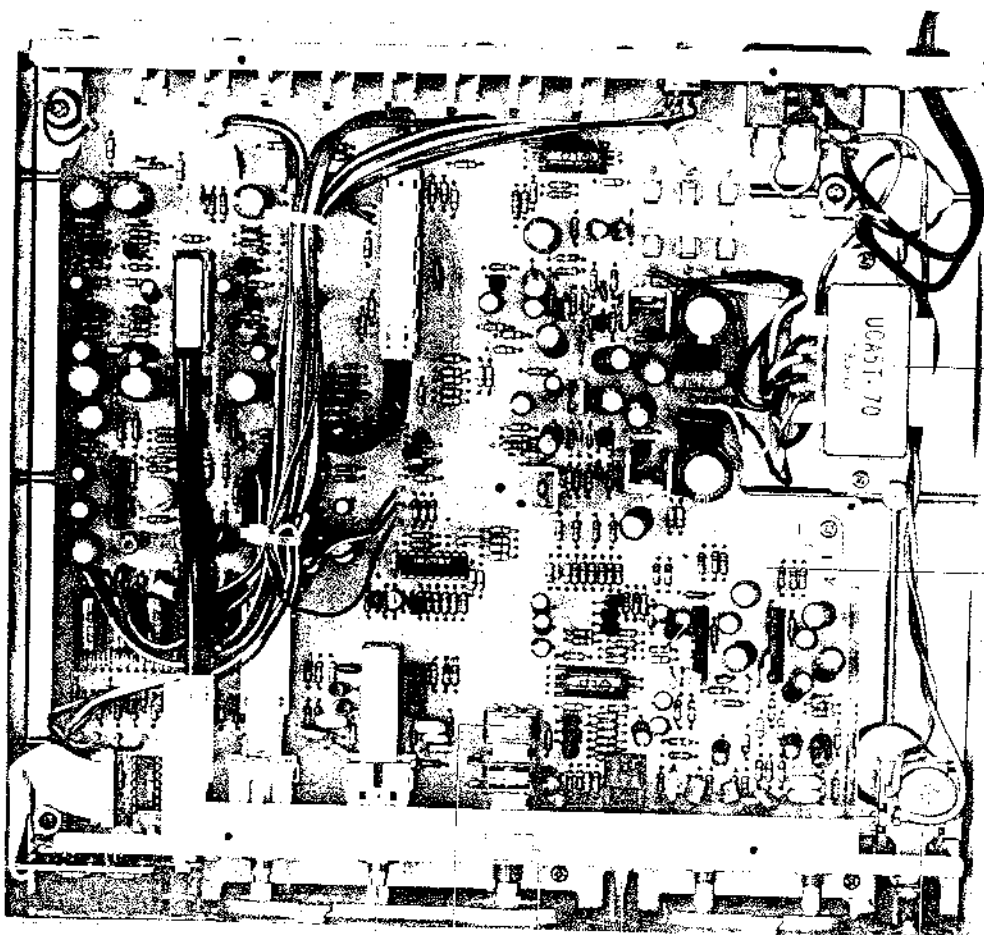

POWER
TRANSFORMER
T-90
U0651-70

SEE FIG.
U0651-70

Fig. 1. Power Unit

V. VOLTAGE CONVERSION

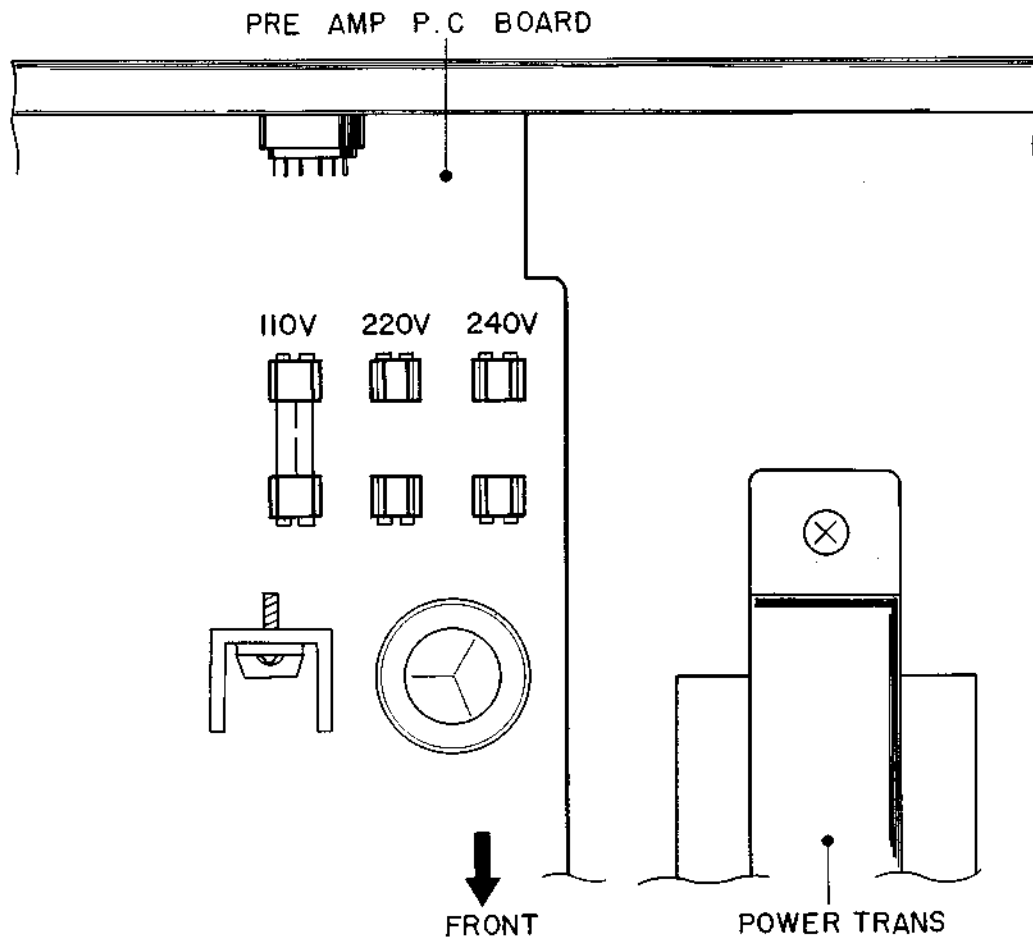

Fig. 3 Voltage Conversion (U/T Model)

1. U/T Model (Refer to Fig. 3)

- 1) Switch OFF power and remove power cord from mains supply.
- 2) Loosen holding screws and remove bottom panel.
- 3) Remove existing Line Voltage Fuse and insert required Line Voltage Fuse in the proper fuse holder.
110 V : 500 mA
220 V : 250 mA
240 V : 250 mA

2. Models other than U/T

No voltage conversion.

VI. ADJUSTMENT

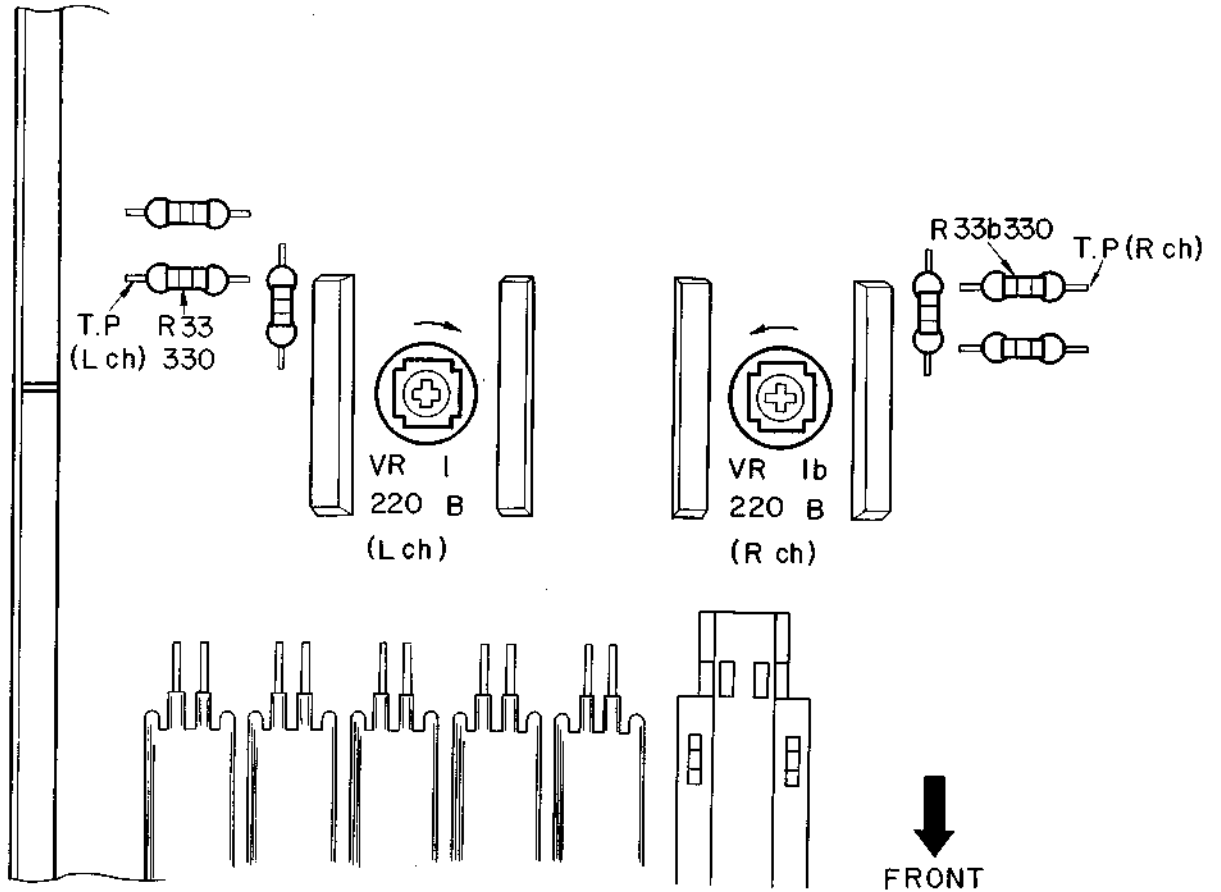

Fig. 4 Adjustment Points

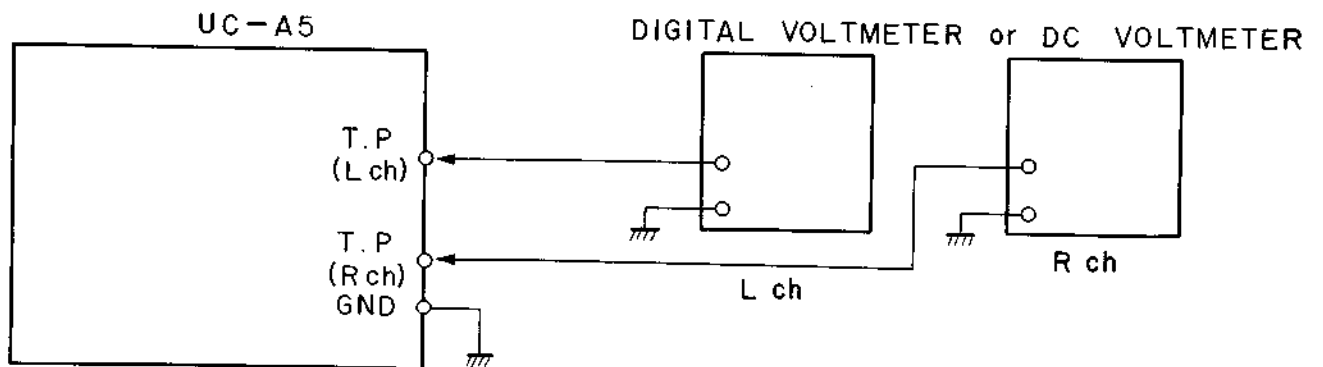

Fig. 5 Instrument Connections

1. CENTER OFF-SET VOLTAGE ADJUSTMENT (Refer to Figs. 4, 5)

Connect the Digital Voltmeter or DC Voltmeter between T.P and Ground. Adjust the VR 1 (220 B) so that Voltmeter reading is 0 ± 50 mV.

VII. CLASSIFICATION OF VARIOUS P.C BOARDS

1. P.C BOARD TITLE AND IDENTIFICATION NUMBERS

P.C Board Title	P.C Board Number
Pre Amp P.C Board	UCA-5001
Input P.C Board	UCA-5002

2. COMPOSITION OF VARIOUS P.C BOARDS

PRE AMP P.C BOARD UCA-5001 (2ED) and INPUT P.C BOARD UCA-5002

WARNING: ALL REPLACEMENT PARTS SHOULD BE IDENTICAL TO THE ORIGINAL PARTS. IF A DIFFERENT PART IS USED, THE OPERATOR SHOULD BE ADVISED. RECOMMENDED PARTS ARE LISTED IN THE PARTS LIST. MAINTENANCE PERSONNEL SHOULD BE ADVISED OF THE LOCATION OF ALL COMPONENTS AND THE LOCATION OF ALL PARTS. THE PARTS LIST IS A GUIDE ONLY. IT IS NOT A SUBSTITUTE FOR THE ORIGINAL PARTS LIST.

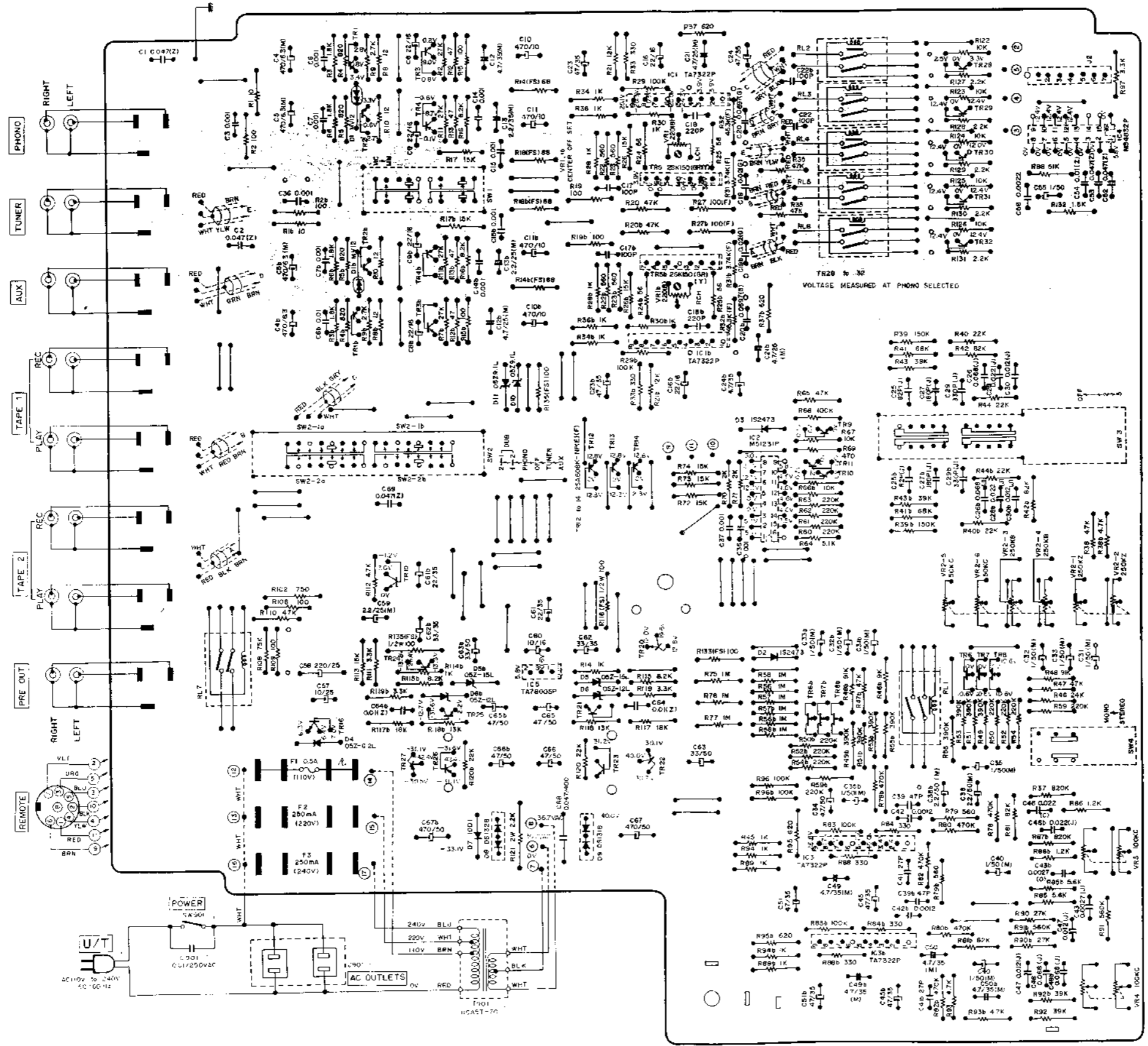

PRE AMP P.C BOARD UCA-5001

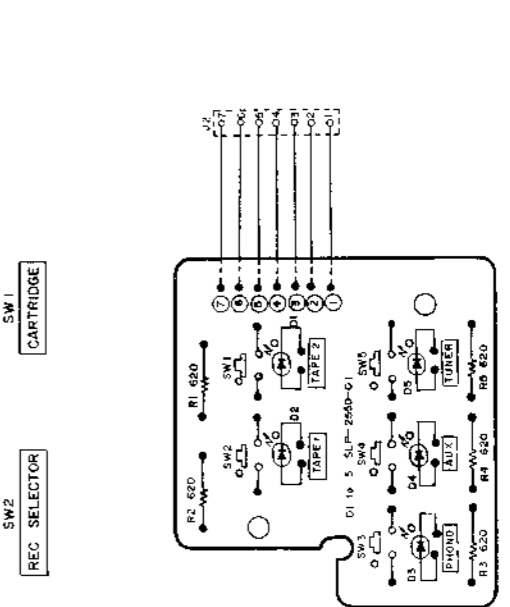

INPUT P.C BOARD UCA-5002

- SW 1 CARTRIDGE
- SW 2 REC SELECTOR
- LOUDNESS
- BALANCE
- VOLUME
- MODE
- TREBLE
- BASS

- 25D612K
- 25B560 250438
- D.C.S 25K30A
- P.C.B 25A608K-NP 25A970 25C3870 25C388K-NP 25C2240
- 25B507AL 250313AL

*TR 4 25A87C16H-GL
 TR 1, 1 25C2240Y100R1
 TR 2, 3 25K204Y110P
 TR 3, 4 12005Y100R1
 TR 4, 5 12005Y100R1
 TR 6 25D436C10F
 TR 7, 8 25D612K10F
 TR 9 25C313AL100R1
 TR 10 25B560C10F
 TR 11 25A608K-NP100R1
 TR 12 25B507AL100R1

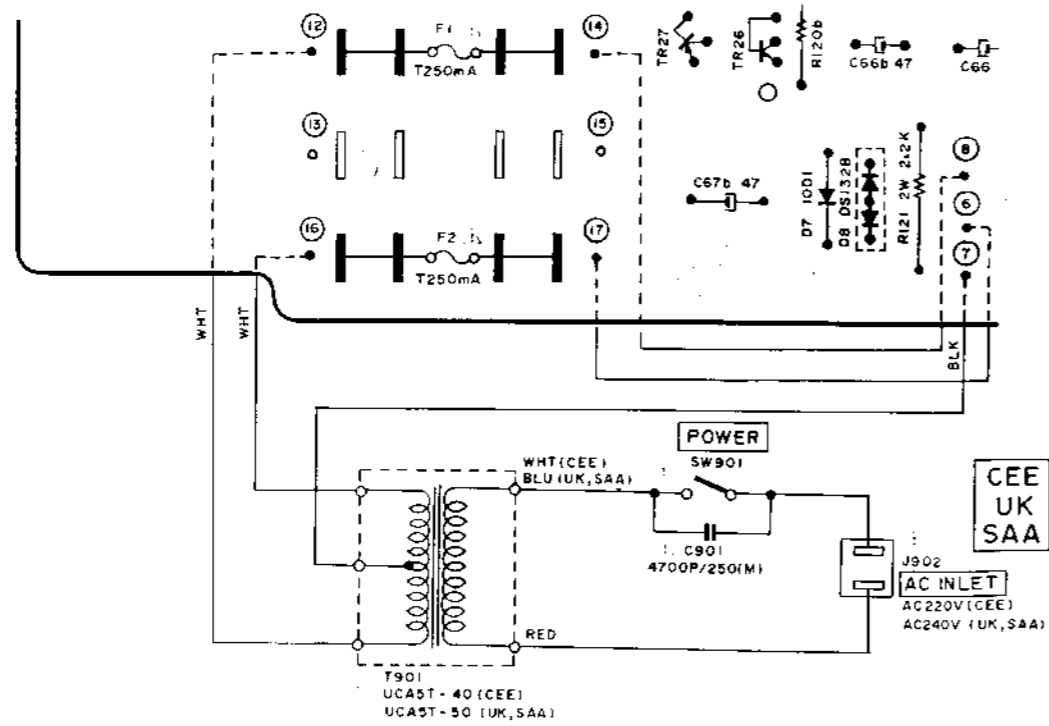
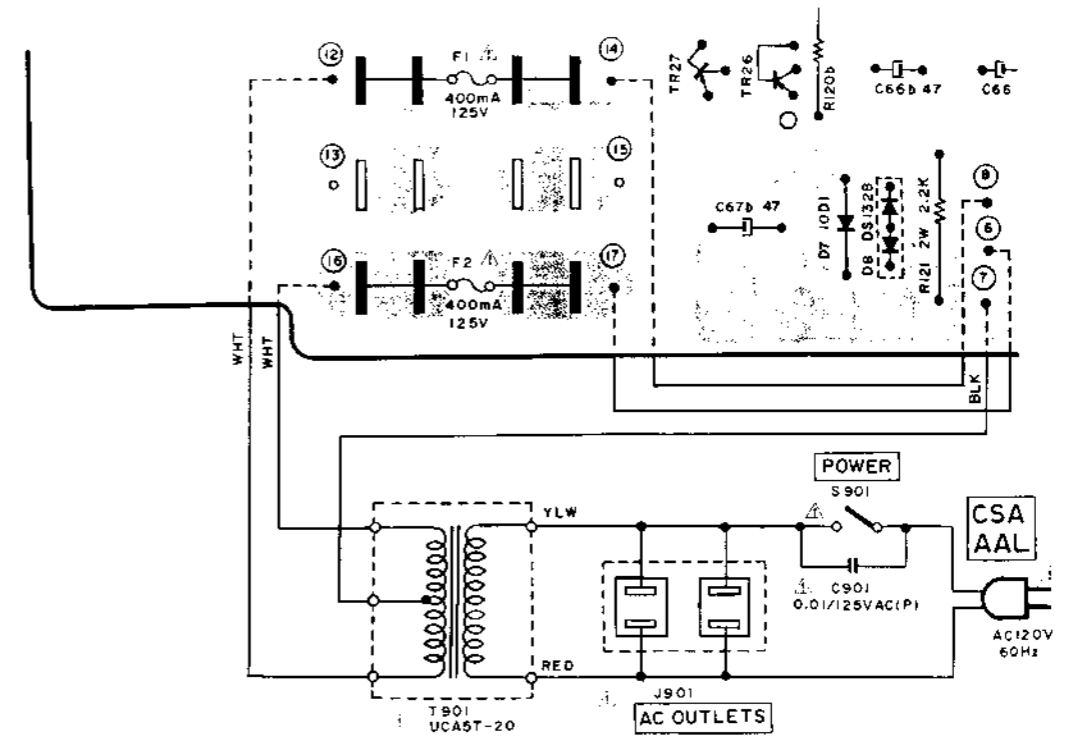
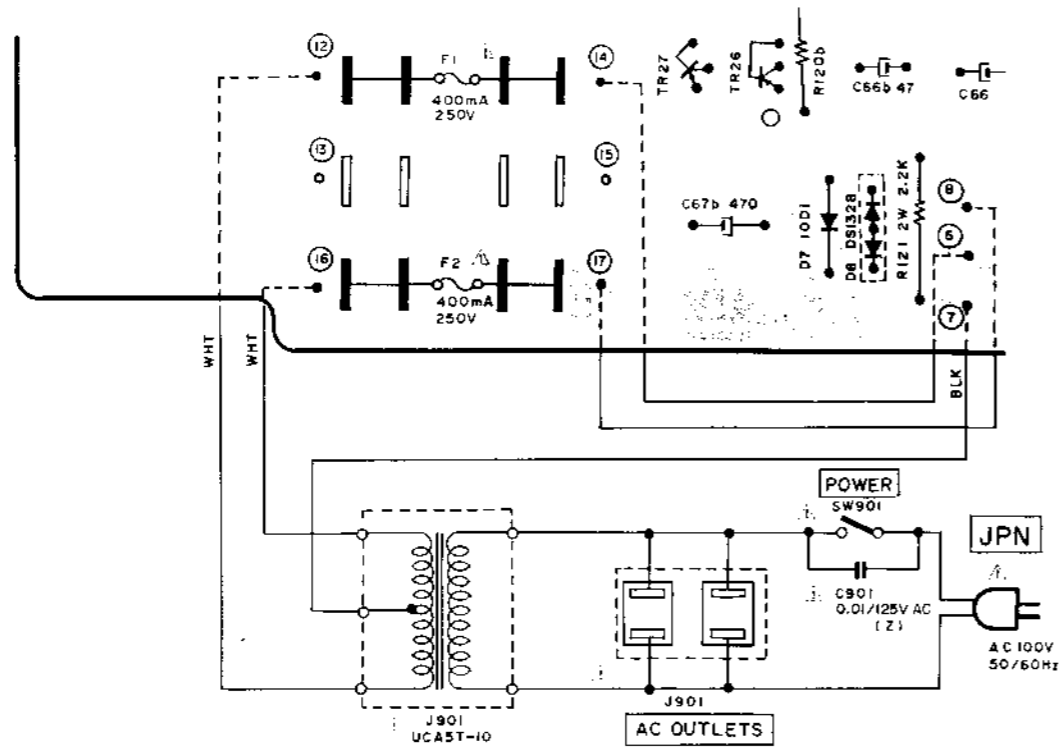

WARNING: TO PREVENT SAFETY HAZARD, LOW VOLTAGE SUPPLY SHOULD BE USED TO REPLACE SAFETY COMPONENTS. ALWAYS FOLLOW THE RECOMMENDED WIRING.
 CAUTION: ALWAYS DISCONNECT THE POWER SUPPLY FROM THE AC INLET BEFORE ANY MAINTENANCE OR REPAIR WORK. ALWAYS USE THE CORRECT WIRING AND THE CORRECT WIRE GAUGE FOR THE SUPPLY VOLTAGE AND CURRENT RATING. ALWAYS USE THE CORRECT WIRING AND THE CORRECT WIRE GAUGE FOR THE SUPPLY VOLTAGE AND CURRENT RATING.

SECTION 2

DC STEREO POWER AMPLIFIER

MODEL **UC-W5**

ALSO APPLICABLE TO BLACK PANEL MODEL

TABLE OF CONTENTS

I.	TECHNICAL DATA	14
II.	DISMANTLING OF UNIT	15
III.	CONTROLS	16
IV.	PRINCIPAL PARTS LOCATION	17
V.	VOLTAGE CONVERSION	18
VI.	OPERATION OF PULSE POWER CIRCUIT	19
VII.	ADJUSTMENT	26
VIII.	CLASSIFICATION OF VARIOUS P.C BOARDS	28
	1. P.C BOARD TITLES AND IDENTIFICATION NUMBERS	28
	2. COMPOSITION OF VARIOUS P.C BOARDS	29

I. TECHNICAL DATA

INPUT SENSITIVITY/IMPEDANCE MAIN IN	1 V/47 kohms
RATED POWER OUTPUT 2-CHANNELS DRIVEN	35 watts per channel, minimum RMS, at 8 ohms from 20 to 20,000 Hz with no more than 0.01% T.H.D.
TOTAL HARMONIC DISTORTION	0.01% at rated power output
INTERMODULATION DISTORTION	0.01% at rated power output
POWER BANDWIDTH (IHF)	6 Hz to 60 kHz/8 ohms (T.H.D.: 0.05%)
SIGNAL TO NOISE RATIO (IHF "A")	115 dB
RESIDUAL NOISE (IHF "A" ohms)	Less than 0.05 mV
DAMPING FACTOR	More than 100 (1 kHz, 8 ohms)
OUTPUT (Required load impedance) SPEAKERS PHONES	A, B (4 to 16 ohms)/A + B (8 to 16 ohms) to 8 ohms
FREQUENCY RESPONSE SUBSONIC FILTER	DC to 100 kohms, +0 dB, -0.5 dB 6 dB/oct at 18 Hz
METER x 0.1 x 1	0.01 to 13 W (at 8 ohms) 0.1 to 130 W (at 8 ohms)
POWER REQUIREMENTS	100V, 50/60 Hz for Japan 120V, 60 Hz for USA and Canada 220V, 50 Hz for Europe except UK 240V, 50 Hz for UK and Australia 110V - 120/220/240V, 50/60 Hz internally switchable for other countries
POWER CONSUMPTION	U/T, CSA, AAL 160W, JPN 95W
DIMENSIONS	280 (W) x 56 (H) x 284 (D) mm (11.0 x 2.2 x 11.2 inches)
WEIGHT	3.4 kg (7.5 lbs)

* For improvements purposes, specifications and design are subject to change without notice.

II. DISMANTLING OF UNIT

In case of trouble, etc. necessitating dismantling, please dismantle in the order shown in the Photographs. Reassembly in reverse order.

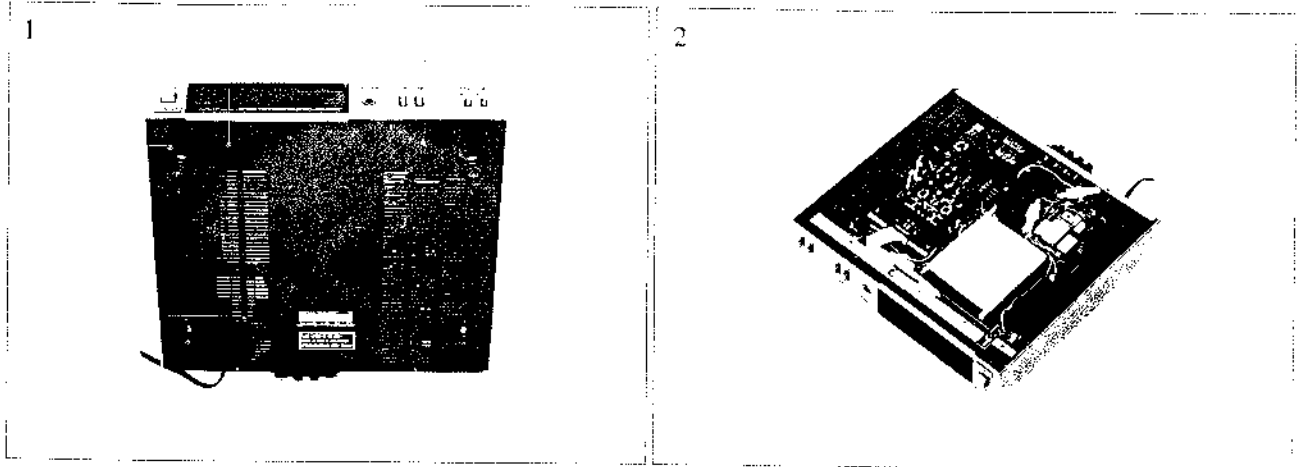

III. CONTROLS

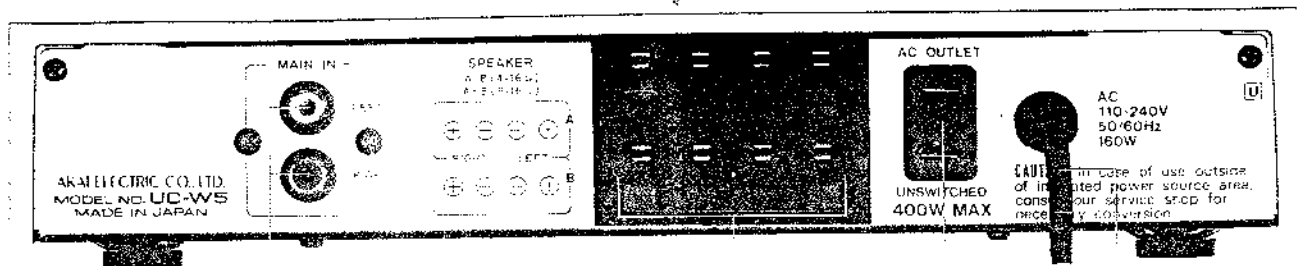
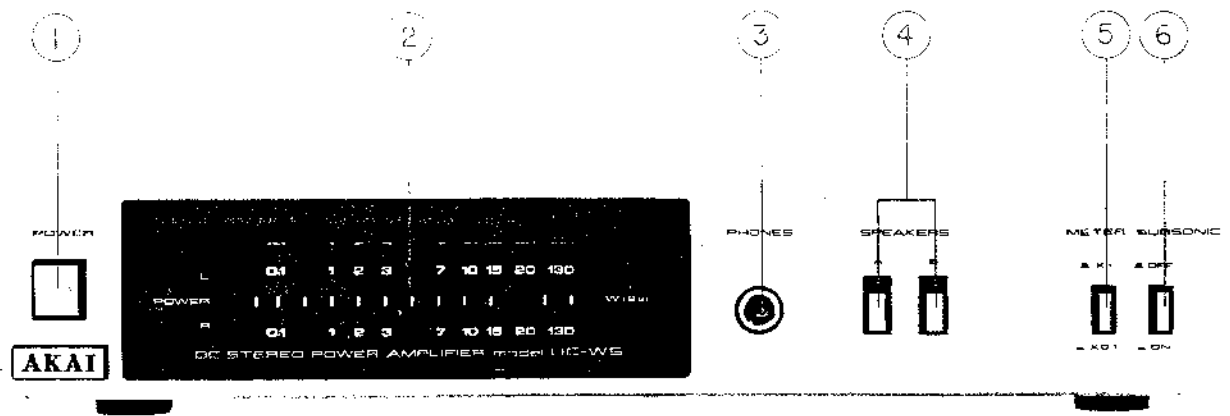

- | | |
|---|--|
| <ol style="list-style-type: none"> 1. POWER SWITCH 2. POWER METER 3. PHONES JACK 4. SPEAKERS SWITCHES 5. METER SWITCH 6. SUBSONIC FILTER SWITCH | <ol style="list-style-type: none"> 7. MAIN IN TERMINALS (INPUT) 8. SPEAKER TERMINALS 9. AC OUTLET (UNSWITCHED)
(Some models are not equipped with this facility) 10. AC POWER INPUT CORD
(Some models are equipped with an AC INLET) |
|---|--|

IV. PRINCIPAL PARTS LOCATION

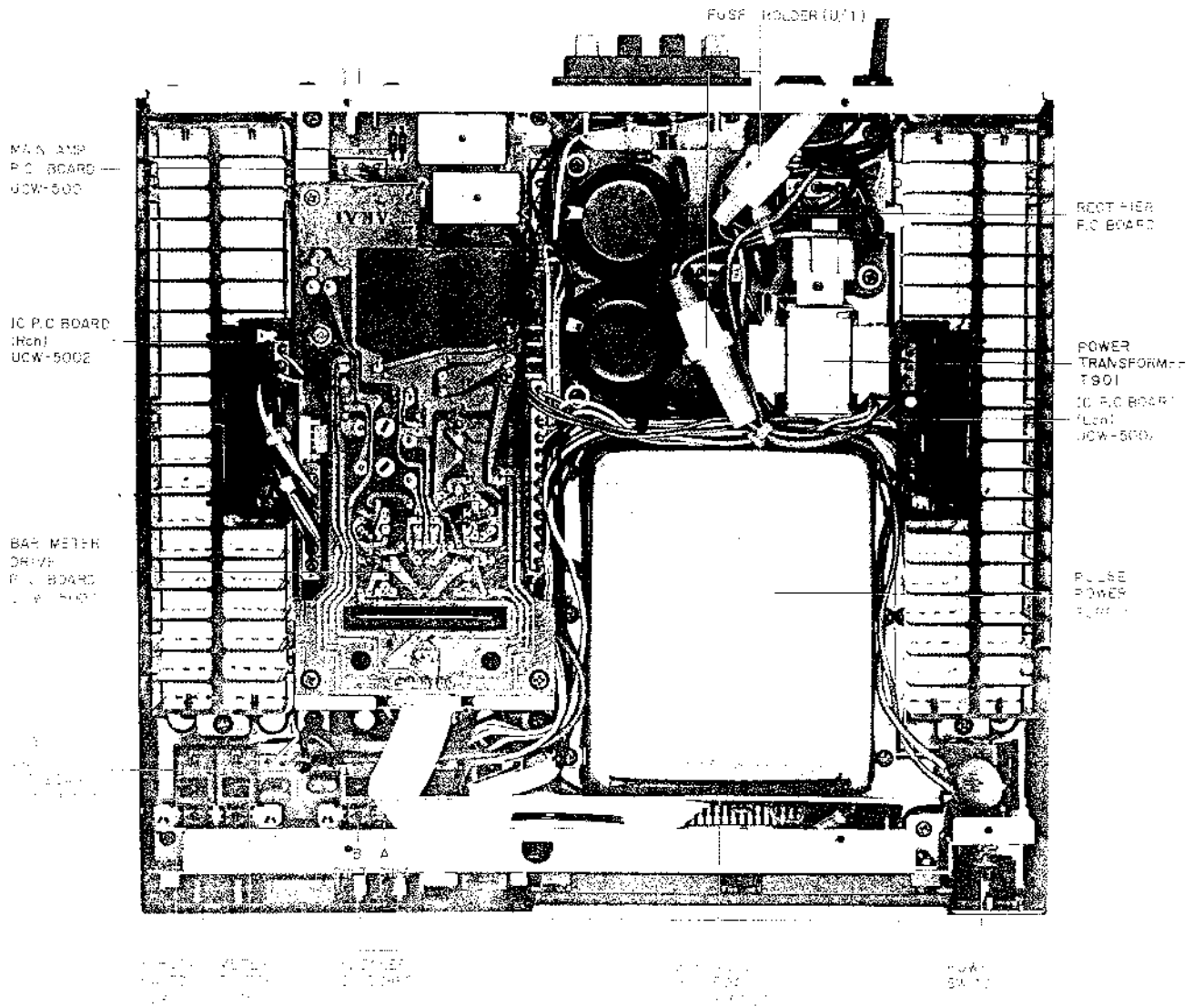

Fig. 1 Rear View

V. VOLTAGE CONVERSION

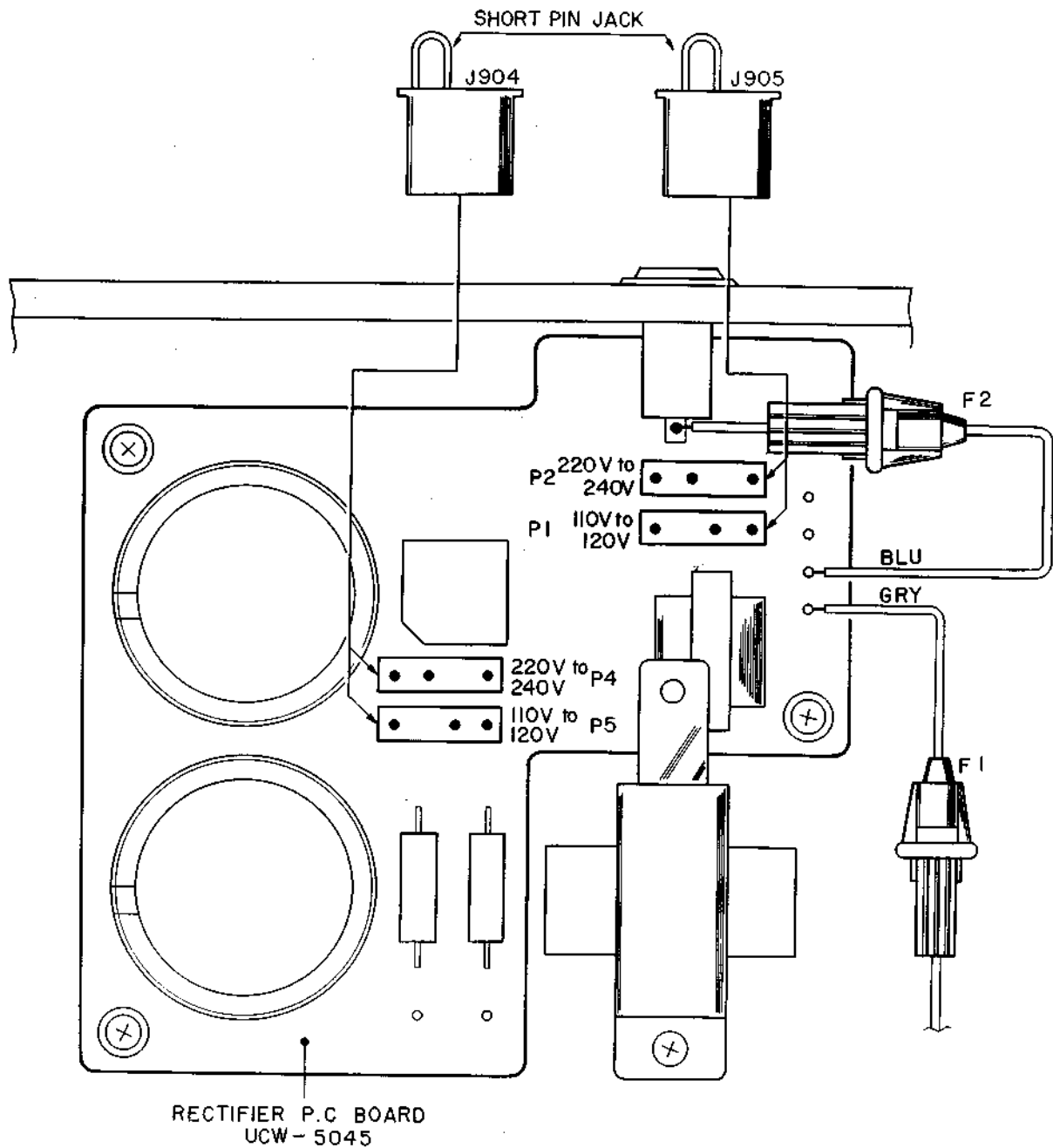

Fig. 3 Voltage Conversion (U/T Model)

1. U/T Model (Refer to Fig. 3)

- 1) Switch OFF the power supply and remove the power cord from the mains supply.
- 2) Loosen the holding screws and remove the bottom panel.
- 3) Insert the short pin jacks J904 and J905 (Refer to Fig. 3).
- 4) Change the fuse (F 1, F 2) : 4 A for 110 V to 120 V and 2 A for 220 V to 240 V.

2. Models other than U/T

No voltage conversion.

VI. OPERATION OF PULSE POWER CIRCUIT

The Pulse Power Circuit is composed of a high-voltage rectifier circuit, oscillator starting circuit, inverter circuit (blocking oscillator circuit), transformer circuit, rectifier circuit and smoothing circuit as shown below.

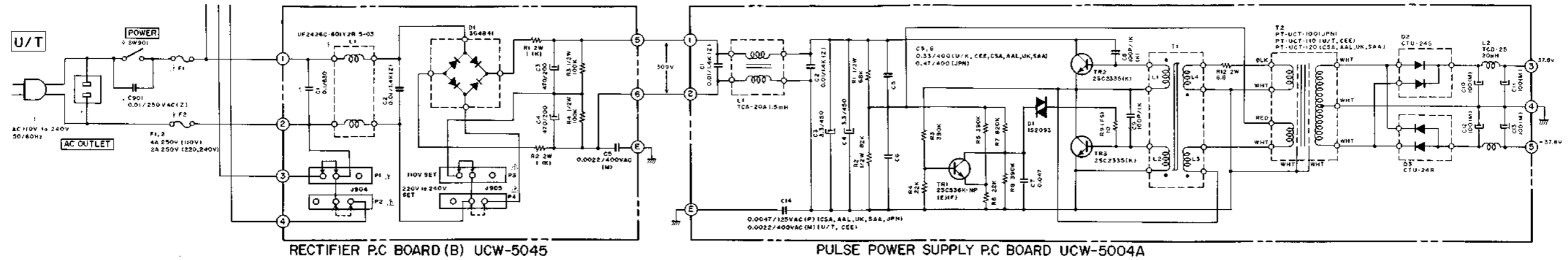
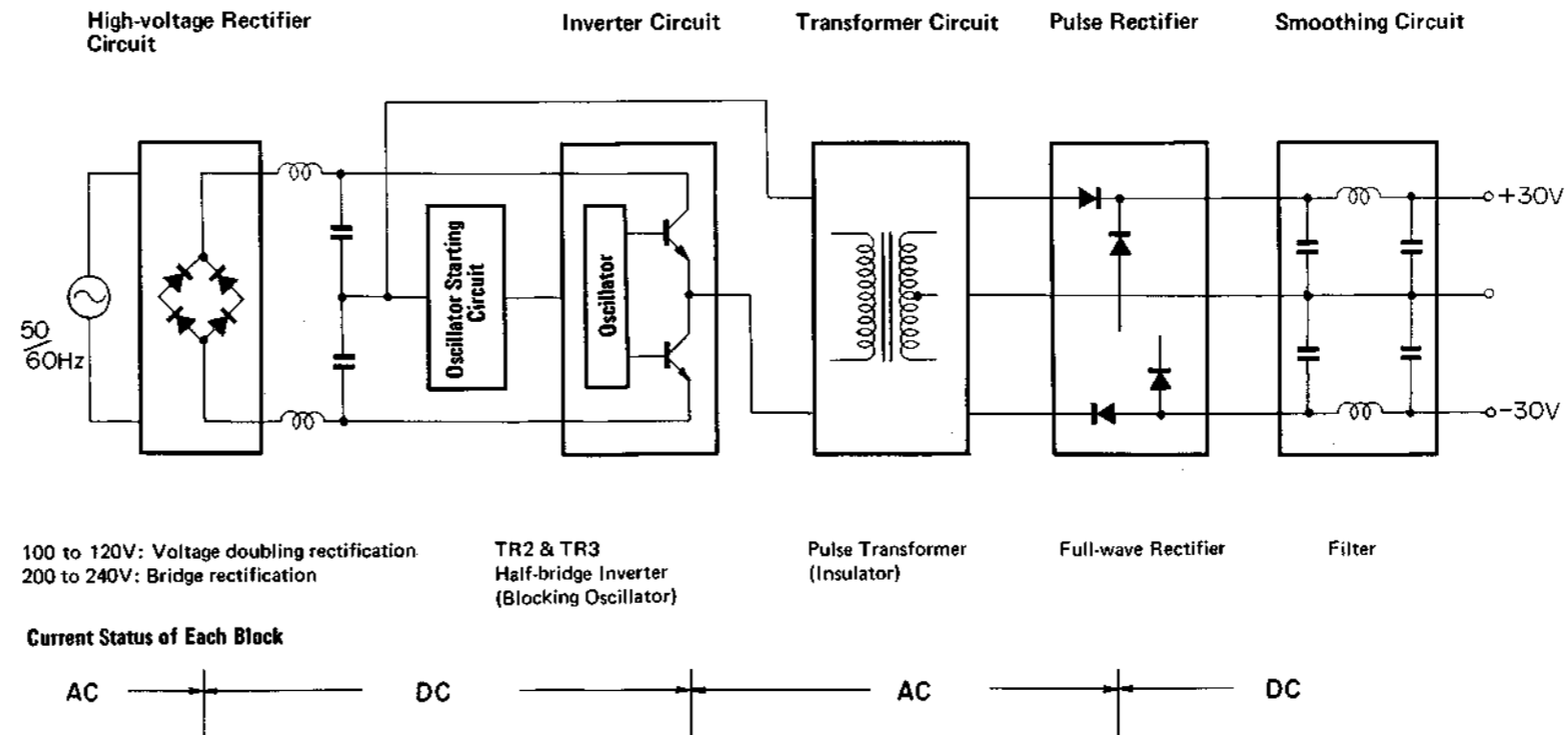

Fig. 4 Schematic diagram for power section

1. HIGH-VOLTAGE RECTIFIER CIRCUIT

Either the voltage doubling rectifier system, or the bridge rectifier system is selected according to the difference in the power supply voltage. That is, voltage doubling rectification is adopted for input voltage of 100 to 120V (for the U.S. Canada and Japan), while bridge rectification is adopted for those of 220 to 240V (for Europe, etc.), to obtain a DC voltage of approximately 300V.



Voltage and Current Characteristics

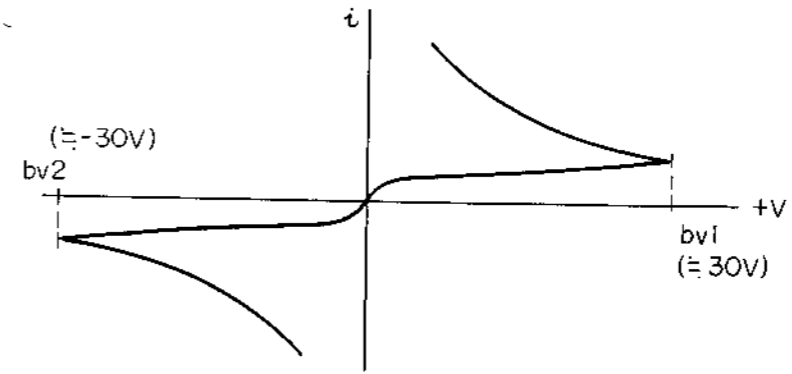

Fig. 6 Diode characteristics

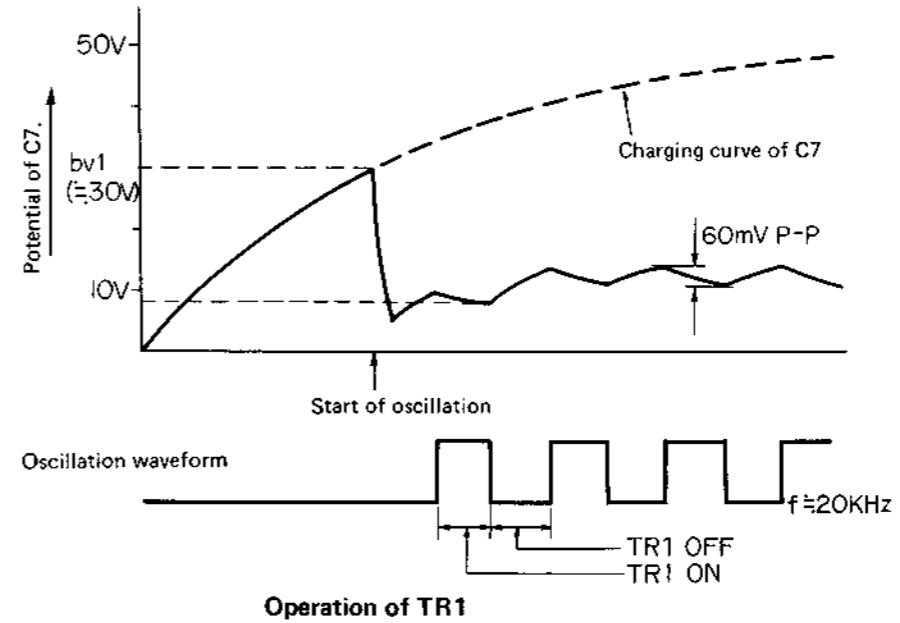

Fig. 7 Operation of TR1

2. OSCILLATOR STARTING CIRCUIT

At power switch-on, this circuit creates an initial pulse which starts the inverter circuit of the next stage. D1 is a double-directional trigger diode that quickly turns on when the voltage at both ends exceeds the breakover voltage (approx. 30V) as breakdown voltage flows through it. When the potential of C7 is raised to about 30V by switching-on the power, it will cause a positive trigger pulse to be applied to the base of TR3, thereby starting oscillation.

During oscillation, 20 kHz and 300 Vp-p square waves will appear at the intersecting point of TR2 and TR3, so that TR1 will repeat the 20 kHz switching operation. That is, the potential of C7 will be discharged when it is turned on, whereas C7 will be charged when turned off. For this reason, the potential of C7 will not reach the break-over voltage of D1, as can be seen from Fig. 7, so that D1 will be in a high-impedance state. And the operations of these circuits are absolutely unrelated to those of other circuits.

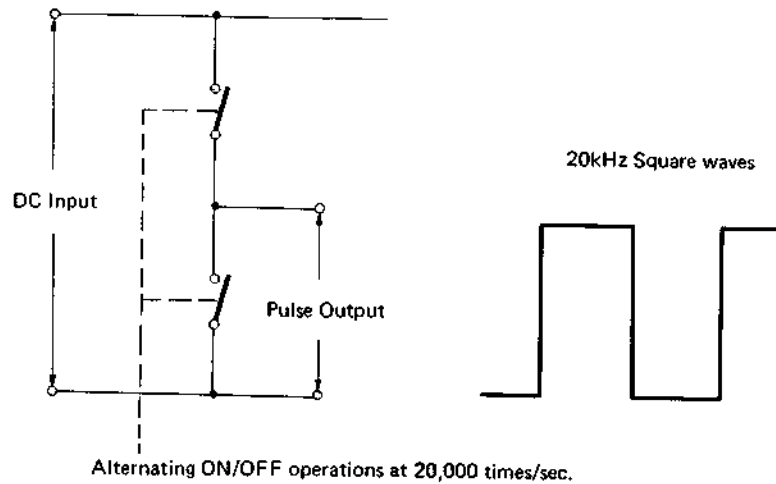

Fig. 8 Principle diagram of inverter

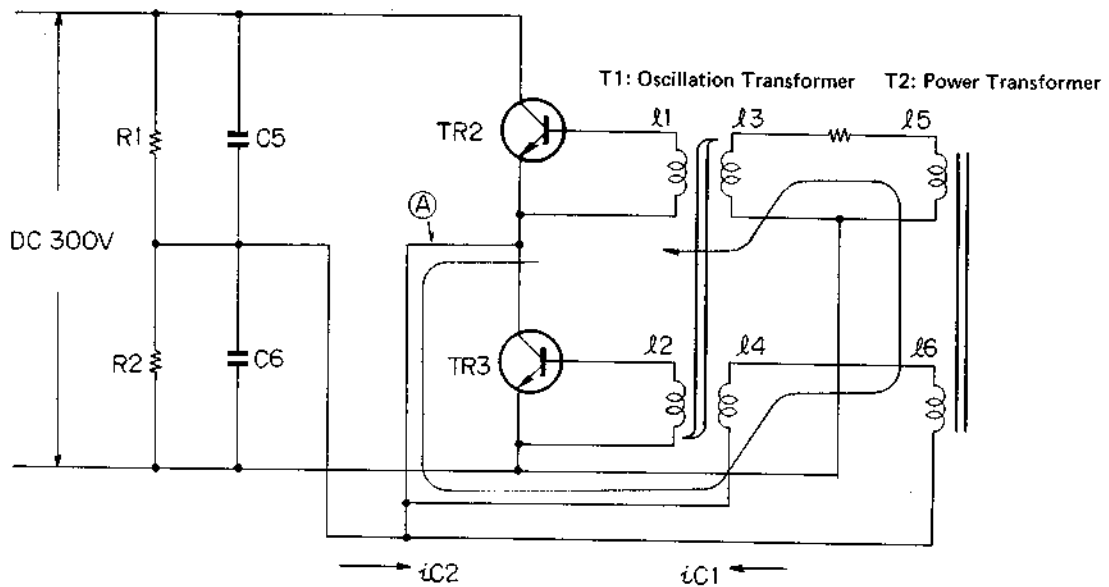

Fig. 9 Basic schematic diagram

3. INVERTER CIRCUIT (BLOCKING OSCILLATOR CIRCUIT)

This circuit functions to convert DC voltage into pulsating alternating voltage. By turning on TR2 and TR3 alternately, it causes pulse (square waves) to be generated at the intersecting point of TR2 and TR3. The 300V is divided into 150V and applied to the mid-point of C5 (R1) and C6 (R2). (This will be referred as the mid-point hereinafter.)

First, a trigger pulse is applied to the base of TR3 by the oscillator starting circuit. This causes TR3 to turn on and a collector current i_{C2} to flow in from the mid-point. Since this current flows from l6 to l4, current will also be induced in l5 and l3. Therefore, this current will be fed back to coil l2 of TR3's base, following flux variations in T1 (Troidal trans-

former) which accompany current variations in l3. As this loop is formed in a direction that realizes positive feedback, collector current i_{C2} will continue to increase with the increase in the base current of TR3. As a result, the current flowing through l3 will also continue to increase, causing the flux density to become higher and to eventually reach saturation after the passage of a certain time. When the flux saturates so that the flux no longer varies, the l3 to l2 loop will be disconnected as a result. However, even after this positive feedback loop has been disconnected, collector current i_{C2} will continue to flow for a while, due to the action of the counter electromotive force that works in the direction that permits continued current flow. But, soon, the collector current will start to decrease rapidly.

TR2 ON (TR3 OFF) Period

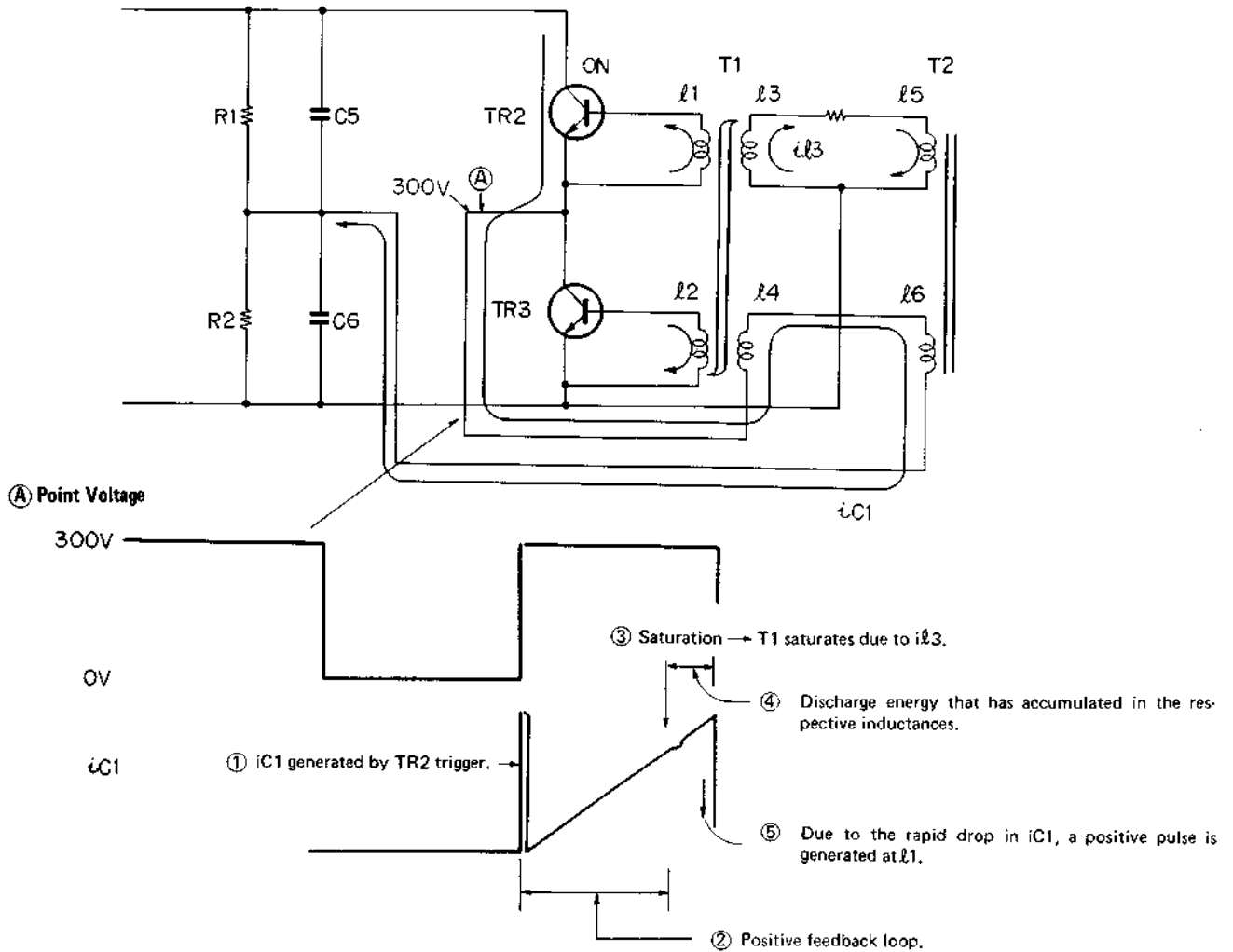

Fig. 10 TR2 turn-on period

During the above process, TR3 will be turned on, while TR2 will be "cut-off". This is because coil $l1$ of TR2's base is wound in a direction opposite to which $l2$ is wound, so that an inverse-direction voltage will be induced for TR2's base-emitter potential V_{BE} . For this reason, the potential of the intersecting point of TR2 and TR3 will become "0"V. When i_{C2} starts to decrease rapidly, the resultant flux variation will cause a positive pulse to be generated at $l1$, which, in turn, will cause TR2 to turn on and TR3 to be cut-off.

Likewise, when the collector (emitter) current i_{C2} flows in the order of $l4$ to $l6$ to mid-point, it will cause a positive feedback loop of $l6$ to $l5$ to $l3$ to $l1$ to be formed, so that a process similar to that just described will take place.

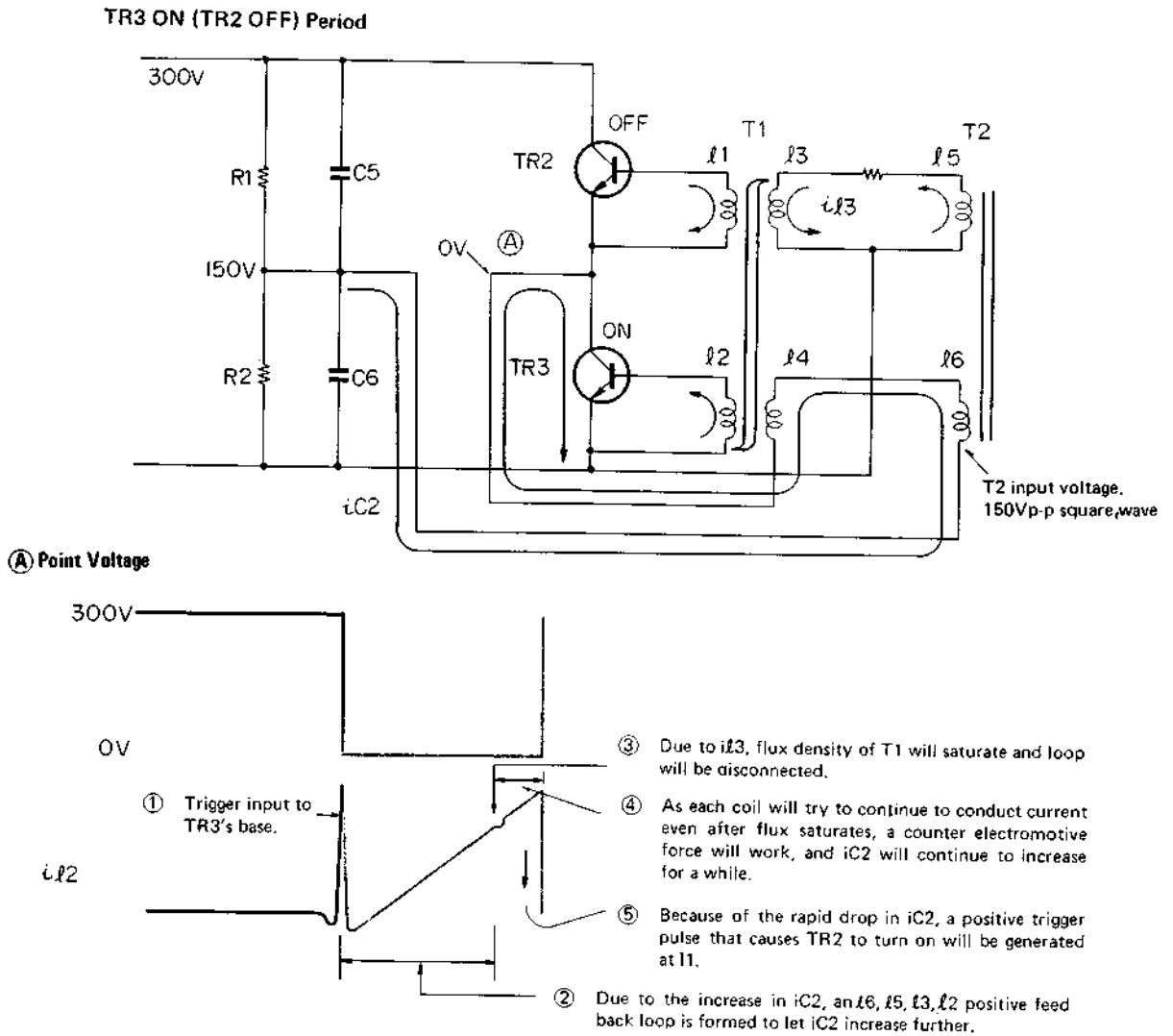

Fig. 11 TR3 turn-on period

In this way, TR2 and TR3 will be alternately turned on again and again, causing square waves to be generated. Fig. 11 gives the waveforms appearing at the respective sections during the serial process.

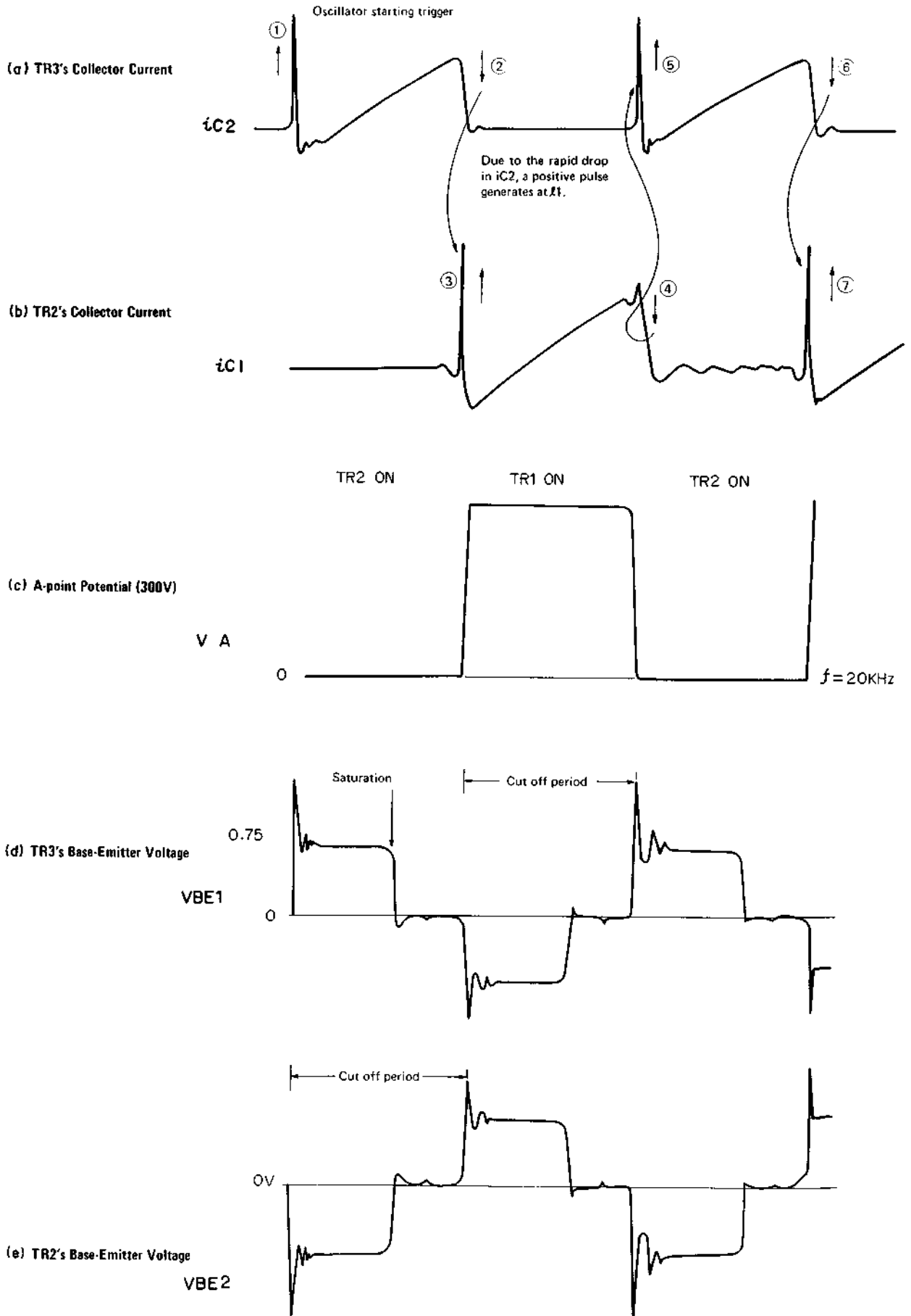

Fig. 12 Summary of waveforms appearing at each section

As shown in (d) and (e), the waveform of the base-emitter voltage of TR2 and TR3 will become "0"V upon saturation of T1's flux. In the meantime, the base current will flow in the direction similar to that before saturation, because of the counter electromotive force.

Meanwhile, by having a negative feedback applied at the high frequency range, the capacitor provided between the collector and base of TR2 and TR3 will function so as to hold down the wave height to an adequate level to prevent the peak values from rising above the maximum ratings of the respective transistors.

The oscillating frequency of this circuit is determined by such factors as the maximum flux density of T1 and the current flowing through ℓ_3 . It is ordinarily designed to be approximately 20kHz.

4. TRANSFORMER CIRCUIT

Although it is based on the same principle as that applied to general power transformers, the core material has been changed into ferrite material from the conventional electrical steel plate material to match the input waveform (square wave of approx. 20kHz). Owing to the high permeability and use of high frequencies, power loss is far less, than with conventional transformers. Therefore, it permits miniaturization of circuitry, which is the advantage of using a pulse power supply.

At the same time, the transformer circuit functions to insulate the secondary-side chassis potential from the AC input potential applied to the prime side.

5. RECTIFIER CIRCUIT

Although this is a full-wave rectifier circuit intended for use with both plus and minus power supplied, it employs first recovery diodes having a quick reverse recovery time (trr) to enable high-efficiency rectification of square waves. Ordinary rectifying diodes cannot be used in this circuit.

6. SMOOTHING CIRCUIT

Because of the high frequencies, it enables direct current having a low ripple factor to be obtained with a small-capacity electrolytic capacitor. Since it has to handle square waves and impulsive triggers, and because of large number of harmonics, the pulse power supply is formed into an LPF (smoothing circuit employing a choke coil. At the same time, to avoid interference caused by radiation and induction of electromagnetic waves, the pulse power circuit, excluding the high-voltage rectifier circuit, is enclosed in a shield case to ensure sufficient shield-off. Packing used for the shield case is made of conductive material if it has been damaged during servicing or for other reasons, it must be replaced with new packing. Otherwise, undesirable radiation from the damaged part may cause noise to generate in other circuits.

VII. ADJUSTMENT

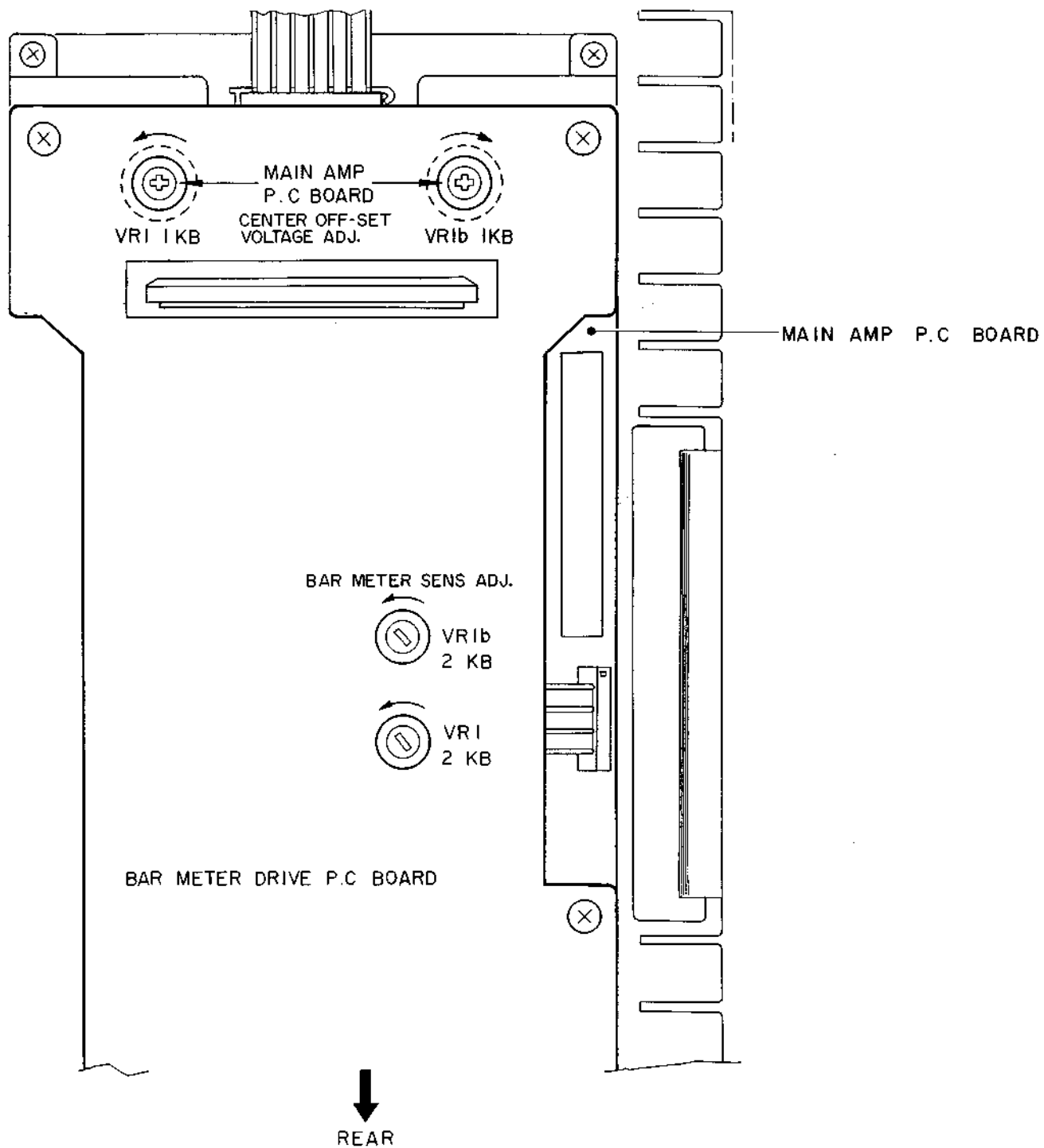

Fig. 13 Adjustment Points

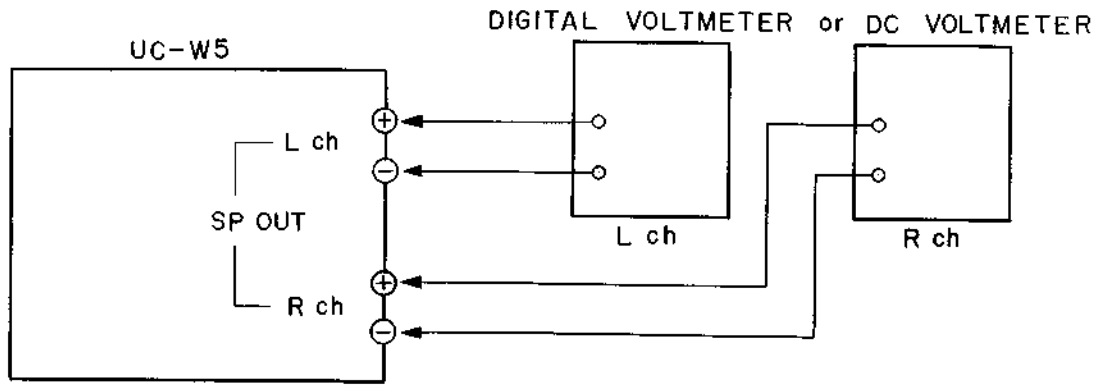

Fig. 14 Instrument Connections

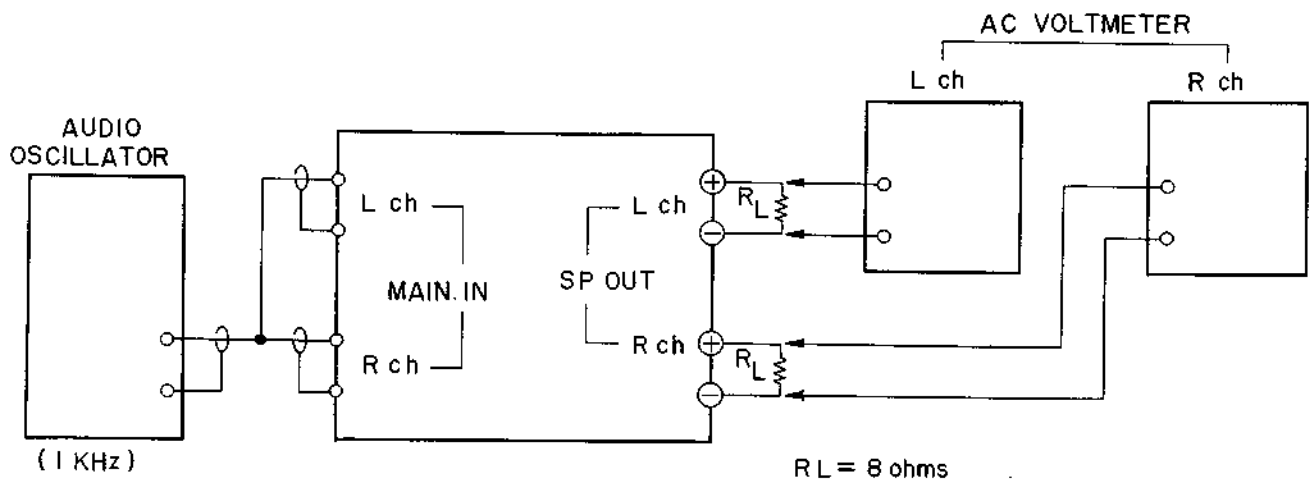

Fig. 15 Instrument Connections

1. CENTER OFF-SET VOLTAGE

ADJUSTMENT (Refer to Figs. 13, 14)

Connect the Digital Voltmeter or DC Voltmeter between SPEAKER terminals.

Adjust the VR1 (L-ch), VR1b (R-ch) on the Main P.C Board so that Voltmeter reads 0 ± 50 mV.

2. BAR METER SENSITIVITY

ADJUSTMENT (Refer to Figs. 13, 15)

Connect load resistors ($R_L = 8$ ohms) to the SPEAKER terminals, and input a sine wave of 1 kHz to the INPUT terminal.

Control the input signal level until the voltmeter connected to both ends of the load read 8.9V.

Under this condition, adjust VR1 (L-ch), VR1b (R-ch) on the Bar Meter Drive P.C Board so that the Bar Meter indicates 10W.

VIII. CLASSIFICATION OF VARIOUS P.C BOARDS

1. P.C BOARD TITLES AND IDENTIFICATION NUMBERS

P.C Board Title	P.C Board Number
Main Amp P.C Board	UCW-5001
IC P.C Board	UCW-5002
Push Switch P.C Board	UCW-5003
Pulse Power Supply P.C Board	UCW-5004A
Bar Meter P.C Board	UCW-5006
Bar Meter Drive P.C Board	UCW-5007
LED P.C Board	UCW-5044
Rectifier P.C Board (U/T)	UCW-5045
Rectifier P.C Board (CEE, UK, SAA)	UCW-5005
Rectifier P.C Board (CSA, AAL, JPN)	UCW-5064

Chart-1

2. COMPOSITION OF VARIOUS P.C BOARDS

1) MAIN AMP P.C BOARD UCW-5001 (2ED)

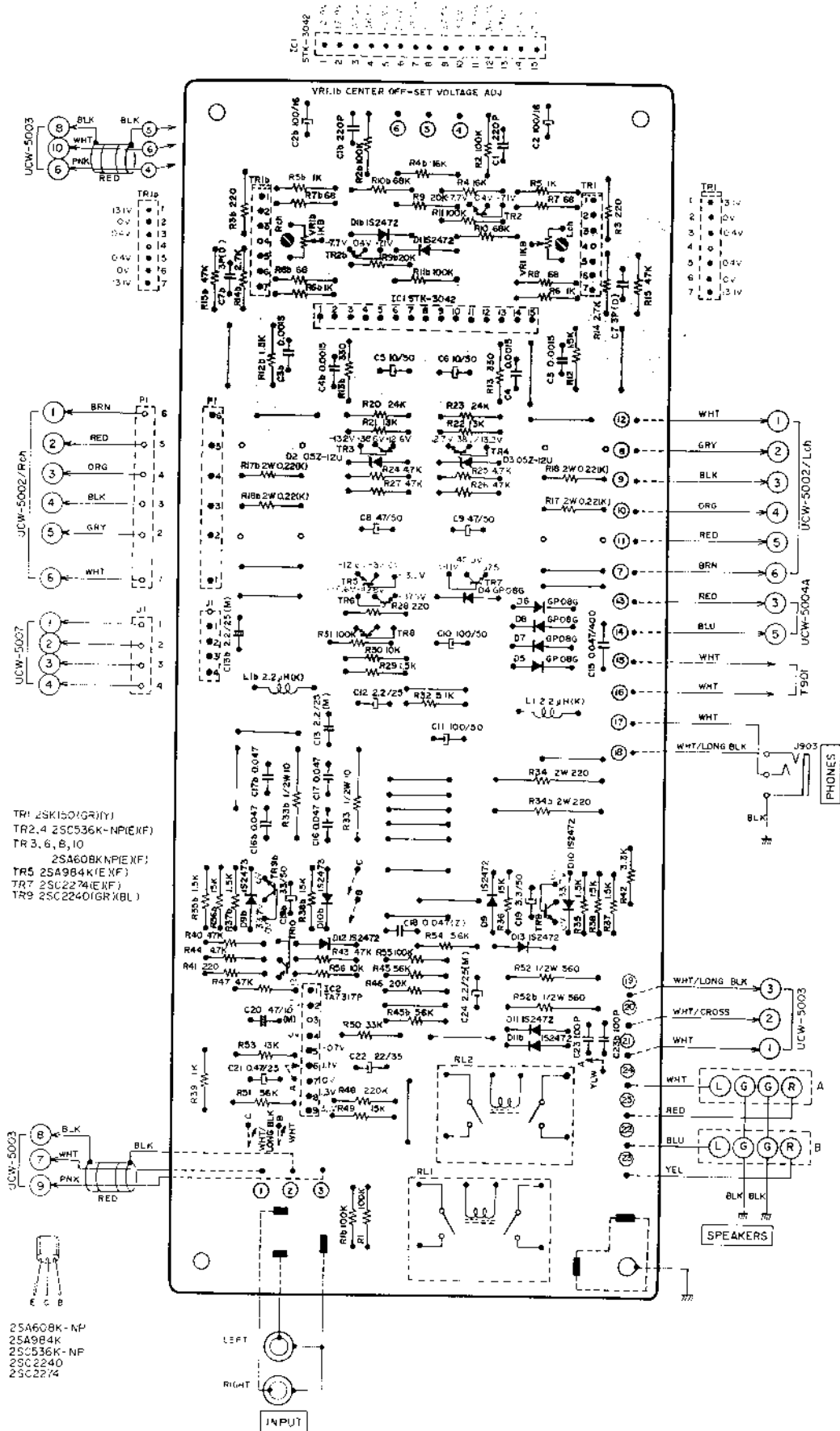

2) IC P.C BOARD (L-CH) UCW-5002

3) IC P.C BOARD (R-CH) UCW-5002

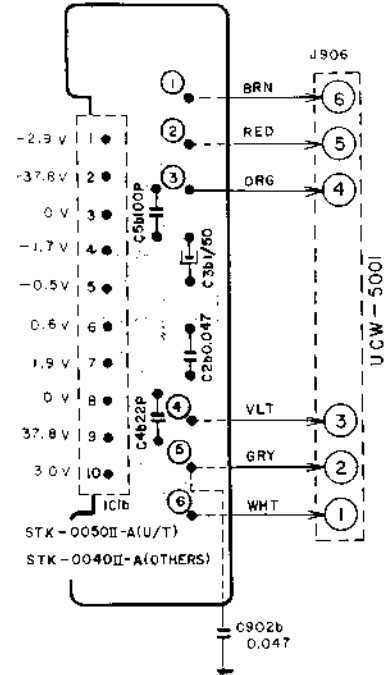
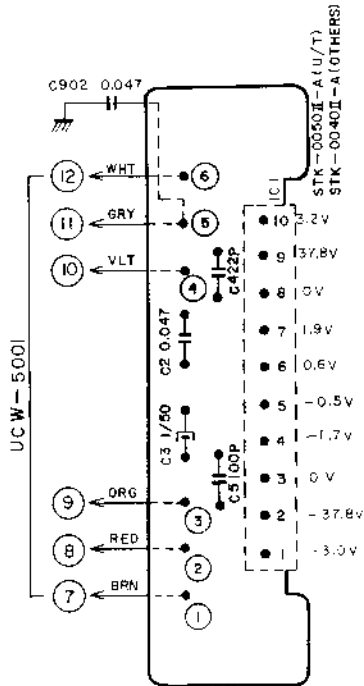

4) PUSH SWITCH P.C BOARD UCW-5003 and LED P.C BOARD UCW-5044

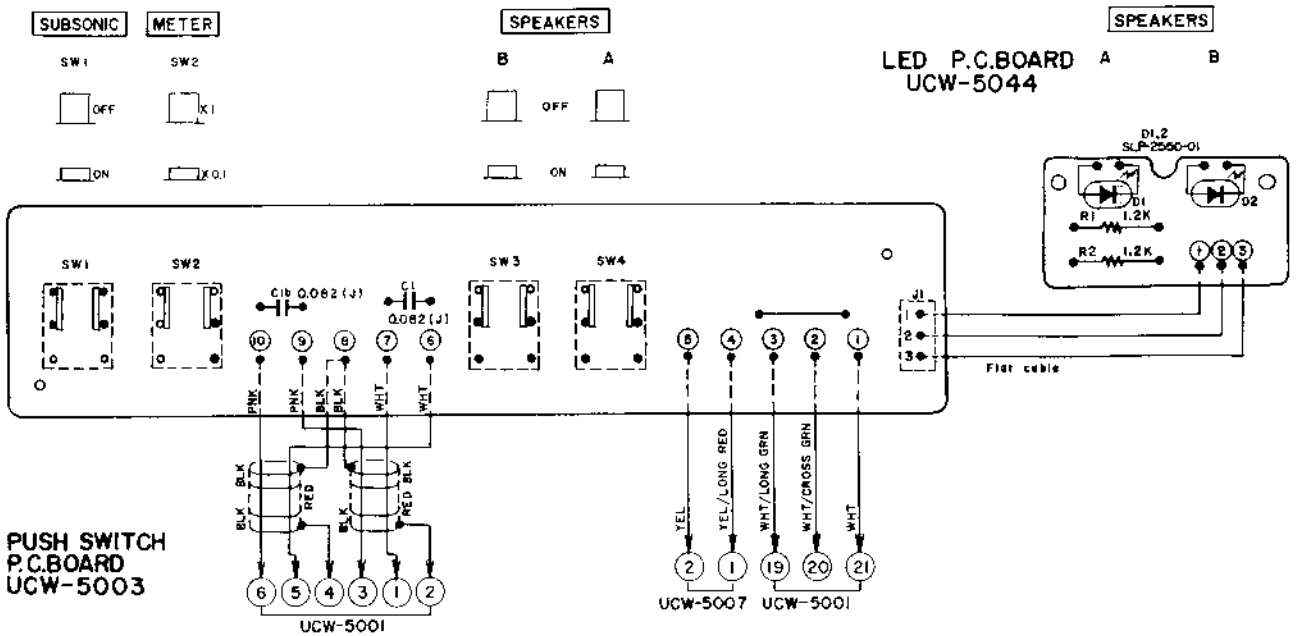

5) PULSE POWER SUPPLY P.C BOARD UCW-5004A

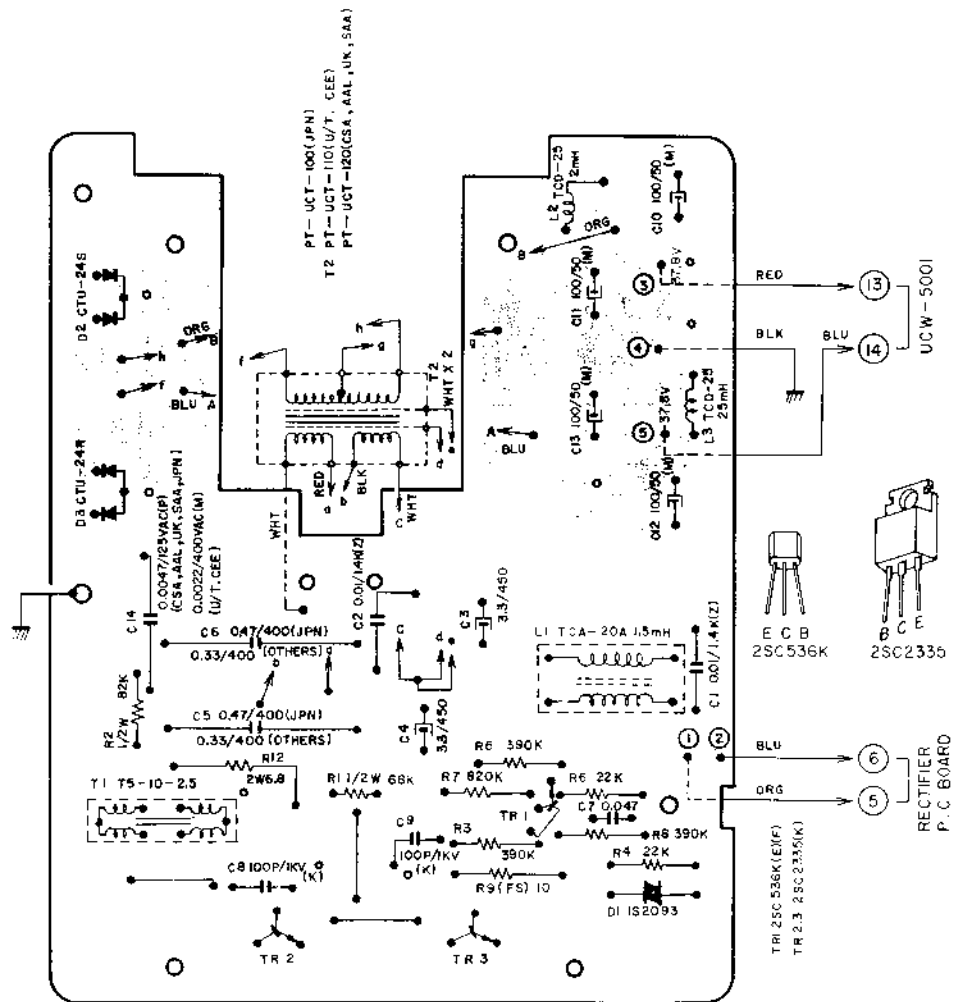

6) BAR METER P.C BOARD UCW-5006

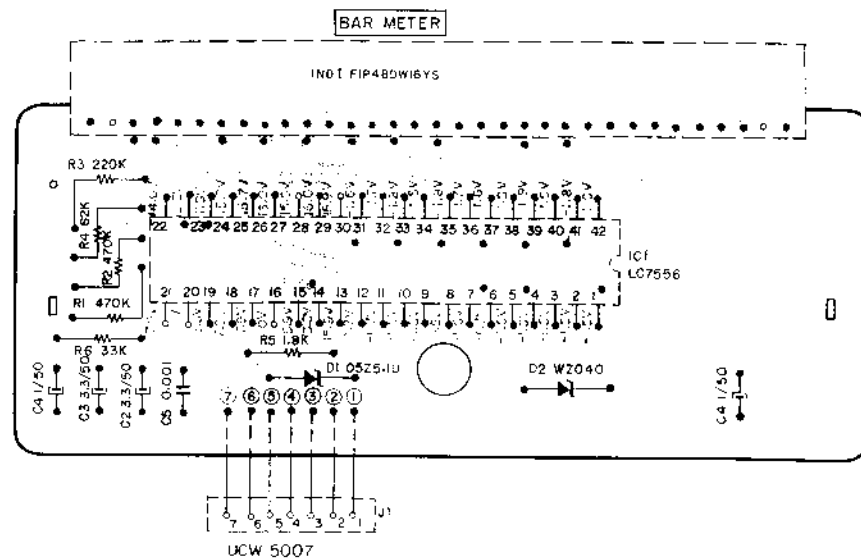

7) BAR METER DRIVE P.C BOARD UCW-5007

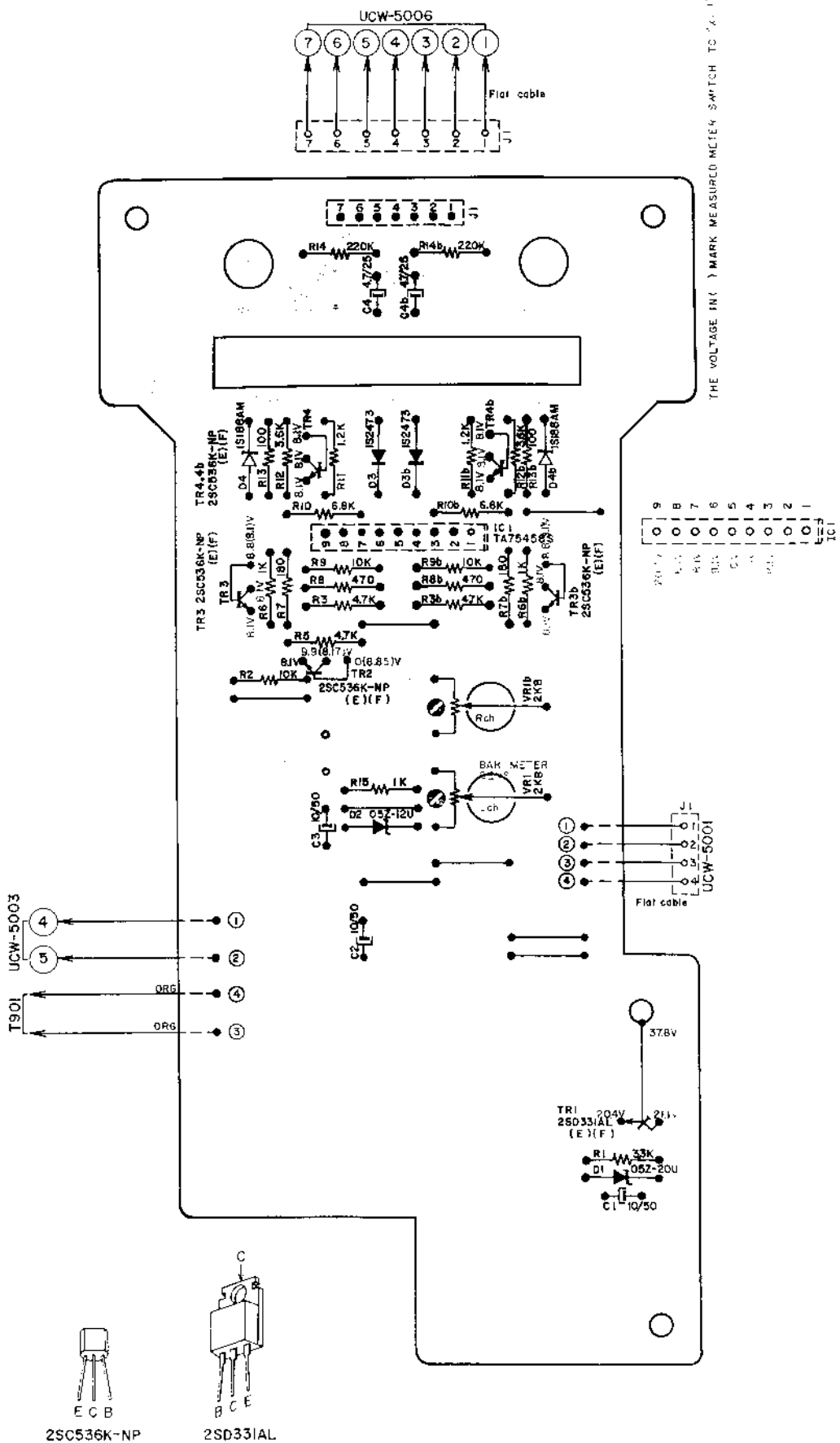

8) RECTIFIER P.C BOARD (U/T) UCW-5045

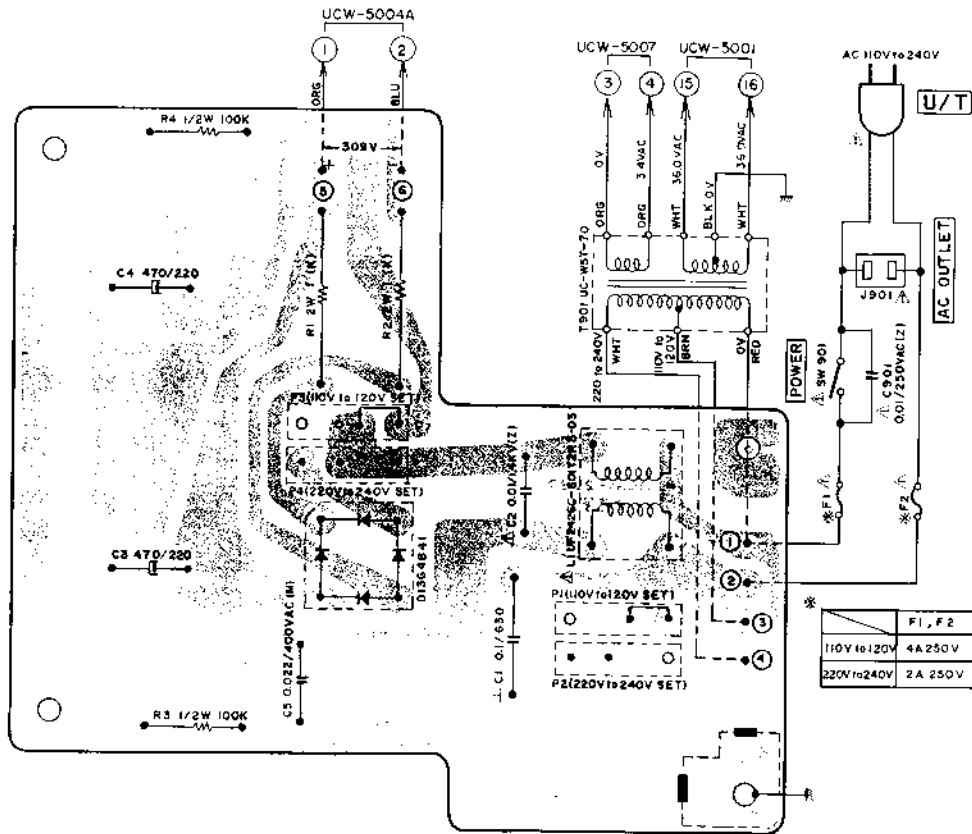

9) RECTIFIER P.C BOARD (CEE, UK, SAA) UCW-5005 (2ED)

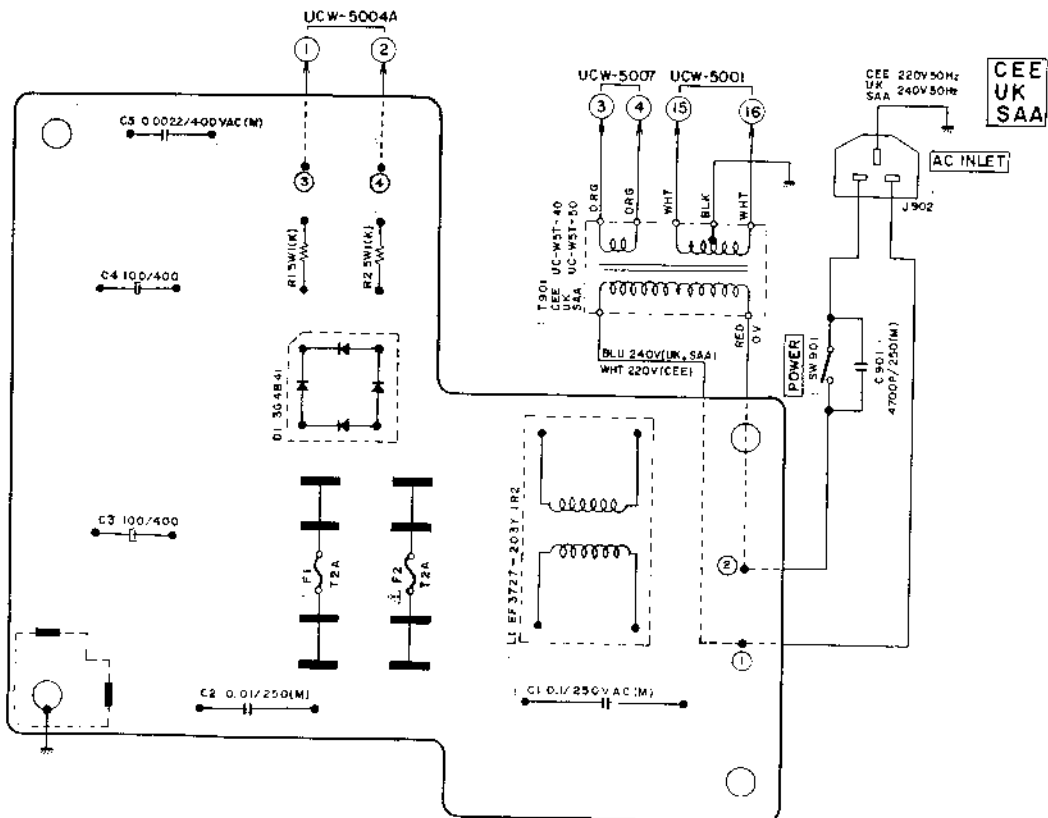

10) RECTIFIER P.C BOARD (CSA, AAL, JPN) UCW-5064

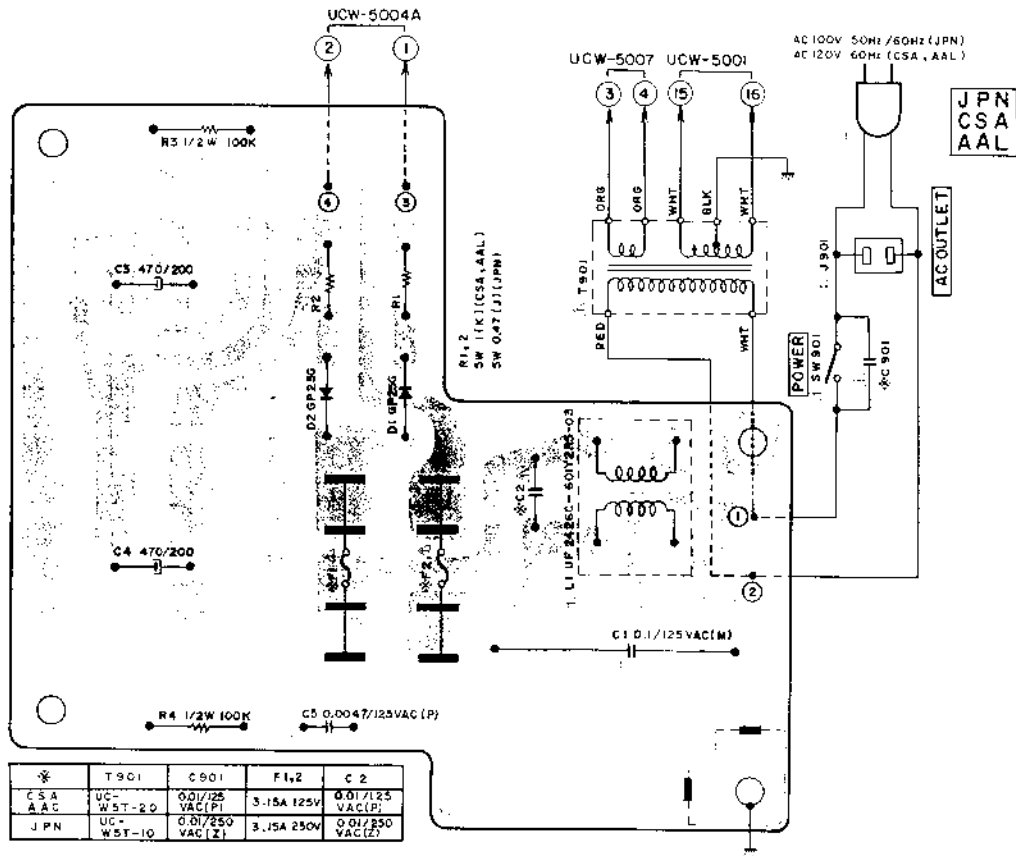

ADP-1000
 REVISION 10/78
 UCW-5007 UCW-5001 WITH MAIN FACTORY
 PARTS LIST
 UCW-5004A
 UCW-5007 UCW-5001
 UCW-5004A UCW-5007 UCW-5001
 UCW-5004A UCW-5007 UCW-5001

SECTION 3

PARTS LIST

TABLE OF CONTENTS

I. MODEL UC-A5	
1. RECOMMENDED SPARE PARTS LIST	40
2. PRE AMP P.C BOARD (UCA-5001) BLOCK	42
3. FINAL ASSEMBLY BLOCK	44
II. MODEL UC-W5	
1. RECOMMENDED SPARE PARTS LIST	46
2. MAIN AMP P.C BOARD (UCW-5001) BLOCK	48
3. PULSE POWER SUPPLY P.C BOARD (UCW-5004A) BLOCK. .	48
4. BAR METER P.C BOARD (UCW-5006) BLOCK	49
5. BAR METER DRIVE P.C BOARD (UCW-5007) BLOCK	49
6. RECTIFIER P.C BOARD (UCW-5045/5005/5064) BLOCK ...	49
7. PUSH SWITCH P.C BOARD (UCW-5003) BLOCK	49
8. FINAL ASSEMBLY BLOCK	50
INDEX	
1. MODEL UC-A5	52
2. MODEL UC-W5	53

Resistor and Capacitor which is not listed in this parts list, please refer to COMMON LIST FOR SERVICE PARTS.

HOW TO USE THIS PARTS LIST

1. This parts list is compiled by various individual blocks based on assembly process.
2. When ordering parts, please describe parts number, serial number, and model number in detail.
3. How to read List

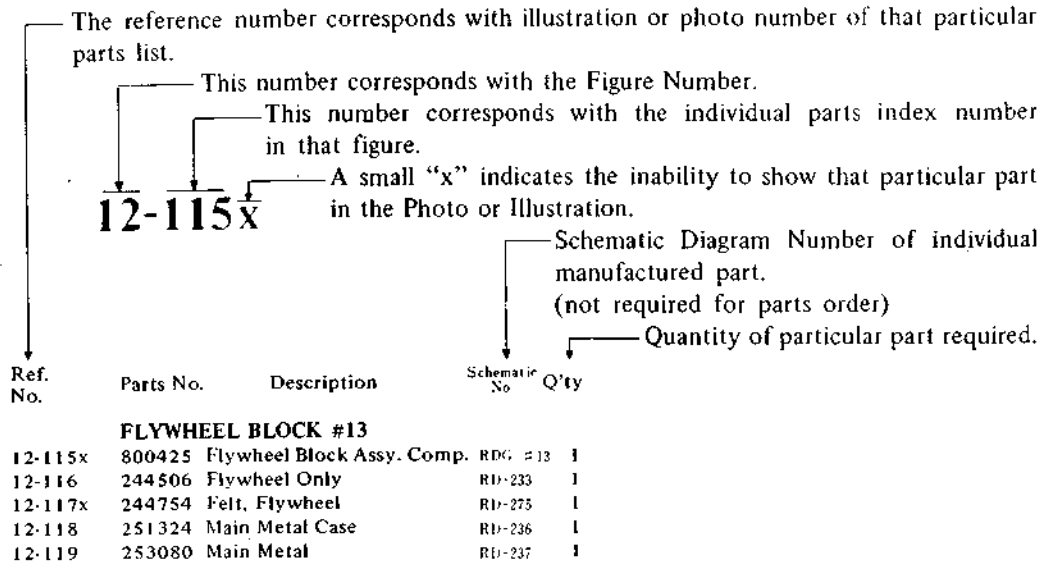

4. The symbol numbers shown on the P.C. Board list can be matched with the Composite Views of Components of the Schematic Diagram or Service Manual.
5. Please utilize separate "Common List for Service Parts" for Resistor Parts orders.
6. The shape of the parts and parts name, etc. can be confirmed by comparing them with the parts shown on the Electrical Parts Table of P.C. Board.
7. Both the kind of part and installation position can be determined by the Parts Number. To determine where a parts number is listed, utilize Parts Index at end of Parts List.
It is necessary first of all to find the Parts Number. This can be accomplished by using the Reference Number listed at right of parts number in the Parts Index. (meaning of ref. no. outlined in Item 3 above).
8. Utilize separate "Price List for Parts" to determine unit price. The most simple method of finding parts Price is to utilize the reference number.

- CAUTION:**
1. When placing an order for parts, be sure to list the parts no., model no., and description. There are instances in which if any of this information is omitted, parts cannot be shipped or the wrong parts will be delivered.
 2. Please be careful not to make a mistake in the parts no. if the parts no. is in error, a part different from the one ordered may be delivered.
 3. Because parts number and parts unit supply in the Preliminary Service Manual (Basic Parts List) may be partially changed, please use this parts list for all future reference.

WARNING: Δ INDICATES SAFETY CRITICAL COMPONENTS. FOR CONTINUED SAFETY, REPLACE SAFETY CRITICAL COMPONENTS ONLY WITH MANUFACTURER'S RECOMMENDED PARTS.

AVERTISSEMENT: Δ INDIQUE LES COMPOSANTS CRITIQUES DE SURETE. POUR MAINTENIR LE DEGRE DE SECURITE DE L'APPAREIL, NE REMPLACEZ LES COMPOSANTS DONT LE FONCTIONNEMENT EST CRITIQUE POUR LA SECURITE QUE PAR DES PIECES RECOMMANDEES PAR LE FABRICANT.

AC INLET SYSTEM

This model is equipped with an AC INLET SYSTEM. Please refer to the AC INLET SYSTEM CHART below for the specific type. By the AC INLET SYSTEM, AC (mains) cord can be connected to and disconnected from the model because the model is provided with socket exclusively for AC (mains) cord on its main body. Please note, however, that certain models are not equipped with this system and has a built-in AC (mains) cord as before.

AC INLET SYSTEM CHART

CLASS I

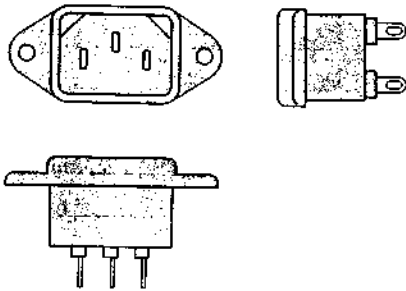

Picture 1
AC INLET
to be
installed
on machines

CLASS II

⊠ This mark indicating double insulation will be attached to machine's rear panel

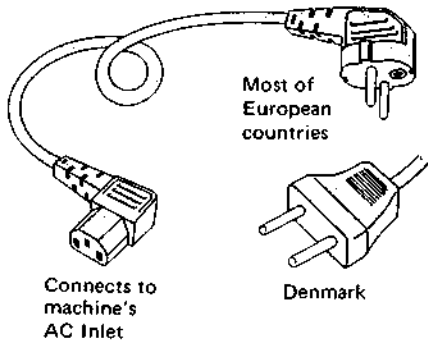
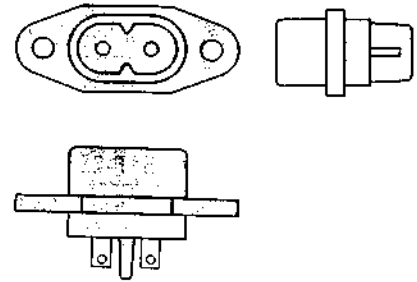

Picture 2
AC (mains)
cord

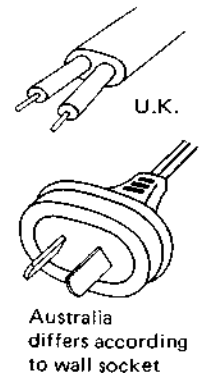
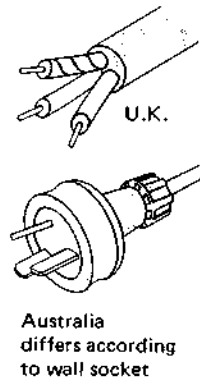
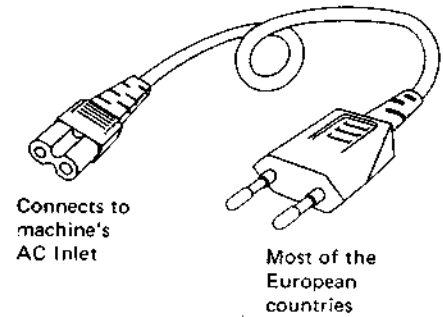

Parts List for AC (mains) Cord Set

	Standard	Description	Type of AC Inlet	Parts No.
Class I	CEE	Cord Set CEE (3 cores)	3P	EW302993
	BEAB	Cord Set BEAB (3 cores)	3P	EW302994
	SAA	Cord Set SAA (3 cores)	3P	EW302996
	U/T	Cord Set U/T (3 cores)	3P	EW302646
Class II	CEE	Cord Set CEE (2 cores)	2P	EW638144
	BEAB	Cord Set BEAB (2 cores)	2P	EW302995
	SAA	Cord Set SAA (2 cores)	2P	EW302991
	U/T	Cord Set U/T (2 cores)	2P	EW302899

I. MODEL UC-A5

1. RECOMMENDED SPARE PARTS LIST

Because, if the parts listed below are on hand, almost any repair can be accomplished, we suggest that you stock these Recommended Spare Parts Items.

Parts No.	Description	Notes
BA324214	Pre Amp P.C Board Comp. UC-A5 (CEE)	CEE, UK, SAA
BA324140	Pre Amp P.C Board Comp. UC-A5 (CSA)	CSA, AAL
BA326066	Pre Amp P.C Board Comp. UC-A5 (JPN)	
BA323398	Pre Amp P.C Board Comp. UC-A5 (U/T)	
BT319372	△ Power Trans. UCA5T-10	JPN
BT323363	△ Power Trans. UCA5T-20	CSA, AAL
BT323364	△ Power Trans. UCA5T-40	CEE
BT323365	△ Power Trans. UCA5T-50	UK, SAA
BT323362	△ Power Trans. UCA5T-70	U/T
ED322773	LED SLP-255D-01	
ED315365	Silicon Diode DS131B	
ED315366	Silicon Diode DS132B	
ED316143	Silicon Diode 1S2473-HS	
ED224526	Silicon Diode 10D1	
ED323057	Silicon Varister MV12	
ED323353	Zener Diode 05Z-12L	
ED325115	Zener Diode 05Z-15L	
ED323354	Zener Diode 05Z-6.2L	
ED325080	Zener Diode 05Z-9.1L	
EF310199	△ Fuse 0.5A 250V	U/T
EF321323	△ Fuse 250mA 250V	U/T
EF308848	△ Fuse 400mA 125V	CSA, AAL
EF309389	△ Fuse 400mA 250V	JPN
EF300586	△ Fuse (EAWK) 250MAT	CEE, UK, SAA
EI323346	IC M51231P	
EI323347	IC M54832P	
EI323054	IC TA7322P	
EI315243	IC TA78005P	
EJ301513	△ Inlet 2P	
EJ324119	DIN Socket 8P TCS1080-01-101	
EP323350	Relay L-23M DC 12V	
ES315159	△ Push SW. SDG1P	JPN
ES310839	△ Push SW. SDG1P-E 5A/80A 250V	U/T, CEE, UK, SAA
ES665875	△ Push SW. SDG1P-J TV-3 UL/CSA	CSA, AAL
ES324118	Push SW. J-K2105	
ES323368	Remote Push SW. SSR24351D	
ES323369	Remote Rotary Slide SW. SSR24602D	
ES323371	Rotary Slide SW. SRZW44S	
ES323367	Sensi Touch SW. KEC 10001	
ET311792	FET 2SK150 (GR) (Y)	

Parts No.	Description	Notes
ET552870	FET 2SK30A (Y) (GR)	
ET323529	Transistor 2SA608K-NP (E) (F)	
ET305463	Transistor 2SA970 (GR) (BL)	
ET323348	Transistor 2SB507 (D) (E) (F)	
ET219868	Transistor 2SB560 (E) (F)	
ET307195	Transistor 2SC2240 (GR) (BL)	
ET316171	Transistor 2SC536K-NP (E) (F)	
ET323366	Transistor 2SD313AL (D) (E) (F)	
ET219857	Transistor 2SD438 (E) (F)	
ET310148	Transistor 2SD612K (E) (F)	
EV320326	Double-Axial 6-Throw/Vol. 250KZ×2, 250KBM×2, 50KC×2	
EV323373	2-Throw/Vol. GM70ED54A-100KC×2	
EV324105	2-Throw/Vol. GM70ED55A-100KC×2	
EW306427	△ AC Cord (JPN)	
EW306428	△ AC Cord (U/T)	
EW305691	△ AC Cord CUL	
EW302995	△ AC Cord Set BEAB 2 Cores	UK
EW315767	△ AC Cord Set CEE 2 Cores	CEE
EW322401	△ AC Cord Set SAA 2 Cores	
EZ631945	△ Strain Relief SR-4N-4	U/T, JPN, CSA, AAL
EZ225145	△ 2-Throw AC Outlet	U/T, JPN, CSA, AAL

2. PRE AMP P.C BOARD (UCA-5001) BLOCK

Symbol No.	Parts No.	Description	Schematic No.	Symbol No.	Parts No.	Description	Schematic No.
2-1	BA323398	Pre Amp P.C Board Comp. UC-A5 (U/T)	UCA-5031	2-R18	ER318400	Carbon/R. F 1/4WS 68 ohms (J)	35-11-30
2-2	BA326066	Pre Amp P.C Board Comp. UC-A5 (JPN)	UCA-5031	2-R27	ER323067	Metal Film/R. 1/4W 100 ohms (F)	35-17-20
2-3	BA324140	Pre Amp P.C Board Comp. UC-A5 (CSA) (CSA, AAL)	UCA-5031	2-R31	ER323351	Metal Film/R. 1/4W 3.74K (F)	35-17-20
2-4	BA324214	Pre Amp P.C. Board UC-A5 (CEE) (CEE, UK, SAA)	UCA-5031	2-R32	ER323352	Metal Film/R. 1/4W 45.3K (F)	35-17-20
2-IC1	EI323054	IC TA7322P	45-8-419	2-R116	ER307196	Carbon/R. F 1/4W 100 ohms (J)	35-11-25
2-IC2	EI323346	IC M51231P	45-8-420	2-R121	ER324106	Metal Oxide Film/R. 2W 2.2K (J)	35-15-8
2-IC3	EI323054	IC TA7322P	45-8-419	2-R133,134	ER322591	Carbon/R. F 1/4WS 100 ohms (J)	35-11-30
2-IC4	EI323347	IC M54832P	45-8-421	2-R135	ER306805	Carbon/R. F 1/2W 100 ohms (J)	35-11-27
2-IC5	EI315243	IC TA78005P	45-8-384	2-C12	EC324101	NP/C. 4.7μF(M) 35WV	24-17-35
2-TR1	ET305463	Transistor 2SA970(GR)(BL)	45-1-303	2-C13	EC324104	NP/C. 2.2μF(M) 35WV	24-17-35
2-TR2,3	ET307195	Transistor 2SC2240(GR)(BL)	45-1-302	2-C21	EC324101	NP/C. 4.7μF(M) 35WV	24-17-35
2-TR4	ET305463	Transistor 2SA970(GR)(BL)	45-1-303	2-C27	EC324109	Styrol/C. 180PF(J) 50WV	24-11-17
2-TR5	ET311792	FET 2SK150(GR)(Y)(BL)	45-12-22	2-C29	EC314995	Styrol/C. 330PF(J) 50WV	24-11-17
2-TR6to8	ET552870	FET 2SK30A(Y)(GR)	45-12-4	2-C49,50	EC324101	NP/C. 4.7μF(M) 35WV	24-17-35
2-TR9to11	ET316171	Transistor 2SC536K-NP(E)(F)	45-1-362	2-C59	EC324115	Solid Aluminum/C. 2.2μF(M) 25WV	24-19-3
2-TR12to14	ET323529	Transistor 2SA608K-NP(E)(F)	45-1-375	2-C69	EC326583	Metallized Mylar/C. (Vert.) 0.047μF(K) 400WV	24-16-29
2-TR16	ET219857	Transistor 2SD438(E)(F)	45-1-233	2-5	EW319901	Remote Wire SWR1114	25-14-302
2-TR19	ET316171	Transistor 2SC536K-NP(E)(F)	45-1-362	2-6	ES319902	Push Selector SUR510	25-14-102
2-TR20	ET310148	Transistor 2SD612K(E)(F)	45-1-308	2-7	EW319903	Remote Wire SWR6120	25-14-303
2-TR21	ET316171	Transistor 2SC536K-NP(E)(F)	45-1-362	2-8	ES319904	Rotary Selector SRZWM6	25-14-103
2-TR22	ET323366	Transistor 2SD313AL(D)(E)(F)	45-1-105	2-9	ZS325495	Tapping Screw, #2 BR 3x6	
2-TR23	ET316171	Transistor 2SC536K-NP(E)(F)	45-1-362	2-10	ZS417216	Screw, Pan 3x4	
2-TR24	ET219868	Transistor 2SB560(E)(F)	45-1-232				
2-TR25,26	ET323529	Transistor 2SA608K-NP(E)(F)	45-1-375				
2-TR27	ET323348	Transistor 2SB507(D)(E)(F)	45-1-376				
2-TR28to32	ET323529	Transistor 2SA608K-NP(E)(F)	45-1-375				
2-D1	ED323057	Silicon Varister MV12	45-10-16				
2-D2,3	ED316143	Silicon Diode 1S2473-HS	45-3-53				
2-D4	ED323354	Zener Diode 05Z-6.2L	45-6-76				
2-D5	ED325115	Zener Diode 05Z-15L	45-6-76				
2-D6	ED323353	Zener Diode 05Z-12L	45-6-76				
2-D7	ED224526	Silicon Diode 10D1	45-2-11				
2-D8	ED315366	Silicon Diode DS132B	45-3-56				
2-D9	ED315365	Silicon Diode DS131B	45-3-55				
2-D10,11	ED325080	Zener Diode 05Z-9.1L	45-6-76				
2-D12	ED316143	Silicon Diode 1S2473-HS	45-3-53				
2-SW1	ES323368	Remote Push SW. SSR24351D	25-14-502				
2-SW2	ES323369	Remote Rotary Slide SW. SSR24602D	25-14-503				
2-SW3	ES323371	Rotary Slide SW. SRZW44S	25-6-190				
2-SW4	ES324118	Push SW. J-K2105	25-5-367				
2-VR1	EV649642	Semi-Fixed/Vol. (Solid Type) SR19R B220 ohm	36-19-10				
2-VR2	EV320326	Double-Axial 6-Throw/Vol. 250KZx2, 250KBMx2, 50KCx2	36-37-13				
2-VR3	EV324105	2-Throw/Vol. GM70ED55A-100KCx2	36-22-57				
2-VR4	EV323373	2-Throw/Vol. GM70ED54A-100KCx2	36-22-56				
2-RL1to7	EP323350	Relay L-23M DC12V	47-2-34				
2-J1	EJ323349	Pin Jack 16P	32-1-109				
2-R14	ER318400	Carbon/R. F 1/4WS 68 ohms (J)	35 11-30				

When ordering parts, please quote Parts Number, Description and Model Number.



3. FINAL ASSEMBLY BLOCK

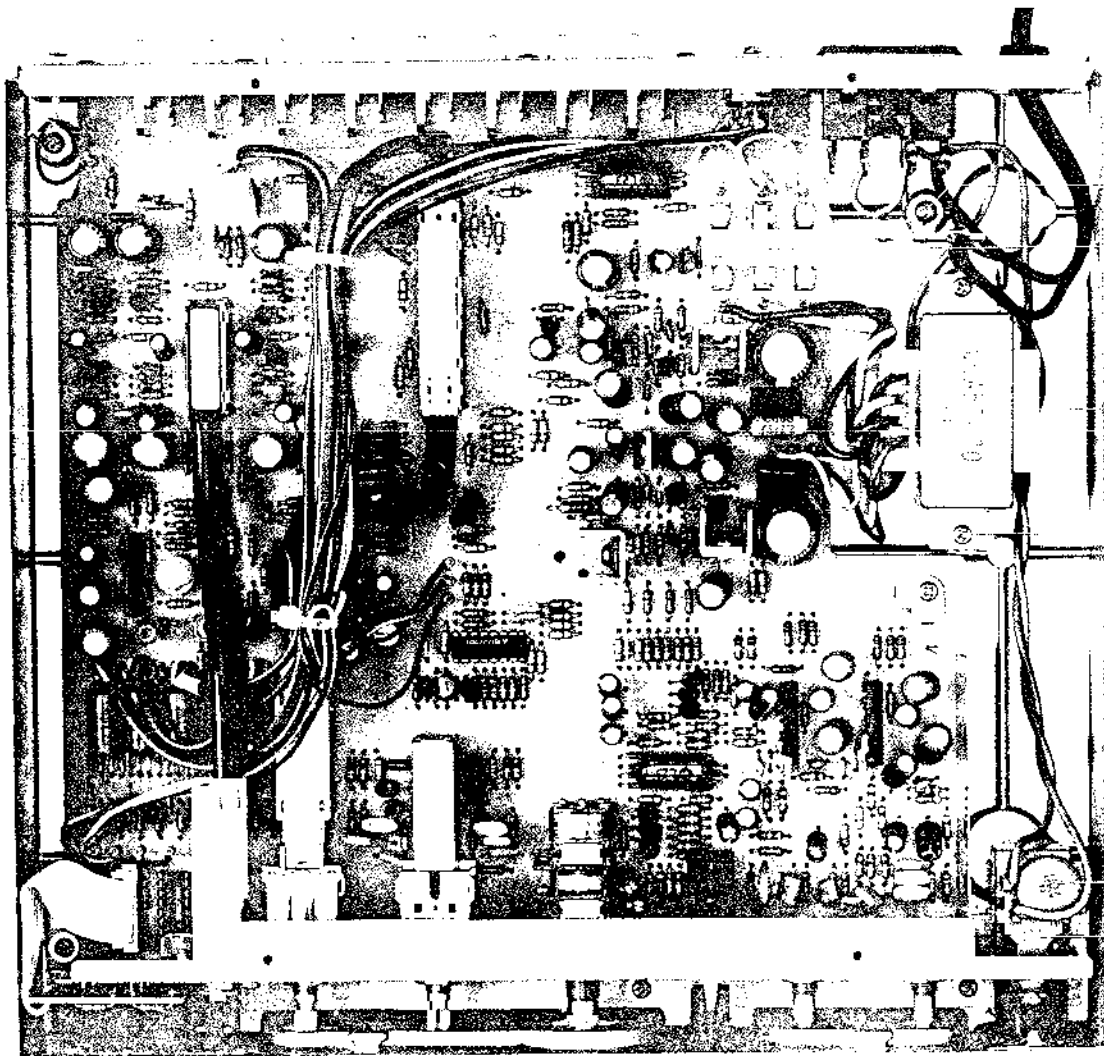
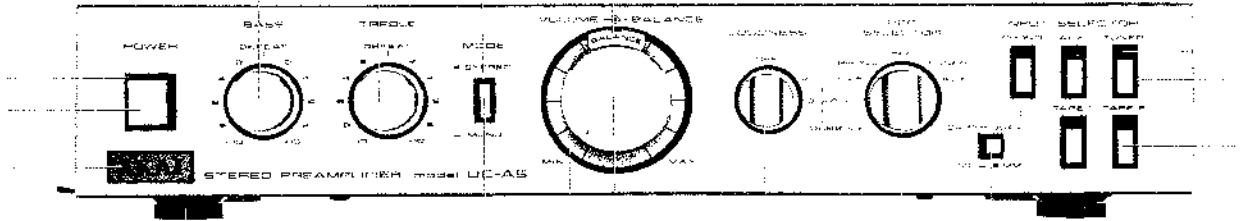

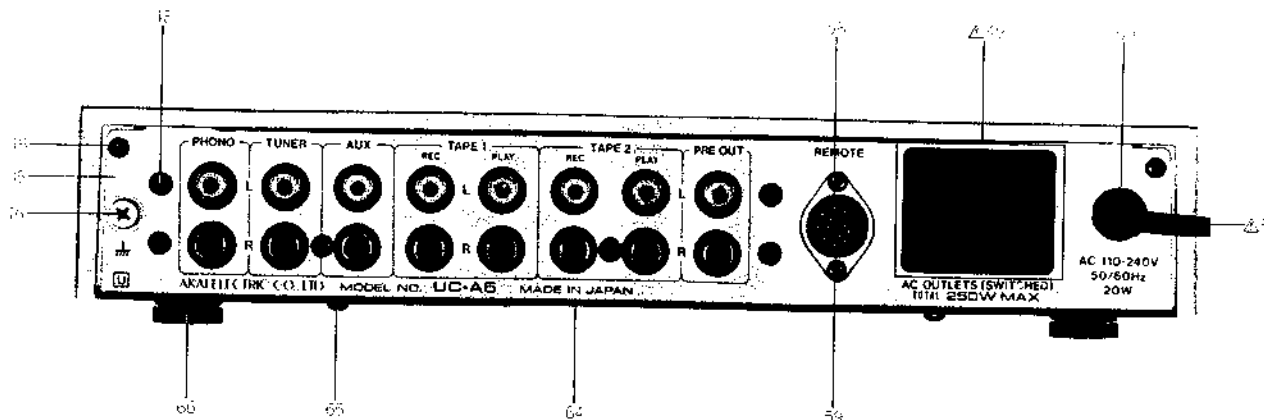

FINAL ASSEMBLY BLOCK

Ref. No.	Parts No.	Description	Schematic No.	Ref. No.	Parts No.	Description	Schematic No.
INPUT P.C BOARD BLOCK							
3-1x	ES323367	Sensi Touch SW. KEC 10001	25-9-9	3-43x	SP323328	Rear Panel (CEE-BL)	UCA-5018
3-2	ED322773	LED SLP-255D-01	45-15-37	3-44x	SP323330	Rear Panel (UK, SAA-BL)	UCA-5018
3-3	SE323318	Escutcheon (C)	UCA-5014	3-45	ZS609208	Tapping Screw, #2 Pan 3x8 (Black)	
3-4	SB323313	Button (C)	UCA-5011	3-46	EJ325358	Earth Terminal	32-1-115
3-5x	SB323314	Button (C-BL)	UCA-5011	3-47x	ZW651082	Washer (SPC) D3.2x10x1t	
3-6x	ZS325495	Tapping Screw, #2 BR 3x6		3-48	ZW698308	Nylon Rivet (NRB) 3x5.5 (Black)	2-7-54
FINAL ASSEMBLY BLOCK				3-49	EZ225145	△ 2-Throw AC Outlet (U/T, CSA, AAL)	31-1-166
3-7	SM323339	Name Plate	A0565	3-50	EZ631945	△ Strain Relief SR-4N-4 (U/T, JPN, CSA, AAL)	2-7-49
3-8	SB323305	Button (A)	UCA-5005	3-51	EW306428	△ AC Cord (U/T)	26-3-64
3-9x	SB323306	Button (A-BL)	UCA-5005	3-52x	EW306427	△ AC Cord (JPN)	26-3-63
3-10	SE323307	Escutcheon (A)	UCA-5006	3-53x	EW305691	△ AC Cord CUL (CSA, AAL)	26-3-65
3-11x	ZG323308	Spring (A)	UCA-5007	3-54x	EW315767	△ AC Cord Set CEE 2 Cores (CEE)	26-3-72
3-12	SB323309	Button (B)	UCA-5008	3-55x	EW302995	△ AC Cord Set BEAB 2 Cores (UK)	26-3-57
3-13x	SB323310	Button (B-BL)	UCA-5008	3-56x	EW322401	△ AC Cord Set SAA 2 Cores (SAA)	26-3-77
3-14	SE323311	Escutcheon (B)	UCA-5009	3-57x	EJ301513	△ Inlet 2P (CEE, UK, SAA)	31-1-200
3-15x	ZG323312	Spring (B)	UCA-5010	3-58	EJ324119	Din Socket 8P TCS1080-01-101	31-1-255
3-16	SZ324122	Decoration Ring	UCF-6512,6513	3-59	ZS447761	Tapping Screw, #2 BR 3x6 (Black)	
3-17x	SZ324124	Decoration Ring (BL)	UCF-6512,6513	3-60	EF310199	△ Fuse 0.5A 250V (U/T)	39-1-64
3-18	SB323315	Button (D)	UCA-5012	3-61x	EF309389	△ Fuse 400mA 250V (JPN)	39-1-64
3-19x	SB323316	Button (D-BL)	UCA-5012	3-62x	EF308848	△ Fuse 400mA 125V (CSA, AAL)	39-1-65
3-20x	ZG323317	Spring (C)	UCA-5013	3-63x	EF300586	△ Fuse (EAWK) 250MAT (CEE, UK, SAA)	39-1-60
3-21	ES310839	△ Push SW. SDG1P-E 5A/80A 250V (U/T, CEE, UK, SAA)	25-5-310	3-64	SP323331	Bottom Plate	UCA-5019
3-22x	ES665875	△ Push SW. SDG1P-J TV-3 UL/CSA (CSA, AAL)	25-5-199	3-65	ZS609197	Tapping Screw #2, Pan 3x6 (Black)	
3-23x	ES315159	△ Push SW. SDG1P (JPN)	25-5-330	3-66	SA324129	Foot	UCF-5521
3-24	EC321302	△ Ceramic/C. E 0.01μF(Z) 250VAC (U/T, JPN)	24-5-90	3-67x	ZW550642	Washer (SPC) D3.1x8x0.5t	
3-25x	EC314688	△ Ceramic/C. DE7150 FZ 0.01μF(P) 125W (CSA, AAL)	24-5-87	3-68x	ZS608477	Screw, Pan 3x4 (Black)	
3-26x	EC327382	△ MP/C. (Vert.) 0.0047μF(M) 250WV (CEE, UK, SAA)	24-9-134	3-69x	ZW305013	Pop Rivet D3.2 (AAL)	7-6-9
3-27x	ZS417216	Screw, Pan 3x4		3-70	SK323332	Knob (A)	UCA-5020
3-28	ZS462194	Tapping Screw, #2 Pan 3x8(W=8)		3-71x	SK323333	Knob (A-BL)	UCA-5020
3-29	ZS666336	Tapping Screw, #2 Pan 3x8		3-72	SK324206	Double Knob (Lower-B) Part UC-A5	UCF-6520
3-30	BT323362	△ Power Trans. UCA5T-70 (U/T)	38-4-784	3-73x	SK324207	Double Knob (Lower-B-BL) Part UC-A5-BL	UCF-6520
3-31x	BT319372	△ Power Trans. UCA5T-10 (JPN)	38-4-871	3-74	SK324210	Double Knob (Upper) Part UC-F5	UCF-6521
3-32x	BT323363	△ Power Trans. UCA5T-20 (CSA, AAL)	38-4-781	3-75x	SK324211	Double Knob (Upper-BL) Part UC-F5-BL	UCF-6521
3-33x	BT323364	△ Power Trans. UCA5T-40 (CEE)	38-4-782	3-76	SK323334	Knob (B)	UCA-5021
3-34x	BT323365	△ Power Trans. UCA5T-50 (UK, SAA)	38-4-783	3-77x	SK323336	Knob (B-BL)	UCA-5021
3-35	SP323323	Rear Panel (U/T)	UCA-5018	3-78	SK323337	Knob (C)	UCA-5022
3-36x	SP319370	Rear Panel (JPN)	UCA-5018	3-79x	SK323338	Knob (C-BL)	UCA-5022
3-37x	SP323325	Rear Panel (CSA, AAL)	UCA-5018	3-80x	EF321323	△ Fuse 250mA 250V (U/T)	39-1-64
3-38x	SP323327	Rear Panel (CEE)	UCA-5018				
3-39x	SP323329	Rear Panel (UK, SAA)	UCA-5018				
3-40x	SP323324	Rear Panel (U/T-BL)	UCA-5018				
3-41x	SP319371	Rear Panel (JPN-BL)	UCA-5018				
3-42x	SP323326	Rear Panel (CSA-BL)	UCA-5018				

When ordering parts, please quote Parts Number, Description and Model Number.

II. MODEL UC-W5

1. RECOMMENDED SPARE PARTS LIST

Because, if the parts listed below are on hand, almost any repair can be accomplished, we suggest that you stock these Recommended Spare Parts Items.

Parts No.	Description	Notes
BA323449	Main Amp P.C Board Comp. UC-W5	
BT320514	△ Power Trans. UC-W5T-10	JPN
BT323548	△ Power Trans. UCW5T-20	CSA, AAL
BT323549	△ Power Trans. UCW5T-40	CEE
BT323550	△ Power Trans. UCW5T-50	UK, SAA
BT323547	△ Power Trans. UCW5T-70	U/T
BT320515	△ Pulse Trans. PT-UCT-100	JPN
BT323568	△ Pulse Trans. PT-UCT-110	U/T, CEE
BT323569	△ Pulse Trans. PT-UCT-120	CSA, AAL, UK, SAA
ED562386	Germanium Diode 1S188AM	
ED322773	LED SLP-255D-01	
ED323513	Silicon Diode CTU-24R	
ED323512	Silicon Diode CTU-24S	
ED245430	Silicon Diode GP08G	
ED214457	Silicon Diode 1S2472	
ED316143	Silicon Diode 1S2473-HS	
ED323556	Silicon Stack 3G4B41	
ED323573	Trigger Diode 1S2093	
ED322810	Zener Diode WZ-040	
ED323530	Zener Diode 05Z-12U	
ED323534	Zener Diode 05Z-20U	
ED322774	Zener Diode 05Z5.1U	
EF306950	△ Fuse 2A 250V	U/T
EF323080	△ Fuse 3.15A 125V	CSA, AAL
EF326639	△ Fuse 3.15A 250V	JPN
EF306952	△ Fuse 4A 250V	U/T
EF601301	△ Fuse (Semko T) 2AT	CEE, UK, SAA
EI322791	IC LC7556	
EI323562	IC STK-0040(2)-A	
EI326550	IC STK-0050(2)-A	
EI323563	IC STK-3042	
EI323564	IC TA7317P	
EI322599	IC TA75458S	
EI323436	OSC. Trans P.C Board Assy	
EJ321168	△ AC Outlet IR13	U/T, JPN, CSA, AAL
EJ296853	△ 3P Inlet CM-3	CEE, UK, SAA
EJ301199	Headphone Jack 3P64M	
EJ323552	Push Terminal 4P	
EM322584	Bar Meter FIP48DW16YS	
EO323570	Choke Coil TCA-20A 1.5MH	

Parts No.	Description	Notes
EP323565	Relay G2Z-222P-US DC 24V	
ER323561	△ Line Filter UF2426C-601Y2R5-03	U/T, JPN, CSA, AAL
ER325268	△ Power Filter EF3727-203Y1R2	CEE, UK, SAA
ES315159	△ Push SW. SDG1P	JPN
ES310839	△ Push SW. SDG1P-E 5A/80A 250V	U/T, CEE, UK, SAA
ES665875	△ Push SW. SDG1P-J TV-3 UL/CSA	CSA, AAL
ES323555	2-Throw Push SW. J-K2109	
ET311792	FET 2SK150 (GR) (Y) (BL)	
ET323529	Transistor 2SA608K-NP (E) (F)	
ET324134	Transistor 2SA984K (E) (F)	
ET307195	Transistor 2SC2240 (GR) (BL)	
ET324133	Transistor 2SC2274 (E) (F)	
ET323572	Transistor 2SC2335 (K)	
ET316171	Transistor 2SC536K-NP (E) (F)	
ET323567	Transistor 2SD331AL (E) (F)	
EW306427	△ AC Cord (JPN)	
EW306428	△ AC Cord (U/T)	
EW305691	△ AC Cord CUL	CSA, AAL

2. MAIN AMP P.C BOARD (UCW-5001) BLOCK

Symbol No.	Parts No.	Description	Schematic No.
2-1	BA323449	Main Amp P.C Board Comp. UC-W5	UCW-5059
2-IC1	EI323563	IC STK-3042	45-8-423
2-IC2	EI323564	IC TA7317P	45-8-424
2-TR1	ET311792	FET 2SK150(GR)(Y)(BL)	45-12-22
2-TR2	ET316171	Transistor 2SC536K-NP(E)(F)	45-1-362
2-TR3	ET323529	Transistor 2SA608K-NP(E)(F)	45-1-375
2-TR4	ET316171	Transistor 2SC536K-NP(E)(F)	45-1-362
2-TR5	ET324134	Transistor 2SA984K(E)(F)	45-1-378
2-TR6	ET323529	Transistor 2SA608K-NP(E)(F)	45-1-375
2-TR7	ET324133	Transistor 2SC2274(E)(F)	45-1-377
2-TR8	ET323529	Transistor 2SA608K-NP(E)(F)	45-1-375
2-TR9	ET307195	Transistor 2SC2240(GR)(BL)	45-1-302
2-TR10	ET323529	Transistor 2SA608K-NP(E)(F)	45-1-375
2-D1	ED214457	Silicon Diode 1S2472	45-3-41
2-D2,3	ED323530	Zener Diode 05Z-12U	45-6-76
2-D4to8	ED245430	Silicon Diode GP08G	45-2-68
2-D9to13	ED214457	Silicon Diode 1S2472	45-3-41
2-RL1,2	EP323565	Relay G2Z-222P-US DC24V	47-2-35
2-VR1	EV380204	Semi-Fixed/Vol. (Solid Type) SR19R 1kΩ	36-19-10
2-L1	EO324220	Phase Compensation Coil 2.2μH(K)	23-1-417
2-J2	EJ323566	Pin Jack 2P	32-1-110
2-R17,18	ER324222	Metal Plate/R. 2W 0.22 ohm(K)	35-16-38
2-R34	ER409814	Metal Oxide Film/R. 2W 220 ohm(K)	35-15-8
2-C12	EC662128	Solid Aluminum/C. (Vert.) 2.2μF(M) 25WV	24-19-2
2-C13,14	EC323523	NP/C. (Vert.) 2.2μF(M) 25WV	24-17-26
2-C20	EC327715	NP/C. (Vert.) 47μF(M) 10WV	24-17-26
2-C21	EC621257	Solid Aluminum/C. (Vert.) 0.47μF(M) 25WV	24-19-2
2-C24	EC662128	Solid Aluminum/C. (Vert.) 2.2μF(M) 25WV	24-19-2

3. PULSE POWER SUPPLY P.C BOARD (UCW-5004A) BLOCK

Symbol No.	Parts No.	Description	Schematic No.
3-TR1	ET316171	Transistor 2SC536K-NP(E)(F)	45-1-362
3-TR2,3	ET323572	Transistor 2SC2335(K)	45-1-381
3-D1	ED323573	Trigger Diode 1S2093	45-3-65
3-D2	ED323512	Silicon Diode CTU-24S	45-2-101
3-D3	ED323513	Silicon Diode CTU-24R	45-2-102
3-T1	EI323436	OSC. Trans P.C Board Assy	UCW-5051
3-T2	BT323568	Pulse Trans. PT-UCT-110 (U/T, CEE)	23-1-394
3-T2	BT320515	Pulse Trans. PT-UCT-100 (JPN)	23-1-428
3-T2	BT323569	Pulse Trans. PT-UCT-120 (CSA, AAL, UK, SAA)	23-1-395
3-L1	EO323570	Choke Coil TCA-20A 1.5MH	23-1-392
3-L2	EO323571	Inductor TCD-25 20μH	23-1-393
3-R1	ER324231	Metal Oxide Film/R. 1W 68K(J) (U/T, CEE)	35-15-17
3-R9	ER310147	Carbon/R. F 1/4W 10 ohms(J)	35-11-25
3-R12	ER324232	Metal Oxide Film/R. 2W 6.8 ohms(J)	35-15-18
3-C1,2	EC551160	Ceramic/C. DB821 NA 0.01μF(Z) 1.4KWV	24-5-55
3-C3,4	EC323574	Elect./C. (Vert.) 3.3μF 450WV	24-12-66
3-C5	EC323525	Metallized Film/C. (Vert.) 0.33μF(K) 400WV (Except JPN)	24-16-7
3-C5	EC320516	Metallized Mylar/C. (Vert.) 0.47μF(K) 400WV (JPN)	24-16-7
3-C6	EC323525	Metallized Film/C. (Vert.) 0.33μF(K) 400WV (Except JPN)	24-16-7
3-C6	EC320516	Metallized Mylar/C. (Vert.) 0.47μF(K) 400WV (JPN)	24-16-7
3-C8,9	EC323517	Ceramic/C. (Vert.) DP3100 B 100PF(K) 1KWV	24-5-101
3-C14	EC325286	Ceramic/C. (Vert.) HS D 0.0022μF(M) 400WV (U/T, CEE, UK, SAA)	24-5-104
3-C14	EC325266	Ceramic/C. DE7100 0.0047μF(P) 125VAC (JPN, CSA, AAL)	24-5-87
3-1	ZS419670	Screw, Pan 3x12	
3-2	ZS422076	Screw, Pan 3x5	
3-3	ZG323474	Hold Spring	UCW-5023
3-4	ZS558101	Screw, Pan 3x6 w/Washer	

When ordering parts, please quote Parts Number, Description and Model Number.

4. BAR METER P.C BOARD (UCW-5006) BLOCK

Symbol No.	Parts No.	Description	Schematic No.
4-IND1	EM322584	Bar Meter FIP48DW16YS	59-1-2
4-IC1	EI322791	IC LC7556	45-8-425
4-D1	ED322774	Zener Diode 05Z5.1U	45-6-76
4-D2	ED322810	Zener Diode WZ-040	45-6-67

5. BAR METER DRIVE P.C BOARD (UCW-5007) BLOCK

Symbol No.	Parts No.	Description	Schematic No.
5-IC1	EI322599	IC TA75458S	45-8-415
5-TR1	ET323567	Transistor 2SD331AL(E)(F)	45-1-379
5-TR2to4	ET316171	Transistor 2SC536K-NP(E)(F)	45-1-362
5-D1	ED323534	Zener Diode 05Z-20U	45-6-76
5-D2	ED323530	Zener Diode 05Z-12U	45-6-76
5-D3	ED316143	Silicon Diode 1S2473-HS	45-3-53
5-D4	ED562386	Germanium Diode 1S188AM	45-3-24
5-VR1	EV323536	Semi-Fixed/Vol. D10 Axial 2k Ω	36-10-274
5-1	ZS413728	Screw, Bind 3x6 w/Washer	
5-2	ZW273756	Nut, #1 M3	

6. RECTIFIER P.C BOARD (UCW-5045/5005/5064) BLOCK

Symbol No.	Parts No.	Description	Schematic No.
6-D1	ED323556	Silicon Stack 3G4B41 (U/T, CEE, UK, SAA)	45-2-98
6-D1,2	ED313566	Silicon Diode GP-25G (JPN, CSA, AAL)	45-2-91
6-L1	ER325268	Δ Power Filter EF-3727-203Y1R2 (CEE, UK, SAA)	23-1-414
6-L1	ER323561	Δ Line Filter UF2426C-601Y2R5-03 (U/T, JPN, CSA, AAL)	23-1-390
6-R1,2	ER622978	Metal Plate/R. MPC71F1 5W 0.47 ohm(K) (U/T)	35-16-48
6-R1,2	ER323997	Cement/R. MPC71F1 5W 0.47 ohm(I) (JPN)	35-16-48
6-R1,2	ER326132	Cement/R. (Vert.) 5W 1 ohm(K) (Except U/T, JPN)	35-16-87
6-C1	EC258298	Δ MP/C. PEM271 0.1 μ (M) 250WV (CEE, UK, SAA)	24-9-118
6-C1	EC324135	Δ Metallized Film/C. (Vert.) 0.1 μ F(K) 630WV (U/T)	24-16-7
6-C1	EC320519	Δ Polypropylene/C. (Vert.) 0.1 μ F(M) 125VAC (JPN)	24-22-13
6-C1	EC326827	Δ Metallized Mylar/C. (Vert.) 0.1 μ F(M) 125VAC (CSA, AAL)	24-16-30
6-C2	EC325671	MP/C. (Vert.) 0.01 μ F(M) 250WV (CEE, UK, SAA)	24-9-134
6-C2	EC321302	Ceramic/C. E 0.01 μ F(Z) 250VAC (JPN)	24-5-90
6-C2	EC314688	Ceramic/C. DE7150 FZ 0.01 μ F(P) 125WV (CSA, AAL)	24-5-87
6-C3,4	EC323558	Elect./C. 100 μ F 400WV (CEE, UK, SAA)	24-12-68
6-C3,4	EC323560	Elect./C. 470 μ F 200WV (JPN, CSA, AAL)	24-12-69
6-C2to4	EC551160	Ceramic/C. DB821 NA 0.01 μ F(Z) 1.4KWV (U/T)	24-5-55
6-C5	EC325286	Ceramic/C. (Vert.) HS D 0.0022 μ F(M) 400WV (CEE, UK, SAA, U/T)	24-5-104
6-C5	EC325266	Ceramic/C. DE7100 0.0047 μ F(P) 125VAC (JPN, CSA, AAL)	24-5-87

7. PUSH SWITCH P.C BOARD (UCW-5003) BLOCK

Symbol No.	Parts No.	Description	Schematic No.
7-SW1,2	ES323555	2-Throw Push SW. J-K2109	25-5-360
7-SW3,4	ES323555	2-Throw Push SW. J-K2109	25-5-360

8. FINAL ASSEMBLY BLOCK

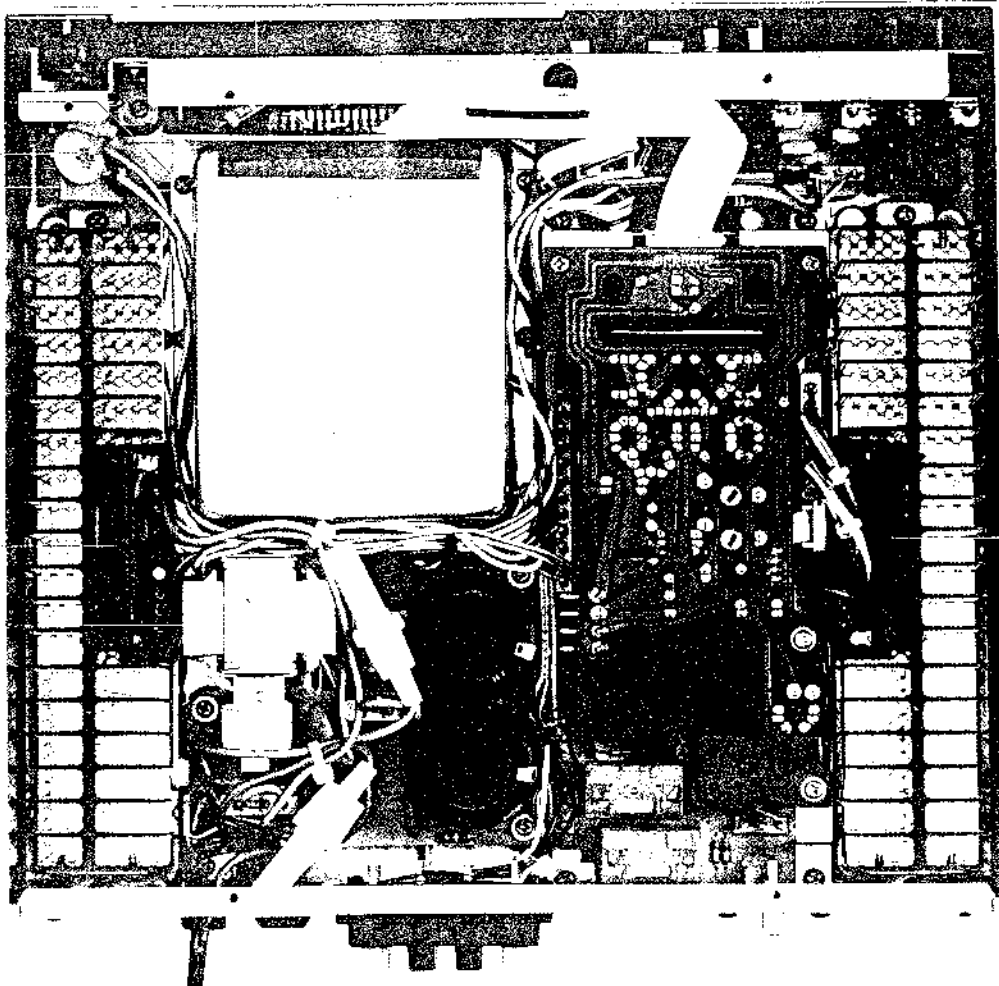
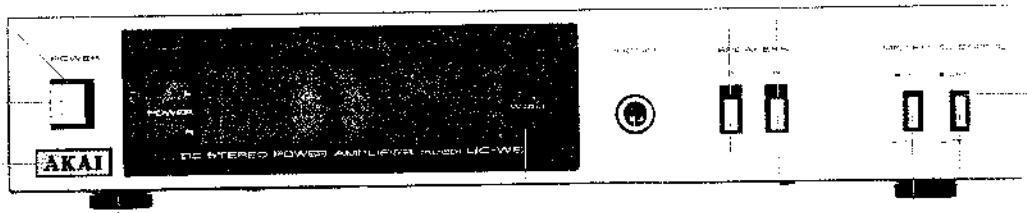

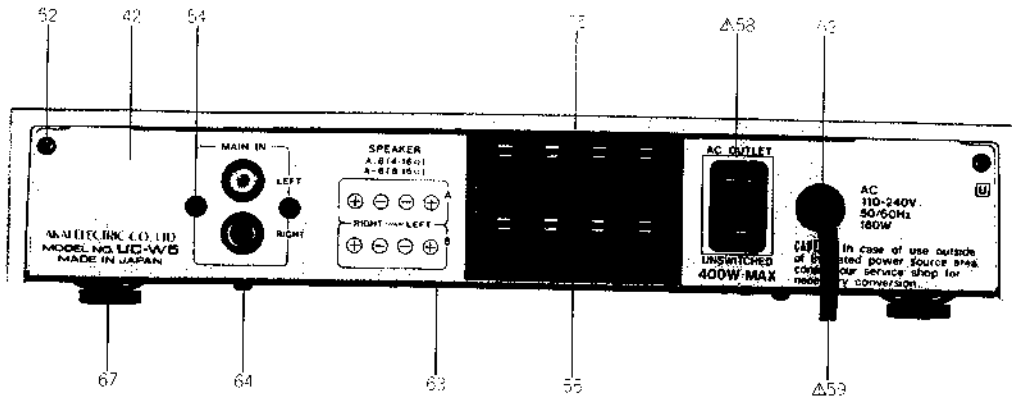

FINAL ASSEMBLY BLOCK

Ref. No.	Parts No.	Description	Schematic No.	Ref. No.	Parts No.	Description	Schematic No.
LED P.C BOARD BLOCK							
8-1	ED322773	LED SLP-255D-01	45-15-37	8-38x	BT323548	△ Power Trans. UCW5T-20 (CSA, AAL)	38-4-785
HEAT SINK (A) BLOCK							
8-2	EI326550	IC STK-0050(2)-A (U/T)	45-8-494	8-39x	BT323549	△ Power Trans. UCW5T-40 (CEE)	38-4-786
8-3x	EI323562	IC STK-0040(2)-A (Except U/T)	45-8-422	8-40x	BT323550	△ Power Trans. UCW5T-50 (UK, SAA)	38-4-787
8-4x	ZS447805	Tapping Screw, #2 BR 3x12		8-41x	ZS379350	Screw, Pan 3x6	
8-5x	ZS325495	Tapping Screw, #2 BR 3x6		8-42	SP323489	Rear Panel (U/T)	UCW-5035
PULSE POWER BLOCK							
8-6	ZS422076	Screw, Pan 3x5		8-43x	BD320524	Rear Panel (JPN)	UCW-5035
8-7x	TA323481	Packing (A)	UCW-5029	8-44x	SP323491	Rear Panel (CSA, AAL)	UCW-5035
8-8x	TA323486	Packing (B)	UCW-5033	8-45x	SP323494	Rear Panel (CEE)	UCW-5035
8-9x	ZS447840	Tapping Screw, #2 BR 3x8		8-46x	SP323496	Rear Panel (UK, SAA)	UCW-5035
ESCUTCHEON (B) BLOCK							
8-10	SE323465	Escutcheon (B)	UCW-5013	8-47x	SP323490	Rear Panel (U/T-BL)	UCW-5035
8-11x	SB323309	Button (B)	UCA-5008	8-48x	BD320525	Rear Panel (JPN-BL)	UCW-5035
8-12	SB323309	Button (B)	UCA-5008	8-49x	SP323492	Rear Panel (CSA-BL)	UCW-5035
8-13x	SB323310	Button (B-BL)	UCA-5008	8-50x	SP323495	Rear Panel (CEE-BL)	UCW-5035
8-14x	ZG323466	Spring	UCW-5014	8-51x	SP323497	Rear Panel (UK, SAA-BL)	UCW-5035
8-15	SB316355	Button (A)	CU-6005	8-52	ZS609208	Tapping Screw, #2 Pan 3x8 (Black) (U/T, JPN, CSA, AAL)	
8-16x	SB316356	Button (A-BL)	CU-6005	8-53x	ZS308846	Tapping Screw, #2 BR 3x8 (Oval Neck) (CEE, UK, SAA)	7-1-69
8-17x	ZS666336	Tapping Screw #2, Pan 3x8		8-54	ZW698308	Nylon Rivet (NRB) 3x5.5 (Black)	2-7-54
FINAL ASSEMBLY BLOCK							
8-18	SM323339	Name Plate	A0565	8-55	EJ323552	Push Terminal 4P	32-1-112
8-19	SB323305	Button (A)	UCA-5005	8-56x	EJ296853	△ 3P Inlet CM-3 (CEE, UK, SAA)	31-1-199
8-20x	SB323306	Button (A-BL)	UCA-5005	8-57x	ZS463353	Tapping Screw, #2 BR 3x8 (Black)	
8-21	SE323307	Escutcheon (A)	UCA-5006	8-58	EJ321168	△ AC Outlet IR13 (U/T, JPN, CSA, AAL)	31-1-257
8-22x	ZG323308	Spring (A)	UCA-5007	8-59	EW306428	△ AC Cord (U/T)	26-3-64
8-23	SE323462	Escutcheon (A)	UCW-5010	8-60x	EW306427	△ AC Cord (JPN)	26-3-63
8-24	SZ323463	Front Plate	UCW-5011	8-61x	EW305691	△ AC Cord CUL (CSA, AAL)	26-3-65
8-25x	SZ323464	Filter	UCW 5012,5047	8-62	EZ631945	Strain Relief SR-4N-4 (U/T, JPN, CSA, AAL)	2-7-49
8-26	ES310839	△ Push SW. SDG1P-E 5A/80A 250V (U/T, CEE, UK, SAA)	25-5-310	8-63	SP323500	Bottom Plate	UCW-5037
8-27x	ES315159	△ Push SW. SDG1P (JPN)	25-5-330	8-64	ZS609197	Tapping Screw #2, Pan 3x6 (Black)	
8-28x	ES665875	△ Push SW. SDG1P TV-3 UL/CSA (CSA, AAL)	25-5-199	8-65x	ZS319460	Tapping Screw, #2 BR 3x6 (Oval Neck)	7-1-69
8-29	EC321302	△ Ceramic/C. E 0.01μF(Z) 250VAC (U/T, JPN)	24-5-90	8-66x	ZS355522	Screw, Pan Head 3x6 (Black)	
8-30x	EC314688	△ Ceramic/C. DE7150 FZ 0.01μF(P) 125W (CSA, AAL)	24-5-87	8-67	SA324129	Foot	UCF-5521
8-31x	EC327382	△ MP/C. (Vert.) 0.0047μF(M) 250VW (CEE, UK, SAA)	24-9-134	8-68x	ZW550642	Washer (SPC) D3.1x8x0.5t	
8-32x	ZS417216	Screw, Pan 3x4		8-69x	ZS608477	Screw, Pan 3x4 (Black)	
8-33x	ZS455207	Tapping Screw, #2 BR 3x5		8-70x	ZW305013	Pop Rivet D3.2 (AAL)	7-6-9
8-34	EJ301199	Headphone Jack 3P64M	31-2-83	8-71x	EF306952	△ Fuse 4A 250V (U/T)	39-1-64
8-35x	ZS462194	Tapping Screw, #2 Pan 3x8(W=8)		8-72x	EF306950	△ Fuse 2A 250V (U/T)	39-1-64
8-36	BT323547	△ Power Trans. UCW5T-70(U/T)	38-4-786	8-73x	EF326639	△ Fuse 3.15A 250V (JPN)	39-1-64
8-37x	BT320514	△ Power Trans. UCW5T-10 (JPN)	38-4-372	8-74x	EF323080	△ Fuse 3.15A 125V (CSA, AAL)	39-1-65
				8-75x	EF601301	△ Fuse (Semko T) 2AT (CEE, UK, SAA)	39-1-53

When ordering parts, please quote Parts Number, Description and Model Number.

INDEX

1. MODEL UC-A5

Parts No.	Ref. No. & Symbol No.	Parts No.	Ref. No. & Symbol No.	Parts No.	Ref. No. & Symbol No.	Parts No.	Ref. No. & Symbol No.
BA323398	2-1	ET323529	2-TR28to32				
BA324140	2-3	ET552870	2-TR6to8				
BA324214	2-4	EV320326	2-VR2				
BA326066	2-2	EV323373	2-VR4				
BT319372	3-31x	EV324105	2-VR3				
BT323362	3-30	EV649642	2-VR1				
BT323363	3-32x	EW302995	3-55x				
BT323364	3-33x	EW305691	3-53x				
BT323365	3-34x	EW306427	3-52x				
EC314688	3-25x	EW306428	3-51				
EC314995	2-C29	EW315767	3-54x				
EC321302	3-24	EW319901	2-5				
EC324101	2-C12	EW319903	2-7				
EC324101	2-C21	EW322401	3-56x				
EC324101	2-C49,50	EZ225145	3-49				
EC324104	2-C13	EZ631945	3-50				
EC324109	2-C27	SA324129	3-66				
EC324115	2-C59	SB323305	3-8				
EC326583	2-C69	SB323306	3-9x				
EC327382	3-26x	SB323309	3-12				
ED224526	2-D7	SB323310	3-13x				
ED315365	2-D9	SB323313	3-4				
ED315366	2-D8	SB323314	3-5x				
ED316143	2-D2,3	SB323315	3-18				
ED316143	2-D12	SB323316	3-19x				
ED322773	3-2	SE323307	3-10				
ED323057	2-D1	SE323311	3-14				
ED323353	2-D6	SE323318	3-3				
ED323354	2-D4	SK323332	3-70				
ED325080	2-D10,11	SK323333	3-71x				
ED325115	2-D5	SK323334	3-76				
EF300586	3-63x	SK323336	3-77x				
EF308848	3-62x	SK323337	3-78				
EF309389	3-61x	SK323338	3-79x				
EF310199	3-60	SK324206	3-72				
EF321323	3-80x	SK324207	3-73x				
EI315243	2-IC5	SK324210	3-74				
EI323054	2-IC1	SK324211	3-75x				
EI323054	2-IC3	SM323339	3-7				
EI323346	2-IC2	SP319370	3-36x				
EI323347	2-IC4	SP319371	3-41x				
EJ301513	3-57x	SP323323	3-35				
EJ323349	2-J1	SP323324	3-40x				
EJ324119	3-58	SP323325	3-37x				
EJ325358	3-46	SP323326	3-42x				
EP323350	2-RL1to7	SP323327	3-38x				
ER306805	2-R135	SP323328	3-43x				
ER307196	2-R116	SP323329	3-39x				
ER318400	2-R14	SP323330	3-44x				
ER318400	2-R18	SP323331	3-64				
ER322591	2-R133,134	SZ324122	3-16				
ER323067	2-R27	SZ324124	3-17x				
ER323351	2-R31	ZG323308	3-11x				
ER323352	2-R32	ZG323312	3-15x				
ER324106	2-R121	ZG323317	3-20x				
ES310839	3-21	ZS325495	2-9				
ES315159	3-23x	ZS325495	3-6x				
ES319902	2-6	ZS417216	2-10				
ES319904	2-8	ZS417216	3-27x				
ES323367	3-1x	ZS447761	3-59				
ES323368	2-SW1	ZS462194	3-28				
ES323369	2-SW2	ZS608477	3-68x				
ES323371	2-SW3	ZS609197	3-65				
ES324118	2-SW4	ZS609208	3-45				
ES665875	3-22x	ZS666336	3-29				
ET219857	2-TR16	ZW305013	3-69x				
ET219868	2-TR24	ZW550642	3-67x				
ET305463	2-TR1	ZW651082	3-47x				
ET305463	2-TR4	ZW698308	3-48				
ET307195	2-TR2,3						
ET310148	2-TR20						
ET311792	2-TR5						
ET316171	2-TR9to11						
ET316171	2-TR19						
ET316171	2-TR21						
ET316171	2-TR23						
ET323348	2-TR27						
ET323366	2-TR22						
ET323529	2-TR12to14						
ET323529	2-TR25,26						

INDEX

2. MODEL UC-W5

Parts No.	Ref. No. & Symbol No.	Parts No.	Ref. No. & Symbol No.	Parts No.	Ref. No. & Symbol No.	Parts No.	Ref. No. & Symbol No.
BA323449	2-1	ER323997	6-R1,2	ZS666336	8-17x		
BD320524	8-43x	ER324222	2-R17,18	ZW273756	5-2		
BD320525	8-48x	ER324231	3-R1	ZW305013	8-70x		
BT320514	8-37x	ER324232	3-R12	ZW550642	8-68x		
BT320515	3-T2	ER325268	6-L1	ZW698308	8-54		
BT323547	8-36	ER326132	6-R1,2				
BT323548	8-38x	ER409814	2-R34				
BT323549	8-39x	ER622978	6-R1,2				
BT323550	8-40x	ES310839	8-26				
BT323568	3-T2	ES315159	8-27x				
BT323569	3-T2	ES323555	7-SW1,2				
EC258298	6-C1	ES323555	7-SW3,4				
EC314688	6-C2	ES665875	8-28x				
EC314688	8-30x	ET307195	2-TR9				
EC320516	3-C5	ET311792	2-TR1				
EC320516	3-C6	ET316171	2-TR2				
EC320519	6-C1	ET316171	2-TR4				
EC321302	6-C2	ET316171	3-TR1				
EC321302	8-29	ET316171	5-TR2to4				
EC323517	3-C8,9	ET323529	2-TR3				
EC323523	2-C13,14	ET323529	2-TR6				
EC323525	3-C5	ET323529	2-TR8				
EC323525	3-C6	ET323529	2-TR10				
EC323558	6-C3,4	ET323567	5-TR1				
EC323560	6-C3,4	ET323572	3-TR2,3				
EC323574	3-C3,4	ET324133	2-TR7				
EC324135	6-C1	ET324134	2-TR5				
EC325266	3-C14	EV323536	5-VR1				
EC325266	6-C5	EV380204	2-VR1				
EC325286	3-C14	EW305691	8-61x				
EC325286	6-C5	EW306427	8-60x				
EC325671	6-C2	EW306428	8-59				
EC326827	6-C1	EZ631945	8-62				
EC327382	8-31x	SA324129	8-67				
EC327715	2-C20	SB316355	8-15				
EC551160	3-C1,2	SB316356	8-16x				
EC551160	6-C2to4	SB323305	8-19				
EC621257	2-C21	SB323306	8-20x				
EC662128	2-C12	SB323309	8-11x				
EC662128	2-C24	SB323309	8-12				
ED214457	2-D1	SB323310	8-13x				
ED214457	2-D9to13	SE323307	8-21				
ED245430	2-D4to8	SE323462	8-23				
ED313566	6-D1,2	SE323465	8-10				
ED316143	5-D3	SM323339	8-18				
ED322773	8-1	SP323489	8-42				
ED322774	4-D1	SP323490	8-47x				
ED322810	4-D2	SP323491	8-44x				
ED323512	3-D2	SP323492	8-49x				
ED323513	3-D3	SP323494	8-45x				
ED323530	2-D2,3	SP323495	8-50x				
ED323530	5-D2	SP323496	8-46x				
ED323534	5-D1	SP323497	8-51x				
ED323556	6-D1	SP323500	8-63				
ED323573	3-D1	SZ323463	8-24				
ED562386	5-D4	SZ323464	8-25x				
EF306950	8-72x	TA323481	8-7x				
EF306952	8-71x	TA323486	8-8x				
EF323080	8-74x	ZG323308	8-22x				
EF326639	8-73x	ZG323466	8-14x				
EF601301	8-75x	ZG323474	3-3				
EI322599	5-IC1	ZS308846	8-53x				
EI322791	4-IC1	ZS319460	8-65x				
EI323436	3-T1	ZS325495	8-5x				
EI323562	8-3x	ZS355522	8-66x				
EI323563	2-IC1	ZS379350	8-41x				
EI323564	2-IC2	ZS413728	5-1				
EI326550	8-2	ZS417216	8-32x				
EJ296853	8-56x	ZS419670	3-1				
EJ301199	8-34	ZS422076	3-2				
EJ321168	8-58	ZS422076	8-6				
EJ323552	8-55	ZS447805	8-4x				
EJ323566	2-J2	ZS447840	8-9x				
EM322584	4-INDI	ZS455207	8-33x				
EO323570	3-L1	ZS462194	8-35x				
EO323571	3-L2	ZS463353	8-57x				
EO324220	2-L1	ZS558101	3-4				
EP323565	2-RL1,2	ZS608477	8-69x				
ER310147	3-R9	ZS609197	8-64				
ER323561	6-L1	ZS609208	8-52				

SECTION 4

SCHEMATIC DIAGRAM

1. SCHEMATIC DIAGRAM OF ICs
2. UC-A5 NO. 1600640A SCHEMATIC DIAGRAM
3. UC-W5 NO. 1600641A SCHEMATIC DIAGRAM

M54832P

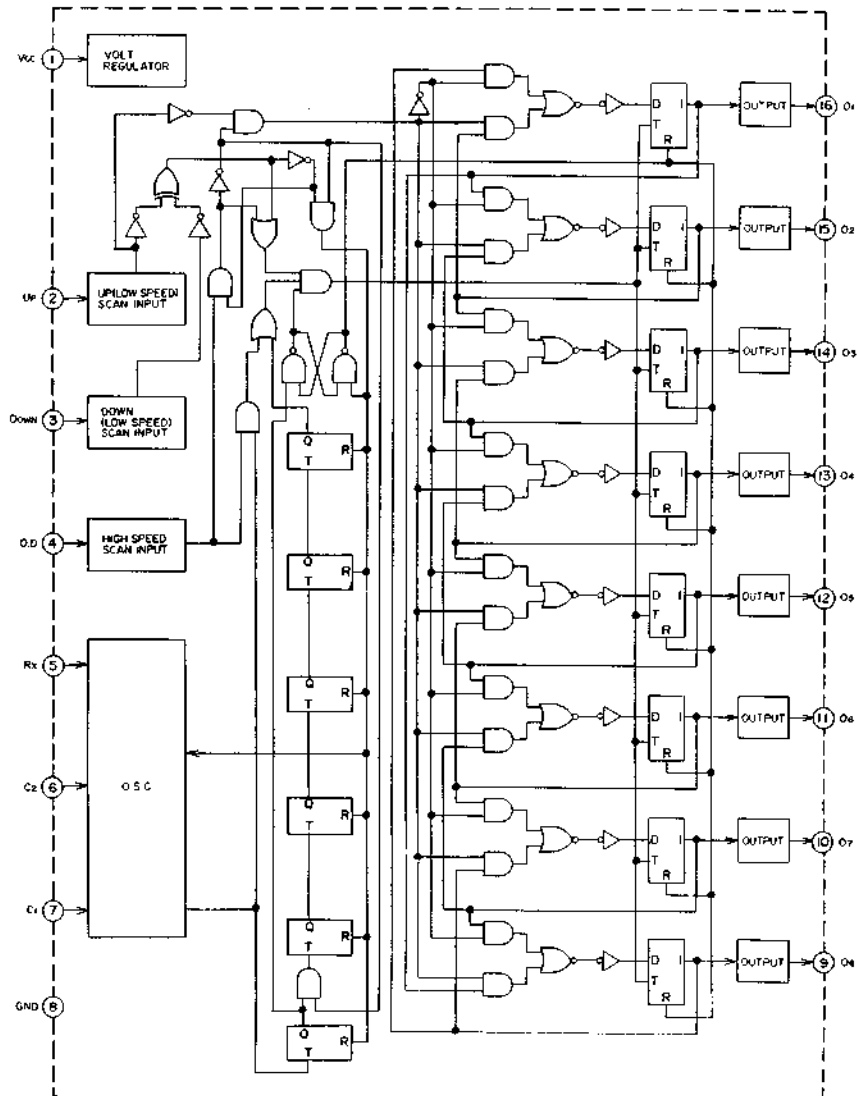

M51231P

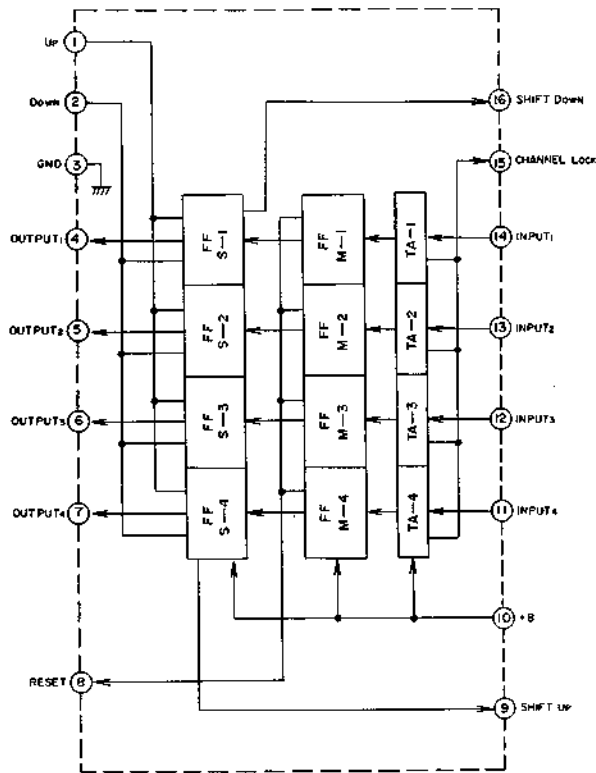

TA7322P

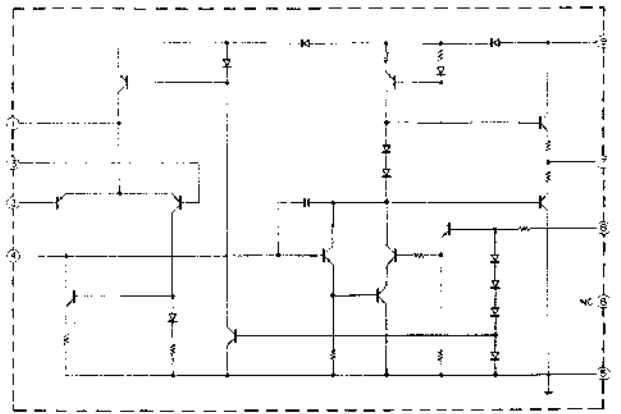

TA78005P

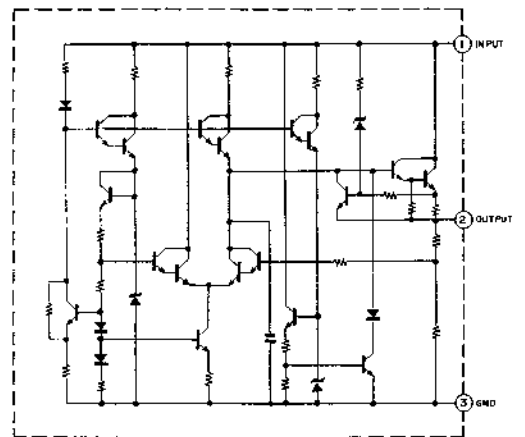

LC7556

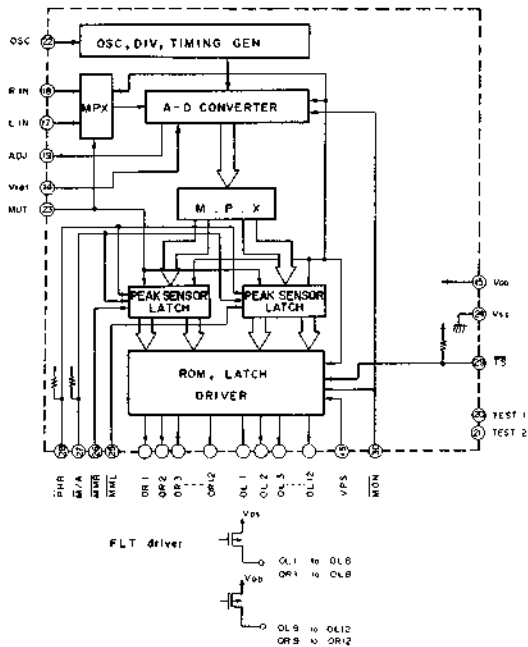

STK-3042

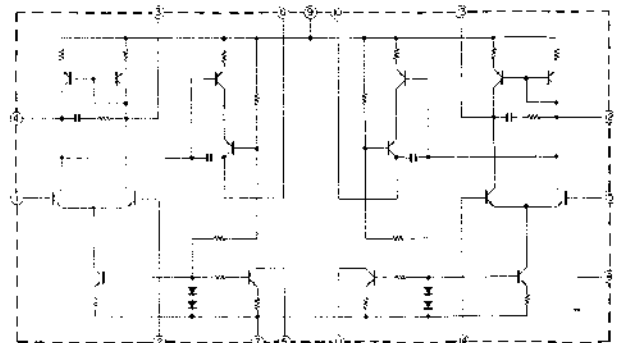

STK-0040II-A

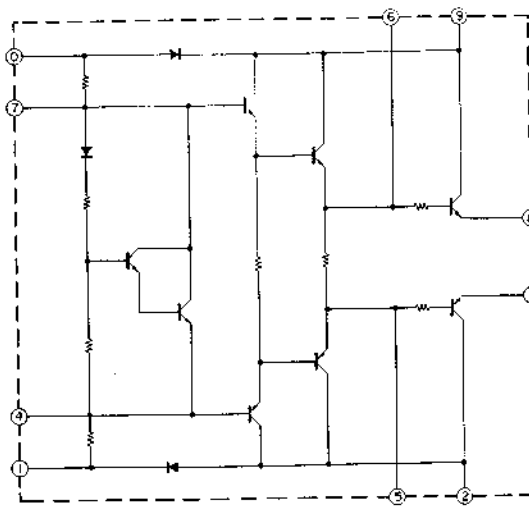

STK-0050II-A

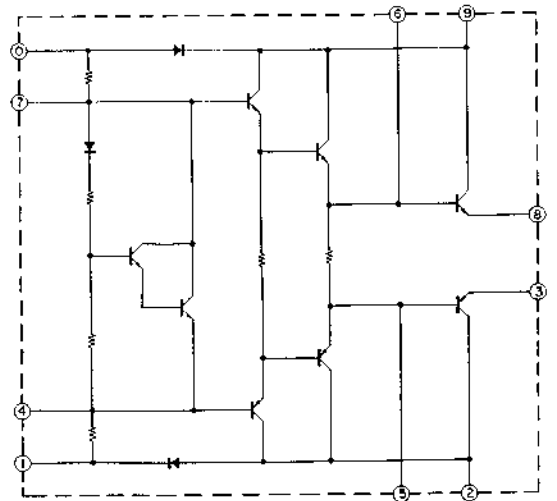

TA7317P

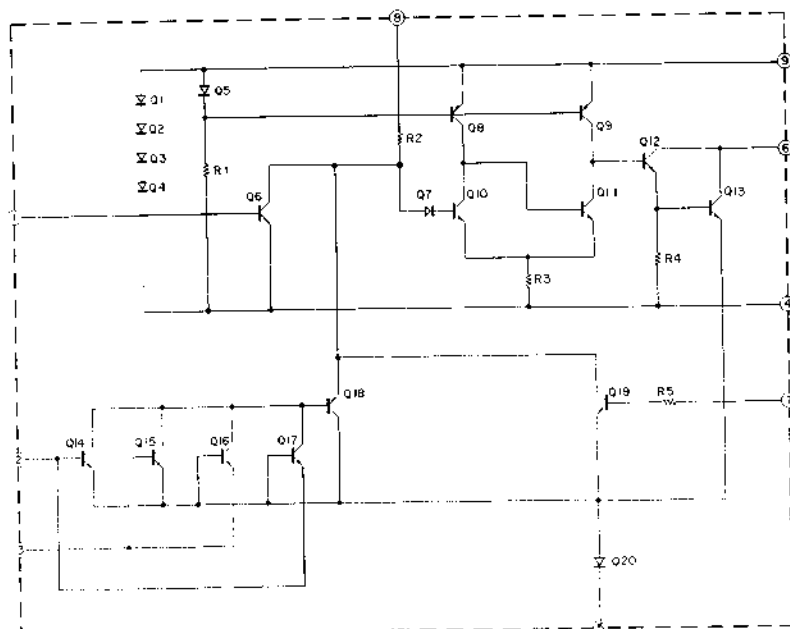
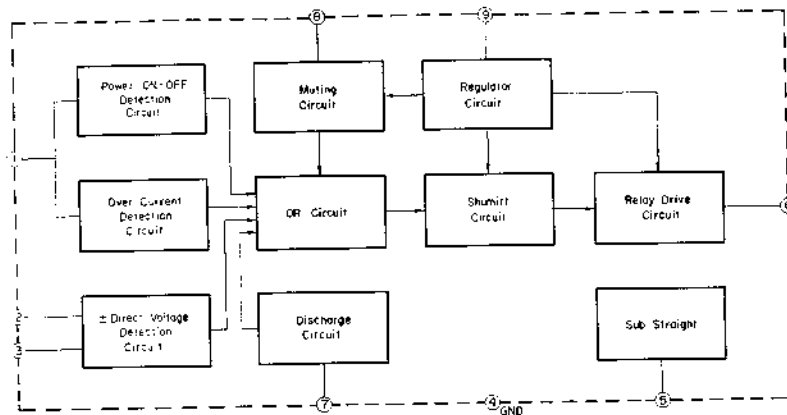

UC-A5

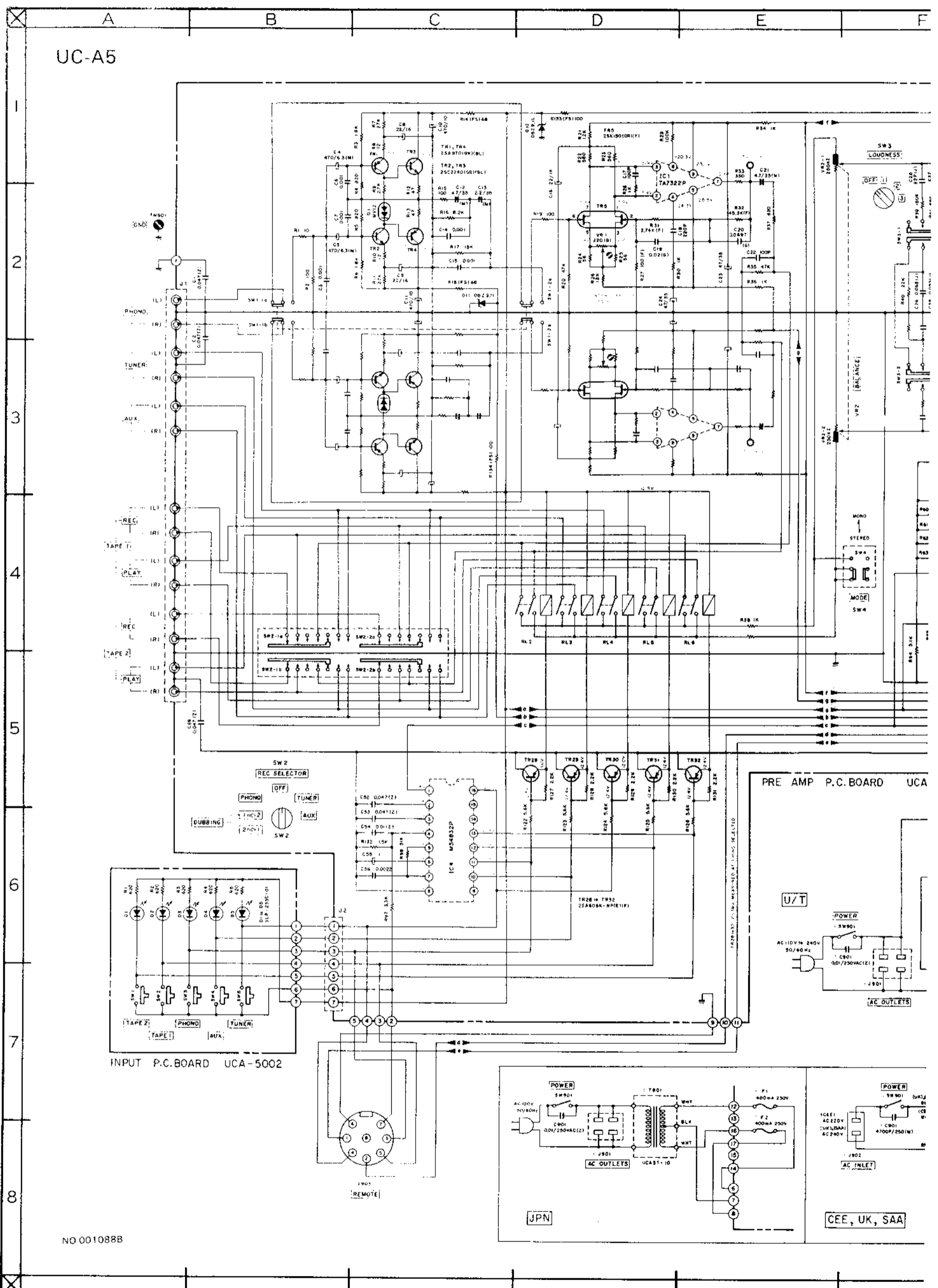

NO 001088B

G H I J K

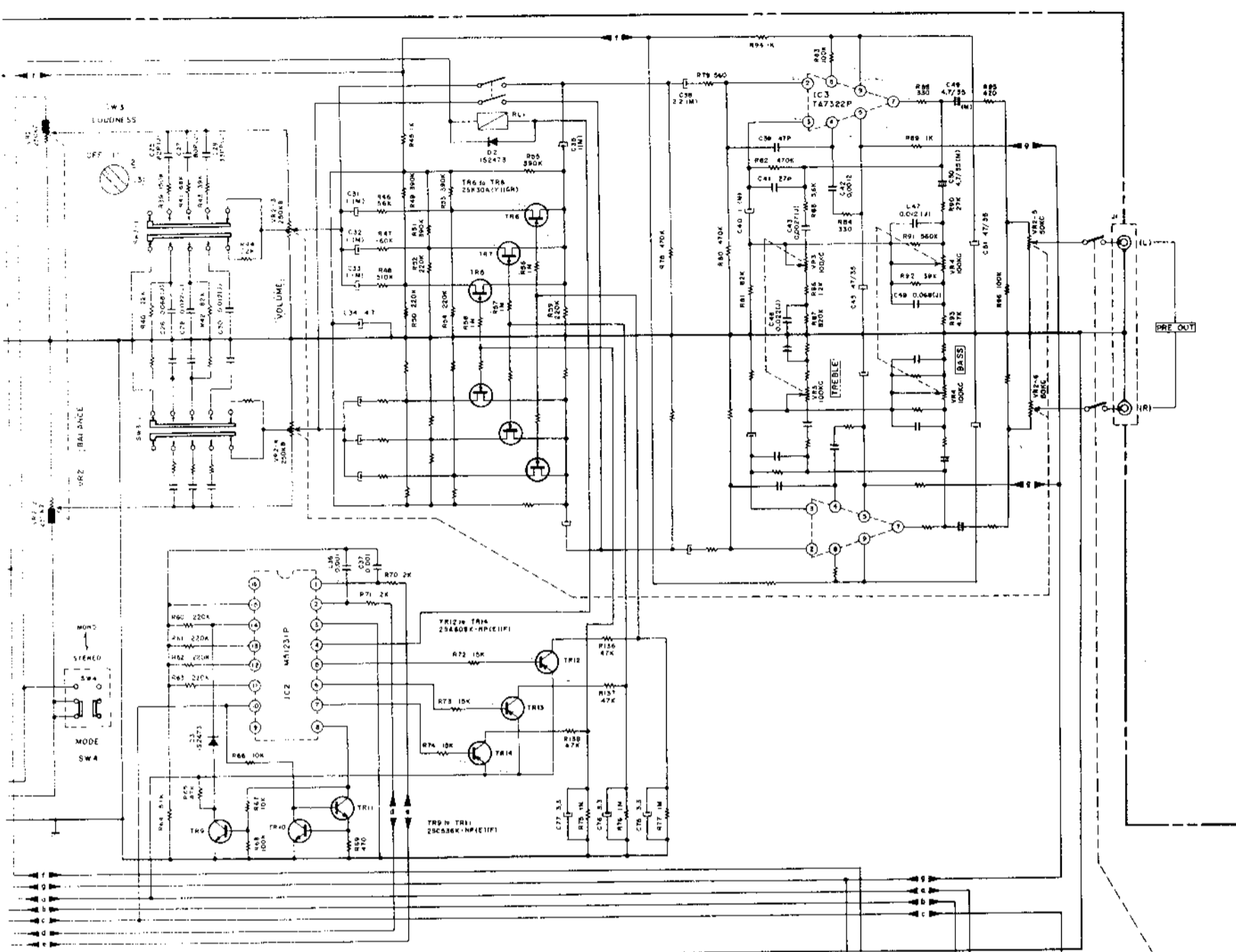

- 25A608K-NP
25A970
25C536K-NP
25C2240
- 25K30A
- 55B560
25B438
- 7478005P
- 25062K
- 250612K

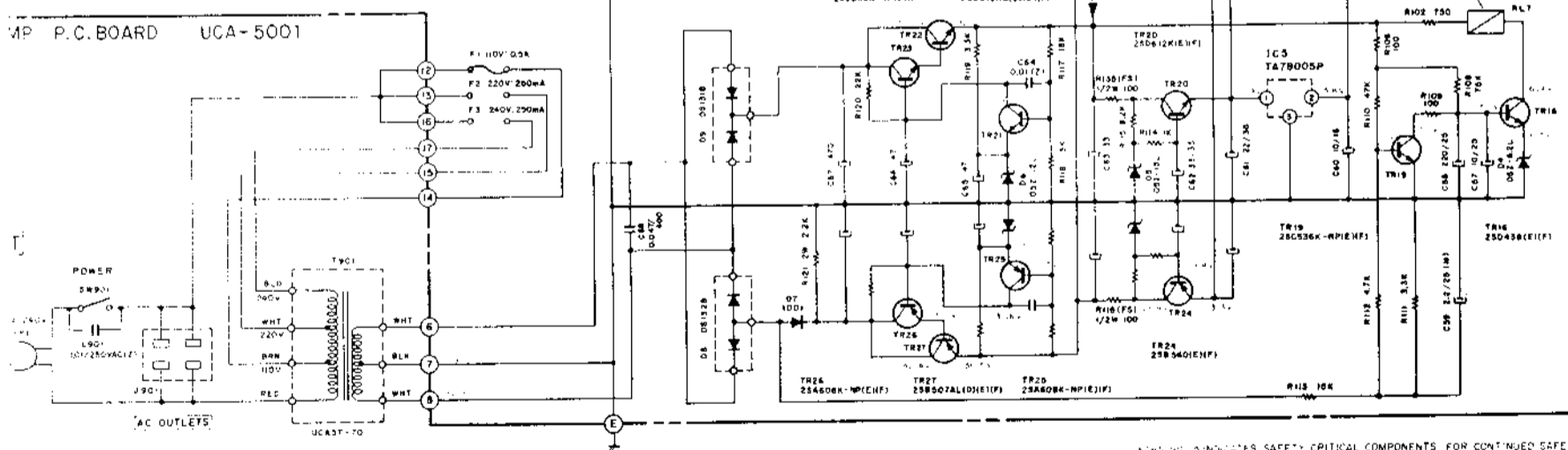

WAVE LINE INDICATES SAFETY CRITICAL COMPONENTS (FOR CONTINUED SAFETY).
 REPLACE SAFETY CRITICAL COMPONENTS ONLY WITH MANUFACTURER'S
 RECOMMENDED PARTS.
 LIGNE ONDE INDIQUE LES COMPOSANTS CRITIQUES DE SURETE POUR
 MAINTENIR LE DEGRÉ DE SURETE DE L'APPAREIL. NE REMPLACEZ LES
 COMPOSANTS QU'EN LE FONCTIONNEMENT EST CRITIQUE POUR LA SURETE
 ET POUR LES PIÉCES RECOMMANDÉES PAR LE FABRICANT.

NOTE
 UNLESS OTHERWISE SPECIFIED
 ALL RESISTORS IN OHMS (4W/1J)
 ALL CAPACITORS IN μ F 50 WV(J)
 (FS) = FAIL-SAFE RESISTORS
 (FP) = NON-POLAR CAPACITORS
 POWER TRANSFORMER IS DIFFERENT
 ACCORDING TO AREA

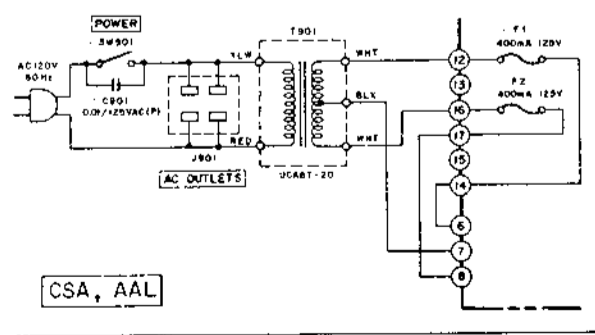
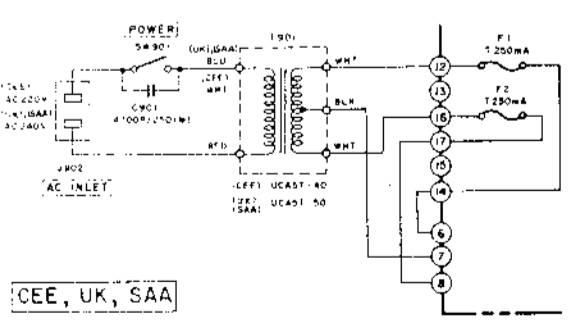

UC-A5
 SCHEMATIC DIAGRAM
 No. 1600640A

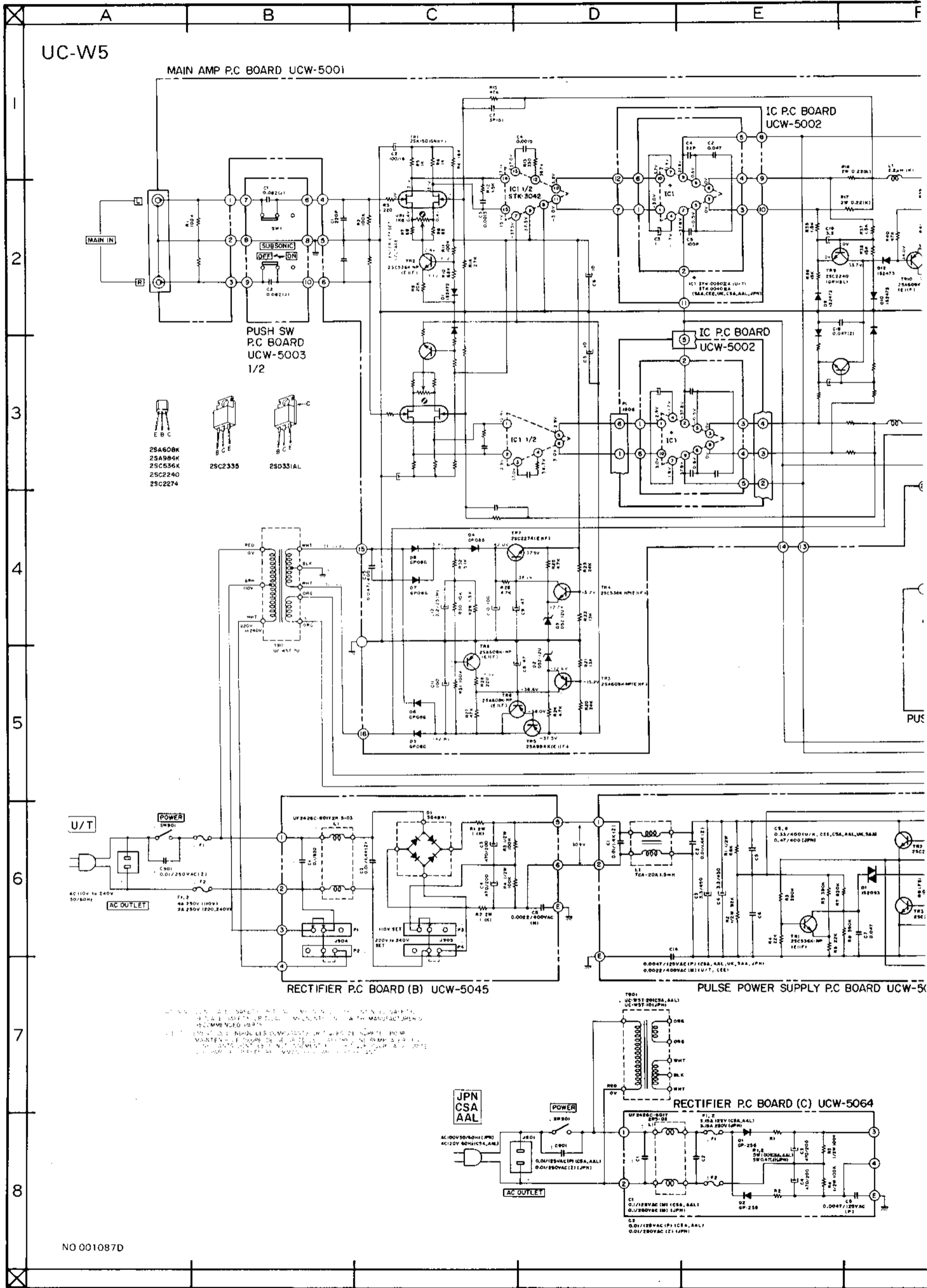

F G H I J K

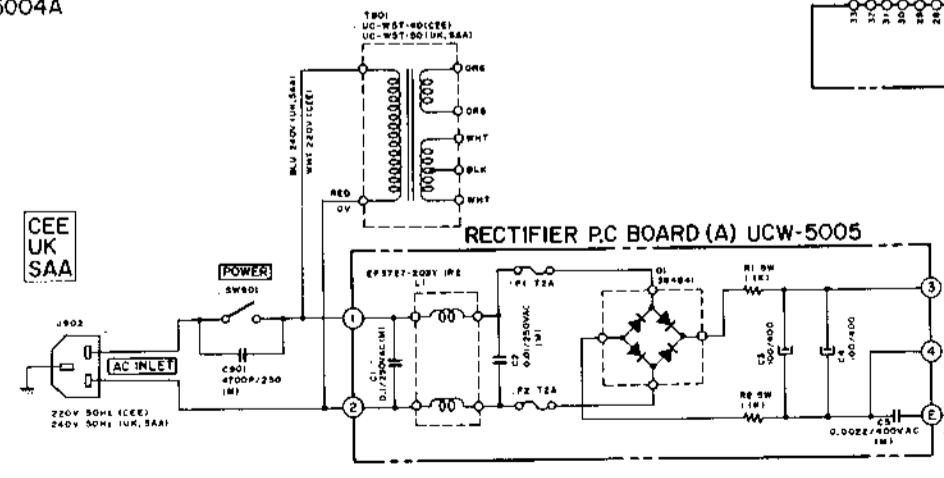
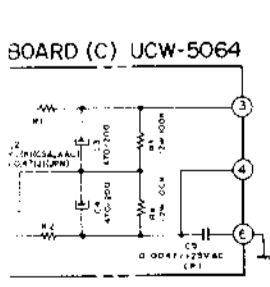
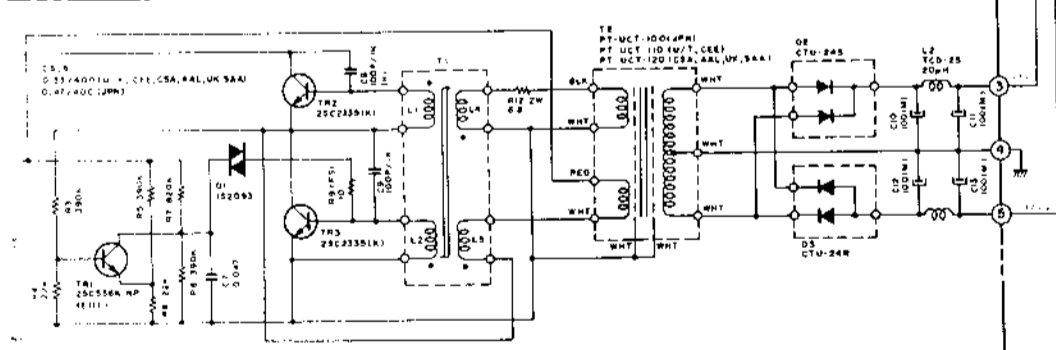
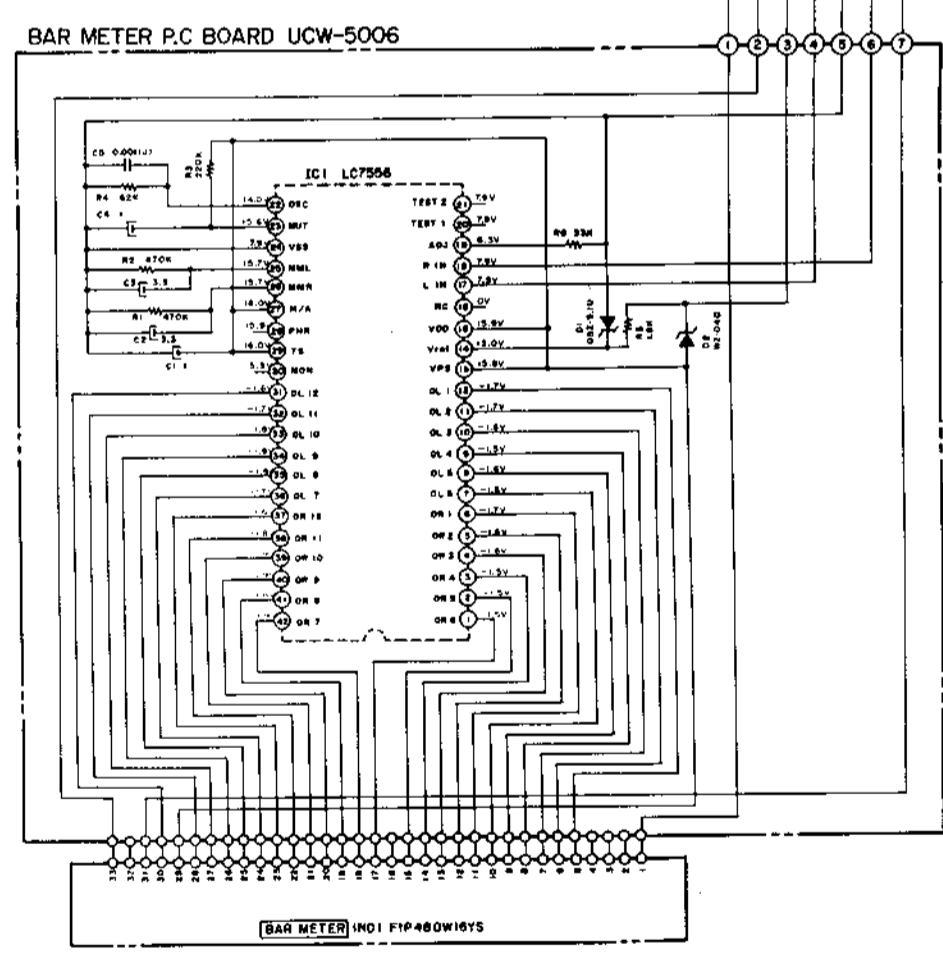
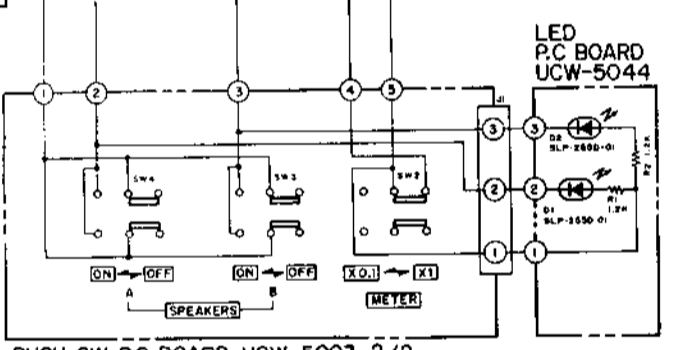
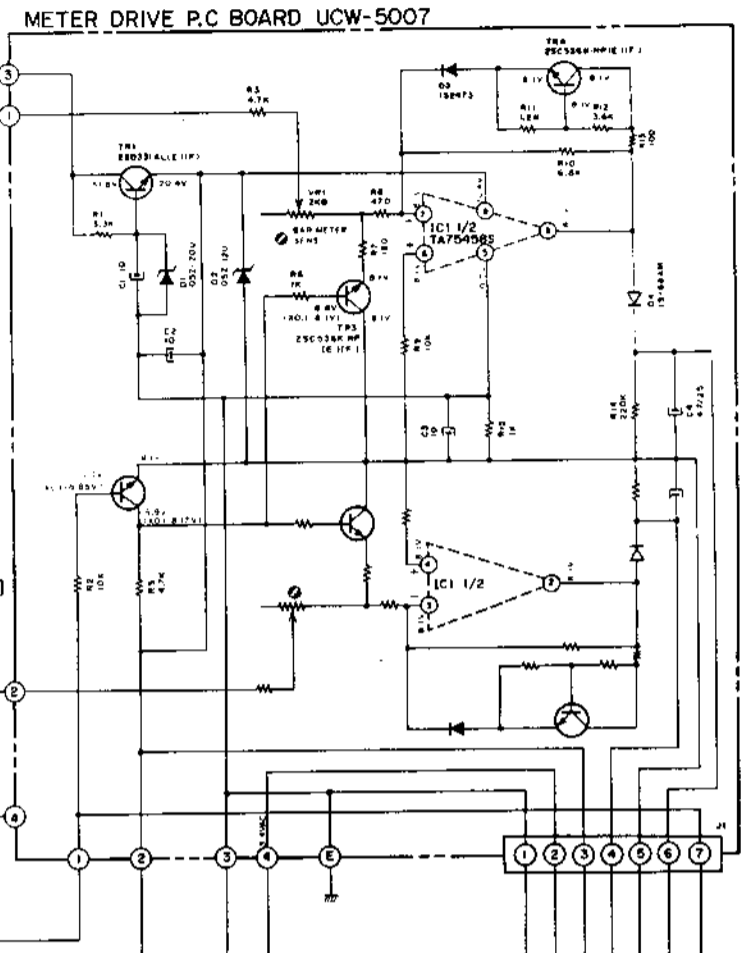
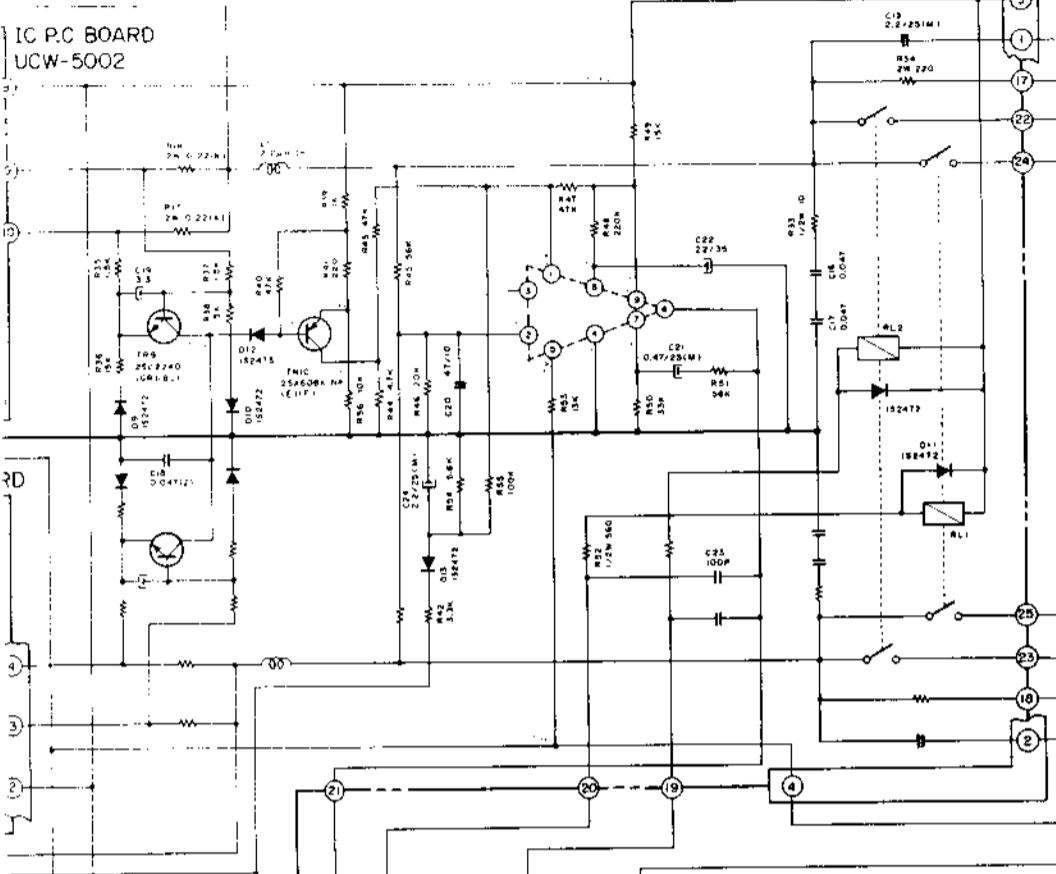

NOTE
 UNLESS OTHERWISE SPECIFIED
 ALL RESISTORS IN OHMS 1/4W(1)
 ALL CAPACITORS IN µF 50 WV(1)
 (FS) = FAIL SAFE RESISTORS
 (NP) = NON-POLAR CAPACITORS
 POWER TRANSFORMER IS DIFFERENT
 ACCORDING TO AREA

UC-W5
 SCHEMATIC DIAGRAM
 No.1600641A