

UC-K2
UC-U2
UC-M2

AKAI SERVICE MANUAL

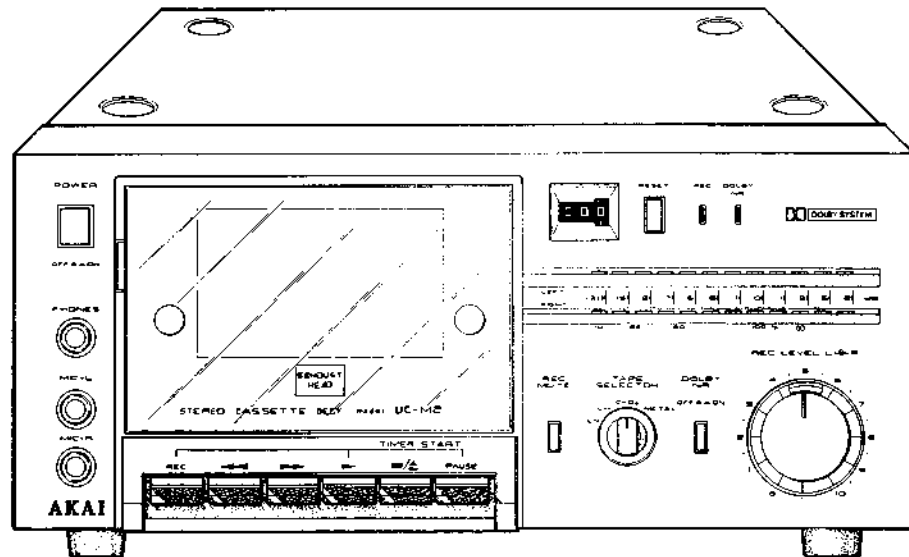
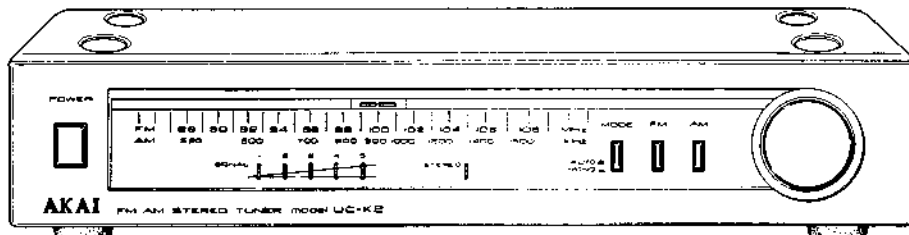
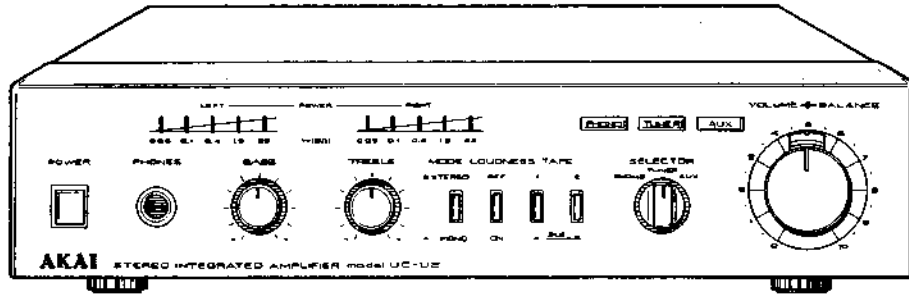

FM AM STEREO TUNER

MODEL **UC-K2**

STEREO INTEGRATED AMPLIFIER

MODEL **UC-U2**

STEREO CASSETTE DECK

MODEL **UC-M2**

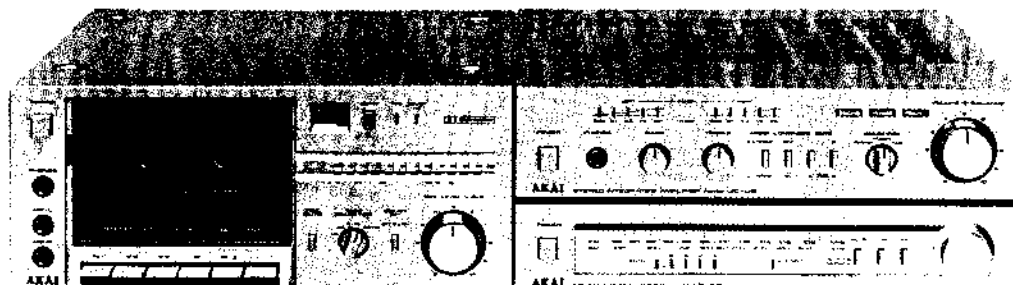

FM AM STEREO TUNER

MODEL UC-K2

STEREO INTEGRATED AMPLIFIER

MODEL UC-U2

STEREO CASSETTE DECK

MODEL UC-M2

ALSO APPLICABLE TO BLACK PANEL MODEL

TABLE OF CONTENTS

SECTION 1	MODEL UC-K2	3
SECTION 2	MODEL UC-U2	15
SECTION 3	MODEL UC-M2	29
SECTION 4	PARTS LIST	47
SECTION 5	SCHEMATIC DIAGRAM	78

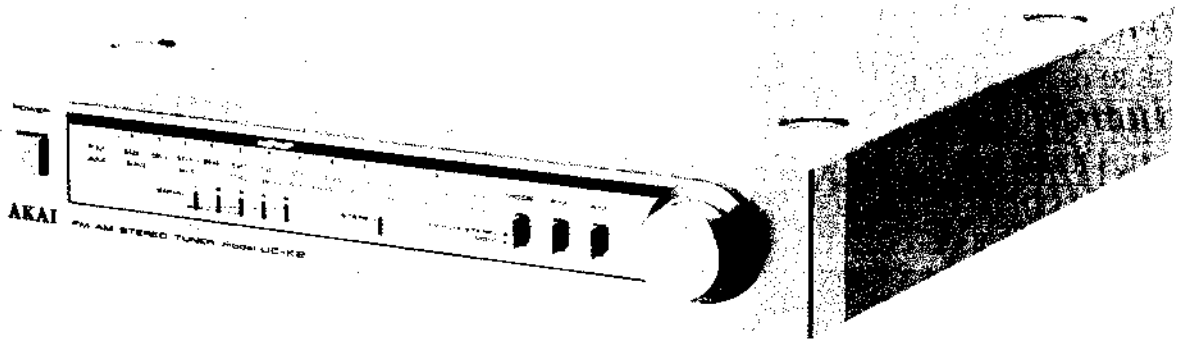

SECTION 1

FM AM STEREO TUNER

MODEL UC-K2

ALSO APPLICABLE TO BLACK PANEL MODEL

TABLE OF CONTENTS

I.	TECHNICAL DATA	4
II.	DISMANTLING OF UNIT	5
III.	CONTROLS	6
IV.	PRINCIPAL PARTS LOCATION	7
V.	VOLTAGE CONVERSION	8
VI.	TUNER ADJUSTMENT	9
	1. FM TUNER SECTION ADJUSTMENT	10
	2. AM TUNER SECTION ADJUSTMENT	12
VII.	CLASSIFICATION OF VARIOUS P.C. BOARDS	13
	1. P.C. BOARD TITLES AND IDENTIFICATION NUMBERS	13
	2. COMPOSITION OF VARIOUS P.C. BOARDS	14

For basic adjustments, measuring methods, and operating principles, refer to GENERAL TECHNICAL MANUAL.

I. TECHNICAL DATA

FM TUNER SECTION

FREQUENCY RANGE	88 MHz to 108 MHz 76 MHz to 90 MHz (Japan only)
SENSITIVITY (IHF)	1.9 μ V
CAPTURE RATIO	More than 1.5 dB
SELECTIVITY (IHF)	More than 55 dB
IMAGE REJECTION	More than 50 dB
IF REJECTION	More than 85 dB
SPERIOUS REJECTION	More than 60 dB
AM SUPPRESSION	50 dB
SIGNAL TO NOISE RATIO	67 dB
HARMONIC DISTORTION	MONO: Less than 0.15% (100% modulation) STEREO: Less than 0.3% (100% modulation)
FM FREQUENCY RESPONSE	20 Hz to 15,000 Hz +1 dB, -1 dB
MUTING	Switchable to ON - OFF
STEREO SEPARATION	More than 40 dB (1 kHz)
PILOT SIGNAL SUPPRESSION	More than 55 dB
SUB CARRIER SUPPRESSION	More than 55 dB
OUTPUT VOLTAGE	1 V (100% modulation)
ANTENNA INPUT IMPEDANCE	300 ohms balanced. 75 ohms unbalanced

AM TUNER SECTION

FREQUENCY RANGE	525 kHz to 1,605 kHz
SENSITIVITY (IHF)	250 μ V/m (Bar Antenna)
SELECTIVITY (IHF)	More than 30 dB
IMAGE REJECTION	More than 40 dB
IF REJECTION	More than 35 dB
SIGNAL TO NOISE RATIO	More than 40 dB
OUTPUT VOLTAGE	0.3 V (30% modulation)
ANTENNA	Built in ferrite bar antenna

MISCELLENEOUS

SEMICONDUCTORS	Transistors: 4, Diodes: 21, ICs: 10, LEDs: 8, FETs: 1
POWER REQUIREMENTS	100V, 50/60 Hz for Japan 120V, 60 Hz for USA and Canada 220V, 50 Hz for Europe except UK 240V, 50 Hz for UK and Australia 110/120/220/240V, 50/60 Hz internally switchable for other countries
POWER CONSUMPTION	12W for JPN, CSA. AAL, U/T Models
DIMENSIONS	280(W) x 56(H) x 303(D) mm (11.0 x 2.2 x 11.9) inches
WEIGHT	3.0 kg (6.6 lbs)

* For improvement purposes, specifications and design are subject to change without notice.

II. DISMANTLING OF UNIT

In case of trouble, etc. necessitating dismantling, please dismantle in the order shown in the photographs. Reassemble in reverse order.

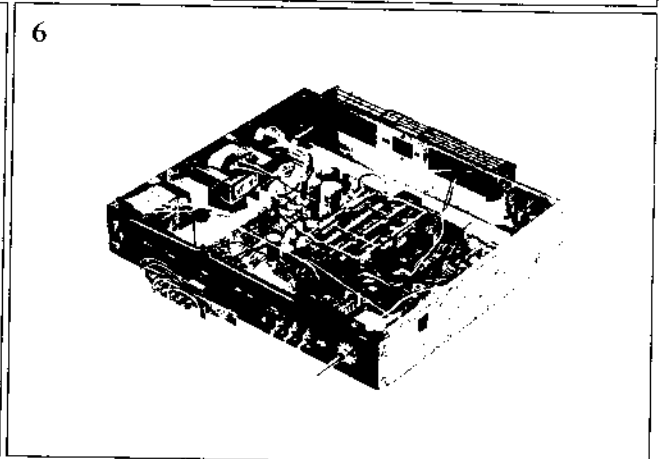
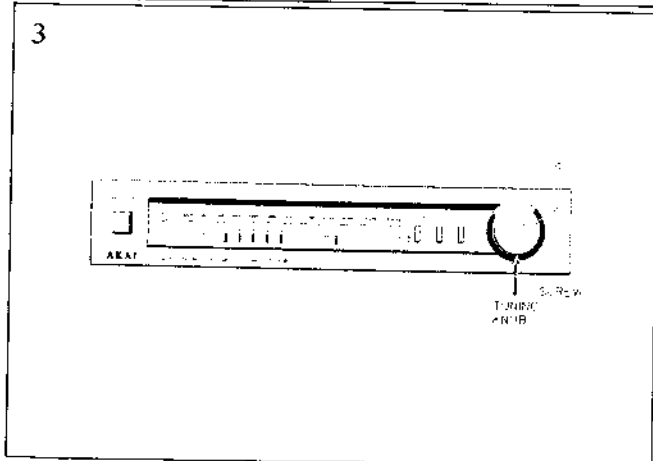
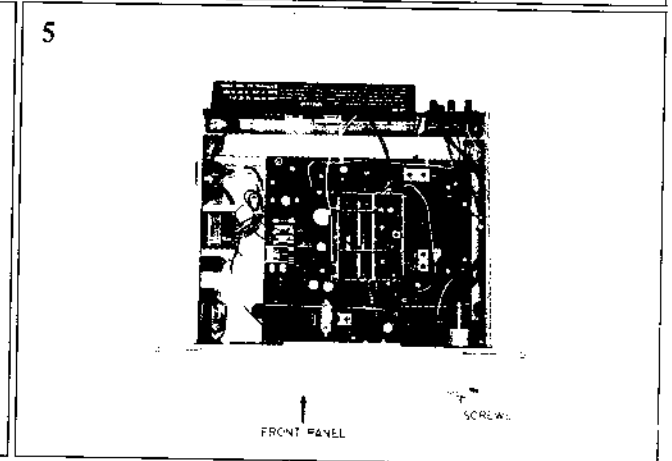
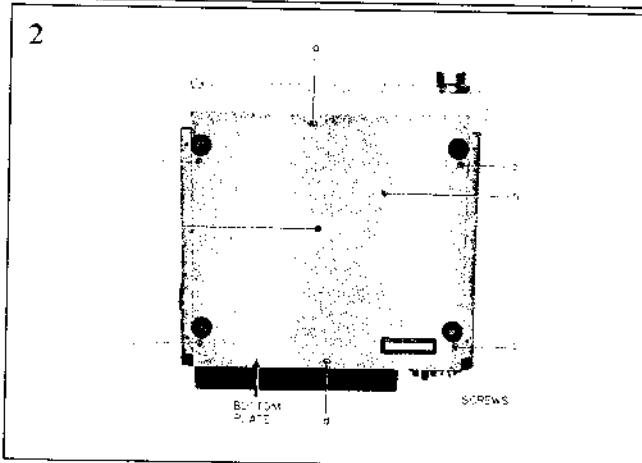
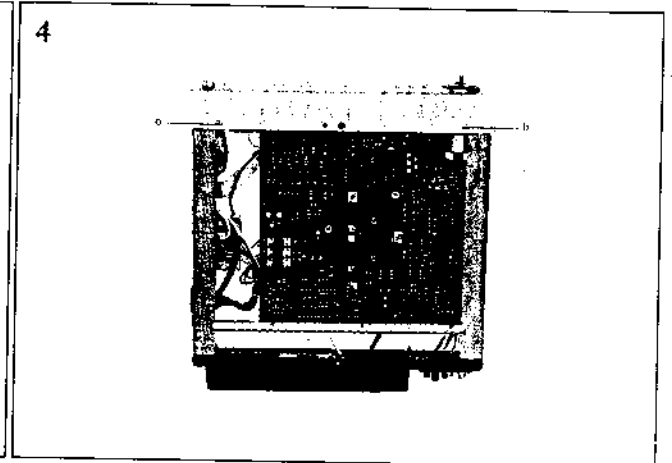
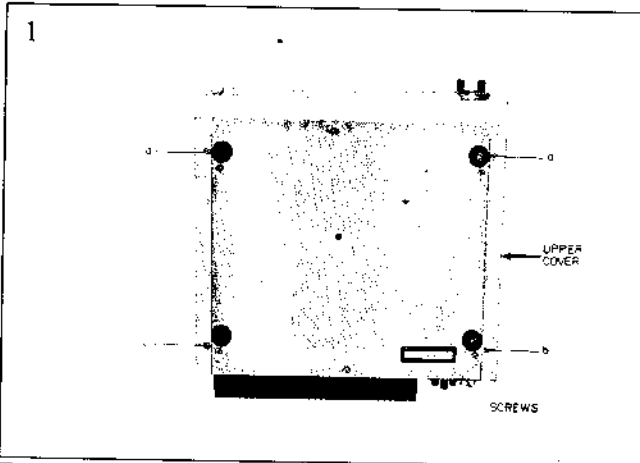

III. CONTROLS

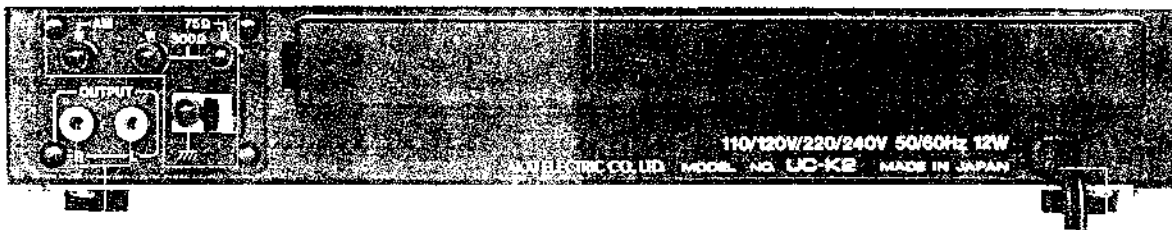
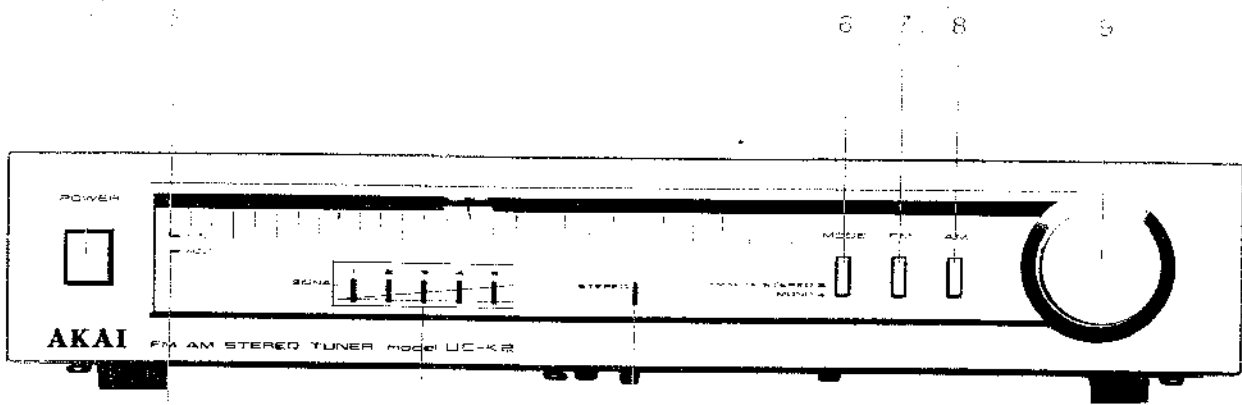

- | | |
|------------------------------|---------------------------------|
| 1. POWER SWITCH | 4. AM SWITCH |
| 2. AM DIAL SCALE | 5. TUNING KNOB |
| 3. FM DIAL SCALE | 10. FM and AM ANTENNA TERMINALS |
| 4. SIGNAL STRENGTH INDICATOR | 11. AM FERRITE BAR ANTENNA |
| 5. FM STEREO LAMP | 12. OUTPUT JACKS |
| 6. FM MODE SWITCH | 13. AC POWER CORD |
| 7. FM SWITCH | |

IV. PRINCIPAL PARTS LOCATION

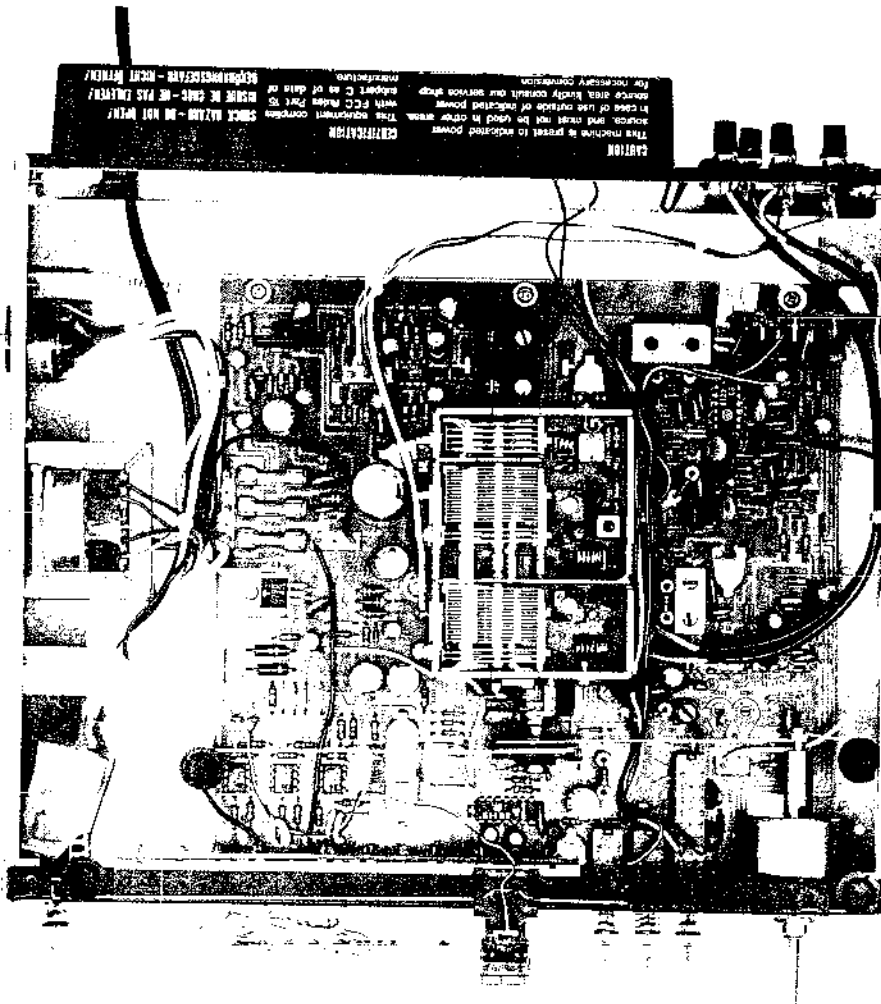

AFC
PC BOARD
72-621

V. VOLTAGE CONVERSION

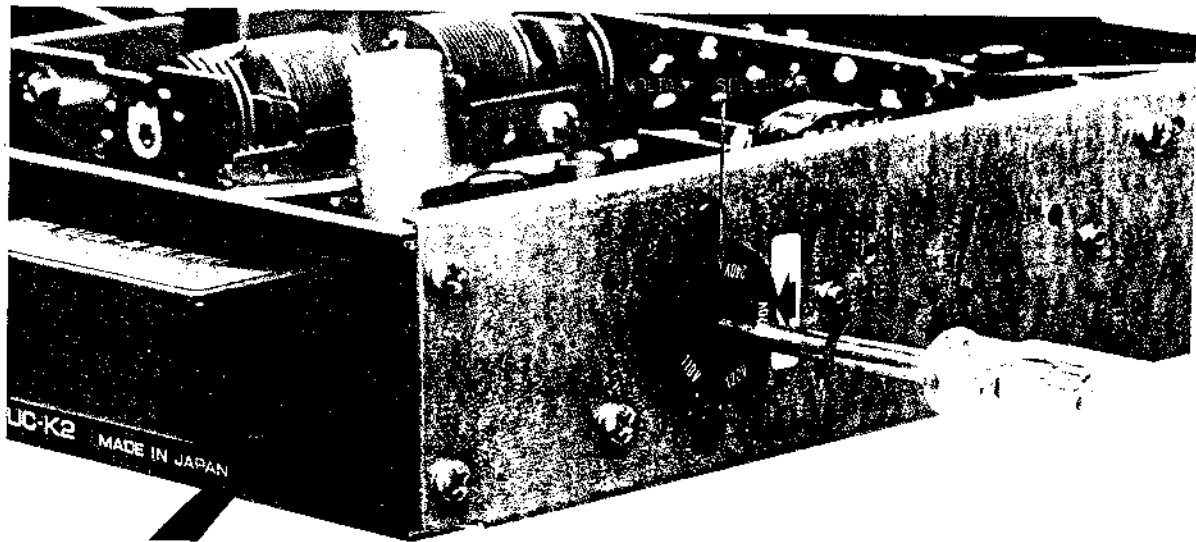

Fig. 5 Voltage Conversion (U.T. Model)

Models for Canada, USA, Australia, Japan, and Europe, are now equipped with this facility. This machine can be set to 110V, 120V, 220V or 240V as required. Each machine is preset at the factory according to destination. However, if voltage change is necessary, this can be accomplished by a qualified service personnel as follows:

1. Disconnect power cord.
2. Loosen holding screws and remove top panel.
3. With a flat bladed screwdriver rotate the selector located on the left hand side (Power Switch side), until the arrow points to the desired voltage.

VI. TUNER ADJUSTMENT

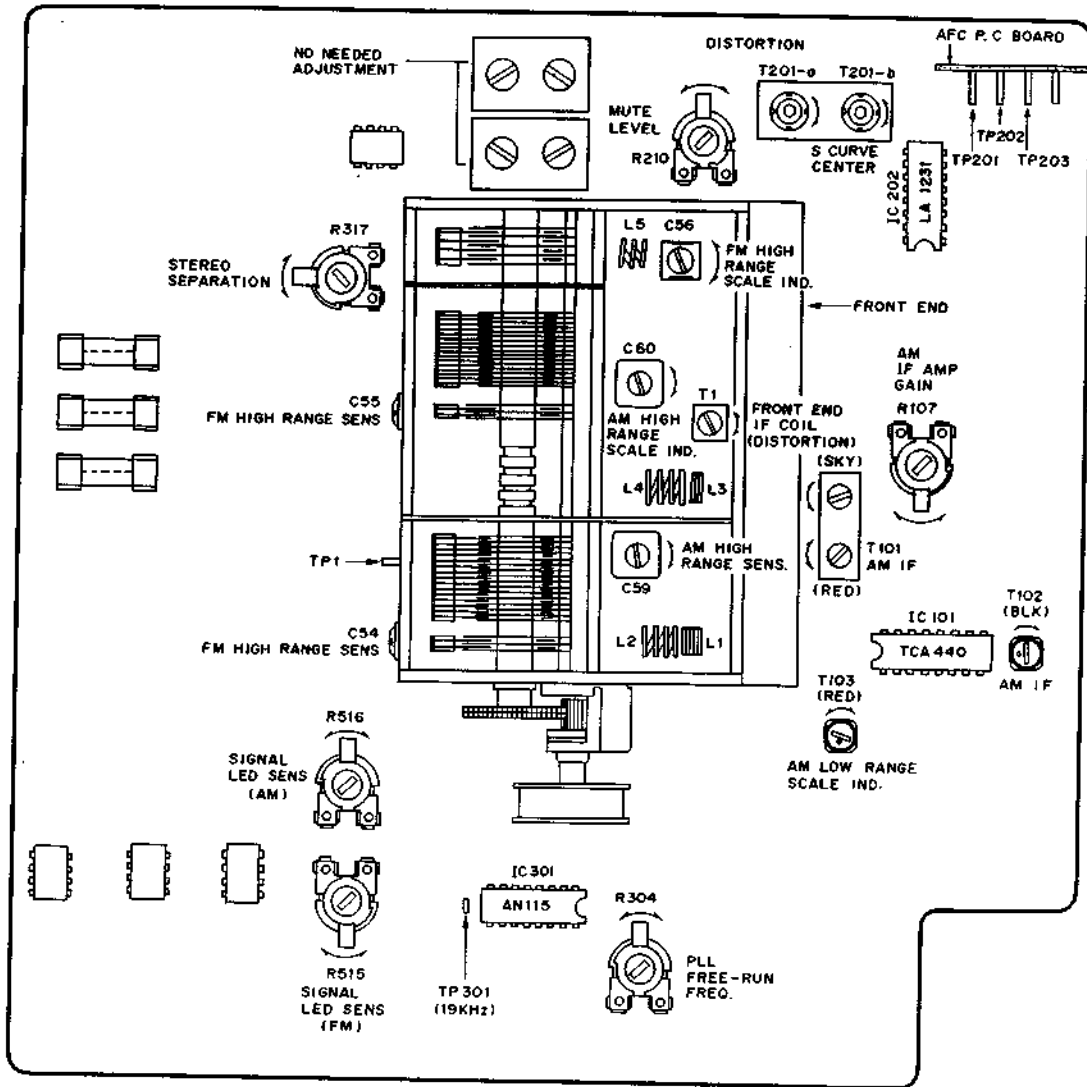

Fig. 4 Tuner P.C Board

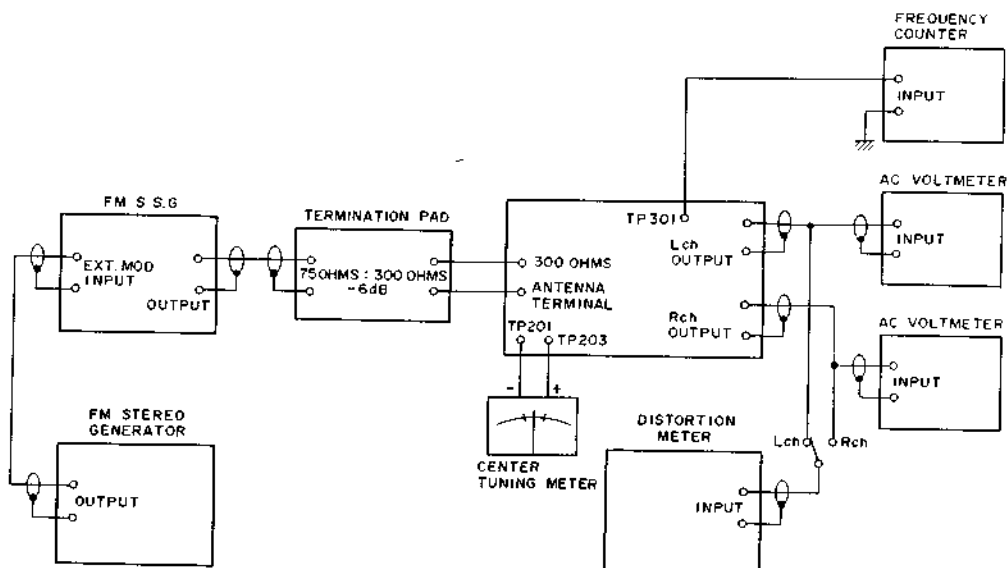

Fig. 5 Instrument Connections

1. FM TUNER SECTION ADJUSTMENT (Refer to Figs. 4, 5)

Step	Adjustment Item	Adjustment Point	Result	Remarks
1	Front End IF Coil	T1 (Front End)	Maximum Noise Level	Selector to FM, and Mode to MONO. Detune and receive only interstation noise.
2	S Curve Center	T201-b	Centered Tuning Meter Indication	Connect a Center Tuning Meter between TP201 and TP203. 98 MHz (Japan: 83 MHz) 60 dB (mono) input. Refer to NOTE 1
3	Distortion Factor	T201-a T1 (Front End)	Less than 0.15% Distortion Factor	98 MHz (Japan: 83 MHz) 60 dB (mono) input. Modulation: 1 kHz, 100%
4	Readjust in steps 2 and 3.			
5	High Range Scale Indication	C56 (Front End)	Maximum Output Minimum Distortion Factor	108 MHz (Japan: 90 MHz) 60 dB (mono) input. Modulation: 1 kHz, 100% Scale indicator to 108 MHz (Japan: 90 MHz) Error: within ± 250 kHz
6	Confirmation of Low Range Scale Indication		Maximum Output Minimum Distortion Factor	88 MHz (Japan: 76 MHz) 60 dB (mono) input. Modulation: 1 kHz, 100% Scale Indicator to 88 MHz (Japan: 76 MHz) Error: within ± 250 kHz
7	High Range Sensitivity	C54, C55 (Front End)	Less than 3% Distortion Factor	108 MHz (Japan: 90 MHz), Better than 6 dB (mono) input. Modulation: 1 kHz, 100%
8	Confirmation of Low Range Sensitivity		Less than 3%	88 MHz (Japan: 76 MHz), Better than 6 dB (mono) Modulation: 1 kHz, 100%
9	Signal LED Sensitivity	R515 (50 k)	<ol style="list-style-type: none"> 1. Detune then turn R515 (50 k) and temporarily light Signal LED 1. 2. Turn R515 (50 k) in clockwise direction until LED 1 goes out. 3. Input 98 MHz (Japan: 83 MHz), 60 to 80 dB and check that Signal LED 5 lights. 	
10	FM Mute Level	R210 (50 k)	Mode Switch to STEREO. 98 MHz (Japan: 83 MHz) 30 dB input. Adjust R210 (50 k) to the point where the output signal appears.	
11	PLL MPX Free Running Frequency	R304 (10 k)	19.00 kHz	Connect Frequency Counter between TP301 and Ground 98 MHz (Japan: 83 MHz) Modulation: not
12	Confirmation of STEREO Indicator indicator Lighting		Must be lighted	98 MHz (Japan: 83 MHz) 60 dB (stereo) input. Modulation: 1 kHz, 100%, only light channel

Step	Adjustment Item	Adjustment Point	Result	Remarks
13	Stereo Separation (Left to Right)	R317 (50 k)	More than 40 dB	98 MHz (Japan: 83 MHz) 60 dB (stereo) input. Modulation: 1 kHz, 100% only Left channel
14	Stereo Separation (Right to Left)	R317 (50 k)	More than 40 dB	98 MHz (Japan: 83 MHz) 60 dB (stereo) input. Modulation: 1 kHz, 100% only Right channel

Chart-1

NOTE: For the center meter, use a tuning meter supplied as parts for other models.

Step	Adjustment Item	Adjustment Point	Result	Remarks
1	IF Amp Gain	R107 (1 k)	50 mV (OUTPUT)	Selector to AM. 600 kHz, 34 dB from SSG to TP1 input. Modulation: 1 kHz, 30%
2	Low Range Scale Indication	T103 (RED)	Maximum Output	530 kHz 50 dB input. Scale indicator to 530 kHz. Error: within 2%
3	Low Range Sensitivity	T101, T102 (IF) Bar Antenna Coil	Maximum Output Minimum Distortion Factor	530 kHz 50 dB input. Less than 10% Distortion Factor
4	High Range Scale Indication	C60 (Front End)	Maximum Output	1600 kHz 50 dB input. Scale indicator to 1600 kHz. Error: within 2%
5	High Range Sensitivity	C59 (Front End)	Maximum Output Minimum Distortion Factor	1600 kHz 50 dB input. Less than 10% Distortion Factor
6	Signal LED Sensitivity	R516 (50 k)		<ol style="list-style-type: none"> 1. Detune, then turn R516 (50 k) and temporarily light Signal LED 1. 2. Turn R516 (50 k) in counterclockwise direction until LED 1 goes out. 3. Input 1000 kHz, 90 to 120 dB from the AM ANT terminal and check that signal LED 4.

Chart-2

NOTE: For the best results, repeat Steps 1 through 5 two or three times.

2. AM TUNER SECTION ADJUSTMENT

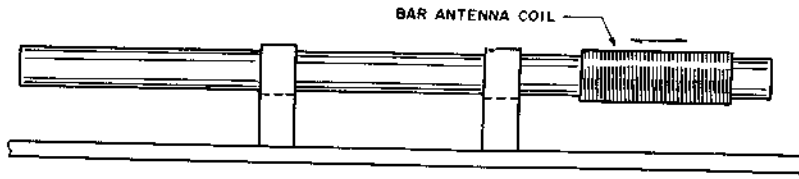
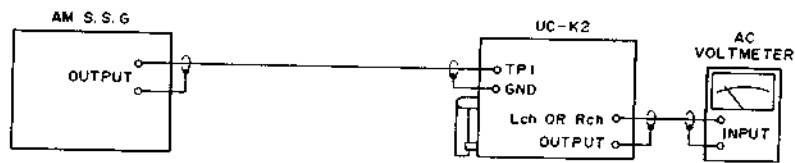
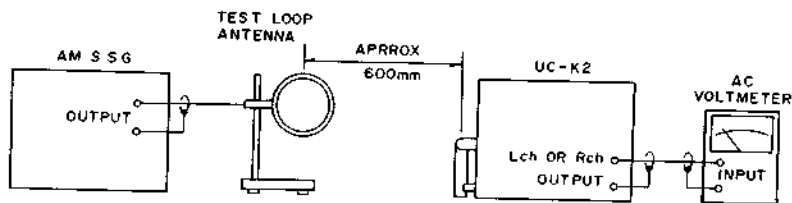

Fig. 6 Bar Antenna

NOTE: The Bar Antenna coil need only be adjusted if the measured result lies outside the specified range.



(a) Step 1



(b) Steps 2 to 5

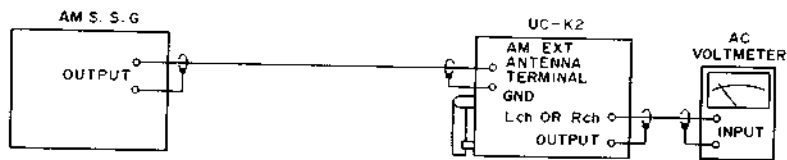

(c) Step 6

Fig. 7 Instrument Connections

VII. CLASSIFICATION OF VARIOUS P.C BOARDS

1. P.C BOARD TITLES AND IDENTIFICATION NUMBERS

P.C Board Title	P.C Board Number
Tuner P.C Board	72-1859
LED Ind. P.C Board	72-1860
Lamp Ind. P.C Board	72-1861
Power Switch P.C Board	72-1873
AFC P.C Board	72-1927
Dial Pointer P.C Board	72-1862

Chart-3

2. COMPOSITION OF VARIOUS P.C BOARDS

TUNER P.C BOARD 72-1859, AFC P.C BOARD 72-1927, LED IND. P.C BOARD 72-1860, LAMP IND. P.C BOARD 72-1861 and POWER SWITCH P.C BOARD 72-1873

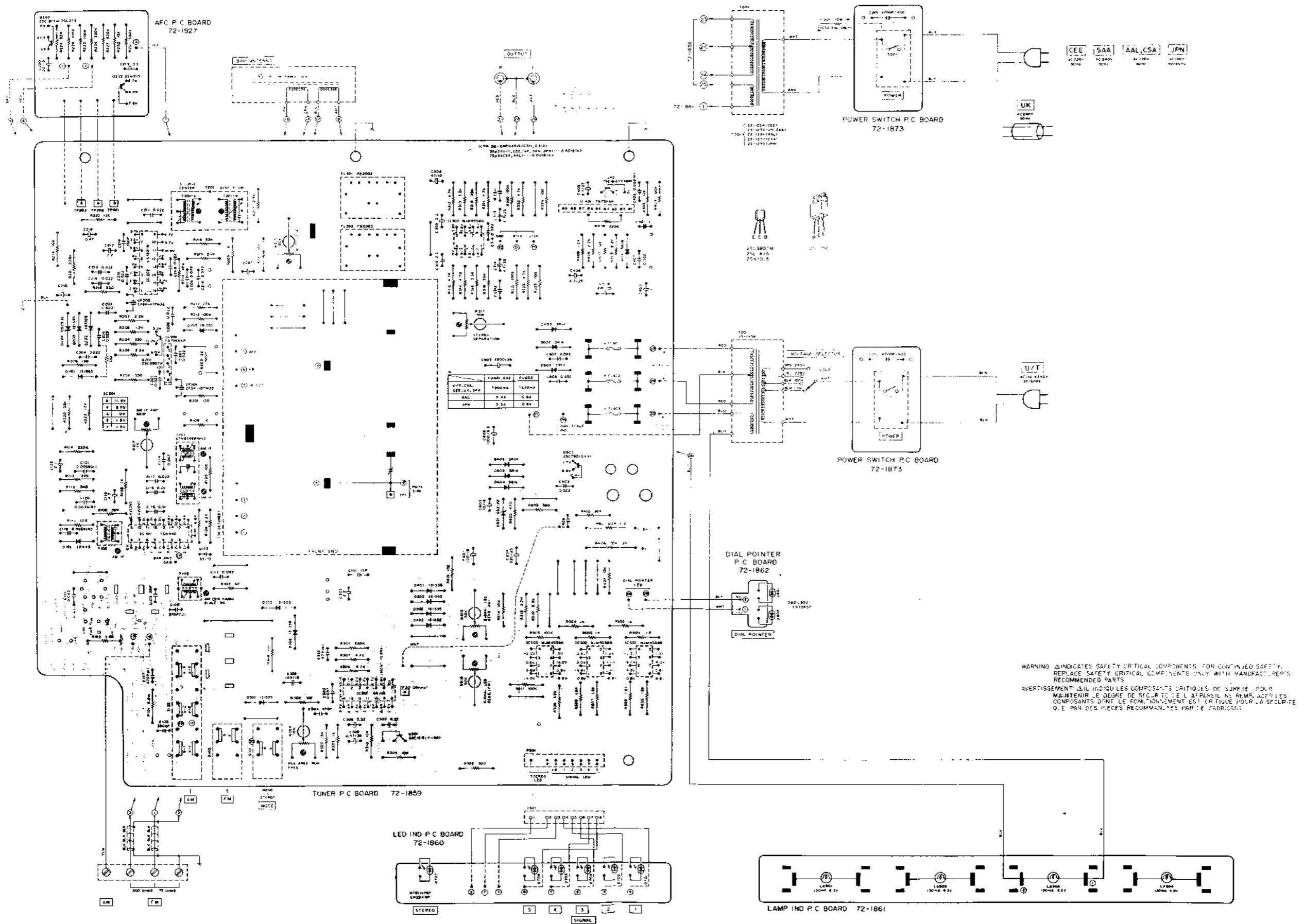

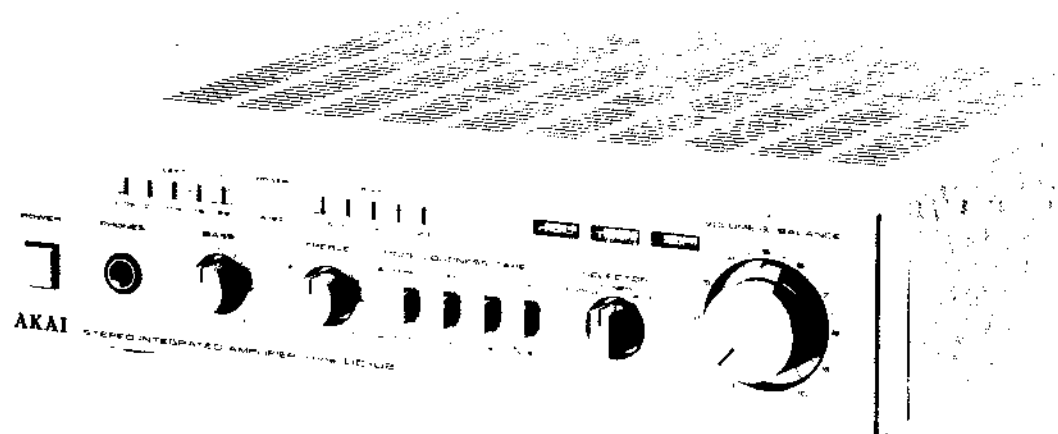

SECTION 2

STEREO INTEGRATED AMPLIFIER

MODEL UC-U2

ALSO APPLICABLE TO BLACK PANEL MODEL

TABLE OF CONTENTS

I.	TECHNICAL DATA	16
II.	DISMANTLING OF UNIT	17
III.	CONTROLS	18
IV.	PRINCIPAL PARTS LOCATION	19
V.	VOLTAGE CONVERSION	20
IV.	LEVEL DIAGRAM	21
VII.	AMPLIFIER ADJUSTMENT	22
	1. IDLING CURRENT ADJUSTMENT	22
	2. LEVEL METER ADJUSTMENT	23
VIII.	CLASSIFICATION OF VARIOUS P.C BOARDS	24
	1. P.C BOARD TITLES AND IDENTIFICATION NUMBERS	24
	2. COMPOSITION OF VARIOUS P.C BOARDS	25

For basic adjustments, measuring methods, and operating principles, refer to GENERAL TECHNICAL MANUAL.

I. TECHNICAL DATA

RATED POWER OUTPUT (2-Channel Driven)	23 watts per channel, minimum RMS, at 8 ohms from 20 to 20,000 Hz with no more than 0.06% total harmonic distortion
POWER BANDWIDTH (IHF)	10 Hz to 40 kHz/8 ohms (Total harmonic distortion: 0.06%)
SIGNAL TO NOISE RATIO (IHF)	PHONO: Better than 75 dB AUX: Better than 90 dB
RESIDUAL NOISE	Less than 0.6 mV at 8 ohms
CHANNEL SEPARATION (IHF)	PHONO: Better than 50 dB at 1,000 Hz AUX: Better than 55 dB at 1,000 Hz
DAMPING FACTOR	More than 40 (1 kHz, 8 ohms)
OUTPUT	Speakers: A, (4 to 16 ohms) Headphone: 8 to 200 ohms
INPUT SENSITIVITY/IMPEDANCE	PHONO: 3 mV/47 kohms AUX: 150 mV/47 kohms TUNER: 150 mV/47 kohms TAPE: PIN: 150 mV/47 kohms
OUTPUT LEVEL/IMPEDANCE	Tape Rec: PIN: 150 mV/5 kohms
FREQUENCY RESPONSE	PHONO: 30 Hz to 15 kHz, +1 dB, -1 dB (RIAA) AUX: 10 Hz to 50 kHz, +1 dB, -2 dB
TONE CONTROL	Bass: ±10 dB at 100 Hz Treble: ±10 dB at 10 kHz
LOUDNESS CONTROL	+10 dB at 100 Hz, +6 dB at 10 kHz
SEMICONDUCTORS	Transistors: 20, Diodes: 19, ICs: 4, LEDs: 10
POWER REQUIREMENTS	100V, 50/60 Hz for Japan 120V, 60 Hz for USA and Canada 220V, 50 Hz for Europe except UK 240V, 50 Hz for UK and Australia 110/120/220/240V, 50/60 Hz internally switchable for other countries
POWER CONSUMPTION	70W for JPN Model 88W for AAL Model 145W for CSA, U/T Models
DIMENSIONS	280(W) × 69(H) × 280(D) mm (11.0 × 2.7 × 11.0 inches)
WEIGHT	4.5 kg (9.7 lbs)

* For improvement purposes, Specifications and design are subject to change without notice.

II. DISMANTLING OF UNIT

In case of trouble, etc. necessitating dismantling, please dismantle in the order shown in the photographs. Reassemble in reverse order.

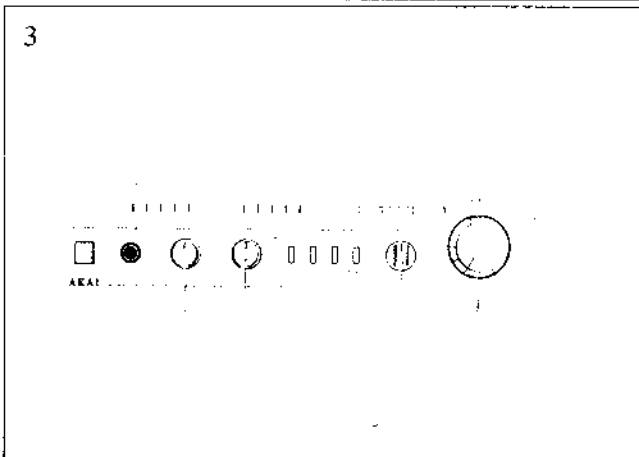
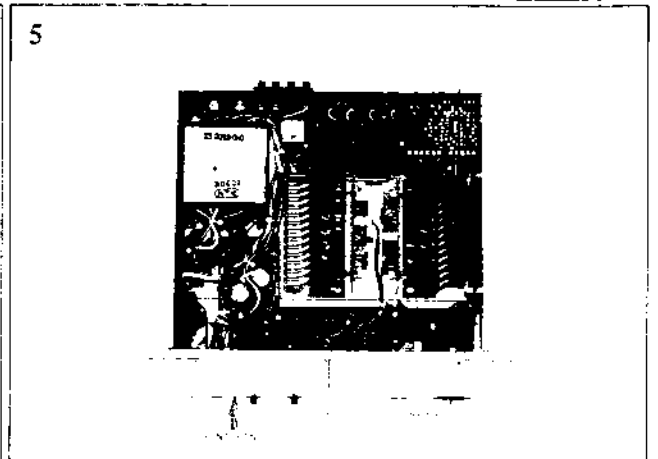
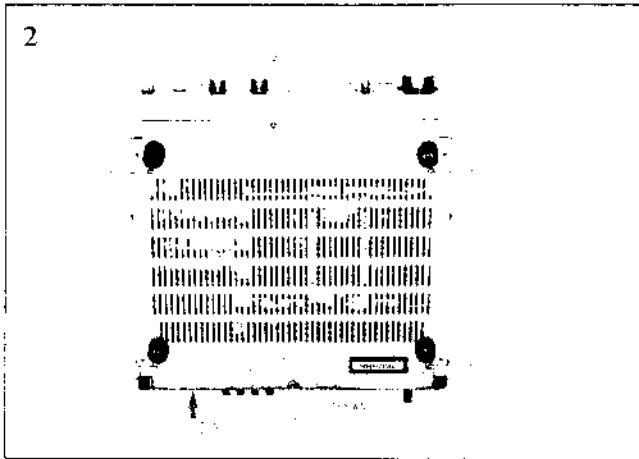
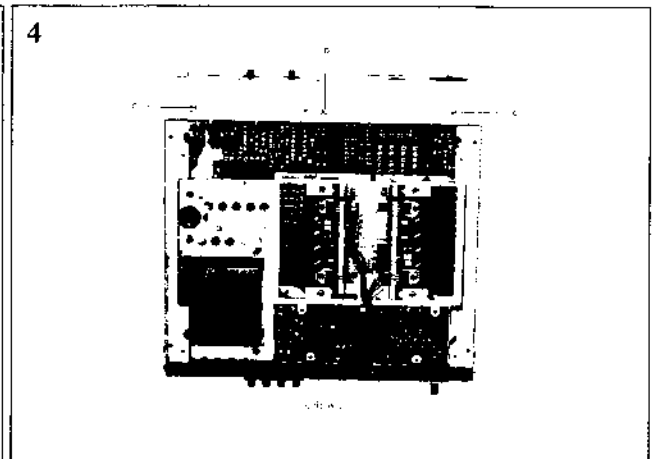
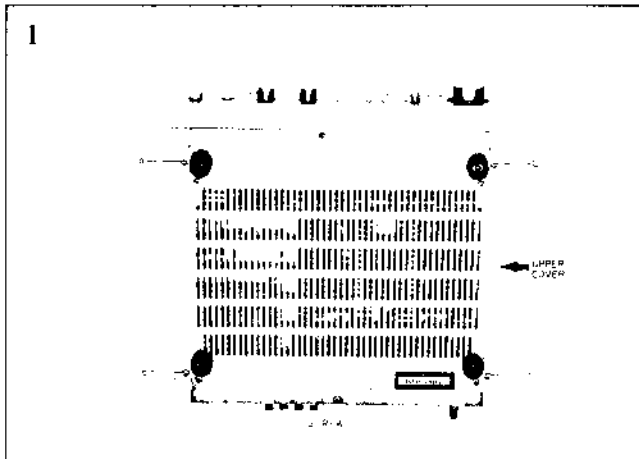

III. CONTROLS

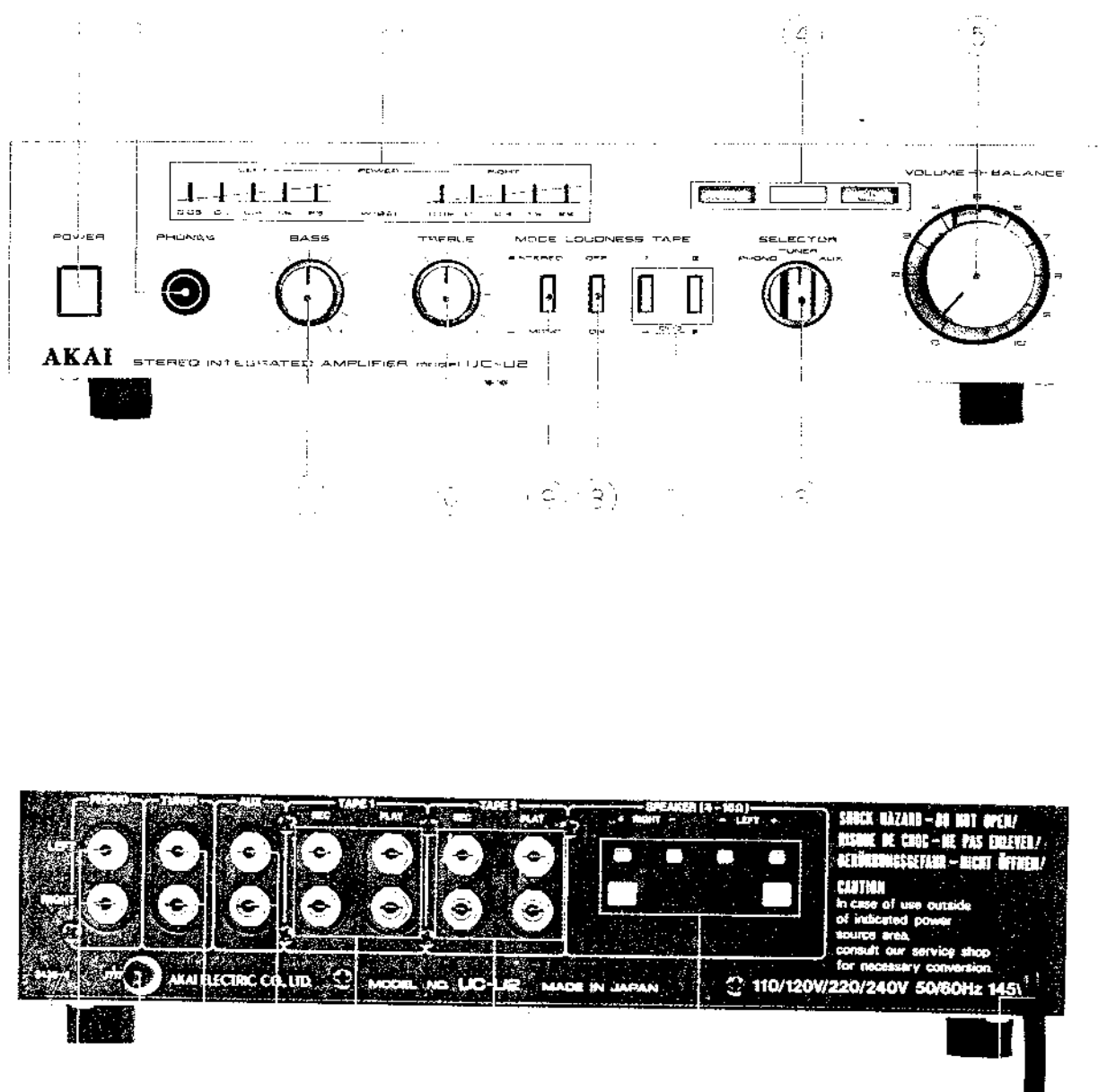

Fig 1. Controls

- | | |
|--|----------------------------------|
| 1. POWER SWITCH | 11. BASS CONTROL |
| 2. PHONO JACK | 12. PHONO JACKS |
| 3. POWER OUTPUT LED's (left and right) | 13. GROUND TERMINAL |
| 4. INPUT INDICATORS | 14. TUNER JACKS |
| 5. VOLUME • STEREO BALANCE CONTROL | 15. AUX JACKS |
| 6. INPUT SELECTOR | 16. TAPE 1 SYSTEM REC/PLAY JACKS |
| 7. TAPE MONITOR SWITCH | 17. TAPE 2 SYSTEM REC/PLAY JACKS |
| 8. LOUDNESS SWITCH | 18. SPEAKER TERMINALS |
| 9. MODE SWITCH | 19. AC POWER CORD |
| 10. TREBLE CONTROL | |

IV. PRINCIPAL PARTS LOCATION

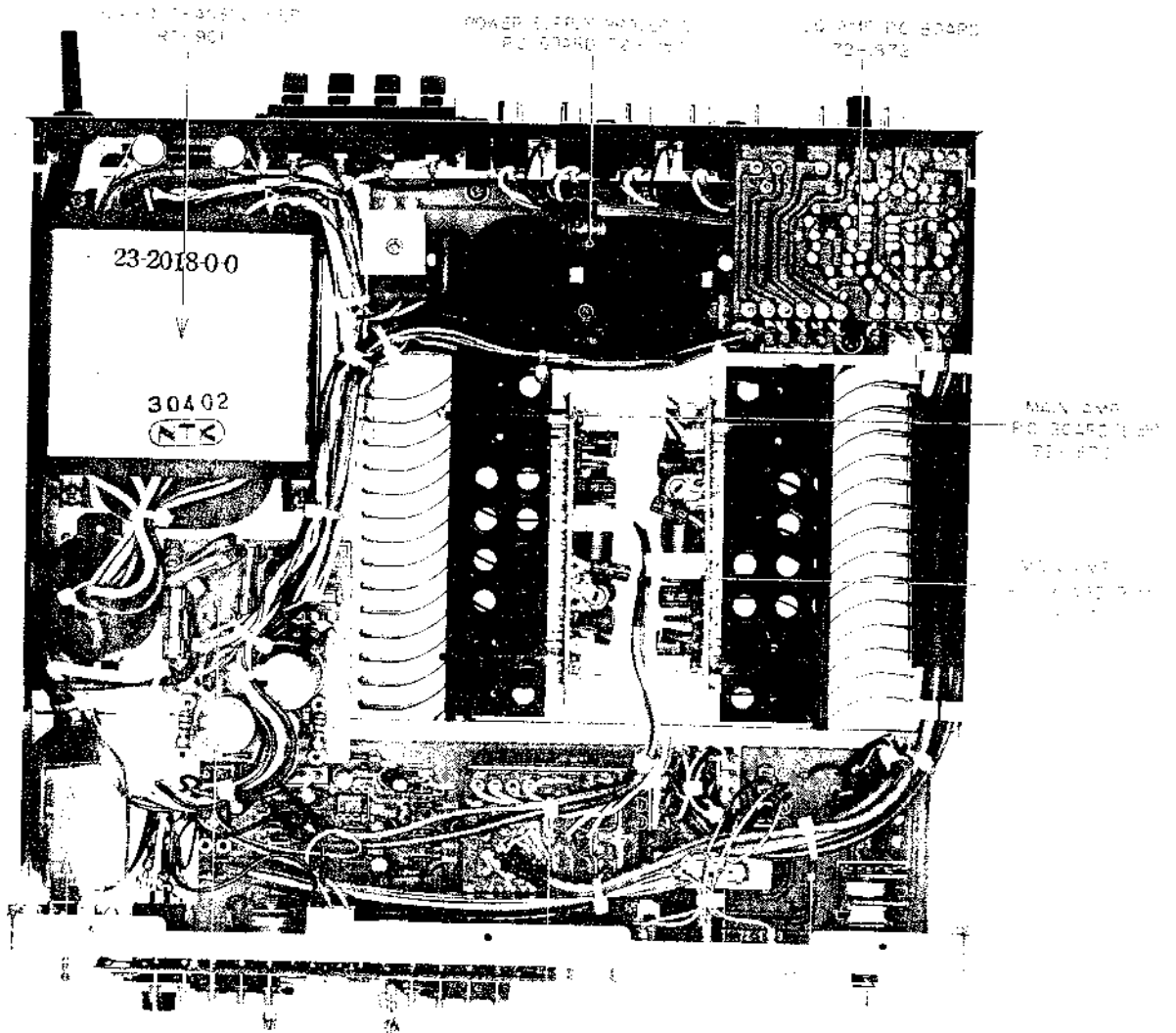

Fig. 2 - Front View

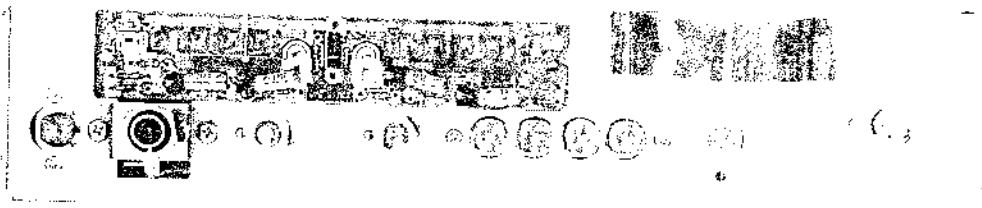
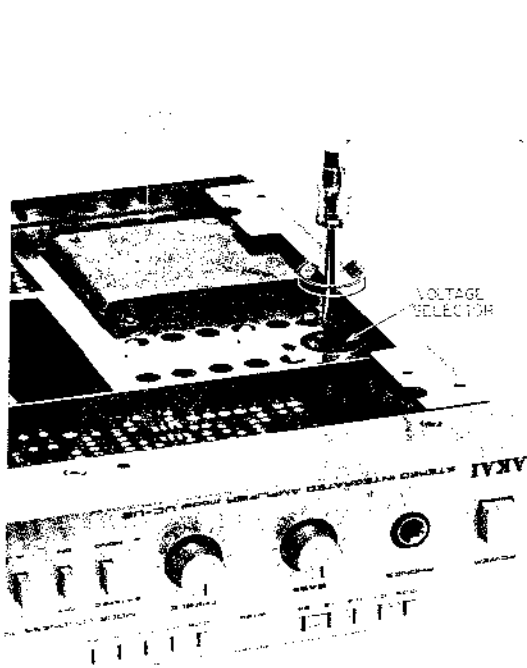
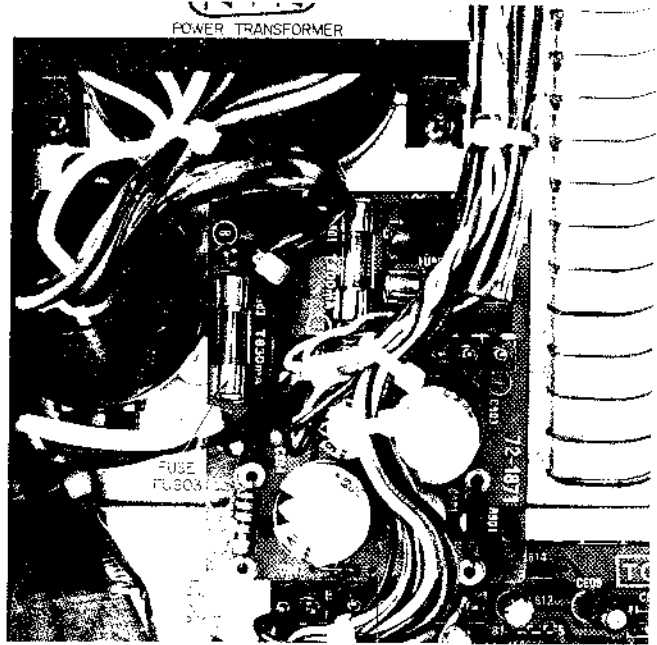

Fig. 3 - Front View

V. VOLTAGE CONVERSION



(a) Bottom View



(b) Top View

Fig. 4 Voltage Conversion

Models for Canada, USA, Australia, Japan and Europe are not equipped with this facility.

This machine can be set to 110V, 120V, 220V or 240V as required. Each machine is preset at the factory according to destination. However, if voltage change is necessary, this can be accomplished as follows.

1. Disconnect power cord.
2. Loosen holding screws and remove bottom and upper cover.
3. Turn the voltage selector until the arrow points to the correct voltage for your area with a minus screwdriver.
4. Change the fuse (F1:903): T1.6A for 110V to 120V and T630 mA for 220V to 240V.

IV. LEVEL DIAGRAM

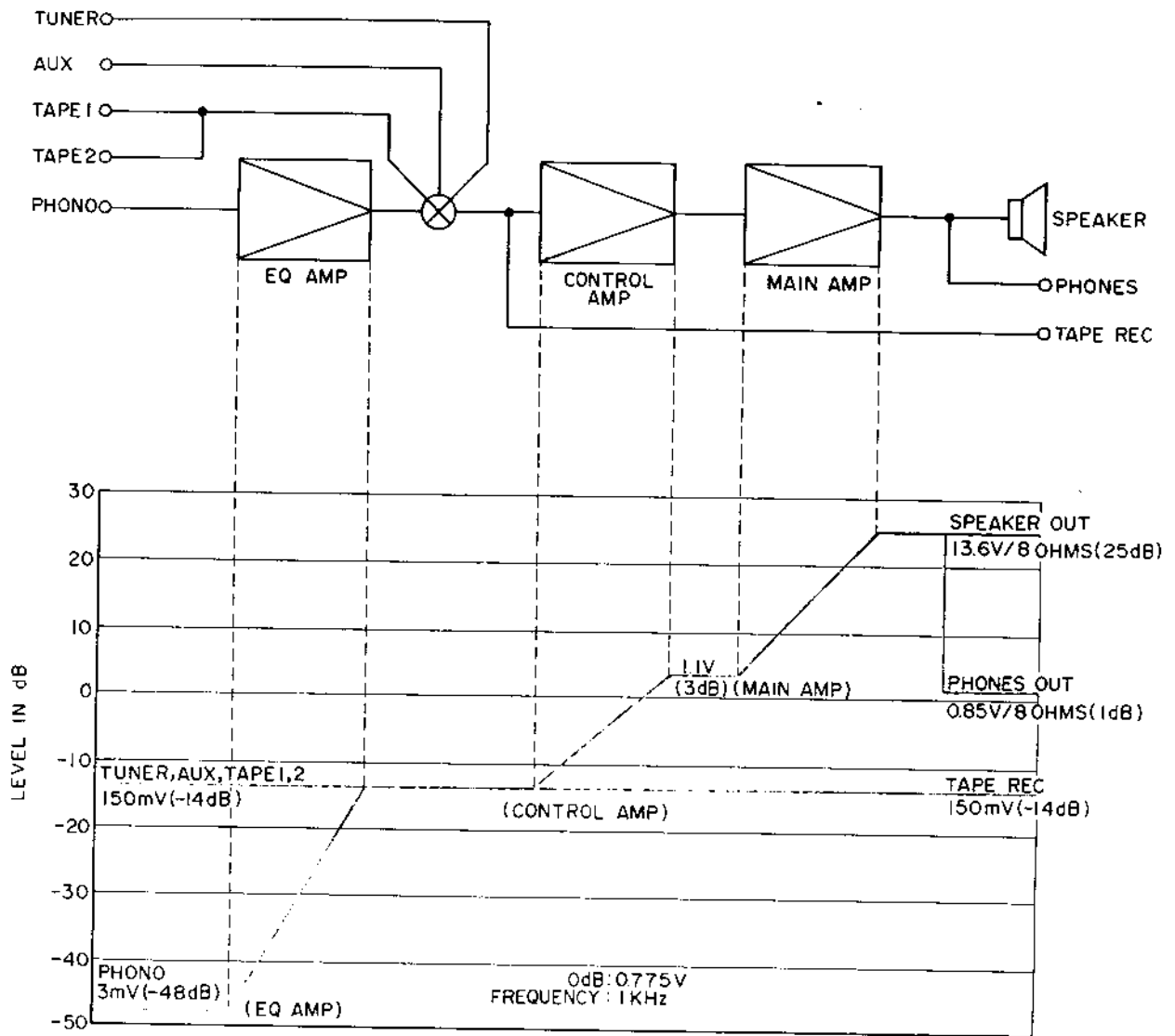

Fig. 5 Level Diagram

VII. AMPLIFIER ADJUSTMENT

1. IDLING CURRENT ADJUSTMENT

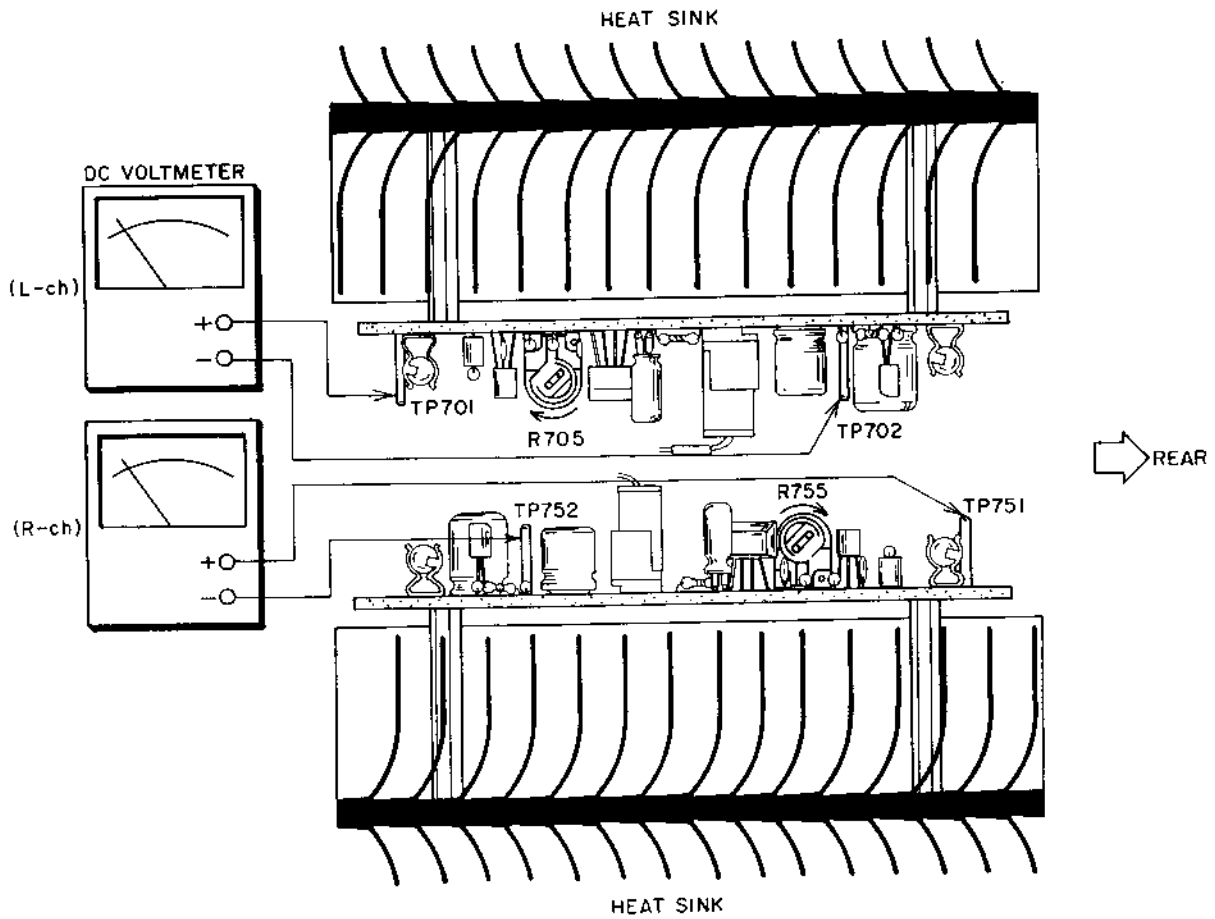

Fig. 6 Idling Current Adjustment Instrument Connections

Step	Adjustment Item	Adjustment Point	Result	Remarks
1	Idling Current (Left Channel)	R705 (1 k)	13 mV	Use a DC Voltmeter or Digital Voltmeter. (The idling current should be 13 mA.)
2	Idling Current (Right Channel)	R755 (1 k)	13 mA	

Chart-1

* Set VOLUME Control to Minimum.

2. LEVEL METER ADJUSTMENT

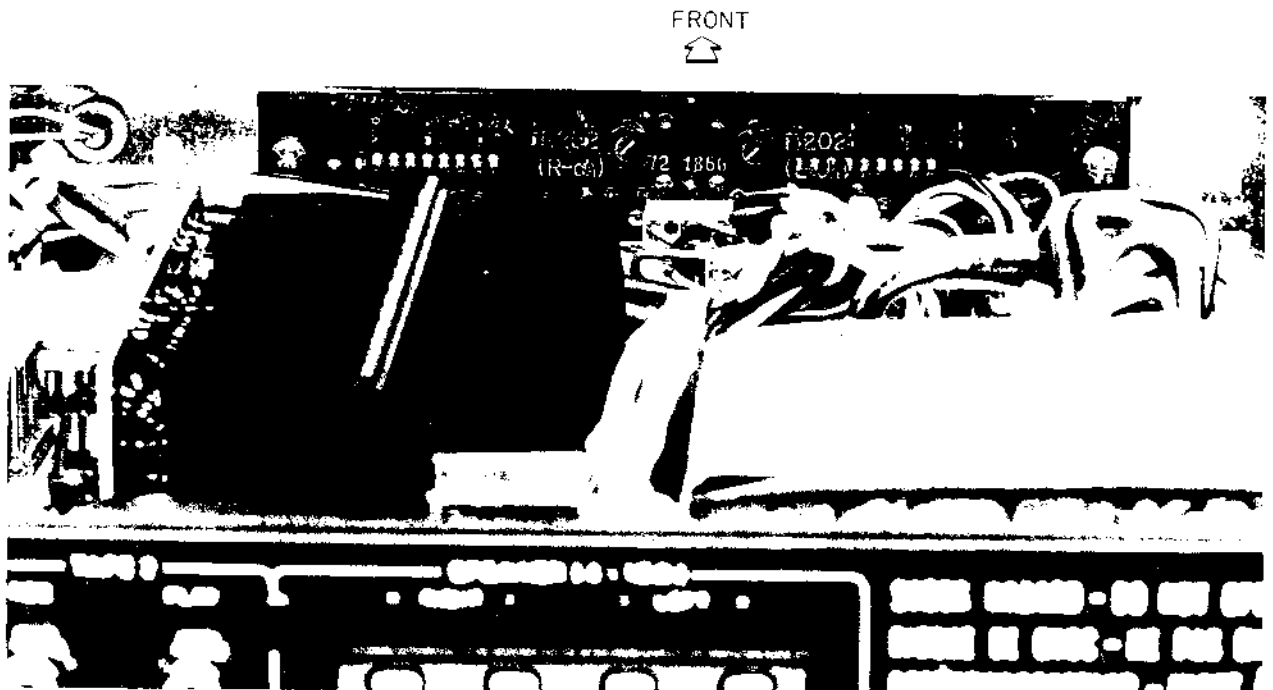

Fig. 7 Level Meter Adjustment

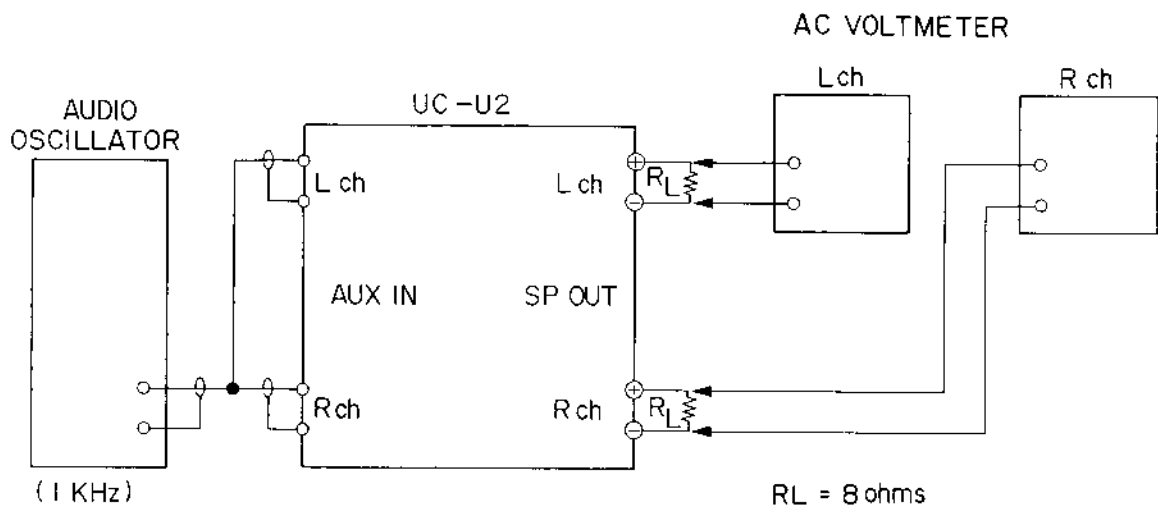

Fig. 8 Instrument Connections

Feeding in 1 kHz from audio oscillator, adjust the VOLUME Knob until the voltage at both ends of R_L (8 ohms) is 630 mV.
Also, adjust R202 (1 k Ω , L-ch) and R252 (1 k Ω , R-ch) to the point where the 0.05 watts indicator will start lighting up.

VIII. CLASSIFICATION OF VARIOUS P.C BOARDS

1. P.C BOARD TITLES AND IDENTIFICATION NUMBERS

P.C Board Title	P.C Board Number
LED Driver, Display P.C Board	72-1866
Power Supply, Protector P.C Board	72-1867
Selector Switch P.C Board	72-1868
Control, Selector Switch P.C Board	72-1869
Main Amp P.C Board (L-ch)	72-1870
Main Amp P.C Board (R-ch)	72-1870
Pre Amp Power Supply P.C Board	72-1871
EQ Amp P.C Board	72-1872
Power Switch P.C Board	72-1873

Chart-2

2) EQ AMP P.C BOARD 72-1872

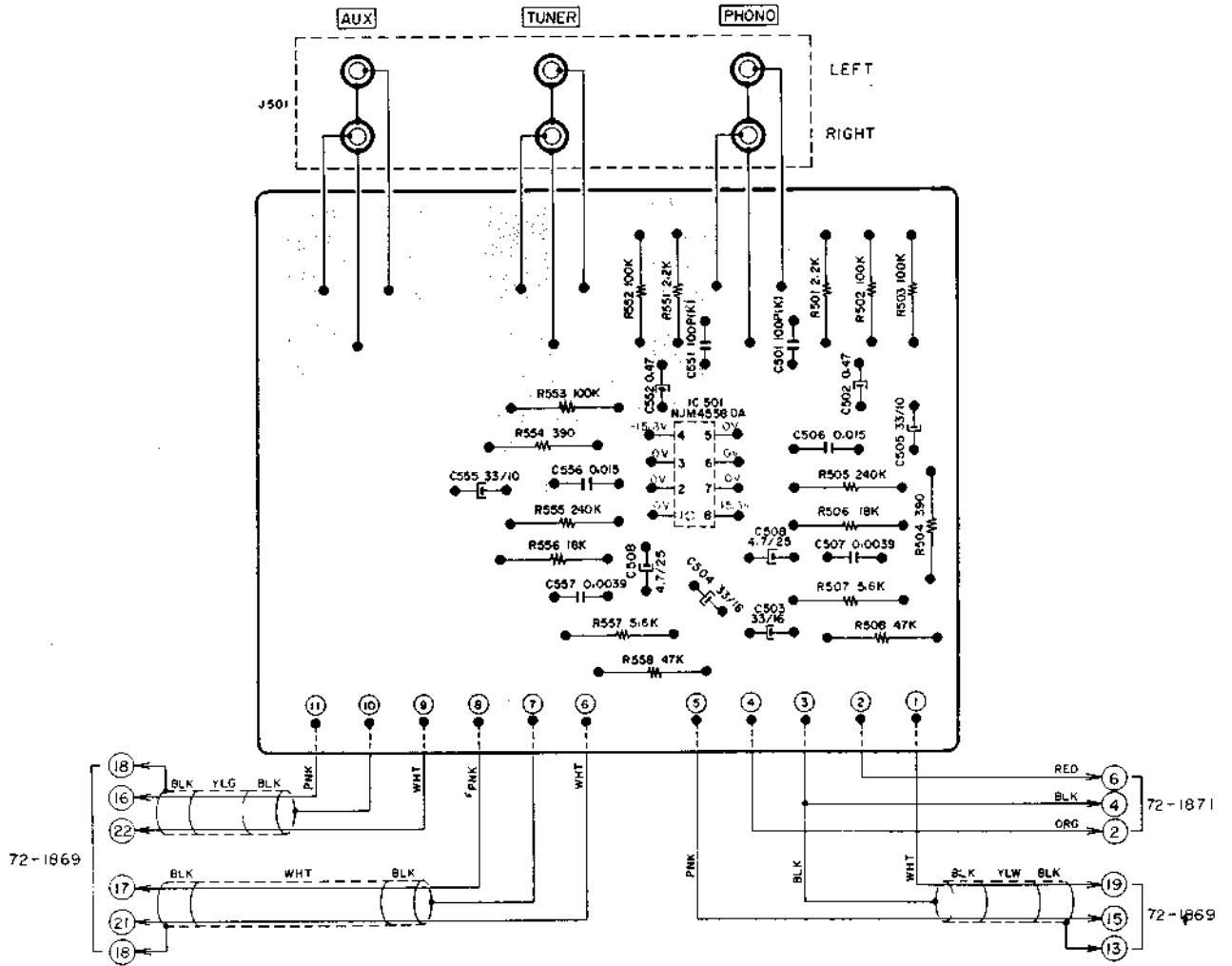

3) MAIN AMP P.C BOARD 72-1870 (L-ch, R-ch)

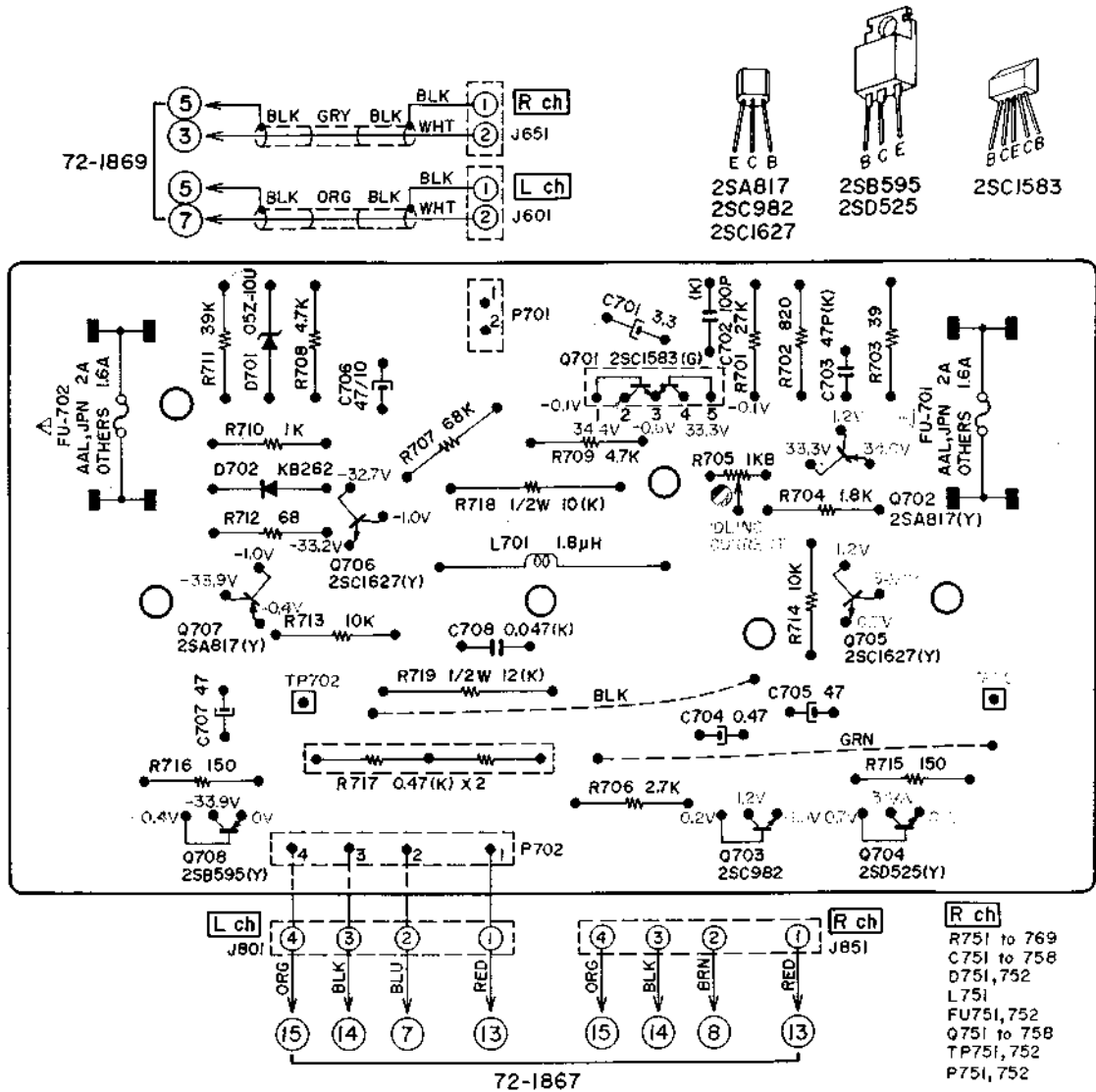

4) LED DRIVER, DISPLAY P.C BOARD 72-1866

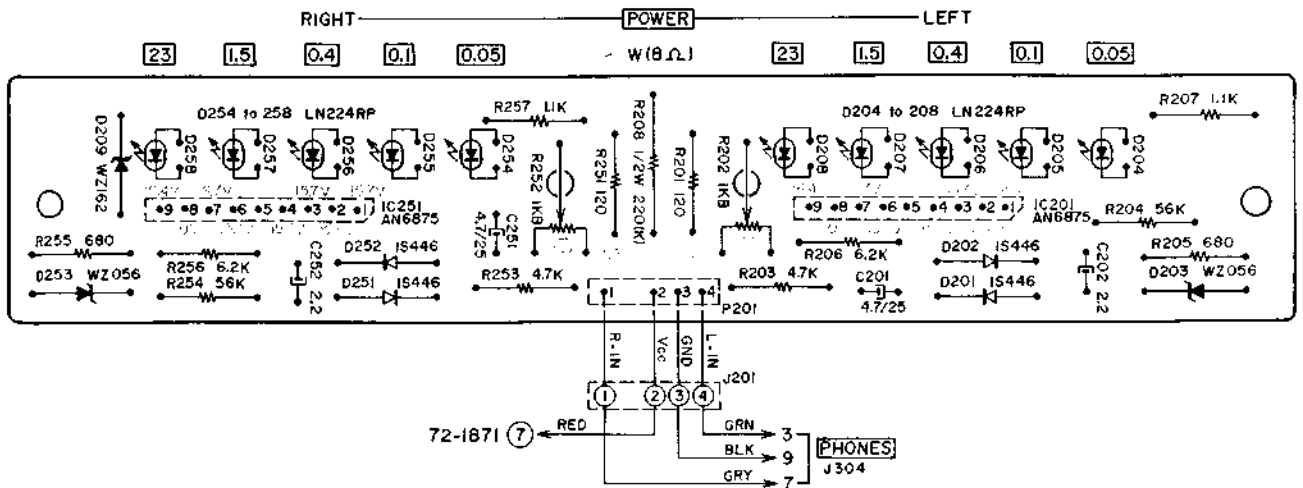

5) POWER SUPPLY, PROTECTOR P.C BOARD 72-1867

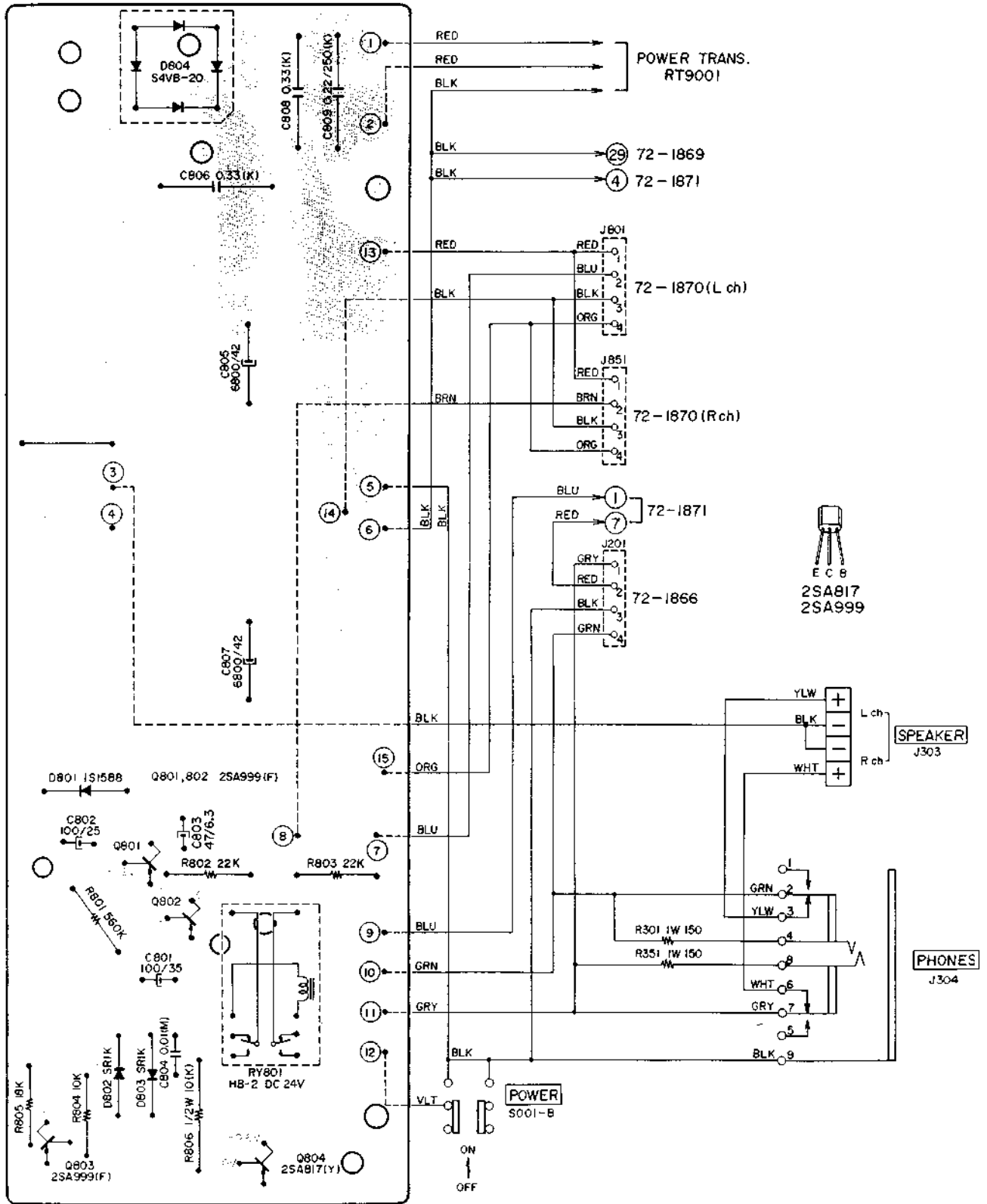

6) PRE AMP POWER SUPPLY P.C BOARD 72-1871 and POWER SWITCH P.C BOARD 72-1873

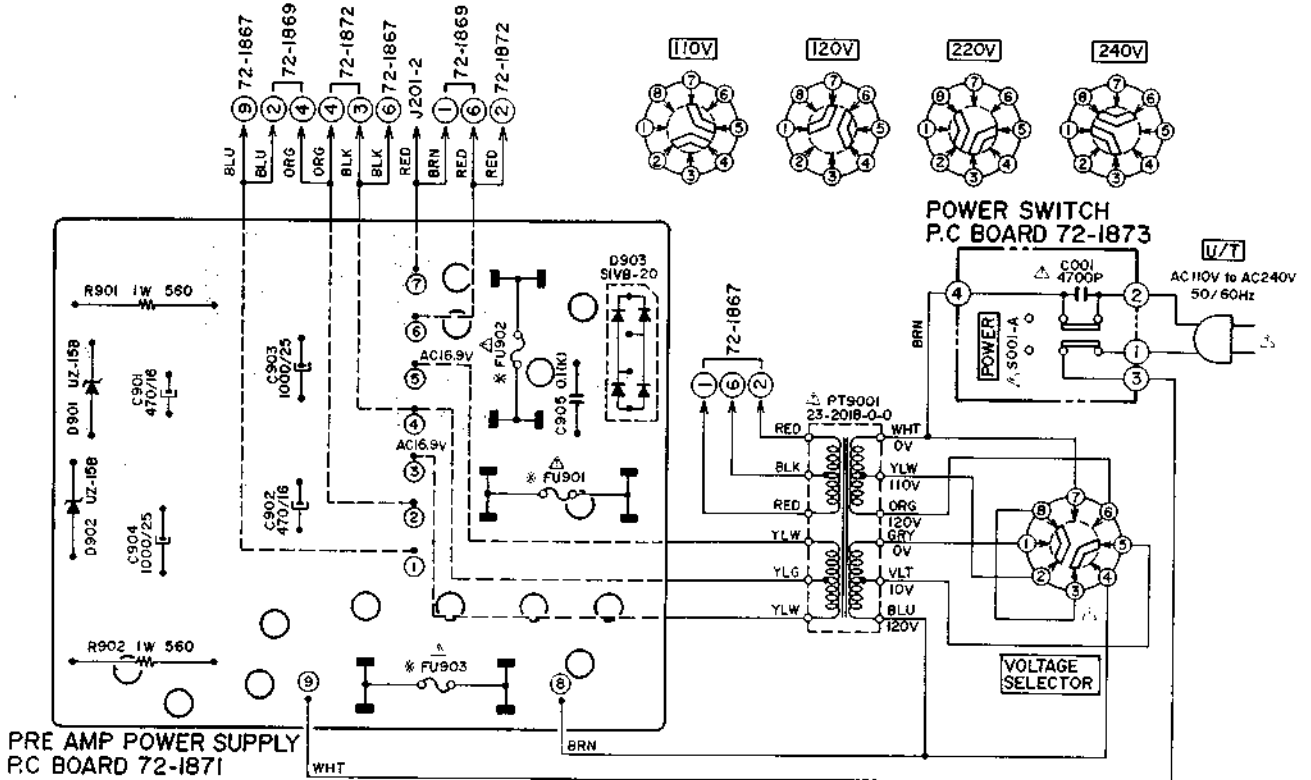

PRE AMP POWER SUPPLY P.C BOARD 72-1871

POWER SWITCH P.C BOARD 72-1873

*	U/T (110/120V) CSA	U/T (220/240V) CEE, UK, SAA	JPN, AAL
FU901, 902	T200mA	T200mA	0.63A
FU903	T1.6A	T630mA	2A

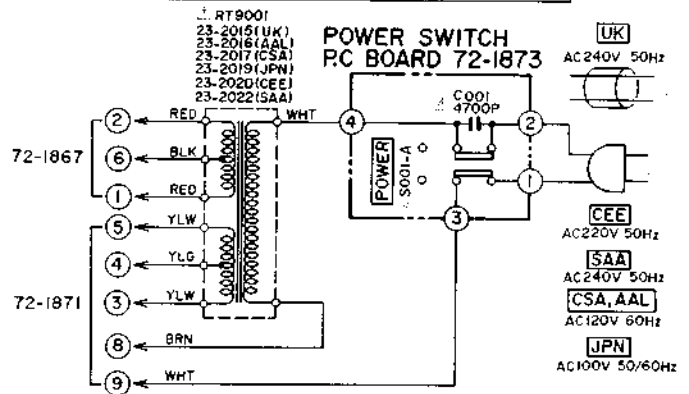

POWER SWITCH P.C BOARD 72-1873

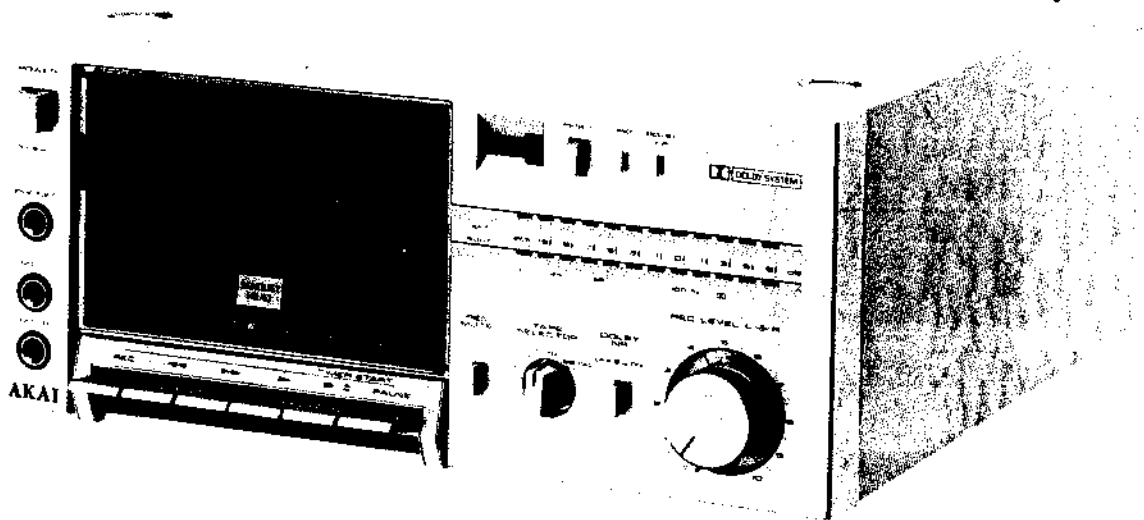

SECTION 3

STEREO CASSETTE DECK

MODEL UC-M2

ALSO APPLICABLE TO BLACK PANEL MODEL

TABLE OF CONTENTS

I. TECHNICAL DATA	30
II. DISMANTLING OF UNIT	31
III. CONTROLS	32
IV. PRINCIPAL PARTS LOCATION	33
V. VOLTAGE CONVERSION	34
VI. MECHANISM ADJUSTMENT	35
1. FLYWHEEL LOOSE PLAY ADJUSTMENT	35
2. WINDING TORQUE MEASUREMENT IN EACH MODE	35
3. PINCH ROLLER PRESSURE MEASUREMENT	35
4. TAPE SPEED ADJUSTMENT	35
VII. HEAD ADJUSTMENT	36
VIII. AMPLIFIER ADJUSTMENT	37
IX. CLASSIFICATION OF VARIOUS P.C BOARDS	40
1. P.C BOARD TITLES AND IDENTIFICATION NUMBERS	40
2. COMPOSITION OF VARIOUS P.C BOARDS	41

For basic adjustments, measuring methods, and operating principles, refer to GENERAL TECHNICAL MANUAL.

I. TECHNICAL DATA

TRACK SYSTEM	4 Track 2 Channel Stereo System
TAPE	Philips Type Cassette
TAPE SPEED	4.76 cm/s \pm 2% (1-7/8 ips. \pm 2%)
HEADS	(2): Erase head \times 1 Rec/PB sendust head \times 1
MOTOR	(1): Electronically controlled DC motor
WOW & FLUTTER	Less than 0.06% WRMS, 0.19% (DIN 45500)
TAPE WINDING TIME	100 sec. using a C-60 cassette tape
FREQUENCY RESPONSE	LN: 30 to 15,000 Hz \pm 3 dB (-20 VU) LH: 30 to 15,000 Hz \pm 3 dB (-20 VU) CrO ₂ : 30 to 16,000 Hz \pm 3 dB (-20 VU) Metal: 30 to 18,000 Hz \pm 3 dB (-20 VU)
SIGNAL TO NOISE RATIO	LN: Better than 54 dB LH: Better than 54 dB CrO ₂ : Better than 56 dB Metal: Better than 56 dB (Measured via tape with peak recording level) Dolby NR switch ON: Improves up to 10 dB above 5 kHz
HARMONIC DISTORTION	LN: Less than 1.2% LH: Less than 1.2% CrO ₂ : Less than 1.5% Metal: Less than 1.5%
CHANNEL SEPARATION	30 dB at 1,000 Hz
CROSS TALK	55 dB at 1,000 Hz
INPUT	MIC: 0.25 mV (input impedance 10 kohms) Required microphone impedance: 600 ohms Line: 70 mV (input impedance 50 kohms)
OUTPUT	Line: 410 mV at 0 VU Required load impedance: more than 2 kohms Phone: 200 mV/8 ohms at 0 VU
DIMENSIONS	280(W) \times 122(H) \times 282(D) mm (11.0 \times 4.8 \times 11.1")
WEIGHT	5.5 kg (12.1 lbs)
POWER REQUIREMENTS	100V, 50/60 Hz for Japan 120V, 60 Hz for USA and Canada 220V, 50 Hz for Europe except UK 240V, 50 Hz for UK and Australia 110/120/220/240V, 50/60 Hz internally switchable for other countries
POWER CONSUMPTION	15W for JPN Model 20W for U/T, CSA, AAL Models

* For improvement purposes, specifications and design are subject to change without notice.

* "Dolby" and the Double D symbol are trademarks of Dolby Laboratories.

(Manufactured under license from Dolby Laboratories).

II. DISMANTLING OF UNIT

In case of trouble, etc. necessitating dismantling, please dismantle in the order shown in the photographs. Reassemble in reverse order.

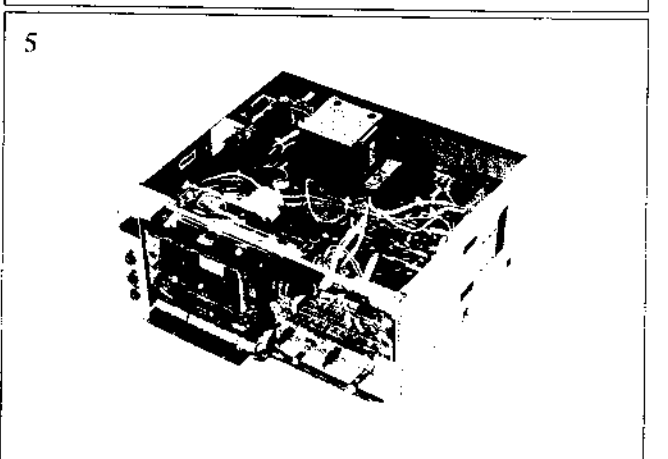
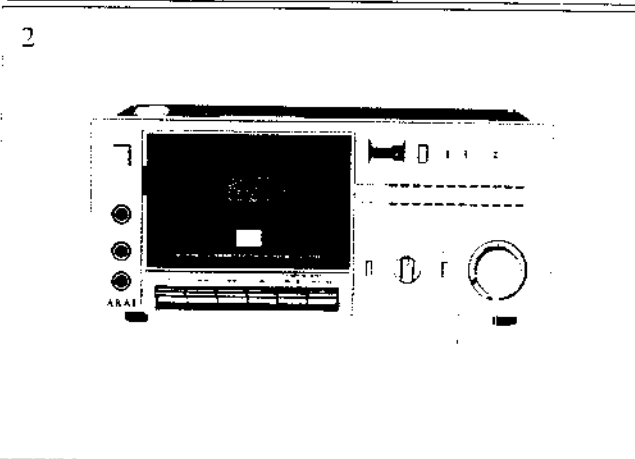
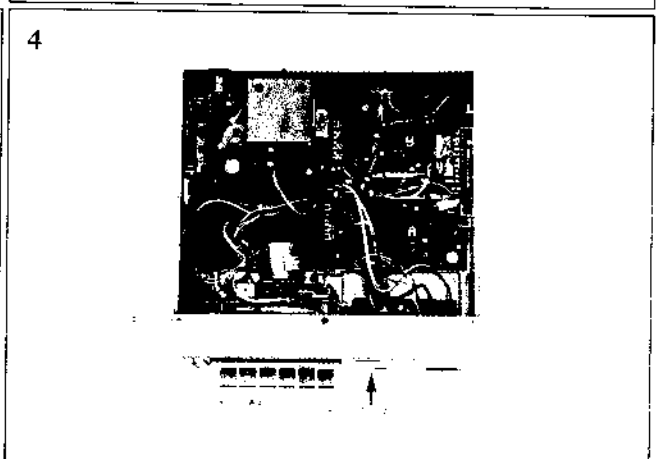
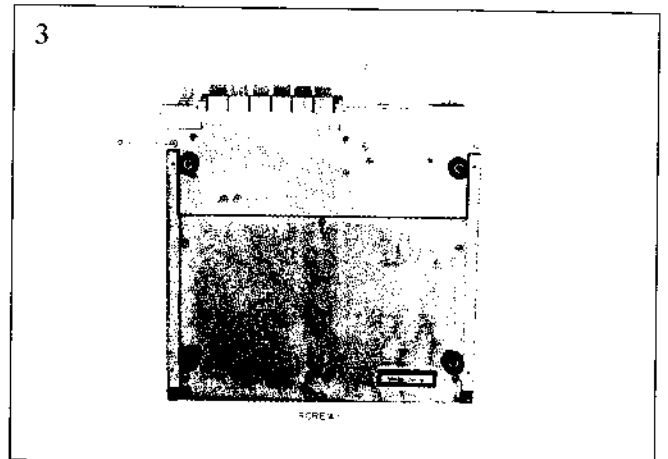
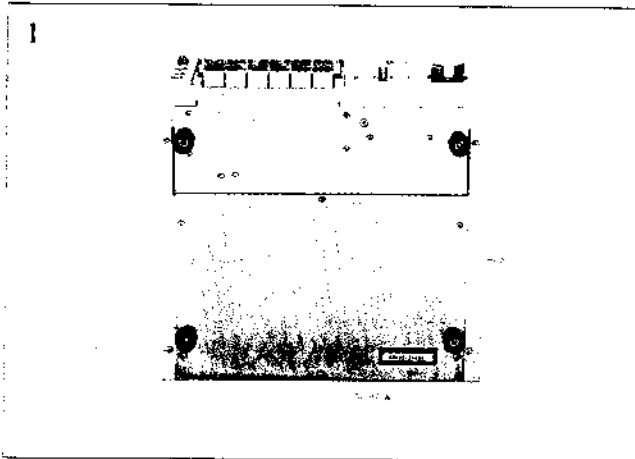

III. CONTROLS

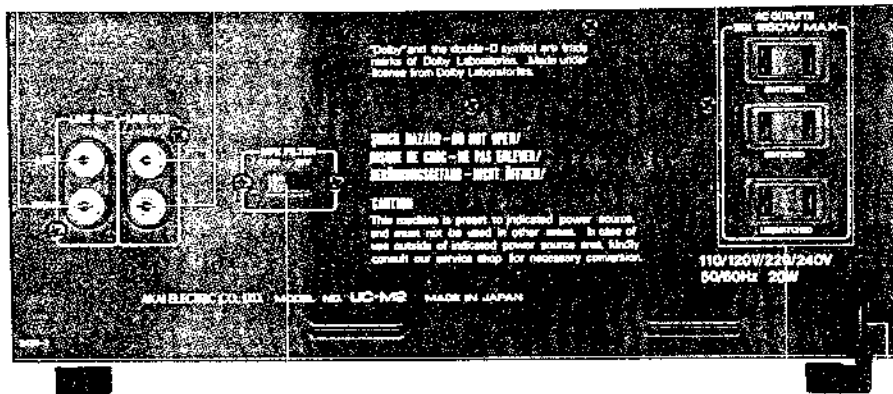
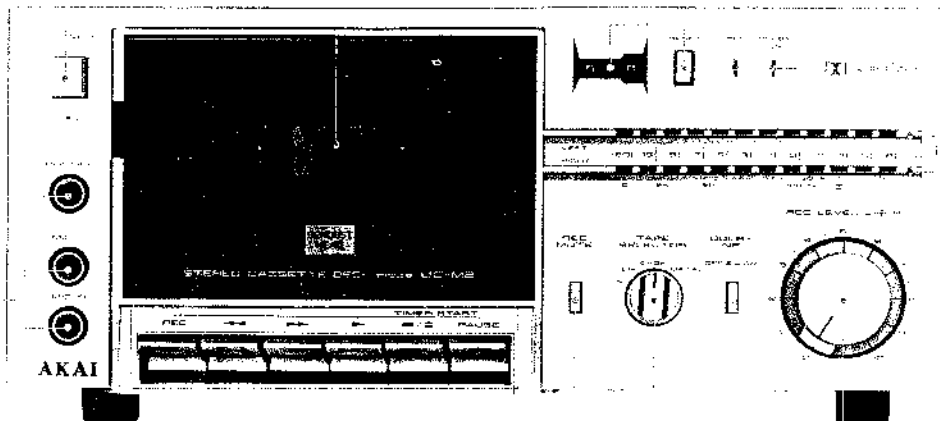

Fig. 3-1-1 (cont.)

- | | |
|------------------------------------|--|
| 1. MICROPHONE JACKS | 12. REC MUTE |
| 2. HEADPHONE JACK | 13. MODE KEYS |
| 3. POWER SWITCH | REC recording |
| 4. CASSETTE RECEPTACLE | ◀◀ rewind |
| 5. INDEX COUNTER AND RESET CONTROL | ▶▶ fast forward |
| 6. REC. INDICATOR LAMP | ▶▶▶ play |
| 7. DOLBY NR. INDICATOR LAMP | ■ ▲ stop (in the play 2nd dot at 2nd dot, 3rd dot, 4th dot, 5th dot) |
| 8. LED BAR METERS | POUSE pause |
| 9. LEFT • RIGHT REC LEVEL CONTROLS | 14. LINE IN |
| 10. DOLBY NR. SWITCH | 15. LINE OUT |
| 11. TAPE SELECTOR | 16. MPX FILTER |
| L: Hi-fi noise | 17. AC OUTLETS (110V/220V Model) |
| C: Hi-fi noise (auto muting) | 18. POWER CORD |
| C: Hi-fi muting | |
| M: Hi-fi muting | |

V. VOLTAGE CONVERSION

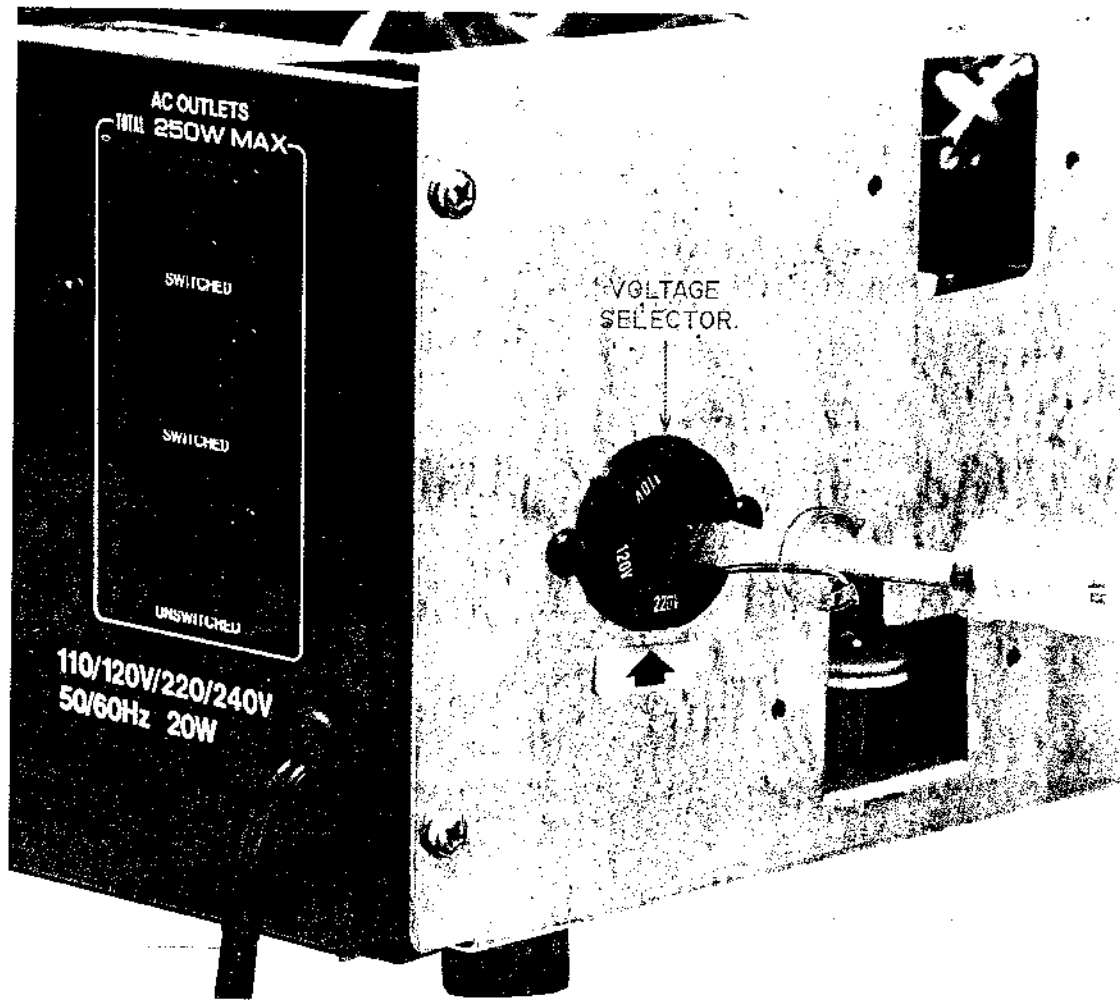

Fig. 5 Voltage Conversion

Models for Canada, USA, Australia, Japan and Europe are not equipped with this facility.

This machine can be set to 110V, 120V, 220V or 240V as required. Each machine is preset at the factory according to destination. However, if voltage change is necessary, this can be accomplished by a qualified service personnel as follows:

1. Disconnect power cord.
2. Loosen holding screws and remove upper cover.
3. With a flat bladed screwdriver rotate the selector, located on the left hand side (Power Switch side), until the arrow points to the desired voltage.

VI. MECHANISM ADJUSTMENT

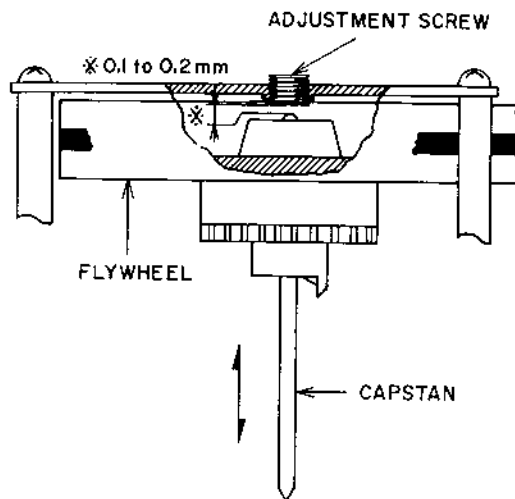

Fig. 5 Flywheel Loose Adjustment

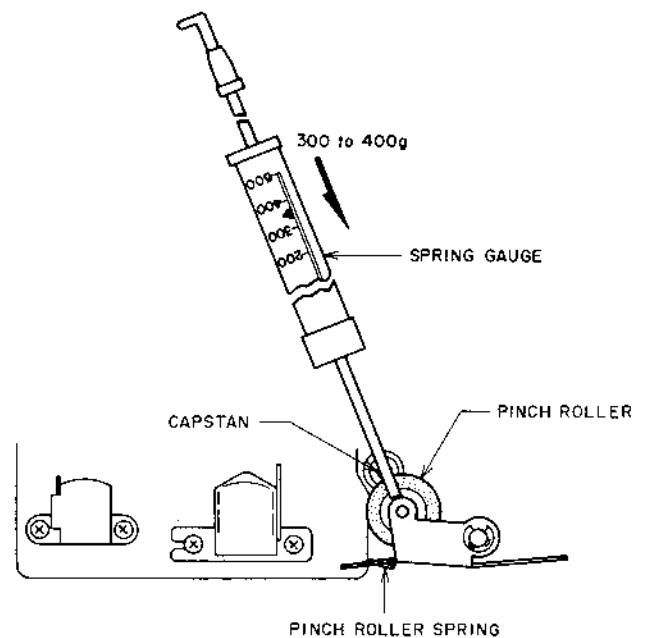

Fig. 6 Pinch Roller Pressure Measurement

1. FLYWHEEL LOOSE PLAY

ADJUSTMENT (Refer to Fig. 5)

Adjust by turning flywheel loose play adjustment screw to obtain a 0.1 to 0.2 mm of loose play when the flywheel is moved as indicated by the arrow mark. Paint lock the adjustment screw after adjustment.

2. WINDING TORQUE MEASUREMENT IN EACH MODE

Insert cassette torque meter and measure in each mode.

For fast forward and rewind measure at the end of the tape when the tape has stopped running. The specified torque is:

Playback : 35 to 70 g-cm
Fast Forward, Rewind : 70 to 150 g-cm

3. PINCH ROLLER PRESSURE

MEASUREMENT (Refer to Fig. 6)

At Playback mode, push the pinch roller with a spring gauge until the pinch roller separates from the capstan by about 1 mm to 2 mm and then gently return. Take a reading of the spring gauge indication at the moment the pinch roller touches the capstan and begins to rotate.

Specified Pinch Roller Pressure : 300 to 400 grams
In case specified pressure cannot be attained, replace the pinch roller spring.

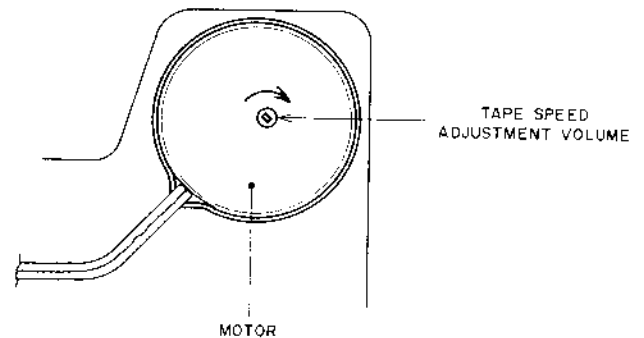

Fig. 7 Tape Speed Adjustment

4. TAPE SPEED ADJUSTMENT

(Refer to Fig. 7)

Connect the frequency counter to the line output terminals. Playback a 1,000 Hz pre-recorded test tape and adjust tape speed adjustment volume to obtain a tape speed of 1,000 Hz \pm 1%.

VII. HEAD ADJUSTMENT

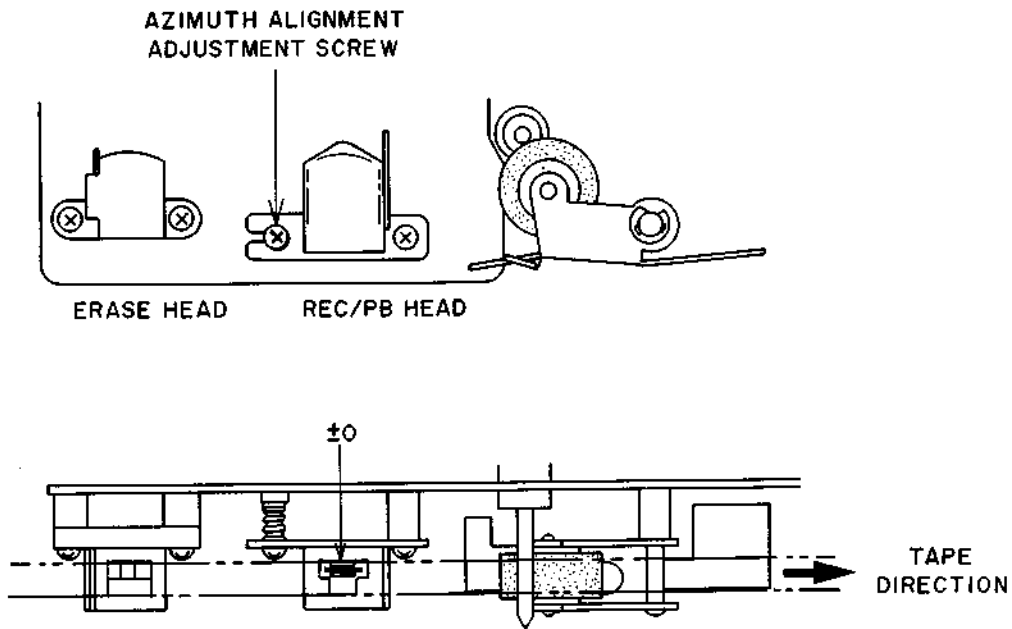

Fig. 8 Head Adjustment

- a) Playback a 10 kHz pre-recorded cassette azimuth alignment test tape and adjust screw shown in Fig. 8 to obtain maximum output on both channels.
- b) Invert cassette and confirm that the output level does not change from that obtained in Item a) above. If the output level differs, adjust in the same way as in Item a) above until both sides of the test tape display equal output.

NOTES:

1. Be sure to clean the heads prior to head adjustment.
2. Be careful not to use a magnetized driver or other magnetized tools in the vicinity of the heads.
3. Be sure to demagnetize the heads with a Head Demagnetizer before and after head adjustment.

VIII. AMPLIFIER ADJUSTMENT

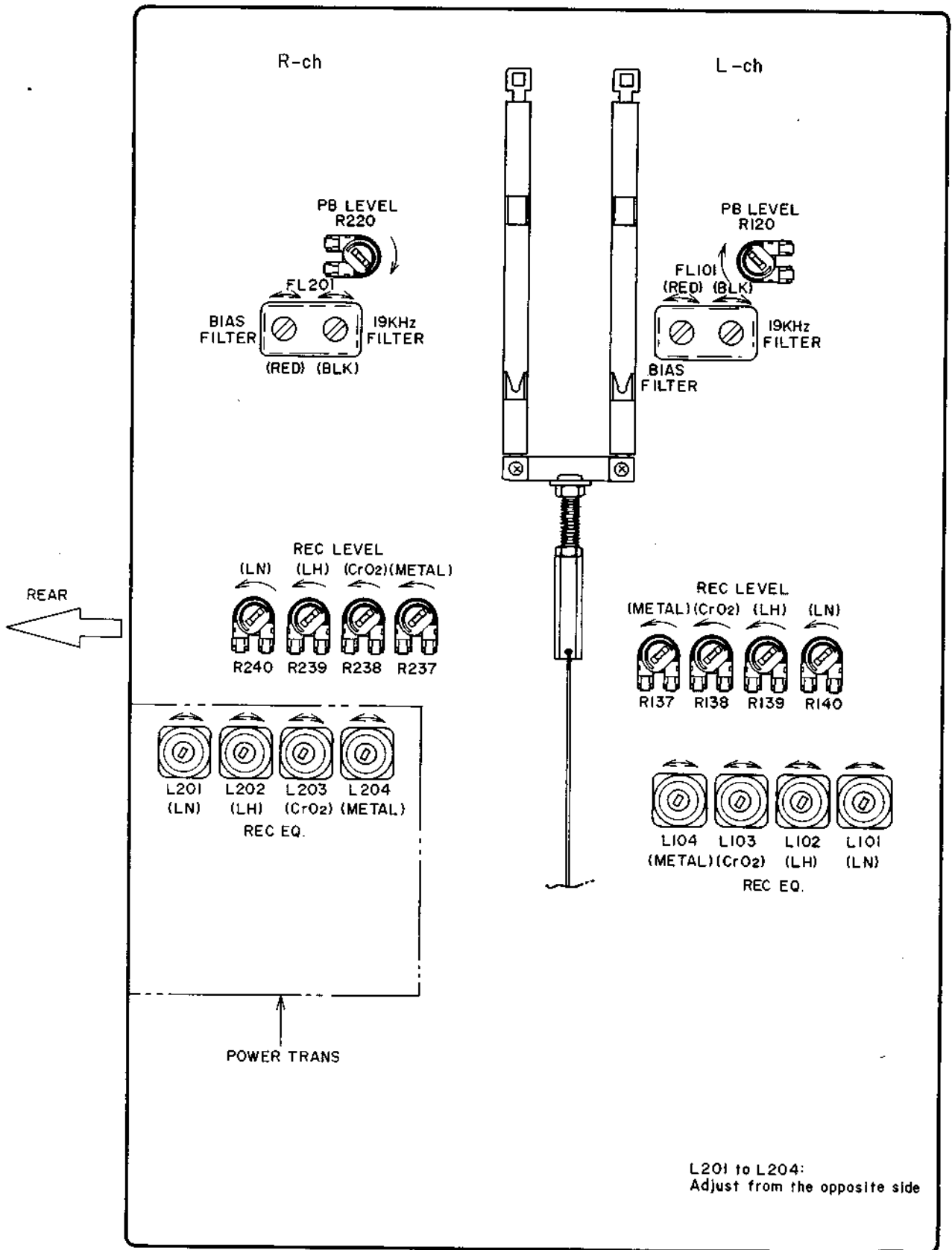

Fig. 9 REC/PB P.C. Board 72-1864

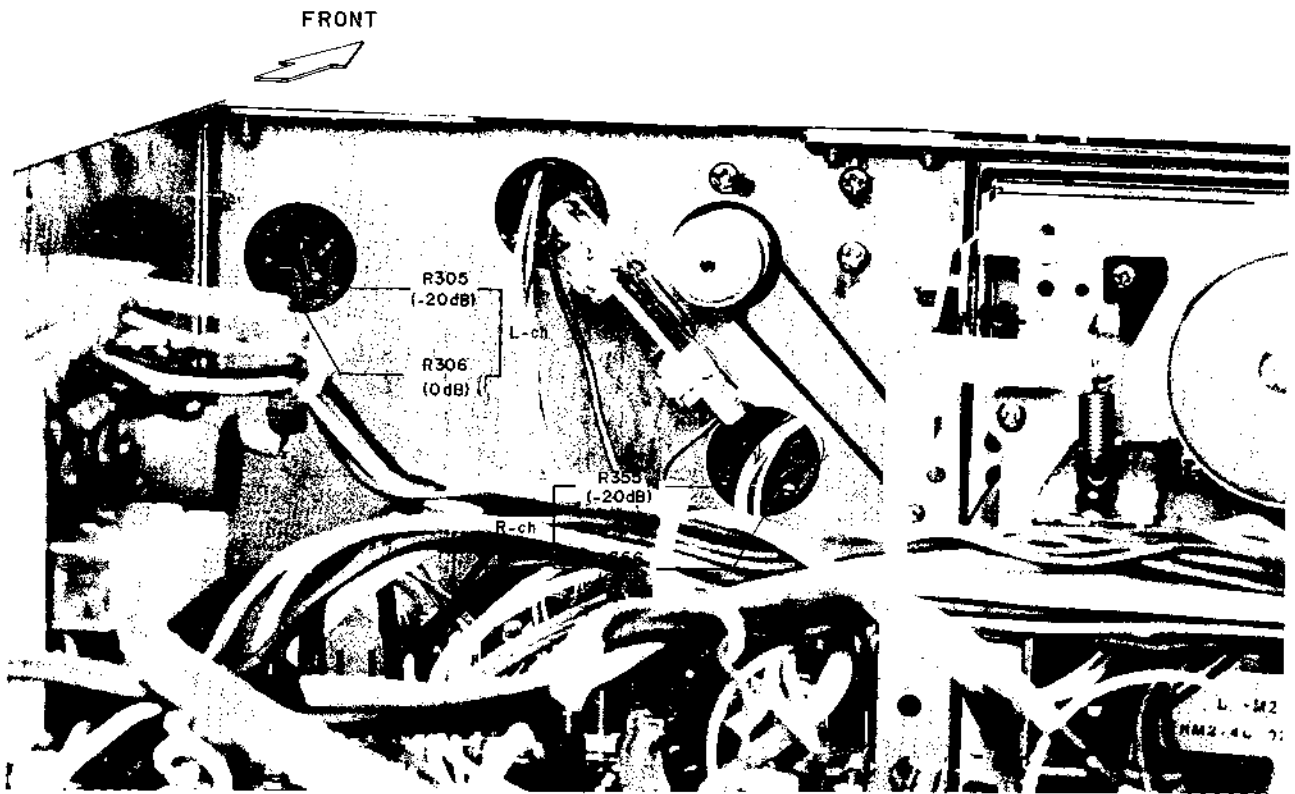

Fig. 10 Bar Meter Sensitivity Adjustment

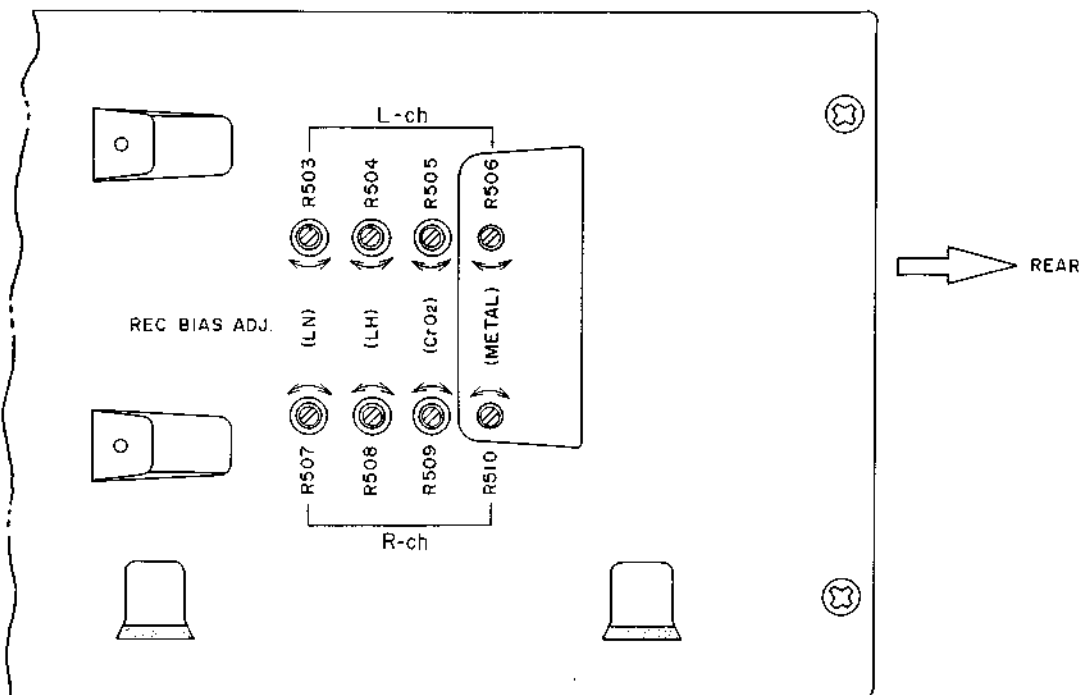

Fig. 11 Recording Bias Adjustment

Step	Adjustment Item	Test Tape Supply Signal	Mode	Adjustment Point	Result	Remarks
1	Playback Level	333 Hz, 0 VU Test Tape	PB	R120 (L) R220 (R)	-5.5 ± 0.5 dBm (410 mV)	Tape selector to LN.
2	Bar Meter Sensitivity (0 dB)	1,000 Hz -5.5 dBm from oscillator	REC	R306 (L) R356 (R)	0 dB indication	
3	Bar Meter Sensitivity (-20 dB)	1,000 Hz -25.5 dBm from oscillator	REC	R305 (L) R355 (R)	-20 dB indication	
4	Confirmation of Steps 2 and 3.					
5	METAL Position recording Bias	METAL Blank Tape 1,000 Hz, 10,000 Hz -25.5 dBm recording	REC/PB	R506 (L) R510 (R)	1,000 Hz to 10,000 Hz flat	Tape selector to METAL.
6	CrO ₂ Position recording	CrO ₂ Blank Tape 1,000 Hz, 10,000 Hz -25.5 dBm recording	REC/PB	R505 (L) R509 (R)	1,000 Hz to 10,000 Hz flat	Tape selector to CrO ₂
7	LH Position recording Bias	LH Blank Tape 1,000 Hz, 10,000 Hz -25.5 dBm recording	REC/PB	R504 (L) R508 (R)	1,000 Hz to 10,000 Hz flat	Tape selector to LH
8	LN Position recording Bias	LN Blank Tape 1,000 Hz, 10,000 Hz -25.5 dBm recording	REC/PB	R503 (L) R507 (R)	1,000 Hz to 10,000 Hz flat	Tape selector to LN
9	Confirmation of Frequency Response	-25.5 dBm recording	REC/PB	LN, LH: 30 to 15,000 Hz ± 3 dB CrO ₂ : 30 to 16,000 Hz ± 3 dB METAL: 30 to 18,000 Hz ± 3 dB		Refer to NOTE 5.
10	METAL Position recording Level	1,000 Hz -5.5 dBm recording	REC/PB	R137 (L) R237 (R)	-5.5 ± 0.5 dBm (410 mV)	Tape selector to Metal
11	CrO ₂ Position recording Level	1,000 Hz -5.5 dBm recording	REC/PB	R138 (L) R238 (R)	-5.5 ± 0.5 dBm (410 mV)	Tape selector to CrO ₂ .
12	LH Position recording Level	1,000 Hz -5.5 dBm recording	REC/PB	R139 (L) R239 (R)	-5.5 ± 0.5 dBm (410 mV)	Tape selector to LH.
13	LN Position recording Level	1,000 Hz -5.5 dBm recording	REC/PB	R140 (L) R240 (R)	-5.5 ± 0.5 dBm (410 mV)	Tape selector to LN.
14	Confirmation of Distortion Factor	1,000 Hz -5.5 dBm recording	REC/PB	LN < 1.2% LH < 1.2% CrO ₂ < 1.5% METAL < 1.5%		Refer to NOTE 5.

Step	Adjustment Item	Test Tape Supply Signal	Mode	Adjustment Point	Result	Remarks
15	Bias Filter adjustment	84 kHz from an oscillator	REC	FL101 (RED) FL201 (RED)	Minimum AC Voltmeter indication	Refer to NOTE 7.
16	19 kHz Filter adjustment	19 kHz from an oscillator	REC	FL101 (BLK) FL201 (BLK)	Minimum AC Voltmeter indication	MPX Filter Switch to ON (REAR Panel) Refer to NOTES 6, 7.

Chart-1

- NOTES:**
1. Dolby NR Switch to OFF Position.
 2. Except for Step 16, set MPX Filter Switch to OFF Position.
 3. Because each of these adjustments is vital to perfect Dolby NR circuit operation, ensure that they are carried out with as few errors as possible.
 4. Use the following cassette measuring tapes:
 - LN Tape : TDK D C-60
 - LH Tape : Maxell UD C-60
 - CrO₂ Tape : TDK SA C-60
 - Metal Tape : TDK MA-C C-60
 5. If either the distortion factor or the high range frequency characteristics do or not satisfy the specifications, carry out adjustment items 5 to 14 while changing the amount of high range compensation with the REC EQ coil (L101 to 104, L201 to 204).
 6. Adjust the oscillator's frequency to give a frequency counter reading of 19.00 kHz.
 7. Unless the core is moved unintentionally this adjustment is not necessary.

IX. CLASSIFICATION OF VARIOUS P.C BOARDS

1. P.C BOARD TITLES AND IDENTIFICATION NUMBERS

P.C Board Title	P.C Board Number
Selector P.C Board	72-1851
LED P.C Board	72-1852
LED Ind. P.C Board	72-1853
REC/PB P.C Board	72-1864
OSC P.C Board	72-1865
Power Switch P.C Board	72-1873
Reed Switch P.C Board	72-1639

Chart-2

2) LED IND. P.C BOARD 72-1853

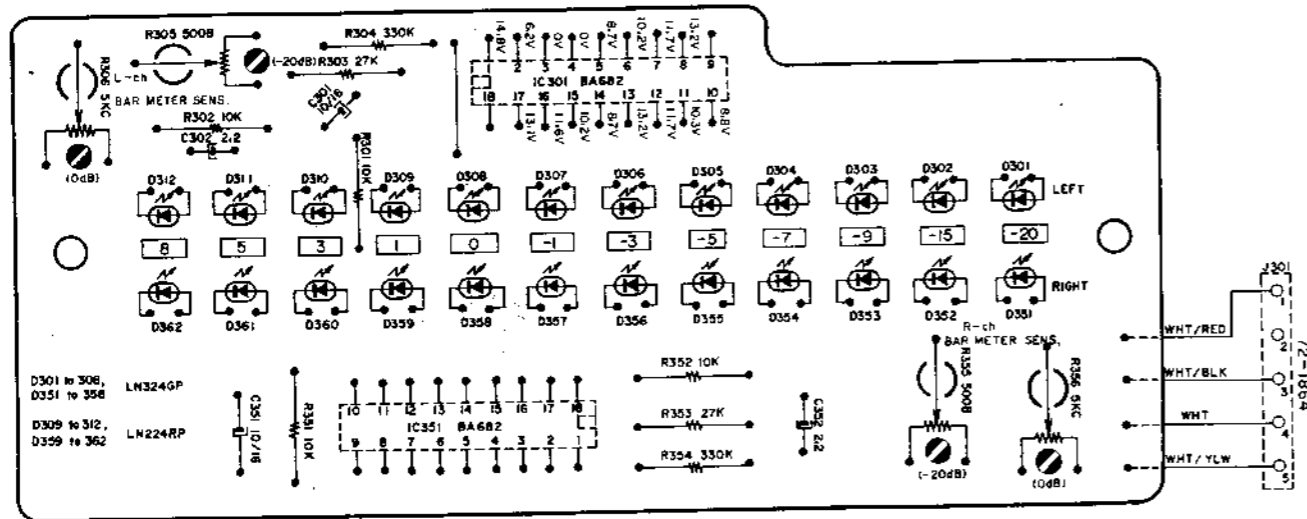

3) OSC P.C BOARD 72-1865

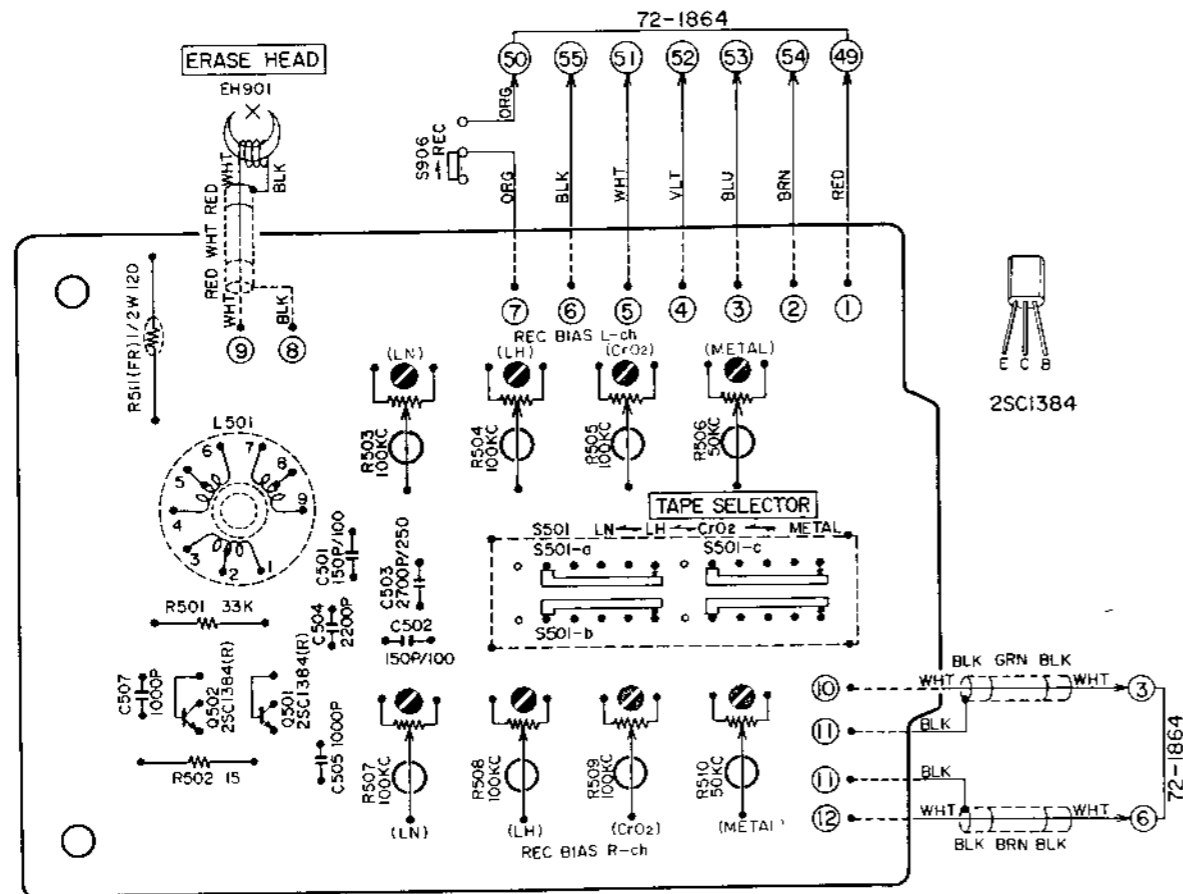

	Q501			Q502			L501							
	E	C	B	E	C	B	1	2	3	5	7	8		
LN	0.6V	10.3V	0V	0.6V	10.3V	0V	0V	0V	0V	10.2V	4.0VAC	34.2VAC		
LH	0.6V	10.0V	0V	0.6V	10.0V	0V	0.1V	0.1V	0V	9.7V	4.5VAC	39.2VAC		
CrO2	0.9V	20.4V	-0.8V	0.9V	20.4V	-0.8V	-0.8V	-0.8V	0.8V	20.2V	8.8VAC	70.0VAC		
METAL	1.1V	18.8V	-0.3V	1.1V	18.7V	-0.3V	-0.3V	-0.3V	-0.3V	1.5V	7.5VAC	62.3VAC		

4) SELECTOR P.C BOARD 72-1851 and LED P.C BOARD 72-1852

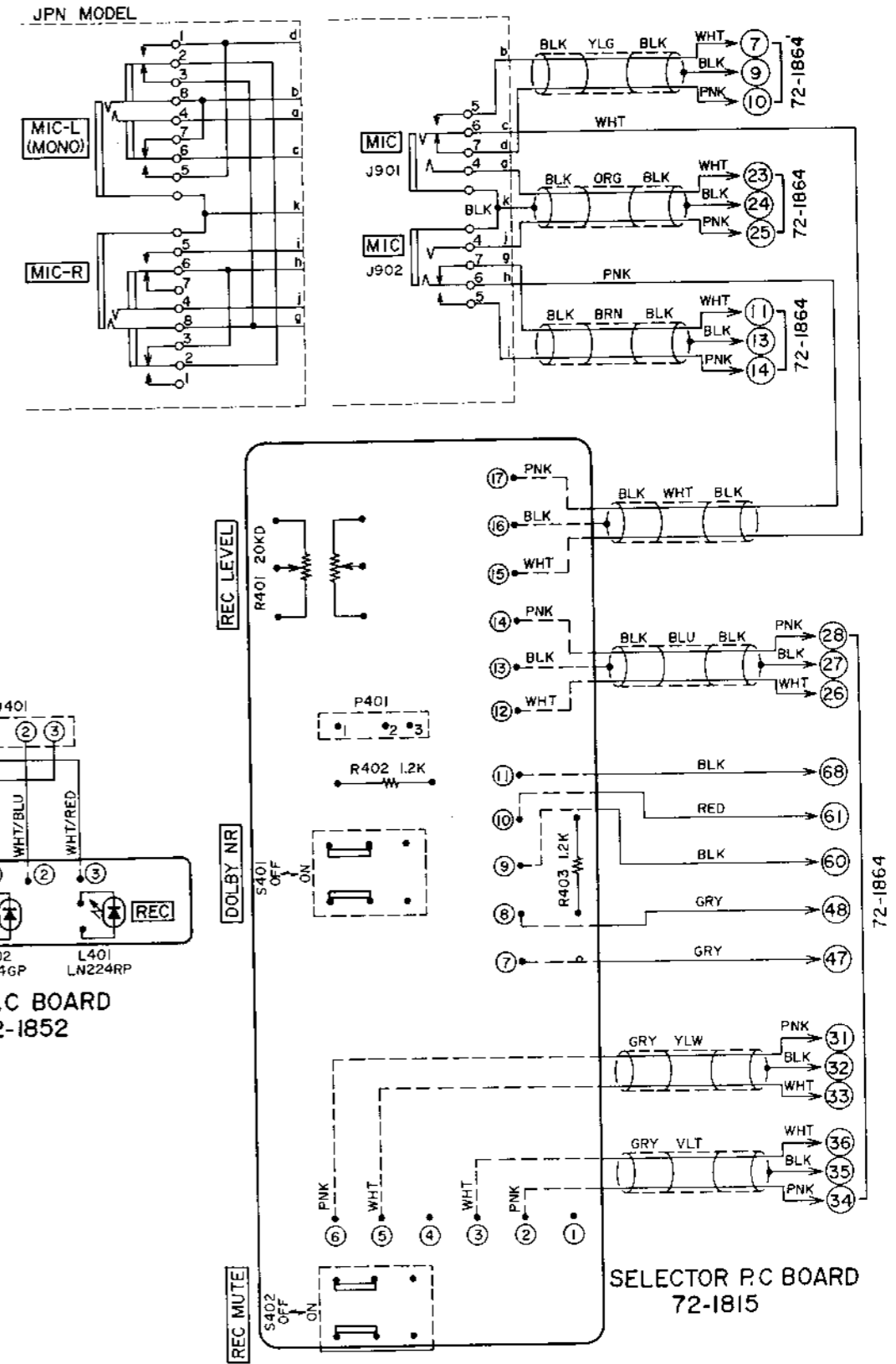

MEMO

MEMO

MEMO

MEMO

MEMO

SECTION 4

PARTS LIST

TABLE OF CONTENTS

I. MODEL UC-K2

- 1. RECOMMENDED SPARE PARTS LIST 50
- 2. TUNER P.C BOARD (72-1859) BLOCK 52
- 3. LED IND P.C BOARD (72-1860) BLOCK 52
- 4. ASSEMBLY BLOCK 53
- 5. FINAL ASSEMBLY BLOCK 54

II. MODEL UC-U2

- 1. RECOMMENDED SPARE PARTS LIST 56
- 2. MAIN AMP P.C BOARD (72-1870) BLOCK 58
- 3. CONTROL, SELECTOR SW. P.C BOARD
(72-1869) BLOCK 58
- 4. POWER SUPPLY, PROTECTOR P.C BOARD
(72-1867) BLOCK 58
- 5. EQ AMP P.C BOARD (72-1872) BLOCK 58
- 6. LED DRIVER, DISPLAY P.C BOARD
(72-1866) BLOCK 59
- 7. PRE AMP POWER SUPPLY P.C BOARD
(72-1871) BLOCK 59
- 8. ASSEMBLY BLOCK 60
- 9. FINAL ASSEMBLY BLOCK 62

III. MODEL UC-M2

- 1. RECOMMENDED SPARE PARTS LIST 63
- 2. REC/P.B P.C BOARD (72-1864) BLOCK 66
- 3. OSC P.C BOARD (72-1865) BLOCK 67
- 4. LED IND. P.C BOARD (72-1853) BLOCK 67
- 5. SELECTOR P.C BOARD (72-1851) BLOCK 67
- 6. LED P.C BOARD (72-1852) BLOCK 67
- 7. MECHA ASSEMBLY BLOCK (1) 68
- 8. MECHA ASSEMBLY BLOCK (2) 70
- 9. ASSEMBLY BLOCK 72
- 10. FINAL ASSEMBLY BLOCK 74

INDEX

- 1. MODEL UC-K2 75
- 2. MODEL UC-U2 76
- 3. MODEL UC-M2 77

Resistor and Capacitor which is not listed in this parts list, please refer to COMMON LIST FOR SERVICE PARTS.

HOW TO USE THIS PARTS LIST

1. This parts list is compiled by various individual blocks based on assembly process.
2. When ordering parts, please describe parts number, serial number, and model number in detail.
3. How to read List

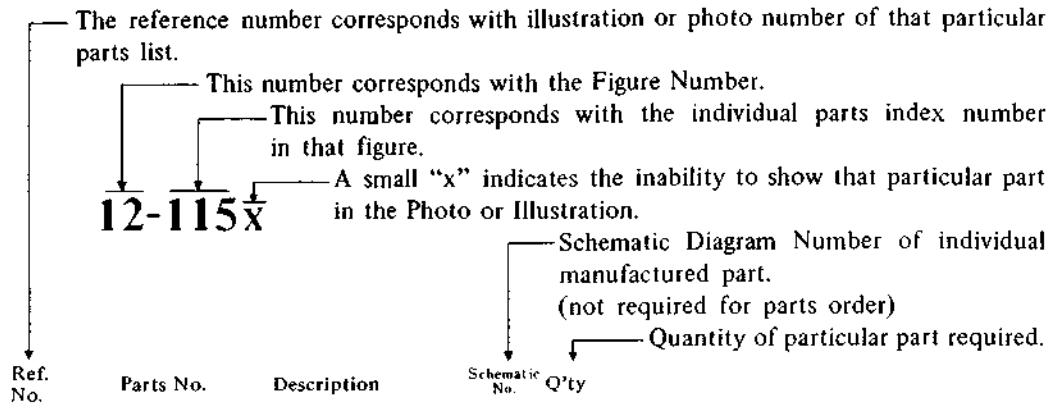



FLYWHEEL BLOCK #13				
12-115x	800425	Flywheel Block Assy. Comp.	RD-233	1
12-116	244506	Flywheel Only	RD-275	1
12-117x	244754	Felt, Flywheel	RD-236	1
12-118	251324	Main Metal Case	RD-237	1
12-119	253080	Main Metal		

4. The symbol numbers shown on the P.C. Board list can be matched with the Composite Views of Components of the Schematic Diagram or Service Manual.
5. Please utilize separate "Common List for Service Parts" for Resistor Parts orders.
6. The shape of the parts and parts name, etc. can be confirmed by comparing them with the parts shown on the Electrical Parts Table of P.C. Board.
7. Both the kind of part and installation position can be determined by the Parts Number. To determine where a parts number is listed, utilize Parts Index at end of Parts List.
It is necessary first of all to find the Parts Number. This can be accomplished by using the Reference Number listed at right of parts number in the Parts Index. (meaning of ref. no. outlined in Item 3 above).
8. Utilize separate "Price List for Parts" to determine unit price. The most simple method of finding parts Price is to utilize the reference number.

CAUTION:

1. When placing an order for parts, be sure to list the parts no., model no., and description. There are instances in which if any of this information is omitted, parts cannot be shipped or the wrong parts will be delivered.
2. Please be careful not to make a mistake in the parts no. If the parts no. is in error, a part different from the one ordered may be delivered.
3. Because parts number and parts unit supply in the Preliminary Service Manual (Basic Parts List) may be partially changed, please use this parts list for all future reference.

WARNING:  INDICATES SAFETY CRITICAL COMPONENTS. FOR CONTINUED SAFETY, REPLACE SAFETY CRITICAL COMPONENTS ONLY WITH MANUFACTURER'S RECOMMENDED PARTS.

AVERTISSEMENT:  IL INDIQU LES COMPOSANTS CRITIQUES DE SURETE. POUR MAINTENIR LE DEGRE DE SECURITE DE L'APPAREIL NE REMPLACER LES COMPOSANTS DONT LE FONCTIONNEMENT EST CRITIQUE POUR LA SECURITE QUE PAR DES PIECES RECOMMANDEES PAR LE FABRICANT.

AC INLET SYSTEM

This model is equipped with an AC INLET SYSTEM. Please refer to the AC INLET SYSTEM CHART below for the specific type. By the AC INLET SYSTEM, AC (mains) cord can be connected to and disconnected from the model because the model is provided with socket exclusively for AC (mains) cord on its main body. Please note, however, that certain models are not equipped with this system and has a built-in AC (mains) cord as before.

AC INLET SYSTEM CHART

CLASS I

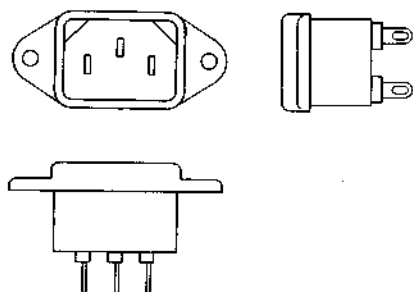

Picture 1
AC INLET
to be
installed
on machines

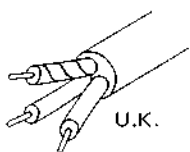
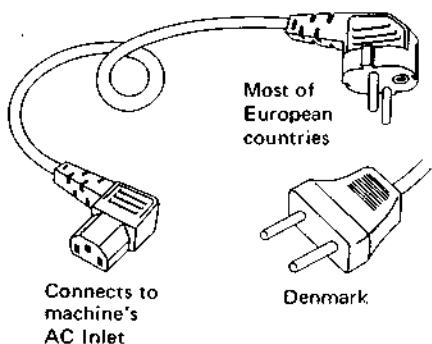

CLASS II

☐ This mark indicating double insulation will be attached to machine's rear panel

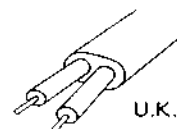
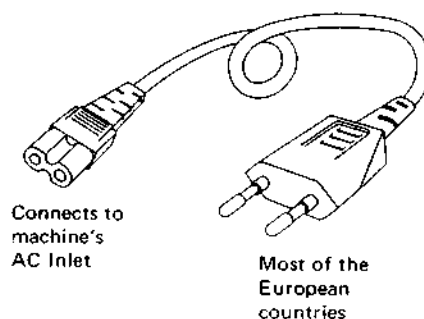
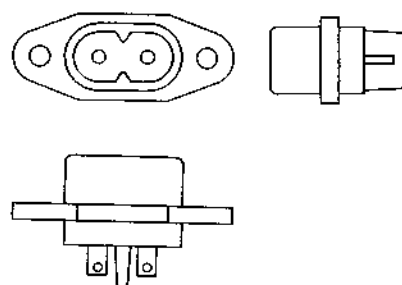

Picture 2
AC (mains)
cord

Parts List for AC (mains) Cord Set

Standard		Description	Type of AC Inlet	Parts No.
Class I	CEE	Cord Set CEE (3 cores)	3P	EW302993
	BEAB	Cord Set BEAB (3 cores)	3P	EW302994
	SAA	Cord Set SAA (3 cores)	3P	EW302996
	U/T	Cord Set U/T (3 cores)	3P	EW302646
Class II	CEE	Cord Set CEE (2 cores)	2P	EW638144
	BEAB	Cord Set BEAB (2 cores)	2P	EW302995
	SAA	Cord Set SAA (2 cores)	2P	EW302991
	U/T	Cord Set U/T (2 cores)	2P	EW302899

I. MODEL UC-K2

1. RECOMMENDED SPARE PARTS LIST

Because, if the parts listed below are on hand, almost any repair can be accomplished, we suggest that you stock these Recommended Spare Parts Items.

Parts No.	Description	Notes
BA704926	Tuner P.C Board Comp. UC-K2	Ext. CEE, JPN
BA704994	Tuner P.C Board Comp. UC-K2 (CEE)	CEE
BA704848	Tuner P.C Board Comp. UC-K2J	JPN
BT704925	△ Trans Power UC-K2 (AAL)	
BT704924	△ Trans Power UC-K2 (UK, SAA)	
BT705195	△ Trans Power UC-K2 (CSA)	
BT704923	△ Trans Power UC-K2 (CEE)	
BT704941	△ Trans Power UC-K2 (JPN)	
BT704927	△ Trans Power UC-K2 (U/T)	
BT704872	IF Trans 12HF	
EC704883	Ceramic Trimmer CVD30-41	
ED704829	D Germa 1S446	
ED704951	D LE LN224RP RED	
ED704940	D LE LN324GP GRN	
ED704866	D Silicon SR1K	
ED704827	D Silicon 1S1555	
ED323530	D Zener 05Z12 U	
ED324194	D Zener 05Z5.1 L	
EE704922	Bar ANT UC-K2	
EE704875	FM Front End UC-K2	Ext. JPN
EE704876	FM Front End UC-K2J	JPN
EF704909	△ Fuse GGS 0.5A	AAL
EF704897	△ Fuse GGS 0.8A	AAL
EF704912	△ Fuse NR 0.3A	JPN
EF704919	△ Fuse NR 0.8A	JPN
EF704907	△ Fuse 200mAT	U/T, CEE, UK, SAA, CSA
EF704895	△ Fuse 630mAT	U/T, CEE, UK, SAA, CSA
EI704835	IC AN115	
EI322248	IC LA123IN	
EI213390	IC NJM4558D	
EI704824	IC TA7060AP	
EI323247	IC TA7324P	
EI704828	IC TCA440	
EL704920	PL Tube 6.3V 130mA	
EO704881	OSC Coil 130μH	
ER704877	Ceramic Filter 468kHz	
ER704826	Filter CE CFSH-107M3S	
ER704888	Low Pass Filter FB2003	
ES704989	△ SW. Push UC-M2	CEE
ES704990	△ SW. Push UC-M2	U/T, JPN, CSA, UK, SAA

Parts No.	Description	Notes
ES704991	△ SW. Push UC-M2	AAL
ES704871	SW. Push 3-Throw UC-K2	
ES705007	△ Velt Change SW. ESE-372	U/T
ET307234	TR 2SC1815 (Y) (GR)	
ET704825	TR 2SC380TM (O)	
ET306721	TR 2SC790 (O) (Y)	
EV704884	R S-Fix H EVLS3A 3P 102	
EV704886	R S-Fix H EVLS3A 3P 103	
EV704873	R S-Fix H EVLS3A 3P 503	
EW704959	△ AC Cord UC-K2 (AAL)	ALL
EW705002	△ AC Cord UC-M2	CEE
EW705004	△ AC Cord UC-M2	UK
EW705006	△ AC Cord UC-M2	JPN
EW705098	△ AC Cord UC-M2	SAA
EW705099	△ AC Cord UC-M2	CSA
EW705100	△ AC Cord UC-M2	U/T

2. TUNER P.C BOARD (72-1859) BLOCK

Symbol No.	Parts No.	Description	Schematic No.
2-1	BA704926	Tuner P.C Board Comp. UC-K2 (Ext. CEE, JPN)	01-6047
2-2	BA704994	Tuner P.C Board Comp. UC-K2 (CEE)	01-6047C
2-3	BA704848	Tuner P.C Board Comp. UC-K2J (JPN)	01-6047J
2-4	EE704875	FM Front End UC-K2 (Ext. JPN)	01-471
2-5	EE704876	FM Front End UC-K2J (JPN)	01-472
2-IC101	EI704828	IC TCA440	TCA440
2-IC201	EI704824	IC TA7060AP	TA7060A
2-IC202	E1322248	IC LA1231N	45-8-443
2-IC301	EI704835	IC AN115	AN115
2-IC302	EI213390	IC NJM4558D	45-8-491
2-IC401	EI323247	IC TA7324P	45-8-442
2-IC501 to 503	EI213390	IC NJM4558D	45-8-491
2-Q201	ET704825	TR 2SC380TM (O)	2SC380TMO
2-Q301	ET307234	TR 2SC1815(Y)(GR)	45-1-299
2-Q401	ET307234	TR 2SC1815(Y)(GR)	45-1-299
2-Q601	ET306721	TR 2SC790(O)(Y)	45-1-304
2-D101	ED704829	D Germa 1S446	1S446
2-D201 to 203	ED704827	D Silicon 1S1555	1S1555
2-D204	ED324194	D Zener 05Z5.1 L	45-8-76
2-D205	ED704827	D Silicon 1S1555	1S1555
2-D301 to 303	ED704827	D Silicon 1S1555	1S1555
2-D401,402	ED704827	D Silicon 1S1555	1S1555
2-D403,404	ED704866	D Silicon SR1K	SR1K
2-D501,502	ED704827	D Silicon 1S1555	1S1555
2-D601	ED323530	D Zener 05Z12 U	45-8-76
2-D602 to 606	ED704866	D Silicon SR1K	SR1K
2-S101 to 103	ES704871	SW Push 3-Throw UC-K2	81-2222
2-CF201,202	ER704826	Filter CE CFSH-107M3S	19-126
2-T101	ER704877	Ceramic Filter 468kHz	13-342
2-T102	BT704887	IF Trans. 455kHz	13-326
2-T103	EO704881	OSC Coil 130μH	12-357
2-T201	BT704872	IF Trans. 12HF	13-331
2-FL301,302	ER704888	Low Pass Filter FB2003	19-117
2-R107	EV704884	R S-Fix H EVLS3A 3P 102	41-732
2-R210	EV704873	R S-Fix H EVLS3A 3P 503	41-748
2-R304	EV704886	R S-Fix H EVLS3A 3P 103	41-746
2-R317	EV704873	R S-Fix H EVLS3A 3P 503	41-748
2-R515,516	EV704873	R S-Fix H EVLS3A 3P 503	41-748
2-C101	EC704883	Ceramic Trimmer CVD30-41	36-124
2-C103	EC704883	Ceramic Trimmer CVD30-41	36-124
2-C105	EC704831	C STY V 392J 50.0DC	
2-C108	EC704830	C STY V 371J 50.0DC	
2-C122	EC244888	C TT V DTS R10K 50.0DC	24-15-8
2-C304	EC405898	C STYV 471J 50DC	24-11-3
2-C306,307	EC318378	C TT V D R22M 35.0DC	24-15-12
2-C401	EC311778	C EC V NP LM 1R0 50.0DC	24-17-33
2-C601	EC704838	C EC V 102 6.3DC	
2-FU601,602	EF704907	Δ Fuse 200mA (U/T, CEE, UK, SAA, CSA)	
2-FU601,602	EF704909	Δ Fuse GGS 0.5A (AAL)	
2-FU601,602	EF704912	Δ Fuse NR 0.3A (JPN)	
2-FU603	EF704895	Δ Fuse 630mA (U/T, CEE, UK, SAA, CSA)	
2-FU603	EF704897	Δ Fuse GGS 0.8A (AAL)	
2-FU603	EF704919	Δ Fuse NR 0.8A (JPN)	

3. LED IND P.C BOARD (72-1860) BLOCK

Symbol No.	Parts No.	Description	Schematic No.
3-D701 to 706	ED704951	D LE LN224RP RED	LN224RP
3-D801,802	ED704940	D LE LN324GP GRN	LN324GP
3-LA901 to 904	EL704920	PL Tube 6.3V 130mA	83-351-0-6

4. ASSEMBLY BLOCK

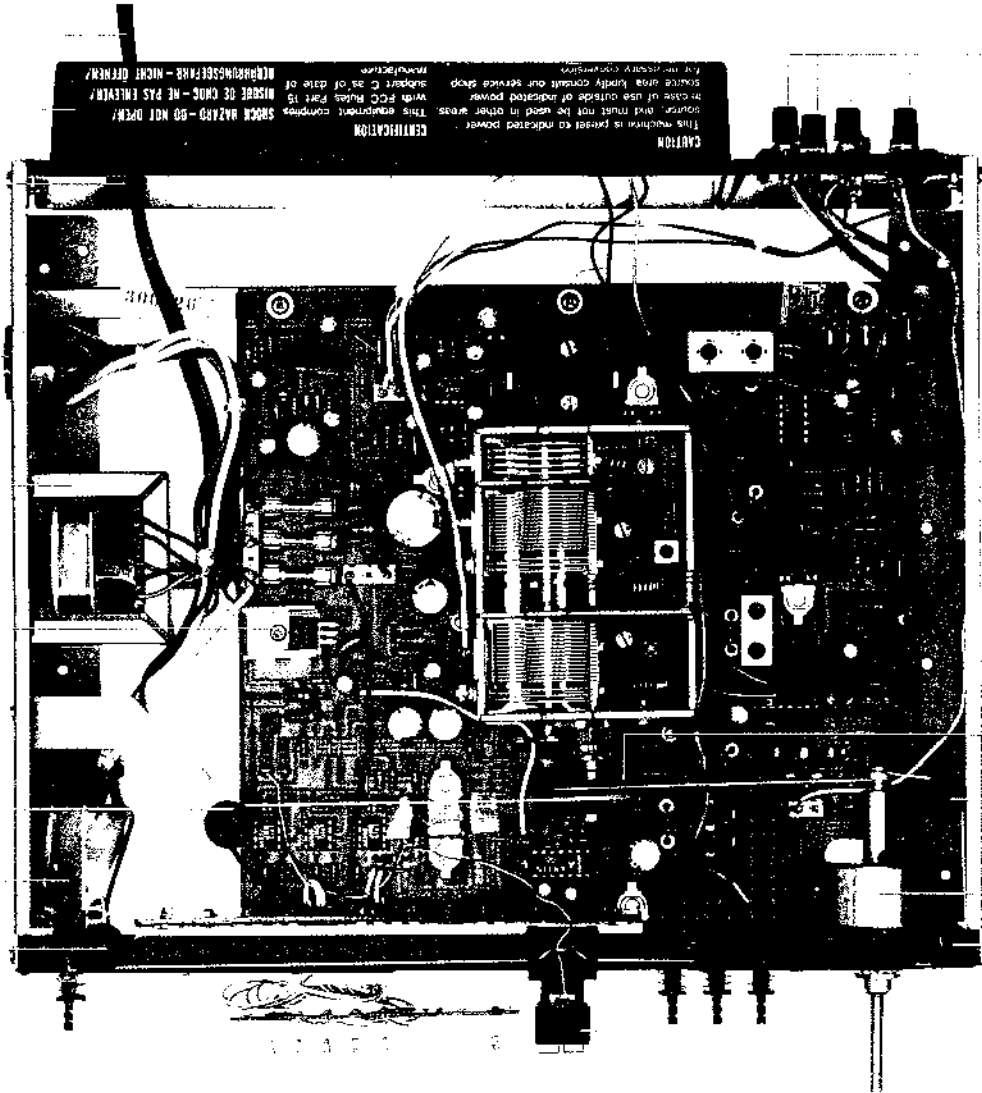

ASSEMBLY BLOCK

Ref. No.	Parts No.	Description	Schematic No.
4-1	BT704927	Δ Trans Power UC-K2 (U/T)	23-1238-0-0
4-2x	BT704941	Δ Trans Power UC-K2 (JPN)	23-1239-0-0
4-3x	BT704925	Δ Trans Power UC-K2 (AAL)	23-1236-0-0
4-4x	BT705195	Δ Trans Power UC-K2 (CSA)	23-1237-0-0
4-5x	BT704923	Δ Trans Power UC-K2 (CEE)	23-1234-0-0
4-6x	BT704924	Δ Trans Power UC-K2 (UK, SAA)	23-1235-0-0
4-7x	ZS422076	PAN30x05STL CMT A	
4-8x	ZW273745	SW30	
4-9x	ZW426587	PW31x080x050STL	
4-10	ES705007	Volt Change SW. ESE-372 (U/T)	81-150
4-11x	ZW281463	RV NYL30x065 BL	2-7-54
4-12	ES704990	Δ SW. Push UC-M2 (U/T, JPN, CSA, UK, SAA)	81-2124
4-13x	ES704991	Δ SW. Push UC-M2 (AAL)	81-2202
4-14x	ES704989	Δ SW. Push UC-M2 (CEE)	81-2220
4-15x	ZS379350	PAN30x06STL CMT	
4-16x	EC704996	Δ C CE DHS472MD (U/T, CEE)	
4-17x	EC705001	Δ C CE DDL472ZE (AAL, JPN)	
4-18x	EC704999	Δ C CE DEL472ZE (CSA)	
4-19x	EC704997	Δ C CE DGS222MD4(UK,SAA)	
4-20	EW705100	Δ AC Cord UC-M2 (U/T)	85-243-0-0
4-21x	EW705006	Δ AC Cord UC-M2 (JPN)	85-241-0-0
4-22x	EW704959	Δ AC Cord UC-K2 (AAL)	85-245-0-0
4-23x	EW705099	Δ AC Cord UC-M2 (CSA)	85-212-0-0
4-24x	EW705002	Δ AC Cord UC-M2 (CEE)	85-235-0-0
4-25x	EW705004	Δ AC Cord UC-M2 (UK)	85-240-0-0
4-26x	EW705098	Δ AC Cord UC-M2 (SAA)	85-242-0-0
4-27	EZ700844	Strain Relief 3P-4	62-361
4-28x	EE704922	Bar ANT UC-K2	11-582
4-29x	TA704964	ANT Holder UC-K2	62-331
4-30	TA704972	Bar ANT Cover UC-K2	51-352-0
4-31	TA704967	Dial Drum UC-K2	62-3325-0
4-32x	ZG704969	Dial Spring UC-K2	88-149-0
4-33	MR704971	Dial Pulley UC-K2	
4-34	EJ704963	Jack Plate UC-K2	82-2108
4-35	ZW231030	RV NYL30x045 BL	2-7-54
4-36	SP704885	Rear Panel A (U/T, JPN, AAL, CSA, SAA)	71-2427-0
4-37x	SP704914	Rear Panel B (CEE, UK)	71-2428-0
4-38	MI700845	Tuning Shaft	87-276
4-39x	ZW302896	N90STL CMT P075	
4-40	SA704973	Rubber Foot UC-K2	92-279-0
4-41x	ZS316638	T2BR30x06STL CMT TW	
4-42	ZS421806	PAN30x08STL CMT	
4-43x	ZW516993	N30STL CMT I	
4-44x	ZS472274	T2BID30x06STL CMT	
4-45x	ZS479474	PAN26x05STL CMT	
4-46x	ZS379405	BID30x06STL CMT	
4-47x	ZS306021	ST PAN30x06STL CMT	
4-48	ED704951	D LE LN224RP RED	LN224RP
4-49	TA700846	Pointer Assy	02-6044
4-50	ED704940	D LE LN324GP GRN	LN324GP

5. FINAL ASSEMBLY BLOCK

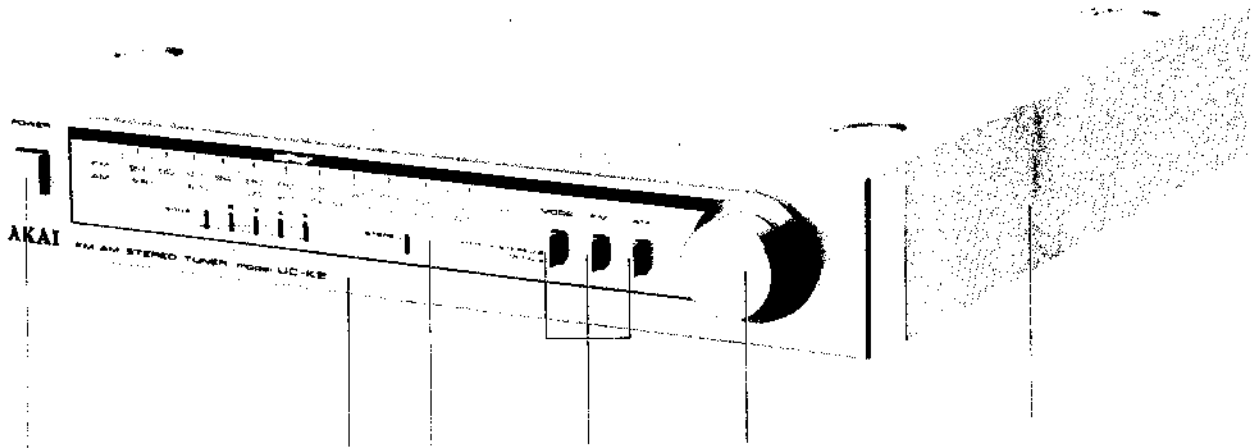

FINAL ASSEMBLY BLOCK

Ref. No.	Parts No.	Description	Schematic No.
5-1	BD704965	Front Panel BLK UC-K2	01 3379 42
5-2x	BD705012	Front Panel BLK UC-K2J	01 3379 42
5-3	TA704966	Dial Scale UC-K2	63 4191 0
5-4x	TA704911	Dial Scale UC-K2 (JPN)	63 4191 1
5-5	SB705110	Push Button UC-M2	62 155 0
5-6x	ZG705112	Button Spring UC-M2	88 154 0
5-7	SB705109	Push Button UC-M2	62 156 0
5-8x	ZG705113	Button Spring UC-M2	88 155 0
5-9	SK704915	Tuning Knob UC-K2	62 2217 0
5-10	SP704974	Upper Cover UC-K2	71 3059 0
5-11x	ZS472274	T2BID30×06STL CMT	
5-12x	ZS200676	T2CTS30×06STL CMT	
5-13x	ZS310344	CTS26×10STL CMT	

When ordering parts, please quote Parts Number, Description and Model Number.



II. MODEL UC-U2

1. RECOMMENDED SPARE PARTS LIST

Because, if the parts listed below are on hand, almost any repair can be accomplished, we suggest that you stock these Recommended Spare Parts Items.

Parts No.	Description	Notes
BA705077	Main Amp. P.C Board Comp. UC-U2	
BA705078	Selector SW. P.C Board Comp. UC-U2	
BT705119	△ Trans Power UC-U2 (AAL)	
BT705107	△ Trans Power UC-U2 (UK)	
BT705106	△ Trans Power UC-U2 (CEE)	
BT705118	△ Trans Power UC-U2 (JPN)	
BT705116	△ Trans Power UC-U2 (SAA)	
BT705117	△ Trans Power UC-U2 (U/T)	
BT705114	△ Trans Power UC-U2 (CSA)	
ED704829	D Germa 1S446	
ED704951	D LE LN224RP RED	
ED705048	D Silicon SR-1K	
ED704975	D Silicon S1VB	
ED705043	D Silicon S4VB-20	
ED705042	D Silicon 1S1588	
ED705064	D Varistor RB-262	
ED705127	D Zener BZ-280	
ED237960	D Zener H WZ-150	
ED306723	D Zener H 05Z10 U	
ED705039	D Zener WZ-056	
ED494627	D Zener WZ-162	
EF705029	△ Fuse GGS 2A	AAL
EF705024	△ Fuse GGS, 63/100A	AAL
EF704894	△ Fuse MF51NR 0.63A	JPN
EF705069	△ Fuse MF51NR 2A	JPN
EF705068	△ Fuse 1.6AF	Ext. AAL, JPN
EF705028	△ Fuse 1.6AT	CSA, U/T
EF704907	△ Fuse 200mAT	U/T, CSA, CEE, UK, SAA
EF704895	△ Fuse 630mAT	CEE, UK, SAA, U/T
EI705035	IC AN-6875	
EI700753	IC NJM4558D A	
EI705051	IC NJM4559D D	
EJ704896	Headphone Jack HLJ0252-01-060	
EL704893	Lamp 28V 40mA	
EO705067	Coil 25T 1.8MH	
EP705049	Relay HB-2 DC-24V	
ES704989	△ SW. Push UC-M2	CEE
ES704990	△ SW. Push UC-M2	U/T, JPN, UK, SAA
ES704991	△ SW. Push UC-M2	AAL, CSA
ES705031	SW. Push 4-Throw UC-U2	

Parts No.	Description	Notes
ES705033	SW. Rotary SRZ-L043	
ET293220	TR 2SA817 (O) (Y)	
ET705046	TR 2SA999	
ET705062	TR 2SB595 (Y)	
ET705059	TR 2SC1583 (G)	
ET293253	TR 2SC1627 (O) (Y)	
ET705061	TR 2SC982	
ET705063	TR 2SD525 (Y)	
EV705038	R S-Fix H EVNK4 3P 102	
EV705065	R S-Fix V EVNK0 3P 102	
EV705050	Vol. UC-U2	
EV705052	Vol. UC-U2	
EW704959	△ AC Cord UC-K2	AAL
EW705002	△ AC Cord UC-M2	CEE
EW705004	△ AC Cord UC-M2	UK
EW705006	△ AC Cord UC-M2	JPN
EW705098	△ AC Cord UC-M2	SAA
EW705099	△ AC Cord UC-M2	CSA
EW705100	△ AC Cord UC-M2	U/T
MZ705072	△ Volt Changer J-R1018	U/T

2. MAIN AMP P.C BOARD (72-1870) BLOCK

Symbol No.	Parts No.	Description	Schematic No.
2-1	BA705077	Main Amp P.C Board Comp. UC-U2	02 3055
2-Q701	ET705059	TR 2SC1583 (G)	2SC1583G
2-Q702	ET293220	TR 2SA817(O)(Y)	45-1-262
2-Q703	ET705061	TR 2SC982	2SC982
2-Q704	ET705063	TR 2SD525(Y)	2SD525Y
2-Q705,706	ET293253	TR 2SC1627(O)(Y)	45-1-263
2-Q707	ET293220	TR 2SA817(O)(Y)	45-1-262
2-Q708	ET705062	TR 2SB595(Y)	2SB595Y
2-D701	ED306723	D Zener H 05Z10 U	45-6-76
2-D702	ED705064	D Varistor RB-262	RB-262
2-L701	EO705067	Coil 25T 1.8MH	15-145
2-FU701,702	EF705068	△ Fuse 1.6AF (Ext. AAL, JPN)	
2-FU701,702	EF705029	△ Fuse GGS 2A (AAL)	
2-FU701,702	EF705069	△ Fuse MF51NR 2A (JPN)	
2-R703	ER326615	R CB H SNP FS RDS 1/4W 390Ω	35-11 30
2-R705	EV705065	R S-Fix V EVNKO 3P 102	41-771
2-R717	ER701012	R CT MPC-72 R47+R47	MPC 72

3. CONTROL, SELECTOR SW. P.C BOARD (72-1869) BLOCK

Symbol No.	Parts No.	Description	Schematic No.
3-1	BA705078	Selector SW. P.C Board Comp. UC-U2	02-7040
3-IC601	EI705051	IC NJM4559D D	NJM4559DD
3-D601	ED705127	D Zener BZ-280	BZ 280
3-S601	ES705031	SW. Push 4-Throw UC-U2	81 2219
3-S602	ES705033	SW. Rotary SRZ-L043 (Selector)	81 149
3-R607	EV705052	Vol. UC-U2 (Treble)	41 651
3-R610	EV705052	Vol. UC-U2 (Bass)	41 651
3-R615	EV705050	Vol. UC-U2 (Volume)	41 514
3-R616,617	ER558213	R MFH 1W 181J	35 15 10

4. POWER SUPPLY, PROTECTOR P.C BOARD (72-1867) BLOCK

Symbol No.	Parts No.	Description	Schematic No.
4-Q801to803	ET705046	TR 2SA999F-	2SA999F
4-Q804	ET293220	TR 2SA817(O)(Y)	45-1-262
4-D801	ED705042	D Silicon 1S1588	1S1588
4-D802,803	ED705048	D Silicon SR-1K	SR-1K
4-D804	ED705043	D Silicon S4VB-20	S4VB-20
4-RY801	EP705049	Relay HB-2 DC-24V	81 613
4-C805	EC705040	E EC 682 42V	
4-C806	EC267186	C MY V CQ92 334K 50DC	24 1-10
4-C807	EC705040	E EC 682 42V	
4-C808	EC267186	C MY V CQ92 334K 50DC	24 1-10
4-C809	EC700831	C MY V 224K 250DC	

5. EQ AMP P.C BOARD (72-1872) BLOCK

Symbol No.	Parts No.	Description	Schematic No.
5-IC501	EI700753	IC NJM4558D A	NJM4558DA
5-J501	EJ705070	Jack Plate UC-U2	82-2111

**6. LED DRIVER, DISPLAY P.C BOARD
(72-1866) BLOCK**

Symbol No.	Parts No.	Description	Schematic No.
6-IC201	EI705035	IC AN-6875	AN-6875
6-IC251	EI705035	IC AN-6875	AN-6875
6-D201,202	ED704829	D Germa 1S446	1S446
6-D203	ED705039	D Zener WZ-056	WZ-056
6-D204to208	ED704951	D LE LN224RP RED	LN224RP
6-D209	ED494627	D Zener WZ-162	45-6-67
6-D251,252	ED704829	D Germa 1S446	1S446
6-D253	ED705039	D Zener WZ-056	WZ-056
6-D254to258	ED704951	D LE LN224RP RED	LN224RP
6-R202	EV705038	R S-Fix H EVNK4 3P 102	41-764
6-R252	EV705038	R S-Fix H EVNK4 3P 102	41-764

**7. PRE AMP POWER SUPPLY P.C BOARD
(72-1871) BLOCK**

Symbol No.	Parts No.	Description	Schematic No.
7-D901,902	ED237960	D Zener H WZ-150	45-6-67
7-D903	ED704975	D Silicon S1VB	S1VB
7-R901,902	ER449728	R MF H 1W 561K	35-15-16
7-C901,902	EC324665	C EC V CUT USM 471M 16.0DC	24-12-60
7-C903,904	EC322453	C EC V CUT USM 102M 25.0DC	24-12-60
7-FU901,902	EF704907	Δ Fuse 200mAT (U/T,CSA,CEE,UK,SAA)	
7-FU901,902	EF705024	Δ Fuse GGS, 63/100A (AAL)	
7-FU901,902	EF704894	Δ Fuse MF51NR 0.63A (JPN)	
7-FU903	EF705028	Δ Fuse 1.6AT (U/T)	
7-FU903	EF704895	Δ Fuse 630mAT (U/T)	
7-FU903	EF704895	Δ Fuse 630mAT (CEE, UK, SAA)	
7-FU903	EF705028	Δ Fuse 1.6AT (CSA)	
7-FU903	EF705029	Δ Fuse GGS 2A (AAL)	
7-FU903	EF705069	Δ Fuse MF51NR 2A (JPN)	

8. ASSEMBLY BLOCK

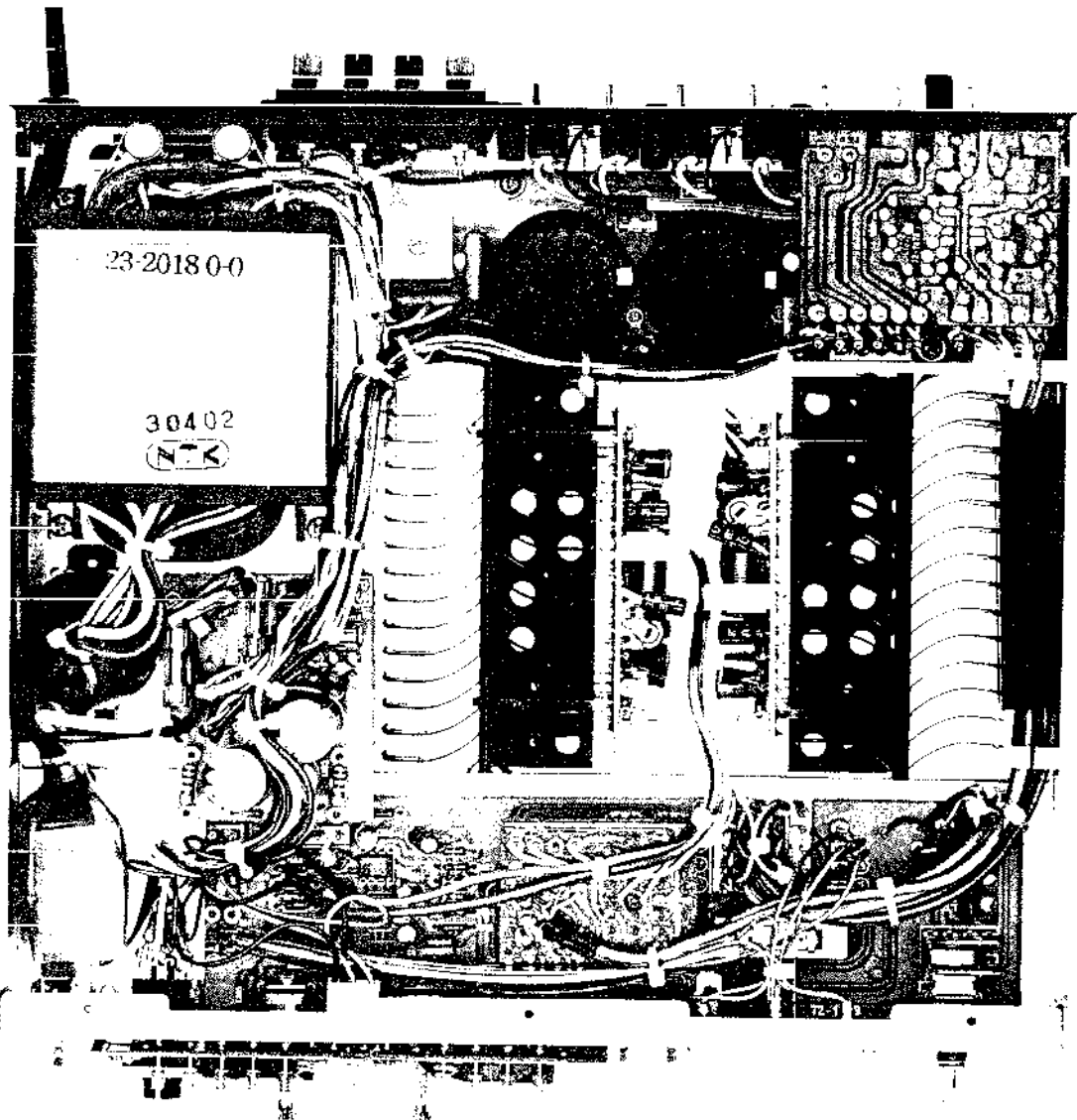
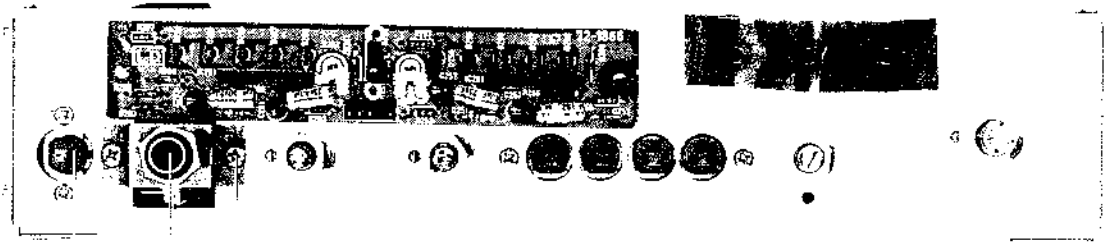

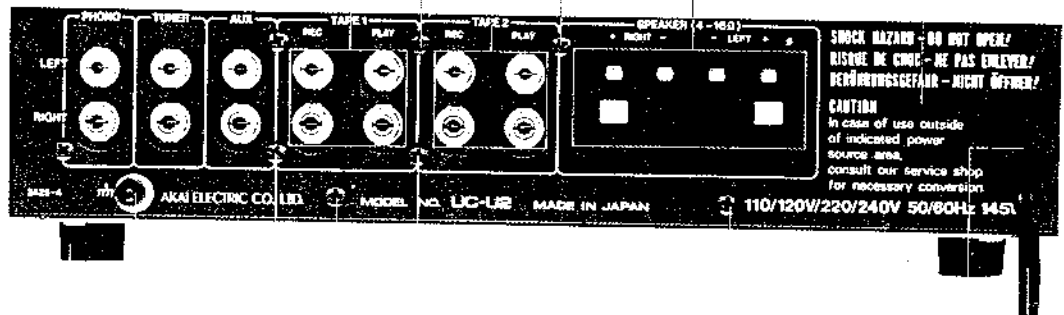

ASSEMBLY BLOCK

Part No.	Part No.	Description	Part No.	Part No.	Description
8-1	ES704990	△ SW. Push UC-52 (CUT, JPN, U.K., SAA)	8-26x	ZW682408	FW 32-100-08STL NLT
8-2	ES704991	△ SW. Push UC-M2 (AAL, CSA)	8-27	FW705006	△ AC Cord UC-M2 (JPN)
8-3x	ES704989	△ SW. Push UC-M2 (CEE)	8-28x	FW705006	△ AC Cord UC-M2 (JPN)
8-4	ZS422676	PAN 30-08STL CMT A	8-29x	FW704959	△ AC Cord UC-K2 (AAL)
8-5	EC704996	△ C CE DHS472MD (U.K., CEE)	8-30x	FW705099	△ AC Cord UC-M2 (CSA)
8-6x	EC705001	△ C CE DPL472ZE (JPN, AAL)	8-31x	FW705002	△ AC Cord UC-M2 (CEE)
8-7x	EC704999	△ C CE DEL472ZE (CSA)	8-32x	FW705004	△ AC Cord UC-M2 (UK)
8-8x	EC704997	△ C CE DGS222MD4 (U.K., SAA)	8-33x	FW705098	△ AC Cord UC-M2 (SAA)
8-9	EJ704896	Headphone Jack HLI0252-01 060	8-34	EZ700844	Strain Relief 3P-4
8-10	ZS472274	T2BD30-06STL CMT	8-35x	MZ705072	Volt Changer J-R101S (U.K., JPN)
8-11x	ER704898	R.M.F. 1 151J	8-36	SA704973	Rubber Foot UC-K2
8-12	FL704893	Lamp 28V-40mA	8-37x	ZS674537	T2BR30-06STL CMT PW-50
8-13	FJ704901	SP Terminal S-Q2361	8-38	SP705090	Rear Panel UC-U2 (U/T)
8-14	EJ704899	Jack Plate J-5500-D	8-39x	SP705091	Rear Panel UC-U2 (JPN)
8-15	ZS453353	T2BR30-08STL BNI	8-40x	SP705068	Rear Panel UC-U2 (AAL)
8-16	IJ705026	GND Terminal UB-0005	8-41x	SP705089	Rear Panel UC-U2 (CSA)
8-17	BI705117	△ Trans Power UC-U2 (U/T)	8-42x	SP705083	Rear Panel UC-U2 (CEE)
8-18	BI705118	△ Trans Power UC-U2 (JPN)	8-43x	SP705084	Rear Panel UC-U2 (UK)
8-19	BT705119	△ Trans Power UC-U2 (AAL)	8-44x	SP705092	Rear Panel UC-U2 (SAA)
8-20x	BI705114	△ Trans Power UC-U2 (CSA)	8-45	ZS5895 (1)	T2BD1030-06STL BNI
8-21x	BI705106	△ Trans Power UC-U2 (CEE)	8-46	ZS202511	RND30-18STL CMT
8-22x	BI705107	△ Trans Power UC-U2 (UK)	8-47x	ZW516993	NA08STL CMT 1
8-23x	BI705116	△ Trans Power UC-U2 (SAA)	8-48x	ZS313166	RND30-06STL CMT
8-24	ZS480228	T2BD30-08STL CMT	8-49x	ZS325495	T2BR30-06STL CMT
8-25	ZS321298	BD30-08STL CMT	8-50x	ZS472274	T2BD30-06STL CMT

When ordering parts, please quote Part Number, Description and Model Number

9. FINAL ASSEMBLY BLOCK

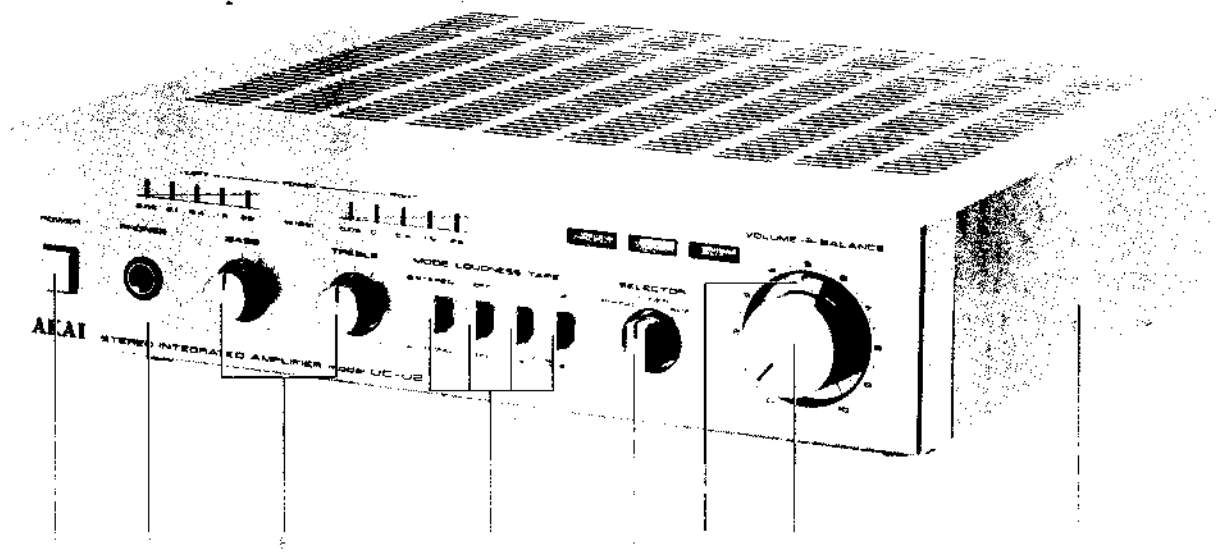

FINAL ASSEMBLY BLOCK

Ref. No.	Parts No.	Description	Schematic No.
9-1	BD705073	Front Panel BLK UC-U2	01 3380 42
9-2	SB705110	Push Button UC-M2	62 155-0
9-3x	ZG705113	Button Spring UC-M2	88 155 0
9-4	SB705109	Push Button UC-M2	62 156 0
9-5x	ZG705112	Button Spring UC-M2	88 154 0
9-6	SK705080	Vol. Knob (Upper) UC-U2	62 2221 0
9-7	SK705087	Vol. Knob (Lower) UC-U2	62 2220 0
9-8	SK705086	Tone Vol. Knob UC-U2	62 2218-0
9-9	SK705013	Selector Knob UC-M2	62 2219 0
9-10	SP705094	Upper Cover UC-U2	71 3063 0

When ordering parts, please quote Parts Number, Description and Model Number.

III. MODEL UC-M2

1. RECOMMENDED SPARE PARTS LIST

Because, if the parts listed below are on hand, almost any repair can be accomplished, we suggest that you stock these Recommended Spare Parts Items.

Parts No.	Description	Notes
BA704840	OSC P.C Board Comp. UC-M2	
BA704837	REC/PB P.C Board Comp. UC-M2	
BF705173	Flywheel Assy	
BH705023	Head BLK	
BL705158	FF/REW Arm Assy	
BL705139	Idler Assy	
BM705176	Motor	
BR705164	Supply Reel Table Assy	
BR705167	Take-up Reel Table Assy	
BT704985	△ Trans Power UC-M2 (AAL)	
BT704984	△ Trans Power UC-M2 (UK, SAA)	
BT704986	△ Trans Power UC-M2 (CSA)	
BT704983	△ Trans Power UC-M2 (CEE)	
BT704988	△ Trans Power UC-M2 (JPN)	
BT704987	△ Trans Power UC-M2 (U/T)	
BZ705163	Solenoid	
BZ705174	Solenoid	
ED704951	D LE LN224RP RED	
ED704940	D LE LN324GP GRN	
ED704866	D Silicon SR1K	
ED322238	D Silicon 1B4B41 100/1.0A	
ED704827	D Silicon 1S1555	
ED704849	D Zener WZ130	
ED704869	D Zener WZ290	
EF704892	△ Fuse GGS 0.63A	AAL
EF704897	△ Fuse GGS 0.8A	AAL
EF704894	△ Fuse MF51NR 0.63A	U/T, JPN
EF704900	△ Fuse MF51NR 0.8A	U/T, JPN
EF704889	△ Fuse 400mAT	CSA, CEE, UK, SAA
EF704895	△ Fuse 630mAT	CSA, CEE, UK, SAA
EI704937	IC BA682	
EI306141	IC LA4170	
EI704853	IC LM1011N	
EI310036	IC TC4066BP	
EJ705008	△ AC Outlet S2-723B-1-0	JPN
EJ705009	△ AC Outlet S2-723B-50	U/T, CSA, AAL
EJ704953	Headphone Jack UC-M2	
EJ704954	MIC Jack UC-M2	
EJ704955	Pin Jack UC-M2	
EO704868	Choke Coil 4.7MH	

Parts No.	Description	Notes
EO704904	Coil OSC UC-M2	
ER705032	Low Pass Filter UC-M2	
ES704989	△ SW. Push UC-M2	CEE
ES704990	△ SW. Push UC-M2	U/T, JPN, UK, SAA
ES704991	△ SW. Push UC-M2	AAL, CSA
ES705007	△ Volt Change SW. ESE-372	U/T
ES704976	Slide SW. UC-M2	
ES705160	SW. Leaf	
ES705192	SW. Push	
ES704933	SW. Push UC-M2	
ES704936	SW. Push UC-M2	
ES704977	SW. Reed ORD-225	
ES704905	SW. Rotary UC-M2	
ES705151	SW. Schelton	
ES704903	SW. Slide UC-M2	
ET704850	TR 2SA1020 (O)	
ET356984	TR 2SA564 (R)	
ET309860	TR 2SA684 (R)	
ET704817	TR 2SA721 (T)	
ET704814	TR 2SC1327 (T)	
ET704852	TR 2SC1327 (U)	
ET300632	TR 2SC1384 (R) (S)	
ET308980	TR 2SC1815 (GR)	
ET234933	TR 2SC828 (R)	
ET704865	TR 2SC828 (S)	
ET704851	TR 2SD880 (Y)	
EV704934	R Rotary 20KDx2	
EV704857	R S-Fix H EVN-KA 3P 203	
EV704929	R S-Fix H EVN-K4 3P 104	
EV704939	R S-Fix H EVN-K4 3P 501	
EV704938	R S-Fix H EVN-K4 3P 502	
EV704928	R S-Fix H EVN-K4 3P 503	
EW705002	△ AC Cord UC-M2	CEE
EW705004	△ AC Cord UC-M2	UK
EW705006	△ AC Cord UC-M2	JPN
EW705098	△ AC Cord UC-M2	SAA
EW705099	△ AC Cord UC-M2	AAL, CSA
EW705100	△ AC Cord UC-M2	U/T
HE705030	Erase Head	
HP705045	REC/PB Head	

Parts No.	Description	Notes
MB705155	Counter Belt	
MB705171	Drive Belt	
MB705159	FF Belt	
MB705147	Middle Belt	
MC704956	Counter MP390-423	
MI705138	PB Idler	
ML705156	FF/REW Lever	
MP704950	Pinch Roller BLK	

2. REC/P.B P.C BOARD (72-1864) BLOCK

Symbol No.	Parts No.	Description	Schematic No.	Symbol No.	Parts No.	Description	Schematic No.
2-1	BA704837	REC/PB P.C Board Comp. UC-M2	02-433	2-C207	EC646391	C TT V DTS 101K 10.0DC	24-15-8
2-IC101	EI704853	IC LM1011N	LM1011N	2-C213	EC704861	C EC V MS 4R7 50.0DC	
2-IC102	EI306141	IC LA4170	45-8-305	2-C214	EC704860	C EC V MS R33 50.0DC	
2-IC103	EI310036	IC TC4066BP	45-8-289	2-C217	EC704863	C PP 5601G 50.0DC	
2-IC201	EI704853	IC LM1011N	LM1011N	2-C218	EC704864	C PP 2702G 50.0DC	
2-Q101	ET704817	TR 2SA721(T)	2SA721T	2-C219	EC704862	C PP 4701G 50.0DC	
2-Q102,103	ET704814	TR 2SC1327(T)	2SC1327T	2-C221	EC651115	C TT V DTS 100M 25.0DC	24-15-8
2-Q104	ET308980	TR 2SC1815(GR)	45-1-299	2-C231	EC704860	C EC V MS R33 50.0DC	
2-Q105	ET704852	TR 2SC1327(U)	2SC1327U	2-FU101	EF704900	Δ Fuse MF51NR 0.8A (U/T, JPN)	
2-Q106,107	ET704865	TR 2SC828(S)	2SC828S	2-FU101	EF704897	Δ Fuse GGS 0.8A (AAL)	
2-Q108to114	ET308980	TR 2SC1815(GR)	45-1-299	2-FU101	EF704895	Δ Fuse 630mAT (CSA, CEE, UK, SAA)	
2-Q115	ET704865	TR 2SC828(S)	2SC828S	2-FU102	EF704894	Δ Fuse MF51NR 0.63A (U/T, JPN)	
2-Q116	ET704850	TR 2SA1020(O)	2SA1020O	2-FU102	EF704892	Δ Fuse GGS 0.63A (AAL)	
2-Q117	ET356984	TR 2SA564(R)	45-1-44	2-FU102	EF704889	Δ Fuse 400mAT (CSA, CEE, UK, SAA)	
2-Q118,119	ET234933	TR 2SC828(R)	45-1-23				
2-Q120	ET309860	TR 2SA684(R)	45-1-320				
2-Q121	ET704851	TR 2SD880(Y)	2SD880Y				
2-Q201	ET704817	TR 2SA721(T)	2SA721T				
2-Q202,203	ET704814	TR 2SC1327(T)	2SC1327T				
2-Q204	ET308980	TR 2SC1815(GR)	45-1-299				
2-Q205	ET704852	TR 2SC1327(U)	2SC1327U				
2-Q206,207	ET704865	TR 2SC828(S)	2SC828S				
2-Q208to214	ET308980	TR 2SC1815(GR)	45-1-299				
2-D101to103	ED704827	D Silicon 1S1555	1S1555				
2-D104to107	ED704866	D Silicon SR1K	SR1K				
2-D108,109	ED704849	D Zener WZ130	WZ130				
2-D110	ED704827	D Silicon 1S1555	1S1555				
2-D111	ED704869	D Zener WZ290	WZ290				
2-D112,113	ED322238	D Silicon 1B4B41					
		100/1.0A	45-2-97				
2-D114,115	ED704827	D Silicon 1S1555	1S1555				
2-D201	ED704827	D Silicon 1S1555	1S1555				
2-S101	ES704903	SW. Slide UC-M2	81-419				
2-S201	ES704903	SW. Slide UC-M2	81-419				
2-FL101	ER705032	Low Pass Filter UC-M2	19-116				
2-FL201	ER705032	Low Pass Filter UC-M2	19-116				
2-L101to104	EO704868	Choke Coil 4.7MH	14-311				
2-L201to204	EO704868	Choke Coil 4.7MH	14-311				
2-R120	EV704857	R S-Fix H EVN-KA					
		3P 203	41-754				
2-R123	ER311773	R MF H 1/4W 3301F	35-17-12				
2-R131	ER704854	R OMF H 1W 122J					
2-R137to140	EV704857	R S-Fix H EVN-KA					
		3P 203	41-754				
2-R159,160	ER366028	R OMF H 1W 391J	35-15-10				
2-R161	ER496833	R OMF H 1W 471J	35-15-10				
2-R187	ER704870	R OMF H 2W 220J					
2-R220	EV704857	R S-Fix H EVN-KA					
		3P 203	41-754				
2-R223	ER311773	R MF H 1/4W 3301F	35-17-12				
2-R231	ER704854	R OMF H 1W 122J					
2-R237to240	EV704857	R S-Fix H EVN-KA					
		3P 203	41-754				
2-C101	EC434070	C STY V 681J 50DC	24-11-3				
2-C104	EC704855	C TT 4R7 16V					
2-C107	EC646391	C TT V DTS 101K 10.0DC	24-15-8				
2-C113	EC704861	C EC V MS 4R7 50.0DC					
2-C114	EC704860	C EC V MS R33 50.0DC					
2-C117	EC704863	C PP 5601G 50.0DC					
2-C118	EC704864	C PP 2702G 50.0DC					
2-C119	EC704862	C PP 4701G 50.0DC					
2-C121	EC651115	C TT V DTS 100M 25.0DC	24-15-8				
2-C131	EC704860	C EC V MS R33 50.0DC					
2-C142	EC316183	C EC V CUT H 102M 16.0DC	24-12-46				
2-C161	EC316182	C EC V CUT H 222M 16.0DC	24-12-46				
2-C166	EC316183	C EC V CUT H 102M 16.0DC	24-12-46				
2-C201	EC434070	C STY V 681J 50DC	24-11-3				
2-C204	EC704855	C TT 4R7 16V					

When ordering parts, please quote Parts Number, Description and Model Number.

3. OSC P.C BOARD (72-1865) BLOCK

Symbol No.	Parts No.	Description	Schematic No.
3-1	BA704840	OSC P.C Board Comp. UC-M2	02-5041
3-Q501,502	ET300632	TR 2SC1384(R)(S)	45-1-173
3-S501	ES704905	SW, Rotary UC-M2	81-148
3-L501	EO704904	Coil OSC UC-M2	12-712
3-R503to505	EV704929	R S-Fix H EVN-K4 3P 104	
3-R506	EV704928	R S-Fix H EVN-K4 3P 503	
3-R507to509	EV704929	R S-Fix H EVN-K4 3P 104	
3-R510	EV704928	R S-Fix H EVN-K4 3P 503	
3-R511	ER416373	R OMH H 1W 221J	35-15-10
3-C503	EC704931	C STY 272J 250DC	
3-C504	EC423810	C STY V 222J 50DC	24-11-3
3-C505	EC469708	C STY V 102J 50DC	24-11-3
3-C509	EC469708	C STY V 102J 50DC	24-11-3

5. SELECTOR P.C BOARD (72-1851) BLOCK

Symbol No.	Parts No.	Description	Schematic No.
5-S401	ES704933	SW, Push UC-M2	81-2218
5-S402	ES704936	SW, Push UC-M2	81-2223
5-R401	EV704934	R Rotary 20kD×2	41-512

6. LED P.C BOARD (72-1852) BLOCK

Symbol No.	Parts No.	Description	Schematic No.
6-D401	ED704951	D LE LN224RP RED	LN224RP
6-D402	ED704940	D LE LN324GP GRN	LN324GP

4. LED IND. P.C BOARD (72-1853) BLOCK

Symbol No.	Parts No.	Description	Schematic No.
4-IC301	EI704937	IC BA682	BA682
4-IC351	EI704937	IC BA682	BA682
4-D301to308	ED704940	D LE LN324GP GRN	LN324GP
4-D309to312	ED704951	D LE LN224RP RED	LN224RP
4-D351to358	ED704940	D LE LN324GP GRN	LN324GP
4-D359to362	ED704951	D LE LN224RP RED	LN224RP
4-R305	EV704939	R S-Fix H EVN-K4 3P 501	41-766
4-R306	EV704938	R S-Fix H EVN-K4 3P 502	41-758
4-R355	EV704939	R S-Fix H EVN-K4 3P 501	41-766
4-R356	EV704938	R S-Fix H EVN-K4 3P 502	41-758

7. MECHA ASSEMBLY BLOCK (1)

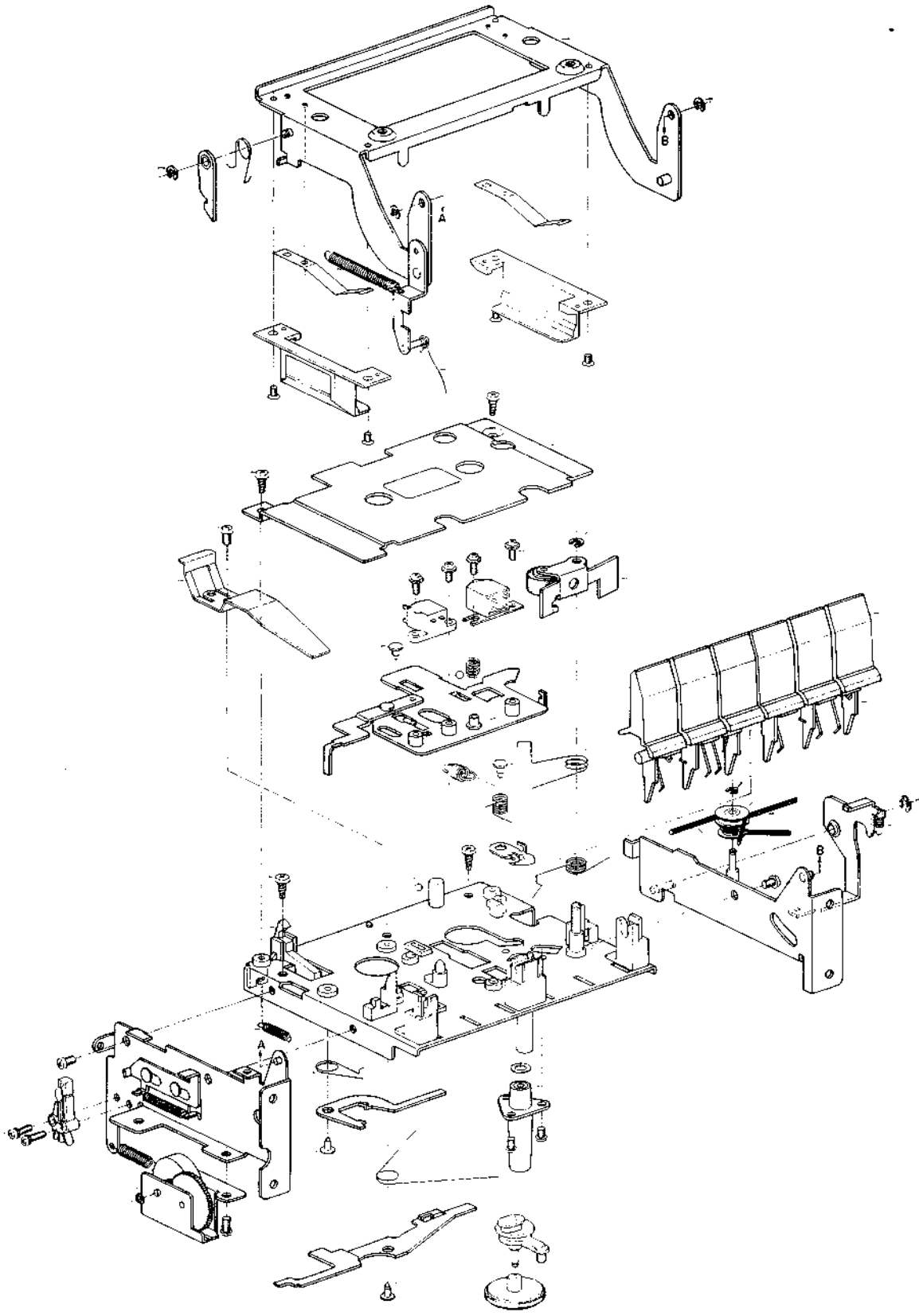

MECHA ASSEMBLY BLOCK (1)

Ref. No.	Parts No.	Description	Schematic No.
7-1	TC704839	Main Chassis	FC652-14
7-2	ZG704858	Holder Lock Return Spring	FK318-11
7-3	ZG704859	REC Prevention Spring	FK317-11
7-4	TC704944	Cap	FC728-12
7-5	ZS300506	ST PAN30x05STL CMT	
7-6	MV704945	Housing Assy	FM237 11
7-7	ZW704947	Oil Seal	FJ141-11
7-8	ZG704948	Idler Clamp Spring	FK320-12
7-9	ZG704949	Pinch Roller Spring	FK321-12
7-10	MP704950	Pinch Roller BLK	F014-037
7-11	ZW410051	Ring E 250SUP CMT	6-1-9
7-12	ZS303225	T2BIND30x10STL CMT	
7-13	TC704958	Detection Claw	FC631 12
7-14	ZG704960	Spring	FK322-12
7-15	ZG704961	Plate Spring	FK302-12
7-16	ZG704962	Head Base Spring	FK436-12
7-17	BH705023	Head BLK	F013-051
7-18	MV522235	Ball 3/32IN STL	
7-19	HE705030	Erase Head	F030-040
7-20	ZS705037	F Lock Screw	FG119-19
7-21	ZG705044	Azimuth Spring	FK362-11
7-22	HP705045	REC/PB Head	F029-065
7-23	ZW705005	Luminar	FJ123-14
7-24	MI705138	PB Idler	FP278-13
7-25	BL705139	Idler Assy	FC643 12
7-26	MZ705140	Cam Pause	FC714-11
7-27	ZG705141	Cam Pause Return Spring	FK316-11
7-28	TC705142	Decoration Plate	F184-011
7-29	ZS609120	T2PAN30x06STL CMT	
7-30	TC705143	Cassette Support	F027 037
7-31	TC705144	Operation Lever Assy	F132 022
7-32	ZG704952	Absentee Spring	FK514-11
7-33	MR705145	Idler Pulley	FP315-12
7-34	ZW356657	Ring E 150SUP CMT	6-1-9
7-35	ZG705146	Damper Spring	FK419-12
7-36	MB705147	Middle Belt	FP380-11
7-37	ZW705187	Ring E 200	KG111-19
7-38	ZG705149	SW. Operation Spring	FK462-11
7-39	ES705151	SW. Schelton	FE146-11
7-40	ZS705188	T2BIN20x08 PW040	FG114-22
7-41	ZG705152	Damper Spring (B)	FK459 11
7-42	TC705153	Wire Assy	F081-013
7-43	TC705154	Damper Assy	F077-013
7-44	MB705155	Counter Belt	FP444 11
7-45	SK704932	Key Knob UC-M2	62-154-0

When ordering parts, please quote Parts Number, Description and Model Number.

8. MECHA ASSEMBLY BLOCK (2)

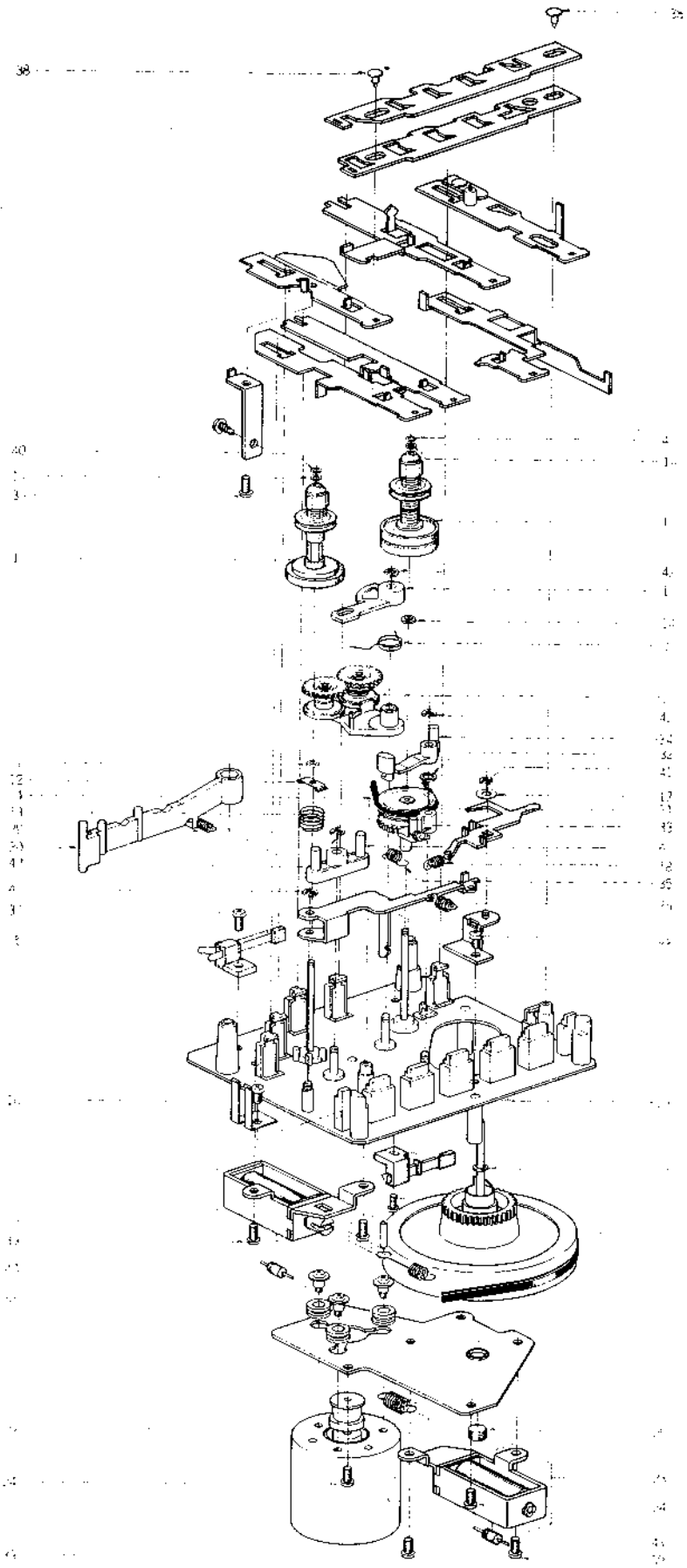

MECHA ASSEMBLY BLOCK (2)

Ref. No.	Parts No.	Description	Schematic No.
8-1	ML705156	FF/REW Lever	FC640-12
8-2	ZG705157	Clamp Spring	FK325-11
8-3	BL705158	FF/REW Arm Assy	FP276-13
8-4	MB705159	FF Belt	FP307-11
8-5	ES705160	SW. Leaf	FE143-11
8-6	TC705162	Change Lever	FC641-11
8-7	BZ705163	Solenoid	F082-016
8-8	ES705192	SW. Push	F179-015
8-9	ZS321194	ST PAN26x05STL CMT	
8-10	BR705164	Supply Reel Table Assy	FP280-11
8-11	ZW321317	PW21x040x050P SL	
8-12	ZW705193	Hold Washer	FC865-11
8-13	ZG705166	Back Tension Spring	FK313-11
8-14	ZW305546	PW21x040x025P SL	
8-15	BR705167	Take-up Reel Table Assy	FP345A11
8-16	ZG705168	Return Spring	FK303-14
8-17	ZW705190	Washer	FC388-13
8-18	ZG705169	Shut-off Plate Return Spring	FK315-12
8-19	BZ705170	Sub Chassis	F127-018
8-20	ZW324417	PW31x060x050P SL	
8-21	MB705171	Drive Belt	FP431-11
8-22	BF705173	Flywheel Assy	FP388-11
8-23	BZ705174	Solenoid	F082-018
8-24	ZS283454	PAN26x06STL CMT PW050	
8-25	TC705175	Spacer	FM123-11
8-26	BM705176	Motor	F064-053
8-27	SZ705177	Rubber Cushion	FJ115-11
8-28	ZS705178	Screw	FG171-11
8-29	ZG705179	SW. Lever Spring	FK348-12
8-30	ES705180	SW. Lever	FC841-11
8-31	BZ705181	Clutch FF Assy	F021-013
8-32	ZW621404	PW26x080x025P SL	
8-33	ZG705182	Coupling Spring	FK326-11
8-34	TC705184	CUE Arm	FC642-11
8-35	ZG705185	FF/REW Clutch Return Spring	FK446-12
8-36	ZG705186	Lever Return Spring	FK399-11
8-37	ZS306021	ST PAN30x06STL CMT	
8-38	TC704944	Cap	FC728-12
8-39	ZS300506	ST PAN30x05STL CMT	
8-40	ZW705005	Luminar	FJ123-14
8-41	ZW356657	Ring E 150SUP CMT	61-9
8-42	ZW705187	Ring E 200	KG111-19
8-43	ED704866	D Silicon SR1K	SR1K

9. ASSEMBLY BLOCK

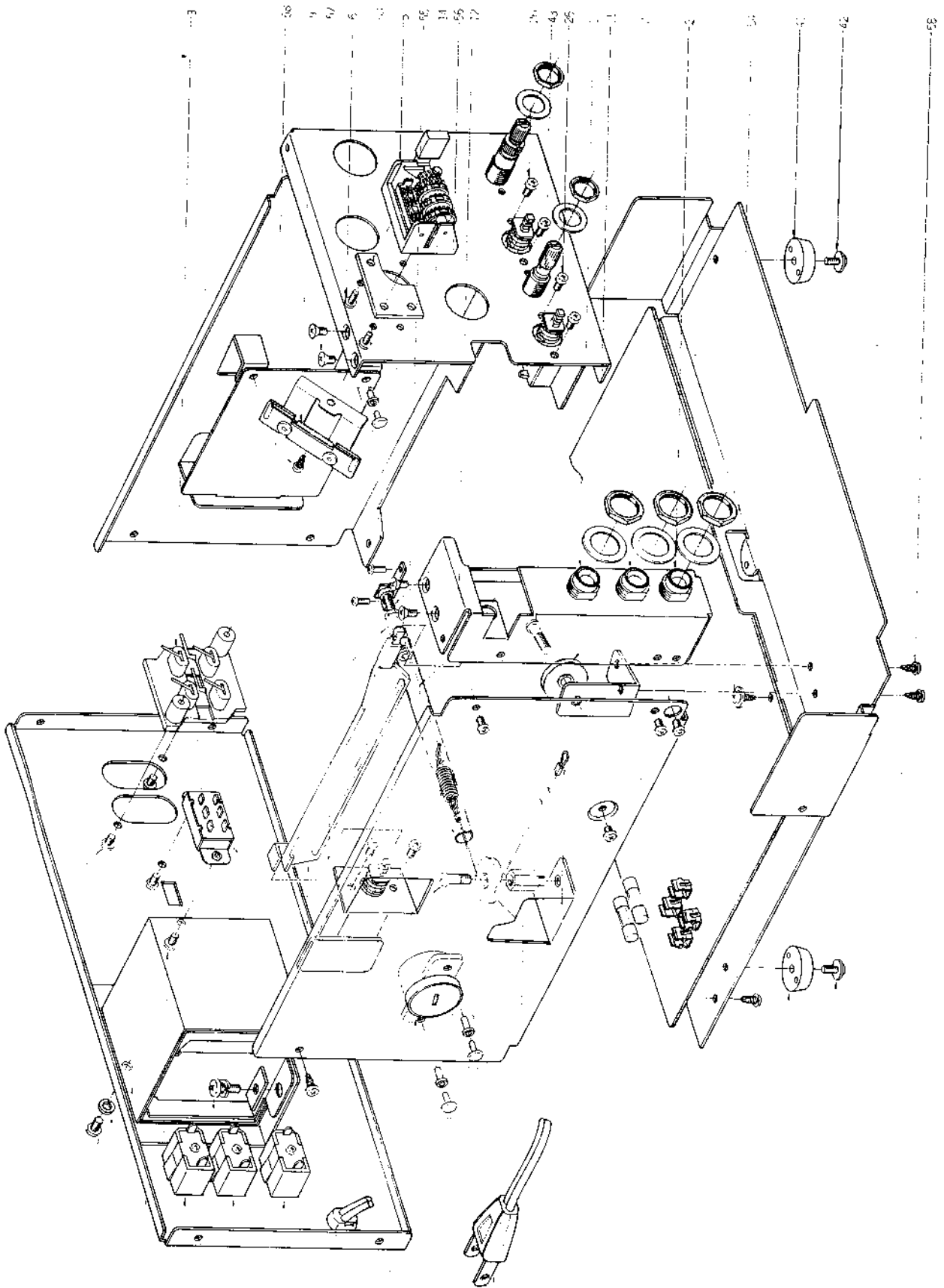

ASSEMBLY BLOCK

Ref. No.	Parts No.	Description	Schematic No.
9-1	EJ704953	Headphone Jack UC-M2	82-2114
9-2	EJ704954	MIC Jack UC-M2	82-2115
9-3	EJ704955	Pin Jack UC-M2	82-2109
9-4	ZS463353	T2BR30x08STL BNI	
9-5	MC704956	Counter MP390-423	MP390-423
9-6	ZS413166	RND30x06STL CMT	
9-7	ES704976	Slide SW. UC-M2	81-421-0
9-8	ZS304806	BID30x05STL BNI	
9-9	ES704977	SW. Reed ORD-225	ORD-225
9-10	MZ704978	SW. Joint UC-M2	62-3213-0
9-11	MR704979	Dial Pulley UC-M2	62-3161
9-12	ZG704980	Coil Spring UC-M2	88-142
9-13	TC704982	Coupling Wire 0.07x7x7	87-6001
9-14	ZS419872	BID30x20STL CMT	
9-15	ZS704995	Screw	87-3158
9-16	BT704987	Δ Trans Power UC-M2 (U/T)	23-1244-0
9-17x	BT704988	Δ Trans Power UC-M2 (JPN)	23-1245-0
9-18x	BT704985	Δ Trans Power UC-M2 (AAL)	23-1242-0
9-19x	BT704986	Δ Trans Power UC-M2 (CSA)	23-1243-0
9-20x	BT704983	Δ Trans Power UC-M2 (CEE)	23-1240-0
9-21x	BT704984	Δ Trans Power UC-M2(UK,SAA)	23-1241-0
9-22	ZS563297	BID40x08STL CMT SW	
9-23	ES704990	Δ SW. Push UC-M2 (U/T, JPN, UK, SAA)	81-2124
9-24x	ES704991	Δ SW. Push UC-M2 (AAL, CSA)	81-2202
9-25x	ES704989	Δ SW. Push UC-M2 (CEE)	81-2220
9-26	ZS384131	RND30x05STL CMT	
9-27x	EC704996	Δ C CE DHS472MD (U/T, CEE)	
9-28x	EC704997	Δ C CE DGS222MD4 (UK, SAA)	
9-29x	EC705001	Δ C CE DDL472ZE (AAL, JPN)	
9-30x	EC704999	Δ C CE DEL472ZE (CSA)	
9-31	EW705100	Δ AC Cord UC-M2 (U/T)	85-243-0-0
9-32x	EW705006	Δ AC Cord UC-M2 (JPN)	85-241-0-0
9-33x	EW705099	Δ AC Cord UC-M2 (AAL, CSA)	85-212-0-0
9-34x	EW705002	Δ AC Cord UC-M2 (CEE)	85-235-0-0
9-35x	EW705004	Δ AC Cord UC-M2 (UK)	85-240-0-0
9-36x	EW705098	Δ AC Cord UC-M2 (SAA)	85-242-0-0
9-37	ES705007	Δ Volt Change SW. ESE-372 (U/T)	81-150
9-38	ZW281463	RV NYL30x065 BL (U/T)	2-7-54
9-39	EJ705009	Δ AC Outlet S2-723B-50 (U/T, CSA, AAL)	82-2113
9-40x	EJ705008	Δ AC Outlet S2-723B-1-0 (JPN)	82-298-0
9-41	SA704973	Rubber Foot UC-K2	92-279-0
9-42	ZS674537	T2BR30x06STL CMT PW080	
9-43	ZS705000	Pulley Screw UC-M2	
9-44	SP705020	Rear Panel UC-M2 (U/T)	71-2420-2
9-45x	SP705021	Rear Panel UC-M2 (JPN)	71-2420-3
9-46x	SP705019	Rear Panel UC-M2 (AAL)	71-2420-1
9-47x	SP705018	Rear Panel UC-M2 (CSA)	71-2420-0
9-48x	SP705015	Rear Panel UC-M2 (CEE)	71-2419-0
9-49x	SP705016	Rear Panel UC-M2 (UK)	71-2419-1
9-50x	SP705017	Rear Panel UC-M2 (SAA)	71-2419-2
9-51	ZS537074	BID40x06STL BNI	
9-52	ZW668621	SW40 BDY	
9-53	ZW231030	RV NYL30x045 BL	2-7-54
9-54	ZS674537	T2BR30x06STL CMT PW080	
9-55	ZWS16993	N30STL CMT I	
9-56	TC704847	Coupling Wire UC-M2	87-6011-0
9-57	ZS200384	CTS30x06STL CMT	
9-58	ZS472274	T2BID30x06STL CMT	
9-59	EZ700844	Strain Relief 3P-4 (U/T, JPN, AAL, CSA, SAA)	62-361
9-60x	EZ631945	Strain Relief SR-4N04 (CEE, UK)	2-7-49

When ordering parts, please quote Parts Number, Description and Model Number.

10. FINAL ASSEMBLY BLOCK

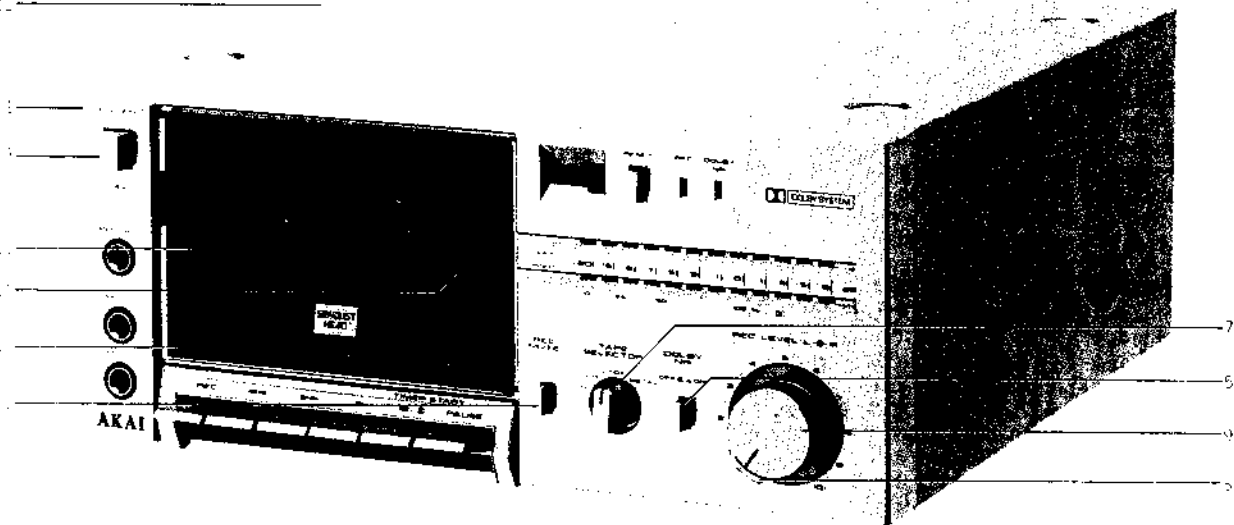

FINAL ASSEMBLY BLOCK

Ref. No.	Parts No.	Description	Schematic No.
10-1	BD705010	Front Panel BLK UC-M2	01 3381-42
10-2x	BD705108	Front Panel BLK UC-M2J	01 3381-42
10-3	SB705110	Push Button UC-M2	62 155-0
10-4x	ZG705112	Button Spring UC-M2	88 154-0
10-5	SB705109	Push Button UC-M2	62 156-0
10-6x	ZG705113	Button Spring UC-M2	88 155-0
10-7	SK705013	Selector Knob UC-M2	62 2219-0
10-8	SK705041	Vol. Knob (Lower) UC-M2	62 2222-0
10-9	SK704998	Vol. Knob (Upper) UC-M2	62 2221-1
10-10	BD705011	Cassette Lid Part UC-M2	01 3381-43
10-11	ZS705111	Lid Screw UC-M2	87 3196-0
10-12	SP705022	Upper Cover UC-M2	71 3061-0

When ordering parts, please quote Parts Number, Description and Model Number.

INDEX

1. MODEL UC-K2

Parts No.	Ref. No. & Symbol No.	Parts No.	Ref. No. & Symbol No.	Parts No.	Ref. No. & Symbol No.	Parts No.	Ref. No. & Symbol No.
BA704848	2-3	EW705098	4-26x				
BA704926	2-1	EW705099	4-23x				
BA704994	2-2	EW705100	4-20				
BD704965	5-1	EZ700844	4-27				
BD705012	5-2x	MI700845	4-38				
BT704872	2-T201	MR704971	4-33				
BT704887	2-T102	SA704973	4-40				
BT704923	4-5x	SB705109	5-7				
BT704924	4-6x	SB705110	5-5				
BT704925	4-3x	SK704915	5-9				
BT704927	4-1	SP704885	4-36				
BT704941	4-2x	SP704914	4-37x				
BT705195	4-4x	SP704974	5-10				
EC244888	2-C122	TA700846	4-49				
EC311778	2-C401	TA704911	5-4x				
EC318378	2-C306,307	TA704964	4-29x				
EC405898	2-C304	TA704966	5-3				
EC704830	2-C108	TA704967	4-31				
EC704831	2-C105	TA704972	4-30				
EC704838	2-C601	ZG704969	4-32x				
EC704883	2-C101	ZG705112	5-6x				
EC704883	2-C103	ZG705113	5-8x				
EC704996	4-16x	ZS200676	5-12x				
EC704997	4-19x	ZS306021	4-47x				
EC704999	4-18x	ZS310344	5-13x				
EC705001	4-17x	ZS316638	4-41x				
ED323530	2-D601	ZS379350	4-15x				
ED324194	2-D204	ZS379405	4-46x				
ED704827	2-D201to203	ZS421806	4-42				
ED704827	2-D205	ZS422076	4-7x				
ED704827	2-D301to303	ZS472274	4-44x				
ED704827	2-D401,402	ZS472274	5-11x				
ED704827	2-D501,502	ZS479474	4-45x				
ED704829	2-D101	ZW231030	4-35				
ED704866	2-D403,404	ZW273745	4-8x				
ED704866	2-D602to606	ZW281463	4-11x				
ED704940	3-D801,802	ZW302896	4-39x				
ED704940	4-50	ZW426587	4-9x				
ED704951	3-D701to706	ZW516993	4-43x				
ED704951	4-48						
EE704875	2-4						
EE704876	2-5						
EE704922	4-28x						
EF704895	2-FU603						
EF704897	2-FU603						
EF704907	2-FU601,602						
EF704909	2-FU601,602						
EF704912	2-FU601,602						
EF704919	2-FU603						
EI213390	2-IC302						
EI213390	2-IC501to503						
EI322248	2-IC202						
EI323247	2-IC401						
EI704824	2-IC201						
EI704828	2-IC101						
EI704835	2-IC301						
EJ704963	4-34						
EL704920	3-LA901to904						
EO704881	2-T103						
ER704826	2-CF201,202						
ER704877	2-T101						
ER704888	2-FL301,302						
ES704871	2-S101to103						
ES704989	4-14x						
ES704990	4-12						
ES704991	4-13x						
ES705007	4-10						
ET306721	2-Q601						
ET307234	2-Q301						
ET307234	2-Q401						
ET704825	2-Q201						
EV704873	2-R210						
EV704873	2-R317						
EV704873	2-R515,516						
EV704884	2-R107						
EV704886	2-R304						
EW704959	4-22x						
EW705002	4-24x						
EW705004	4-25x						
EW705006	4-21x						

INDEX

2. MODEL UC-U2

Parts No.	Ref. No. & Symbol No.	Parts No.	Ref. No. & Symbol No.	Parts No.	Ref. No. & Symbol No.	Parts No.	Ref. No. & Symbol No.
BA705077	2-1	EV705038	6-R252				
BA705078	3-1	EV705050	3-R615				
BD705073	9-1	EV705052	3-R607				
BT705106	8-21x	EV705052	3-R610				
BT705107	8-22x	EV705065	2-R705				
BT705114	8-20x	EW704959	8-29x				
BT705116	8-23x	EW705002	8-31x				
BT705117	8-17	EW705004	8-32x				
BT705118	8-18x	EW705006	8-28x				
BT705119	8-19	EW705098	8-33x				
EC267186	4-C806	EW705099	8-30x				
EC267186	4-C808	EW705100	8-27				
EC322453	7-C903,904	EZ700844	8-34				
EC324665	7-C901,902	MZ705072	8-35x				
EC700831	4-C809	SA704973	8-36				
EC704996	8-5	SB705109	9-4				
EC704997	8-8x	SB705110	9-2				
EC704999	8-7x	SK705013	9-9				
EC705001	8-6x	SK705080	9-6				
EC705040	4-C805	SK705086	9-8				
EC705040	4-C807	SK705087	9-7				
ED237960	7-D901,902	SP705083	8-42x				
ED306723	2-D701	SP705084	8-43x				
ED494627	6-D209	SP705088	8-40x				
ED704829	6-D201,202	SP705089	8-41x				
ED704829	6-D251,252	SP705090	8-38				
ED704951	6-D204to208	SP705091	8-39x				
ED704951	6-D254to258	SP705092	8-44x				
ED704975	7-D903	SP705094	9-10				
ED705039	6-D203	ZG705112	9-5x				
ED705039	6-D253	ZG705113	9-3x				
ED705042	4-D801	ZS202511	8-46				
ED705043	4-D804	ZS321298	8-25				
ED705048	4-D802,803	ZS325495	8-49x				
ED705064	2-D702	ZS413166	8-48x				
ED705127	3-D601	ZS422076	8-4				
EF704894	7-FU901,902	ZS463353	8-15				
EF704895	7-FU903	ZS472274	8-10				
EF704895	7-FU903	ZS472274	8-50x				
EF704907	7-FU901,902	ZS490228	8-24				
EF705024	7-FU901,902	ZS589511	8-45				
EF705028	7-FU903	ZS674537	8-37x				
EF705028	7-FU903	ZW516993	8-47x				
EF705029	2-FU701,702	ZW652408	8-26x				
EF705029	7-FU903						
EF705068	2-FU701,702						
EF705069	2-FU701,702						
EF705069	7-FU903						
EI700753	5-IC501						
EI705035	6-IC201						
EI705035	6-IC251						
EI705051	3-IC601						
EJ704896	8-9						
EJ704899	8-14						
EJ704901	8-13						
EJ705026	8-16						
EJ705070	5-J501						
EL704893	8-12						
EO705067	2-L701						
EP705049	4-RY801						
ER326615	2-R703						
ER449728	7-R901,902						
ER558213	3-R616,617						
ER701012	2-R717						
ER704898	8-11x						
ES704989	8-3x						
ES704990	8-1						
ES704991	8-2x						
ES705031	3-S601						
ES705033	3-S602						
ET293220	2-Q702						
ET293220	2-Q707						
ET293220	4-Q804						
ET293253	2-Q705,706						
ET705046	4-Q801to803						
ET705059	2-Q701						
ET705061	2-Q703						
ET705062	2-Q708						
ET705063	2-Q704						
EV705038	6-R202						

INDEX

3. MODEL UC-M2

Parts No.	Ref. No. & Symbol No.	Parts No.	Ref. No. & Symbol No.	Parts No.	Ref. No. & Symbol No.	Parts No.	Ref. No. & Symbol No.
BA704837	2-1	EJ704953	9-1	MI705138	7-24	ZS674537	9-54
BA704840	3-1	EJ704954	9-2	ML705156	8-1	ZS704995	9-15
BD705010	10-1	EJ704955	9-3	MP704950	7-10	ZS705000	9-43
BD705011	10-10	EJ705008	9-40x	MR704979	9-11	ZS705037	7-20
BD705108	10-2x	EJ705009	9-39	MR705145	7-33	ZS705111	10-11
BF705173	8-22	EO704868	2-L101to104	MV522235	7-18	ZS705178	8-28
BH705023	7-17	EO704868	2-L201to204	MV704945	7-6	ZS705188	7-40
BL705139	7-25	EO704904	3-L501	MZ704978	9-10	ZW231030	9-53
BL705158	8-3	ER311773	2-R123	MZ705140	7-26	ZW281463	9-38
BM705176	8-26	ER311773	2-R223	SA704973	9-41	ZW305546	8-14
BR705164	8-10	ER366028	2-R159,160	SB705109	10-5	ZW321317	8-11
BR705167	8-15	ER416373	3-R511	SB705110	10-3	ZW324417	8-20
BT704983	9-20x	ER496833	2-R161	SK704932	7-45	ZW356657	7-34
BT704984	9-21x	ER704854	2-R131	SK704998	10-9	ZW356657	8-41
BT704985	9-18x	ER704854	2-R231	SK705013	10-7	ZW410051	7-11
BT704986	9-19x	ER704870	2-R187	SK705041	10-8	ZW516993	9-55
BT704987	9-16	ER705032	2-FL101	SP705015	9-48x	ZW621404	8-32
BT704988	9-17x	ER705032	2-FL201	SP705016	9-49x	ZW668621	9-52
BZ705163	8-7	ES704903	2-S101	SP705017	9-50x	ZW704947	7-7
BZ705170	8-19	ES704903	2-S201	SP705018	9-47x	ZW705005	7-23
BZ705174	8-23	ES704905	3-S501	SP705019	9-46x	ZW705005	8-40
BZ705181	8-31	ES704933	5-S401	SP705020	9-44	ZW705187	7-37
EC316182	2-C161	ES704936	5-S402	SP705021	9-45x	ZW705187	8-42
EC316183	2-C142	ES704976	9-7	SP705022	10-12	ZW705190	8-17
EC316183	2-C166	ES704977	9-9	SP705022	10-12	ZW705193	8-12
EC423810	3-C504	ES704989	9-25x	TC705177	8-27		
EC434070	2-C101	ES704990	9-23	TC704839	7-1		
EC434070	2-C201	ES704990	9-23	TC704847	9-56		
EC469708	3-C505	ES704991	9-24x	TC704944	7-4		
EC469708	3-C509	ES705007	9-37	TC704944	8-38		
		ES705151	7-39	TC704958	7-13		
EC646391	2-C107	ES705160	8-5	TC704982	9-13		
EC646391	2-C207	ES705180	8-30	TC705142	7-28		
EC651115	2-C121	ES705192	8-8	TC705143	7-30		
EC651115	2-C221	ET234933	2-Q118,119	TC705144	7-31		
EC704855	2-C104	ET300632	3-Q501,502	TC705153	7-42		
EC704855	2-C204	ET308980	2-Q104	TC705154	7-43		
EC704860	2-C114	ET308980	2-Q108to114	TC705162	8-6		
EC704860	2-C131	ET308980	2-Q204	TC705175	8-25		
EC704860	2-C214	ET308980	2-Q208to214	TC705184	8-34		
EC704860	2-C231	ET309860	2-Q120	ZG704858	7-2		
EC704861	2-C113	ET356984	2-Q117	ZG704859	7-3		
EC704861	2-C213	ET704814	2-Q102,103	ZG704948	7-8		
EC704862	2-C119	ET704814	2-Q202,203	ZG704949	7-9		
EC704862	2-C219	ET704817	2-Q101	ZG704952	7-32		
EC704863	2-C117	ET704817	2-Q201	ZG704960	7-14		
EC704863	2-C217	ET704850	2-Q116	ZG704961	7-15		
EC704864	2-C118	ET704851	2-Q121	ZG704962	7-16		
EC704864	2-C218	ET704852	2-Q105	ZG704980	9-12		
EC704931	3-C503	ET704852	2-Q205	ZG705044	7-21		
EC704996	9-27x	ET704865	2-Q106,107	ZG705112	10-4x		
EC704997	9-28x	ET704865	2-Q115	ZG705113	10-6x		
EC704999	9-30x	ET704865	2-Q206,207	ZG705141	7-27		
EC705001	9-29x	EV704857	2-R120	ZG705146	7-35		
ED322238	2-D112,113	EV704857	2-R137to140	ZG705149	7-38		
ED704827	2-D101to103	EV704857	2-R220	ZG705152	7-41		
ED704827	2-D110	EV704857	2-R237to240	ZG705157	8-2		
ED704827	2-D114,115	EV704928	3-R506	ZG705166	8-13		
ED704827	2-D201	EV704928	3-R510	ZG705168	8-16		
ED704849	2-D108,109	EV704929	3-R503to505	ZG705169	8-18		
ED704866	2-D104to107	EV704929	3-R507to509	ZG705179	8-29		
ED704866	8-43	EV704934	5-R401	ZG705182	8-33		
ED704869	2-D111	EV704938	4-R306	ZG705185	8-35		
ED704940	4-D301to308	EV704938	4-R356	ZG705186	8-36		
ED704940	4-D351to358	EV704939	4-R305	ZS200384	9-57		
ED704940	6-D402	EV704939	4-R355	ZS283454	8-24		
ED704951	4-D309to312	EW705002	9-34x	ZS300506	7-5		
ED704951	4-D359to362	EW705004	9-35x	ZS300506	8-39		
ED704951	6-D401	EW705006	9-32x	ZS303225	7-12		
EF704889	2-FU102	EW705098	9-36x	ZS304806	9-8		
EF704892	2-FU102	EW705099	9-33x	ZS306021	8-37		
EF704894	2-FU102	EW705100	9-31	ZS321194	8-9		
EF704895	2-FU101	EZ631945	9-60x	ZS384131	9-26		
EF704897	2-FU101	EZ700844	9-59	ZS413166	9-6		
EF704900	2-FU101	HE705030	7-19	ZS419872	9-14		
EI306141	2-IC102	HP705045	7-22	ZS463353	9-4		
EI310036	2-IC103	MB705147	7-36	ZS472274	9-58		
EI704853	2-IC101	MB705155	7-44	ZS537074	9-51		
EI704853	2-IC201	MB705159	8-4	ZS563297	9-22		
EI704937	4-IC301	MB705171	8-21	ZS609120	7-29		
EI704937	4-IC351	MC704956	9-5	ZS674537	9-42		

SECTION 5

SCHEMATIC DIAGRAM

1. SCHEMATIC DIAGRAM OF ICs
2. UC-K2 NO. 1601060B SCHEMATIC DIAGRAM
3. UC-U2 NO. 1601059B SCHEMATIC DIAGRAM
4. UC-M2 NO. 1601058B SCHEMATIC DIAGRAM

AN115

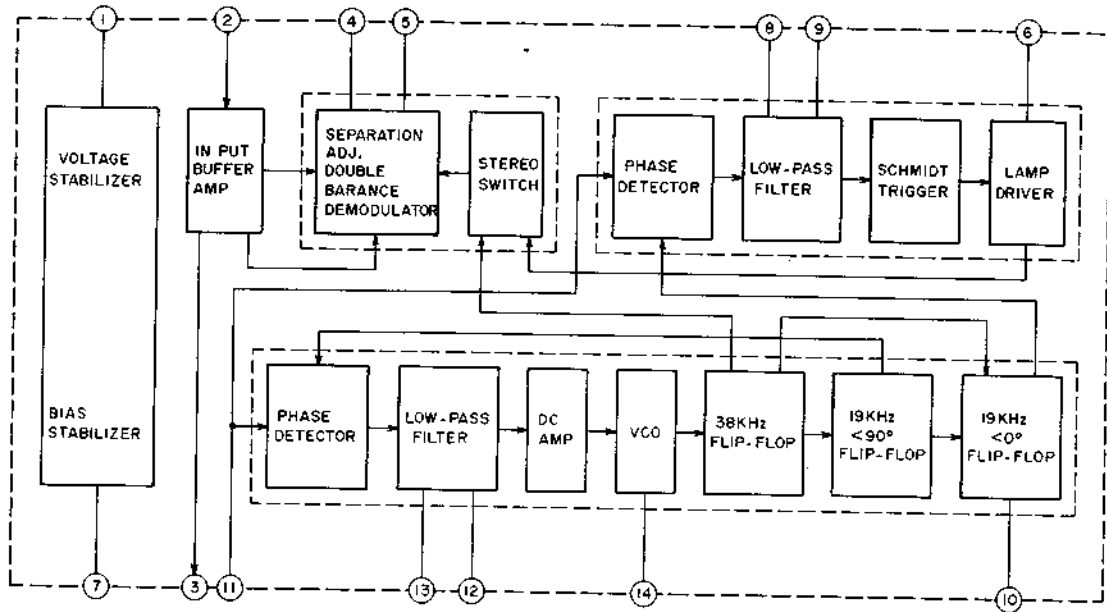

BA-682

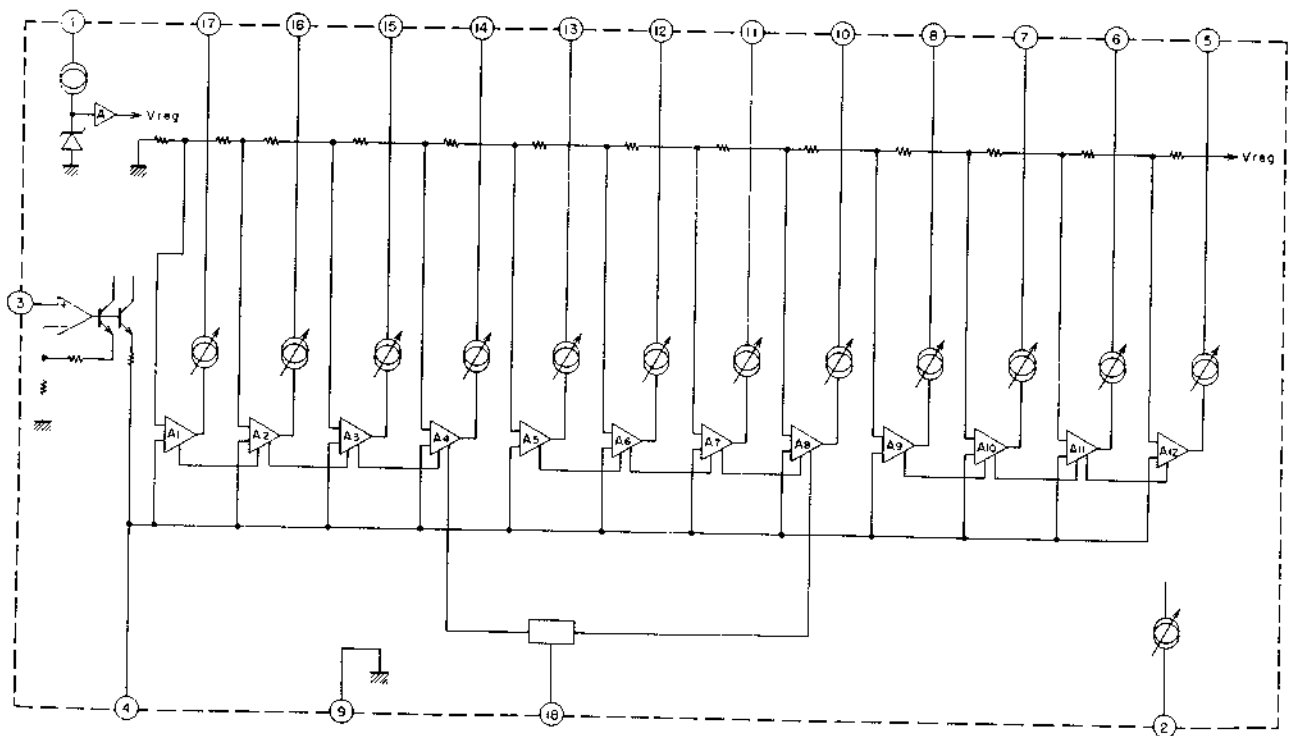

LA1231N

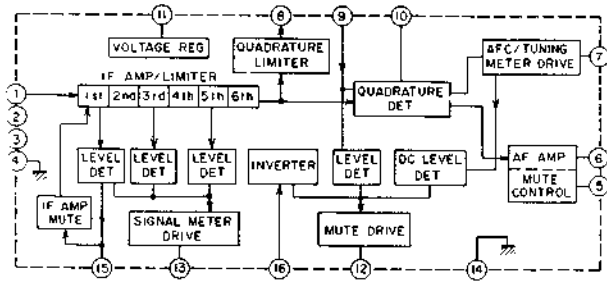

TA7324P

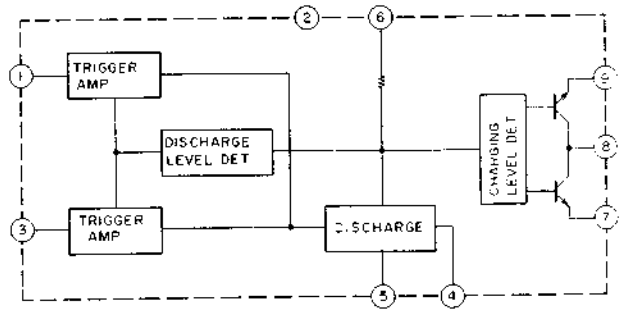

NJM4558D/DA, NJM4559DD

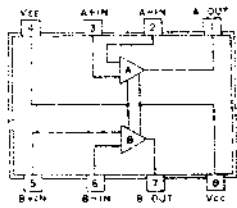

TCA440

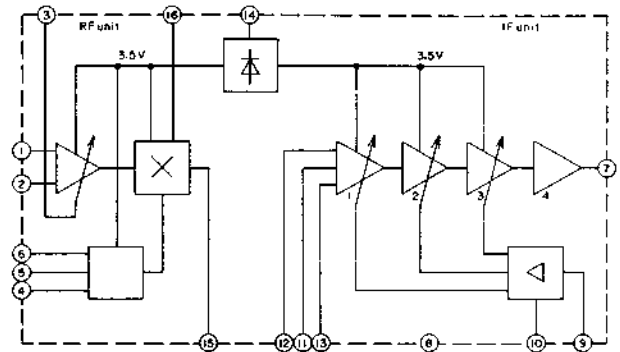

TA-7060AP

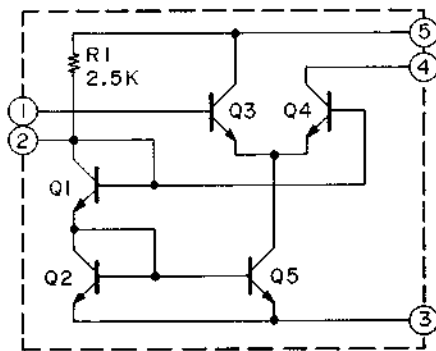

TC-4066BP

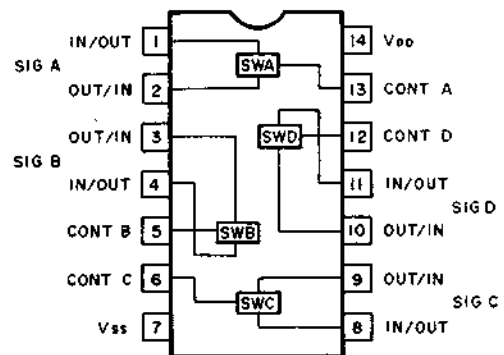

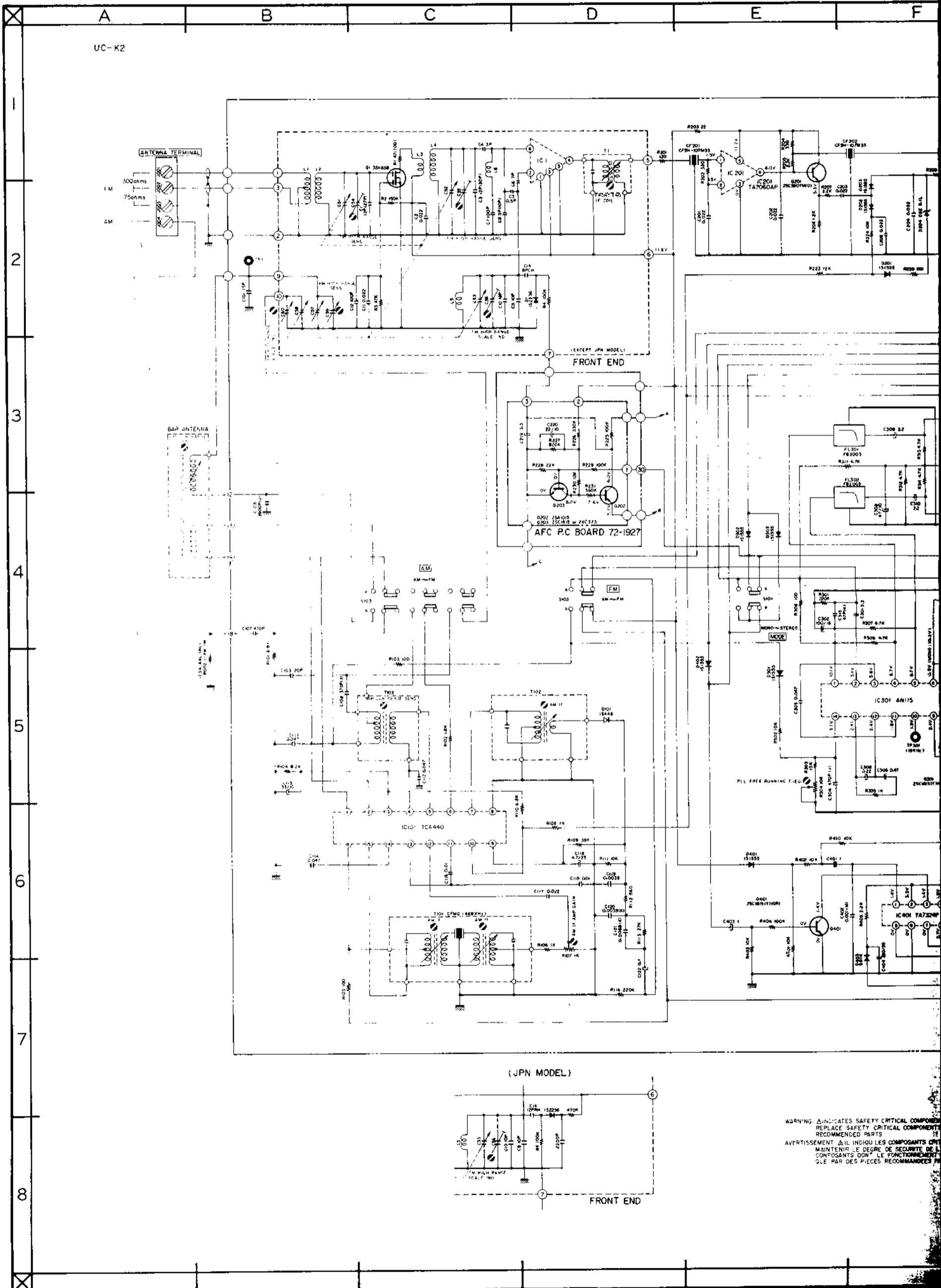

WARNING: Δ INDICATES SAFETY CRITICAL COMPONENTS
 REPLACE SAFETY CRITICAL COMPONENTS WITH RECOMMENDED PARTS
 AVERTISSEMENT: Δ IL INDIQUE LES COMPOSANTS CRITIQUES
 MAINTENIR LE DEGRÉ DE SÉCURITÉ DE LA RADIO EN REEMPLAçant LES
 COMPOSANTS Δ PAR DES PIÈCES RECOMMANDÉES

UC-U2

MAIN AMP P.C BOARD 72-1870 (L ch)

MAIN AMP P.C BOARD 72-1870 (Rch)

EQ AMP P.C BOARD 72-1872

POWER SUPPLY, PROTECTOR

CONTROL, SELECTOR SWITCH P.C BOARD 72-1869

Y	V/T(110/120V) CSA	U/T(120/240V) C/E, UK, SAA	JPN, A
FU901, P02	1200mA	1200mA	0.8T
FU903	T1.6A	7830mA	2C

PRE AMP POWER SUPPLY

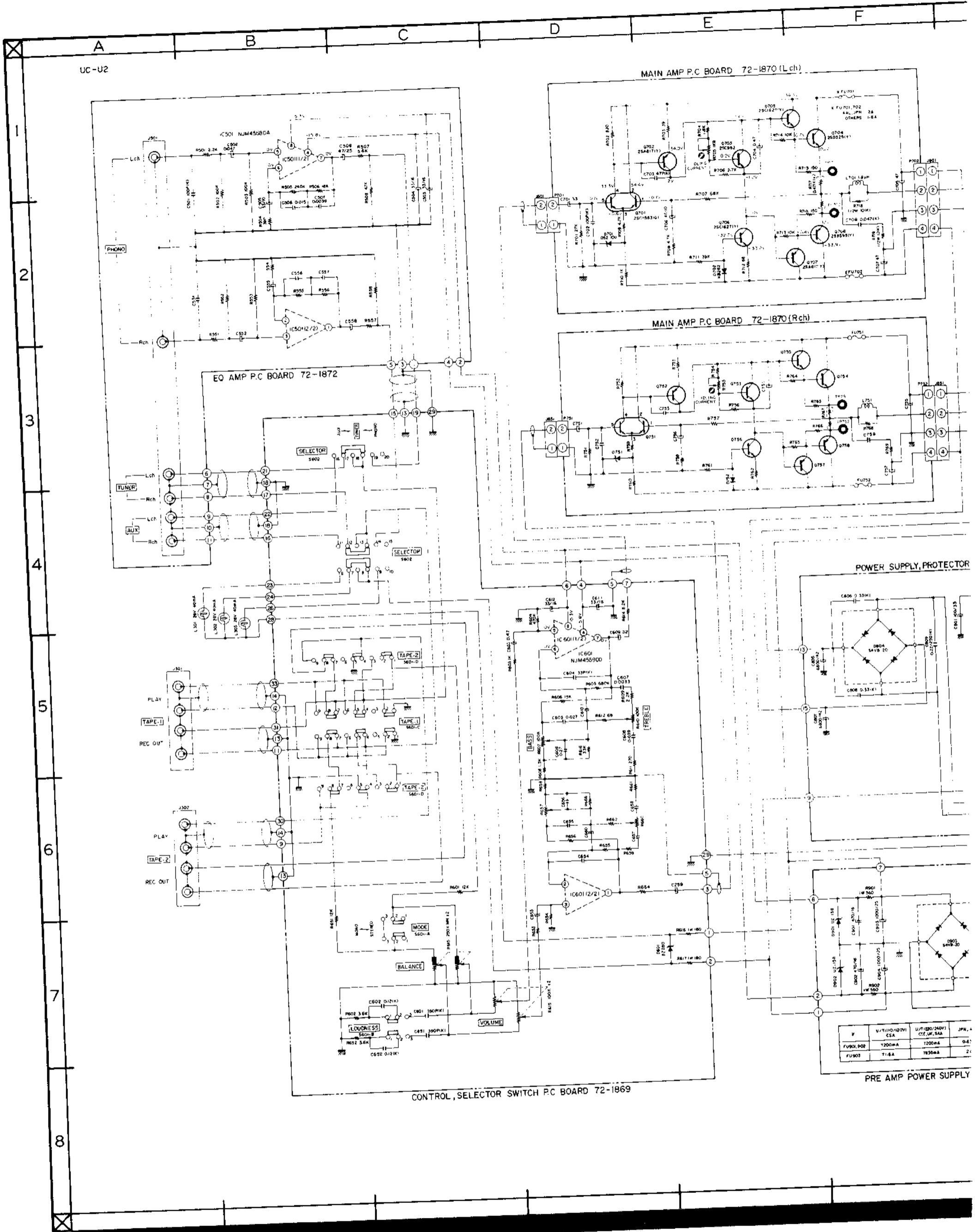

E F G H I J K

BOARD 72-1870 (Lch)

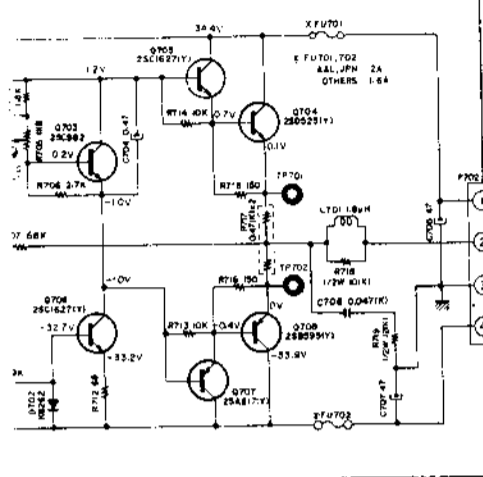

C BOARD 72-1870 (Rch)

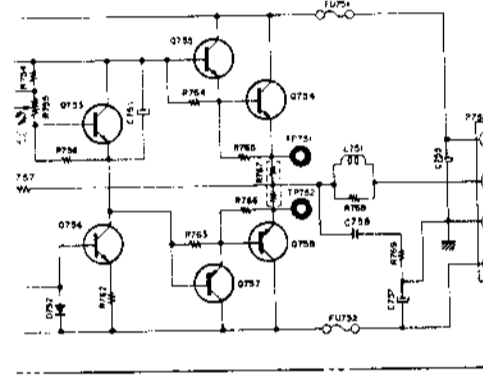

LED DRIVER, DISPLAY P.C BOARD 72-1866

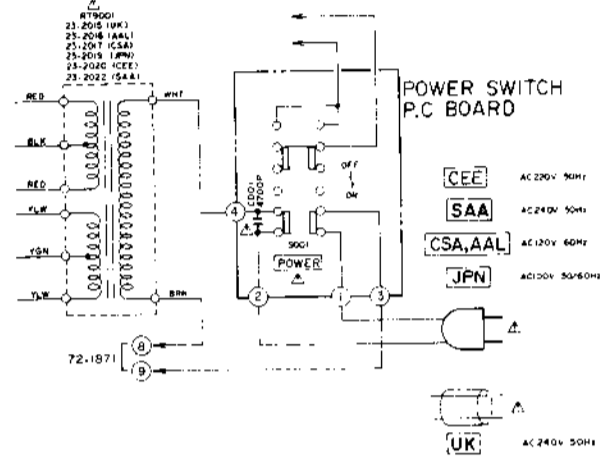
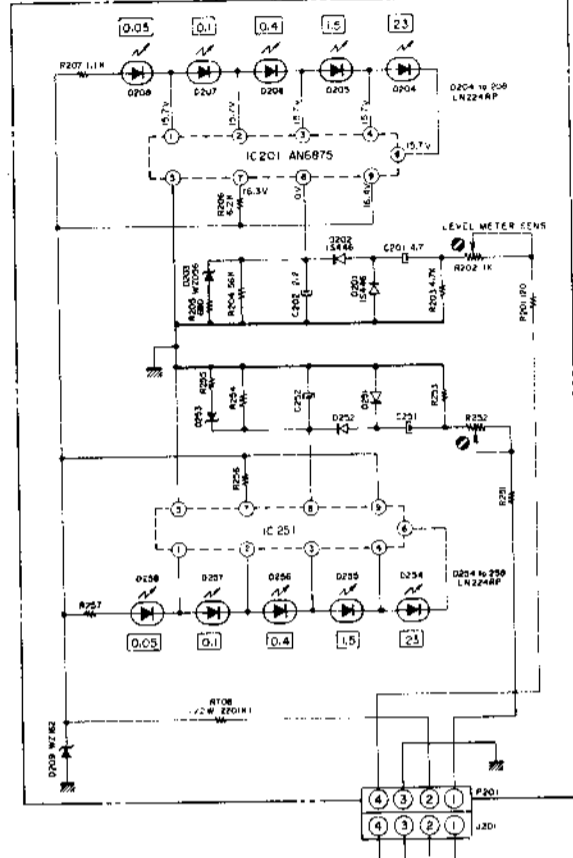

POWER SUPPLY, PROTECTOR P.C BOARD 72-1867

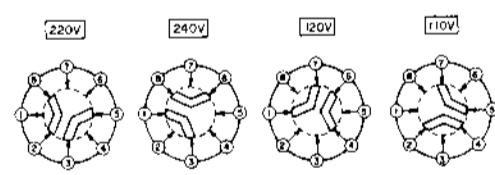
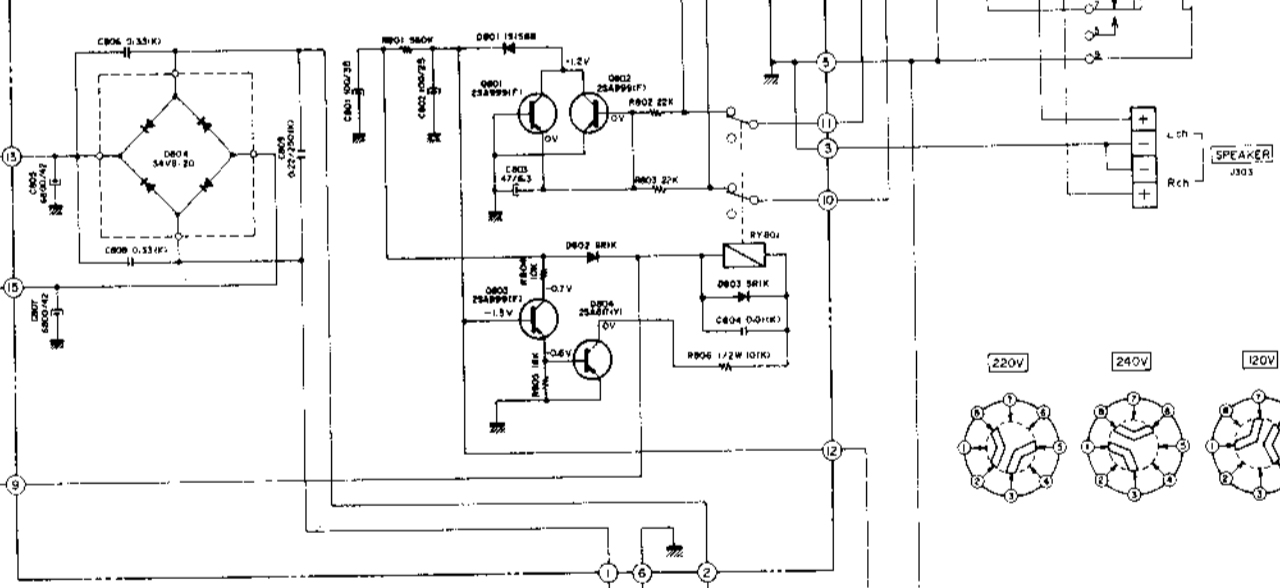

WARNING: Δ INDICATES SAFETY CRITICAL COMPONENTS. FOR CONTINUED SAFETY, REPLACE SAFETY CRITICAL COMPONENTS ONLY WITH MANUFACTURER'S RECOMMENDED PARTS.
 AVERTISSEMENT: Δ IL INDIQUE LES COMPOSANTS CRITIQUES DE SÛRETÉ. POUR MAINTENIR LE DEGRÉ DE SÛRETÉ DE L'APPAREIL, NE REMPLACER LES COMPOSANTS DONT LE FONCTIONNEMENT EST CRITIQUE QUE PAR DES PIÈCES RECOMMANDÉES PAR LE FABRICANT.

POWER SWITCH P.C BOARD 72-1873

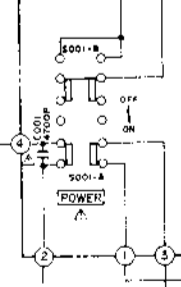

NOTE: UNLESS OTHERWISE SPECIFIED, ALL RESISTORS IN OHMS (1/4W/1/2), ALL CAPACITORS IN μF (50V/100V). POWER TRANSFORMER IS DIFFERENT ACCORDING TO AREA.

U	U17110/120V CSA	U171220/240V CEE, UK, SAA	JPN, AAL
FU901, 902	T200mA	T200mA	0.43A
FU903	T1.6A	T830mA	2A

PRE AMP POWER SUPPLY P.C BOARD 72-1871

UC-U2
 SCHEMATIC DIAGRAM
 NO. 1601059B

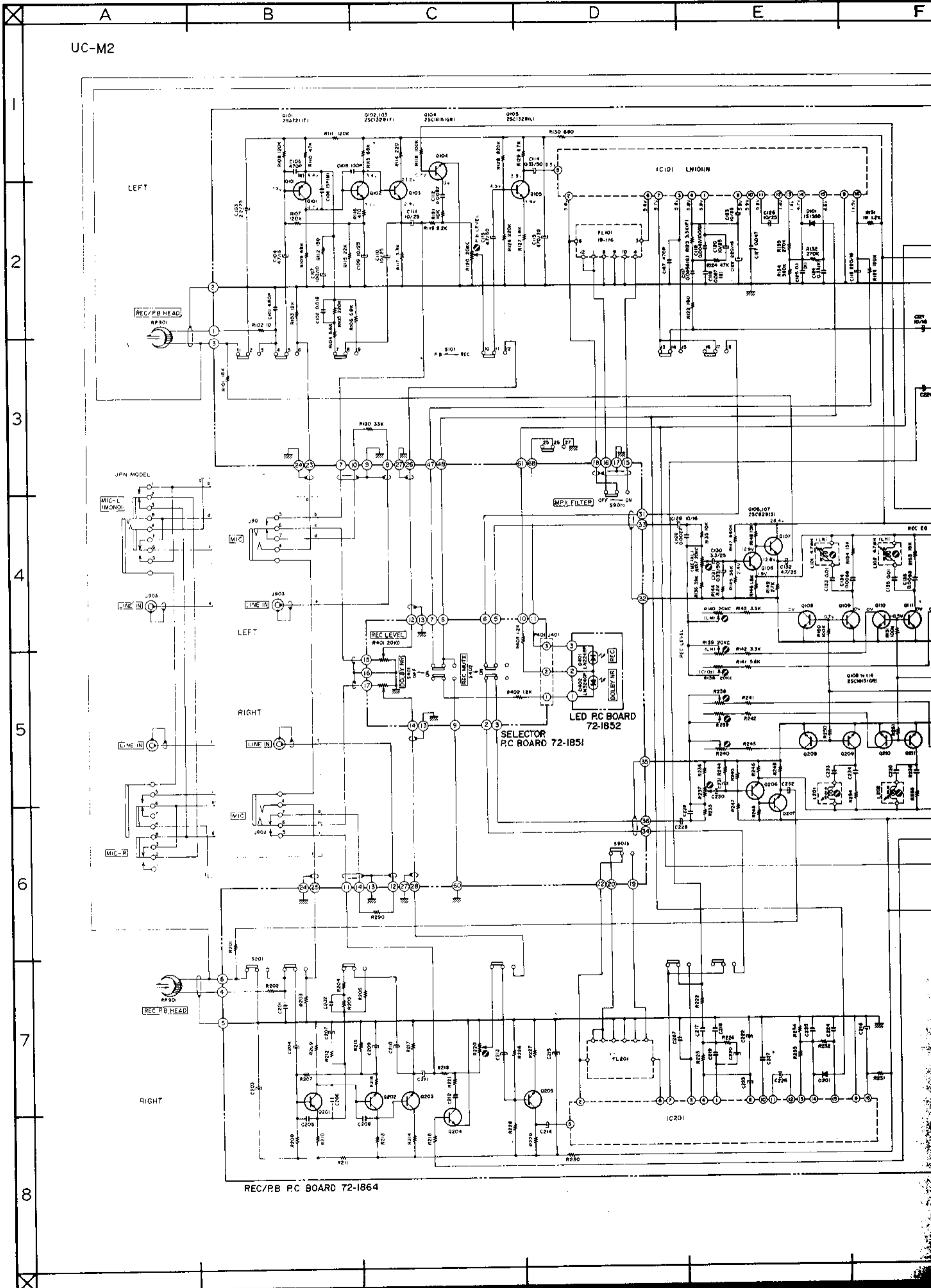

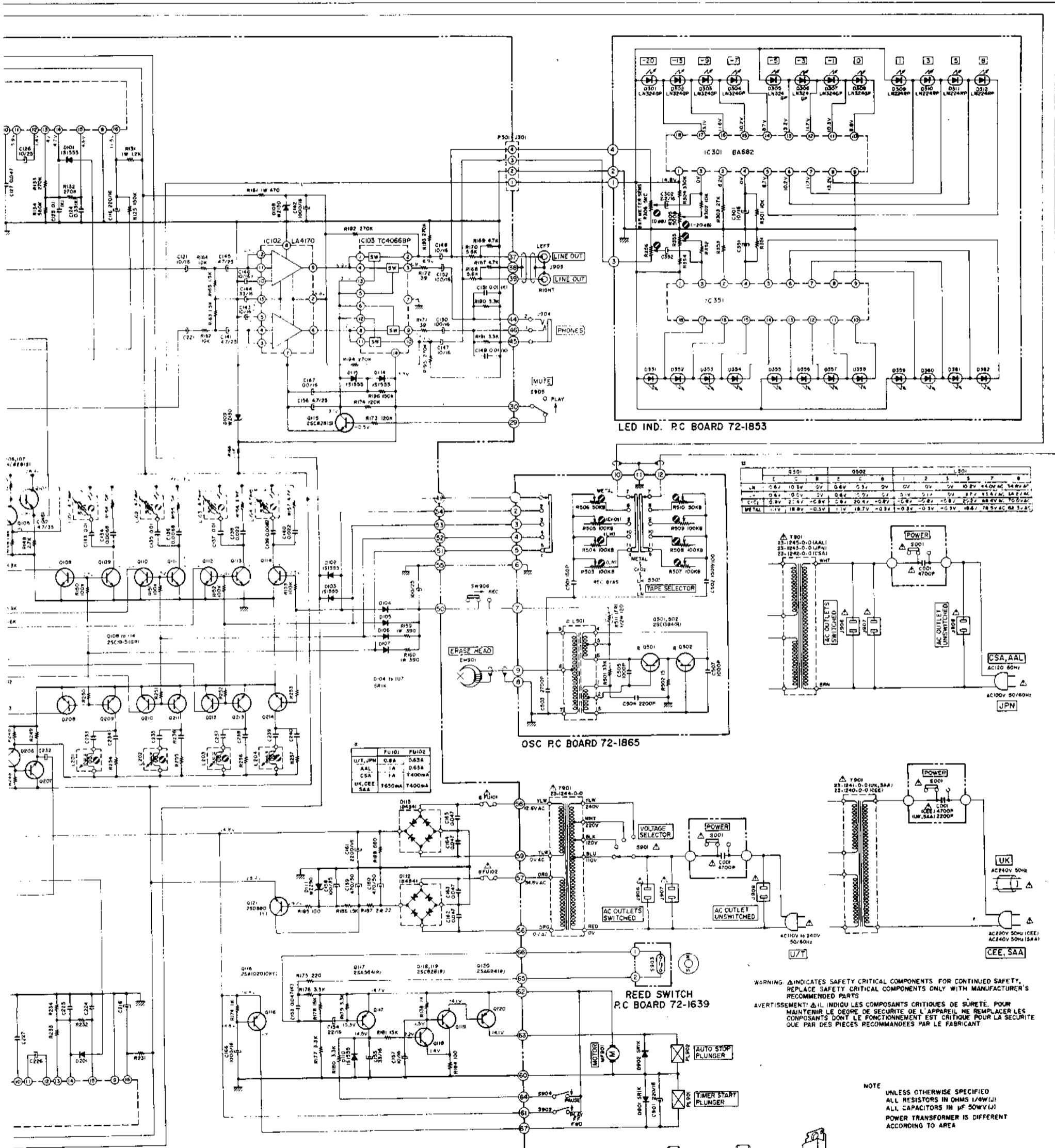

Y 801		Y 802		Y 803	
1	2	3	4	5	6
0.6V	10.5V	2V	0.4V	5.3V	0V
0.6V	0.5V	2V	0.4V	5.3V	0V
0.6V	2.4V	0.8V	20.4V	-0.8V	-0.8V
0.6V	2.4V	0.8V	20.4V	-0.8V	-0.8V
METAL: 1.1V 1.8V -0.5V 1.1V 16.7V -0.3V -0.8V -0.3V -0.5V -0.8V 78.5V AC 6A 3-2-2					

FU101		FU102	
U/T, JPN	0.8A	0.8A	0.8A
AAL	1A	0.63A	0.63A
CSA	1A	T400mA	T400mA
UK, CEE	5A	T650mA	T400mA

WARNING: Δ INDICATES SAFETY CRITICAL COMPONENTS FOR CONTINUED SAFETY. REPLACE SAFETY CRITICAL COMPONENTS ONLY WITH MANUFACTURER'S RECOMMENDED PARTS.
 AVERTISSEMENT: Δ IL INDIQUE LES COMPOSANTS CRITIQUES DE SURETE. POUR MAINTENIR LE DEGRE DE SECURITE DE L'APPAREIL, NE REMPLACER LES COMPOSANTS DONT LE FONCTIONNEMENT EST CRITIQUE POUR LA SECURITE QUE PAR DES PIECES RECOMMANDEES PAR LE FABRICANT.

NOTE
 UNLESS OTHERWISE SPECIFIED
 ALL RESISTORS IN OHMS (Ω/W/L)
 ALL CAPACITORS IN μF (50WV/L)
 POWER TRANSFORMER IS DIFFERENT
 ACCORDING TO AREA



UC-M2
 SCHEMATIC DIAGRAM
 NO. 1601058B