

AKAI SERVICE MANUAL

UC-F5

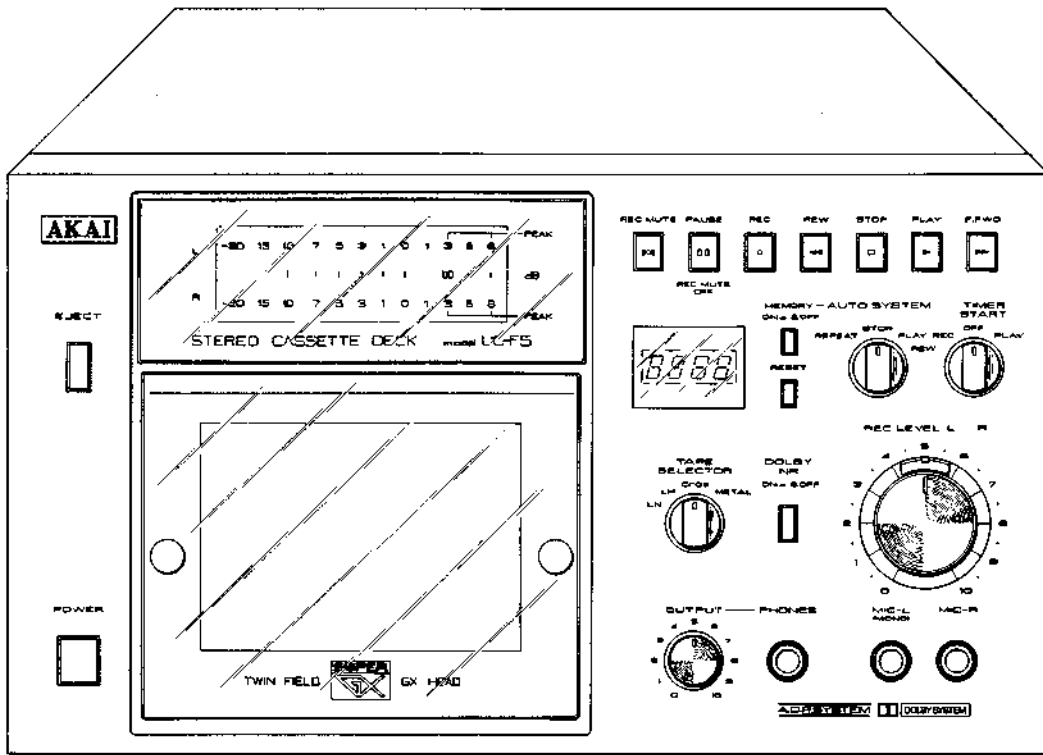

STEREO CASSETTE DECK

MODEL **UC-F5**

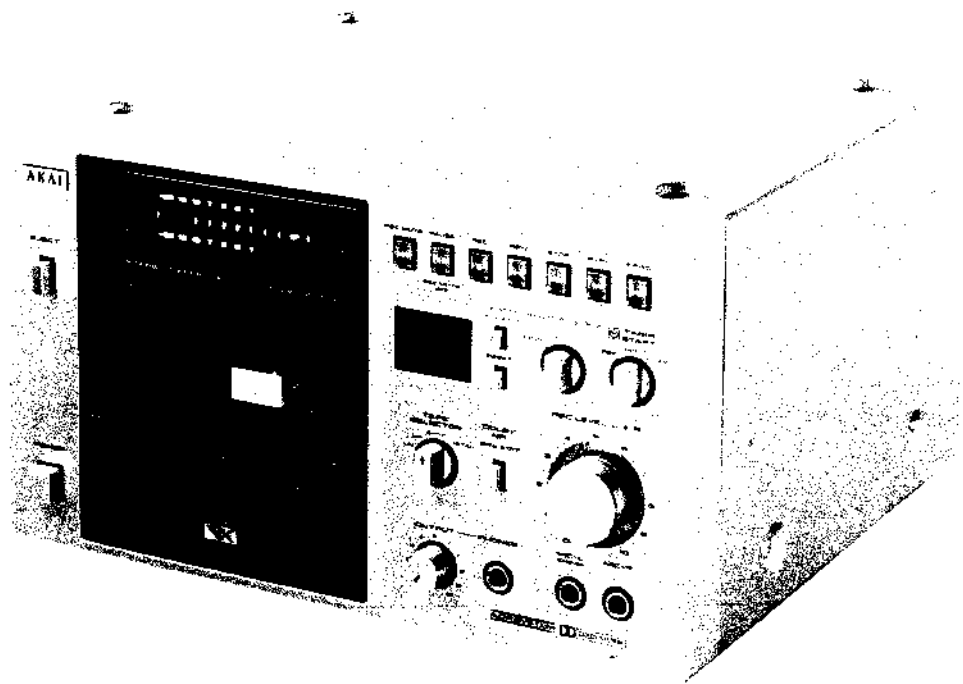

STEREO CASSETTE DECK

MODEL UC-F5

ALSO APPLICABLE TO BLACK PANEL MODEL

SECTION 1	SERVICE MANUAL	3
SECTION 2	PARTS LIST	43
SECTION 3	SCHEMATIC DIAGRAM	61

SECTION 1

SERVICE MANUAL

TABLE OF CONTENTS

I.	TECHNICAL DATA	4
II.	DISMANTLING OF UNIT	5
III.	CONTROLS	7
IV.	PRINCIPAL PARTS LOCATION	8
V.	VOLTAGE AND CYCLE CONVERSION	9
	1. VOLTAGE CONVERSION	9
	2. CYCLE CONVERSION	9
VI.	CIRCUIT OPERATING PRINCIPLES	10
	1. SYSTEM CONTROL OPERATION	10
	2. DIGITAL COUNTER CIRCUITRY OPERATION	19
VII.	MECHANISM ADJUSTMENT	22
	1. PLAY PLUNGER INSTALLATION POSITION ADJUSTMENT	22
	2. PAUSE PLUNGER INSTALLATION POSITION ADJUSTMENT	22
	3. REC SAFETY SWITCH INSTALLATION POSITION ADJUSTMENT	22
	4. TAPE SPEED ADJUSTMENT	22
	5. BRAKE PLUNGER INSTALLATION POSITION ADJUSTMENT	23
	6. FLYWHEEL LOOSE PLAY ADJUSTMENT	23
	7. PINCH ROLLER PRESSURE MEASUREMENT	24
	8. WINDING TORQUE MEASUREMENT IN EACH MODE	24
	9. ADJUSTMENT OF DIGITAL COUNTER'S SENSITIVITY	25
VIII.	HEAD ADJUSTMENT	26
	1. TAPE GUIDE HEIGHT ADJUSTMENT	26
	2. REC/PB HEAD PROJECTION ADJUSTMENT	26
	3. RECORDING/PLAYBACK HEAD HEIGHT ADJUSTMENT	27
	4. RECORDING/PLAYBACK HEAD AZIMUTH ALIGNMENT ADJUSTMENT	27
IX.	AMPLIFIER ADJUSTMENT	28
X.	DC RESISTANCE OF VARIOUS COILS	31
XI.	CLASSIFICATION OF VARIOUS P.C BOARDS	32
	1. P.C BOARD TITLES AND IDENTIFICATION NUMBERS	32
	2. COMPOSITION OF VARIOUS P.C BOARDS	33

For basic adjustments, measuring methods, and operating principles, refer to GENERAL TECHNICAL MANUAL.

I. TECHNICAL DATA

TRACK SYSTEM	4 track 2 channel stereo system
TAPE	Philips type cassette
TAPE SPEED	4.76 cm/s $\pm 1.5\%$ (1-7/8 ips. $\pm 1.5\%$)
HEADS	Erase head x1 Twin field super GX recording/playback head x1
MOTORS	Electronically speed controlled DC motor for capstan drive x1 DC motor for reel drive x1
WOW & FLUTTER	Less than 0.035% WRMS, 0.10% (DIN 45500)
TAPE WINDING TIME	60 sec. using a C-60 cassette tape
FREQUENCY RESPONSE	LN: 30 to 15,000 Hz ± 3 dB (-20 VU) LH: 30 to 16,000 Hz ± 3 dB (-20 VU) CrO ₂ : 30 to 16,500 Hz ± 3 dB (-20 VU) 30 to 9,000 Hz ± 3 dB (0 VU) Metal: 30 to 19,000 Hz ± 3 dB (-20 VU) 30 to 13,000 Hz ± 3 dB (0 VU)
SIGNAL TO NOISE RATIO	LN: Better than 58 dB LH: Better than 59 dB CrO ₂ : Better than 60 dB Metal: Better than 61 dB (measured via tape with peak recording level) Dolby NR switch ON: Improves up to 10 dB above 5 kHz
HARMONIC DISTORTION	LN: Less than 0.8% LH: Less than 0.8% CrO ₂ : Less than 0.7% Metal: Less than 0.6%
INPUT	MIC 0.25 mV (input impedance 5.0 kohms) Required microphone impedance: 600 ohms LINE: 70 mV (input impedance 47 kohms)
OUTPUT	LINE: 410 mV at 0 VU Required load impedance: more than 100 kohms PHONE: 100 mV/8 ohms at 0 VU
DIMENSIONS	280 (W) x 161 (H) x 277 (D) mm (11.0 x 6.3 x 10.9")
WEIGHT	7.6 kg (16.7 lbs)
POWER REQUIREMENTS	100 V, 50/60 Hz for Japan Model 120 V, 60 Hz for U.S.A. and Canada 220/240 V, switchable 50 Hz for European countries and Australia 110/120/220/240 V, 50/60 Hz switchable for other countries
POWER CONSUMPTION	28 W for JPN Model 30 W for the other Models

* For improvement purposes, specifications and design are subject to change without notice.

* "Dolby" and the Double D symbol are trademarks of Dolby Laboratories. (Manufactured under license from Dolby Laboratories).

II. DISMANTLING OF UNIT

In case of trouble, etc. necessitating dismantling, please dismantle in the order shown in the photographs. Reassemble in reverse order.

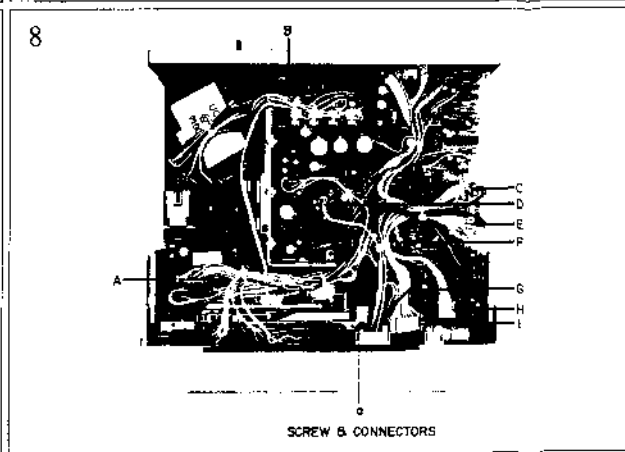
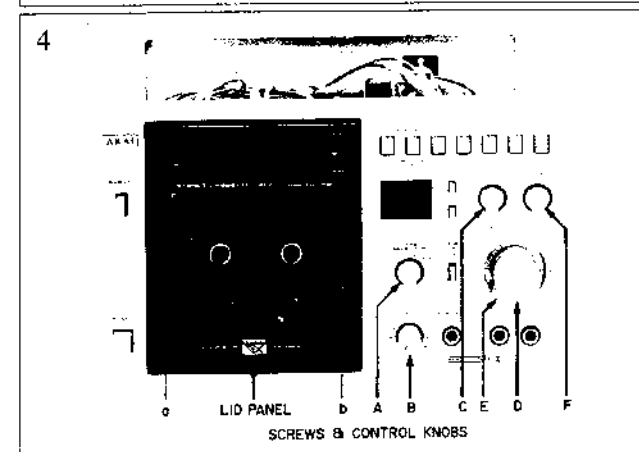
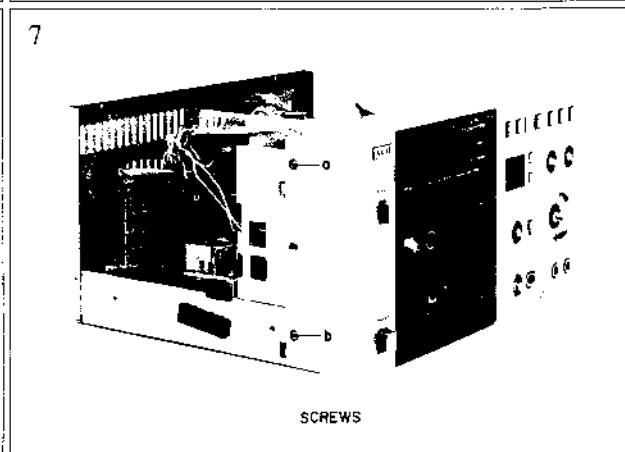
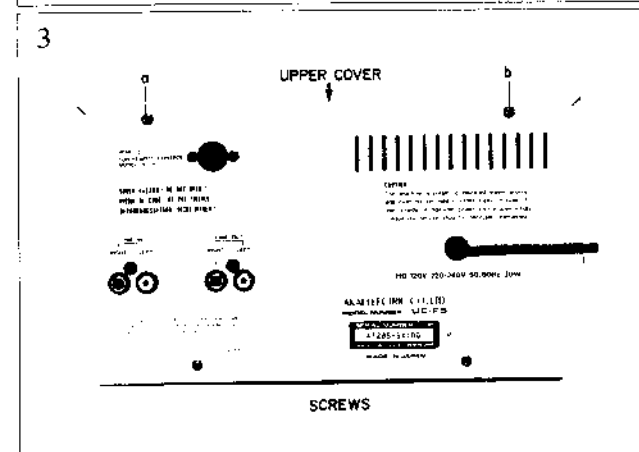
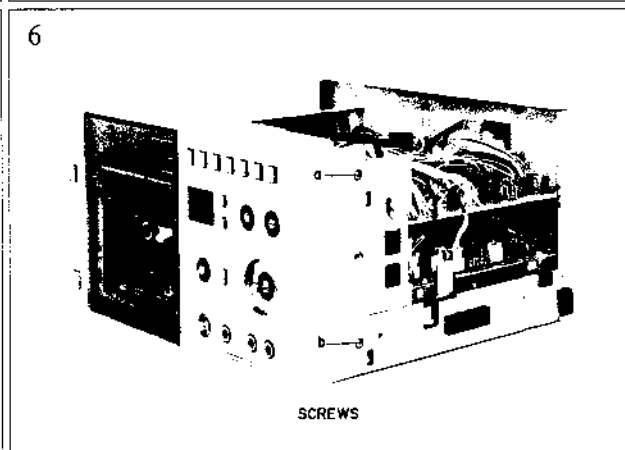
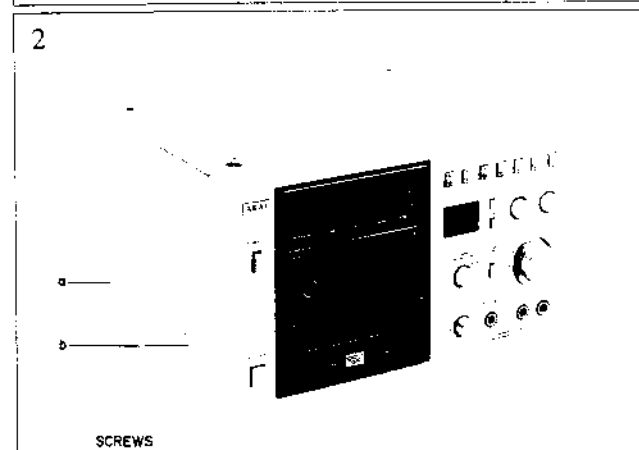
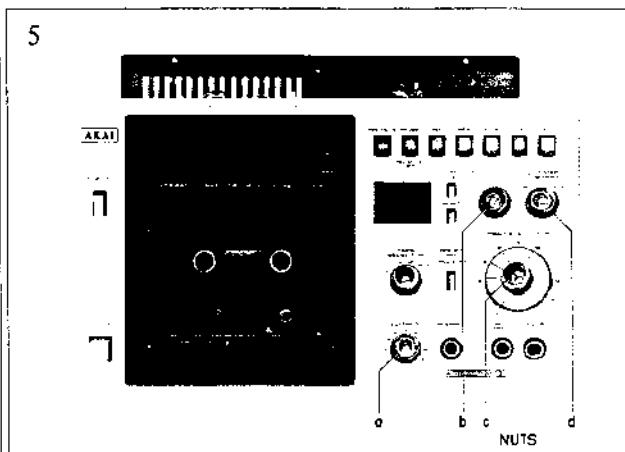
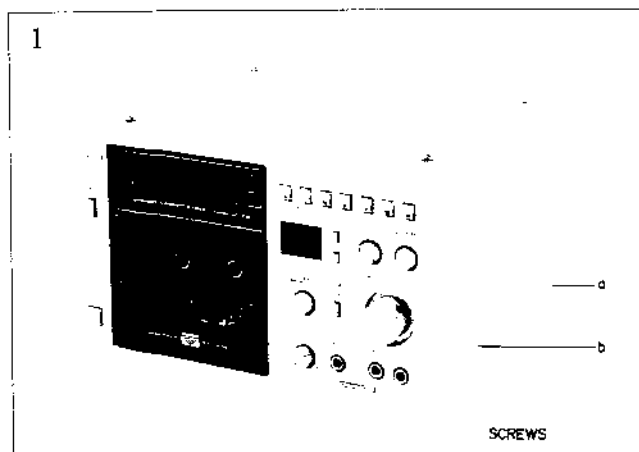

9

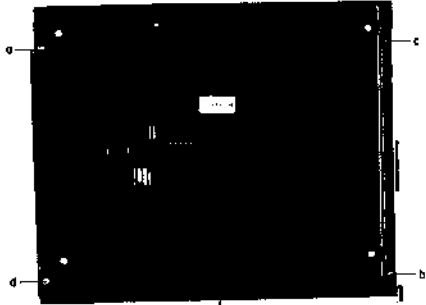

BOTTOM PLATE SCREWS

12

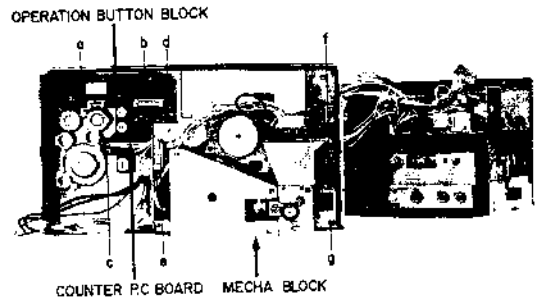

10

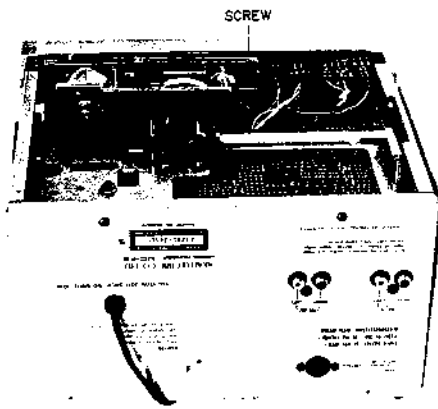

13 Connect each connector.

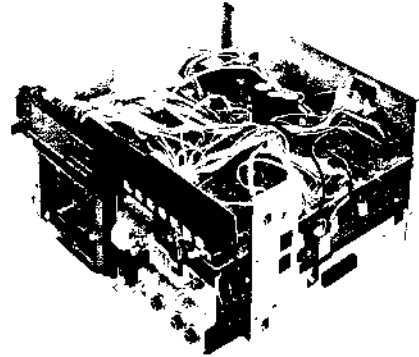

11

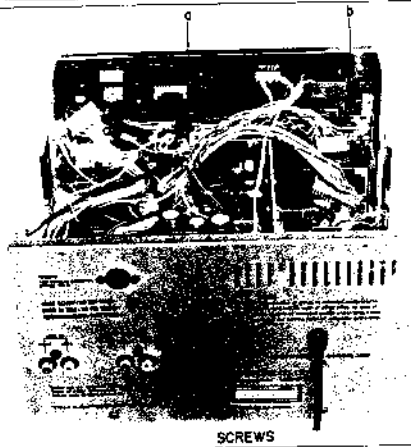

III. CONTROLS

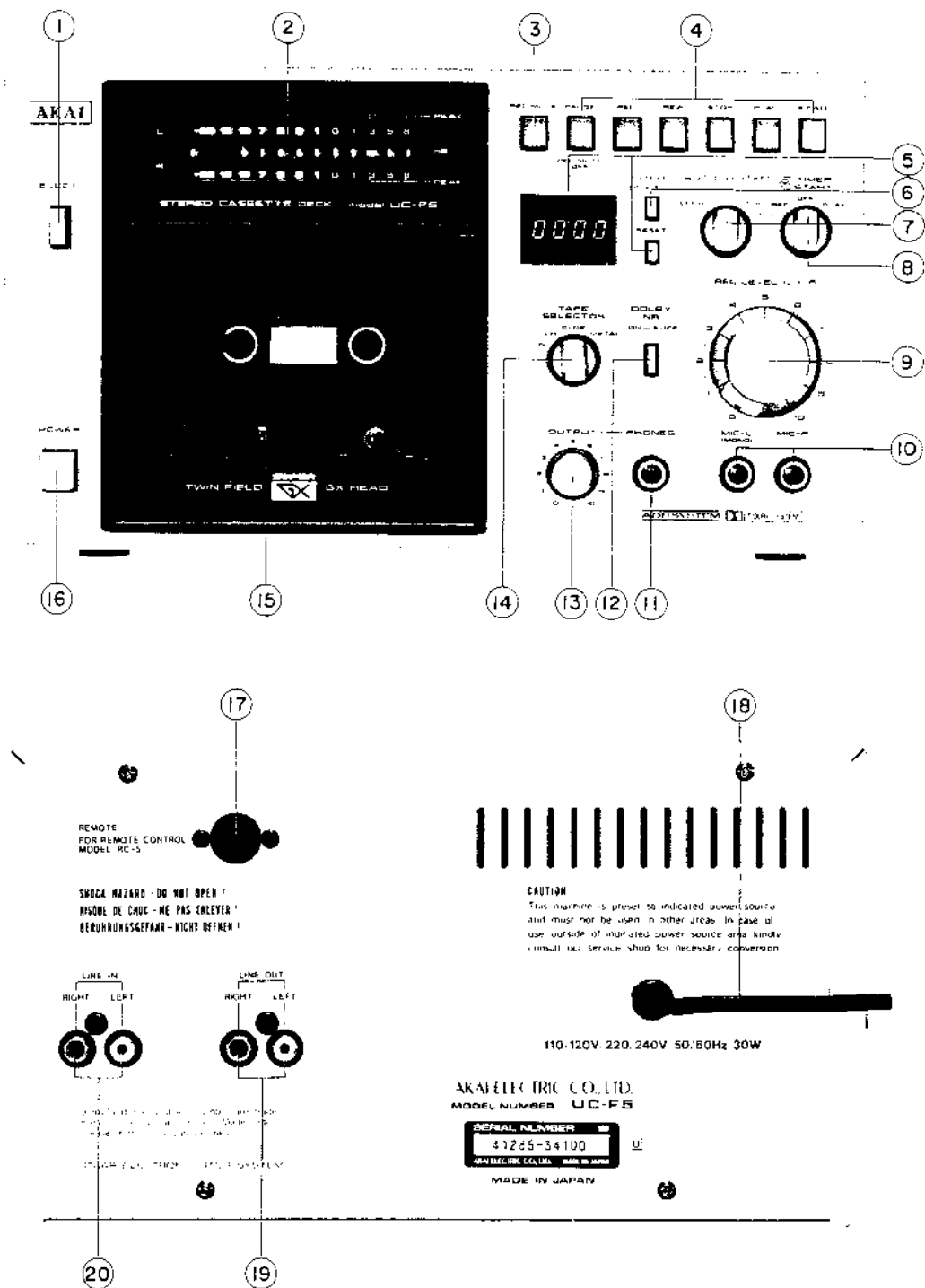

Fig. 1 Controls

- | | |
|--|-------------------------------|
| 1. EJECT BUTTON | 12. DOLBY NR BUTTON |
| 2. FL DISPLAY BAR METERS | 13. OUTPUT LEVEL CONTROL |
| 3. REC MUTE | 14. TAPE SELECTOR |
| 4. MODE BUTTONS | 15. CASSETTE RECEPTACLE |
| 5. INDEX COUNTER and RESET BUTTON | 16. POWER SWITCH |
| 6. MEMORY BUTTON | 17. REMOTE CONTROL JACK |
| 7. AUTO SYSTEM | 18. POWER CORD |
| 8. TIMER START SWITCH | (Some units have an AC inlet) |
| 9. REC LEVEL CONTROLS (Left and Right) | 19. LINE OUT JACKS |
| 10. MICROPHONE JACKS (Left and Right) | 20. LINE IN JACKS |
| 11. HEADPHONE JACK | |

IV. PRINCIPAL PARTS LOCATION

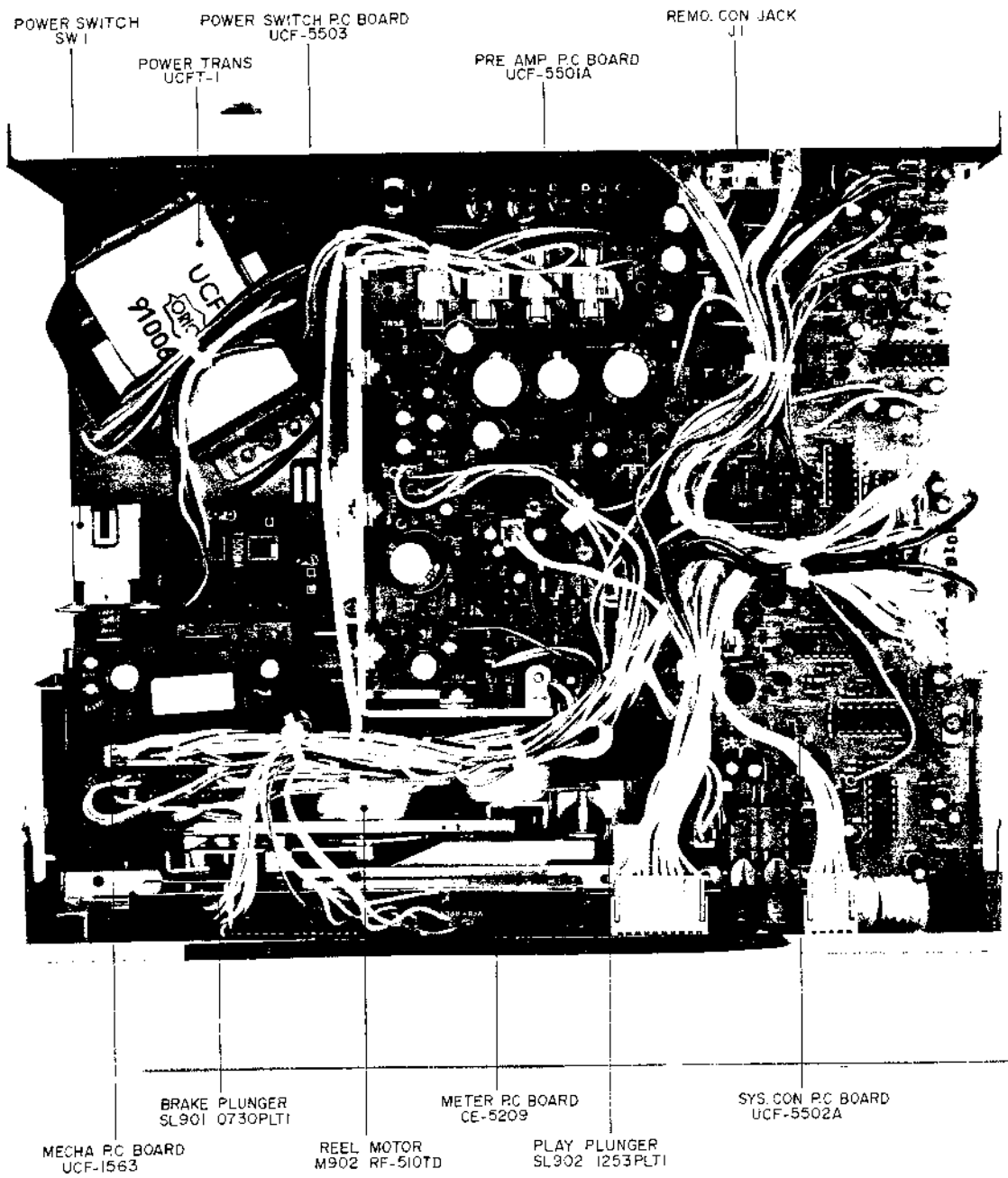

Fig. 2 Top View

V. VOLTAGE AND CYCLE CONVERSION

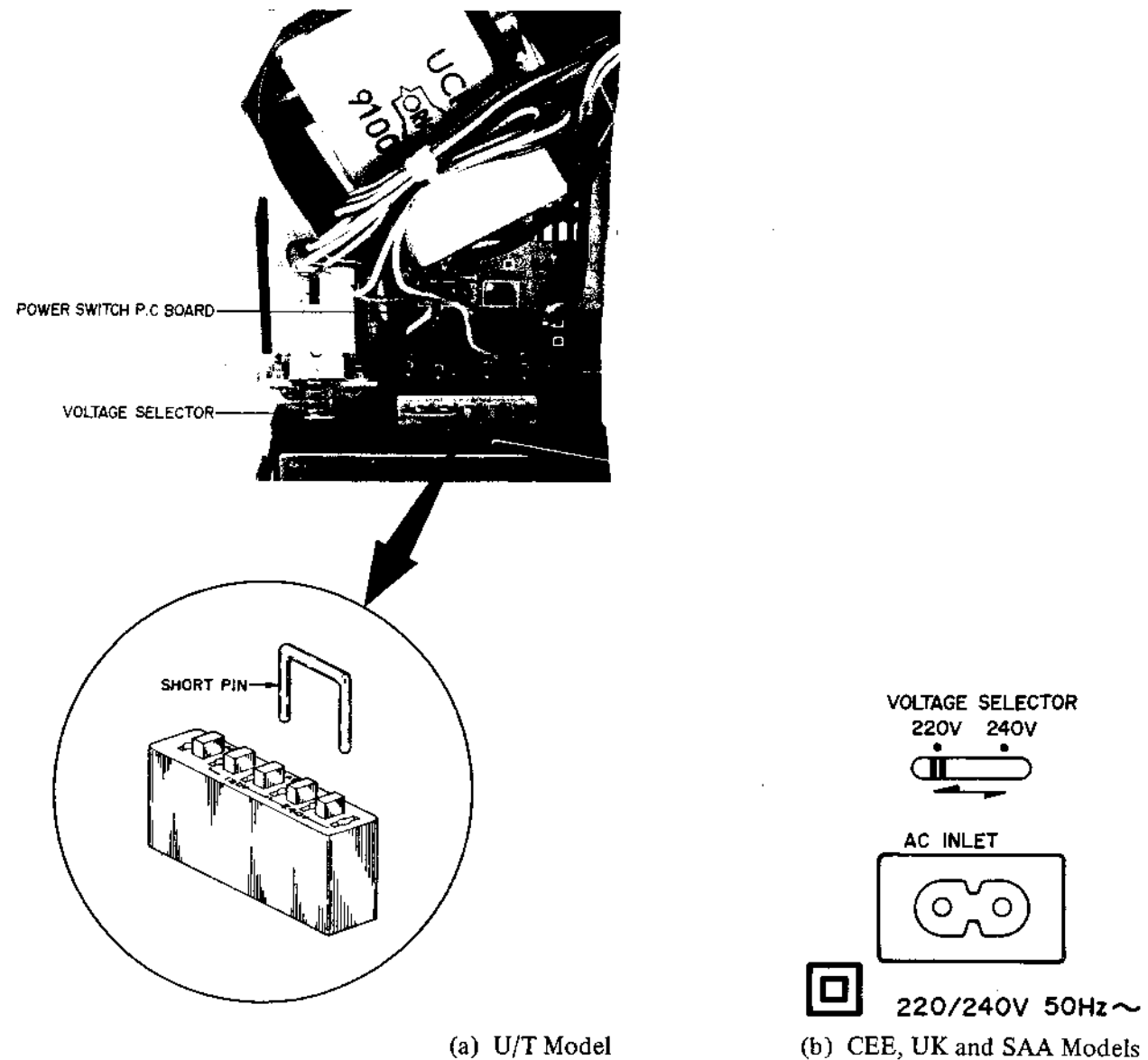

Fig. 3 Voltage Conversion

1. VOLTAGE CONVERSION

1-1. JPN, CSA and AAL Models

No, voltage conversion.

1-2. U/T Model (Refer to Fig. 3(a))

- 1) Disconnect power cord.
- 2) Loosen holding screws and remove upper cover.
- 3) Remove short pin plug from present holes and replace in correct holes. Follow the markings explicitly.

1-3. CEE, UK and SAA Models (Refer to Fig. 3(b))

A voltage selector switch is provided above the AC inlet on the back side of machine. Select the proper voltage by this switch according to the voltage to be used. Move the switch to the left side for 220V and to the right side for 240V.

2. CYCLE CONVERSION

With DC motor, cycle conversion is not necessary.

VI. CIRCUIT OPERATING PRINCIPLES

1. SYSTEM CONTROL OPERATION

Schematic - 1 STOP MODE

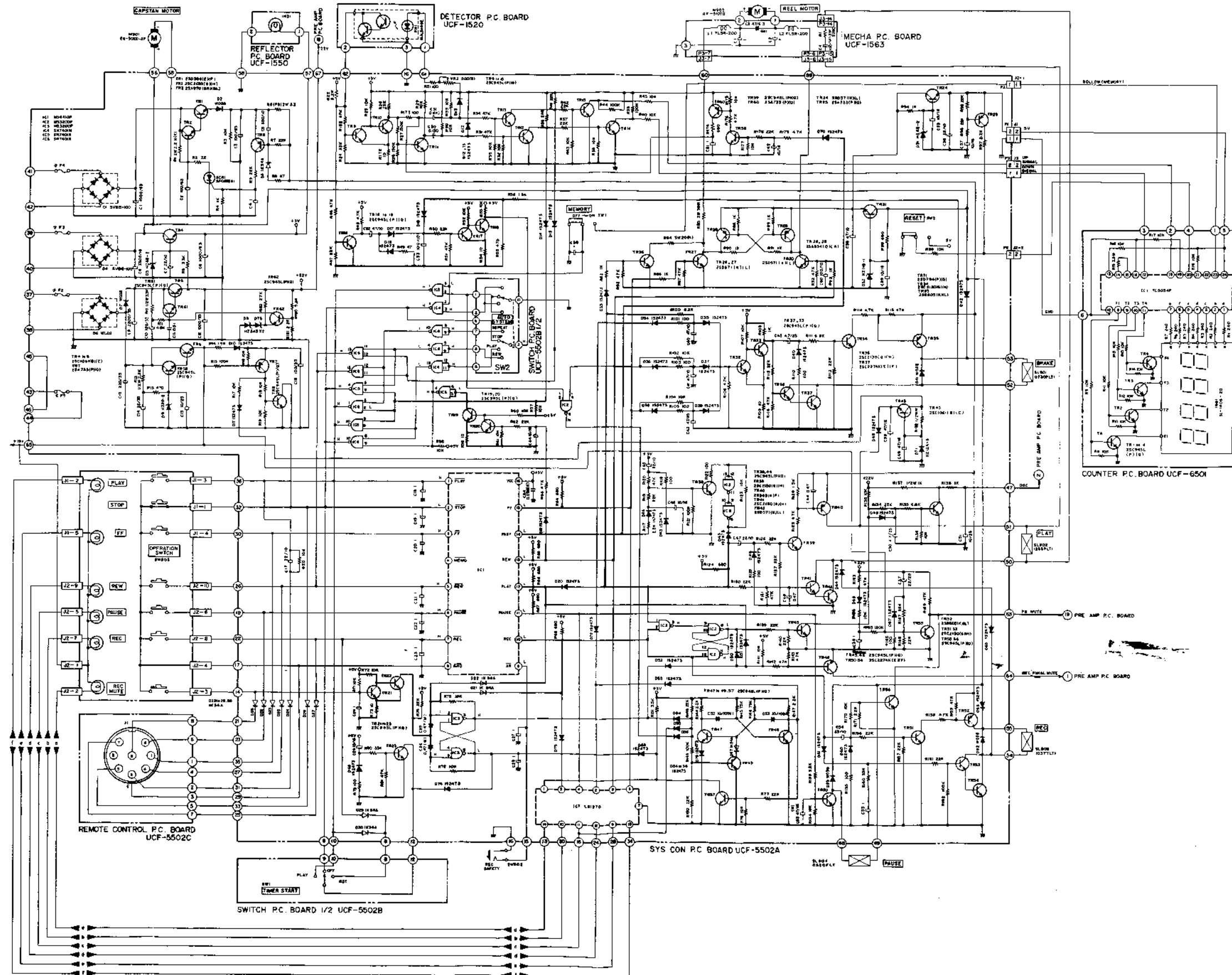

Schematic - 2 PLAY MODE

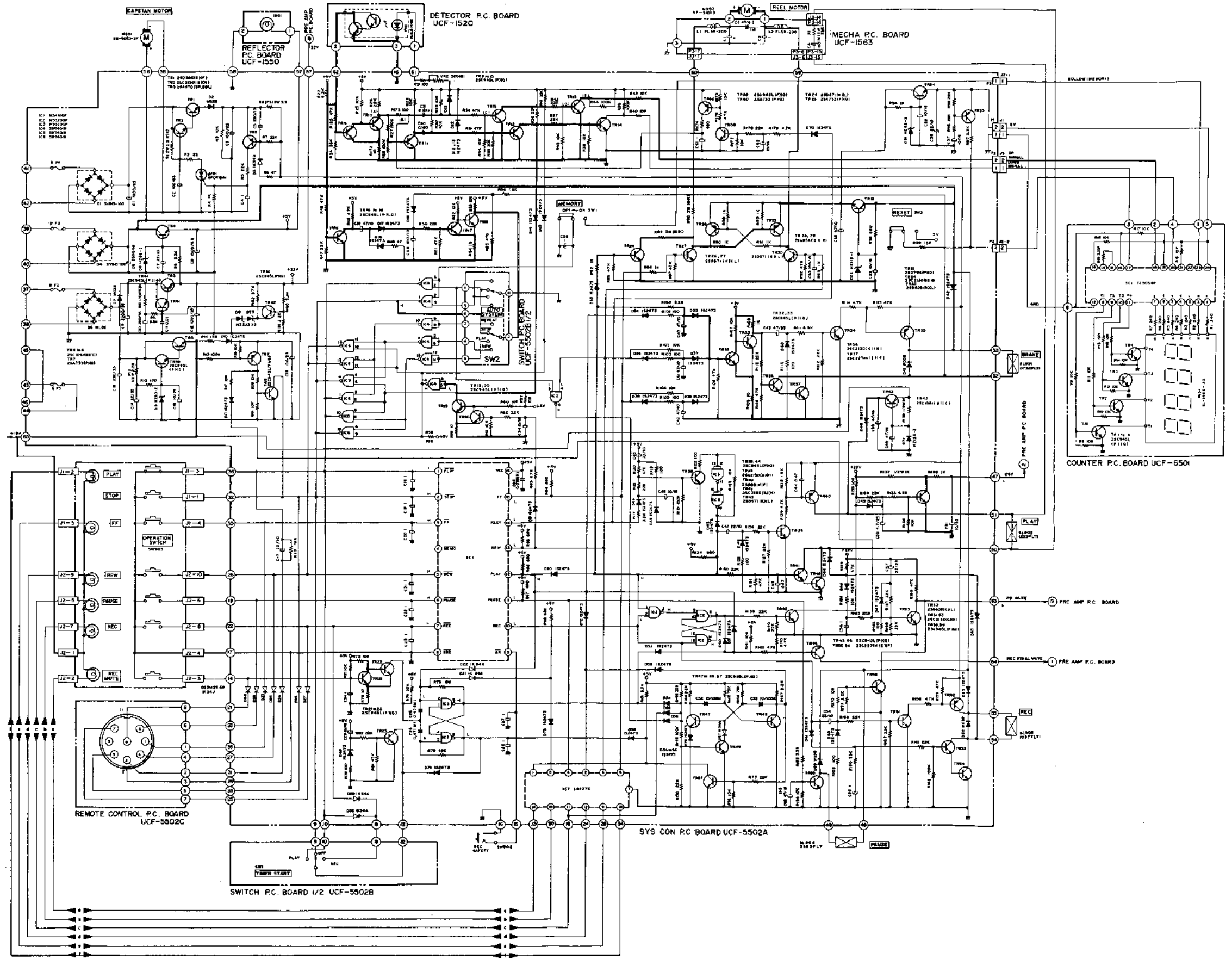

Schematic - 3 REC/PLAY MODE

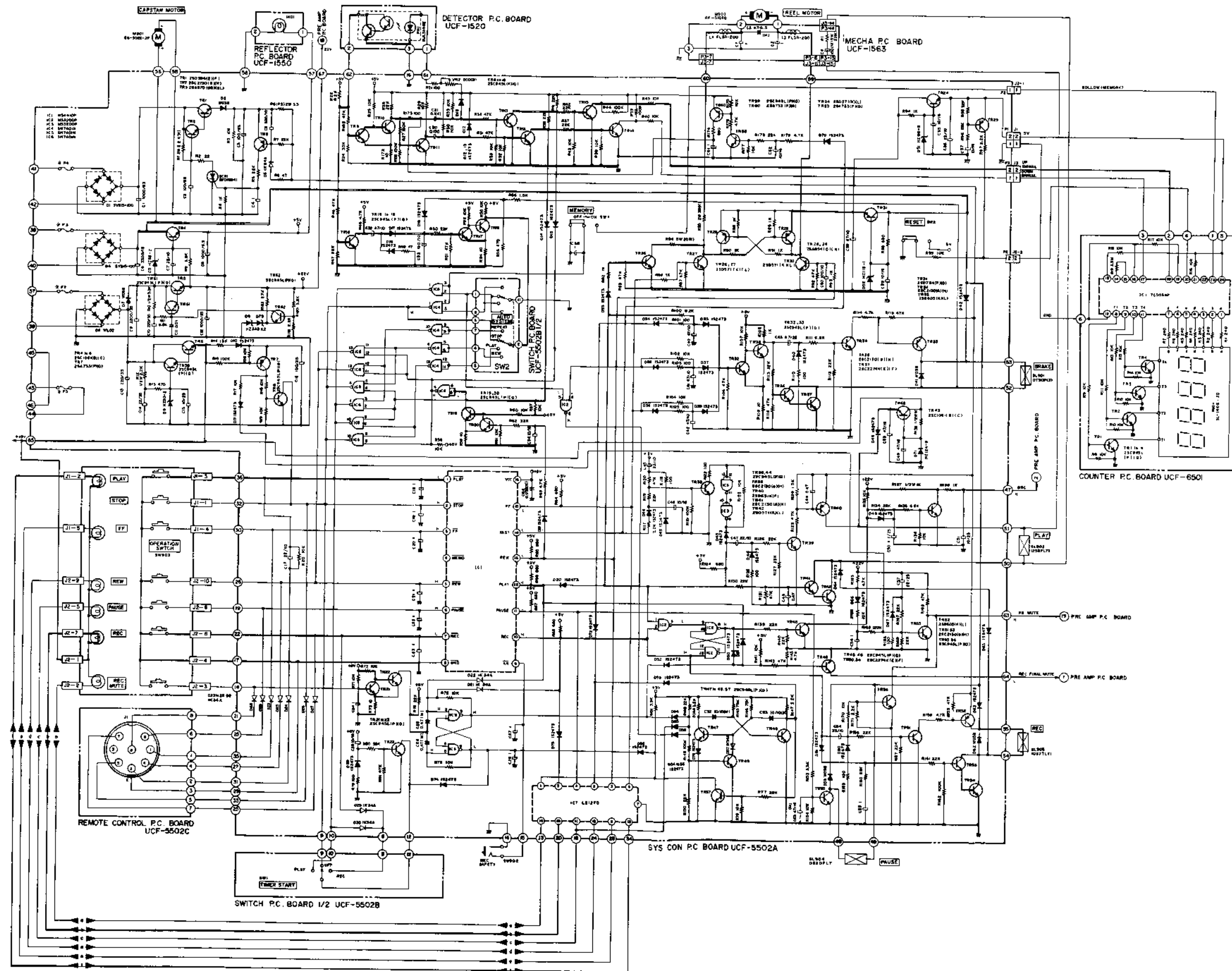

Schematic - 4 REC/PAUSE MODE

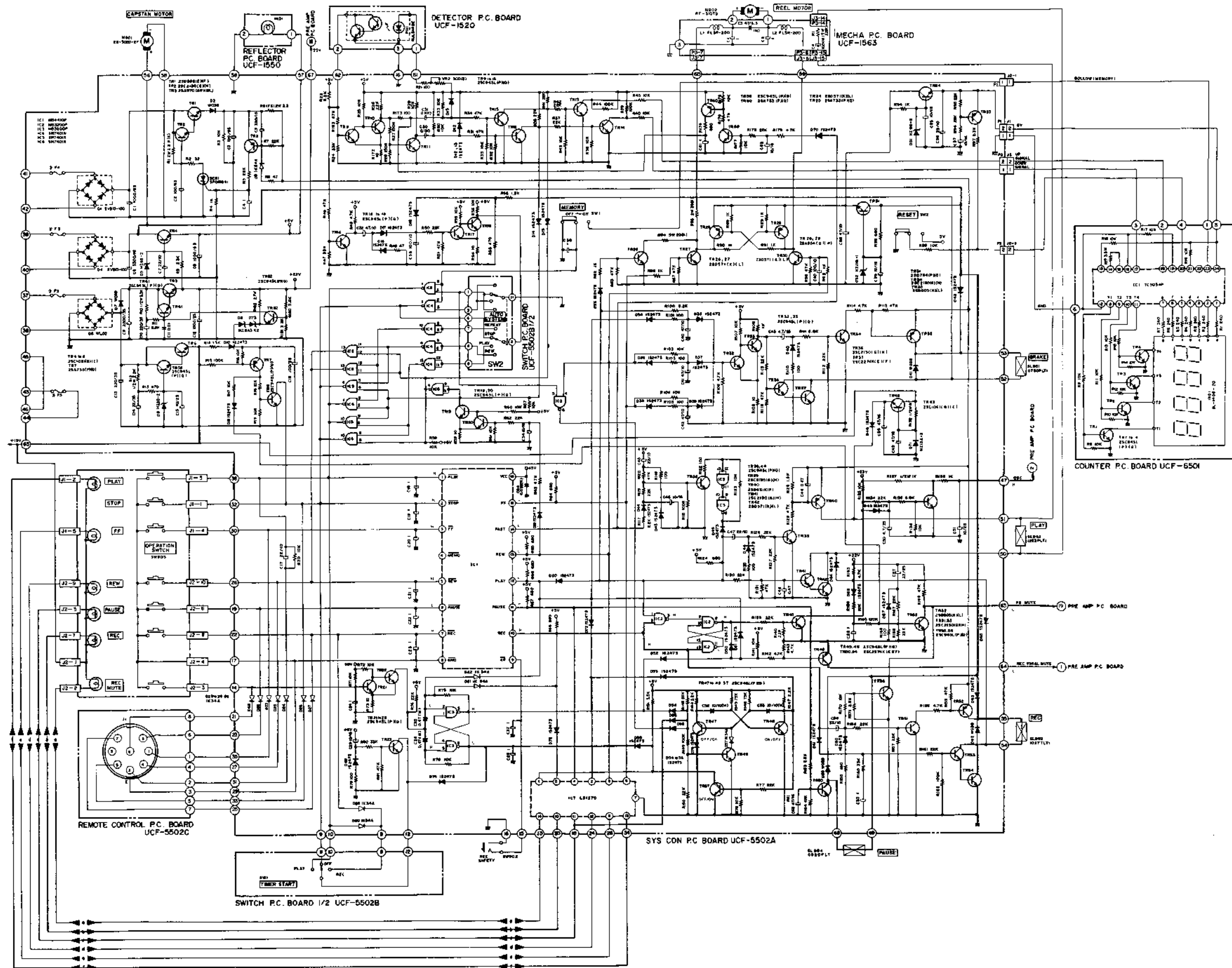

Schematic - 5 FF MODE

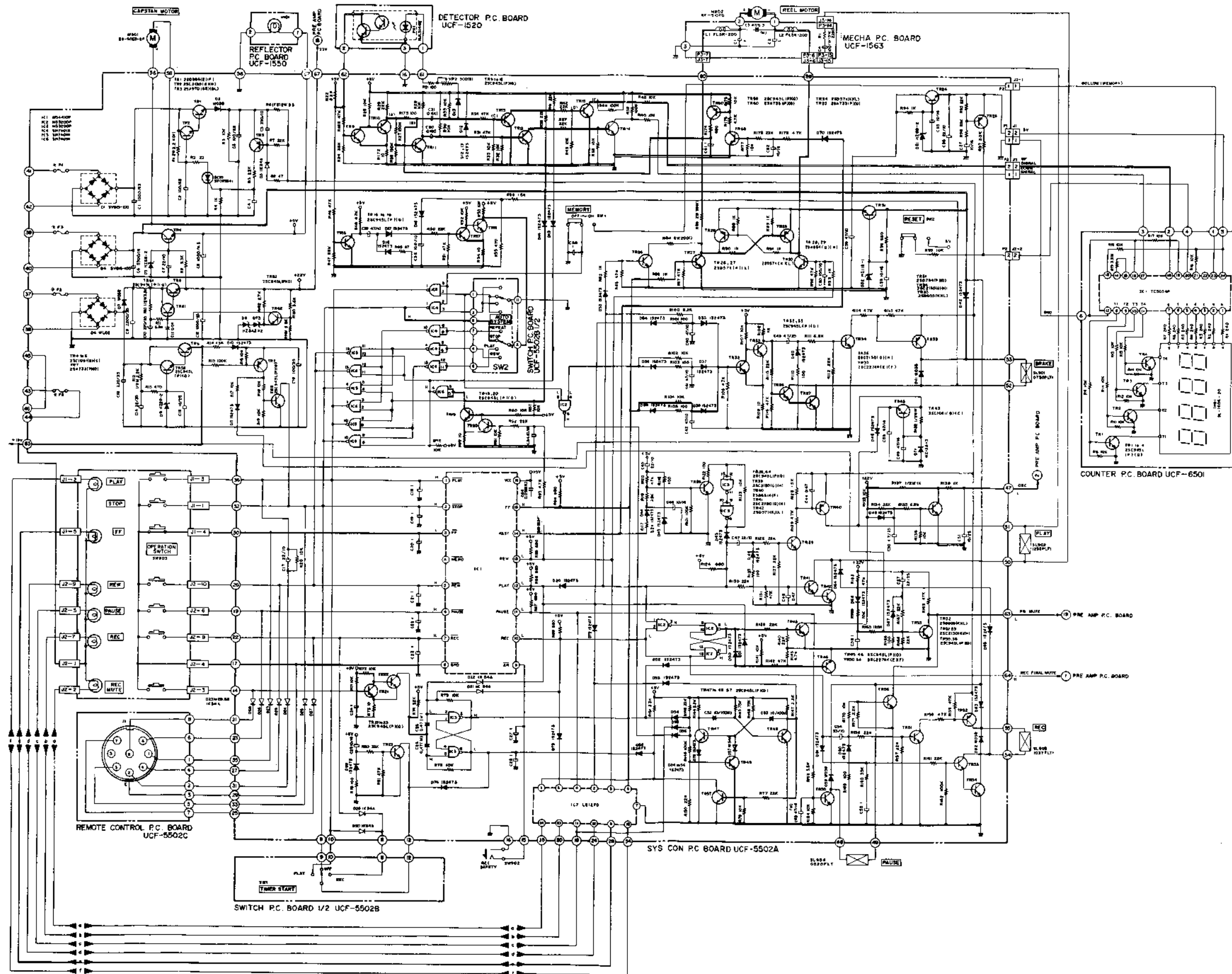

Schematic - 6 REW MODE

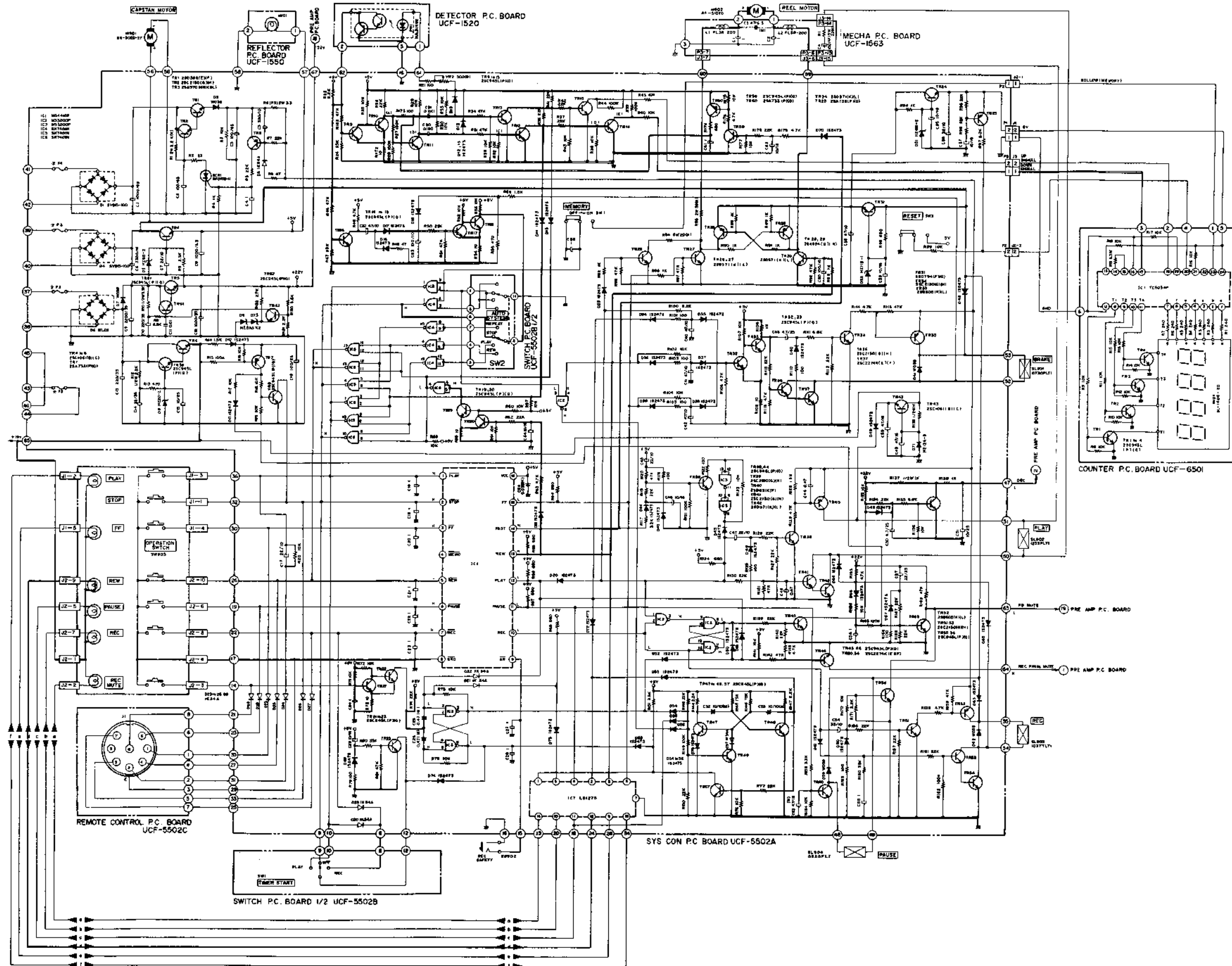

1-1. CIRCUIT CONSTRUCTION OF IC1 M54410P

This logic IC has been developed for an operation key that will maintain a HIGH output level by even a momentary low level in the desired input terminal.

1) Block Diagram

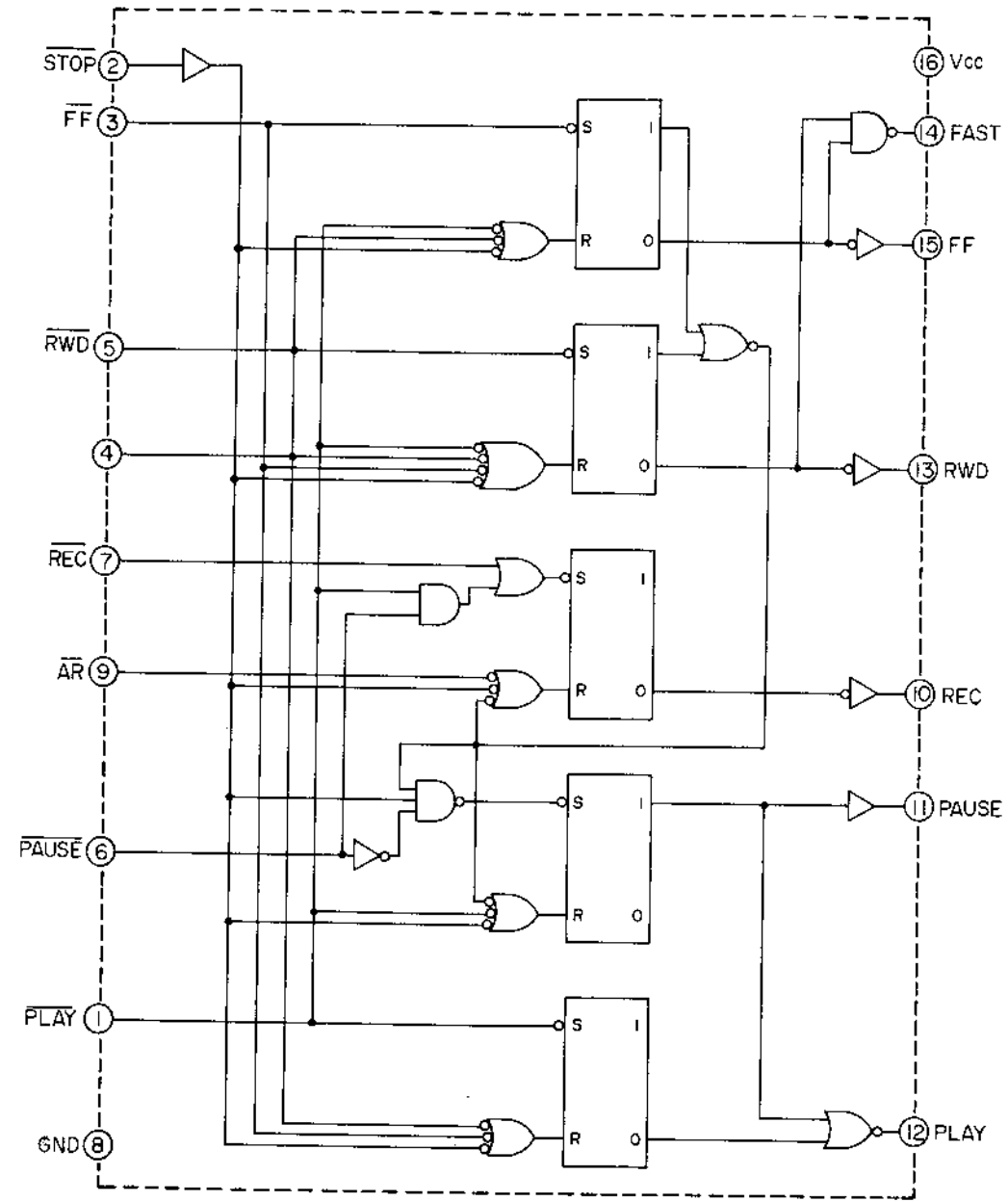

Fig. 4 M54410P

2) Terminals and their functions

	Terminal Name	Terminal Function
Operation input terminals	$\overline{\text{STOP}}$	Input terminal for stopping operation
	$\overline{\text{FF}}$	Input terminal for fast forward
	$\overline{\text{REW}}$	Input terminal for rewind
	$\overline{\text{REC}}$	Input terminal for recording
	$\overline{\text{PAUSE}}$	Input terminal for pause
	$\overline{\text{PLAY}}$	Input terminal for playback
Control input terminal $\overline{\text{AR}}$		Input terminal for preventing recording
Output terminals	FAST	Terminal with "H" signal output during fast forward or rewind mode
	FF	Terminal with "H" signal output during fast forward mode
	REW	Terminal with "H" signal output during rewind mode
	REC	Terminal with "H" signal output during REC/PLAY or REC/PAUSE mode
	PAUSE	Terminal with "H" signal output during pause mode
	PLAY	Terminal with "H" signal output during playback mode

Chart-1

3) Operation activated by each input

Input Signal	Output						Output Mode
	FAST	FF	REW	REC	PAUSE	PLAY	
$\overline{\text{STOP}}$	L	L	L	L	L	L	STOP Mode
$\overline{\text{FF}}$	H	H	L	L	L	L	FF Mode
$\overline{\text{REW}}$	H	L	H	L	L	L	REW Mode
$\overline{\text{PLAY}}$	L	L	L	L	L	H	PLAY Mode
$\overline{\text{PAUSE}}$	L	L	L	L	H	L	PAUSE Mode
$\overline{\text{REC/PLAY}}$	L	L	L	H	L	H	REC/PLAY Mode
$\overline{\text{REC/PAUSE}}$	L	L	L	H	H	L	REC/PAUSE Mode

Chart-2

- NOTES:
1. The input signal is activated by the fall of $\overline{\text{L}}$.
 2. The output is maintained until the next input signal.
 3. $\overline{\text{AR}}$ is a control input terminal and the REC output is not "H" when $\overline{\text{AR}} = \text{"L"}$.
 4. When $\overline{\text{AR}} = \text{"L"}$, signal is supplied during the REC output is "H", REC output becomes "L".
 5. At the moment the power is on, all output will be "L" and the Stop mode will be effected.

1-2. Transistor and Plunger Activated for Each Operation (Refer to Sys. Con Schematic Diagram)

	TR40	TR42	PLAY PLUNGER	TR35	TR37	BRAKE PLUNGER	TR52	TR54	REC PLUNGER	TR50	PAUSE PLUNGER
PLAY	Δ	○	○	Δ	○	○					
PLAY/PAUSE										○	○
REC/PLAY	Δ	○	○	Δ	○	○	Δ	○	○		
REC/PAUSE							Δ	○	○	○	○
FF				Δ	○	○					
REW				Δ	○	○					

○: Operating

Δ: Momentary Operation

Chart-3

2. DIGITAL COUNTER CIRCUITRY OPERATION

2-1. Circuit Structure of IC1 TC5054P

TC5054P is an IC for a 4 digit, decade up/down counter with a built-in 7 segment driver/decoder. On the inside, with the counter as base it is constructed of a 4 digit latch, multiplexer, scanning

oscillation circuit and a driver/decoder driving the LEDs directly. The clock input is separate for down and up clocks and each input has a schmitt trigger for shaping the waveform.

1) Block Diagram

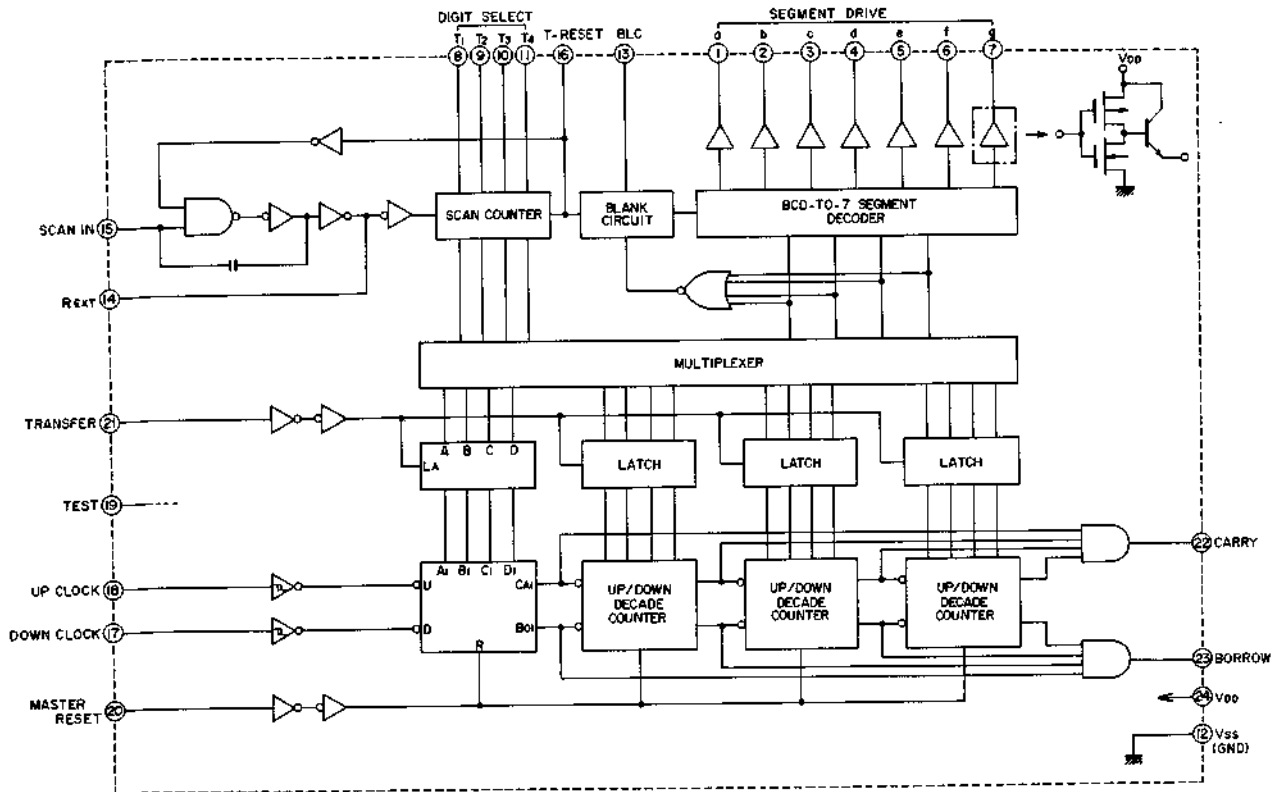

Fig. 5 TC5054P

2) Description of Pin Function

PIN NO.	SYMBOL	NAME	FUNCTION		
1	a	SEGMENT a	a-g are outputs which change the decade up/down counter BCD output in 7 segment display element drive code. These segment signals are output dynamically from the highest digit at the same time as SCAN input. Generous calculation of the IOH input enables the direct cathode common type LEDs to be driven.		
2	b	SEGMENT b			
3	c	SEGMENT c			
4	d	SEGMENT d			
5	e	SEGMENT e			
6	f	SEGMENT f			
7	g	SEGMENT g			
8	T ₁	DIGIT SELECT 1	Outputs for displaying the number of digits of a-g outputs and correspond in order to the highest digit from T ₁ . By applying the clock to the SCAN input changes T ₁ → T ₂ → T ₃ → T ₄ → T ₁ automatically.		
9	T ₂	DIGIT SELECT 2			
10	T ₃	DIGIT SELECT 3			
11	T ₄	DIGIT SELECT 4			
12	VSS	VSS	(GND)		
13	BLC	BLANKING CONTROL	"H"	Not zero suppressed	Digits higher than the position (n-1) can have the leading zero suppressed by connecting with T _n .
			"L"	All digits Leading zero suppressed	
14	REXT	REGISTER EXTERNAL	Scan clock generated if a resistor is connected in between it and S _{IN} . Open when S _{IN} is applied from outside.		
15	S _{IN}	SCAN IN	Is the clock input for the digit selection counter and if a resistor is connected between it and REXT., can oscillate itself. (Equally a pulse may be added from outside.)		
16	TR	T-COUNTER RESET	The input of "H" level can stop the SCAN counter. When TR is raised, the SCAN counter will always open scanning from T ₁ .		
17	DOWN	DOWN COUNT	With the UP input at "H" level by applying a pulse, the internal counter counts down at the raised part of the pulse.		
18	UP	UP COUNT	With the DOWN input at "H", by applying a pulse, the internal counter can count up at the raised parts of the pulse.		
19	TEST	TEST	Conducted at "L" level. (If at "H" level the count will change at the raised and lowered of the pulse.)		
20	MR	MASTER RESET	During count can be cleared to "0000" by inputting "H" level.		
21	TRF	TRANSFER	With a "H" level input, the counter's contents are usually passed through the multiplexor and then output. With "L" level input, the counter's contents are held in the LATCH circuit until it changes to "L" and even if the counter's contents change it does not change.		
22	CARRY	CARRY	During UP COUNT, when the counter registers "999", "H" level is output only while the UP CLOCK is "L" level.		
23	BORROW	BORROW	During DOWN COUNT, when the counter registers "0000", "H" level will be output only while the DOWN CLOCK input is at "L".		
24	VDD	VDD	(VDD)		

Chart-4

2-2. Count Operation

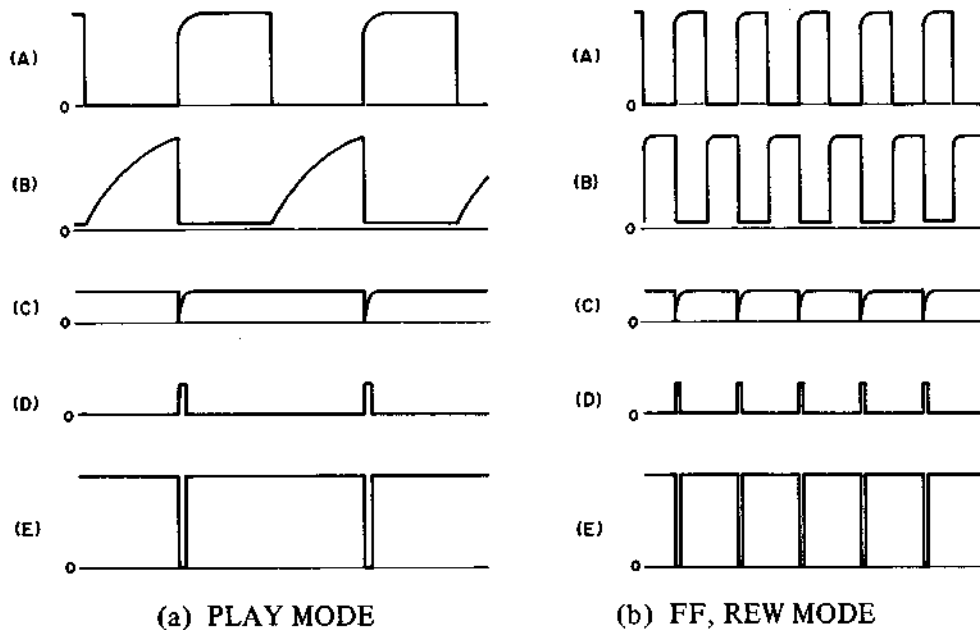

Fig. 6

The count pulse is generated by PH 1 together with the reel revolution. This pulse is amplified by TR9 and TR10, its waveform shaped by TR13 and TR15 during FF and PLAY and then it is input into TC5054P as up clock. During REW, its waveform is shaped by TR11, TR12 and TR14 and input as down clock. TR19 and TR20 switch between up clock and down clock.

1) UP Count Operation in FF or PLAY Modes

(Refer to Schematic 2, 5 and Fig. 6)

In FF or PLAY modes, as TR20 is OFF, base bias is added to TR19 through R60 turning TR19 ON. As a result, TR12's collector becomes earth potential and the count pulse is not added to TR14. In this way, the count pulse amplified by TR9 and TR10 passes through TR13 and TR15 and is input into the up count of TC5054P as up count pulse. At this point the pulse widths are different in FF and PLAY modes so TR60 is turned ON (FF mode) and OFF (PLAY mode), C61's charging curve is changed and the count operation secured. In the FF mode, as TR59 and TR60 are ON, the charging time for C61 is decided by R174-C61 and is short if compared with PLAY. In the PLAY mode, as TR54 and TR60 are OFF, the charging time for C61 is decided by (R26 + R173) - C61 and is longer than FF. In the PLAY mode, a noise pulse may be generated by light but this is eliminated by C61 by making the time longer and miscounting is prevented. Fig. 6 is the waveform of points A to E drawn in the Schematics 2, 5.

2) Down Count Operation During REW (Refer

to Schematic 6 and Fig. 6).

In the REW mode, base bias is added to TR20 and TR20 is turned ON. Next, as TR19 is OFF, "H" level is input into IC6 ⑤, ⑥ through R57 and "L" level is output to IC6 ④. As a result, TR13's collector becomes earth potential and the up count pulse is not added to the base of TR15. In this way, the count pulse amplified by TR9, TR10 passes through TR11, TR12 and TR14 and is input into the down count input of TC5054P as down count pulse.

3) Memory Stop Operation (Refer to Schematic 6)

"H" level appears in TC5054P's BORROW terminal ②③ when the counter has become "0000" at down count. When the counter reaches "0000" when set at memory stop, "H" level appears from the BORROW terminal so passing through SW1 then IC4 ② becomes "H" level.

IC4 ③ is open and "H" level because the Auto System switch is at STOP. As a result, IC41 changes to "L" level and M54410P's stop input terminal is made "L" level. In this way, it changes to STOP mode from REW when the counter reaches "0000".

4) "0000" Indication Operation When the Power is Connected.

When the power supply is connected, TR25 turns ON only while C37 is being charged and through R97 "H" level is added to TR5054P's reset terminal. The counter display shows "0000".

In this way, then the power is supplied, "H" level is added to the reset terminal so that the counter will begin from "0000".

VII. MECHANISM ADJUSTMENT

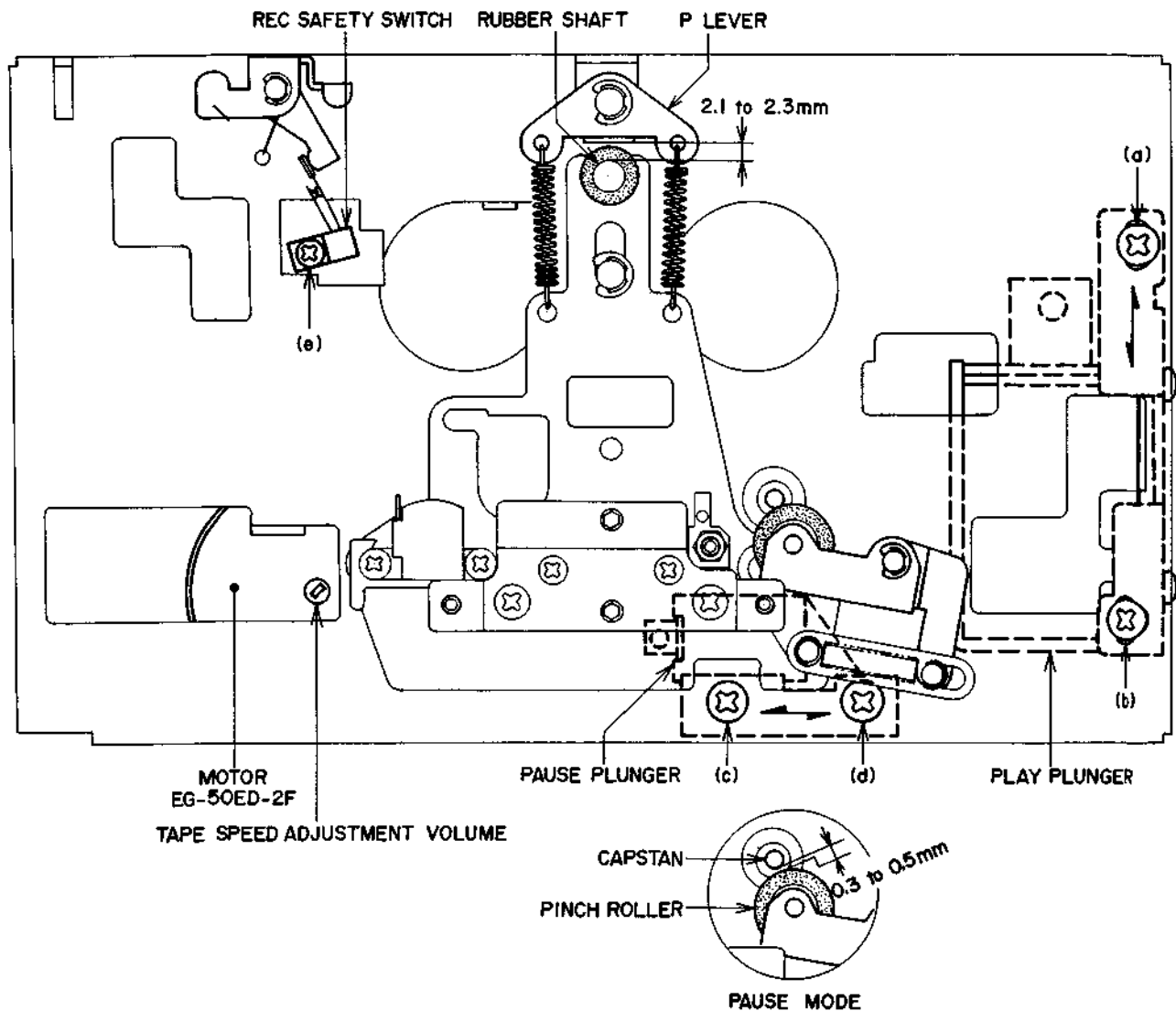

Fig. 7 Mecha Frame Block

1. PLAY PLUNGER INSTALLATION

POSITION ADJUSTMENT (Refer to Fig. 7)

Put in PLAY mode to activate the PLAY plunger. Adjust the position of the play plunger with the installation screws (a), (b) so that the distance between the top edge of the rubber shaft and the P lever is 2.1 to 2.3 mm. After adjustment coat the installation screws with screw lock.

2. PAUSE PLUNGER INSTALLATION

POSITION ADJUSTMENT (Refer to Fig. 7)

Adjust the position of the pause plunger with the installation screws (c), (d) so that the gap between the capstan and the pinch roller is 0.3 - 0.5 mm when changing from PLAY mode to PAUSE mode. After adjustment, paint lock the screws.

3. REC SAFETY SWITCH INSTALLATION

POSITION ADJUSTMENT (Refer to Fig. 7)

Using a cassette pack with the break-out tabs broken and a cassette pack with the break-out tabs unbroken, adjust the Rec Safety installation position until the conditions below are satisfied:

- a) does not enter into REC mode (switch point ON) when a cassette pack with the break-out tabs broken is inserted.
 - b) does enter into REC mode (switch point OFF) when a cassette pack with the break-out tabs unbroken is inserted.
- after adjustment, paint lock the screws.

4. TAPE SPEED ADJUSTMENT

(Refer to Fig 7)

Connect the frequency counter to the line output terminals. Playback a 1,000 Hz prerecorded test tape and adjust tape speed adjustment volume to obtain a tape speed of 1,000 Hz \pm 1.5%.

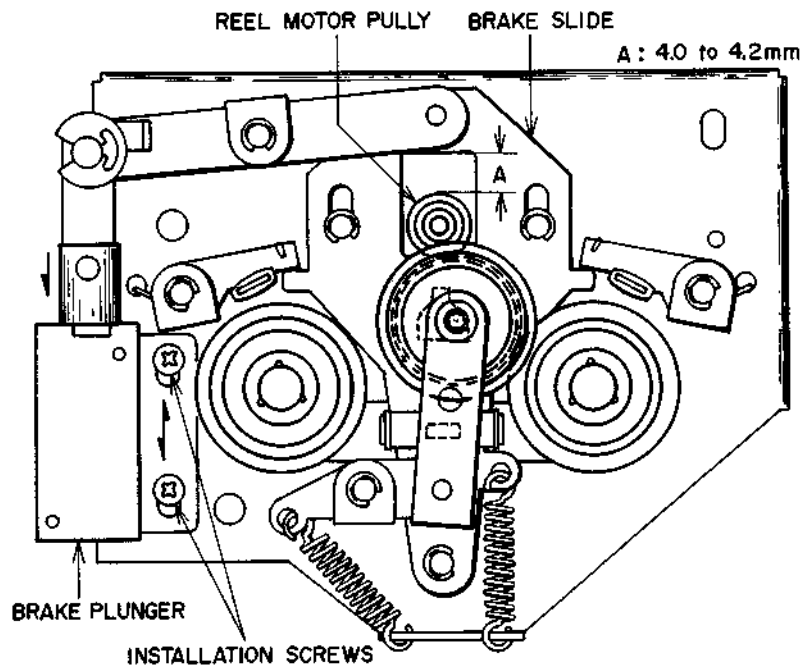

Fig. 8 Sub Frame Block

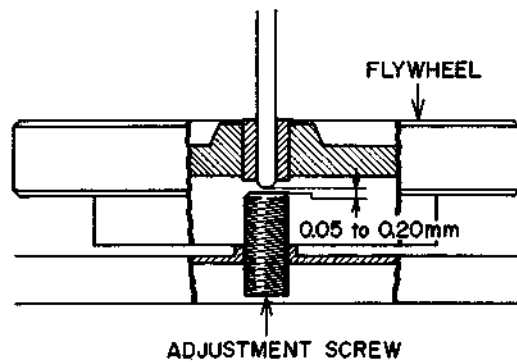

Fig. 9 Flywheel Adjustment

5. BRAKE PLUNGER INSTALLATION

POSITION ADJUSTMENT (Refer to Fig. 8)

Once the core of the brake plunger has been pushed in the direction of the arrows, (the brake plunger is in operation) loosen the two installation screws and alter their position until gap A is 4.0 to 4.2 mm. After adjustment, paint lock the screws.

6. FLYWHEEL LOOSE PLAY ADJUSTMENT

(Refer to Fig. 9)

Adjustment by turning flywheel loose play adjustment screw to obtain a 0.05 to 0.20 mm of loose play when the flywheel is moved as indicated by the arrow mark. After adjustment, paint lock the screws.

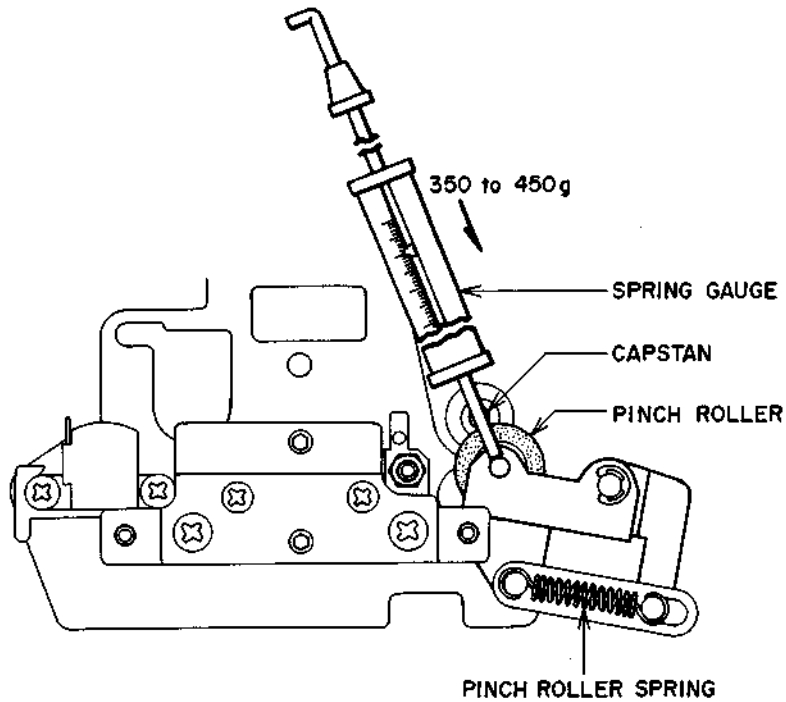

Fig. 10

7. PINCH ROLLER PRESSURE MEASUREMENT (Refer to Fig. 10)

At playback mode, push the pinch roller with a spring gauge until the pinch roller separates from the capstan by about 1 mm to 2 mm and then gently return. Take a reading of the spring gauge indication at the moment the pinch roller touches the capstan and begins to rotate

Specified Pinch Roller Pressure: 350 to 450 gm
 In case specified pressure cannot be attained, replace the pinch roller spring.

8. WINDING TORQUE MEASUREMENT IN EACH MODE

Insert cassette torque meter and measure in each mode. For fast forward and rewind measure at the end of the tape when the tape has stopped running. The specified torque is:

Play: 35 to 55 g-cm.

Fast Forward, Rewind: 70 to 120 g-cm.

When both the standard torque values are extremely small, check to see if there is any oil on the idler, reel table and motor pulley.

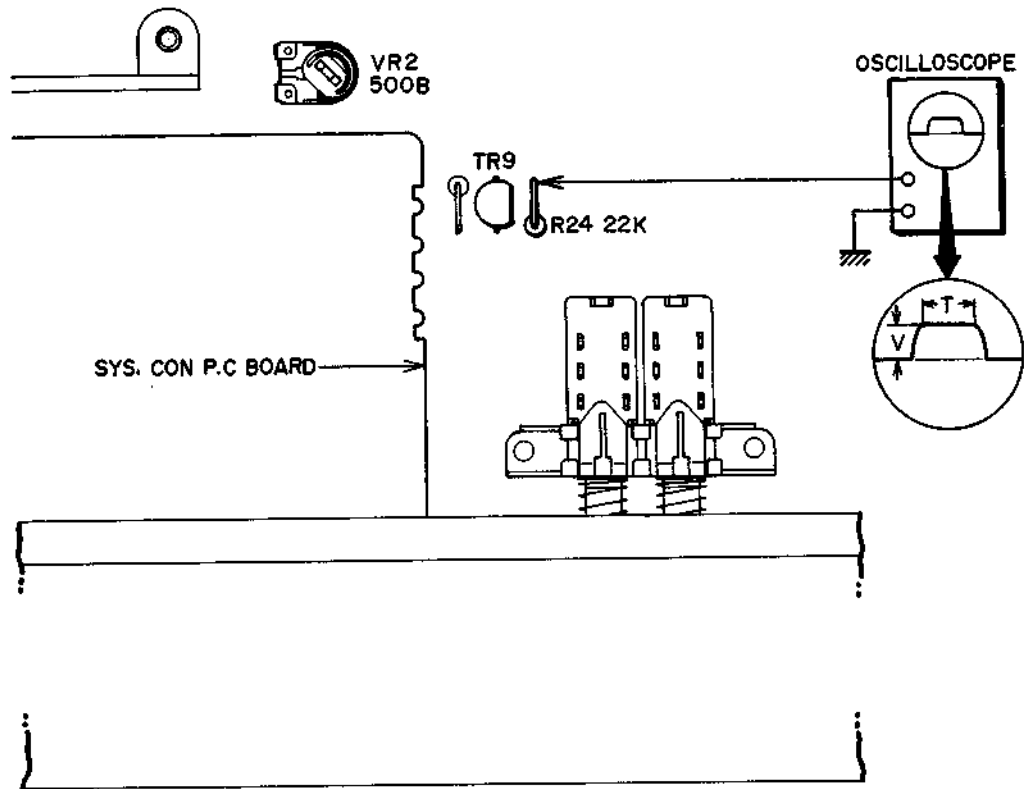

Fig. 11

9. ADJUSTMENT OF DIGITAL COUNTER'S SENSITIVITY (Refer to Fig. 11)

Make an empty pack, without the tape by removing only the tape from a TDK Low Noise Pack. Insert this cassette pack and put to PLAY mode. Connect a oscilloscope between the T.P. (R24's TR9 base side) and earth. Adjust with VR2 500B until the oscilloscope's waveform is $V > 0.2V$, $T > 7$ msec.

VIII. HEAD ADJUSTMENT

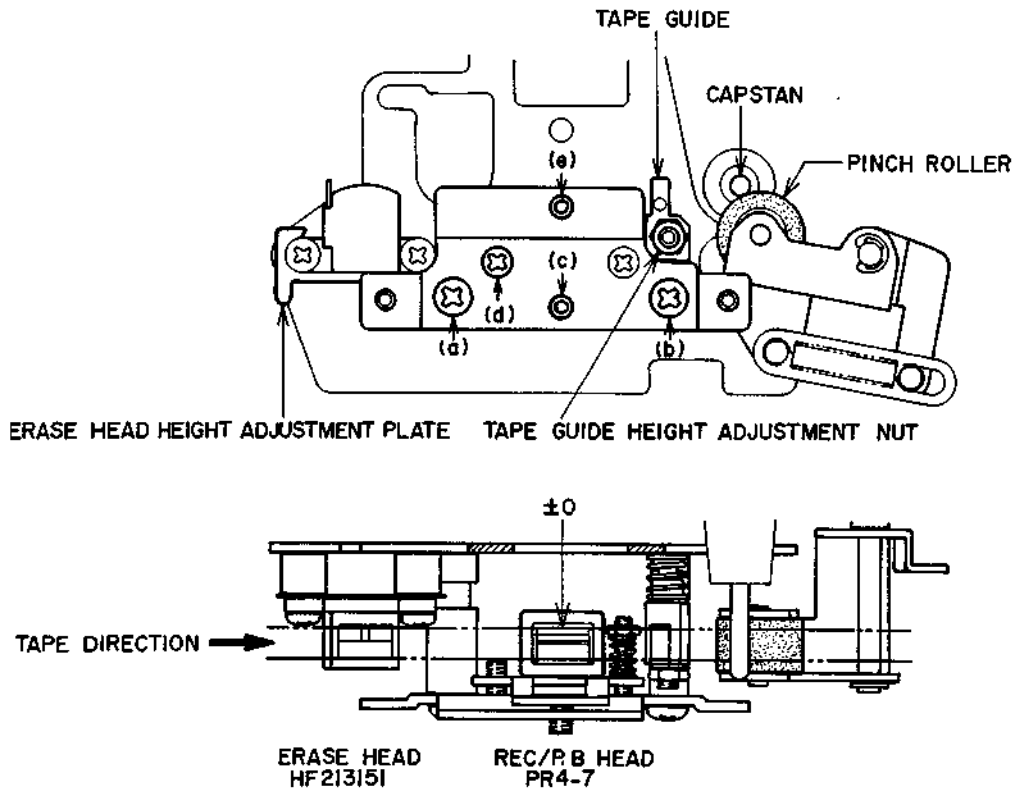

Fig. 12 Head Adjustment

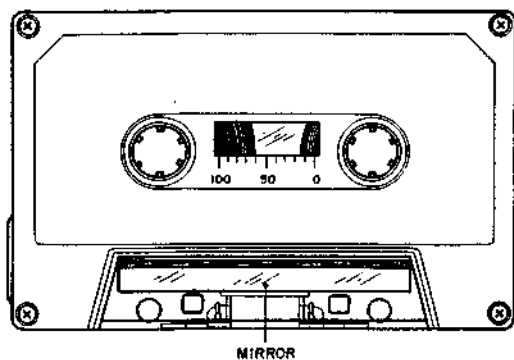

Fig. 13 Mirror Cassette

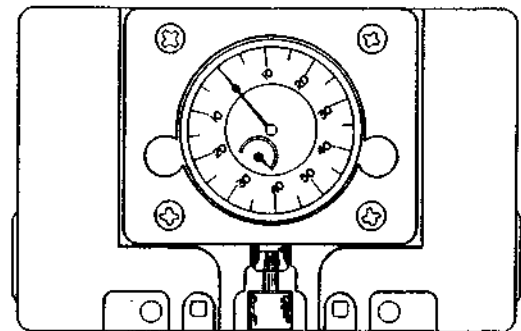

Fig. 14 AKAI Head Projection Gauge

1. TAPE GUIDE HEIGHT ADJUSTMENT

(Refer to Figs. 12, 13)

- 1) When using an ordinary cassette, the tape guides and heads, etc. are not visible. As shown in Fig. 13 use a cassette tape from which part of the cassette case has been cut out and a mirror installed for easy visibility of the head area when making tape guide height adjustment.
- 2) To adjust the height of Tape Guide (A), take the height of the Tape Guide (B) as the standard height. Normally do not adjust the height of the combined erase head and Tape Guide (B). Adjust the height of the Tape Guide (A) in the PLAY mode so that the tape runs smoothly without getting caught in a tape guide.
- 3) When changing the erase head, adjust the height of the Tape Guide (A) completely before changing

the erase head. Change the erase head. This time, taking the height of the Tape Guide (A) as the standard height, change the Erase Head height Adjustment Plate with one of different thickness and adjust the height of the Tape Guide (B).

2. REC/PB HEAD PROJECTION

ADJUSTMENT (Refer to Figs. 12, 14)

Insert the AKAI Head Projection Gauge (Fig. 14) and adjust screws (a) and (b) so that it reads 34 to 3.65 mm in the Playback Mode.

3. RECORDING/PLAYBACK HEAD HEIGHT ADJUSTMENT (Refer to Figs. 12, 13)

- 1) Utilize the cassette tape used in Tape Guide Height Adjustment above, and playback the leader tape part of cassette tape.
- 2) As shown in Fig. 12, adjust head height with screws (c), (d) and (e) until the upper edge of the tape is the same height as the upper edge of the left channel REC/PB head core.
- 3) After completing adjustment step 2), playback the Head Height adjustment tape (4 track, 1,000 Hz) and adjust Head Height adjustment screws (c), (d), (e) to put the output power from both channels to maximum.

4. RECORDING/PLAYBACK HEAD AZIMUTH ALIGNMENT ADJUSTMENT (Refer to Fig. 12)

- 1) Playback a 10 kHz pre-recorded cassette azimuth alignment test tape and adjust screw (d) shown in Fig. 12 to obtain maximum output on both channels.
- 2) Invert cassette and confirm that the output level does not change from that obtained in Item 4-1) above. If the output level differs, adjust in the same way as in Item 4-1) above until both sides of the test tape display equal output.
- 3) After adjustment, check head height and azimuth alignment again.

- NOTES:
1. Be sure to clean the heads prior to head adjustment.
 2. Be careful not to use a magnetized driver or other magnetized tools in the vicinity of the heads.
 3. Be sure to demagnetize the heads with a Head Demagnetizer before and after head adjustment.
 4. When a mirror installed cassette test tape as shown in Fig. 13 is required, it can be ordered from AKAI Electric Co.

IX. AMPLIFIER ADJUSTMENT

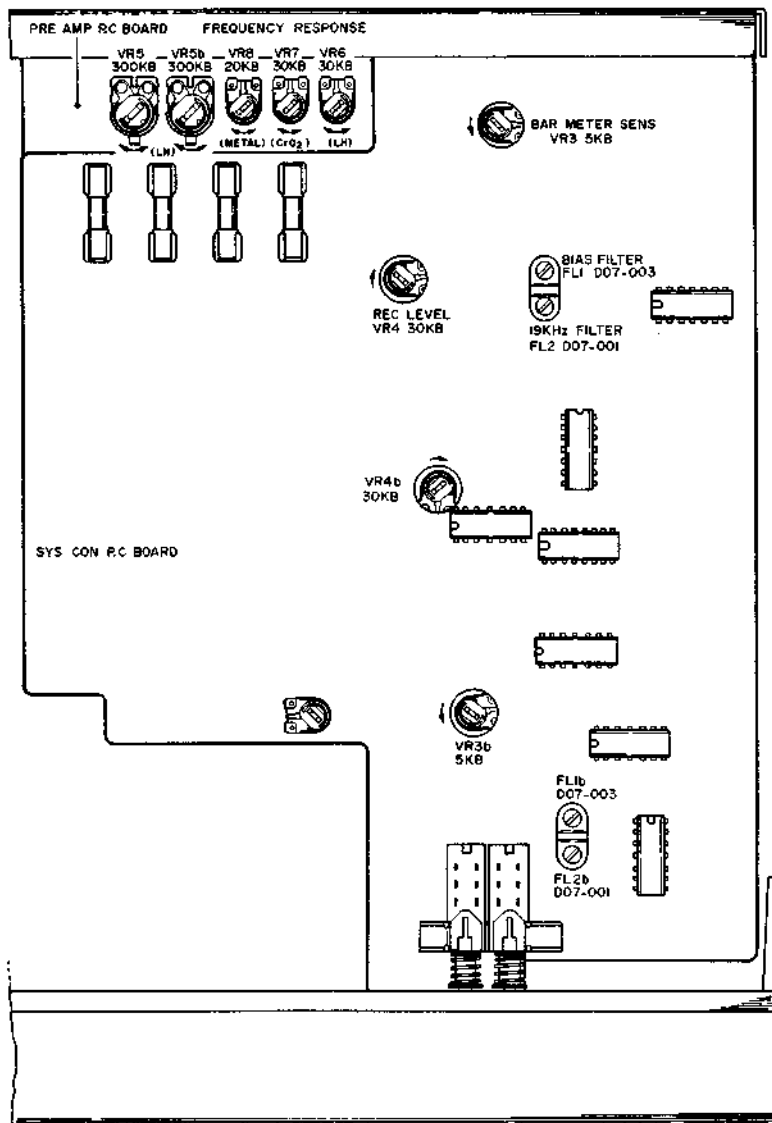

Fig. 15 Amplifier Adjustment Points (Top View)

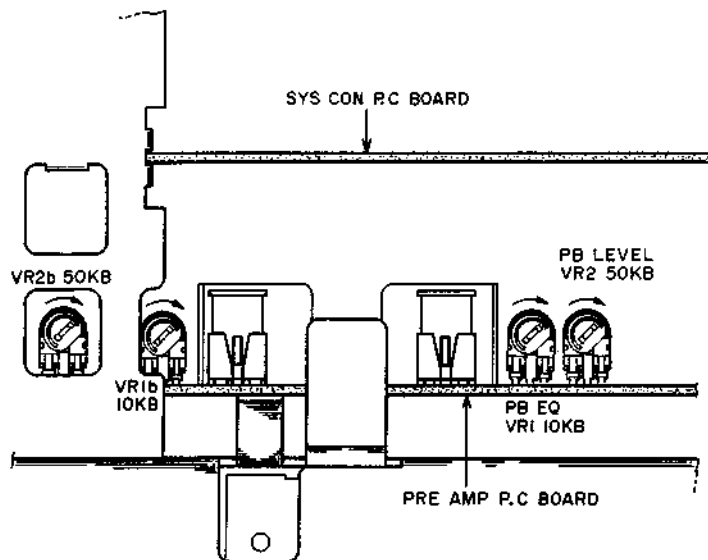

Fig. 16 Amplifier Adjustment Points (Right Side View)

Step	Adjustment Item	Test Tape Supply Signal	Mode	Adjustment Point	Result	Remarks
1	Playback Level	333 Hz, 0 VU Test Tape	PB	VR2 50 kB	-5.5 ±0.3 dBm (410 mV)	
2	Bar Meter Sensitivity	1,000 Hz -5.5 dBm from oscillator	REC	VR3 5 kB	Let +1 light up. Then turn in a direction so that +1 disappears. Adjust at the point which +1 disappears.	
3	Playback Equalizer	10 kHz Test Tape	PB	VR1 10 kB	-19.0 ±0.5 dBm	
4	LN Position Frequency Response	Low Noise blank tape. 1,000 Hz 10,000 Hz -25.5 dBm recording	REC/PB	VR5 300 kB	1,000 Hz to 10,000 Hz flat	
5	LH Position Frequency Response	LH Blank tape 1,000 Hz 10,000 Hz -25.5 dBm recording	REC/PB	VR6 30 kB	1,000 Hz to 10,000 Hz flat	Set tape selector to LH Position
6	CrO ₂ Position Frequency Response	CrO ₂ Blank tape 1,000 Hz 10,000 Hz -25.5 dBm recording	REC/PB	VR7 30 kB	1,000 Hz to 10,000 Hz flat	Set tape selector to CrO ₂ Position
7	Metal Position Frequency Response	Metal Blank tape 1,000 Hz 10,000 Hz -25.5 dBm recording	REC/PB	VR8 20 kB	1,000 Hz to 10,000 Hz flat	Set tape selector to Metal Position
8	Recording Level	LN Blank tape 1,000 Hz -5.5 dBm recording	REC/PB	VR4 30 kB	-5.5 ±0.3 dBm	Set the MIC Volume to Minimum
9	Distortion Factor Confirmation	1,000 Hz -5.5 dBm recording	REC/PB		LN < 0.8% LH < 0.8% CrO ₂ < 0.7% Metal < 0.6%	NOTE 6
10	Bias Filter	No signal input	REC	FL 1 D07-003	AC Voltmeter indicates to minimum	Set tape selector to Metal Position Set REC Volume to maximum NOTE 8
11	19 kHz Filter adjustment	19 kHz from oscillator	REC	FL 2 D07-001	AC Voltmeter indicates to minimum	Set Dolby NR Switch to ON Position. NOTES 7, 8.

Chart-5

-
- NOTES:
1. The Output Level Control should be at maximum.
 2. Because each of these adjustments is vital to perfect Dolby NR circuit operation, ensure that they are carried out with as few errors as possible.
 3. Except for Step 5 thru 7, 9 and 10, set Tape Selector to LN Position.
 4. Except for Step 12, set Dolby NR switch to OFF Position.
 5. Use the following cassette measuring tapes:

LN tape	:	TDK	D	C-60
LH tape	:	Maxell	UD	C-60
CrO ₂ tape	:	TDK	SA	C-60
Metal tape	:	TDK	MA-C	C-60
 6. If it does not comply with the specifications, repeat Steps 4 to 8 and readjust.
 7. Adjust the oscillator's frequency to give a frequency counter reading of 19.00 kHz.
 8. Unless the core is moved unintentionally this adjustment is not necessary.

X. DC RESISTANCE OF VARIOUS COILS

Parts	Designation	DC Resistance
Recording/Playback Head	PR4-7	650 ohms $\pm 10\%$
Erase Head	HF213151	3.7 ohms
Play Plunger Solenoid	1253PLTI	73 ohms $\pm 10\%$
Rec Plunger Solenoid	1037TLTI	120 ohms $\pm 10\%$
Pause Plunger Solenoid	0520FLT	600 ohms $\pm 10\%$
Brake Plunger Solenoid	0730PLTI	200 ohms $\pm 10\%$

Chart-6

XI. CLASSIFICATION OF VARIOUS P.C BOARDS

1. P.C BOARD TITLES AND IDENTIFICATION NUMBERS

P.C Board Title	P.C Board Number
Pre Amp P.C Board	UCF-5501A
Jack P.C Board	UCF-5501B
Sys. Con P.C Board	UCF-5502A
Switch P.C Board	UCF-5502B
Remo. Con P. C Board	UCF-5502C
Power Switch P.C Board	UCF-5503
Reflector P.C Board	UCF-1550
Detector P.C Board	UCF-1520
Mecha P.C Board	UCF-1563
Counter P.C Board	UCF-6501
Meter P.C Board	CE-5209

Chart-7

2. COMPOSITION OF VARIOUS P.C BOARDS

1) Sys. Con P.C Board UCF-5502A (3ED), Switch P.C Board UCF-5502B and Remote Control P.C Board UCF-5502C

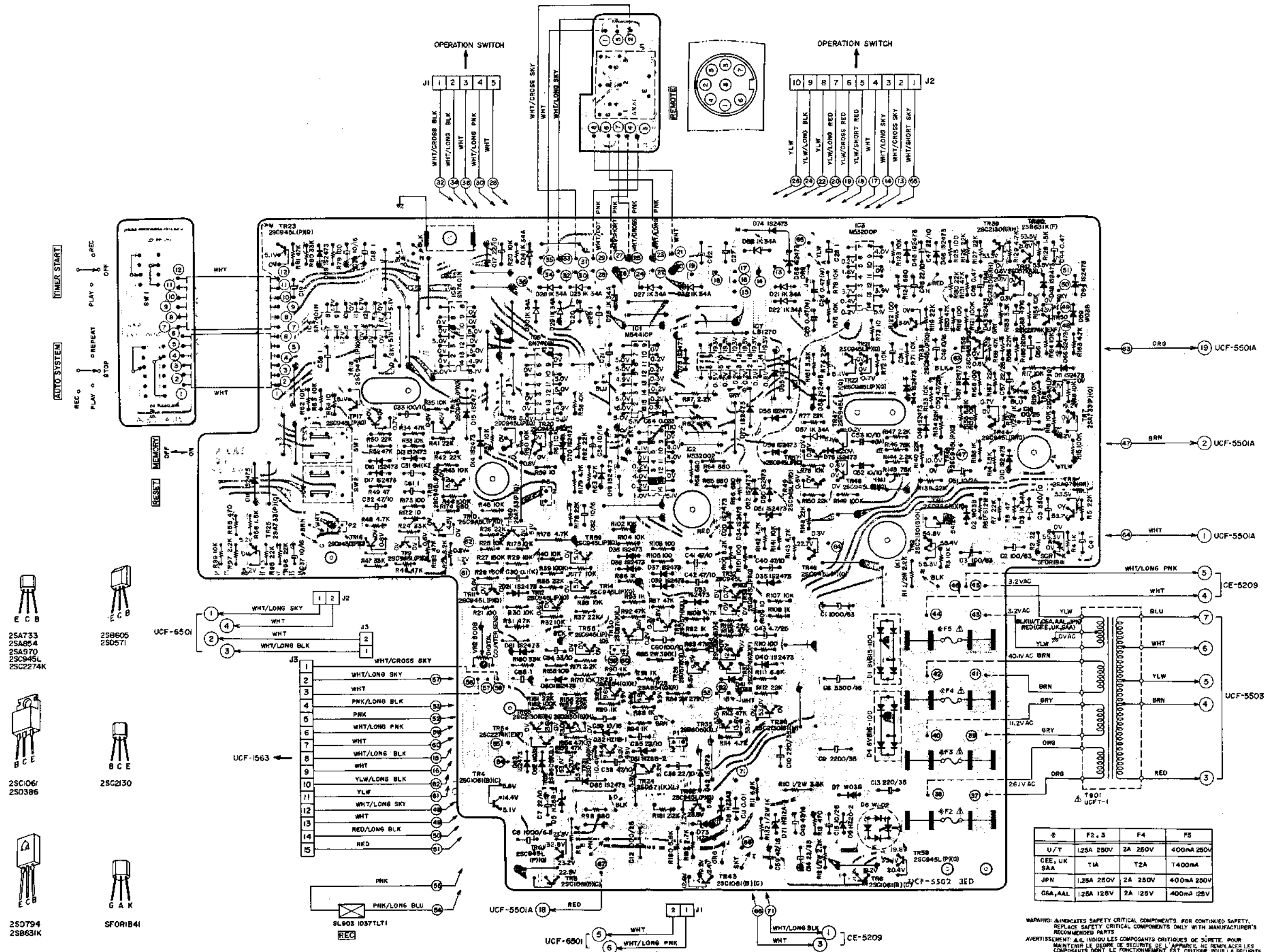

Q	F2,3	F4	F5
U/T	1.25A 280V	2A 280V	400mA 280V
CEE, UK SAA	T1A	T2A	T400mA
JPN	1.25A 280V	2A 280V	400mA 280V
OSA, AAL	1.25A 128V	2A 128V	400mA 128V

WARNING: INDICATES SAFETY CRITICAL COMPONENTS FOR CONTINUED SAFETY. REPLACE SAFETY CRITICAL COMPONENTS ONLY WITH MANUFACTURER'S RECOMMENDED PARTS.
 AVERTISSEMENT: A L'INDICOU LES COMPOSANTS CRITIQUES DE SURETE. POUR MAINTENIR LE DEGRE DE SURETE DE L'APPAREIL, NE REMPLACER LES COMPOSANTS DONT LE FONCTIONNEMENT EST CRITIQUE POUR LA SURETE QUE PAR DES PIECES RECOMMANDEES PAR LE FABRICANT.

5) Jack P.C Board UCF-5501B (3ED)

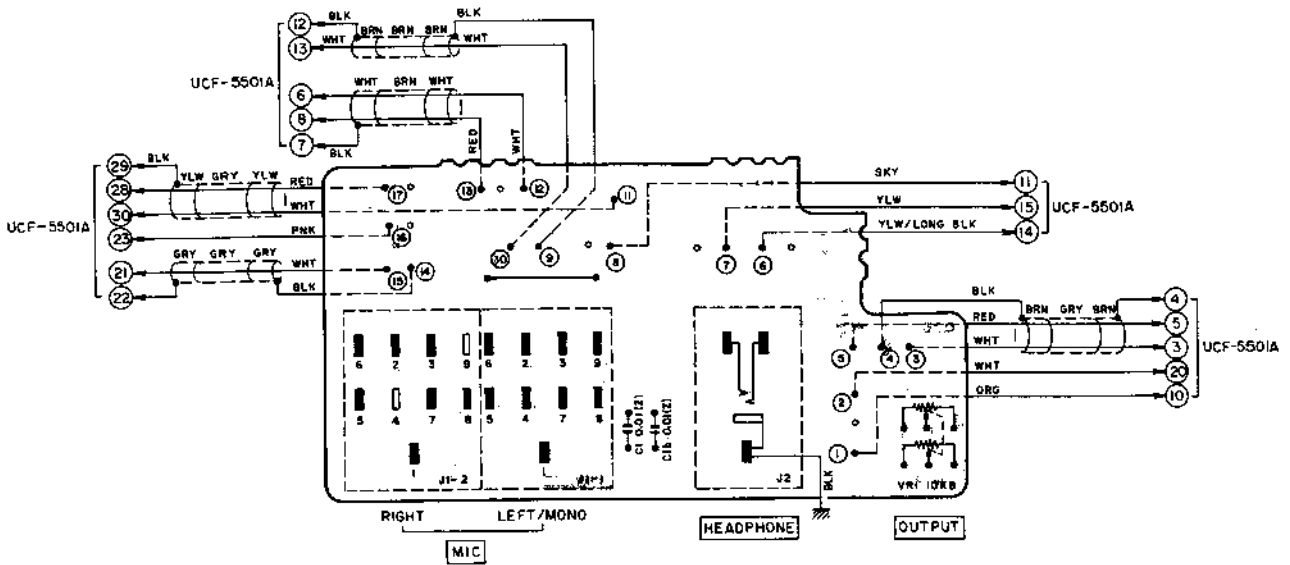

6) Mecha P.C Board UCF-1563 (3ED), Reflector P.C Board UCF-1550 and Detector P.C Board UCF-1520

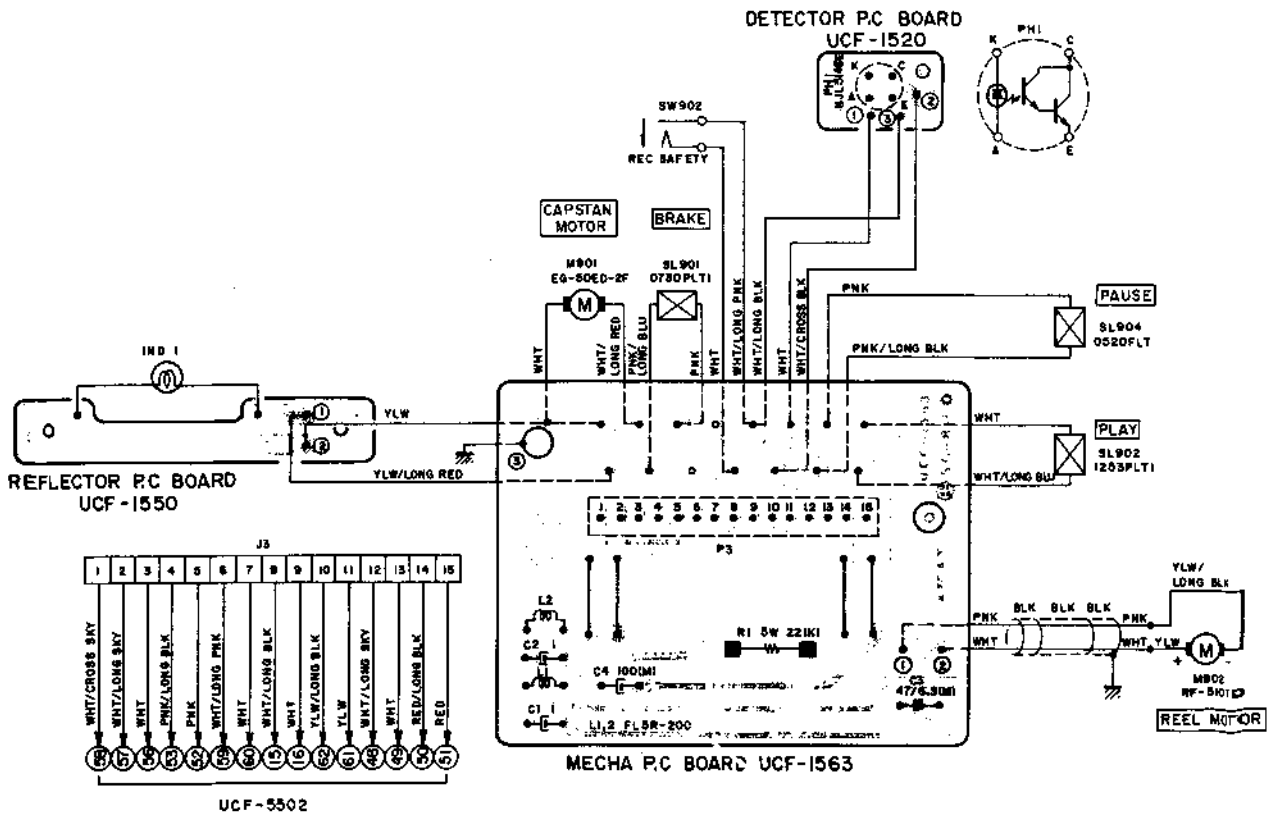

7) Power Switch P.C Board UCF-5503

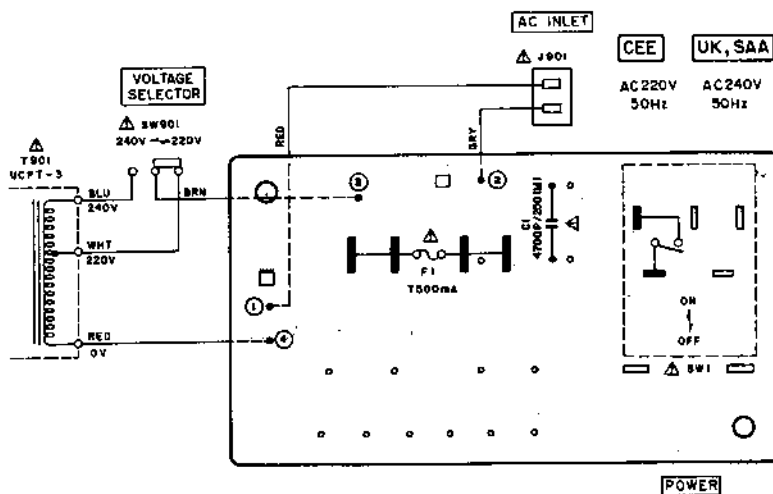
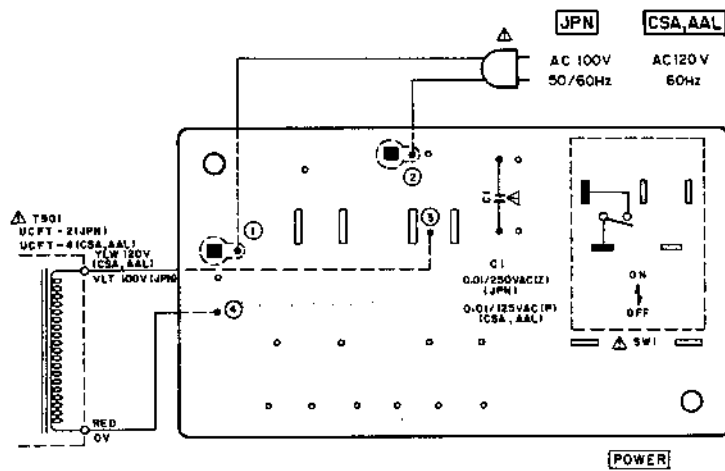
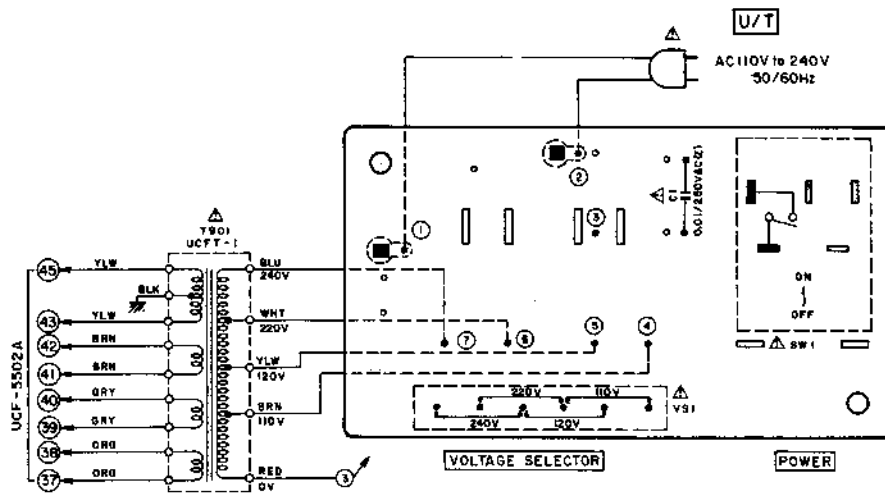

WARNING: Δ INDICATES SAFETY CRITICAL COMPONENTS. FOR CONTINUOUS SAFETY, REPLACE SAFETY CRITICAL COMPONENTS ONLY WITH MANUFACTURER'S RECOMMENDED PARTS.
 AVERTISSEMENT: Δ IL INDIQUE LES COMPOSANTS CRITIQUES DE SÛRETÉ. MAINTIENIR LE DEGRÉ DE SÛRETÉ DE L'APPAREIL NE REQUIERT PAS LE REMPLACEMENT DES COMPOSANTS SANS LE FONCTIONNEMENT EST CRITIQUE POUR LA SÛRETÉ QUE PAR DES PIÈCES RECOMMANDÉES PAR LE FABRICANT.

-MEMO-

- MEMO -

-MEMO-

SECTION 2

PARTS LIST

TABLE OF CONTENTS

1. RECOMMENDED SPARE PARTS LIST	46
2. HEAD BASE BLOCK	49
3. SUB FLAME BLOCK	50
4. MECHA ASSEMBLY BLOCK (1)	52
5. MECHA ASSEMBLY BLOCK (2)	54
6. SYS. CON P.C BOARD (UCF-5502A) BLOCK	55
7. PRE AMP P.C BOARD (UCF-5501A) BLOCK	56
8. BAR METER P.C BOARD (CE-5209) BLOCK	56
9. COUNTER P.C BOARD (UCF-6501) BLOCK	56
10. MECHA P.C BOARD (UCF-1563) BLOCK	56
11. AMP CHASSIS BLOCK	57
12. FRONT PANEL BLOCK	58
13. FINAL ASSEMBLY BLOCK	59
INDEX	60

Resistor and Capacitor which is not listed in this parts list, please refer to COMMON LIST FOR SERVICE PARTS.

HOW TO USE THIS PARTS LIST

1. This parts list is compiled by various individual blocks based on assembly process.
2. When ordering parts, please describe parts number, serial number, and model number in detail.
3. How to read list.

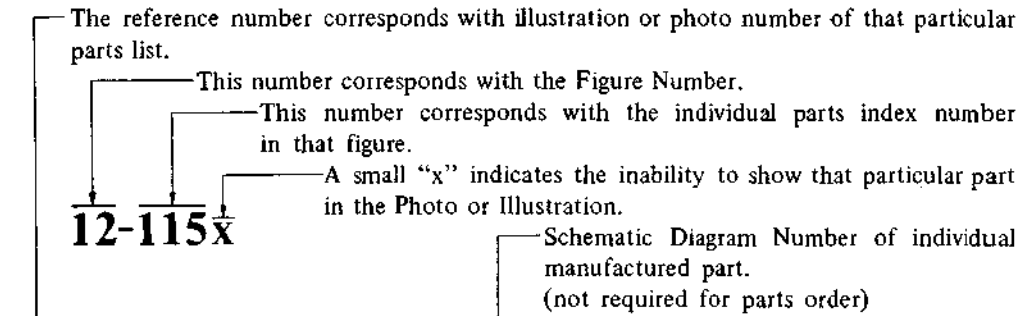

Ref. No.	Parts No.	Description	Schematic No
FLYWHEEL BLOCK #13			
12-115x	800425	Flywheel Block Assy. Comp.	RDG #13
12-116	244506	Flywheel Only	RD 233
12-117x	244754	Felt, Flywheel	RD 275
12-118	251324	Main Metal Case	RD 236
12-119	253080	Main Metal	RD 237

4. The symbol numbers shown on the P.C. Board list can be matched with the Composite Views of components of the Schematic Diagram or Service Manual.
5. The indications of Resistors and Capacitors in the photos of P.C. Board are being eliminated.
6. The shape of the parts and parts name, etc. can be confirmed by comparing them with the parts shown on the Electrical Parts Table of P.C. Board.
7. Both the kind of part and installation position can be determined by the Parts Number. To determine where a parts number is listed, utilize Parts Index at end of Parts List.
It is necessary first of all to find the Parts Number. This can be accomplished by using the Reference Number listed at right of parts number in the Parts Index. (meaning of ref. no. outlined in Item 3 above).
8. Utilize separate "Price List for Parts" to determine unit price. The most simple method of finding parts Price is to utilize the reference number.

CAUTION:

1. When placing an order for parts, be sure to list the parts no. model no., and description. There are instances in which if any of this information is omitted, parts cannot be shipped or the wrong parts will be delivered.
2. Please be careful not to make a mistake in the parts no. If the parts no. is in error, a part different from the one ordered may be delivered.
3. Because parts number and parts unit supply in the Preliminary Service Manual (Basic Parts list) may be partially changed, please use this parts list for all future reference.

WARNING: Δ INDICATES SAFETY CRITICAL COMPONENTS. FOR CONTINUED SAFETY, REPLACE SAFETY CRITICAL COMPONENTS ONLY WITH MANUFACTURER'S RECOMMENDED PARTS.

AVERTISSEMENT: Δ IL INDIQUE LES COMPOSANTS CRITIQUES DE SURETE. POUR MAINTENIR LE DEGRE DE SECURITE DE L'APPAREIL NE REMPLACER LES COMPOSANTS DONT LE FONCTIONNEMENT EST CRITIQUE POUR LA SECURITE QUE PAR DES PIECES RECOMMANDEES PAR LE FABRICANT.

AC INLET SYSTEM

This model is equipped with an AC INLET SYSTEM. Please refer to the AC INLET SYSTEM CHART below for the specific type. By the AC INLET SYSTEM, AC (mains) cord can be connected to and disconnected from the model because the model is provided with socket exclusively for AC (mains) cord on its main body. Please note, however, that certain models are not equipped with this system and has a built-in AC (mains) cord as before.

AC INLET SYSTEM CHART

CLASS I

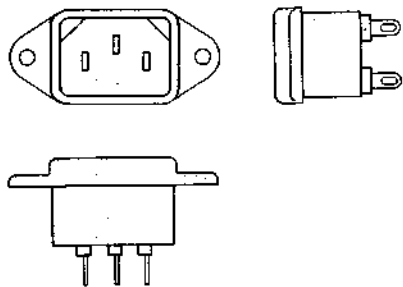

Picture 1
AC INLET
to be
installed
on machines

CLASS II

☐ This mark indicating double insulation will be attached to machine's rear panel

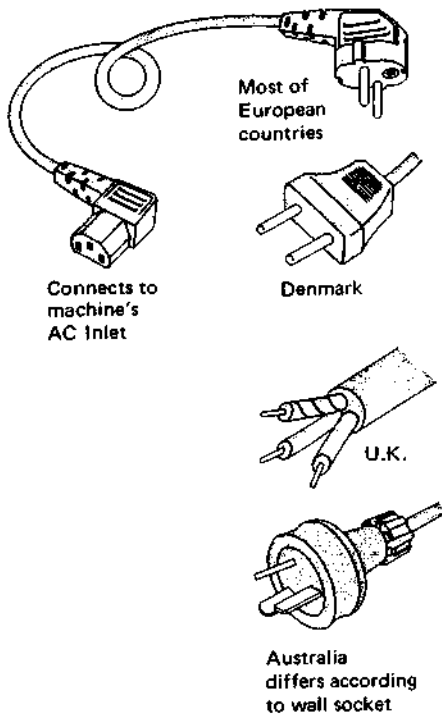
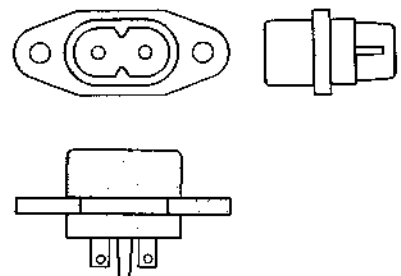

Picture 2
AC (mains)
cord

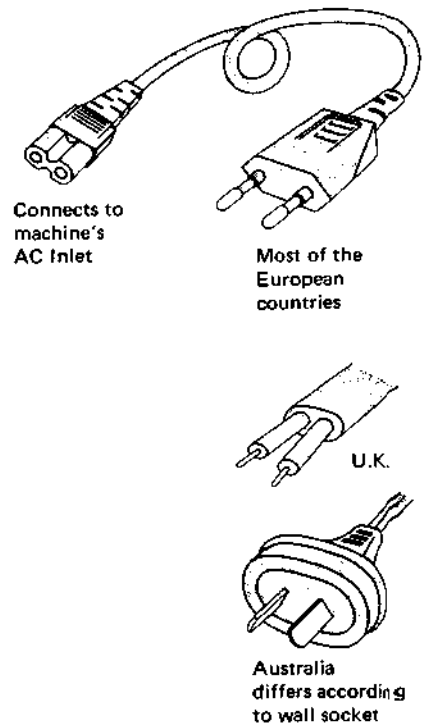

Parts List for AC (mains) Cord Set

	Standard	Description	Type of AC Inlet	Parts No.
Class I	CEE	Cord Set CEE (3 cores)	3P	EW302993
	BEAB	Cord Set BEAB (3 cores)	3P	EW302994
	SAA	Cord Set SAA (3 cores)	3P	EW302996
	U/T	Cord Set U/T (3 cores)	3P	EW302646
Class II	CEE	Cord Set CEE (2 cores)	2P	EW631144
	BEAB	Cord Set BEAB (2 cores)	2P	EW302995
	SAA	Cord Set SAA (2 cores)	2P	EW302991
	U/T	Cord Set U/T (2 cores)	2P	EW302899

1. RECOMMENDED SPARE PARTS LIST

Because, if the parts listed below are on hand, almost any repair can be accomplished, we suggest that you stock these Recommended Spare Parts Items.

Parts No.	Description	Notes
BA323658	Pre Amp PCB Comp. UC-F5	
BA324095	Sys. Con PCB Comp. UC-F5 (CEE)	CEE, UK, SAA
BA324094	Sys. Con PCB Comp. UC-F5 (CSA)	CSA, AAL
BA324093	Sys. Con PCB Comp. UC-F5 (U/T)	U/T, JPN
BF324381	Flywheel Part UC-F5	
BH323630	Head Base BLK UC-F5	
BL326857	Pinch Roller Arm Assy UC-F5	
BM324427	Capstan Motor BLK W/Pulley UC-F5	
BM323629	Reel Motor BLK W/Pulley UC-F5	
BT324069	△ Power Trans. UCFT-1	U/T
BT324070	△ Power Trans. UCFT-2	JPN
BT324071	△ Power Trans. UCFT-3	CEE, UK, SAA
BT324072	△ Power Trans. UCFT-4	CSA, AAL
EC316184	Elect./C. (Vert.) 1000 μ F 25WV	
EC315968	Elect./C. (Vert.) 1000 μ F 6.3WV	
EC315964	Elect./C. (Vert.) 1000 μ F 63WV	
EC316230	Elect./C. (Vert.) 2200 μ F 35WV	
EC315966	Elect./C. (Vert.) 3300 μ F 16WV	
ED308952	Germanium Diode 1K34A-LR	
ED324082	LED, 4 Figures 7 Segments SL-1406-20	
ED309357	Silicon Diode SVB15-100	
ED315960	Silicon Diode WL02	
ED306109	Silicon Diode W03B	
ED624903	Silicon Diode 1S2473	
ED560913	Silicon Diode 1S2473 VE	
ED316143	Silicon Diode 1S2473-HS	
ED317594	Silicon Diode 1S2473HL	
ED313513	Thyristor SF0R1B41	
ED319176	Zener Diode HZ12A-3	
ED324013	Zener Diode HZ20-2	
ED313623	Zener Diode HZ22-3	
ED326139	Zener Diode HZ3A-3	
ED309069	Zener Diode HZ6B-2	
EF309392	△ Fuse 1.25A 125V	CSA, AAL
EF306949	△ Fuse 1.25A 250V	U/T, JPN
EF306954	△ Fuse 2A 125V	CSA, AAL
EF306950	△ Fuse 2A 250V	U/T, JPN
EF308848	△ Fuse 400mA 125V	CSA, AAL
EF309389	△ Fuse 400mA 250V	U/T, JPN
EF300590	△ Fuse (EAWK) 400MAT	CEE, UK, SAA

Parts No.	Description	Notes
EF623103	△ Fuse (SEMKO T) 1AT	CEE, UK, SAA
EF601301	△ Fuse (SEMKO T) 2AT	CEE, UK, SAA
EF593706	△ Fuse (SEMKO T) 500MAT	CEE, UK, SAA
EI315799	IC HA12019	
EI322490	IC HD7401P	
EI306141	IC LA4170	
EI316170	IC LB1270	
EI308936	IC M54410P	
EI605013	IC NE545B	
EI633982	IC SN7400N	
EI323780	IC TC5054P	
EI324061	Mark Sensor NJL5146E	
EJ301513	△ Inlet 2P	CEE, UK, SAA
EJ324276	DIN Socket 8P TCS4680-01-111	
EJ316156	Head Phone Jack HLJ0315-01-020	
EJ321328	Jack HLJ0345-01-010	
EL317599	Lamp (Lead Type) 6.3V 100mA	
EM315859	Bar Meter FIP48CW16YS	
EO323789	OSC Coil 53T116	
EP324062	Plunger 0520FLT	
EP313497	Plunger 0730 PLTI	
EP324278	Plunger 1253PLTI	
EP308973	Relay LAB2NS DC24V	
ER311503	Cement/R. (Wire Wounded) 10W 20 ohms (K)	
ES315159	△ Push SW. SDG1P (JPN)	JPN
ES665875	△ Push SW. SDG1P-J TV-3 UL/CSA	CSA, AAL
ES665807	△ Push SW. SDG5P-E 5A/80A 250V	U/T, CEE, UK, SAA
ES324063	Leaf SW. BSW-47P	
ES323786	Push SW. J-K2083	
ES324009	Push SW. SUF20	
ES324271	Rotary Slide SW. SRZR104	
ES324008	Rotary SW. SBU1024x01	
ES324007	Rotary SW. SRU1023S	
ES312050	Slide SW. CL-212K12A	
ES306430	Slide SW. J-S4013 #01	
ET301464	FET 2SK68 (M)(N)	
ET554657	Transistor 2SA733 (P)(Q)	
ET315958	Transistor 2SA854 (Q)(R)	
ET305463	Transistor 2SA970 (GR) (BL)	
ET666415	Transistor 2SB605 (K)(L)	

Parts No.	Description	Notes
ET327714	Transistor 2SB631K (F)	
ET312497	Transistor 2SC1061 (B)(C) YC-40B	
ET603257	Transistor 2SC1312S (G)(H)	
ET311832	Transistor 2SC1844 (E)	
ET308937	Transistor 2SC2130 (G)(H)	
ET308937	Transistor 2SC2130 (G)(H)	
ET309353	Transistor 2SC2274 (E)(F)	
ET308977	Transistor 2SC2274K (F)	
ET639437	Transistor 2SC945L (Q)(P)	
ET313514	Transistor 2SD386 (E)(F)	
ET666404	Transistor 2SD571 (K)(L)	
ET307349	Transistor 2SD794 (P)(Q)	
EV324396	Double-Axial 2-Throw/Vol. DM20R545A-50kAx2	
EV324397	Single-Axial 2-Throw/Vol. GN20R522-10kBx2	
EW306427	△ AC Cord (JPN)	
EW306428	△ AC Cord (U/T)	
EW305691	△ AC Cord CUL	CSA, AAL
EW322400	△ AC Cord Set Basec 2 Cores	UK
EW315767	△ AC Cord Set CEE 2 Cores	CEE
EW322401	△ AC Cord Set SAA 2 Cores	SAA
HE321585	Erase Head HF213151	
HP319079	REC/PB Head PR4-7	
MB323681	Capstan Belt	
MB323686	Detection Belt	
MI309414	Idler Part	
MT312122	Reel Table Part GXC-715D	
MV309146	Main Case	

2. HEAD BASE BLOCK

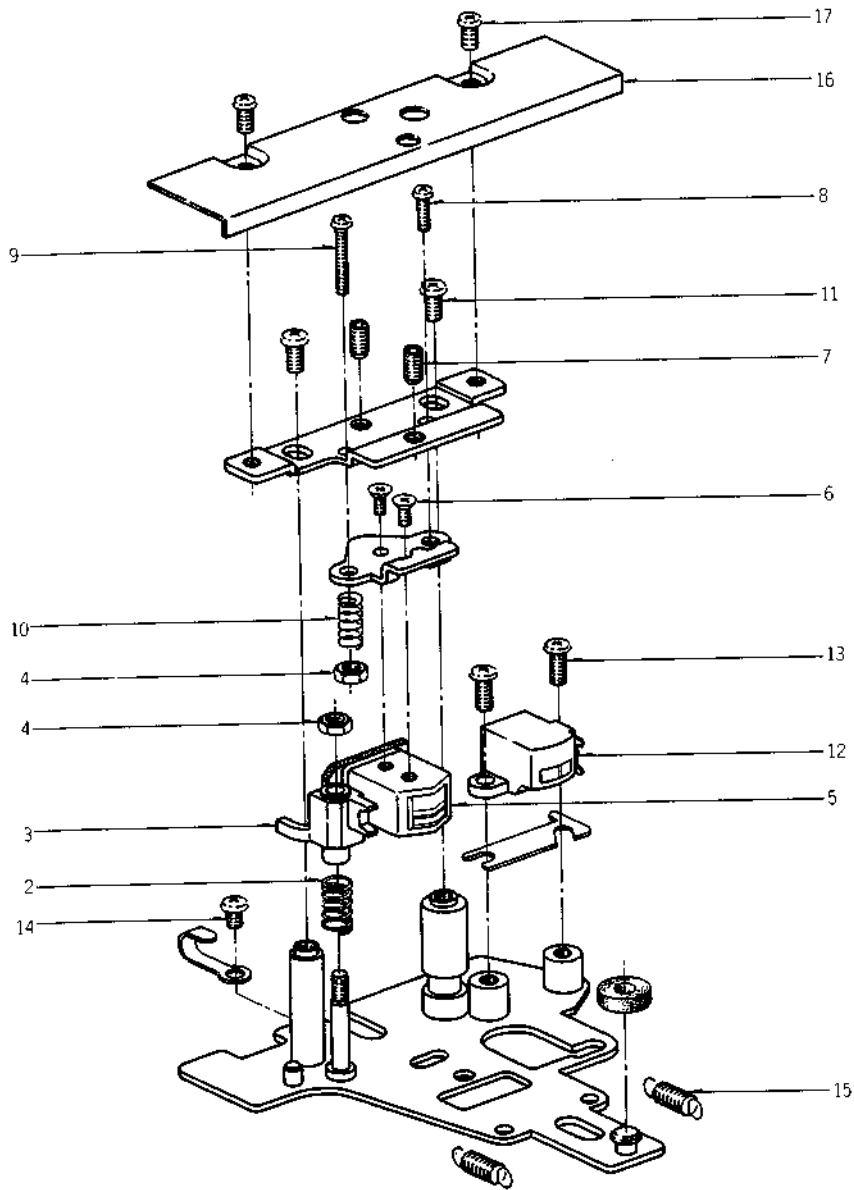

HEAD BASE BLOCK

Ref. No.	Parts No.	Description	Schematic No.
2-1x	BH323630	Head Base BLK UC-F5	
2-2	ZG289236	Tape Guide Spring	CM-0005
2-3	HZ309128	Tape Guide	CF-0006
2-4	ZW591265	Nut M2.3, #3	
2-5	HP319079	REC/PB Head PR4-7	
2-6	ZS524812	Screw, Countersunk 2x4	
2-7	ZS356804	Set Screw, Hexagon Socket 3x4 (CUP/P)	
2-8	ZS590804	Screw, pan 2.3x6	
2-9	ZS462947	Screw, pan 2.3x12	
2-10	ZG465636	Angle Adjust Spring	CG-0029
2-11	ZS419782	Screw, bind 2.6x5	
2-12	HE321585	Erase Head HF213151	37-2-33
2-13	ZS464692	Screw, bind 2.3x6	
2-14	ZS417161	Screw, pan 2.3x4	
2-15	ZG323715	P Spring	UCF-1548
2-16	TC323725	Head Decoration Plate	UCF-1557, 1558
2-17	ZS267254	Screw, pan 2.3x4 (Black)	

When ordering parts, please quote Parts Number, Description and Model Number.

3. SUB FRAME BLOCK

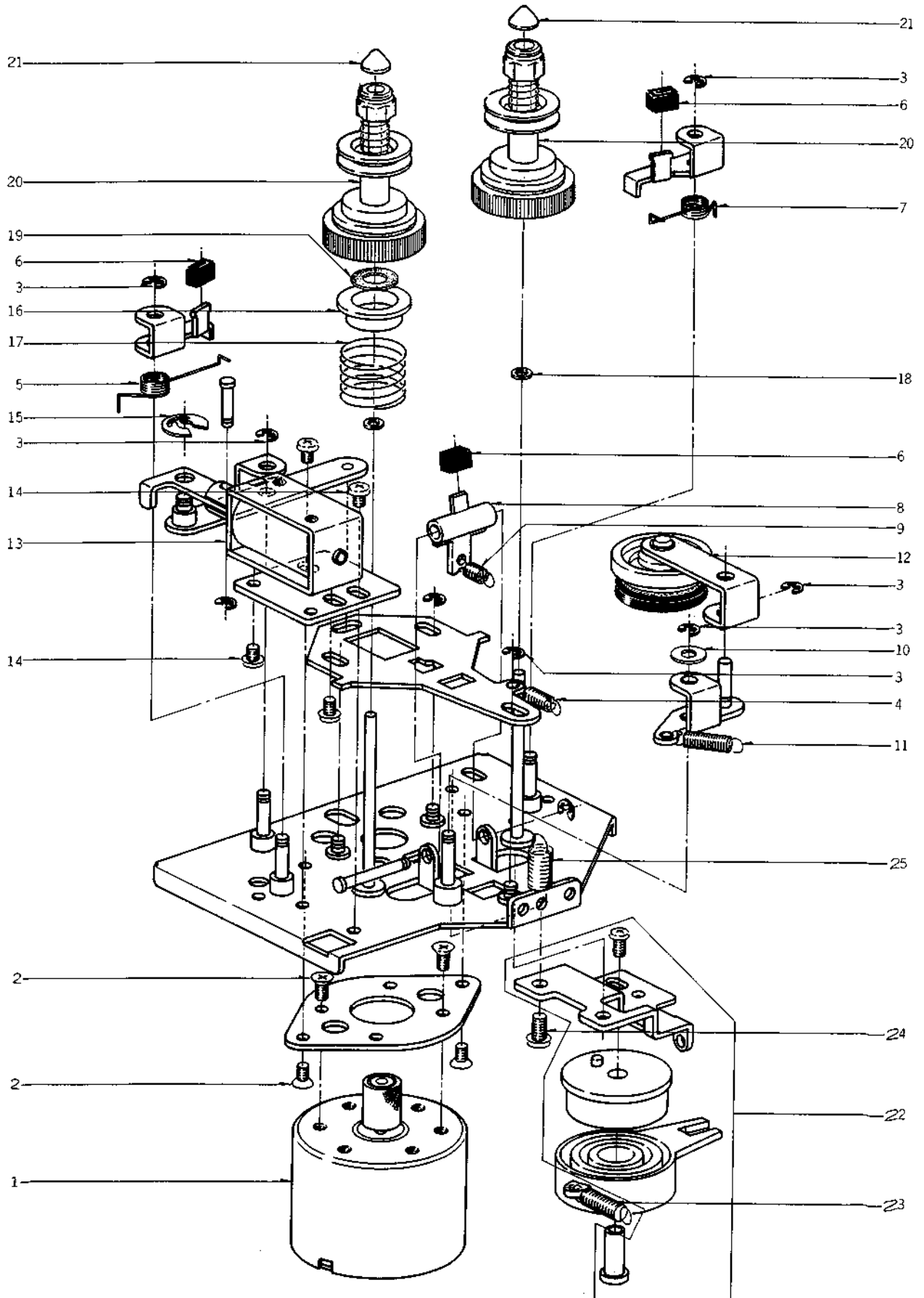

SUB FRAME BLOCK

Ref. No.	Parts No.	Description	Schematic No.
REEL MOTOR BLOCK			
3-1	BM323629	Reel Motor BLK W/Pulley UC-F5	UCF-7002
3-2	ZS430413	Screw, Countersunk 2.6x4	
SUB FRAME BLOCK			
3-3	ZW270088	'E' Ring 1.9M	6-1-9
3-4	ZG365433	Idler Tension Spring	RCC-1365
3-5	ZG309225	Brake Spring (L)	CF-2022
3-6	MB282104	Brake Rubber	CN-1020
3-7	ZG309226	Brake Spring (R)	CF-2023
3-8	ML309229	Pad Lever	CF-2035
3-9	ZG469315	Take-up Lever Spring	CG-1091
3-10	ZW432753	Washer (PBP) D3.1x8x0.2t	
3-11	ZG322048	Idler Spring (B)	CX-1105
3-12	MI309414	Idler Part	13-2-42
3-13	EP313497	Plunger 0730PLT1	44-1-108
3-14	ZS592378	Screw, pan 2.6x3	
3-15	ZW290283	'U' Ring 2.85M	6-1-1
3-16	TC317433	Torque Drum	CU-2010
3-17	ZG323736	Back Tension Spring	UCF-2502
3-18	ZW381644	Washer (Polyslider) D2.1x4.0x0.13t	
3-19	ZW322912	Oil Washer	CU-2013
3-20	MT312122	Reel Table Part GXC-715D	13-2-41
3-21	MT305793	Reel Cap	CF-2039
3-22	TC323627	Clutch Bracket Assy	UCF-2503
3-23	ZG313001	Coil Spring T1-4.0/0.4-22.4	
3-24	ZS417216	Screw, pan 3x4	
3-25	ZG595506	Stop Spring	CH-3007

4. MECHA ASSEMBLY BLOCK (1)

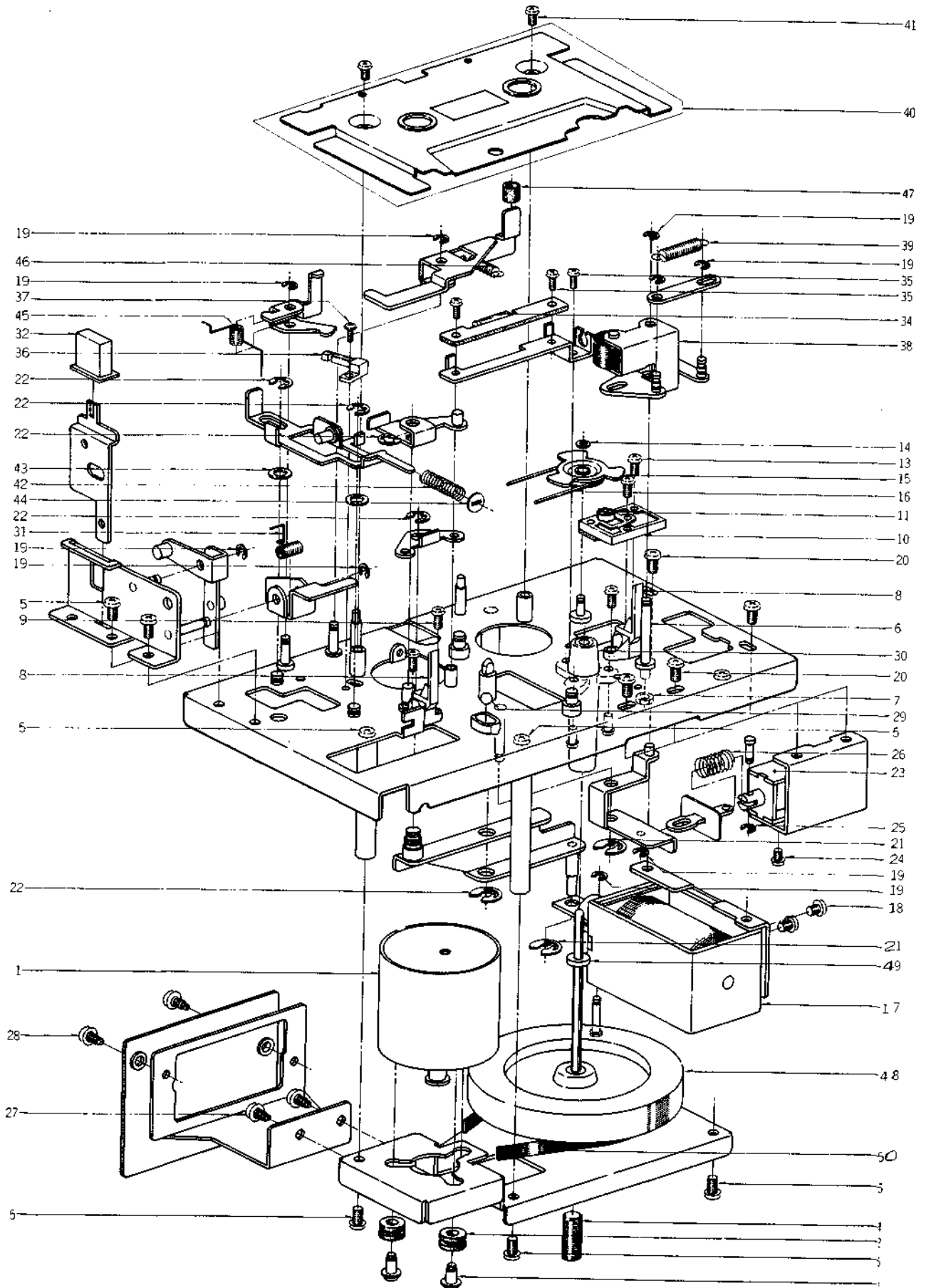

MECHA ASSEMBLY BLOCK (1)

Ref. No.	Parts No.	Description	Schematic No.
CAPSTAN MOTOR BLOCK			
4-1	BM324427	Capstan Motor BLK W/Pulley UC-F5	UCF-7001
4-2	MB282778	Rubber Bush	CN-7003
4-3	ZS321338	Motor Screw	7-1-75
4-4	ZS302318	Hold Screw	CL-1258
MECHA ASSEMBLY BLOCK			
4-5	ZS422076	Screw, pan 3x5	
4-6	MS309141	Pinch Roller Lever Shaft	CF-1011
4-7	ZW590207	Nut M3 #3	
4-8	TC309145	Cassette Guide	CF-1015
4-9	ZS479474	Screw, pan 2.6x5	
4-10	TC323621	Detection Base Assy	UCF-1573
4-11	E1324061	Mark Sensor NJL5146E	45-18-2
4-12x	ZS609074	Tapping Screw, #2 pan 2x5	
4-13	ZS537085	Screw, bind 2x5	
4-14	ZW321437	Push Washer	CE-1077
4-15	MR323683	Detection Pulley	UCF-1519
4-16	MB323686	Detection Belt	UCF-1521
4-17	EP324278	Plunger 1253PLTI	44-1-128
4-18	ZS324374	Screw, pan 3x3.5 (Blue)	
4-19	ZW270088	'E' Ring 1.9M	6-1-9
4-20	ZS323728	Screw, bind 3x5	
4-21	ZW290283	'U' Ring 2.85M	6-1-1
4-22	ZW270101	'E' Ring 3M	6-1-9
4-23	EP324062	Plunger 0520FLT	44-1-129
4-24	ZS477876	Screw, pan 2x3	
4-25	ZW356657	'E' Ring 1.5M	6-1-9
4-26	ZG370350	Reel Table Spring	RCC-1344
4-27	ZS325495	Tapping Screw, #2 BR 3x6	
4-28	ZS447840	Tapping Screw, #2 BR 3x8	
4-29	MV269965	Steel Ball D4	
4-30	MV309146	Main Case	CY-1042
4-31	ZG323699	Eject Lock Spring	UCF-1532
4-32	SB323696	Button (A)	UCF-1530
4-33x	SB323697	Button (A-BL)	UCF-1530
4-34	EL317599	Lamp (Lead Type) 6.3V 100mA	28-2-80
4-35	ZS608095	Screw, pan 2x5	
4-36	ES324063	Leaf SW. BSW-47P	25-10-41
4-37	ZS464703	Screw, bind 2x4	
4-38	BL326857	Pinch Roller Arm Assy UC-F5	
4-39	ZG323714	Pinch Roller Spring	UCF-1547
4-40	TC324289	Decoration Plate Part UC-F5	UCF-1581
4-41	ZS318208	Screw, Truss 2.3x4 (Black)	
4-42	ZG324400	Slide Spring	UCF-1567
4-43	ZW322525	Washer (PBP) D4.1x7x0.2t	
4-44	ZW323734	Stop Washer	UCF-1566
4-45	ZG323702	REC Safety Spring	UCF-1535
4-46	ZG312964	Coil Spring T1-3.2/0.45-18.0	
4-47	TC324401	Cassette Holder Cap	UCF-1564
4-48	BF324381	Flywheel Part UC-F5	UCF-1515
4-49	ZW309295	Thrust Washer	CY-1037
4-50	MB323681	Capstan Belt	UCF-1517

5. MECHA ASSEMBLY BLOCK (2)

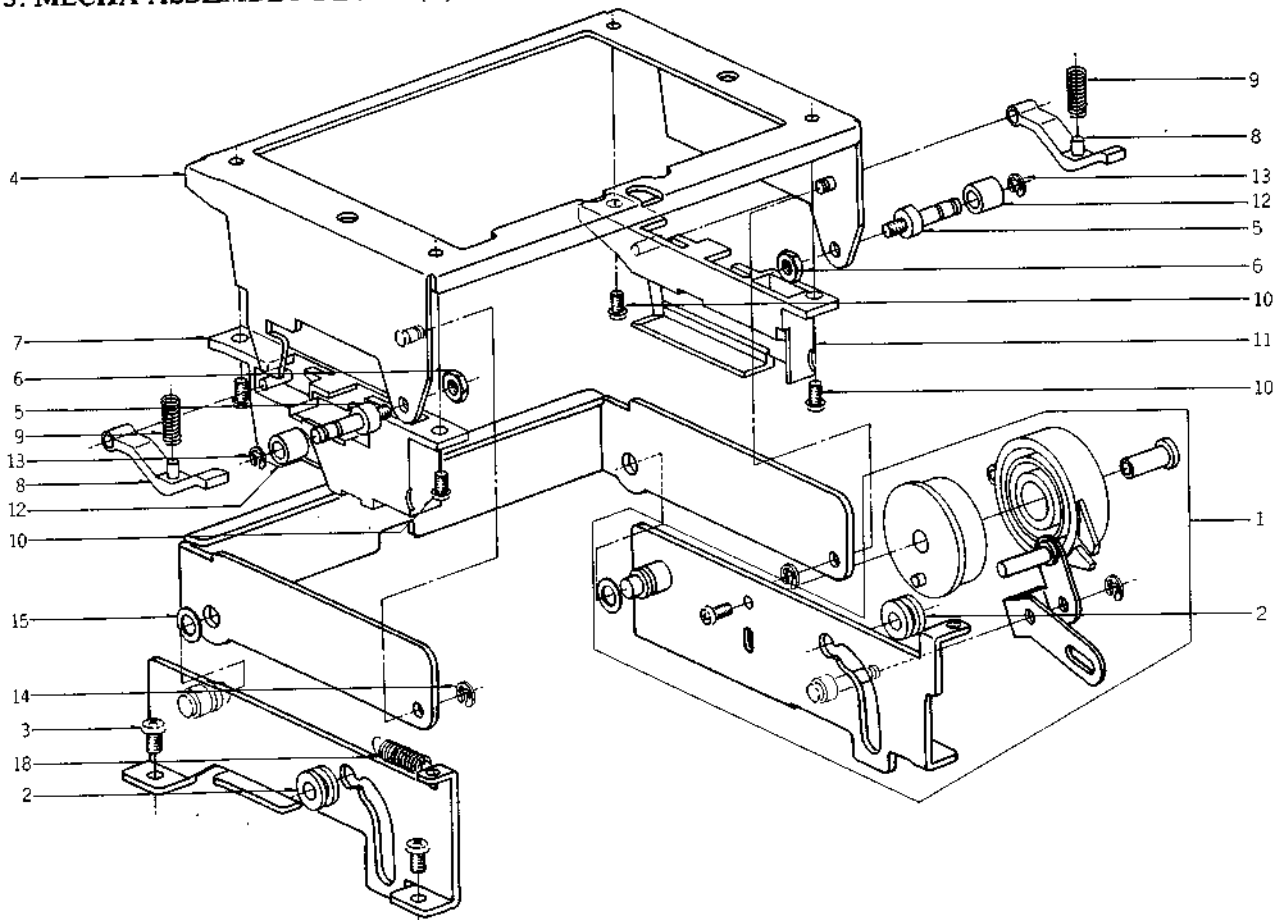

MECHA ASSEMBLY BLOCK (2)

Ref. No.	Parts No.	Description	Schematic No.
EJECT BASE (R) BLOCK			
5-1	BZ323633	Eject Base (R) BLK	UCF-1571
MECHA ASSEMBLY BLOCK			
5-2	MB282778	Rubber Bush	CN-7003
5-3	ZS422076	Screw, pan 3x5	
5-4	TC324298	LID Frame Part UC-F5	UCF-1551
5-5	MH323720	Eject Roller Prop	UCF-1552
5-6	ZW590207	Nut M3 #3	
5-7	TC317454	Cassette Holder (A)	CU-3016
5-8	TC309206	Setting Shoe	CF-1072
5-9	ZG313165	Coil Spring C-3.5/0.32-10.0	
5-10	ZS608185	Screw, pan 2.6x4 (Black)	
5-11	TC317455	Cassette Holder (B)	CU-3017
5-12	MR323722	Eject Roller	UCF-1554
5-13	ZW357164	'E' Ring 2.3M	6-1-9
5-14	ZW270088	'E' Ring 1.9M	6-1-9
5-15	ZW322525	Washer (PBP) D4.1x7x0.2t	
5-16x	ZW649991	Washer (PBP) D4.1x7x0.3t	
5-17x	ZW589893	Washer (PBP) D4.1x7x0.4t	
5-18	ZG312999	Coil Spring T1-4.0/0.4-20.0	

6. SYS. CON P.C BOARD (UCF-5502A) BLOCK

Symbol No.	Parts No.	Description	Schematic No.	Symbol No.	Parts No.	Description	Schematic No.
6-1	BA324093	Sys. Con PCB Comp. UC-F5 (U/T) (U/T,JPN)	UCF-5502A	6-D60,61	ED560913	Silicon Diode 1S2473VE	45-3-23
6-2	BA324094	Sys. Con PCB Comp. UC-F5 (CSA) (CSA,AAL)	UCF-5502A	6-D62	ED306109	Silicon Diode W03B	45-2-78
6-3	BA324095	Sys. Con PCB Comp. UC-F5 (CEE) (CEE,UK,SAA)	UCF-5502A	6-D63to67	ED560913	Silicon Diode 1S2473VE	45-3-23
6-IC1	EI308936	IC M54410P	45-8-304	6-D68	ED308952	Germanium Diode 1K34A-LR	45-3-47
6-IC2,3	EI633982	IC SN7400N	45-8-142	6-D69,70	ED560913	Silicon Diode 1S2473VE	45-3-23
6-IC4to6	EI322490	IC HD7401P	45-8-409	6-D71	ED319176	Zener Diode HZ12A-3	45-6-80
6-IC7	EI316170	IC LB1270	45-8-369	6-D72	ED316143	Silicon Diode 1S2473-HS	45-3-53
6-TR1	ET313514	Transistor 2SD386(E)(F)	45-1-352	6-D73	ED326139	Zener Diode HZ3A-3	45-6-80
6-TR2	ET308937	Transistor 2SC2130(G)(H)	45-1-317	6-D74	ED624903	Silicon Diode 1S2473	45-3-28
6-TR3	ET305463	Transistor 2SA970 (GR)(BL)	45-1-303	6-D75,76	ED560913	Silicon Diode 1S2473VE	45-3-23
6-TR4to6	ET312497	Transistor 2SC1061 (B)(C) YC-40B	45-1-96	6-SW1-2	ES324009	Push SW. SUF20	25-5-352
6-TR7	ET554657	Transistor 2SA733(P)(Q)	45-1-124	6-VR2	EV321682	Semi-Fixed/Vol. D8 Axial 500 ohms B	36-10-280
6-TR8to23	ET639437	Transistor 2SC945L(Q)(P)	45-1-85	6-SCR1	ED313513	Thyristor SF0R1B41	45-13-4
6-TR24	ET666404	Transistor 2SD571(K)(L)	45-1-218	6-R1	ER312487	Metal Oxide Film/R. 2W 2.2k (K)	35-15-8
6-TR25	ET554657	Transistor 2SA733(P)(Q)	45-1-124	6-R6	ER319177	Metal Film/R. F 2W 3.3 ohms (J)	35-19-7
6-TR26,27	ET666404	Transistor 2SD571(K)(L)	45-1-218	6-R85	ER324081	Metal Oxide Film/R. F 2W 39 ohms (K)	35-15-8
6-TR28,29	ET315958	Transistor 2SA854(Q)(R)	45-1-325	6-C1	EC315964	Elect./C. (Vert.) 1000µF 63WV	24-12-46
6-TR30	ET666404	Transistor 2SD571(K)(L)	45-1-218	6-C6	EC315966	Elect./C. (Vert.) 3300µF 16WV	24-12-46
6-TR31	ET307349	Transistor 2SD794(P)(Q)	45-1-334	6-C8	EC315968	Elect./C. (Vert.) 1000µF 6.3WV	24-12-46
6-TR32,33	ET639437	Transistor 2SC945L(Q)(P)	45-1-85	6-C9	EC316230	Elect./C. (Vert.) 2200µF 35WV	24-12-46
6-TR34	ET308937	Transistor 2SC2130(G)(H)	45-1-317	6-C12	EC316184	Elect./C. (Vert.) 1000µF 25WV	24-12-46
6-TR35	ET666415	Transistor 2SB605(K)(L)	45-1-225	6-C25,26	EC308940	NP/C. 0.47µF(M) 50WV	24-17-31
6-TR36	ET308937	Transistor 2SC2130(G)(H)	45-1-317	6-C52,53	EC324076	NP/C. 10µF(M) 10WV	24-17-31
6-TR37	ET309353	Transistor 2SC2274(E)(F)	45-1-335	6-4	ZS421806	Screw, pan 3x8	
6-TR38	ET639437	Transistor 2SC945L(Q)(P)	45-1-85	6-5	ZW273756	Nut, #1 M3	
6-TR39	ET308937	Transistor 2SC2130(G)(H)	45-1-317	6-6	ZW563218	Washer (Bake) D3.2x10x11	
6-TR40	ET327714	Transistor 2SB631K(F)	45-1-277	6-7	ZS379350	Screw, pan 3x6	
6-TR41	ET308937	Transistor 2SC2130(G)(H)	45-1-317				
6-TR42	ET666404	Transistor 2SD571(K)(L)	45-1-218				
6-TR43	ET312497	Transistor 2SC1061(B)(C) YC-40B	45-1-96				
6-TR44to49	ET639437	Transistor 2SC945L(Q)(P)	45-1-85				
6-TR50	ET309353	Transistor 2SC2274(E)(F)	45-1-335				
6-TR51	ET308937	Transistor 2SC2130(G)(H)	45-1-317				
6-TR52	ET666415	Transistor 2SB605(K)(L)	45-1-225				
6-TR53	ET308937	Transistor 2SC2130(G)(H)	45-1-317				
6-TR54	ET309353	Transistor 2SC2274(E)(F)	45-1-335				
6-TR55to59	ET639437	Transistor 2SC945L(Q)(P)	45-1-85				
6-TR60	ET554657	Transistor 2SA733(P)(Q)	45-1-124				
6-TR61,62	ET639437	Transistor 2SC945L(Q)(P)	45-1-85				
6-D1	ED309357	Silicon Diode SVB15-100	45-2-83				
6-D2	ED306109	Silicon Diode W03B	45-2-78				
6-D3	ED308952	Germanium Diode 1K34A-LR	45-3-47				
6-D4	ED309357	Silicon Diode SVB15-100	45-2-83				
6-D5	ED309069	Zener Diode HZ6B-2	45-6-80				
6-D6	ED315960	Silicon Diode WL02	45-2-93				
6-D7	ED306109	Silicon Diode W03B	45-2-78				
6-D8	ED313623	Zener Diode HZ22-3	45-6-80				
6-D9	ED324013	Zener Diode HZ20-2	45-6-80				
6-D10to14	ED560913	Silicon Diode 1S2473 VE	45-3-23				
6-D15	ED317594	Silicon Diode 1S2473HL	45-3-60				
6-D16,17	ED560913	Silicon Diode 1S2473VE	45-3-23				
6-D18	ED316143	Silicon Diode 1S2473-HS	45-3-53				
6-D19,20	ED560913	Silicon Diode 1S2473VE	45-3-23				
6-D21to30	ED308952	Germanium Diode 1K34A-LR	45-3-47				
6-D31	ED309069	Zener Diode HZ6B-2	45-6-80				
6-D32	ED319176	Zener Diode HZ12A-3	45-6-80				
6-D33to40	ED560913	Silicon Diode 1S2473VE	45-3-23				
6-D41	ED306109	Silicon Diode W03B	45-2-78				
6-D42	ED316143	Silicon Diode 1S2473-HS	45-3-53				
6-D43to46	ED560913	Silicon Diode 1S2473VE	45-3-23				
6-D48to54	ED560913	Silicon Diode 1S2473VE	45-3-23				
6-D55	ED317594	Silicon Diode 1S2473HL	45-3-60				
6-D56	ED560913	Silicon Diode 1S2473VE	45-3-23				
6-D57	ED308952	Germanium Diode 1K34A-LR	45-3-47				
6-D58	ED560913	Silicon Diode 1S2473VE	45-3-23				
6-D59	ED306109	Silicon Diode W03B	45-2-78				

When ordering parts, please quote Parts Number, Description and Model Number.

7. PRE AMP P.C BOARD (UCF-5501A) BLOCK

Symbol No.	Parts No.	Description	Schematic No.
7-1	BA323658	Pre Amp PCB Comp. UC-F5	UCF-5501A
7-IC1	EI605013	IC NE545B	45-8-117
7-IC2	EI306141	IC LA4170	45-8-305
7-TR1	ET311832	Transistor 2SC1844(E)	45-1-327
7-TR2	ET603257	Transistor 2SC1312S(G)(H)	45-1-182
7-TR3to8	ET639437	Transistor 2SC945L(Q)(P)	45-1-85
7-TR9	ET301464	FET 2SK68(M)(N)	45-12-14
7-TR10,11	ET639437	Transistor 2SC945L(Q)(P)	45-1-85
7-TR12,13	ET308977	Transistor 2SC2274K(F)	45-1-335
7-TR14	ET307349	Transistor 2SD794(P)(Q)	45-1-334
7-TR15	ET639437	Transistor 2SC945L(Q)(P)	45-1-85
7-D1	ED308952	Germanium Diode 1K34A-LR	45-3-47
7-D2	ED560913	Silicon Diode 1S2473 VE	45-3-23
7-D3,4	ED308952	Germanium Diode 1K34A-LR	45-3-47
7-D5to10	ED560913	Silicon Diode 1S2473 VE	45-3-23
7-SW1	ES312050	Slide SW. CL-212K12A	25-3-163
7-SW2	ES323786	Push SW. J-K2083	25-5-351
7-SW3	ES324271	Rotary Slide SW. SRZR104	25-6-185
7-VR1	EV324366	Semi-Fixed/Vol. V10K8-1-2 B10K	36-10-255
7-VR2	EV306737	Semi-Fixed/Vol. V10K8-1-2 50kB	36-10-255
7-VR3	EV315412	Semi-Fixed/Vol. D8 Axial 5kB	36-10-280
7-VR4	EV322416	Semi-Fixed/Vol. D8 Axial 30kB	36-10-280
7-VR5	EV322366	Semi-Fixed/Vol. D10 Axial 300kB	36-10-281
7-VR6,7	EV322416	Semi-Fixed/Vol. D8 Axial 30kB	36-10-280
7-VR8	EV315414	Semi-Fixed/Vol. D8 Axial 20kB	36-10-280
7-VR9	EV324396	Double-Axial 2-Throw/Vol. DM20R545A-50kAx2	36-18-21
7-RL1	EP308973	Relay LAB2NS DC24V	47-2-30
7-L1	EO321336	Vari. Inductor FE-002 10MH	23-1-333
7-L2	EO321295	Ferri Inductor RC875 4.7MH (J)	23-1-335
7-T1	EO323789	OSC Coil 53T116	23-4-57
7-FL1	ER309120	Dolby Filter D07-003	53-1-143
7-FL2	ER309119	Dolby Filter D07-001	53-1-143
7-FL3	EO315758	Trap Coil 100S-431	23-1-331
7-FL4	EO323790	Trap Coil 100S-821	23-1-404
7-J1	EJ323788	Pin Jack 4P	31-5-162
7-R30	ER301441	Metal Oxide Film/R. 2W 330 ohm (J)	35-15-8
7-R88,89	ER327441	Metal Oxide Film/R. F 1W 4.7 ohms (J)	35-19-1
7-R98	ER409814	Metal Oxide Film/R. 2W 220 ohm (K)	35-15-8
7-C4	EC305679	Styrol/C. 820PF(K) 50WV	24-11-14
7-C8	EC306986	Styrol/C. 220PF(K) 50WV	24-11-14
7-C9	EC307258	Styrol/C. 330PF(K) 50WV	24-11-14
7-C14	EC305677	Styrol/C. 200PF(K) 50WV	24-11-14
7-C41	EC321066	Solid Aluminum/C. 0.15μF(K) 25WV	24-19-3
7-C50,51	EC324272	Polypropylene/C. 0.0091μF(G) 100WV	24-22-12
7-C52	EC324274	Polypropylene/C. 0.0075μF(G) 100WV	24-22-12
7-C53	EC324275	Polypropylene/C. 0.0068μF(G) 100WV	24-22-12
7-C57	EC324402	Styrol/C. 1000PF(J) 500WV	24-11-17
7-C67,68	EC324005	Styrol/C. 680PF(K) 50WV	24-11-14
7-2	ZS356804	Set Screw, Hexagon Socket 3x4 (CUP/P.)	
7-3	ZS422076	Screw, pan 3x5	

8. BAR METER P.C BOARD (CE-5209) BLOCK

Symbol No.	Parts No.	Description	Schematic No.
8-IND1	EM315859	Bar Meter FIP48CW16YS	53-1-175
8-IC1,2	EI315799	IC HA12019	45-8-366

9. COUNTER P.C BOARD (UCF-6501) BLOCK

Symbol No.	Parts No.	Description	Schematic No.
9-IC1	EI323780	IC TC5054P	45-8-406
9-TR1to4	ET639437	Transistor 2SC945L(Q)(P)	45-1-85
9-IND1	ED324082	LED, 4 Figures 7 Segments SL-1406-20	59-2-1

10. MECHA P.C BOARD (UCF-1563) BLOCK

Symbol No.	Parts No.	Description	Schematic No.
10-L1,2	EO669273	Inductor FL5R-200	23-1-248
10-R1	ER320337	Cement/R. 5W 22 ohms(K)	35-16-80
10-C3	EC321068	NP/C. 47μF(M) 6.3WV	24-17-31

11. AMP CHASSIS BLOCK

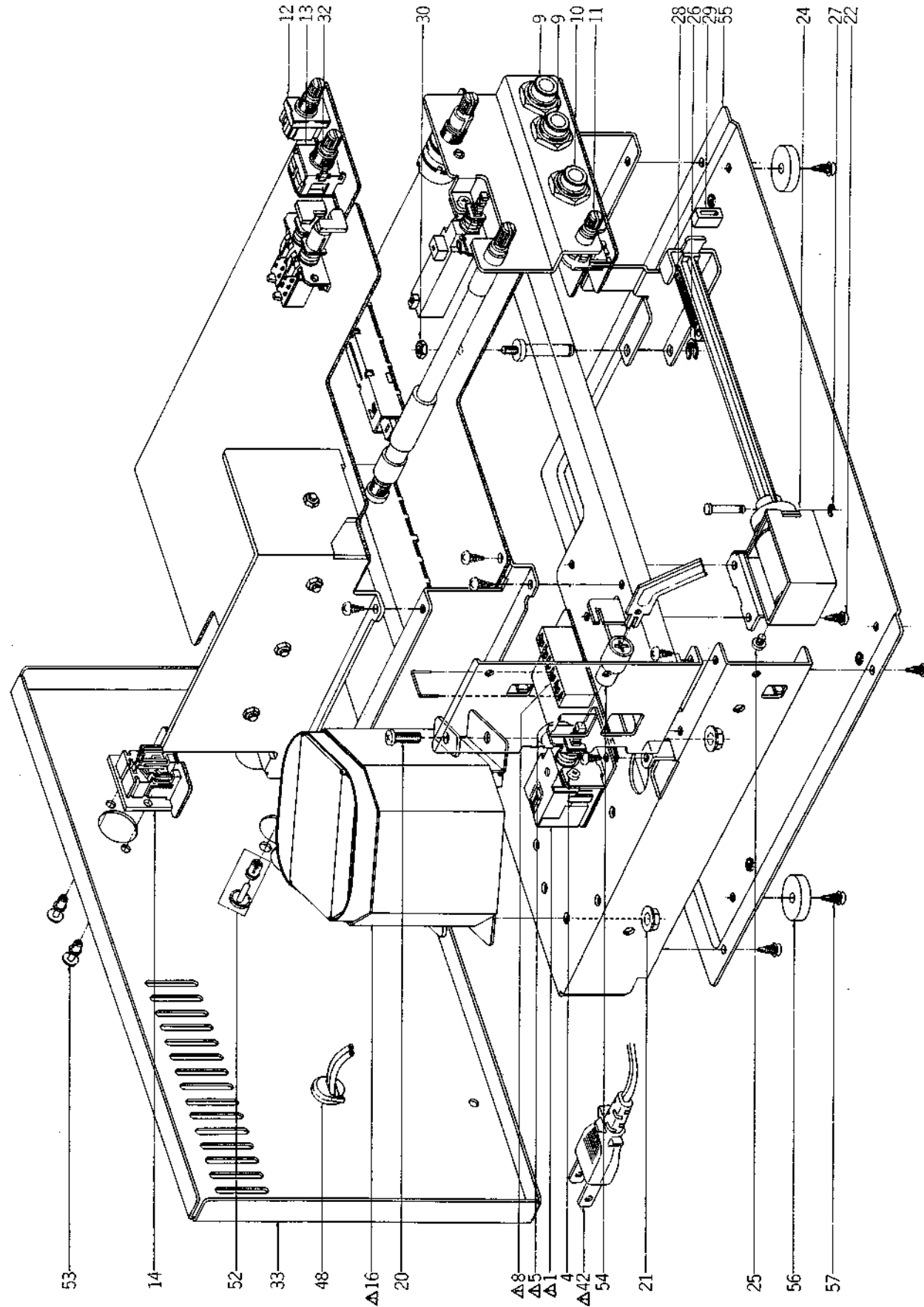

AMP CHASSIS BLOCK

Ref. No.	Parts No.	Description	Schematic No.	Ref. No.	Parts No.	Description	Schematic No.
POWER SW. P.C BOARD BLOCK							
11-1	ES665807	△ Push SW. SDG5P-E 5A/80A 250V (U/T,CEE,UK,SAA)	25-5-182	11-51x	ZS463353	Tapping Screw, #2 BR 3x8 (Black) (CEE,UK,SAA)	
11-2x	ES315159	△ Push SW. SDG1P (JPN)	25-5-330	11-52	ZW263946	Nylon Rivet 4x5	2-7-57
11-3x	ES665875	△ Push SW. SDG1P-J TV-3 UL/CSA (CSA,AAL)	25-5-199	11-53	ZW231030	Nylon Rivet (NRB) 3x4.5 (Black)	2-7-54
11-4	ZS422076	Screw, pan 3x5		FINAL ASSEMBLY BLOCK			
11-5	EC321302	△ Ceramic/C. E 0.01μF(Z) 250VAC (U/T,JPN)	24-5-90	11-54	TC289484	SW. Joint	CM-6015
11-6x	EC314688	△ Ceramic/C. DE7150 FZ 0.01μF(P) 125WV(CSA,AAL)	24-5-87	11-55	SP323769	Bottom Plate	UCF-5520
11-7x	EC327382	△ MP/C. (Vert.) 0.0047μF(M) 250WV (CEE,UK,SAA)	24-9-134	11-56	SA324129	Foot	UCF-5521
11-8	MZ283140	△ Voltage Changer 12M-60031 (U/T)	40-2-13	11-57	ZS490228	Tapping Screw, #2 bind 3x8	
JACK P.C BOARD BLOCK							
11-9	EJ321328	Jack HLJ0345-01-010	31-2-110				
11-10	EJ316156	Head Phone Jack HLJ0315-01-020	31-2-106				
11-11	EV324397	Single-Axial 2-Throw/Vol. GN20R522-10kBx2	36-7-17				
SW. P.C BOARD BLOCK							
11-12	ES324007	Rotary SW. SRU1023S	25-6-186				
11-13	ES324008	Rotary SW. SBU1024X01	25-6-187				
REMO. CON P.C BOARD BLOCK							
11-14	EJ324276	DIN Socket 8P TCS4680-01-111	31-5-156				
11-15x	ZS447840	Tapping Screw, #2 BR 3x8					
11-16	BT324069	△ Power Trans. UCFT-1(U/T)	38-4-768				
11-17x	BT324070	△ Power Trans. UCFT-2(JPN)	38-4-769				
11-18x	BT324071	△ Power Trans. UCFT-3 (CEE,UK,SAA)	38-4-770				
11-19x	BT324072	△ Power Trans. UCFT-4 (CSA,AAL)	38-4-771				
11-20	ZS413234	Screw, pan 4x12					
11-21	ZW413267	Flange Nut M4					
11-22	ZS325495	Tapping Screw, #2 BR 3x6					
11-23x	ER311503	Cement/R. (Wire Wounded) 10W 20 ohms (K)	35-16-89				
11-24	EP324395	Plunger 1037TLTI	44-1-132				
11-25	ZS324374	Screw, pan 3x3.5 (Blue)					
11-26	ZW290283	'U' Ring 2.85M	6-1-1				
11-27	ZW270088	'E' Ring 1.9M	6-1-9				
11-28	ZG313044	Coil Spring T1-5.0/0.55-22.4					
11-29	MB668801	Stopper Rubber TE (B)	TE-2039				
11-30	ZW516993	Nut, #1 M3					
11-31x	ZS306486	Tapping Screw, #2, BR 3x8 W/Washer					
11-32	MZ323757	SW. Joint	UCF-5514				
11-33	SP323760	Rear Panel (U/T)	UCF-5522				
11-34x	SP323766	Rear Panel (JPN)	UCF-5518				
11-35x	SP323762	Rear Panel (CSA)	UCF-5517				
11-36x	SP323765	Rear Panel (AAL)	UCF-5516				
11-37x	SP323767	Rear Panel (CEE,UK,SAA)	UCF-5519				
11-38x	SP323761	Rear Panel (U/T-BL)	UCF-5522				
11-39x	SP323764	Rear Panel (CSA-BL)	UCF-5517				
11-40x	SP323768	Rear Panel (CEE,UK,SAA-BL)	UCF-5519				
11-41	ZS447761	Tapping Screw, #2 BR 3x6 (Black)					
11-42	EW306428	△ AC Cord (U/T)	26-3-64				
11-43x	EW306427	△ AC Cord (JPN)	26-3-63				
11-44x	EW305691	△ AC Cord CUL (CSA,AAL)	26-3-65				
11-45x	EW315767	△ AC Cord Set CEE 2 Cores (CEE)	26-3-72				
11-46x	EW322400	△ AC Cord Set BASEC 2 Cores (UK)	26-3-73				
11-47x	EW322401	△ AC Cord Set SAA 2 Cores (SAA)	26-3-77				
11-48	EZ631945	Strain Relief SR-4N-4	2-7-49				
11-49x	EJ301513	△ Inlet 2P (CEE,UK,SAA)	31-1-200				
11-50x	ES306430	Slide SW. J-S4013 #01 (CEE,UK,SAA)	25-3-142				

When ordering parts, please quote Parts Number, Description and Model Number.

12. FRONT PANEL BLOCK

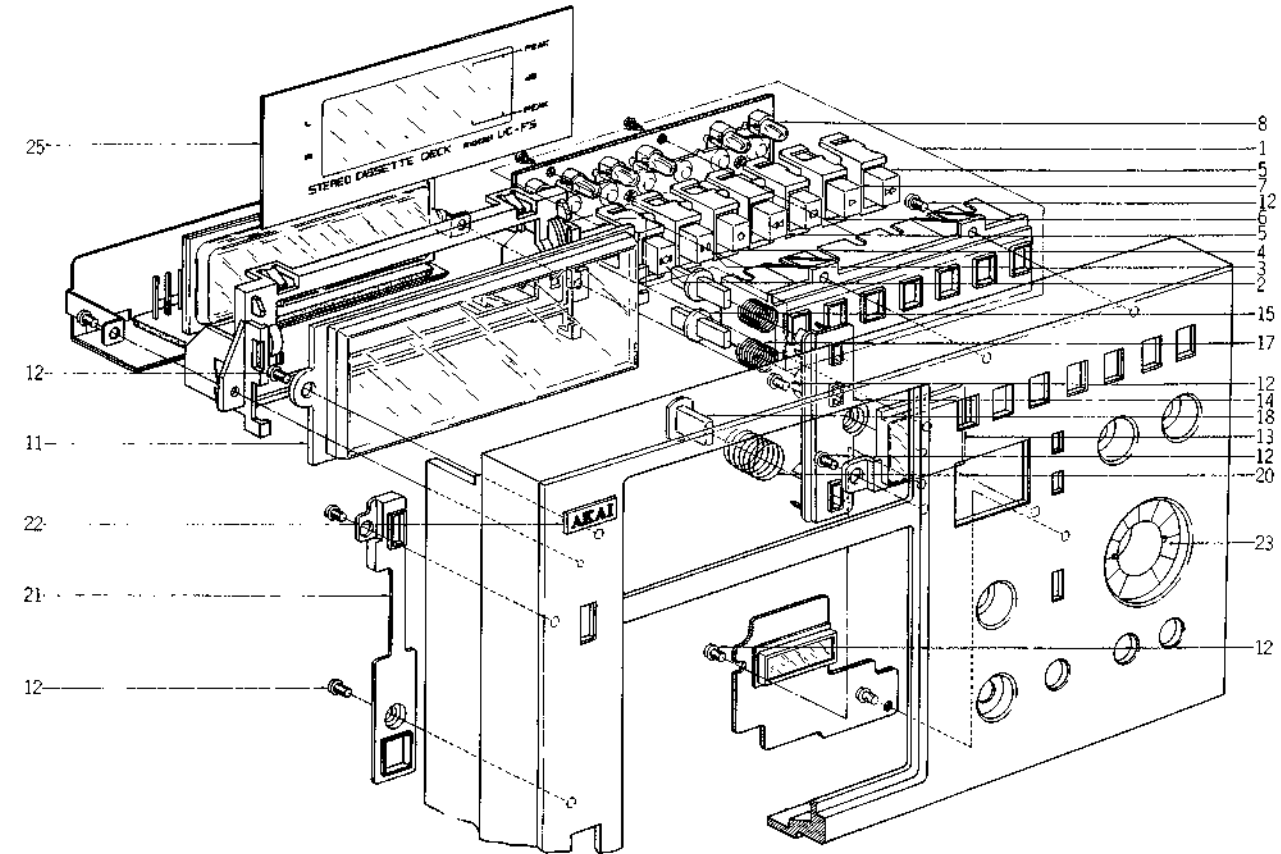

FRONT PANEL BLOCK

Ref. No.	Parts No.	Description	Schematic No.
OPERATION BLOCK			
12-1	BK324288	Operation BLK UC-F5	25-5-353
12-2	SB324279	Operation Button (REC MUTE)	25-5-353
12-3	SB324280	Operation Button (PAUSE)	25-5-353
12-4	SB324282	Operation Button (REC)	25-5-353
12-5	SB324283	Operation Button (FF, RWD)	25-5-353
12-6	SB324284	Operation Button (STOP)	25-5-353
12-7	SB324285	Operation Button (PLAY)	25-5-353
12-8	EL324286	Lamp 24V 500mA	25-5-353
FRONT PANEL BLOCK			
12-9x	BD323613	Front Panel BLK UC-F5	
12-10x	BD323614	Front Panel BLK UC-F5-BL	
12-11	SZ324032	Meter Window	UCF-6508
12-12	ZS379405	Screw, bind 3x6	
12-13	SZ324031	Counter Filter	UCF-6507, 6527
12-14	SE323777	SW. Escutcheon	UCF-6504
12-15	SB323778	Button (C)	UCF-6505
12-16x	SB323779	Button (C-BL)	UCF-6505
12-17	ZG494403	Return Spring	CG-1204
12-18	SB323309	Button (B)	UCA-5008
12-19x	SB323310	Button (B-BL)	UCA-5008
12-20	ZG323312	Spring (B)	UCA-5010
12-21	SE324030	Escutcheon	UCF-6506
12-22	SM323339	Name Plate	A0565
12-23	SZ324122	Decoration Ring	UCF-6512, 6513
12-24x	SZ324124	Decoration Ring (BL)	UCF-6512, 6513
12-25	SZ324035	Meter Filter	UCF-6510, 6511

When ordering parts, please quote Parts Number, Description and Model Number.

13. FINAL ASSEMBLY BLOCK

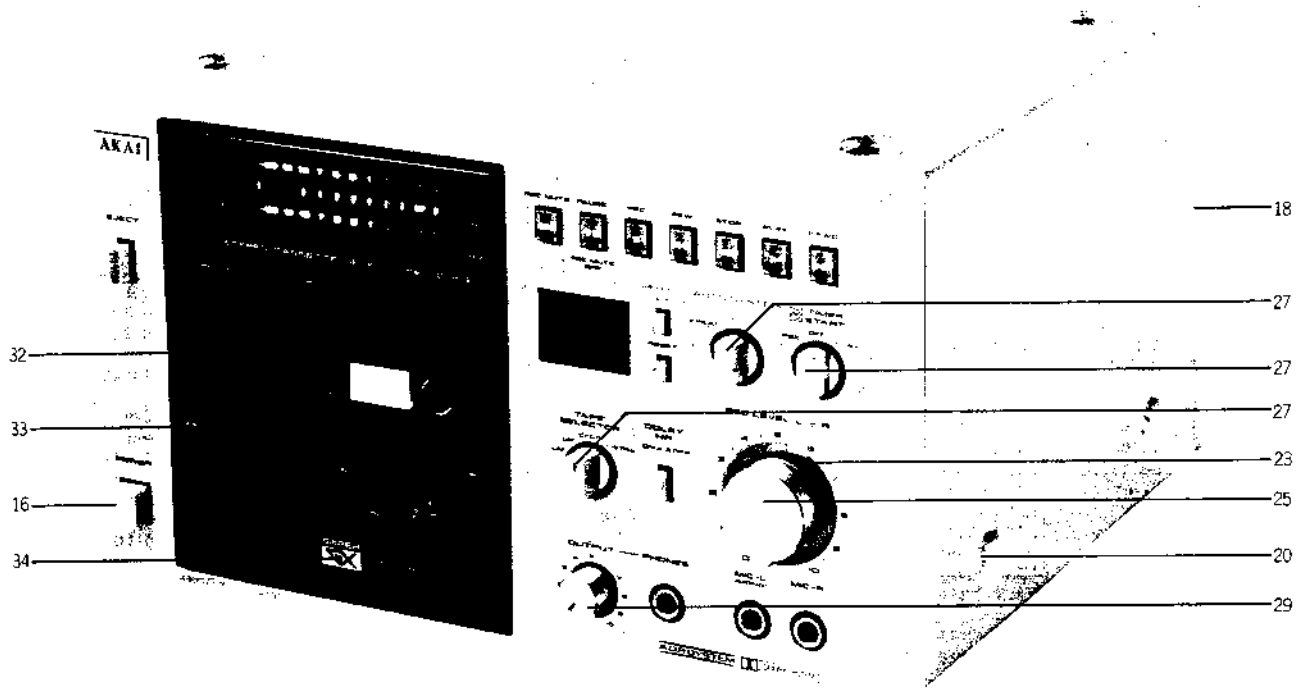

FINAL ASSEMBLY BLOCK

Ref. No.	Parts No.	Description	Schematic No.	Ref. No.	Parts No.	Description	Schematic No.
13-1x	ZS447840	Tapping Screw, #2 BR 3x8		13-18	BC324052	Upper Cover	UCF-6524
13-2x	ZS323728	Screw, bind 3x5		13-19x	BC324053	Upper Cover (BL)	UCF-6524
13-3x	ZS422076	Screw, pan 3x5		13-20	ZS315878	S-Tight Screw, bind 4x8	
13-4x	ZS558101	Screw, pan 3x6 W/Washer		13-21x	ZS310588	S-Tight Screw, bind 4x8	
13-5x	ZS325495	Tapping Screw, #2 BR 3x6				(Black)	
13-6x	EF593706	△ Fuse (SEMKO T) 500MAT (CEE,UK,SAA)	39-1-53	13-22x	ZS463353	Tapping Screw, #2 BR 3x8 (Black)	
13-7x	EF306949	△ Fuse 1.25A 250V (U/T, JPN)	39-1-64	13-23	SK323704	Double Knob (Lower-A) UC-F5	UCF-6520
13-8x	EF306950	△ Fuse 2A 250V (U/T, JPN)	39-1-64	13-24x	SK324047	Double Knob (Lower-A-BL) Part UC-F5-BL	UCF-6520
13-9x	EF309389	△ Fuse 400mA 250V (U/T, JPN)	39-1-64	13-25	SK324210	Double Knob (Upper) Part UC-F5	UCF-6521
13-10x	EF309392	△ Fuse 1.25A 125V (CSA, AAL)	39-1-65	13-26x	SK324211	Double Knob (Upper-BL) Part UC-F5-BL	UCF-6521
13-11x	EF306954	△ Fuse 2A 125V (CSA, AAL)	39-1-65	13-27	SK323770	Knob (A) Part UC-F5	UCF-6522
13-12x	EF308848	△ Fuse 400mA 125V (CSA, AAL)	39-1-65	13-28x	SK324290	Knob (A-BL) Part UC-F5-BL	UCF-6522
13-13x	EF623103	△ Fuse (SEMKO T) 1AT (CEE,UK,SAA)	39-1-53	13-29	SK324291	Knob (B) Part UC-F5	UCF-6523
13-14x	EF601301	△ Fuse (SEMKO T) 2AT (CEE,UK,SAA)	39-1-53	13-30x	SK324293	Knob (B-BL) Part UC-F5-BL	UCF-6523
13-15x	EF300590	△ Fuse (EAWK) 400MAT (CEE,UK,SAA)	39-1-60	13-31x	SZ324041	Lid Panel	UCF-6516, 6517
13-16	SB324039	Button (B)	UCF-6515	13-32	SZ324042	Lid Window	UCF-6518
13-17x	SB324040	Button (B-BL)	UCF-6515	13-33	ZS324043	Decoration Screw	UCF-6519
				13-34	SM315737	Super GX Name Plate	CF-6236
				13-35x	ZW305013	Pop Rivet D3.2	7-6-9

INDEX

Parts No.	Ref. No. & Symbol No.	Parts No.	Ref. No. & Symbol No.	Parts No.	Ref. No. & Symbol No.	Parts No.	Ref. No. & Symbol No.	Parts No.	Ref. No. & Symbol No.
BA323658	7-1	ED560913	7-D2	ET313514	6-TR1	SK324047	13-24x	ZS419782	2-11
BA324093	6-1	ED560913	7-D5to10	ET315958	6-TR28,29	SK324210	13-25	ZS421806	6-4
BA324094	6-2	ED624903	6-D74	ET327714	6-TR40	SK324211	13-26x	ZS422076	4-5
BA324095	6-3	EF300590	13-15x	ET554657	6-TR7	SK324290	13-28x	ZS422076	5-3
BC324052	13-18	EF306949	13-7x	ET554657	6-TR25	SK324291	13-29	ZS422076	7-3
BC324053	13-19x	EF306950	13-8x	ET554657	6-TR60	SK324293	13-30x	ZS422076	11-4
BD323613	12-9x	EF306954	13-11x	ET603257	7-TR2	SM315737	13-34	ZS422076	13-3x
BD323614	12-10x	EF308848	13-12x	ET639437	6-TR8to23	SM323339	12-22	ZS430413	3-2
BF324381	4-48	EF309389	13-9x	ET639437	6-TR32,33	SP323760	11-33	ZS447761	11-41
BH323630	2-1x	EF309392	13-10x	ET639437	6-TR38	SP323761	11-38x	ZS447840	4-28
BK324288	12-1	EF593706	13-6x	ET639437	6-TR44to49	SP323762	11-35x	ZS447840	11-15x
BL326857	4-38	EF601301	13-14x	ET639437	6-TR55to59	SP323764	11-39x	ZS447840	13-1x
BM323629	3-1	EF623103	13-13x	ET639437	6-TR61,62	SP323765	11-36x	ZS462947	2-9
BM324427	4-1	EI306141	7-IC2	ET639437	6-TR31to8	SP323766	11-34x	ZS463353	11-51x
BT324069	11-16	EI308936	6-IC1	ET639437	7-TR10,11	SP323767	11-37x	ZS463353	13-22x
BT324070	11-17x	EI315799	8-IC1,2	ET639437	7-TR15	SP323768	11-40x	ZS464692	2-13
BT324071	11-18x	EI316170	6-IC7	ET639437	9-TR1to4	SP323769	11-55	ZS464703	4-37
BT324072	11-19x	EI322490	6-IC4to6	ET666404	6-TR24	SZ324031	12-13	ZS477876	4-24
BZ323633	5-1	EI323780	9-IC1	ET666404	6-TR26,27	SZ324032	12-11	ZS479474	4-9
EC305677	7-C14	EI324061	4-11	ET666404	6-TR30	SZ324035	12-25	ZS490228	11-57
EC305679	7-C4	EI605013	7-IC1	ET666404	6-TR42	SZ324041	13-31x	ZS524812	2-6
EC306986	7-C8	EI633982	6-IC2,3	ET666415	6-TR35	SZ324042	13-32	ZS537085	4-13
EC307258	7-C9	EJ301513	11-49x	ET666415	6-TR52	SZ324122	12-23	ZS558101	13-4x
EC308940	6-C25,26	EJ316156	11-10	EV306737	7-VR2	SZ324124	12-24x	ZS590804	2-8
EC314688	11-6x	EJ321328	11-9	EV315412	7-VR3	TC289484	11-54	ZS592378	3-14
EC315964	6-C1	EJ323788	7-J1	EV315414	7-VR8	TC309145	4-8	ZS608095	4-35
EC315966	6-C6	EJ324276	11-14	EV321682	6-VR2	TC309206	5-8	ZS608185	5-10
EC315968	6-C8	EL317599	4-34	EV322366	7-VR5	TC317433	3-16	ZS609074	4-12x
EC316184	6-C12	EL324286	12-8	EV322416	7-VR4	TC317454	5-7	ZW231030	11-53
EC316230	6-C9	EM315859	8-IND1	EV322416	7-VR6,7	TC317455	5-11	ZW263946	11-52
EC321066	7-C41	EO315758	7-FL3	EV324366	7-VR1	TC323621	4-10	ZW270088	3-3
EC321068	10-C3	EO321295	7-L2	EV324396	7-VR9	TC323627	3-22	ZW270088	4-19
EC321302	11-5	EO321336	7-L1	EV324397	11-11	TC323725	2-16	ZW270088	5-14
EC324005	7-C67,68	EO323789	7-T1	EW305691	11-44x	TC324289	4-40	ZW270088	11-27
EC324076	6-C52,53	EO323790	7-FL4	EW306427	11-43x	TC324298	5-4	ZW270101	4-22
EC324272	7-C50,51	EO669273	10-L1,2	EW306428	11-42	TC324401	4-47	ZW273756	6-5
EC324274	7-C52	EP308973	7-RL1	EW315767	11-45x	ZG289236	2-2	ZW290283	3-15
EC324275	7-C53	EP313497	3-13	EW322400	11-46x	ZG309225	3-5	ZW290283	4-21
EC324402	7-C57	EP324062	4-23	EW322401	11-47x	ZG309226	3-7	ZW290283	11-26
EC327382	11-7x	EP324278	4-17	EZ631945	11-48	ZG312964	4-46	ZW305013	13-35x
ED306109	6-D2	EP324395	11-24	HE321585	2-12	ZG312999	5-18	ZW309295	4-49
ED306109	6-D7	ER301441	7-R30	HP319079	2-5	ZG313001	3-23	ZW321437	4-14
ED306109	6-D41	ER309119	7-FL2	HZ309128	2-3	ZG313044	11-28	ZW322525	4-43
ED306109	6-D59	ER309120	7-FL1	MB282104	3-6	ZG313165	5-9	ZW322525	5-15
ED306109	6-D62	ER311503	11-23x	MB282778	4-2	ZG322048	3-11	ZW322912	3-19
ED308952	6-D3	ER312487	6-R1	MB282778	5-2	ZG323312	12-20	ZW323734	4-44
ED308952	6-D21to30	ER319177	6-R6	MB323681	4-50	ZG323699	4-31	ZW356657	4-25
ED308952	6-D57	ER320337	10-R1	MB323686	4-16	ZG323702	4-45	ZW357164	5-13
ED308952	6-D68	ER324081	6-R85	MB668801	11-29	ZG323714	4-39	ZW381644	3-18
ED308952	7-D1	ER327441	7-R88,89	MH323720	5-5	ZG323715	2-15	ZW413267	11-21
ED308952	7-D3,4	ER409814	7-R98	MI309414	3-12	ZG323736	3-17	ZW432753	3-10
ED309069	6-D5	ES306430	11-50x	ML309229	3-8	ZG324400	4-42	ZW516993	11-30
ED309069	6-D31	ES312050	7-SW1	MR323683	4-15	ZG365433	3-4	ZW563218	6-6
ED309357	6-D1	ES315159	11-2x	MR323722	5-12	ZG370350	4-26	ZW589893	5-17x
ED309357	6-D4	ES323786	7-SW2	MS309141	4-6	ZG465636	2-10	ZW590207	4-7
ED313513	6-SCR1	ES324007	11-12	MT305793	3-21	ZG469315	3-9	ZW590207	5-6
ED313623	6-D8	ES324008	11-13	MT312122	3-20	ZG494403	12-17	ZW591265	2-4
ED315960	6-D6	ES324009	6-SW1-2	MV269965	4-29	ZG595506	3-25	ZW649991	5-16x
ED316143	6-D18	ES324063	4-36	MV309146	4-30	ZS267254	2-17		
ED316143	6-D42	ES324271	7-SW3	MZ283140	11-8	ZS302318	4-4		
ED316143	6-D72	ES665807	11-1	MZ323757	11-32	ZS306486	11-31x		
ED317594	6-D15	ES665875	11-3x	SA324129	11-56	ZS310588	13-21x		
ED317594	6-D55	ET301464	7-TR9	SB323309	12-18	ZS315878	13-20		
ED319176	6-D32	ET305463	6-TR3	SB323310	12-19x	ZS318208	4-41		
ED319176	6-D71	ET307349	6-TR31	SB323696	4-32	ZS321338	4-3		
ED324013	6-D9	ET307349	7-TR14	SB323697	4-33x	ZS323728	4-20		
ED324082	9-IND1	ET308937	6-TR2	SB323778	12-15	ZS323728	13-2x		
ED326139	6-D73	ET308937	6-TR34	SB323779	12-16x	ZS324043	13-33		
ED560913	6-D10to14	ET308937	6-TR36	SB324039	13-16	ZS324374	4-18		
ED560913	6-D16,17	ET308937	6-TR39	SB324040	13-17x	ZS324374	11-25		
ED560913	6-D19,20	ET308937	6-TR41	SB324279	12-2	ZS325495	4-27		
ED560913	6-D33to40	ET308937	6-TR51	SB324280	12-3	ZS325495	11-22		
ED560913	6-D43to46	ET308937	6-TR53	SB324282	12-4	ZS325495	13-5x		
ED560913	6-D48to54	ET308977	7-TR12,13	SB324283	12-5	ZS356804	2-7		
ED560913	6-D56	ET309353	6-TR37	SB324284	12-6	ZS356804	7-2		
ED560913	6-D58	ET309353	6-TR50	SB324285	12-7	ZS379350	6-7		
ED560913	6-D60,61	ET309353	6-TR54	SE323777	12-14	ZS379405	12-12		
ED560913	6-D63to67	ET311832	7-TR1	SE324030	12-21	ZS413234	11-20		
ED560913	6-D69,70	ET312497	6-TR4to6	SK323704	13-23	ZS417161	2-14		
ED560913	6-D75,76	ET312497	6-TR43	SK323770	13-27	ZS417216	3-24		

SCHEMATIC DIAGRAM

1. SCHEMATIC DIAGRAM OF ICs
2. UC-F5 NO. 2-1 1600630A SCHEMATIC DIAGRAM
3. UC-F5 AMP NO. 2-2 1600631A SCHEMATIC DIAGRAM

HA12019

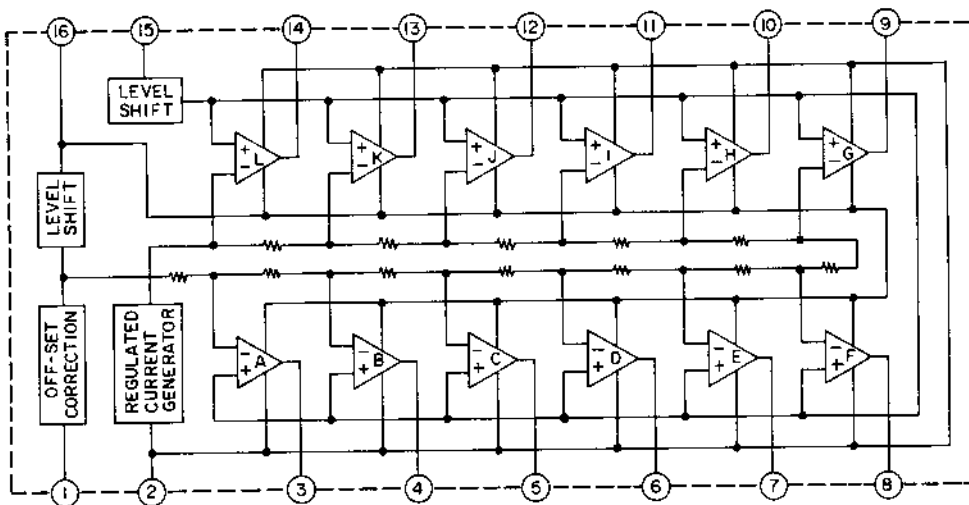

LA4170

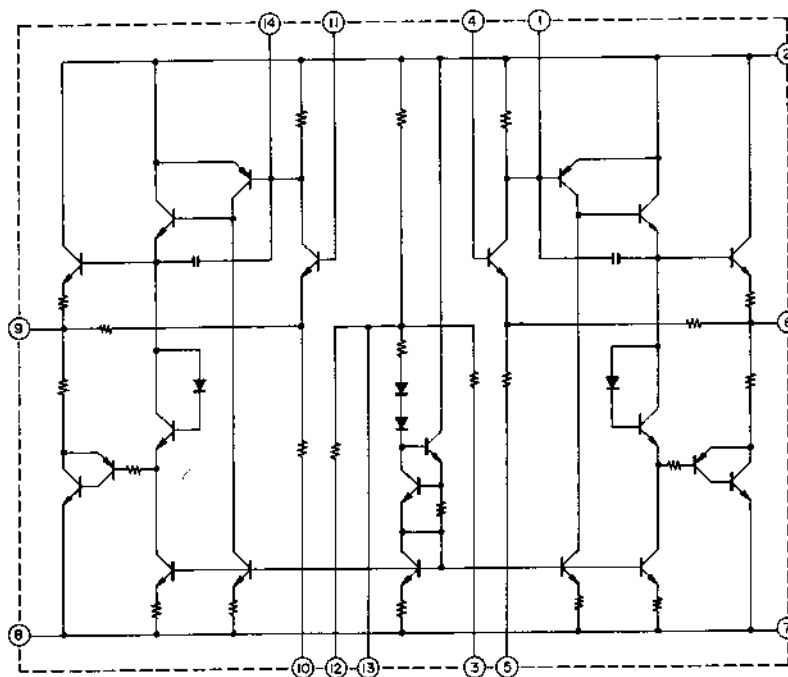

LB1270

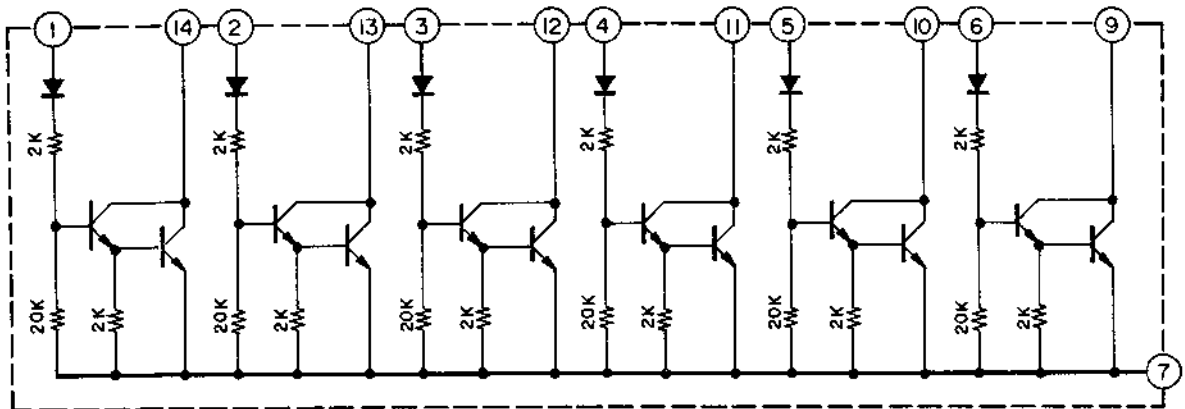

M53200P

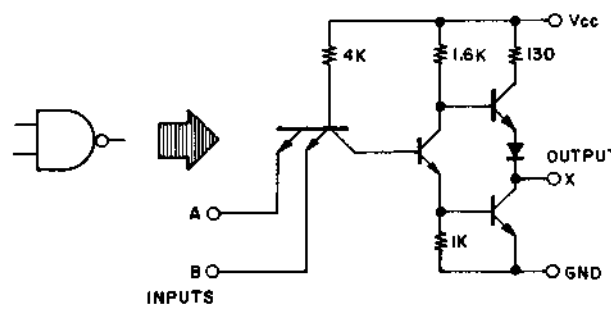
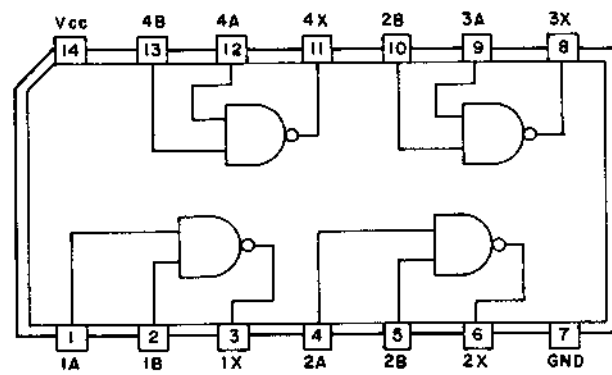

M54410P

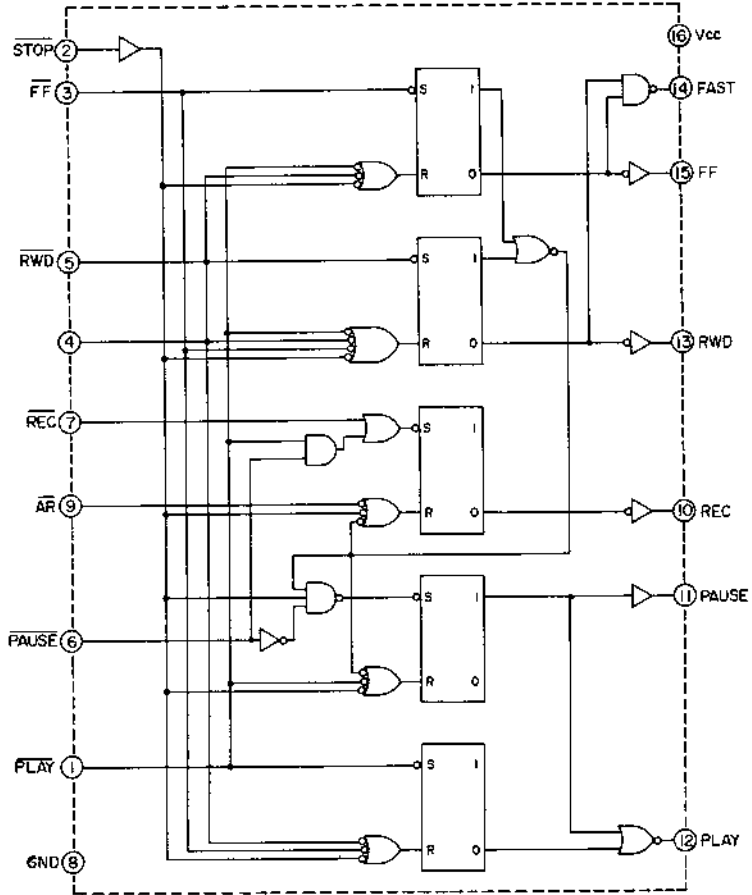

NE545B

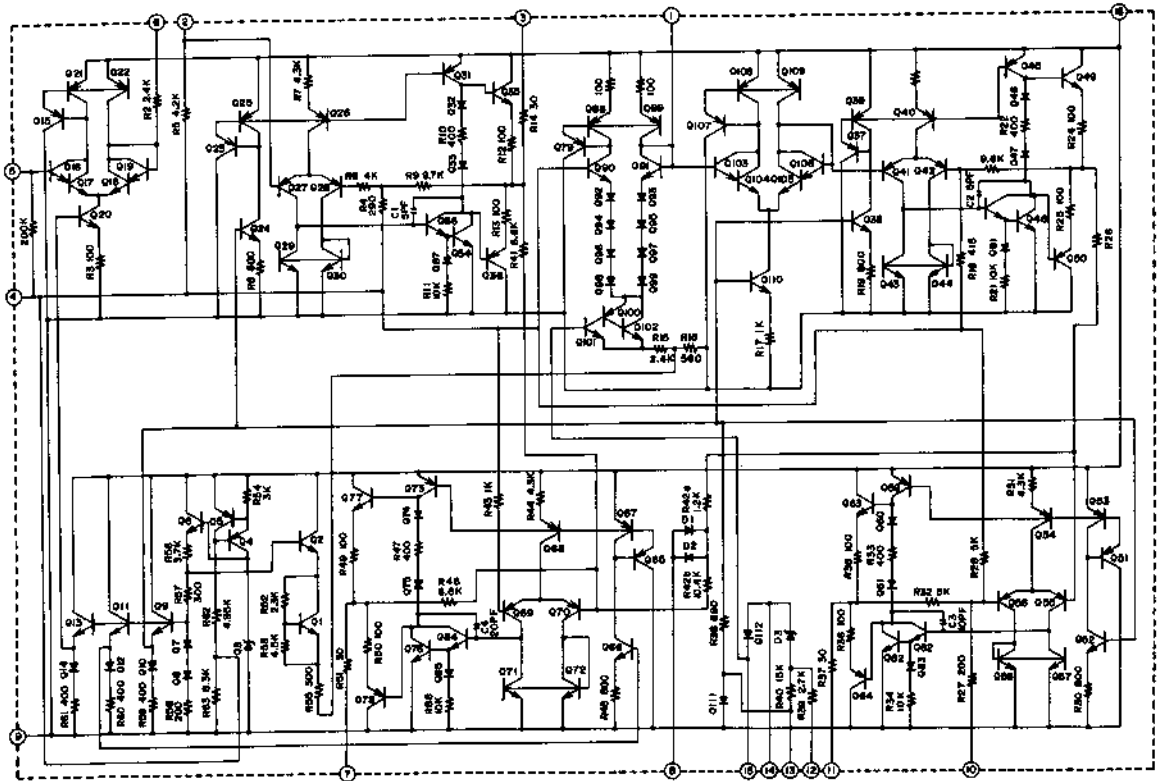

SN7401N

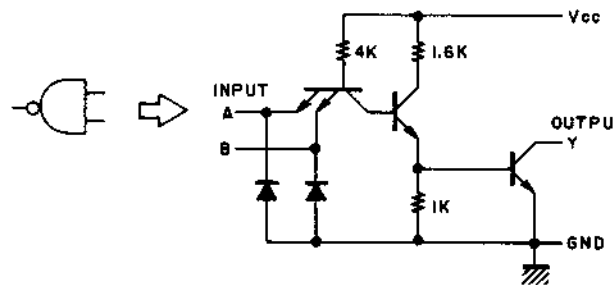
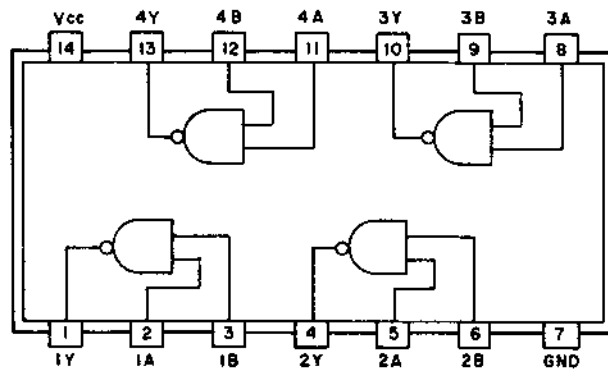

TC5054P

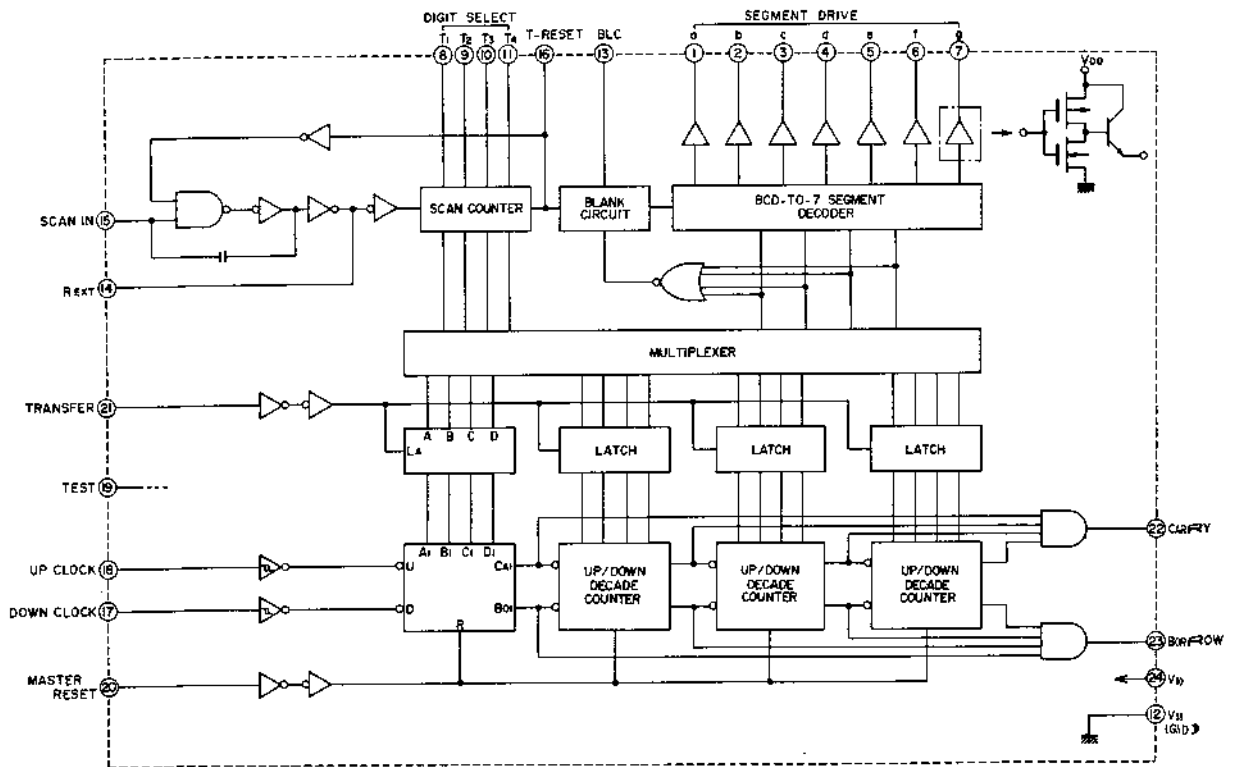

UC-F5

WARNING: Δ INDICATES SAFETY CRITICAL COMPONENTS FOR CONTINUED SAFETY. REPLACE SAFETY CRITICAL COMPONENTS ONLY WITH MANUFACTURER'S RECOMMENDED PARTS.
 AVERTISSEMENT: Δ IL INDIQUE LES COMPOSANTS CRITIQUES DE SÛRETÉ. POUR MAINTENIR LE DEGRÉ DE SÛRETÉ DE L'APPAREIL, NE REMPLACER LES COMPOSANTS DONT LE FONCTIONNEMENT EST CRITIQUE POUR LA SÛRETÉ QUE PAR DES PIÈCES RECOMMANDÉES PAR LE FABRICANT.

U/T

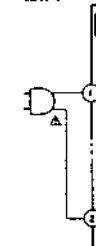

POWER SWITCH P.C. BOARD UCF-5503

CEE UK, SAA

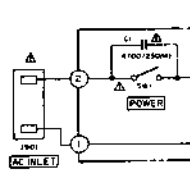

JPN CSA, AAL

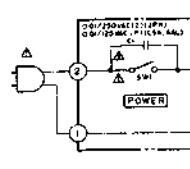

U	F2	F3	F4	F5
U/T	1.25A 250V	1.25A 250V	2A 250V	400mA 250V
CEE UK, SAA	7.5A	7.5A	7.5A	1A 250V
JPN	1.25A 250V	1.25A 250V	2A 250V	400mA 250V
CSA, AAL	1.25A 250V	1.25A 250V	2A 250V	400mA 250V

CAPSTAR MOTOR

REFLECTOR P.C. BOARD UCF-1550

DETECTOR P.C. BOARD UCF-1520

MECHA P.C. BOARD UCF-1563

REMOTE CONTROL P.C. BOARD UCF-5502C

SWITCH P.C. BOARD 1/2 UCF-5502B

SYS CON P.C. BOARD UCF-5502A

COUNTER P.C. BOARD UCF-6501

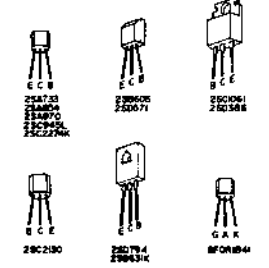

NOTE: UNLESS OTHERWISE SPECIFIED ALL RESISTORS IN OHMS (AWL) ALL CAPACITORS IN μF (50WV) (P) = POLAR. SAFE RESISTORS (P) = NON-POLAR. CAPACITORS POWER TRANSFORMER IS DIFFERENT ACCORDING TO AREA

UC-F5
 SCHEMATIC DIAGRAM
 NO.2-1 1600630A

UC-F5

METER PC BOARD CE-5209

JACK PC BOARD 1/2
UCF-5501B

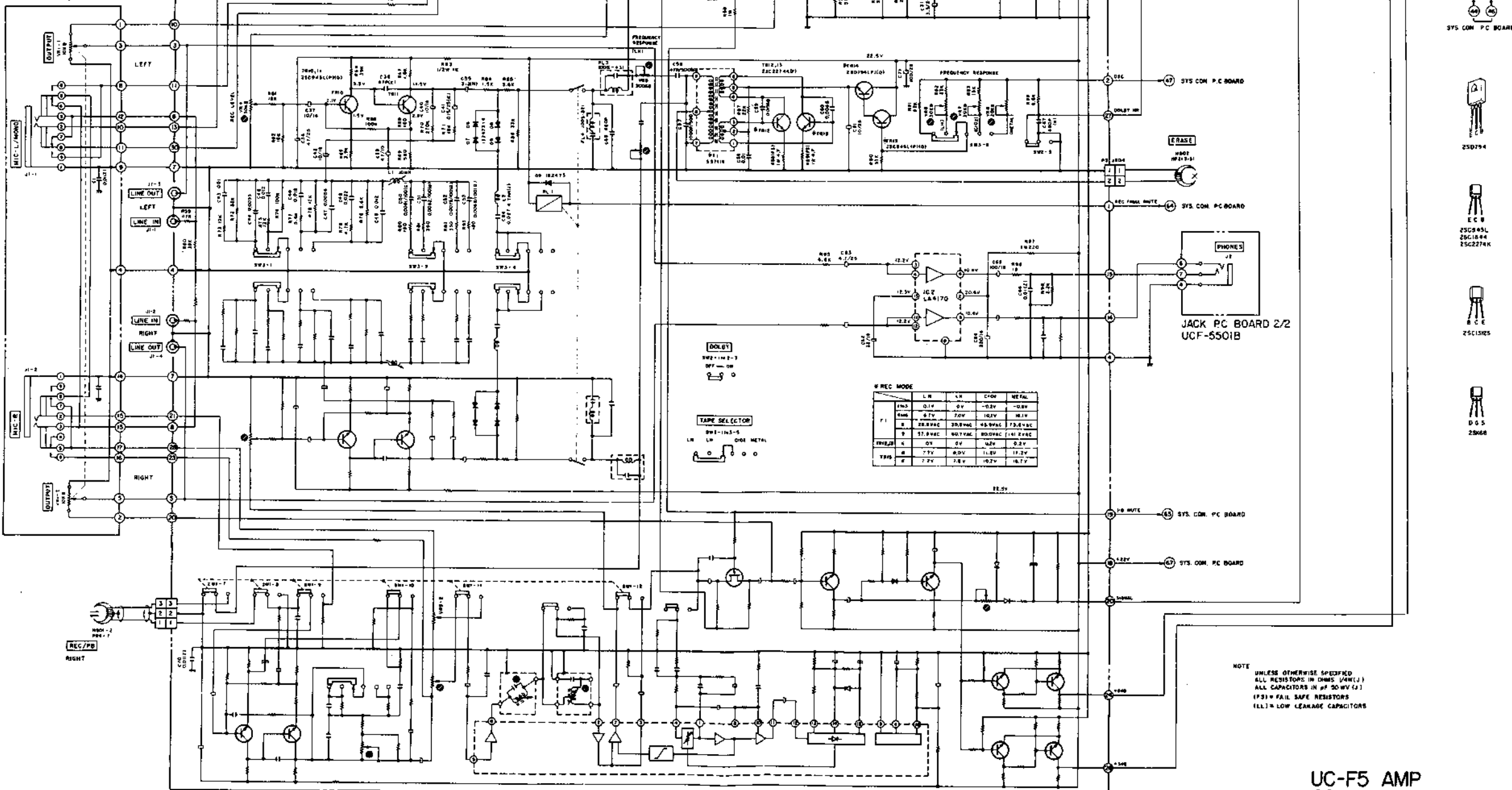

PRE AMP PC BOARD UCF-5501A

NOTE
 UNLESS OTHERWISE SPECIFIED
 ALL RESISTORS IN OHMS (WHERE
 ALL CAPACITORS IN P.F. OR MFD.)
 (F5) = FAIL SAFE RESISTORS
 (LL) = LOW LEAKAGE CAPACITORS

UC-F5 AMP
 SCHEMATIC DIAGRAM
 NO. 2-2 1600631A

COMPOSITION OF VARIOUS P.C BOARDS

Sys. Con P.C Board UCF-5502A (3ED), Switch P.C Board UCF-5502B and Remote Control P.C Board UCF-5502C

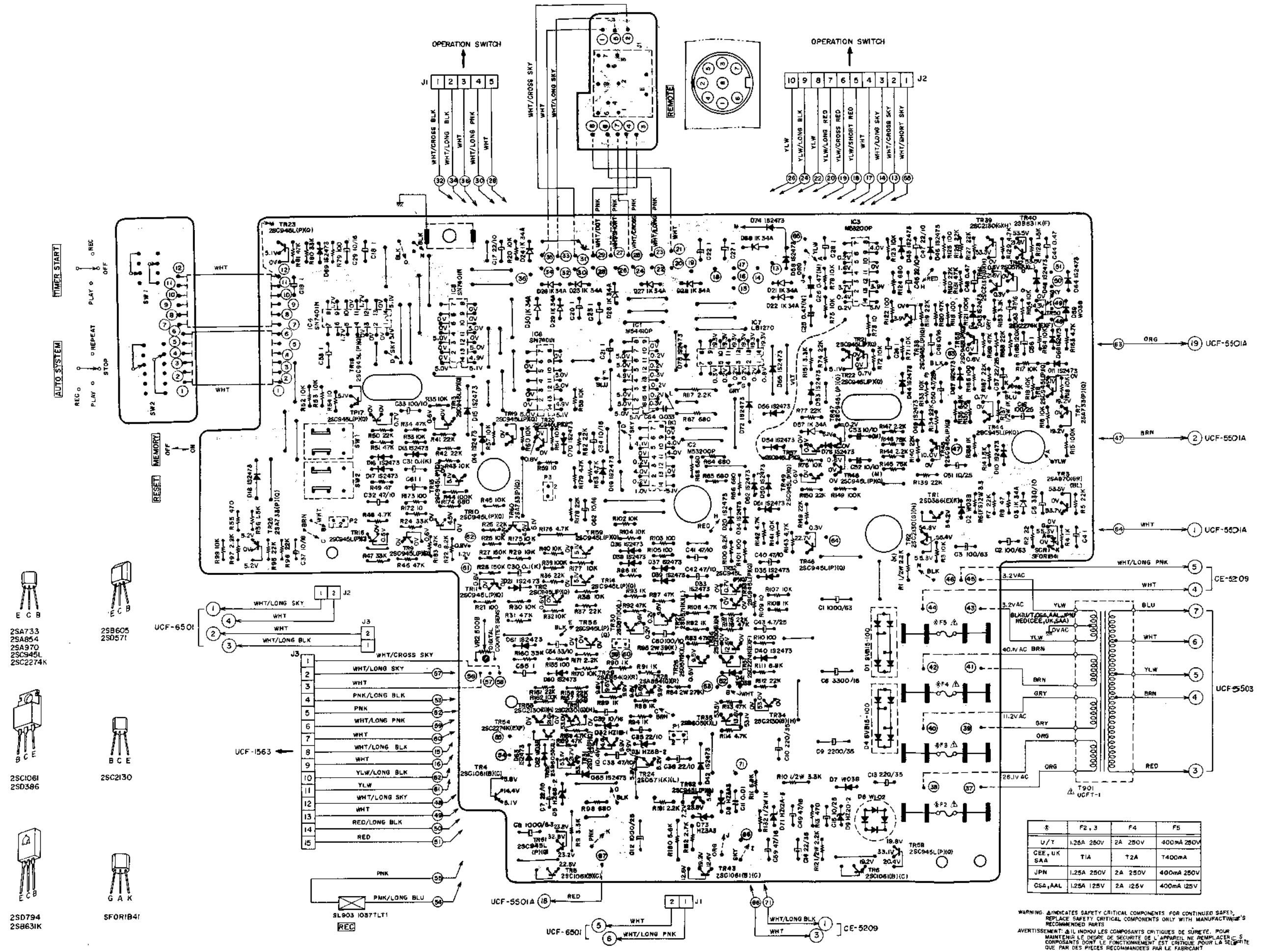

Pre Amp P.C Board UCF-5501A (2ED)

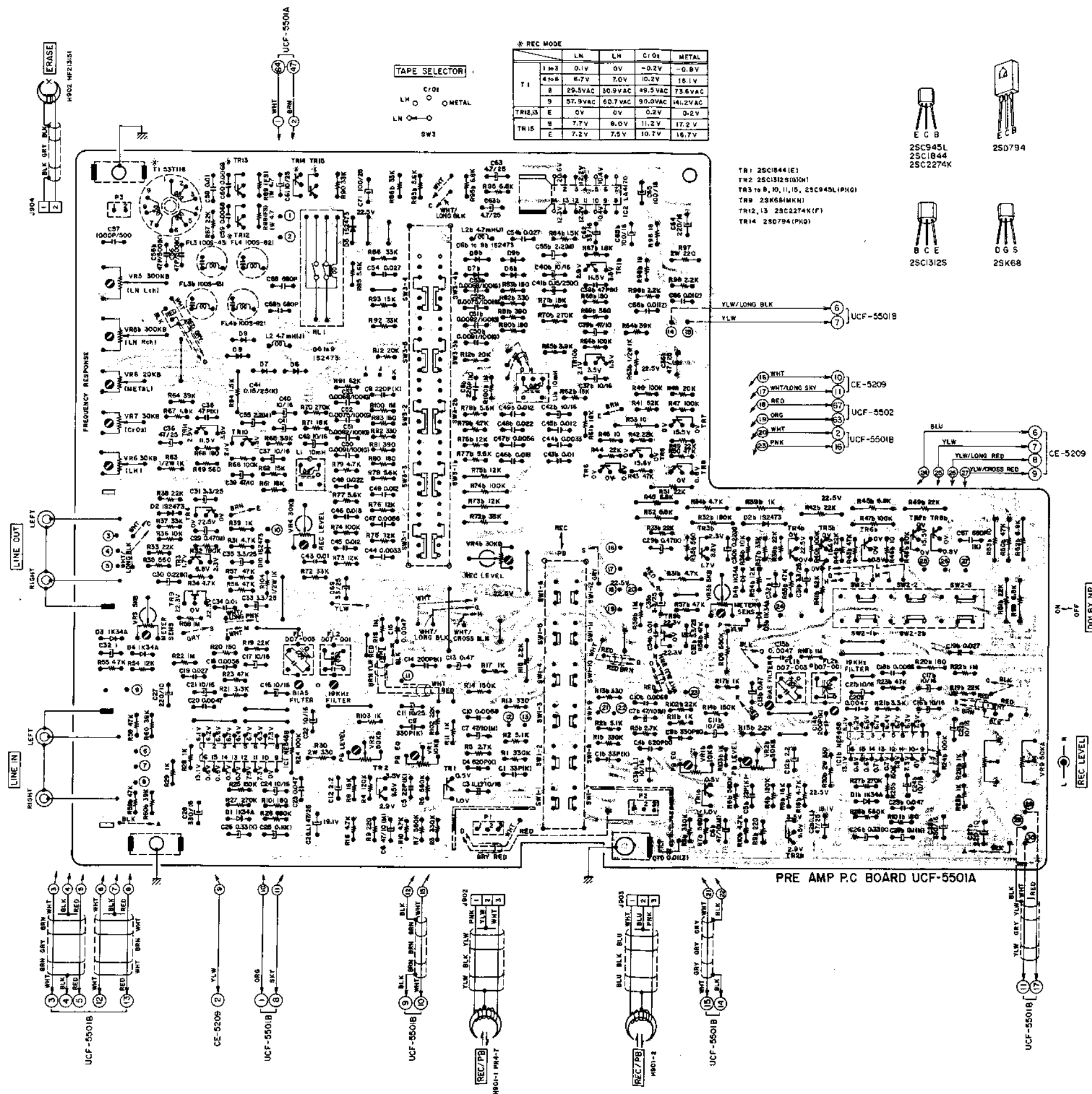

REC MODE

	LN	LH	CI OI	METAL
1 to 3	0.1V	0V	-0.2V	-0.8V
4 to 6	6.7V	7.0V	10.2V	15.1V
8	29.5VAC	30.9VAC	49.5VAC	73.6VAC
9	57.9VAC	60.7VAC	90.0VAC	141.2VAC
TR12,13	0V	0V	0.2V	0.2V
TR15	7.7V	8.0V	11.2V	17.2V
	7.2V	7.5V	10.7V	16.7V

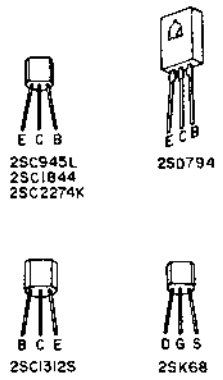

- TR1 25C1844(E)
- TR2 25C1312S(01M)
- TR3 to 8, 10, 11, 15, 25C945L(PH0)
- TR9 25K68(MKN)
- TR12, 13 25C2274K(F)
- TR14 25079A(PH0)

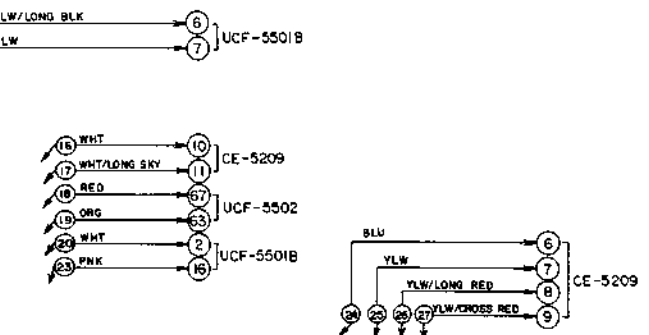

PRE AMP P.C BOARD UCF-5501A

Meter P.C Board CE-5209

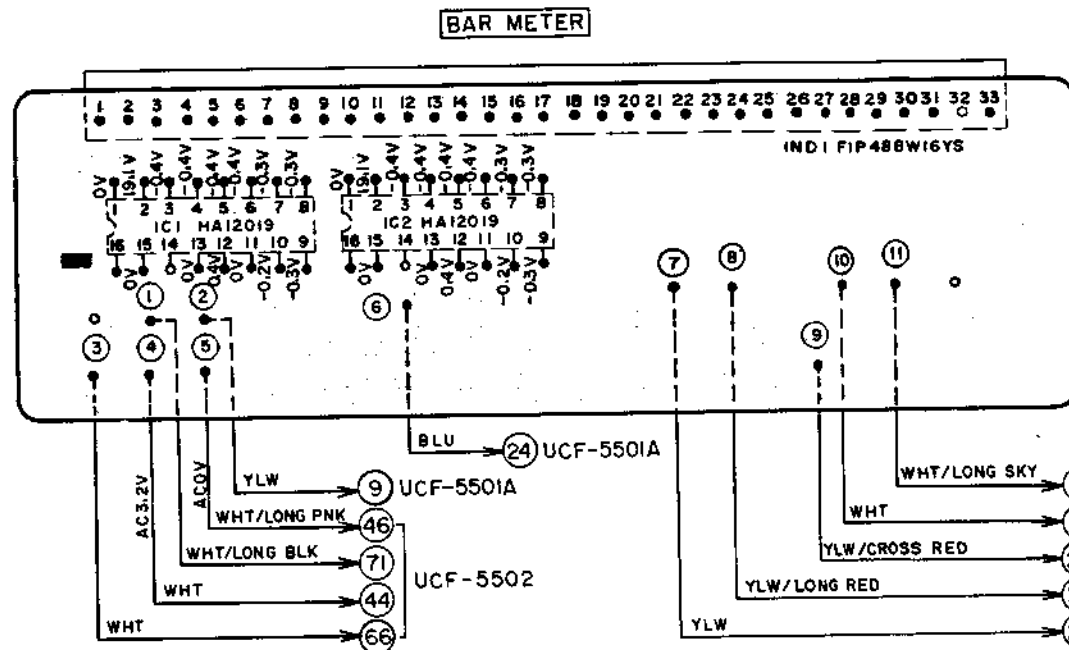

Counter P.C Board UCF-6501

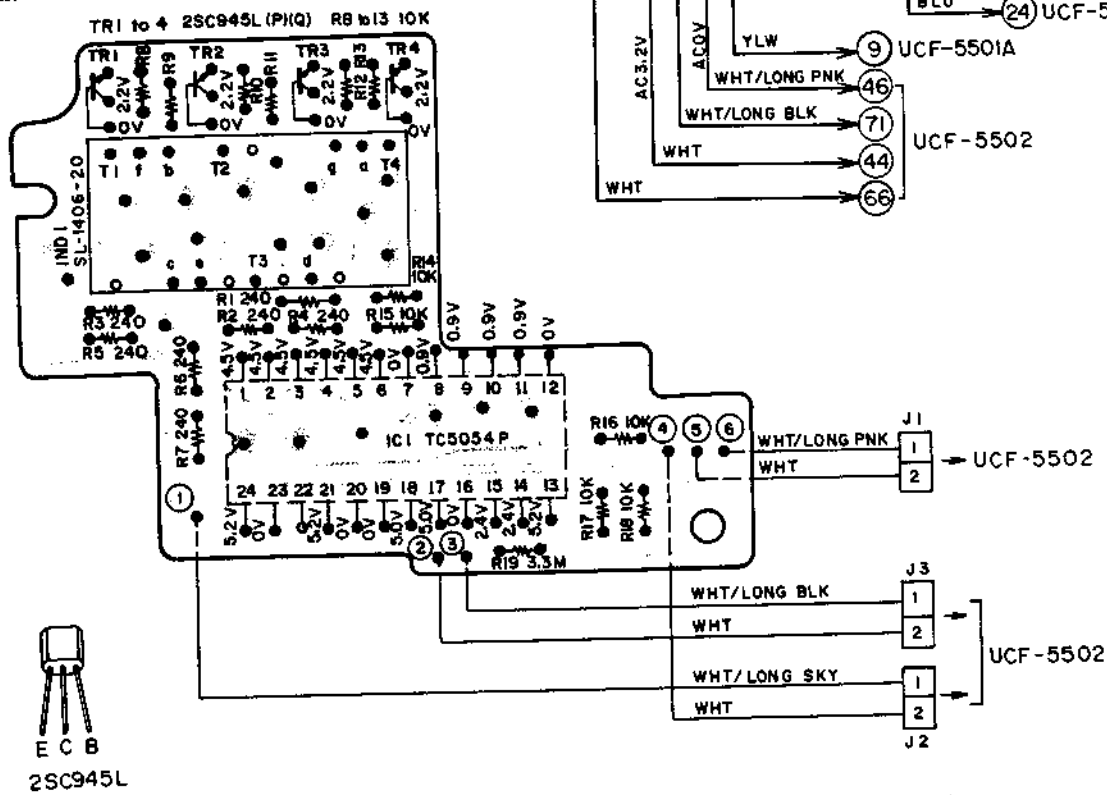

Mecha P.C Board UCF-1563 (3ED), Reflector P.C Board UCF-1550 and Detector P.C Board UCF-1520

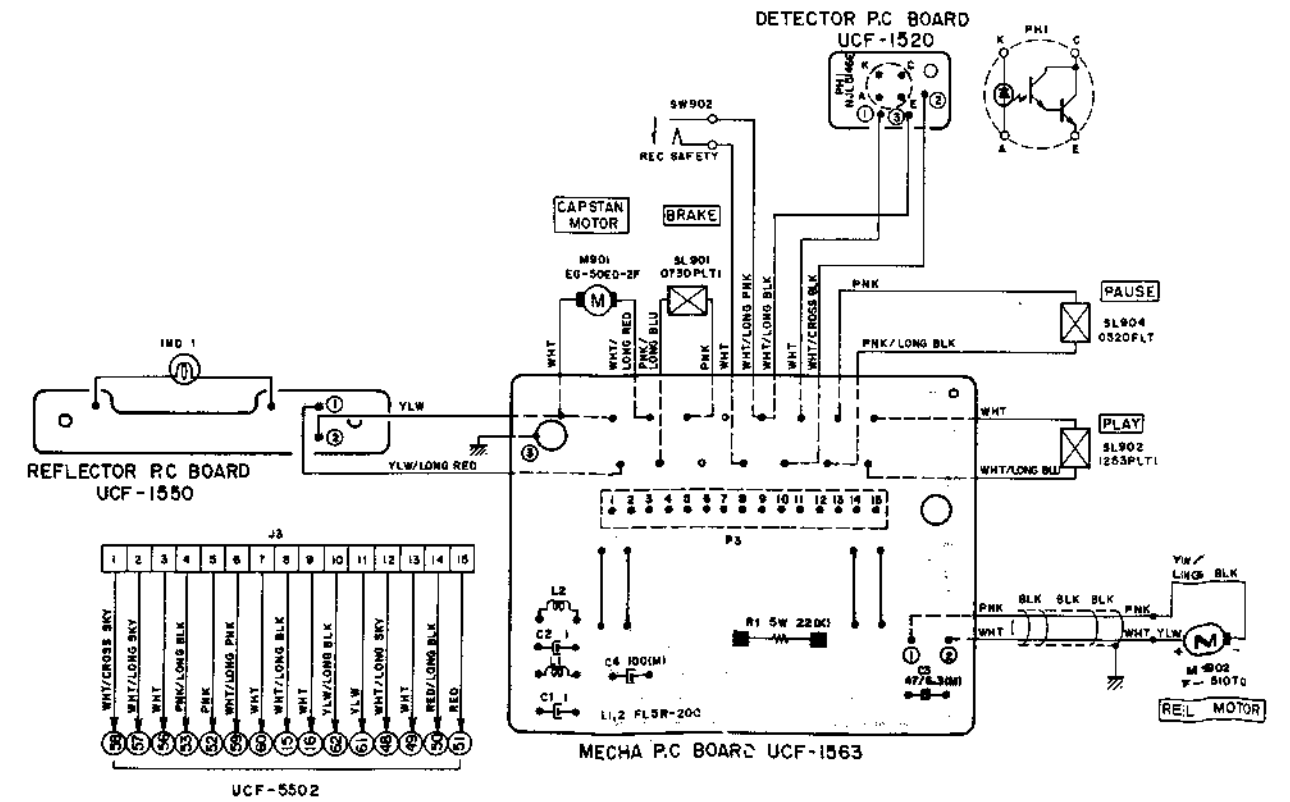

WARNING: INDICATED SAFETY CRITICAL COMPONENTS FOR CONTINUED SAFETY. REPLACE SAFETY CRITICAL COMPONENTS ONLY WITH MANUFACTURER'S RECOMMENDED PARTS.
 AVERTISSEMENT: IL INDIQUE LES COMPOSANTS CRITIQUES DE SURETE POUR MAINTENIR LE DEGRE DE SURETE DE L'APPAREIL. NE REMPLACER LES COMPOSANTS DONT LE FONCTIONNEMENT EST CRITIQUE POUR LA SECURITE QUE PAR DES PIECES RECOMMANDEES PAR LE FABRICANT.

