

AKAI SERVICE MANUAL

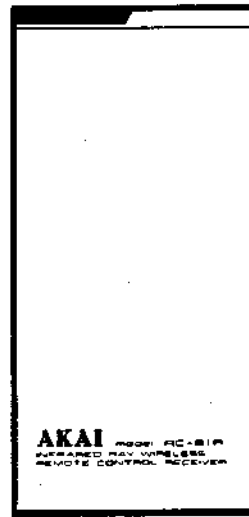
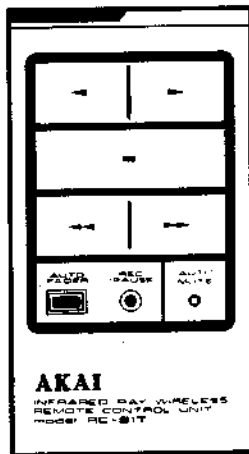
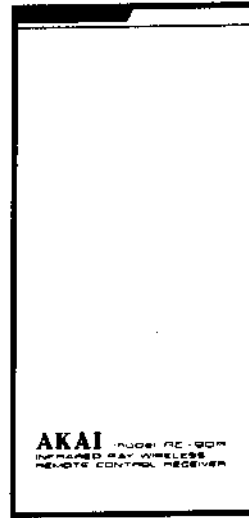
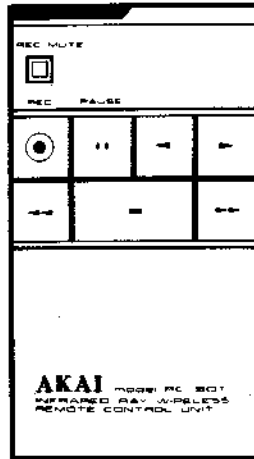

INFRARED RAY WIRELESS REMOTE CONTROL UNIT

RC-90 MODEL RC-91

I. PRECAUTIONS

1. Remote Control Unit RC-90 is for use with:
 - Stereo Tape Deck: GX-747, GX-77
 - Stereo Cassette Deck: CS-F9, CS-F11, CS-F33R, GX-F15, GX-F25, GX-F35, GX-F37, GX-F44R, GX-F47, GX-F66R, GX-F95, UC-F5

* This Unit can also be used with any other equipment marked "RC-21" or RC-90" on the rear panel.
2. Remote Control Unit RC-91 is for use with:
 - Stereo Cassette Deck: GX-F31, GX-F51, GX-F71, GX-F91

* This Unit can also be used with any other equipment marked "RC-31" or RC-91" on the rear panel.

II. SPECIFICATIONS

1. MODEL RC-90

TRANSMITTER RC-90T

SYSTEM	Infrared Ray PCM System
NUMBER OF CHANNELS	14
AREA OF OPERATION	7 m (on axis)
DIRECTIVITY	$\pm 30^\circ$ (at 4m)
OPERATION TIME	5000 times
POWER REQUIREMENT	DC 3V (SUM-3, AA-3 or R6 size battery x 2)
DIMENSIONS	65(W) x 18.5(H) x 120(D) mm
WEIGHT	85 grams (without batteries)

2. MODEL RC-91

TRANSMITTER RC-91T

SYSTEM	Infrared Ray PCM System
NUMBER OF CHANNELS	14
LENGTH OF OPERATION	7 m (on axis)
DIRECTIVITY	$\pm 15^\circ$ (at 4m)
OPERATION TIME	5000 times
POWER REQUIREMENT	DC 3V (SUM-3, AA-3 or R6 size battery x 2)
DIMENSIONS	65(W) x 18.5(H) x 120(D) mm
WEIGHT	85 grams (without batteries)

RECEIVER RC-90R

REMOTE CONTROL PLUG	DIN type (8 pins)
POWER REQUIREMENT	DC 7.5 V (SUM-3, AA-3 or R6 size battery x 5)
POWER CONSUMPTION	4 mA
DIMENSIONS	71(W) x 18.5(H) x 140(D) mm (without remote control cable)
WEIGHT	130 grams (without batteries)

* For improvement purposes, specifications and design are subject to change without notice.

RECEIVER RC-91R

REMOTE CONTROL PLUG	DIN type (8 pins)
POWER REQUIREMENT	DC 7.5 V (SUM-3, AA-3 or R6 size battery x 5)
POWER CONSUMPTION	4 mA
DIMENSIONS	71(W) x 18.5(H) x 140(D) mm (without remote control cable)
WEIGHT	130 grams (without batteries)

* For improvement purposes, specifications and design are subject to change without notice.

III. PARTS LIST

1. MODEL RC-90

1) TRANSMITTER BLOCK RC-90T

REF. NO.	PARTS NO.	DESCRIPTION
1-IC1,2	EI-710031	IC TC40H002
1-IC3,4	EI-710033	IC TC40H008
1-IC5	EI-710034	IC M50110P
1-TR1 to 12	ET-200505	TR 2SC2603 E, F
1-TR13	ET-318603	TR 2SD545NP F
1-D1, 2	ED-562386	D GERMA H 1S188AM
1-D3, 4	ED-705414	D LED SE303A INFRARED
1-SW1	ES-710038	SW SLIDE
1-X1	EZ-710037	OSC CE CSB455E 455KHz
1-1	EA-710030	PC SW RC-90T
1-2	EZ-710026	CONTACT POINT RUBBER
1-3	EZ-710027	TERMINAL BATTERY A
1-4	EZ-710028	TERMINAL BATTERY B
1-5	EZ-710029	TERMINAL BATTERY C
1-6	AX-710025	COVER BATTERY RC-90T

2) RECEIVER BLOCK RC-90R

REF. NO.	PARTS NO.	DESCRIPTION
2-IC1	EI-330226	IC μ PC1373H
2-IC2	EI-710042	IC M50111P
2-IC3	EI-705079	IC TC4028BP
2-TR1	ET-200505	TR 2SC2603 E, F
2-TR2	ET-200558	TR 2SA1115 E, F
2-TR6 to 12	ET-200505	TR 2SC2603 E, F
2-D1	ED-710045	D PHOTO TPS703
2-D2,3	ED-557447	D SILICON H 1S1588
2-SW1	ES-710038	SW SLIDE
2-L1	EO-709902	COIL FS1012-562J
2-X1	EZ-710037	OSC CE CSB455E 455KHz
2-1	EZ-710027	TERMINAL BATTERY A
2-2	EZ-710028	TERMINAL BATTERY B
2-3	EZ-710029	TERMINAL BATTERY C
2-4	EZ-710040	TERMINAL BATTERY D
2-5	AX-710039	COVER BATTERY RC-90R
2-6	EJ-710041	PLUG W/CORD

2. MODEL RC-91

1) TRANSMITTER BLOCK RC-91T

REF. NO.	PARTS NO.	DESCRIPTION
1-IC1	EI-710031	IC TC40H002
1-IC2	EI-710033	IC TC40H008
1-IC3	EI-710034	IC M50110P
1-TR1 to 6	ET-200505	TR 2SC2603 E, F
1-TR7	ET-318603	TR 2SD545NP F
1-D1, 2	ED-705414	D LED SE303A INFRARED
1-SW1	ES-710038	SW SLIDE
1-X1	EZ-710037	OSC CE CSB455E 455KHz
1-1	EZ-710060	CONTACT POINT RUBBER
1-2	EZ-710027	TERMINAL BATTERY A
1-3	EZ-710028	TERMINAL BATTERY B
1-4	EZ-710029	TERMINAL BATTERY C
1-5	EA-710061	PC SW RC-91
1-6	AX-710025	COVER BATTERY RC-90T

2) RECEIVER BLOCK RC-91R

REF. NO.	PARTS NO.	DESCRIPTION
2-IC1	EI-330226	IC μ PC1373H
2-IC2	EI-710042	IC M50111P
2-IC3	EI-705079	IC TC4028BP
2-TR1	ET-200505	TR 2SC2603 E, F
2-TR2	ET-200558	TR 2SA1115 E, F
2-TR6 to 12	ET-200505	TR 2SC2603 E, F
2-D1	ED-710045	D PHOTO TPS703
2-D2,3	ED-557447	D SILICON H 1S1588
2-SW1	ES-710038	SW SLIDE
2-L1	EO-709902	COIL FS1012-562J
2-X1	EZ-710037	OSC CE CSB455E 455KHz
2-1	EZ-710027	TERMINAL BATTERY A
2-2	EZ-710028	TERMINAL BATTERY B
2-3	EZ-710029	TERMINAL BATTERY C
2-4	EZ-710040	TERMINAL BATTERY D
2-5	AX-710039	COVER BATTERY RC-90R
2-6	EJ-710041	PLUG W/CORD

IV. COMPOSITION OF VARIOUS P.C BOARDS

1. RC-90T P.C BOARDS

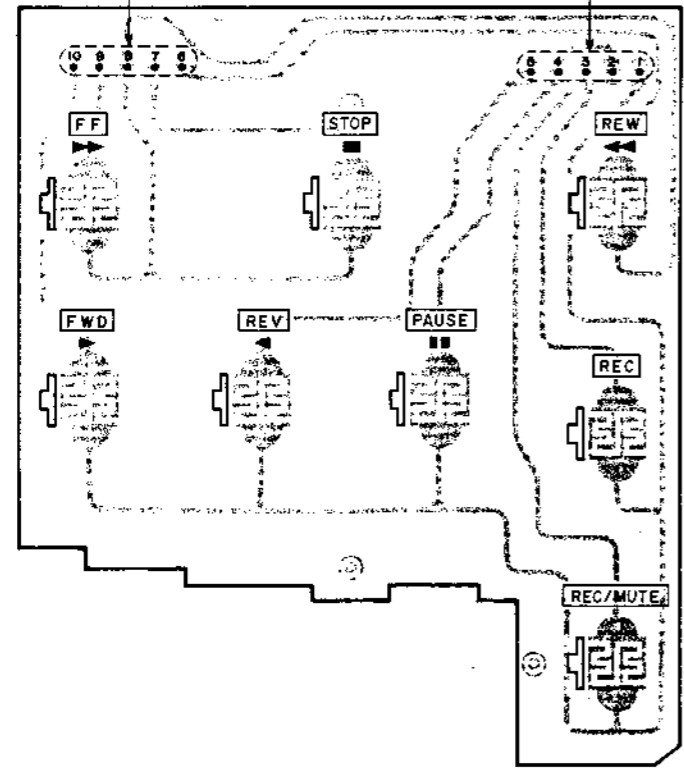
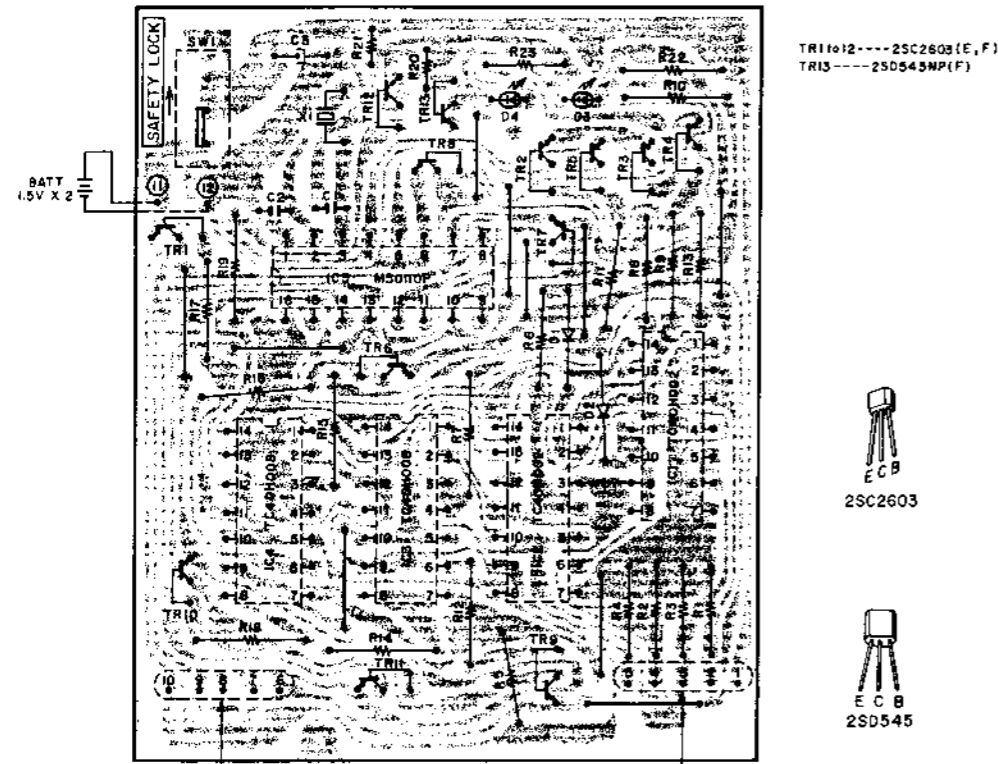

2. RC-90R/91R P.C BOARD

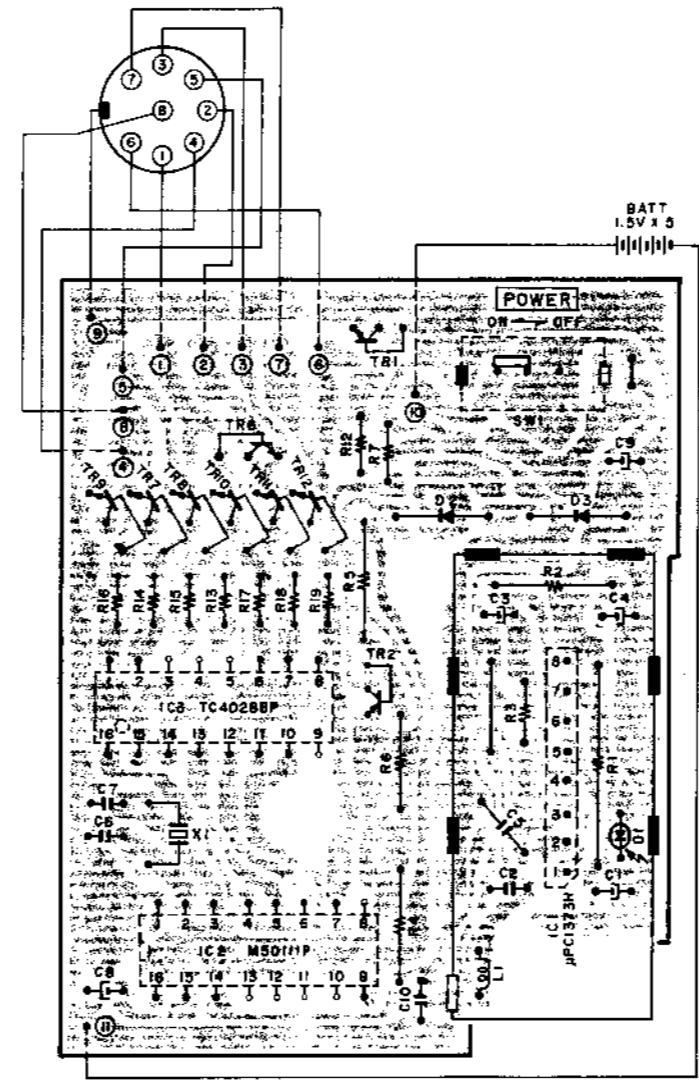

3. RC-91T P.C BOARDS

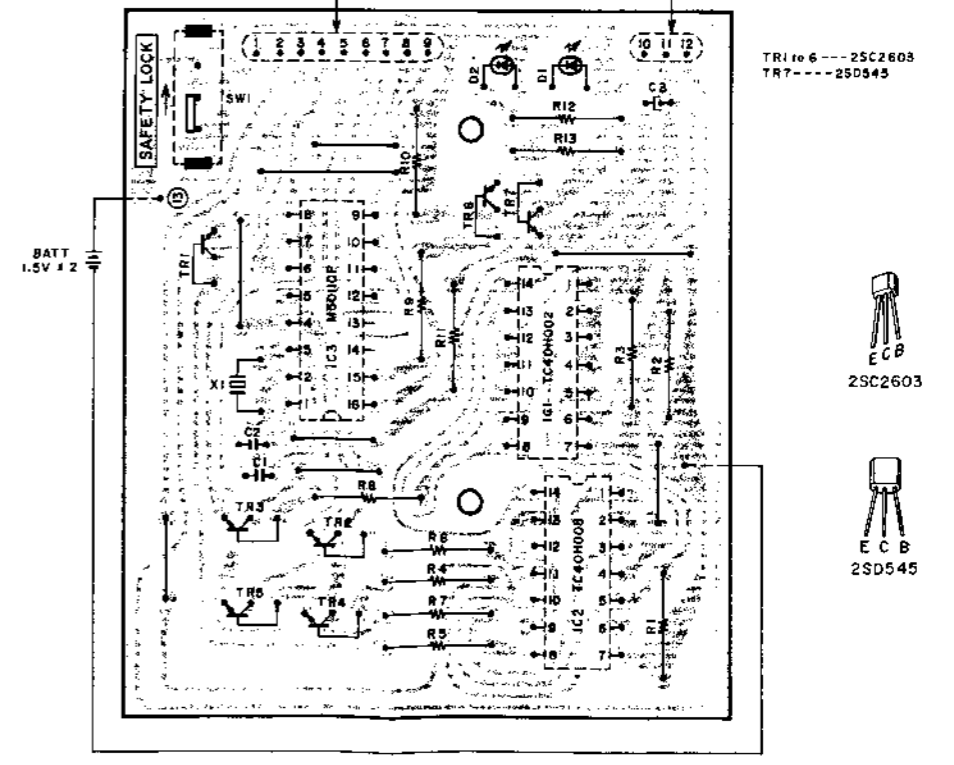
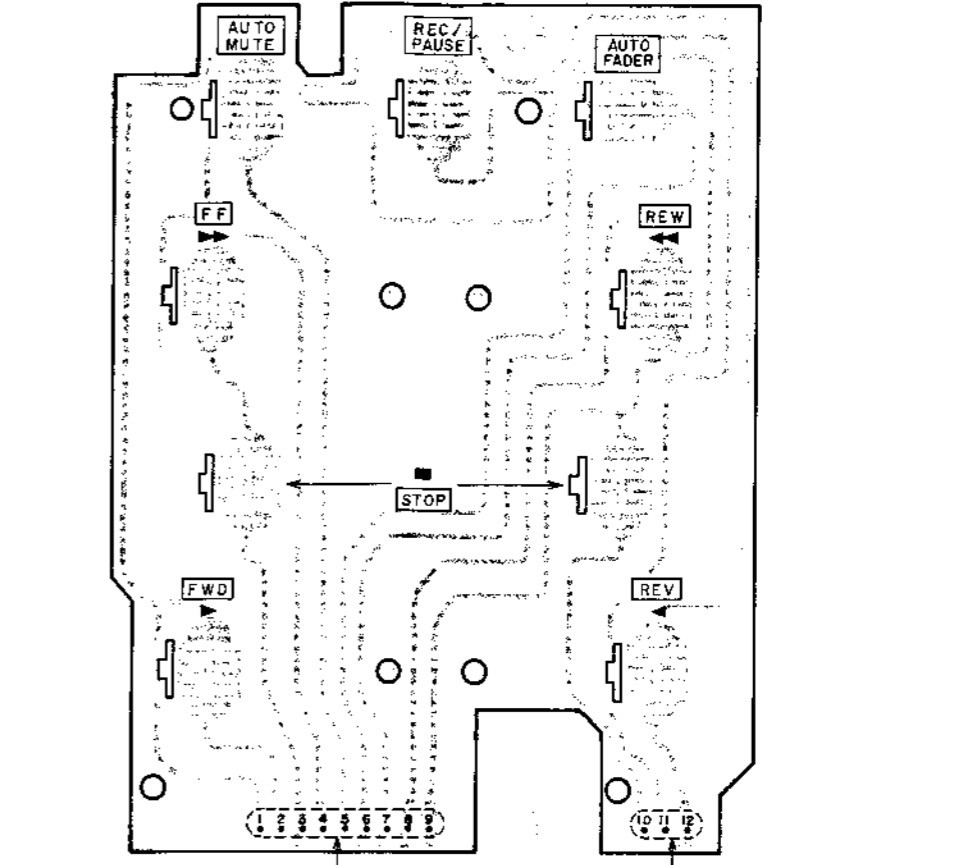

RC-90R/91R

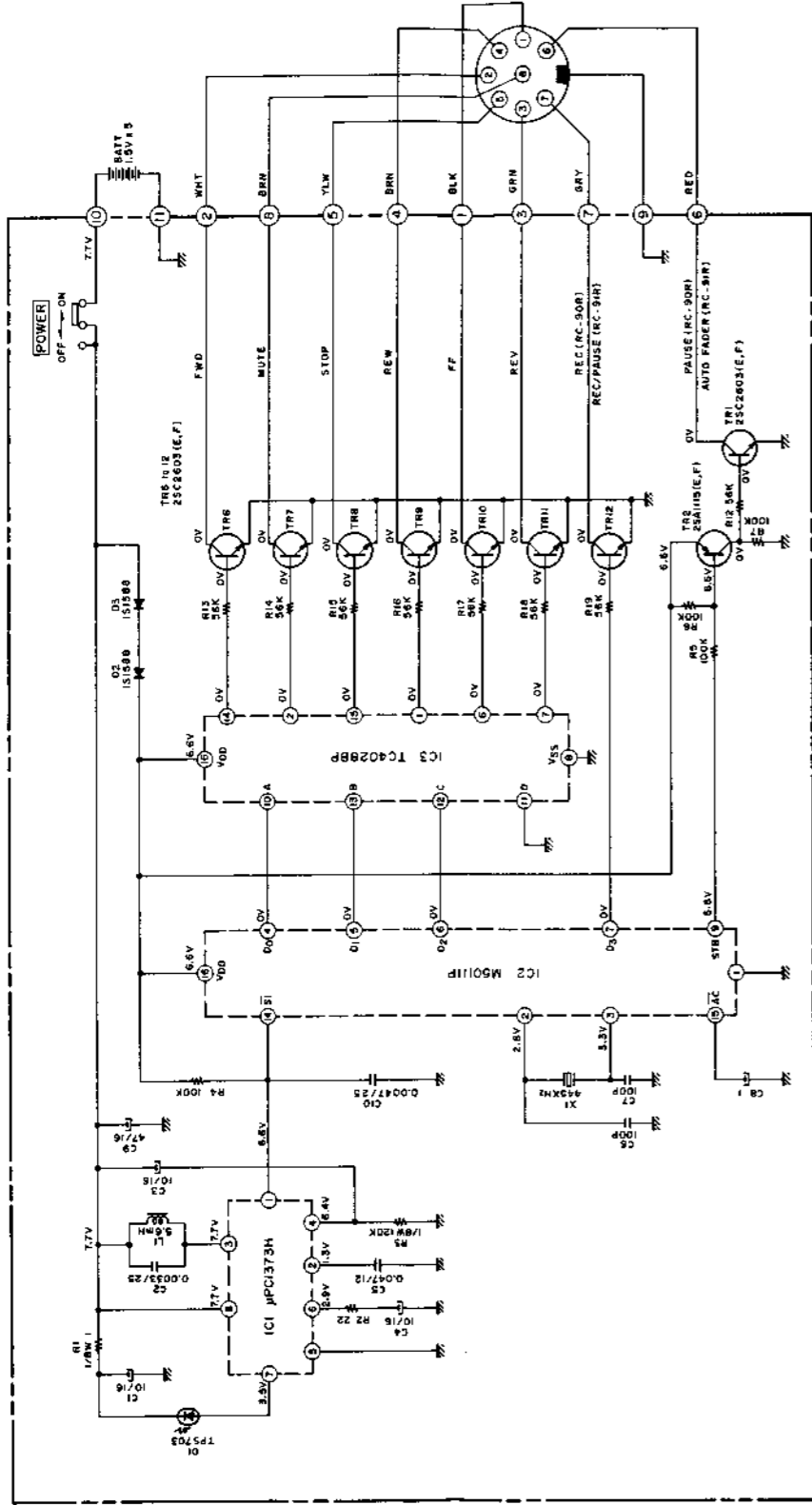

NOTE: UNLESS OTHERWISE SPECIFIED
ALL RESISTORS IN OHMS 1/4W(J)
ALL CAPACITORS IN µF 50 WV(U)

RC-90R/91R
SCHEMATIC DIAGRAM
NO. 1641835A

25A1115
25C2603

RC-91T

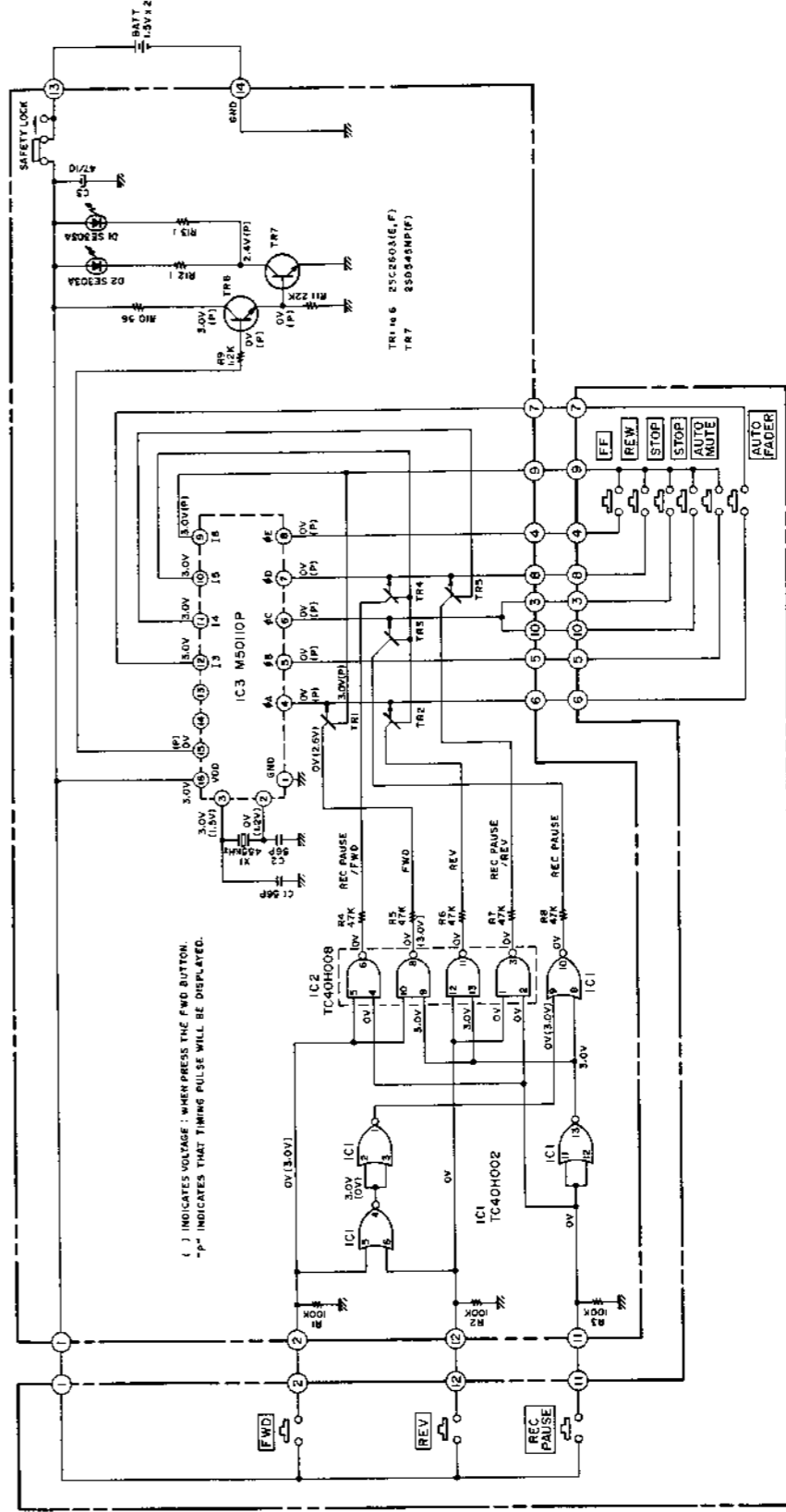

NOTE: UNLESS OTHERWISE SPECIFIED
ALL RESISTORS IN OHMS 1/4W(J)
ALL CAPACITORS IN µF 50WV(U)

RC-91T
SCHEMATIC DIAGRAM
NO. 1641836A

25D545
25C2603

V. SCHEMATIC DIAGRAM OF ICs

M50110P

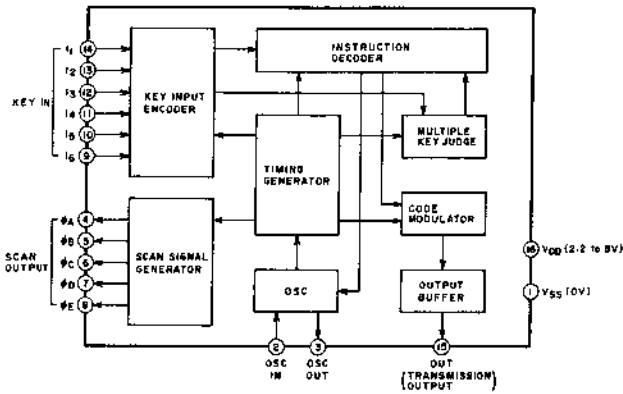

TRANSMISSION CODE (M50110P PIN ⑩)

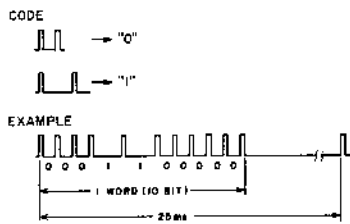

WAVE FORM OF LSI M50110P PIN ⑫ (RC-90T/RC-91T)

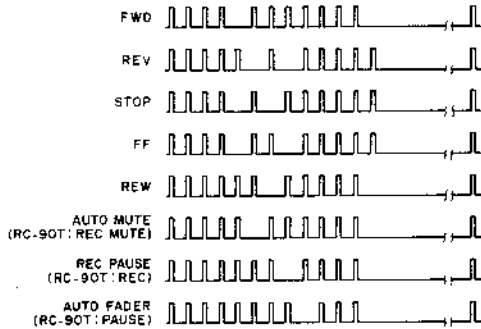

M50111P

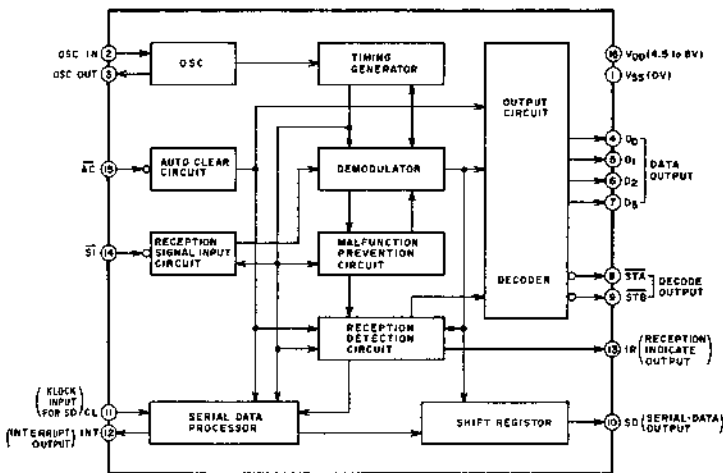

TC40H002P

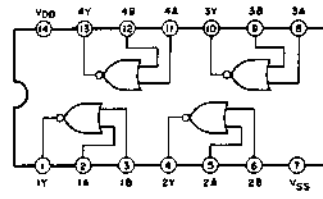

TC40H008P

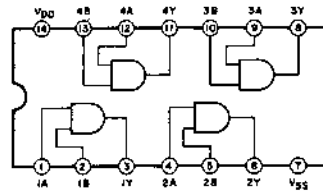

TC4028BP

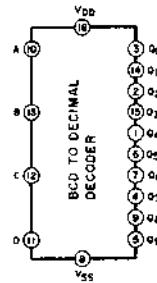

TRUTH TABLE

INPUTS				SELECTED OUTPUT "H"
D	C	B	A	Output
L	L	L	L	Q0
L	L	L	H	Q1
L	L	H	L	Q2
L	L	H	H	Q3
L	H	L	L	Q4
L	H	L	H	Q5
L	H	H	L	Q6
L	H	H	H	Q7
H	L	L	L	Q8
H	L	L	H	Q9

X: DON'T CARE

μPC1373H

