

SERVICE MANUAL

PARTS LIST

PS-200T

MODEL PS-200T

AKAI

ALSO APPLICABLE TO BLACK PANEL MODEL

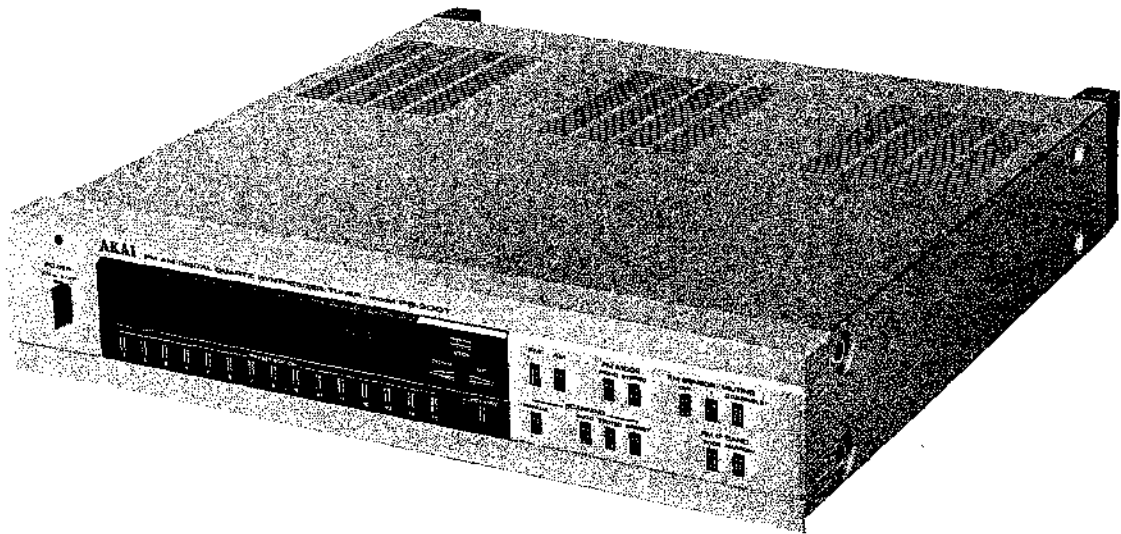

FM AM DIGITAL QUARTZ SYNTHESIZER TUNER

MODEL PS-200T

ALSO APPLICABLE TO BLACK PANEL MODEL

SECTION 1	SERVICE MANUAL	3
SECTION 2	PARTS LIST	29
SECTION 3	SCHEMATIC DIAGRAM	40

SECTION 1

SERVICE MANUAL

TABLE OF CONTENTS

I. TECHNICAL DATA	4
II. DISMANTLING OF UNIT	5
III. CONTROLS	6
IV. PRINCIPAL PARTS LOCATION	7
V. VOLTAGE CONVERSION	8
VI. CIRCUIT OPERATION	9
1. OUTLINE	9
2. BLOCK DIAGRAM	9
3. PLL SYNTHESIZER	10
VII. ADJUSTMENT	12
1. POWER SUPPLY ADJUSTMENT	14
2. AM SECTION ADJUSTMENT	15
3. FM SECTION ADJUSTMENT	16
VIII. CLASSIFICATION OF VARIOUS P.C BOARDS	18
1. P.C BOARD TITLES AND IDENTIFICATION NUMBERS	18
2. COMPOSITION OF VARIOUS P.C BOARDS	19

For basic adjustments, measuring methods, and operating principles, refer to GENERAL TECHNICAL MANUAL.

I. TECHNICAL DATA

FM TUNER SECTION

FREQUENCY RANGE		87.5 MHz to 108 MHz
SENSITIVITY (IHF)		0.8 μ V (75 ohms)
CAPTURE RATIO		1.0 dB
SELECTIVITY (IHF)		More than 100 dB
IMAGE REJECTION		More than 110 dB (98 MHz)
IF REJECTION		More than 110 dB (98 MHz)
SPURIOUS REJECTION		More than 110 dB (98 MHz)
AM SUPPRESSION		60 dB
SIGNAL TO NOISE RATIO		75 dB
HARMONIC DISTORTION	MONO	Less than 0.08% Narrow (100% modulation)
	STEREO	Less than 0.1% wide 0.3% Narrow (100% modulation)
TUNING INDICATOR	SIGNAL	5 point LED
	LOCK	LED
	MULTIPATH	LED
MUTING	LEVEL CONTROL	OFF : 0 dB 1 : 50 μ V 2 : 10 μ V to 100 μ V
STEREO SEPARATION		More than 50 dB (1 kHz)
SUB CARRIER SUPPRESSION		More than 65 dB
OUTPUT VOLTAGE		Variable, Controllable from 0 V to 1.5 V Fixed, 450 mV (100% modulation)
ANTENNA INPUT IMPEDANCE		75 ohms unbalanced

AM TUNER SECTION

FREQUENCY RANGE	513 kHz to 1,647 kHz (520 kHz to 1,610 kHz USA & Canada)
SENSITIVITY (IHF)	6 μ V (external antenna) 50 ohms
SELECTIVITY (IHF)	More than 35 dB
IMAGE REJECTION	More than 70 dB (1,000 kHz)
IF REJECTION	More than 65 dB
SIGNAL TO NOISE RATIO	More than 55 dB
OUTPUT VOLTAGE	Controllable from 0 mV to 500 mV or 150 mV (30% modulation)

MISCELLANEOUS

SEMICONDUCTORS	Transistors: 80, Diodes: 20, FETs: 14, ICS: 36, LED: 23
POWER CONSUMPTION	25W
POWER REQUIREMENTS	120V, 60 Hz for USA & Canada. 220V, 50 Hz for Europe except UK 240V, 50 Hz for UK & Australia 110/220/240V, 50/60 Hz internally switchable for use othe countries
DIMENSIONS	440(W) x 90(H) x 443(D) mm (17.3 x 3.5 x 17.4) inches
WEIGHT	7.8 kg (3.5 lbs)

STANDARD ACCESSORIES

FM di-pole antenna	1
FM external antenna plug	1
AM external antenna plug	1
AM antenna	1
Connection Cords	1 set
Operator's Manual	1

* For improvement purposes, specifications and design are subject to change without notice.

II. DISMANTLING OF UNIT

In case of trouble, etc. necessitating dismantling, please dismantle in the order shown in the photographs. Reassemble in reverse order.

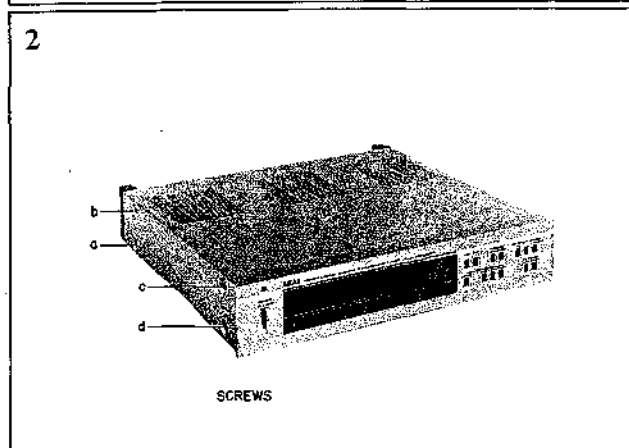
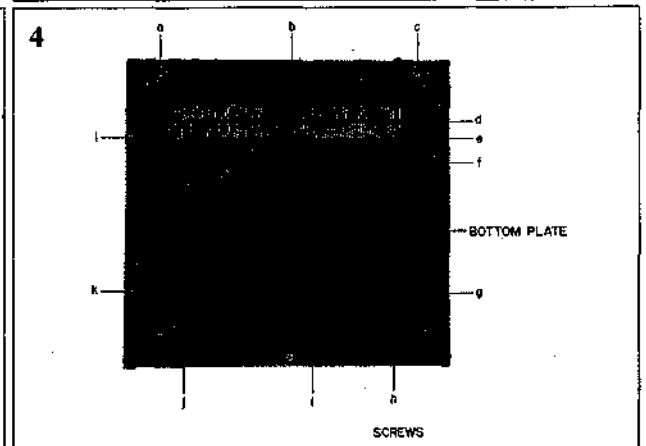
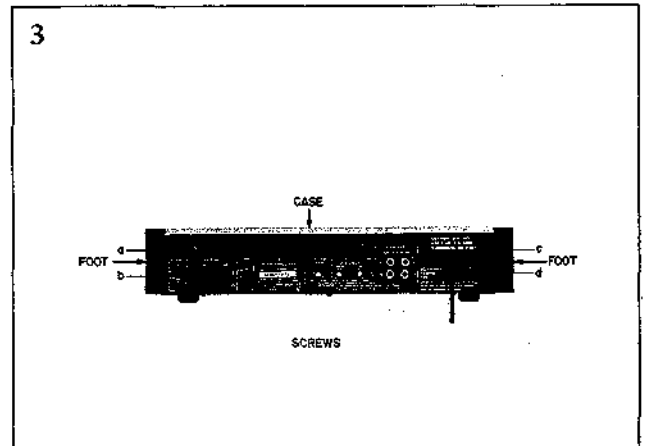
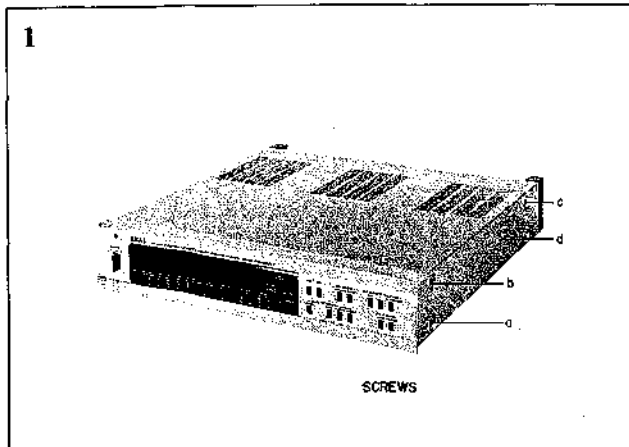

III. CONTROLS

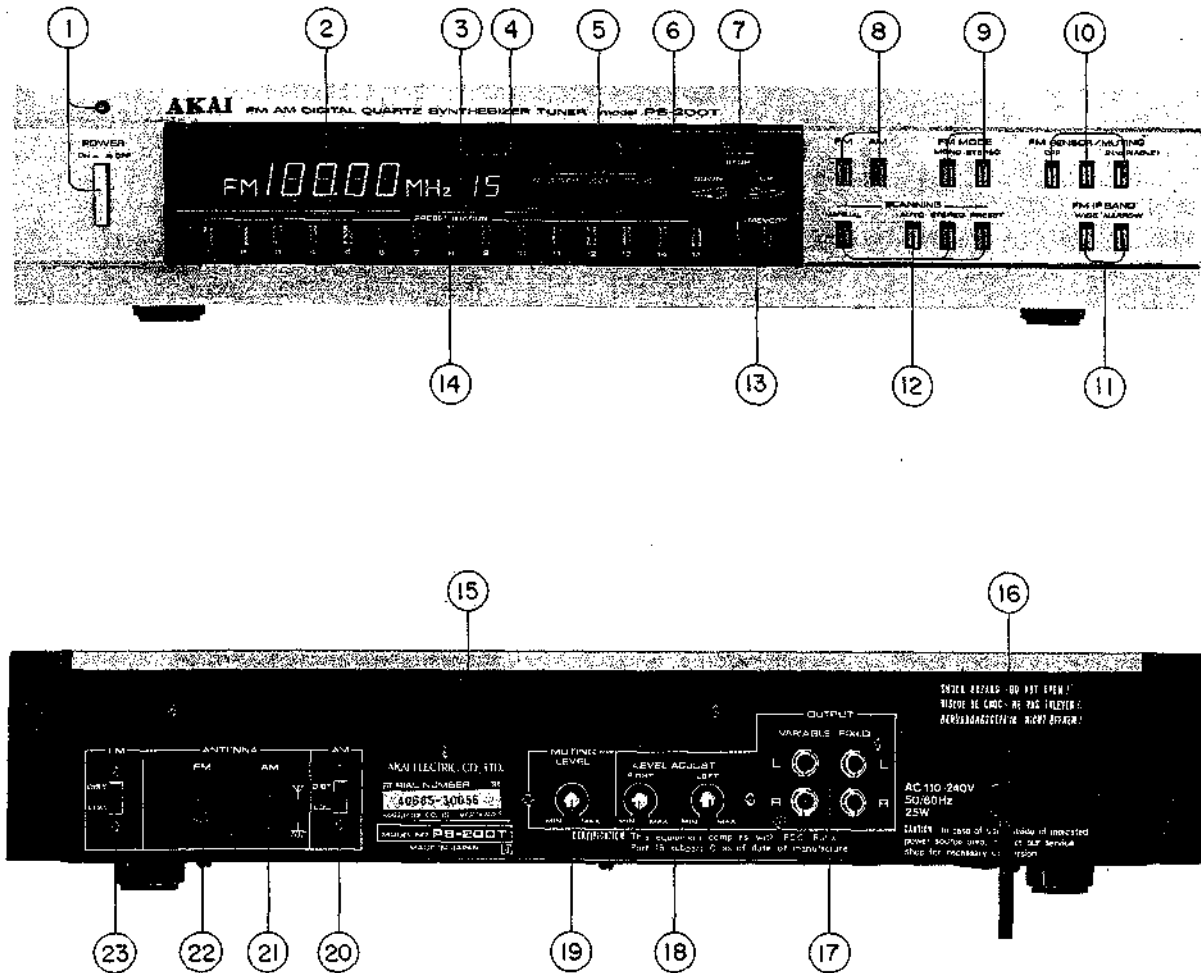

Fig. 3-1

- | | |
|--|---|
| <ol style="list-style-type: none"> 1. POWER SWITCH AND INDICATOR 2. DIGITAL FL DISPLAY 3. FM LOCK INDICATOR 4. MULTIPATH INDICATOR 5. LED SIGNAL STRENGTH METER 6. FM STEREO INDICATOR 7. TUNING SECTION (STOP, UP, DOWN) 8. FM AND AM BAND SELECTORS 9. FM MODE SELECTOR (MONO, STEREO) 10. FM SENSOR/MUTING SWITCHES 11. FM IF BAND SELECTOR BUTTONS 12. SCANNING (MANUAL, AUTO, STEREO, PRESET) | <ol style="list-style-type: none"> 13. MEMORY BUTTON AND MEMORY INDICATOR 14. PRESET STATIONS 15. MEMORY BATTERY BOX 16. AC POWER CORD (AC INLET FOR SOME COUNTRIES) 17. OUTPUT (VARIABLE, FIXED) 18. OUTPUT LEVEL ADJUSTMENT CONTROL 19. AUDIO MUTE LEVEL 20. AM ANTENNA SWITCH 21. AM EXTERNAL ANTENNA JACKS 22. FM EXTERNAL ANTENNA JACKS 23. FM ANTENNA SWITCH (LOCAL, DIST) |
|--|---|

IV. PRINCIPAL PARTS LOCATION

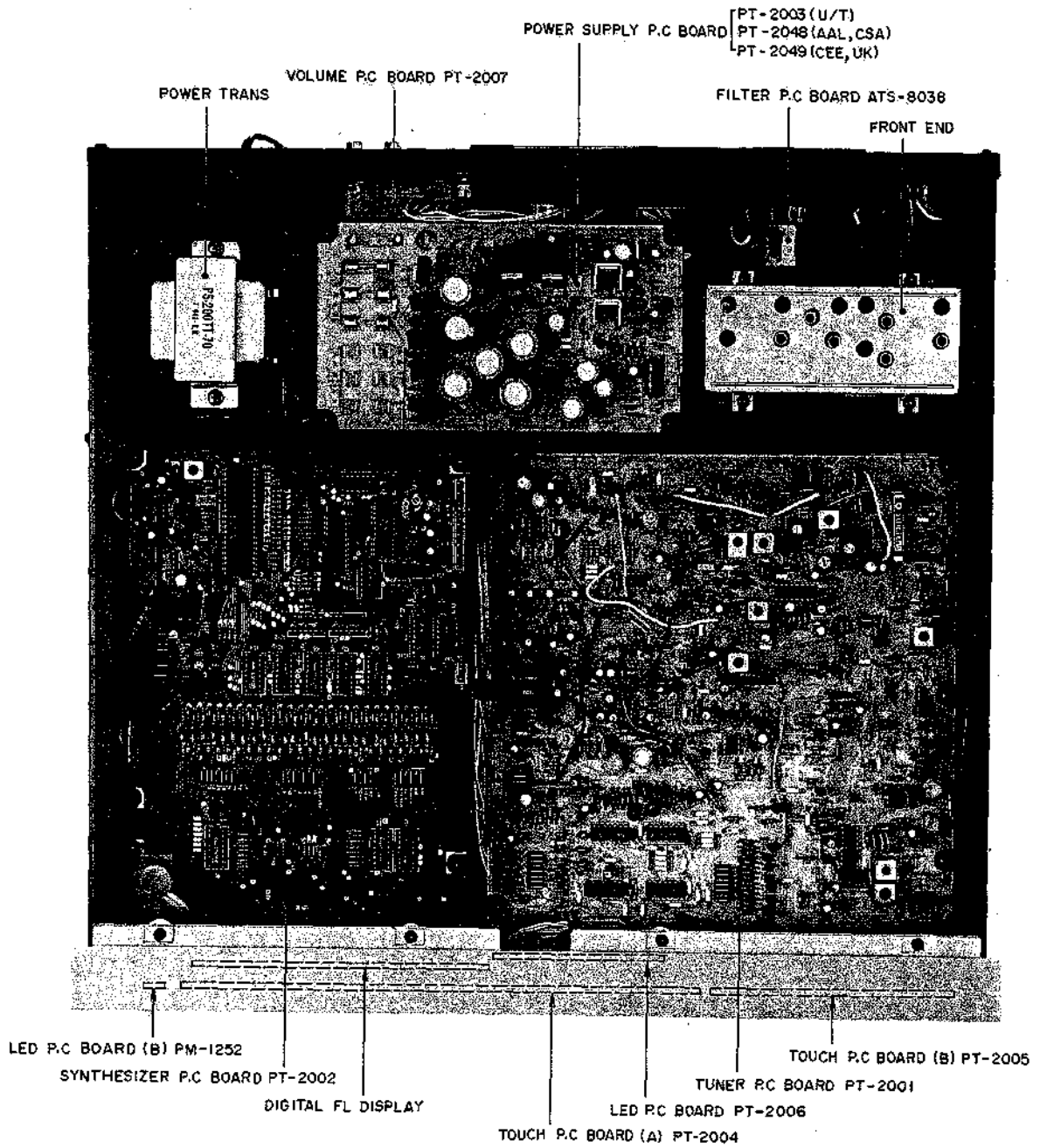

Fig. 4-1 Top View (U/T Model)

V. VOLTAGE CONVERSION

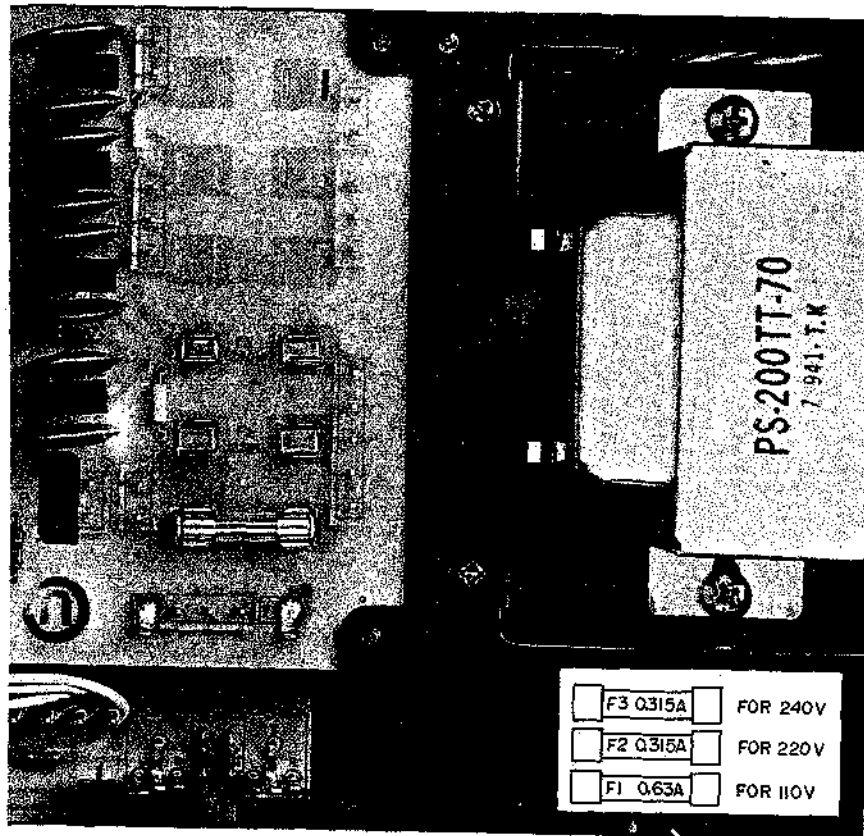

Fig. 5-1

(Models for Canada, USA, Europe, UK and Australia are not equipped with this facility.)

Each machine is preset at the factory according to destination but some machines can be set to 110V, 220V or 240V as required.

If voltage change is necessary, this can be accomplished as follows.

- 1) Disconnect AC Power Cord.
- 2) Loosen holding screws and remove upper case.
(Refer to Section 2.)
- 3) Remove existing line voltage fuse and insert required line voltage fuse in proper fuse holder, explicitly following instructions printed inside the tuner near the line voltage fuses.

VI. CIRCUIT OPERATION

1. OUTLINE

The PS-200T is a synthesizer AM/FM tuner with a micro-processor and with the power switch out, uses the touch switch for all front panel operation. Different from existing tuners in that there is no mechanical varicon, there is no longer the cumbersome turning of the tuning dial by hand. Furthermore, by pressing in the batteries (1.5 x 3) in the Rear Panel, it can back up the memory of each mode

and when the power source is cut off and switched on again each mode will have retained the memory that was there before the power source was cut off. Even without the batteries several hours of back up memory are possible due to the Electric Condenser's power supply circuit.

There are various PS-200T models for USA, Canada, European countries etc. so the important differences are outlined below.

	USA, Canada	Europe
AM Frequency Range	520 kHz ~ 1,610 kHz	513 kHz ~ 1,647 kHz
AM Step Frequency	10 kHz	9 kHz
AM IF Frequency	460 kHz	459 kHz
FM Frequency Range	87.5 MHz ~ 108 MHz	87.5 MHz ~ 108 MHz
FM Step Frequency	100 kHz	50 kHz
De-emphasis	75 μ sec	50 μ sec

2. BLOCK DIAGRAM

1) FM Block Diagram

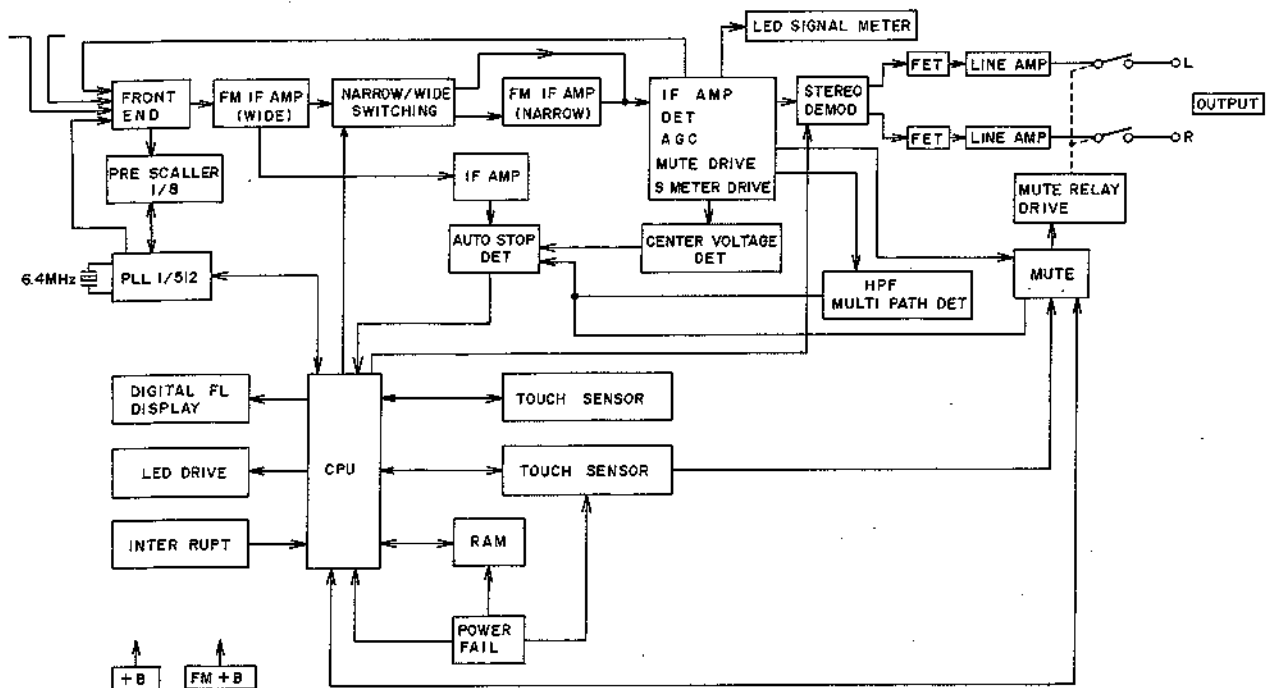

Fig. 6-1

2) AM Block Diagram

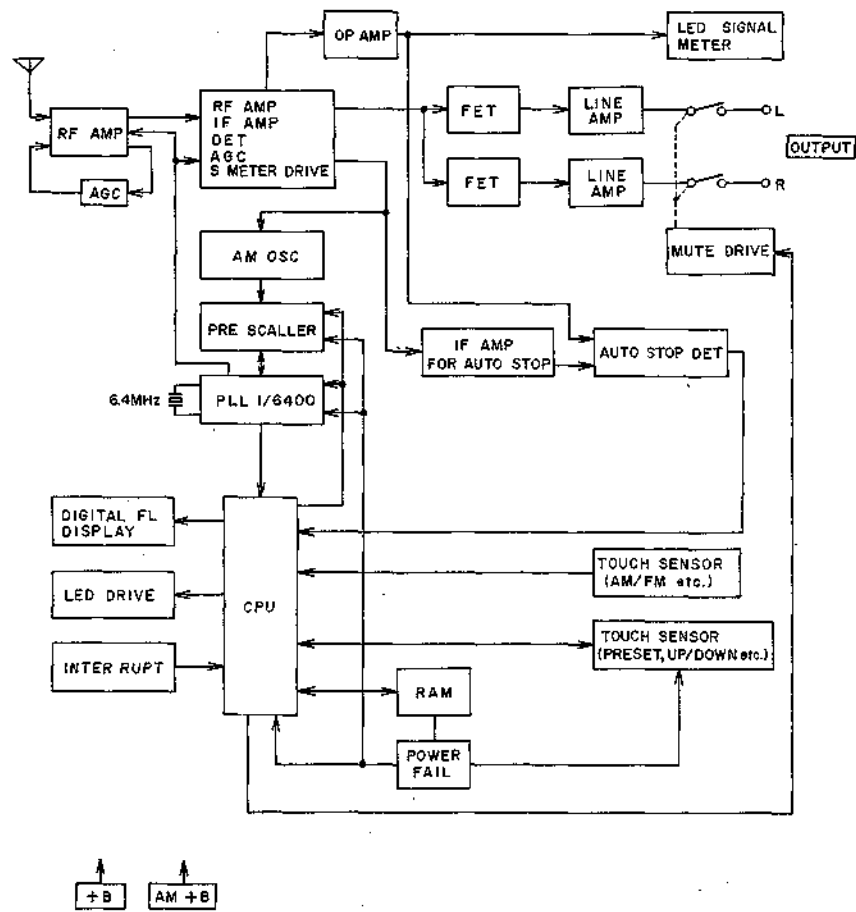

Fig. 6-2

3. PLL SYNTHESIZER

1) FM

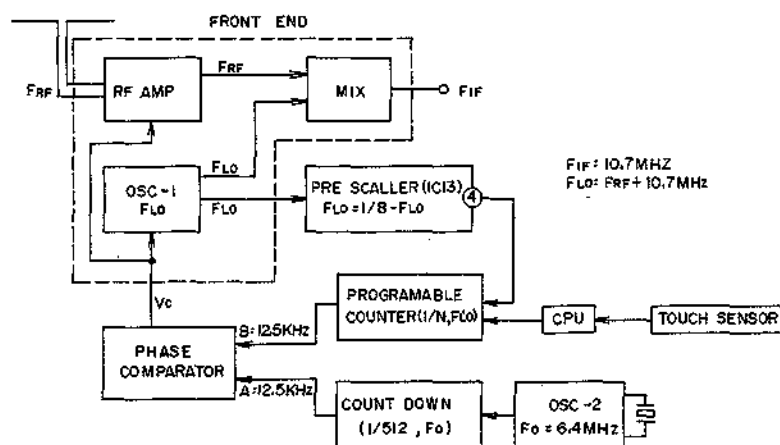

Fig. 6-3 PLL Synthesizer Block Diagram (FM)

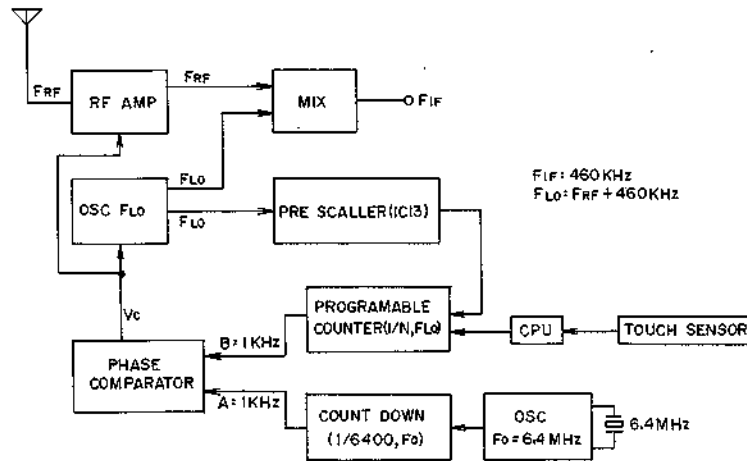

Fig. 6-4 PLL Synthesizer Block Diagram (AM)

Now in Fig. 6-3 is an explanation of when FM 98 MHz broadcast is received. First, when the desired broadcast station (98 MHz in this case) is designated by the Touch Sensor, the countdown ratio N of the Programmable Counter is established at 1084 (at 98 MHz). In the input A of the phase comparator a standard signal 12.5 kHz made by OSC-2 is added.

Up to the phase comparator's input comparison signal B reaching 12.5 kHz against this standard signal A the phase comparator's output voltage VC changes and it also changes until the frequency has the oscillation frequency FLo of OSC-1 (in this case 108.7 MHz).

In other words, if the countdown ratio N of the Programmable Counter is 1084, at the point when comparison signal of the phase comparator becomes 12.5 kHz, the frequency FLo of the OSC-1 is 108.7 MHz.

Therefore the FM IF frequency is $10.7 \text{ MHz} = 108.7 \text{ MHz} - 98 \text{ MHz}$.

Always at the point where the IF frequency becomes 10.7 MHz, the OSC-1 frequency changes by establishing the countdown ratio N of the Programmable Counter and is locked on.

2) AM

The operation of the AM's PLL synthesizer's operation is practically the same as for FM. The difference is that because AM has a low frequency compared with FM, the pre-scaler's countdown ratio is 1/1 and the countdown is 1/6450 and the standard frequency is 1 kHz.

For example, when receiving an AM broadcast of 900 kHz,

$$F_{IF} = 950 \text{ kHz} + 460 \text{ kHz} = 1360 \text{ kHz}$$

Therefore the countdown ratio N of the Programmable Counter should be 1360. In other words, when selecting a 950 kHz broadcast with the Touch Sensor by CPU the countdown ratio of the Programmable Counter become 1/1360 and the phase comparator's output VC changes and when the local oscillator frequency FLo becomes 1360 kHz it locks on.

VII. ADJUSTMENT

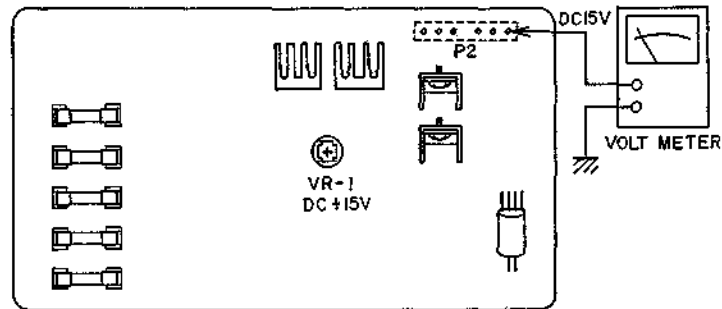
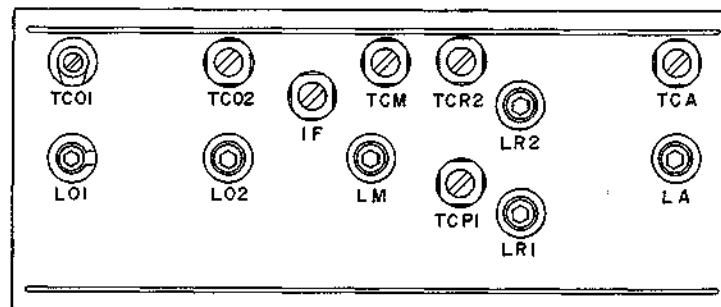

Fig. 7-1 Power Supply P.C Board



IF : DISTORTION
 LA, LRI, LR2, LM, LO2 : LOW FREQUENCY SENSITIVITY
 TCA, TCR1, TCR2, TCM, TC02 : HIGH FREQUENCY SENSITIVITY
 TCO1, LO1 : DO NOT TOUCH (ADJUSTED BY FACTORY)

Fig. 7-2 Front End

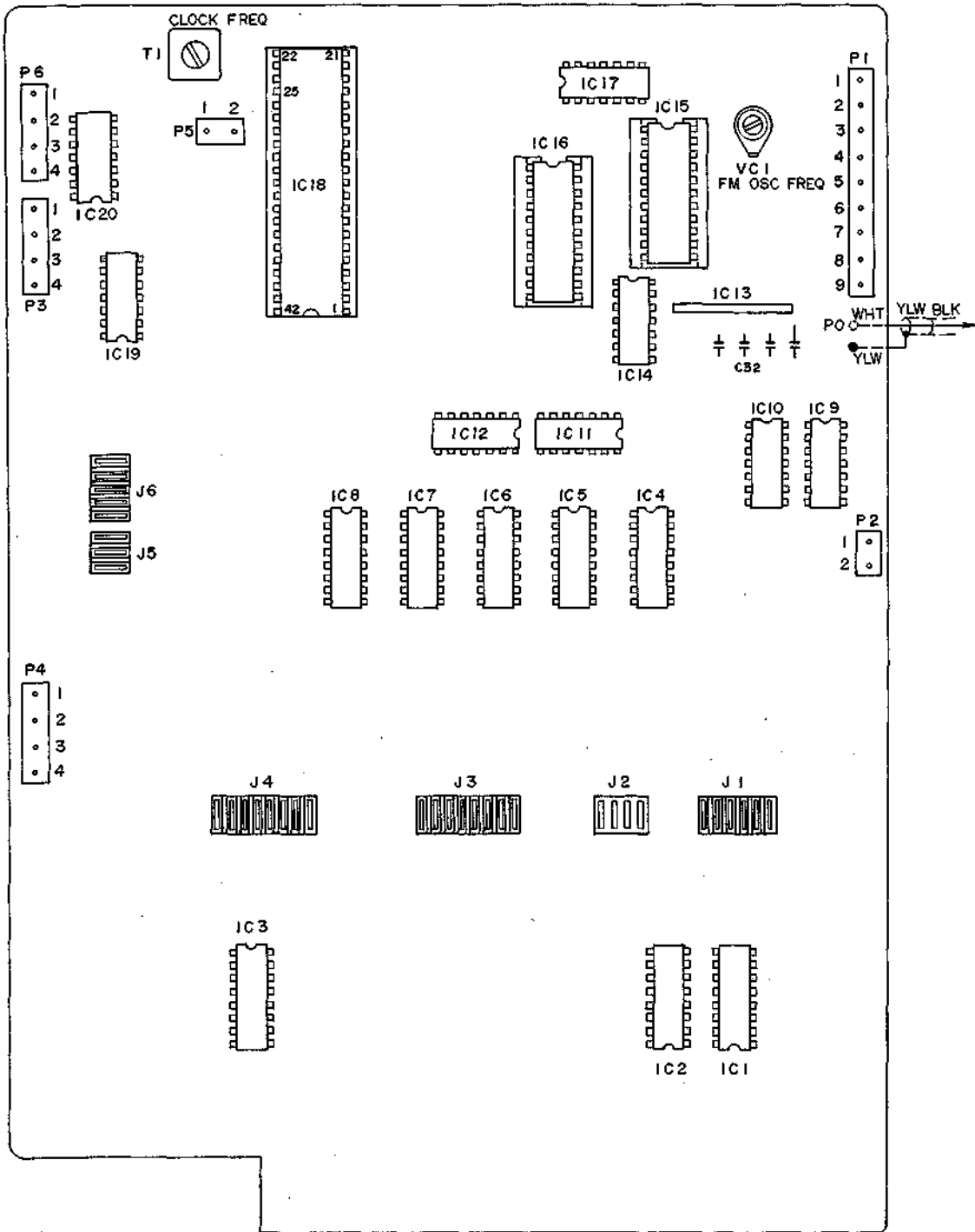

Fig. 7-3 Synthesizer P.C Board

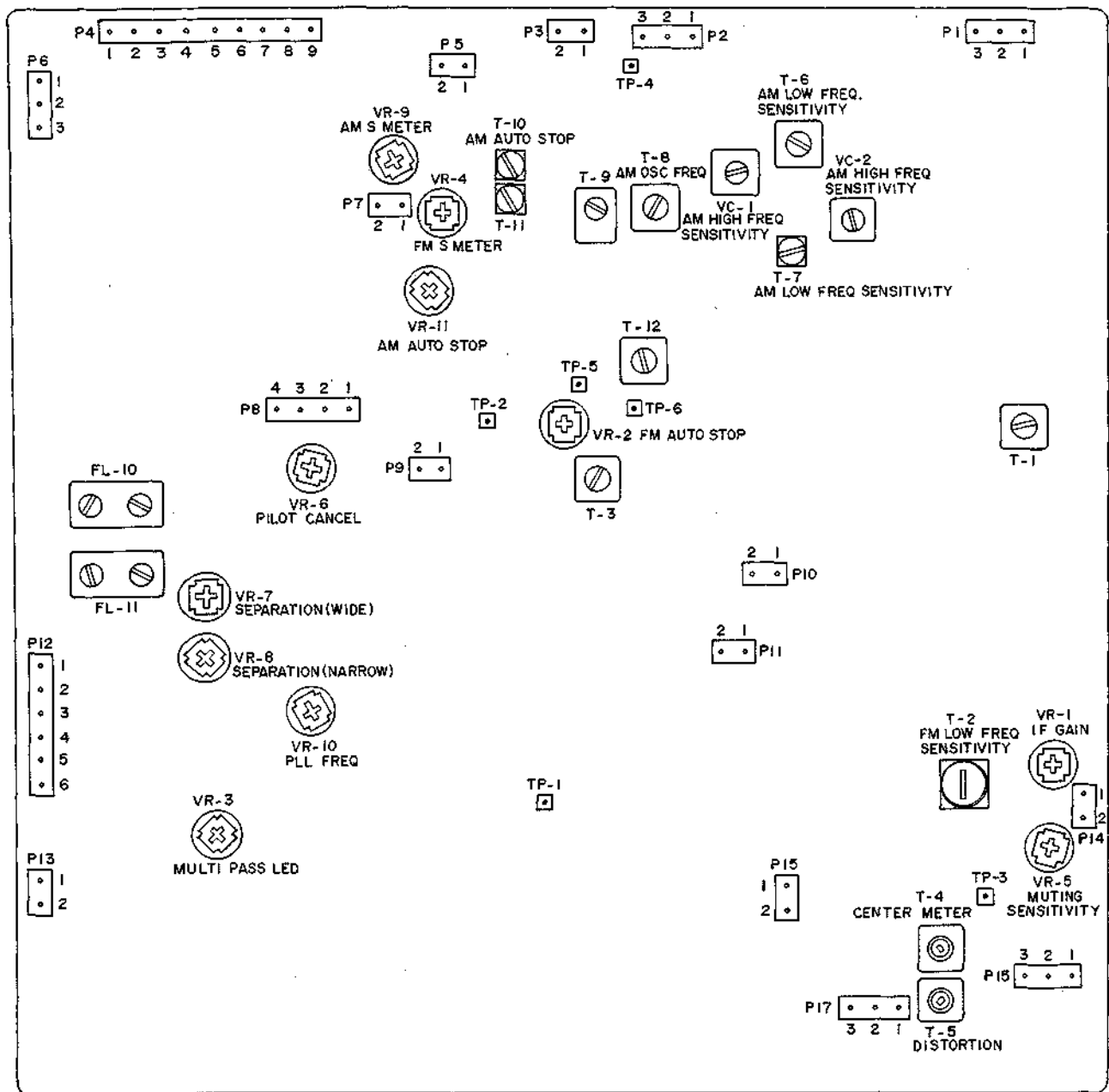

Fig. 7-4 Tuner P.C Board (PT-2001)

1. POWER SUPPLY ADJUSTMENT (Refer to Fig. 7-1)

STEP	ADJUSTMENT ITEMS	TEST POINTS	ADJUSTMENT PARTS	RESULT & REMARKS
1	DC + 15 V	P2-1	VR-1	DC + 15 V (Volt Meter)

2. AM SECTION ADJUSTMENT (Refer to Fig. 7-3, 7-4)

STEP	ADJUSTMENT ITEMS	TEST POINTS	ADJUSTMENT PARTS	RESULT & REMARKS
1	Clock Freq.	IC 18 (Pin 25) (PT-2002)	T-1 (PT-2002)	470 kHz \pm 1 kHz (Frequency Counter)
2	AM OSC Freq.	P3-2 PT-4	T-8	710 kHz \pm 1 kHz (Frequency Counter), TP-4 should be grounded at the shortest possible distance.
3	Low Freq. Sensitivity (600 kHz or 603 kHz)	Output	T-6 T-7	1) Set Digital FL Display to 100 kHz (603 kHz). 2) Feed a signal of 600 kHz (603 kHz), 30% modulation, 20 dB from SSG to Ant Input. 3) Adjust so that the SSG output is approximately less than 16 dB when the distortion factor is 10%. (Distortion Meter and SSG) NOTE 1, 2
4	High Freq. Sensitivity (1,400 kHz or 1,404 kHz)	Output	TC 1 TC 2	Adjust the sensitivity at 1,400 kHz (1,404 kHz) by the same as step 3.
5	Mid. Freq. (1,000 kHz or 999 kHz)	Output	Confirm	Check the sensitivity and distortion at 1,000 kHz (999 kHz) by the same as step 3.
6				Readjust in step 3 to 5.
7	Auto Stop	TP-5	T-10 T-11	The output of TP-5 to the maximum by feeding 1,000 kHz (999 kHz), 30 dB from SSG to Ant Input.
		P8-4	VR-11	Feed 1,000 kHz (999 kHz), 20 \pm 6 dB from SSG to Ant Input and make adjustment until P8-4 becomes "H" level. (Oscilloscope) (NOTE 3)
8	S Meter Sensitivity	S Meter (LED)	VR-9	1) Feed 1,000 kHz (999 kHz), 30% modulation, 50 dB \pm 6 dB from SSG to Ant Input. 2) Adjust VR-9 until the fifth lamp of S meter LED is lighted.

- NOTES:**
- AM Step Frequency of Digital FL Display is stepped up or down by the unit of 10 kHz in the USA, Canada, etc. and 9 kHz in European countries, etc.
 - With Model PS-200T, the frequency of Digital FL Display is locked by a digital circuit at intervals of 10 kHz (or 9 kHz).
Therefore, adjust the output frequency of SSG by checking the frequency counter.
 - When turning VR-11 "L" level (0 V) changes instantaneously to "H" level (approx. DC 5 V) at a certain point and this point means the point to obtain "H" level. This function is normal when "H" level changes to "L" level when ATT of SSG is lowered by 1 dB.
 - For the adjustment, set AM Ant Switch to "DIST" side.
 - IF any test point or adjustment parts are not specified, refer to Tuner P.C Board (Fig. 7-4).
 - It may be convenient to Pre-set the display frequency of Digital FL Display to the frequency to be used before performing the adjustment, but in such a case, be sure to return the frequency to the frequency pre-set by the customer when the adjustment is made.

3. FM SECTION ADJUSTMENT (Refer to Fig. 7-2 ~ Fig. 7-4)

STEP	ADJUSTMENT ITEMS	TEST POINTS	ADJUSTMENT PARTS	RESULT & REMARKS
1	Clock Freq.	IC 18 (Pin 25) (PT-2002)	T-1 (PT-2002)	470 kHz \pm 1 kHz (Frequency Counter)
2	FM OSC Freq.	P0 (PT-2002)	VC-1 (PT-2002)	(Digital FL Display Freq. + 10.7 MHz) \pm 1 kHz (Frequency Counter) (NOTE 1)
3	PLL Freq.	P12-2	VR-10	76 kHz \pm 76 Hz (Frequency Counter)
4	Center Meter	P17-1 P17-3	T-4	1) Connect the center meter between P17-1 and P17-3. (NOTE 2) 2) Feed 90 MHz, 54 dB from SSG to Ant Input. 3) Set IF Band SW. to "Wide" and adjust T-4 until the needle of center meter indicates the center of scale. (Center meter should be connected until the adjust- ment is completed)
5	Distortion	Output	T-5 IF (Front End)	Minimize the distortion under the condition described in step 4. (Distortion Meter)
6				Readjust in steps 4 and 5.
7	Low Freq. Sensitivity (90 MHz)	Output	VR 1 T-2	1) Feed 90 MHz, 5 dB from SSG to Input. 2) Set VR-1 to the center. 3) Obtain a maximum output by adjusting T-2. (VTVM)
		Output	LA, LR1, LR2 LM, L02 (Front End)	Input the 90 kHz signal from SSG, into Ant. Input and at the point where distortion is 3% adjust so that the SSG's ATT is less than 5 dB. (Distortion Meter)
8	High Freq. Sensitivity (106 MHz)	Output	TCA, TCR1 TCR2, TCM TC02 (Front End)	Input the 106 kHz signal from the SSG into Ant. Input and at the point where distortion is 3% adjust so that the SSG's ATT is less than 5 dB.
9				Readjust in steps 7 and 8.
10	IF Gain	TP-3	VR-1	1) Feed 98 MHz, 30 dB from SSG to Ant Input. 2) Adjust VR-1 so that the electric potential is kept same when IF Band Switch is set to "Wide" and "Narrow" (VTVM) (NOTE 3).
11	Muting Sensitivity	Output	VR-5	1) Set FM IF Band switch to "Wide". 2) Set FM Sensor/Muting switch to "1". 3) Feed 98 MHz, 30 dB from SSG to Ant Input. 4) Set VR-5 to the point where the output is produced at SSG ATT. 30 dB and disappears at 29 dB. 5) Set FM IF Band switch to "Narrow" and make adjustment as described in the above 2) to 4). If the sensitivity can not be adjusted to the required range, repeat step 10.
12	S Meter Sensitivity	S Meter LED	VR-4	Feed 98 MHz, 54 dB \pm 6 dB from SSG to Ant. Input and adjust VR-4 until the fifth lamp of S Meter LED is lighted. (NOTE 4)

STEP	ADJUSTMENT ITEMS	TEST POINTS	ADJUSTMENT PARTS	RESULT & REMARKS
13	Auto Stop Level	TP-2	VR-2	1) Feed 98 MHz, 20 dB \pm 6 dB from SSG to Ant. Input. 2) Set FM Sensor/Muting switch to the "Off" position. 3) Adjust VR-2 to such a point where the voltage of TP-2 change from "H" level to "L" level. (Oscilloscope) (NOTE 5)
14	Separation (Wide)	Output	VR-7	1) Set FM IF Band Switch to the "Wide" side. 2) Feed the signal of 98 MHz, 60 dB, stereo L-CH from SSG to Ant Input. 3) Adjust VR-7 until L-CH Output becomes maximum and R-CH output becomes minimum. 4) Equally adjust L-CH in connection with R-CH by means of VR-7. (VTVM)
15	Separation (Narrow)	Output	VR-8	Set IF Band Switch to "Narrow" and adjust VR-8 in the same manner as Step 14 (VTVM).
16	Pilot Cancel	Output	VR-6	Minimize the distortion and adjust the separation to the optimum point (Distortion meter, VTVM).
17	Multi Pass LED	Multi Pass LED	VR-3	This is the point where Mute is "OFF" and LED is not lighted when there is no input.

- NOTES:**
- (Digital FL Display Frequency + 10.7 MHz) \pm 1 kHz means that when the display frequency of Digital FL Display is 100 MHz, it should be adjusted to 110.7 MHz \pm 1 kHz.
 - For the center meter, use a tuning meter supplied as a part of other models. Before adjustment, disconnect the shorting wire between P17-1 and P17-3. Do not forget to reconnect after the repairs have been completed.
 - Measure the voltage on the "Wide" side and adjust VR-1 until the electric potential on the "Narrow" side becomes equal to the potential on the "Wide" side.
 - The point where the fifth lamp of LED is lighted is the point where the fifth lamp of LED is turned off when ATT is reduced by 1 dB.
 - The point where "H" level changes to "L" level means the point where the level changes to "H" level when ATT is increased by 1 dB.
 - Unless otherwise specified adjustment should be made on IF Band "Narrow" side and Ant Switch "Dist" side.
 - The test points and adjustment parts are provided on Tuner P.C Board (Fig. 7-4, if not specified particularly).
 - It may be convenient to pre-set the display frequency of Digital FL Display to the frequency to be used before performing the adjustment, but in such a case, be sure to return the frequency to the frequency pre-set by the customer when the adjustment is completed.

VIII. CLASSIFICATION OF VARIOUS P.C BOARDS

1. P.C BOARD TITLES AND IDENTIFICATION NUMBERS

P.C Board Titles	Number of P.C Boards
Tuner P.C Board	PT-2001
Synthesizer P.C Board	PT-2002
Power Supply P.C Board (U/T)	PT-2003
Power Supply P.C Board (AAL, CSA)	PT-2048
Power Supply P.C Board (CEE, UK)	PT-2049
Touch P.C Board (A)	PT-2004
Touch P.C Board (B)	PT-2005
LED P.C Board	PT-2006
Volume P.C Board	PT-2007
Fuse P.C Board (CSA, AAL)	PT-2045
Fuse P.C Board (CEE, UK)	PT-2050
Filter P.C Board	ATS-8038
Battery P.C Board	ATS-8039
LED P.C Board (B)	PM-1232

2. COMPOSITION OF VARIOUS P.C BOARDS

1) TUNER P.C BOARD (2ED) PT-2001

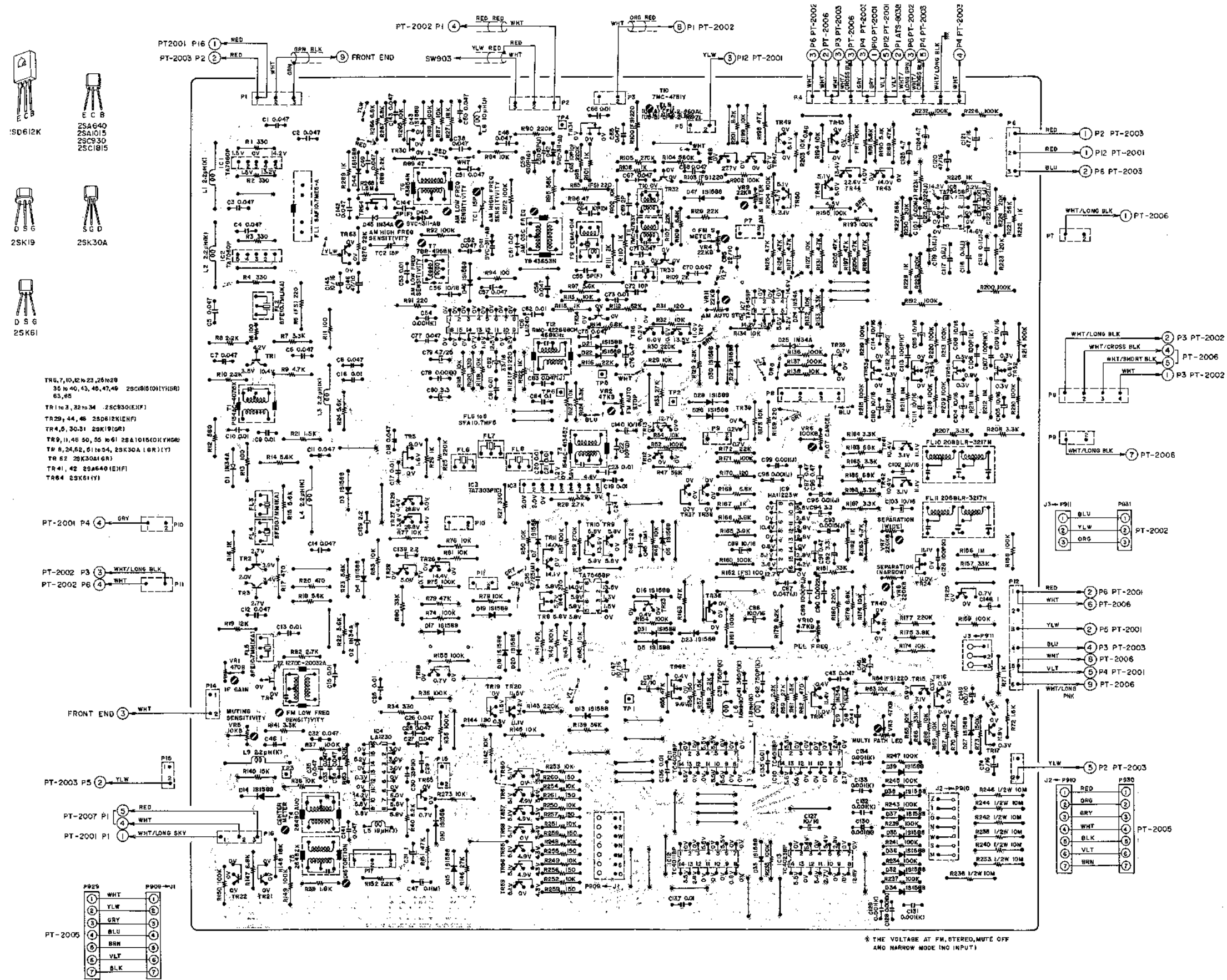

2) SYNTHESIZER P.C BOARD (2ED) PT-2002

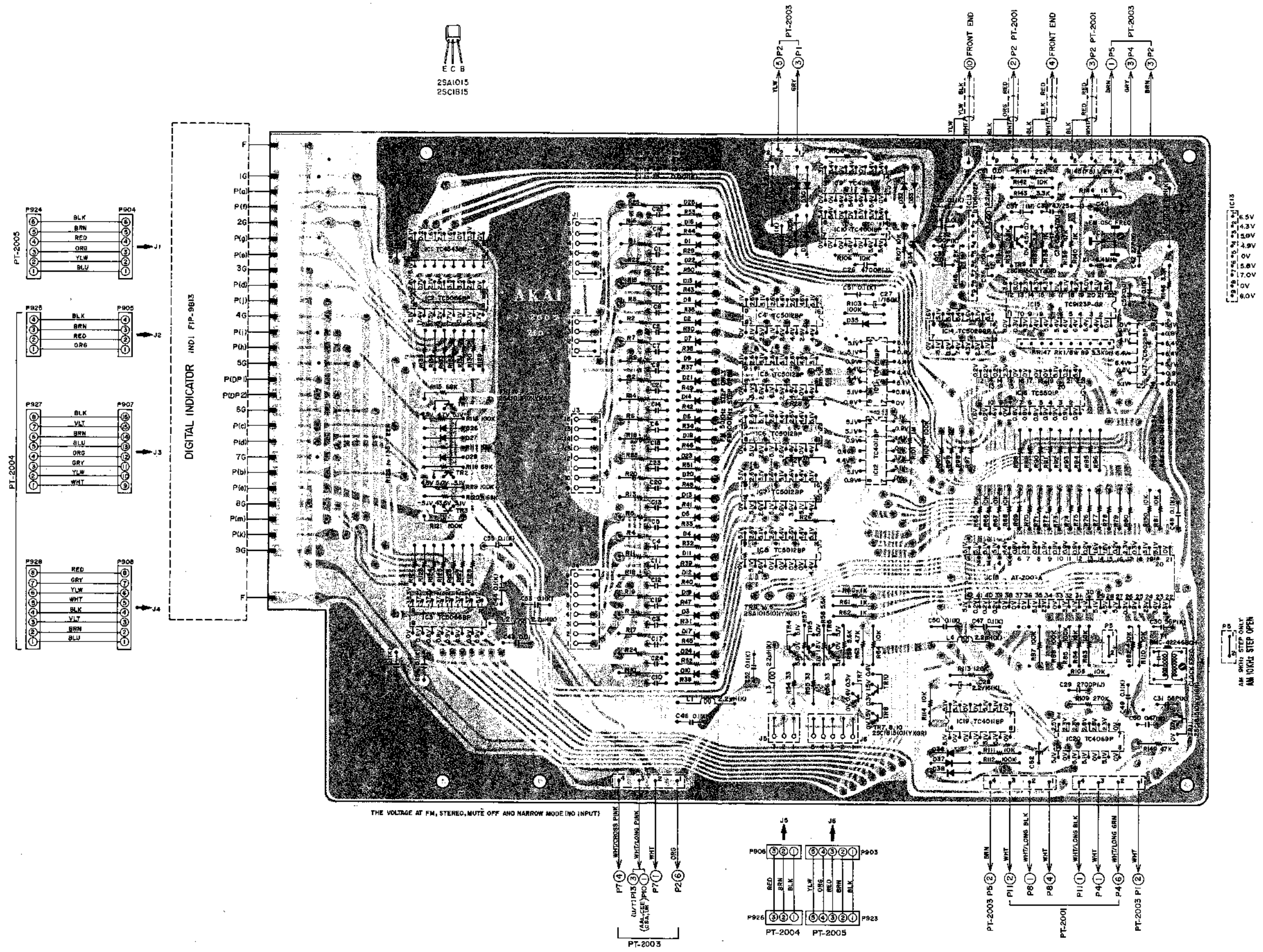

3) POWER SUPPLY P.C BOARD (2ED) PT-2003 (U/T), POWER SUPPLY P.C BOARD (2ED) PT-2048 (AAL, CSA) AND POWER SUPPLY P.C BOARD (2ED) PT-2049 (CEE, UK)

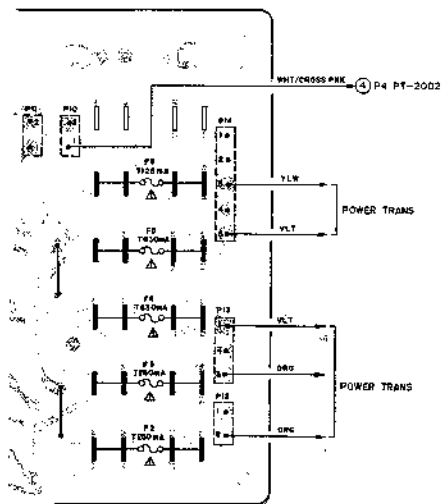
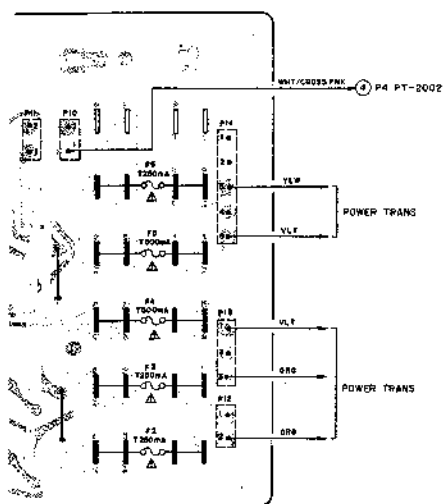
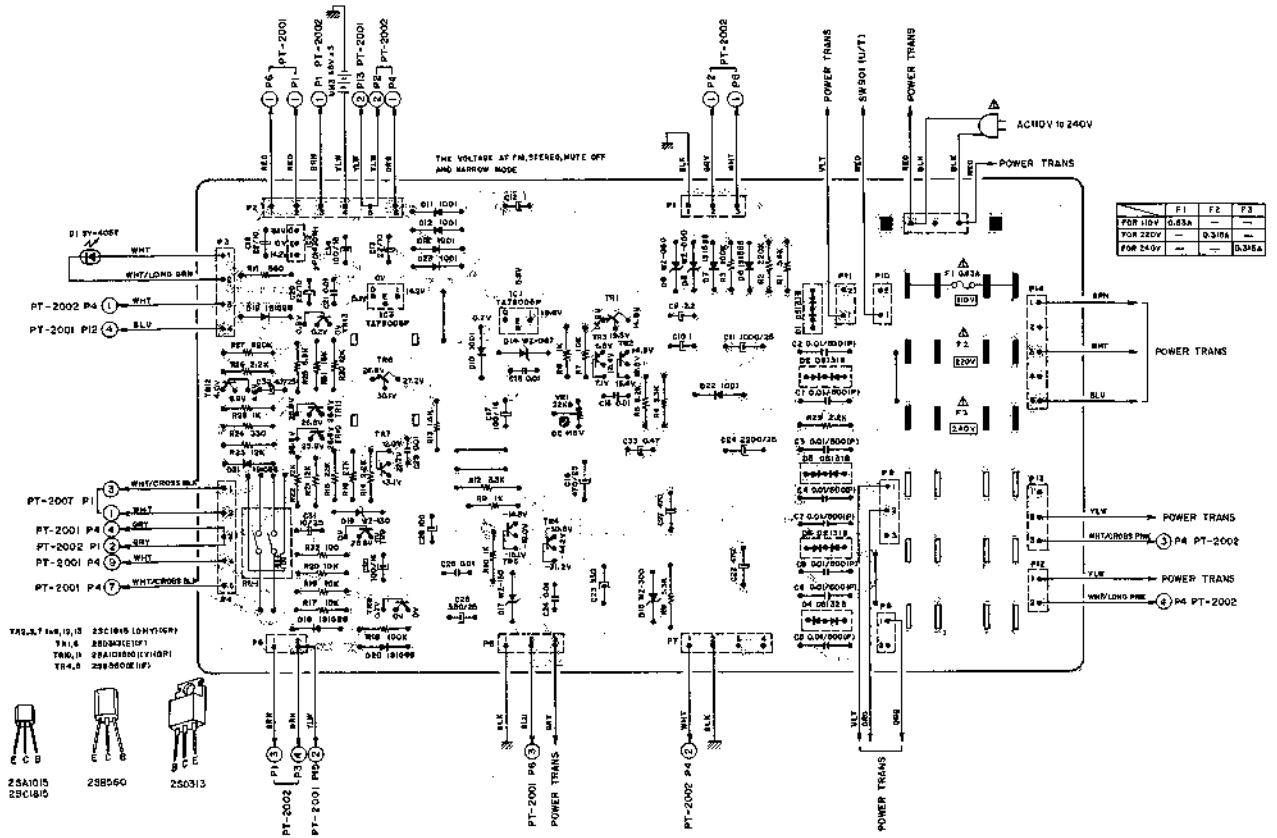

WARNING: Δ INDICATES SAFETY CRITICAL COMPONENTS. FOR CONTINUED SAFETY, REPLACE SAFETY CRITICAL COMPONENTS ONLY WITH MANUFACTURER'S RECOMMENDED PARTS

AVERTISSEMENT: Δ IL INDU LES COMPOSANTS CRITIQUES DE SURETE. POUR MAINTENIR LE DEGRE DE SECURITE DE L'APPAREIL, NE REMPLACER LES COMPOSANTS OBT LE FONCTIONNEMENT EST CRITIQUE POUR LA SECURITE QUE PAR DES PIECES RECOMMENDEES PAR LE FABRICANT

4) FUSE P.C BOARD PT-2045 (AAL, CSA) AND FUSE P.C BOARD PT-2050 (CEE, UK)

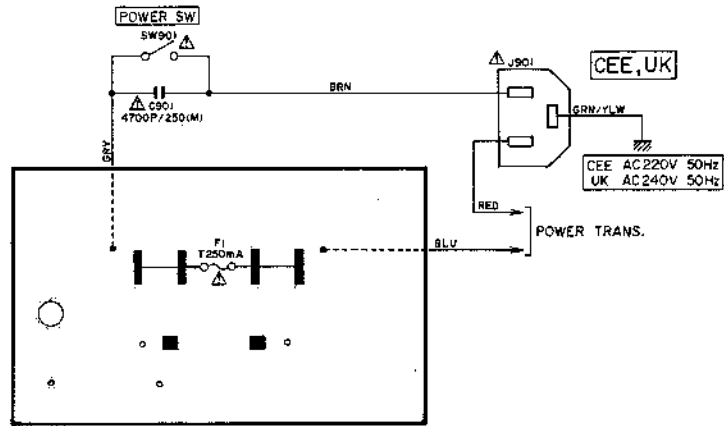
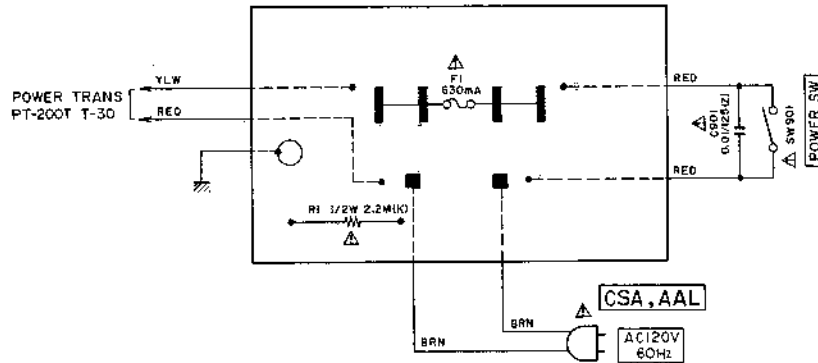

WARNING: ⚠ INDICATES SAFETY CRITICAL COMPONENTS. FOR CONTINUED SAFETY, REPLACE SAFETY CRITICAL COMPONENTS ONLY WITH MANUFACTURER'S RECOMMENDED PARTS
 AVERTISSEMENT: ⚠ IL INDIQUE LES COMPOSANTS CRITIQUES DE SÛRETÉ. POUR MAINTENIR LE DEGRÉ DE SÛRETÉ DE L'APPAREIL, NE REMPLACER LES COMPOSANTS DONT LE FONCTIONNEMENT EST CRITIQUE POUR LA SÛRETÉ QUE PAR DES PIÈCES RECOMMANDÉES PAR LE FABRICANT

5) TOUCH P.C BOARD (A) PT-2004

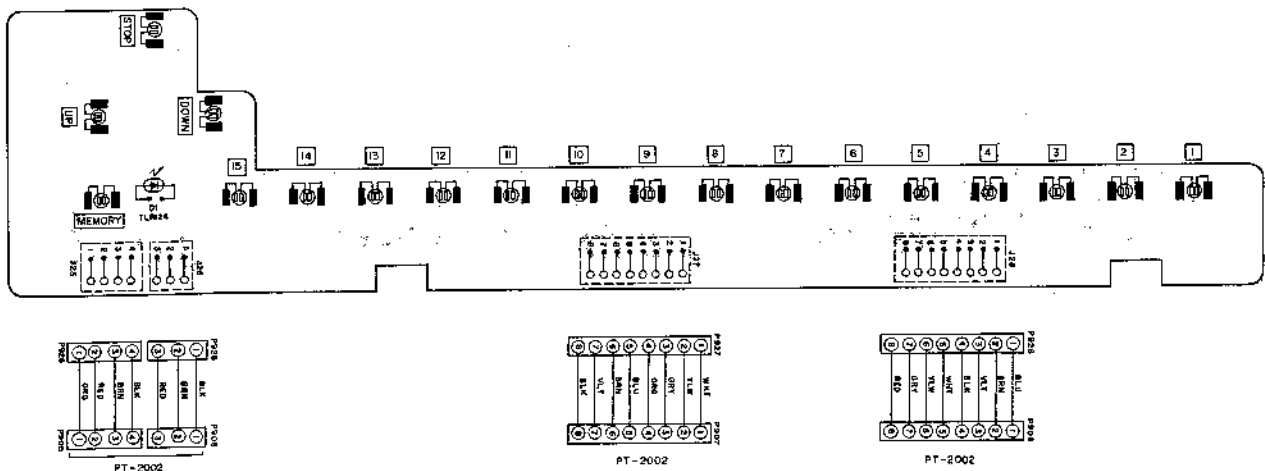

6) TOUCH P.C BOARD (B) PT-2005

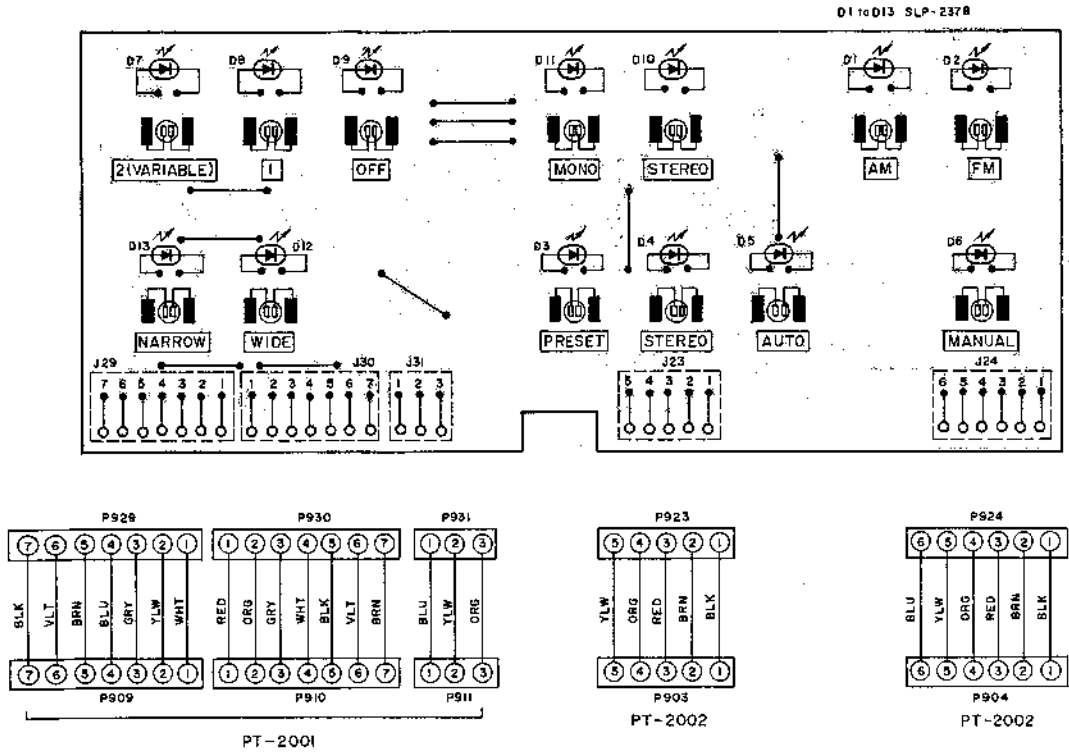

7) LED P.C BOARD PT-2006

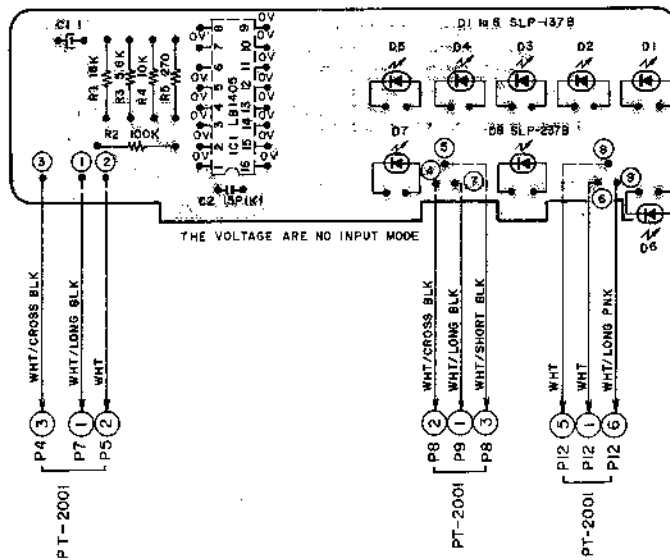

8) VOLUME P.C BOARD PT-2007

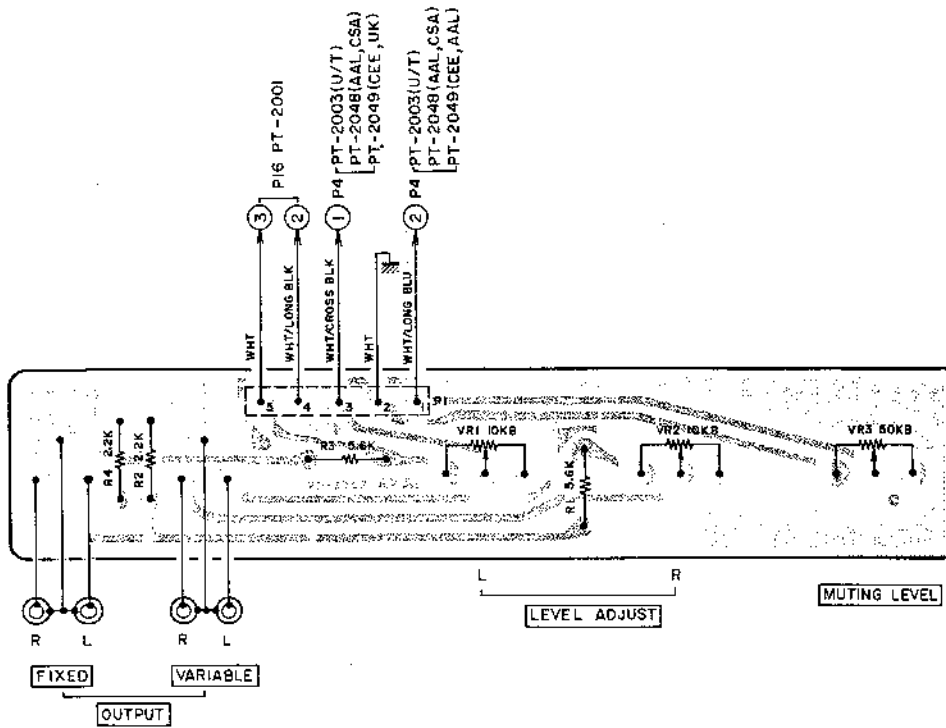

9) FILTER P.C BOARD ATS-8038

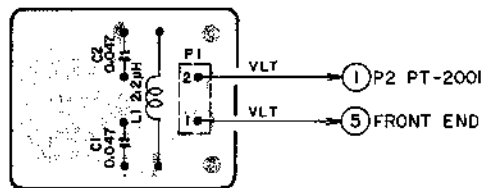

SECTION 2

PARTS LIST

TABLE OF CONTENTS

1. RECOMMENDED SPARE PARTS LIST	32
2. TUNER P.C BOARD (PT-2001) BLOCK	34
3. SYNTHESIZER P.C BOARD (PT-2002/J) BLOCK	35
4. POWER SUPPLY P.C BOARD (PT-2003) BLOCK	35
5. ASSEMBLY BLOCK	36
6. FINAL ASSEMBLY BLOCK	38
INDEX	39

Resistor and Capacitor which is not listed in this parts list, please refer to COMMON LIST FOR SERVICE PARTS.

HOW TO USE THIS PARTS LIST

1. This parts list is compiled by various individual blocks based on assembly process.
2. When ordering parts, please describe parts number, serial number, and model number in detail.
3. How to read List

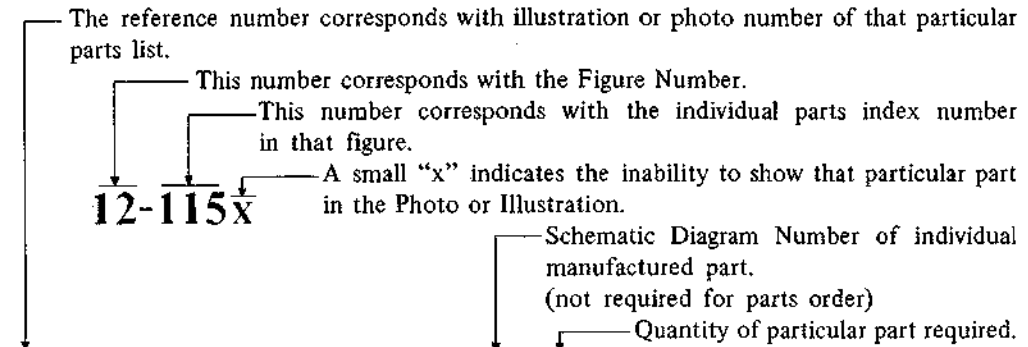

Ref. No.	Parts No.	Description	Schematic No.	Q'ty
FLYWHEEL BLOCK #13				
12-115x	800425	Flywheel Block Assy. Comp.	RDG #13	1
12-116	244506	Flywheel Only	RD-233	1
12-117x	244754	Felt, Flywheel	RD-275	1
12-118	251324	Main Metal Case	RD-236	1
12-119	253080	Main Metal	RD-237	1

4. The symbol numbers shown on the P.C. Board list can be matched with the Composite Views of Components of the Schematic Diagram or Service Manual.
5. Please utilize separate "Common List for Service Parts" for Resistor Parts orders.
6. The shape of the parts and parts name, etc. can be confirmed by comparing them with the parts shown on the Electrical Parts Table of P.C. Board.
7. Both the kind of part and installation position can be determined by the Parts Number. To determine where a parts number is listed, utilize Parts Index at end of Parts List.
It is necessary first of all to find the Parts Number. This can be accomplished by using the Reference Number listed at right of parts number in the Parts Index. (meaning of ref. no. outlined in Item 3 above).
8. Utilize separate "Price List for Parts" to determine unit price. The most simple method of finding parts Price is to utilize the reference number.

- CAUTION:**
1. When placing an order for parts, be sure to list the parts no. model no., and description. There are instances in which if any of this information is omitted, parts cannot be shipped or the wrong parts will be delivered.
 2. Please be careful not to make a mistake in the parts no. If the parts no. is in error, a part different from the one ordered may be delivered.
 3. Because parts number and parts unit supply in the Preliminary Service Manual (Basic Parts List) may be partially changed, please use this parts list for all future reference.

WARNING

▲ INDICATES SAFETY CRITICAL COMPONENTS. FOR CONTINUED SAFETY, REPLACE SAFETY CRITICAL COMPONENTS ONLY WITH MANUFACTURER'S RECOMMENDED PARTS.

AVERTISSEMENT:

▲ IL INDIQU LES COMPOSANTS CRITIQUES DE SURETE. POUR MAINTENIR LE DEGRE DE SECURITE DE L'APPAREIL NE REMPLACER LES COMPOSANTS DONT LE FONCTIONNEMENT EST CRITIQUE POUR LA SECURITE QUE PAR DES PIECES RECOMMANDEES PAR LE FABRICANT.

AC INLET SYSTEM

This model is equipped with an AC INLET SYSTEM. Please refer to the AC INLET SYSTEM CHART below for the specific type. By the AC INLET SYSTEM, AC (mains) cord can be connected to and disconnected from the model because the model is provided with socket exclusively for AC (mains) cord on its main body.

Please note, however, that certain models are not equipped with this system and has a built-in AC (mains) cord as before.

AC INLET SYSTEM CHART

CLASS I

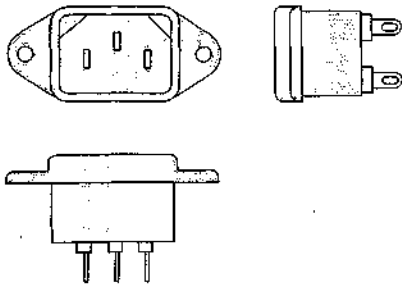

Picture 1
AC INLET
to be
installed
on machines

CLASS II

☐ This mark indicating double insulation will be attached to machine's rear panel

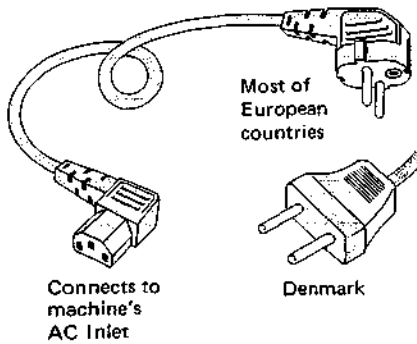
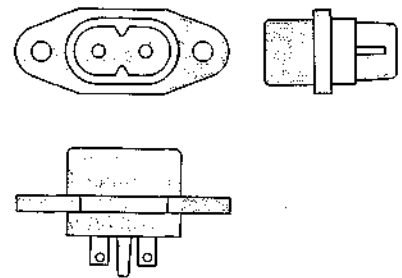

Picture 2
AC (mains)
cord

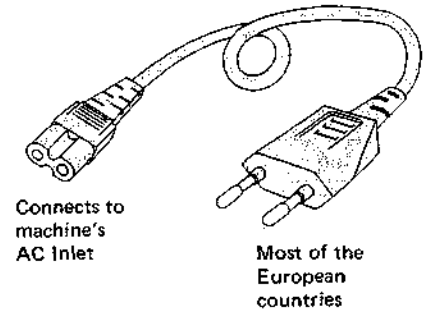

U.K.

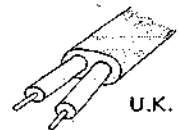

U.K.

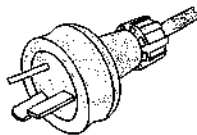

Australia
differs according
to wall socket

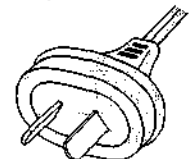

Australia
differs according
to wall socket

Parts List for AC (mains) Cord Set

	Standard	Description	Type of AC Inlet	Parts No.
Class I	CEE	Cord Set CEE (3 cores)	3P	EW302993
	BEAB	Cord Set BEAB (3 cores)	3P	EW302994
	SAA	Cord Set SAA (3 cores)	3P	EW302996
	U/T	Cord Set U/T (3 cores)	3P	EW302646
Class II	CEE	Cord Set CEE (2 cores)	2P	EW638144
	BEAB	Cord Set BEAB (2 cores)	2P	EW302995
	SAA	Cord Set SAA (2 cores)	2P	EW302991
	U/T	Cord Set U/T (2 cores)	2P	EW302899

1. RECOMMENDED SPARE PARTS LIST

Because, if the parts listed below are on hand, almost any repair can be accomplished, we suggest that you stock these Recommended Spare Parts Items.

Parts No.	Description	Note
BA314502	Power Supply P.C Board Comp. PS-200T (U/T)	U/T
BA313954	Power Supply P.C Board Comp. PS-200T (CEE)	CEE, UK
BA314503	Power Supply P.C Board Comp. PS-200T (CSA)	CSA, AAL
BA314513	Synthesizer P.C Board Comp. PS-200T	
BA314511	Tuner P.C Board Comp. PS-200T	
BT315357	△ Power Trans. PS-200TT-30	CSA, AAL
BT315359	△ Power Trans. PS-200TT-40	CEE
BT315360	△ Power Trans. PS-200TT-50	UK
BT315249	△ Power Trans. PS-200TT-70	U/T
EC616342	Trimmer/C. CTY-15D33 15PF	
EC315346	Trimmer/C. ECV-1ZW 50X32E	
ED219464	Germanium Diode 1N34A	
ED311856	LED SLP1378	
ED315361	LED SLP237B	
ED311794	LED SY405T	
ED315498	LED TLR124	
ED315365	Silicon Diode DS131B	
ED315366	Silicon Diode DS132B	
ED557447	Silicon Diode 1S1588	
ED315411	Vari Cap Diode SVC-311-AB	
ED315367	Zener Diode WZ-050	
ED315368	Zener Diode WZ-067	
ED539976	Zener Diode WZ-130	
ED315372	Zener Diode WZ-300	
EE315248	Front End VFT-51EH-22	
EF315334	△ Fuse 250MA 125V	CSA, AAL
EF306125	△ Fuse 315MA 250V	U/T
EF305703	△ Fuse 630MA 125V	CSA, AAL
EF306124	△ Fuse 630MA 250V	U/T
EF300574	△ Fuse (EAWK) 125MAT	CEE, UK
EF300586	△ Fuse (EAWK) 250MAT	CEE, UK
EF593706	△ Fuse (SEMKO T Type) 500MAT	CEE, UK
EI315388	Crystal OSC 6.4MHz	
EI315311	IC HA11223W	
EI650586	IC LA-1230	
EI293185	IC LA-1240	
EI315491	IC LB1405S	
EI573838	IC TA7060P	
EI306703	IC TA75458P	
EI315243	IC TA78005P	
EI304657	IC TC4011BP	

Parts No.	Description	Note
EI304657	IC TC4011BP	
EI304657	IC TC4011BP	
EI315312	IC TC4023BP	
EI306726	IC TC4069BP	
EI315378	IC TC4543BP	
EI315380	IC TC5012BP	
EI315383	IC TC5029BP	
EI315379	IC TC5066BP	
EI315385	IC TC5501P	
EI315384	IC TC9123PYSTU	
EI315381	IC TD6102P	
EI315387	IC TMP4315P	
EI299441	IC TA7303P (C)	
EI313797	IC TC4001BP	
EI313797	IC TC4001BP	
EP249344	Reed Relay, L Type L24	
ES310839	△ Push SW. SDG-1P	CEE, UK
ES655806	△ Push SW. SDG-1P	U/T
ES656335	△ Slide SW. SSB02210	U/T, CSA, AAL
ES665875	△ Push SW. SDG1P-J TV-3 UL/CSA	CSA, AAL
ET315313	FET 2SK19 (GR)	
ET315313	FET 2SK19 (GR)	
ET491051	FET 2SK30A (GR)	
ET552870	FET 2SK30A (Y) (GR)	
ET315410	FET 2SK61 (Y)	
ET308867	Transistor 2SA1015 (O) (Y) (GR)	
ET623790	Transistor 2SA640 (E) (F)	
ET305221	Transistor 2SC1815 (O) (Y) (GR)	
ET305221	Transistor 2SC1815 (O) (Y) (GR)	
ET618873	Transistor 2SC930 (E) (F)	
ET452531	Transistor 2SD313 (E) (F)	
ET310148	Transistor 2SD612K (E) (F)	
TA315369	Digital Display FIP-9B13	

2. TUNER P.C BOARD (PT-2001) BLOCK

Symbol No.	Parts No.	Description	Schematic No.	Symbol No.	Parts No.	Description	Schematic No.
2-1	BA314511	Tuner P.C Board Comp. PS-200T	PT-2056	2-VR5	EV483388	Semi-Fixed/Vol. (Solid Type) SR19R 10KB	36-19-10
2-1C1,2	EI573838	IC TA7060P	45-8-97	2-VR6	EV380215	Semi-Fixed/Vol. (Solid Type) SR19R 100KB	36-19-10
2-1C3	EI299441	IC TA7303P(C)	45-8-216	2-VR7,8	EV315318	Semi-Fixed/Vol. (Solid Type) SR19R 220KB	36-19-10
2-1C4	EI650586	IC LA-1230	45-8-152	2-VR9	EV551452	Semi-Fixed/Vol. (Solid Type) SR19R 22kB	36-19-10
2-1C5	EI306703	IC TA75458P	45-8-309	2-VR10	EV427858	Semi-Fixed/Vol. (Solid Type) SR19R 4.7KB	36-19-10
2-1C6	EI293185	IC LA-1240	45-8-220	2-VR11	EV551452	Semi-Fixed/Vol. (Solid Type) SR19R 22KB	36-19-10
2-1C7,8	EI306703	IC TA75458P	45-8-309	2-VC1,2	EC616342	Trimmer/C. CTY-1 5D33 15PF	24-2-32
2-1C9	EI315311	IC HA11223W	45-8-353	2-FL1	ER315314	Ceramic Filter SAF10.7ME5-A	53-1-170
2-1C10	EI304657	IC TC4011BP	45-8-232	2-FL2	ER315406	Ceramic Filter SFE10.7ML(KA)	53-1-167
2-1C11	EI313797	IC TC4001BP	45-8-348	2-FL3to5	ER315407	Ceramic Filter SFE10.7MM(KA)	53-1-168
2-1C12	EI304657	IC TC4011BP	45-8-232	2-FL6to8	ER315408	Ceramic Filter SFA10.7MF(5)	53-1-169
2-1C13	EI315312	IC TC4023BP	45-8-361	2-FL9	ER315409	Ceramic Filter CFM2-460AL	53-1-174
2-TR1to3	ET618873	FET 2SK930(E)(F)	45-1-185	2-FL10,11	ER315315	Low Pass Filter 208BLR-3217N	23-1-325
2-TR4,5	ET315313	FET 2SK19(GR)	45-12-3	2-T1	BT315397	FM-IF Trans. P154AC-40715X	23-1-323
2-TR6,7	ET305221	Transistor 2SC1815(O)(Y)(GR)	45-1-299	2-T2	BT315316	FM-IF Trans. M127CC-20032A	23-1-324
2-TR8	ET552870	FET 2SK30A(Y)(GR)	45-12-4	2-T3	BT299575	FM-IF Trans. 154AC-41345Z	23-1-274
2-TR10	ET305221	Transistor 2SC1815(O)(Y)(GR)	45-1-299	2-T4	EO314963	DET Coil TKAEA-26480AUO	23-1-327
2-TR11	ET308867	Transistor 2SA1015(O)(Y)(GR)	45-1-328	2-T5	EO314964	DET Coil TKAEA-26482X	23-1-328
2-TR12to23	ET305221	Transistor 2SC1815(O)(Y)(GR)	45-1-299	2-T6	EO315398	AM-ANT Coil RWR-43854N	23-1-316
2-TR24	ET552870	FET 2SK30A(Y)(GR)	45-12-4	2-T7	EO315399	AM-RF Coil 7BR-4958N	23-1-317
2-TR25to28	ET305221	Transistor 2SC1815(O)(Y)(GR)	45-1-299	2-T8	EO315400	AM-OSC Coil RWR-43653N	23-1-318
2-TR29	ET310148	Transistor 2SD612K(E)(F)	45-1-308	2-T9	EO315401	AM-IF Coil CFMA-014	23-1-319
2-TR30,31	ET315313	FET 2SK19(GR)	45-12-3	2-T10	EO315402	AM-IF Coil TMC-4781Y	23-1-320
2-TR32to34	ET618873	Transistor 2SC930(E)(F)	45-1-185	2-T11	EO315403	AM-IF Coil TMC-4783Y	23-1-321
2-TR35to40	ET305221	Transistor 2SC1815(O)(Y)(GR)	45-1-299	2-T12	BT293398	AM-IF Trans. RMC-42246BCH 468 kHz	23-1-276
2-TR41,42	ET623790	Transistor 2SA640(E)(F)	45-1-102	2-L1to4	EO539820	Peaking Coil 2.2μH(K)	23-1-187
2-TR43	ET305221	Transistor 2SC1815(O)(Y)(GR)	45-1-299	2-L5	EO650610	Inductor 144LZ 18μH(J)	23-1-240
2-TR44	ET310148	Transistor 2SD612K(E)(F)	45-1-308	2-L6,7	EO380564	Ferri Inductor FL7H 1.8MH(J)	23-1-3
2-TR45	ET305221	Transistor 2SC1815(O)(Y)(GR)	45-1-299	2-L8	EO315405	Inductor 144LZ 10μH(J)	23-1-240
2-TR46	ET308867	Transistor 2SA1015(O)(Y)(GR)	45-1-328	2-L9	EO539820	Peaking Coil 2.2μH(K)	23-1-187
2-TR47	ET305221	Transistor 2SC1815(O)(Y)(GR)	45-1-299	2-J1	EJ315305	Connector (Bottom Entry Type) 163681-1	31-4-29
2-TR48	ET310148	Transistor 2SD612K(E)(F)	45-1-308	2-J2,3	EJ315309	Connector (Bottom Entry Type) 163681-5	31-4-29
2-TR49	ET305221	Transistor 2SC1815(O)(Y)(GR)	45-1-299	2-R64	ER308849	Carbon/R. (Homing Type) F 1/4W 220 ohms(J)	35-11-25
2-TR50	ET308867	Transistor 2SA1015(O)(Y)(GR)	45-1-328	2-R85	ER308849	Carbon/R. (Homing Type) F 1/4W 220 ohms(J)	35-11-25
2-TR51to54	ET552870	FET 2SK30A(Y)(GR)	45-12-4	2-R100	ER308849	Carbon/R. (Homing Type) F 1/4W 220 ohms(J)	35-11-25
2-TR55to61	ET308867	Transistor 2SA1015(O)(Y)(GR)	45-1-328	2-R103	ER308849	Carbon/R. (Homing Type) F 1/4W 220 ohms(J)	35-11-25
2-TR62	ET491051	FET 2SK30A(GR)	45-12-4	2-R121	ER308849	Carbon/R. (Homing Type) F 1/4W 220 ohms(J)	35-11-25
2-TR63	ET305221	Transistor 2SC1815(O)(Y)(GR)	45-1-299	2-R162	ER307196	Carbon/R. F 1/4W 100 ohms(J)	35-11-25
2-TR64	ET315410	FET 2SK61(Y)	45-12-24	2-FR1	ER561216	Fuse/R. 1/4W 100 ohms(K) 200MA	35-14-9
2-TR65	ET305221	Transistor 2SC1815(O)(Y)(GR)	45-1-299	2-C59	EC317129	Styrol/C. 430PF(G) 50WV	24-11-14
2-D1,2	ED219464	Germanium Diode 1N34A	45-3-1	2-C89	EC315327	Styrol/C. (w/Rubber) 1000PF(J) 50WV	24-11-13
2-D3to7	ED557447	Silicon Diode 1S1588	45-3-22				
2-D8,9	ED219464	Germanium Diode 1N34A	45-3-1				
2-D10to23	ED557447	Silicon Diode 1S1588	45-3-22				
2-D24,25	ED219464	Germanium Diode 1N34A	45-3-1				
2-D26to39	ED557447	Silicon Diode 1S1588	45-3-22				
2-D40to42	ED315411	Vari Cap Diode SVC-311-AB	45-3-54				
2-D43,44	ED557447	Silicon Diode 1S1588	45-3-22				
2-D45	ED219464	Germanium Diode 1N34A	45-3-1				
2-D46,47	ED557447	Silicon Diode 1S1588	45-3-22				
2-VR1	EV361800	Semi-Fixed/Vol. (Solid Type) SR19R 470 ohmB	36-19-10				
2-VR2,3	EV483377	Semi-Fixed/Vol. (Solid Type) SR19R 47kB	36-19-10				
2-VR4	EV551452	Semi-Fixed/Vol. (Solid Type) SR19R 22kB	36-19-10				

When ordering parts, please describe Parts Number, Description, and Model Number in detail.

3. SYNTHESIZER P.C BOARD (PT-2002/J) BLOCK

Symbol No.	Parts No.	Description	Schematic No.
3-1	BA314513	Synthesizer P.C Board Comp. PS-2000T	PT-2055
3-IC1	EI31 5378	IC TC4543BP	45-8-354
3-IC2,3	EI31 5379	IC TC5066BP	45-8-355
3-IC4to8	EI31 5380	IC TC5012BP	45-8-356
3-IC9	EI304657	IC TC4011BP	45-8-232
3-IC10	EI31 3797	IC TC4001BP	45-8-348
3-IC11,12	EI304657	IC TC4011BP	45-8-232
3-IC13	EI31 5381	IC TD6102P	45-8-362
3-IC14	EI31 5383	IC TC5029BP	45-8-358
3-IC15	EI31 5384	IC TC9123PYSTU	45-8-359
3-IC16	EI31 5385	IC TC5501P	45-8-360
3-IC17	EI31 5383	IC TC5029BP	45-8-358
3-IC18	EI31 5387	IC TMP4315P	45-8-363
3-IC19	EI304657	IC TC4011BP	45-8-232
3-IC20	EI306726	IC TC4069BP	45-8-263
3-TR1to6	ET308867	Transistor 2SA1015(O)(Y)(GR)	45-1-328
3-TR7to11	ET305221	Transistor 2SC1815(O)(Y)(GR)	45-1-299
3-D1to38	ED557447	Silicon Diode 1S1588	45-3-22
3-J1	EJ31 5308	Connector (Bottom Entry Type) 163681-4	31-4-29
3-J2	EJ31 5306	Connector (Bottom Entry Type) 163681-2	31-4-29
3-J3,4	EJ31 5310	Connector (Bottom Entry Type) 163681-6	31-4-29
3-J5	EJ31 5305	Connector (Bottom Entry Type) 163681-1	31-4-29
3-J6	EJ31 5307	Connector (Bottom Entry Type) 163681-3	31-4-29
3-J12,13	EJ31 5370	22P LSI Socket	31-1-243
3-J4	EJ31 5377	42P LSI Socket	31-1-244
3-X1	EI31 5388	Crystal OSC 6.4MHz	53-1-171
3-T1	BT293398	AM-IF Trans. RMC-42246BCH 468 kHz	23-1-276
3-L1to7	EO539820	Peaking Coil 2.2μH(K)	23-1-187
3-VC1	EC31 5346	Trimmer/C. ECV-1ZW 50X32E	24-2-48
3-C26	EC31 5390	Styrol/C. 4700PF(J) 50WV	24-11-14
3-C27	EC305445	Tantalum/C. (D Type) 1μF(M) 16WV	24-15-12
3-C28	EC301432	Solid Aluminum/C. (Vert. Type) 2.2μF(K) 16V	24-19-2
3-C29	EC31 5348	Styrol/C. (Horm. Type) 2700PF(J) 50WV	24-11-14
3-C37	EC31 3532	NP/C. (Homing Type) 1μF(M) 50WV	24-17-31
3-R145	ER31 5389	Carbon/R. F1/2W 4700HMS(J)	35-11-27

4. POWER SUPPLY P.C BOARD (PT-2003) BLOCK

Symbol No.	Parts No.	Description	Schematic No.
4-1	BA314502	Power Supply P.C Board Comp. PS-200T (U/T)	PT-2054
4-2	BA314503	Power Supply P.C Board Comp. PS-200T (CSA) (AAL)	PT-2054
4-3	BA31 3954	Power Supply P.C Board Comp. PS-200T (CEE) (UK)	PT-2054
4-IC1	EI315243	IC TA78005P	45-8-364
4-IC2	EI31 5364	IC UPC14308	45-8-352
4-IC3	EI315243	IC TA78005P	45-8-364
4-TR1	ET452531	Transistor 2SD313(E)(F)	45-1-105
4-TR2,3	ET305221	Transistor 2SC1815(O)(Y)(GR)	45-1-299
4-TR4,5	ET21 9868	Transistor 2SB560(E)(F)	45-1-332
4-TR6	ET452531	Transistor 2SD313(E)(F)	45-1-105
4-TR7to9	ET305221	Transistor 2SC1815(O)(Y)(GR)	45-1-299
4-TR10,11	ET308867	Transistor 2SA1015(O)(Y)(GR)	45-1-328
4-TR12,13	ET305221	Transistor 2SC1815(O)(Y)(GR)	45-1-299
4-D1to3	ED31 5365	Silicon Diode DS131B	45-3-55
4-D4	ED31 5366	Silicon Diode DS132B	45-3-56
4-D5	ED31 5365	Silicon Diode DS131B	45-3-55
4-D6,7	ED557447	Silicon Diode 1S1588	45-3-22
4-D8,9	ED31 5367	Zener Diode WZ-050	45-6-87
4-D10to13	ED224526	Silicon Diode 10D1	45-2-11
4-D14	ED31 5368	Zener Diode WZ-067	45-6-87
4-D15	ED31 5372	Zener Diode WZ-300	45-6-87
4-D16	ED539976	Zener Diode WZ-130	45-6-87
4-D17	ED237960	Zener Diode WZ-150	45-6-87
4-D18to21	ED557447	Silicon Diode 1S1588	45-3-22
4-D22,23	ED224526	Silicon Diode 10D1	45-2-11
4-VR1	EV551452	Semi-Fixed/Vol. (Solid Type) SR19R 22kB	36-19-10
4-RL1	EP249344	Reed Play, L Type L24	47-2-28
4-C1to8	EC204671	△ Ceramic/C. DD31-6E 0.01μF(P) 500WV	24-5-66
4-C11	EC450270	Elect./C. (Vert. Type) 1000μF 25WV	24-12-9
4-C14	EC657966	Elect./C. (Vert. Type) 2200μF 25WV	24-12-9
4-4	ZS421740	Screw, Pan Head 3x8 (Black)	
4-5	ZS447761	Tapping Screw, #2 BR 3x6 (Black)	

5. ASSEMBLY BLOCK

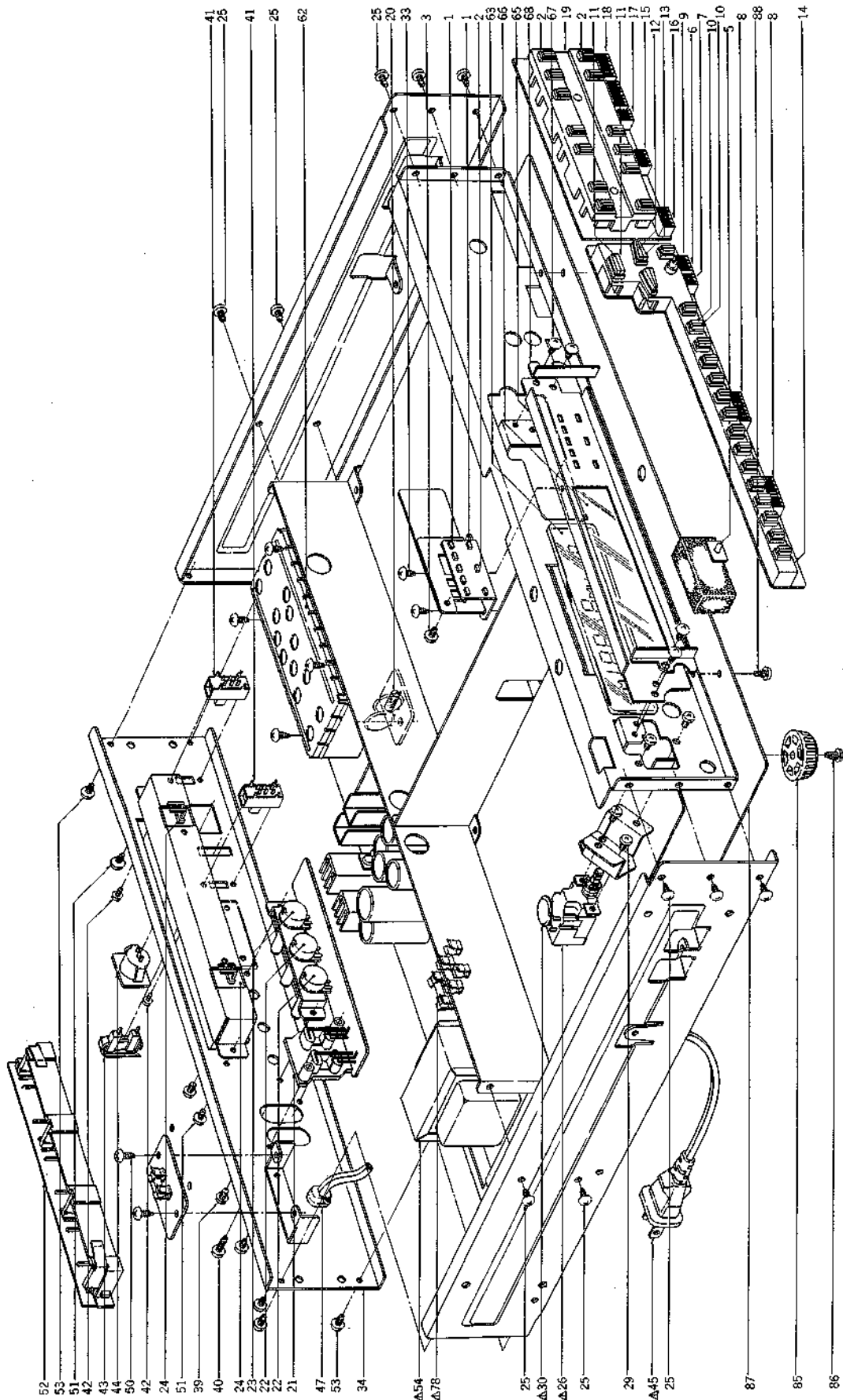

5. ASSEMBLY BLOCK

Ref. No.	Parts No.	Description	Schematic No.	Ref. No.	Parts No.	Parts Name	Schematic No.
LED P.C BOARD BLOCK							
5-1	ED311856	LED SLP137B	45-15-23	5-42	ZS608185	Screw, Pan 2.6x4 (Black)	
5-2	ED315361	LED SLP237B	45-15-28	5-43	EJ315244	AM Antenna Socket	
5-3	ZS463353	Tapping Screw, #2 BR 3x8 (Black)				CS080-01-020	31-1-242
5-4	EI315491	I.C LB1405S	45-8-385	5-44	EJ315333	FM Antenna Plug TCP9106-01-01	42-1-160
LED P.C BOARD (B) BLOCK							
5-5	ED311794	LED SY405T	45-15-24	5-45	EW306428	Δ AC Cord (U/T)	26-3-64
TOUCH P.C BOARD (A) BLOCK							
5-6	EJ315306	Connector (Bottom Entry Type) 163681-2	31-4-29	5-46x	EW305691	Δ AC Cord CUL (CSA, AAL)	26-3-65
5-7	EJ315305	Connector (Bottom Entry Type) 163681-1	31-4-29	5-47	EZ631945	Strain Relief SR-4N-4 (U/T, CSA, AAL)	2-7-49
5-8	EJ315310	Connector (Bottom Entry Type) 163681-6	31-4-29	5-48x	EJ296853	Δ 3P In-let CM-3 (CEE, UK)	31-1-199
5-9	ED315498	LED TLR124	45-15-29	5-49	ZS463353	Tapping Screw, #2 BR 3x8 (Black) (CEE, UK)	
5-10	SZ315286	Touch Piece (A)	PT-2041	5-50	ZS463353	Tapping Screw, #2 BR 3x8 (Black) (CSA, AAL, CEE, UK)	
5-11	SZ315287	Touch Piece (B)	PT-2042	5-51	ZS463353	Tapping Screw, #2 BR 3x8 (Black)	
5-12	SZ315288	Touch Piece (C)	PT-2043	5-52	TA314294	Battery Case Assy PS-200T	13-2-64
5-13	SZ315289	Touch Piece (D)	PT-2044	5-53	ZS308846	Tapping Screw #2, 3x8 (BR) (Oval Neck)	7-1-69
5-14	SZ315284	Touch Base (A)	PT-2039	5-54	BT315249	Δ Power Trans. PS-200TT-70 (U/T)	38-4-723
TOUCH P.C BOARD (B) BLOCK							
5-15	EJ315307	Connector (Bottom Entry Type) 163681-3	31-4-29	5-55x	BT315357	Δ Power Trans. PS-200TT-30 (CSA, AAL)	38-4-720
5-16	EJ315308	Connector (Bottom Entry Type) 163681-4	31-4-29	5-56x	BT315359	Δ Power Trans. PS-200TT-40 (CEE)	38-4-721
5-17	EJ315305	Connector (Bottom Entry Type) 163681-1	31-4-29	5-57x	BT315360	Δ Power Trans. PS-200TT-50 (UK)	38-4-722
5-18	EJ315309	Connector (Bottom Entry Type) 163681-5	31-4-29	5-58x	ZS411232	Screw, Binding Head 4x10	
5-19	SZ315285	Touch Base (B)	PT-2040	5-59x	ZW237857	Washer D4.1x10x11	
FILTER P.C BOARD BLOCK							
5-20	EO539820	Peaking Coil 2.2μH(K)	23-1-187	5-60x	ZW273914	Spring Washer, M4	
VOL. P.C BOARD BLOCK							
5-21	EJ293365	4P Pin Jack	31-1-197	5-61x	ZW413188	Nut M4, #1	
5-22	EV315493	Vol. VM10R 10kB	36-6-40	5-62	EE-315248	Front End VFT-51EH-22	57-2-52
5-23	EV315495	Vol. VM10R 50kB	36-6-41	5-63	TA315369	Digital Display FIP-9B13	53-1-173
BATTERY P.C BOARD BLOCK							
5-24	BA314383	Battery P.C Board Comp. AT-S08	ATS-9072	5-64x	ZS312419	Screw, Pan 4x8 w/Washer (Black) (CEE, UK)	
ASSEMBLY BLOCK							
5-25	ZS308846	Tapping Screw #2, 3x8 (BR) (Oval Neck)	7-1-69	5-65	TA315258	Panel	PT-2016,2017
5-26	ES655806	Δ Push SW. SDG1P-J TV3 CSA (U/T)	25-5-187	5-66	SZ315259	Indication Plate	PT-2018
5-27x	ES665875	Δ Push SW. SDG-1P U/L (CSA, AAL)	25-5-199	5-67	ZS447761	Tapping Screw, #2 BR 3x6 (Black)	
5-28x	ES310839	Δ Push SW. SDG1P-E SA/80A 250V (CEE, UK)	25-5-310	5-68	TA315260	Mask	PT-2020
5-29	ZS355522	Screw, Pan Head 3x6 (Black)		5-69x	EJ315340	5P Connector Assy	26-6-337
5-30	EC204671	Δ Ceramic/C. DD31-6E 0.01μF(P) 500WV (U/T)	24-5-66	5-70x	EJ315341	6P Connector Assy	26-6-338
5-31x	EC314688	Δ Ceramic/C. DE7150 FZ 0.01μF(P) 125WV (CSA, AAL)	24-5-67	5-71x	EJ315339	4P Connector Assy	26-6-336
5-32x	EC301320	Δ MP/C. 4700PF(M) 250WV (CEE, UK)	24-9-122	5-72x	EJ315338	3P Connector (2) Assy	26-6-335
5-33	ZS311745	Tapping Screw #2, 3x8 (BR) W=8 (Black)		5-73x	EJ315344	8P Connector (1) Assy	26-6-341
5-34	SP315265	Rear Panel (U/T)	PT-2024	5-74x	EJ315345	8P Connector (2) Assy	26-6-342
5-35x	SP315267	Rear Panel (CSA)	PT-2024	5-75x	EJ315342	7P Connector (1) Assy	26-6-339
5-36x	SP315266	Rear Panel (AAL)	PT-2024	5-76x	EJ315343	7P Connector (2) Assy	26-6-340
5-37x	SP315269	Rear Panel (CEE)	PT-2025	5-77x	EJ315337	3P Connector (1) Assy	26-6-334
5-38x	SP315271	Rear Panel (UK)	PT-2025	5-78	EJ306124	Δ Fuse 630MA 250V (U/T)	39-1-64
5-39	ZS355522	Screw, Pan Head 3x6 (Black)		5-79x	EF306125	Δ Fuse 315MA 250V (U/T)	39-1-64
5-40	ZS522865	Tapping Screw, #2 BR 3x12 (Black)		5-80x	EF305703	Δ Fuse 630MA 125V (CSA, AAL)	39-1-65
5-41	ES656335	Δ SLIDE SW. SSB02210 (U/T, CSA, AAL)	25-3-117	5-81x	EF315334	Δ Fuse 250MA 125V (CSA, AAL)	39-1-65
				5-82x	EF300586	Δ Fuse (EAWK) 250MAT (CEE, UK)	39-1-60
				5-83x	EF593706	Δ Fuse (SEMKO T Type) 500MAT (CEE, UK)	39-1-53
				5-84x	EF300574	Δ Fuse (EAWK) 125MAT (CEE, UK)	39-1-60
				5-85	SA311742	Circular Foot	PC-2032
				5-86	ZS311747	Tapping Screw #2, 4x8 (PAN) (Black)	
				5-87	SP315278	Bottom Plate	PT-2033
				5-88	ZS308846	Tapping Screw #2, 3x8 (BR) (Oval Neck)	7-1-69

6. FINAL ASSEMBLY BLOCK

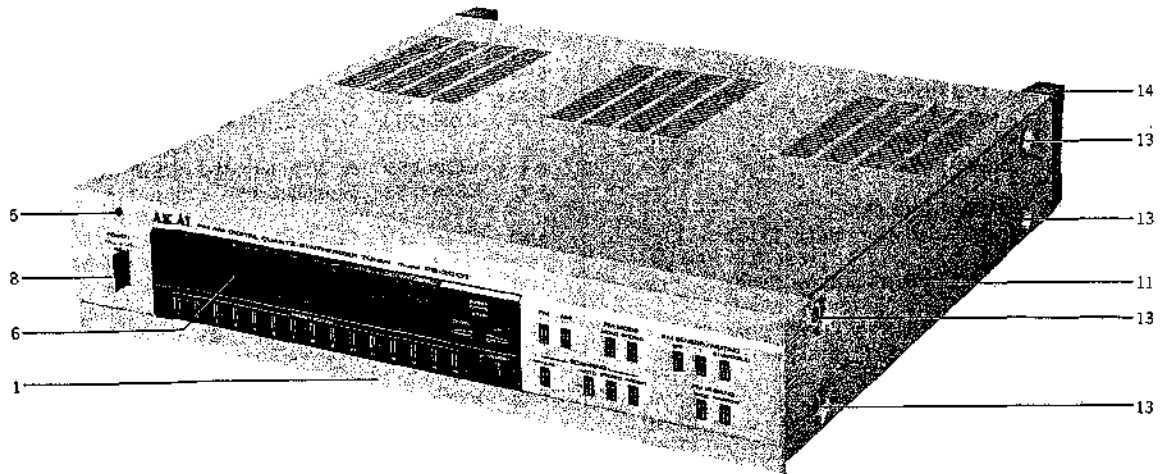

6. FINAL ASSEMBLY BLOCK

Ref. No.	Parts No.	Description	Schematic No.
6-1	BD314529	Front Panel Block PS-200T	
6-2x	BD314530	Front Panel Block PS-200T-BL	
6-3x	ZW616004	Washer D3.1x8x1t	
6-4x	ZW273756	Nut M3, #1	
6-5	SE311728	Power Lens	PC-2021
6-6	SP315282	Front Plate	PT-2036
6-7x	SE312477	Button Escutcheon	PC-2044
6-8	SB312474	Button	PC-2042
6-9x	SB312475	Button (BL)	PC-2042
6-10x	ZG312478	Spring	PC-2045
6-11	BC311730	Case	PC-2023
6-12x	BC312352	Case (BL)	PC-2023
6-13	ZS537006	Screw, Bind 4x8 (Black)	
6-14	SA311714	Foot	PC-2029
6-15x	ZS411232	Screw, Binding Head 4x10	

When ordering parts, please describe Parts Number, Description, and Model Number in detail.

INDEX

Parts No.	Ref. No. & Symbol No.	Parts No.	Ref. No. & Symbol No.	Parts No.	Ref. No. & Symbol No.	Parts No.	Ref. No. & Symbol No.
BA313954	4-3	EI313797	3-IC10	ES656335	5-41	ZS308846	5-53
BA314383	5-24	EI315243	4-IC1	ES665875	5-27x	ZS308846	5-88
BA314502	4-1	EI315243	4-IC3	ET219868	4-TR4,5	ZS311745	5-33
BA314503	4-2	EI315311	2-IC9	ET305221	2-TR6,7	ZS311747	5-86
BA314511	2-1	EI315312	2-IC13	ET305221	2-TR10	ZS312419	5-64x
BA314513	3-1	EI315364	4-IC2	ET305221	2-TR12to23	ZS355522	5-29
BC311730	6-11	EI315378	3-IC1	ET305221	2-TR25to28	ZS355522	5-39
BC312352	6-12x	EI315379	3-IC2,3	ET305221	2-TR35to40	ZS411232	5-58x
BD314529	6-1	EI315380	3-IC4to8	ET305221	2-TR43	ZS411232	6-15x
BD314530	6-2x	EI315381	3-IC13	ET305221	2-TR45	ZS421740	4-4
BT293398	2-T12	EI315383	3-IC14	ET305221	2-TR47	ZS447761	4-5
BT293398	3-T1	EI315383	3-IC17	ET305221	2-TR49	ZS447761	5-67
BT299575	2-T3	EI315384	3-IC15	ET305221	2-TR63	ZS463353	5-3
BT315249	5-54	EI315385	3-IC16	ET305221	2-TR65	ZS463353	5-49
BT315316	2-T2	EI315387	3-IC18	ET305221	3-TR7to11	ZS463353	5-50
BT315357	5-55x	EI315388	3-X1	ET305221	4-TR2,3	ZS463353	5-51
BT315359	5-56x	EI315491	5-4	ET305221	4-TR7to9	ZS522865	5-40
BT315360	5-57x	EI573838	2-IC1,2	ET305221	4-TR12,13	ZS537006	6-13
BT315397	2-T1	EI650586	2-IC4	ET308867	2-TR11	ZS608185	5-42
EC204671	4-C1to8	EJ293365	5-21	ET308867	2-TR46	ZW237857	5-59x
EC204671	5-30	EJ296853	5-48x	ET308867	2-TR50	ZW273756	6-4x
EC301320	5-32x	EJ315244	5-43	ET308867	2-TR55to61	ZW273914	5-60x
EC301432	3-C28	EJ315305	2-J1	ET308867	3-TR1to6	ZW413188	5-61x
EC305445	3-C27	EJ315305	3-J5	ET308867	4-TR10,11	ZW616004	6-3x
EC313532	3-C37	EJ315305	5-7	ET310148	2-TR29		
EC314688	5-31x	EJ315305	5-17	ET310148	2-TR44		
EC315327	2-C89	EJ315306	3-J2	ET310148	2-TR48		
EC315346	3-VC1	EJ315306	5-6	ET315313	2-TR4,5		
EC315348	3-C29	EJ315307	3-J6	ET315313	2-TR30,31		
EC315390	3-C26	EJ315307	5-15	ET315410	2-TR64		
EC317129	2-C59	EJ315308	3-J1	ET452531	4-TR1		
EC450270	4-C11	EJ315308	5-16	ET452531	4-TR6		
EC616342	2-VC1,2	EJ315309	2-J2,3	ET491051	2-TR62		
EC657966	4-C14	EJ315309	5-18	ET552870	2-TR8		
ED219464	2-D1,2	EJ315310	3-J3,4	ET552870	2-TR24		
ED219464	2-D8,9	EJ315310	5-8	ET552870	2-TR51to54		
ED219464	2-D24,25	EJ315333	5-44	ET618873	2-TR1to3		
ED219464	2-D45	EJ315337	5-77x	ET618873	2-TR32to34		
ED224526	4-D10to13	EJ315338	5-72x	ET623790	2-TR41,42		
ED224526	4-D22,23	EJ315339	5-71x	EV315318	2-VR7,8		
ED237960	4-D17	EJ315340	5-69x	EV315493	5-22		
ED311794	5-5	EJ315341	5-70x	EV315495	5-23		
ED311856	5-1	EJ315342	5-75x	EV361800	2-VR1		
ED315361	5-2	EJ315343	5-76x	EV380215	2-VR6		
ED315365	4-D1to3	EJ315344	5-73x	EV427858	2-VR10		
ED315365	4-D5	EJ315345	5-74x	EV483377	2-VR2,3		
ED315366	4-D4	EJ315370	3-J12,13	EV483388	2-VR5		
ED315367	4-D8,9	EJ315377	3-J14	EV551452	2-VR4		
ED315368	4-D14	EO314963	2-T4	EV551452	2-VR9		
ED315372	4-D15	EO314964	2-T5	EV551452	2-VR11		
ED315411	2-D40to42	EO315398	2-T6	EV551452	4-VR1		
ED315498	5-9	EO315399	2-T7	EW305691	5-46x		
ED539976	4-D16	EO315400	2-T8	EW306428	5-45		
ED557447	2-D3to7	EO315401	2-T9	EZ631945	5-47		
ED557447	2-D10to23	EO315402	2-T10	SA311714	6-14		
ED557447	2-D26to39	EO315403	2-T11	SA311742	5-85		
ED557447	2-D43,44	EO315405	2-L8	SB312474	6-8		
ED557447	2-D46,47	EO380564	2-L6,7	SB312475	6-9x		
ED557447	3-D1to38	EO539820	2-L1to4	SE311728	6-5		
ED557447	4-D6,7	EO539820	2-L9	SE312477	6-7x		
ED557447	4-D18to21	EO539820	3-L1to7	SP315265	5-34		
EE315248	5-62	EO539820	5-20	SP315266	5-36x		
EF300574	5-84x	EO650610	2-L5	SP315267	5-35x		
EF300586	5-82x	EP249344	4-RL1	SP315269	5-37x		
EF305703	5-80x	ER307196	2-R162	SP315271	5-38x		
EF306124	5-78	ER308849	2-R64	SP315278	5-87		
EF306125	5-79x	ER308849	2-R85	SP315282	6-6		
EF315334	5-81x	ER308849	2-R100	SZ315259	5-66		
EF593706	5-83x	ER308849	2-R103	SZ315284	5-14		
EI293185	2-IC6	ER308849	2-R121	SZ315285	5-19		
EI299441	2-IC3	ER315314	2-FL1	SZ315286	5-10		
EI304657	2-IC10	ER315315	2-FL10,11	SZ315287	5-11		
EI304657	2-IC12	ER315389	3-R145	SZ315288	5-12		
EI304657	3-IC9	ER315406	2-FL2	SZ315289	5-13		
EI304657	3-IC11,12	ER315407	2-FL3to5	TA314294	5-52		
EI304657	3-IC19	ER315408	2-FL6to8	TA315258	5-65		
EI306703	2-IC5	ER315409	2-FL9	TA315260	5-68		
EI306703	2-IC7,8	ER561216	2FR1	TA315369	5-63		
EI306726	3-IC20	ES310839	5-28x	ZG312478	6-10x		
EI313797	2-IC11	ES655806	5-26	ZS308846	5-25		

SECTION 3

SCHEMATIC DIAGRAM

1. PS-200T NO. 4-1 1581642A CONNECTION DIAGRAM
2. PS-200T NO. 4-2 1581643A SYNTHESIZER SCHEMATIC DIAGRAM
3. PS-200T NO. 4-3 1581644A TUNER SCHEMATIC DIAGRAM
4. PS-200T NO. 4-4 1581645A POWER SUPPLY SCHEMATIC DIAGRAM

LA-1230

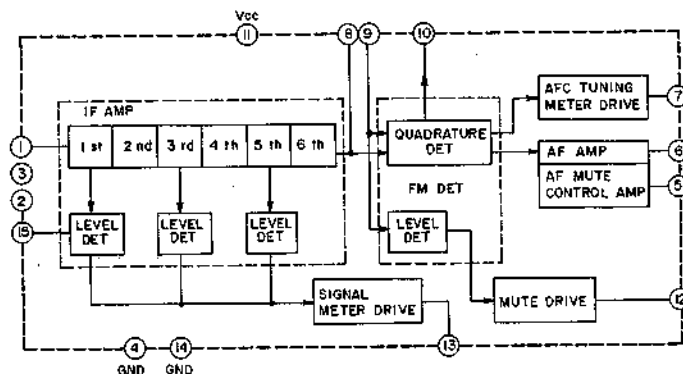

LA-1240

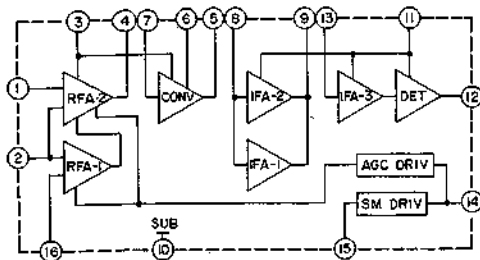

TA7060P

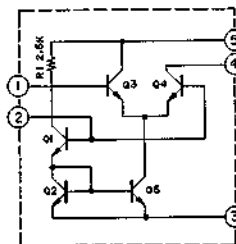

TA7303P (C)

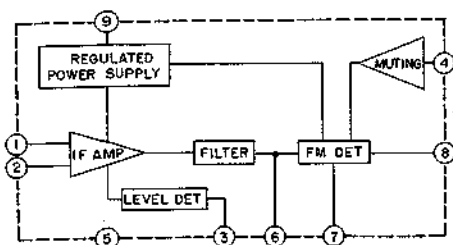

TA75458P

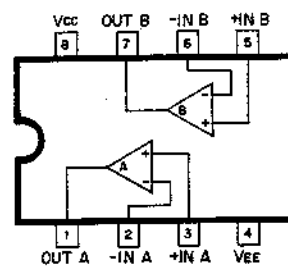

TA78005P

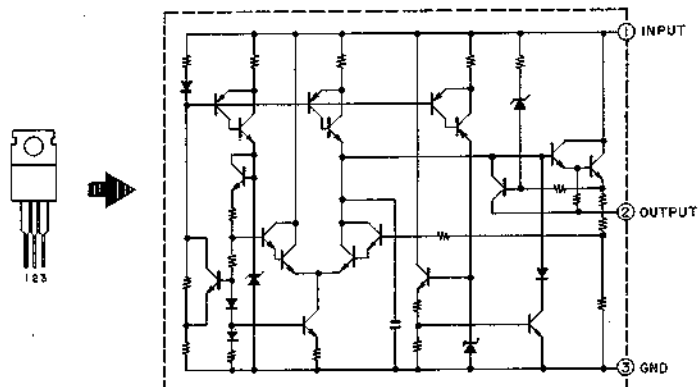

TC4001BP

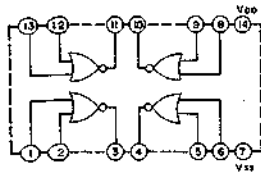

TC4011BP

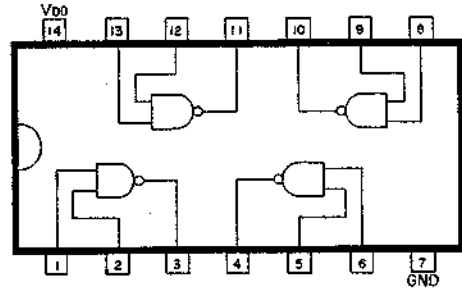

TC4023BP

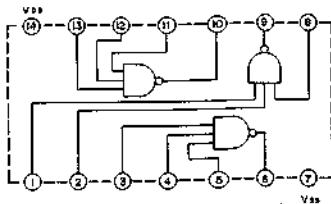

TC4069P

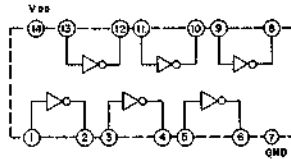

TC5012BP

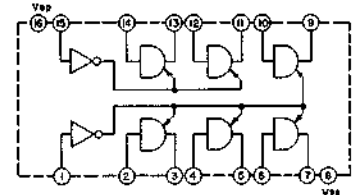

TC5501P

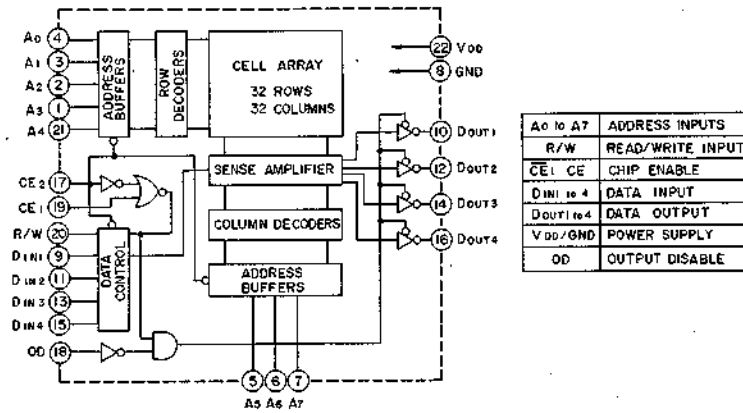

TC9123P-GR

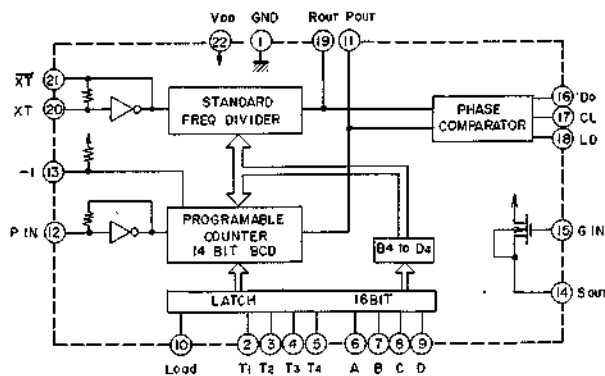

TD6102P

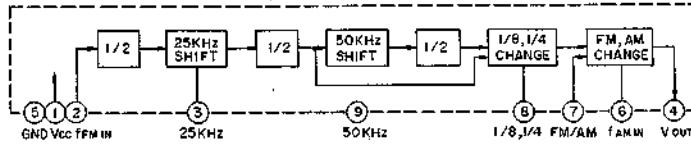

μPC14308H

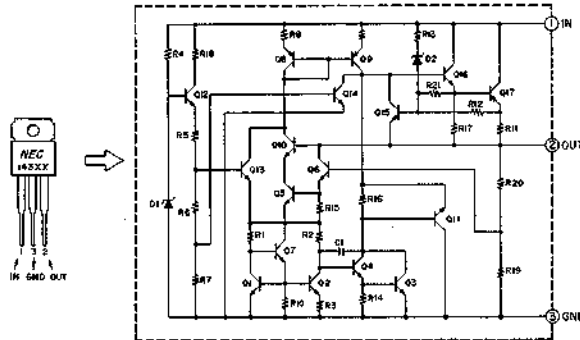

HA11233W

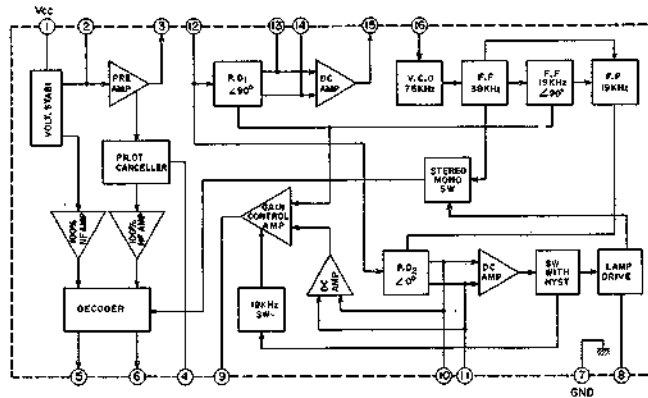

TC5066BP

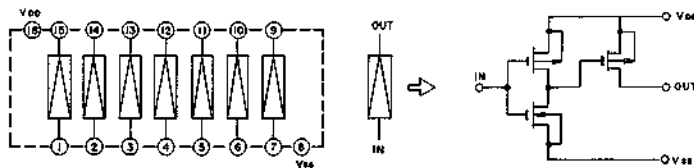

TC5029BP

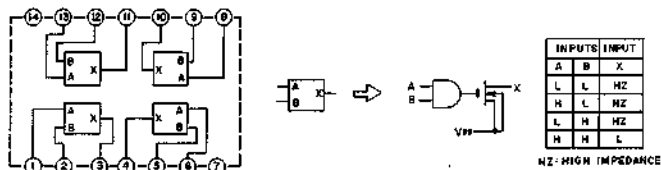

TC4543BP

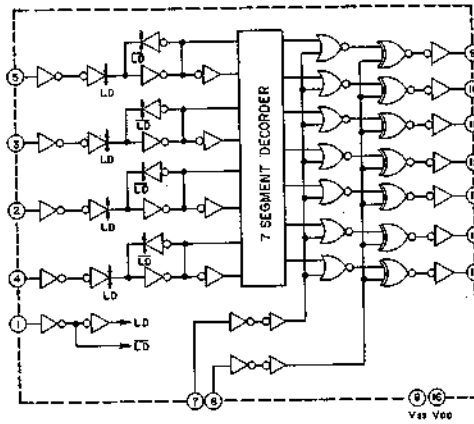

AT-200A

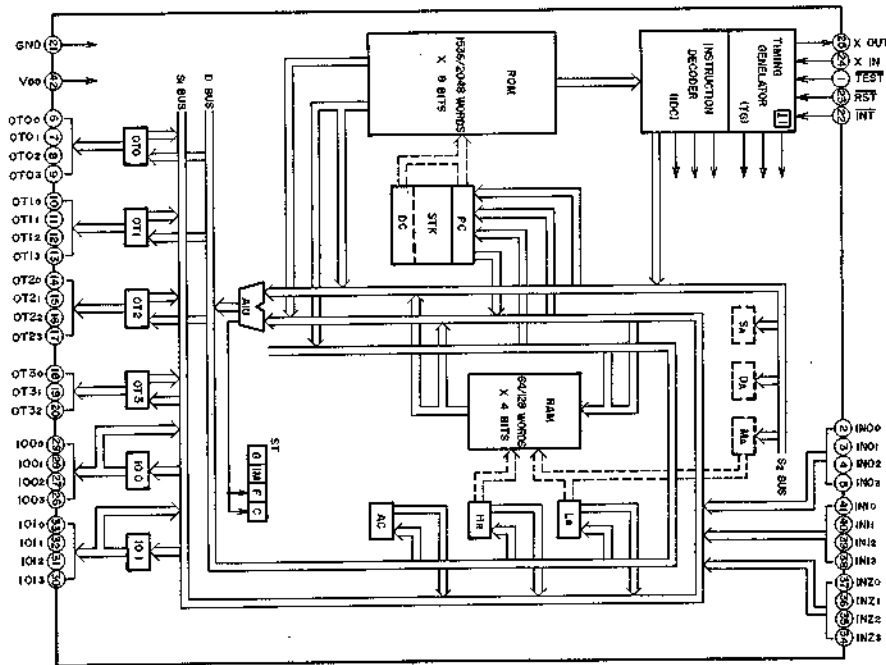

LB1405S

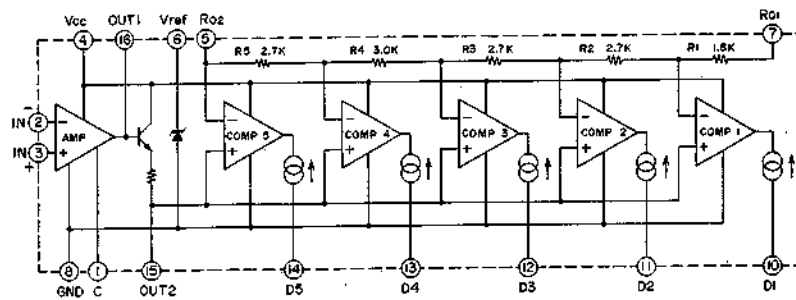

PS-200T

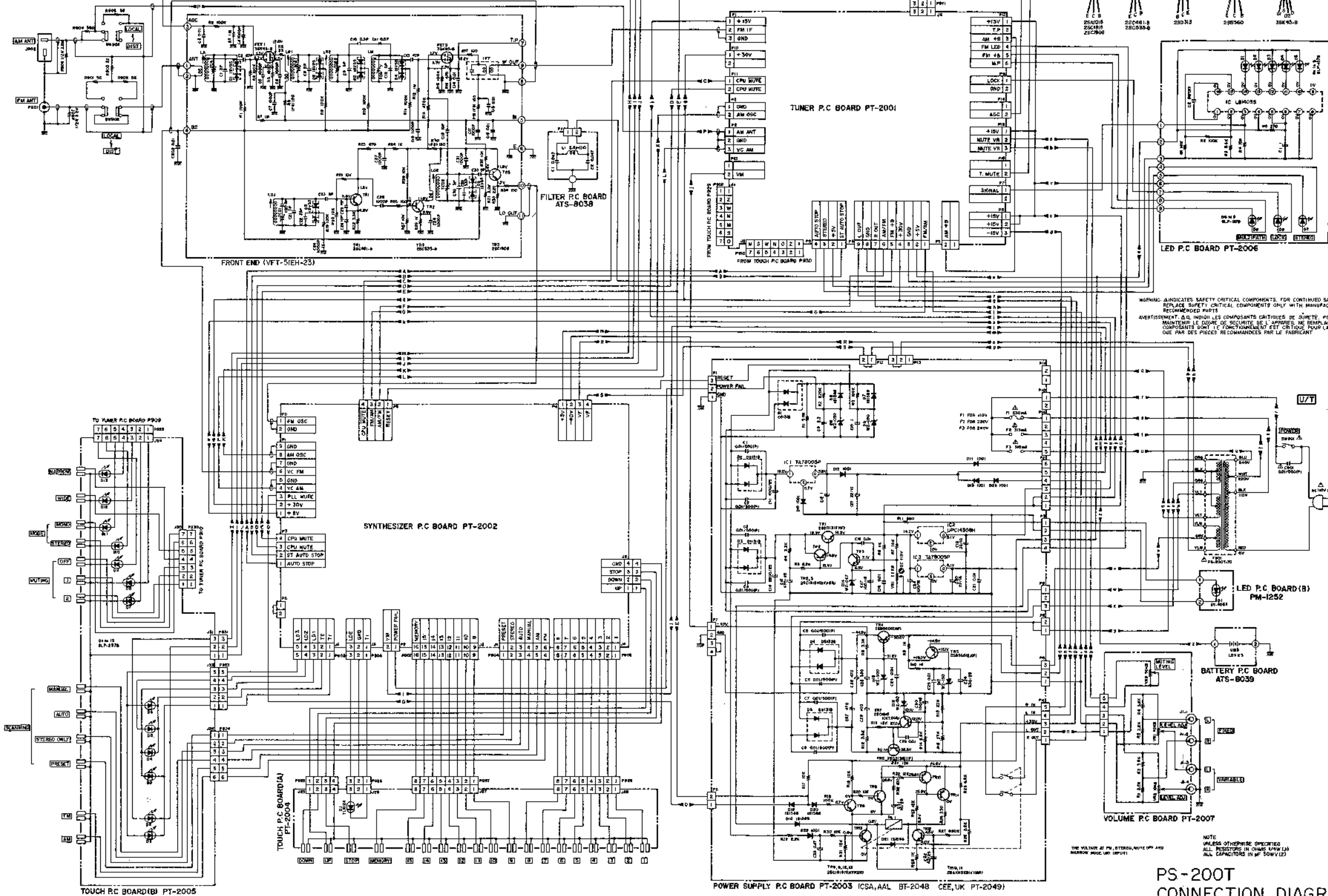

WARNING: INDICATES SAFETY CRITICAL COMPONENTS. FOR CONTINUED SAFETY, REPLACE SAFETY CRITICAL COMPONENTS ONLY WITH MANUFACTURER'S RECOMMENDED PARTS.
 AVERTISSEMENT: IL INDIQUE LES COMPOSANTS CRITIQUES DE SÛRETÉ. POUR MAINTENIR LE COEFF. DE SÛRETÉ DE L'APPAREIL, NE REMPLACER LES COMPOSANTS SÛR ET SÛR QUE CEUX QUI SONT CRITIQUES POUR LA SÛRETÉ QUE PAR DES PIÈCES RECOMMANDÉES PAR LE FABRICANT.

PS-200T
 CONNECTION DIAGRAM
 NO. 4-1 1581642A
 2C

001034B

PS-200T

SYNTHESIZER P.C BOARD PT-2002

DIGITAL INDICATOR IND1 FIP-9813

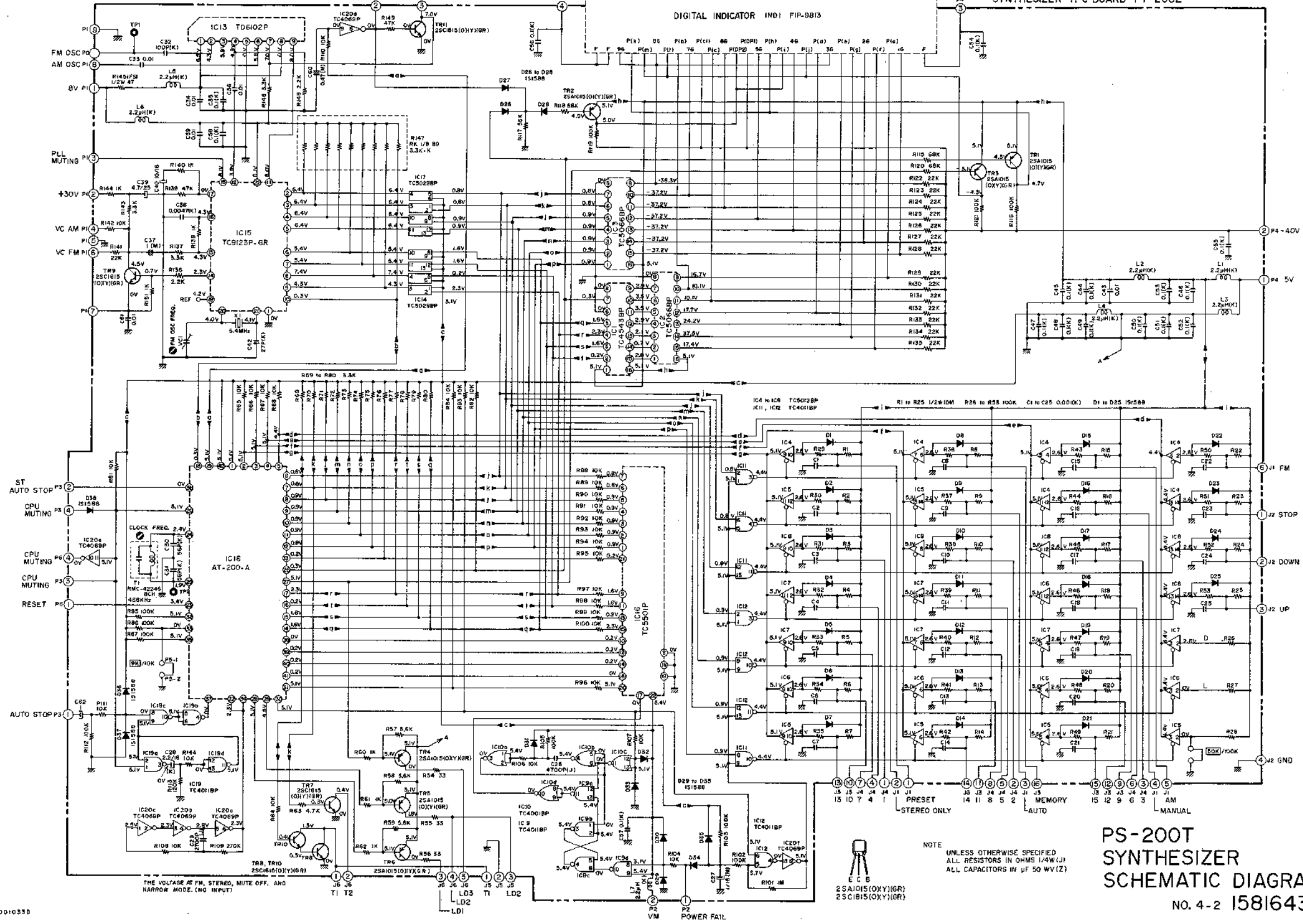

THE VOLTAGE AT FM, STEREO, MUTE OFF, AND NARROW MODE. (NO INPUT)

NOTE
UNLESS OTHERWISE SPECIFIED
ALL RESISTORS IN OHMS (1/4W/1%)
ALL CAPACITORS IN μ F 50 WV(2)

PS-200T
SYNTHESIZER
SCHEMATIC DIAGRAM
NO. 4-2 1581643A

0010330

20

PS-200T

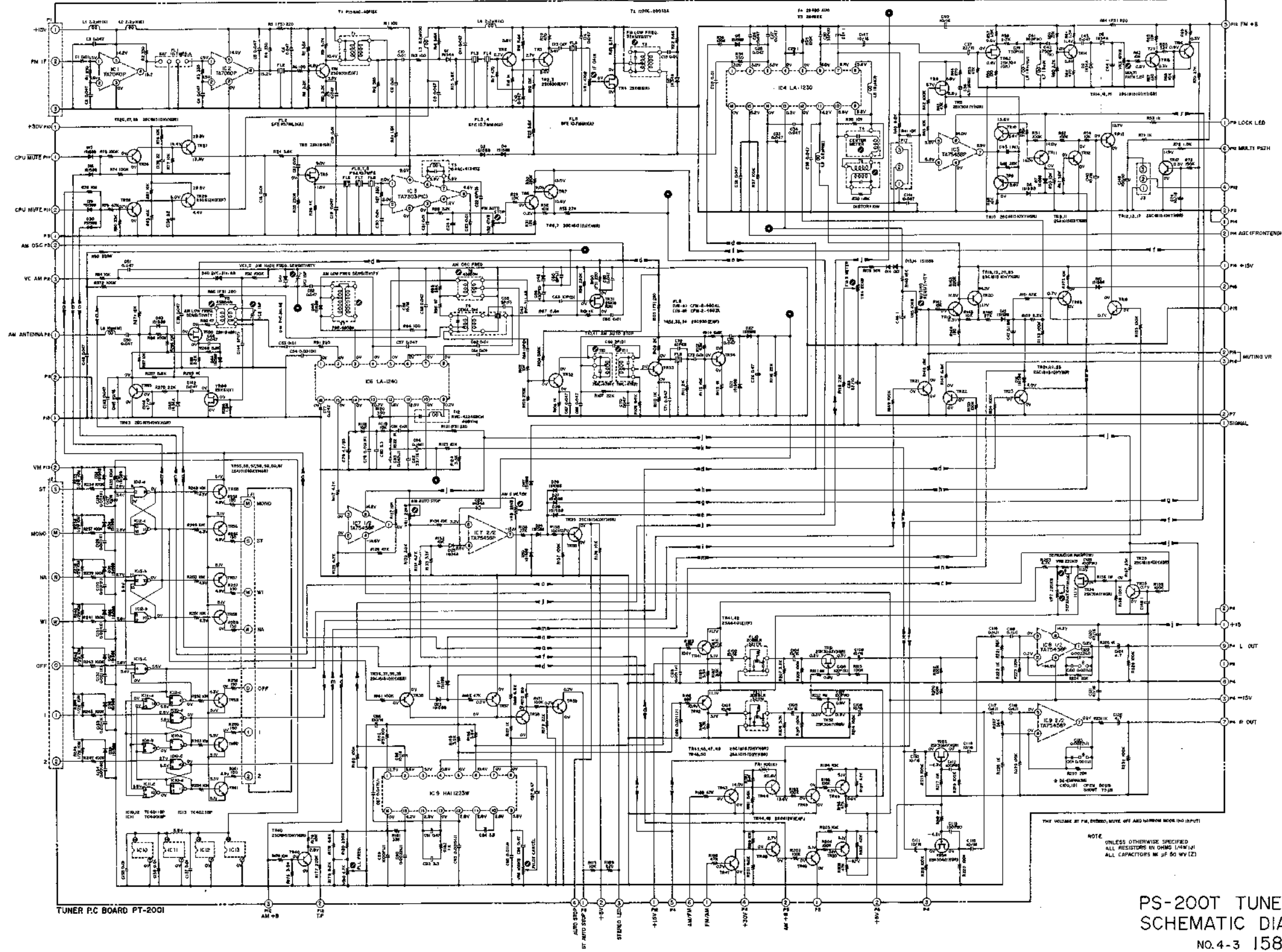

PS-200T TUNER
SCHEMATIC DIAGRAM
NO. 4-3 1581644A
9C

001032E

PS-200T

CSA, AAL

CEE, UK

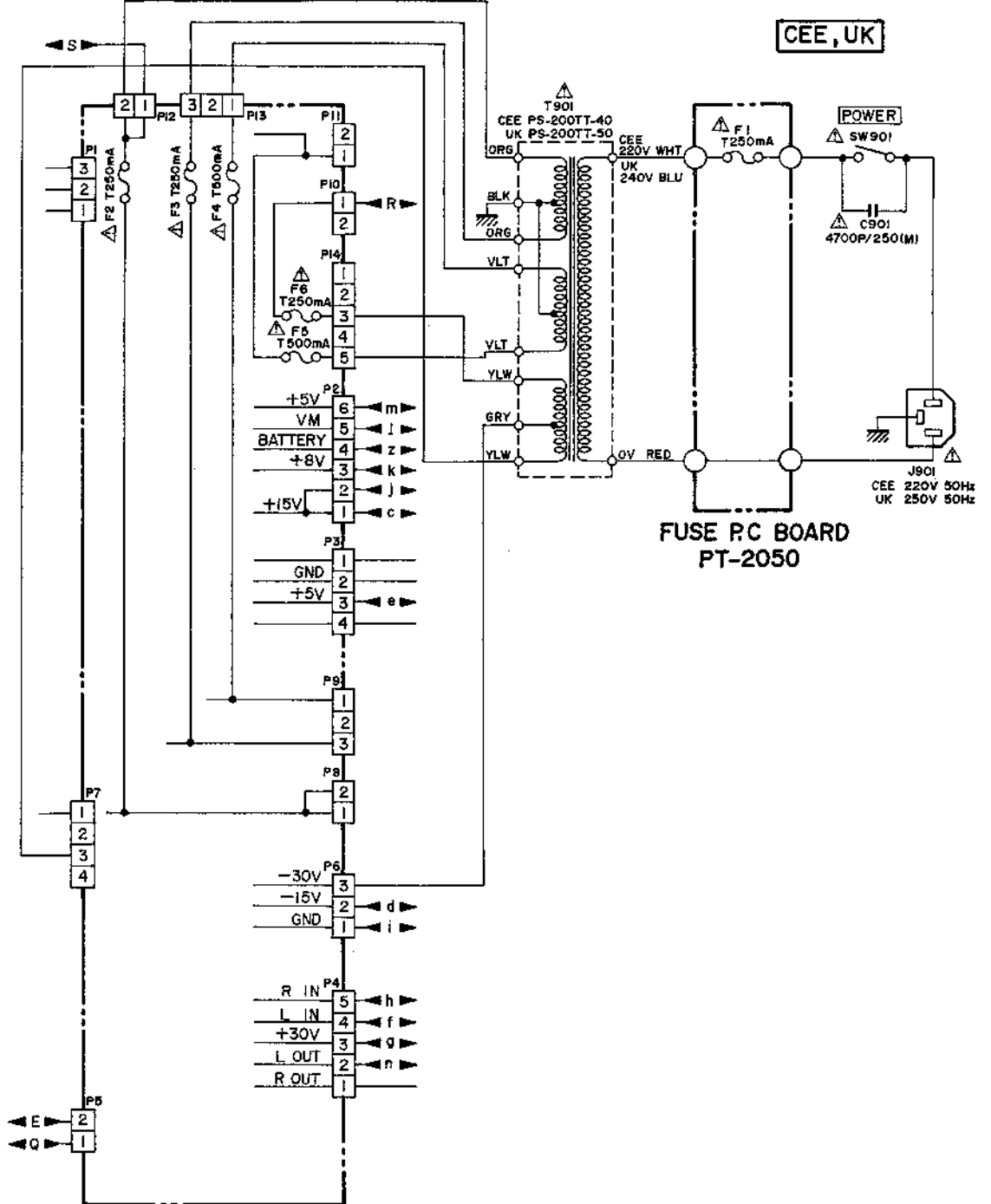
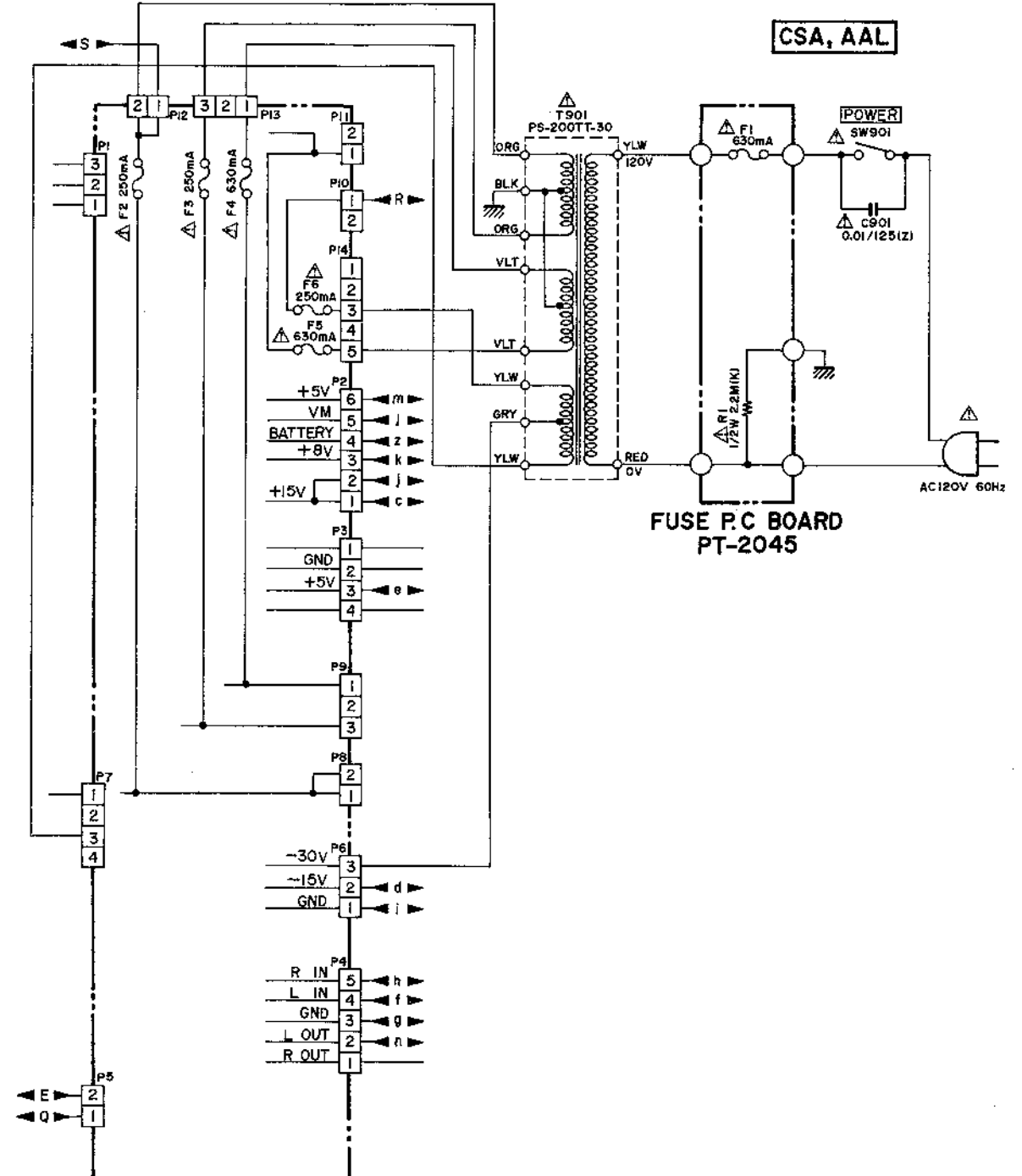

WARNING: Δ INDICATES SAFETY CRITICAL COMPONENTS. FOR CONTINUED SAFETY, REPLACE SAFETY CRITICAL COMPONENTS ONLY WITH MANUFACTURER'S RECOMMENDED PARTS.
 AVERTISSEMENT: Δ IL INDIQUE LES COMPOSANTS CRITIQUES DE SÛRETÉ. POUR MAINTENIR LE DEGRÉ DE SÛRETÉ DE L'APPAREIL, NE REMPLACEZ LES COMPOSANTS DONT LE FONCTIONNEMENT EST CRITIQUE POUR LA SÛRETÉ QUE PAR DES PIÈCES RECOMMANDÉES PAR LE FABRICANT.

PS-200T
 POWER SUPPLY
 SCHEMATIC DIAGRAM
 NO. 4-4 1581645A

001037A

2C