

SERVICE MANUAL

PS-200C
PS-120M
PS-200M

MODEL PS-200C
PS-120M
PS-200M

AKAI

ALSO APPLICABLE TO BLACK PANEL MODEL.



PS-200C

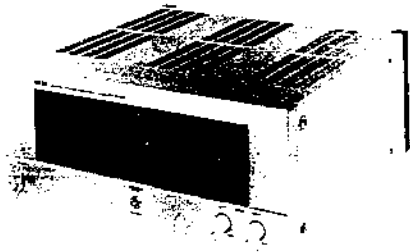

PS-120M

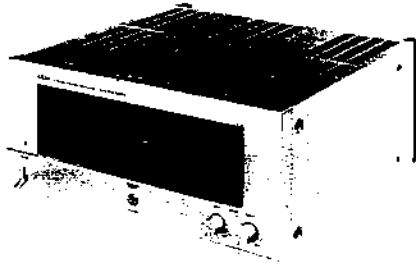

PS-200M

**STEREO PRE-AMPLIFIER
and
STEREO POWER AMPLIFIERS**

**PS-200C
PS-120M
MODEL PS-200M**

SECTION 1 SERVICE MANUAL	3
SECTION 2 PARTS LIST	57
SECTION 3 SCHEMATIC DIAGRAM	87

SECTION 1

SERVICE MANUAL

TABLE OF CONTENTS

I. TECHNICAL DATA	4
1. MODEL PS-200C	4
2. MODEL PS-120M	5
3. MODEL PS-200M	5
II. DISMANTLING OF UNIT	6
1. MODEL PS-200C	6
2. MODEL PS-120M (and PS-200M)	7
III. CONTROLS	8
1. MODEL PS-200C	8
2. MODEL PS-120M (and PS-200M)	9
IV. PRINCIPAL PARTS LOCATION	10
1. MODEL PS-200C	10
2. MODEL PS-120M	11
3. MODEL PS-200M	12
V. CIRCUIT OPERATION	13
1. MODEL PS-200C	13
2. MODEL PS-120M (and PS-200M)	15
VI. LEVEL DIAGRAM	21
1. MODEL PS-200C	21
2. MODEL PS-120M (and PS-200M)	21
VII. AMPLIFIER ADJUSTMENT	22
1. MODEL PS-200C	22
2. MODEL PS-120M	23
3. MODEL PS-200M	26
VIII. CLASSIFICATION OF VARIOUS P.C BOARDS	28
1. P.C BOARD TITLES AND IDENTIFICATION NUMBERS	28
2. MODEL PS-200C COMPOSITION OF VARIOUS P.C BOARDS	30
3. MODEL PS-120M COMPOSITION OF VARIOUS P.C BOARDS	36
4. MODEL PS-200M COMPOSITION OF VARIOUS P.C BOARDS	43

For basic adjustments, measuring methods, and operating principles, refer to GENERAL TECHNICAL MANUAL.

I. TECHNICAL DATA

1. MODEL PS-200C

INPUT SENSITIVITY/IMPEDANCE/ SIGNAL TO NOISE RATIO (IHF "A")	
PHONO 1 (MM)	2.5 mV/47 kohms/88 dB
PHONO 2 (MM)	2.5 mV/33, 47, 100 kohms/88 dB
PHONO 3 (MC)	0.07 mV/10 ohms/72 dB
TUNER	150 mV/47 kohms/106 dB
AUX 1/2	150 mV/47 kohms/106 dB
TAPE PLAY 1/2	150 mV/47 kohms/106 dB
OUTPUT LEVEL/IMPEDANCE	
TAPE REC 1/2	150 mV/600 ohms
OUTPUT	1.5V/600 ohms
RATED LOAD IMPEDANCE	1 kohms
PHONO MAX. INPUT LEVEL (1 kHz)	
PHONO 1/2	450 mV
PHONO 3	10 mV
FREQUENCY RESPONSE	
TUNER/AUX 1 & 2/TAPE PLAY 1 & 2	0.8 Hz to 100 kHz ± 1 dB
PHONO 1/2 (RIAA CURVE DEVIATION)	30 Hz to 15 kHz ± 0.2 dB
PHONO 3 (RIAA CURVE DEVIATION)	30 Hz to 15 kHz ± 0.2 dB
TOTAL HARMONIC DISTORTION (20 Hz to 20 kHz)	
TUNER/AUX 1 & 2/TAPE PLAY 1 & 2 (VOLUME MAX.)	0.005% at output 1V 0.002% at output 7V 0.005% at output 15V
PHONO 1/2 (VOLUME MAX.) (VOLUME -20 dB)	0.005% at output 15V 0.005% at output 1.5V
PHONO 3 (VOLUME MAX.) (VOLUME -20 dB)	0.005% at output 15V 0.005% at output 1.5V
TONE CONTROL	
BASS	± 9 dB at 100 Hz
TREBLE	± 9 dB at 10 kHz
SUBSONIC FILTER	12 dB/oct. at 18 Hz
CHANNEL SEPARATION (AUX 1/2)	70 dB (Shorted Circuit)
POWER REQUIREMENTS	
	120V, 60 Hz for U.S.A. and Canada 220V, 50 Hz for Europe except UK 240V, 50 Hz for UK and Australia 110V/220V/240V, 50/60 Hz internally switchable
DIMENSIONS	440(W) x 90(H) x 457(D)
WEIGHT	7.5 kg

2. MODEL PS-120M

RATED POWER OUTPUT	130 watts per channel, min. RMS, at 8 ohms from 20 Hz to 20 kHz with no more than 0.008% THD.
TOTAL HARMONIC DISTORTION	0.008% at rated power output
INTERMODULATION DISTORTION	0.008% at rated power output
SIGNAL TO NOISE RATIO (IHF "A")	115 dB
RESIDUAL NOISE (IHF "A"/8 OHMS)	0.2 mV
INPUT SENSITIVITY/IMPEDANCE	1V/47 kohms
DAMPING FACTOR (IHF)	350
REQUIRED LOAD IMPEDANCE	4 ohms to 16 ohms
FREQUENCY RESPONSE	DC to 100 kHz ± 0.5 dB
SUBSONIC FILTER	12 dB/oct. at 18 Hz
POWER REQUIREMENTS	
	120V, 60 Hz for U.S.A. and Canada 220V, 50 Hz for Europe except UK 240V, 50 Hz for UK and Australia 110/220/240V, 50/60 Hz internally switchable
DIMENSIONS	44(W) x 198(H) x 459(D) mm
WEIGHT	30 kg

3. MODEL PS-200M

RATED POWER OUTPUT	220 watts per channel, min. RMS, at 8 ohms from 20 Hz to 20 kHz with no more than 0.008% THD.
TOTAL HARMONIC DISTORTION	0.008% at rated power output
INTERMODULATION DISTORTION	0.008% at rated power output
SIGNAL TO NOISE RATIO (IHF "A")	115 dB
RESIDUAL NOISE (IHF "A"/8 OHMS)	0.2 mV
INPUT SENSITIVITY/IMPEDANCE	1V/47 mV
DAMPING FACTOR (IHF)	350
REQUIRED LOAD IMPEDANCE	4 ohms to 16 ohms
FREQUENCY RESPONSE	DC to 100 kHz ± 0.2 dB
SUBSONIC FILTER	12 dB/oct. at 18 Hz
POWER REQUIREMENTS	
	120V, 60 Hz for U.S.A. and Canada 220V, 50 Hz for Europe except UK 240V, 50 Hz for UK and Australia 110/220/240V, 50/60 Hz internally switchable for other countries.
DIMENSIONS	440(W) x 198(H) x 459(D) mm
WEIGHT	30 kg

* For improvement purposes, specifications and design are subject to change without notice.

II. DISMANTLING OF UNIT

1. MODEL PS-200C

In case of trouble, etc. necessitating dismantling, please dismantle in the order shown in the photographs. Reassemble in reverse order.

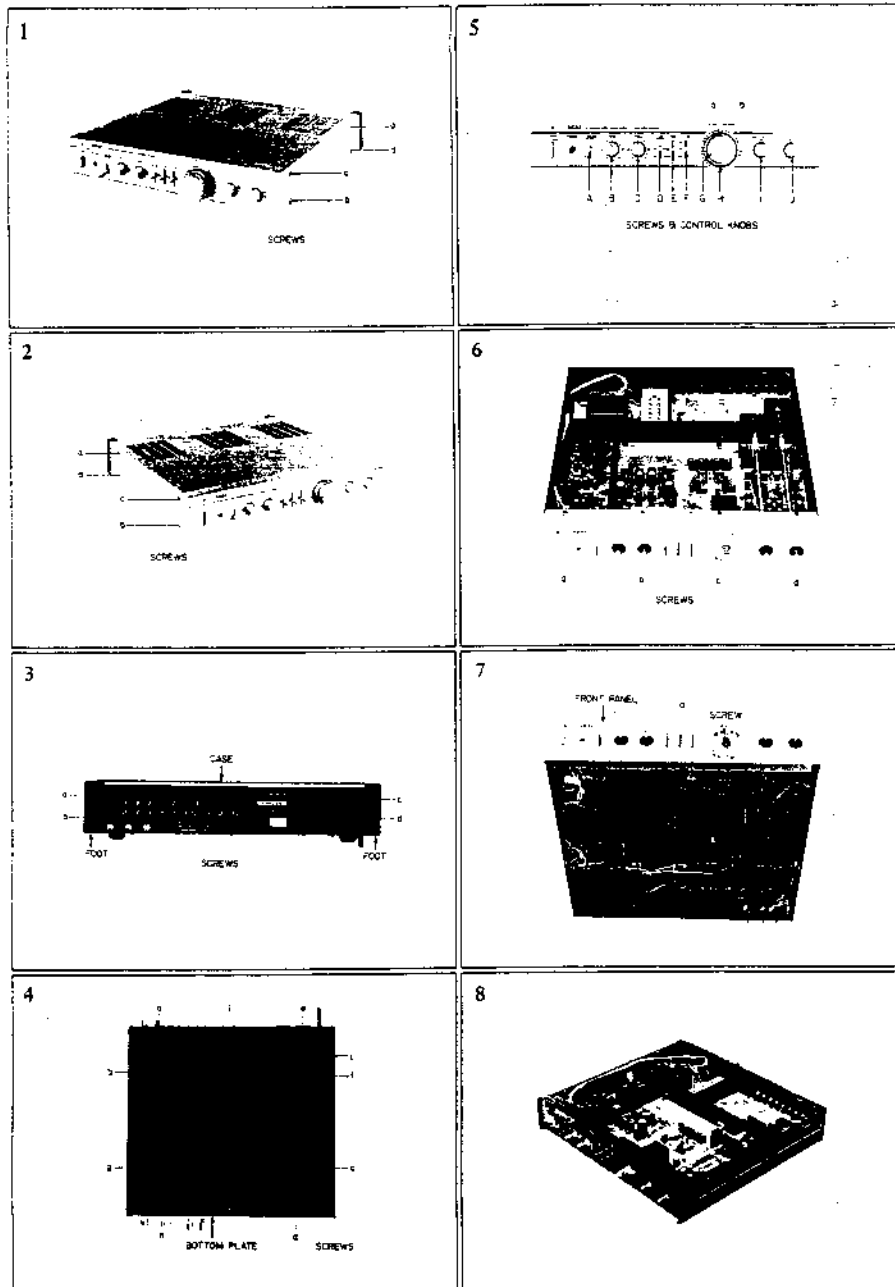

2. MODEL PS-120M (and PS-200M)

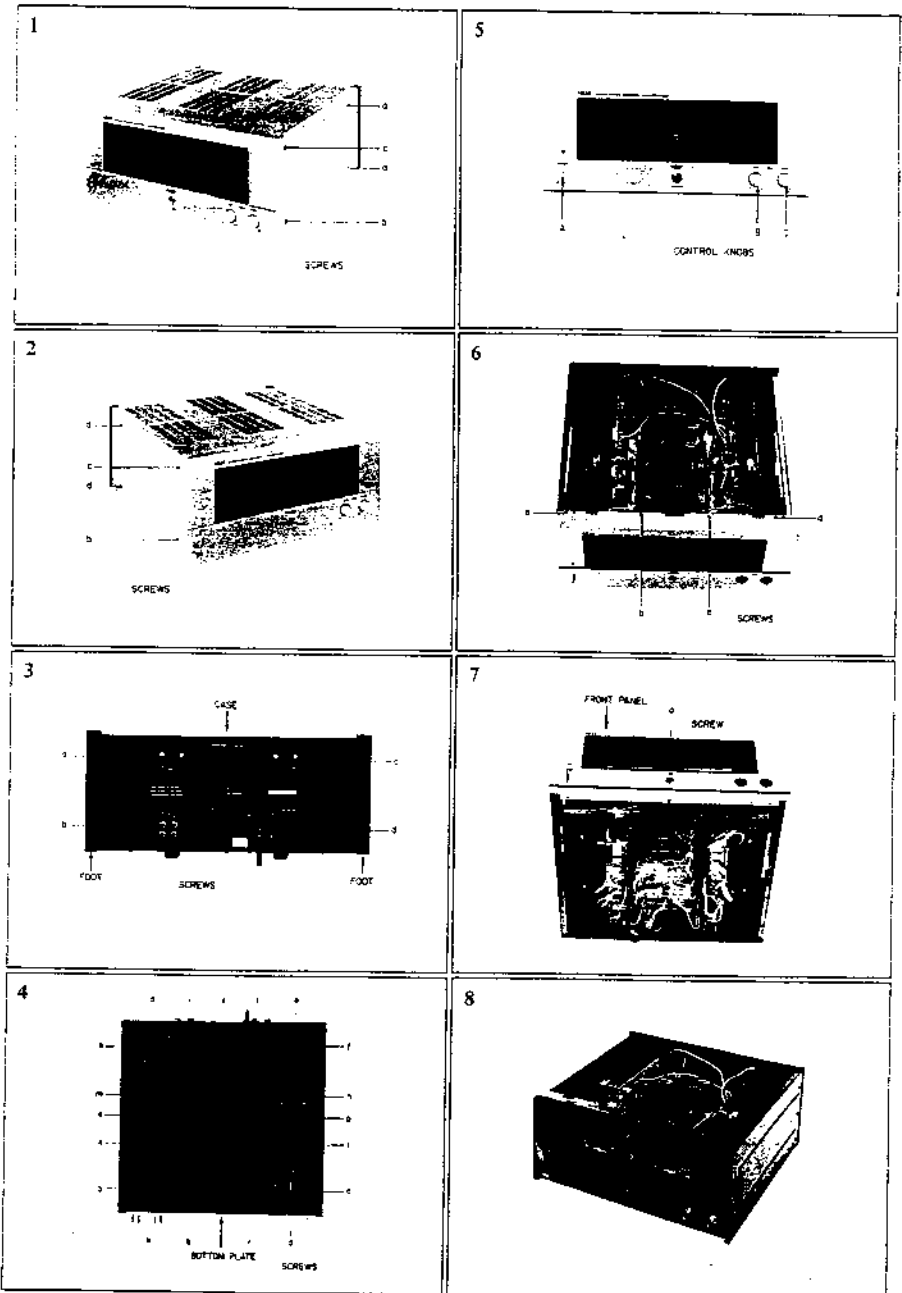

III. CONTROLS

1. MODEL PS-200C

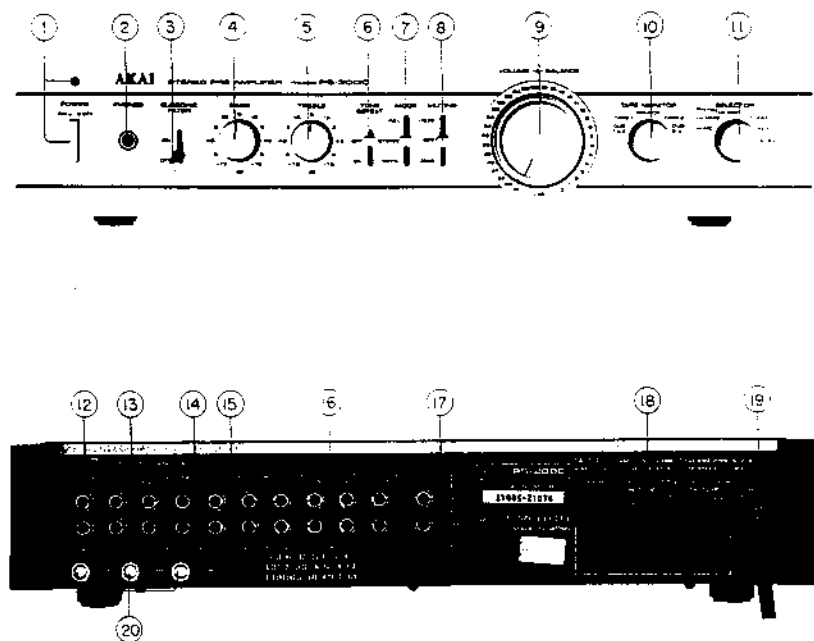

Fig. 1 Controls (PS-200C)

- | | |
|--------------------------------|--|
| 1. POWER SWITCH AND INDICATOR | 11. INPUT SELECTOR |
| 2. HEADPHONE JACK | 12. CARTRIDGE IMPEDANCE SWITCH (MM2 Only) |
| 3. SUBSONIC FILTER | 13. PHONO TERMINALS |
| 4. BASS TONE CONTROL | 14. TUNER TERMINALS |
| 5. TREBLE TONE CONTROL | 15. AUX TERMINALS (2 set supplied) |
| 6. TONE SWITCH | 16. TAPE 1 AND TAPE 2 SYSTEM REC/P.B TERMINALS |
| 7. MODE SWITCH | 17. OUTPUT |
| 8. MUTING SWITCH | 18. EXTRA AC OUTLETS (Some models are not equipped with this facility) |
| 9. VOLUME AND BALANCE CONTROLS | 19. AC POWER CORD (Some models equipped with AC inlet) |
| 10. TAPE MONITOR SWITCH | 20. GROUND TERMINALS FOR PHONO |

2. MODEL PS-120M (and PS-200M)

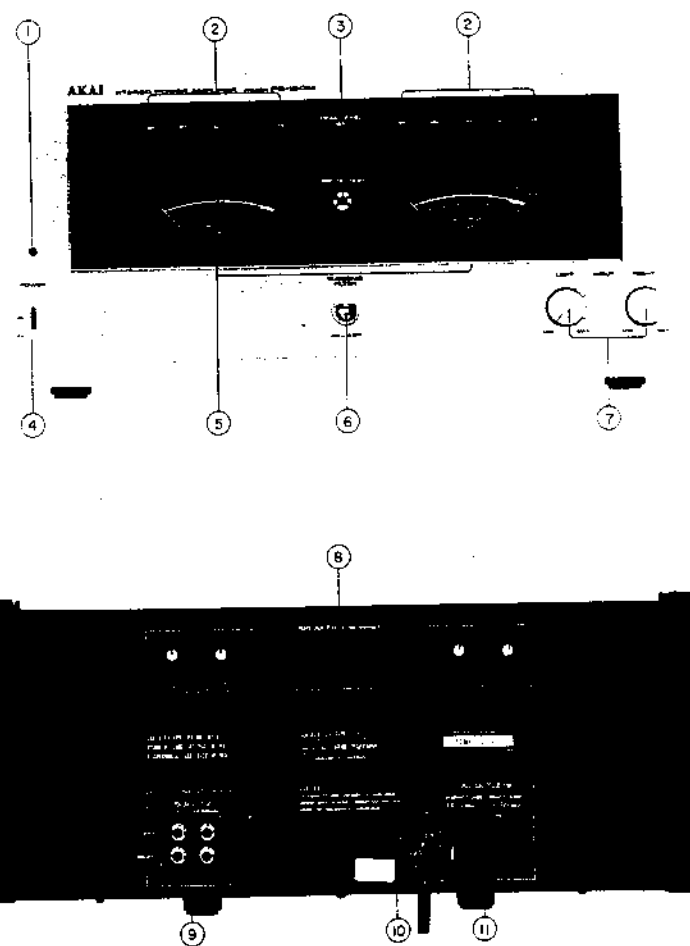

Fig. 2 Controls (PS-120M)

- | | |
|---|---|
| 1. POWER INDICATOR | 8. SPEAKER SYSTEM TERMINALS |
| 2. PEAK LEVEL LEDS (Light Emitting Diodes) | 9. INPUT JACKS |
| 3. PROTECTION INDICATOR | 10. POWER CORD
(Some models have power cord inlets instead) |
| 4. POWER SWITCH | 11. AC OUTLETS
(Some models are not equipped with this facility) |
| 5. LEFT AND RIGHT CHANNEL PEAK LEVEL METERS | |
| 6. SUBSONIC FILTER | |
| 7. LEFT AND RIGHT INPUT LEVEL CONTROLS | |

IV. PRINCIPAL PARTS LOCATION

1. MODEL PS-200C

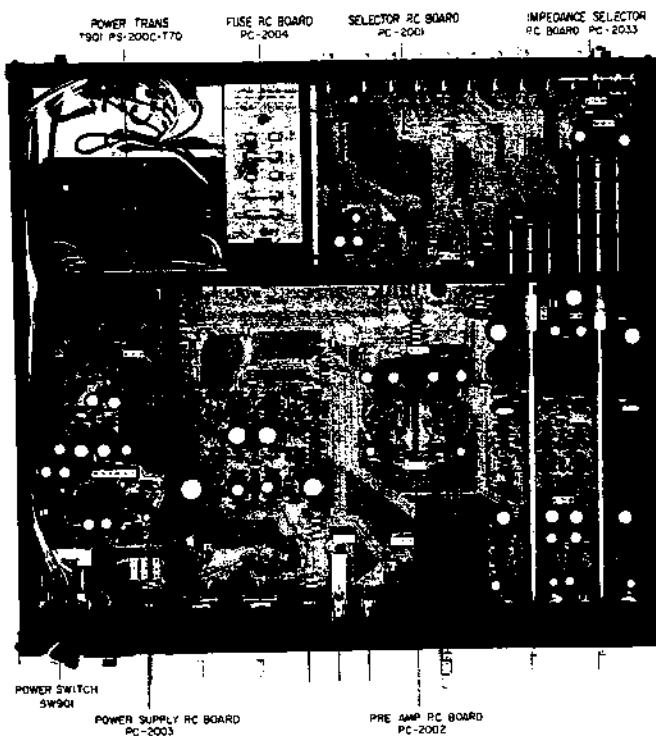

Fig. 3 Top View

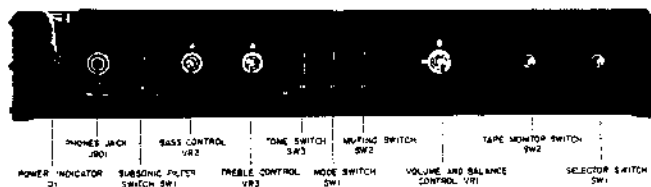

Fig. 4 Front View

2. MODEL PS-120M

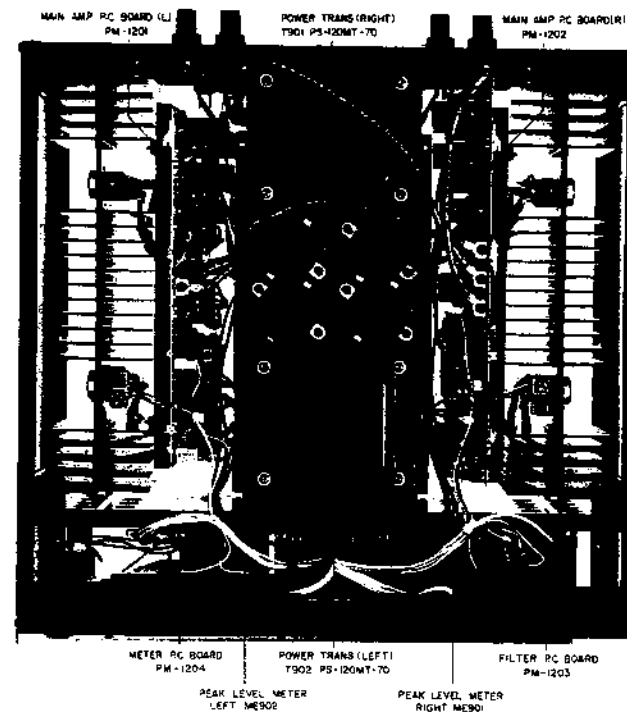

Fig. 5 Top View

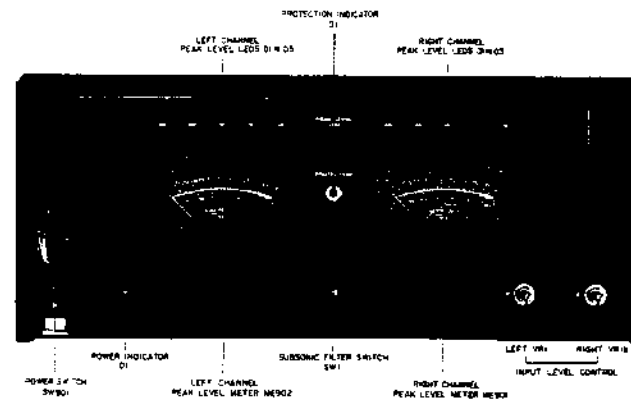

Fig. 6 Front View

3. MODEL PS-200M

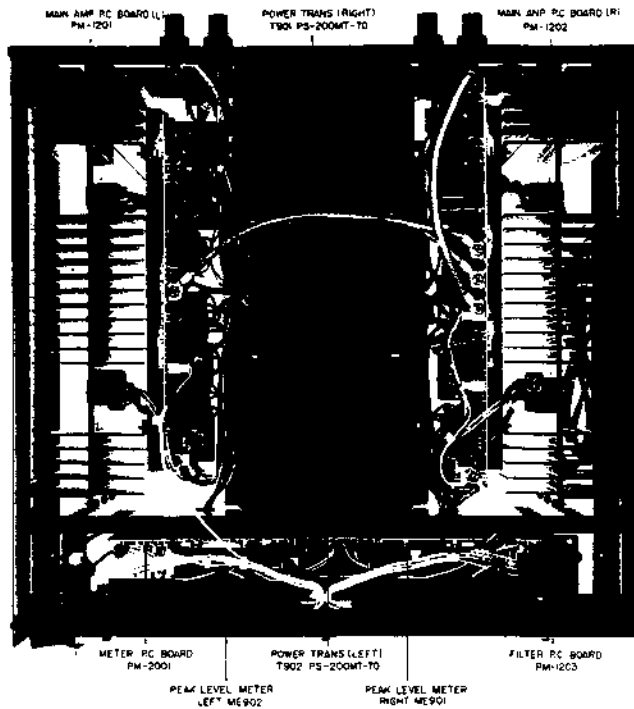

Fig. 7 Top View

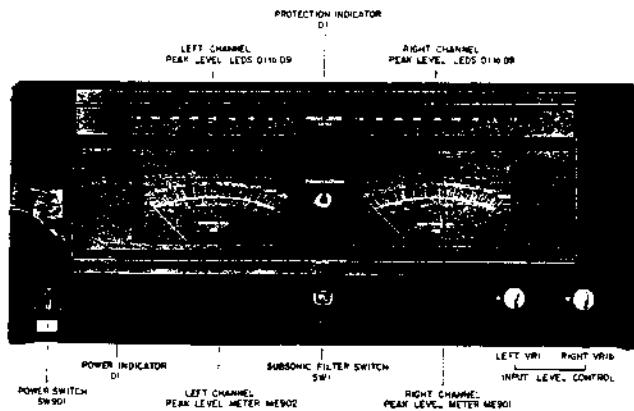

Fig. 8 Front View

V. CIRCUIT OPERATION

1. MODEL PS-200C

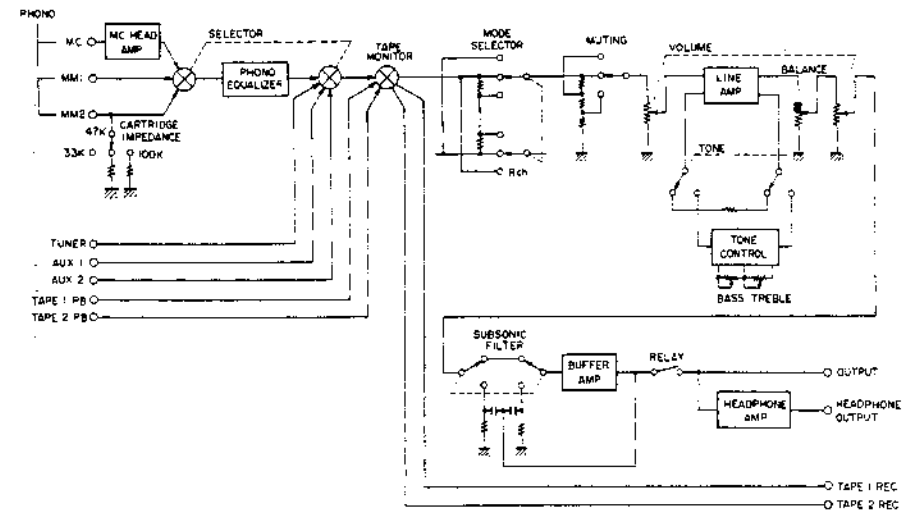

Fig. 9 Block Diagram (L Channel Only)

1) MC Head Amp

MC PHONO input's reference input is a low 0.07 mV. Therefore, a gain of approximately 30 dB at 1 kHz is obtained from the Head Amp to make the Equalizer Amp input equal to the MM type input. The circuit is made up of high h_{fe} , low noise transistors connected in parallel to obtain high gain in the first stage. The pure complimentary push-pull last stage uses transistors with good linearity. The dynamic range of the Head Amp deserves attention. The Head Amp is a flat amp with no RIAA characteristics, unlike the Equalizer Amp. The output of the cartridge increases with frequency with 1 kHz as reference. For this reason, even if sufficient dynamic range is obtained in the low and mid frequencies, there may be clipping in the high frequency. It is therefore necessary that the Head Amp does not saturate at the level at least where clipping occurs in the Equalizer Amp. The maximum allowable input voltage of this model is 10 mV at 1 kHz.

2) Equalizer Amp

The circuit is composed of a differential amplifier with cascade connected low noise one-chip dual FET in the first stage. Also, by using a constant current power source as a common source, CMRR (Common Mode Rejection Ratio) is improved. Distortion is also circumscribed by the differential amplifier in the next stage. The last stage is a Darlington connected pure complimentary push-pull circuit. The NFB type equalizer features a stable frequency response and receives very little influence from heat, etc. By using a high precision part for the equalizer element, RIAA deviation is held within ± 0.2 dB from the standard value with frequency response range of 30~15 kHz for this model. The circuit operation of the differential amplifier in the first stage is described below. The circuit is shown in Fig. 10. TR1a is connected in series to TR2 and TR1b is connected in series to TR3. Also a constant voltage is applied to the common gate of TR2 and TR3 from the resistance

2. MODEL PS-120M and PS-200M

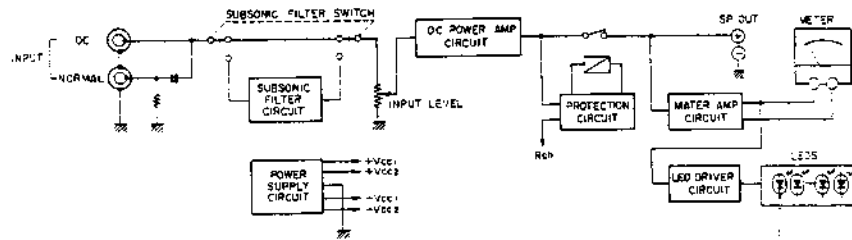

Fig. 11 Block Diagram

1) Input Circuit

These models are equipped with two terminals, DC and NORMAL, for input. By using the "DC" input, they become DC amplifiers without input coupling condenser. By using the "NORMAL" input, the coupling condenser cuts off the DC part. Also when the Subsonic Filter Switch is turned ON, the low range of 18 Hz or less is reduced by 12 dB/oct.

2) DC Power Amplifier Circuit

The signal from the input circuit passes the Input Level Control and enters the DC amplifier system's Power Amplifier Input. To explain what is meant by the DC amplifier system: Condensers are used in circuits to obtain certain characteristics for DC operation, AC gain, and impedance when making an amplifier. However, condenser reactance increases in reverse proportion to the signal frequency and ultra low signals cannot be handled in AC. In circuit using many condensers, condenser reactance can be thought of as 0 in the midrange signals but in the ultra low range, condenser

reactance is thought of as unlimited. When the midrange and the ultra low range equivalent circuits are compared; the gain, input and output impedances at each stage, and distortion, etc., changes widely.

In DC amplifiers, the condensers in the circuits, as above, are all removed. The same amplitude and impedance, etc., can be obtained in DC or AC in this design. In addition, the first stage differential transistor, FET pairing, and temperature balance, etc., becomes absolute necessity in the DC amplifiers. Next, although circuit-constructed, cascade connected differential amplifier used in PS-200C is used for the first stage. The voltage gain is obtained from the transistor differential amplifier in the next stage, and the input to the next stage is obtained from each collector.

The signals from the TR10 and TR11 collectors pass the pure complimentary push-pull TR19 and 20 and TR21 and 22, respectively. They are current amplified by the parallel push-pull power transistors and connected to SP OUT.

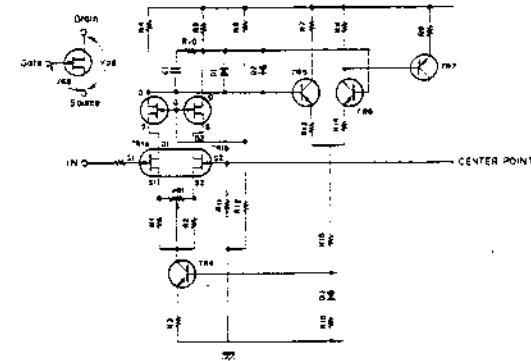

Fig. 10 Input Circuit of The Differential Amplifier

split of R6 and R12 regardless of the input signal.

The circuit is cascade connected in this way and a one-chip dual FET is used for TR1.

These circuits have advantages such as DC drift decrease, current noise decrease and improvement in frequency response characteristics.

Then the gate potential of TR1a increases, the impedance between TR1a drain and source decreases, and the drain current increases. Since TR1 is made up of dual FET differential amplifier, TR1b drain current decreases proportionately to TR1a drain current increase. This causes TR1a drain potential to decrease and TR1b drain potential to increase. Since TR2 and TR3 gate potentials are constant, TR2 and TR3 VGS vary due to changes in TR1a and TR1b drain potentials. TR2 drain current increases and TR3 drain current decreases due to this variance.

When the gate potential of TR1a decreases, the impedance between TR1a drain and source increases and the drain current decreases. TR1b drain current thereby increases proportionately to TR1a decrease. TR1a drain potential increases and TR1b drain potential decreases as a result. On the other hand TR2 VGS decreases and TR3 VGS increases to increase the TR2 drain potential by TR2 drain current decrease and to decrease the TR3 drain potential by the TR3 drain current increase.

In other words, TR1a gate signal input appears in reverse phase, equal voltage signal at R4 and R5 load resistors. This signal enters between the TR5 and TR6 bases as differential amplifier inputs of those two. By this, the output between the two drains in the first stage becomes a push-pull operation, and the distortion is minimized.

Since the circuit structure is two differential amplifiers used together, total CMRR is a product of the first stage CMRR and the second stage CMRR.

Even if there is an increase in the drain current, or an in-phase input due to noise, etc., any collector potential change is held down to result in a stable center potential and a decreased DC drift.

The output from the second stage differential amplifier is an unbalanced type taken out only from the TR6 collector. It is phase inverted in the next stage and pulls out the equalizer amplifier output signal as a push-pull circuit.

3) Line Amplifier

This circuit is almost exactly the same circuit-constructed flat amplifier as the equalizer amplifier without the NFB equalizer circuit. By equipping interlocking volumes on the input and the output sides, S/N ratio is improved when the volume is turned low.

4) Output Circuit

The output from the line amplifier passes the balance control, volume control, subsonic filter switch and is supplied to the buffer amplifier.

The buffer amplifier is an impedance conversion circuit used to prevent crossing between the circuit. Consequently, it requires high input impedance, low output impedance, no distortion, wide dynamic range, flat frequency response characteristics and low noise, etc. These are fulfilled in this model by using the pure complimentary SEPP type emitter follower circuit.

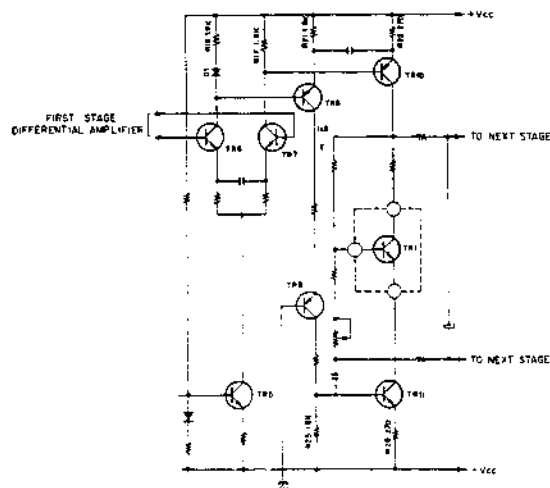

Fig. 12 Pre Driver Circuit

3) Pre Driver Circuit (Refer to Fig. 12)

The negative phase signals from the first stage differential amplifier (refer to PS-200C circuit explanation) enter the bases of TR6 and TR7 and the negative phase outputs from each collector become base inputs to the transistors of the next stage. Although the signal from the TR7 collector becomes the base input of TR10, the signal from the TR6 collector must become TR11 base input to have the push-pull circuitry. Voltage between two sides of R17 (1.8 k) is supplied to TR10 base bias. TR8 is biased by voltage between two sides of R16 (1.8 k) + D1 and is supplied with IC8. And since V_{BE} of TR8

is approximately the same voltage as the D1 voltage drop, R21 (1.8 k) is supplied with the same voltage as the voltage between two sides of R16 = R17 (1.8 k). This IC8 passes the cascade connected TR9 and flows to R25 (1.8 k). Since R21 and R25 resistor values are equal, TR11 base is supplied with an equal potential bias as the TR10 base. As explained above, TR7 collector signal enters the TR10 base, TR6 collector signal appears in the voltage between two sides of R25 as a change in IC8 and enters TR11 base after which it is passed to the next stage by the push-pull circuitry.

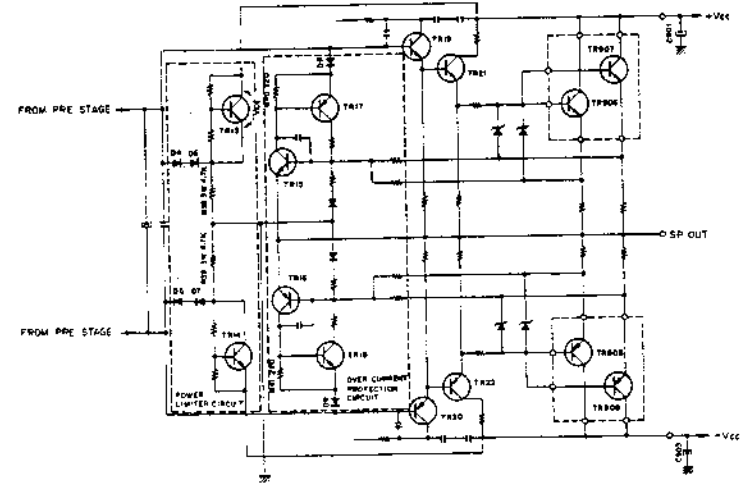

Fig. 13

4) Over Current Protection Circuit (Refer to Fig. 13)

When the speaker terminal of the power amplifier is shortcircuited or when the load impedance equivalently becomes too low due to too many speaker connections, the output stage transistor breaks down because of excessive power consumption by the transistors or of excess current. The circuit shown in Fig. 13 composed of TR15 and 17 and TR16 and 18 prevents this damage. TR15 and 17 circuit operates for excessive + signal current and TR16 and 18 operate for excessive - signal. The case when there is a current overflow of + signal will be explained here. Ordinarily, TR15 base potential and the emitter potential are almost equal and TR15 is OFF. When the load R_L becomes lower than the power amplifier's specified load or is short-circuited, excess current flows to the output stage transistor. This causes the base potential of TR15 to become greater than the emitter potential and TR15 turns ON. When this happens, the signal to TR19 passes D8 and R40 and is dropped to the center (node) point. The output stage transistor, therefore, stops receiving the signal and the excess current does not flow. Also when TR15 is turned ON, TR17 base potential is decreased to turn on TR17. TR15 base potential is thereby further increased to make the operation fullproof. Also when TR15 is turned ON, relay RL1 (see Fig. 14) turns OFF and the power amplifier output is disconnected from the speaker. TR16 and 18 operate in the same way for excess signal current to protect the output stage transistor.

5) Power Limiter Circuit (Refer to Fig. 13)

This circuit is to protect the output stage transistor at excessive input. When the input signal voltage to TR19 and TR20 exceeds a certain point, it is limited and prevents excessive input to the output stage transistor. Only the case of positive signal input will be explained here. There is very little voltage amplification because TR19, TR21, and the output stage transistor are emitter followers at current amplification. In other words, the TR19 base is supplied with the same voltage as speaker output voltage. So the maximum voltage to appear at the output is $+V_{CC}$. Signals with voltage of no less than approximately 2.1V or 3 diode voltage drops less than this $+V_{CC}$ are limited by TR13, D4, and D6. To explain the circuit operation, first, $+V_{CC}$ is added to the TR13 collector. The voltage between TR13 collector and emitter has a potential of 5 diode voltage drops or approximately 3.5V according to the design, and a voltage 3.5V lower than C901 positive voltage appears at the emitter. Next, taking a look at the signal voltage, we find that when the value after subtracting the voltage drops of D4 and D6 (approximately $0.7V \times 2$) is greater than TR13 emitter potential, the signal passes R38 and is grounded to be limited. By the above operation, when there is a voltage no less than the value approximately 2.1V (Voltage drops of D4 and D6 subtracted from TR13 V_{CE}) less than $+V_{CC}$, the signal passes D4→D6→R38 and is grounded to limit the output.

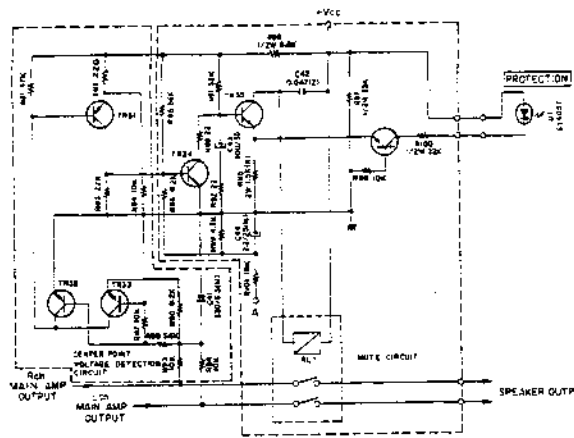

Fig. 14

6) Mute Circuit (Refer to Fig. 14)

When the power of the amplifier is turned on or off, pop and distortion noise generate to damage the speakers or produce unpleasant sound. The mute circuit of Fig. 14 prevents these.

When the power is ON, point A is supplied with a diode rectified negative pulse current and charges C44 through R101. While C44 is being charged, TR34 base is supplied with the potential from +V_{CC} and turns ON. On the otherhand, TR35 base potential decreases to turn OFF. At this condition since TR35 collector current does not flow to R95, TR36 base potential becomes higher than the emitter potential and TR36 is turned ON. When TR36 is turned ON, collector current flows through R100 and R95 and the PROTECTION INDICATOR D1 illuminates. When C44 is finished being charged, TR34 turns off. Then the base current of TR35 turns on TR35 after charging the time constant circuit. Relay RL1 is driven by the TR35 collector current and the main amplifier output is connected to the speaker output. In this conditions, TR36 emitter potential becomes higher than the base potential so that TR36 turns OFF and the Protection Indicator D1 lights off.

When the power is OFF, point A is not supplied with the pulse current.

The C44 charge, therefore, discharges through R99 and raises the base potential of TR34 to turn ON TR34. TR35 base potential then decreases to turn OFF TR35 and the relay RL1 also turns off. When the TR35 collector current stops flowing, TR36 base potential becomes higher than the emitter potential and turns ON to light the PROTECTION INDICATOR D1. However, since the potential of +V_{CC} gradually decreases, TR36 base potential decreases to

turn OFF and the PROTECTION INDICATOR D1 also turns off.

7) Center (node) Point Voltage Detection Circuit (Refer to Fig. 14)

When there is DC potential at the power amplifier's speaker output terminal, the DC will flow to the speaker in the case of OCL circuitry and damage the speakers. For this reason, when there is a DC potential, a circuit is necessary to detect the potential to turn off the mute circuit relay RL1 and cut off the speaker from the power amplifier output. This circuit is called a center (node) point voltage detection circuit and is shown in Fig. 14.

Ordinarily the center (node) point is 0V and TR32 and 33 are OFF. C41 is a non-pole condenser and is grounded that there is no effect from the AC signal. But when there is a positive DC potential at the center point, that potential positively charges C41 on the side opposite to the ground. Consequently, TR32 is base biased and is turned ON, TR31 base becomes ground potential and TR31 turns ON. When TR31 turns ON, TR34 base potential is increased, TR34 turns ON, and TR35 base potential decreases. When TR35 is turned OFF, relay RL1 turns OFF and the power amplifier output is disconnected from the speakers.

Next, if there is a negative DC potential at the center point, that potential negatively charges C41 on the opposite side to the ground and TR33 emitter potential becomes lower than the base potential to turn ON TR33. Accordingly, TR31 base becomes ground potential and relay RL1 turns off as mentioned earlier and the power amplifier is cut off from the speaker.

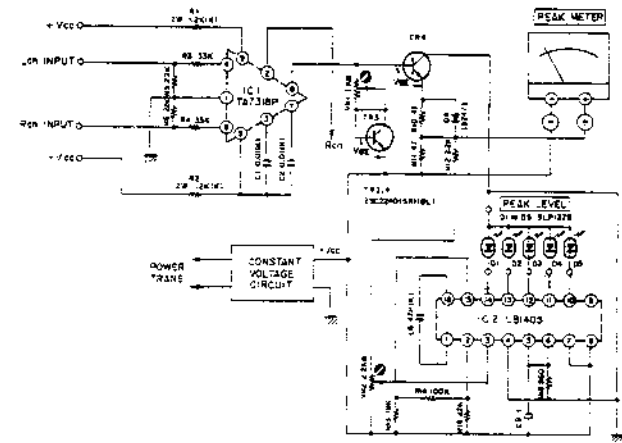

Fig. 15 Meter Amplifier and LED Drive Circuit

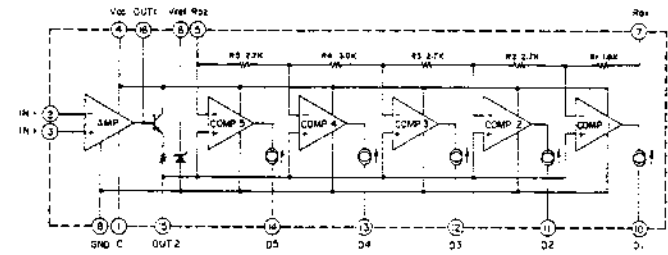

Fig. 16 LB1405 Block Diagram

8) Meter Amplifier and LED Drive Circuit

(Refer to Fig. 15, 16)

The signal from the speaker output enters the input of Meter Amplifier IC1 and comes out of terminals 2 and 8 as output. The peak meter used in these models requires approximately 40 mA of electric current. Since the output current from IC1 is not enough, the output from IC1 is current amplified by the TR4 emitter follower circuit to drive the meter. Also because of the large current, constant voltage circuit, TR1 and TR2, supplies the current. TR3 equalizes TR4 V_{BE} and TR3 V_{BE} and equalizes V_{BE} changes due to base current changes for good

linearity to the meter input.

D4 assists in obtaining good linearity of the meter itself. When the signal voltage increases to a certain point, D4 provides continuity to increase the meter drive current and compensates the linearity.

IC LB1405 is used for the LED drive. Fig. 16 shows the block diagram. The signal entering terminal 3 is amplified and is passed to each comparator. A resistance divided constant voltage for each level is supplied to one side of the comparators. The IC compares each input signal with this constant voltage and detects it to drive the LED of each level.

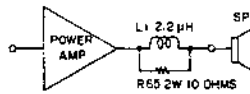

Fig. 17

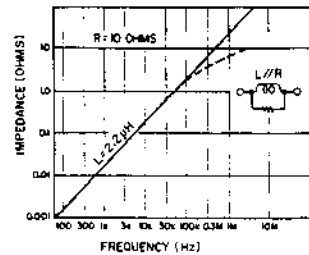

Fig. 18

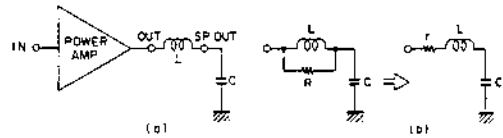

Fig. 19

9) LI and R65 Operation (Refer to Fig. 17 to 19)

As shown in Fig. 17, most amplifiers have an inductance or a resistor between the output and the speaker. The inclusion has several advantages.

Considering the negative effect when L and R is inputted, we find that the power amplifier output impedance increases higher the frequency in the case of inductance. This negative effect is shown in Fig. 18. However, as can be seen in the figure, the effect of the inductance is merely 0.014 ohm at 1 kHz and 1.4 ohm even at 100 kHz, and is hardly a problem.

Considering the positive side, we find that the impedance seen from the load terminal becomes extremely low at high frequencies due to such factors as speaker cord capacitive components and L-C networks for speaker frequency divider. However,

the load impedance seen from the power amplifier output can maintain a value above a certain level due to the effect from L and R added in series to the load terminal.

Also the addition of L and R serves as a buffer when the power amplifier begins high range oscillation as a result of poor grounding of the Pin jack or phase difference caused by capacitance load at the output stage, etc. When something with a capacitance component is connected to the load in this way, a series resonance circuit is constructed as in Fig. 19(a) and the load impedance becomes 0 at the resonance point. But because of the operation of R connected parallel to L, the resonance circuit is damped and looks as if a pure resistor has been added equivalently as in Fig. 19(b), and the load impedance does not become zero even at the resonance point.

VI. LEVEL DIAGRAM

1. MODEL PS-200C

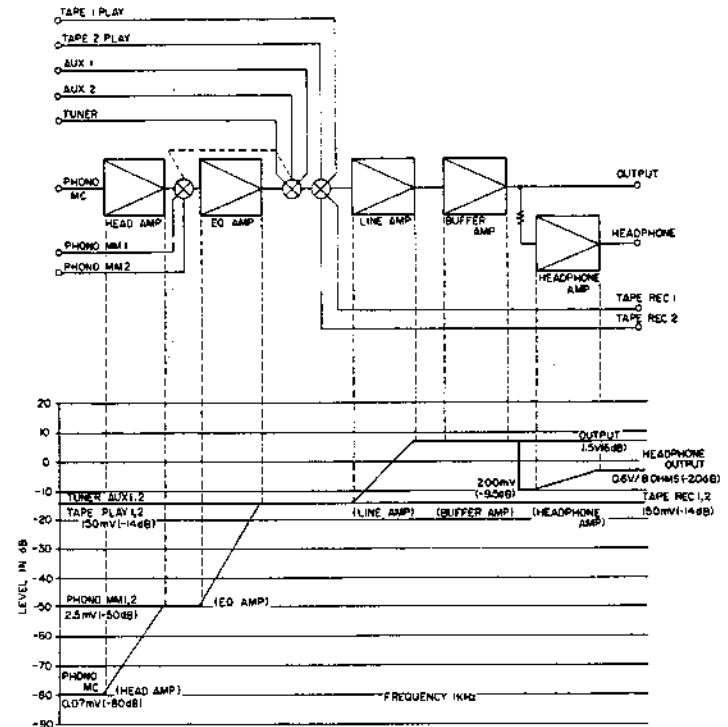

Fig. 20 Level Diagram PS-200M

2. MODEL PS-120M and PS-200M

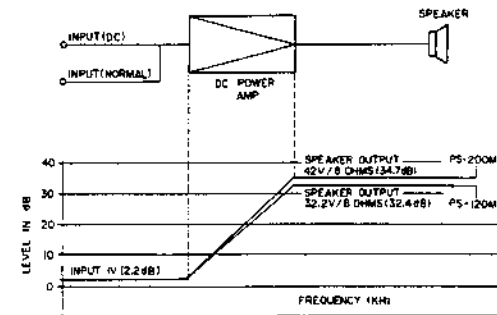

Fig. 21 Level Diagram PS-120M and PS-200M

VII. AMPLIFIER ADJUSTMENT

1. MODEL PS-200C (Refer to Fig. 22)

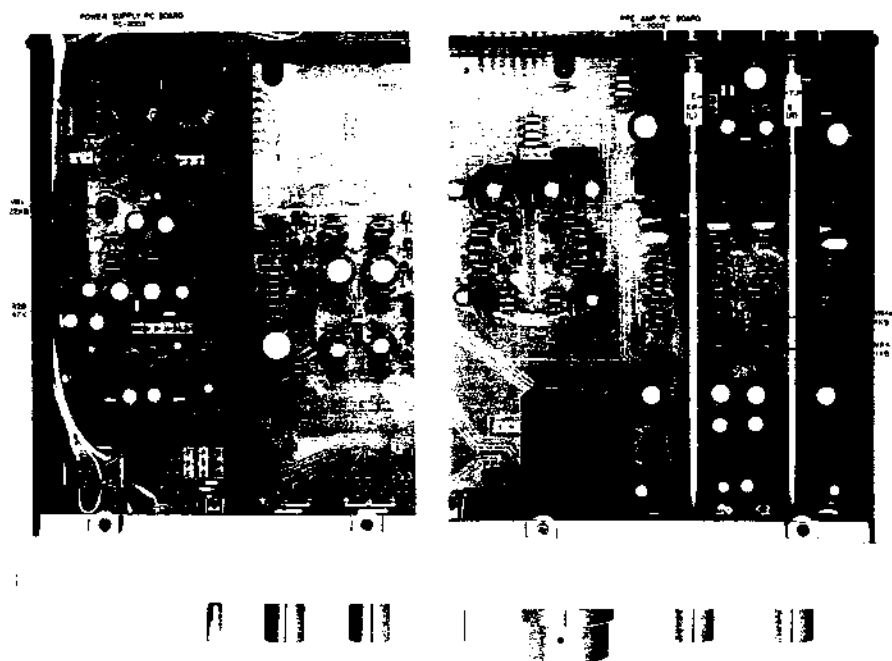

Fig. 22 Adjustment Point

Step	Adjustment Item	Measuring Instrument Connection	Adjustment Point	Result	Remarks
1	DC Power Supply Voltage Adjustment	DC Voltmeter or Digital Voltmeter between R28 ⊕ and Ground	VR1 22 kΩ (Power Supply P.C Board)	42.0 V	
2	L ch Center Off-set Voltage Adjustment	DC Voltmeter or Digital Voltmeter between T.P (L) and Ground	VR4 1 kΩ (Pre Amp P.C Board)	0 ± 0.5 V	OK if 0 ± 0.5 V at the beginning of adjustment
3	R ch Center Off-set Voltage Adjustment	DC Voltmeter or Digital Voltmeter between T.P (R) and Ground	VR4b 1 kΩ (Pre Amp P.C Board)	0 ± 0.5 V	

Chart-1

2. MODEL PS-120M (Refer to Figs. 23, 24)

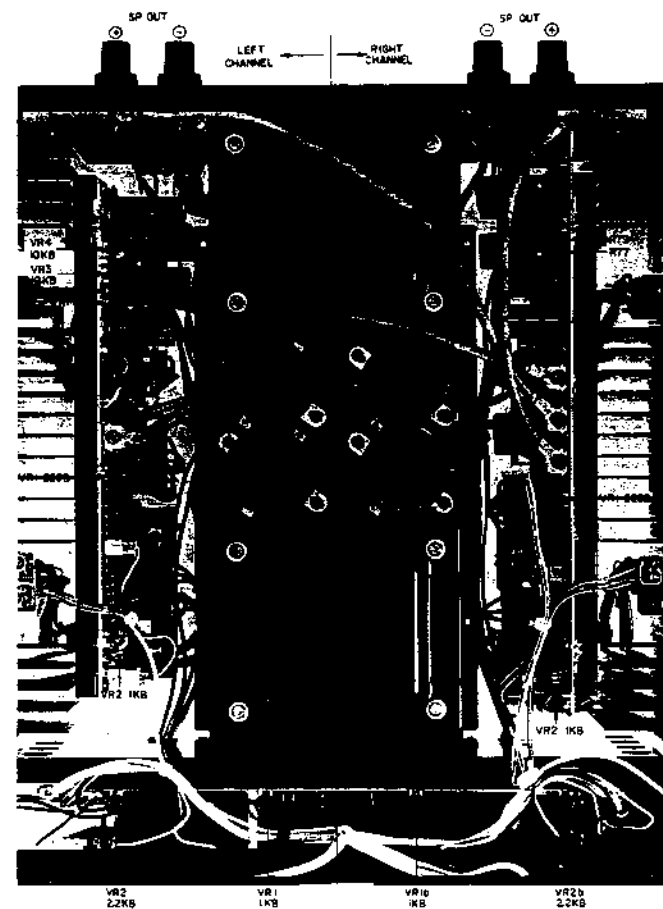

Fig. 23 Adjustment Point

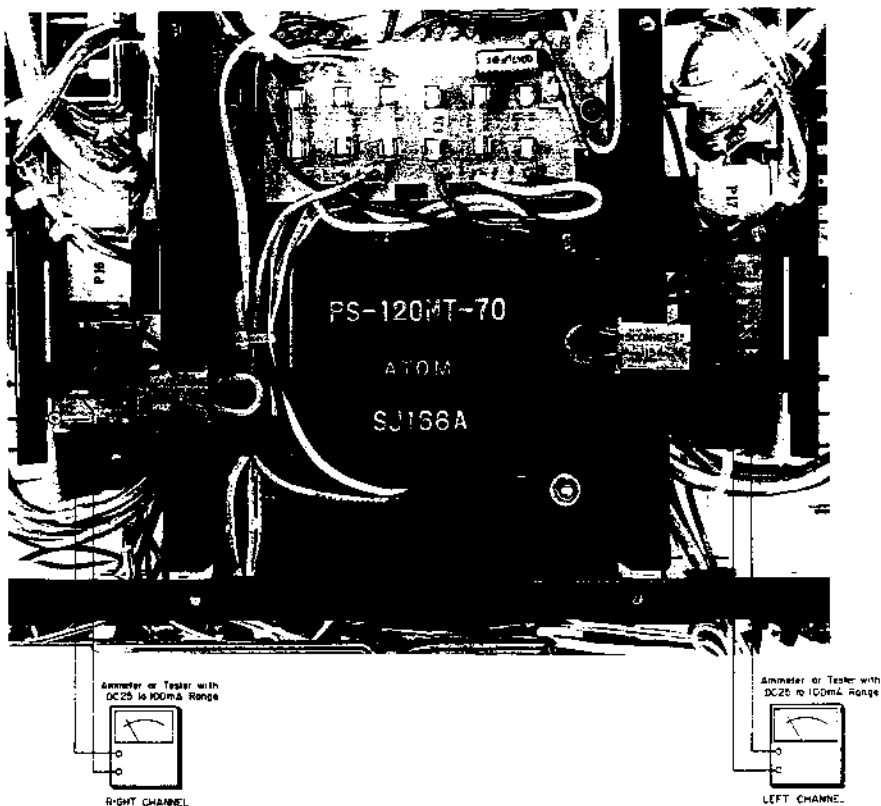

Fig. 24 Idling Current Adjustment

Step	Adjustment Item	Measuring Instrument Connection	Adjustment Point	Result	Remarks
1	L ch -DC Power Supply Voltage Adjustment	DC Voltmeter or Digital Voltmeter between R79 and Ground	VR4 10 kB (Main Amp P.C Board (L))	-62.0 V	Refer to NOTE 2.
2	L ch +DC Power Supply Voltage Adjustment	DC Voltmeter or Digital Voltmeter between R77 and Ground	VR3 10 kB (Main Amp P.C Board (L))	+62.0 V	Refer to NOTE 2.
3	L ch Center Off-set Voltage Adjustment	DC Voltmeter or Digital Voltmeter between L ch SP OUT ⊕ and ⊖	VR1 220 B (Main Amp P.C Board (L))	0 ± 0.5 V	OK if 0 ± 0.5 mV at the beginning of adjustment
4	L ch Idling Current Adjustment	DC Ammeter or Tester between P15 ⊕ and ⊖	VR2 1 kB (Main Amp P.C Board (L))	20 mA	Refer to Fig. 7 and NOTE 3.
5	R ch -DC Power Supply Voltage Adjustment	DC Voltmeter or Digital Voltmeter between R79 and Ground	VR4 10 kB (Main Amp P.C Board (R))	-62.0 V	Refer to NOTE 2.
6	R ch +DC Power Supply Voltage Adjustment	DC Voltmeter or Digital Voltmeter between R77 and Ground	VR3 10 kB (Main Amp P.C Board (R))	+62.0 V	Refer to NOTE 2.
7	R ch Center Off-set Voltage Adjustment	DC Voltmeter or Digital Voltmeter between R ch SP OUT ⊕ and ⊖	VR1 220 B (Main Amp P.C Board (R))	0 ± 0.5 mV	OK if 0 ± 0.5 mV at the beginning of adjustment
8	R ch Idling Current Adjustment	DC Ammeter or Tester between P14 ⊕ and ⊖	VR2 1 kB (Main Amp P.C Board (R))	20 mA	Refer to Fig. 7 and NOTE 3.
9	L ch Meter Sensitivity Adjustment	AC Voltmeter between L ch SP OUT ⊕ and ⊖	VR1 1 kB (Meter P.C Board)	Meter indicates 120 W	Input 1 kHz sine wave & adjust the input level until the AC Voltmeter reads 31.0 V. Refer to NOTE 4.
10	L ch LED Sensitivity Adjustment	AC Voltmeter between L ch SP OUT ⊕ and ⊖	VR2 2.2 kB (Meter P.C Board)		Input 1 kHz sine wave, control the output level with the input level, and adjust VR2 so that 0 dB LED will go on at SP output of 31.0V (120W) and off at 28.3V (100W). Refer to NOTE 4.
11	R ch Meter Sensitivity Adjustment	AC Voltmeter between R ch SP OUT ⊕ and ⊖	VR1b 1 kB (Meter P.C Board)	Meter indicates 120 W	Input 1 kHz sine wave & adjust the input level until the AC Voltmeter reads 31.0 V. Refer to NOTE 4.
12	R ch LED Sensitivity Adjustment	AC Voltmeter between R ch SP OUT ⊕ and ⊖	VR1b 2.2 kB (Meter P.C Board)		Input 1 kHz sine wave, control the output level with the input level, and adjust VR2 so that 0 dB LED will go on at SP output of 31.0V (120W) and off at 28.3V (100W). Refer to NOTE 4.

Chart-2

- NOTES:**
1. Connect and disconnect a measuring equipment only after the power has turned off for several seconds.
 2. When connecting the Voltmeter for Steps 1, 2, 5 and 6, do not shortcircuit positive and negative power sources.
 3. When connecting the DC Ammeter for Steps 4 and 8, do not touch the angle fixing the P.C Board.
 4. Do adjustments in steps 9 to 12 with the input in only one channel.

3. MODEL PS-200M (Refer to Figs. 23, 24)

Step	Adjustment Item	Measuring Instrument Connection	Adjustment Point	Result	Remarks
1	L ch -DC Power Supply Voltage Adjustment	DC Voltmeter or Digital Voltmeter between R79 and Ground	VR4 10 kB (Main Amp P.C Board (L))	-73.0 V	Refer to NOTE 2.
2	L ch +DC Power Supply Voltage Adjustment	DC Voltmeter or Digital Voltmeter between R77 and Ground	VR3 10 kB (Main Amp P.C Board (L))	+73.0 V	Refer to NOTE 2.
3	L ch Center Off-set Voltage Adjustment	DC Voltmeter or Digital Voltmeter between L ch SP OUT ⊕ and ⊖	VR1 1 kB (Main Amp P.C Board (L))	0 ± 0.5 mV	OK if 0 ± 0.5 mV at the beginning of adjustment
4	L ch Idling Current Adjustment	DC Ammeter or Tester between P15 ⊕ and ⊖	VR2 1 kB (Main Amp P.C Board (R))	20 mA	Refer to Fig. 7 and NOTE 3.
5	R ch -DC Power Supply Voltage Adjustment	DC Voltmeter or Digital Voltmeter between R79 and Ground	VR4 10 kB (Main Amp P.C Board (R))	-73.0 V	Refer to NOTE 2.
6	R ch +DC Power Supply Voltage Adjustment	DC Voltmeter or Digital Voltmeter between R77 and Ground	VR3 10 kB (Main Amp P.C Board (R))	+73.0 V	Refer to NOTE 2.
7	R ch Center Off-set Voltage Adjustment	DC Voltmeter or Digital Voltmeter between R ch SP OUT ⊕ and ⊖	VR1 220 B (Main Amp P.C Board (R))	0 ± 0.5 mV	OK if 0 ± 0.5 mV at the beginning of adjustment
8	R ch Idling Current Adjustment	DC Ammeter or Tester between P14 ⊕ and ⊖	VR2 1 kB (Main Amp P.C Board (R))	20 mV	Refer to Fig. 7 and NOTE 3.
9	L ch Meter Sensitivity Adjustment	AC Voltmeter between L ch SP OUT ⊕ and ⊖	VR1 1 kB (Meter P.C Board)	Meter indicates 200 W	Input 1 kHz sine wave & adjust the input level until the AC Voltmeter reads 40.0V. Refer to NOTE 4.
10	L ch LED Sensitivity Adjustment	AC Voltmeter between L ch SP OUT ⊕ and ⊖	VR2 2.2 kB (Meter P.C Board)		Input 1 kHz sine wave, control the output level with the input level, and adjust VR2 so that 0 dB LED will go on at SP output of 40.0V (200W) and off at 35.8V (160W). Refer to NOTE 4.
11	R ch Meter Sensitivity Adjustment	AC Voltmeter between R ch SP OUT ⊕ and ⊖	VR1b 1 kB (Meter P.C Board)	Meter indicates 200 W	Input 1 kHz sine wave & adjust the input level until the AC Voltmeter reads 40.0 V. Refer to NOTE 4.

Step	Adjustment Item	Measuring Instrument Connection	Adjustment Point	Result	Remarks
12	R ch LED Sensitivity Adjustment	AC Voltmeter between R ch SP OUT ⊕ and ⊖	VR2b 2.2 kB (Meter P.C Board)		Input 1 kHz sine wave, control the output level with the input level, and adjust VR2 so that 0 dB LED will go on at SP output of 40.0 V (200 W) and off at 35.8V (160W). Refer to NOTE 4.

Chart-3

- NOTES:**
1. Connect and disconnect a measuring equipment only after the power has turned off for several seconds.
 2. When connecting the Voltmeter for Steps 1, 2, 5 and 6, do not shortcircuit positive and negative power sources.
 3. When connecting the DC Ammeter for Steps 4 and 8, do not touch the angle fixing the P.C Board.
 4. Do adjustments in steps 9 to 12 with the input in only one channel.

VIII. CLASSIFICATION OF VARIOUS P.C BOARDS

1. P.C BOARD TITLES AND IDENTIFICATION NUMBERS

1) Model PS-200C

P.C Board Title	P.C Board Number
Selector P.C Board	PC-2001
Pre Amp P.C Board (Old Type)	PC-2002
Pre Amp P.C Board (B) (New Type)	PC-2056
Power Supply P.C Board	PC-2003
Impedance Selector P.C Board	PC-2033
LED P.C Board (B)	PM-1252
Fuse P.C Board (U) (U/T)	PC-2004
Fuse P.C Board (C) (CSA, AAL)	PC-2034
Fuse P.C Board (E) (CEE, UK)	PC-2035

Chart-4

2) Model PS-120M

P.C Board Title	P.C Board Number
Main Amp P.C Board (L)	PM-1201
Main Amp P.C Board (R)	PM-1202
Filter P.C Board	PM-1203
Meter P.C Board	PM-1204
Temp Compensation P.C Board	PM-1249
LED P.C Board (A)	PM-1250
LED P.C Board (B)	PM-1252
Fuse P.C Board (U) (U/T)	PM-1205
Fuse P.C Board (C) (CSA, AAL)	PM-1248
Fuse P.C Board (E) (CEE, UK)	PM-1251
Relay Terminal P.C Board	PM-1247

Chart-5

3) Model PS-200M

P.C Board Title	P.C Board Number
Main Amp P.C Board (L)	PM-1201
Main Amp P.C Board (R)	PM-1202
Filter P.C Board	PM-1203
Meter P.C Board	PM-2001
Temp Compensation P.C Board	PM-1249
LED P.C Board (C)	PM-2016
LED P.C Board (B)	PM-1252
Fuse P.C Board (U) (U/T)	PM-2017
Fuse P.C Board (C) (CSA, (AAL)	PM-2018
Fuse P.C Board (E) (CEE, UK)	PM-2019
Relay Terminal P.C Board	PM-1247

Chart-6

2. MODEL PS-200C COMPOSITION OF VARIOUS P.C BOARDS

1) PRE AMP P.C BOARD PC-2002 (Old Type)

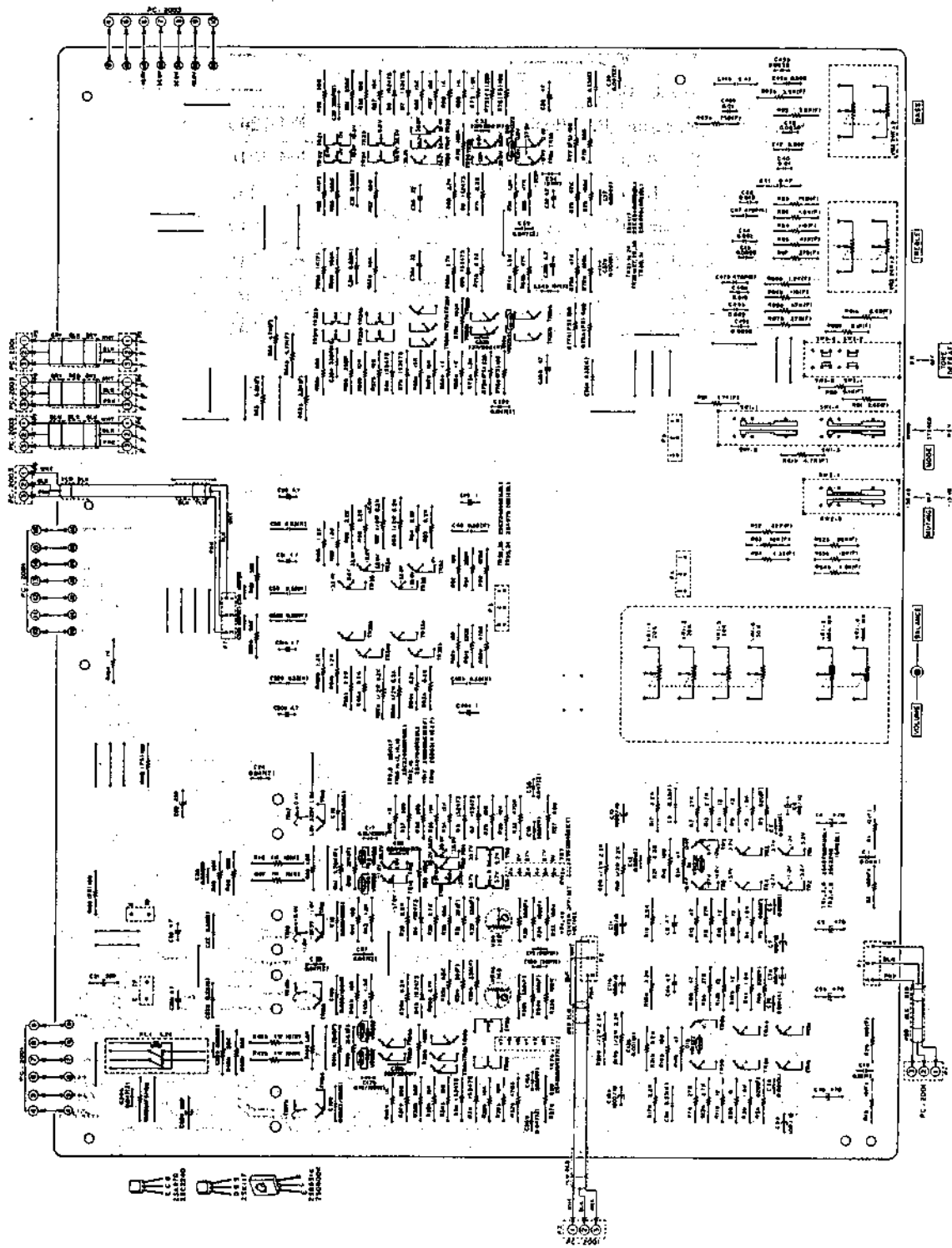

2) PRE AMP P.C BOARD (B) PC-2056 (New Type)

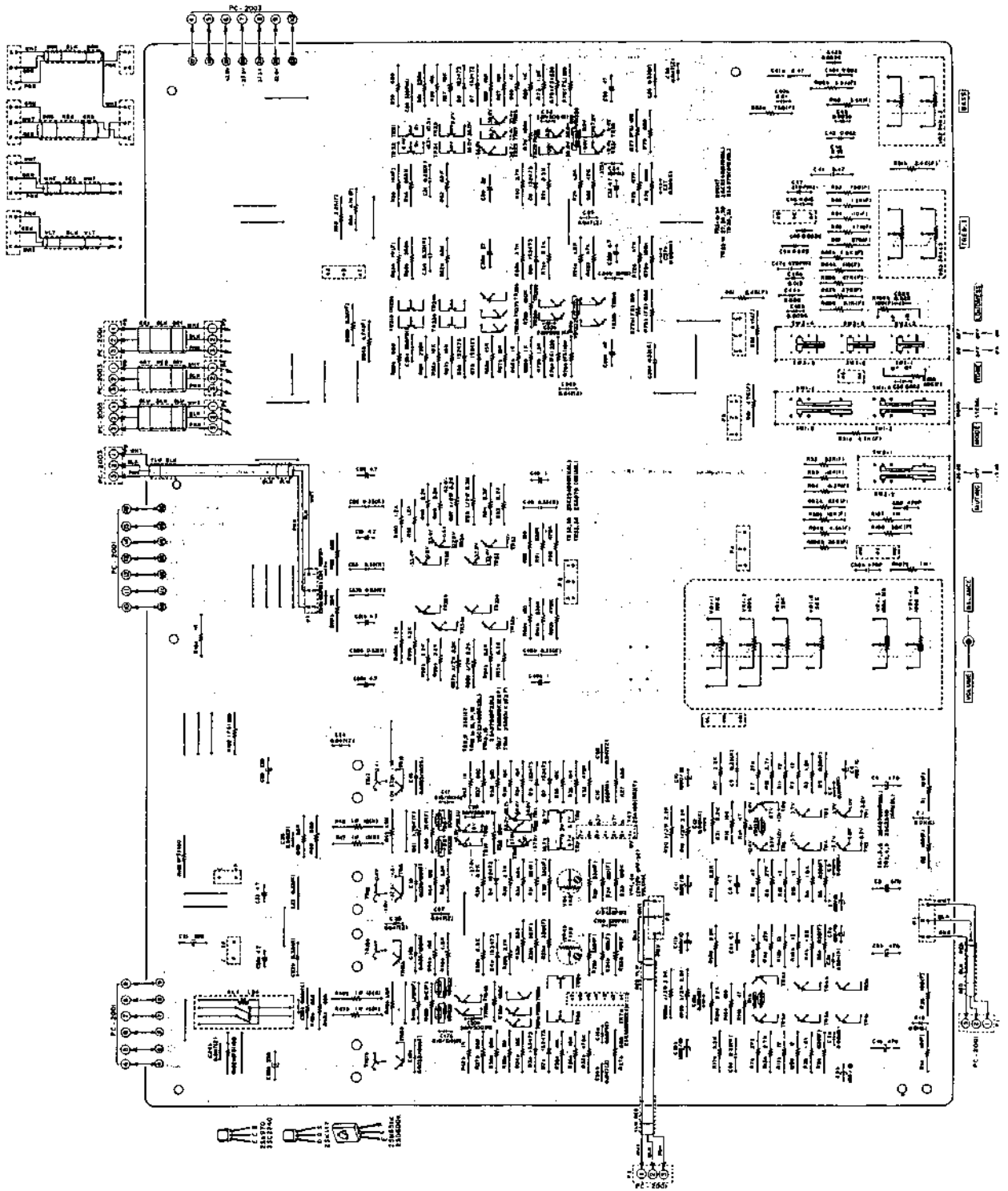

3) SELECTOR P.C BOARD PC-2001, IMPEDANCE SELECTOR P.C BOARD PC-2033 AND LED P.C BOARD (B) PM-1252

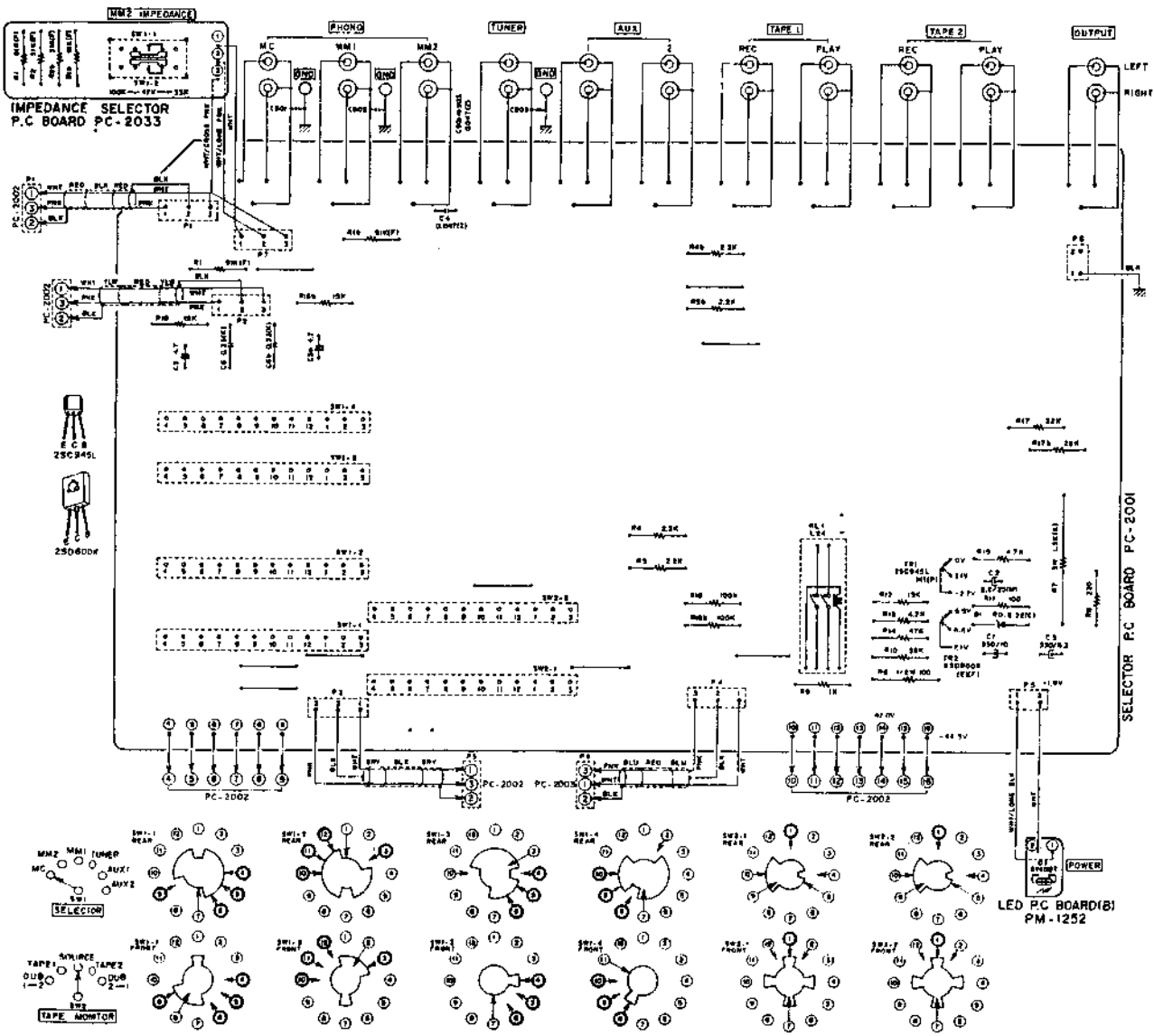

4) POWER SUPPLY P.C BOARD PC-2003

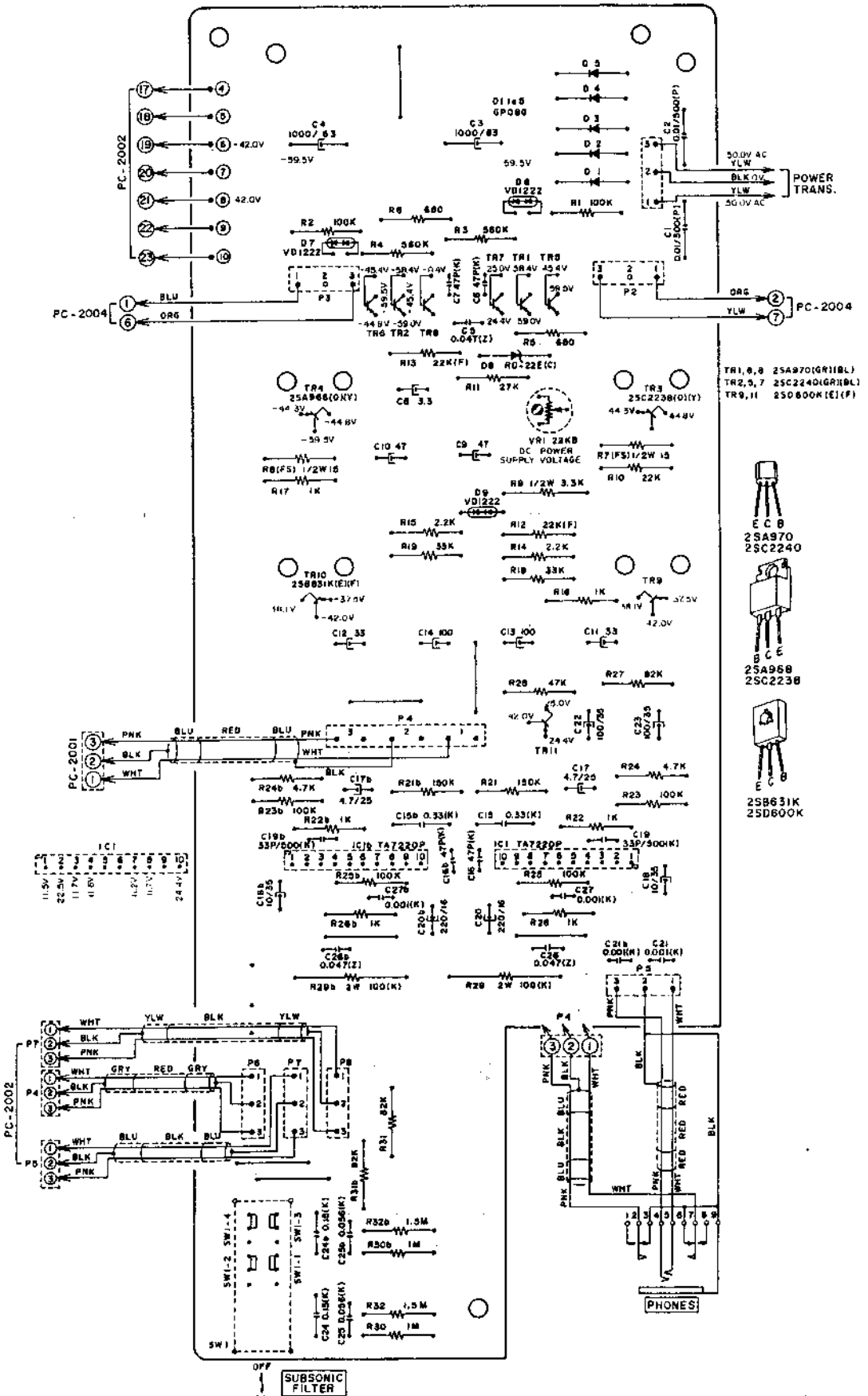

5) FUSE P.C BOARD (U) PC-2004 (U/T)

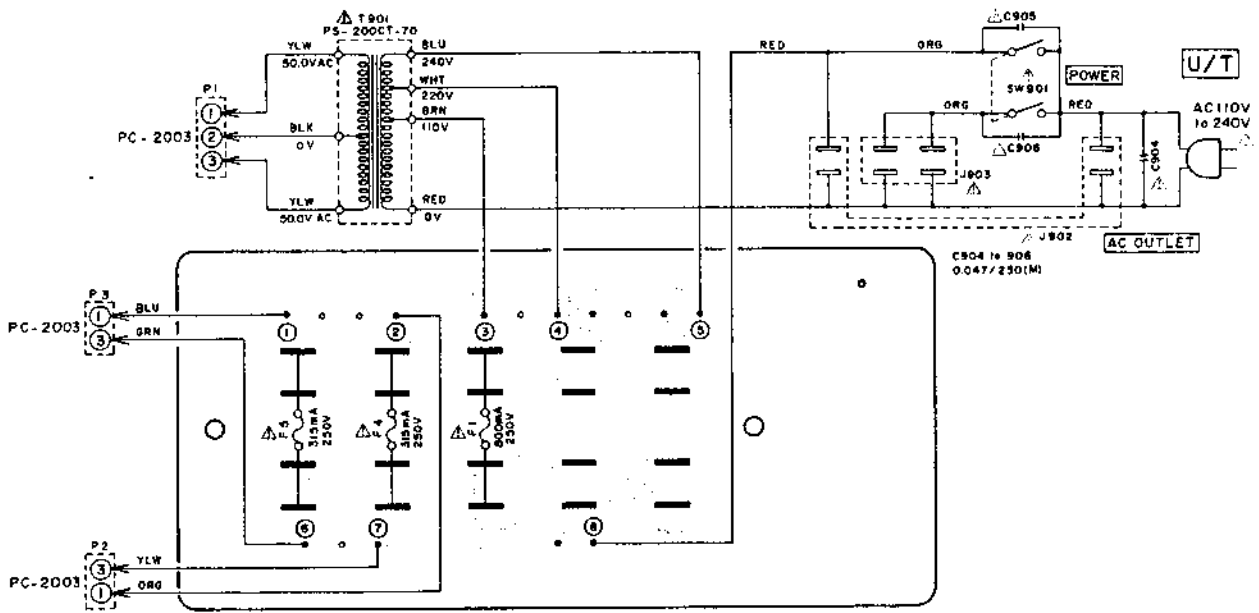

6) FUSE P.C BOARD (C) PC-2034 (CSA, AAL)

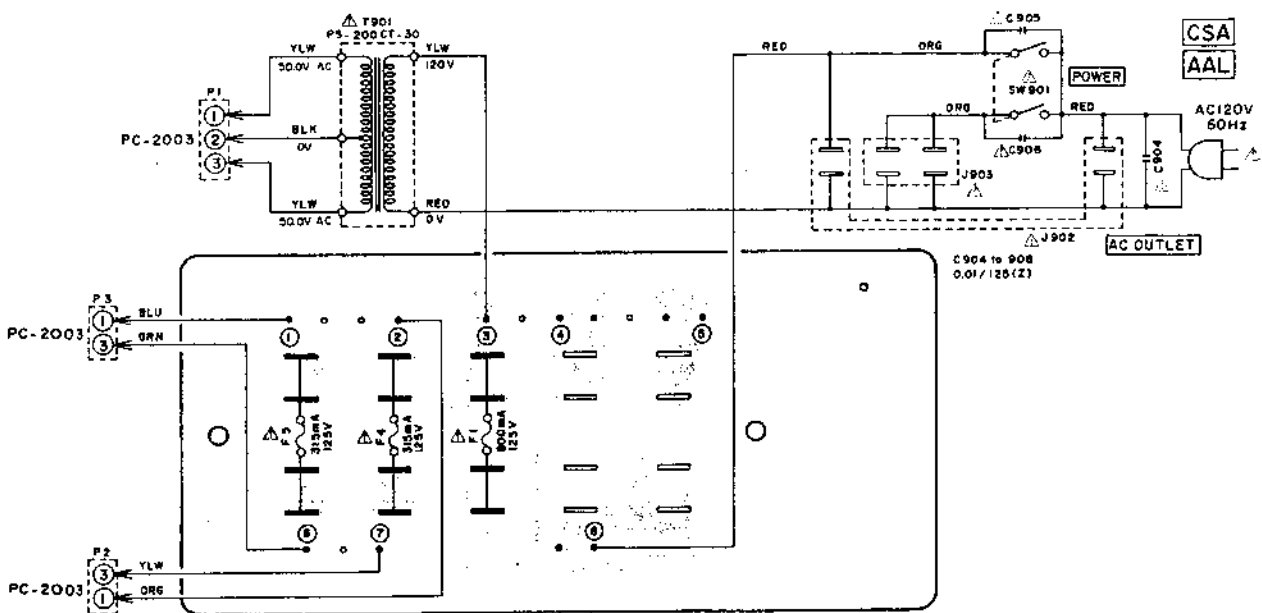

WARNING: INDICATES SAFETY CRITICAL COMPONENTS FOR IDENTIFIED CAPS. ONLY USE SAFETY CRITICAL COMPONENTS ONLY FROM MANUFACTURER'S RECOMMENDED PARTS.
 AVERTISSEMENT: IL INDIQUE LES COMPOSANTS CRITIQUES DE SÛRETÉ. SEULEMENT UTILISER DES COMPOSANTS CRITIQUES DE SÛRETÉ SEULEMENT DES COMPOSANTS RECOMMANDÉS PAR LE FABRICANT.

7) FUSE P.C BOARD (E) PC-2035 (CEE, UK)

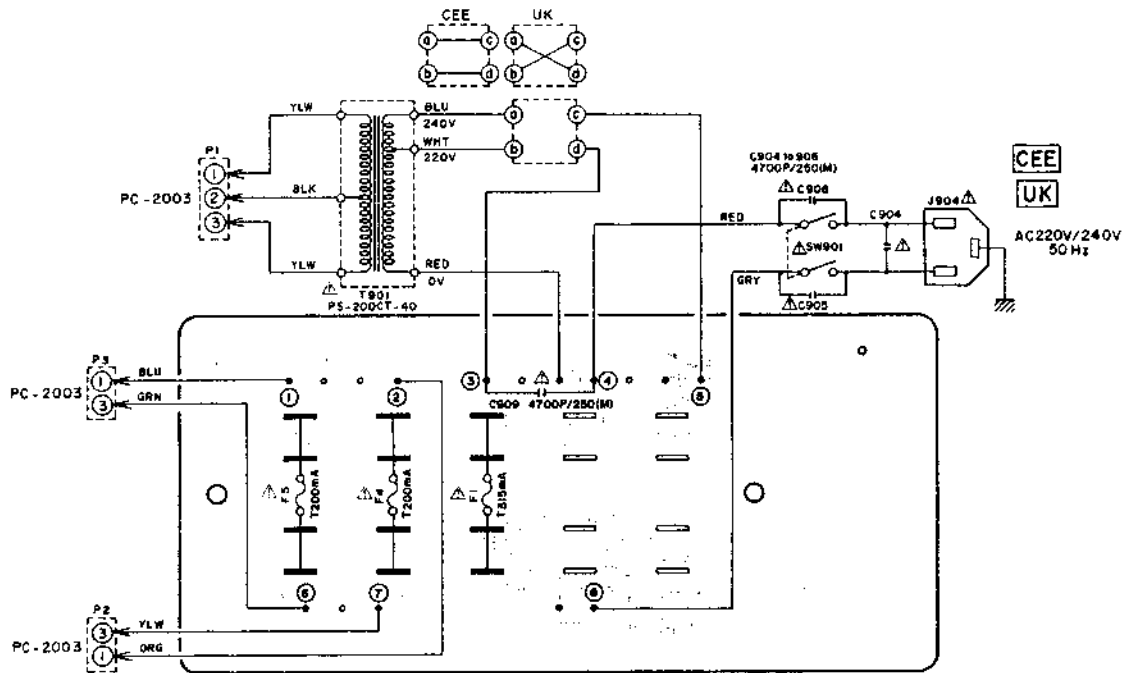

WARNING: ALWAYS USE ONLY ORIGINAL COMPONENTS FOR CONTINUED SAFETY.
 REPLACE SAFETY CRITICAL COMPONENTS ONLY WITH MANUFACTURER'S
 RECOMMENDED PARTS

AVERTISSEMENT: À IL INDIQUE LES COMPOSANTS CRITIQUES DE SÉCURITÉ POUR
 MAINTENIR LE NIVEAU DE SÉCURITÉ DE L'APPAREIL NE REMPLACER LES
 COMPOSANTS QU'À LE FONCTIONNEMENT EST CRITIQUE POUR LA SÉCURITÉ
 SUR TOUTES LES PIÈCES RECOMMANDÉES PAR LE FABRICANT

2) MAIN AMP P.C BOARD (R) PM-1202 AND TEMP. COMPENSATION P.C BOARD PM-1249

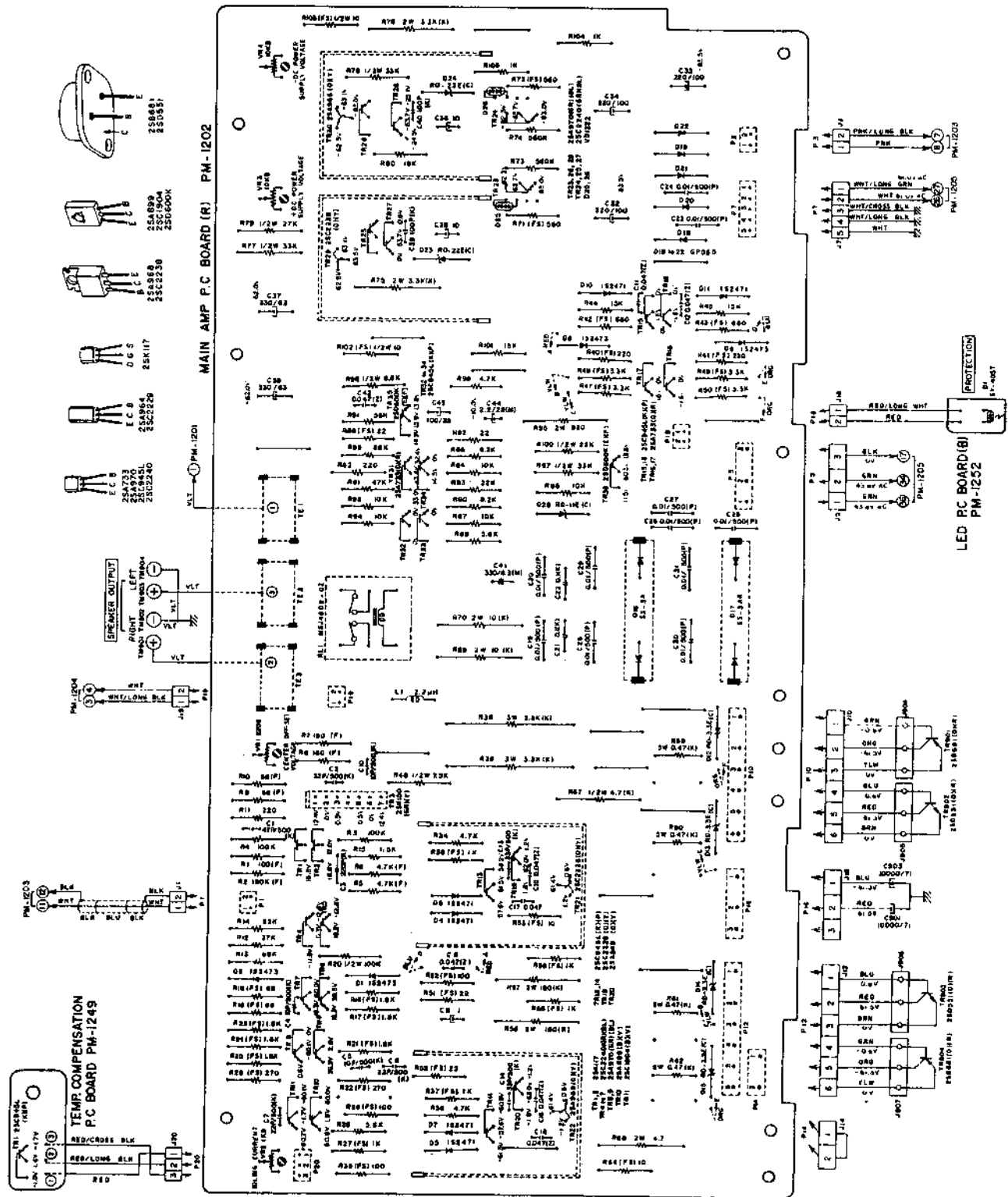

3) FILTER P.C BOARD PM-1203

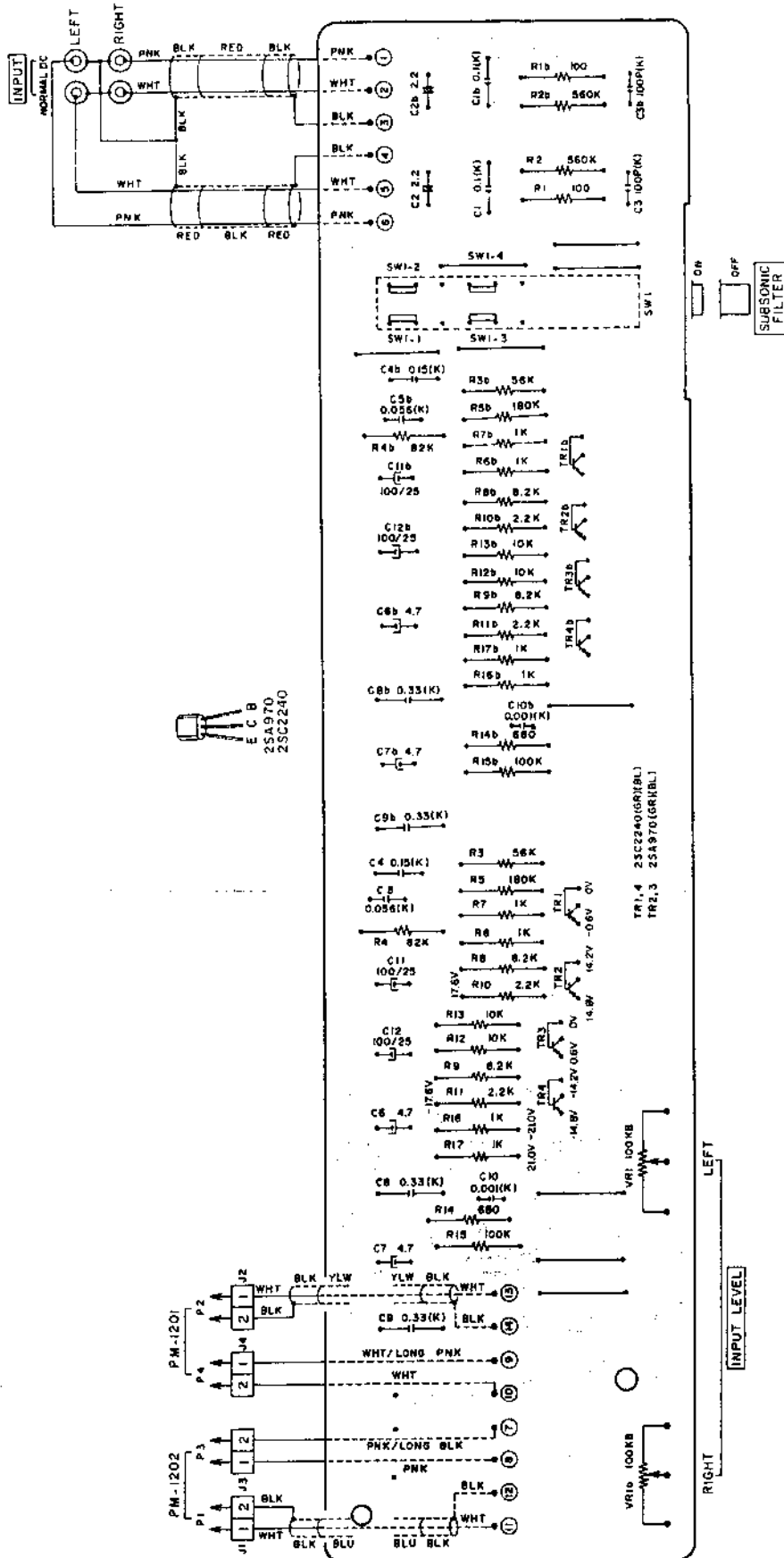

5) FUSE P.C BOARD (U) PM-1205 (U/T)

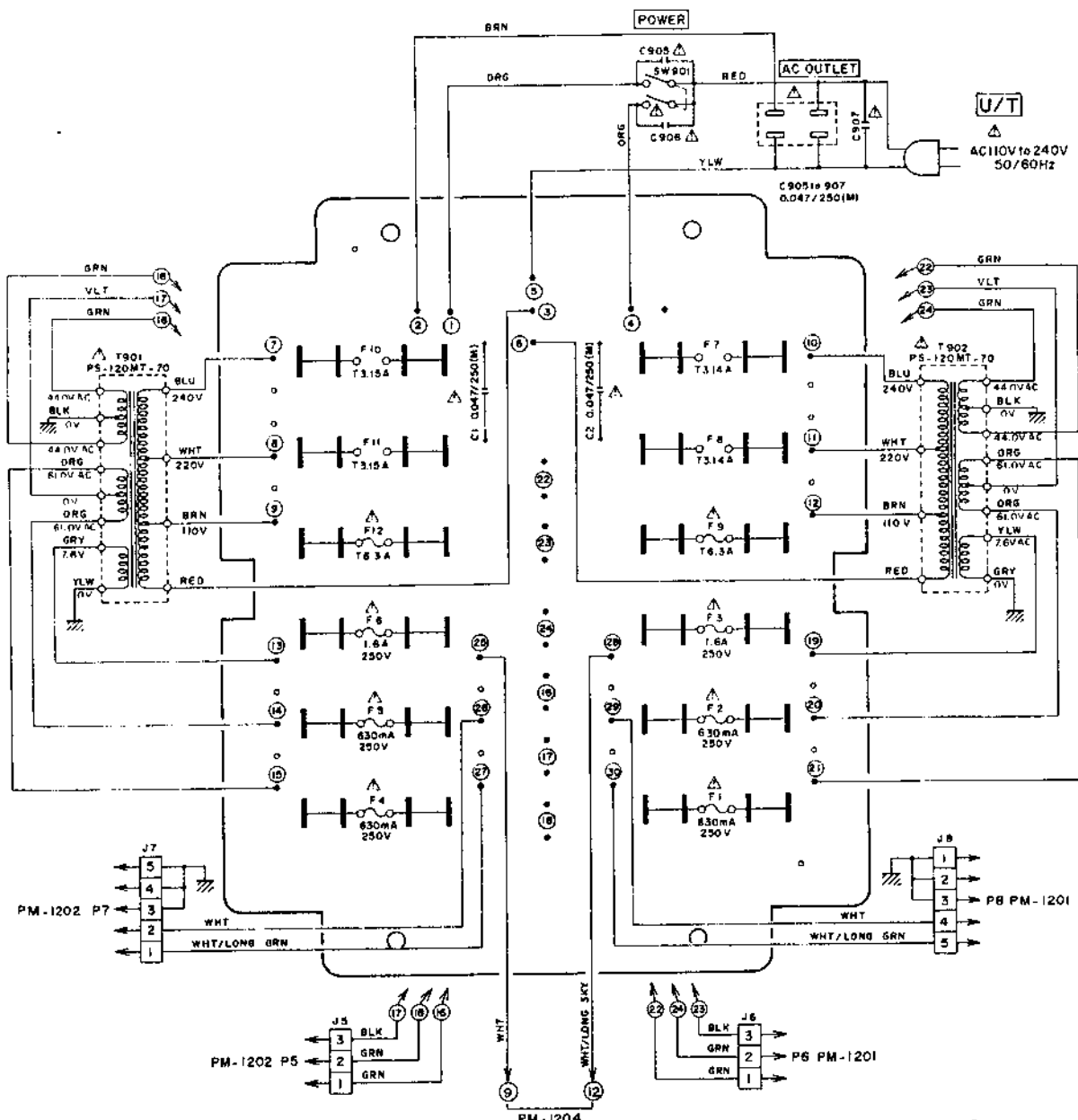

WARNING: IDENTIFY SAFETY CRITICAL COMPONENTS FOR CONTINUED SAFETY. REPLACE SAFETY CRITICAL COMPONENTS ONLY WITH MANUFACTURER'S RECOMMENDED PARTS.
 AVERTISSEMENT: AFINQU'ILS LES COMPOSANTS CRITIQUES DE SÛRETÉ, POUR MAINTENIR LE DEGRÉ DE SÛRETÉ DE L'APPAREIL, NE REMPLACER LES COMPOSANTS DONT LE FONCTIONNEMENT EST CRITIQUE QUE PAR DES PIÈCES RECOMMANDÉES PAR LE FABRICANT.

6) FUSE P.C BOARD (C) PM-1248 AND RELAY TERMINAL P.C BOARD PM-1247 (CSA, AAL)

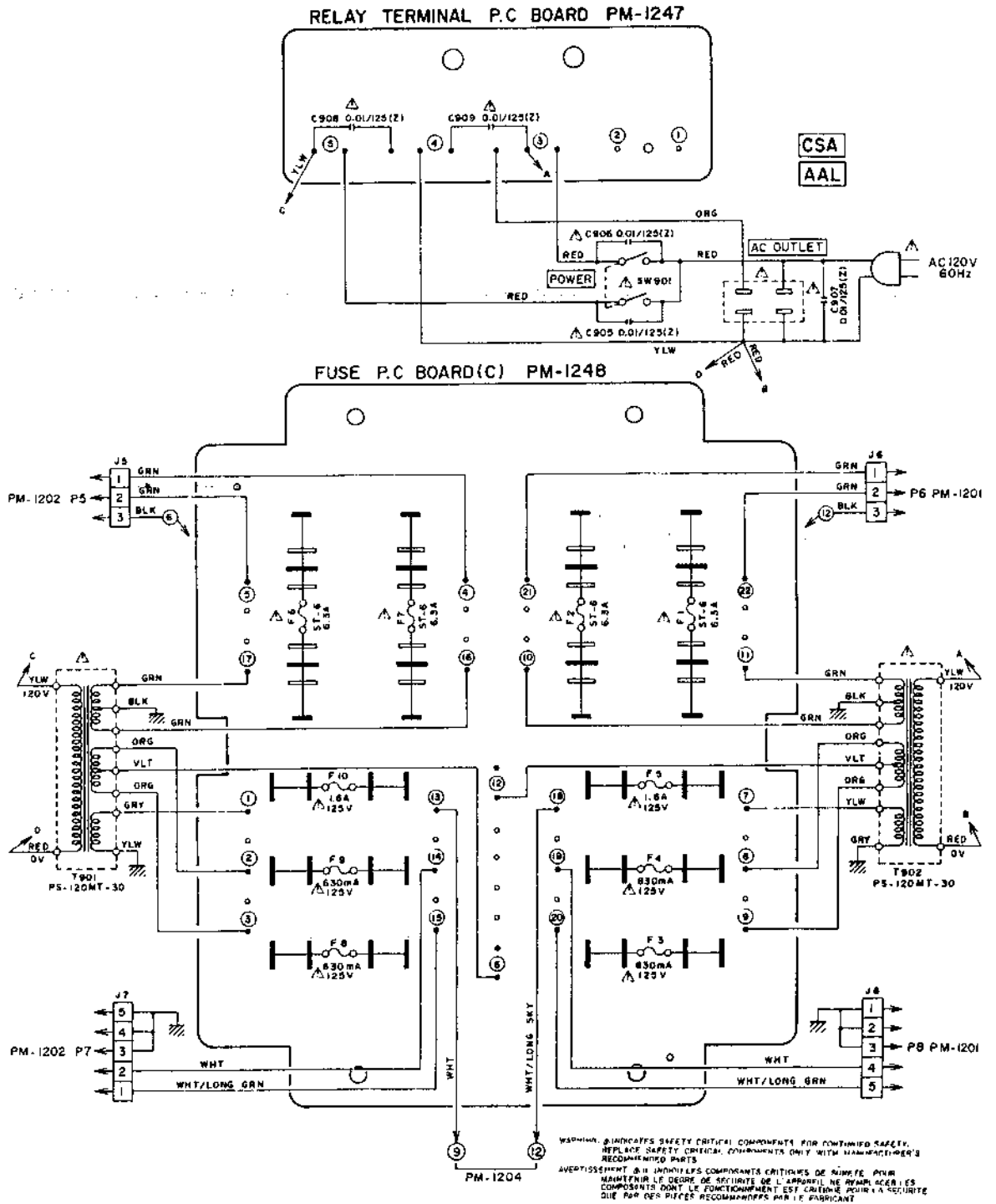

7) FUSE P.C BOARD (E) PM-1251 AND RELAY TERMINAL P.C BOARD PM-1247 (CEE, UK)

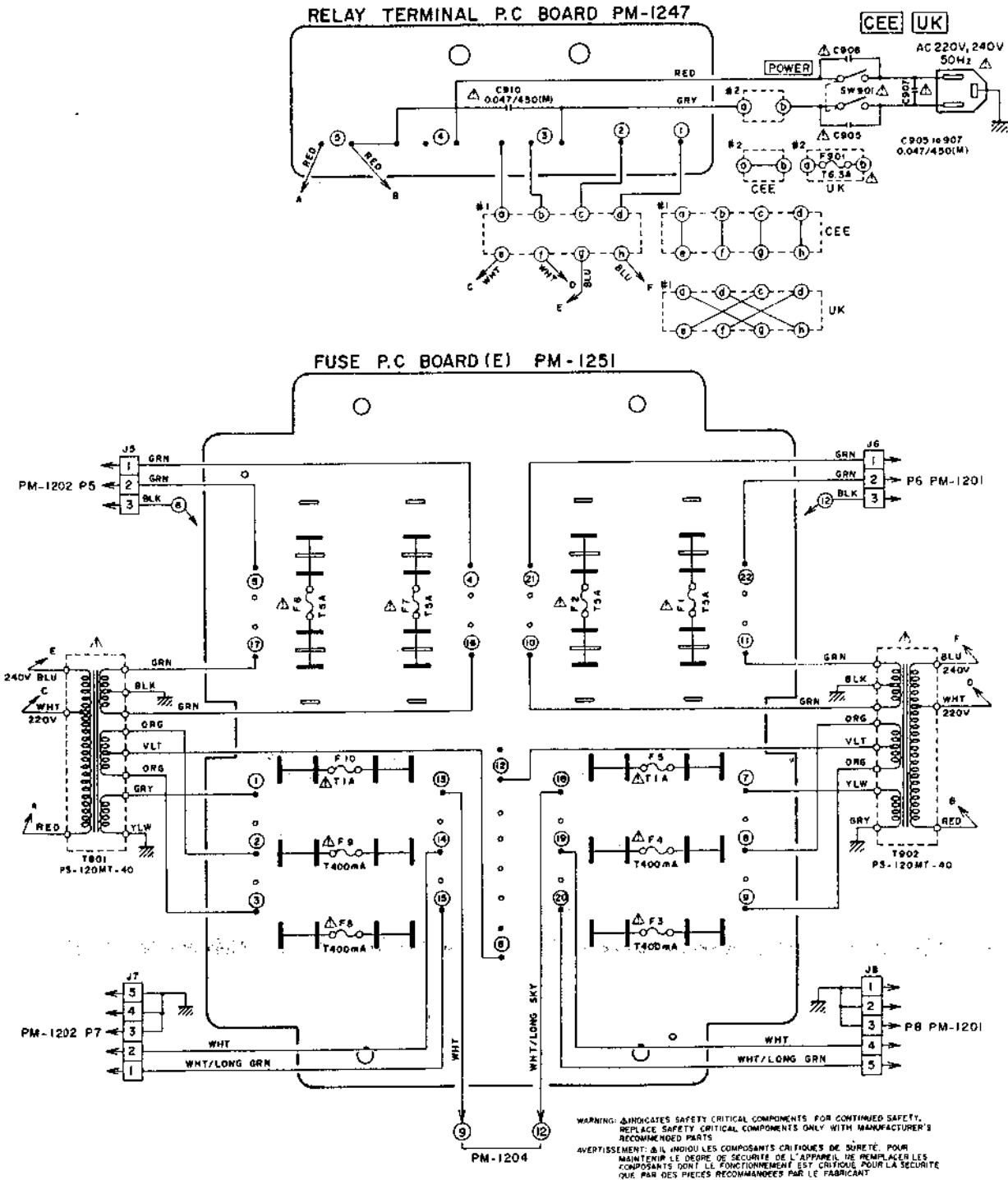

4. MODEL PS-200M COMPOSITION OF VARIOUS P.C BOARDS

1) MAIN AMP P.C BOARD (L) PM-1201 AND TEMP. COMPENSATION P.C BOARD PM-1249

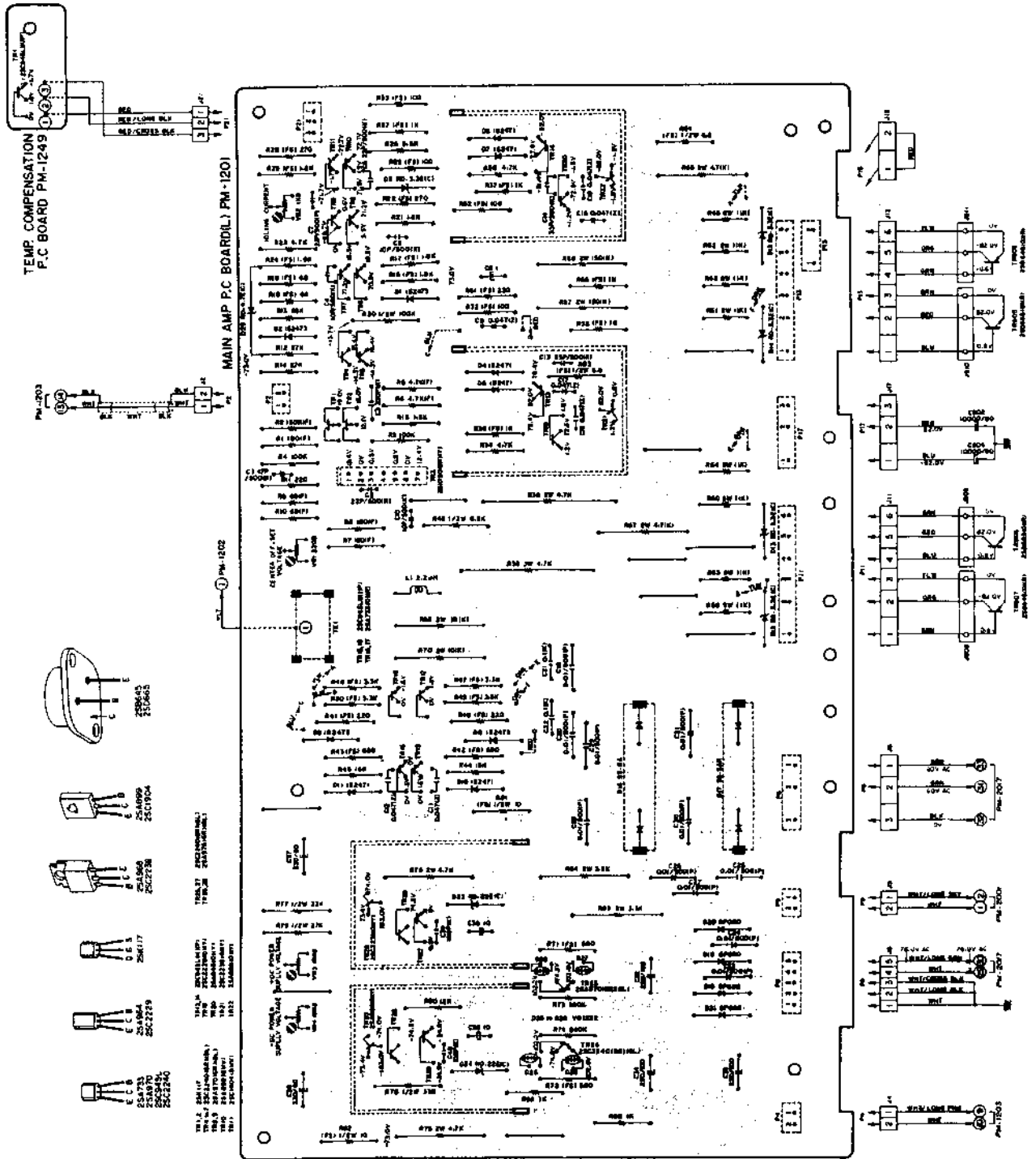

2) MAIN AMP P.C BOARD (R) PM-1202 AND TEMP. COMPENSATION P.C BOARD PM-1249

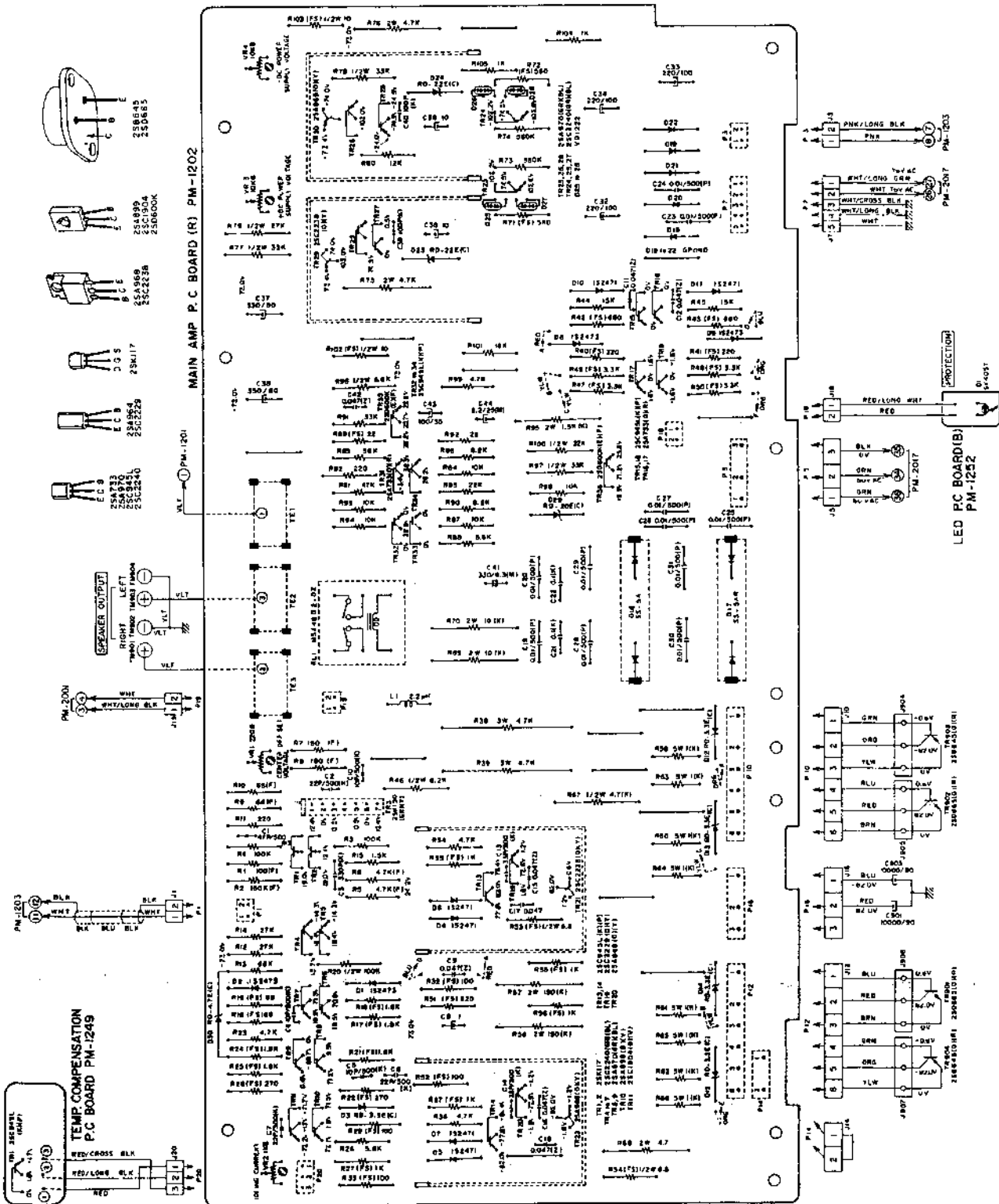

3) FILTER P.C BOARD PM-1203

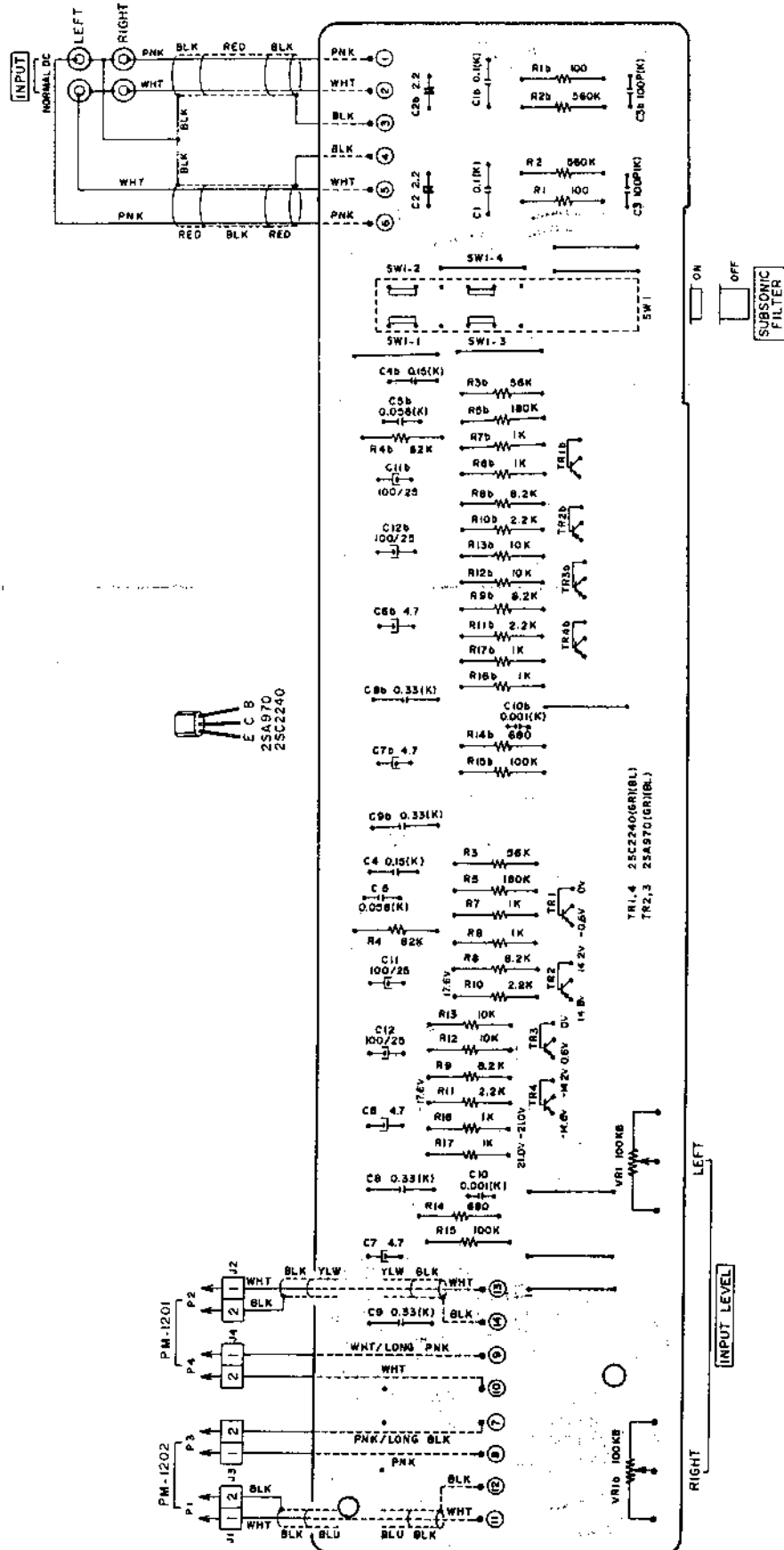

4) METER P.C BOARD PM-2001, LED P.C BOARD (B) PM-1252 AND LED P.C BOARD (C) PM-2016

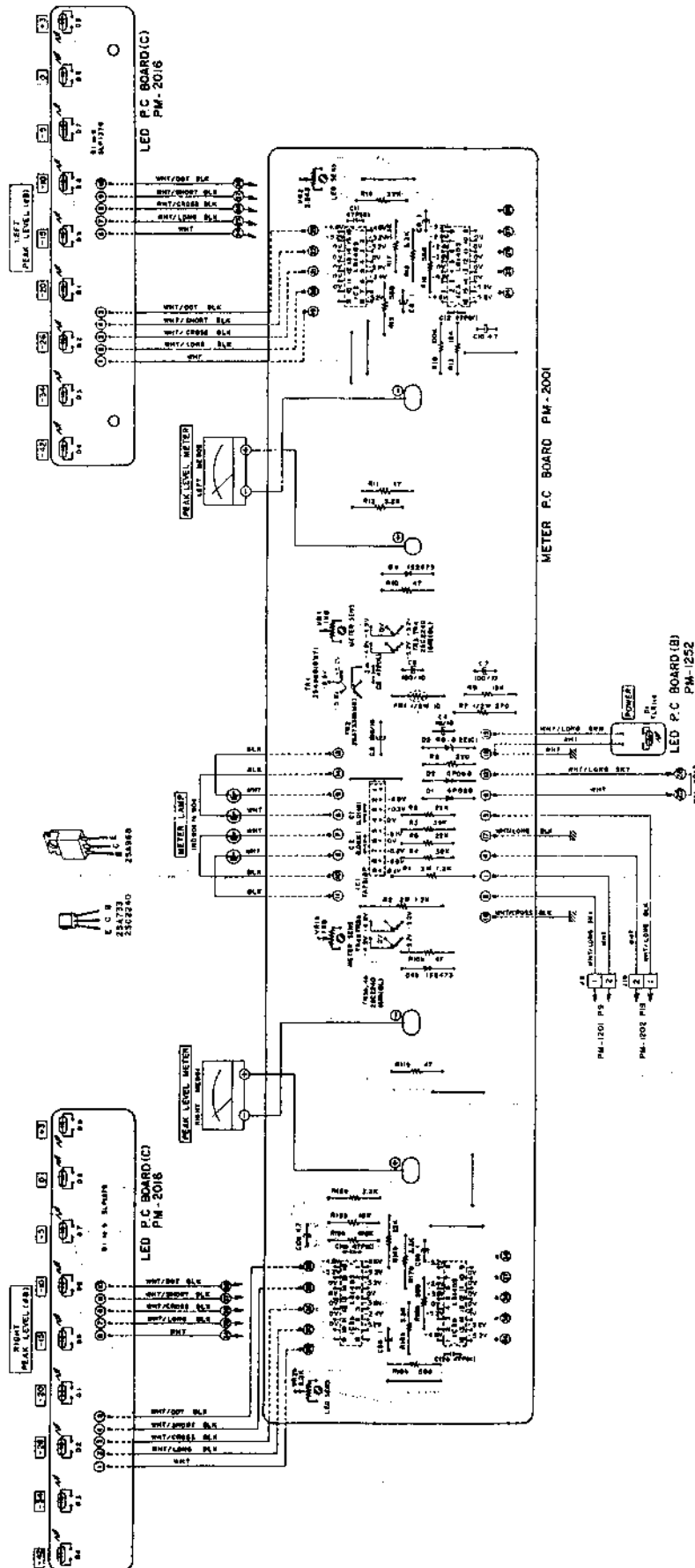

5) FUSE P.C BOARD (U) PM-2017 (U/T)

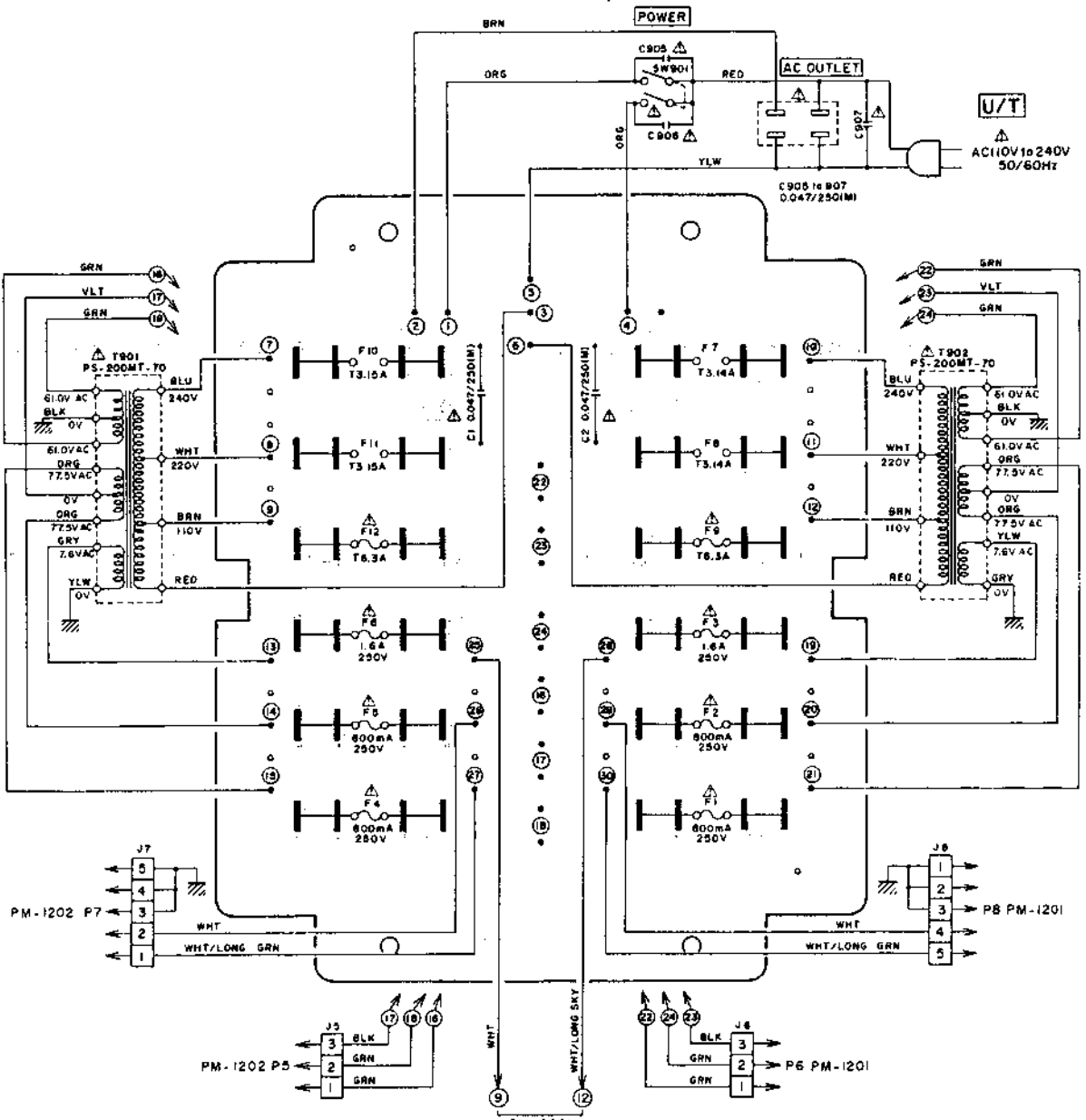

WARNING: Δ INDICATES SAFETY CRITICAL COMPONENTS FOR CONTINUED SAFETY.
 REPLACE SAFETY CRITICAL COMPONENTS ONLY WITH MANUFACTURER'S
 RECOMMENDED PARTS
 AVERTISSEMENT: Δ IL INDIQUE LES COMPOSANTS CRITIQUES DE SURETÉ POUR
 MAINTENIR LE DEGRÉ DE SÉCURITÉ DE L'APPAREIL. NE REMPLACEZ LES
 COMPOSANTS QU'AVEC LE FONCTIONNEMENT EST CRÉÉ POUR LA SÉCURITÉ
 QUE PAR DES PIÈCES RECOMMANDÉES PAR LE FABRICANT

6) FUSE P.C BOARD (C) PM-2018 AND RELAY TERMINAL P.C BOARD PM-1247 (CSA, AAL)

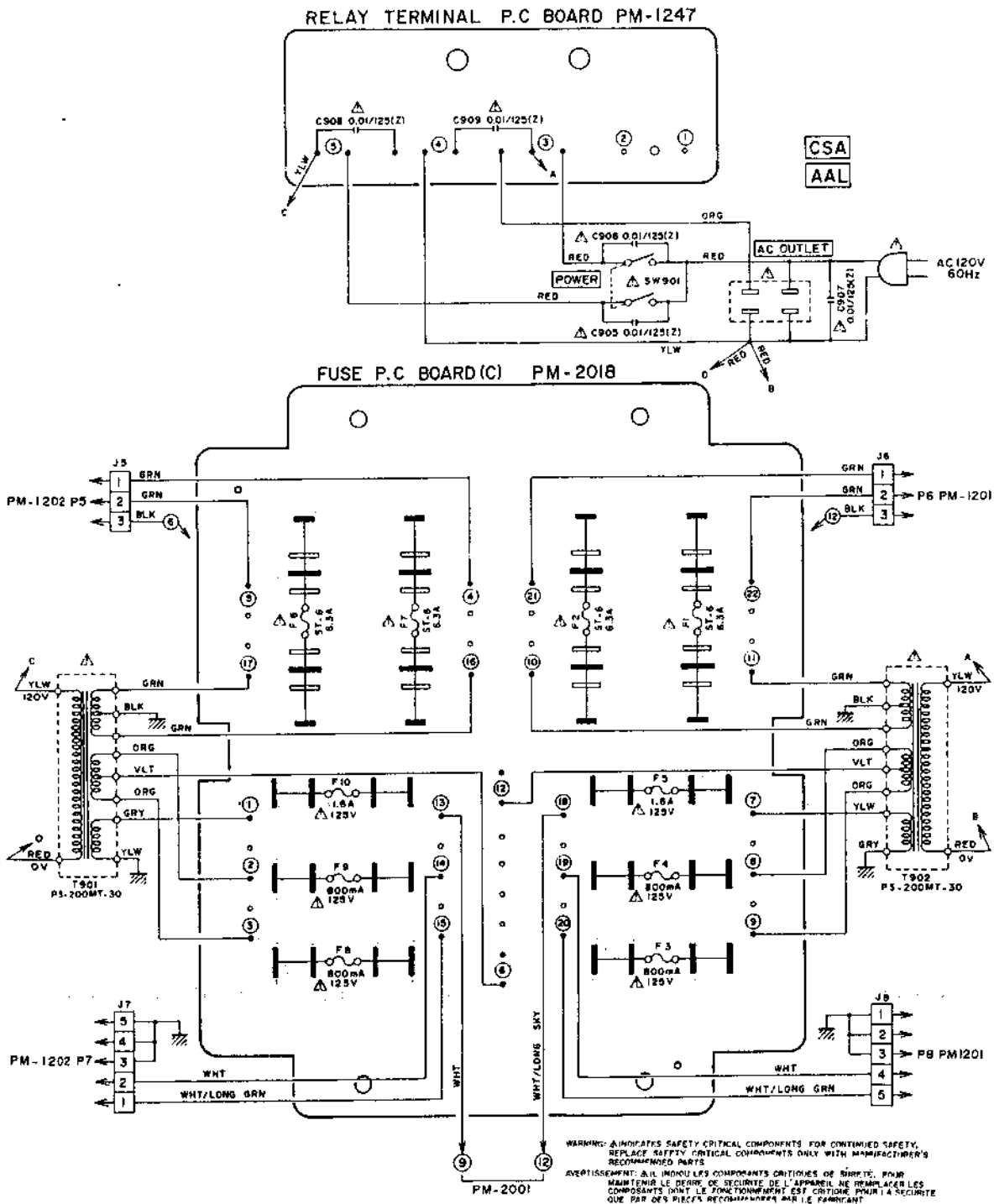

7) FUSE P.C BOARD (E) PM-2019 AND RELAY TERMINAL P.C BOARD PM-1247 (CEE, UK)

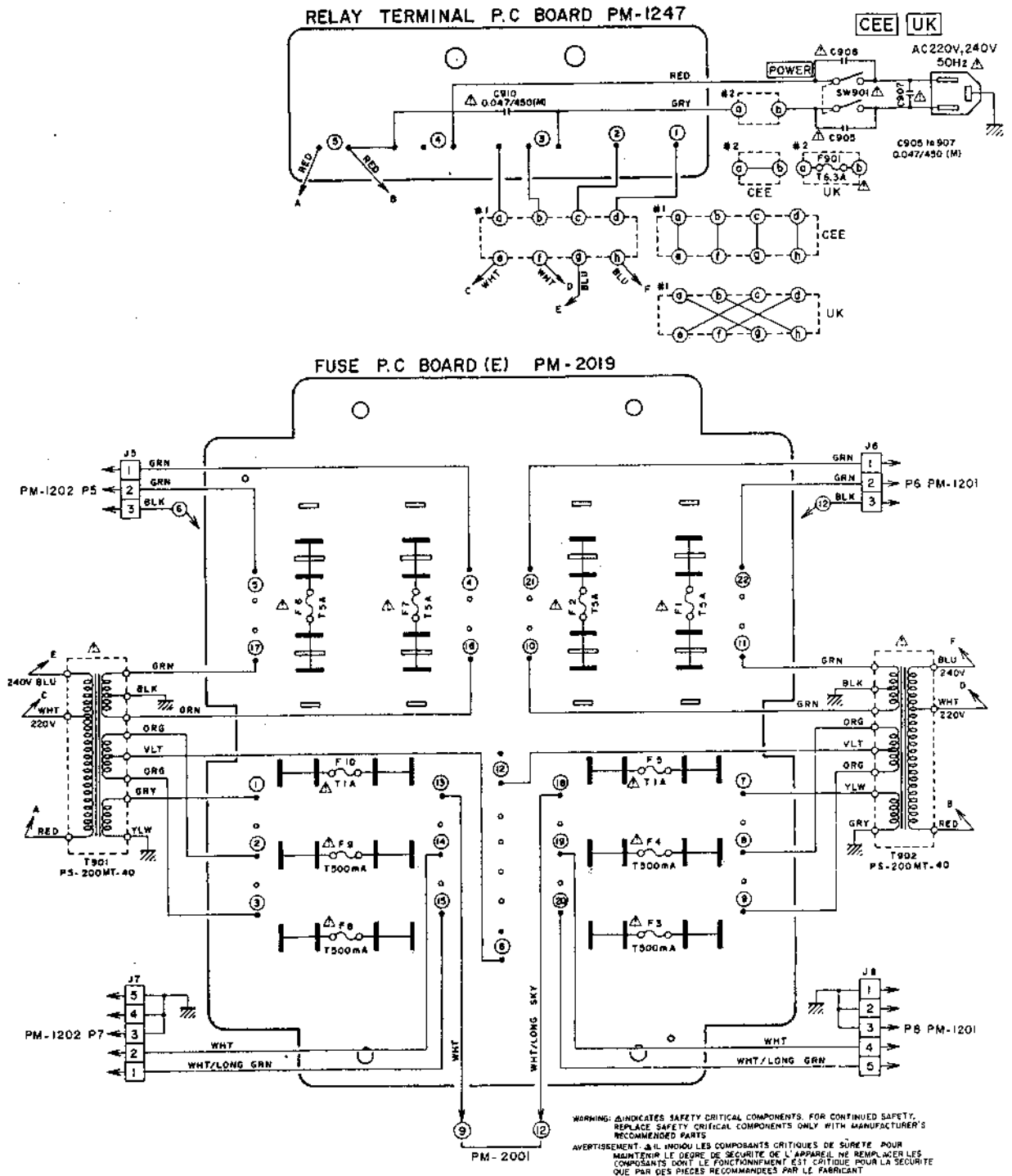

TABLE OF CONTENTS

SECTION 2

PARTS LIST

TABLE OF CONTENTS

I. MODEL PS-200C

1. RECOMMENDED SPARE PARTS LIST	60
2. PRE AMP P.C. BOARD (PC-2056/2056S) BLOCK	61
3. POWER SUPPLY P.C. BOARD (PC-2003/2003S) BLOCK	62
4. SELECTOR P.C. BOARD (PC-2001/2001S) BLOCK	62
5. IMPEDANCE CHANGE P.C. BOARD (PC-2033) BLOCK	63
6. BED P.C. BOARD (PH-12) BLOCK	63
7. ASSEMBLY BLOCK	64
8. FINAL ASSEMBLY BLOCK	64

II. MODEL PS-200M

1. RECOMMENDED SPARE PARTS LIST	65
2. MAIN AMP P.C. BOARD (PM-2010/2010S) BLOCK	66
3. MAIN AMP P.C. BOARD (PM-2010/2010S) BLOCK	66
4. FILTER P.C. BOARD (PM-2063/2063S) BLOCK	67
5. METER P.C. BOARD (PM-2009/2009S) BLOCK	67
6. ASSEMBLY BLOCK	68
7. FINAL ASSEMBLY BLOCK	68

III. MODEL PS-200N

1. RECOMMENDED SPARE PARTS LIST	69
2. MAIN AMP P.C. BOARD (PM-2007/2007S) BLOCK	70
3. MAIN AMP P.C. BOARD (PM-2007/2007S) BLOCK	70
4. FILTER P.C. BOARD (PM-2063/2063S) BLOCK	70
5. METER P.C. BOARD (PM-2009/2009S) BLOCK	70
6. ASSEMBLY BLOCK	70
7. FINAL ASSEMBLY BLOCK	70

INDEX

I. MODEL PS-200C

MODEL PS-200M

MODEL PS-200N

LIST OF REVISED PARTS

HOW TO USE THIS PARTS LIST

1. This parts list is compiled by various individual blocks based on assembly process.
2. When ordering parts, please describe parts number, serial number, and model number in detail.
3. How to read List

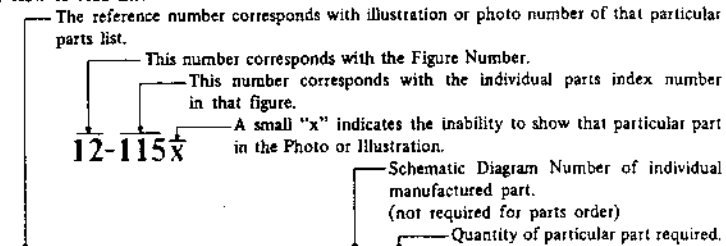

Ref. No.	Parts No.	Description	Schematic No.	Qty
	FLYWHEEL BLOCK #13			
12-115x	800425	Flywheel Block Assy. Comp. RDG #13		1
12-116	244506	Flywheel Only	RD-233	1
12-117x	244754	Felt, Flywheel	RD-275	1
12-118	251324	Main Metal Case	RD-236	1
12-119	253080	Main Metal	RD-237	1

4. The symbol numbers shown on the P.C. Board list can be matched with the Composite Views of Components of the Schematic Diagram or Service Manual.
5. Please utilize separate "Common List for Service Parts" for Resistor Parts orders.
6. The shape of the parts and parts name, etc. can be confirmed by comparing them with the parts shown on the Electrical Parts Table of P.C. Board.
7. Both the kind of part and installation position can be determined by the Parts Number. To determine where a parts number is listed, utilize Parts Index at end of Parts List.
It is necessary first of all to find the Parts Number. This can be accomplished by using the Reference Number listed at right of parts number in the Parts Index. (meaning of ref. no. outlined in Item 3 above).
8. Utilize separate "Price List for Parts" to determine unit price. The most simple method of finding parts Price is to utilize the reference number.

- CAUTION:**
1. When placing an order for parts, be sure to list the parts no., model no., and description. There are instances in which if any of this information is omitted, parts cannot be shipped or the wrong parts will be delivered.
 2. Please be careful not to make a mistake in the parts no. If the parts no. is in error, a part different from the one ordered may be delivered.
 3. Because parts number and parts unit supply in the Preliminary Service Manual (Basic Parts List) may be partially changed, please use this parts list for all future reference.

WARNING: Δ INDICATES SAFETY CRITICAL COMPONENTS. FOR CONTINUED SAFETY, REPLACE SAFETY CRITICAL COMPONENTS ONLY WITH MANUFACTURER'S RECOMMENDED PARTS.

AVERTISSEMENT: Δ IL INDIQU LES COMPOSANTS CRITIQUES DE SURETE. POUR MAINTENIR LE DEGRE DE SECURITE DE L'APPAREIL NE REMPLACER LES COMPOSANTS DONT LE FONCTIONNEMENT EST CRITIQUE POUR LA SECURITE QUE PAR DES PIECES RECOMMANDEES PAR LE FABRICANT.

AC INLET SYSTEM

This model is equipped with an AC INLET SYSTEM. Please refer to the AC INLET SYSTEM CHART below for the specific type. By the AC INLET SYSTEM, AC (mains) cord can be connected to and disconnected from the model because the model is provided with socket exclusively for AC (mains) cord on its main body. Please note, however, that certain models are not equipped with this system and has a built-in AC (mains) cord as before.

AC INLET SYSTEM CHART

CLASS I

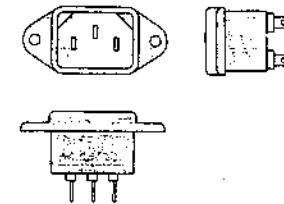

Picture 1
AC INLET to be installed on machines

CLASS II

$\text{\textcircled{a}}$ This mark indicating double insulation will be attached to machine's rear panel

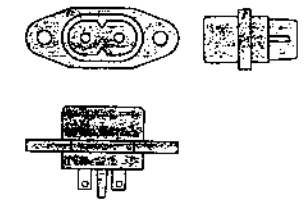

Picture 2
AC (mains) cord

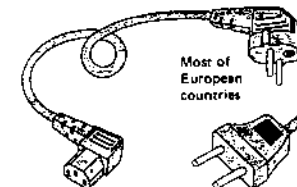

Most of European countries

Connects to machine's AC Inlet

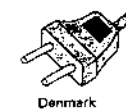

Denmark



U.K.



Australia differs according to wall socket

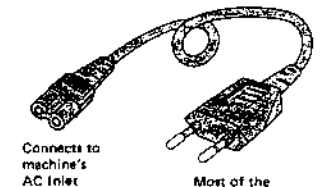

Connects to machine's AC Inlet

Most of the European countries



U.K.

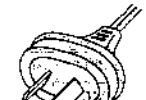

Australia differs according to wall socket

Parts List for AC (mains) Cord Set

	Standard	Description	Type of AC Inlet	Parts No.
Class I	CEE	Cord Set CEE (3 cores)	3P	EW302993
	BEAB	Cord Set BEAB (3 cores)	3P	EW302994
	SAA	Cord Set SAA (3 cores)	3P	EW302996
	U/T	Cord Set U/T (3 cores)	3P	EW302646
Class II	CEE	Cord Set CEE (2 cores)	2P	EW638144
	BEAB	Cord Set BEAB (2 cores)	2P	EW302995
	SAA	Cord Set SAA (2 cores)	2P	EW302991
	U/T	Cord Set U/T (2 cores)	2P	EW302899

I. MODEL PS-200C

1. RECOMMENDED SPARE PARTS LIST

Because, if the parts listed below are on hand, almost any repair can be accomplished, we suggest that you stock these Recommended Spare Parts Items.

Parts No.	Description	Note
BA311370	Power Supply P.C Board Comp. PS-200C	
BA313970	Pre Amp P.C Board Comp. PS-200C	(New Type)
BT311809	△ Power Trans. PS-200CT-30	(CSA)
BT311810	△ Power Trans. PS-200CT-40	(CEE, UK)
BT311811	△ Power Trans. PS-200CT-70	(U/T)
ED311794	LED SY405T	
ED245430	Silicon Diode GP08G	
ED624903	Silicon Diode 1S2473	
ED490511	Varistor VD1222	
ED311752	Zener Diode RD-22E (C)	
ED311853	Zener Diode RD-6.2E (C)	
EF306088	△ Fuse 315mA 125V	(CSA)
EF306125	△ Fuse 315mA 250V	(U/T)
EF309391	△ Fuse 800mA 125V	(CSA)
EF309388	△ Fuse 800mA 250V	(U/T)
EF300596	△ Fuse (FST) 200mA T	(CEE, UK)
EF300598	△ Fuse (FST) 315mA T	(CEE, UK)
EI311789	IC TA72220P	
EP249344	Reed Relay, L Type L24	
ES664222	△ Push SW. SDG-5P TV-5 U/C	SW901 (U/T, CSA)
ES665807	△ Push SW. SDG-5P 5A/80A 250V	SW901 (CEE, UK)
ES311799	Lever SW. SLA22301	
ES311797	Lever SW. SLA24201	(Old Type)
ES311798	Lever SW. SLA24301	
ES315601	Lever SW. SLA26301	(New Type)
ES311803	Rotary SW. SR-26 (PH-2)N 2-4-5 20KC	
ES311802	Rotary SW. SR-26 (PH-2)N 4-8-6 20KC	
ES246227	Slide SW. SSC323E	
ET302465	FET 2SK117 (SPECIAL)	
ET311792	FET 2SK150 (GR) (Y)	
ET311791	Transistor 2SA968 (O) (Y)	
ET305463	Transistor 2SA970 (GR) (BL)	
ET301165	Transistor 2SB631K (E) (F)	
ET311790	Transistor 2SC2238 (O) (Y)	
ET307195	Transistor 2SC2240 (GR) (BL)	
ET300931	Transistor 2SD600K (E) (F)	
EV311795	Double Axial 6-Throw/Vol. (Detent) WKHQ110	(Old Type)
EV315600	Double Axial 6-Throw/Vol. (Detent) WKHQ110C01	(New Type)
EV618052	Semi-Fixed/Vol. CR19R 1KB	
EV312338	Semi-Fixed/Vol. CR19R 22KB	
EV311796	2 Throw/Vol. (Detent) GH30E 24K (SPECIAL)×2	

2. PRE AMP P.C BOARD (PC-2056/2056S)

BLOCK

Symbol No.	Parts No.	Description	Schematic No.	Symbol No.	Parts No.	Description	Schematic No.
2-1	BA313970	Pre Amp P.C Board Comp. PS-200C (New Type)	PC-2056	2-C30	EC311781	NP/C. 22μF 50WV	24-17-33
2-TR1	ET305463	Transistor 2SA970(GR)(BL)	45-1-303	2-C32	EC311780	NP/C. 4.7μF 50WV	24-17-33
2-TR2	ET307195	Transistor 2SC2240(GR)(BL)	45-1-302	2-C35	EC311782	NP/C. 4.7μF 50WV	24-17-33
2-TR3	ET305463	Transistor 2SA970(GR)(BL)	45-1-303	2-C49	EC311778	NP/C. 1μF 50WV	24-17-33
2-TR4,5	ET307195	Transistor 2SC2240(GR)(BL)	45-1-302	2-C50	EC311780	NP/C. 4.7μF 50WV	24-17-33
2-TR6	ET305463	Transistor 2SA970(GR)(BL)	45-1-303	2-C51	EC311780	NP/C. 4.7μF 50WV	24-17-33
2-TR7	ET311792	FET 2SK150(GR)(Y)	45-10-32	2-R1	ER310323	Metal Film/R. 1/4W 10 ohms (F)	35-17-12
2-TR8,9	ET302465	FET 2SK117(SPECIAL)	45-12-16	2-R2	ER311751	Metal Film/R. 1/4W 100 ohms (F)	35-17-12
2-TR10to12	ET307195	Transistor 2SC2240(GR)(BL)	45-1-302	2-R5,6	ER312461	Metal Film/R. 1/4W 820 ohms (F)	35-17-12
2-TR13	ET305463	Transistor 2SA970(GR)(BL)	45-1-303	2-R28,29	ER311875	Metal Film/R. 1/4W 330 ohms (F)	35-17-12
2-TR14,15	ET307195	Transistor 2SC2240(GR)(BL)	45-1-302	2-R31	ER311772	Metal Film/R. 1/4W 39 ohms (F)	35-17-12
2-TR16	ET305463	Transistor 2SA970(GR)(BL)	45-1-303	2-R40	ER311753	Metal Film/R. 1/4W 21 K (F)	35-17-12
2-TR17	ET300931	Transistor 2SD600K(E)(F)	45-1-278	2-R41	ER311754	Metal Film/R. 1/4W 1.78K (F)	35-17-12
2-TR18	ET301165	Transistor 2SB631K(E)(F)	45-1-277	2-R46,47	ER311755	Metal Oxide Film/R. 1W 15 ohms (K)	35-15-10
2-TR21to24	ET302465	FET 2SK117 (SPECIAL)	45-12-16	2-R51	ER311757	Metal Film/R. 1/4W 4.7K (F)	35-17-12
2-TR25to27	ET307195	Transistor 2SC2240(GR)(BL)	45-1-302	2-R52	ER311759	Metal Film/R. 1/4W 82K (F)	35-17-12
2-TR28	ET305463	Transistor 2SA970(GR)(BL)	45-1-303	2-R53	ER311760	Metal Film/R. 1/4W 18K (F)	35-17-12
2-TR29,30	ET307195	Transistor 2SC2240(GR)(BL)	45-1-302	2-R54	ER311761	Metal Film/R. 1/4W 4.3K (F)	35-17-12
2-TR31	ET305463	Transistor 2SA970(GR)(BL)	45-1-303	2-R55	ER310324	Metal Film/R. 1/4W 1K (F)	35-17-12
2-TR32	ET307195	Transistor 2SC2240(GR)(BL)	45-1-302	2-R63	ER311773	Metal Film/R. 1/4W 3.3K (F)	35-17-12
2-TR33,34	ET305463	Transistor 2SA970(GR)(BL)	45-1-303	2-R64	ER311757	Metal Film/R. 1/4W 4.7K (F)	35-17-12
2-TR35	ET307195	Transistor 2SC2240(GR)(BL)	45-1-302	2-R75	ER308849	Carbon/R. F. 1/4W 220 ohms (J)	35-17-25
2-D1	ED490511	Varistor VD1222	45-10-7	2-R76,77	ER307196	Carbon/R. F. 1/4W 100 ohms (J)	35-17-25
2-D2to4	ED624903	Silicon Diode 1S2473	45-1-28	2-R80	ER311762	Metal Film/R. 1/4W 9.1K (F)	35-17-12
2-D5,6	ED490511	Varistor VD1222	45-10-7	2-R81	ER311763	Metal Film/R. 1/4W 2.4K (F)	35-17-12
2-D7to9	ED624903	Silicon Diode 1S2473	45-1-28	2-R82	ER310436	Metal Film/R. 1/4W 3.9K (F)	35-17-12
2-D10	ED490511	Varistor VD1222	45-10-7	2-R83	ER311764	Metal Film/R. 1/4W 750 ohms (F)	35-17-12
2-RL1	EP249344	Reed Relay, L Type L24	47-2-28	2-R84	ER311765	Metal Film/R. 1/4W 110 ohms (F)	35-17-12
2-VR1	EV315600	Double-Axial 6-Throw/Vol. (Detent) WKHQ110C01 (New Type)	36-37-7	2-R85	ER311766	Metal Film/R. 1/4W 47K (F)	35-17-12
2-VR1	EV311795	Double-Axial 6-Throw/Vol. (Detent) WKHQ110 (Old Type)	36-37-3	2-R86	ER311767	Metal Film/R. 1/4W 1.2K (F)	35-17-12
2-VR2	EV311796	2-Throw/Vol. (Detent) GH30E 24K(SPECIAL)×2	36-37-7	2-R87	ER311768	Metal Film/R. 1/4W 270 ohms (F)	35-17-12
2-VR3	EV311796	2-Throw/Vol. (Detent) GH30E 24K(SPECIAL)×2	36-37-7	2-R102,103	ER307196	Carbon/R. F. 1/4W 100 ohms (J)	35-17-25
2-VR4	EV618052	Semi-Fixed/Vol. CR19R 1KB	36-28-4	2-R105	ER310326	Metal Film/R. 1/4W 10K (F)	35-17-12
2-SW1	ES311798	Lever SW. SLA24301	25-12-53	2-R106	ER310328	Metal Film/R. 1/4W 36K (F)	35-17-12
2-SW2	ES311799	Lever SW. SLA22301	25-12-53	2-2	ZS421740	Screw, Pan 3x8 (Black)	
2-SW3	ES315601	Lever SW. SLA26301 (New Type)	25-12-54				
2-SW3	ES311797	Lever SW. SLA24201 (Old Type)	25-12-51				
2-C8	EC311780	NP/C. 4.7μF 50WV	24-17-33				
2-C16	EC312462	Styrol/C. 560PF(K) 50WV	24-11-14				
2-C17	EC311788	Polypro. Film/C. 0.15μF(G) 100WV	24-22-3				
2-C18	EC311787	Polypro. Film/C. 0.039μF(G) 100WV	24-22-3				
2-C19	EC311786	Polypro. Film/C. 0.0033μF(G) 100WV	24-22-3				
2-C23	EC311780	NP/C. 4.7μF 50WV	24-17-33				

When ordering parts, please describe Parts Number, Description, and Model Number in detail.

**3. POWER SUPPLY P.C BOARD
(PC-2003/2003S) BLOCK**

Symbol No.	Parts No.	Description	Schematic No.
3-1	BA311370	Power Supply P.C Board Comp. PS-200C	PC-2004
3-IC1	EI311789	IC TA7220P	45-8-327
3-TR1	ET305463	Transistor 2SA970 (GR) (BL)	45-1-303
3-TR2	ET307195	Transistor 2SC2240 (GR) (BL)	45-1-302
3-TR3	ET311790	Transistor 2SC223B(O)(Y)	45-1-328
3-TR4	ET311791	Transistor 2SA96B(O)(Y)	45-1-338
3-TR5	ET307195	Transistor 2SC2240 (GR) (BL)	45-1-302
3-TR6	ET305463	Transistor 2SA970 (GR) (BL)	45-1-303
3-TR7	ET307195	Transistor 2SC2240 (GR) (BL)	45-1-302
3-TR8	ET305463	Transistor 2SA970 (GR) (BL)	45-1-303
3-TR9	ET300931	Transistor 2SD600K(E)(F)	45-1-278
3-TR10	ET301165	Transistor 2SB631K(E)(F)	45-1-277
3-TR11	ET300931	Transistor 2SD600K(E)(F)	45-1-278
3-D1105	ED245430	Silicon Diode GP08G	45-2-68
3-D6,7	ED490511	Varistor VD1222	45-10-7
3-D8	ED311752	Zener Diode RD-22E (C)	45-6-72
3-D9	ED490511	Varistor VD1222	45-10-7
3-SW1	ES311797	Lever SW. SLA24201	25-12-51
3-VR1	EV312338	Semi-Fixed/Vol. CR19R 22KB	36-29-4
3-R7	ER312460	Carbon/R. F 1/2W 15 ohms (I)	35-11-27
3-R12,13	ER311748	Metal Film/R. 1/4W 22K (F)	35-17-12
3-R29	ER483287	Metal Oxide Film/R. 2W 100 ohms (K)	35-15-8
3-2	ZS421740	Screw, Pan 3x8 (Black)	

**4. SELECTOR P.C BOARD
(PC-2001/2001S) BLOCK**

Symbol No.	Parts No.	Description	Schematic No.
4-TR1	ET635220	Transistor 2SC945L(K)(P)	45-1-85
4-TR2	ET300931	Transistor 2SD600K(E)(F)	45-1-278
4-D1	ED311853	Zener Diode RD-6.2E(C)	45-6-72
4-RL1	EP249344	Reed Relay 1. Type L24	47-2-28
4-SW1	ES311802	Rotary SW. SR-26(PH-2)N 4-8-6 20KC	25-4-164
4-SW2	ES311803	Rotary SW. SR-26(PH-2)N 2-4-5 20KC	25-4-165
4-J1	EJ312463	6P Pin Jack	31-5-147
4-J2	EJ293376	6P Pin Jack	31-1-198
4-J3,4	EJ293365	4P Pin Jack	31-1-197
4-J5	EJ312464	2P Pin Jack	31-5-148
4-C2	EC662128	Solid Aluminum/C. (Vert.) 2.2µF(M) 25WV	24-19-1
4-C5	EC311780	NP/C. 4.7µF 50WV	24-17-23
4-R1	ER311774	Metal Film/R. 1/4W 91K (F)	35-17-12
4-R7	ER311876	Metal Oxide Film/R. 3W 1.5K (K)	35-15-9

**5. IMPEDANCE CHANGE P.C BOARD
(PC-2033) BLOCK**

Symbol No.	Parts No.	Description	Schematic No.
5-SW1	ES246227	Slide SW. SSC323E	25-3-119
5-R1	ER311774	Metal Film/R. 1/4W 91K (F)	35-17-12
5-R2	ER311775	Metal Film/R. 1/4W 51K (F)	35-17-12

6. LED P.C BOARD (PM-1252) BLOCK

Symbol No.	Parts No.	Description	Schematic No.
6-D1	ED311794	LED SY405T	45-15-24

7. ASSEMBLY BLOCK

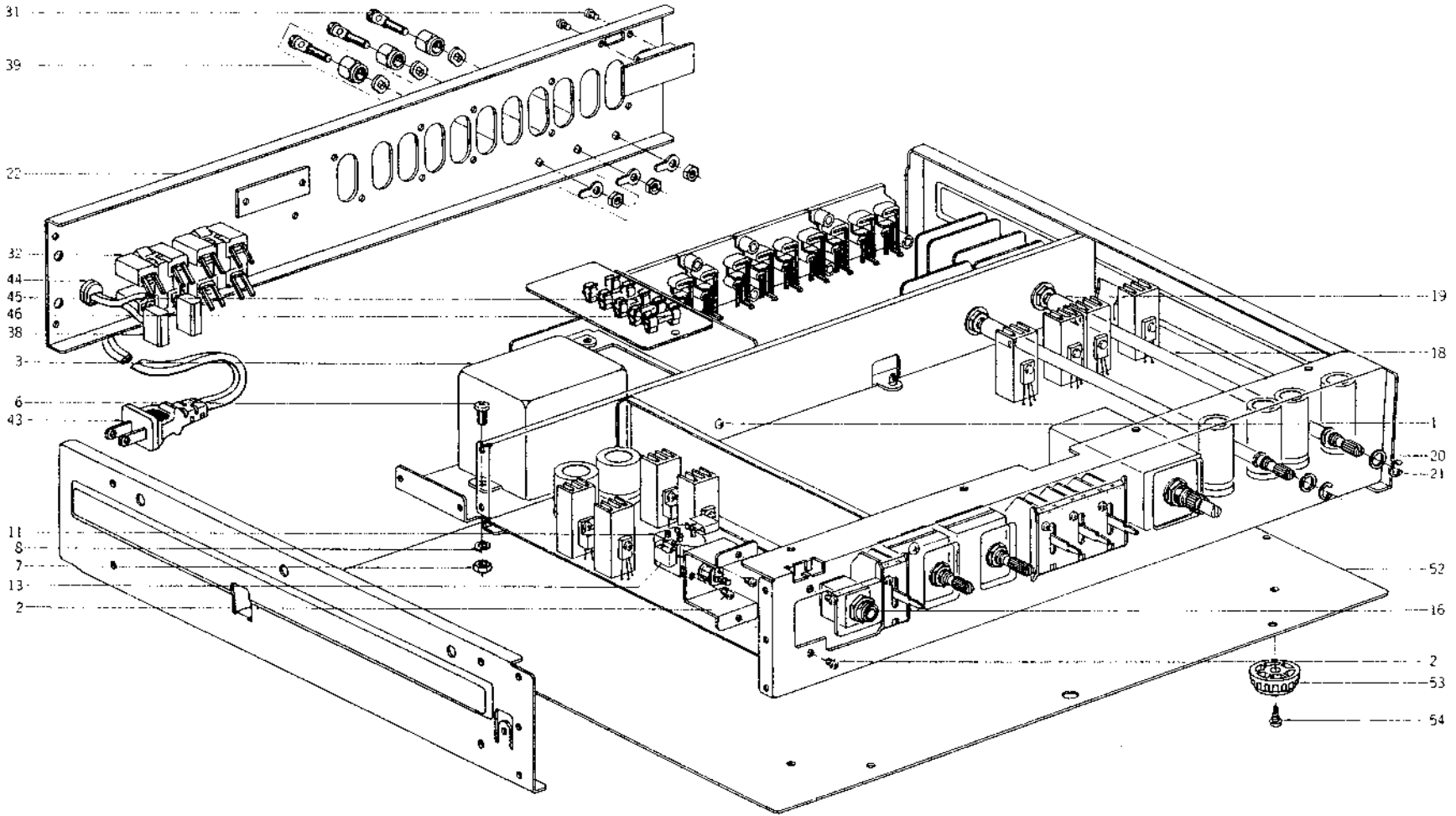

7. ASSEMBLY BLOCK

Ref. No.	Parts No.	Description	Schematic No.
7-1	ZS308846	Tapping Screw, #2, 3x8 (BR) (Oval Neck)	7-1-69
7-2	ZS608477	Screw, Pan 3x4	
7-3	BT311811	Δ Power Trans. PS-200CT-70 (U/T)	24-4-685
7-4x	BT311809	Δ Power Trans. PS-200CT-30 (CSA)	24-4-687
7-5x	BT311810	Δ Power Trans. PS-200CT-40 (CEE, UK)	24-4-686
7-6	ZS537066	Screw, Blind 4x8 (Black)	
7-7	ZW413188	Nut, #1, M4	
7-8	ZW273914	Spring Washer, M4	
7-9x	ZS201778	Screw, Pan 4x6	
7-10x	ZW413188	Nut, #1, M4	
7-11	ES664222	Δ Push SW. SDG-5P TV-5 U/C (U/T, CSA)	25-5-202
7-12x	ES665807	Δ Push SW. SDG-5P 5A/80A 250V (CEE, UK)	25-5-182
7-13	EC283375	Δ MP/C. 0.047μF(M) 250WV (U/T)	24-9-118
7-14x	EC286198	Δ Ceramic/C. AL-10 0.01μF(Z) 125WV (CSA)	24-5-89
7-15x	EC301320	Δ MP/C. 4700PF(M) 250WV (CEE, UK)	24-9-122
7-16	EJ311808	Headphone Jack	31-2-100
7-17x	ZS311745	Tapping Screw, #2, 3x8 (BR) W=8 (Black)	
7-18	MS311709	Relay Shaft	PC-2068
7-19	TA646773	Joint	AA5240
7-20	ZW322110	Washer (Nylon) D6.1x10x1T	
7-21	ZW270123	'E' Ring 4M	6-1-9
7-22	SP311718	Rear Panel (U) (U/T)	PC-2014
7-23x	SP311719	Rear Panel (A) (CSA)	PC-2014
7-24x	SP311720	Rear Panel (E) (CEE)	PC-2015
7-25x	SP311721	Rear Panel (B) (UK)	PC-2015
7-26x	ZW312470	Nut, M9	25-6-164
7-27x	ZW312471	Washer D9	25-6-164
7-28x	ZW312472	Nut, M9	25-6-165
7-29x	ZW312473	Washer D9	25-6-165
7-30x	ZS22865	Tapping Screw, #2, 3x12 (BR) (Black)	
7-31	ZS608185	Screw, Pan 2.6x4	
7-32	EZ225145	Δ 2-Throw AC Outlet (U/T, CSA)	31-1-166
7-33x	EJ296853	Δ 3P Inlet CM-3 (CEE, UK)	31-1-199
7-34x	ZS463353	Tapping Screw, #2, 3x6 (BR) (Black)	
7-35x	EC301320	Δ MP/C. 4700PF(M) 250WV (CEE, UK)	24-9-122
7-36x	EC286198	Δ Ceramic/C. AL-10 0.01μF(Z) 125WV (CSA)	24-5-89
7-37x	EC301320	Δ MP/C. 4700PF(M) 250WV (CEE, UK)	24-9-122
7-38	EC283375	Δ MP/C. 0.047μF(M) 250WV (U/T)	24-9-118
7-39	EJ311812	Earth Terminal	32-1-97
7-40x	EC427228	Ceramic/C. DD111FZ 0.047μF(Z) 50WV	24-5-85
7-41x	EC427228	Ceramic/C. DD111FZ 0.047μF(Z) 50WV	24-5-85
7-42x	EC427228	Ceramic/C. DD111FZ 0.047μF(Z) 50WV	24-5-85
7-43	EW311816	Δ Power Cord 125V 13A (U/T, CSA)	26-3-75
7-44	EZ631945	Strain Relief SR-4N-4 (U/T, CSA)	27-4-9
7-45	EF309388	Δ Fuse 800MA 250V (U/T)	39-1-64
7-46	EF306125	Δ Fuse 315MA 250V (U/T)	39-1-64
7-47x	EF309391	Δ Fuse 800MA 125V (CSA)	39-1-65
7-48x	EF306088	Δ Fuse 315MA 125V (CSA)	39-1-65
7-49x	EF300598	Δ Fuse (FST) 315MAT (CEE, UK)	39-1-61
7-50x	EF300596	Δ Fuse (FST) 200MAT (CEE, UK)	39-1-61

Ref. No.	Parts No.	Description	Schematic No.
FINAL ASSEMBLY BLOCK			
7-51x	ZS311746	Tapping Screw, #2, 3x8 (Oval Neck)	7-1-69
7-52	SP311722	Bottom Plate	PC-2016
7-53	SA311742	Circular Foot	PC-2032
7-54	ZS311747	Tapping Screw, #2, Pan 4x8 (Black)	

8. FINAL ASSEMBLY BLOCK

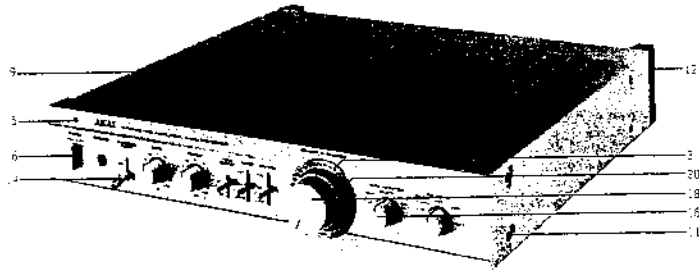

8. FINAL ASSEMBLY BLOCK

Ref. No.	Parts No.	Description	Schematic No.
FRONT PANEL BLOCK			
8-1	BD313972	Front Panel Block Comp. PS-200C (New Type)	
8-2x	BD313973	Front Panel Block Comp. PS-200C-BL (New Type)	
8-3	TA311726	Memory Plate	PC-2019/2020
8-4x	TA311727	Memory Plate (BL)	PC-2019/2020
8-5	SE311728	Power Lens	PC-2021
8-6	SB312474	Button	PC-2042
8-7x	SB312475	Button (BL)	PC-2042
8-8x	ZG312478	Spring	PC-2045
FINAL ASSEMBLY BLOCK			
8-9	BC311730	Case	PC-2023
8-10x	BC312352	Case (BL)	PC-2023
8-11	ZS537006	Screw, Bind 4x8 (Black)	
8-12	SA311714	Foot	PC-2029
8-13x	ZS411232	Screw, Bind 4x8	
8-14	ML311733	Lever (B)	PC-2025
8-15x	ML311734	Lever (B-BL)	PC-2025
8-16	SK311735	Knob	PC-2026
8-17x	SK311736	Knob (BL)	PC-2026
8-18	SK311737	Double Knob (Upper)	PC-2027
8-19x	SK311738	Double Knob (Upper-BL)	PC-2027
8-20	SK311739	Double Knob (Lower)	PC-2028
8-21x	SK311740	Double Knob (Lower-BL)	PC-2028

II. MODEL PS-120M

1. RECOMMENDED SPARE PARTS LIST

Because, if the parts listed below are on hand, almost any repair can be accomplished, we suggest that you stock these Recommended Spare Parts Items.

Parts No.	Description	Note
BA311438	Filter P.C Board Comp. PS-120M	
BA311432	Main Amp P.C Board (L) Comp. PS-120M	
BA311436	Main Amp P.C Board (R) Comp. PS-120M	
BA311440	Meter P.C Board Comp. PS-120M	
BT311862	△ Power Trans. PS-120MT-30	(CSA)
BT311860	△ Power Trans. PS-120MT-40	(CEE, UK)
BT311859	△ Power Trans. PS-120MT-70	(U/T)
EC311688	Elect./C. 10000 μ F 71WV	
ED311794	LED SY405T	
ED311857	LED TLR114	
ED300924	Silicon Diode GP08D	
ED311849	Silicon Diode SS-3A	
ED311851	Silicon Diode SS-3AR	
ED311852	Silicon Diode 1S2471	
ED624903	Silicon Diode 1S2473	
ED490511	Varistor VD1222	
ED311854	Zener Diode RD-11E (C)	
ED311752	Zener Diode RD-22E (C)	
ED311864	Zener Diode RD-3.3E (C)	
ED311853	Zener Diode RD-6.2E (C)	
EF303348	△ Fuse ST-6 6.3A	(CSA)
EF308847	△ Fuse 1.6A 125V	(CSA)
EF311839	△ Fuse 1.6A 250V	(U/T)
EF305703	△ Fuse 630mA 125V	(CSA)
EF306124	△ Fuse 630mA 250V	(U/T)
EF300577	△ Fuse (EAK) 5AT	(CEE, UK)
EF623103	△ Fuse (SEMKO T) 1AT	(CEE, UK)
EF691007	△ Fuse (SEMKO T) 3.15AT	(U/T)
EF668474	△ Fuse (SEMKO T) 400mA T	(CEE, UK)
EF242605	△ Fuse (SEMKO T) 6.3AT	(U/T)
EI311855	IC LB1405	
EI308865	IC TA7318P	
EL311833	Lamp (Cord Type) 8V 300mA (200mmx2)	
EM311863	Meter KL-65L-100	
EP311858	Relay MSJ48D2-0Z	
ES311805	△ Lever SW. SY02-2 (U85DMU, C)	(U/T, CSA)
ES311806	△ Lever SW. V85DV	(CEE, UK)
ES311690	Push SW. J-K2014	
ET302465	FET 2SK117 (SPECIAL)	
ET311792	FET 2SK150 (GR) (Y)	
ET557965	Transistor 2SA733 (Q) (R)	

When ordering parts, please describe Parts Number, Description, and Model Number in detail.

Parts No.	Description	Note
ET311845	Transistor 2SA899 (B) (V)	
ET311844	Transistor 2SA949 (O) (Y) AKAI	
ET311791	Transistor 2SA968 (O) (Y)	
ET305463	Transistor 2SA970 (GR) (BL)	
ET311847	Transistor 2SB681 (O) (R) AKAI	
ET311865	Transistor 2SC1904 (B) (V)	
ET312485	Transistor 2SC2229 (O) (Y) AKAI	
ET311790	Transistor 2SC2238 (O) (Y)	
ET307195	Transistor 2SC2240 (GR) (BL)	
ET635220	Transistor 2SC945L (K) (P)	
ET311846	Transistor 2SD551 (O) (R) AKAI	
ET300931	Transistor 2SD600K (E) (F)	
EV310077	Semi-Fixed/Vol. (Solid) CR29R 1KB	
EV311836	Semi-Fixed/Vol. (Solid) CR29R 10KB	
EV311838	Semi-Fixed/Vol. (Solid) CR29R 220 ohms (B)	
EV311834	Vol. V24L52PHN25KC 100KB	
EV311835	Semi-Fixed/Vol. (Solid) CR29R 2.2KB	

2. MAIN AMP P.C BOARD (L) (PM-1201/1201S) BLOCK

Symbol No.	Parts No.	Description	Schematic No.	Symbol No.	Parts No.	Description	Schematic No.
2-1	BA311432	Main Amp P.C Board(L) Comp. PS-120M	PM-1201	2-R21	ER311668	Carbon/R. F 1/4W 1.8K (J)	35-11-25
2-TR1,2	ET302465	FET 2SK117(SPECIAL)	45-12-16	2-R22	ER311664	Carbon/R. F 1/4W 270 ohms (J)	35-11-25
2-TR3	ET311792	FET 2SK150(GR)(Y)	45-12-32	2-R23	ER311668	Carbon/R. F 1/4W 1.8K (J)	35-11-25
2-TR4to7	ET307195	Transistor 2SC2240(GR)(BL)	45-1-302	2-R25	ER311668	Carbon/R. F 1/4W 1.8K (J)	35-11-25
2-TR8,9	ET305463	Transistor 2SA970(GR)(BL)	45-1-303	2-R27	ER311667	Carbon/R. F 1/4W 1K (J)	35-11-25
2-TR10	ET311845	Transistor 2SA899(B)(V)	45-1-341	2-R28	ER311664	Carbon/R. F 1/4W 270 ohms (J)	35-11-25
2-TR11	ET311865	Transistor 2SC1904(B)(V)	45-1-342	2-R29	ER307196	Carbon/R. F 1/4W 100 ohms (J)	35-11-25
2-TR13to15	ET635220	Transistor 2SC945L(K)(P)	45-1-45	2-R32,33	ER307196	Carbon/R. F 1/4W 100 ohms (J)	35-11-25
2-TR16,17	ET557965	Transistor 2SA733(Q)(R)	45-1-124	2-R35	ER311667	Carbon/R. F 1/4W 1K (J)	35-11-25
2-TR18	ET635220	Transistor 2SC945L(K)(P)	45-1-45	2-R37	ER311667	Carbon/R. F 1/4W 1K (J)	35-11-25
2-TR19	ET312485	Transistor 2SC2229(O)(Y) AKAI	45-1-348	2-R38,39	ER311683	Metal Oxide Film/R. 3W 3.3K (K)	35-15-9
2-TR20	ET311844	Transistor 2SA949(O)(Y) AKAI	45-1-340	2-R40,41	ER308849	Carbon/R. F 1/4W 220 ohms (J)	35-11-25
2-TR21	ET311790	Transistor 2SC2238(O)(Y)	45-1-339	2-R42,43	ER310843	Carbon/R. F 1/4W 680 ohms (J)	35-11-25
2-TR22	ET311791	Transistor 2SA968(O)(Y)	45-1-338	2-R47to50	ER311669	Carbon/R. F 1/4W 3.3K (J)	35-11-25
2-TR23	ET305463	Transistor 2SA970(GR)(BL)	45-1-303	2-R51,52	ER311662	Carbon/R. F 1/4W 22 ohms (J)	35-11-25
2-TR24,25	ET307195	Transistor 2SC2240(GR)(BL)	45-1-302	2-R53,54	ER310147	Carbon/R. F 1/4W 10 ohms (J)	35-11-25
2-TR26	ET305463	Transistor 2SA970(GR)(BL)	45-1-303	2-R55,56	ER311667	Carbon/R. F 1/4W 1K (J)	35-11-25
2-TR27	ET307195	Transistor 2SC2240(GR)(BL)	45-1-302	2-R57,58	ER439132	Metal Oxide Film/R. 2W 150 ohms (K)	35-15-8
2-TR28	ET305463	Transistor 2SA970(GR)(BL)	45-1-303	2-R59to62	ER622978	Metal Plate/R. MPC71F1 5W 0.47 ohms (K)	35-16-44
2-TR29	ET311790	Transistor 2SC2238(O)(Y)	45-1-339	2-R67,68	ER312486	Metal Oxide Film/R. 2W 4.7 ohms (K)	35-15-18
2-TR30	ET311791	Transistor 2SA968(O)(Y)	45-1-338	2-R69,70	ER380856	Metal Oxide Film/R. 2W 10 ohms (K)	35-15-8
2-D1,2	ED624903	Silicon Diode 1S2471	45-3-28	2-R71,72	ER311665	Carbon/R. F 1/4W 560 ohms (J)	35-11-25
2-D4to7	ED311852	Silicon Diode 1S2471	45-3-52	2-R73,76	ER311673	Metal Oxide Film/R. 2W 3.3K (K)	35-15-8
2-D8,9	ED624903	Silicon Diode 1S2471	45-3-28	2-R81,82	ER308875	Carbon/R. F 1/2W 10 ohms (J)	35-11-27
2-D10,11	ED311852	Silicon Diode 1S2471	45-3-52	2-R83,84	ER312487	Metal Oxide Film/R. 2W 2.2K (K)	35-15-8
2-D12to15	ED311864	Zener Diode RD-3.3E(C)	45-6-72	2-1	ZS463353	Tapping Screw, #2, 3x8 (BR) (Black)	
2-D16	ED311849	Silicon Diode SS-3A	45-2-87				
2-D17	ED311851	Silicon Diode SS-3AR	45-2-88				
2-D18to21	ED300924	Silicon Diode GP08D	45-2-88				
2-D23,24	ED311752	Zener Diode RD-22E(C)	45-6-72				
2-D25,26	ED490511	Varistor VD1222	45-10-7				
2-L1	EO551711	Phase Compensation Coil 2.2μH (±30%)	23-1-188				
2-VR1	EV311838	Semi-Fixed/Vol. (Solid) CR29R 220 ohms (B)	36-28-6				
2-VR2	EV310077	Semi-Fixed/Vol. (Solid) CR29R 1KB	36-28-6				
2-VR3,4	EV311836	Semi-Fixed/Vol. (Solid) CR29R 10KB	36-28-6				
2-P2	EJ311841	Micro Connector W-P1302	42-1-154				
2-P4	EJ311841	Micro Connector W-P1302	42-1-154				
2-P6	EJ207854	3P Plug, PC	42-1-96				
2-P8	EJ311843	Micro Connector W-P1305	42-1-154				
2-P9	EJ311841	Micro Connector W-P1302	42-1-154				
2-P11	EJ699355	6P Plug, PC	42-1-95				
2-P13	EJ699355	6P Plug, PC	42-1-95				
2-P15	EJ311840	2P Plug W-P3002	42-1-152				
2-P17	EJ207854	3P Plug, PC	42-1-96				
2-P21	EJ311841	Micro Connector W-P1303	42-1-154				
2-R1	ER311751	Metal Film/R. 1/4W 100 ohms (F)	35-17-12				
2-R2	ER311672	Metal Film/R. 1/4W 150K (F)	35-17-12				
2-R5,6	ER311757	Metal Film/R. 1/4W 4.7K (F)	35-17-12				
2-R7,8	ER311671	Metal Film/R. 1/4W 180 ohms (F)	35-17-12				
2-R9,10	ER312324	Metal Film/R. 1/4W 68 ohms (F)	35-17-12				
2-R16,17	ER311668	Carbon/R. F 1/4W 1.8K (J)	35-11-25				
2-R18,19	ER311665	Carbon/R. F 1/4W 68 ohms (J)	35-11-25				

When ordering parts, please describe Parts Number, Description, and Model Number in detail.

3. MAIN AMP P.C BOARD (R)
(PM-1202/1202S) BLOCK

Symbol No.	Parts No.	Description	Schematic No.
3-1	BA311436	Main Amp P.C Board (R) Comp. PS-120M	PM-1202
3-TR1,2	ET302465	FET 2SK117 (SPECIAL)	45-12-16
3-TR3	ET311792	FET 2SK150 (GR) (Y)	45-12-12
3-TR4to7	ET307195	Transistor 2SC2240 (GR) (BL)	45-1-302
3-TR8,9	ET305463	Transistor 2SA970 (GR) (BL)	45-1-303
3-TR10	ET311845	Transistor 2SA899(B)(V)	45-1-341
3-TR11	ET311865	Transistor 2SC1904(B)(V)	45-1-342
3-TR13to15	ET635220	Transistor 2SC945L(K)(P)	45-1-45
3-TR16,17	ET557965	Transistor 2SA733(Q)(R)	45-1-124
3-TR18	ET635220	Transistor 2SC945L(K)(P)	45-1-45
3-TR19	ET312485	Transistor 2SC2229(O)(Y) AKAI	45-1-349
3-TR20	ET311844	Transistor 2SA949(O)(Y) AKAI	45-1-340
3-TR21	ET311790	Transistor 2SC2238(O)(Y)	45-1-339
3-TR22	ET311791	Transistor 2SA968(O)(Y)	45-1-338
3-TR23	ET305463	Transistor 2SA970 (GR) (BL)	45-1-303
3-TR24,25	ET307195	Transistor 2SC2240 (GR) (BL)	45-1-302
3-TR26	ET305463	Transistor 2SA970 (GR) (BL)	45-1-303
3-TR27	ET307195	Transistor 2SC2240 (GR) (BL)	45-1-302
3-TR28	ET305463	Transistor 2SA970 (GR) (BL)	45-1-303
3-TR29	ET311790	Transistor 2SC2238(O)(Y)	45-1-339
3-TR30	ET311791	Transistor 2SA968(O)(Y)	45-1-338
3-TR31	ET557965	Transistor 2SA733(Q)(R)	45-1-124
3-TR32to34	ET635220	Transistor 2SC945L(K)(P)	45-1-45
3-TR35	ET300931	Transistor 2SD600K(E)(F)	45-1-278
3-TR36	ET307195	Transistor 2SC2240 (GR) (BL)	45-1-302
3-D1,2	ED624903	Silicon Diode 1S2473	45-3-28
3-D4to7	ED311852	Silicon Diode 1S2471	45-3-28
3-D8,9	ED624903	Silicon Diode 1S2473	45-3-28
3-D10,11	ED311852	Silicon Diode 1S2471	45-3-28
3-TR12to15	ED311864	Zener Diode RD-3.3E (C)	45-3-71
3-D16	ED311849	Silicon Diode SS-3A	45-3-87
3-D17	ED311851	Silicon Diode SS-3AR	45-3-88
3-D18to22	ED300924	Silicon Diode GP08D	45-3-68
3-D23,24	ED311752	Zener Diode RD-2.2E (C)	45-3-72
3-D25,26	ED490511	Varistor VD122	45-1-17
3-D29	ED311854	Zener Diode RD-1.1E (C)	45-3-73
3-L1	EO551711	Phase Compensation Coil 2.2uH (±30%)	25-1-143
3-VR1	EV311838	Semi-Fixed/Vol. (Solid) CR29R 220 ohms (B)	35-28-6
3-VR2	EV310077	Semi-Fixed/Vol. (Solid) CR29R 1KB	35-28-6
3-VR3,4	EV311836	Semi-Fixed/Vol. (Solid) CR29R 10KB	35-28-6
3-RL1	EP311858	Relay MSF48D2-0Z	47-1-38
3-P1	EJ311841	Micro Connector W-P1302	42-1-154
3-P3	EJ311841	Micro Connector W-P1302	42-1-154
3-P5	EJ207854	3P Plug, PC	42-1-96
3-P7	EJ311843	Micro Connector W-P1305	42-1-155
3-P10	EJ699355	6P Plug, PC	42-1-95
3-P12	EJ699355	6P Plug, PC	42-1-95
3-P14	EJ311840	2P Plug, W-P3002	42-1-152
3-P16	EJ207854	3P Plug, PC	42-1-96
3-P18,19	EJ311841	Micro Connector W-P1302	42-1-154
3-P20	EJ311842	Micro Connector W-P1303	42-1-154
3-C41	EC311689	NP/C, 330uF (M) 6.3WV	24-17-31
3-C44	EC662128	Solid Aluminum/C. (Vert.) 2.2uF (M) 25WV	24-19-2
3-R1	ER311751	Metal Film/R. 1/4W 100 ohms (F)	35-17-12
3-R2	ER311672	Metal Film/R. 1/4W 150K (F)	35-17-12

4. FILTER P.C BOARD
(PM-1203/1203S) BLOCK

Symbol No.	Parts No.	Description	Schematic No.
4-1	BA311438	Filter P.C Board Comp. PS-120M	PM-1203
4-TR1	ET307195	Transistor 2SC2240 (GR) (BL)	45-1-302
4-TR2,3	ET305463	Transistor 2SA970 (GR) (BL)	45-1-303
4-TR4	ET307195	Transistor 2SC2240 (GR) (BL)	45-1-302
4-VR1	EV311834	Vol. V24L52PHN25KC 100KB	35-2-44
4-SW1	ES311690	Push SW. J-K2014	25-2-12
4-C2	EC311779	NP/C, 2.2uF 50WV	24-17-31
4-2	ZS608477	Screw, Pan 3x4	
3-R5,6	ER311757	Metal Film/R. 1/4W 4.7K (F)	35-17-12
3-R7,8	ER311671	Metal Film/R. 1/4W 180 ohms (F)	35-17-12
3-R9,10	ER312324	Metal Film/R. 1/4W 68 ohms (F)	35-17-12
3-R16,17	ER311668	Carbon/R. F 1/4W 1.8K (J)	35-11-25
3-R18,19	ER311663	Carbon/R. F 1/4W 68 ohms (J)	35-11-25
3-R21	ER311668	Carbon/R. F 1/4W 1.8K (J)	35-11-25
3-R22	ER311664	Carbon/R. F 1/4W 270 ohms (J)	35-11-25
3-R23	ER311668	Carbon/R. F 1/4W 1.8K (J)	35-11-25
3-R25	ER311668	Carbon/R. F 1/4W 1.8K (J)	35-11-25
3-R27	ER311667	Carbon/R. F 1/4W 1K (J)	35-11-25
3-R28	ER311664	Carbon/R. F 1/4W 270 ohms (J)	35-11-25
3-R29	ER307196	Carbon/R. F 1/4W 100 ohms (J)	35-11-25
3-R32,33	ER307196	Carbon/R. F 1/4W 100 ohms (J)	35-11-25
3-R35	ER311667	Carbon/R. F 1/4W 1K (J)	35-11-25
3-R37	ER311667	Carbon/R. F 1/4W 1K (J)	35-11-25
3-R38,39	ER311683	Metal Oxide Film/R. 3W 3.3K (K)	35-15-9
3-R40,41	ER308849	Carbon/R. F 1/4W 220 ohms (J)	35-11-25
3-R42,43	ER310843	Carbon/R. F 1/4W 680 ohms (J)	35-11-25
3-R47to50	ER311669	Carbon/R. F 1/4W 3.3K (J)	35-11-25
3-R51,52	ER311662	Carbon/R. F 1/4W 22 ohms (J)	35-11-25
3-R53,54	ER310147	Carbon/R. F 1/4W 10 ohms (J)	35-11-25
3-R55,56	ER311667	Carbon/R. F 1/4W 1K (J)	35-11-25
3-R57,58	ER439132	Metal Oxide Film/R. 2W 150 ohms (K)	35-15-8
3-R59to62	ER622978	Metal Plate/R. MPC71F1 5W 0.47 ohms (K)	35-14-48
3-R67,68	ER312486	Metal Oxide Film/R. 2W 4.7 ohms (K)	35-15-18
3-R69,70	ER380856	Metal Oxide Film/R. 2W 10 ohms (K)	35-15-8
3-R71,72	ER311665	Carbon/R. F 1/4W 560 ohms (J)	35-11-25
3-R75,76	ER311673	Metal Oxide Film/R. 2W 3.3K (K)	35-15-9
3-R89	ER311662	Carbon/R. F 1/4W 22 ohms (J)	35-11-25
3-R95	ER309092	Metal Oxide Film/R. 2W 820 ohms (K)	35-15-8
3-R102,103	ER308875	Carbon/R. F 1/2W 10 ohms (J)	35-11-27
3-2	ZS463353	Tapping Screw, #2, 3x8 (BR) (Black)	

5. METER P.C BOARD
(PM-1204/1204S) BLOCK

Symbol No.	Parts No.	Description	Schematic No.
5-1	BA311440	Meter P.C Board Comp. PS-120M	PM-1204
5-IC1	EI308865	IC TA7318P	45-3-206
5-IC2	EI311855	IC LB1405	45-3-228
5-TR1	ET311791	Transistor 2SA968(O)(Y)	45-1-338
5-TR2	ET557965	Transistor 2SA733(Q)(R)	45-1-124
5-TR3,4	ET307195	Transistor 2SC2240 (GR) (BL)	45-1-302
5-D1,2	ED300924	Silicon Diode GP08D	45-3-68
5-D3	ED311853	Zener Diode RD-6.2E (C)	45-3-72
5-D4	ED624903	Silicon Diode 1S2473	45-3-28
5-VR1	EV310077	Semi-Fixed/Vol. (Solid) CR29R 1KB	35-28-6
5-VR2	EV311835	Semi-Fixed/Vol. (Solid) CR29R 2.2KB	35-28-6
5-RL2	ER312483	Metal Oxide Film/R. 2W 1.2K (K)	35-15-2
5-FR1	ER293635	Fuse/R. FRN158 1/4W 10 ohms (J) 700mA	35-14-20

When ordering parts, please describe Parts Number, Description, and Model Number in detail.

When ordering parts, please describe Parts Number, Description, and Model Number in detail.

6. ASSEMBLY BLOCK

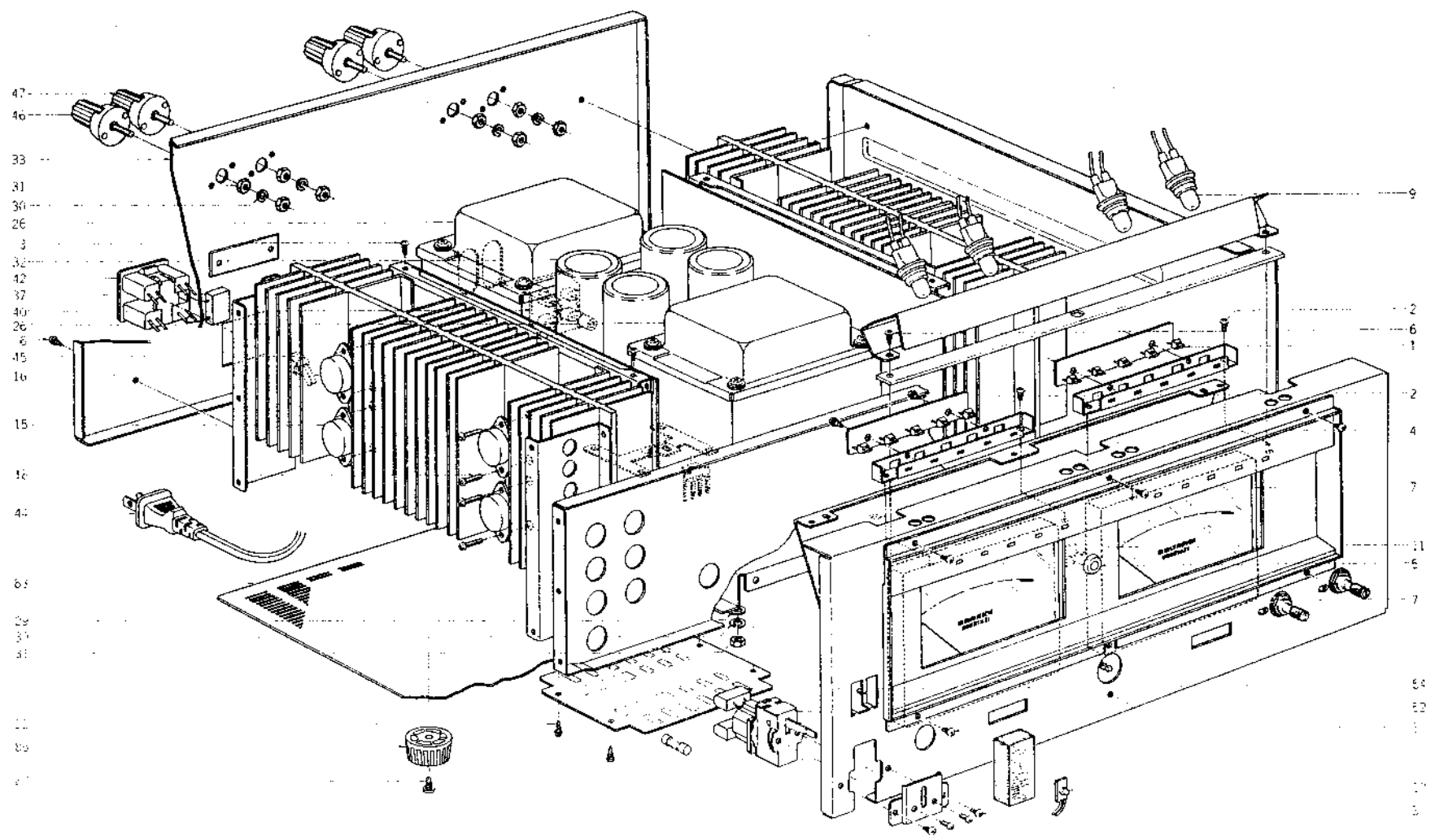

6. ASSEMBLY BLOCK

Ref. No.	Parts No.	Description	Schematic No.	Ref. No.	Parts No.	Description	Schematic No.
LED P.C BOARD (A) BLOCK							
6-1	ED311856	LED SLP137B	45-15-23	6-45	EZ631945	Strain Relief SR-4N-4	2-7-49
6-2	ZS447761	Tapping Screw, #2, 3x6 (BR) (Black)		6-46	EJ311695	Terminal T5689-A	12-1-99
FRONT CHASSIS BLOCK							
6-3	ZS308446	Tapping Screw, #2, 3x8 (BR) (Oval Neck)	1-1-89 PM-1216/1219	6-47	EJ311696	Terminal T5689-B	12-1-102
6-4	ML311629	Meter Plate	PM-1217	6-48x	EC308528	Oil Paper/C. ECN-C4A 0.047µF (M) 450WV (CEE, UK) Ceramic/C. AL-10 0.01µF (Z) 125WV (CSA)	24-2-6 24-3-89
6-5	MH311627	Collar		6-50x	ZS608477	Screw, Pan 3x4	46-2-23
6-6	ZS463353	Tapping Screw, #2, 3x8 (BR) (Black)		6-51x	ZS312349	Screw, Pan 4x8	
6-7	EM311863	Meter KL-65L-100	46-2-22	6-52	ES311805	Δ Lever SW. SY02-2 (U85DMU, C) (U/T, CSA)	25-12-48 25-12-50
6-8x	ZS355522	Screw, Pan 3x6 (Black)		6-53x	ES311806	Δ Lever SW. V85DV (CEE, UK)	25-12-50
6-9	EL311833	Lamp (Cord Type) 8V 300mA (200mmx2)	28-2-71	6-54	EC283375	Δ MP/C 0.047µF (M) 250WV (U/T)	24-9-118
LED P.C BOARD (B) BLOCK							
6-10	ED311794	LED SY405T (Power)	45-15-24	6-55x	EC308528	Δ Oil Paper/C. ECN-C4A 0.047µF (M) 450WV (CEE, UK) Ceramic/C. AL-10 0.01µF (Z) 125WV (CSA)	24-2-6 24-3-89
6-11	ED311857	LED TLR114 (Protection)	45-15-25	6-56x	EC286198	Δ Ceramic/C. AL-10 0.01µF (Z) 125WV (CSA)	24-3-15
6-12x	EJ313596	Micro Connector Assy C1205 (J18)	26-4-318	6-57x	EJ314568	Fuse Holder	39-1-53
TEMP. COMPENSATION P.C BOARD BLOCK							
6-13x	ET635220	Transistor 2SC945L(K)(P) (TR1)	45-1-85	6-58x	EF242605	Δ Fuse (SEMKO T) 6.3AT (UK)	39-1-53
6-14x	EJ313599	Micro Connector Assy C2208 (J20, 21)	26-6-229	6-59x	EF306124	Δ Fuse 630mA 250V (U/T)	39-1-54
HEAT SINK BLOCK							
6-15	ET311847	Transistor 2SB681 (O)(R) AKAI	45-1-24	6-60x	EF311839	Δ Fuse 1.6A 250V (U/T)	39-1-54
6-16	ET311846	Transistor 2SD551 (O)(R) AKAI	45-1-24	6-61x	EF691007	Δ Fuse (SEMKO T) 3.15AT (U/T)	39-1-51
6-17x	EJ624486	Power TR. Socket	31-1-97	6-62x	EF303348	Δ Fuse ST-6 6.3A (CSA)	39-1-53
6-18	ZS344338	Screw, Pan 3x12		6-63x	EF305703	Δ Fuse 630mA 125V (CSA)	39-1-55
6-19x	EJ313603	Mini Connector Assy C1103 (J10, 11)	26-6-225	6-64x	EF308847	Δ Fuse 1.6A 125V (CSA)	39-1-55
6-20x	EJ313604	Mini Connector Assy C1103 (J13)	26-6-227	6-65x	EF305777	Δ Fuse (EAK) 5AT (CEE, UK)	39-1-59
6-21x	EJ313604	Mini Connector Assy C2104 (J12)	26-6-226	6-66x	EF668474	Δ Fuse (SEMKO T) 400mAT (CEE, UK)	39-1-53
ASSEMBLY BLOCK							
6-22	ZS311745	Tapping Screw, #2, 3x8 (BR) W=8 (Black)		6-67x	EF623103	Δ Fuse (SEMKO T) 1AT (CEE, UK)	39-1-53
6-23x	ZW668621	M4 Spring Washer (Black)		6-68x	EJ313598	Micro Connector Assy C1207(J1)	26-6-229
6-24x	ZS608477	Screw, Pan 3x4		6-69x	EJ313597	Micro Connector Assy C1206(J2)	26-6-219
6-25x	ZS201778	Screw, Pan 4x8		6-70x	EJ313591	Micro Connector Assy C1201(J3)	26-6-214
6-26	BT311859	Δ Power Trans. PS-120MT-70 (U/T)	38-4-444	6-71x	EJ313592	Micro Connector Assy C1202(J4)	26-6-215
6-27x	BT311862	Δ Power Trans. PS-120MT-30 (CSA)	38-4-490	6-72x	EJ313602	Mini Connector Assy C1102(J5, 6)	26-6-224
6-28x	BT311860	Δ Power Trans. PS-120MT-40 (CEE, UK)	38-4-489	6-73x	EJ313600	Micro Connector Assy C1209(J7, B)	26-6-222
6-29	ZW237857	Washer D4.1x10x1T		6-74x	EJ313594	Micro Connector Assy C1203(J9)	26-6-216
6-30	ZW273914	Spring Washer, M4		6-75x	EJ313601	Mini Connector Assy C1101	26-6-222
6-31	ZW413188	Nut, #1, M4		6-76x	EJ313606	Mini Connector Assy C1106	26-6-228
6-32	EC311688	Elect./C. 10000µF 71WV	24-10-130	6-77x	EJ313595	Micro Connector Assy C1204	26-6-217
6-33	SP311640	Rear Panel (U-1) (U/T)	PM-1223	6-78x	EW313609	Wire (A) Assy (320mm)	26-1-9
6-34x	SP311641	Rear Panel (A-1) (CSA)	PM-1220	6-79x	EW313610	Wire (B) Assy (180mm)	26-1-10
6-35x	SP311642	Rear Panel (E-1) (CEE)	PM-1232	6-80x	EW313611	Wire (C) Assy (230mm)	26-1-11
6-36x	SP311643	Rear Panel (B-1) (UK)	PM-1233	6-81x	EW313612	Wire (D) Assy (280mm)	26-1-12
6-37	EC283375	Δ MP/C 0.047µF (M) 250WV (U/T)	24-9-118	6-82x	ZS311746	Tapping Screw, #2, 3x8 (Counterzunk) (Black)	PM-1234
6-38x	EC308528	Δ Oil Paper/C. ECN-C4A 0.047µF (M) 450WV (CEE, UK)	24-2-6	6-83	SP311644	Bottom Plate	
6-39x	EC286198	Δ Ceramic/C. AL-10 0.01µF (Z) 125WV (CSA)	24-3-89	6-84x	ZW668621	M4 Spring Washer (Black)	
6-40	EJ312482	4P Pin Jack	31-3-149	6-85x	ZS537006	Screw, Bind 4x8 (Black)	CA-6014
6-41x	ZS522865	Tapping Screw, #2, 3x12 (BR) (Black)		6-86	SA312465	Circular Foot (A) Part CA	
6-42	EZ225145	Δ 2-Throw AC Outlet (U/T, CSA)	31-1-166	6-87	ZS311747	Tapping Screw, #2, 4x8 (Pan) (Black)	24-9-118
6-43x	EJ296853	Δ 3P In-Let CM-3 (CEE, UK)	31-1-199	6-88x	EC283375	MP/C 0.047µF (M) 250WV (U/T)	
6-44	EW311816	Δ Power Cord 125V 13A (U/T, CSA)	24-3-75				

When ordering parts, please describe Parts Number, Description, and Model Number in detail.

7. FINAL ASSEMBLY BLOCK

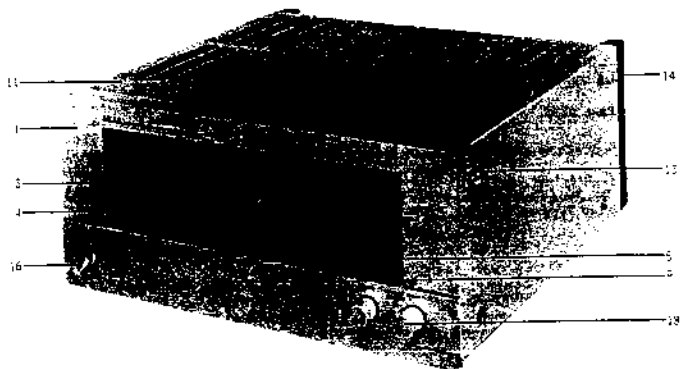

7. FINAL ASSEMBLY BLOCK

Ref. No.	Parts No.	Description	Schemaic No.
7-1	BD311414	Front Panel Block Comp. PS-120M	
7-2x	BD311415	Front Panel Block Comp. PS-120M-BL	
7-3	SZ311647	Front Plate	PM-1237
7-4	SE311728	Power Lens	PC-2071
7-5	SE311652	Button Escutcheon	PM-1240
7-6x	ZG311653	Spring	PM-1241
7-7x	SB311650	Button	PM-1239
7-8x	SB311651	Button (BL)	PM-1238
7-9	SH311648	Cap	PM-1238
7-10x	SH311649	Cap (BL)	PM-1238
7-11	BC311654	Case	PM-1242
7-12x	BC311649	Case (BL)	PM-1242
7-13	ZS437006	Screw, Bind 4x8 (Black)	
7-14	SA311655	Foot	PM-1243
7-15x	ZS411232	Screw, Bind 4x10	
7-16	ML311731	Lever (A)	PC-2024
7-17x	ML311732	Lever (A-BL)	PC-2024
7-18	SK311735	Knob	PC-2026
7-19x	SK311736	Knob (BL)	PC-2026

III. MODEL PS-200M

1. RECOMMENDED SPARE PARTS LIST

Because, if the parts listed below are on hand, almost any repair can be accomplished, we suggest that you stock these Recommended Spare Parts Items.

Parts No.	Description	Note
BA311438	Filter P.C Board Comp. PS-120M	
BA312154	Main Amp P.C Board (L) Comp. PS-200M	
BA312158	Main Amp P.C Board (R) Comp. PS-200M	
BA312162	Meter P.C Board Comp. PS-200M	
BT312422	△ Power Trans. PS-200MT-30	(CSA)
BT312424	△ Power Trans. PS-200MT-40	(CEE, UK)
BT312425	△ Power Trans. PS-200MT-70	(U/T)
EC312459	Elect./C. 10000μF 90WV	
ED311856	LED SLP137B	
ED311794	LED SY405T	
ED311857	LED TLR114	
ED300924	Silicon Diode GP08D	
ED312449	Silicon Diode SS-5A	
ED312450	Silicon Diode SS-5AR	
ED311852	Silicon Diode 1S2471	
ED624903	Silicon Diode 1S2473	
ED490511	Varistor VD1222	
ED313705	Zener Diode RD-20E (C)	
ED311752	Zener Diode RD-22E (C)	
ED311864	Zener Diode RD-3.3E (C)	
ED308467	Zener Diode RD-4.7E (C)	
ED311853	Zener Diode RD-6.2E (C)	
EF303348	△ Fuse ST-6 6.3A	(CSA)
EF308847	△ Fuse 1.6A 125V	(CSA)
EF311839	△ Fuse 1.6A 250V	(U/T)
EF309391	△ Fuse 800mA 125V	(CSA)
EF309388	△ Fuse 800mA 250V	(U/T)
EF300577	△ Fuse (EAK) SAT	(CEE, UK)
EF623103	△ Fuse (SEMKO T) 1AT	(CEE, UK)
EF593706	△ Fuse (SEMKO T) 500mAT	(CEE, UK)
EF242605	△ Fuse (SEMKO T) 6.3AT	(U/T)
EL311855	IC LB1405	(U/T)
EL308865	IC TA7318P	
EL311833	Lamp (Cord Type) 8V 300mA (200mmx2)	
EM312444	Meter KL-90G-100	
EP311858	Relay MSJ48D2-QZ	
ES311805	△ Lever SW. SY02-2 (U8SDMU, C)	SW901 (U/T, CSA)
ES311806	△ Lever SW. V85DV	SW901 (CEE, UK)
ES311690	Push SW. JK2014	
ET302465	FET 2SK117 (SPECIAL)	
ET311792	FET 2SK150 (GR) (Y)	

Parts No.	Description	Note
ET557965	Transistor 2SA733 (Q) (R)	
ET311845	Transistor 2SA899 (B) (V)	
ET311844	Transistor 2SA949 (O) (Y) AKAI	
ET311791	Transistor 2SA968 (O) (Y)	
ET305463	Transistor 2SA970 (GR) (BL)	
ET312447	Transistor 2SB645 (O) (R)	
ET311865	Transistor 2SC1904 (B) (V)	
ET312485	Transistor 2SC2229 (O) (Y) AKAI	
ET311790	Transistor 2SC2238 (O) (Y)	
ET307195	Transistor 2SC2240 (GR) (BL)	
ET635220	Transistor 2SC945L (K) (P)	
ET300931	Transistor 2SD600K (E) (F)	
ET312446	Transistor 2SD665 (O) (R)	
EV310077	Semi-Fixed/Vol. (Solid) CR29R 1KB	
EV311836	Semi-Fixed/Vol. (Solid) CR29R 10KB	
EV311835	Semi-Fixed/Vol. (Solid) CR29R 2.2KB	
EV311838	Semi-Fixed/Vol. (Solid) CR29R 220 ohms (B)	
EV311834	Vol. V24L52PHN25KC 100KB	

2. MAIN AMP P.C BOARD (L) (PM-1201/1201S) BLOCK

Symbol No.	Parts No.	Description	Schematic No.	Symbol No.	Parts No.	Description	Schematic No.
2-4	BA313154	Main Amp P.C Board (L) Comp. PS-200M	PM-1201	2-R18,19	ER311663	Carbon/R. F 1/4W 68 ohms (J)	35-11-25
2-TR1,2	ET302465	FET 2SK227 (SPECIAL)	45-12-16	2-R21	ER311668	Carbon/R. F 1/4W 1.8K(J)	35-11-25
2-TR3	ET311792	FET 2SK150(GR) (Y)	45-12-22	2-R22	ER311654	Carbon/R. F 1/4W 270 ohms (J)	35-11-25
2-TR4to7	ET307195	Transistor 2SC2240 (GR) (BL)	45-1-302	2-R24,25	ER311668	Carbon/R. F 1/4W 1.8K(J)	35-11-25
2-TR8,9	ET305463	Transistor 2SA970 (GR) (BL)	45-1-303	2-R27	ER311667	Carbon/R. F 1/4W 1K (J)	35-11-25
2-TR10	ET311845	Transistor 2SA899(B)(V)	45-1-341	2-R28	ER311664	Carbon/R. F 1/4W 270 ohms (J)	35-11-25
2-TR11	ET311865	Transistor 2SC1904(B)(V)	45-1-342	2-R29	ER307196	Carbon/R. F 1/4W 100 ohms (J)	35-11-25
2-TR13to15	ET635220	Transistor 2SC945L(K)(P)	45-1-85	2-R32,33	ER307196	Carbon/R. F 1/4W 100 ohms (J)	35-11-25
2-TR16,17	ET557965	Transistor 2SA733(Q)(R)	45-1-124	2-R35	ER311667	Carbon/R. F 1/4W 1K (J)	35-11-25
2-TR18	ET635220	Transistor 2SC945L(K)(P)	45-1-85	2-R37	ER311667	Carbon/R. F 1/4W 1K (J)	35-11-25
2-TR19	ET312485	Transistor 2SC2229(O)(Y) AKAI	45-1-349	2-R38,39	ER312453	Metal Oxide Film/R. 3W 4.7K (J)	35-15-9
2-TR20	ET311844	Transistor 2SA949(O)(Y) AKAI	45-1-340	2-R40,41	ER308849	Carbon/R. F 1/4W 220 ohms (J)	35-11-25
2-TR21	ET311790	Transistor 2SC2238(O)(Y)	45-1-339	2-R42,43	ER310843	Carbon/R. F 1/4W 680 ohms (J)	35-11-25
2-TR22	ET311791	Transistor 2SA968(O)(Y)	45-1-338	2-R47to50	ER311669	Carbon/R. F 1/4W 3.3K (J)	35-11-25
2-TR23	ET305463	Transistor 2SA970 (GR) (BL)	45-1-303	2-R51	ER308849	Carbon/R. F 1/4W 220 ohms (J)	35-11-25
2-TR24,25	ET307195	Transistor 2SC2240 (GR) (BL)	45-1-302	2-R52	ER307196	Carbon/R. F 1/4W 100 ohms (J)	35-11-25
2-TR26	ET305463	Transistor 2SA970 (GR) (BL)	45-1-303	2-R53,54	ER675112	Carbon/R. F 1/2W 6.8 ohms (J)	35-11-13
2-TR27	ET307195	Transistor 2SC2240 (GR) (BL)	45-1-302	2-R55,56	ER311667	Carbon/R. F 1/4W 1K (J)	35-11-25
2-TR28	ET305463	Transistor 2SA970 (GR) (BL)	45-1-303	2-R57,58	ER439132	Metal Oxide Film/R. 2W 150 ohms (K)	35-15-8
2-TR29	ET311790	Transistor 2SC2238(O)(Y)	45-1-339	2-R59to66	ER312414	Metal Plate/R. MPC71 F1 5W 1 ohm (K)	35-15-48
2-TR30	ET311791	Transistor 2SA968(O)(Y)	45-1-338	2-R67,68	ER312486	Metal Oxide Film/R. 2W 4.7 ohms (K)	35-15-18
2-D1,2	ED624903	Silicon Diode 1S2473	45-3-28	2-R69,70	ER380856	Metal Oxide Film/R. 2W 10 ohms (K)	35-15-8
2-D3	ED311864	Zener Diode RD-3.3E(C)	45-6-72	2-R71,72	ER311665	Carbon/R. F 1/4W 560 ohms (J)	35-11-25
2-D4to7	ED311852	Silicon Diode 1S2471	45-3-32	2-R75,76	ER312451	Metal Oxide Film/R. 2W 4.7K (J)	35-15-8
2-D8,9	ED624903	Silicon Diode 1S2473	45-3-28	2-R81,82	ER308875	Carbon/R. F 1/2W 10 ohms (J)	35-11-27
2-D10,11	ED311852	Silicon Diode 1S2471	45-3-32	2-R83,84	ER313702	Metal Oxide Film/R. 2W 3.3K (J)	35-15-8
2-D12to15	ED311864	Zener Diode RD-3.3E(C)	45-6-72	2-2	2S463353	Tapping Screw, #2, 3x8 (BR) (Black)	
2-D16	ED312449	Silicon Diode SS-5A	45-2-89				
2-D17	ED312450	Silicon Diode SS-5AR	45-2-90				
2-D18to21	ED300924	Silicon Diode GP08D	45-2-68				
2-D23,24	ED311752	Zener Diode RD-12E(C)	45-6-72				
2-D25to28	ED490511	Varistor VD1222	45-10-7				
2-D29	ED308467	Zener Diode RD-4.7E(C)	45-6-72				
2-L1	EO551711	Phase Compensation CoB 2.2uH (+30%)	35-1-188				
2-VR1	EV311838	Semi-Fixed/Vol. (Solid) CR29R 220 ohms (B)	35-25-6				
2-VR2	EV310077	Semi-Fixed/Vol. (Solid) CR29R 1KB	35-25-6				
2-VR3,4	EV311836	Semi-Fixed/Vol. (Solid) CR29R 10KB	35-25-6				
2-P2	EJ311841	Micro Connector W-P1302	42-1-154				
2-P4	EJ311841	Micro Connector W-P1302	42-1-154				
2-P6	EJ207854	3P Plug, PC	42-1-96				
2-P8	EJ311843	Micro Connector W-P1305	42-1-154				
2-P9	EJ311841	Micro Connector W-P1302	42-1-154				
2-P11	EJ699353	6P Plug, PC	42-1-95				
2-P13	EJ699353	6P Plug, PC	42-1-95				
2-P15	EJ311840	2P Plug, W-P3002	42-1-152				
2-P17	EJ207854	3P Plug, PC	42-1-96				
2-P21	EJ311842	Micro Connector W-P1303	42-1-154				
2-R1	ER311751	Metal Film/R. 1/4W 100 ohms (F)	35-17-12				
2-R2	ER311672	Metal Film/R. 1/4W 150K (F)	35-17-12				
2-R5,6	ER311757	Metal Film/R. 1/4W 4.7K (F)	35-17-12				
2-R7,8	ER311671	Metal Film/R. 1/4W 180 ohms (F)	35-17-12				
2-R9,10	ER312324	Metal Film/R. 1/4W 68 ohms (F)	35-17-12				
2-R16,17	ER311668	Carbon/R. F 1/4W 1.8K(J)	35-11-25				

When ordering parts, please describe Parts Number, Description, and Model Number in detail.

3. MAIN AMP P.C BOARD (R)
(PM-1202/1202S) BLOCK

Symbol No.	Parts No.	Description	Schematic No.
3-1	BA312158	Main Amp P.C Board (R) Comp. FS-200M	PM-1202
3-TR1,2	ET302465	FET 2SK117 (SPECIAL)	45-12-16
3-TR3	ET311792	FET 2SK150 (GR) (Y)	45-12-22
3-TR4to7	ET307195	Transistor 2SC2240 (GR) (BL)	45-1-302
3-TR6,9	ET305463	Transistor 2SA970 (GR) (BL)	45-1-300
3-TR10	ET311845	Transistor 2SA899(B)(V)	45-1-341
3-TR11	ET311865	Transistor 2SC1904(B)(V)	45-1-342
3-TR13to15	ET635220	Transistor 2SC945L(K)(F)	45-1-85
3-TR16,17	ET557965	Transistor 2SA733(Q)(R)	45-1-124
3-TR18	ET635220	Transistor 2SC945L(K)(F)	45-1-85
3-TR19	ET312485	Transistor 2SC2229(O)(Y) AKAI	45-1-349
3-TR20	ET311844	Transistor 2SA949(O)(Y) AKAI	45-1-340
3-TR21	ET311790	Transistor 2SC2238(O)(Y)	45-1-339
3-TR22	ET311791	Transistor 2SA968(O)(Y)	45-1-338
3-TR23	ET305463	Transistor 2SA970 (GR) (BL)	45-1-300
3-TR24,25	ET307195	Transistor 2SC2240 (GR) (BL)	45-1-302
3-TR26	ET305463	Transistor 2SA970 (GR) (BL)	45-1-300
3-TR27	ET307195	Transistor 2SC2240 (GR) (BL)	45-1-302
3-TR28	ET305463	Transistor 2SA970 (GR) (BL)	45-1-300
3-TR29	ET311790	Transistor 2SC2238(O)(Y)	45-1-339
3-TR30	ET311791	Transistor 2SA968(O)(Y)	45-1-338
3-TR31	ET557965	Transistor 2SA733(Q)(R)	45-1-124
3-TR32to34	ET635220	Transistor 2SC945L(K)(F)	45-1-85
3-TR35	ET300931	Transistor 2SD600K(E)(F)	45-1-278
3-TR36	ET307195	Transistor 2SC2240 (GR) (BL)	45-1-302
3-D1,2	ED624903	Silicon Diode 1S2473	45-6-72
3-D3	ED311864	Zener Diode RD-3.3E (C)	45-6-72
3-D4to7	ED311852	Silicon Diode 1S2471	45-6-72
3-D8,9	ED624903	Silicon Diode 1S2473	45-6-72
3-D10,11	ED311852	Silicon Diode 1S2471	45-6-72
3-D12to15	ED311864	Zener Diode RD-3.3E (C)	45-6-72
3-D16	ED312449	Silicon Diode SS-5A	45-2-89
3-D17	ED312450	Silicon Diode SS-5AR	45-2-89
3-D18to22	ED300924	Silicon Diode GP08D	45-2-88
3-D23,24	ED311752	Zener Diode RD-22E (C)	45-6-72
3-D25to28	ED490511	Varistor VD1222	45-10-7
3-D29	ED313705	Zener Diode RD-20E (C)	45-6-72
3-D30	ED308467	Zener Diode RD-4.7E (C)	45-6-72
3-L1	EO551711	Phase Compensation Coil 2.2uH (±30%)	23-1-100
3-VR1	EV311838	Semi-Fixed/Vol. (Solid) CR29R 220 ohms (B)	35-28-6
3-VR2	EV310077	Semi-Fixed/Vol. (Solid) CR29R 1KB	35-28-6
3-VR3,4	EV311836	Semi-Fixed/Vol. (Solid) CR29R 10KB	35-28-6
3-RL1	EP311858	Relay MSJ48D2-02	42-1-154
3-P1	EJ311841	Micro Connector W-P1302	42-1-154
3-P3	EJ311841	Micro Connector W-P1302	42-1-154
3-P5	EJ207854	3P Plug, PC	42-1-96
3-P7	EJ311843	Micro Connector W-P1305	42-1-154
3-P10	EJ699355	6P Plug, PC	42-1-95
3-P12	EJ699355	6P Plug, PC	42-1-95
3-P14	EJ311840	2P Plug, W-P3002	42-1-152
3-P16	EJ207854	3P Plug, PC	42-1-96
3-P18,19	EJ311841	Micro Connector W-P1302	42-1-154
3-P20	EJ311842	Micro Connector W-P1303	42-1-154
3-C41	EC311689	NP/C, 330uF (M) 6.3WV	24-17-31
3-C44	EC662128	Solid Aluminum/C. (Vert.) 2.2uF (M) 25WV	24-19-2
3-R1	ER311751	Metal Film/R. 1/4W 100 ohms (F)	35-12-12

4. FILTER P.C BOARD
(PM-1203/1203S) BLOCK

Symbol No.	Parts No.	Description	Schematic No.
3-R2	ER311672	Metal Film/R. 1/4W 150K (F)	35-12-12
3-R5,6	ER311757	Metal Film/R. 1/4W 4.7K (F)	35-12-12
3-R7,8	ER311671	Metal Film/R. 1/4W 100 ohms (F)	35-12-12
3-R9,10	ER312324	Metal Film/R. 1/4W 68 ohms (F)	35-12-12
3-R16,17	ER311668	Carbon/R. F 1/4W 1.8K (J)	35-11-25
3-R18,19	ER311663	Carbon/R. F 1/4W 68 ohms (J)	35-11-25
3-R21	ER311668	Carbon/R. F 1/4W 1.8K (J)	35-11-25
3-R22	ER311664	Carbon/R. F 1/4W 270 ohms (J)	35-11-25
3-R24,25	ER311668	Carbon/R. F 1/4W 1.8K (J)	35-11-25
3-R27	ER311667	Carbon/R. F 1/4W 1K (J)	35-11-25
3-R28	ER311664	Carbon/R. F 1/4W 270 ohms (J)	35-11-25
3-R29	ER307196	Carbon/R. F 1/4W 100 ohms (J)	35-11-25
3-R32,33	ER307196	Carbon/R. F 1/4W 100 ohms (J)	35-11-25
3-R35	ER311667	Carbon/R. F 1/4W 1K (J)	35-11-25
3-R37	ER311667	Carbon/R. F 1/4W 1K (J)	35-11-25
3-R38,39	ER312453	Metal Oxide Film/R. 3W 4.7K (J)	35-15-9
3-R40,41	ER308849	Carbon/R. F 1/4W 220 ohms (J)	35-11-25
3-R42,43	ER310843	Carbon/R. F 1/4W 680 ohms (J)	35-11-25
3-R47to50	ER311669	Carbon/R. F 1/4W 3.3K (J)	35-11-25
3-R51	ER308849	Carbon/R. F 1/4W 220 ohms (J)	35-11-25
3-R52	ER307196	Carbon/R. F 1/4W 100 ohms (J)	35-11-25
3-R53,54	ER675112	Carbon/R. F 1/2W 6.8 ohms (J)	35-11-13
3-R55,56	ER311667	Carbon/R. F 1/4W 1K (J)	35-11-25
3-R57,58	ER439132	Metal Oxide Film/R. 2W 150 ohms (K)	35-15-8
3-R59to66	ER312414	Metal Plate/R. MPC71F1 5W 1 ohm (K)	35-16-48
3-R67,68	ER312486	Metal Oxide Film/R. 2W 4.7 ohms (K)	35-15-18
3-R69,70	ER380856	Metal Oxide Film/R. 2W 10 ohms (K)	35-15-8
3-R71,72	ER311665	Carbon/R. F 1/4W 560 ohms (J)	35-11-25
3-R75,76	ER312451	Metal Oxide Film/R. 2W 4.7K (J)	35-15-8
3-R89	ER311662	Carbon/R. F 1/4W 22 ohms (J)	35-11-25
3-R95	ER313798	Metal Oxide Film/R. 2W 1.5K (J)	35-15-8
3-R102,103	ER308875	Carbon/R. F 1/2W 10 ohms (J)	35-11-27
3-2	ZS463353	Tapping Screw, #2, 3x8 (BR) (Black)	

5. METER P.C BOARD
(PM-2001/2001S) BLOCK

Symbol No.	Parts No.	Description	Schematic No.
5-1	BA312162	Meter P.C Board Comp. PS-200M	PM-2001
5-IC1	EI308865	IC TA731 8P	45-9-106
5-IC2,3	EI311855	IC LB1405	45-9-128
5-TR1	ET311791	Transistor 2SA968(O)(Y)	45-1-338
5-TR2	ET557965	Transistor 2SA733(Q)(R)	45-1-124
5-TR3,4	ET307195	Transistor 2SC2240 (GR) (BL)	45-1-302
5-D1,2	ED300924	Silicon Diode GP08D	45-2-88
5-D3	ED311853	Zener Diode RD-4.2E(C)	45-6-72
5-D4	ED624903	Silicon Diode 1S2473	45-6-72
5-VR1	EV310077	Semi-Fixed/Vol. (Solid) CR29R 1KB	35-28-6
5-VR2	EV311835	Semi-Fixed/Vol. (Solid) CR29R 2.2KB	35-28-6
5-R1,2	ER453565	Metal Oxide Film/R. 2W 1.2K (J)	35-15-8
5-FR1	ER293635	Fuse/R. FRN158 1/4W 10 ohms (J) 700 mA	35-14-20

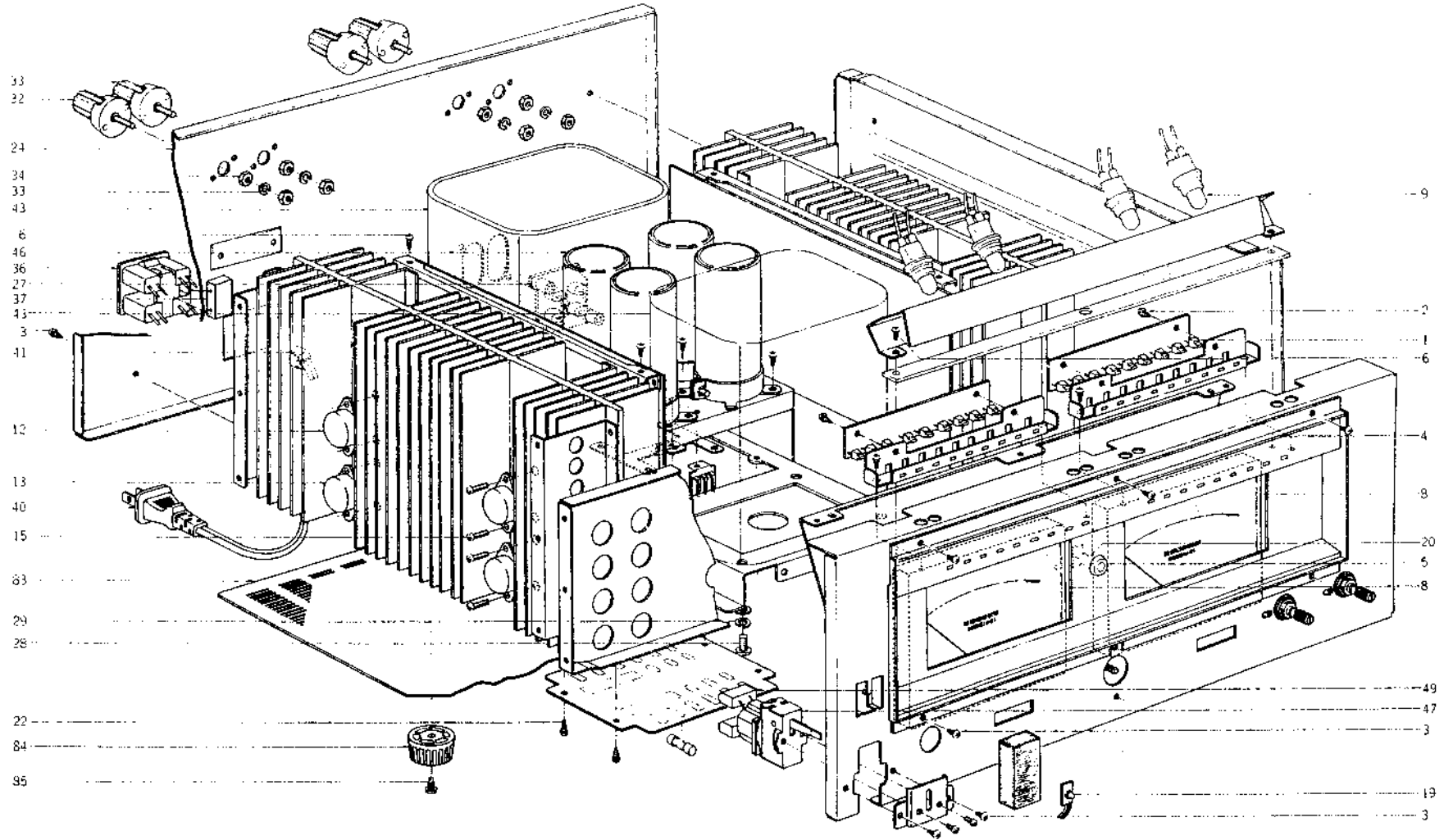

6. ASSEMBLY BLOCK

6. ASSEMBLY BLOCK

Ref. No.	Parts No.	Description	Schematic No.
LED P.C BOARD (C) BLOCK			
6-1	ED311856	LED SLP137B	45-15-23
6-2	ZS447761	Tapping Screw, #2, 3x6 (BR) (Black)	
FRONT CHASSIS BLOCK			
6-3	ZS308846	Tapping Screw, #2, 3x8 (BR) (Oval Neck)	7-1-69
6-4	ML312430	Meter Plate	PM-2004/2007
6-5	MH311627	Collar	PM-1217
6-6	ZS463353	Tapping Screw, #2, 3x8 (BR) (Black)	
6-7x	ZS355522	Screw, Pan 3x6 (Black)	
6-8	EM312444	Meter KL-90G-100	45-2-24
6-9	EL311833	Lamp (Cord Type) 8V 300mA (200mmx2)	28-2-71
TEMP. COMPENSATION P.C BOARD BLOCK			
6-10x	ET635220	Transistor 2SC945L(K)(P) (TR1)	45-1-85
6-11x	EJ313607	Micro Connector Assy C2208 (J20, 21)	26-4-320
HEAT SINK BLOCK			
6-12	ET312446	Transistor 2SD665 (O) (R)	45-1-345
6-13	ET312447	Transistor 2SB645 (O) (R)	45-1-346
6-14x	E1624486	Power TR. Socket	31-1-87
6-15	ZS608501	Screw, Pan 3x12	
6-16x	EJ313603	Mini Connector Assy C1103 (J10, 11)	26-4-325
6-17x	EJ313605	Mini Connector Assy C1105 (J13)	26-4-327
6-18x	EJ313604	Mini Connector Assy C1104 (J12)	26-4-326
LED P.C BOARD (B) BLOCK			
6-19	ED311794	LED SY405T (Power)	45-15-24
6-20	ED311857	LED TLR114 (Protection)	45-15-25
6-21x	EJ313596	Micro Connector Assy C1205 (J18)	26-4-318
6-22	ZS311745	Tapping Screw, #2, 3x8 (BR) W=8 (Black)	
6-23x	ZS608477	Screw, Pan 3x4	
6-24	SP312437	Rear Panel (U-2) (U/T)	PM-2010
6-25x	SP312438	Rear Panel (C, A-2) (CSA)	PM-2011
6-26x	SP312439	Rear Panel (E-2) (CEE)	PM-2013
6-27x	SP312440	Rear Panel (B-2) (UK)	PM-2014
6-28	ZS201778	Screw, Pan 4x8	
6-29	ZW668621	M4 Spring Washer (Black)	
6-30	EJ312482	4P Pin Jack	31-5-140
6-31x	ZS522865	Tapping Screw, #2, 3x12 (BR) (Black)	
6-32	EJ311695	Terminal T5689-A	32-1-99
6-33	EJ311696	Terminal T5689-B	32-1-102
6-34	ZW273914	Spring Washer, M4	
6-35	ZW413188	Nut, M4 #1	
6-36	EZ225145	Δ 2-Throw AC Outlet (U/T, CSA)	31-1-166
6-37	EC283375	Δ MP/C, 0.047μF (M) 250WV (U/T)	24-9-118
6-38x	EC286198	Δ Ceramic/C, AL-10 0.01μF (Z) 125WV (CSA)	24-5-69
6-39x	EC308528	Δ Oil Paper/C, ECN-C4A 0.047μF (M) 450WV (CEE, UK)	24-4-6
6-40	EW311816	Δ Power Cord 125V 13A (U/T, CSA)	26-3-75
6-41	EZ631945	Strain Relief SR-4N-4 (U/T, CSA)	2-1-49
6-42x	EJ296853	Δ 3P In-Let CM-3 (CEE, UK)	31-1-199
6-43	BT312425	Δ Power Trans. PS-200MT-70 (U/T)	38-4-69x
6-44x	BT312422	Δ Power Trans. PS-200MT-30 (CSA)	38-4-69z
6-45x	BT312424	Δ Power Trans. PS-200MT-40 (CEE, UK)	38-4-69z

Ref. No.	Parts No.	Description	Schematic No.
6-46	EC312459	Elect./C, 10000μF 90WV	24-10-131
6-47	ES311805	Δ Lever SW. SY02-2 (U85DMU, C) (U/T, CSA)	25-12-48
6-48x	ES311806	Δ Lever SW. V85DV (CEE, UK)	25-12-50
6-49	EC283375	Δ MP/C, 0.047μF (M) 250WV (U/T)	24-9-118
6-50x	EC286198	Δ Ceramic/C, AL-10 0.01μF (Z) 125WV (CSA)	24-5-69
6-51x	EC308528	Δ Oil Paper/C, ECN-C4A 0.047μF (M) 450WV (CEE, UK)	24-4-6
6-52x	EJ314568	Fuse Holder (UK)	46-1-5
6-53x	EF242605	Δ Fuse (SEMKO T) 6.3AT (UK)	38-1-5
6-54x	EC286198	Ceramic/C, AL-10 0.01μF (Z) 125WV (CSA)	24-5-69
6-55x	EC308528	Oil Paper/C, ECN-C4A 0.047μF (M) 450WV (CEE, UK)	24-4-6
6-56x	EJ313598	Micro Connector Assy C1207 (J1)	26-4-320
6-57x	EJ313597	Micro Connector Assy C1206 (J2)	26-4-319
6-58x	EJ313591	Micro Connector Assy C1201 (J3)	26-4-314
6-59x	EJ313592	Micro Connector Assy C1202 (J4)	26-4-315
6-60x	EJ313602	Mini Connector Assy C1102 (J5, 6)	26-4-324
6-61x	EJ313600	Micro Connector Assy C1209 (J7, 8)	26-4-322
6-62x	EJ313594	Micro Connector Assy C1203 (J9)	26-4-316
6-63x	EJ313601	Mini Connector Assy C1101 (J14, 15)	26-4-323
6-64x	EJ313606	Mini Connector Assy C1106 (J16, 17)	26-4-328
6-65x	EJ313595	Micro Connector Assy C1204 (J19)	26-4-317
6-66x	EW313609	Wire (A) Assy (320mm)	26-1-9
6-67x	EW313610	Wire (B) Assy (180mm)	26-1-10
6-68x	EW313611	Wire (C) Assy (230mm)	26-1-11
6-69x	EW313613	Wire (E) Assy (230mm)	26-1-13
6-70x	EF309388	Δ Fuse 800mA 250V (U/T)	39-1-64
6-71x	EF311839	Δ Fuse 1.6A 250V (U/T)	39-1-64
6-72x	EF242605	Δ Fuse (SEMKO T) 6.3AT (U/T)	38-1-53
6-73x	EF303348	Δ Fuse ST-6 6.3A (CSA)	39-1-63
6-74x	EF309391	Δ Fuse 800mA 125V (CSA)	39-1-65
6-75x	EF308847	Δ Fuse 1.6A 125V (CSA)	39-1-65
6-76x	EF303348	Δ Fuse ST-6 6.3A (CSA)	39-1-63
6-77x	EF309391	Δ Fuse 800mA 125V (CSA)	39-1-65
6-78x	EF308847	Δ Fuse 1.6A 125V (CSA)	39-1-65
6-79x	EF300577	Δ Fuse (EAK) 5AT (CEE, UK)	39-1-59
6-80x	EF593706	Δ Fuse (SEMKO T) 500mA (CEE, UK)	39-1-53
6-81x	EF623103	Δ Fuse (SEMKO T) 1AT (CEE, UK)	39-1-53
6-82x	ZS311746	Tapping Screw, #2, 3x8 (Countersunk) (Black)	
6-83	SP311644	Bottom Plate	PM-1234
6-84	SA312465	Circular Foot (A) Part CA	CA-8014
6-85	ZS311747	Tapping Screw, #2, 4x8 (Pan) (Black)	
6-86x	EC283375	MP/C, 0.047μF (M) 250WV (U/T)	24-9-118

7. FINAL ASSEMBLY BLOCK

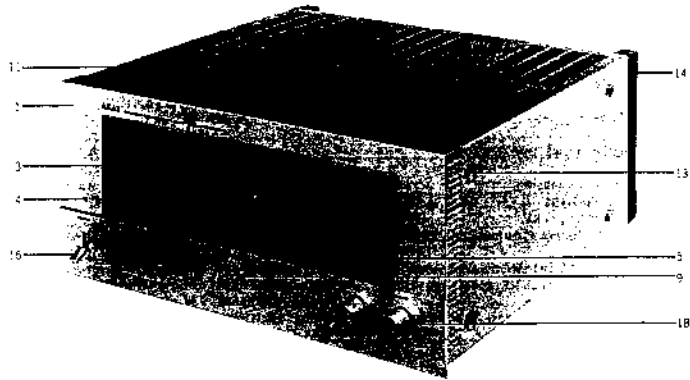

7. FINAL ASSEMBLY BLOCK

Ref. No.	Parts No.	Description	Schematic No.
7-1	BD312146	Front Panel Block Comp.	
		PS-200M	
7-2x	BD312147	Front Panel Block Comp.	
		PS-200M-BL	
7-3	SZ311647	Front Plate	PM-1237
7-4	SE311718	Power Lens	PC-2021
7-5	SE311652	Button Escutcheon	PM-1240
7-6x	ZG311653	Spring	PM-1241
7-7x	SB311650	Button	PM-1239
7-8x	SB311651	Button (BL)	PM-1239
7-9	SH311648	Cap	PM-1238
7-10x	SH311649	Cap (BL)	PM-1238
7-11	BC311654	Case	PM-1242
7-12x	BC312479	Case (BL)	PM-1242
7-13	ZS537006	Screw, Blind 4x8 (Black)	
7-14	SA311655	Foot	PM-1243
7-15x	ZS608635	Screw, Pan 4x10	
7-16	ML311731	Lever (A)	PC-2024
7-17x	ML311732	Lever (A-BL)	PC-2024
7-18	SK311735	Knob	PC-2025
7-19x	SK311736	Knob (BL)	PC-2025

Parts No.	Ref. No. & Symbol No.	Parts No.	Ref. No. & Symbol No.	Parts No.	Ref. No. & Symbol No.	Parts No.	Ref. No. & Symbol No.
BA311370	3-1	ER311764	2-R83	SK311739	8-20		
BA313970	2-1	ER311765	2-R84	SK311740	8-21x		
BC311730	8-9	ER311766	2-R85	SP311718	7-22		
BC312352	8-10x	ER311767	2-R86	SP311719	7-23x		
BD313972	8-1x	ER311768	2-R87	SP311720	7-24x		
BD313973	8-2x	ER311772	2-R31	SP311721	7-25x		
BT311809	7-4x	ER311773	2-R63	SP311722	7-52		
BT311810	7-5x	ER311774	4-R1	TA311726	8-3		
BT311811	7-3	ER311774	5-R1	TA311727	8-4x		
EC283375	7-13	ER311775	5-R2	TA646773	7-19		
EC283375	7-38	ER311875	2-R28,29	ZG312478	8-8x		
EC286198	7-14x	ER311876	4-R7	ZS201778	7-9x		
EC286198	7-36x	ER312460	3-R7	ZS308846	7-1		
EC301320	7-15x	ER312461	2-R5,6	ZS311743	7-17x		
EC301320	7-35x	ER483287	3-R29	ZS311746	7-51x		
EC301320	7-37x	ES246227	5-SW1	ZS311747	7-54		
EC311778	2-C49	ES311797	2-SW3	ZS411232	8-13x		
EC311780	2-C8	ES311797	3-SW1	ZS421740	2-2		
EC311780	2-C23	ES311798	2-SW1	ZS421740	3-2		
EC311780	2-C32	ES311799	2-SW2	ZS463353	7-34x		
EC311780	2-C50	ES311802	4-SW1	ZSS22865	7-30x		
EC311780	2-C51	ES311803	4-SW2	ZSS37006	7-6		
EC311780	4-C5	ES315601	2-SW3	ZSS37006	8-11		
EC311781	2-C30	ES664222	7-11	ZS608185	7-31		
EC311782	2-C35	ES665807	7-12x	ZS608477	7-2		
EC311786	2-C19	ET300931	1-TR17	ZW270123	7-21		
EC311787	2-C18	ET300931	3-TR9	ZW273914	7-8		
EC311788	1-C17	ET300931	3-TR11	ZW312470	7-26x		
EC312462	2-C16	ET300931	4-TR2	ZW312471	7-27x		
EC427228	7-40x	ET301165	2-TR18	ZW312472	7-28x		
EC427228	7-41x	ET301165	3-TR10	ZW312473	7-29x		
EC427228	7-42x	ET302465	2-TR8,9	ZW322110	7-20		
EC662128	4-C2	ET302465	2-TR21to24	ZW413188	7-7		
ED245430	3-D1to5	ET305463	1-TR1	ZW413188	7-10x		
ED311752	3-D8	ET305463	2-TR3				
ED311794	6-D1	ET305463	2-TR6				
ED311853	4-D1	ET305463	2-TR13				
ED490511	2-D1	ET305463	2-TR16				
ED490511	2-D5,6	ET305463	2-TR28				
ED490511	2-D10	ET305463	2-TR31				
ED490511	3-D6,7	ET305463	1-TR33,34				
ED490511	3-D9	ET305463	3-TR1				
ED624903	2-D2to4	ET305463	3-TR6				
ED624903	2-D7to9	ET305463	3-TR8				
EF300296	7-50x	ET307195	2-TR2				
EF300598	7-49x	ET307195	3-TR4,5				
EF306088	7-48x	ET307195	2-TR10to12				
EF306125	7-46	ET307195	2-TR14,15				
EF309388	7-45	ET307195	2-TR25to27				
EF309391	7-47x	ET307195	2-TR29,30				
EI311789	3-IC1	ET307195	2-TR32				
EJ293385	4-13,4	ET307195	2-TR35				
EJ293376	4-12	ET307195	3-TR2				
EJ296853	7-33x	ET307195	3-TR5				
EJ311808	7-16	ET307195	3-TR7				
EJ311812	7-39	ET311790	3-TR3				
EJ312463	4-11	ET311791	3-TR4				
EJ312464	4-15	ET311792	2-TR7				
EP249344	2-RL1	ET635220	4-TR1				
EP249344	4-RL1	EV311795	2-VR1				
ER307196	2-R78,77	EV311796	2-VR2				
ER307196	2-R102,103	EV311796	2-VR3				
ER308849	2-R75	EV312338	3-VR1				
ER310323	2-R81	EV315600	2-VR1				
ER310324	2-R55	EV618052	2-VR4				
ER310326	2-R105	EW311816	7-43				
ER310328	2-R106	EZ225145	7-32				
ER310436	2-R82	EZ631945	7-44				
ER311748	3-R12,13	ML311733	8-14				
ER311751	2-R2	ML311734	8-15x				
ER311753	2-R40	MS311709	7-18				
ER311754	2-R41	SA311714	8-12				
ER311755	2-R46,47	SA311742	7-53				
ER311757	2-R51	SB312474	8-6				
ER311757	2-R64	SB312475	8-7x				
ER311759	2-R52	SE311728	8-5				
ER311760	2-R53	SK311735	8-16				
ER311761	2-R54	SK311736	8-17x				
ER311762	2-R80	SK311737	8-18				
ER311763	2-R81	SK311738	8-19x				

When ordering parts, please describe Parts Number, Description, and Model Number in detail.

SECTION 3

SCHEMATIC DIAGRAM

1. PS-200C NO. 4-1 1580852A SCHEMATIC DIAGRAM
2. PS-200C NO. 4-2 1580853A SCHEMATIC DIAGRAM
3. PS-120M NO. 4-3 1580854A SCHEMATIC DIAGRAM
4. PS-200M NO. 4-4 1580855A SCHEMATIC DIAGRAM

TA7220P

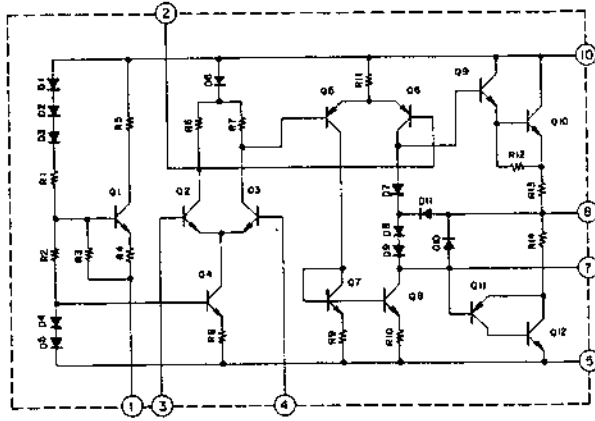

TA7318P

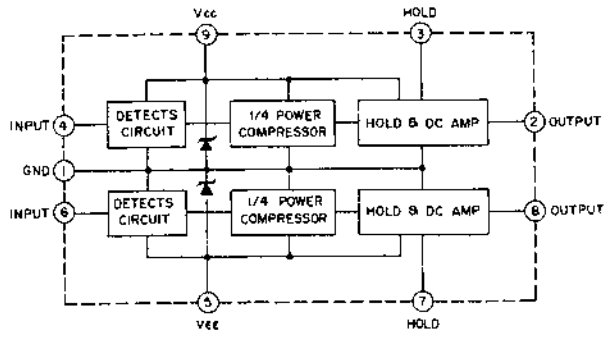

LB1405

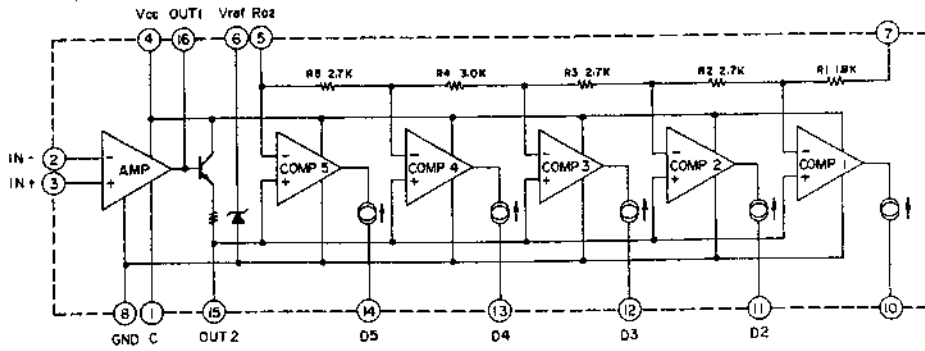

PS-200C

IMPEDANCE
SELECTOR PC BOARD
PC-2033

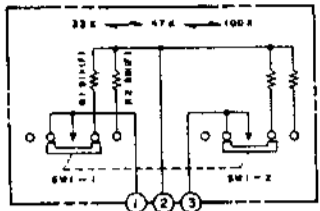

U / T	F1	F2	F3	F4	F5
U / T	800mA 250V	400mA 250V	400mA 250V	315mA 250V	315mA 250V
CSA	800mA 125V			315mA 125V	315mA 125V
AAL	800mA 125V			315mA 125V	315mA 125V
CEE	T 315mA			T 200mA	T 200mA
U K	T 315mA			T 200mA	T 200mA

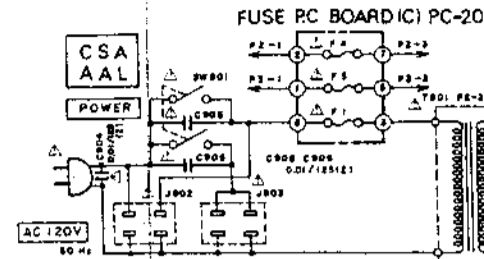

A

B

C

D

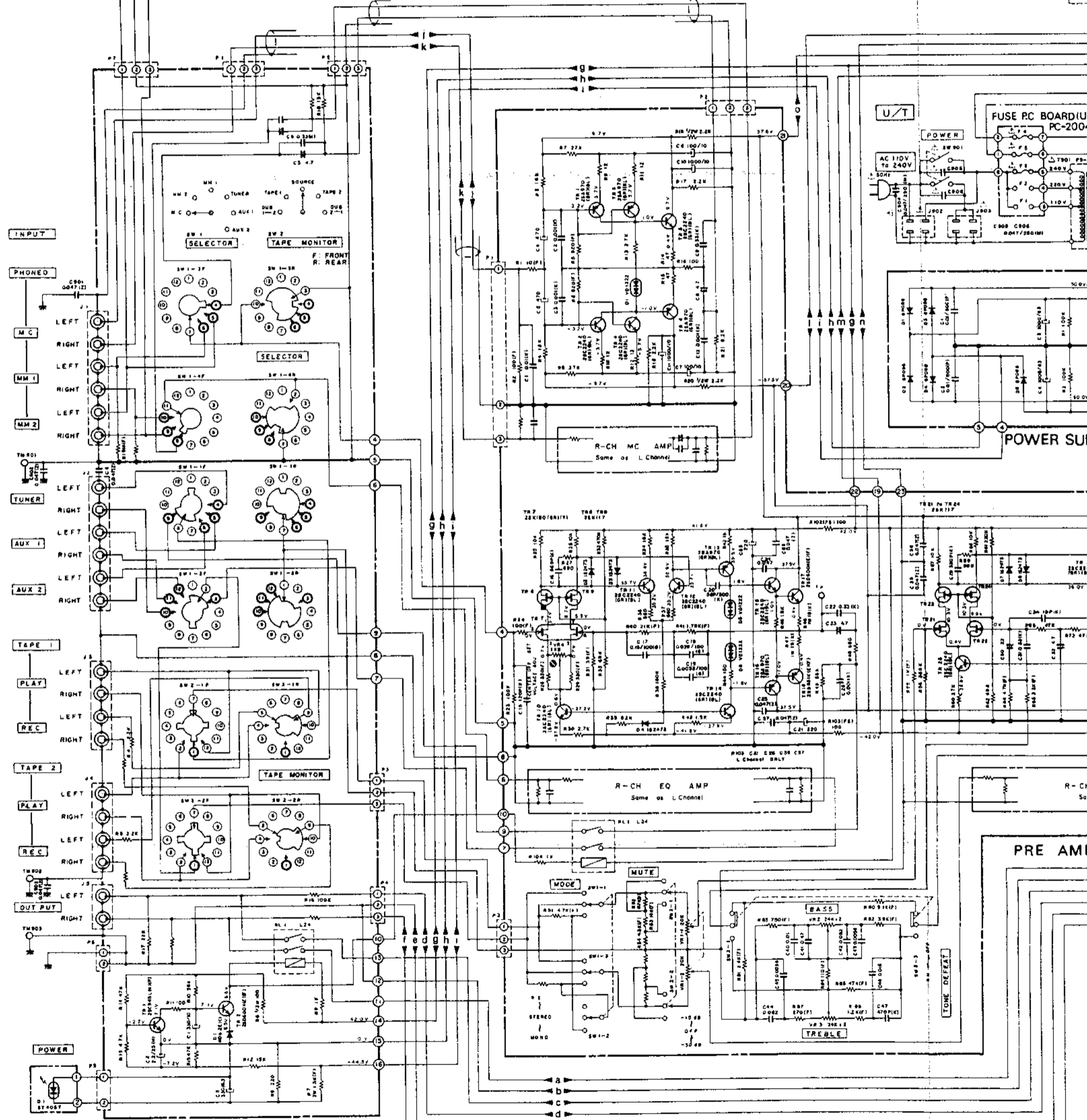

LED PC BOARD (B)
PM-1252
SELECTOR PC BOARD PC-2001

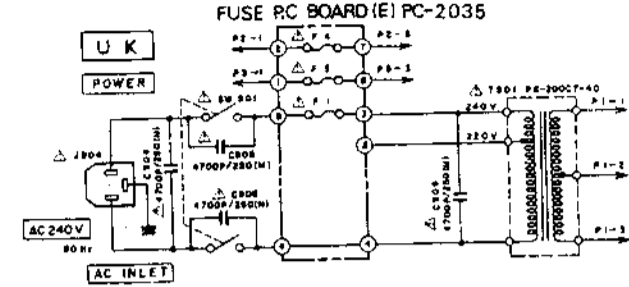
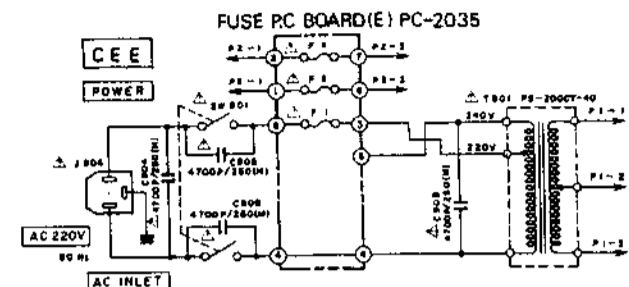
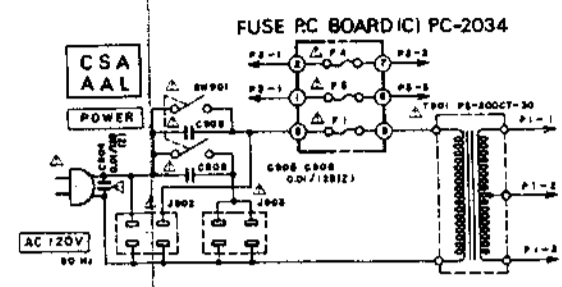

WARNING: Δ INDICATES SAFETY CRITICAL COMPONENTS. FOR CONTINUED SAFETY, REPLACE SAFETY CRITICAL COMPONENTS ONLY WITH MANUFACTURER'S RECOMMENDED PARTS.
 AVERTISSEMENT: Δ IL INDIQUE LES COMPOSANTS CRITIQUES DE SÛRETÉ POUR MAINTENIR LE DEGRÉ DE SÛRETÉ DE L'APPAREIL, NE REMPLACER LES COMPOSANTS DONT LE FONCTIONNEMENT EST CRITIQUE POUR LA SÛRETÉ QUE PAR DES PIÈCES RECOMMANDÉES PAR LE FABRICANT.

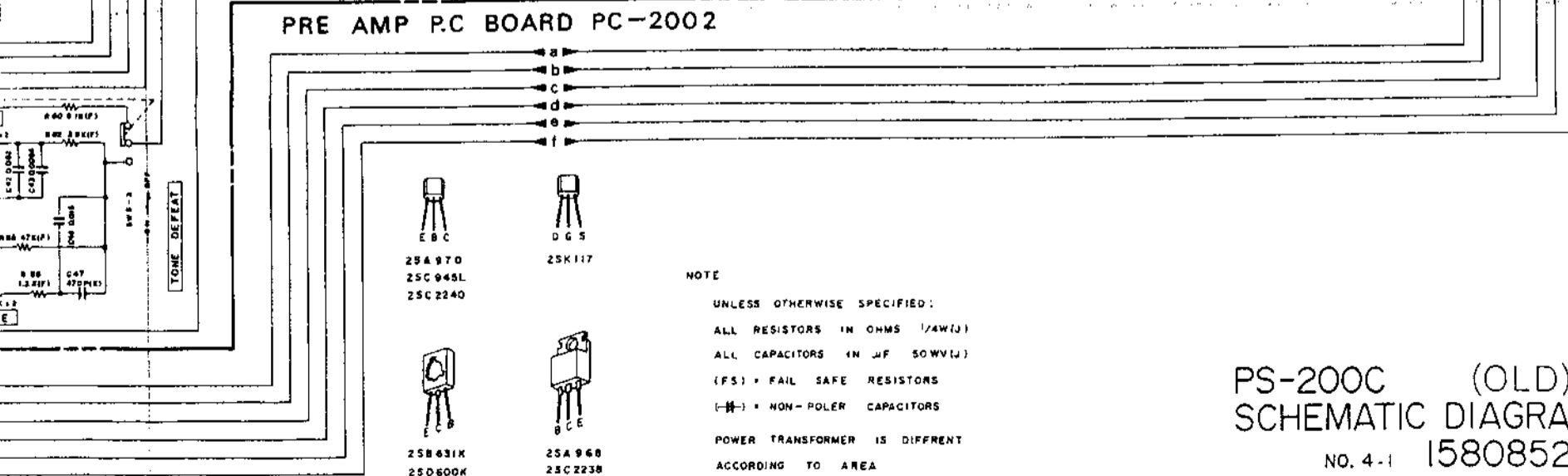
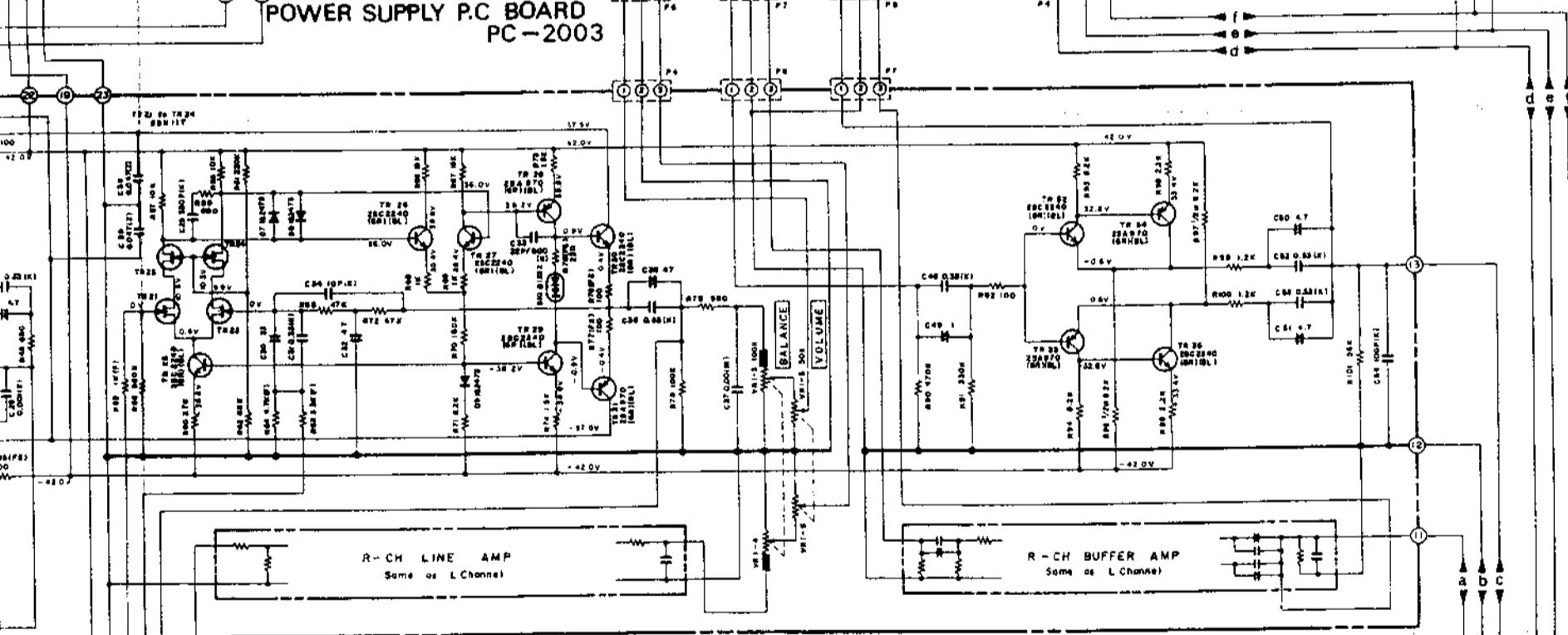
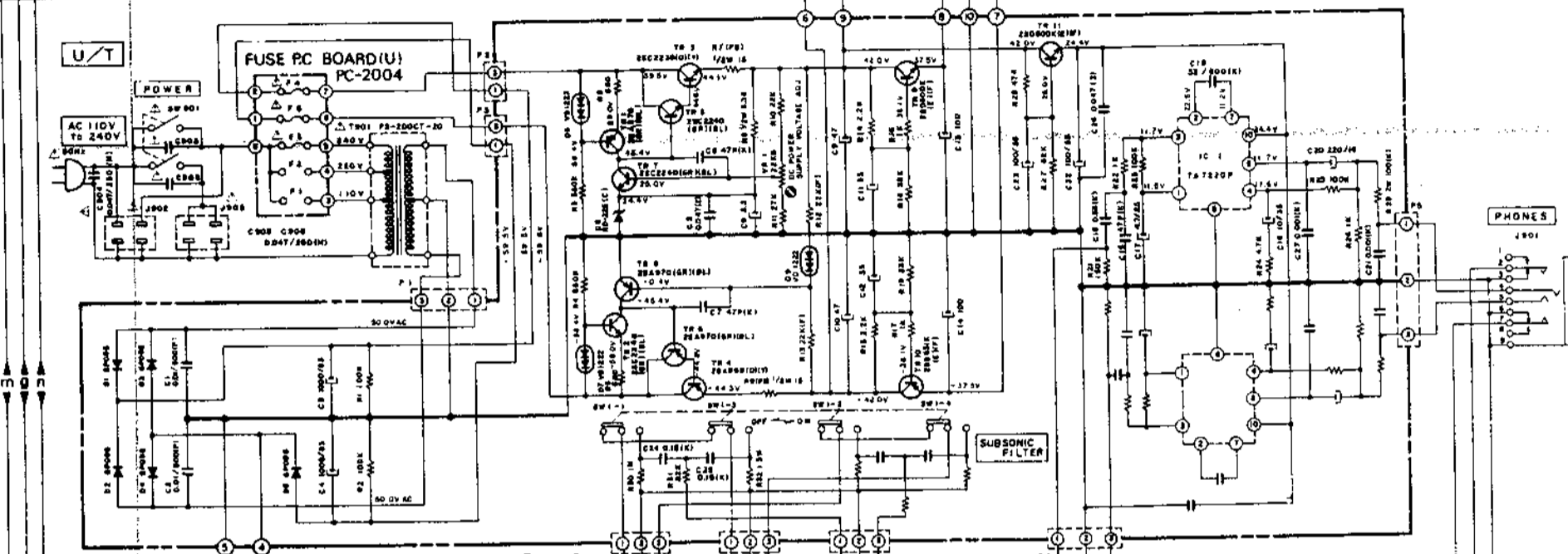

- EBC
- 29A 970
- 25C 945L
- 25C 2240
- DGS
- 25K 117
- 25B 631K
- 25D 600K
- 25A 948
- 25C 2238

NOTE
 UNLESS OTHERWISE SPECIFIED:
 ALL RESISTORS IN OHMS (AW/I)
 ALL CAPACITORS IN μF (SOW/I)
 (FS) = FAIL SAFE RESISTORS
 (-) = NON-POLAR CAPACITORS
 POWER TRANSFORMER IS DIFFERENT
 ACCORDING TO AREA

PS-200C (OLD)
 SCHEMATIC DIAGRAM
 No. 4-1 1580852A

PS-200C

IMPEDANCE SELECTOR PC BOARD PC-2033

* U / T	F 1	F 2	F 3	F 4	F 5
C S A	800mA 250V	400mA 250V	400mA 250V	315mA 250V	315mA 250V
A A L	800mA 125V			315mA 125V	315mA 125V
C E E	T 315mA			T 200mA	T 200mA
U K	T 315mA			T 200mA	T 200mA

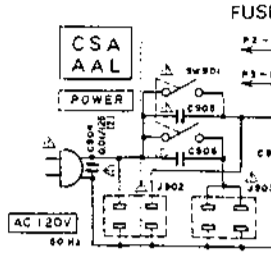

A

B

C

D

LED PC BOARD (B) PM-1252

SELECTOR PC BOARD PC-2001

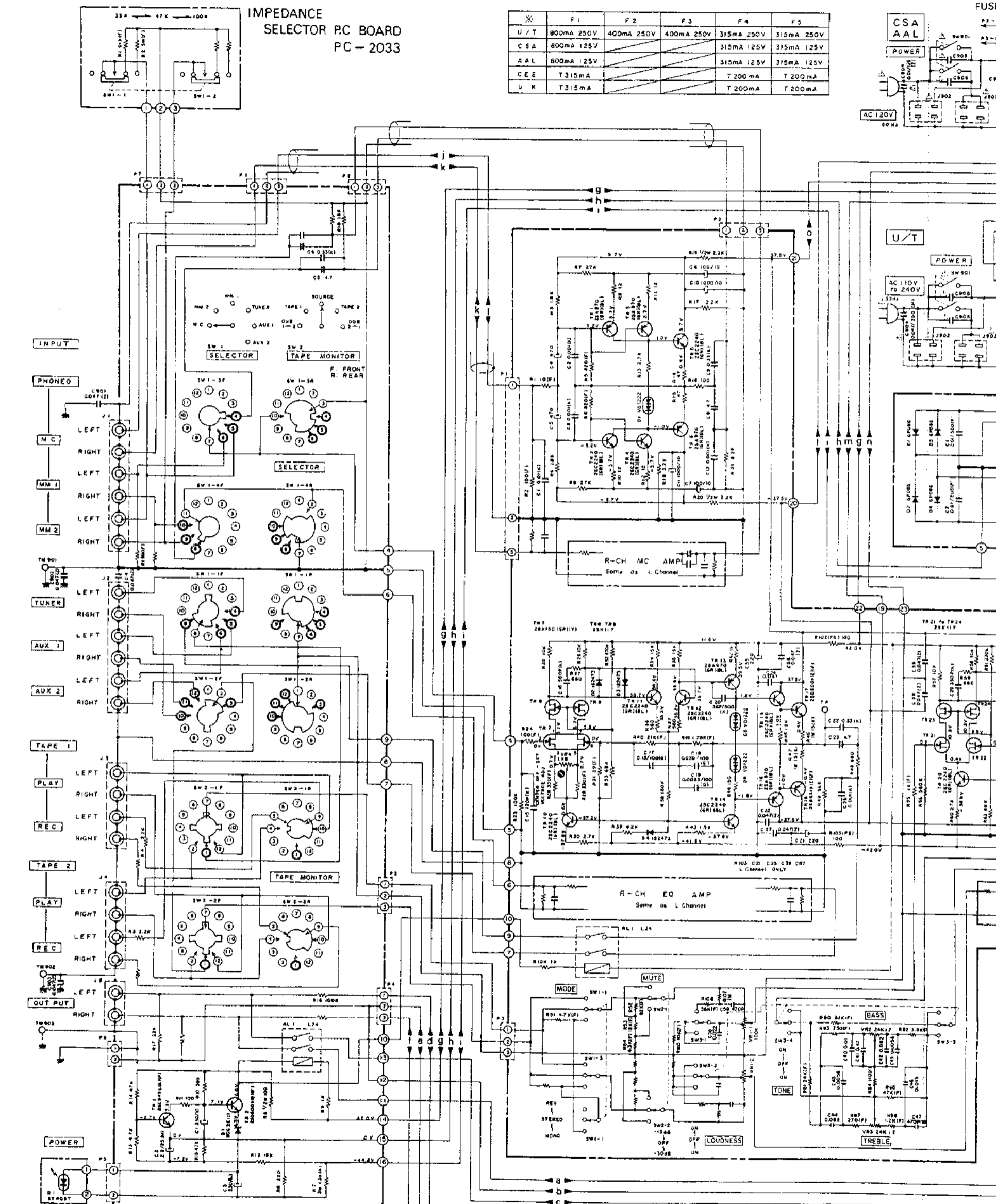

FUSE PC BOARD (C) PC-2034

FUSE PC BOARD (E) PC-2035

FUSE PC BOARD (E) PC-2036

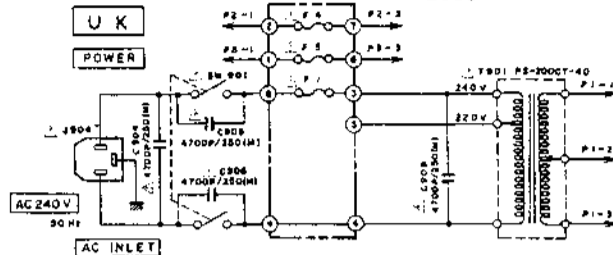
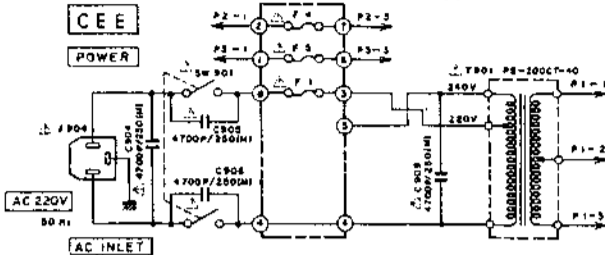
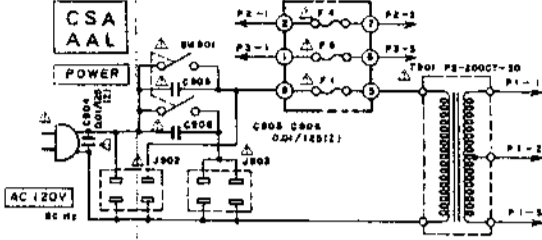

WARNING: Δ INDICATES SAFETY CRITICAL COMPONENTS FOR CONTINUED SAFETY. REPLACE SAFETY CRITICAL COMPONENTS ONLY WITH MANUFACTURER'S RECOMMENDED PARTS.

AVERTISSEMENT: Δ IL INDIQUE LES COMPOSANTS CRITIQUES DE SÛRETÉ. POUR MAINTENIR LE DEGRÉ DE SÛRETÉ DE L'APPAREIL NE REMPLACEZ LES COMPOSANTS DONT LE FONCTIONNEMENT EST CRITIQUE POUR LA SÛRETÉ QUE PAR DES PIÈCES RECOMMANDÉES PAR LE FABRICANT.

FUSE PC BOARD (U) PC-2004

POWER SUPPLY P.C. BOARD PC-2003

PRE AMP P.C. BOARD PC-2056

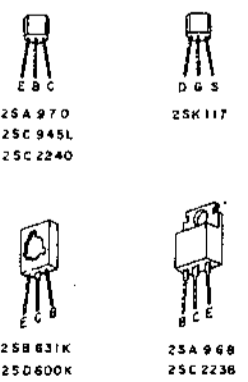
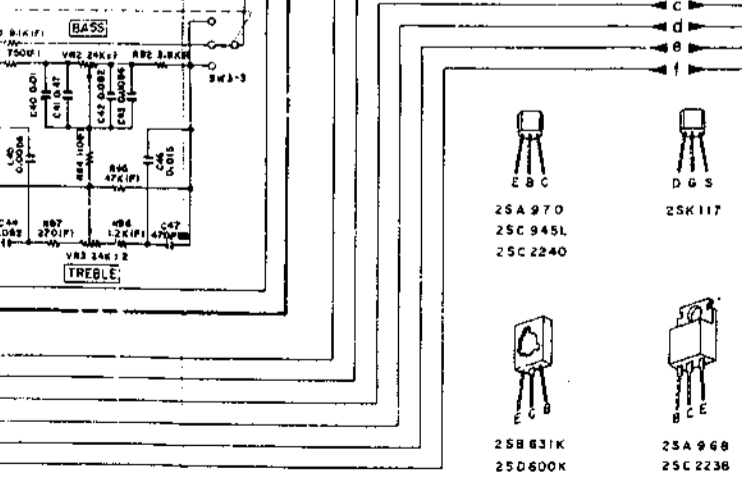
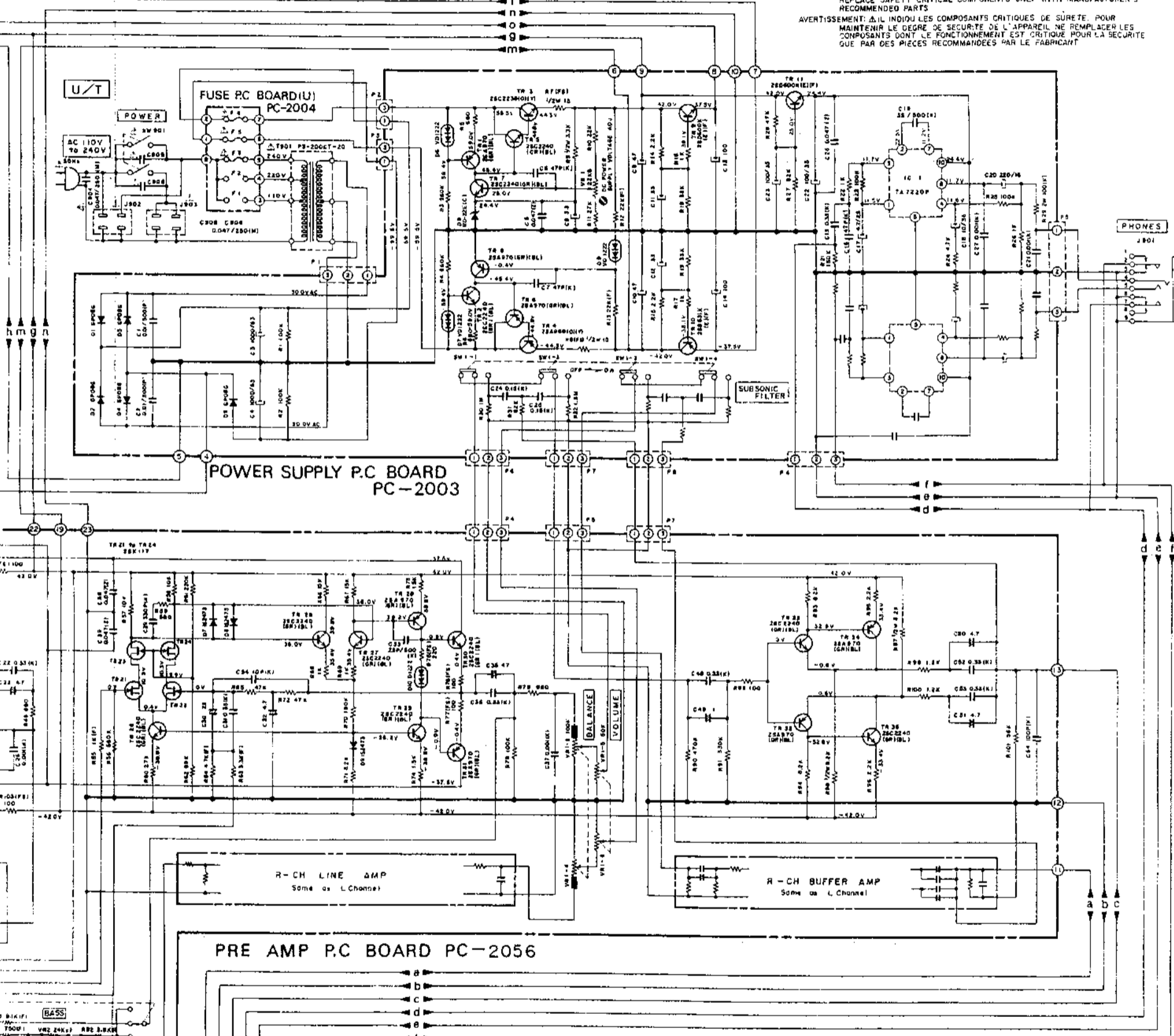

NOTE

UNLESS OTHERWISE SPECIFIED:

ALL RESISTORS IN OHMS 1/4W(1/2)

ALL CAPACITORS IN μF 50WV(5)

(FS) = FAIL SAFE RESISTORS

(-/-) = NON-POLAR CAPACITORS

POWER TRANSFORMER IS DIFFRENT ACCORDING TO AREA

PS-200C (NEW) SCHEMATIC DIAGRAM NO. 4-2 1580853A

PS-120M

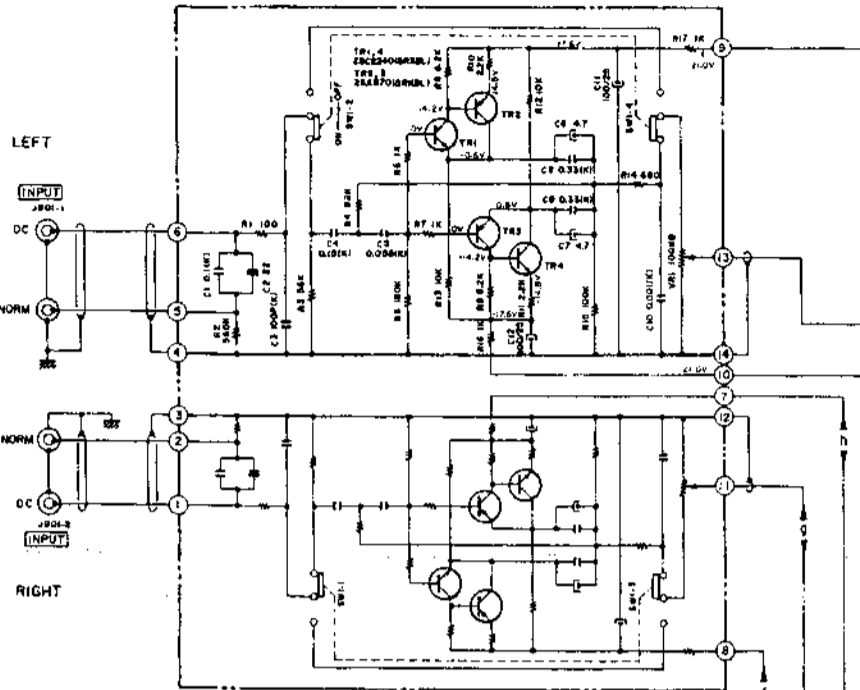

FILTER P.C. BOARD PM-1203

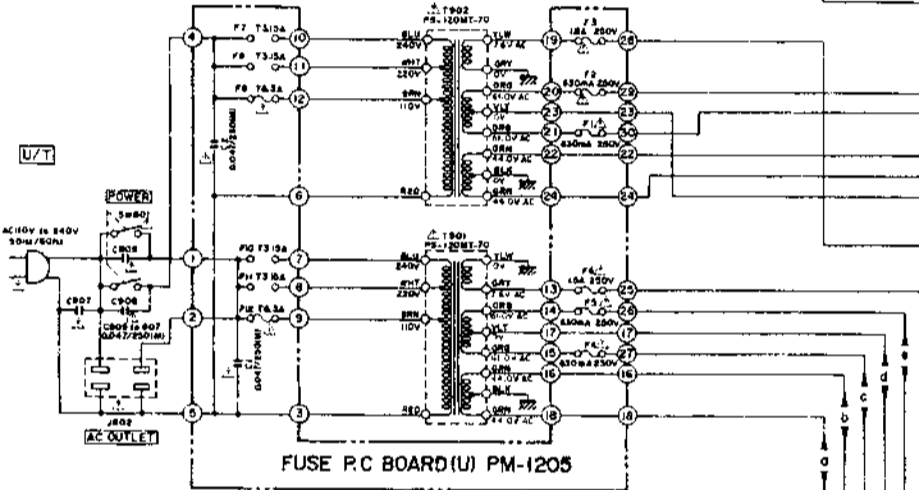

FUSE P.C. BOARD (U) PM-1205

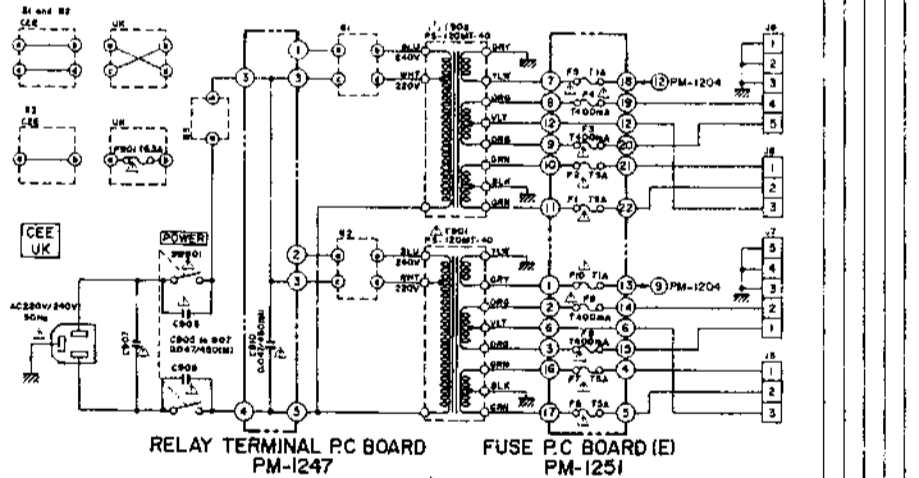

RELAY TERMINAL P.C. BOARD PM-1247

FUSE P.C. BOARD (E) PM-1251

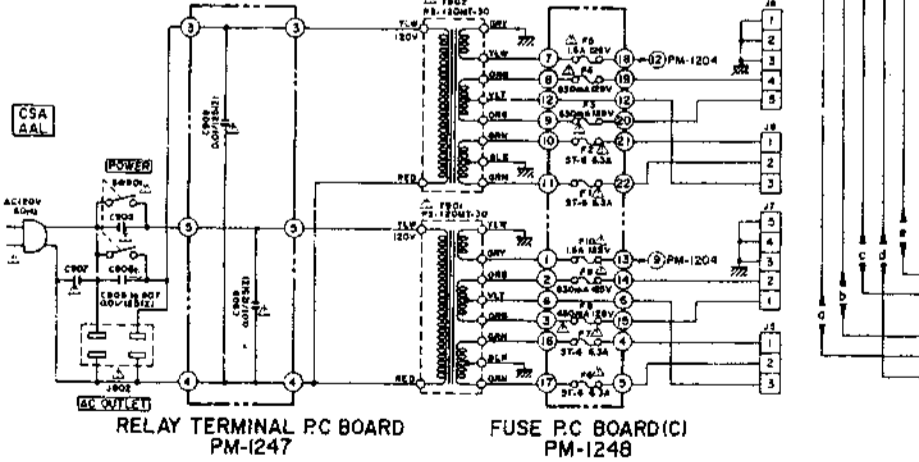

RELAY TERMINAL P.C. BOARD PM-1247

FUSE P.C. BOARD (C) PM-1248

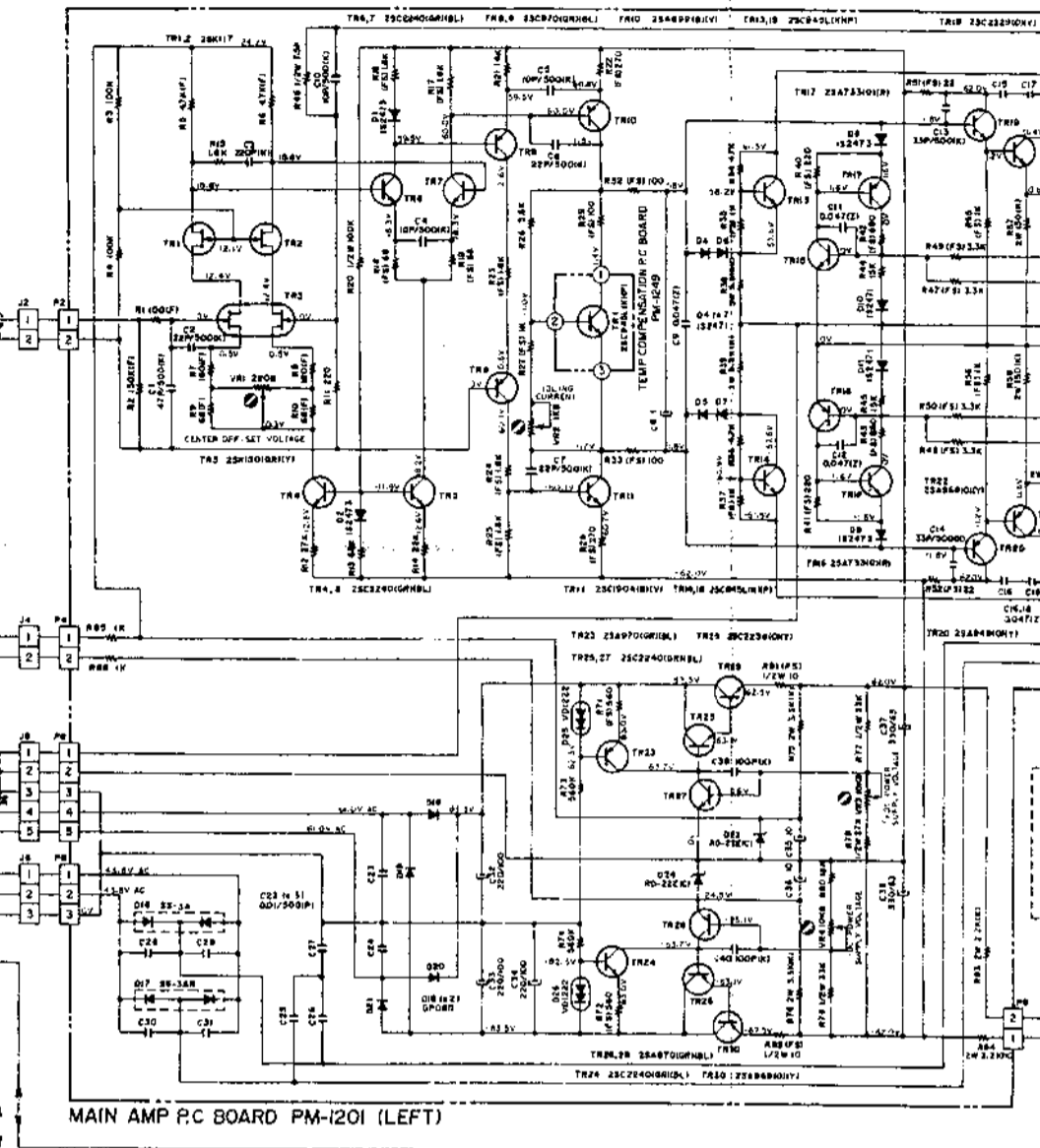

MAIN AMP P.C. BOARD PM-1201 (LEFT)

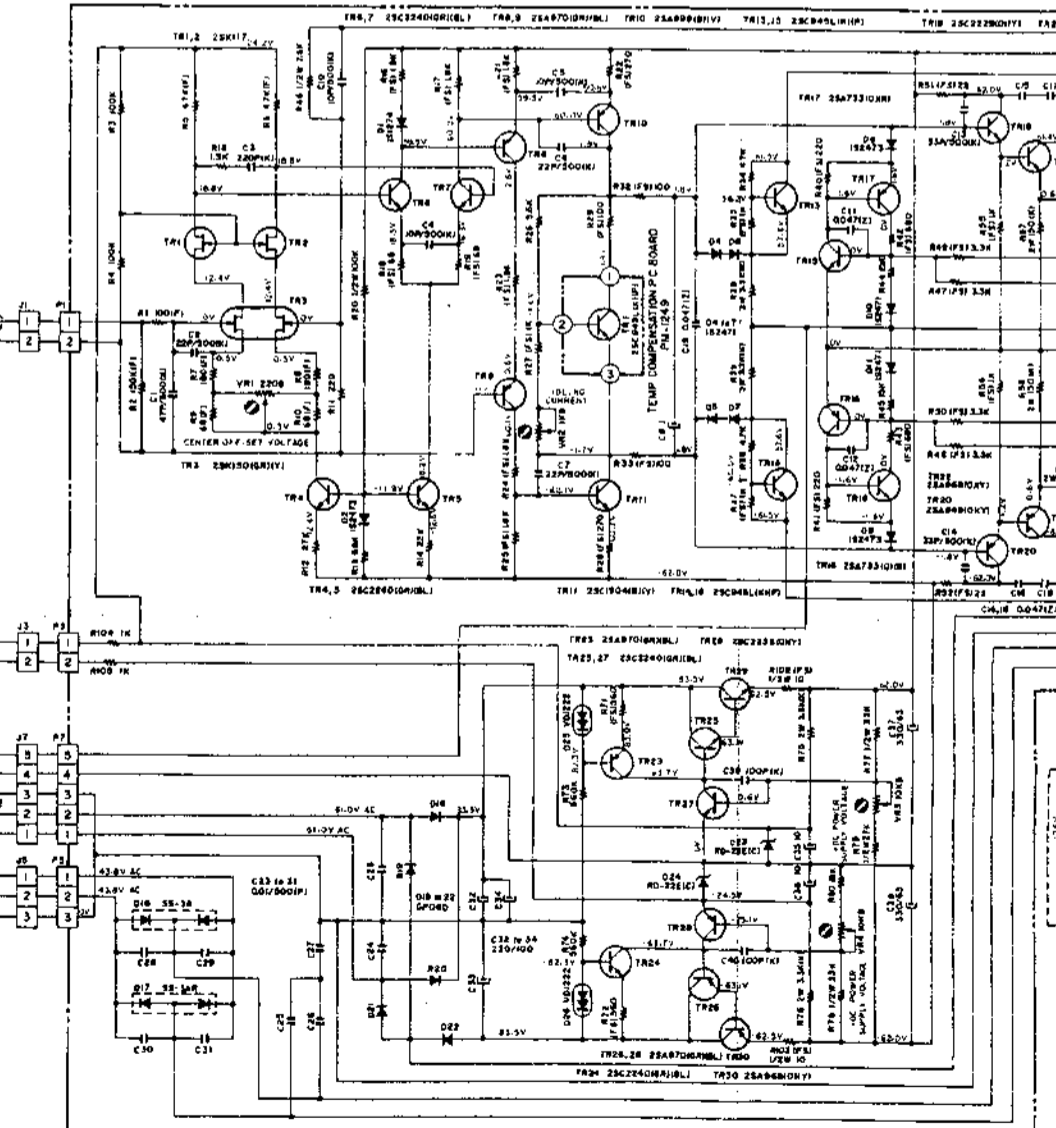

MAIN AMP P.C. BOARD PM-1202 (RIGHT)

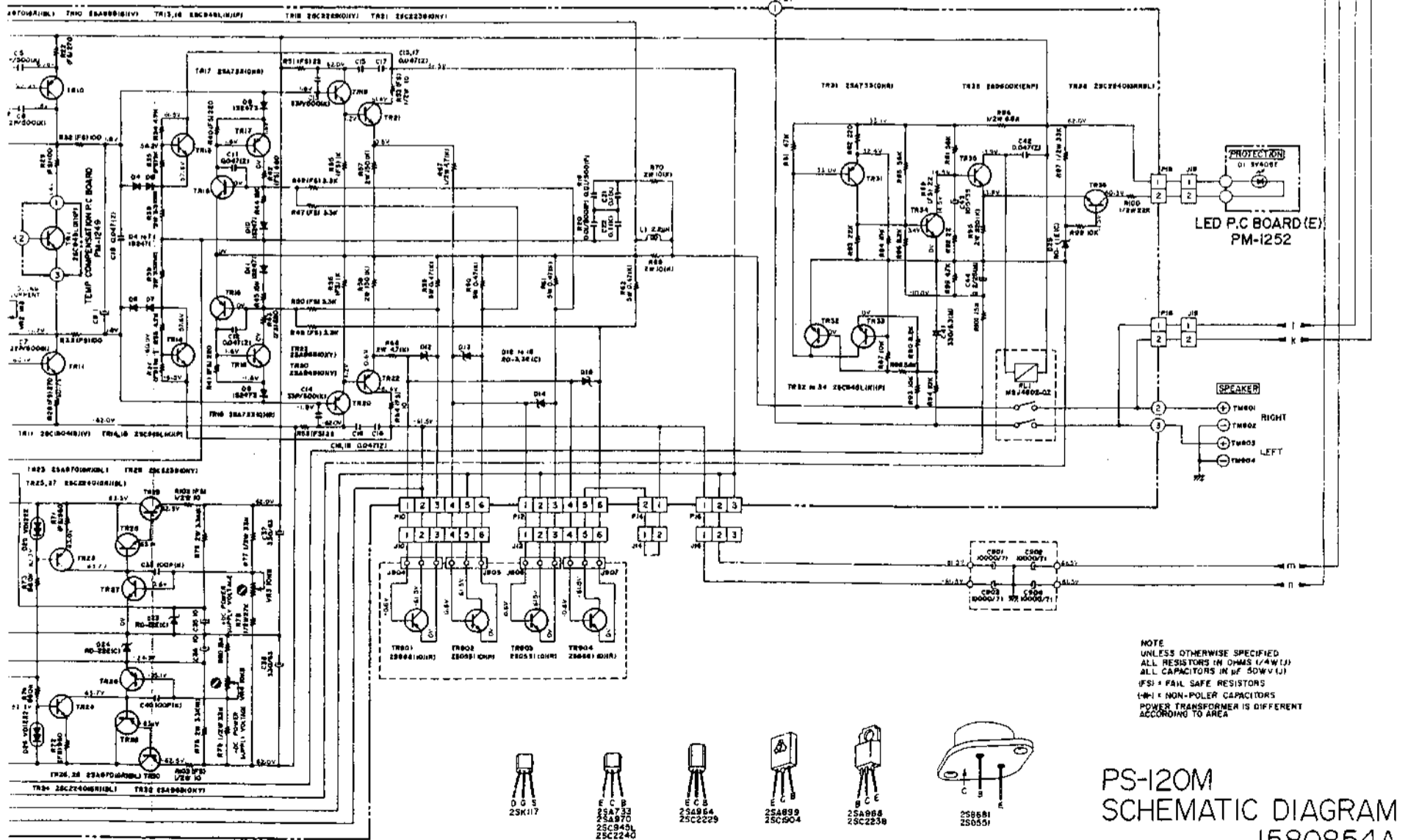
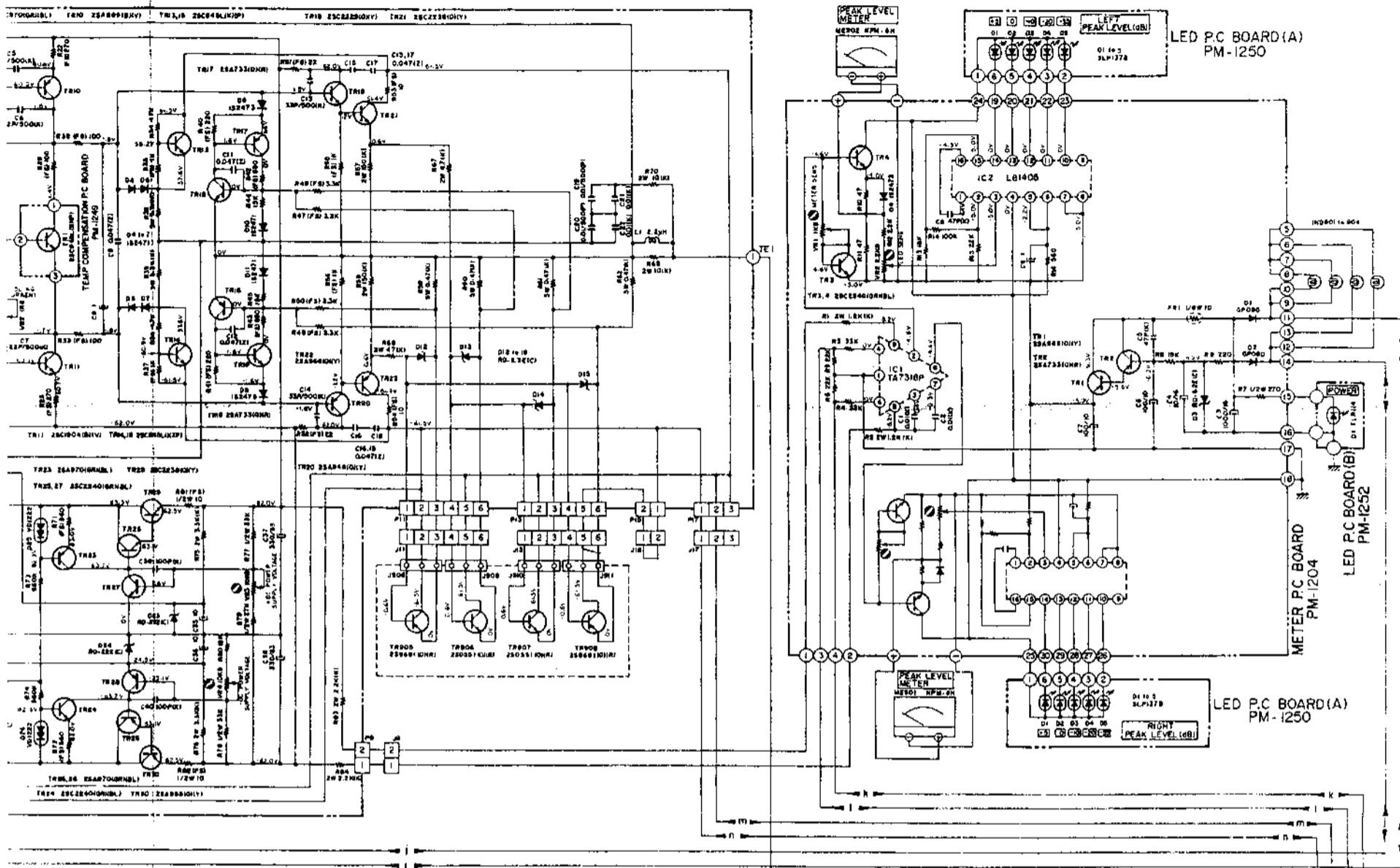

NOTE
UNLESS OTHERWISE SPECIFIED
ALL RESISTORS IN OHMS (1/4W 1%)
ALL CAPACITORS IN P.F. (50WV 1%)
(FS) = FAIL SAFE RESISTORS
(-M) = NON-POLAR CAPACITORS
POWER TRANSFORMER IS DIFFERENT
ACCORDING TO AREA

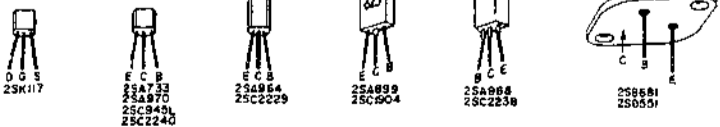

PS-120M
SCHEMATIC DIAGRAM
NO.4-3 1580854A

PS-200M

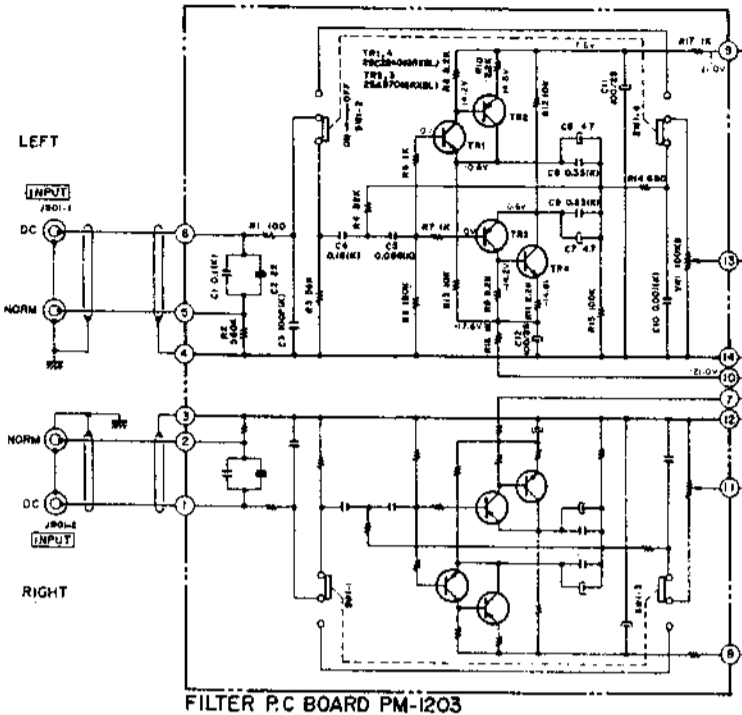

FILTER P.C. BOARD PM-1203

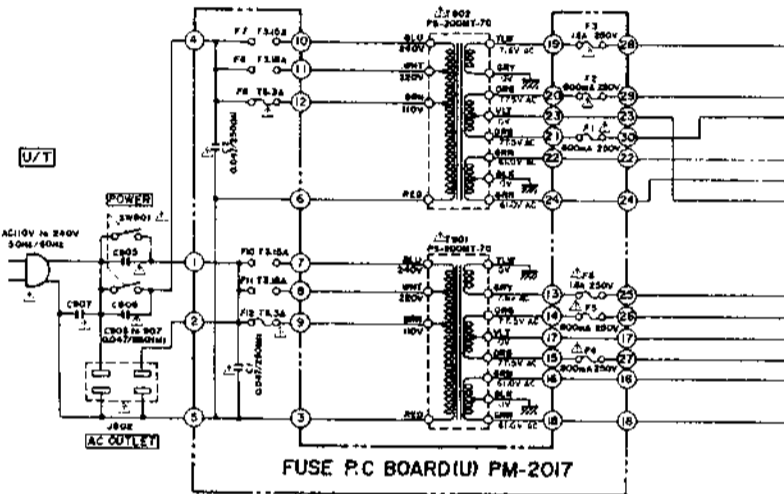

FUSE P.C. BOARD (U) PM-2017

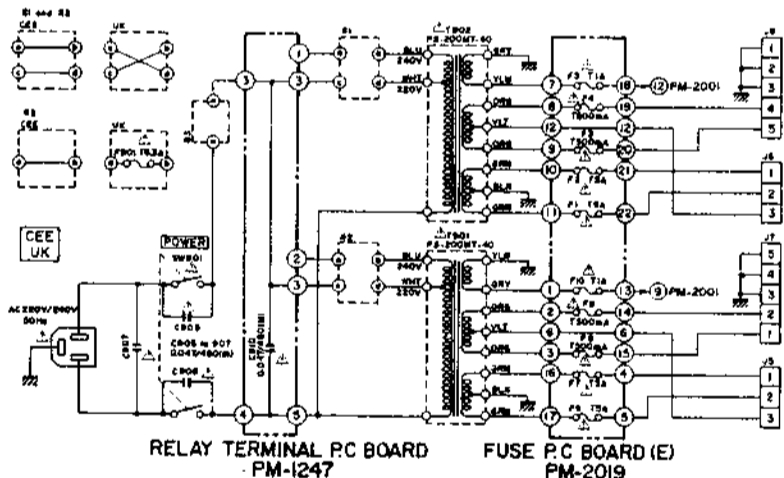

RELAY TERMINAL P.C. BOARD PM-1247

FUSE P.C. BOARD (E) PM-2019

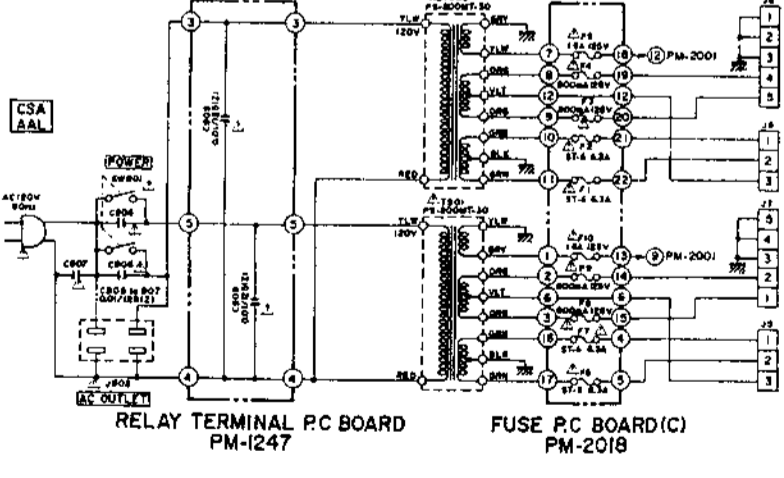

RELAY TERMINAL P.C. BOARD PM-1247

FUSE P.C. BOARD (C) PM-2018

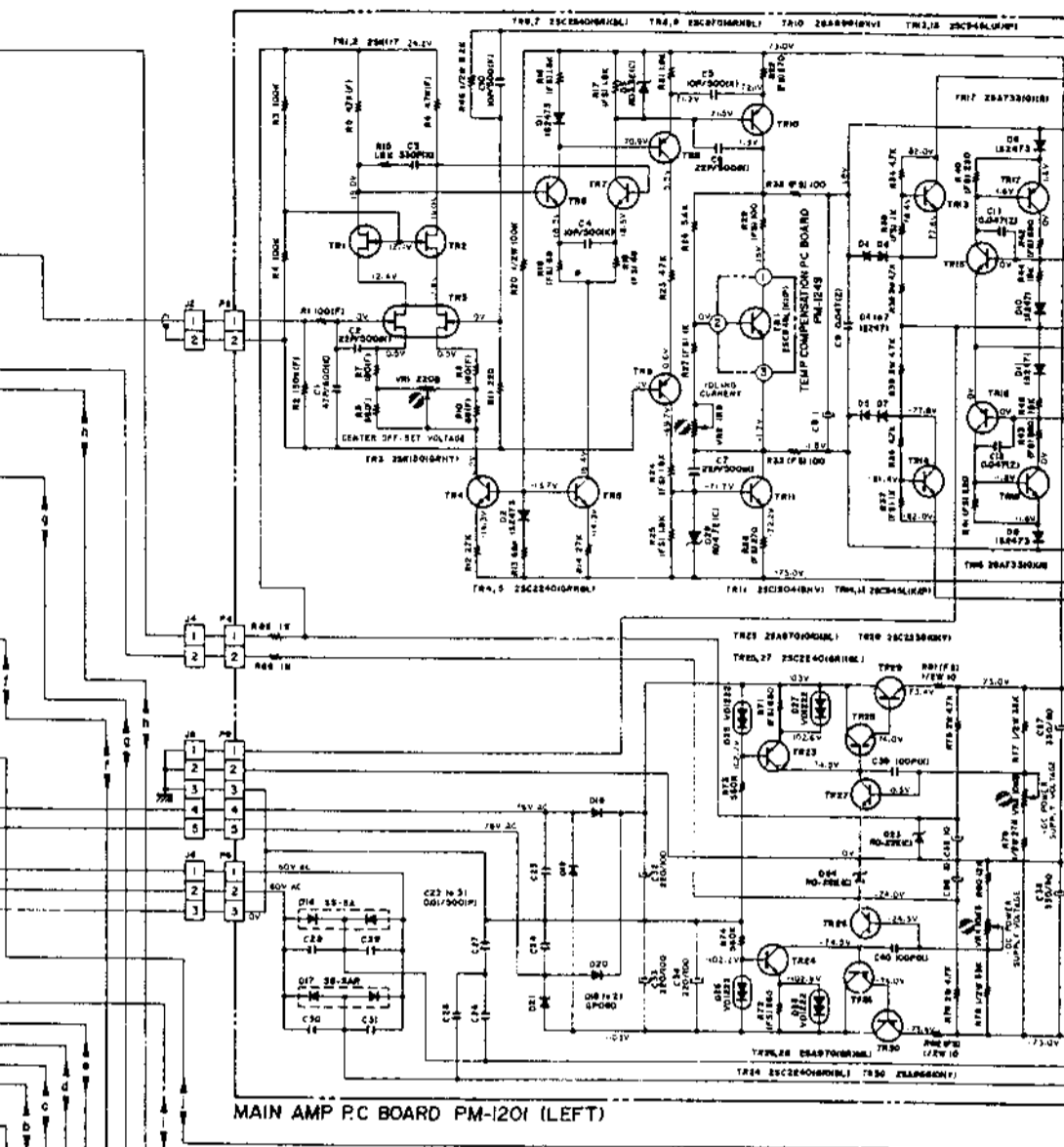

MAIN AMP P.C. BOARD PM-1201 (LEFT)

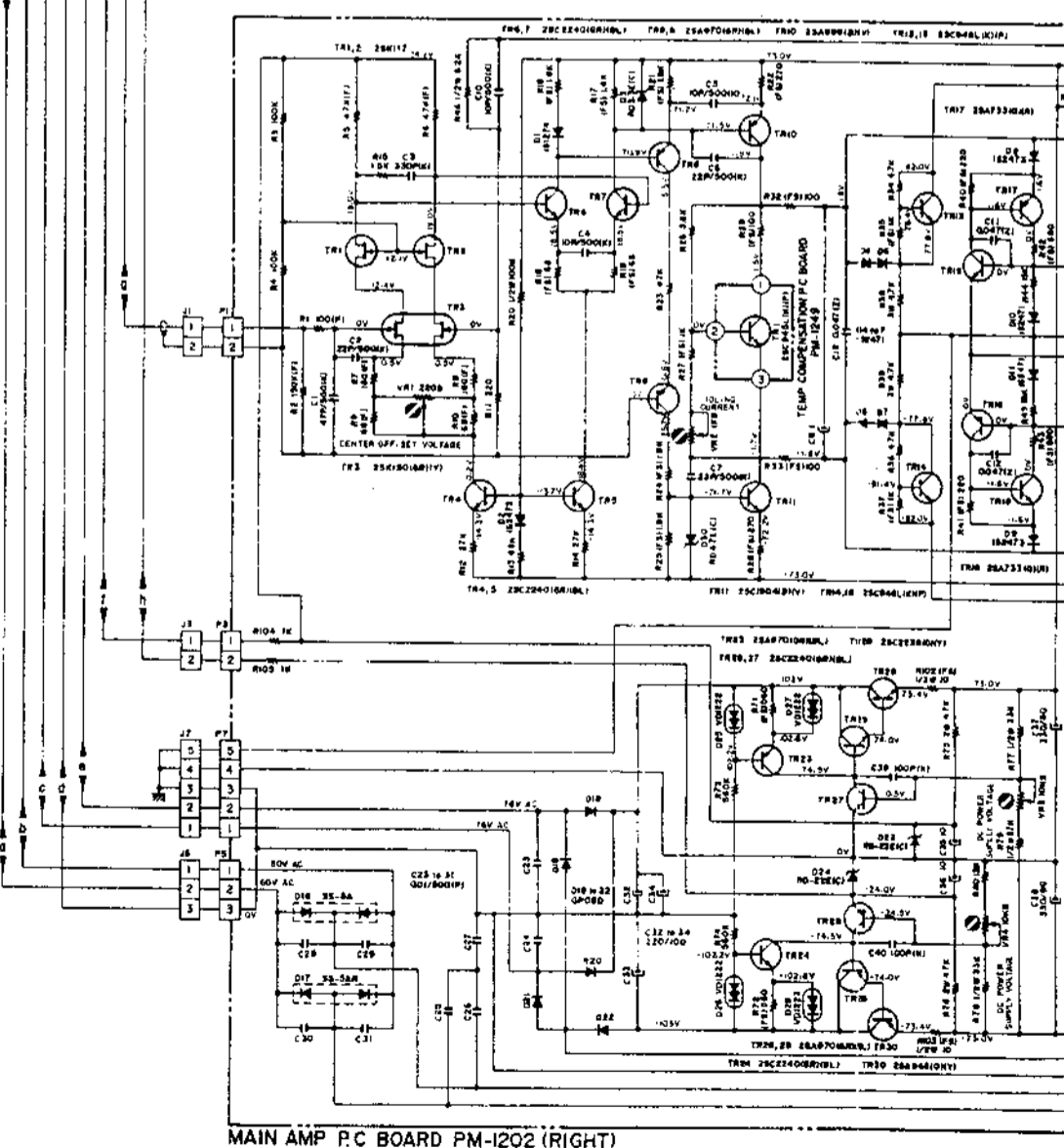

MAIN AMP P.C. BOARD PM-1202 (RIGHT)

