

AKAI SERVICE MANUAL

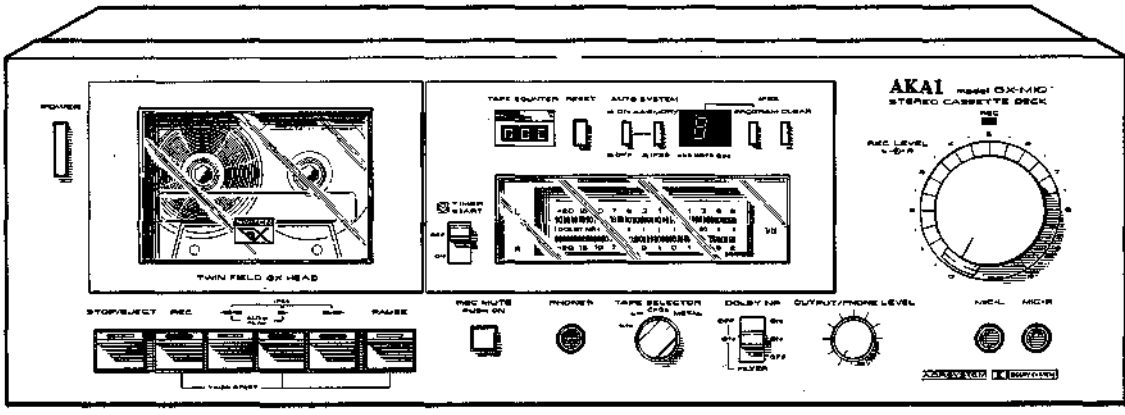

STEREO CASSETTE DECK

MODEL **GX-M10**

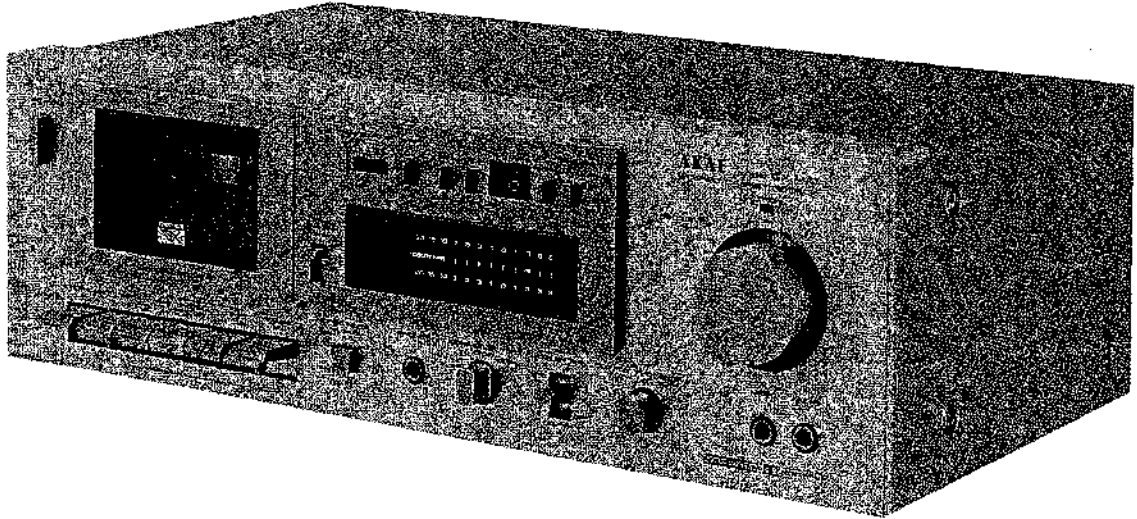

STEREO CASSETTE DECK

MODEL GX-M10

ALSO APPLICABLE TO BLACK PANEL MODEL

SECTION 1	SERVICE MANUAL	3
SECTION 2	PARTS LIST	35
SECTION 3	SCHEMATIC DIAGRAM	51

SECTION 1

SERVICE MANUAL

TABLE OF CONTENTS

I. TECHNICAL DATA	4
II. DISMANTLING OF UNIT	5
III. CONTROLS	6
IV. PRINCIPAL PARTS LOCATION	7
V. VOLTAGE AND CYCLE CONVERSION	8
1. VOLTAGE CONVERSION	8
2. CYCLE CONVERSION	8
VI. IPSS CIRCUITRY OPERATION EXPLANATION	9
VII. TIMER START SWITCH OPERATION	17
VIII. AUTO STOP MECHANISM OPERATION	18
IX. MECHANISM ADJUSTMENT	20
X. HEAD ADJUSTMENT	22
XI. AMPLIFIER ADJUSTMENT	22
XII. DC RESISTANCE OF VARIOUS HEADS	28
XIII. CLASSIFICATION OF VARIOUS P.C BOARDS	28

For basic adjustments, measuring methods, and operating principles, refer to GENERAL TECHNICAL MANUAL.

I. TECHNICAL DATA

TRACK SYSTEM	4 track 2 channel stereo system
TAPE	Philips type cassette
TAPE SPEED	4.76 cm/s \pm 1.5% (1-7/8 ips. \pm 1.5%)
HEADS	(2): Erase head \times 1 Twin field Super GX head \times 1
MOTOR	(1): Electronically speed controlled DC motor
WOW & FLUTTER	Less than 0.04% WRMS. 0.14% (DIN 45500)
TAPE WINDING TIME	90 sec. using a C-60 cassette tape
FREQUENCY RESPONSE	LN 30 to 15,000 Hz \pm 3 dB (-20 VU) LH 30 to 16,000 Hz \pm 3 dB (-20 VU) CrO ₂ (SA) 30 to 16,500 Hz \pm 3 dB (-20 VU) 30 to 8,000 Hz \pm 3 dB (0 VU) Metal 30 to 19,000 Hz \pm 3 dB (-20 VU) 30 to 12,000 Hz \pm 3 dB (0 VU)
SIGNAL TO NOISE RATIO	LN better than 58 dB LH better than 59 dB CrO ₂ (SA) better than 60 dB Metal better than 61 dB (Measured via tape with peak recording level) Dolby NR switch ON: Improves up to 10 dB above 5 kHz
HARMONIC DISTORTION	LN less than 0.8% LH less than 0.8% CrO ₂ (SA) less than 0.7% Metal less than 0.6%
CHANNEL SEPARATION	27 dB at 1,000 Hz
CROSS TALK	60 dB at 1,000 Hz
INPUT	MIC: 0.3 mV (Input impedance 5.0 kohms) Required microphone impedance: 600 ohms Line: 70 mV (Input impedance 47 kohms)
OUTPUT	Line: 410 mV at 0 VU Required load impedance: more than 20 kohms Phone: 100 mV/8 ohms at 0 VU
DIN	Input: 2.0 mV (Input impedance 10 kohms) Output: 410 mV Required load impedance: more than 20 kohms
DIMENSIONS	440(W) \times 143(H) \times 250(D) mm (17.3 \times 5.6 \times 9.8")
WEIGHT	6.0 kg (13.2 lbs)
POWER CONSUMPTION	12 W
POWER REQUIREMENTS	100V, 50/60 Hz for Japan 120V, 60 Hz for U.S.A. & Canada 220V, 50 Hz for European countries except U.K. 240V, 50 Hz for U.K. & Australia 110/120/220/240V switchable, 50/60 Hz for the other countries

* For improvement purposes, specifications and design are subject to change without notice.

* "Dolby" and the Double D symbol are trademarks of Dolby Laboratories.
(Manufactured under license from Dolby Laboratories).

II. DISMANTLING OF UNIT

In case of trouble, etc. necessitating dismantling, please dismantle in the order shown in the photographs. Reassemble in reverse order.

1

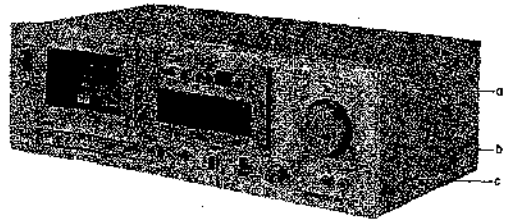

SCREWS

5

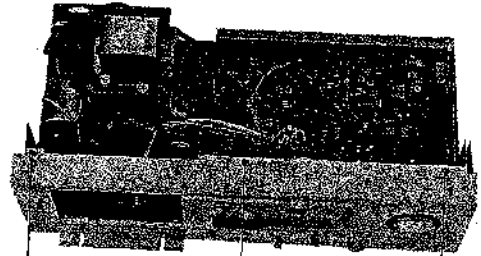

SCREWS

2

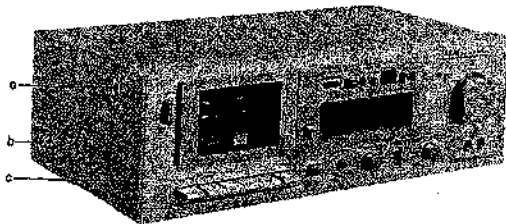

SCREWS

6

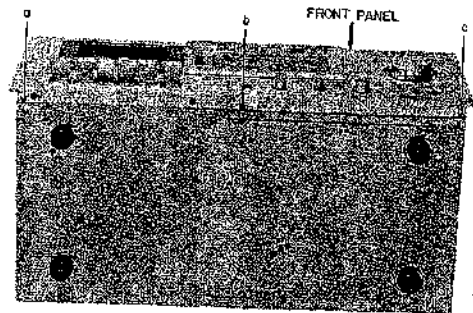

SCREWS

3

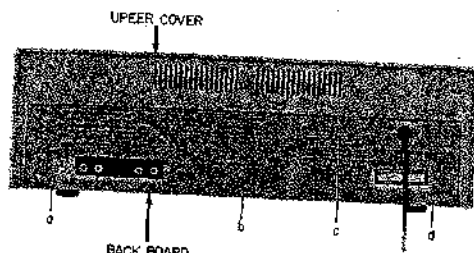

BACK BOARD

SCREWS

7

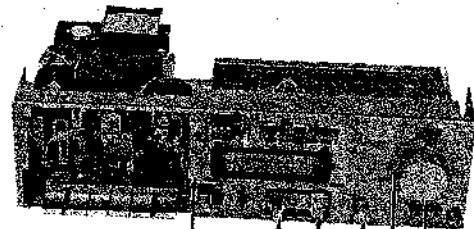

CONTROL KNOBS

4

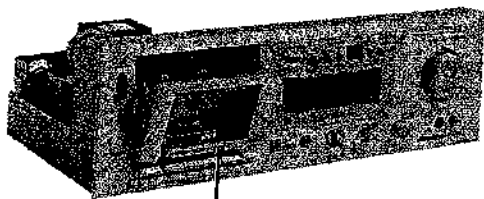

LID PANEL

Pull toward you both lower-ends of holder.

8

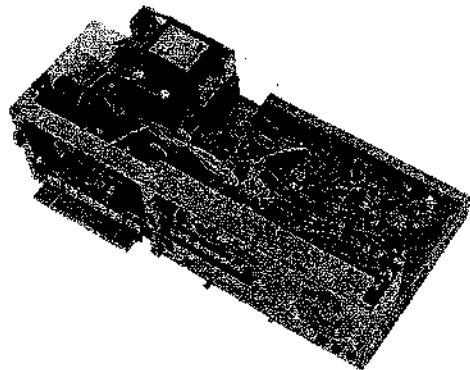

III. CONTROLS

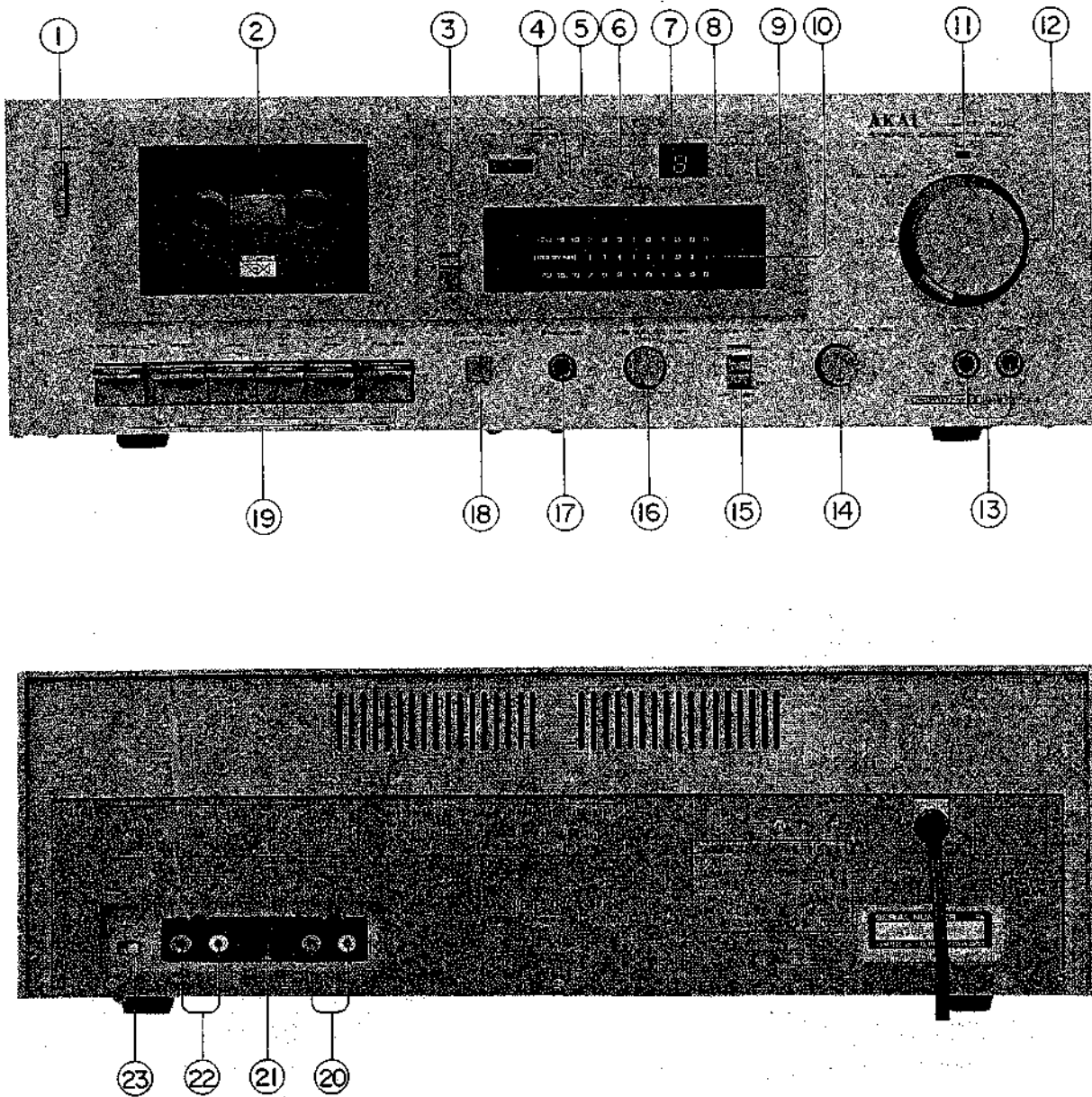

Fig. 1 Controls

- | | |
|--|--|
| 1. POWER SWITCH | 13. MICROPHONE JACKS |
| 2. CASSETTE RECEPTACLE | 14. OUTPUT/PHONES LEVEL CONTROL |
| 3. TIMER START SWITCH | 15. DOLBY NR SWITCH AND FILTER |
| 4. INDEX COUNTER AND RESET BUTTON | 16. TAPE SELECTOR |
| 5. AUTO SYSTEM SWITCH | 17. HEADPHONE JACK |
| 6. MEMORY/IPSS SWITCH | 18. REC MUTE |
| 7. PROGRAM DISPLAY | 19. OPERATING KEYS |
| 8. IPSS PROGRAM SWITCH | 20. LINE OUTPUT JACKS |
| 9. CLEAR SWITCH | 21. DIN JACK (The JPN, USA models do not have this facility) |
| 10. FL DISPLAY BAR METER | 22. LINE INPUT JACKS |
| 11. RECORDING INDICATOR LAMP | 23. INPUT SELECTOR SWITCH |
| 12. LEFT \rightarrow RIGHT RECORDING
LEVEL CONTROLS | (The JPN, USA models do not have this facility) |

IV. PRINCIPAL PARTS LOCATION

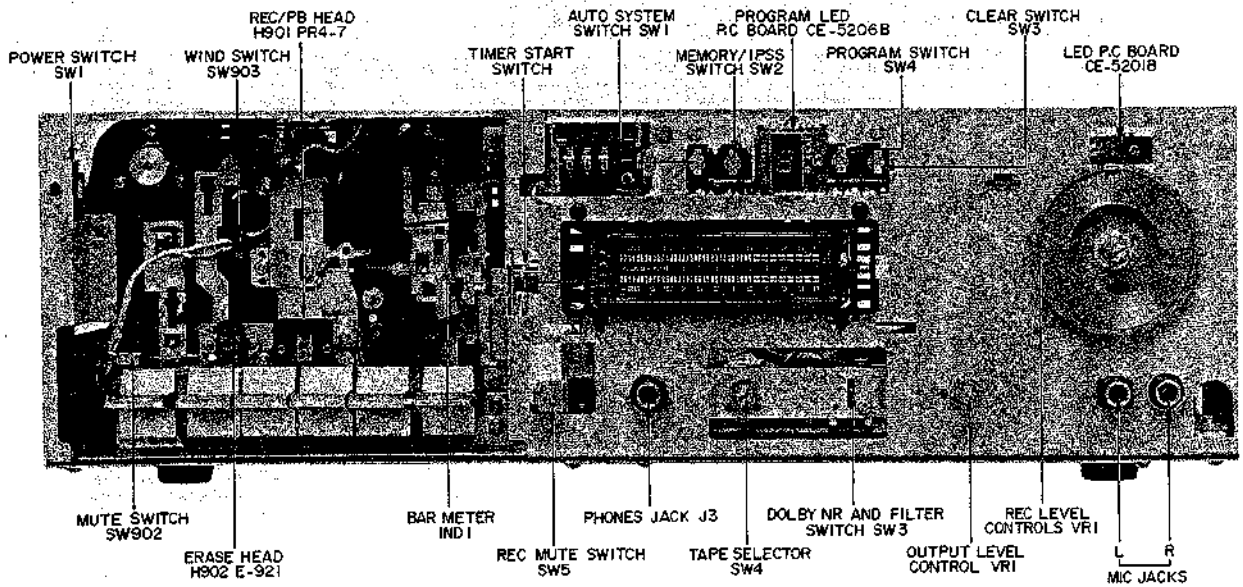

Fig. 2 Front View

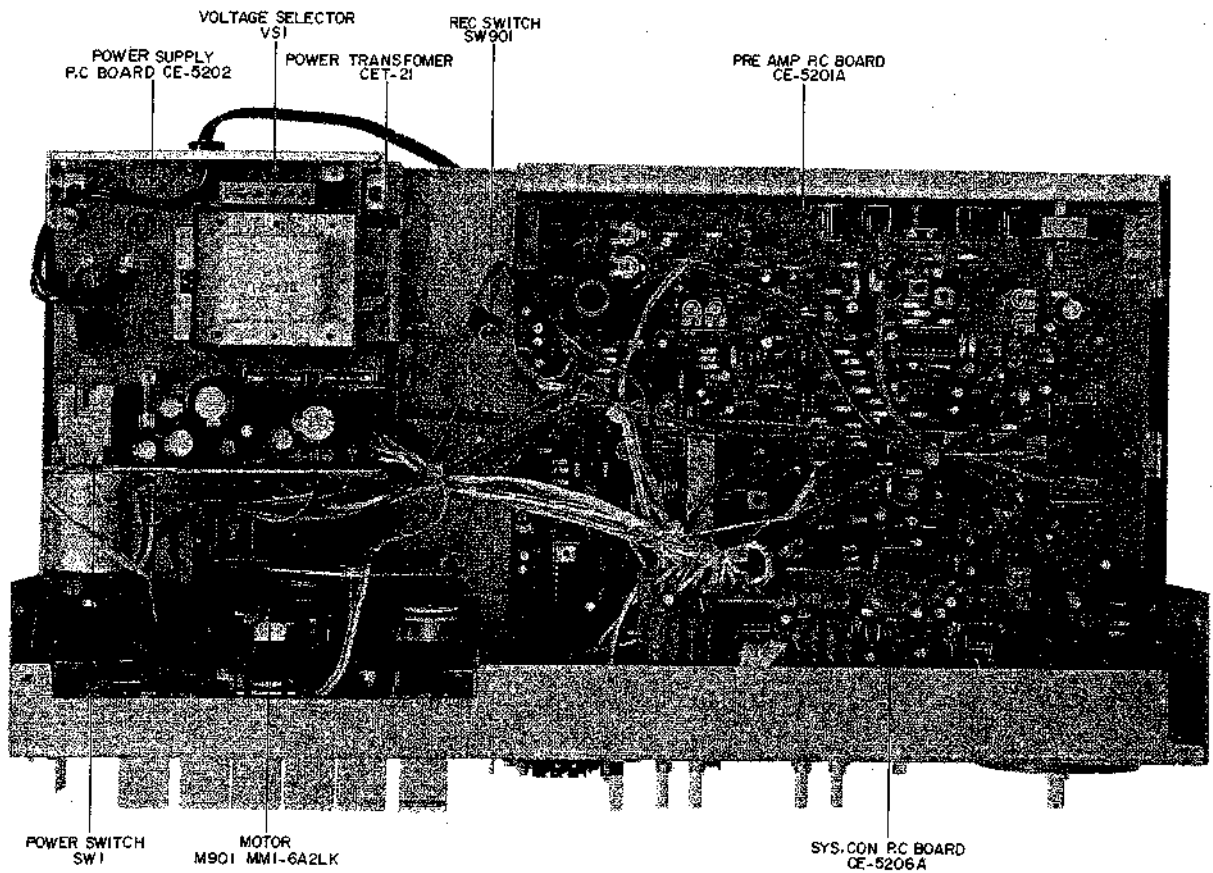

Fig. 3 Top View

V. VOLTAGE AND CYCLE CONVERSION

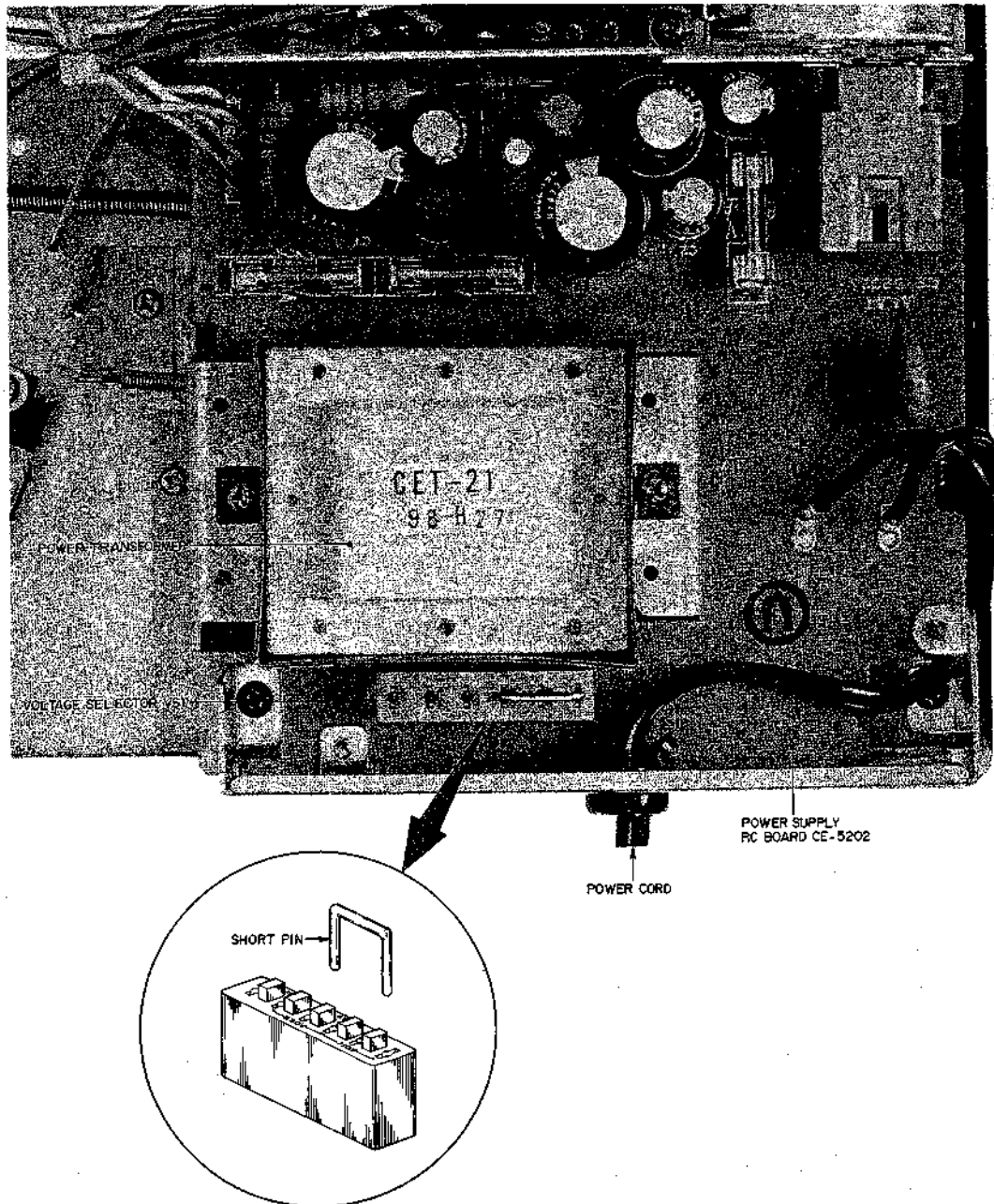

Fig. 4 Voltage Conversion (U/T Model)

1. VOLTAGE CONVERSION

Models for Canada, Europe, USA, UK, Australia and Japan are not equipped with this facility.

Each machine is preset at the factory according to destination, but some machines can be set to 110V, 120V, 220V or 240V as required.

If voltage change is necessary, this can be accomplished as follows:

1. Disconnect power cord.

2. Loosen holding screws and remove upper cover and back board.

3. Remove short pin plug from present holes and replace in correct holes. Follow the markings explicitly.

2. CYCLE CONVERSION

With DC motor, cycle conversion is not necessary.

VI. IPSS CIRCUITRY OPERATION EXPLANATION

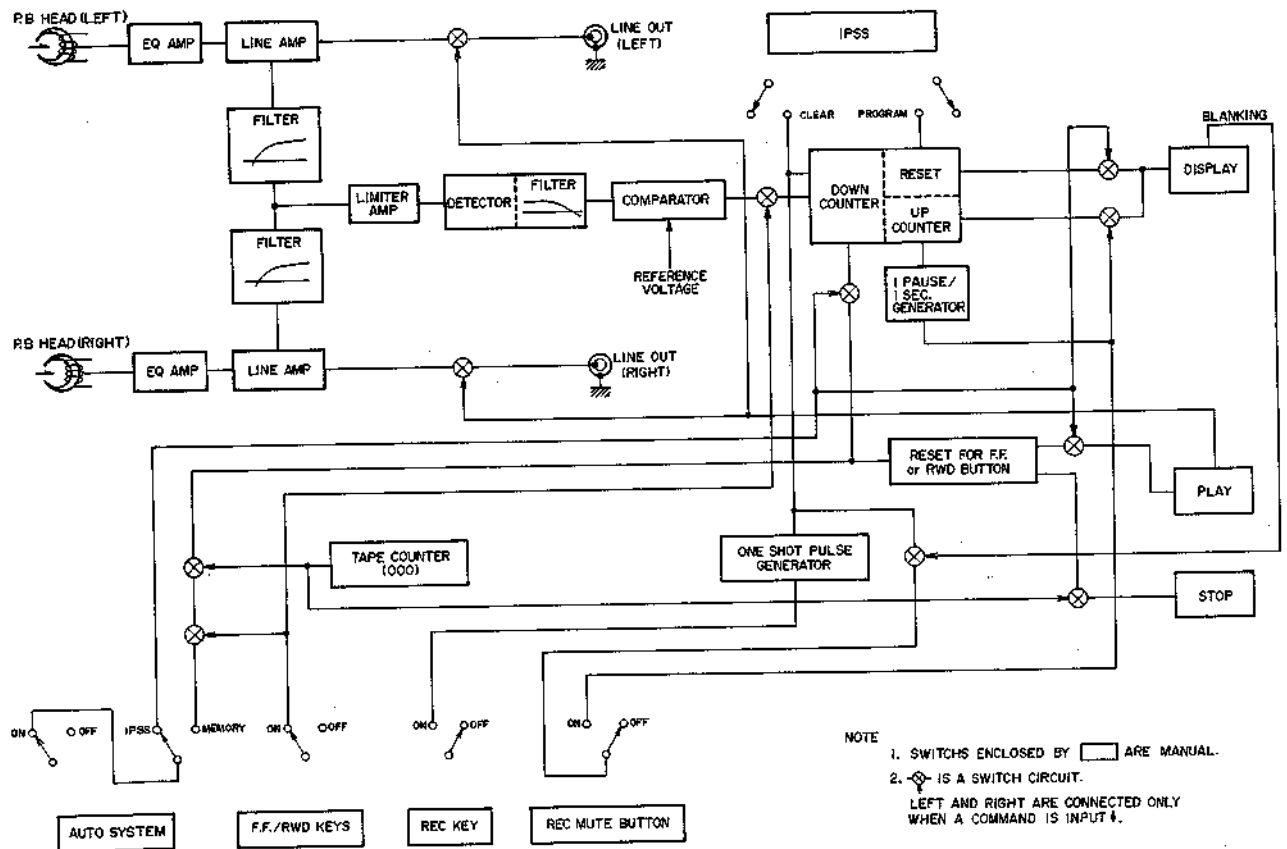

Fig. 5 IPSS/MEMORY SYSTEMS BLOCK DIAGRAM

1. IPSS (Instant Program Searching System) is the programming in advance of the song or songs (up to 9 from the present position on the tape) you want to listen to. When the FF or RWD and PLAY keys are depressed simultaneously, the no signal portion between songs is detected by the REC/PB head and the number of these is counted down according to the programmed number of songs. As it goes from 1 to 0, the FF or RWD key is released and it enters the Play mode.

2. CIRCUITRY DETECTING THE NO SIGNAL PORTION (Refer to Figs. 6, 7, & 8)

When the FF or RWD and PLAY keys are depressed simultaneously, the REC/PB contacts the tape and the signal on the tape is picked up by REC/PB head. The head is about 1.7 mm lower than it would be in the playback mode.

The picked up signal is added to input IC1-1 ② in the Limiter Amp., it is amplified, detected by D2 and added as TR1's base bias. TR1 is ON and IC1-2 ⑥ is practically earth potential. The standard voltage of the Comparator (IC1-2) is $1/2 V_{cc}$ (about 6V) so the output ⑦ becomes V_{cc} (about 12V).

When a no signal portion is reached, base bias is not added to TR1 and it is turned OFF. C3 charges and IC1-2 ⑦ becomes Low Level at the point that

IC1-2 ⑥'s potential exceeds the standard voltage ($1/2 V_{cc}$) in the comparator. As a result, charging current flows into C5 and a trigger pulse is generated at the cathode side of D14. IC2 counts down by this pulse's falling portion.

C2 and R5 are to compensate for the high frequency level drop caused by the head not touching the tape perfectly.

When there is noise in the portion between songs on the tape, there is more than one trigger pulse generated in the portion making miscounting a probability. C5's charged and discharged electricity are used to prevent this occurring.

C5 is charged through D3 and R56 while IC1-2 ⑦ is at Low Level (no signal portion between the songs on the tape) and both terminal's voltage difference is almost V_{cc} (+12V). When the no signal portion is over IC1-2 ⑦ becomes High Level and because it is piled on to the potential charged to C5, D14's cathode side's potential becomes higher than +B's (+12V) potential. Then C5 will discharge through R14 until both terminal's potentials are equal. Until C5 discharged down to a certain level even if IC1-2 ⑦ becomes Low Level, only a small trigger pulse is created in the D14 cathode side and does not reach the IC2's DOWN COUNT operation level. Therefore the programme counter does not count.

SYSTEM CONTROL PC BOARD CE-5206A

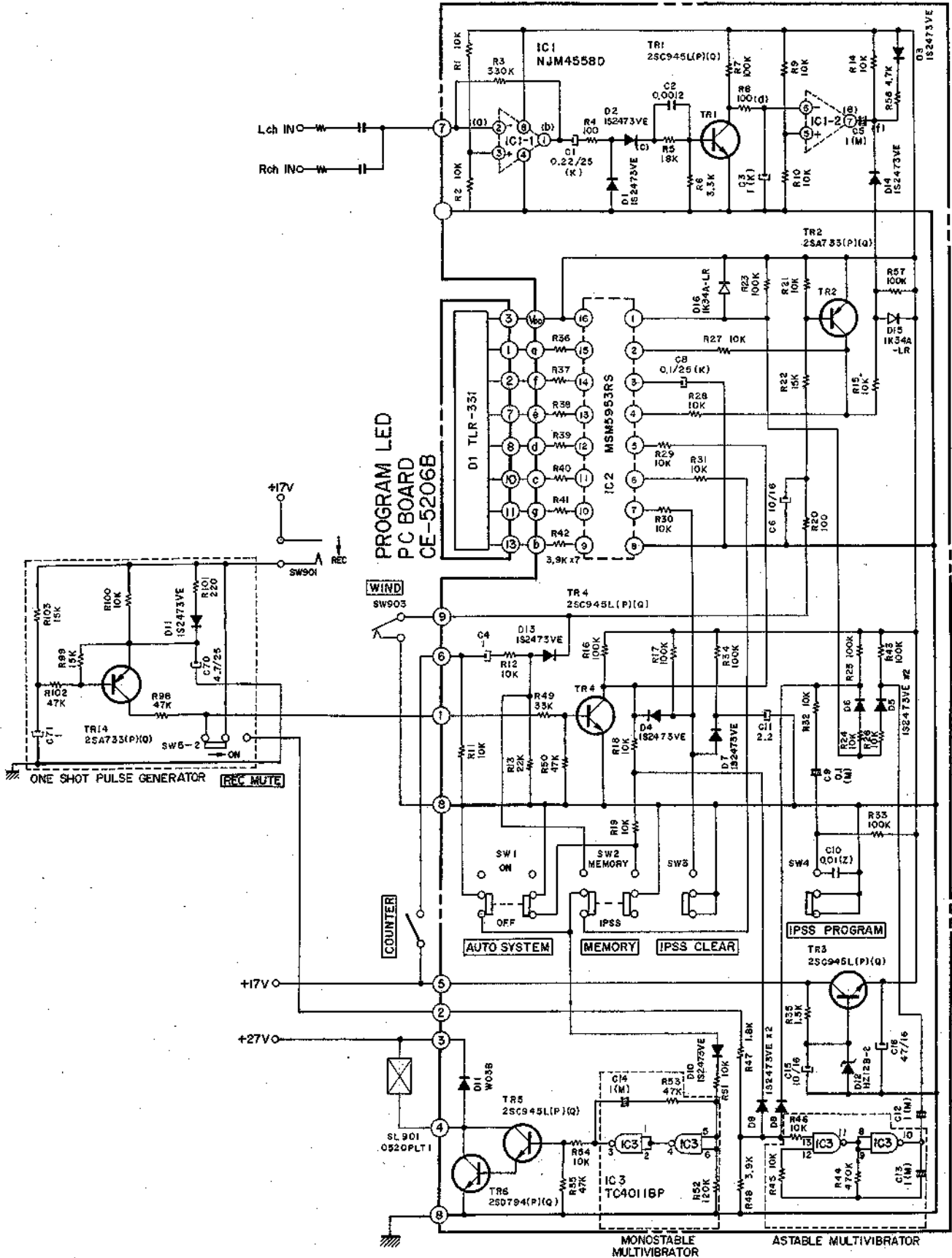

Fig. 6 IPSS/MEMORY SYSTEMS SCHEMATIC DIAGRAM

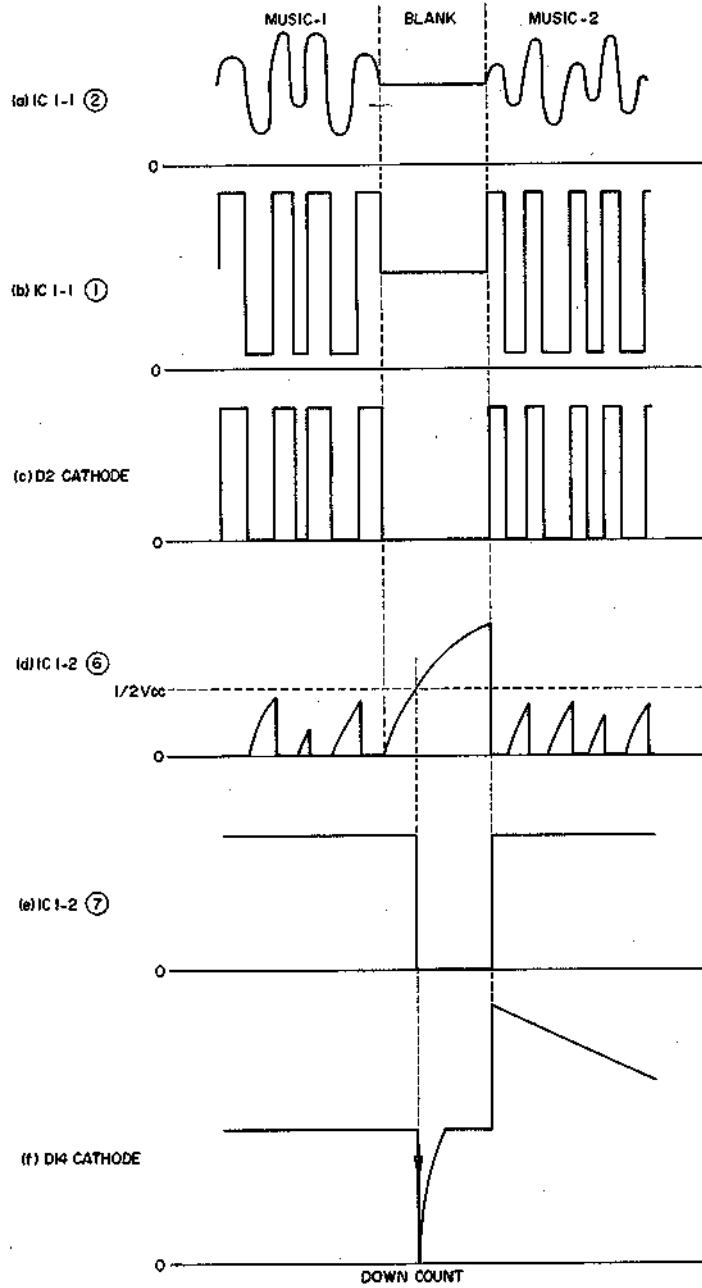

Fig. 7

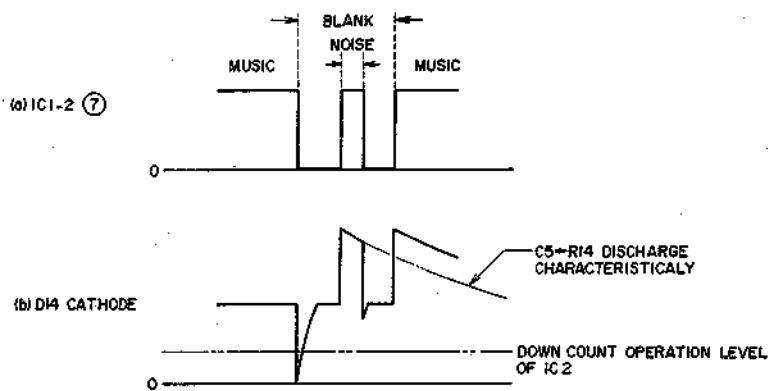

Fig. 8 When there is noise in the portion between songs on the tape

3. CIRCUIT CONSTRUCTION OF IC2 MSM 5953RS

Function BCD UP/DOWN COUNTER/7
 SEGMENT DECODER/DRIVER
Construction C MOS IC

1) Block Diagram

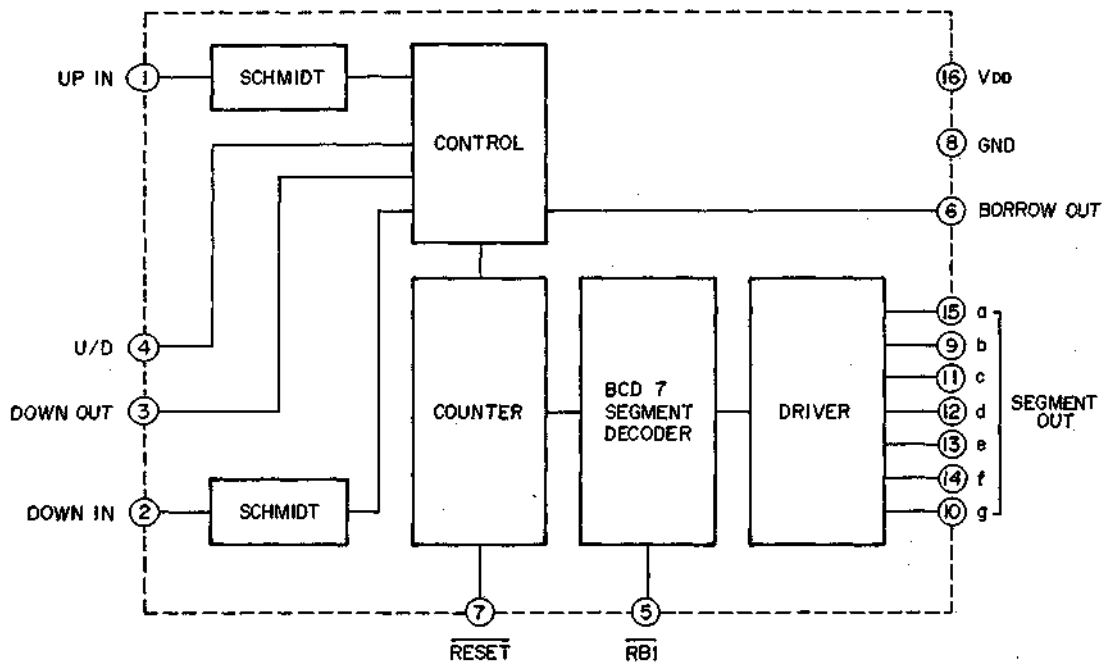







Fig. 9 MSM5953RS

2) Terminals and their functions

- UP IN:** Counts up (+1) using the raised portion of the pulse.
- DOWN IN:** Counts down (-1) using the falling portion of the pulse. Does not count at 0.
- DOWN OUT:** Outputs when there is DOWN IN input.
When a condenser is attached between this and GND, after input enters the DOWN IN terminal, the delayed time can be adjusted up until the counter counts down.
- U/D (UP/DOWN):** There is input to the DOWN IN terminal but counts down only when this terminal is Low Level.
- RBI (Ripple Blanking Input):** When put to Low Level the counter display (LED) is extinguished.
- BORROW OUT:** There is momentary output when there is DOWN input after the counter goes from 1 to 0, or from 0.
- RESET:** When put to Low Level the counter is reset to 0.
- 9 to 15 SEGMENT OUT:** Connects the Anode Common 7 Segment LED.
Light up when put to Low Level.

3) Function Table

RESET	U/D	DOWN IN	UP IN	COUNT CONDITION	COUNT
H	H	X		X	NO
H	H	X		X	UP COUNT (+1)
H	L	L		X	NO
H	L	L		X	UP COUNT (+1)
H	L		H	1 to 9	DOWN COUNT (-1)
H	L		H	0	NO
L	X	X	X	X	CLEAR (0)

X = Doesn't matter

Chart-1

U/D	COUNT CONDITION	BORROW OUT
H	X	L
L	1 to 9	L
L	0	H

X = Doesn't matter

Chart-2

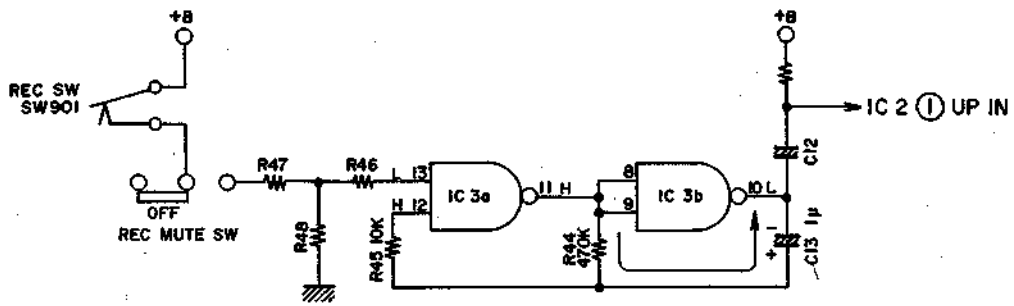

Fig. 10 Oscillation Stopped

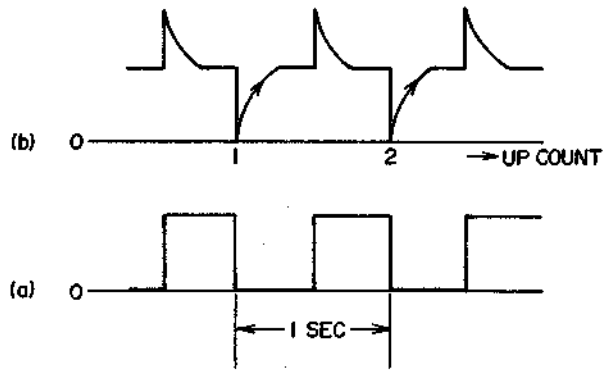
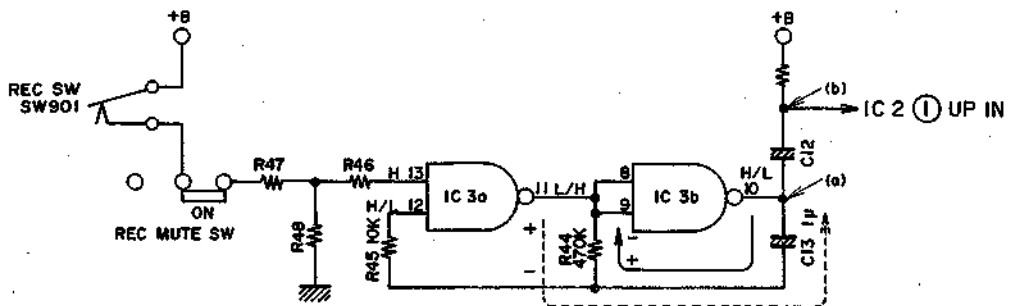

Fig. 11 Oscillation

4. OSCILLATOR CIRCUITRY FOR REC

TIME COUNT (Refer to Figs. 10 and 11)

This circuit is to indicate the Rec Mute Time Count in Program LEDs and to add one second interval pulses to the UP IN terminal of IC2.

When the Rec Mute button is not depressed, IC3a's input terminal ⑬ is "L" and IC3b's output terminal ⑩ is "L". C13 has been discharged as in Fig. 10 and IC3a's input terminal ⑫ is changed to "H" by this potential.

At this point, when the REC MUTE switch is depressed, IC3a's ⑬ changes to "H" IC3a's output terminal ⑪ to "L" and IC3b's ⑩ to "H". As IC3's ⑪ has become "L", C13 discharged through R44. During this discharging period (time constants of C13 and R44) IC3's ⑫ becomes "H" due to the voltage drop at both terminals of R44.

Once C13 has finished discharging, there is no current flowing in R44 and the voltage drop is 0 so IC3a's ⑫ changes to "L". As a result IC3a's ⑪ becomes "H", IC3b's ⑩ "L" and this time the charging current flows from IC3a's ⑪ through R44 to C13. During this charging period (Fixed time constants of R44 and C36) IC3a's ⑫ becomes "L".

After C36 has been charged, due to this potential, IC3a's ⑫, changes to "H", ⑪ to "L" and IC3b's ⑩ to "H". The above operation is repeated and a 1 Hz square wave appears at IC3b's output terminal ⑩

5. MONOSTABLE MULTIVIBRATOR

OPERATION (Refer to Fig. 6)

A plunger is activated by IC2's output ⑥ to release the FF or RWD key in the IPSS mode. However in IC2's output there is a pulse width which is too narrow to drive the transistor directly so the pulse width is enlarged by a Monostable vibrator, the transistor drive is corrected and then the plunger is activated.

6. ONE SHOT PULSE GENERATOR

(Refer to Fig. 6)

This circuit resets the counter for an instant when the REC key has been depressed while the REC Mute switch is being depressed.

When the REC key has been depressed after the REC Mute key, if TR14 has not been attached, TR4 turns off and the IC2 counter does not reset. If the counter is counting down numbers with the program switch these numbers will be increased by the time taken to depress the REC Mute switch. To prevent this, when the REC switch is put on TR14 is put on simultaneously for a certain period (the difference between C70's and C71's charging periods) of time only. When TR14 is turned on TR4 turns on and the counter is reset. Therefore the REC MUTE TIME indication begins from 0.

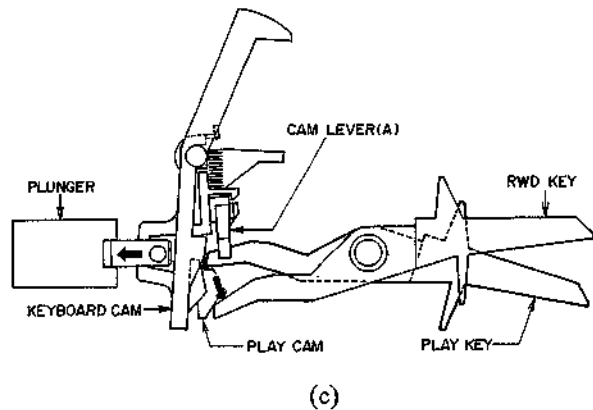
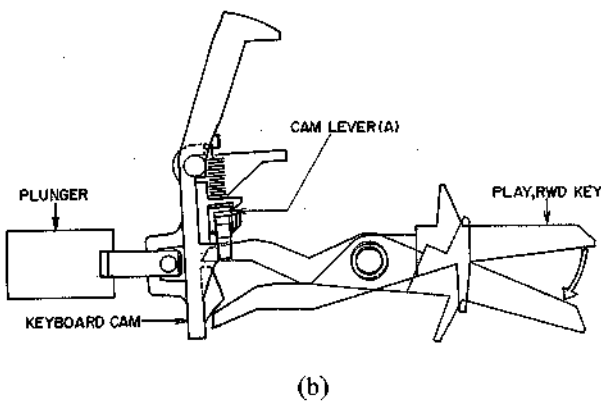
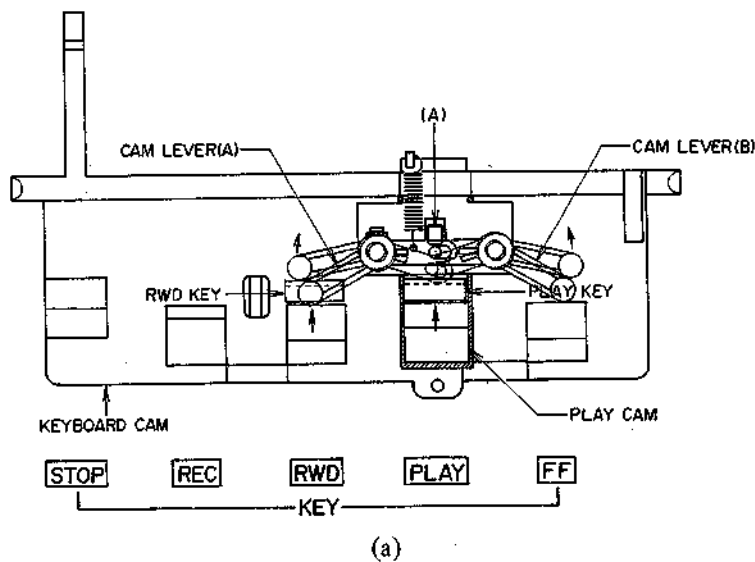



Fig. 12

7. DESCRIPTION OF KEYBOARD OPERATION (Refer to Fig. 12)

With IPSS and MEMORY operation the PLUNGER is activated and pulls the KEYBOARD CAM back. Only the FF or the RWD keys are released and the deck is put in the playback mode by the combination of the KEYBOARD CAM, the PLAY CAM and the CAM LEVERS (A) and (B).

The PLAY CAM and the KEYBOARD CAM are fixed by slotting CAM LEVERS (A) and (B) into section A of the KEYBOARD CAM. (Refer to Fig. 12a.)

Now in the IPSS mode, when the RWD and PLAY keys are depressed simultaneously, the RWD key attaches to the  section of the KEYBOARD CAM and the PLAY key to the  section of the PLAY CAM.

CAM LEVER (B) which is being held up with CAM LEVER (A) by the RWD key also moves in the direction of the arrow. (Fig. 12a, b)

CAM LEVERS (A) and (B) separate from the section A which is fixing the KEYBOARD CAM and the PLAY CAM so even if the KEYBOARD CAM is pulled backwards, PLAY CAM remains attached to the PLAY key and does not move backwards. Therefore even when the PLUNGER pulls the KEYBOARD CAM backwards because of the IPSS and MEMORY operation, the PLAY CAM does not move back with the result that only the RWD key is released and the deck goes in to the play mode. (Fig. 12c)

This will be the same when the FF key is depressed simultaneously with the PLAY key.

After the FF or RWD and PLAY keys have been depressed simultaneously, when the STOP key is depressed once only the FF or RWD key will be released so to release the PLAY key the STOP key must be depressed one more time. This is due to the operation outlined above.

VII. TIMER START SWITCH OPERATION

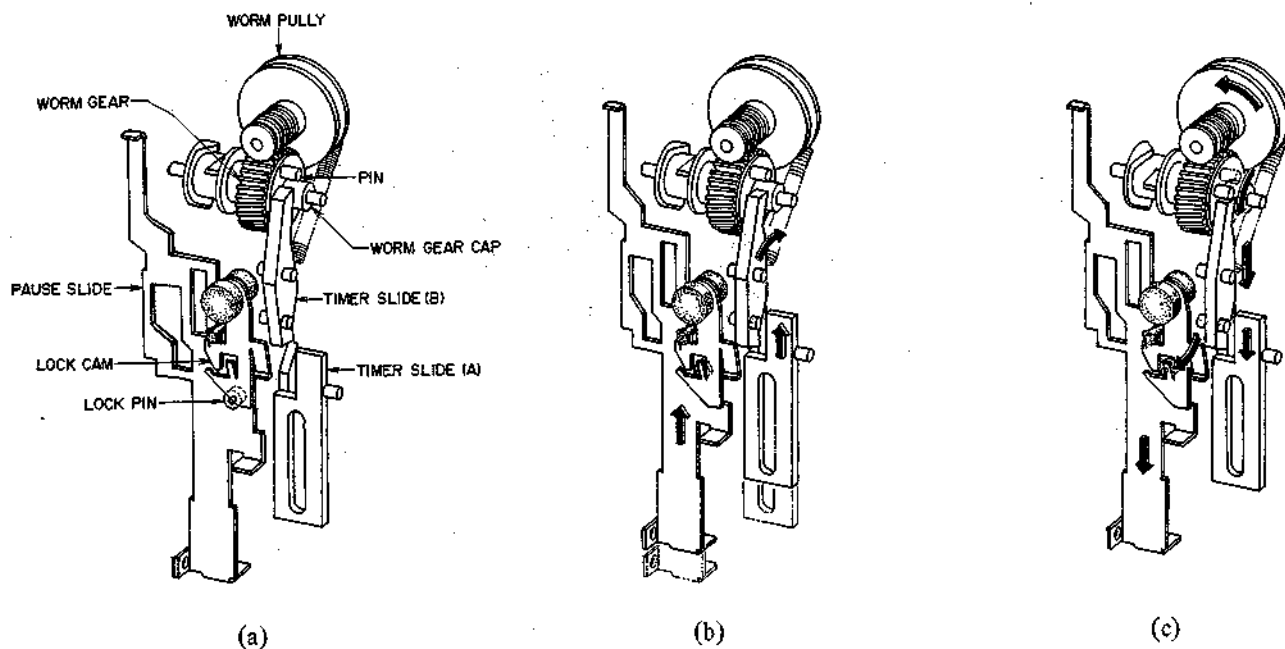

Fig. 13

The **TIMER START SWITCH** is designed to put the deck in the **REC** or **PLAY** modes by releasing the **PAUSE** key automatically (the **PAUSE**, **REC** and **PLAY** keys have already been depressed) when the power is turned on by the timer.

In the **PAUSE** mode, the **PAUSE SLIDE** is lifted up and fixed by attaching the **LOCK PIN** to the **LOCK CAM** so to release the **PAUSE** mode all you have to do is to detach the **LOCK PIN** from the **LOCK CAM**.

When put into the **PAUSE** mode, the **LOCK PIN** is attached to the **LOCK CAM** and the **PAUSE SLIDE** is locked. When the **TIMER START SWITCH** is put on **TIMER SLIDE (A)** moves upwards and as a result, **TIMER SLIDE (B)** moves upwards to the inside in the direction of the arrow and downwards to the outside. See Fig. 13b.

If the power switch is turned on here, the **WORM PULLEY** and the **WORM GEAR** revolve. The pin on the **WORM GEAR CAP** moves in the direction of the arrow **TIMER SLIDE (B)** is pushed down so the **LOCK CAM** is pushed upwards by this section. Then the **LOCK PIN** is detached, the **PAUSE SLIDE** lowers and the **PAUSE** key is released. The **TIMER START SWITCH** is also released because **TIMER SLIDE (A)** is pushed down by **TIMER SLIDE (B)**.

VIII. AUTO STOP MECHANISM OPERATION

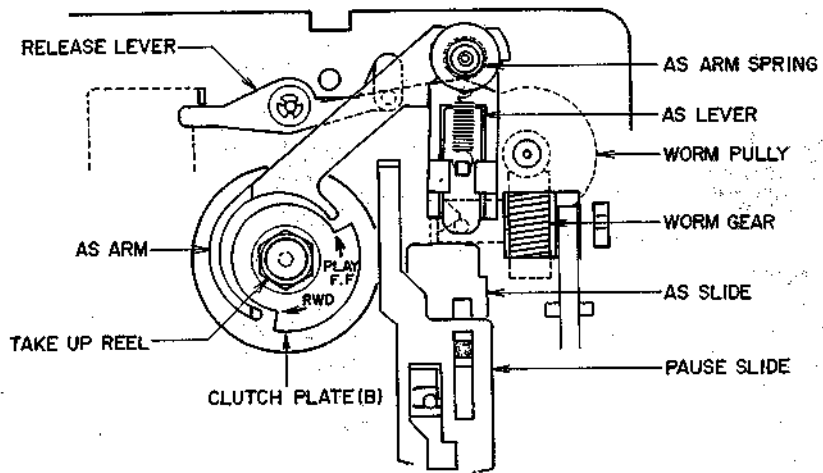

Fig. 14

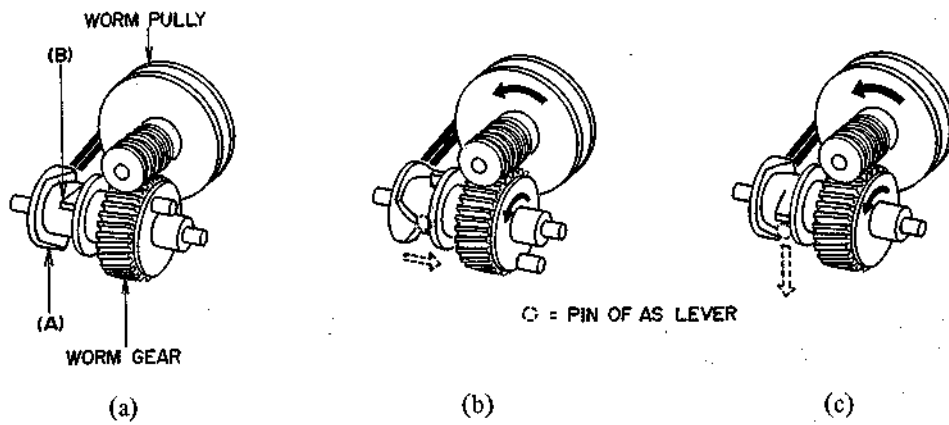

Fig. 15

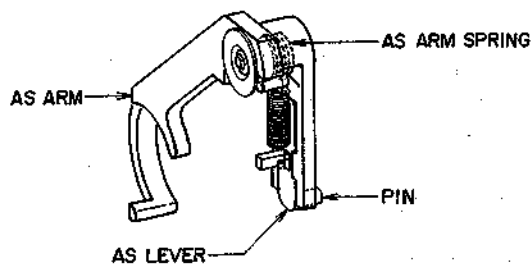

Fig. 16



AUTO STOP puts the deck into the STOP mode by releasing the keys when the end of the tape is reached in the PLAY, FF, RWD REC/PB modes.

1. HOW EACH PART OPERATES

a. CLUTCH PLATE (B) (Fig. 14)

There is felt attached to this and friction force is generated (Shown by the arrow) and it seems as if it is pushing the AS ARM outwards.

b. AS LEVER (Figs. 14, 16)

The pin attached to the rear of the AS LEVER enters the groove of the WORM GEAR. It touches against the  section a as the WORM GEAR revolves and moves to the left or right or is pushed down by  section B.

c. RELEASE LEVER (Fig. 14)

Adds the same friction force to the AS ARM by pulling down the AS ARM Spring in the pause mode as when the reel revolves.

2. When put into the PLAY (FF, RWD) mode the fly-wheel revolves and the WORM pulley and WORM gear revolves. The reel revolves and the CLUTCH PLATE goes to push the AS ARM outwards with the friction force so the pin at the rear of the AS LEVER receives this force to the left then it contacts the ridged section  A of the WORM GEAR and move to the left and right.

At the end of the tape, the reel stops revolving so the friction disappears. In the PLAY (FF, RWD) mode the RELEASE LEVER drops so friction is not added to the AS ARM from the AS ARM SPRING.

The Worm Lever continues to revolve and the AS LEVER pin is taken up to the top of the ridged  section where it then stops.

It is then pushed down by the WORM GEAR section B , and pushes down the AS SLIDE with the AS LEVER and releases the PLAY (FF, RWD) keys. When the PAUSE key is depressed from the PLAY mode the reel stops revolving and the force from the CLUTCH PLATE to the AS ARM stops. However the PAUSE SLIDE moves upwards and pushes up the RELEASE LEVER which had been held down so the same force is applied as to the AS ARM by the AS ARM SPRING so AUTO STOP does not operate.

IX. MECHANISM ADJUSTMENT

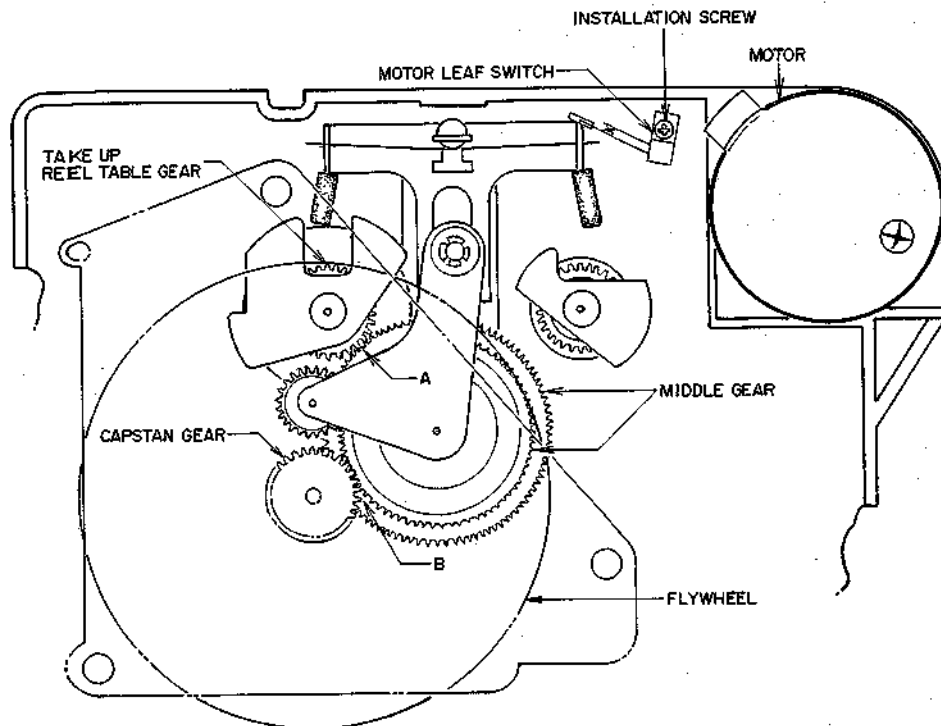

Fig. 17 Motor Leaf Switch Timing Adjustment

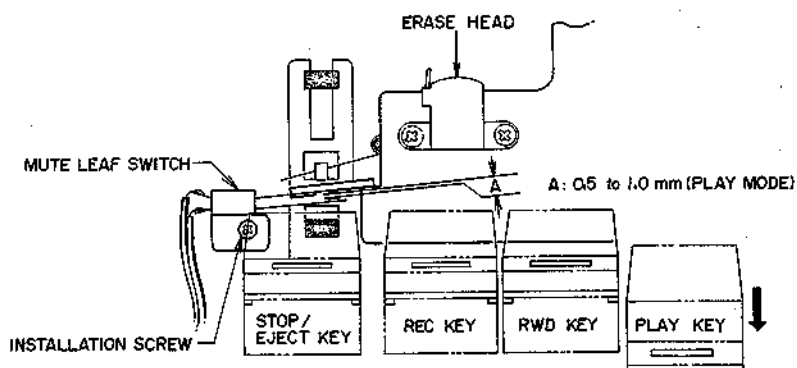

Fig. 18

1. MOTOR LEAF SWITCH TIMING ADJUSTMENT (Refer to Fig. 17)

The FF key has been depressed and when the capstan gear turns before points A and B gears are engaged, they screech because the middle gear which was engaged springs off. Adjust the timing of the motor revolutions to prevent this.

Gently depress the FF key and adjust the installation position of the motor leaf switch until the motor's switch is activated after the points A and B gears have been engaged slightly.

2. MUTE LEAF SWITCH INSTALLATION POSITION ADJUSTMENT (Refer to Fig. 18)

When in the playback mode, the space A should be 0.5 to 1.0 mm as in Fig. 18. To adjust, turn the leaf switch installation screw.

Confirm the switch stays in the same position when the FF and PLAY or RWD and PLAY keys are depressed together.

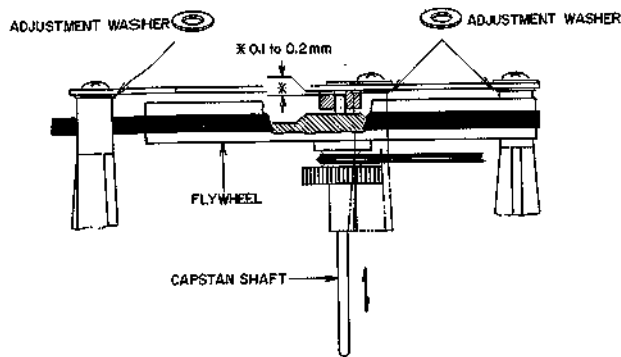

Fig. 19

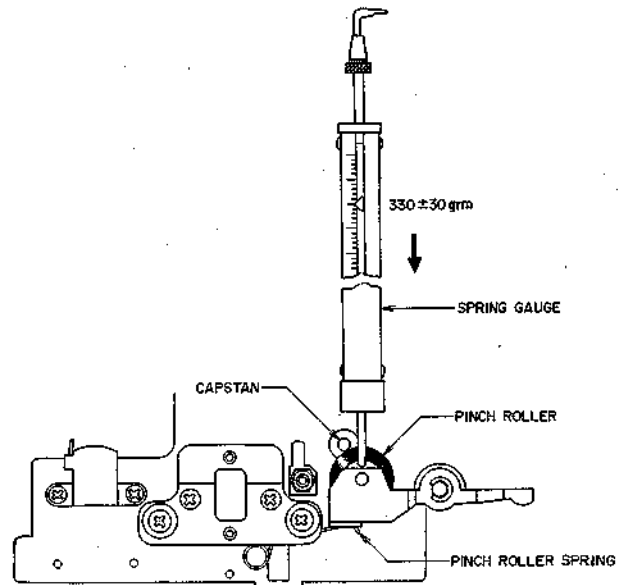

Fig. 20

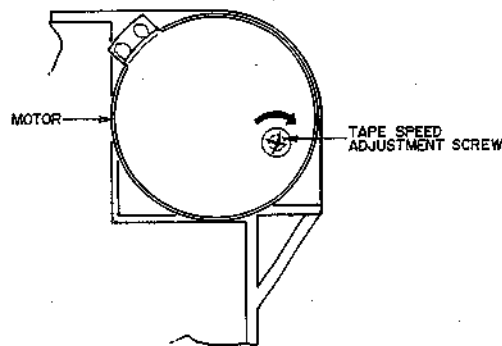

Fig. 21

3. FLYWHEEL LOOSE PLAY

ADJUSTMENT (Refer to Fig. 19)

Insert the various washers in the three places between the prop and the flywheel hold plate and adjust to give 0.1 to 0.2 mm loose play when the flywheel is moved in the direction of the arrows.

4. PINCH ROLLER PRESSURE

MEASUREMENT (Refer to Fig. 20)

At playback mode, push the pinch roller with a spring gauge until the pinch roller separates from the capstan by about 1 mm to 2 mm and then gently return. Take a reading of the spring gauge indication at the moment the pinch roller touches the capstan and begins to rotate

Specified Pinch Roller Pressure : 330 ± 30 gm

In case specified pressure cannot be attained, replace the pinch roller spring.

5. WINDING TORQUE MEASUREMENT

IN EACH MODE

Insert cassette torque meter and measure in each mode.

For fast forward and rewind measure at the end of the tape when the tape has stopped running.

The specified torque is:

Playback : 35 to 60 g-cm

Fast Forward, Rewind : 80 to 120 g-cm

In case specified take-up torque cannot be attained.

Playback mode : Replace Take-up Reel Table Block.

Fast Forward of Rewind mode :

Replace Middle Gear Block.

6. TAPE SPEED ADJUSTMENT

(Refer to Fig. 21)

Connect the frequency counter to the line output terminals. Playback a 1,000 Hz pre-recorded test tape and adjust tape speed adjustment screw to obtain a tape speed of $1,000 \text{ Hz} \pm 1\%$.

X. HEAD ADJUSTMENT

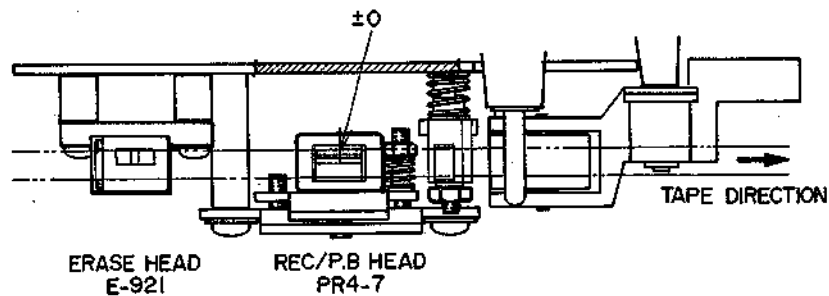
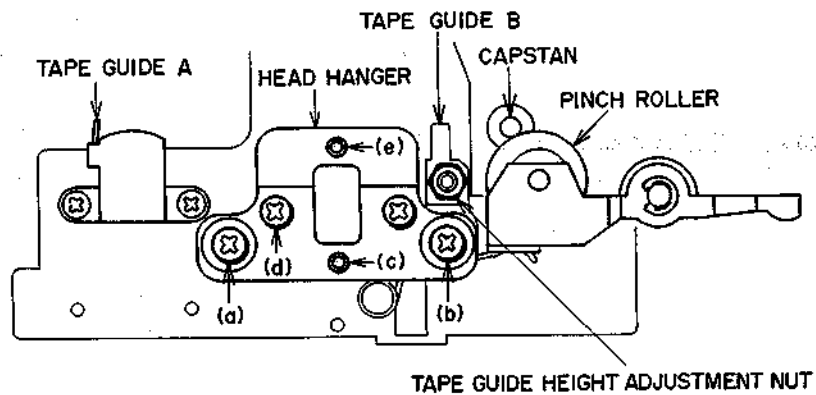

Fig. 22. Head Adjustment

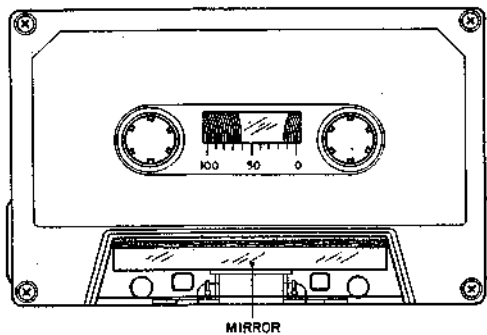

Fig. 23. Mirror Cassette

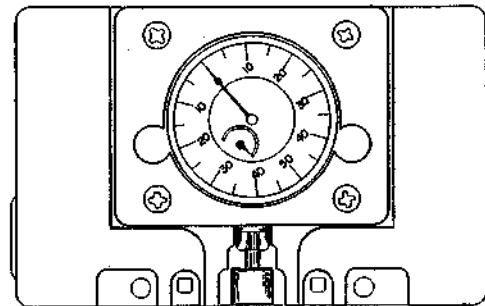

Fig. 24. AKAI Head Projection Gauge

1. TAPE GUIDE HEIGHT ADJUSTMENT

(Refer to Figs. 22, 23)

- 1) When using an ordinary cassette, the tape guides and heads, etc. are not visible. As shown in Fig. 23 use a cassette tape from which part of the cassette case has been cut out and a mirror installed for easy visibility of the head area when making tape guide height adjustment.
- 2) At playback mode, using the tape guide (A) shown in Fig. 22 as standard for height, adjust tape guide (B) height with tape guide height adjustment nut so that the tape runs smoothly and does not catch on the tape guides.

2. REC/PB HEAD PROJECTION

ADJUSTMENT

Set the AKAI Head Projection Gauge (Fig. 24) and adjust (a) and (b) screws (Fig. 22) so that it reads: 1.9 to 2.2 mm in the IPLS Mode, 3.55 ± 0.1 mm in the Play Mode.

NOTE: Raise or lower by exactly the same amount the head hanger's left and right and adjust so that the head does not lean to the left or right.

3. RECORDING/PLAYBACK HEAD HEIGHT ADJUSTMENT (Refer to Figs. 22, 23)

- 1) Utilize the cassette tape used in Tape Guide Height Adjustment above, and playback the leader tape part of cassette tape.
- 2) As shown in Fig. 22, adjust head height with screws (c), (d) and (e) until the upper edge of the tape is the same height as the upper edge of the left channel REC/PB head core.
- 3) After completing adjustment step 2), playback the Head Height Adjustment tape (4 track, 1,000 Hz) and adjust Head Height Adjustment screws (c), (d), (e) to put the output power from both channels to maximum.

4. RECORDING/PLAYBACK HEAD AZIMUTH ALIGNMENT ADJUSTMENT (Refer to Fig. 22)

- 1) Playback a 10 kHz pre-recorded cassette azimuth alignment test tape and adjust screw (d) shown in Fig. 22 to obtain maximum output on both channels.
- 2) Invert cassette and confirm that the output level does not change from that obtained in Item 4-1) above. If the output level differs, adjust in the same way as in Item 4-1) above until both sides of the test tape display equal output.
- 3) After adjustment, better to check again head height and azimuth alignment.

NOTES:

1. Be sure to clean the heads prior to head adjustment.
2. Be careful not to use a magnetized driver or other magnetized tools in the vicinity of the heads.
3. Be sure to demagnetize the heads with a Head Demagnetizer before and after head adjustment.
4. When a mirror installed cassette test tape as shown in Fig. 24 is required, it can be ordered from AKAI Electric Co.

XI. AMPLIFIER ADJUSTMENT

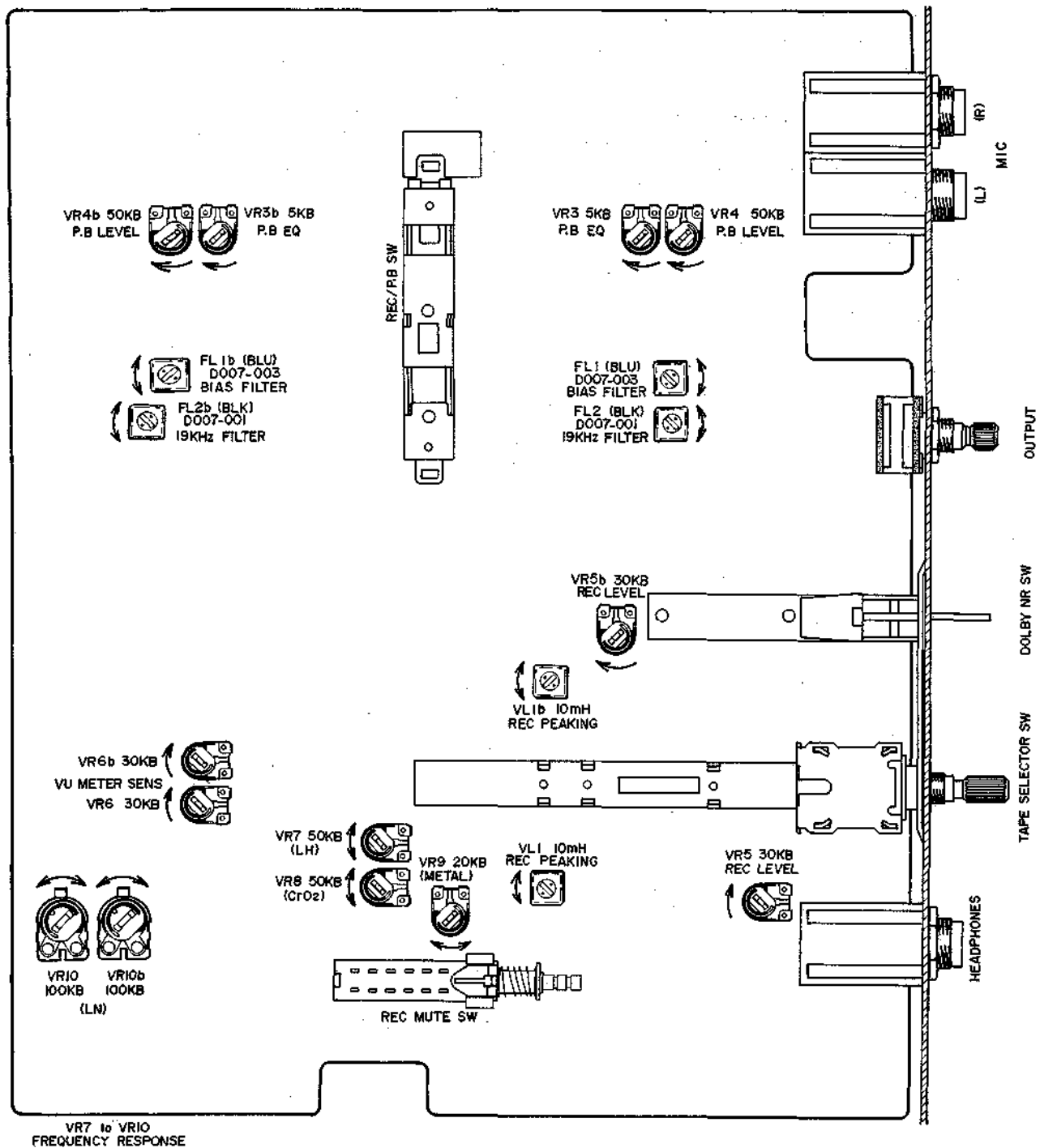

Fig. 25 Pre Amp P.C Board CE-5201A

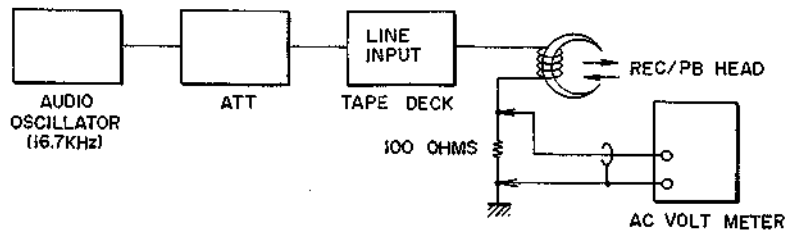

Fig. 26 Instruments Connection

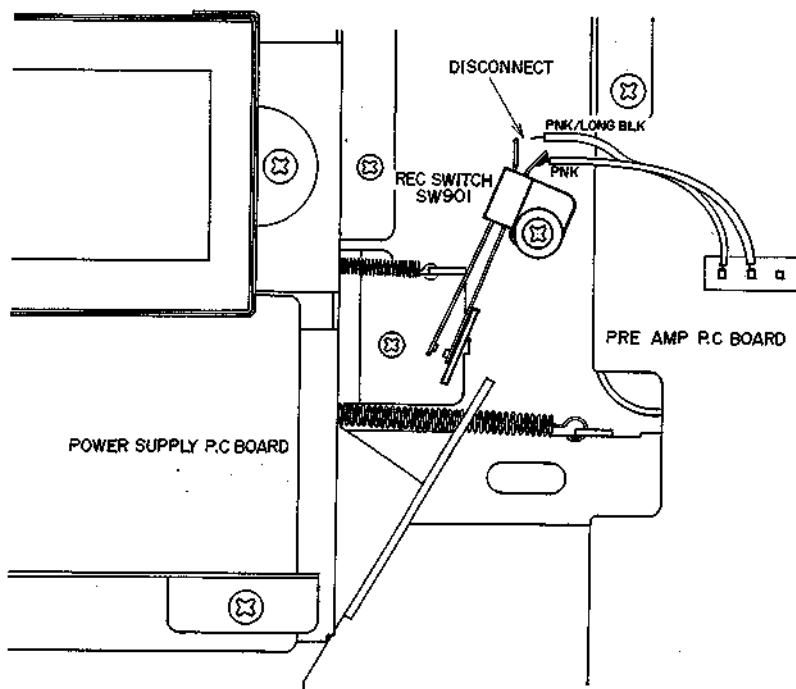
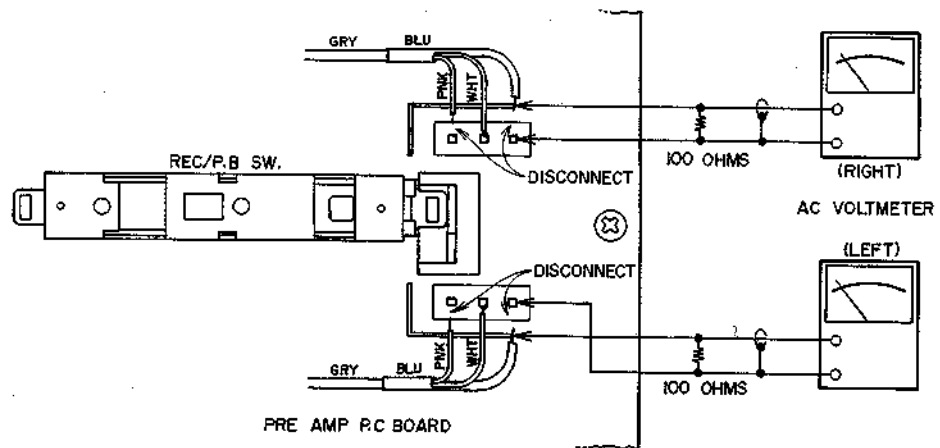

Fig. 27 Rec Peaking Adjustment

Step	Adjustment Item	Test Tape Supply Signal	Mode	Adjustment Point	Result	Remarks
1	Playback Level	333 Hz, 0 VU Test Tape	PB	VR 4 50 kB	-5.5 ± 0.5 dBm (410 mV)	
2	Bar Meter Sensitivity	1,000 Hz -5.5 dBm from oscillator	REC	VR 6 30 kB	0 VU indication	
3	Playback Equalizer	10 kHz Test Tape	PB	VR 3 5 kB	-19.0 ± 0.5 dBm	
4	Rec Peaking adjustment	16.7 kHz -25.5 dBm from oscillator	REC	VL 1 10 mH	AC Voltmeter indicates to maximum	Tape selector to LN. See the Figs. 25, 26, 27. NOTES 7, 10
5	LN Position Frequency Response	Low Noise Blank tape. 1,000 Hz 10,000 Hz -25.5 dBm recording	REC/PB	VR 10 100 kB	1,000 Hz to 10,000 Hz flat	
6	LH Position Frequency Response	LH Blank tape 1,000 Hz 10,000 Hz -25.5 dBm recording	REC/PB	VR 7 50 kB	1,000 Hz to 10,000 Hz flat	Set tape selector to LH Position
7	CrO ₂ Position Frequency Response	CrO ₂ Blank tape 1,000 Hz 10,000 Hz -25.5 dBm recording	REC/PB	VR 8 50 kB	1,000 Hz to 10,000 Hz flat	Set tape selector to CrO ₂ Position
8	Metal Position Frequency Response	Metal Blank tape 1,000 Hz 10,000 Hz -25.5 dBm recording	REC/PB	VR 9 20 kB	1,000 Hz to 10,000 Hz flat	Set tape selector to Metal Position
9	Recording Level	LN Blank tape 1,000 Hz -5.5 dBm recording	REC/PB	VR 5 30 kB	-5.5 ± 0.5 dBm	Set the Mic Volume to Minimum
10	Distortion Factor Confirmation	1,000 Hz -5.5 dBm recording	REC/PB		LN < 0.8% LH < 0.8% CrO ₂ < 0.7% Metal < 0.6%	NOTE 8
11	Bias Filter	No signal input	REC	FL 1 D07-003	AC Voltmeter indicates to minimum	Set tape selector to Metal Position Set REC Volume to Maximum. NOTE 10
12	19 kHz Filter adjustment	19 kHz from oscillator	REC	FL 2 D07-001	AC Voltmeter indicates to minimum	Set Dolby NR Switch to ON, filter ON Position. NOTES 9, 10

Chart-3

-
- NOTES:**
1. The Output Level Control should be at maximum.
 2. Input selector switch to LINE.
(The JPN, AAL Models do not have this facility.)
 3. Because each of these adjustments is vital to perfect Dolby NR circuit operation, ensure that they are carried out with as few errors as possible.
 4. Except for Step 6 thru 8 and 10, set Tape Selector to LN Position.
 5. Except for Step 12, set Dolby NR switch to OFF Position.
 6. Use the following cassette measuring tapes:

LN tape	:	TDK	LN2	C-60
LH tape	:	Maxell	UD	C-60
CrO ₂ tape	:	TDK	SA	C-60
Metal tape	:	TDK	MA-C	C-60
 7. Stop the recording bias oscillator while making record peaking adjustment (Refer to Fig. 27).
 8. If it does not comply with the specifications, repeat Steps 5 to 9 and readjust.
 9. Adjust the oscillator's frequency to give a frequency counter reading of 19.00 kHz.
 10. Unless the core is moved unintentionally this adjustment is not necessary.

XII. DC RESISTANCE OF VARIOUS HEADS

Parts	Designation	DC Resistance
REC/PB Head	PR4-7	650 ohms \pm 10%
Erase Head	E-921	1.6 ohms \pm 20%

Chart-4

XIII. CLASSIFICATION OF VARIOUS P.C BOARDS

1. P.C BOARD TITLES AND IDENTIFICATION NUMBERS

P.C Board Title	P.C Board Number
Pre Amp P.C Board	CE-5201A
Sys. Con P.C Board	CE-6206A
Power Supply P.C Board (U/T)	CE-5202
Power Supply P.C Board (CEE, UK, SAA)	CE-5203
Power Supply P.C Board (CSA, AAL)	CE-5204
Power Supply P.C Board (JPN)	CE-5205
Meter P.C Board	CE-5209
Volume P.C Board	CE-5201C
Program LED P.C Board	CE-5206B
LED P.C Board	CE-5201B
Lamp P.C Board	CE-1078

Chart-5

2. COMPOSITION OF VARIOUS P.C BOARDS

1) PRE AMP P.C BOARD CE-5201A (3ED), VOLUME P.C BOARD CE-5201C & LED P.C BOARD CE-5201B

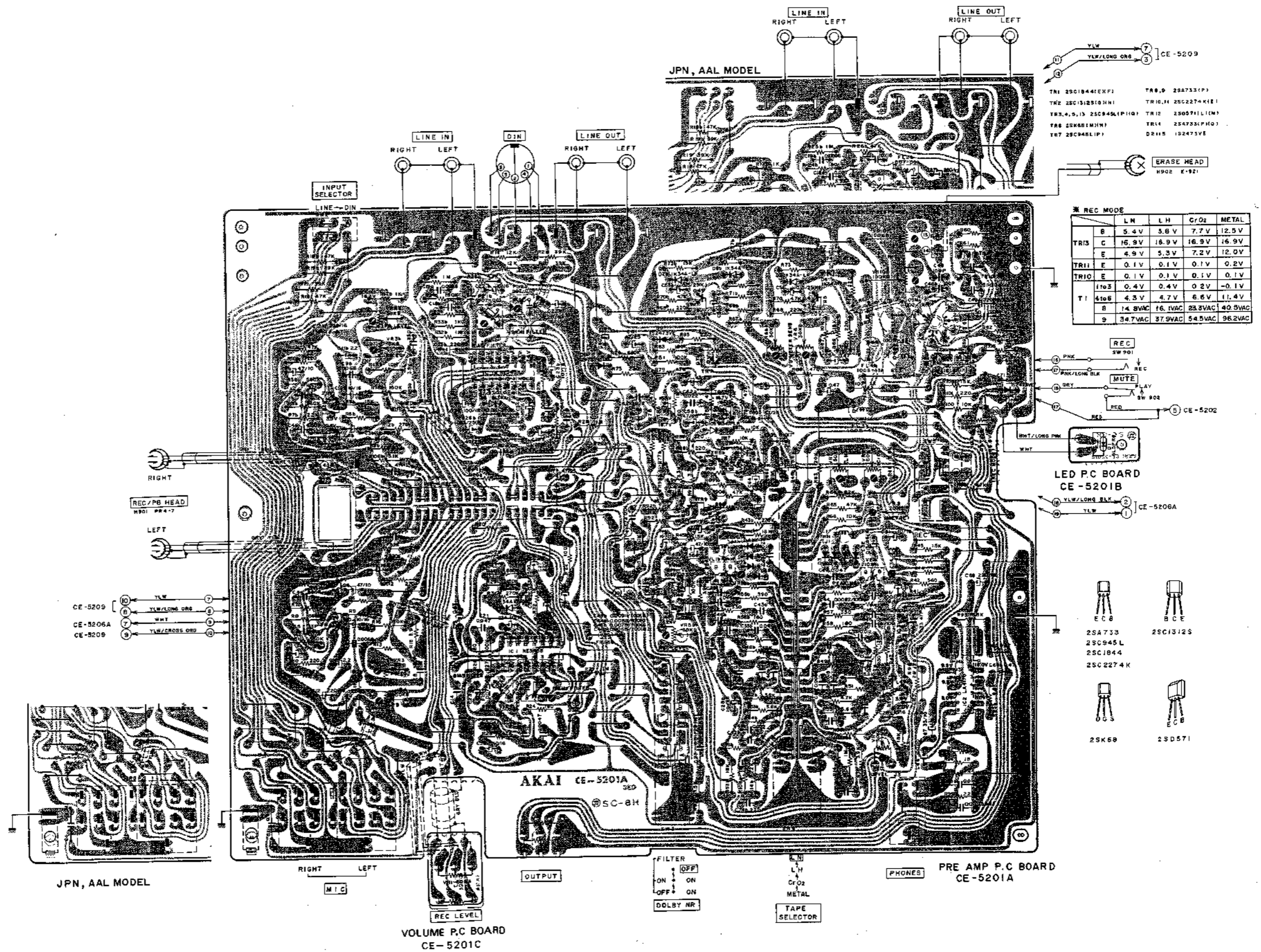

2) SYS. CON P.C BOARD CE-5206A (2ED) & PROGRAM LED P.C BOARD CE-5206B

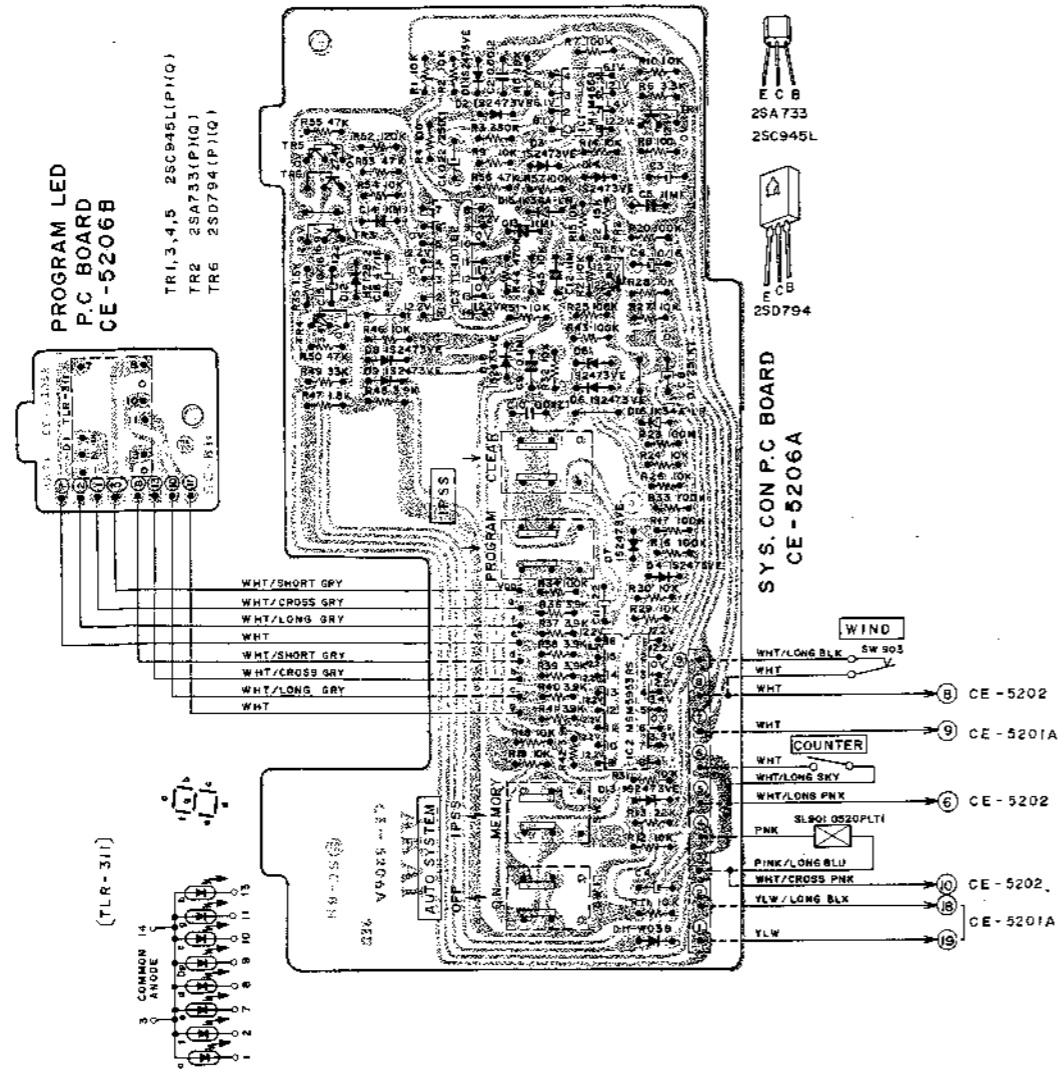

3) METER P.C BOARD CE-5209

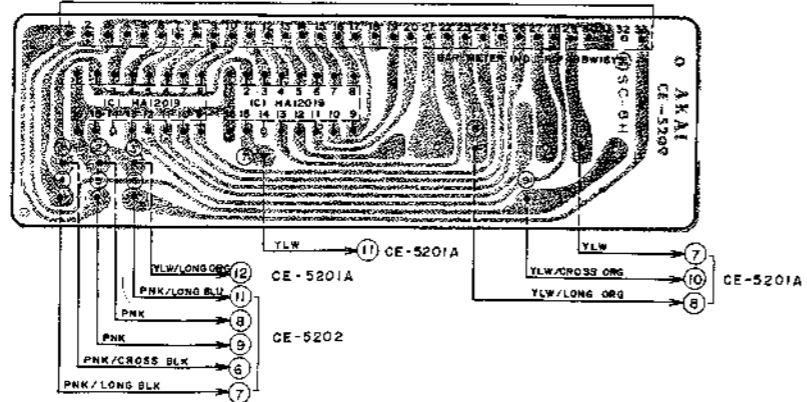

4) POWER SUPPLY P.C BOARD (U/T) CE-5202 (2ED) & LAMP P.C BOARD CE-1078

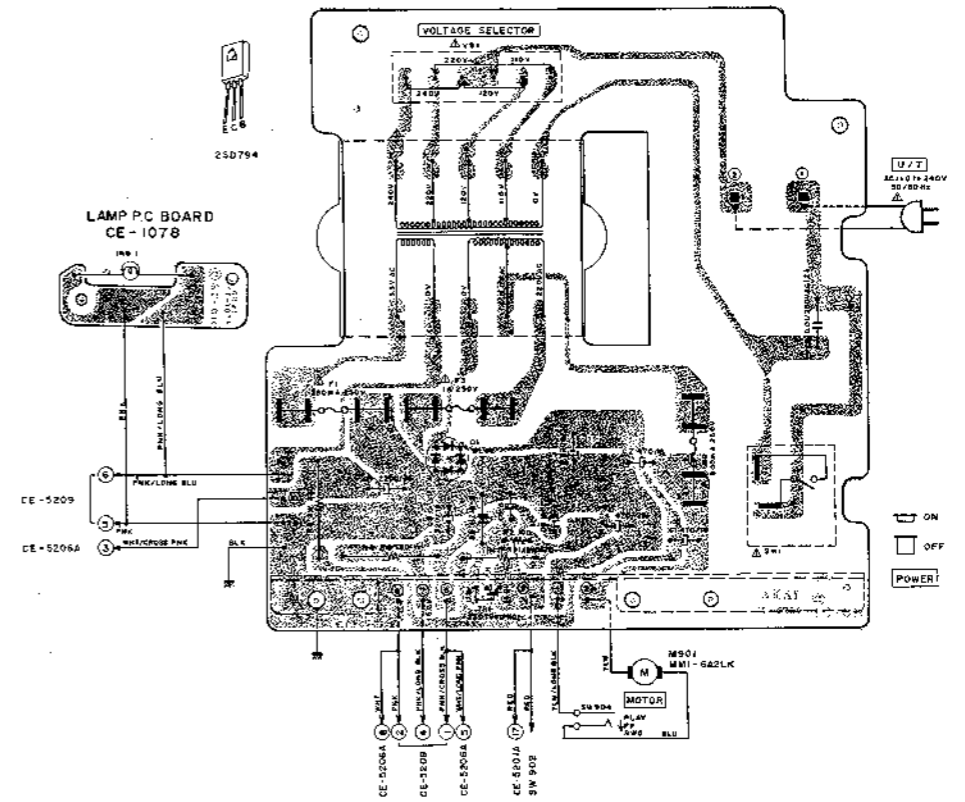

5) POWER SUPPLY P.C BOARD (JPN) CE-5205 (2ED)

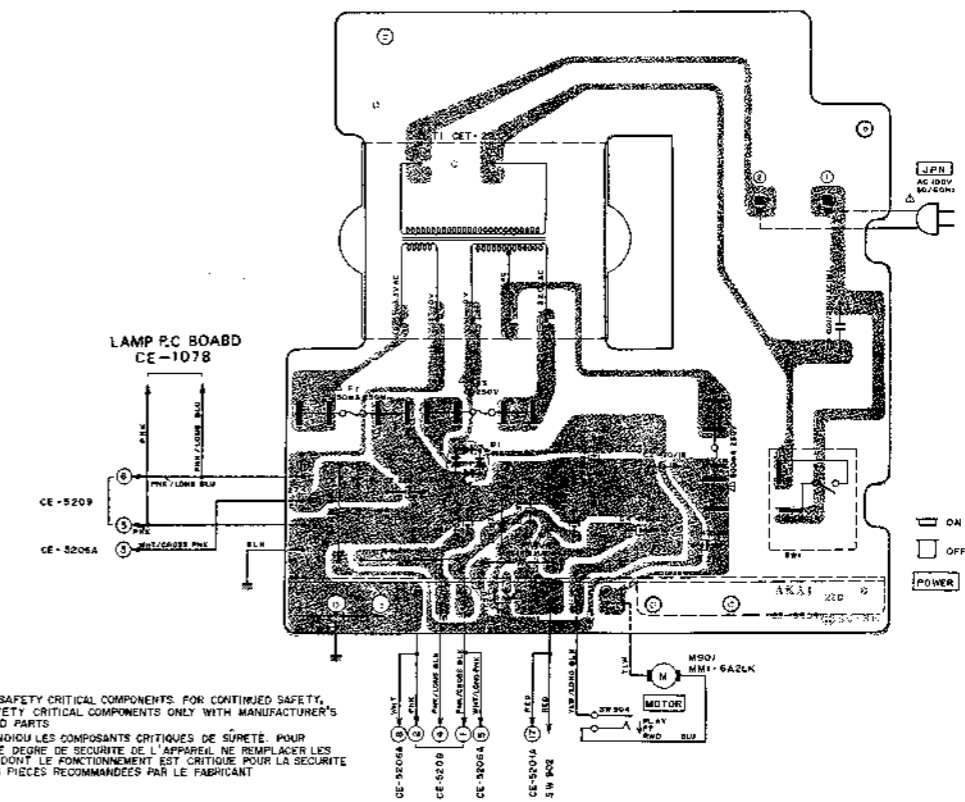

WARNING: Δ INDICATES SAFETY CRITICAL COMPONENTS. FOR CONTINUED SAFETY, REPLACE SAFETY CRITICAL COMPONENTS ONLY WITH MANUFACTURER'S RECOMMENDED PARTS.
 AVERTISSEMENT: Δ IL INDIQUE LES COMPOSANTS CRITIQUES DE SÛRETÉ. POUR MAINTENIR LE DEGRÉ DE SÛRETÉ DE L'APPAREIL, NE REMPLACER LES COMPOSANTS QU'AVEC LES COMPOSANTS RECOMMANDÉS PAR LE FABRICANT.

6) POWER SUPPLY P.C BOARD (CSA, AAL) CE-5204 (2ED)

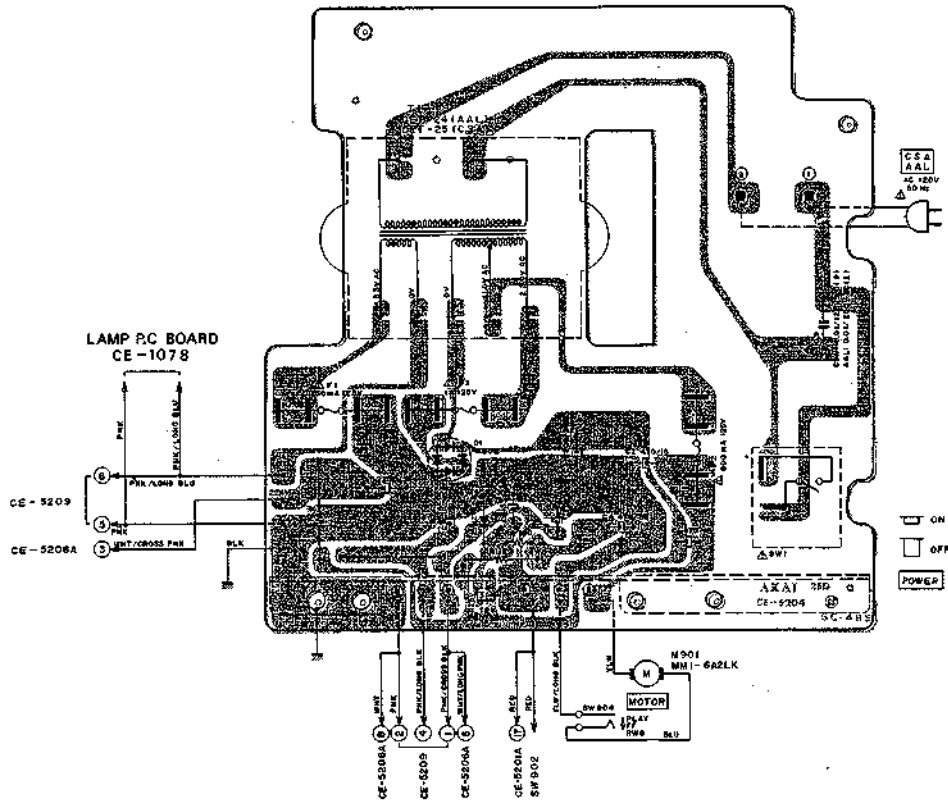

7) POWER SUPPLY P.C BOARD (CEE, UK, SAA) CE-5203 (2ED)

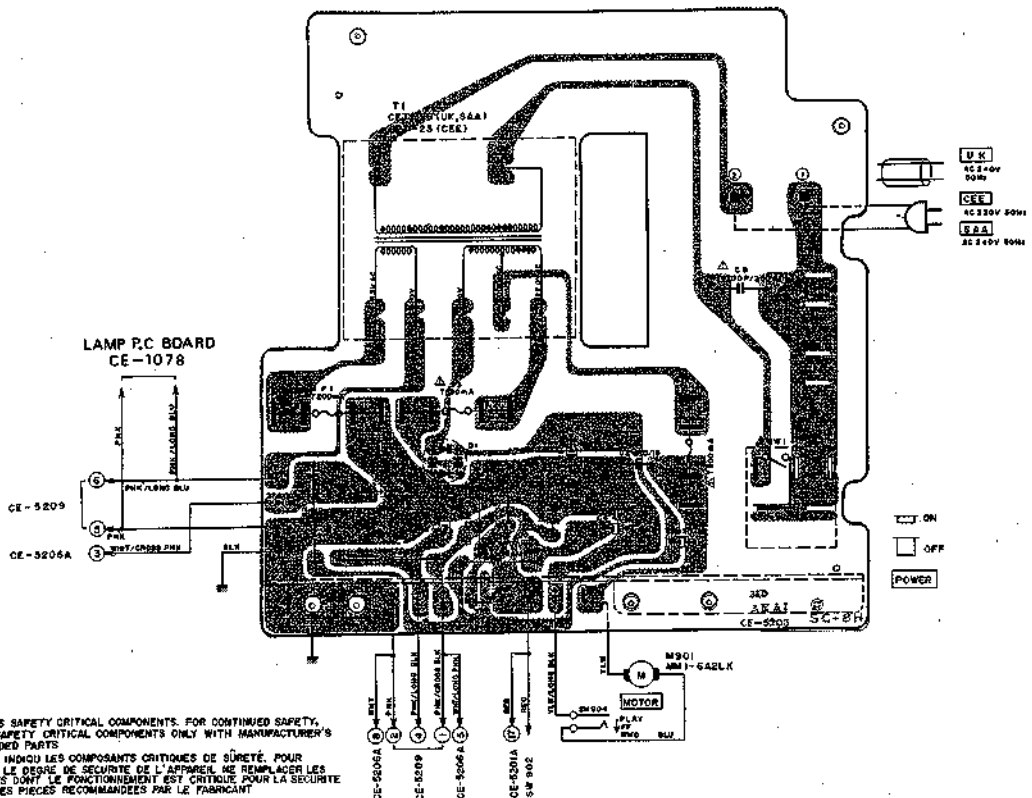

WARNING: INDICATES SAFETY CRITICAL COMPONENTS. FOR CONTINUED SAFETY,
REPLACE SAFETY CRITICAL COMPONENTS ONLY WITH MANUFACTURER'S
RECOMMENDED PARTS

AVERTISSEMENT: A IL INDIQUÉ LES COMPOSANTS CRITIQUES DE SÛRETÉ. POUR
MAINTENIR LE DEGRÉ DE SÛRETÉ DE L'APPAREIL, NE REMPLACER LES
COMPOSANTS DONT LE FONCTIONNEMENT EST CRITIQUE POUR LA SÛRETÉ
QUE PAR DES PIÈCES RECOMMANDÉES PAR LE FABRICANT

MEMO

MEMO

MEMO

SECTION 2

PARTS LIST

TABLE OF CONTENTS

1.	RECOMMENDED SPARE PARTS LIST	38
2.	HEAD BLOCK	40
3.	MECHA ASSEMBLY BLOCK (1)	41
4.	MECHA ASSEMBLY BLOCK (2)	42
5.	PRE AMP (NEW) P.C BOARD (CE-5201A) BLOCK	44
6.	SYS CON (NEW) P.C BOARD (CE-5206A) BLOCK	45
7.	POWER SUPPLY (A/B) P.C BOARD (CE-5202/5205) BLOCK	45
8.	BAR METER P.C BOARD (CE-5209) BLOCK	45
9.	ASSEMBLY BLOCK	46
10.	FINAL ASSEMBLY BLOCK	48
	INDEX	50

Resistor and Capacitor which is not listed in this parts list, please refer to COMMON LIST FOR SERVICE PARTS.

HOW TO USE THIS PARTS LIST

1. This parts list is compiled by various individual blocks based on assembly process.
2. When ordering parts, please describe parts number, serial number, and model number in detail.
3. How to read List

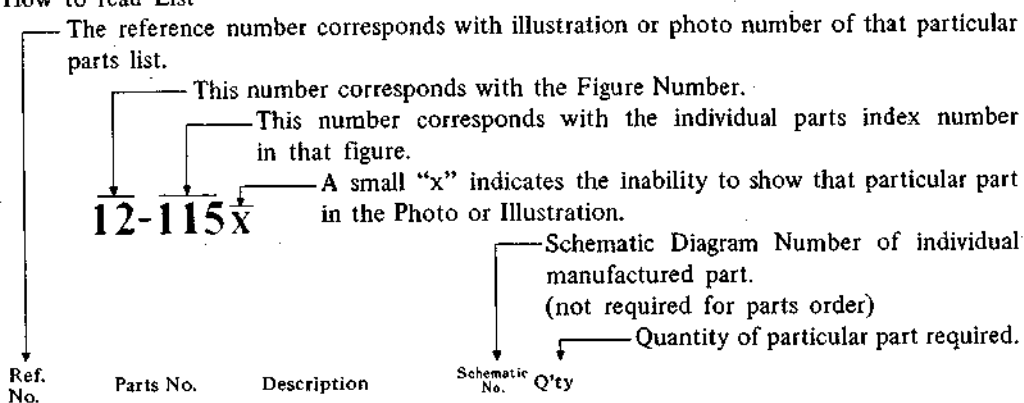

12-115x

FLYWHEEL BLOCK #13

12-115x	800425	Flywheel Block Assy. Comp.	RDG #13	1
12-116	244506	Flywheel Only	RD-233	1
12-117x	244754	Felt, Flywheel	RD-275	1
12-118	251324	Main Metal Case	RD-236	1
12-119	253080	Main Metal	RD-237	1

4. The symbol numbers shown on the P.C. Board list can be matched with the Composite Views of Components of the Schematic Diagram or Service Manual.
5. Please utilize separate "Common List for Service Parts" for Resistor Parts orders.
6. The shape of the parts and parts name, etc. can be confirmed by comparing them with the parts shown on the Electrical Parts Table of P.C. Board.
7. Both the kind of part and installation position can be determined by the Parts Number. To determine where a parts number is listed, utilize Parts Index at end of Parts List.
It is necessary first of all to find the Parts Number. This can be accomplished by using the Reference Number listed at right of parts number in the Parts Index. (meaning of ref. no. outlined in Item 3 above).
8. Utilize separate "Price List for Parts" to determine unit price. The most simple method of finding parts Price is to utilize the reference number.

CAUTION:

1. When placing an order for parts, be sure to list the parts no., model no., and description. There are instances in which if any of this information is omitted, parts cannot be shipped or the wrong parts will be delivered.
2. Please be careful not to make a mistake in the parts no. If the parts no. is in error, a part different from the one ordered may be delivered.
3. Because parts number and parts unit supply in the Preliminary Service Manual (Basic Parts List) may be partially changed, please use this parts list for all future reference.

NOTE: **△** INDICATES SAFETY CRITICAL COMPONENTS. FOR CONTINUED SAFETY, REPLACE SAFETY CRITICAL COMPONENTS ONLY WITH MANUFACTURER'S RECOMMENDED PARTS.

REMARQUE: **△** IL INDIQUE LES COMPOSANTS CRITIQUES DE SURETE. POUR MAINTENIR LE DEGRE DE SECURITE DE L'APPAREIL NE REMPLACER LES COMPOSANTS DONT LE FONCTIONNEMENT EST CRITIQUE POUR LA SECURITE QUE PAR DES PIECES RECOMMANDEES PAR LE FABRICANT.

AC INLET SYSTEM

This model is equipped with an AC INLET SYSTEM. Please refer to the AC INLET SYSTEM CHART below for the specific type. By the AC INLET SYSTEM, AC (mains) cord can be connected to and disconnected from the model because the model is provided with socket exclusively for AC (mains) cord on its main body. Please note, however, that certain models are not equipped with this system and has a built-in AC (mains) cord as before.

AC INLET SYSTEM CHART

CLASS I

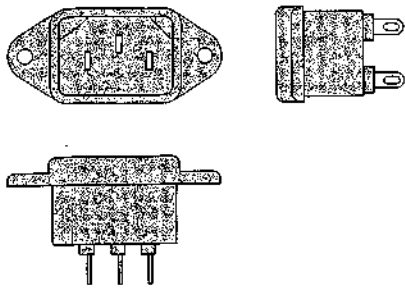

Picture 1
AC INLET
to be
installed
on machines

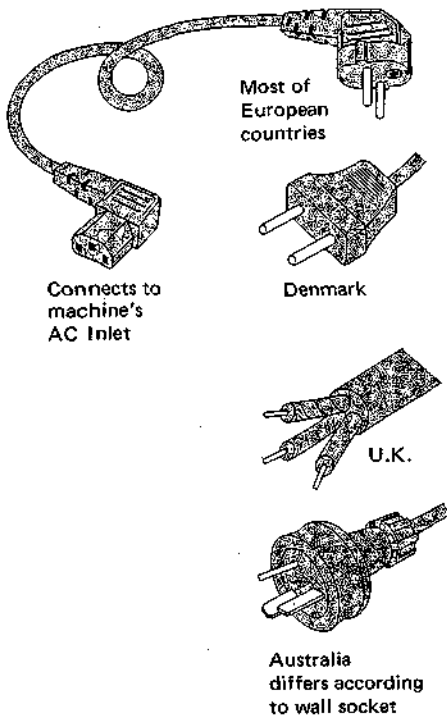

Picture 2
AC (mains)
cord

CLASS II

☐ This mark indicating double insulation will be attached to machine's rear panel

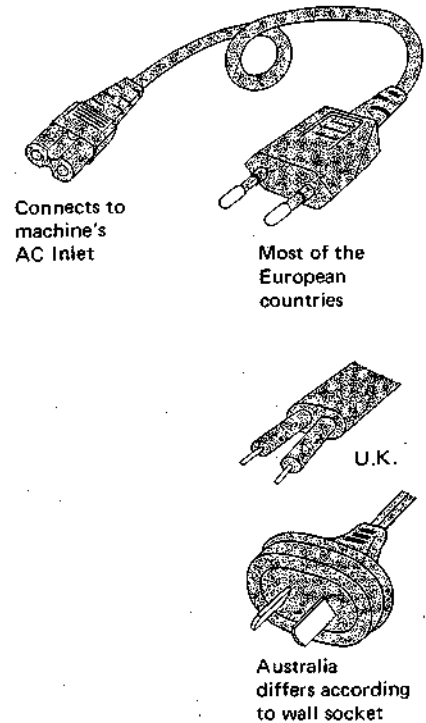
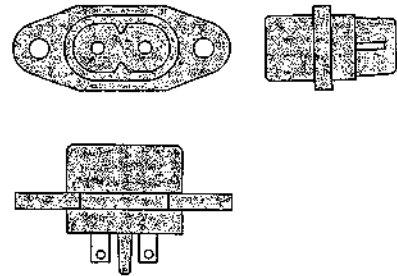

Parts List for AC (mains) Cord Set

	Standard	Description	Type of AC Inlet	Parts No.
Class I	CEE	Cord Set CEE (3 cores)	3P	EW302993
	BEAB	Cord Set BEAB (3 cores)	3P	EW302994
	SAA	Cord Set SAA (3 cores)	3P	EW302996
	U/T	Cord Set U/T (3 cores)	3P	EW302646
Class II	CEE	Cord Set CEE (2 cores)	2P	EW638144
	BEAB	Cord Set BEAB (2 cores)	2P	EW302995
	SAA	Cord Set SAA (2 cores)	2P	EW302991
	U/T	Cord Set U/T (2 cores)	2P	EW302899

1. RECOMMENDED SPARE PARTS LIST

Because, if the parts listed below are on hand, almost any repair can be accomplished, we suggest that you stock these Recommended Spare Parts Items.

Parts No.	Description	Notes
BA326004	Power Supply (A) P.C Board Comp. GX-M10 (U/T)	
BA326005	Power Supply (B) P.C Board Comp. GX-M10 (JPN)	
BA326007	Power Supply (B) P.C Board Comp. GX-M10 (AAL)	
BA326006	Power Supply (B) P.C Board Comp. GX-M10 (CSA)	
BA326008	Power Supply (C) P.C Board Comp. GX-M10 (CEE)	CEE, UK, SAA
BA326010	Pre Amp (New) P.C Board Comp. GX-M10 (JPN)	AAL, JPN
BA326016	Pre Amp (New) P.C Board Comp. GX-M10 (U/T)	U/T, CSA, CEE, UK, SAA
BA326002	Sys. Con (New) P.C Board Comp. GX-M10	
BL319692	Pinch Roller BLK GX-M10	
BM319691	Motor BLK GX-M10	
BR321540	Take-up Reel Table BLK	
BT321222	△ Power Trans. CET-21	U/T
BT321223	△ Power Trans. CET-22	JPN
BT321224	△ Power Trans. CET-23	CEE
BT321225	△ Power Trans. CET-24	AAL
BT321226	△ Power Trans. CET-25	CSA
BT321227	△ Power Trans. CET-26	UK, SAA
BZ321547	Take-up Idler BLK	
ED308952	Germanium Diode 1K34A-LR	
ED321269	LED GL5PR6	
ED315960	Silicon Diode WL02	
ED306109	Silicon Diode W03B	
ED560913	Silicon Diode 1S2473 VE	
ED310387	Zener Diode HZ12B-2	
ED313846	Zener Diode HZ16-3	
ED321347	7 Segment LED TLR-331	
EF310229	△ Fuse 1A 125V	CSA, AAL
EF309387	△ Fuse 1A 250V	U/T, JPN
EF315334	△ Fuse 250MA 125V	CSA, AAL
EF321323	△ Fuse 250MA 250V	U/T, JPN
EF309391	△ Fuse 800MA 125V	CSA, AAL
EF309388	△ Fuse 800MA 250V	U/T, JPN
EF300588	△ Fuse (EAWK)	CEE, UK, SAA
EF593706	△ Fuse (SEMKO T Type) 500MAT	CEE, UK, SAA
EF601942	△ Fuse (SEMKO T Type) 630MAT	CEE, UK, SAA
EI605013	IC NE545B	
EI315799	IC HA12019	
EI306141	IC LA4170	
EI321346	IC MSM5953RS	
EI213390	IC NJM4558D	
EI304657	IC TC4011BP	
EL321321	Lamp (Fuse Type) 3V 75MA	
EM321312	Bar Meter FIP48BW16YS	
EO321268	OSC Coil OSM-002	
EP321319	Plunger 0520PLTI	
ER309119	Dolby Filter D07-001	

Parts No.	Description	Notes
ER309120	Dolby Filter D07-003	
ES315159	△ Push SW. SDG1P (JPN)	JPN
ES310839	△ Push SW. SDG1P-E 5A/80A 250V	U/T
ES665875	△ Push SW. SDG1P-J TV-3 UL/CSA	AAL
ES655806	△ Push SW. SDG1P-J TV-3 CSA	CSA
ES665807	△ Push SW. SDG5P-E 5A/80A 250V	
ES301747	Leaf SW. BSW-1 TX-2	
ES317622	Leaf SW. BSW-47PB	
ES283173	Leaf SW. BUW-31PLC	
ES321310	Leaf SW. TX-3	
ES321274	Lever SW. 63349	
ES321212	Push SW. SUF-41	
ES316533	Push SW. SUF-12	
ES321266	Rotary Slide SW. SRZ-W04S	
ES283072	Slide SW. SSC22LP	U/T, CSA, CEE, UK, SAA
ES316535	Slide SW. 142031	
ET301464	FET 2SK68 (M) (N)	
ET539133	Transistor 2SA733 (P)	
ET554657	Transistor 2SA733 (P) (Q)	
ET603257	Transistor 2SC1312S (G) (H)	
ET308954	Transistor 2SC1844 (E) (F)	
ET310833	Transistor 2SC2274K (E)	
ET638504	Transistor 2SC945L (P)	
ET639437	Transistor 2SC945L (Q) (P)	
ET655356	Transistor 2SD571 (L) (M)	
ET307349	Transistor 2SD794 (P) (Q)	
EV321263	Double-Axial 2-Throw/Vol. V16L4DG8N 50kAx2	
EW306427	△ AC Cord (JPN)	
EW306428	△ AC Cord (U/T)	
EW313884	△ AC Cord BASEC	UK
EW305691	△ AC Cord CUL	CSA, AAL
EW313882	△ AC Cord EC	CEE
EW313883	△ AC Cord SAA	SAA
HE315742	Erase Head E-921	
HP319079	REC/PB Head PR4-7	
MB321391	AS Belt	
MB321389	Capstan Belt	
MB321392	Counter Belt	
MC321325	Counter SMP393-05	
MC321324	Counter SMP393-06	BL
MI319709	Flywheel Part GX-M10	
ML319693	AS Arm Assy	
MZ283140	△ Voltage Changer 12M-60031	U/T

2. HEAD BLOCK

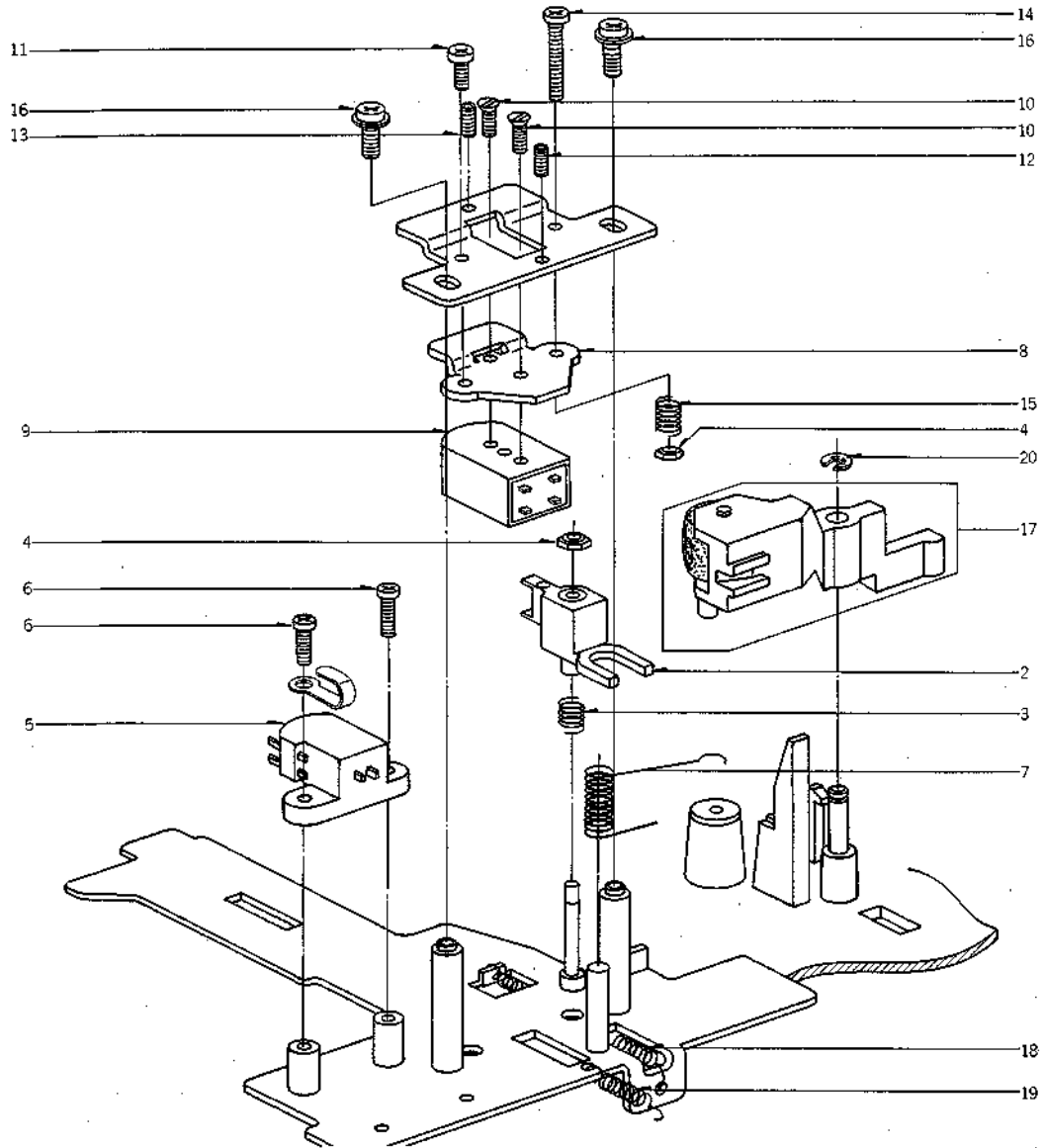

HEAD BLOCK

Ref. No.	Parts No.	Description	Schematic No.	Ref. No.	Parts No.	Description	Schematic No.
2-1	BH319689	Head BLK GX-M10		2-13	ZS521987	Set Screw, Hexagon Socket 2.6x4 (CUP/P.)	
2-2	HZ309128	Tape Guide	CF-0006	2-14	ZS462947	Screw, Pan 2.3x12	
2-3	ZG289236	Tape Guide Spring	CM-0005	2-15	ZG465636	Angle Adjust Spring	CG-0029
2-4	ZW313501	Nut #2 M2.3		2-16	ZS283454	Screw, Pan 2.6x6 W=5	
2-5	HE315742	Erase Head E-921	37-2-25	2-17	BL319692	Pinch Roller BLK GX-M10	CE-1202
2-6	ZS419940	Screw, Pan 2.3x6		2-18	ZG312945	Coil Spring T1-3.2/0.29-14.0	CE-1083
2-7	ZG321536	Pinch Spring (B)	CE-0010	2-19	ZG321535	PB Spring	6-1-9
2-8	HZ316252	Head Angle	CM-0304	2-20	ZW357164	'E' Ring 2.3M	
2-9	HP319079	REC/PB Head PR4-7					
2-10	ZS524812	Screw, countersunk 2x4					
2-11	ZS590804	Screw, pan 2.3x6					
2-12	ZS499454	Set Screw, Hexagon Socket 2.6x3 (CUP/P.)					

When ordering parts, please describe Parts Number, Description, and Model Number in detail.

3. MECHA ASSEMBLY BLOCK (1)

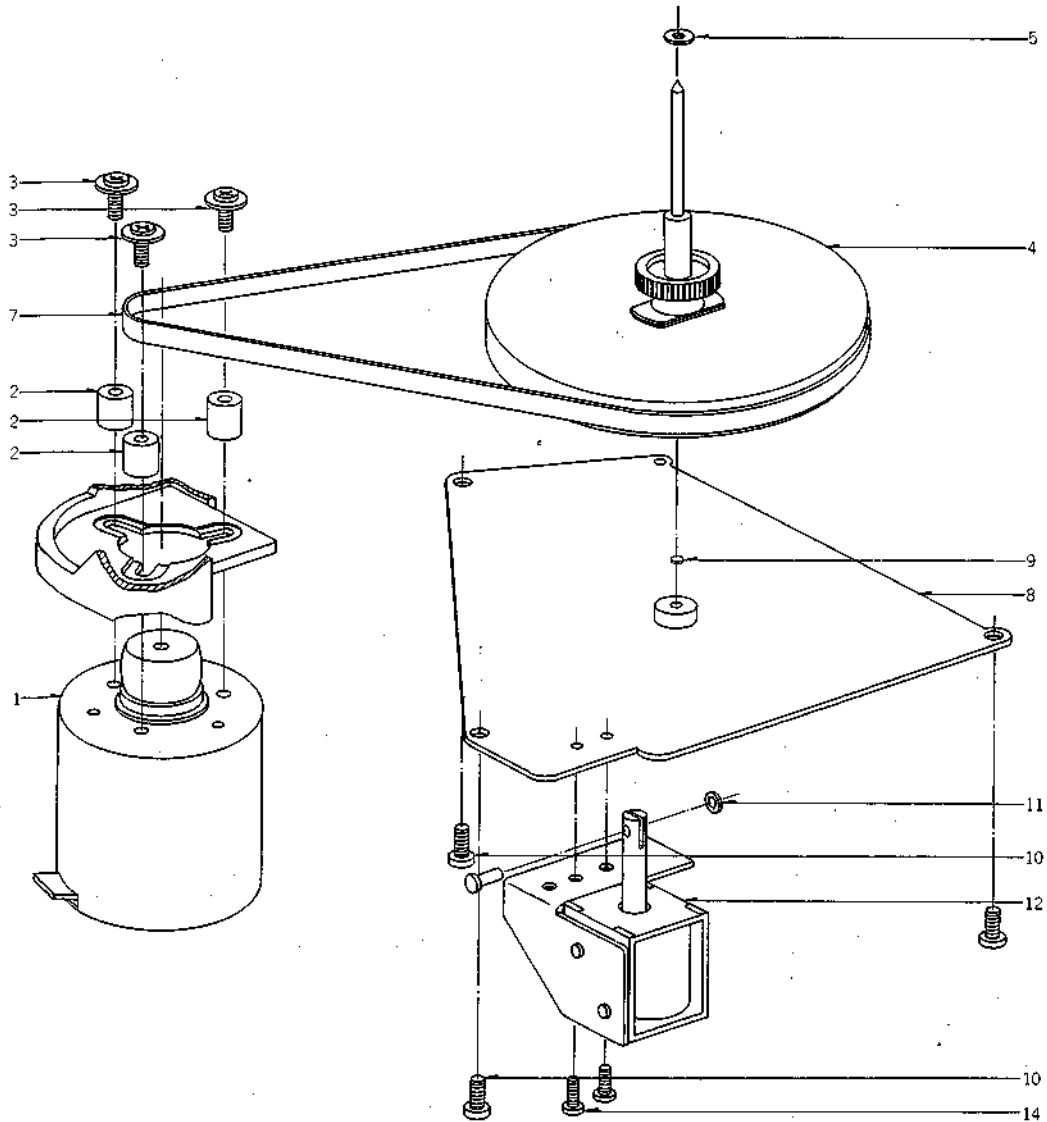

MECHA ASSEMBLY BLOCK (1)

Ref. No.	Parts No.	Description	Schematic No.	Ref. No.	Parts No.	Description	Schematic No.
MOTOR BLOCK							
3-1	BM319691	Motor BLK GX-M10	CE-7201	3-7	MB321389	Capstan Belt	CE-1027
MECHA ASSEMBLY BLOCK							
3-2	MB282778	Rubber Bush	CN-7003	3-8	MI319686	Flywheel Hold Plate (B) Part GX-M10	CE-1061
3-3	ZS321338	Motor Screw	7-1-75	3-9	ZW321424	Thrust Washer	CE-1063
3-4	MI319709	Flywheel Part GX-M10	CE-1025	3-10	ZS322402	Special Tapping Screw, Pan 3x8	7-1-70
3-5	ZW269335	Washer (Nylon) D2.3x6x0.3t		3-11	ZW321437	Push Washer	CE-1077
3-6x	MB321391	AS Belt	CE-1028	3-12	EP321319	Plunger 0520PLTI	44-1-118
				3-13x	ZS477876	Screw, Pan 2x3	
				3-14	ZS432843	Screw, Pan 2.6x4	

When ordering parts, please describe Parts Number, Description, and Model Number in detail.

4. MECHA ASSEMBLY BLOCK (2)

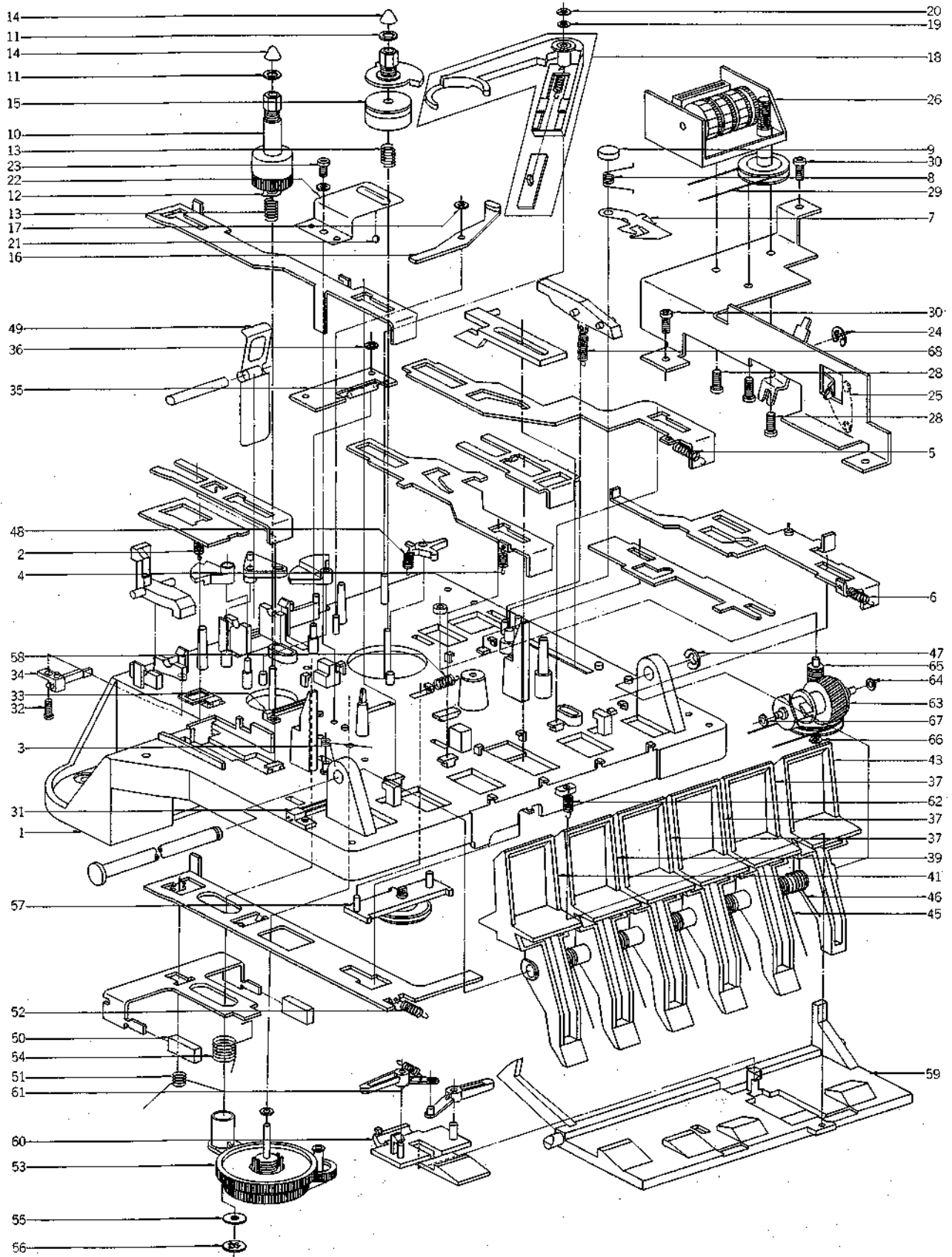

MECHA ASSEMBLY BLOCK (2)

Ref. No.	Parts No.	Description	Schematic No.
4-1	TC319723	Chassis Part GX-M10	CE-1001
4-2	ZG312926	Coil Spring T1-3.2/0.2-16.0	
4-3	ZG321373	Stop Spring	CE-1007
4-4	ZG312943	Coil Spring T1-3.2/0.29-11.2	
4-5	ZG324329	Coil Spring T2-3.2/0.29-11.2	
4-6	ZG324330	Pause Spring	CE-1085
4-7	MZ321396	Lock Cam	CE-1034
4-8	ZG314440	Button Lock Sprin (B)	CG-2303
4-9	TC282396	Cap	CN-1055
4-10	BR321539	Supply Reel Table BLK	9-3-60
4-11	ZW381644	Washer (Polyslider) D2.1x4x0.13t	
4-12	ZW321393	BT Washer (Polyslider)	CE-1030
4-13	ZG321538	BT Spring	CE-1081
4-14	MT305793	Reel Cap	CF-2039
4-15	BR321540	Take-up Reel Table BLK	9-3-61
4-16	ML321404	Release Lever	CE-1043
4-17	ZW340648	Clip (CS Type) CSTW-2	6-1-14
4-18	ML319693	AS Arm Assy	CE-1203
4-19	ZW305546	Washer (Polyslider) D2.1x4x0.25t	
4-20	ZW321437	Push Washer	CE-1077
4-21	MV368886	Steel Ball D3	
4-22	ZG321384	Hold Spring	CE-1021
4-23	ZS310343	Special Tapping Screw, Pan 3x6	7-1-70
4-24	ZW270101	'E' Ring 3M	6-1-9
4-25	ZG321411	Timer Spring	CE-1050
4-26	MC321325	Counter SMP393-05	9-1-75
4-27x	MC321324	Counter SMP393-06	9-1-76
4-28	ZS417216	Screw, Pan 3x4 (BL)	
4-29	MB321392	Counter Belt	CE-1029
4-30	ZS322402	Special Tapping Screw, Pan 3x8	7-1-70
4-31	ES283173	Leaf SW. BUW-31PLC	25-10-26
4-32	ZS321320	B-Tight Screw, Pan 2x6	
4-33	ES321310	Leaf SW. TX-3	25-10-39
4-34	ES317622	Leaf SW. BSW-47PB	25-10-40
4-35	EL321321	Lamp (Fuse Type) 3V 75MA	28-2-76
4-36	ZW340648	Clip (CS Type) CSTW-2	6-1-14
4-37	TC321362	Key Board (A)	CE-1002
4-38x	TC321363	Key Board (A-BL)	CE-1002
4-39	TC321364	Key Board (D)	CE-1002
4-40x	TC321365	Key Board (D-BL)	CE-1002
4-41	TC321367	Key Board (B)	CE-1003
4-42x	TC321368	Key Board (B-BL)	CE-1003
4-43	TC321369	Key Board (C)	CE-1004
4-44x	TC321370	Key Board (C-BL)	CE-1004
4-45	ZG321430	Key Board Spring (A)	CE-1069
4-46	ZG321431	Key Board Spring (B)	CE-1070
4-47	ZW270123	'E' Ring 4M	6-1-9
4-48	ZG321544	Relay Lever Spring	CE-1082
4-49	MZ321417	Cassette Holder	CE-1055
4-50	TC321415	Brake Shoe	CE-1053
4-51	ZG321416	Brake Spring	CE-1054
4-52	ZG318228	Coil Spring T2-3.2/0.29-14	
4-53	BZ321546	Middle Gear BLK	9-3-62
4-54	ZG325100	Gear Return Spring	CE-1087
4-55	ZW460787	Washer (Polyslider) D3.1x8x0.25t	
4-56	ZW653163	Retaining Ring CS CSTW-3	6-1-14
4-57	BZ321547	Take-up Idler BLK	9-3-63
4-58	ZG312920	Coil Spring T1-3.2/0.2-8.0	
4-59	MZ321418	Key Board Cam	CE-1056
4-60	MZ321419	PB Cam	CE-1057
4-61	ZG321549	Coil Spring T2-3.2/0.2-10.0	
4-62	ZG321548	Key Board Cam Spring	CE-1084
4-63	TC319724	Worm Gear Part GX-M10	CE-1039
4-64	ZW321317	Washer (Polyslider) D2.1x4x0.5t	
4-65	MR321403	Warm Pulley	CE-1042
4-66	ZW321437	Push Washer	CE-1077
4-67	ZW305546	Washer (Polyslider) D2.1x4x0.25t	
4-68	ZG321303	Coil Spring T2-3.2/0.2-18.0	
4-69x	ZS322402	Special Tapping Screw, Pan 3x8	7-1-70

5. PRE AMP (NEW) P.C BOARD (CE-5201A) BLOCK

Symbol No.	Parts No.	Description	Schematic No.	Symbol No.	Parts No.	Description	Schematic No.
5-1	BA32601 6	Pre Amp (New) P.C Board Comp GX-M10(U/T) (U/T, CA, CE, UK, SAA)	CE-5201A	5-C45	EC321341	Polypropylene Film/C. (Vert.) 0.0075 μ F(G)	24-22-6
5-2	BA32601 O	Pre Amp (New) P.C Board Comp GX-M10 (JPN) (JPN, AAL)	CE-5201A	5-C46	EC321342	Polypropylene Film/C. (Vert.) 0.0068 μ F(G)	24-22-6
5-IC1	EI605013	IC NE545B	45-8-117	5-C49	EC321349	Polypropylene/C. 0.0022 μ F(J) 630WV	24-22-9
5-IC2	EI306141	IC LA4170	45-8-305	5-C56	EC321292	Solid Aluminum/C. 0.15 μ F(K) 25WV	24-23-8
5-TR1	ET308954	Transistor 2SC1844(E)(F)	45-1-327	5-C63	EC321061	Solid Aluminum/C. 0.1 μ F(K) 25WV	24-23-8
5-TR2	ET603257	Transistor 2SC1312S(G)(H)	45-1-182	5-C74	EC306980	Styrol/C. 220PF(J) 50WV	24-11-14
5-TR3to5	ET639437	Transistor 2SC945L(Q)(P)	45-1-85	5-3	EJ326017	Pin Jack Assy 4P GX-M10 (U/T)	CE-5210
5-TR6	ET301464	FET 2SK68(M)(N)	45-12-14	5-4	EJ326009	Pin Jack Assy 4P GX-M10 (JPN)	CE-5210
5-TR7	ET638504	Transistor 2SC945L(P)	45-1-85	5-5	ZW263946	Nylon Rivet 4x5	2-7-57
5-TR8,9	ET539133	Transistor 2SA733(P)	45-1-124	5-6	ZS325495	Tapping Screw, #2 BR 3x6	
5-TR10,11	ET310833	Transistor 2SC2274K(E)	45-1-335	5-7	ZW273802	Toothed Lock Washer, M3	
5-TR12	ET655356	Transistor 2SD571(L)(M)	45-1-218				
5-TR13	ET639437	Transistor 2SC945L(Q)(P)	45-1-85				
5-TR14	ET554657	Transistor 2SA733(P)(Q)	45-1-124				
5-D1	ED308952	Germanium Diode 1K34A-LR	45-3-47				
5-D2to5	ED560913	Silicon Diode 1S2473 VE	45-3-23				
5-D6,7	ED308952	Germanium Diode 1K34A-LR	45-3-47				
5-D8,9	ED560913	Silicon Diode 1S2473 VE	45-3-23				
5-D10	ED308952	Germanium Diode 1K34A-LR	45-3-47				
5-D11	ED560913	Silicon Diode 1S2473 VE	45-3-23				
5-J1	EJ321328	Jack HLJ0345-01-010	31-2-110				
5-J3	EJ316156	Head Phone Jack HLJ0315-01-020	31-2-106				
5-SW1	ES316535	Slide SW. 142031	25-3-177				
5-SW2	ES283072	Slide SW. SSC22LP	25-3-131				
5-SW3	ES321274	Lever SW. 63349	25-12-65				
5-SW4	ES321266	Rotary Slide SW. SRZ-W04S	25-6-183				
5-SW5	ES316533	Push SW. SUF12	25-5-335				
5-VR1	EV321264	Single-Axial 2-Throw/Vol. V16L4G3N 10kAx2	36-22-50				
5-VR3	EV315412	Semi-Fixed/Vol. D8 Axial 5k Ω	36-10-280				
5-VR4	EV315413	Semi-Fixed/Vol. D8 Axial 50k Ω	36-10-280				
5-VR5,6	EV322416	Semi-Fixed/Vol. D8 Axial 30k Ω	36-10-280				
5-VR7,8	EV315413	Semi-Fixed/Vol. D8 Axial 50k Ω	36-10-280				
5-VR9	EV315414	Semi-Fixed/Vol. D8 Axial 20k Ω	36-10-280				
5-VR10	EV314968	Semi-Fixed/Vol. D10 Axial 100k Ω	36-10-281				
5-VL1	EO321336	Vari. Inductor FE-002 10MH	23-1-333				
5-L1	EO321295	Ferri Inductor 4.7 μ H(J)	23-1-335				
5-T1	EO321268	OSC Coil OSM-002	23-4-55				
5-FL1	ER309120	Dolby Filter D07-003	53-1-143				
5-FL2	ER309119	Dolby Filter D07-001	53-1-143				
5-FL3,4	EO315758	Trap Coil 100S-431	23-1-331				
5-FR1	ER319510	Fuse/R. 1/4W 56 ohms(J)	35-14-23				
5-R96	ER321290	Metal Oxide Film/R. 2W 120 ohms(J)	35-11-22				
5-C4	EC306419	Styrol/C. 680PF(J) 50WV	24-11-14				
5-C8	EC306988	Styrol/C. 330PF(J) 50WV	24-11-14				
5-C25	EC321061	Solid Aluminum/C. 0.1 μ F(K) 25WV	24-23-8				
5-C32	EC321292	Solid Aluminum/C. 0.15 μ F(K) 25WV	24-23-8				
5-C43	EC321339	Polypropylene Film/C. (Vert.) 0.0091 μ F(G)	24-22-6				
5-C44	EC321340	Polypropylene Film/C. (Vert.) 0.0082 μ F(G)	24-22-6				

When ordering parts, please describe Parts Number, Description, and Model Number in detail.

6. SYS. CON (NEW) P.C BOARD (CE-5206A) BLOCK

Symbol No.	Parts No.	Description	Schematic No.
6-1	BA326002	Sys. Con (New) P.C Board Comp. GX-M10	CE-5217
6-IC1	EI213390	IC NJM4558D	45-8-191
6-IC2	EI321346	IC MSM5953RS	45-8-380
6-IC3	EI304657	IC TC4011BP	45-8-232
6-TR1	ET639437	Transistor 2SC945L(Q)(P)	45-1-85
6-TR2	ET554657	Transistor 2SA733(P)(Q)	45-1-124
6-TR3to5	ET639437	Transistor 2SC945L(Q)(P)	45-1-85
6-TR6	ET307349	Transistor 2SD794(P)(Q)	45-1-334
6-D1to10	ED560913	Silicon Diode 1S2473 VE	45-3-23
6-D11	ED306109	Silicon Diode W03B	45-2-78
6-D12	ED310387	Zener Diode HZ12B-2	45-6-80
6-D13,14	ED560913	Silicon Diode 1S2473 VE	45-3-23
6-D15,16	ED308952	Germanium Diode 1K34A-LR	45-3-47
6-SW1to4	ES321212	Push SW. SUP-41	25-5-343
6-C1	EC316569	Solid Aluminum/C. 0.22 μ F(K) 25WV	24-19-3
6-C5	EC313532	NP/C. 1 μ F(M) 50WV	24-17-31
6-C8	EC313826	Solid Aluminum/C. 0.1 μ F(K) 25WV	24-19-3
6-C9	EC321343	NP/C. 0.1 μ F(M) 50WV	24-17-31
6-C12to14	EC313532	NP/C. 1 μ F(M) 50WV	24-17-31
6-2	ZS422076	Screw, Pan 3x5	

7. POWER SUPPLY (A/B) P.C BOARD (CE-5202/5205) BLOCK

Symbol No.	Parts No.	Description	Schematic No.
7-1	BA326004	Power Supply (A) P.C Board Comp GX-M10 (U/T)	CE-5220
7-2	BA326005	Power Supply (B) P.C Board Comp GX-M10 (JPN)	CE-5220
7-3	BA326006	Power Supply (B) P.C Board Comp GX-M10 (CSA)	CE-5220
7-4	BA326007	Power Supply (B) P.C Board Comp GX-M10 (AAL)	CE-5220
7-5	BA326008	Power Supply (C) P.C Board Comp GX-M10 (CEE) (CEE, UK, SAA)	CE-5220
7-TR1	ET307349	Transistor 2SD794(P)(Q)	45-1-334
7-D1	ED315960	Silicon Diode WL02	45-2-98
7-D2	ED313846	Zener Diode HZ16-3	45-6-80
7-SW1	ES310839	Δ Push SW. SDG1P-E 5A/80A 250V	25-5-310
7-SW1	ES315159	Δ Push SW. SDG1P (JPN)	25-5-330
7-SW1	ES655806	Δ Push SW. SDG1P-J TV3 (CSA)	25-5-187
7-SW1	ES665875	Δ Push SW. SDG1P-J TV-3 (UL/CSA) (AAL)	25-5-199
7-SW1	ES665807	Δ Push SW. SDG5P-E 5A/80A 250V (CEE,UK,SAA)	25-5-182
7-VS1	MZ283140	Δ Voltage Changer 12M-60031 (U/T)	40-2-13
7-R1	ER321228	Carbon/R. F L/2W 470 ohms(J)	35-11-27
7-R3	ER305722	Metal Oxide Film/R. 2W 220 ohms(J)	35-11-22
7-R4	ER321290	Metal Oxide Film/R. 2W 120 ohms(J)	35-11-22
7-C3	EC316230	Elect./C. (Vert.) 2200 μ F 35WV	24-12-46
7-C7	EC316230	Elect./C. (Vert.) 2200 μ F 35WV	24-12-46
7-C9	EC321302	Ceramic/C. E 0.01 μ F(Z) 250VAC (U/T, JPN, AAL)	24-5-90
7-C9	EC314688	Ceramic/C. DE7150 FZ 0.01 μ F(P) 125WV (CSA)	24-5-87
7-C9	EC301320	MP/C. 4700PF(M) 250WV (CEE, UK, SAA)	24-9-122
7-6	ZS379350	Screw, Pan 3x6	
7-7	ZS325495	Tapping Screw, #2 BR 3x6	

8. BAR METER P.C BOARD (CE-5209) BLOCK

Symbol No.	Parts No.	Description	Schematic No.
8-IC1,2	EI315799	IC HA12019	45-8-366
8-IND1	EM321312	Bar Meter FIP48BW16YS	59-1-1

9. ASSEMBLY BLOCK

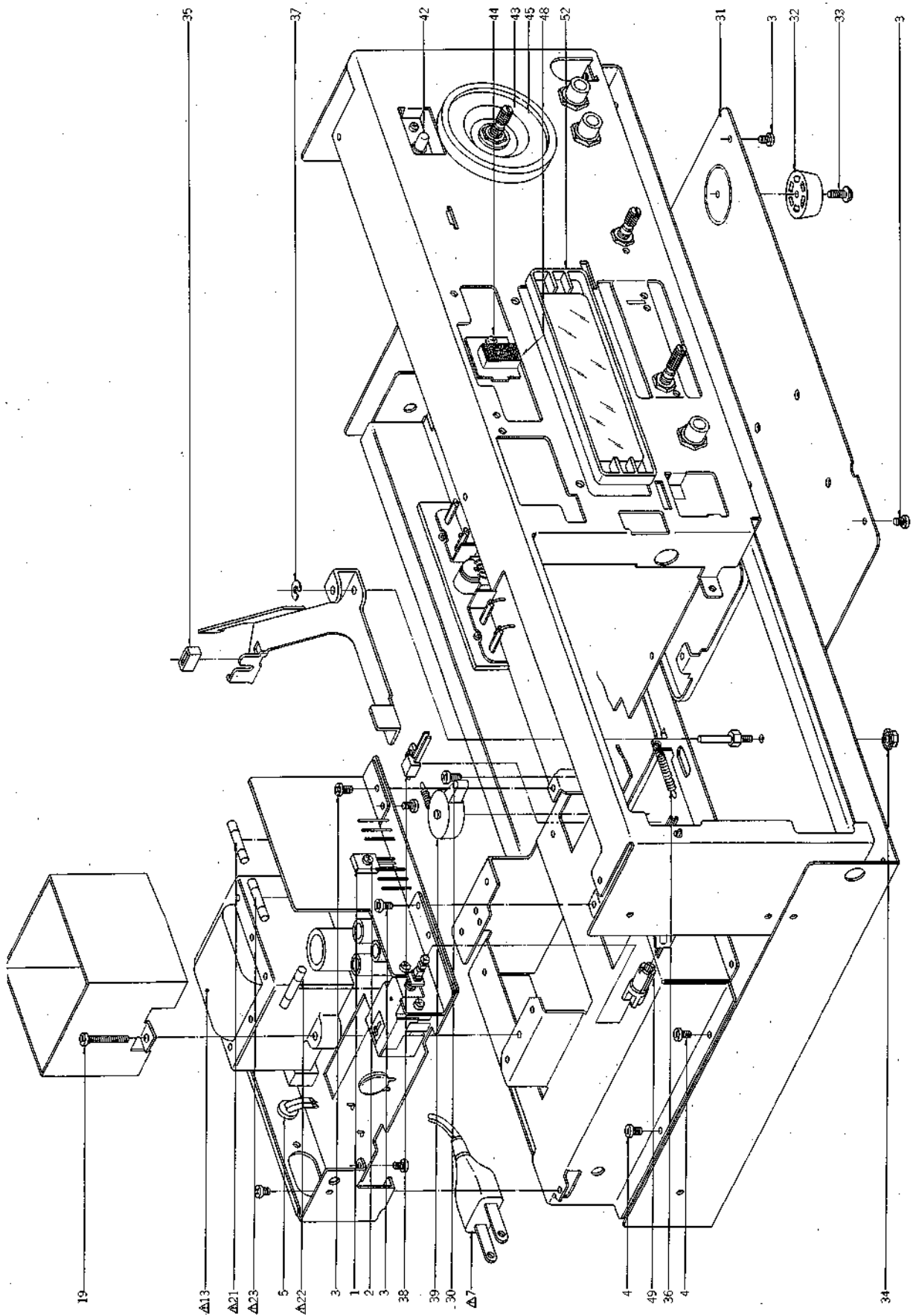

ASSEMBLY BLOCK

Ref. No.	Parts No.	Description	Schematic No.
POWER SUPPLY BLOCK			
9-1	ET307349	Transistor 2SD794(P)(Q)	45-1-334
9-2	ZS379350	Screw, Pan 3x6	
9-3	ZS325495	Tapping Screw, #2 BR 3x6	
9-4	ZS447840	Tapping Screw, #2 BR 3x8	
9-5	EZ631945	Strain Relief SR-4N-4	
		(U/T, JPN, CSA, AAL)	2-7-49
9-6x	EJ692908	Strain Relief SR-5N-4	
		(CEE, UK, SAA)	2-7-60
9-7	EW306428	Δ AC Cord (U/T)	26-3-64
9-8x	EW306427	Δ AC Cord (JPN)	26-3-63
9-9x	EW305691	Δ AC Cord CUL (CSA, AAL)	26-3-65
9-10x	EW313882	Δ AC Cord EC (CEE)	26-3-66
9-11x	EW313884	Δ AC Cord BASEC (UK)	26-3-67
9-12x	EW313883	Δ AC Cord SAA (SAA)	26-3-69
9-13	BT321222	Δ Power Trans. CET-21 (U/T)	38-4-745
9-14x	BT321223	Δ Power Trans. CET-22 (JPN)	38-4-746
9-15x	BT321226	Δ Power Trans. CET-25 (CSA)	38-4-749
9-16x	BT321225	Δ Power Trans. CET-24 (AAL)	38-4-748
9-17x	BT321224	Δ Power Trans. CET-23 (CEE)	38-4-747
9-18x	BT321227	Δ Power Trans. CET-26	
		(UK, SAA)	38-4-750
9-19	ZS321279	Tapping Screw, #2 BR 3x18	
		(U/T, JPN, CSA, AAL)	
9-20x	ZS308513	Tapping Screw, #2 BR 3x12	
		W=3 (CEE, UK, SAA)	
9-21	EF321323	Δ Fuse 250MA 250V (U/T, JPN)	39-1-64
9-22	EF309388	Δ Fuse 800MA 250V (U/T, JPN)	39-1-64
9-23	EF309387	Δ Fuse 1A 250V (U/T, JPN)	39-1-64
9-24x	EF315334	Δ Fuse 250MA 125V	
		(CSA, AAL)	39-1-65
9-25x	EF309391	Δ Fuse 800MA 125V	
		(CSA, AAL)	39-1-65
9-26x	EF310229	Δ Fuse 1A 125V (CSA, AAL)	39-1-65
9-27x	EF300588	Δ Fuse (EAWK) (CEE, UK, SAA)	39-1-60
9-28x	EF593706	Δ Fuse (SEMKO T Type)	
		500MAT (CEE, UK, SAA)	39-1-53
9-29x	EF601942	Δ Fuse (SEMKO T Type)	
		630MAT (CEE, UK, SAA)	39-1-53
AMP CHASSIS BLOCK			
9-30	ZS306021	S-Tight Screw, Pan 3x6	
9-31	SP321464	Bottom Plate	CE-5013
9-32	SA306240	Rubber Foot (B)	LE-6740
9-33	ZS306463	S-Tight Screw, Pan 3x8 w/Flange	
9-34	ZW413267	Flange Nut M4	
9-35	MB510164	Cushion Rubber	CG-7306
9-36	ZG305641	REC Spring	CN-5313
9-37	ZW290283	'U' Ring 2.85M	6-1-1
9-38	ES301747	Leaf SW. BSW-1F TX-2	25-10-30
9-39	TC305728	Oil Clutch Comp. (E) GXC-706D	CN-5335
ASSEMBLY BLOCK			
9-40x	ZS200676	Tapping Screw, #2	
		Countersunk 3x6	
9-41x	ZS321537	Special Tapping Screw, 3x10	7-1-70
9-42	ED321269	LED GL5PR6	45-15-34
9-43	EV321263	Double-Axial 2-Throw/Vol.	
		VI6L4DG8N 50kA x2	36-18-20
9-44x	ZS422076	Screw, Pan 3x5	
9-45	SE319671	Knob Escatcheon Part GX-M10	CE-6220
9-46x	SE319672	Knob Escatcheon (BL) Part	
		GX-M10-BL	CE-6220
9-47x	ZW260370	Nylon Rivet 3.4x5.5	2-7-56
9-48	ED321347	7 Segment LED TLR-331	45-15-33
9-49	ML321550	Joint	CE-6205
9-50x	ML321472	Joint	CE-5021
9-51x	ML321376	Safety Lever (A)	CE-1011
9-52	ML321466	Meter Holder	CE-5015

10. FINAL ASSEMBLY BLOCK

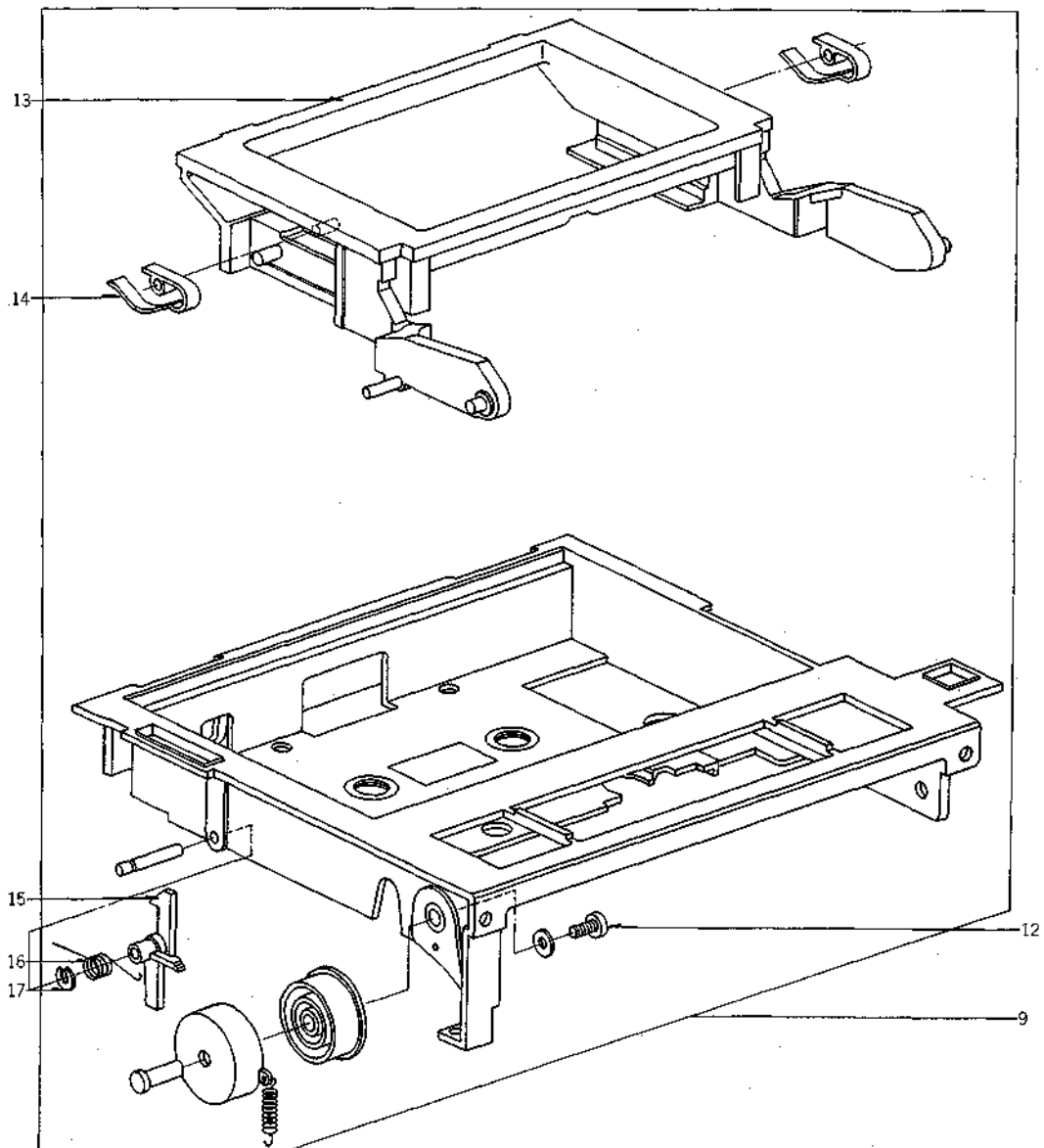
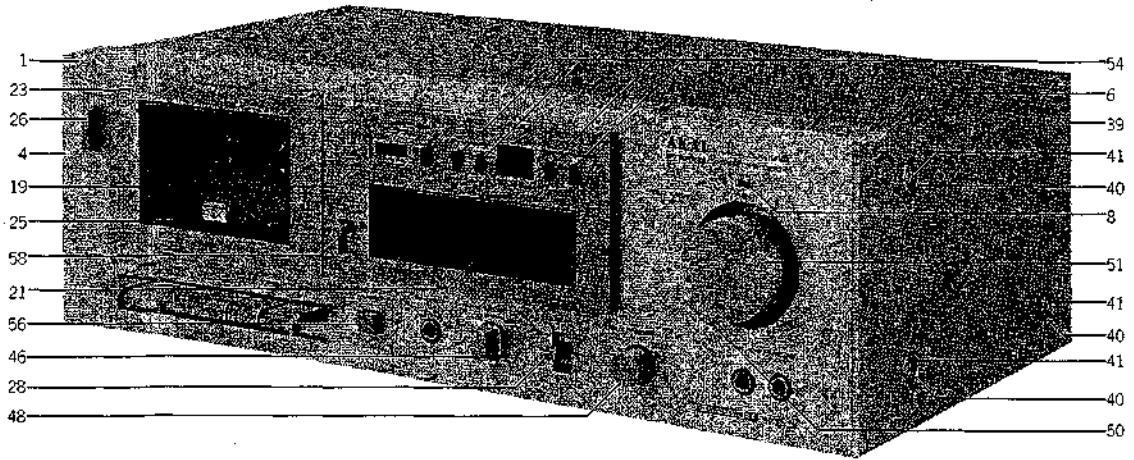

FINAL ASSEMBLY BLOCK

Ref. No.	Parts No.	Description	Schematic No.
FRONT PANEL BLOCK			
10-1	BD319673	Front Panel BLK GX-M10 (U/T) (Except JPN, AAL)	CE-6216
10-2x	BD319738	Front Panel BLK GX-M10 (JPN) (JPN, AAL)	CE-6216
10-3x	BD319674	Front Panel BLK GX-M10-BL	CE-6216
10-4	TC321479	Side Mold (L)	CE-6004
10-5x	TC321478	Side Mold (L-BL)	CE-6004
10-6	TC321481	Side Mold (R)	CE-6004
10-7x	TC321480	Side Mold (R-BL)	CE-6004
10-8	TC321483	REC Indicator	CE-6006
10-9	BZ324600	LID Housing Assy GX-M10	CE-6217
10-10x	BZ324597	Lid Housing Assy GX-M10-BL	CE-6217
10-11x	ZW550697	Washer (SPC) D2.9x7.4x0.5t	
10-12	ZS608220	Screw, Pan 2.6x6	
10-13	TC321486	LID Frame	CE-6010
10-14	ZG321487	Mold Spring	CE-6011
10-15	TC321488	Lock Plate	CE-6013
10-16	ZG321490	Lock Spring	CE-6015
10-17	ZW270088	'E' Ring 1.9M	6-1-9
10-18x	ZW260370	Nylon Rivet 3.4x5.5	2-7-56
10-19	SZ319675	Meter Window Assy	CE-6218
10-20x	SZ319676	Meter Window Assy (BL)	CE-6218
10-21	SZ321494	Meter Window	CE-6018
10-22x	ZW305006	Nylon Rivet 4x5	2-7-53
10-23	BD319677	Lid Panel Assy GX-M10	CE-6219
10-24x	BD319678	Lid Panel Assy GX-M10-BL	CE-6219
10-25	SM315737	Super GX Name Plate	CF-6236
FINAL ASSEMBLY BLOCK			
10-26	SB316498	Button (B)	CU-6009
10-27x	SB316499	Button (B-BL)	CU-6009
10-28	SK321500	Lever Knob (A)	CE-6025
10-29x	SK321501	Lever Knob (A-BL)	CE-6025
10-30x	ZS325495	Tapping Screw, #2 BR 3x6	
10-31x	ZS406416	Tapping Screw, #2 Countersunk 3x8	
10-32x	SP319449	Back Board (A-6) (U/T)	CE-6040,6206
10-33x	SP319450	Back Board (B-6) (JPN)	CE-6036,6206
10-34x	SP319451	Back Board (C-6) (CSA)	CE-6040,6206
10-35x	SP324592	Back Board (F-6) (AAL)	CE-6036,6037
10-36x	SP319452	Back Board (D-6) (CEE)	CE-6040,6207
10-37x	SP319453	Back Board (E-6) (UK,SAA)	CE-6040,6207
10-38x	ZS225134	Tapping Screw, #2 Pan 3x10, w/Washer	
10-39	BC321509	Upper Cover (A) (Except AAL, BL)	CE-6030
10-40	ZW315929	Spot Facing Washer (B)	MU-6028
10-41	ZS315878	S-Tight Screw, Bind 4x8	
10-42x	BC321508	Upper Cover (B) (AAL)	CE-6029
10-43x	BC321510	Upper Cover (A-BL)	CE-6030
10-44x	ZS310588	S-Tight Screw, Bind 4x8 (Black)	
10-45x	ZW548010	Spot Facing Washer (Black)	MU-6028
10-46	SK321502	Knob (A)	CE-6026
10-47x	SK321503	Knob (A-BL)	CE-6026
10-48	SK315932	Knob (C)	CM-6308
10-49x	SK315933	Knob (C-BL)	CM-6308
10-50	SK321506	Double Knob (Lower)	CE-6028
10-51	SK321504	Double Knob (Upper)	CE-6027
10-52	SK321507	Double Knob (Lower-BL)	CE-6028
10-53x	SK321505	Double Knob (Upper-BL)	CE-6027
10-54	SB321522	Button (A)	CE-6202
10-55x	SB321523	Button (A-BL)	CE-6202
10-56	SB316316	Button (B)	CM-6305
10-57x	SB316317	Button (B-BL)	CM-6305

INDEX

Parts No.	Ref. No. & Symbol No.	Parts No.	Ref. No. & Symbol No.	Parts No.	Ref. No. & Symbol No.	Parts No.	Ref. No. & Symbol No.	Parts No.	Ref. No. & Symbol No.
BA326002	6-1	EI315799	8-IC1,2	MI319709	3-4	ZG321490	10-16		
BA326004	7-1	EI321346	6-IC2	ML319693	4-18	ZG321535	2-19		
BA326005	7-2	EI605013	5-IC1	ML321376	9-51x	ZG321536	2-7		
BA326006	7-3	EJ316156	5-J3	ML321404	4-16	ZG321538	4-13		
BA326007	7-4	EJ321328	5-J1	ML321466	9-52	ZG321544	4-48		
BA326008	7-5	EJ326009	5-4	ML321472	9-50x	ZG321548	4-62		
BA326010	5-2	EJ326017	5-3	ML321550	9-49	ZG321549	4-61		
BA326016	5-1	EJ692908	9-6x	MR321403	4-65	ZG324329	4-5		
BC321508	10-42x	EL321321	4-35	MT305793	4-14	ZG324330	4-6		
BC321509	10-39	EM321312	8-IND1	MV368886	4-21	ZG325100	4-54		
BC321510	10-43x	EO315758	5-FL3,4	MZ283140	7-VS1	ZG465636	2-15		
BD319673	10-1	EO321268	5-T1	MZ321396	4-7	ZG514440	4-8		
BD319674	10-3x	EO321295	5-L1	MZ321417	4-49	ZS200676	9-40x		
BD319677	10-23	EO321336	5-VL1	MZ321418	4-59	ZS225134	10-38x		
BD319678	10-24x	EP321319	3-12	MZ321419	4-60	ZS283454	2-16		
BD319738	10-2x	ER305722	7-R3	SA306240	9-32	ZS306021	9-30		
BH319689	2-1x	ER309119	5-FL2	SB316316	10-56	ZS306463	9-33		
BL319692	2-17	ER309120	5-FL1	SB316317	10-57x	ZS308513	9-20x		
BM319691	3-1	ER319510	5-FR1	SB316498	10-26	ZS310343	4-23		
BR321539	4-10	ER321228	7-R1	SB316499	10-27x	ZS310588	10-44x		
BR321540	4-15	ER321290	5-R96	SB321522	10-54	ZS315878	10-41		
BT321222	9-13	ER321290	7-R4	SB321523	10-55x	ZS321279	9-19		
BT321223	9-14x	ES283072	5-SW2	SE319671	9-45	ZS321320	4-32		
BT321224	9-17x	ES283173	4-31	SE319672	9-46x	ZS321338	3-3		
BT321225	9-16x	ES301747	9-38	SK315932	10-48	ZS321537	9-41x		
BT321226	9-15x	ES310839	7-SW1	SK315933	10-49x	ZS322402	3-10		
BT321227	9-18x	ES315159	7-SW1	SK321500	10-28	ZS322402	4-30		
BZ321546	4-53	ES316533	5-SW5	SK321501	10-29x	ZS322402	4-69x		
BZ321547	4-57	ES316535	5-SW1	SK321502	10-46	ZS325495	5-6		
BZ324597	10-10x	ES317622	4-34	SK321503	10-47x	ZS325495	7-7		
BZ324600	10-9	ES321212	6-SW1to4	SK321504	10-51	ZS325495	9-3		
EC301320	7-C9	ES321266	5-SW4	SK321505	10-53x	ZS325495	10-30x		
EC306419	5-C4	ES321274	5-SW3	SK321506	10-50	ZS379350	7-6		
EC306980	5-C74	ES321310	4-33	SK321507	10-52x	ZS379350	9-2		
EC306988	5-C8	ES655806	7-SW1	SM315737	10-25	ZS406416	10-31x		
EC313532	6-C5	ES665807	7-SW1	SP319449	10-32x	ZS417216	4-28		
EC313532	6-C12to14	ES665875	7-SW1	SP319450	10-33x	ZS419940	2-6		
EC313826	6-C8	ET301464	5-TR6	SP319451	10-34x	ZS422076	6-2		
EC314688	7-C9	ET307349	6-TR6	SP319452	10-36x	ZS422076	9-44x		
EC316230	7-C3	ET307349	7-TR1	SP319453	10-37x	ZS432843	3-14		
EC316230	7-C7	ET307349	9-1	SP321464	5-31	ZS447840	9-4		
EC316569	6-C1	ET308954	5-TR1	SP324592	10-35x	ZS462947	2-14		
EC321061	5-C25	ET310833	5-TR10,11	SZ319675	10-19	ZS477876	3-13x		
EC321061	5-C63	ET539133	5-TR8,9	SZ319676	10-20x	ZS499454	2-12		
EC321292	5-C32	ET554657	5-TR14	SZ321494	10-21	ZS521987	2-13		
EC321292	5-C56	ET554657	6-TR2	TC282396	4-9	ZS524812	2-10		
EC321302	7-C9	ET603257	5-TR2	TC305728	9-39	ZS590804	2-11		
EC321339	5-C43	ET638504	5-TR7	TC319723	4-1	ZS608220	10-12		
EC321340	5-C44	ET639437	5-TR3to5	TC319724	4-63	ZW260370	9-47x		
EC321341	5-C45	ET639437	5-TR13	TC321362	4-37	ZW260370	10-18x		
EC321342	5-C46	ET639437	6-TR1	TC321363	4-38x	ZW263946	5-5		
EC321343	6-C9	ET639437	6-TR3to5	TC321364	4-39	ZW269335	3-5		
EC321349	5-C49	ET655356	5-TR12	TC321365	4-40x	ZW270088	10-17		
ED306109	6-D11	EV314968	5-VR10	TC321367	4-41	ZW270101	4-24		
ED308952	5-D1	EV315412	5-VR3	TC321368	4-42x	ZW270123	4-47		
ED308952	5-D6,7	EV315413	5-VR4	TC321369	4-43	ZW273802	5-7		
ED308952	5-D10	EV315413	5-VR7,8	TC321370	4-44x	ZW290283	9-37		
ED308952	6-D15,16	EV315414	5-VR9	TC321415	4-50	ZW305006	10-22x		
ED310387	6-D12	EV321263	9-43	TC321478	10-5x	ZW305546	4-19		
ED313846	7-D2	EV321264	5-VR1	TC321479	10-4	ZW305546	4-67		
ED315960	7-D1	EV322416	5-VR5,6	TC321480	10-7x	ZW313501	2-4		
ED321269	9-42	EW305691	9-9x	TC321481	10-6	ZW315929	10-40		
ED321347	9-48	EW306427	9-8x	TC321483	10-8	ZW321317	4-64		
ED560913	5-D2to5	EW306428	9-7	TC321486	10-13	ZW321393	4-12		
ED560913	5-D8,9	EW313882	9-10x	TC321488	10-15	ZW321424	3-9		
ED560913	5-D11	EW313883	9-12x	ZG289236	2-3	ZW321437	3-11		
ED560913	6-D1to10	EW313884	9-11x	ZG305641	9-36	ZW321437	4-20		
ED560913	6-D13,14	EZ631945	9-5	ZG312920	4-58	ZW321437	4-66		
EF300588	9-27x	FE315742	2-5	ZG312926	4-2	ZW340648	4-17		
EF309387	9-23	HP319079	2-9	ZG312943	4-4	ZW340648	4-36		
EF309388	9-22	HZ309128	2-2	ZG312945	2-18	ZW357164	2-20		
EF309391	9-25x	HZ316252	2-8	ZG318228	4-52	ZW381644	4-11		
EF310229	9-26x	MB282778	3-2	ZG321303	4-68	ZW413267	9-34		
EF315334	9-24x	MB321389	3-7	ZG321373	4-3	ZW460787	4-55		
EF321323	9-21	MB321391	3-6x	ZG321384	4-22	ZW548010	10-45x		
EF593706	9-28x	MB321392	4-29	ZG321411	4-25	ZW550697	10-11x		
EF601942	9-29x	MB510164	9-35	ZG321416	4-51	ZW653163	4-56		
EI213390	6-IC1	MC321324	4-27x	ZG321430	4-45				
EI304657	6-IC3	MC321325	4-26	ZG321431	4-46				
EI306141	5-IC2	MI319686	3-8	ZG321487	10-14				

SECTION 3

SCHEMATIC DIAGRAM

1. SCHEMATIC DIAGRAM OF ICs
2. GX-M10 NO. 1582252A SCHEMATIC DIAGRAM

NE545B

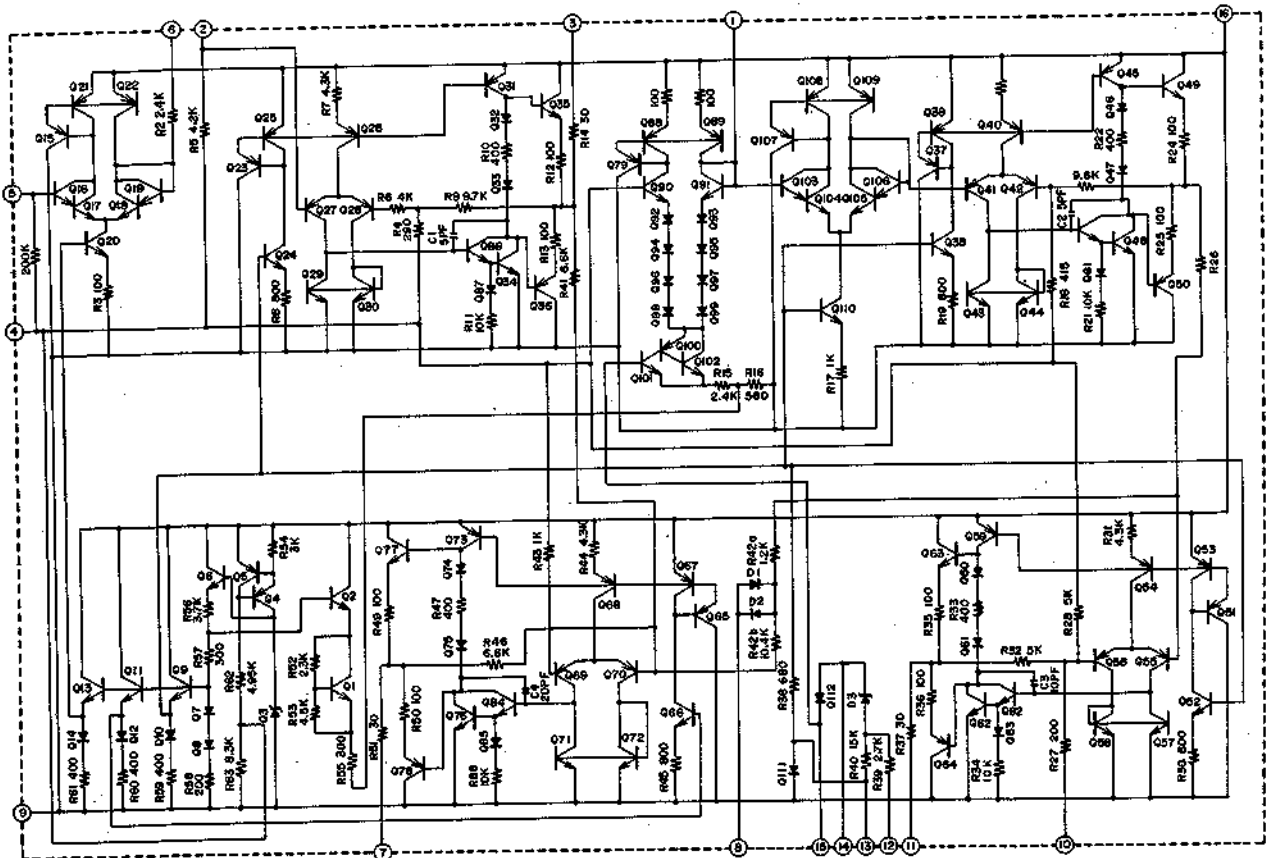

LA4170

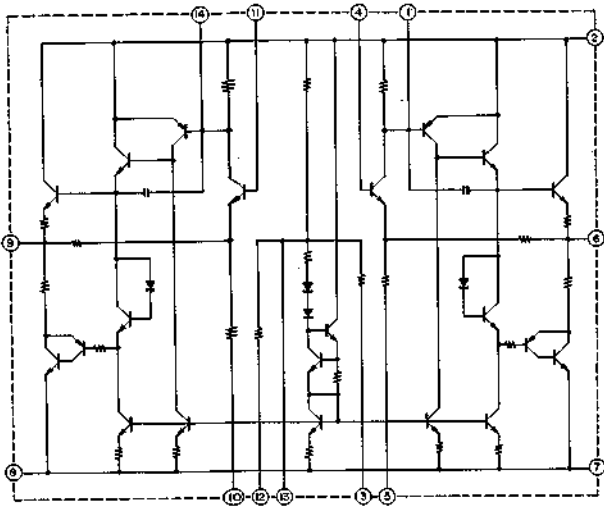

MJM4558

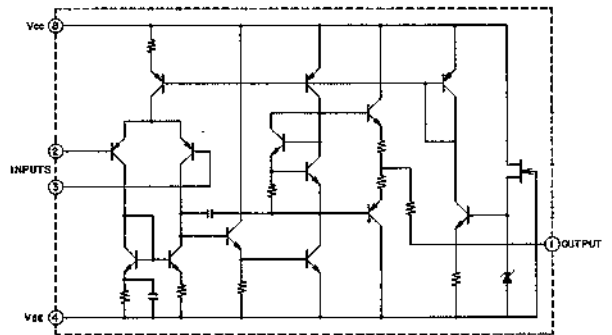
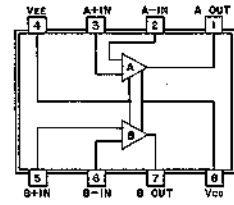

HA12019

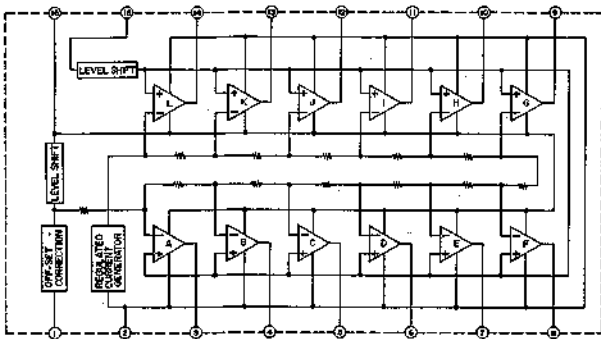

TC4011BP

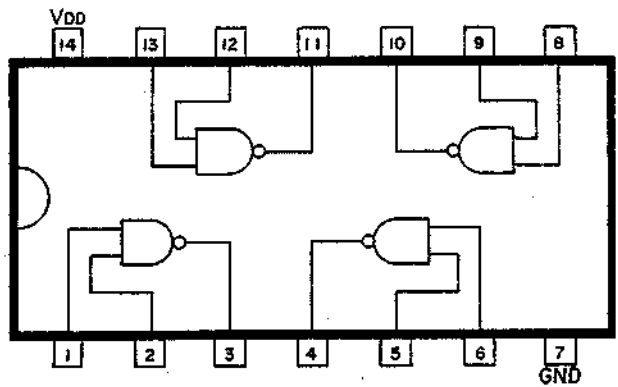

MSM5953RS

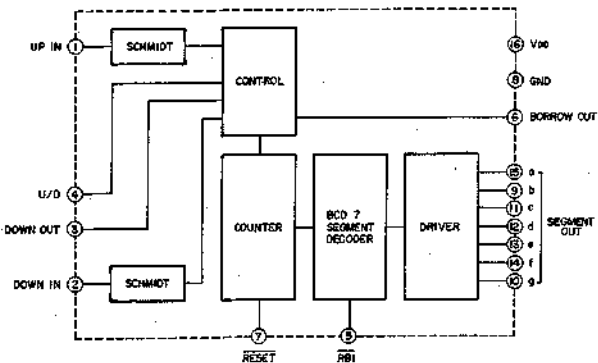

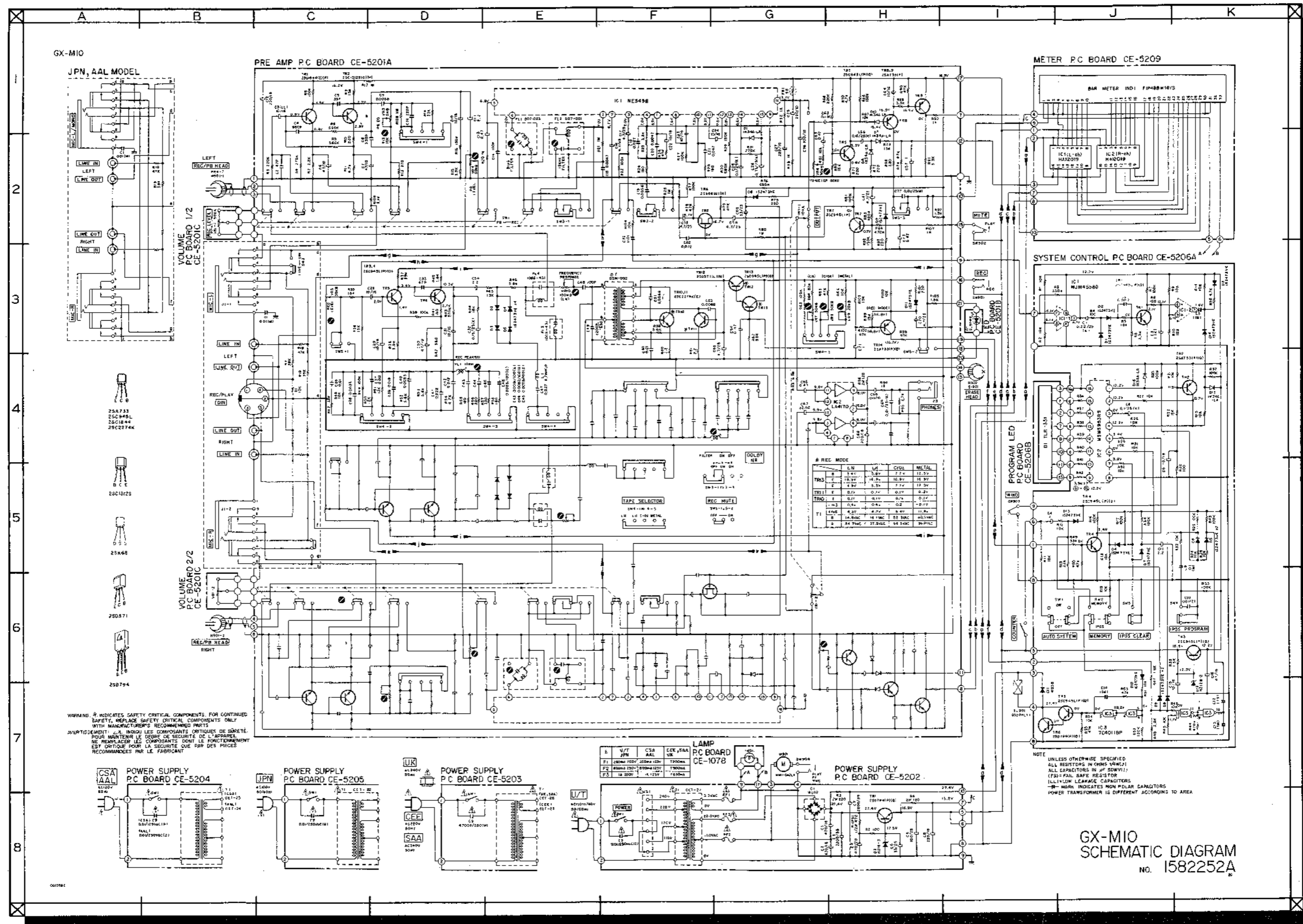

GX-M10

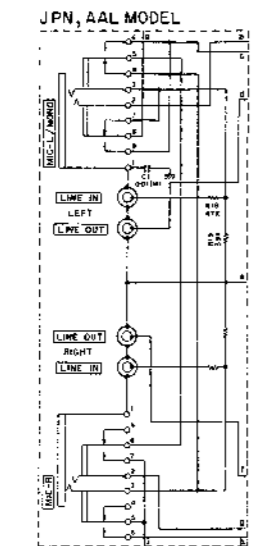

PRE AMP P.C BOARD CE-5201A

METER P.C BOARD CE-5209

SYSTEM CONTROL P.C BOARD CE-5206A

PROGRAM LED P.C BOARD CE-5206B

VOLUME P.C BOARD 1/2 CE-5201C

VOLUME P.C BOARD 2/2 CE-5201C

WARNING: * INDICATES SAFETY CRITICAL COMPONENTS FOR CONTINUED SAFETY. REPLACE SAFETY CRITICAL COMPONENTS ONLY WITH MANUFACTURER'S RECOMMENDED PARTS.
 AVERTISSEMENT: * A INDIQUE LES COMPOSANTS CRITIQUES DE SÉCURITÉ. POUR MAINTENIR LE DEGRÉ DE SÉCURITÉ DE L'APPAREIL, NE REMPLACER LES COMPOSANTS QUE LE FONCTIONNEMENT EST CRITIQUE POUR LA SÉCURITÉ QUE PAR DES PIÈCES RECOMMANDÉES PAR LE FABRICANT.

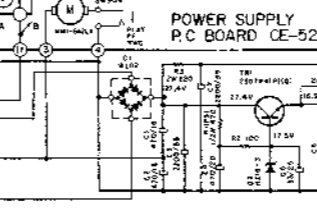
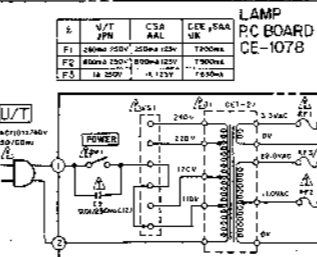
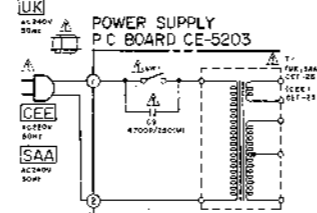
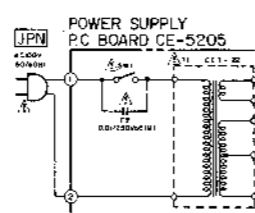
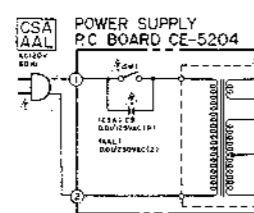

REC MODE

TRD	C.W.	L.F.	C.W.	METAL
B	3.4V	5.8V	7.7V	12.5V
C	10.0V	14.2V	16.9V	18.9V
E	1.2V	5.3V	7.7V	13.2V
F	0.1V	0.1V	0.1V	0.2V
G	1.1V	7.0V	0.8V	0.2V
H	4.2V	4.2V	4.4V	13.4V
I	14.5V	16.7V	22.5V	22.5V
J	24.7V	27.3V	28.5V	28.5V

NOTE: UNLESS OTHERWISE SPECIFIED, ALL RESISTORS IN OHMS (W/M/C). ALL CAPACITORS IN μF (20WV). (FS) = FAIL SAFE RESISTOR. (LL) = LOW LEAKAGE CAPACITORS. * MARK INDICATES NON-POLAR CAPACITORS. POWER TRANSFORMER IS DIFFERENT ACCORDING TO AREA.

GX-M10 SCHEMATIC DIAGRAM NO. 1582252A