

AKAI SERVICE MANUAL

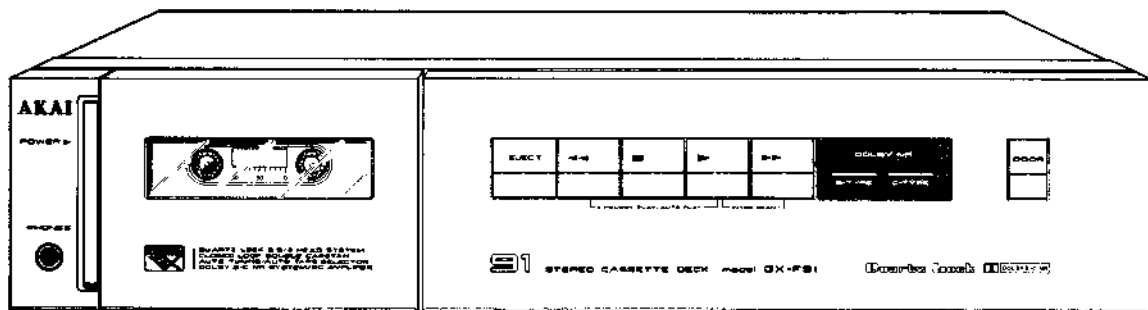

STEREO CASSETTE DECK

MODEL **GX-F91**



STEREO CASSETTE DECK

MODEL GX-F91

THIS MANUAL IS APPLICABLE TO BOTH SILVER
AND PEARL SHADOW PANEL MODELS

SECTION 1	CIRCUIT OPERATION DESCRIPTION	3
SECTION 2	SERVICE MANUAL	23
SECTION 3	PARTS LIST	57
SECTION 4	SCHEMATIC DIAGRAM	76

SAFETY INSTRUCTIONS

SAFETY CHECK AFTER SERVICING

Confirm the specified insulation resistance between power cord plug prongs and externally exposed parts of the set is greater than 10 Mohms, but for equipment with external antenna terminals (tuner, receiver, etc.) and is intended for **C** or **A**, specified insulation resistance should be more than 2.2 Mohms (ground terminals, microphone jacks, headphone jacks, line-in-out jacks etc.)

PRECAUTIONS DURING SERVICING

1. Parts identified by the **Δ** symbol parts are critical for safety.
Replace only with parts number specified.
2. In addition to safety, other parts and assemblies are specified for conformance with such regulations as those applying to spurious radiation. These must also be replaced only with specified replacements.
Examples: RF converters, tuner units, antenna selector switches, RF cables, noise blocking capacitors, noise blocking filters, etc.
3. Use specified internal wiring. Note especially:
 - 1) Wires covered with PVC tubing
 - 2) Double insulated wires
 - 3) High voltage leads
4. Use specified insulating materials for hazardous live parts. Note especially:
 - 1) Insulation Tape
 - 2) PVC tubing
 - 3) Spacers (Insulating Barriers)
 - 4) Insulation sheets for transistors
5. When replacing AC primary side components (transformers, power cords, noise blocking capacitors, etc.), wrap ends of wires securely about the terminals before soldering.

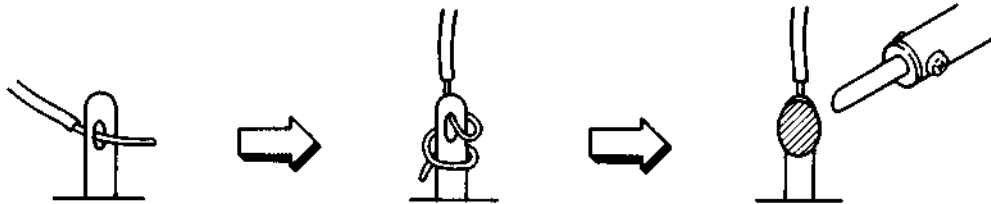

6. Observe that wires do not contact heat producing parts (heatsinks, oxide metal film resistors, fusible resistors, etc.).
7. Check that replaced wires do not contact sharp edged or pointed parts.
8. Also check areas surrounding repaired locations.
9. Use care that foreign objects (screws, solder droplets, etc.) do not remain inside the set.

SECTION 1

CIRCUIT OPERATION DESCRIPTION

TABLE OF CONTENTS

I.	GX-F91 SYSCON CIRCUIT FUNCTIONS	4
	1. GX-91 SYSCON BLOCK DIAGRAM	4
	2. MEANING EACH TERMINAL OF CPU (LM6402H-063)	5
	3. CONNECTION OF EACH TERMINAL OF IC (LC7800) FOR EXPANDING GX-F91 INPUT PORT	6
II.	AUTO TUNING SYSTEM	7
	1. AUTO TUNING BLOCK DIAGRAM	7
	2. MI-COM IN/OUT PORT	8
	3. DESCRIPTION OF THE TUNING MI-COM IN/OUT PORTS (MB8841-649M)	9
	4. AUTO TUNING SYSTEM DESCRIPTION	11
III.	AMPLIFIER	20
	1. AMP BLOCK DIAGRAM	20
	2. PB HEAD EQ AMP	22
	3. TAPE/SOURCE MONITOR SWITCHING AND MUTE CIRCUITS	21



**3. CONNECTION OF EACH TERMINAL OF IC (LC 7800)
FOR EXPANDING GX-F91 INPUT PORT**

PIN	Items connected to IC3	Items connected to IC4							
1	PLAY SW	MEMORY SW							
2	REC SW	IPLS SW							
3	FF SW	OPEN ("H") (No connection)							
4	REW SW	R104 of cam motor drive circuit							
5	EJECT SW	TIMER PLAY SW							
6	STOP SW	TIMER REC SW							
7	AUTO FADER SW	ANTIREC SW							
8	AUTO MUTE SW	+5V (No connection)							
9	REC CANCEL SW	+5V (No connection)							
10	AUTO LOADING SW	+5V (No connection)							
11	RESET SW	+5V (No connection)							
12	TAPE/TIME SW	+5V (No connection)							
13	GND	MICON PIN2							
14	GND	GND							
15	C-stop signal of cam motor drive circuit								
16	TUNING MICON PIN 35	(For Mechacontrol Signal When TUNING)							
17	TUNING MICON PIN 36								
18	TUNING MICON PIN 3								
Mechacontrol signal from TUNING MICON									
	TUNING MICON PIN	SYSCON MICON PIN	NON OPERATION	STOP	FF	REW	REC/PLAY	REC/PAUSE	TEST OFF
	35 (O ₀) MECHACON I	34 (A1)	L	H	L	H	L	H	L
	36 (O ₁) MECHACON II	35 (A2)	L	L	H	H	L	L	L
	3 (O ₂) MECHACON III	36 (A3)	L	L	L	L	H	H	L
19			SYSCON MICON PIN 40 (B3)						
20			SYSCON MICON PIN 39 (B2)						
21			SYSCON MICON PIN 38 (B1)						
22			SYSCON MICON PIN 37 (B0)						
23			SYSCON MICON PIN 33 (A0)						
24			SYSCON MICON PIN 34 (A1)						
25			SYSCON MICON PIN 35 (A2)						
26			SYSCON MICON PIN 36 (A3)						
27	+5V								+5V
28	MICON PIN 2								+5V

II. AUTO TUNING SYSTEM

1. AUTO TUNING BLOCK DIAGRAM

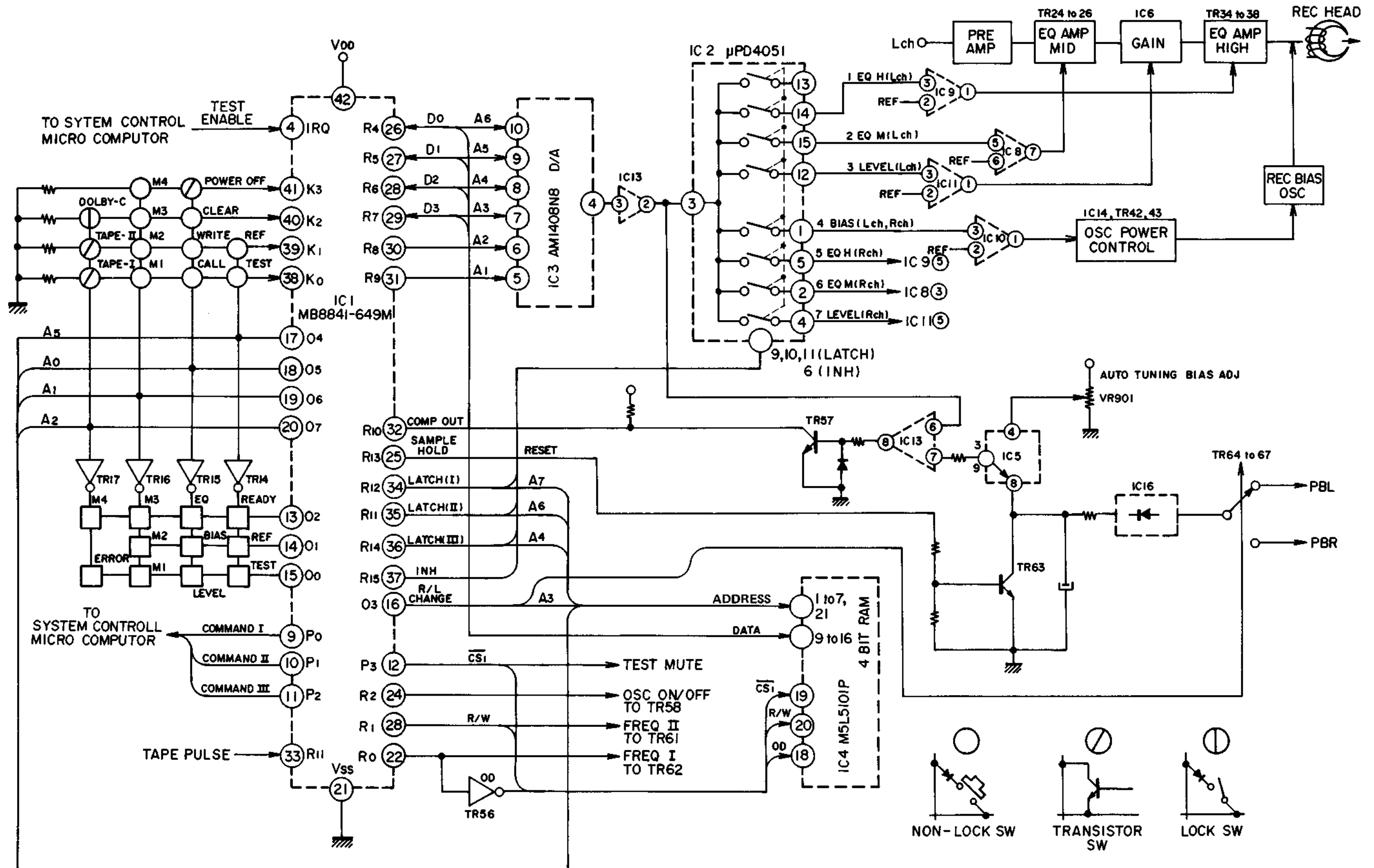

Fig. 1-3 Auto Tuning Block Diagram

2. MI-COM IN/OUT PORT

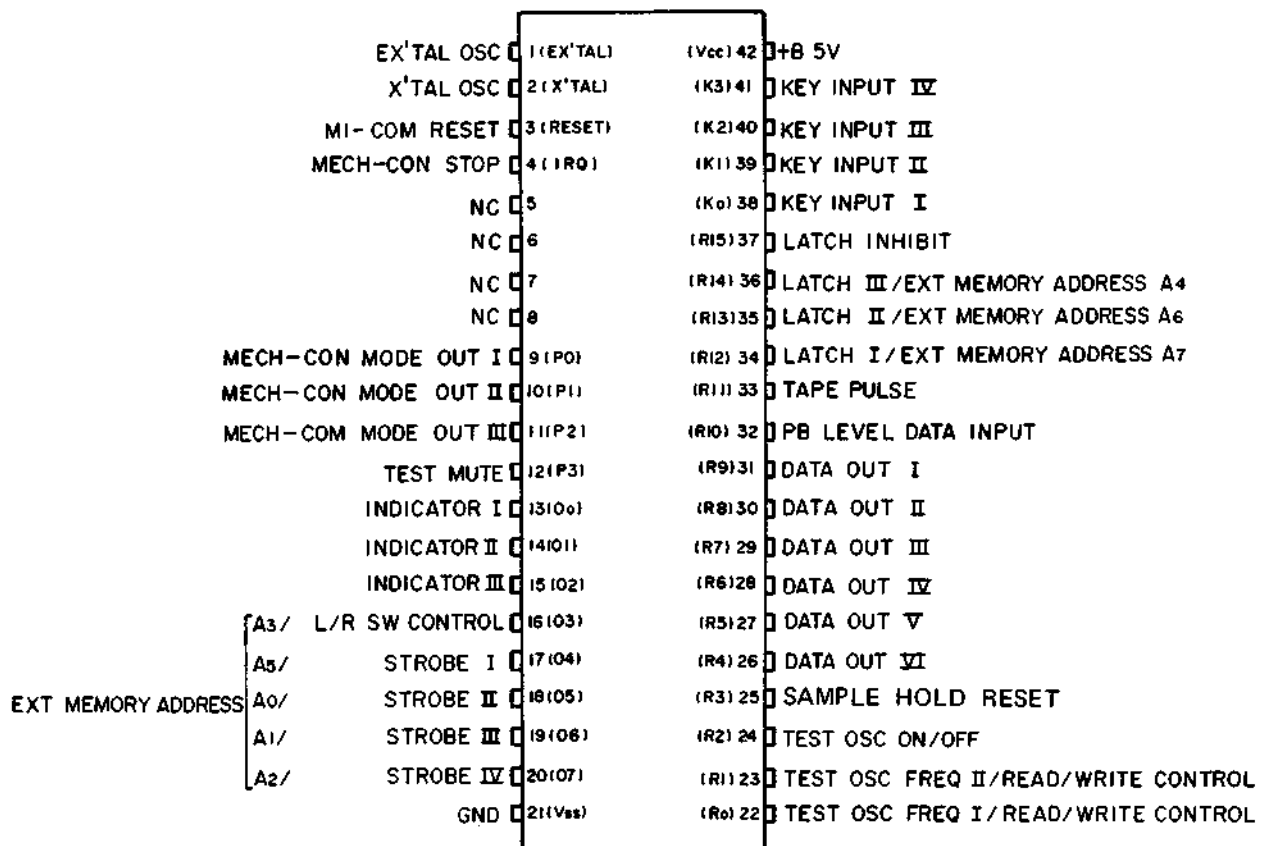
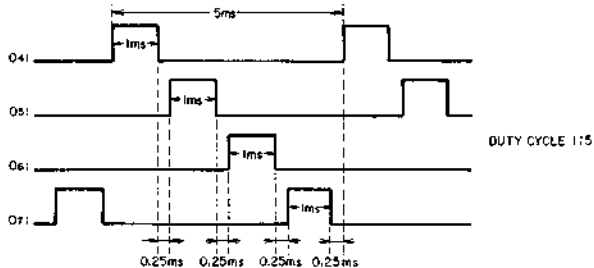

Fig. 1-4 IC1 MB8841-649M

3. DESCRIPTION OF THE TUNING MI-COM IN/OUT PORTS (MB8841-649M)

Pin No.	Port		Description																												
1 2	E X'TAL X'TAL	E X'tal X'tal	X'tal oscillator terminal. X'tal oscillator terminal																												
3	RESET	$\overline{\text{RESET}}$	Mi-Com Reset input terminal Reset when "L"																												
4	IRQ	TEST ENABLE	The STOP MODE signal is supplied from the MECH-CON. Normally is at "H" except that this is set to "L" 3 seconds after the power is turned on or when the STOP mode is established. Accepts Auto Tuning only when set to "L". Is at "H" during the auto tuning, which, however, will be stopped if "L" input is encountered.																												
5 6 7 8	SO SI SC/TO TC		Not in use.																												
9 10 11	P ₀ P ₁ P ₂	Mech-Con I Mech-Con II Mech-Con III	The mech. control outputs I, II and III allow 6 different modes (0) through (5) as shown in the table below. Without the tuning operation, the MECH-CON outputs I, II and III are all "0", establishing the (0) mode (tuning OFF). During "TEST", any one of the modes (1) through (5) is established. When the test is complete, the mode (5), or (REC/PAUSE), is established, and then the mode (0), or (Tuning OFF), after the lapse of 50 msec. <table border="1" style="margin: 10px auto;"> <thead> <tr> <th>MODE</th> <th>(0) Tuning OFF</th> <th>(1) STOP</th> <th>(2) FF</th> <th>(3) RWD</th> <th>(4) REC/PB</th> <th>(5) REC/ PAUSE</th> </tr> </thead> <tbody> <tr> <td>Mech-Con I</td> <td>0</td> <td>1</td> <td>0</td> <td>1</td> <td>0</td> <td>1</td> </tr> <tr> <td>Mech-Con II</td> <td>0</td> <td>0</td> <td>1</td> <td>1</td> <td>0</td> <td>0</td> </tr> <tr> <td>Mech-Con III</td> <td>0</td> <td>0</td> <td>0</td> <td>0</td> <td>1</td> <td>1</td> </tr> </tbody> </table>	MODE	(0) Tuning OFF	(1) STOP	(2) FF	(3) RWD	(4) REC/PB	(5) REC/ PAUSE	Mech-Con I	0	1	0	1	0	1	Mech-Con II	0	0	1	1	0	0	Mech-Con III	0	0	0	0	1	1
MODE	(0) Tuning OFF	(1) STOP	(2) FF	(3) RWD	(4) REC/PB	(5) REC/ PAUSE																									
Mech-Con I	0	1	0	1	0	1																									
Mech-Con II	0	0	1	1	0	0																									
Mech-Con III	0	0	0	0	1	1																									
12	P ₃	TEST MUTE	Is at "H" during "TEST", causing the PB output to be muted. Also, during "TEST", the "H" output places the external memory (IC4) in a non-selective state ($\overline{\text{CS}}_1$) Mutes the TEST signal output with a mode other than the TEST mode.																												
13 14 15	O ₀ O ₁ O ₂	INDICATOR I INDICATOR II INDICATOR III	Are indicator outputs that provide dynamic indicator display in response to strobe signals from Pins ⑰ ~ ⑳ (O ₄ ~ O ₇). The "L" outputs cause the indicators to come on.																												
16	O ₃	L/R SWITCH CONTROL	Causes switching between Lch and Rch for the PB signal to the level level detection circuit.																												
17 18 19 20	O ₄ O ₅ O ₆ O ₇	STROBE I STROBE II STROBE III STROBE IV	Causes a 4 bit signal to be output through strobe oscillation with coordinated timing. This signal permits dynamic display of each key input and indicator output. 																												

Pin No.	Port		Description																																													
21	V _{SS}	V _{SS}	GND																																													
22 23	R ₀ R ₁	TEST OSC FREQ I TEST OSC FREQ II	Provides the output signal that controls the oscillation frequency of the TEST signal. <table border="1" style="margin-left: 20px;"> <tr> <td></td> <td>1 kHz</td> <td>7 kHz</td> <td>13 kHz</td> <td>15 kHz</td> </tr> <tr> <td>R₀</td> <td>0</td> <td>1</td> <td>0</td> <td>1</td> </tr> <tr> <td>R₁</td> <td>0</td> <td>0</td> <td>1</td> <td>1</td> </tr> </table>		1 kHz	7 kHz	13 kHz	15 kHz	R ₀	0	1	0	1	R ₁	0	0	1	1																														
	1 kHz	7 kHz	13 kHz	15 kHz																																												
R ₀	0	1	0	1																																												
R ₁	0	0	1	1																																												
	R ₀	READ OUT CONTROL (OD)	Controls the IC4's data read output. "H" : No Read "L" : Read OK.																																													
	R ₁	READ/WRITE CONTROL	Controls the external memory (IC4). "H" : Read "L" : Write																																													
24	R ₂	TEST OSC ON/OFF	Provides the control signal for oscillating the TEST signal during the TEST mode. "H" : TEST OSC "ON" "L" : TEST OSC "OFF"																																													
25	R ₃	SAMPLE HOLD RESET	Discharges the condenser C65 that sample-holds the PB output that has been integrated. Note that this is done on a per-test basis. "H" : Reset																																													
26 27 28 29 30 31	R ₄ R ₅ R ₆ R ₇ R ₈ R ₉	DATA OUT I DATA OUT II DATA OUT III DATA OUT IV DATA OUT V DATA OUT VI	Provides 6 bit signals to generate 64 different step signals. The 64 signals are subjected to D/A conversion for tuning at each level.																																													
32	R ₁₀	PB LEVEL DATA INPUT	The PB output signal is detected and then compared with the reference Voltage. The inverted signal from the comparator (IC13) is supplied to the Mi-Com. Based on this signal, the PB level is detected for subsequent data processing by the Mi-Com.																																													
33	R ₁₁	$\overline{\text{INT}}$	Provides the pulse input (TAPE PULSE input) required to rewind back to the tuning start point.																																													
34 35 36	R ₁₂ R ₁₃ R ₁₄	LATCH I LATCH II LATCH III	Provides 3 bit signals to manipulate the 8 circuits switch (IC2) separately and route the D/A converted DATA OUT (Mi-Com outputs R ₄ ~ R ₉ 6 bits) through time sharing. $(\text{Bias}) + [(\text{Level}) + (\text{EQ H}) + (\text{EQ M})] \times (\text{L} + \text{R}) = 7$ <table border="1" style="margin-left: 20px;"> <tr> <td></td> <td colspan="2">BIAS</td> <td colspan="2">EQ H</td> <td colspan="2">EQ M</td> <td colspan="2">LEVEL</td> </tr> <tr> <td></td> <td>R</td> <td>L</td> <td>R</td> <td>L</td> <td>R</td> <td>L</td> <td>R</td> <td></td> </tr> <tr> <td>R₁₂</td> <td>0</td> <td>1</td> <td>1</td> <td>0</td> <td>0</td> <td>1</td> <td>1</td> <td></td> </tr> <tr> <td>R₁₃</td> <td>0</td> <td>0</td> <td>0</td> <td>1</td> <td>1</td> <td>1</td> <td>1</td> <td></td> </tr> <tr> <td>R₁₄</td> <td>1</td> <td>0</td> <td>1</td> <td>0</td> <td>1</td> <td>0</td> <td>1</td> <td></td> </tr> </table>		BIAS		EQ H		EQ M		LEVEL			R	L	R	L	R	L	R		R ₁₂	0	1	1	0	0	1	1		R ₁₃	0	0	0	1	1	1	1		R ₁₄	1	0	1	0	1	0	1	
	BIAS		EQ H		EQ M		LEVEL																																									
	R	L	R	L	R	L	R																																									
R ₁₂	0	1	1	0	0	1	1																																									
R ₁₃	0	0	0	1	1	1	1																																									
R ₁₄	1	0	1	0	1	0	1																																									
37	R ₁₅	LATCH INHIBIT	Makes invalid all signals appearing at R ₁₂ ~ R ₁₄ and causes the switch (IC2) controlled by these signals to be opened.																																													
38 39 40 41	K ₀ K ₁ K ₂ K ₃	KEY INPUT I KEY INPUT II KEY INPUT III KEY INPUT IV	Key switch inputs. Type of tape and Dolby ON/OFF detection input.																																													

Pin No.	Port		Description
42	Vcc	Vcc	+5V Power Supply
16	O ₃	} EXT MEMORY ADDRESS	A ₃
17	O ₄		A ₅
18	O ₅		A ₀
19	O ₆		A ₁
20	O ₇		A ₂
34	R ₁₂		A ₇
35	R ₁₃		A ₆
36	R ₁₄		A ₄
			} External memory addresses (IC4)

4. AUTO TUNING SYSTEM DESCRIPTION

The reference tape being used by AKAI has characteristics that are most common with tapes currently available on the market.

With due consideration given to the difference in characteristics between tapes, it has been found that correction of ± 9.6 dB can be made with reference to the center value by providing 64 steps (0.3 dB per step) and that a variety of tapes can be supported by performing tape tuning.

The auto tuning involves:

- 1) Level adjustment
- 2) Bias adjustment
- 3) Equalizer Middel (EQM) adjustment
- 4) Equalizer High (EQH) adjustment

The level and equalizer adjustments are made in 64 steps (0.3 dB per step).

4-1. Auto Tuning Procedure

- 1) Insert the tape.
- 2) Detect the pack and tape type (auto tape selector).
- 3) The TEST start switch ON.
- 4) Detect the auto tuning bias level.
- 5) Perform REC/PB for the reference signal and determine whether the portion of tape is leader tape or one coated with magnetic material.
 - (a) In the case of leader tape, the error detection is followed by 64-count FF before tuning is started (REC PLAY MODE).
 - (b) If the portion is coated with magnetic mate-

rial, tuning is started immediately (REC PLAY MODE).

- 6) Make a coarse adjustment of REC/PB level. (Lch & Rch)
- 7) Make bias adjustment. (Rch only)
- 8) Make a fine adjustment of REC/PB level. (Lch and Rch).
- 9) Adjust the equalizer. (Lch and Rch)
- 10) If the above adjustments have been made satisfactorily, then rewind the tape back to the start point and establish the "READY standby" state via Rec/Pause.
- 11) If an error occurs during the tuning procedure, first perform the FF operation and then repeat the adjustments in 6) through 9).
- 12) If an error still occurs, then rewind the tape back to the start point and establish the STOP mode with ERROR displayed.

4-2. After Tuning

With "READY" displayed, it is possible to perform REC/PLAY directly with the data associated with the test.

The READY state is not cancelled, whichever operation key is depressed, unless the tape is changed or the TEST key is depressed again.

The data associated with the test can be written into any of the channels (memory 1 through 4).

Because of use of CMOS RAM and Ni-Cd batteries, the memory contents can be preserved for more than 20 days even if the power is turned off.

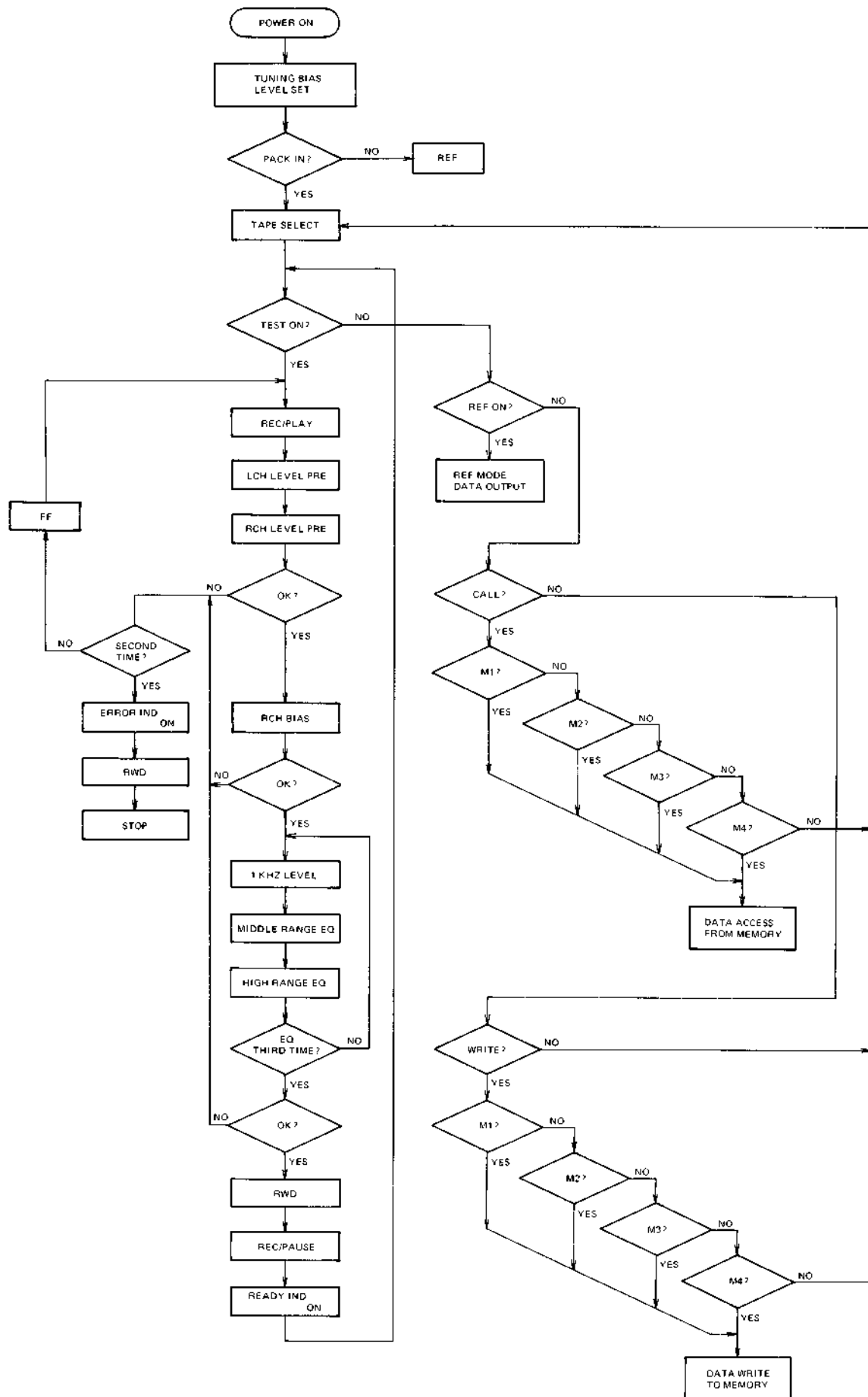

Fig. 1-5 Outline Flow Chart of Auto Tuning System

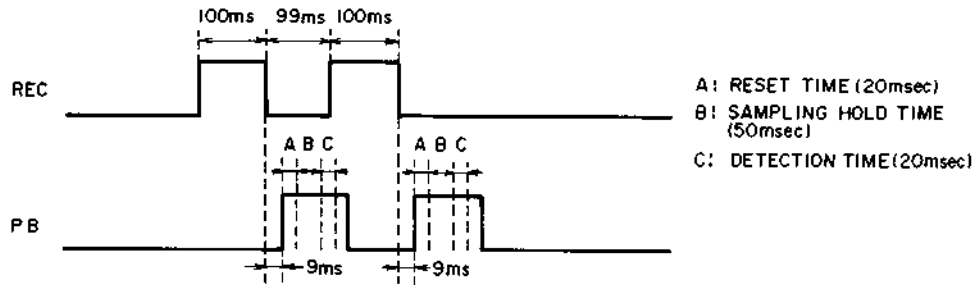

Fig. 1-6

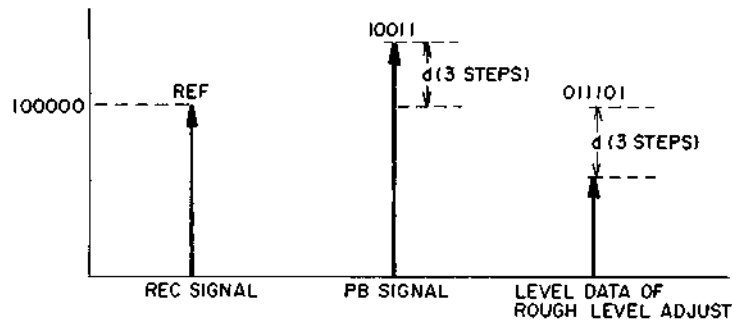

Fig. 1-7

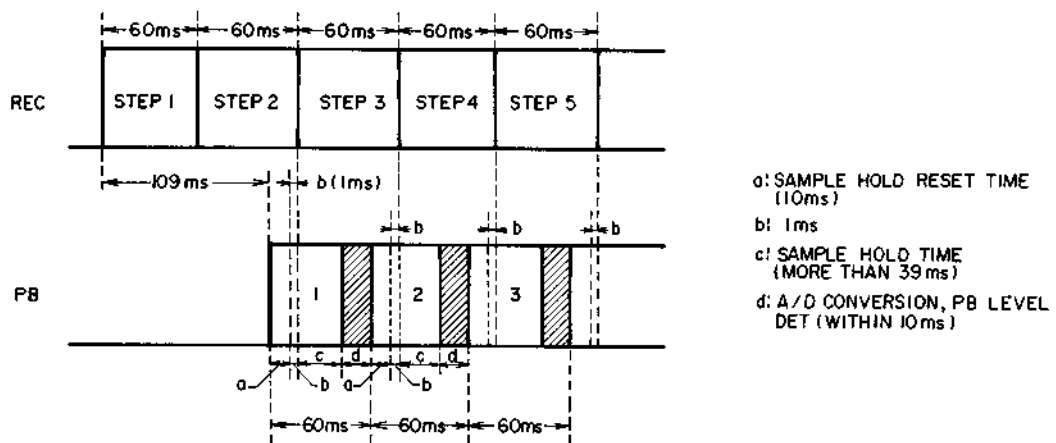

Fig. 1-8

4-3. Coarse Adjustment of REC/PB Levels (Refer to Figs. 1-6, 7)

The coarse level adjustment is made first on Lch and then on Rch.

A 1 kHz signal is recorded and played back with the standard REF value ($R_4 \sim R_9 : 100000, -27 \text{ VU}$), and the REC/PB level is subjected to A/D conversion and then compared with the REF value. The difference is then added to the REF value, the result of which is used as the REF value (level) for the next test. Figure 1-6 shows the REC/PB timing.

With the lapse of 109 msec after the recording, the PB output is made available. This output is compared in IC13 and then subjected to A/D conversion as test data to compute the difference (the number of steps) from 100000. For example, if the test data is 100011, the difference is 3 steps and thus it is necessary to set to the value (011101) which is the result of subtracting 3 (steps) from the recording

data. This data is routed via a switch (IC2) to IC11 to analog-hold it there. (See Figure 1-7.)

4-4. Bias Tuning (Refer to Figs. 1-8, 9, 10)

- 1) For bias tuning, a 1 kHz signal is recorded at a level obtained through the coarse level adjustment. The equalizer setting must be made with the reference data prior to recording.
- 2) For bias, continuous 16 step recording must be made at intervals of 4 steps, starting at 000000. One step takes 60 msec.
- 3) Figure 1-8 shows the REC/PB timing.

The REC bias data is switched 1 msec after the end of "a". The sample-holding of the PB signal takes place during "c". In "d", the PB level is subjected to A/D conversion, and the level associated with each step is determined within the Mi-Com.

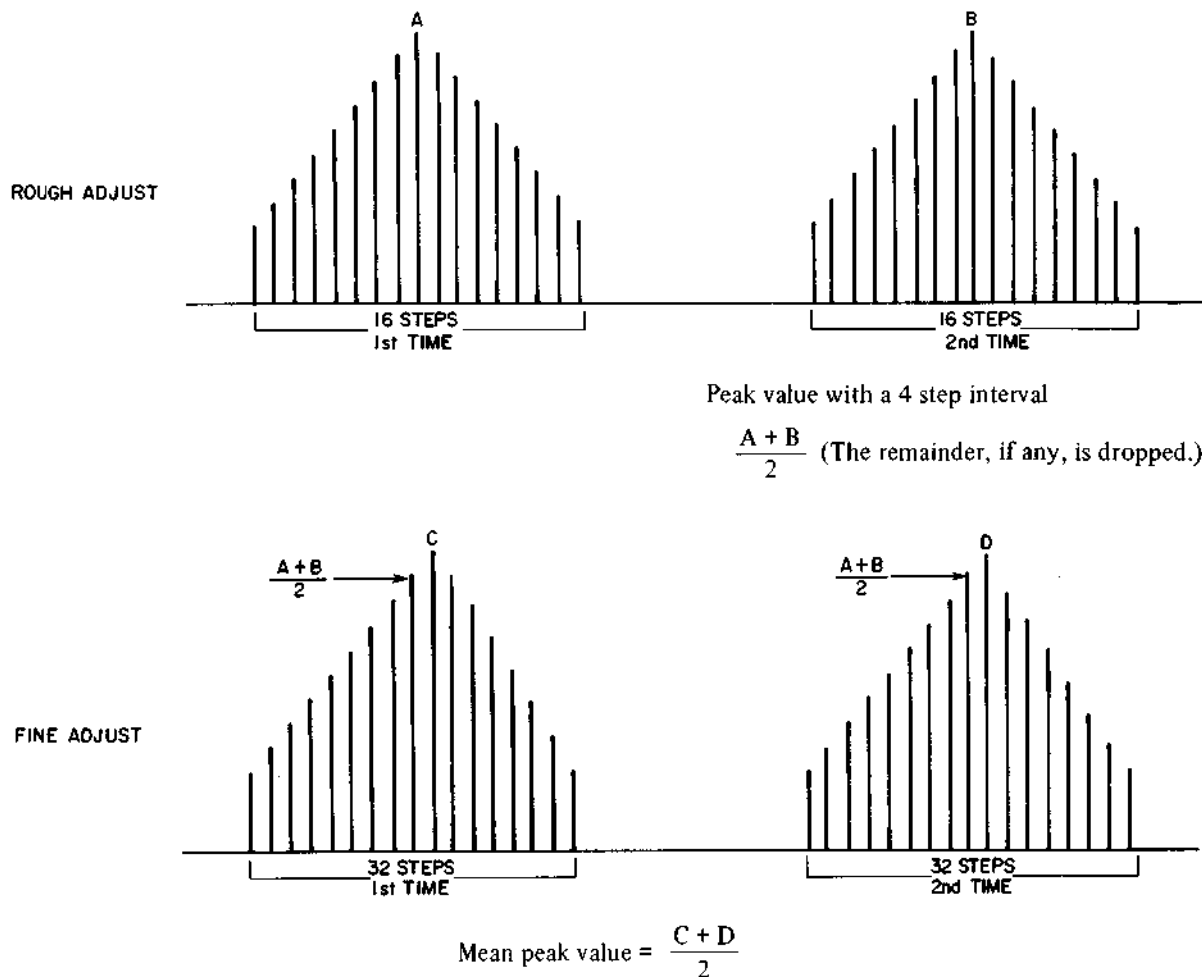

Fig. 1-9

- 4) The 16 step REC/PB is carried out twice and the average of the peak values is computed.
- 5) The range over which the amount of bias varies in ± 16 steps is determined, with the computed average value being at the center.
- 6) Recording and playback is made twice on a per-step basis, starting at the "lower" end of the variation range. Then, the average of the peak values in 32 steps is computed.
- 7) The value which is 4 steps higher than the data obtained by the fine adjustment is used as the bias setting.
- 8) Head Room adjustment system
The bias setting can be varied by means of the AT bias volume (VR 901) on the front panel. The AT bias set point is detected each time the test is started, thereby determining the number of excess steps. Figure 1-10 gives the change rate.

Change rate		Upon completion of tuning
Step	[%]	Step Over
+7	+21	10
+6	+18	9
+5	+15	8
+4	+12	7
+3	+9	6
+2	+6	5
+1	+3	4
0	0	4
-1	-3	4
-2	-6	3
-3	-9	2
-4	-12	1
-5	-15	0
-6	-18	-1
-7	-21	-2

If the change rate is 3% per step, then a change of $\pm 21\%$ can be achieved.

Fig. 1-10

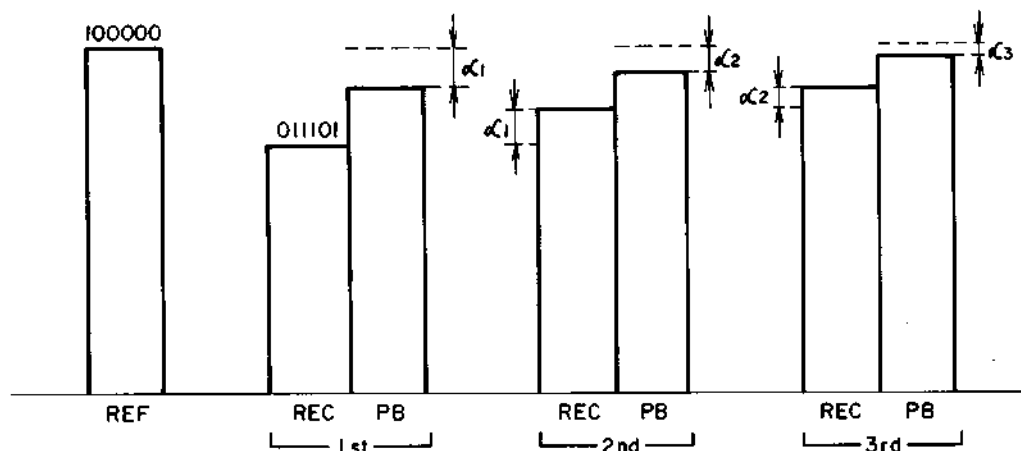

Fig. 1-11

4-5. Level Tuning (Refer to Fig. 1-11)

- 1) A 1 kHz signal is recorded and played back with the data (011101) obtained in the coarse level adjustment and the difference from the original REF value (100000) is determined, which is then added to the first recording level data. The result is then used as the second recording level data.
- 2) The same test is further repeated twice (i.e., a total of three tests are to be conducted.)
- 3) If after three tests the data obtained is outside the specified range, two additional tests need to be conducted.
- 4) If the data is still out of the specified range after the fifth recording/playback, an error is assumed.
- 5) If "Dolby ON" is detected, Δlevel is reduced to $1/2$, and $\Delta\text{level}/2$ is used as the amount of level correction (α).

4-6. Equalizer Tuning

- 1) The proper level must be set through recording and playback with 7 kHz (middle range), and 14 kHz (high range, with normal tape) or 15 kHz (high range, with CrO₂ or metal tape).

2) The REF value used is 100000.

3) In addition, the information in 4-5 "Level Tuning" also applies here.

4-7. Mute Circuit (During Tuning)

(Refer to Fig. 1-12)

When the test key is depressed, the Mi-Com enters the test mode with its pin ⑫ set to "H". This activates TR11 and TR12 on the meter drive PCB, which in turns on TR45 and TR47 (on the Pre Amp PCB) via D17 and D18, thereby causing the gates of TR44 and TR46 to be at negative voltage. As a result, both TAPE and SOURCE are shut off. Thus, the test signal is muted and therefore not made available at the LINE OUT during the test.

On the other hand, when pin ⑫ of Mi-Com goes to "H", TR1 of the Pre Amp is activated, causing the Rec input (Line/DIN) to go to ground. In addition, TR2 is turned on, deactivating TR3. As a result, the test signal from TEST OSC is supplied to the Rec Line Amp via R9.

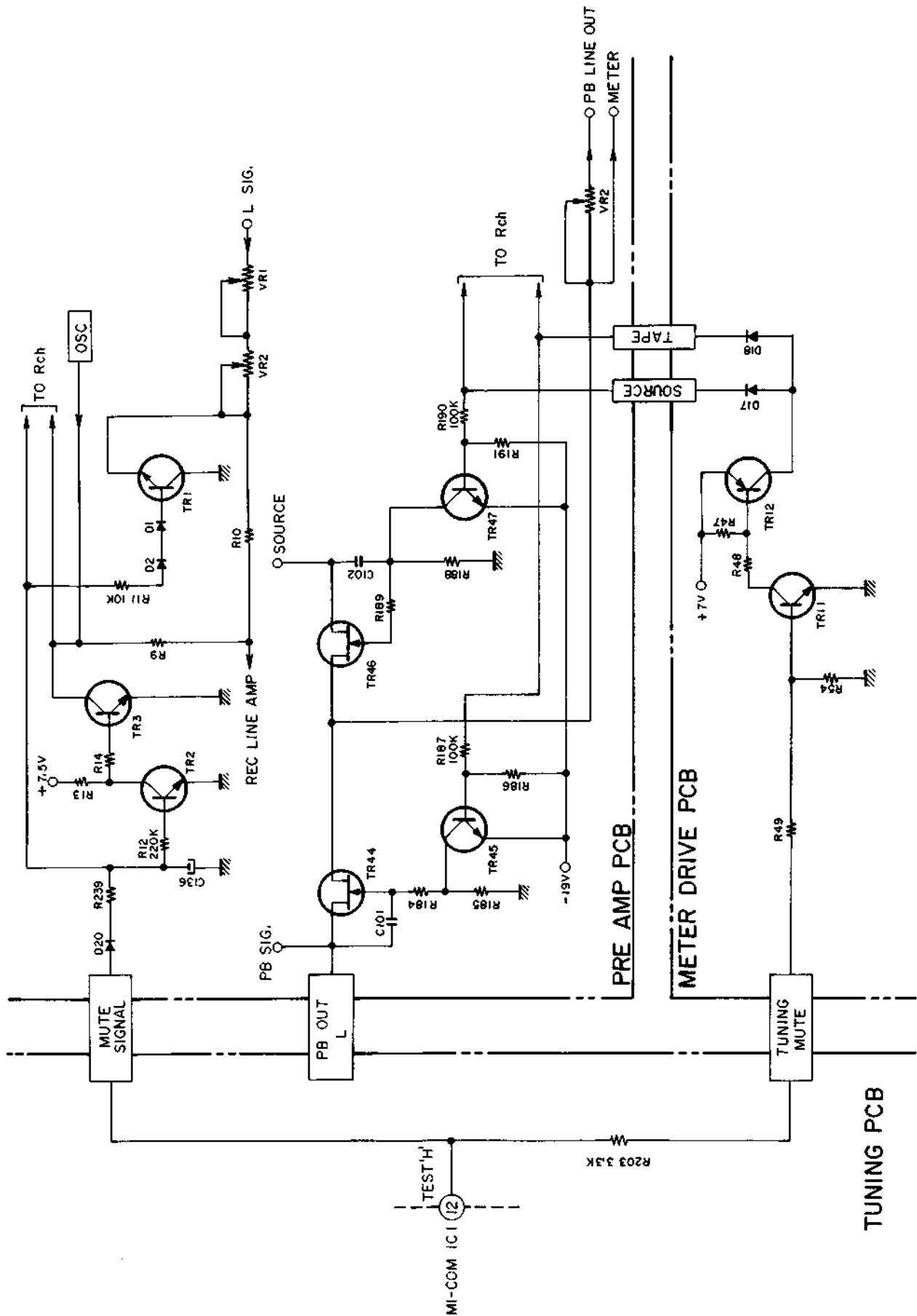

Fig. 1-12 Mute Circuit

4-8. Reference Signal Generation Circuit
(Refer to Fig. 1-13)

This circuit generates the reference signals (1K, 7K, 13K and 15K) at the time of tuning. The oscillation frequency of the TEST signal is controlled by way of pins 22 and 23 (OSC, FRQ I and II) of the Mi-Com. The 2 bit signal is used to

generate 1K, 7K, 13K and 15K. In the above truth table, "H" causes TRs 58, 61 and 62 to be activated. 13 kHz is used for NORMAL TEST, while 15 kHz is used for CrO₂ or METAL. The reference oscillation output level is adjusted by VR9.

No.		OSC stopped	1 kHz	7 kHz	13 kHz	15 kHz		
24	OSC ON/OFF	L	H	H	H	H	⇨	
22	FRQ I		L	L	H	H		TR58
23	FRQ II		L	H	L	H		TR61 TR62

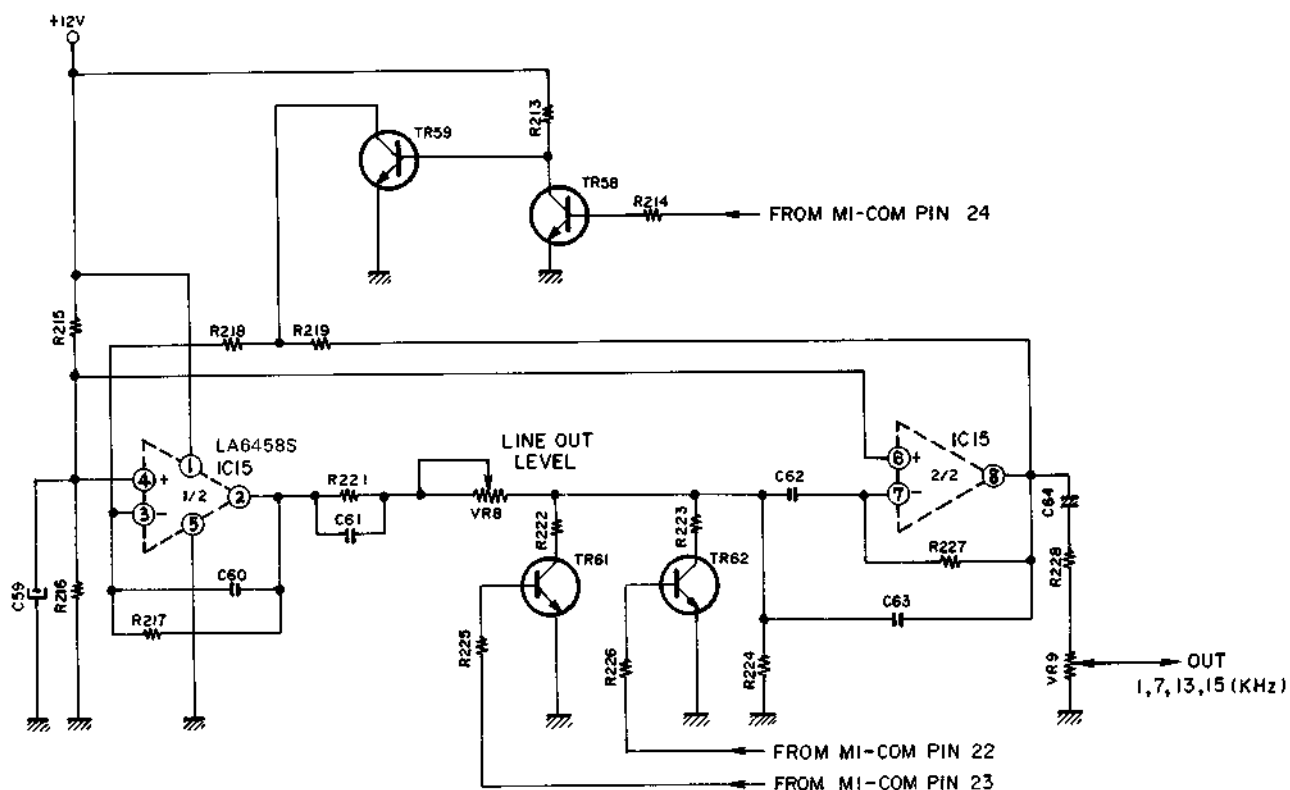

Fig. 1-13

4-9. A/D Conversion Circuit (Refer to Fig. 1-14)

The purpose of this circuit is to detect the REC/PB level at the time of auto tuning.

- 1) Switching between Lch and Rch is made by turning TR64 on/off by way of Mi-Com's pin ⑩ (L/R change-over SW control). (Lch : H ; Rch : L)
- 2) VR10 is for adjusting the A/D conversion level.

- 3) Pins ③ and ④ of IC5 are set to ON and the reference PB output level is supplied to pin ⑫ of the Mi-Com. Then, pins ⑧ and ⑨ of IC5 are set to ON and comparison is made with the previous data.
- 4) The PB output is integrated by the operation of TR63, and C65 is discharged for each test through resetting.

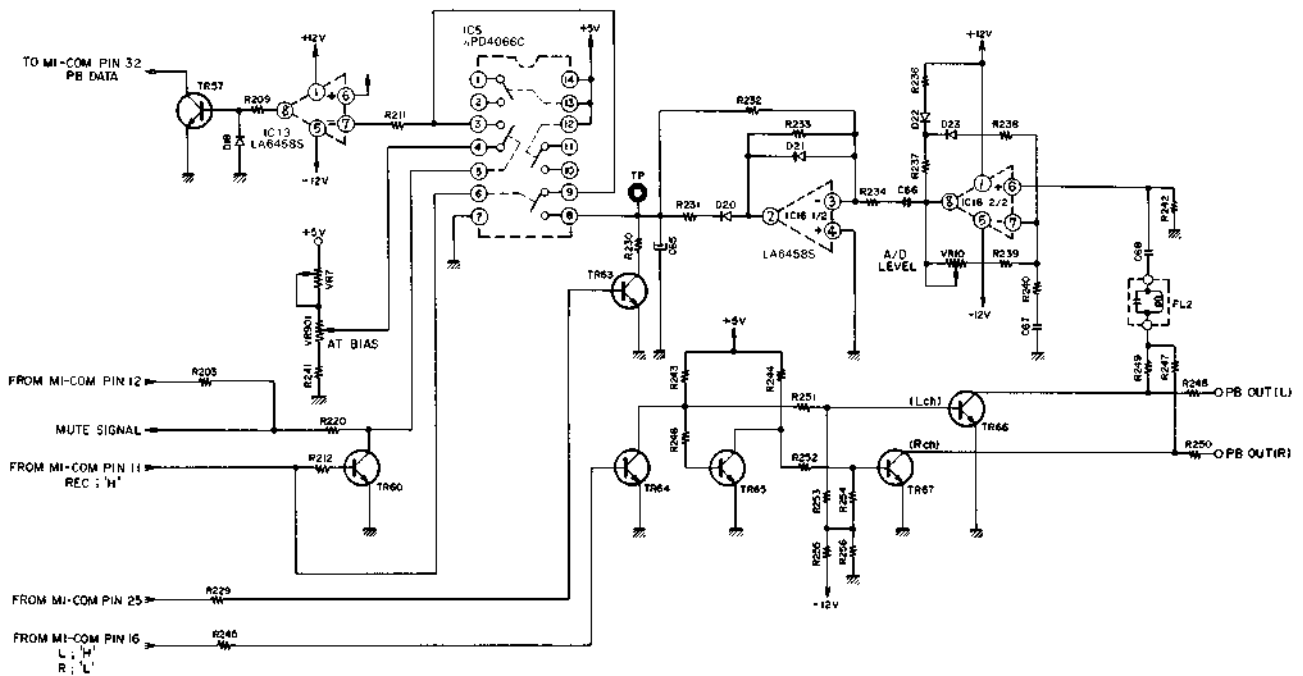

Fig. 1-14

4-10. Bias OSC Power Supply (Refer to Fig. 1-15)

The purpose of this circuit is to supply power to the bias OSC.

1) Bias

- (1) The AC component is removed by C50 and C51.
- (2) VR5 (METAL) and VR6 (CrO₂) are for adjusting the bias.
- (3) The output is killed by TR44. (OFF during REC mode)
- (4) Oscillator voltage is changed through control by TR43.

2) Erase head

- (1) Settings are made based on METAL. For NORMAL or CrO₂, voltage is changed by means of TR46 and TR48, respectively.
- (2) The output is killed by TR51. (OFF during REC mode)
- (3) Oscillator voltage is changed through control by TR50.

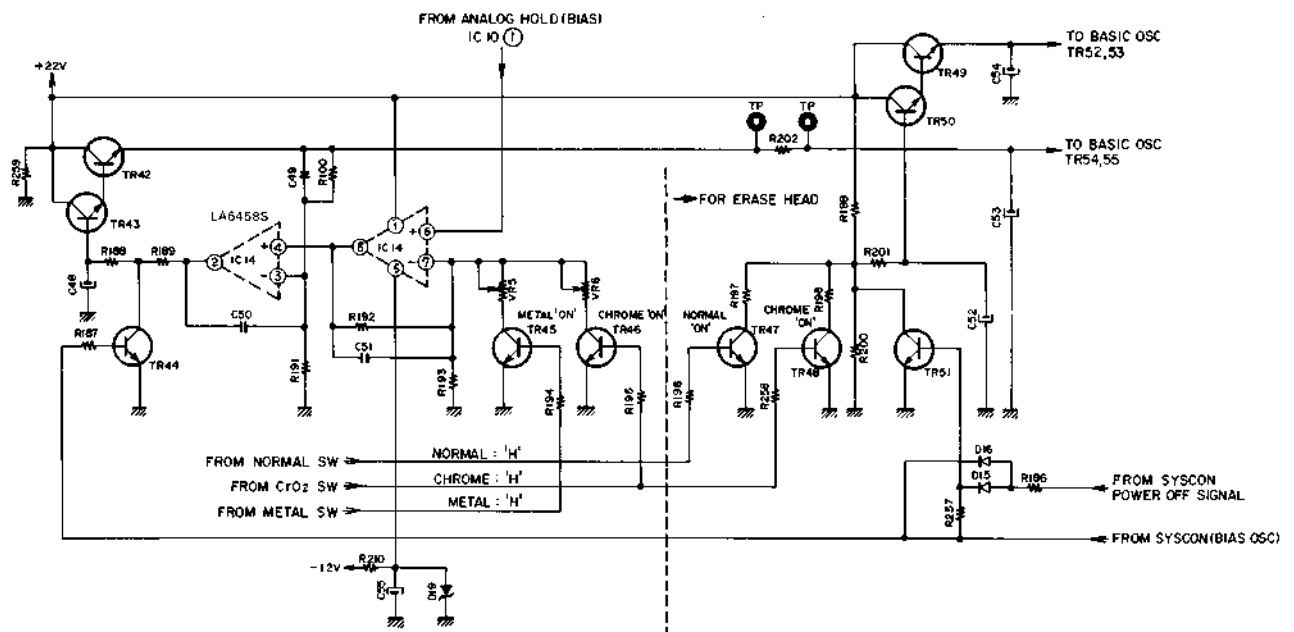

Fig. 1-15

III. AMPLIFIER

1. AMP BLOCK DIAGRAM

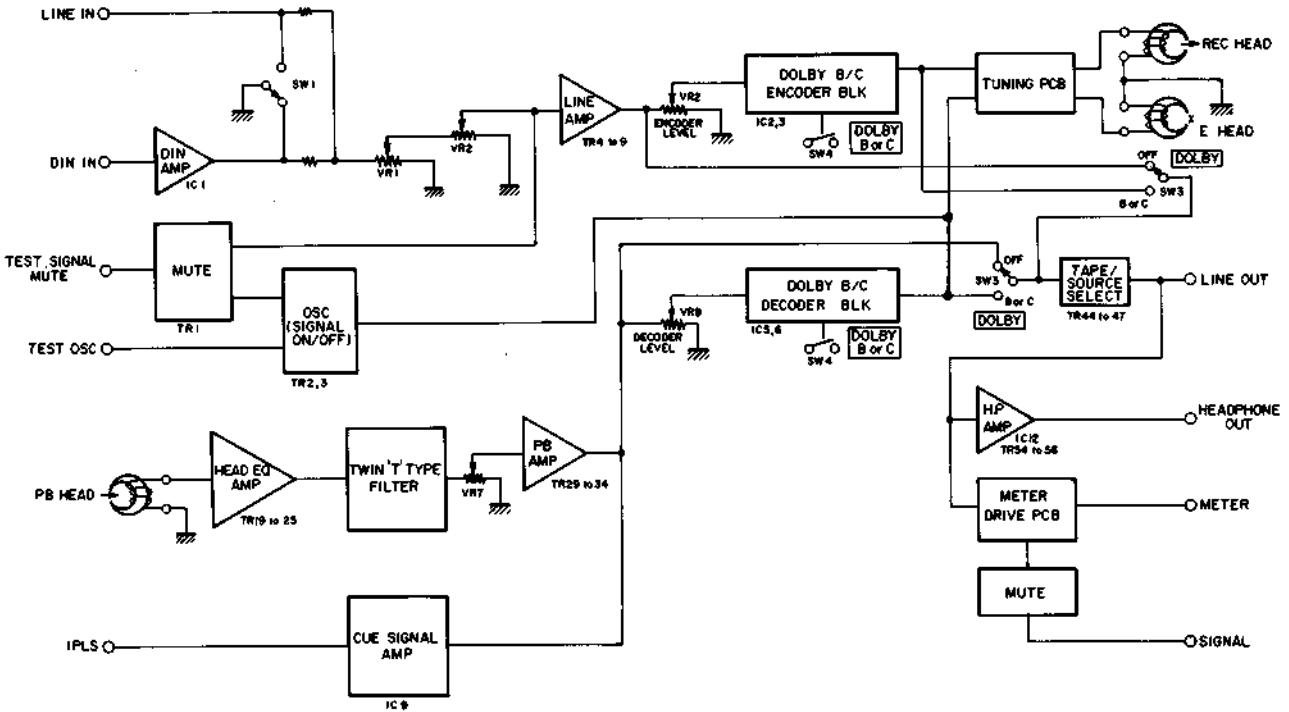

Fig. 1-16

2. PB HEAD EQ AMP (Fig. 1-17)

The PB signal from the PB head is amplified by AMP 1 (differential amp) and then make negative feed back through R103, R104, R106 and R95. The amplified signal is subjected to DC balancing with VR4 (100B) of AMP 1. The DC balance of the entire AMP 1 is once again set up by VR6 on the "source" side of TR25.

Subsequently, the signal is routed to VR7 via a filter (R110, R111, R112, C52, C53, and C54). (With CrO₂ or METAL, TR27 is activated and the PB high-range EQ curve is changed to a 70 msec time constant with C55, R113 and R114.)

The signal is then adjusted by VR7 (PB LEVEL) before being sent to LINE OUT via AMP 2 (with Dolby IC or Dolby OFF). R134 and R126 of AMP2 provide NF.

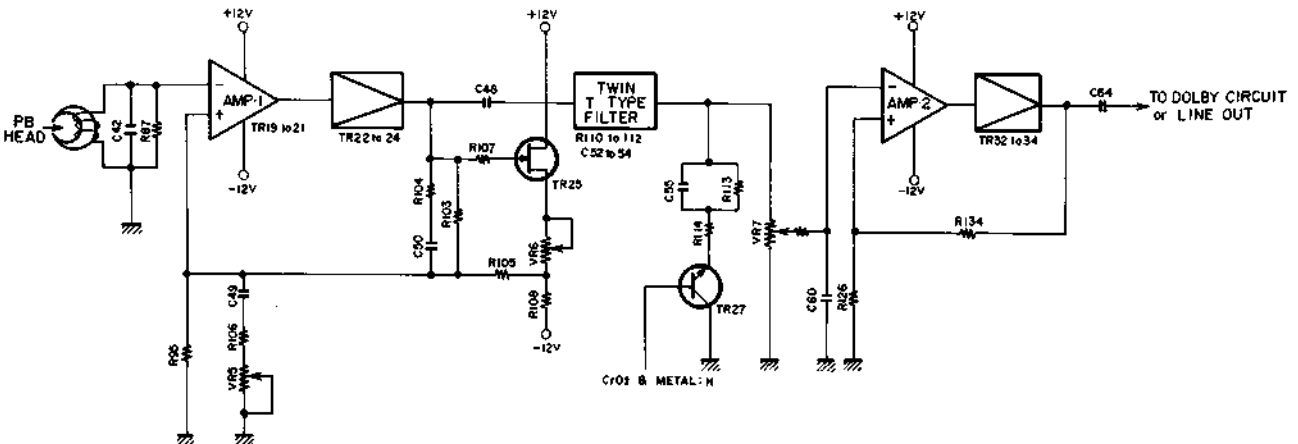
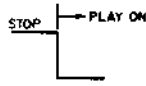

Fig. 1-17

3. TAPE/SOURCE MONITOR SWITCHING AND MUTE CIRCUITS (Refer to Fig. 1-18)

PB MUTE terminal :

L' (PLAY only), H' (others),



causes TR2 OFF and TR1 OFF.

S (H) terminal "L", Pre amp, TR45 OFF, TR44 ON and PB ON.

PLAY terminal :



Signal (as determined by com-

combined time constants of R58 and C13) activates TR15 and ⑥ of IC1 is set to "L".

Because of IC1 [NAND], ④ of IC1 → "H" and ③ of IC1 → "L".

Thus, TR17 OFF, and TR16 ON.

L' to SOURCE IND, and H' to TAPE IND.

Rec/PLAY terminal :

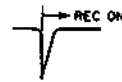

TR13 OFF, TR14 ON, ① of

IC1 → L', ③ of IC1 → H, TAPE IND → L, and SOURCE IND → H'.

Power ON MUTE :

TR3 ON { ⑨ of IC5 → H' and ⑩ → L' and then TAPE MONITOR comes on. MUTE on pre amp side via D33, D2 and D1, resulting in both TAPE and SOURCE being muted.

Power OFF MUTE :

At power OFF time, TR4 is activated by charging current (C2); MUTE on pre amp side via D1 and D2.

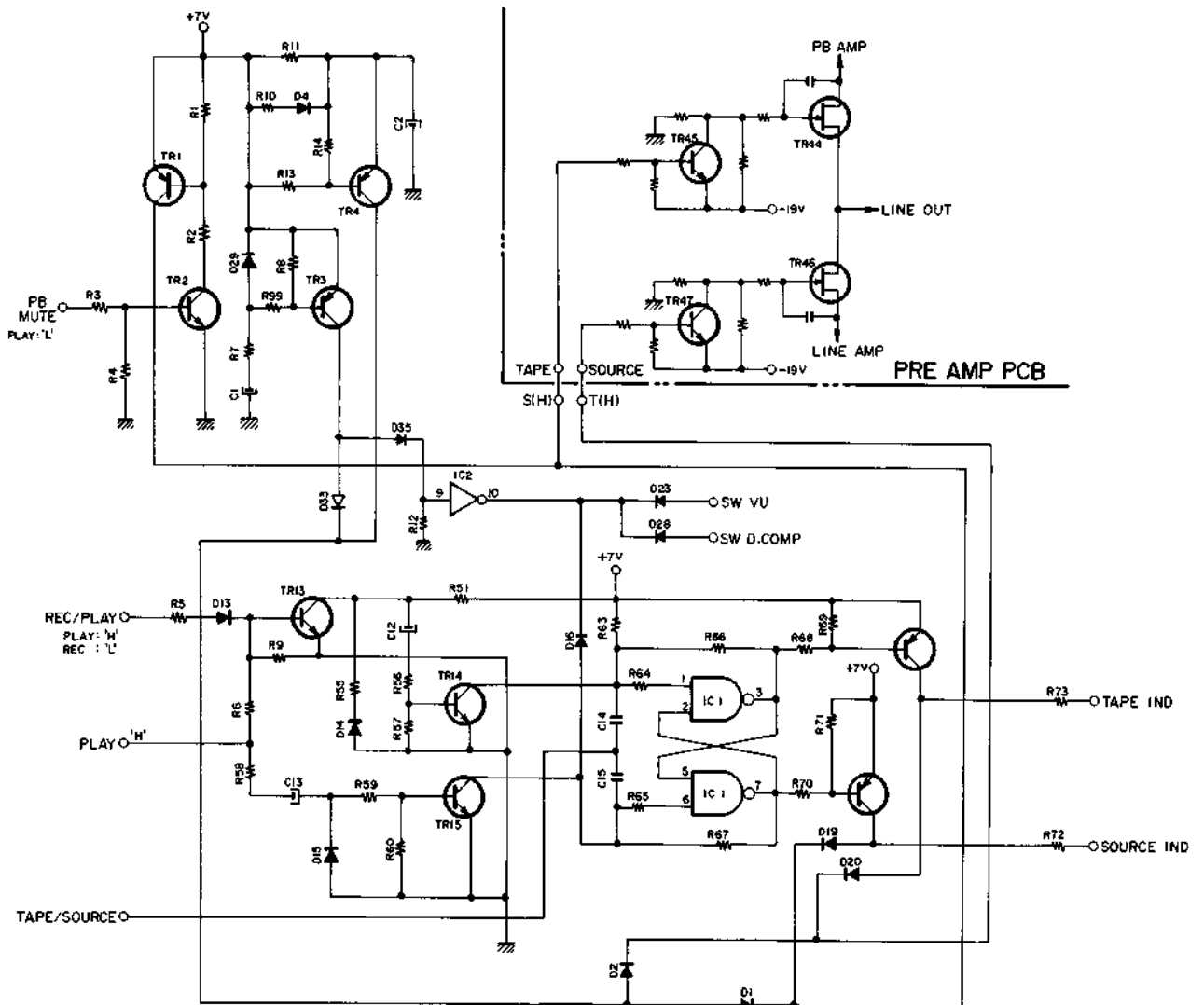

Fig. 1-18

SECTION 2

SERVICE MANUAL

TABLE OF CONTENTS

I. SPECIFICATIONS	24
II. DISMANTLING OF UNIT	25
III. CONTROLS	26
IV. PRINCIPAL PARTS LOCATION	28
V. VOLTAGE CONVERSION AND CYCLE CONVERSION	30
VI. MECHANICAL ADJUSTMENT	31
VII. HEAD ADJUSTMENT	34
VIII. PRE AMP PCB ADJUSTMENT	36
IX. TUNING PCB ADJUSTMENT	38
X. METER DRIVE PCB ADJUSTMENT	40
XI. DC RESISTANCE OF HEADS	41
XII. CLASSIFICATION OF VARIOUS P.C BOARDS	41
1. P.C BOARD TITLES AND IDENTIFICATION NUMBERS	41
2. COMPOSITION OF VARIOUS P.C BOARDS	42

For basic adjustments, measuring methods, and operating principles, refer to GENERAL TECHNICAL MANUAL.

I. SPECIFICATIONS

TRACK SYSTEM	4 Track 2 Channel Stereo System
TAPE	Philips Type Cassette
TAPE SPEED	4.76 cm/s \pm 1.0% (1-7/8 ips. \pm 1.0%)
HEADS	Super GX head for Recording \times 1 Super GX head for Playback \times 1 Erase head \times 1
MOTORS	Quartz Locked PLL servo DC motor for direct capstan drive \times 1 DC motor for reel drive \times 1
WOW & FLUTTER	0.07% WTD (DIN) 0.025% WRMS
TAPE WINDING TIME	90 sec. using a C-60 cassette tape
FREQUENCY RESPONSE	Normal: 20 to 18,000 Hz \pm 3 dB (-20 VU) CrO ₂ : 20 to 19,000 Hz \pm 3 dB (-20 VU) Metal: 20 to 21,000 Hz \pm 3 dB (-20 VU)
SIGNAL TO NOISE RATIO	Metal: Better than 60 dB (measured via tape with peak recording level) Dolby B-type NR switch ON: Improves up to 5 dB at 1 kHz, 10 dB above 5 kHz Dolby C-type NR switch ON: Improves up to 15 dB at 500 Hz, 20 dB at 1 kHz to 10 kHz
HARMONIC DISTORTION	1 kHz, 3rd harmonic distortion Metal: Less than 0.8%
INPUT	Line: 70 mV (input impedance: 47 kohms)
OUTPUT	Line: 410 mV at 0 VU Required load impedance: more than 20 kohms Phone: 1.3 mW/8 ohms at 0 VU
DIN	Input: 2.0 mV (input impedance: 10 kohms) Output: 410 mV Required load impedance: more than 20 kohms
POWER REQUIREMENTS	100V, 50/60 Hz for Japan 120V, 60 Hz for USA and Canada 220V, 50 Hz for Europe except UK 240V, 50 Hz for UK and Australia 110V/120V/220V/240V, 50/60 Hz switchable for other countries
POWER CONSUMPTION	39W
DIMENSIONS	440 (W) \times 100 (H) \times 363 (D) mm (17.3 \times 3.9 \times 14.3")
WEIGHT	9.8 kg (21.6 lbs)

* For improvement purposes, specifications and design are subject to change without notice.

* "Dolby" and the Double D symbol are trademarks of Dolby Laboratories Licensing Corporation.

(Manufactured under license from Dolby Laboratories Licensing Corporation.)

II. DISMANTLING OF UNIT

In case of trouble, etc. necessitating dismantling, please dismantle in the order shown in the photographs. Reassemble in reverse order.

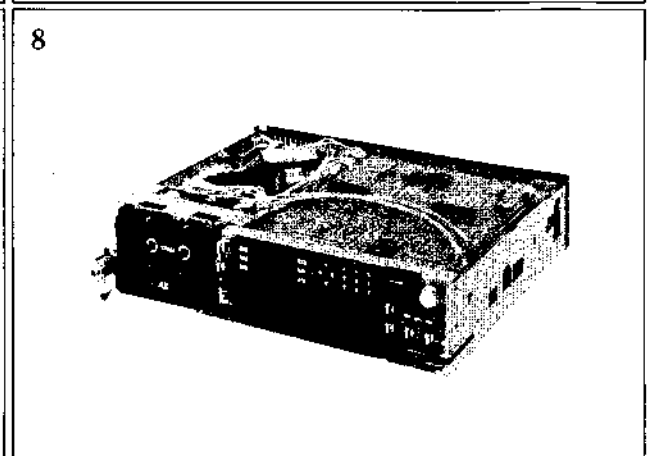
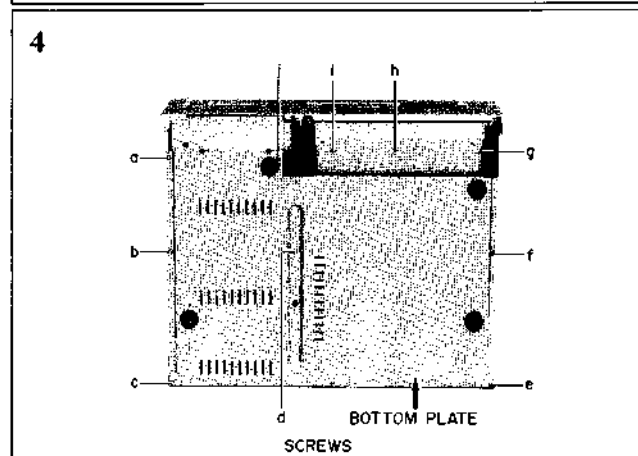
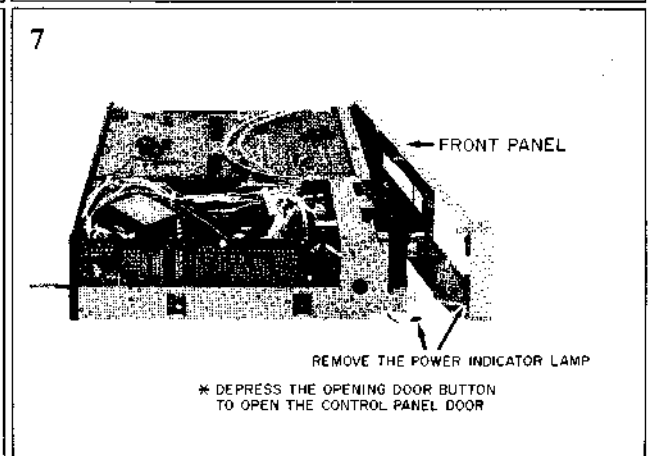
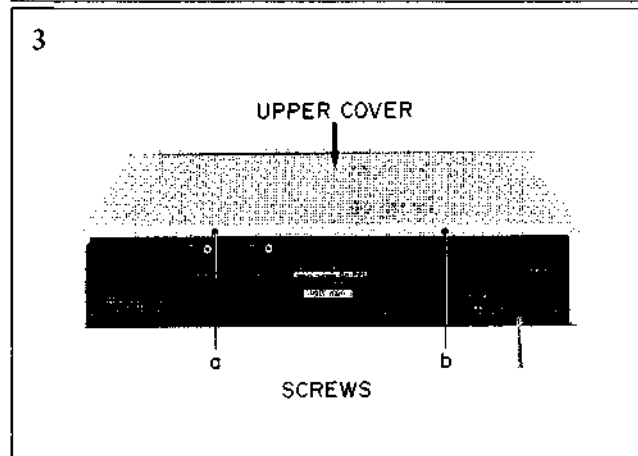
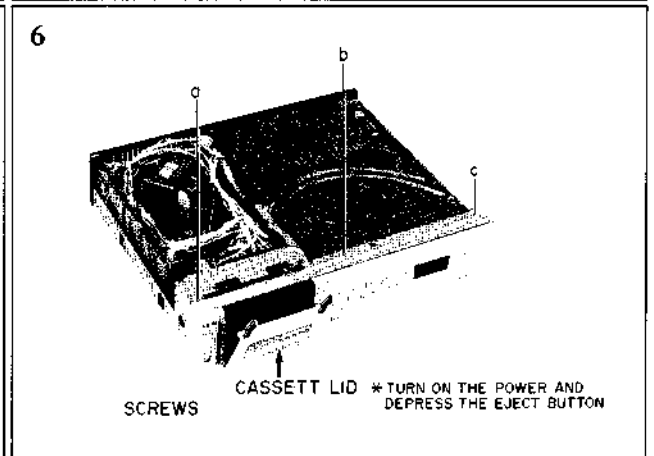
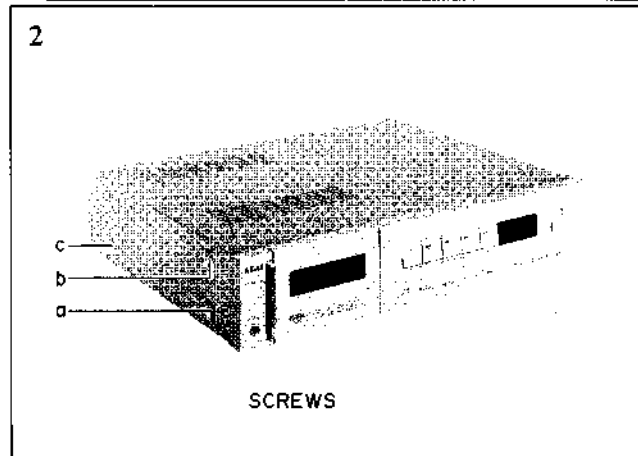
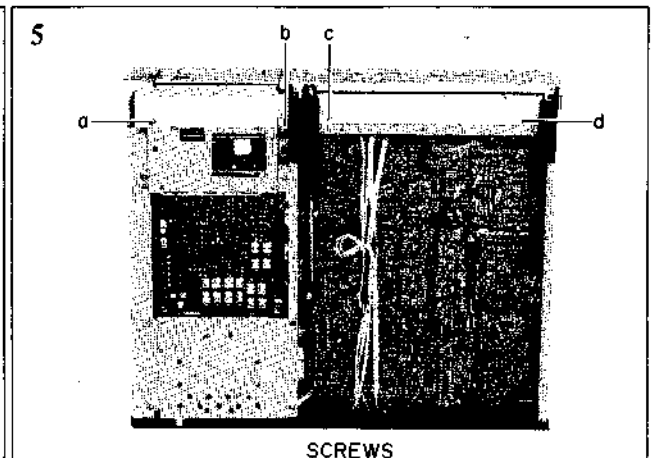
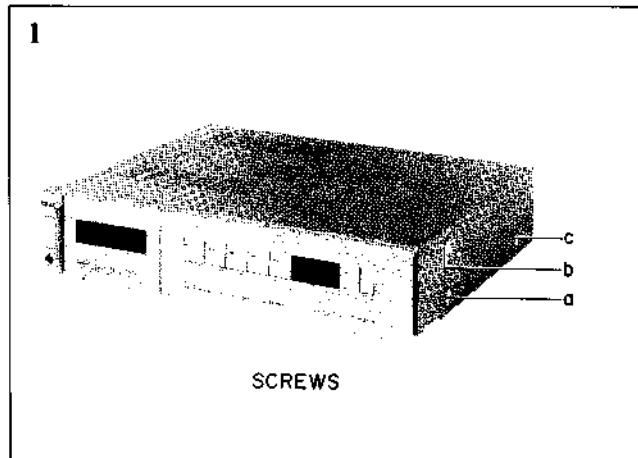

III. CONTROLS

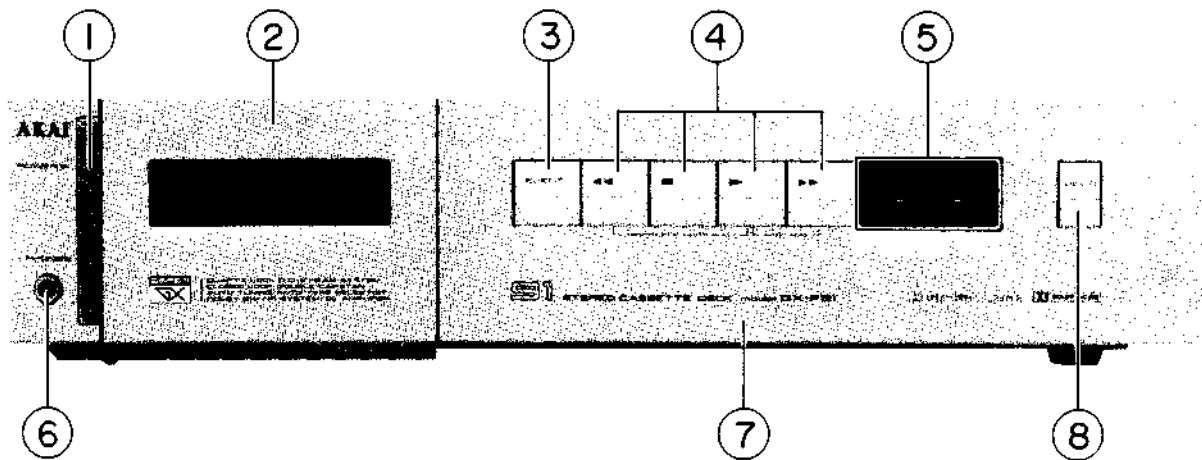

Fig. 2-1

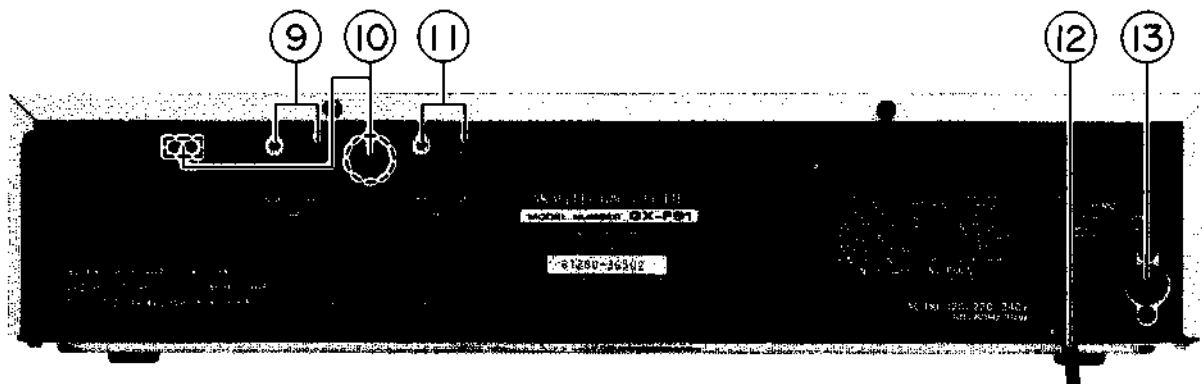

Fig. 2-2

- | | |
|--|---|
| <ul style="list-style-type: none"> 1. POWER SWITCH 2. CASSETTE RECEPTACLE 3. EJECT BUTTON 4. OPERATING BUTTONS with INDICATORS 5. DOLBY NR B-TYPE and C-TYPE INDICATORS 6. HEADPHONE (PHONES) JACK 7. CONTROL PANEL DOOR 8. OPENING DOOR BUTTON 9. LINE IN JACKS 10. LINE/DIN SELECTOR and DIN JACK
(Some models are not equipped with these facilities.) 11. LINE OUT JACKS 12. POWER CORD 13. REMOTE JACK 14. TIMER START SELECTOR | <ul style="list-style-type: none"> 15. AUTO SYSTEM SELECTOR 16. AUTO MONITOR SELECTOR with INDICATOR 17. RECORDING (REC) LEVEL CONTROL 18. CONTROL PANEL DOOR 19. EJECT BUTTON 20. OPERATING BUTTONS and INDICATORS 21. AUTO MUTE BUTTON 22. RECORDING (REC) CANCEL BUTTON 23. AUTO FADER BUTTON 24. CLOSING DOOR BUTTON 25. HEADPHONE (PHONES) CONTROL (MIN/MAX) 26. OUTPUT CONTROL (MIN/MAX) 27. RECORDING (REC) BALANCE CONTROL
(L: left, R: right) |
|--|---|

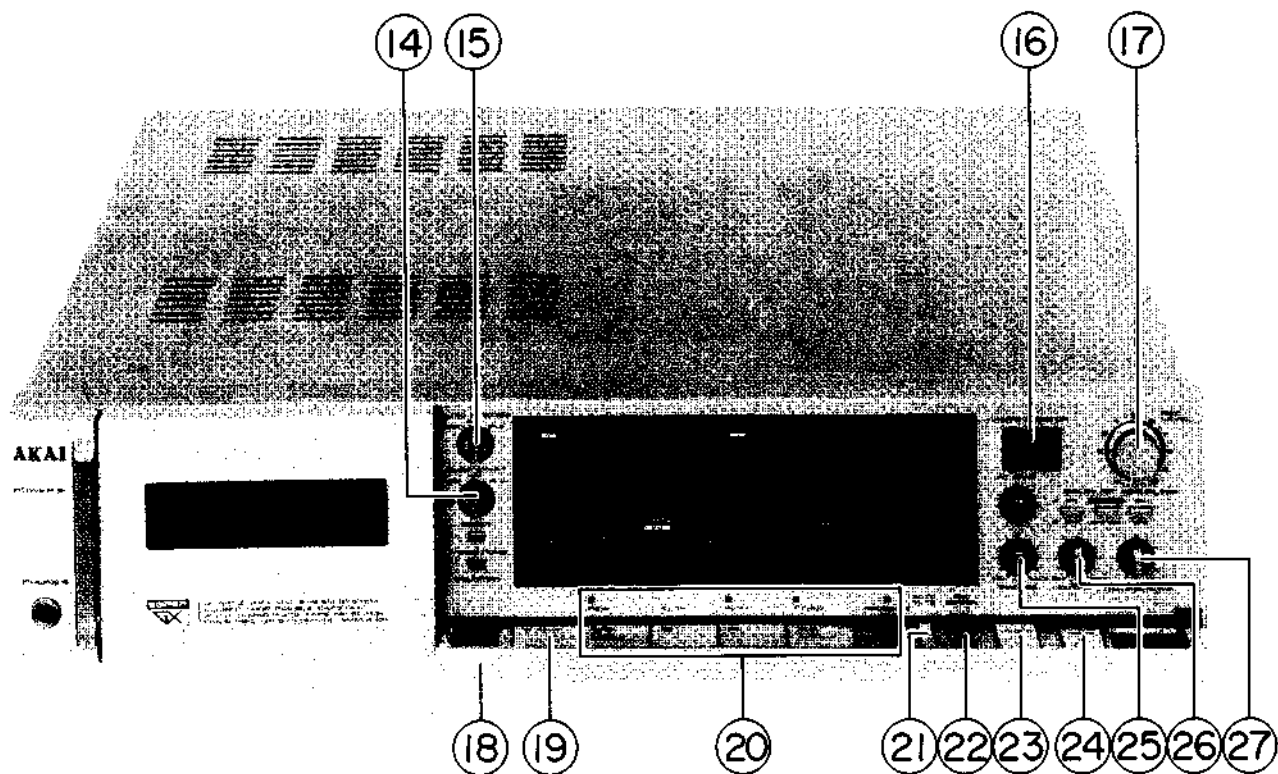

Fig. 2-3

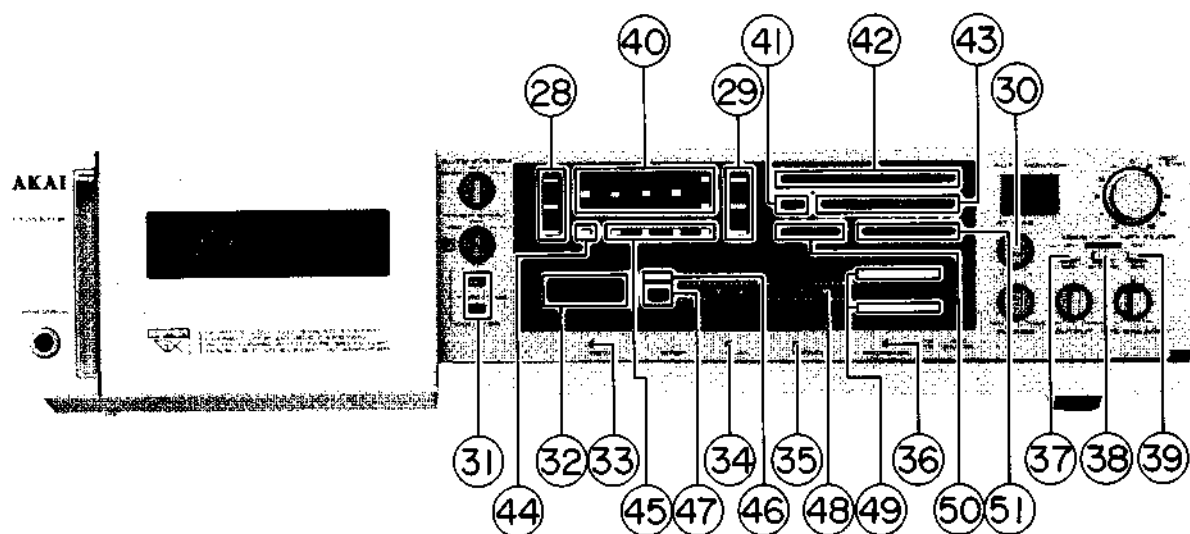

Fig. 2-4

- | | |
|--|--|
| 28. TAPE POSITION INDICATORS | 40. AUTO TAPE TUNING INDICATORS |
| 29. DOLBY NR B-TYPE and C-TYPE FILTER INDICATORS | 41. REFERENCE (REF) BUTTON |
| 30. AUTO TUNING (AT) BIAS CONTROL | 42. AUTO TAPE TUNING CONTROL BUTTONS |
| 31. RESET BUTTON and TAPE/TIME SELECTOR | 43. MEMORY BUTTONS (M1 to M4) |
| 32. FL DIGITAL DISPLAY | 44. REFERENCE (REF) INDICATOR |
| 33. REWIND (◀ REW) INDICATOR | 45. MEMORY INDICATORS (M1 to M4) |
| 34. ▶ PLAY INDICATOR | 46. D.COMP INDICATOR |
| 35. FAST FORWARD (▶▶ F.FWD) INDICATOR | 47. METER INDICATORS |
| 36. REC/PAUSE INDICATOR | 48. FL DIGITAL BAR METER |
| 37. DOLBY NR SWITCH | 49. MAXIMUM INPUT LEVEL (MIL) INDICATORS |
| 38. DOLBY NR SELECTOR | 50. D.COMP (Dynamic Range Compensation) BUTTON |
| 39. MPX FILTER SWITCH | 51. METER SELECTORS |

IV. PRINCIPAL PARTS LOCATION

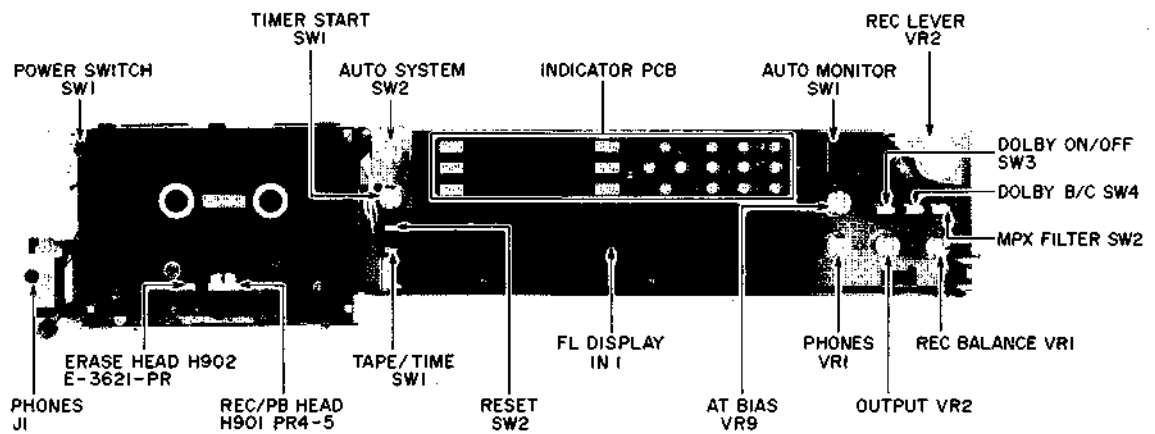

Fig. 2-5 Front View

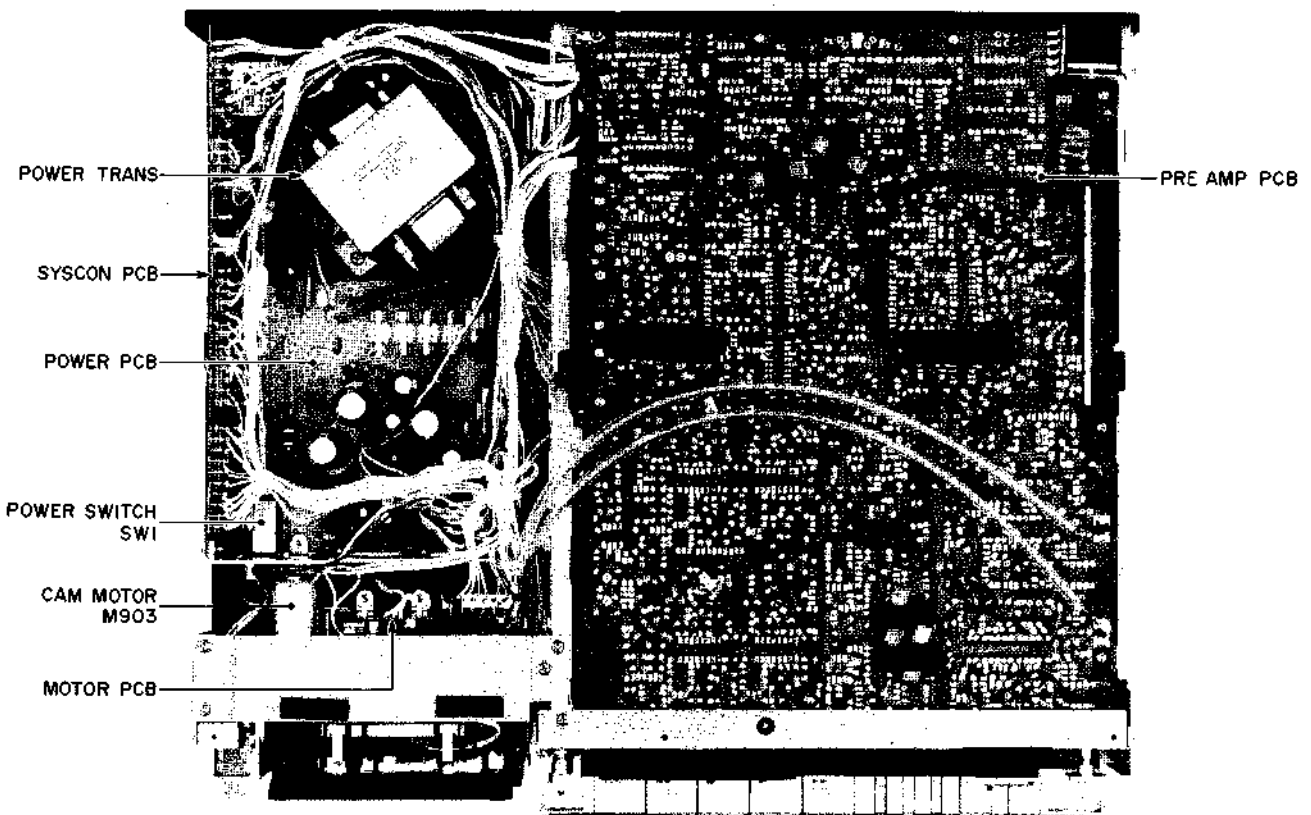

Fig. 2-6 Top View

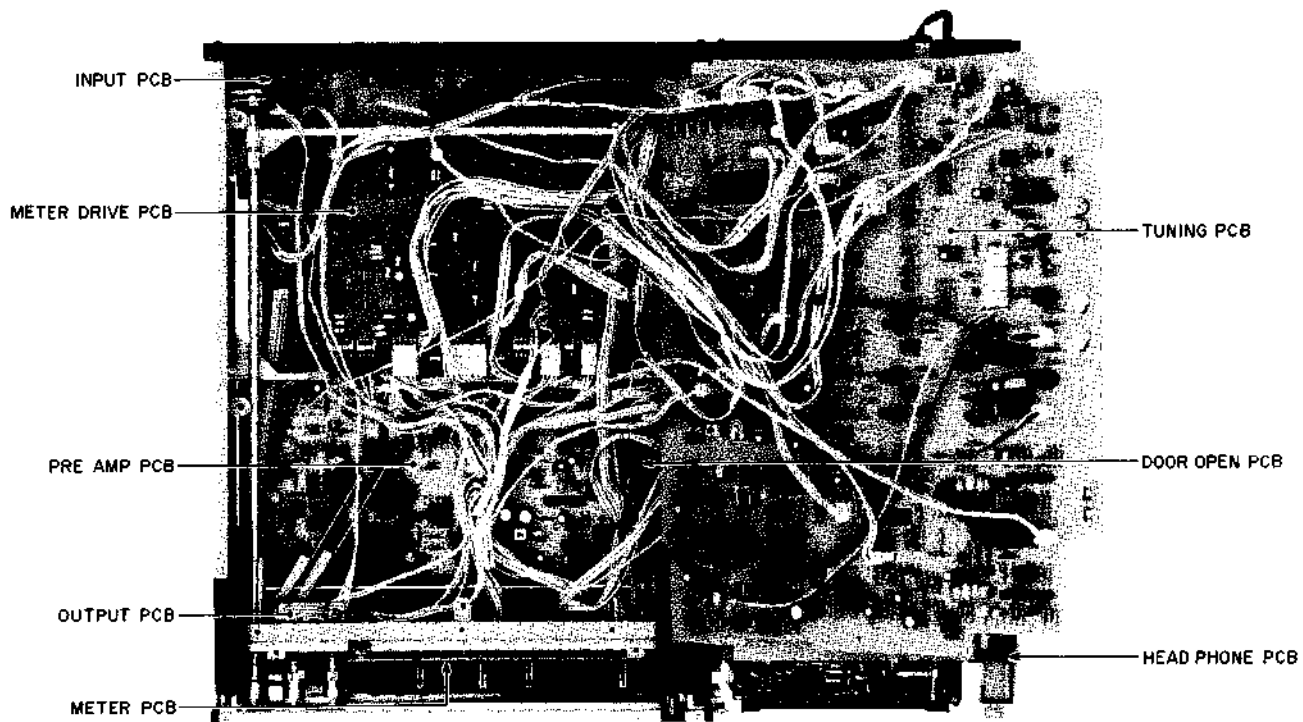

Fig. 2-7 Bottom View

V. VOLTAGE CONVERSION AND CYCLE CONVERSION

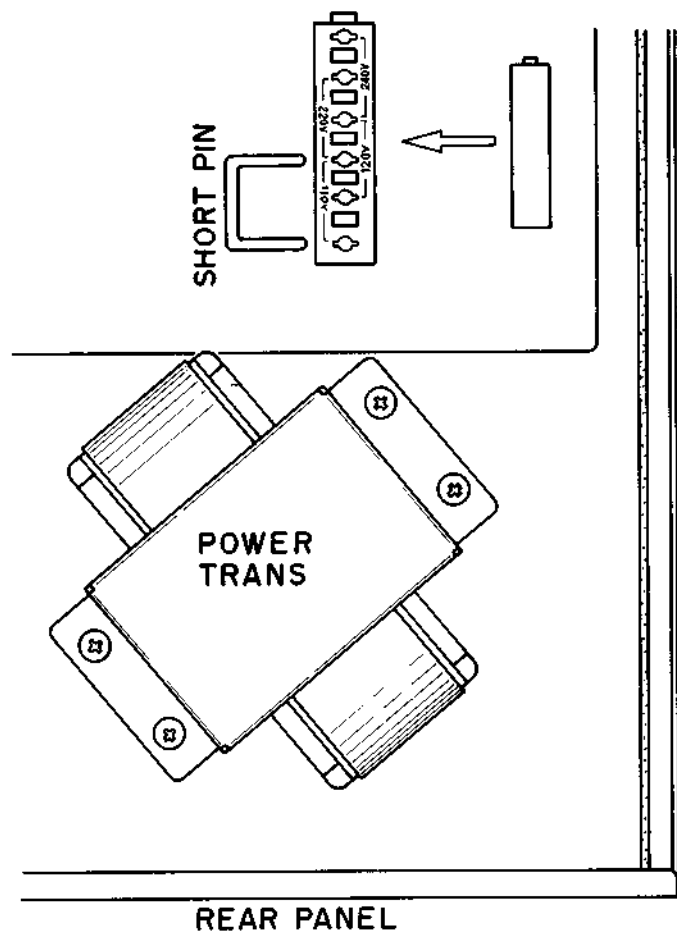

Fig. 2-8 Voltage Conversion (U Model)

1. VOLTAGE CONVERSION

Models for Canada, Europe, USA, UK, Australia and Japan are not equipped with this facility.

Each machine is preset at the factory according to destination, but some machines can be set to 110V, 120V, 220V or 240V as required.

If voltage change is necessary, this can be accomplished as follows:

- 1) Disconnect power cord.
- 2) Loosen holding screws and remove upper cover.
- 3) Remove short pin plug from present holes and replace in correct holes. Follow the markings explicitly.

2. CYCLE CONVERSION

With DC motor, cycle conversion is not necessary.

VI. MECHANICAL ADJUSTMENT

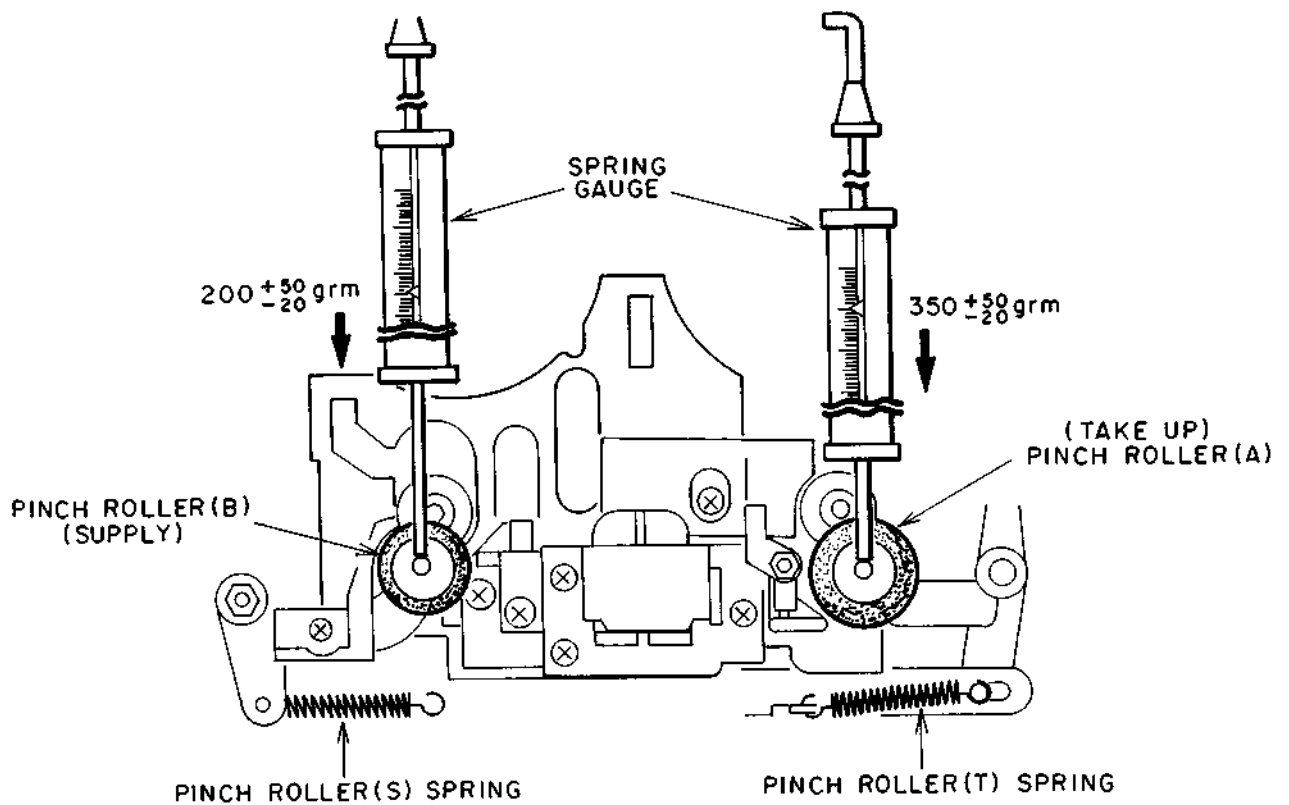

Fig. 2-9

1. PINCH ROLLER PRESSURE MEASUREMENT (Refer to Fig. 2-9)

Put in PLAY mode. Push pinch roller arm down with the spring gauge push the pinch roller 1 ~ 2 mm from the capstan and release slowly. Read the spring gauge at the moment the pinch roller touches the capstan and begins to rotate.

Specified pressure: 350^{+50}_{-20} gm (Take up)

200^{+50}_{-20} gm (Supply)

If there is no measurement obtained, replace the pinch roller spring.

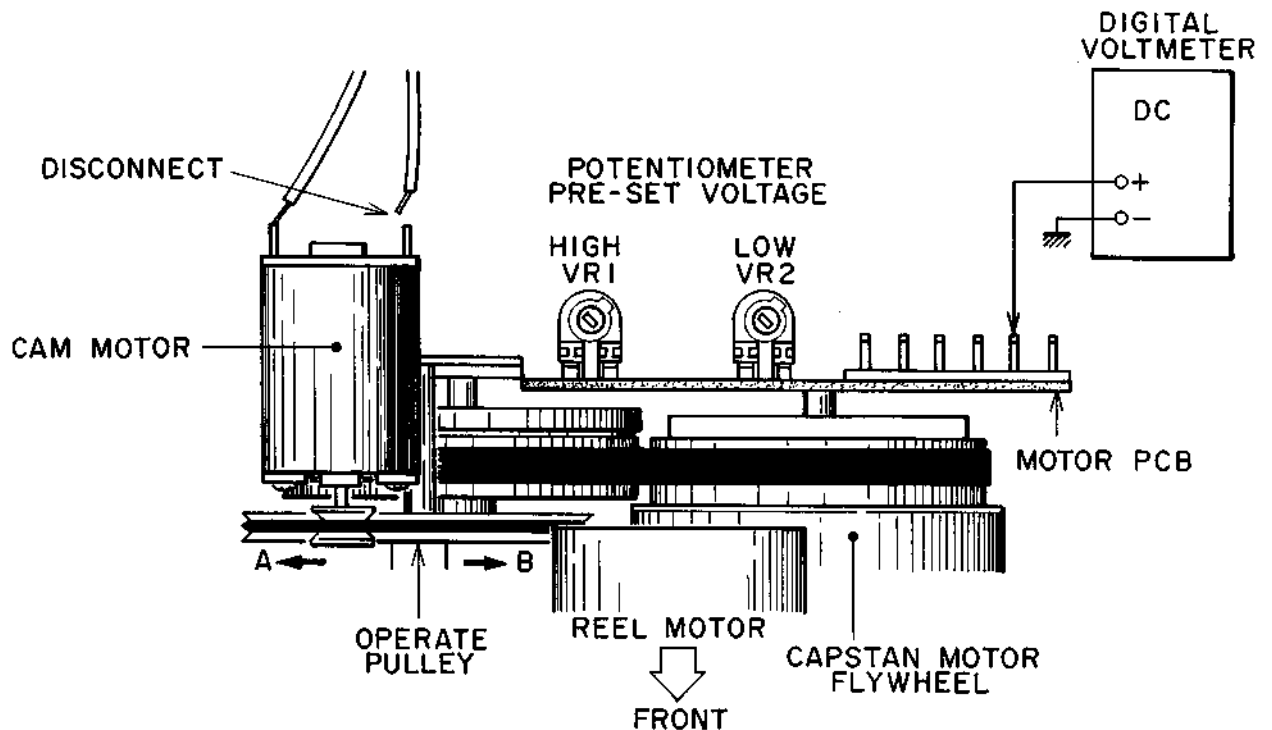

Fig. 2-11

3. POTENTIOMETER PRESET VOLTAGE ADJUSTMENT (Refer to Fig. 2-11, 12)

1) LOW VOLTAGE ADJUSTMENT

- a. With power OFF, remove the connecting cord of the cam motor and turn the operate pulley fully with your fingers in A direction.
- b. Connect the digital voltmeter as shown in Fig. 2-11.
- c. With power ON, adjust VR2 so that the voltage reading will be 0.78V (DC).

2) HIGH VOLTAGE ADJUSTMENT

- a. With power OFF, turn the operate pulley fully with your fingers in B direction.
- b. With power ON, adjust VR1 so that the voltage reading will be 6.73V (DC).

3) Repeat Items 1) and 2).

- 4) a. With Power OFF, connect the connecting cord of the motor.
- b. Remove the digital voltmeter.

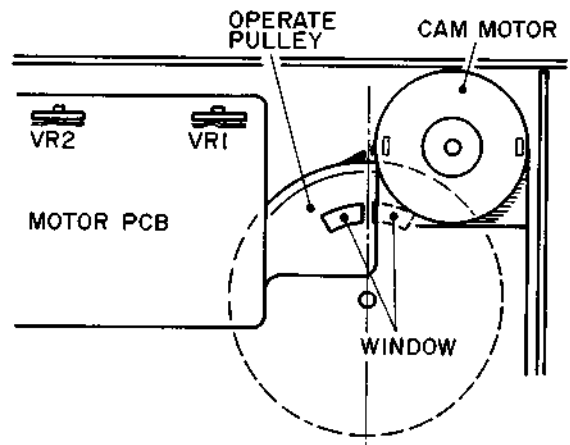

Fig. 2-12 Position of Operate Pulley in STOP Mode

- 5) a. Set power to ON.
- b. Adjust VR1 slightly so that a center line between windows of the operate pulley will face directly above during STOP Mode. (Fig. 2-12)
- c. Remove the cassette lid and set the AUTO SYSTEM switch to IPLS Mode.
- d. Confirm that the head and pinch roller do not move up and down when the FF and REW switches are alternately depressed.
- e. Turn the reel with fingers in TOP Mode to check that the brake works sufficiently. When the brake acts normally, the take-up reel does not turn clockwise while the supply reel does not rotate counterclockwise.

VII. HEAD ADJUSTMENT

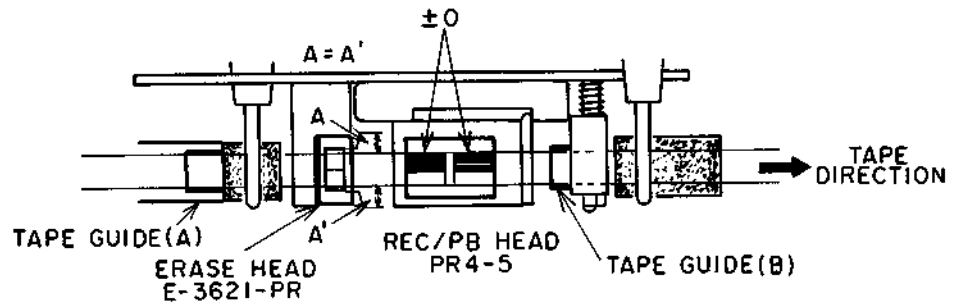
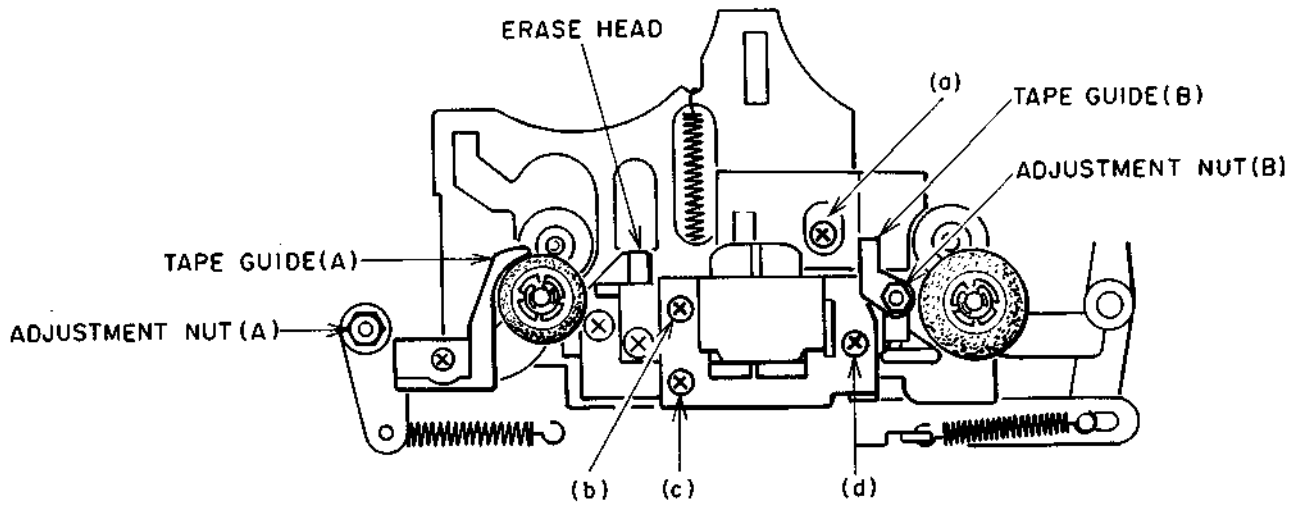

Fig. 2-13

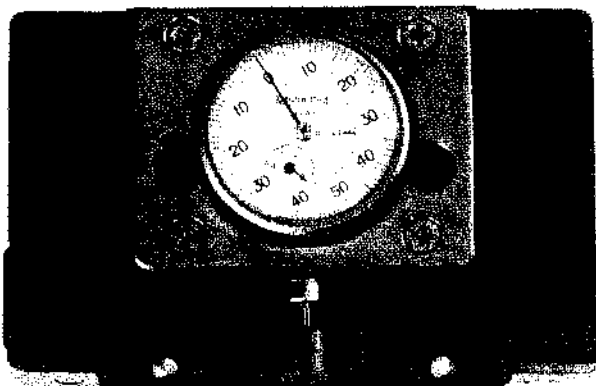

Fig. 2-14 Cassette Head Projection Gauge (TF-111CJ)



Fig. 2-15 Mirror Cassette Tape (TF-109CM)

1. REC/PB HEAD PROJECTION ADJUSTMENT

Set the cassette head projection gauge (TF-111CJ) and set to PLAY mode. Loosen the screw (a) and adjust so that the gauge indication at that time will be 3.2 ± 0.05 mm. After adjustment, apply paintlock on the screw (a).

2. TAPE GUIDE HEIGHT ADJUSTMENT

- 1) Set the mirror cassette tape (TF-109CM) and set to PLAY mode.
- 2) Adjust the tape guide (A) so that the parts of the erase head coming out of both sides of the tape (A and A' in Fig. 2-13) will be equal. For the adjustment, use the adjustment nut (A).
- 3) Adjust the tape guide (B) so that the tape runs smoothly and is not hitched by the tape guide. For the adjustment, use the adjustment nut (B).
- 4) After adjustment, paint-lock the adjustment nuts (A) and (B).

3. REC/PB HEAD HEIGHT ADJUSTMENT

- 1) Set the mirror cassette tape and set to PLAY mode.
- 2) Adjust the screws (b), (c) and (d) so that the upper edge of REC/PB head Lch core and the upper side of the tape is in alignment.
- 3) Playback the head height adjustment tape (4Tr 1,000 Hz) (TF-103CF), and fine-adjust the screws (b), (c) and (d) so that the largest output is obtained for both channels.

4. REC/PB HEAD AZIMUTH ALIGNMENT ADJUSTMENT

- 1) Playback a 10 kHz Head Azimuth Alignment Tape (TF-106CH) and adjust the screw (d) until the output levels of both channels are at maximum.
- 2) Record a 10 kHz, -20VU signal from the audio frequency oscillator.
- 3) Rewind and check for any fluctuation in the output level at playback.
- 4) After adjustment, paintlock the screws (b), (c) and (d).

NOTES:

1. Be sure to clean the heads prior to head adjustment.
2. Be careful not to use a magnetized driver or other magnetized tools in the vicinity of the heads.
3. Be sure to demagnetize the heads with a Head Demagnetizer before and after head adjustment.

VIII. PRE AMP PCB ADJUSTMENT

- NOTES: 1. The parts with the mark * can be adjusted on the opposite (pattern) side, too.
 2.  indicates the level increasing direction.

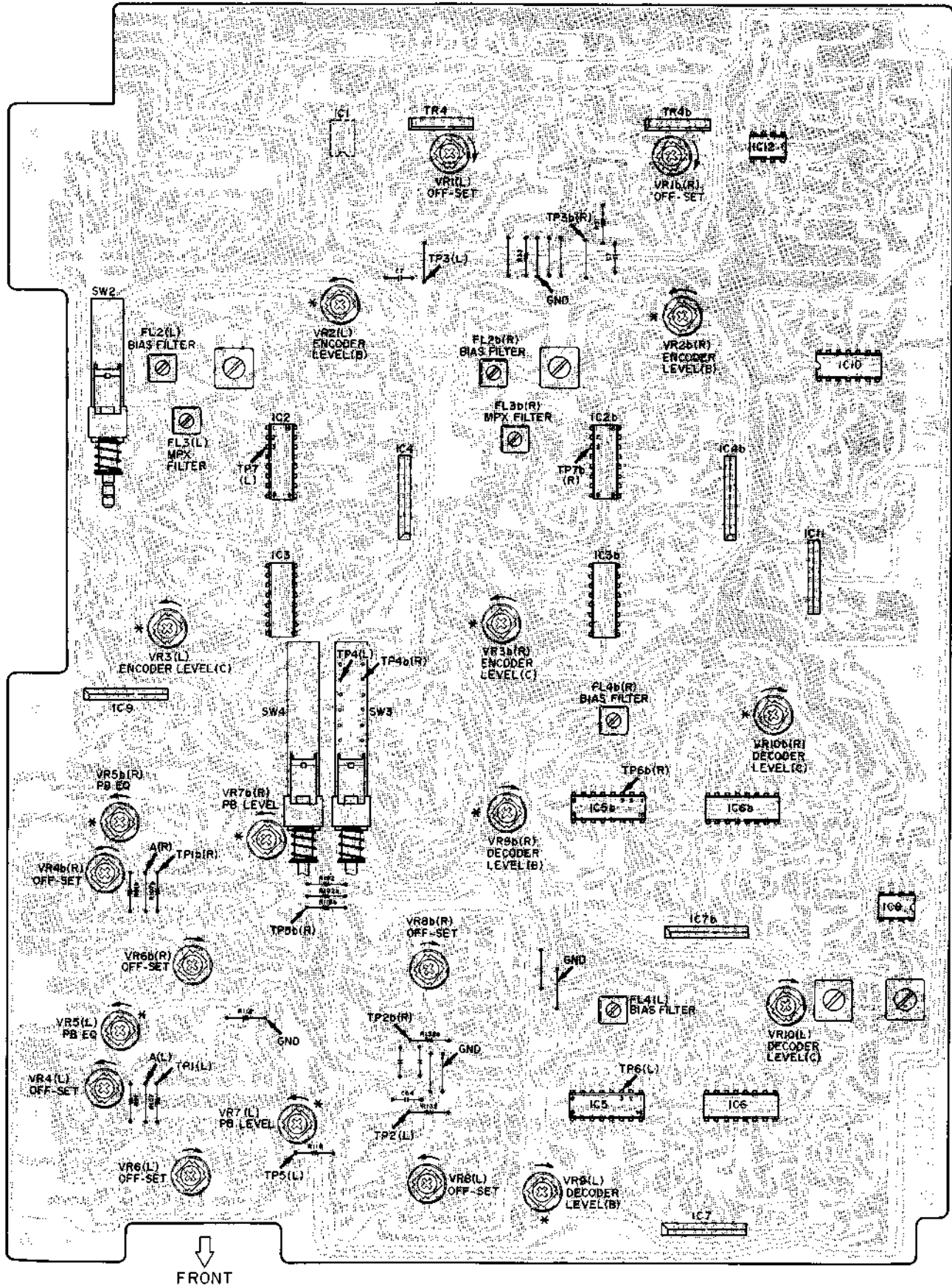

Fig. 2-16 Pre Amp PCB (Parts Side View)

1. PB DIFFERENTIAL AMPLIFIER OFF-SET VOLTAGE ADJUSTMENT (Fig. 2-16)

1) PB EQ AMP

- Connect point A to GND.
- Adjust VR4 so that the voltage to GND of TP1 will be 0 ± 500 mV DC.
- Remove the connecting cord of the point A.
- Adjust VR6 so that the voltage to GND of TP1 will be 0 ± 10 mV DC.

2) PB LINE AMP

- Adjust VR8 so that the voltage to GND of TP2 will be 0 ± 10 mV DC.

3) REC LINE AMP

- Adjust VR1 so that the voltage to GND of TP3 will be 0 ± 10 mV DC.

2. PB EQ AMP ADJUSTMENT (Fig. 2-16)

1) PB LEVEL

Play back 333 Hz PB level adjustment tape (TF-101CL) and adjust VR7 so that the LINE OUT level will be -5.5 ± 0.2 dBm.

2) PB EQ

Play back 10 kHz PB EQ adjustment tape (TF-106CH) and adjust VR5 so that the LINE OUT level will be -22.5 ± 1.5 dBm.

3. DOLBY ENCODER ADJUSTMENT

(Fig. 2-16)

1) ENCODER LEVEL

- With the monitor SW to SOURCE, input signal of 400 Hz into the LINE INPUT and adjust the input level so that the level of TP4 will be -2.5 ± 0.1 dBm (580 mV) when Dolby is OFF.
- Adjust VR2 so that the level of TP4 will be the same level as a. (-2.5 ± 0.1 dBm) when Dolby B-type is ON.
- Adjust VR3 so that the level of TP4 will be the same level as a. (-2.5 ± 0.1 dBm) when Dolby C-type is ON.

2) MPX Filter Adjustment

- With the monitor SW to SOURCE and MPX filter SW "OFF", input a signal of 19 kHz from LINE IN.
- Adjust FL3 so that the LINE OUT level will be at minimum when MPX filter SW is turned ON.

3) BIAS Filter Adjustment

- Input a signal of 100 kHz from LINE IN.
- Adjust FL2 so that the LINE OUT level will be at minimum.

4. DOLBY DECODER ADJUSTMENT

(Fig. 2-16)

1) DECODER Level Adjustment

- Set a S/N pack (NOTES: 3) and set to PLAY mode.
- Input the signal of 400 Hz into TP5 and adjust the input level so that the LINE OUT level will be -2.5 ± 0.1 dBm (580 mV) when Dolby is OFF.

(Audio oscillator is connect to TP5 and GND of the Pre Amp PCB).

- Adjust VR9 so that the LINE OUT level will be the same level as a. (-2.5 ± 0.1 dBm) when Dolby B-type is ON.
- Adjust VR10 so that the LINE OUT level will be the same level as a. (-2.5 ± 0.1 dBm) when Dolby C-type is ON.

2) BIAS Filter Adjustment

- Set a S/N pack (NOTES: 3) and set to PLAY mode.
- Input the signal of 100 kHz into TP5.
(Audio Oscillator is connect to TP5 and GND of the Pre Amp PCB).
- Adjust FL4 so that the level of IC5 ③ will be at minimum.

NOTES:

- A digital voltmeter should be used for the measurement of DC voltage and an AC voltmeter (mV meter) for the measurement of AC voltage, and the input impedance should be 10 Mohms or more.
- Output level control should be at maximum.
- The S/N pack allows only the pad to contact the head with a cassette tape cut or removed, and is used so the head will not pick up noise.

IX. TUNING PCB ADJUSTMENT

- NOTES: 1. The parts with the mark * can be adjusted on the opposite (pattern) side, too.
 2.  indicates the level increasing direction.

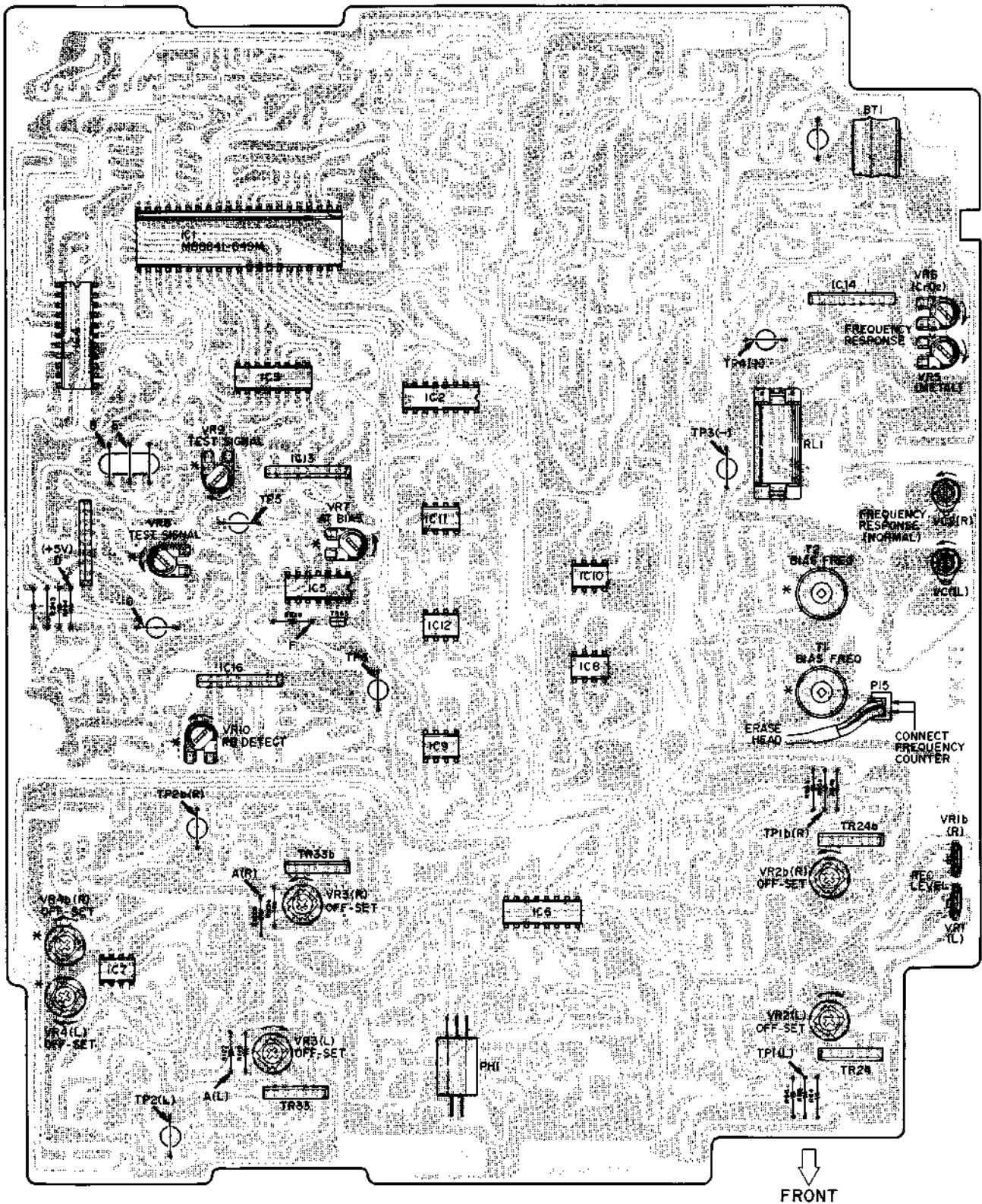

Fig. 2-17 Tuning PCB (Parts Side View)

1. REC DIFFERENTIAL AMPLIFIER OFF-SET VOLTAGE ADJUSTMENT

(Fig. 2-17)

- 1) Adjust VR2 so that the voltage to GND of TP1 will be 0 ± 10 mV DC.
- 2) Connect point A to GND.
- 3) Adjust VR3 so that the voltage to GND of TP2 will be 0 ± 500 mV DC.
- 4) Remove the connecting cord of the point A.
- 5) Adjust VR4 so that the voltage to GND of TP2 will be 0 ± 2 mV DC.
(Be careful to make this adjustment, otherwise DC current will through the REC Head).

2. REC BIAS OSC ADJUSTMENT (Fig. 2-17)

- 1) Set a metal tape and set to REC/PLAY mode.
- 2) Set VC1 and VC2 as shown in Fig. 2-17.
- 3) Connect the frequency counter to P15 (Tuning PCB) and adjust T1 so that the frequency will be 100 ± 0.2 kHz.
- 4) Connect a DC voltmeter between TP3 (-) and TP4 (+) and adjust T2 so that the voltage will be at minimum. (Less than 50 mV DC)

3. FREQUENCY RESPONSE ADJUSTMENT

(Fig. 2-17)

- 1) Record and play back 1 kHz/10 kHz, -25.5 dBm using a normal tape and adjust VC1 (L) and VC2 (R) so that 1 kHz/10 kHz will be 0 ± 0.5 dBm (provided L-R difference is within 0.5 dBm).
- 2) Record and play back 1 kHz/10 kHz, -25.5 dBm using a CrO₂ tape and adjust VR6 so that 1 kHz/10 kHz will be 0 ± 0.5 dBm.
- 3) Record and play back 1 kHz/10 kHz, -25.5 dBm using a metal tape and adjust VR5 so that 1 kHz/10 kHz will be 0 ± 0.5 dBm.

4. RECORDING LEVEL ADJUSTMENT

(Fig. 2-17)

Record and play back 1 kHz, -5.5 dBm using a normal tape, and adjust VR1 so that the difference between recording and playback levels will be 0 ± 0.3 dBm.

5. TEST SIGNAL ADJUSTMENT (Fig. 2-17)

- 1) Connect point B to GND.
- 2) Connect point C to point D (+5V).
- 3) Set to REC/PAUSE mode, adjust VR8 so that the LINE OUT level will be same level, when point E is connected to GND and when they are not connected.
- 4) Connect point E to GND and adjust VR9 so that the LINE OUT level will be -33.0 ± 0.2 dBm.

6. AT (ATUO TUNING) BIAS STANDARD VOLTAGE ADJUSTMENT (Fig. 2-17)

- 1) Set the AT BIAS volume to center (click position).
- 2) Adjust VR7 so that the voltage to GND of TP5 be 2.5 ± 0.2 V DC.

7. LEVEL ADJUSTMENT OF PLAYBACK OUTPUT LEVEL DETECTION CIRCUIT

(Figs. 2-16, 17)

(A/D Converter Analogue Level Adjustment)

- 1) Set a S/N pack (NOTES: 4) and set to PLAY mode.
- 2) Input a signal of 1 kHz into TP5 of Pre Amp PCB and adjust the input level so that the LINE OUT level will be -32.5 ± 0.2 dBm.
(Audio Oscillator is connect to TP5 and GND of the Pre Amp PCB).
- 3) Connect point F to GND.
- 4) Adjust VR10 so that the voltage to GND of TP6 will be 2.5 ± 0.05 V DC.

NOTES:

1. Using a digital voltmeter for the measurement of DC voltage and an AC voltmeter (mV meter) for AC voltage measurement, the input impedance should be 10 Mohms or more.
2. Output level control should be at maximum.
3. Use the following cassette measuring tapes:
Normal Tape : Maxell UD C-60
CrO₂ Tape : TDK SA C-60
Metal Tape : TDK MA C-60
4. The S/N pack allows only the pad to contact the head with a cassette tape cut or removed, and is used so the head will not pick up noise.

X. METER DRIVE PCB ADJUSTMENT

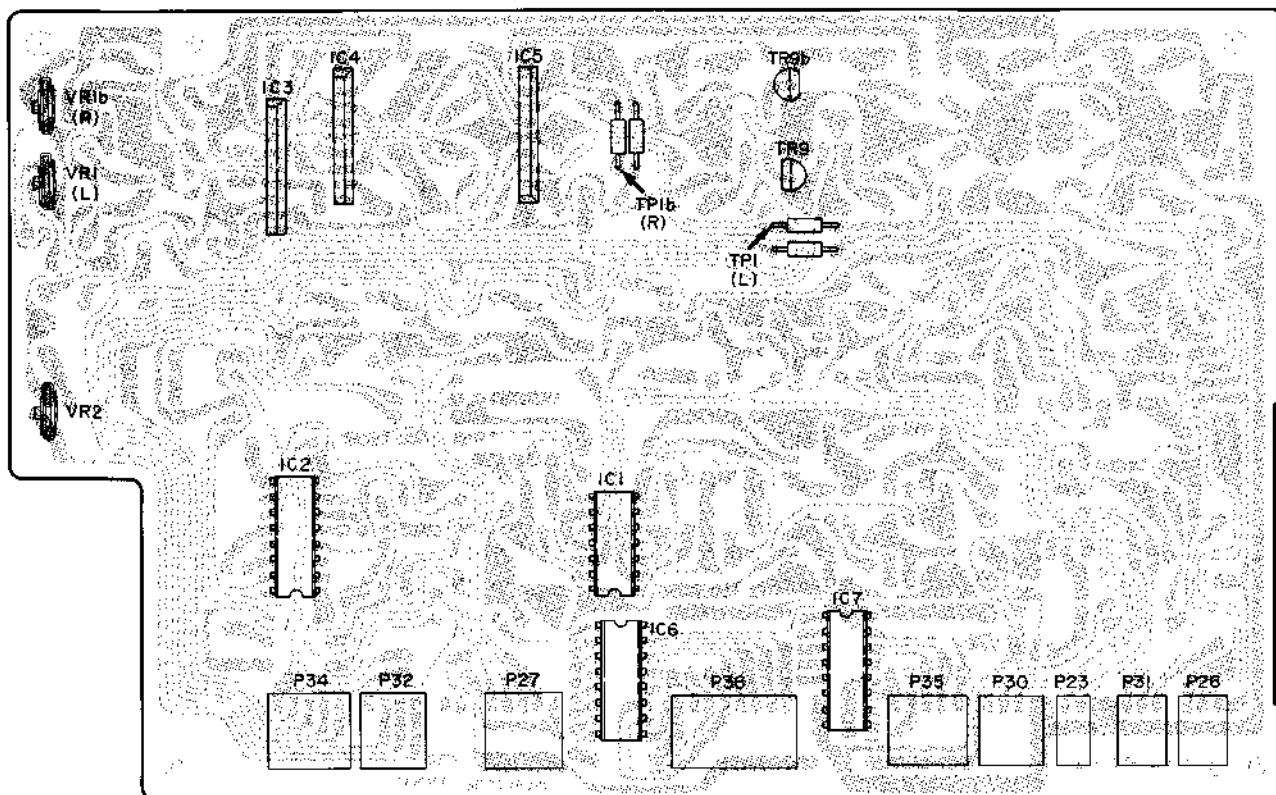

Fig. 2-18 Meter Drive PCB (Parts Side View)

1. METER ADJUSTMENT (Fig. 2-18)

1) VU Meters

- Set the meters to VU, and select the REC/PAUSE mode.
- Input a 1 kHz signal to LINE IN, and adjust the input level so that the LINE OUT level will be -5.5 dBm.
- Adjust VR1 to a ground voltage of $1.92 \sim 1.93$ V DC at TP1.
- Adjust VR2 so that the meter $+1$ dB is turned off when the LINE OUT level is reduced to -5.2 dBm.

2) PEAK I and PEAK II Operation Confirmation

- Take Steps 1) -a and 1) -b above.
- Check that the PEAK I and PEAK II meter readings are 0 ± 1 dB.

- Switch input on and off, and confirm that PEAK II does peak-hold, but that PEAK I does not peak-holds.

3) D. COMP Operation Confirmation

- Set the meters to VU, and select the REC/PAUSE mode.
- Input a 10 kHz signal so the meters read -10 dB.
- Confirm that, when the D-COMP button is depressed after loading a normal or CrO₂ tape, the meters read -2 ± 2 dB (difference between L and R less than 2 dB).
- Load a metal tape, and confirm that the meters read -3 ± 2 dB (difference between L and R less than 2 dB) in the D-COMP mode.

XI. DC RESISTANCE OF HEADS

Description	Name	DC Resistance
REC/PB Head	PR4-5	PB: 340 ohms \pm 10% REC: 320 ohms \pm 10%
Erase Head	E-3621-PR	2.5 ohms \pm 15%

XII. CLASSIFICATION OF VARIOUS P.C BOARDS

1. P.C BOARD TITLES AND IDENTIFICATION NUMBERS

P.C Board Title	P.C Board Number
Power P.C Board	T2033B5010
Indicator P.C Board	T2033C5020
Meter P.C Board	T2033B5030
Meter Drive P.C Board	T2033B5040
Operation P.C Board	T2033B5050
Syscon P.C Board	T2033B506A
Intermediate P.C Board	T2033B506B
Mode P.C Board	T2033B506C
Tuning P.C Board	T2033A5070
Pre Amp P.C Board	T2033A508A
Head Phone P.C Board	T2033A508B
LED P.C Board	T2033C5090
Door Open P.C Board	T2033C5100
Monitor P.C Board	T2033D5110
Counter Reset P.C Board	T2033D5120
Output P.C Board	T2033D5140
Input P.C Board	T2033D5150
REC PAUSE P.C Board	T2033D5160
Micro SW P.C Board	T2029D5020
Detector P.C Board	T2029D5030
Filter P.C Board	T2029D5040
FG P.C Board	M3103C7130
Motor P.C Board	M3103C726A
Potention P.C Board	M3103C726B

2. COMPOSITION OF VARIOUS P.C BOARDS

1) PRE AMP P.C BOARD T2033A508A (2ED)

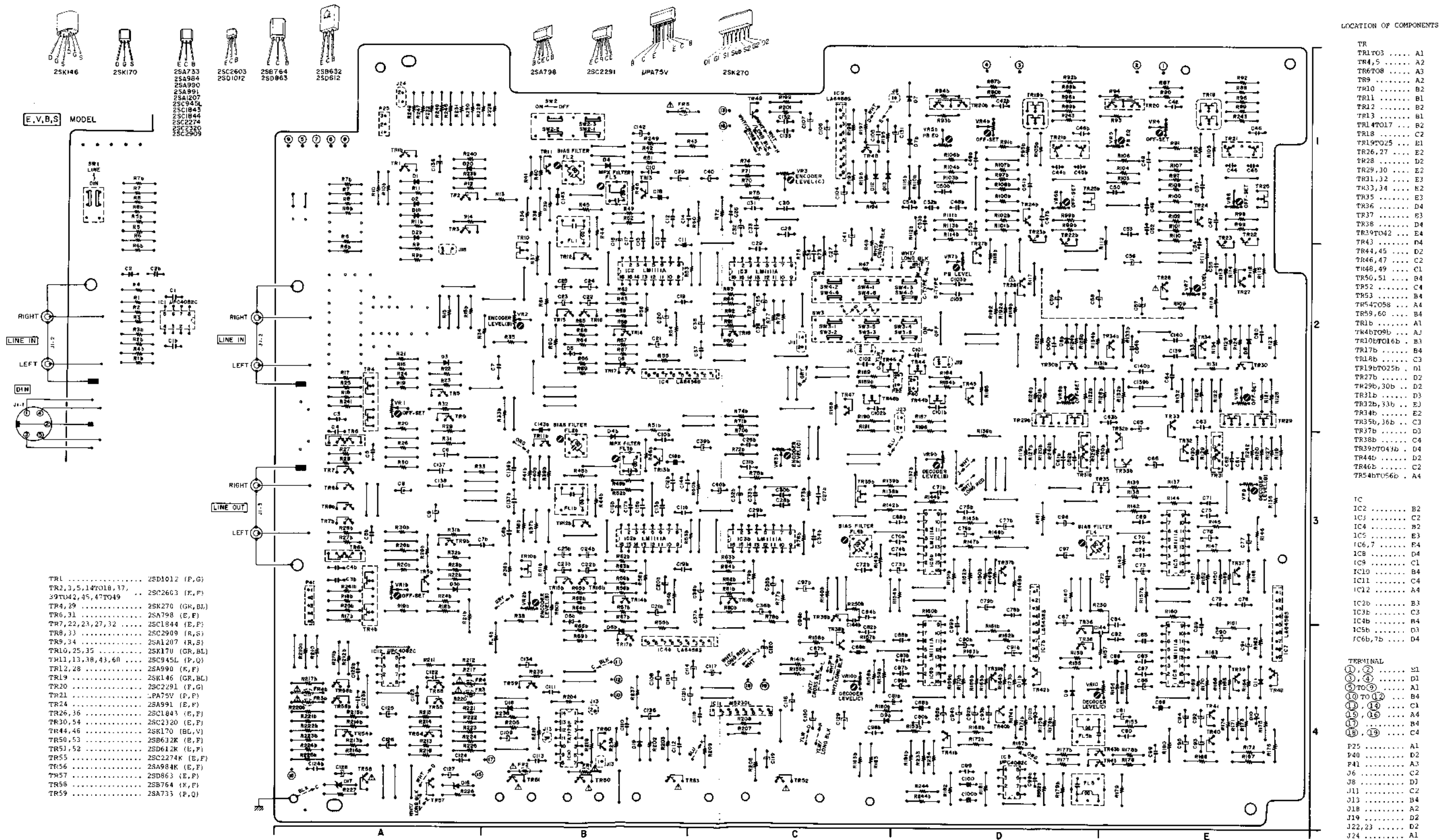

WARNING ⚠ INDICATES SAFETY CRITICAL COMPONENTS. FOR CONTINUED SAFETY, REPLACE SAFETY CRITICAL COMPONENTS ONLY WITH MANUFACTURER'S RECOMMENDED PARTS.

AVERTISSEMENT ⚠ IL INDIQUE LES COMPOSANTS CRITIQUES DE SÛRETÉ. POUR MAINTENIR LE DEGRÉ DE SÛRETÉ DE L'APPAREIL, NE REMPLACER LES COMPOSANTS DONT LE FONCTIONNEMENT EST CRITIQUE POUR LA SÛRETÉ QU'IL PAR DES PIÈCES RECOMMANDÉES PAR LE FABRICANT.

2) TUNING P.C BOARD T2033A5070 (3ED)

LOCATION OF COMPONENTS

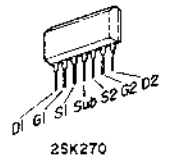
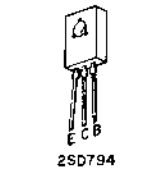
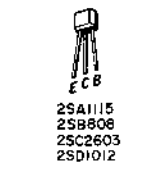
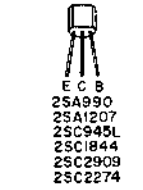
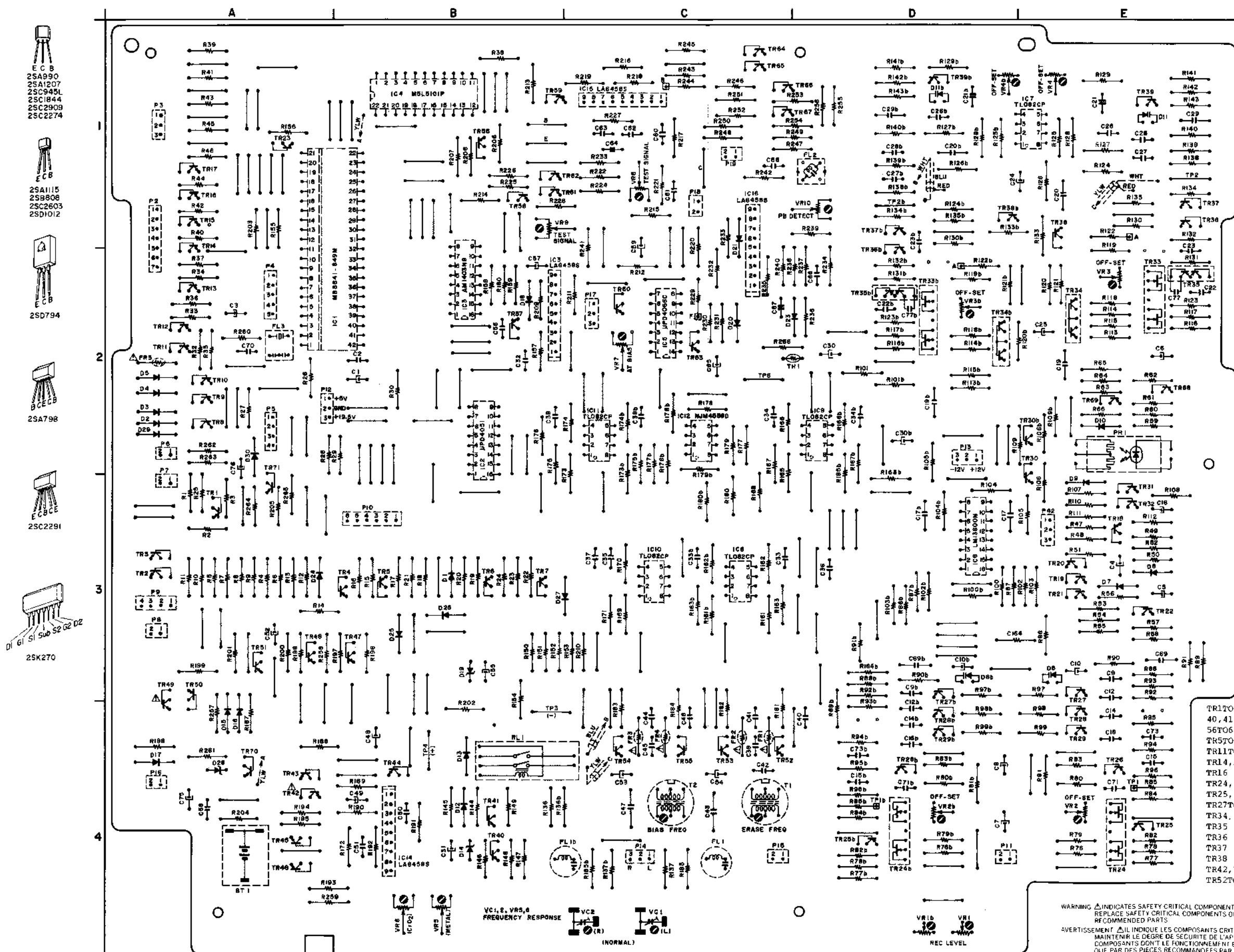

IC

IC1	A,B-1,2
IC2,3	B2
IC4	B1
IC5	C2
IC6	D3
IC7	B1
IC8	C3
IC9	D2
IC10	C3
IC11,12	C2
IC13	B2
IC14	B4
IC15	C1
IC16	C1,2

TR

TR1TO3	A3
TR4TO7	B3
TR8TO13	A2
TR14TO17	A1
TR18TO22	E3
TR23	A1
TR24TO26	E4
TR27	E3
TR27b	D3
TR28,29	E4
TR28b,29b	D4
TR30TO32	E3
TR30b	E2
TR33TO35	E2
TR33bTO36b	D2
TR36TO39	E1
TR37bTO39b	D1
TR40,41	B4
TR42,43	A4
TR44	B4
TR45,46	A4
TR47	B3
TR48TO51	A3
TR52TO55	C4
TR56	B1
TR57	B2
TR58,59	B1
TR60	C2
TR61,62	B1
TR63	C2
TR64TO67	C1
TR68,69	E2
TR70	A4
TR71	A3

CONNECTOR

P2,3	A1
P4TO6	A2
P7TO9	A3
P10	B3
P11	D4
P12	A2
P13	D2
P14,15	C4
P16	A4
P17	C2
P18,19	C1
P42	E3

TR1TO4,18TO23,31,32,40,41,43TO48,50,51,56TO60,63TO68	25C2603 (F,G)
TR5TO10,69	25A1115 (E,F)
TR11TO13	25B808-7 (G,H)
TR14,15,17,30,61,62	25D1012-V (G,H)
TR16	25D1012-V (H)
TR24,33	25K270 (GR,BL)
TR25,26	25A990 (E,F)
TR27TO29,39,71	25C945L (P,Q)
TR34	25C2291 (F,G)
TR35	25A798 (E,F)
TR36	25C1844 (E,F)
TR37	25C2909 (R,S)
TR38	25A1207 (R,S)
TR42,70	25D794 (P,Q)
TR52TO55	25C2274 (F)

WARNING: Δ INDICATES SAFETY CRITICAL COMPONENTS FOR CONTINUED SAFETY. REPLACE SAFETY CRITICAL COMPONENTS ONLY WITH MANUFACTURER'S RECOMMENDED PARTS.

AVERTISSEMENT: Δ INDIQUE LES COMPOSANTS CRITIQUES DE SÛRETÉ. POUR MAINTENIR LE DEGRÉ DE SÛRETÉ DE L'APPAREIL, NE REMPLACER LES COMPOSANTS DON'T LE FONCTIONNEMENT N'EST CRITIQUE POUR LA SÛRETÉ QU'É PAR DES PIÈCES RECOMMANDÉES PAR LE FABRICANT.

3) SYSCON P.C BOARD T2033B506A (3ED), INTERMEDIATE P.C BOARD T2033B506B, MODE P.C BOARD T2033B506C and REC PAUSE P.C BOARD T2033D5160

TR1 -----2SC945L(Q,P)
 TR8, 9, 15, 21 to 25, 29, 33 --2SC2603(E,F)
 TR10 to 14, 19, 20 -----2SD1012V(G,H)
 TR16, 17, 31, 32 -----2SB808V(G,H)
 TR27, 30 -----2SA733A(P,Q)

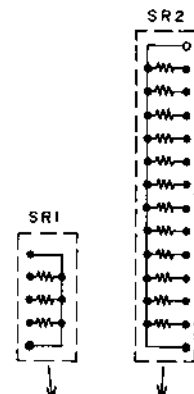
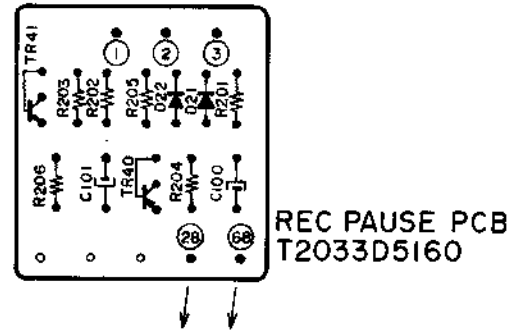
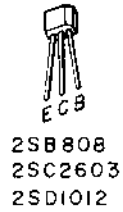
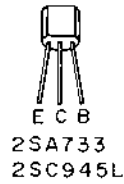

LOCATION OF COMPONENTS

Component	Location	Component	Location	Terminal	Location
TR1	D1	IC		1 TO 4	D1
TR8	B1	IC1	D1	7 TO 9	D1
TR9	C2	IC2	D2	10 TO 21	A2
TR10	B2	IC3	A2	22 TO 29	A1
TR11 TO 15	C2	IC4	A1	31 TO 38	B1
TR16, 17	C1	IC5	A2	39	C1
TR19, 20	C2	IC6	B1	40 TO 42	B1
TR21, 22	A2	IC7	B2	43 TO 49	C1
TR23, 24	C1	IC8	B1, 2	50, 51	A1
TR25	C2	IC9	C1	52	A2
TR27	A1	IC10	D1	53	C1
TR29, 30	C2			55	A1
TR31 TO 33	C1			56	B1
				57	A1
				58 TO 63	B2
				64 TO 66	C1
				67, 68	A1
				J4- 1	B2
				J4- 2 TO 4	A1
				J4- 5	B2
				J7	A2
				J16- 1	A1
				J16- 2	B2
				J42- 1	B2
				J42- 2, 3	B1

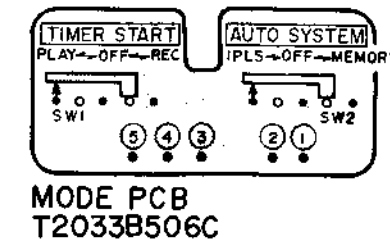
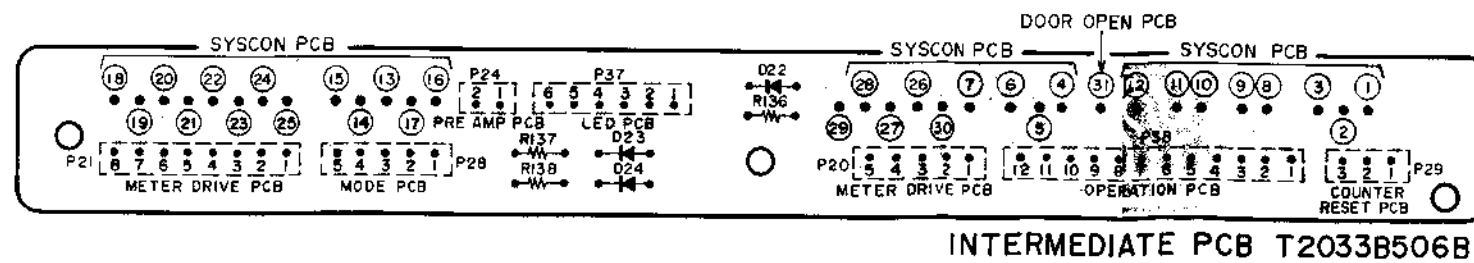
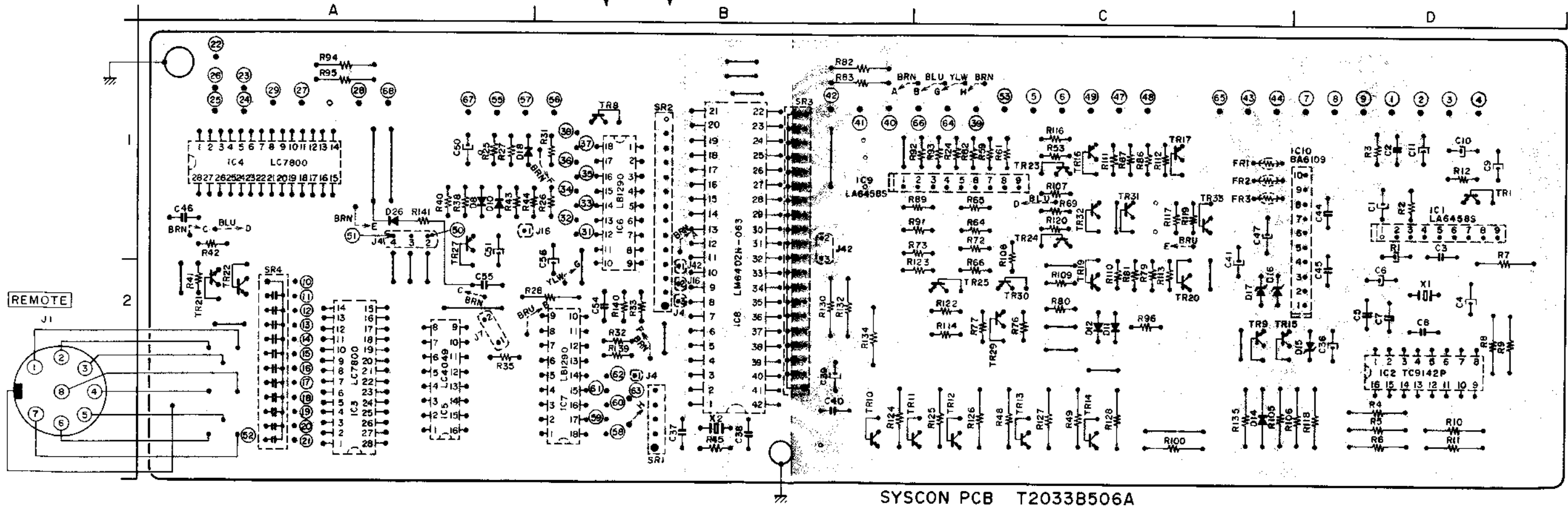

4) METER DRIVE P.C BOARD T2033B5040 (2ED)

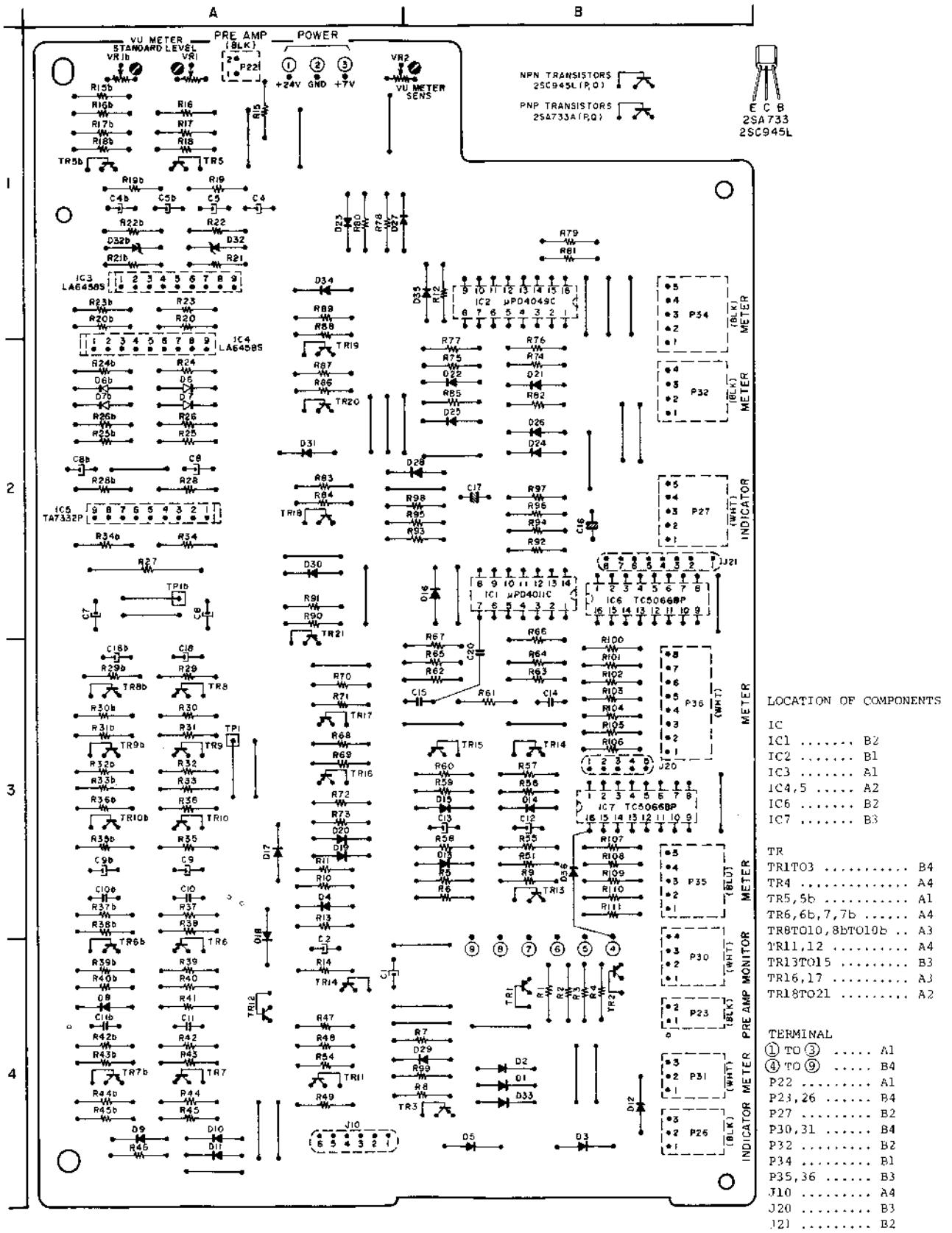

5) INDICATOR P.C BOARD T2033C5020

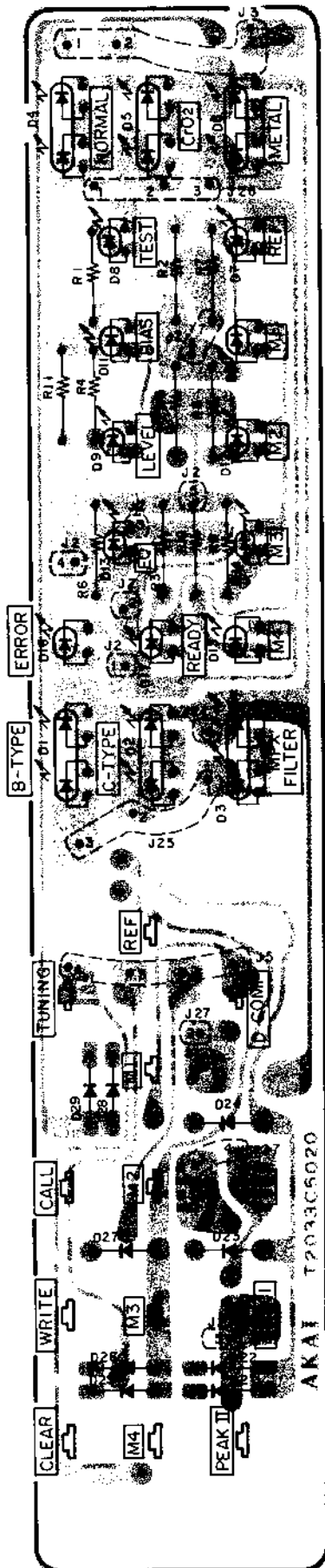

6) METER P.C BOARD T2033B5030

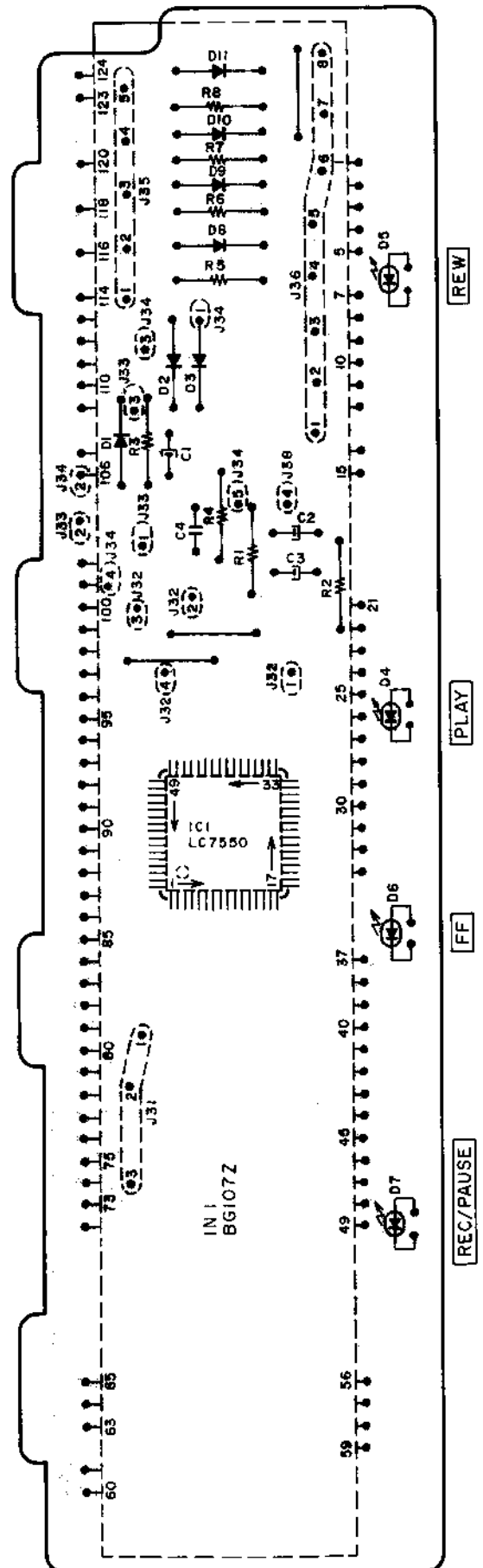

7) OPERATION P.C BOARD T2033B5050

8) LED P.C BOARD T2033C5090

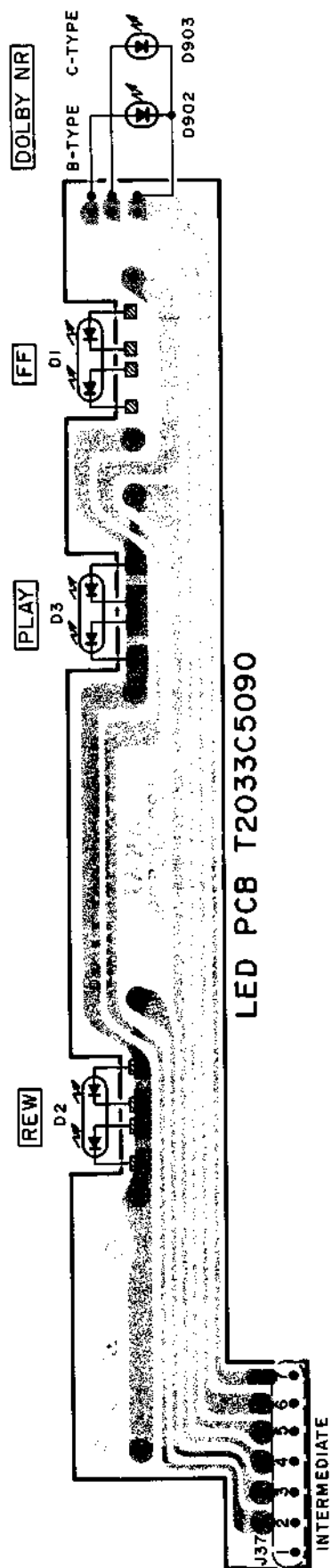
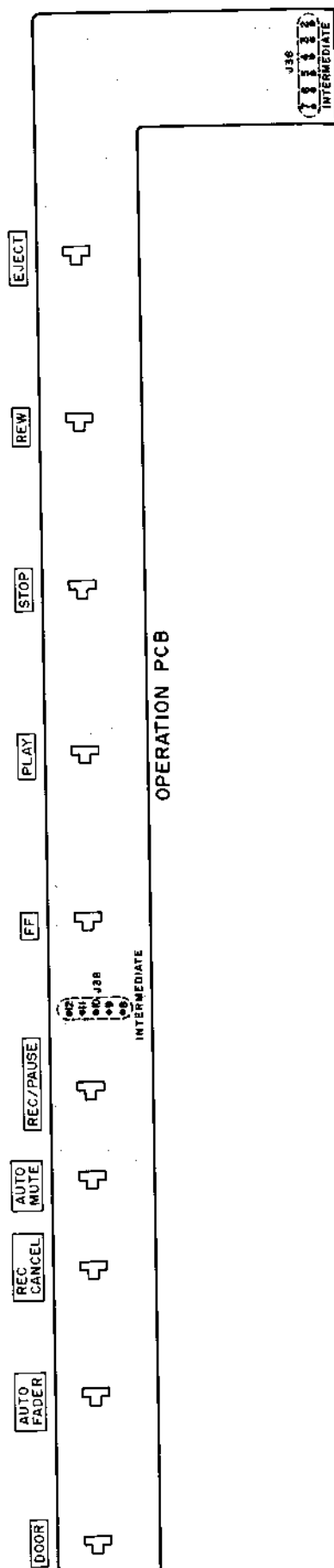

9) POWER SUPPLY P.C BOARD T2033B5010 (3ED)

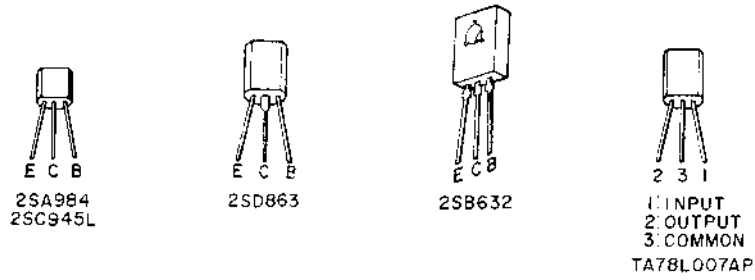

U AC110V to 240V
50/60HZ

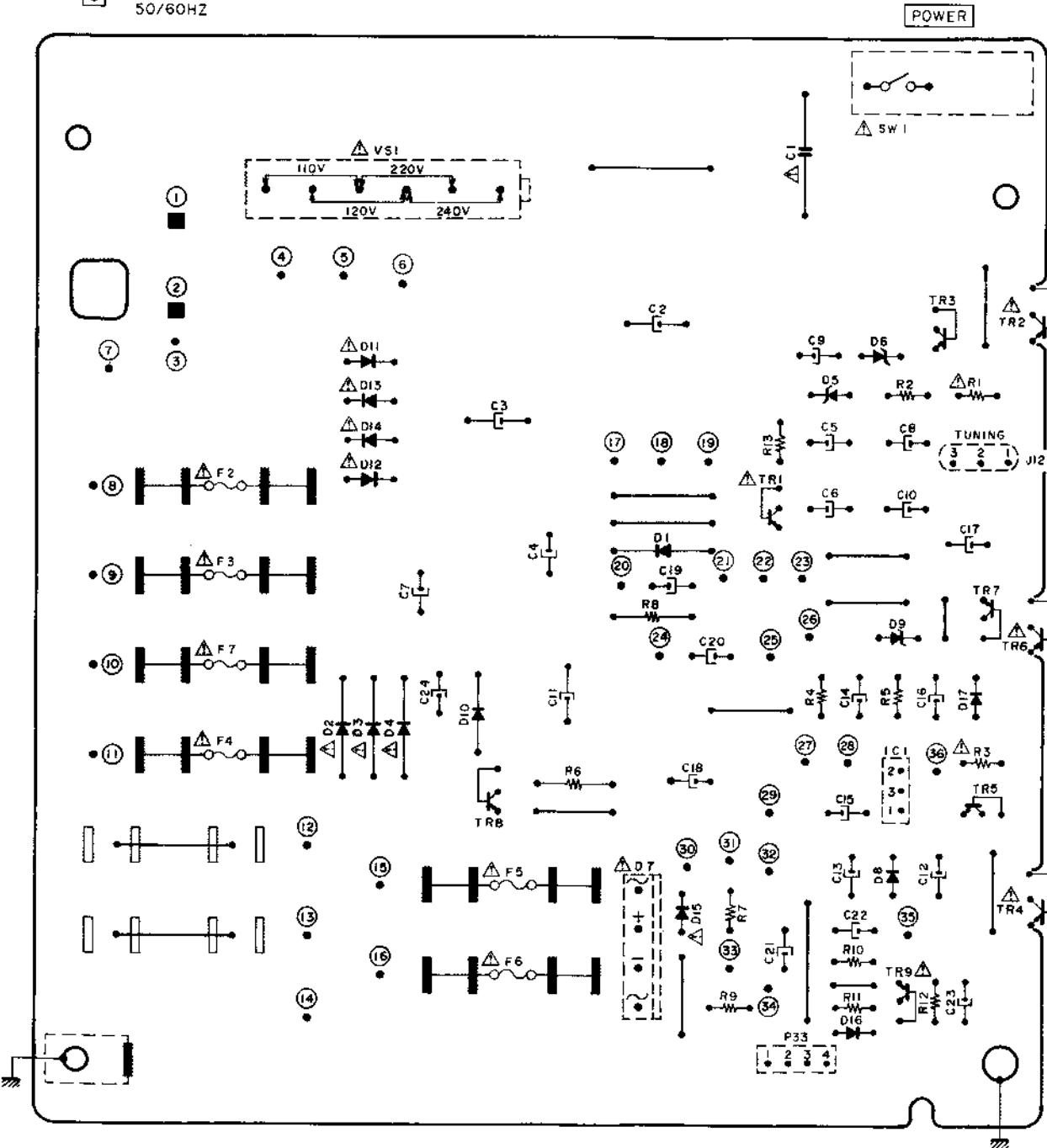

WARNING Δ INDICATES SAFETY CRITICAL COMPONENTS FOR CONTINUED SAFETY.
REPLACE SAFETY CRITICAL COMPONENTS ONLY WITH MANUFACTURER'S
RECOMMENDED PARTS

AVERTISSEMENT: Δ IL INDIQUE LES COMPOSANTS CRITIQUES DE SÛRETÉ POUR
MAINTENIR LE DÈGRE DE SÛRETÉ DE L'APPAREIL NE REMPLACER LES
COMPOSANTS DON'T LE FONCTIONNEMENT EST CRITIQUE POUR LA SÛRETÉ
QUÉ PAR DES PIÈCES RECOMMANDÉES PAR LE FABRICANT

IC1 ---- TA78L007AP
TR1 ---- 2SD863-V8 (F1)
TR2,4,5 ---- 2SB632K (E,F)
TR3,5,7,9 ---- 25C945L (F,Q)
TR8 ---- 2SA984K (F)

10) MOTOR P.C BOARD M3103C726A and POTENTION P.C BOARD M3103C726B

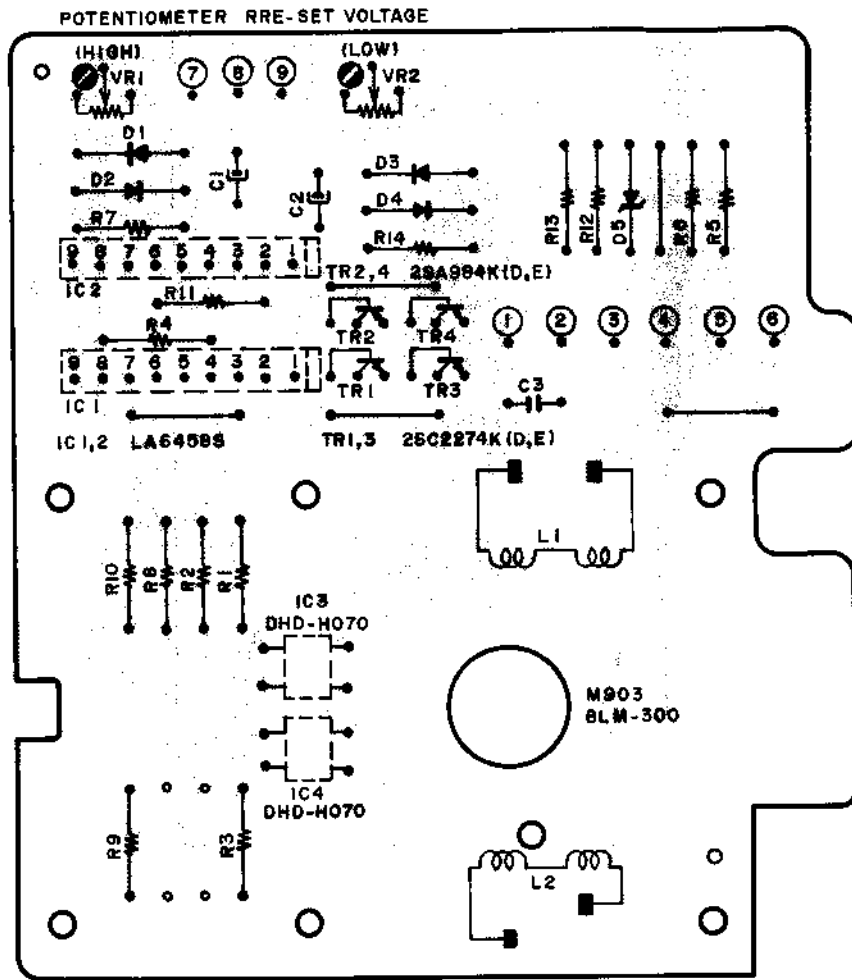

MOTOR PCB M3103C726A

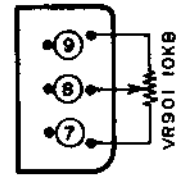
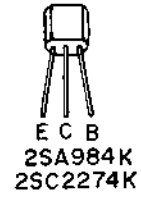

POTENTION PCB M3103C726B

11) FG P.C BOARD M3103C7130

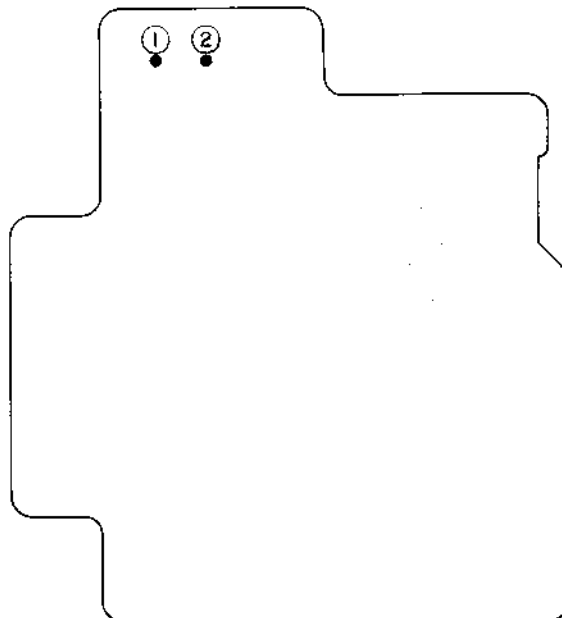

12) DOOR OPEN P.C BOARD T2033C5100

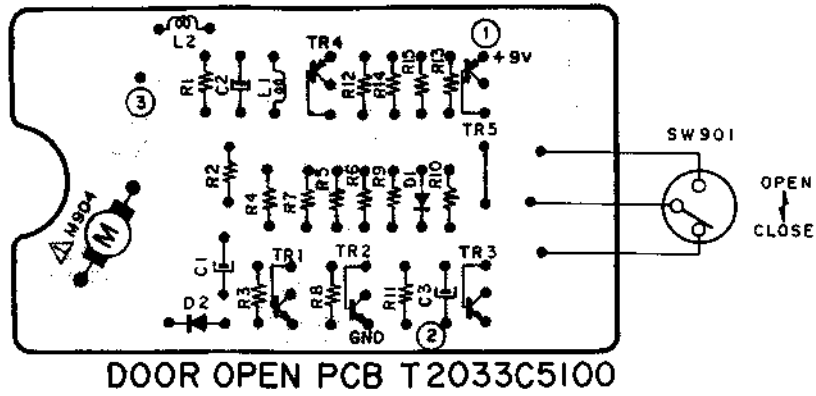

WARNING Δ INDICATES SAFETY CRITICAL COMPONENTS FOR CONTINUED SAFETY. REPLACE SAFETY CRITICAL COMPONENTS ONLY WITH MANUFACTURER'S RECOMMENDED PARTS.
 AVERTISSEMENT: Δ IL INDIQUE LES COMPOSANTS CRITIQUES DE SÛRETÉ POUR MAINTENIR LE DEGRÉ DE SÛRETÉ DE L'APPAREIL. NE REMPLACER LES COMPOSANTS DON'T LE FONCTIONNEMENT EST CRITIQUE POUR LA SÛRETÉ QUE PAR DES PIÈCES RECOMMANDÉES PAR LE FABRICANT.

13) MONITOR P.C BOARD T2033D5110

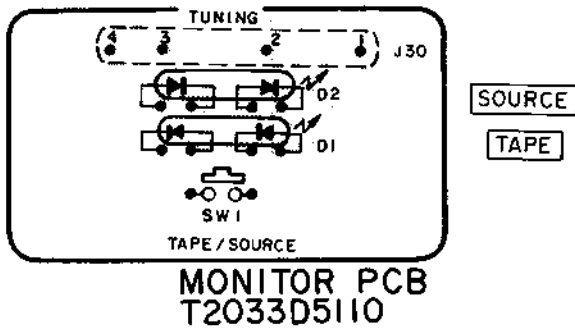

14) COUNTER RESET P.C BOARD T2033D5120

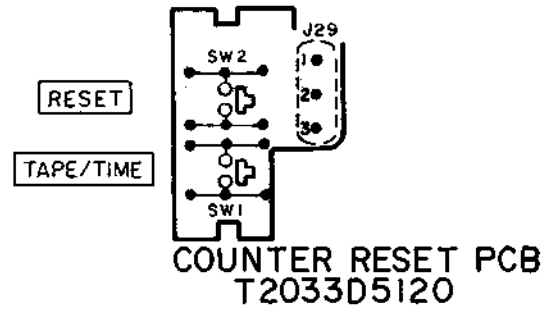

15) FILTER P.C BOARD T2029D5040

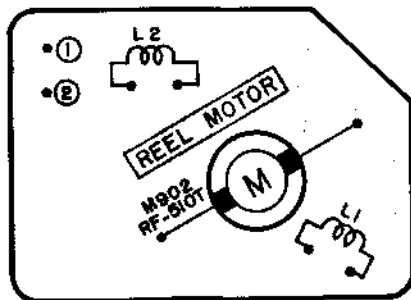

16) DETECTOR P.C BOARD T2029D5030

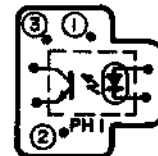

17) MICRO SW P.C BOARD T2029D5020

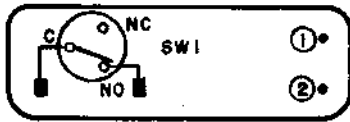

18) HEAD PHONE P.C BOARD T2033A508B

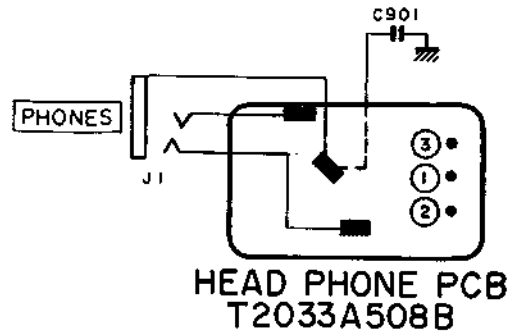

19) INPUT P.C BOARD T2033D5150

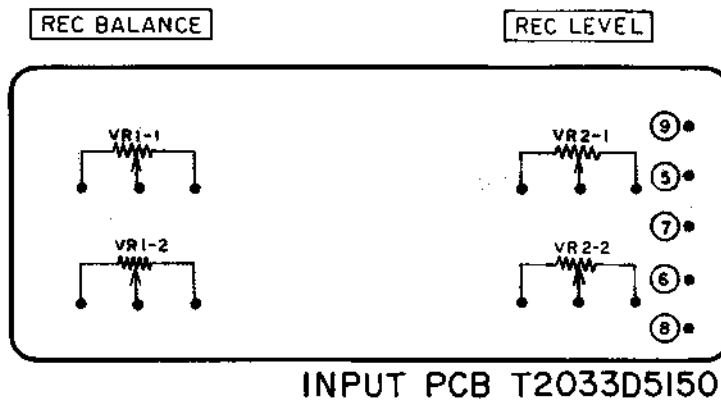

20) OUTPUT P.C BOARD T2033D5140

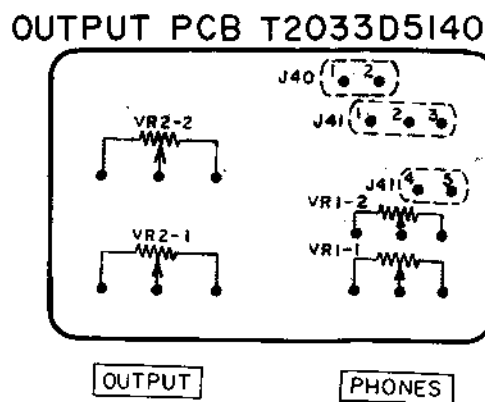

MEMO

MEMO

MEMO

MEMO

SECTION 3

PARTS LIST

TABLE OF CONTENTS

RECOMMENDED SPARE PARTS	59
1. MECHA BLOCK	60
2. MOTOR BLOCK	62
3. PRE AMP P.C BOARD BLOCK	64
4. SYS. CON. P.C BOARD BLOCK	65
5. TUNING P.C BOARD BLOCK	66
6. POWER P.C BOARD BLOCK	67
7. METER DRIVE P.C BOARD BLOCK	67
8. METER P.C BOARD BLOCK	67
9. MOTOR P.C BOARD BLOCK	67
10. INDICATOR P.C BOARD BLOCK	67
11. DOOR OPEN P.C BOARD BLOCK	67
12. MONITOR P.C BOARD BLOCK	67
13. DOOR BLOCK	68
14. ASSEMBLY BLOCK	70
15. FINAL ASSEMBLY BLOCK	72
INDEX	73

Resistor and Capacitor which is not listed in this parts list, please refer to COMMON LIST FOR SERVICE PARTS.

ATTENTION

1. When placing an order for parts, be sure to list the parts no., model no., and description. There are instances in which if any of this information is omitted, parts cannot be shipped or the wrong parts will be delivered.
2. Please be careful not to make a mistake in the parts no. If the parts no. is in error, a part different from the one ordered may be delivered.
3. Because parts number and parts unit supply in the Preliminary Parts List may be partially changed, please use this parts list for all future reference.

HOW TO USE THIS PARTS LIST

1. This Parts List shows the parts that are considered necessary for repairs. Other parts, such as resistors and capacitors, are shown in the "Common List for Service Parts". Select and order such parts from the "Common List for Service Parts".
2. The Recommended Spare Parts shows those parts in the Parts List which are considered particularly important for service.
3. Parts not shown in the Parts List and "Common List for Service Parts" will not be supplied in principle.
4. How to read list

a) Mechanism Block

b) P.C Board Block

2. HEAD BASE BLOCK

REF. NO.	PARTS NO.	DESCRIPTION
2-1x	BH-T2023A320A	HEAD BASE BLOCK GX-F66R
2-2	HP-H2206A010A	HEAD R/P PR4-8FU C
2-3	ZS-477876	PAN20x03STL CMT
2-4	ZS-536488	BID20x08STL CMT
2-5	ZG-402895	CS ANGLE ADJUST SPRING

SP (Service Parts) Classification

A small "x" indicates the inability to show that particular part in the Photo or Illustration.

This number corresponds with the individual parts index number in that figure

This number corresponds with the Figure Number

6. SYS. CON. P.C BOARD BLOCK

REF. NO.	PARTS NO.	DESCRIPTION
6-1	BA-T2034A070A	PC SYS CON BLK GX-F44R
6-IC1	EI-324536	IC HD14049BP
6-IC2	EI-336801	IC MB8841-564M
6-IC3	EI-331661	IC SN7405N
6-IC4	EI-336725	IC M54527P
6-TR1to4	ET-200985	TR 2SC2603 F,G
6-TR5to28	ET-554657	TR 2SA733A P,Q
6-D1	ED-318292	D SILICON H 1S2473T-77 T26
6-D2to4	ED-308952	D GERMA V 1K34A-LR F07
6-D5to10	ED-318292	D SILICON H 1S2473T-77 T26
6-X1	EI-318384	OSC X'TAL NC-18C 3.579545MHZ

SP (Service Parts) Classification

This reference numbers corresponds with symbol numbers of Schematic Diagrams.

5. Both the kind of part and installation position can be determined by the Parts Number. To determine where a parts number is listed, utilize Parts Index at end of Parts List. It is necessary first of all to find the Parts Number. This can be accomplished by using the Reference Number listed at right of parts number in the Parts Index.

WARNING

▲ INDICATES SAFETY CRITICAL COMPONENTS. FOR CONTINUED SAFETY, REPLACE SAFETY CRITICAL COMPONENTS ONLY WITH MANUFACTURER'S RECOMMENDED PARTS.

AVERTISSEMENT

▲ IL INDIQUE LES COMPOSANTS CRITIQUES DE SURETE. POUR MAINTENIR LE DEGRE DE SECURITE DE L'APPAREIL, NE REMPLACER LES COMPOSANTS DONT LE FONCTIONNEMENT EST CRITIQUE POUR LA SECURITE QUE PAR DES PIECES RECOMMANDEES PAR LE FABRICANT.

RECOMMENDED SPARE PARTS

Because, if the parts listed below are on hand, almost any repair can be accomplished, we suggest that you stock these Recommended Spare Parts Items.

NO.	PARTS NO.	DESCRIPTION	NO.	PARTS NO.	DESCRIPTION	NO.	PARTS NO.	DESCRIPTION
1	AX-336835	BATTERY 2/60DK	64	EF-327103	△ FUSE TSC A 250V 0.50A (U,J) (F4)	128	ET-338446	TR μPA75V P,F
2	BF-B336024	FLYWHEEL (A) PART	65	EF-327103	△ FUSE TSC A 250V 0.50A (U,J) (F7)	129	ET-200558	TR 2SA1115 E,F
3	BH-T2033A360A	△ HEAD BLK GX-F91	66	EF-309388	△ FUSE TSC A 250V 0.80A (U,J) (F2,3)	130	ET-338244	TR 2SA1207 R,S
4	BM-B336989	△ REEL MOTOR (PULLEY) PART	67	EF-306949	△ FUSE TSC A 250V 1.25A (U,J) (F5,6)	131	ET-554657	TR 2SA733A P,Q
5	BM-T2030A120A	△ REEL MOTOR BLK GX-F51	68	EF-309391	△ FUSE TSC 125V 0.08A (C,A) (F2,3)	132	ET-338180	TR 2SA798 E,F
6	BM-M3104A010A	△ MOTOR BLM-310	69	EF-315334	△ FUSE TSC 125V 0.25A (C,A) (F8,9)	133	ET-337012	TR 2SA984K D,E
7	BM-337351	△ MOTOR M32E-1	70	EF-309390	△ FUSE TSC 125V 0.50A(C,A) (F7)	134	ET-324134	TR 2SA984K E,F
8	BM-B337064	△ MOTOR OPERATION (PULLEY) PART	71	EF-309390	△ FUSE TSC 125V 0.50A(C,A) (F4)	135	ET-337760	TR 2SA984K F
9	BR-342719	REEL TABLE (B) ASSY	72	EF-309392	△ FUSE TSC 125V 1.25A (C,A) (F5,6)	136	ET-337967	TR 2SA990 E,F
10	BR-336606	REEL TABLE ASSY	73	EI-337568	HOLE ELEMENT DHD-H070	137	ET-338447	TR 2SA991 E,F
11	BT-337115	△ TRANS POWER T2033-A.C (C,A)	74	EI-328690	IC AM1408N8	138	ET-322598	TR 2SB632K E,F
12	BT-337117	△ TRANS POWER T2033-B.S (B,S)	75	EI-330352	IC BA6109	139	ET-318237	TR 2SB764 E,F
13	BT-337116	△ TRANS POWER T2033-E.V (E,V)	76	EI-336761	IC LA6458S	140	ET-336997	TR 2SB808-V G,H
14	BT-337114	△ TRANS POWER T2033-J (J)	77	EI-337013	IC LB1290	141	ET-337258	TR 2SC1843 E,F
15	BT-337113	△ TRANS POWER T2033-U (U)	78	EI-337009	IC LC4049	142	ET-308954	TR 2SC1844 E,F
16	BZ-T2033A340A	MECHA BLK GX-F91	79	EI-325755	IC LC7550	143	ET-309353	TR 2SC2274 E,F
17	BZ-T2030A110A	OIL CLUTCH BLK GX-F51	80	EI-337008	IC LC7800	144	ET-337011	TR 2SC2274K D,E
18	EC-338341	C COMP 05-0034	81	EI-306009	IC LM1111A	145	ET-308977	TR 2SC2274K F
19	EC-300034	C S-FIX H ECR-CA100H12 9.0-100	82	EI-337370	IC LM13600N	146	ET-338350	TR 2SC2291 F,G
20	EC-337017	OSC CE CSB800A 0.8MHZ	83	EI-337006	IC LM6402H-063	147	ET-200505	TR 2SC2603 E,F
21	ED-308953	D GERMA H 1K34A-LH SNP	84	EI-337118	IC MB8841-649M	148	ET-200985	TR 2SC2603 F,G
22	ED-308952	D GERMA V 1K34A-LR F07	85	EI-330475	IC M5L510P	149	ET-639437	TR 2SC945L Q,P
23	ED-337092	D LED GL-9HY4 YLW	86	EI-336994	IC M5230L	150	ET-328437	TR 2SD1012-V F,G
24	ED-337093	D LED GL-9NG4 GRN	87	EI-213390	IC NJM4558D	151	ET-328868	TR 2SD1012-V G,H
25	ED-328791	D LED GL-9PR4 RED	88	EI-201940	IC NJM4558S	152	ET-338324	TR 2SD1012-V H
26	ED-337101	D LED LT9200H YLW	89	EI-314647	IC TA7179P	153	ET-310148	TR 2SD612K E,F
27	ED-337091	D LED LT9200N GRN	90	EI-337126	IC TA7332P	154	ET-307349	TR 2SD794 P,Q
28	ED-312101	D LED SG238D GRN	91	EI-337329	IC TA78L007AP	155	ET-328440	TR 2SD863-V8 E,F
29	ED-337010	D LED SLF-201C GRN	92	EI-315379	IC TC5066BP	156	EV-341209	R S-FIX H CR19R 3P 0.50W 101
30	ED-332243	D LED SLP-171D RED	93	EI-337124	IC TC9142	157	EV-623193	R S-FIX H CR19R 3P 0.50W 222
31	ED-336786	D LED SLP-271D GRN	94	EI-324255	IC TL082CP	158	EV-312338	R S-FIX H CR19R 3P 0.50W 223
32	ED-312108	D LED SR538D RED	95	EI-337360	IC μPC4082C	159	EV-648753	R S-FIX H CR19R 3P 0.50W 473
33	ED-337330	D LED SY438D YLW	96	EI-304164	IC μPD4011C	160	EV-301729	R S-FIX H CR19R 3P 0.50W 681
34	ED-301911	D SILICON H DS448	97	EI-319555	IC μPD4049C	161	EV-315416	R S-FIX H D8 3P 103
35	ED-200469	D SILICON H DS448 FA5 F10	98	EI-338238	IC μPD4051	162	EV-321637	R S-FIX H D8 3P 104
36	ED-200212	D SILICON H DS448Fx2 F07	99	EI-317653	IC μPD4066C	163	EV-314646	R S-FIX H D8 3P 202
37	ED-330987	D SILICON RB152 200/1.5A	100	EI-337123	OSC X TAL 4.04727MHZ	164	EV-315752	R S-FIX H D8 3P 204
38	ED-200468	D SILICON V DS448-VB6	101	EL-337053	PL CORD 16.0V 80MA 400/400	165	EV-315413	R S-FIX H D8 3P 503
39	ED-306109	D SILICON W03B 100/1.0A	102	EP-328529	RELAY LEAD LAB2NS 2NO 12V	166	EV-330369	R S-FIX H SR19R 3P 0.15W 222
40	ED-330622	D SILICON 1SR35-100VL 100/1.0A	103	ER-337380	FILTER CE KMFC-100IS 3.580MHZ	167	EV-483377	R S-FIX H SR19R 3P 0.15W 473
41	ED-338322	D SILICON 10DF1 100/1.0A	104	ER-328490	FILTER DB D07-001K 19KHZ	168	EV-338570	R S-FIX V RVX0911 3P 503
42	ED-337090	D VARACTOR KV-1236	105	ER-328491	FILTER DB D07-003K 100KHZ	169	EV-522663	R S-FIX V V8K1-1 3P 104
43	ED-306983	D ZENER H HZ12 C3	106	ER-337376	R COMP 01-0399	170	EV-464253	R S-FIX V V8K1-1 3P 202
44	ED-331198	D ZENER H HZ3 A1	107	ER-337374	R COMP 01-0400	171	EV-572422	R S-FIX V V8K1-1 3P 203
45	ED-338332	D ZENER H HZ4 A2	108	ER-337631	R COMP 01-0449	172	EV-337310	VR DETENT 00P20x0A A503
46	ED-338333	D ZENER H HZ5 B2	109	ER-318647	R FUSE ERD2FC F10 1/4W 4R7J	173	EV-337313	VR DETENT 00P20x0B B502
47	ED-337268	D ZENER H HZ5A-1	110	ES-336990	SW LEAF BSW-169 01-1 NO	174	EV-337312	VR DETENT 01P20x0A M503 N503
48	ED-331617	D ZENER H HZ6 A3	111	ES-337344	SW MICRO SS-01-ED UC	175	EV-337314	VR ROTARY 12P20x0C A203
49	ED-302295	D ZENER H HZ7 C3	112	ES-691457	SW MICRO VU-SR	176	EV-337052	VR ROTARY 16L10xOR B103
50	ED-337266	D ZENER H HZ9A-1	113	ES-312234	SW PUSH SDL-1P 01-1 E	177	EV-337106	VR ROTARY 16L10xOT B103
51	ED-338540	D ZENER V HZ20-2S1	114	ES-312235	SW PUSH SDL-1P 01-1 J	178	HE-337372	HEAD E E-3621-PR C
52	ED-338013	D ZENER V HZ24-3S1	115	ES-312238	SW PUSH SDL-1P 01-1 UC	179	HP-H2402A010A	HEAD COMBO PR4-5 C
53	ED-338082	D ZENER V HZ5C-1S1	116	ES-337311	SW PUSH SUN192A 2-04-02S	180	MB-336026	BELT CAPSTAN
54	ED-338318	D ZENER V HZ7C-3S1	117	ES-337319	SW PUSH SUN192A 2-06-02N	181	MB-666123	BELT DRIVE
55	ED-338083	D ZENER V HZ9C-3S1	118	ES-337232	SW ROTARY SBM1023N 2-02-03N	182	MB-336021	BELT OPERATION
56	ED-338477	THERMISTOR 112503-2	119	ES-283072	SW SLIDE SSC22LP 2-02-02N	183	MI-336025	FLYWHEEL (B)
57	EF-300588	△ FUSE EAWK T 250V 0.20A (E,B,S,V) (F8,9)	120	ES-309311	SW TACT KEG10904	184	MP-336153	PINCH ROLLER (A)
58	EF-695766	△ FUSE SEMKO T 250V 0.31A (E,B,S,V) (F1)	121	ES-336780	SW TACT KHH10902	185	MP-336204	PINCH ROLLER (B)
59	EF-593706	△ FUSE SEMKO T 250V 0.50A (E,B,S,V) (F4)	122	ET-337359	PHOTO SENSOR MCD-7213P	186	TC-T2033A040A	CLUTCH BLK GX-F91
60	EF-593706	△ FUSE SEMKO T 250V 0.50A (E,B,S,V) (F7)	123	ET-311977	PHOTO SENSOR SPI-201	187	TC-336002	HOLDER CAPSTAN (B)
61	EF-258344	△ FUSE SEMKO T 250V 0.80A (E,B,S,V) (F2,3)	124	ET-337111	TR FET 2SK146 GR, BL	188	TC-B336004A	HOLDER CAPSTAN (C-1) PART
62	EF-602550	△ FUSE SEMKO T 250V 1.25A (E,B,S,V) (F5,6)	125	ET-341400	TR FET 2SK170 BL, GR	189	TC-336605	WIND IDLER ASSY
63	EF-308933	△ FUSE TSC A 250V 0.20A (J) (F8,9)	126	ET-337235	TR FET 2SK170 BL,V			
			127	ET-337234	TR FET 2SK270 GR, BL			

When ordering parts, please quote Parts Number, Description and Model Number.

MECHA BLOCK

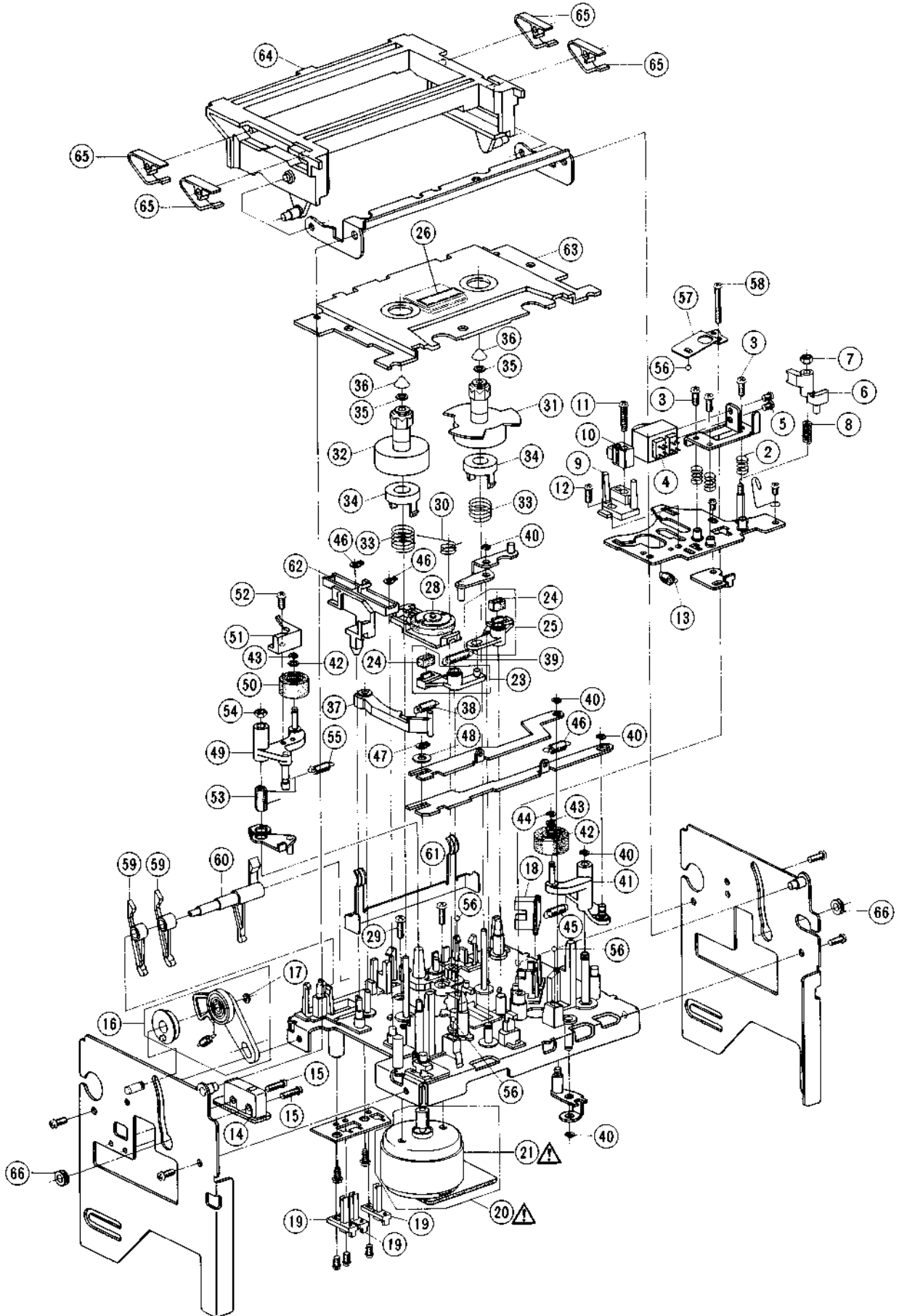

1. MECHA BLOCK

REF. NO.	PARTS NO.	DESCRIPTION	REF. NO.	PARTS NO.	DESCRIPTION
HEAD BLOCK					
1-1x	BH-T2033A360A	HEAD BLK GX-F91	1-55	ZG-336208	SP PULL PINCH ROLLER (S)
1-2	ZG-336127	SP PUSH HEAD	1-56	MV-357208	BALL200STL
1-3	ZS-608095	PAN20x05STL CMT	1-57	ZG-336157	SP PLATE HEAD HOLD
1-4	HP-H2402A010A	HEAD COMBO PR4-S C	1-58	ZS-342002	ST PAN26x16STL CMT
1-5	ZS-477876	PAN20x03STL CMT	1-59	ML-336158	LEVER DETECTION (B)
1-6	HZ-336129	GUIDE TAPE	1-60	ML-336159	LEVER DETECTION (A)
1-7	ZW-618884	N20STL CMT 1	1-61	ZG-336160	SP PLATE CASSETTE HOLDER (A)
1-8	ZG-336130	SP PUSH GUIDE	1-62	TC-336161	SLIDE EJECT
1-9	HZ-336195	HOLDER HEAD E	1-63	BD-B336162A	LED DECORATION (A) PART
1-10	HE-337372	HEAD E E-3621-PR C	1-64	SP-336163	LID CASE
1-11	ZS-342086	PLX PAN26x12STL CMT	1-65	ZG-336615	SP PLATE CASSETTE HOLDER (B)
1-12	ZS-499331	PAN23x05STL CMT	1-66	SZ-336166	COLLAR LID
1-13	ZG-341972	SP PULL HEAD RETURN			
SW MICRO P.C BOARD BLOCK					
1-14	ES-337344	SW MICRO SS-01-ED UC (SW1)			
CHASSIS MECHA SIDE (L) BLOCK					
1-15	ZS-310337	PAN20x08STL CMT			
1-16	BZ-T2030A110A	OIL CLUTCH BLK GX-F51			
1-17	ZW-270088	RING E 190SUP CMT			
DETECTION P.C BOARD BLOCK					
1-18	ET-311977	PHOTO SENSOR SPI-201 (PH1)			
SW LEAF BLOCK					
1-19	ES-336990	SW LEAF BSW-169 01-1 NO (SW902, 903, 905)			
REEL MOTOR BLOCK					
1-20	BM-T2030A120A	△ REEL MOTOR BLK GX-F51			
1-21	BM-B336989	△ REEL MOTOR (PULLEY) PART			
1-22x	EO-669273	COIL FIX 2 FL5R200 18μH			
LEVER BRAKE (A) BLOCK					
1-23	BL-T2030A160A	LEVER BRAKE (A) BLK GX-F51			
1-24	TC-336146	BRAKE RUBBER			
LEVER BRAKE (B) BLOCK					
1-25	BL-T2030A170A	LEVER BRAKE (B) BLK GX-F51			
D LED BLOCK					
1-26	ED-337010	D LED SLF-201C GRN (D901)			
MECHA BLOCK					
1-27x	BZ-T2033A340A	MECHA BLK GX-F91			
1-28	TC-336605	WIND IDLER ASSY			
1-29	ZS-563444	BID26x08STL CMT			
1-30	ZG-336140	SP TORSION IDLER			
1-31	BR-336606	REEL TABLE ASSY			
1-32	BR-342719	REEL TABLE (B) ASSY			
1-33	ZG-336141	SP PUSH BT			
1-34	TC-336142	HOLDER BT SP			
1-35	ZW-330073	PW21x040x020			
1-36	MT-305793	REEL CAP			
1-37	BL-B336196	LEVER BT PART			
1-38	ZG-324331	SP T2-3.2/0.2-12.5 T2-041			
1-39	ZG-312946	SP T1-3.2/0.29-16.0 T1-062			
1-40	ZW-270088	RING E 190SUP CMT			
1-41	BL-B336150	ARM PINCH ROLLER (A) PART			
1-42	MP-336153	PINCH ROLLER (A)			
1-43	ZW-381644	PW21x040x013PSL			
1-44	ZW-356657	RING E 150SUP CMT			
1-45	ZG-336175	SP PULL PINCH ROLLER (T)			
1-46	ZG-321534	SP T2-3.2/0.29-12.5 T2-060			
1-47	ZW-336603	RING GRIP 285SUP ACP			
1-48	ZW-306464	PW31x070x050 STL CMT			
1-49	BL-B336202	ARM PINCH ROLLER (B) PART			
1-50	MP-336204	PINCH ROLLER (B)			
1-51	HZ-336205	GUIDE TAPE (B)			
1-52	ZS-608095	PAN20x05STL CMT			
1-53	ZG-336206	SP TORSION RETURN			
1-54	ZW-618884	N20STL CMT J			

When ordering parts, please quote Parts Number, Description and Model Number.

MOTOR BLOCK

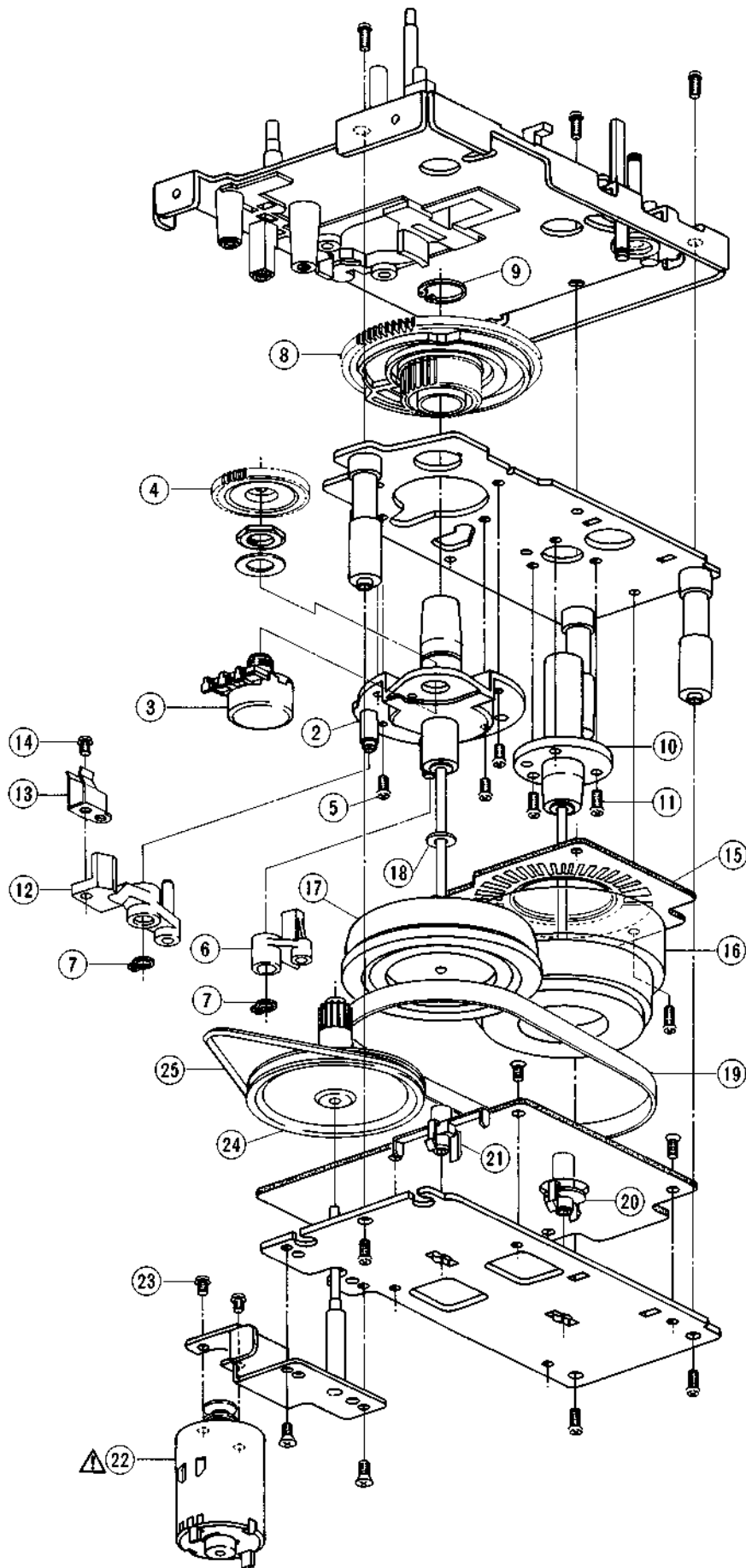

2. MOTOR BLOCK

REF. NO.	PARTS NO.	DESCRIPTION
2-1x	BM-M3104A010A	Δ MOTOR BLM-310
2-2	TC-B336004A	HOLDER CAPSTAN (C-1) PART
2-3	EV-337052	VR ROTARY 16L10XOR B103
2-4	MZ-336005	GEAR POTENTION
2-5	ZS-432843	PAN26x04STL CMT
2-6	BL-B336007	LEVER BRAKE CAM PART
2-7	ZW-336603	RING GRIP 285SUP ACP
2-8	MZ-336006	CAM WHEEL
2-9	ZW-336604	RING S839SUP ACP
2-10	TC-336002	HOLDER CAPSTAN (B)
2-11	ZS-479474	PAN26x05STL CMT
2-12	BL-B336009	LEVER EJECT CAM PART
2-13	ZG-336011	SP PLATE CAM LEVER
2-14	ZS-477876	PAN20x03STL CMT
2-15	EA-336012	PC FG
2-16	BF-B336024	FLYWHEEL (A) PART
2-17	MI-336025	FLYWHEEL (B)
2-18	ZW-309295	THRUST WASHER
2-19	MB-336026	BELT CAPSTAN
2-20	TC-336016	HOLDER THRUST (A)
2-21	TC-336027	HOLDER THRUST (B)
2-22	BM-B337064	Δ MOTOR OPERATION (PULLEY) PART
2-23	ZS-477876	PAN20x03STL CMT
2-24	MR-336019	PULLEY OPERATE
2-25	MB-336021	BELT OPERATION

3. PRE AMP P.C BOARD BLOCK

REF. NO.	PARTS NO.	DESCRIPTION
3-1	BA-T2033A210A	PC PRE AMP BLK GX-F91(U) (U,J,C,A)
3-2	BA-T2033A210B	PC PRE AMP BLK GX-F91(E) (E,B,S,V)
3-3	BA-T2033A210C	PC PRE AMP BLK GX-F91-P(U) (U,J,C,A)
3-4	BA-T2033A210D	PC PRE AMP BLK GX-F91-P(E) (E,B,S,V)

PRE AMP P.C BOARD

3-IC1	EI-337360	IC μ PC4082C
3-IC2,3	EI-306009	IC LM1111A
3-IC4	EI-336761	IC LA6458S
3-IC5,6	EI-306009	IC LM1111A
3-IC7	EI-336761	IC LA6458S
3-IC8	EI-337360	IC μ PC4082C
3-IC9	EI-336761	IC LA6458S
3-IC10	EI-314647	IC TA7179P
3-IC11	EI-336994	IC MS230L
3-IC12	EI-337360	IC μ PC4082C
3-TR1	ET-328437	TR 2SD1012-V F,G
3-TR2,3	ET-200505	TR 2SC2603 E,F
3-TR4	ET-337234	TR FET 2SK270 GR,BL
3-TR5	ET-328578	TR 2SC2320 E,F
3-TR6	ET-338180	TR 2SA798 E,F
3-TR7	ET-308954	TR 2SC1844 E,F
3-TR8	ET-338181	TR 2SC2909 R,S
3-TR9	ET-338244	TR 2SA1207 R,S
3-TR10	ET-341400	TR FET 2SK170 BL,GR
3-TR11	ET-639437	TR 2SC945L Q,P
3-TR12	ET-337967	TR 2SA990 E,F
3-TR13	ET-639437	TR 2SC945L Q,P
3-TR14to18	ET-200505	TR 2SC2603 E,F
3-TR19	ET-337111	TR FET 2SK146 GR,BL
3-TR20	ET-338350	TR 2SC2291 F,G
3-TR21	ET-338446	TR UPA75V P,F
3-TR22,23	ET-308954	TR 2SC1844 E,F
3-TR24	ET-338447	TR 2SA991 E,F
3-TR25	ET-341400	TR FET 2SK170 BL,GR
3-TR26	ET-337258	Δ TR 2SC1843 E,F
3-TR27	ET-308954	TR 2SC1844 E,F
3-TR28	ET-337967	Δ TR 2SA990 E,F
3-TR29	ET-337234	TR FET 2SK270 GR,BL
3-TR30	ET-328578	TR 2SC2320 E,F
3-TR31	ET-338180	TR 2SA798 E,F
3-TR32	ET-308954	TR 2SC1844 E,F
3-TR33	ET-338181	TR 2SC2909 R,S
3-TR34	ET-338244	TR 2SA1207 R,S
3-TR35	ET-341400	TR FET 2SK170 BL,GR
3-TR36	ET-337258	TR 2SC1843 E,F
3-TR37	ET-200505	TR 2SC2603 E,F
3-TR38	ET-639437	TR 2SC945L Q,P
3-TR39to42	ET-200505	TR 2SC2603 E,F
3-TR43	ET-639437	TR 2SC945L Q,P
3-TR44	ET-337235	TR FET 2SK170 BL,V
3-TR45	ET-200505	TR 2SC2603 E,F
3-TR46	ET-337235	TR FET 2SK170 BL,V
3-TR47to49	ET-200505	TR 2SC2603 E,F
3-TR50	ET-322598	Δ TR 2SB632K E,F
3-TR51	ET-310148	Δ TR 2SD612K E,F
3-TR52	ET-310148	Δ TR 2SD612K E,F
3-TR53	ET-322598	Δ TR 2SB632K E,F
3-TR54	ET-328578	TR 2SC2320 E,F
3-TR55	ET-309353	TR 2SC2274 E,F
3-TR56	ET-324134	TR 2SA984K E,F
3-TR57	ET-328440	Δ TR 2SD863-V8 E,F
3-TR58	ET-318237	Δ TR 2SB764 E,F
3-TR59	ET-554657	TR 2SA733A P,Q
3-TR60	ET-639437	TR 2SC945L Q,P
3-D1to4	ED-301911	D SILICON H DS448
3-D5	ED-308952	D GERMA V 1K34A-LR F07
3-D6to9	ED-301911	D SILICON H DS448
3-D10	ED-308952	D GERMA V 1K34A-LR F07
3-D11to13	ED-301911	D SILICON H DS448

REF. NO.	PARTS NO.	DESCRIPTION
3-D16	ED-306983	D ZENER H HZ12 C3
3-D17	ED-306983	D ZENER H HZ12 C3
3-D18to20	ED-301911	D SILICON H DS448
3-J1	EJ-337098	PIN J P 4P (U,J,C,A)
3-J1	EJ-337097	JACK PLATE (E,B,S,V)
3-SW1	ES-283072	SW SLIDE SSC22LP 2-02-02N (E,B,S,V)
3-SW2	ES-337311	SW PUSH SUN192A 2-04-02S
3-SW3	ES-337319	SW PUSH SUN192A 2-06-02N
3-SW4	ES-337319	SW PUSH SUN192A 2-06-02N
3-VR1	EV-341209	R S-FIX H CR19R 3P 0.50W 101
3-VR2	EV-483377	R S-FIX H SR19R 3P 0.15W 473
3-VR3	EV-330369	R S-FIX H SR19R 3P 0.15W 222
3-VR4	EV-341209	R S-FIX H CR19R 3P 0.50W 101
3-VR5	EV-330369	R S-FIX H SR19R 3P 0.15W 222
3-VR6	EV-301729	R S-FIX H CR19R 3P 0.50W 681
3-VR7	EV-483377	R S-FIX H SR19R 3P 0.15W 473
3-VR8	EV-341209	R S-FIX H CR19R 3P 0.50W 101
3-VR9	EV-312338	R S-FIX H CR19R 3P 0.50W 223
3-VR10	EV-623193	R S-FIX H CR19R 3P 0.50W 222
3-FL1	EO-336738	COIL TUN 1 102AK-004 19.8KHZ
3-FL2	ER-328491	FILTER DB D07-003K 100KHZ
3-FL3	ER-328490	FILTER DB D07-001K 19KHZ
3-FL4	ER-328491	FILTER DB D07-003K 100KHZ
3-FL5	EO-336738	COIL TUN 1 102AK-004 19.8KHZ
3-R9	ER-314630	R MF H 1/4W 1003F
3-R10	ER-311757	R MF H 1/4W 4701F
3-R17,18	ER-338221	R MF H F10 1/4W 152J
3-R19,20	ER-338222	R MF H F10 1/4W 390J
3-R24	ER-338221	R MF H F10 1/4W 152J
3-R32	ER-314630	R MF H 1/4W 1003F
3-R49	ER-314597	R MF H 1/4W 1302F
3-R50	ER-338108	R MF H 1/4W 4421F
3-R74	ER-314597	R MF H 1/4W 1302F
3-R87	ER-338183	R MF H 1/4W 104J
3-R88,89	ER-338184	R MF H 1/4W 152J
3-R90,91	ER-338223	R MF H F10 1/4W 100J
3-R95	ER-338186	R MF H 1/4W 471J
3-R96	ER-338224	R MF H F10 1/4W 392J
3-R97	ER-338187	R MF H 1/4W 153J
3-R100	ER-338187	R MF H 1/4W 153J
3-R101,102	ER-338225	R MF H F10 1/4W 331J
3-R103	ER-338109	R MF H 1/4W 4703F
3-R104	ER-301387	R MF H 1/4W 1002F
3-R110,111	ER-311763	R MF H 1/4W 2401F
3-R112	ER-311767	R MF H 1/4W 1201F
3-R114	ER-341398	R MF H 1/4W 6801F
3-R119,120	ER-338221	R MF H F10 1/4W 152J
3-R121,122	ER-338222	R MF H F10 1/4W 390J
3-R126	ER-338227	R MF H F10 1/4W 332J
3-R134	ER-338228	R MF H F10 1/4W 104J
3-R142	ER-314597	R MF H 1/4W 1302F
3-R156	ER-314597	R MF H 1/4W 1302F
3-R157	ER-338108	R MF H 1/4W 4421F
3-R202,203	ER-341399	R MF H 1/4W 1502F
3-R204	ER-310324	R MF H 1/4W 1001F
3-R205	ER-314626	R MF H 1/4W 1801F
3-R206	ER-310326	R MF H 1/4W 1002F
3-R207	ER-311773	R MF H 1/4W 3301F
3-R208,209	ER-341399	R MF H 1/4W 1502F
3-R241,242	ER-338498	R MF H F10 1/4W 102J
3-R243	ER-338184	R MF H 1/4W 152J
3-FR1,2	ER-328519	Δ R FUSE ERD2FC F10 1/4W 68R0G
3-FR3,4	ER-331188	Δ R FUSE ERD2FC F10 1/4W 8R2J
3-FR5	ER-318248	Δ R FUSE ERD2FC 1/4W 47R0G
3-C1	EC-483300	C MC V FM 5R0D 500DC (E,B,S,V)
3-C2	EC-337261	C EC V F05 NP NXA 1R0M 50DC (E,B,S,V)
3-C3	EC-341411	C MC V FE 7R00D 500DC
3-C4	EC-341391	C MC V FE 220J 500DC
3-C5	EC-338506	C COMP V AWS 103J 50DC
3-C6,7	EC-337294	C MMY V MMH63 105K 63DC
3-C11	EC-337002	C EC V F05 NP NXA 100M 16DC

When ordering parts, please quote Parts Number, Description and Model Number.

REF. NO.	PARTS NO.	DESCRIPTION
3-C12to14	EC-327097	C STY V F05 CQ09S 102J 50DC
3-C15	EC-338435	C PP V F03 FPS 3302G 100DC
3-C18	EC-337261	C EC V F05 NP NXA 1R0M 50DC
3-C27	EC-337002	C EC V F05 NP NXA 100M 16DC
3-C28to30	EC-327097	C STY V F05 CQ09S 102J 50DC
3-C31	EC-338435	C PP V F03 FPS 3302G 100DC
3-C34	EC-341407	C MMY V MMH63 224J 63DC
3-C42	EC-341395	C MC V FE 680J 500DC
3-C44	EC-341396	C MC V FE 150J 500DC
3-C45	EC-341396	C MC V FE 150J 500DC
3-C46	EC-341411	C MC V FE 7R00D 500DC
3-C47	EC-318313	C COMP V AWS 393J 50DC
3-C48	EC-341407	C MMY V MMH63 224J 63DC
3-C49	EC-341408	C COMP V AWS 3902G 50DC
3-C50	EC-341409	C COMP V AWS 6801G 50DC
3-C51	EC-337294	C MMY V MMH63 105K 63DC
3-C52,53	EC-338468	C PP V F03 FPS 6800G 100DC
3-C54	EC-338469	C PP V F03 FPS 1301G 100DC
3-C55	EC-341410	C COMP V AWS 8201G 50DC
3-C60	EC-342921	C STY V F05 CQ09S 101J 50DC
3-C61	EC-341411	C MC V FE 7R00D 500DC
3-C62	EC-341391	C MC V FE 220J 500DC
3-C63	EC-338506	C COMP V AWS 103J 50DC
3-C64	EC-337294	C MMY V MMH63 105K 63DC
3-C68	EC-337002	C EC V F05 NP NXA 100M 16DC
3-C69to71	EC-327097	C STY V F05 CQ09S 102J 50DC
3-C72	EC-338435	C PP V F03 FPS 3302G 100DC
3-C75	EC-341407	C MMY V MMH63 224J 63DC
3-C82to84	EC-327097	C STY V F05 CQ09S 102J 50DC
3-C85	EC-338435	C PP V F03 FPS 3302G 100DC
3-C88	EC-337261	C EC V F05 NP NXA 1R0M 50DC
3-C98	EC-308142	C STY V F05 CQ09S 471J 50DC
3-C99	EC-377212	C MC V VFM 470J 50DC
3-C100	EC-337002	C EC V F05 NP NXA 100M 16DC
3-C105	EC-306018	C STY V F05 CQ09S 681J 50DC
3-C110,111	EC-328862	C STY V F05 CQF09 152J 50DC
3-C112,113	EC-338094	C MMY V MMH63 104K 63DC
3-C118	EC-308142	C STY V F05 CQ09S 471J 50DC
3-C122	EC-637143	C MC V FM 7R00D 500DC
3-C137to140	EC-337294	C MMY V MMH63 105K 63DC
3-C143	EC-337002	C EC V F05 NP NXA 100M 16DC

PHONE JACK P.C BOARD

3-J1	EJ-336885	PHONE J 3P HLJ0607-023 6.3
3-J1	EJ-336886	PHONE J 3P HLJ0607-020 6.3 (P.BL)

4. SYS. CON. P.C BOARD BLOCK

REF. NO.	PARTS NO.	DESCRIPTION
4-1	BA-T2033A300A	PC SYS CON BLK GX-F91
SYS. CON. P.C BOARD		
4-IC1	EI-336761	IC LA6458S
4-IC2	EI-331275	IC TC9142P
4-IC3,4	EI-337008	IC LC7800
4-IC5	EI-337009	IC LC4049
4-IC6,7	EI-337013	IC LB1290
4-IC8	EI-337006	IC LM6402H-063
4-IC9	EI-336761	IC LA6458S
4-IC10	EI-330352	IC BA6109
4-TR1	ET-639437	TR 2SC945L Q,P
4-TR8,9	ET-200505	TR 2SC2603 E,F
4-TR10to14	ET-328868	TR 2SD1012-V G,H
4-TR15	ET-200505	TR 2SC2603 E,F
4-TR16,17	ET-336997	TR 2SB808-V G,H
4-TR19,20	ET-328868	TR 2SD1012-V G,H
4-TR21to25	ET-200505	TR 2SC2603 E,F
4-TR27	ET-554657	TR 2SA733A P,Q
4-TR29	ET-200505	TR 2SC2603 E,F
4-TR30	ET-554657	TR 2SA733A P,Q
4-TR31,32	ET-336997	TR 2SB808-V G,H
4-TR33	ET-200505	TR 2SC2603 E,F
4-D8	ED-200468	D SILICON V DS448-VB6
4-D10to12	ED-200468	D SILICON V DS448-VB6
4-D14	ED-200469	D SILICON H DS448 FA5 F10
4-D15	ED-337266	D ZENER H HZ9A-1
4-D16,17	ED-337268	D ZENER H HZ5A-1
4-D18	ED-200468	D SILICON V DS448-VB6
4-D26	ED-301911	D SILICON H DS448
4-J1	EJ-324276	DIN J TCS4680-01-111 P 8P
4-SR1	ER-337631	R COMP 01-0449
4-SR2	ER-337374	R COMP 01-0400
4-SR3	ER-337376	R COMP 01-0399
4-SR4	EC-338341	C COMP 05-0034
4-X1	EI-337123	OSC X'TAL 4.04727MHZ
4-X2	EC-337017	OSC CE CSB800A 0.8MHZ
4-R12	ER-658034	R OMF H FS 2W 221J
4-R124	ER-338235	R MF V 1/4W 1820F
4-R125	ER-338234	R MF V 1/4W 1331F
4-R126	ER-338233	R MF V 1/4W 2261F
4-R127	ER-338232	R MF V 1/4W 2871F
4-R128	ER-338231	R MF V 1/4W 5361F
4-FR1to3	ER-337871	Δ R FUSE ERQ14AJ 1/4W 330J

INTERMEDIATE P.C BOARD

4-D22to24	ED-200468	D SILICON V DS448-VB6
-----------	-----------	-----------------------

REC PAUSE P.C BOARD

4-TR40	ET-539133	TR 2SA733A P
4-TR41	ET-638504	TR 2SC945L P
4-D21,22	ED-200468	D SILICON V DS448-VB6

SYMBOL FOR DISTINATION

- U : UNIVERSAL AREA
- A : AMERICA
- B : UK
- C : CANADA
- E : EUROPE
- J : JAPAN
- S : AUSTRALIA
- V : GERMANY

5. TUNING P.C BOARD BLOCK

REF. NO.	PARTS NO.	DESCRIPTION	REF. NO.	PARTS NO.	DESCRIPTION
5-1	BA-T2033A250A	PC TUNING BLK GX-F91	5-R178	ER-338326	R MF H 1/4W 5602F
5-IC1	EI-337118	IC MB8841-649M	5-C9	EC-338434	C PP V F03 FPS 682J 100DC
5-IC2	EI-338238	IC μ PD4051	5-C12	EC-338579	C PP V F05 FPS 303J 100DC
5-IC3	EI-328690	IC AM1408N8	5-C14	EC-338431	C PP V F03 FPS 223J 100DC
5-IC4	EI-330475	IC M5L510P	5-C15	EC-338578	C PP V F03 FPS 102J 100DC
5-IC5	EI-317653	IC μ PD4066C	5-C16	EC-338430	C PP V F03 FPS 123J 100DC
5-IC6	EI-337370	IC LM13600N	5-C17	EC-341388	C MMY V MMH63 105J 63DC
5-IC7to11	EI-324255	IC TL082CP	5-C19	EC-341389	C MMY V MMH63 684J 63DC
5-IC12	EI-213390	IC NJM4558D	5-C20	EC-341388	C MMY V MMH63 105J 63DC
5-IC13to16	EI-336761	IC LA6458S	5-C21	EC-337002	C EC V F05 NP NXA 100M 16DC
5-TR1to4	ET-200985	TR 2SC2603 F,G	5-C22	EC-341391	C MC V FE 220J 500DC
5-TR5to10	ET-200558	TR 2SA1115 E,F	5-C23	EC-338506	C COMP V AWS 103J 50DC
5-TR11to13	ET-336997	TR 2SB808-V G,H	5-C26	EC-341393	C MC V FE 560J 500DC
5-TR14,15	ET-328868	TR 2SD1012-V G,H	5-C27	EC-338433	C PP V F03 FPS 273J 100DC
5-TR16	ET-338324	TR 2SD1012-V H	5-C28	EC-330310	C STY V F05 CQ09S 561J 50DC
5-TR17	ET-328868	TR 2SD1012-V G,H	5-C29	EC-341389	C MMY V MMH63 684J 63DC
5-TR18to23	ET-200985	TR 2SC2603 F,G	5-C42	EC-338434	C PP V F03 FPS 682J 100DC
5-TR24	ET-337234	TR FET 2SK270 GR,BL	5-C43	EC-321349	C MC V FM 150K 500DC
5-TR25,26	ET-337967	TR 2SA990 E,F	5-C44	EC-306018	C STY V F05 CQ09S 681J 50DC
5-TR27to29	ET-639437	TR 2SC945L Q,P	5-C46	EC-306018	C STY V F05 CQ09S 681J 50DC
5-TR30	ET-328868	TR 2SD1012-V G,H	5-C47	EC-321583	C PP V F10 PFH 102J 630DC
5-TR31,32	ET-200985	TR 2SC2603 F,G	5-C56	EC-443654	C MC V FM 150K 500DC
5-TR33	ET-337234	TR FET 2SK270 GR,BL	5-C60	EC-334064	C STY V F05 CQ09S 151J 50DC
5-TR34	ET-338350	TR 2SC2291 F,G	5-C64	EC-307684	C EC V F05 NP SM R47M 50DC
5-TR35	ET-338180	TR 2SA798 E,F	5-C66,67	EC-200948	C EC V F05 NP SM 1R0M 50DC
5-TR36	ET-308954	TR 2SC1844 E,F	5-C69	EC-341388	C MMY V MMH63 105J 63DC
5-TR37	ET-338181	TR 2SC2909 R,S	5-C71	EC-338449	C MC V FE 5R00D 500DC
5-TR38	ET-338244	TR 2SA1207 R,S	5-C72	EC-338451	C PP V F03 FPS 1001G 100DC
5-TR39	ET-639437	TR 2SC945L Q,P	5-C77	EC-341391	C MC V FE 220J 500DC
5-TR40,41	ET-200985	TR 2SC2603 F,G			
5-TR42	ET-307349	TR 2SD794 P,Q			
5-TR43to48	ET-200985	TR 2SC2603 F,G			
5-TR49	ET-307349	TR 2SD794 P,Q			
5-TR50,51	ET-200985	TR 2SC2603 F,G			
5-TR52to55	ET-308977	TR 2SC2274K F			
5-TR56to60	ET-200985	TR 2SC2603 F,G			
5-TR61,62	ET-328868	TR 2SD1012-V G,H			
5-TR63to68	ET-200985	TR 2SC2603 F,G			
5-TR69	ET-200558	TR 2SA1115 E,F			
5-TR70	ET-307349	TR 2SD794 P,Q			
5-TR71	ET-639437	TR 2SC945L Q,P			
5-D1to7	ED-301911	D SILICON H DS448			
5-D8	ED-337090	D VARACTOR KV-1236			
5-D9,10	ED-301911	D SILICON H DS448			
5-D11	ED-337090	D VARACTOR KV-1236			
5-D12,13	ED-301911	D SILICON H DS448			
5-D14	ED-338332	D ZENER H HZ4 A2			
5-D15to18	ED-301911	D SILICON H DS448			
5-D19	ED-338333	D ZENER H HZ5 B2			
5-D20,21	ED-301911	D SILICON H DS448			
5-D23to27	ED-301911	D SILICON H DS448			
5-D28	ED-331617	D ZENER H HZ6 A3			
5-D29,30	ED-301911	D SILICON H DS448			
5-VR1	EV-338570	R S-FIX V RVX0911 3P 503			
5-VR2,3	EV-341209	R S-FIX H CR19R 3P 0.50W 101			
5-VR4	EV-648753	R S-FIX H CR19R 3P 0.50W 473			
5-VR5	EV-321637	R S-FIX H D8 3P 104			
5-VR6	EV-315752	R S-FIX H D8 3P 204			
5-VR7	EV-314646	R S-FIX H D8 3P 202			
5-VR8	EV-321637	R S-FIX H D8 3P 104			
5-VR9	EV-315416	R S-FIX H D8 3P 103			
5-VR10	EV-315413	R S-FIX H D8 3P 503			
5-T1,2	EO-337343	COIL OSC 1 2325-267 100MHZ			
5-FL1	EO-315758	COIL TUN 1 100S-431 100KHZ			
5-FL2	ER-328491	FILTER DB D07-003K 100KHZ			
5-FL3	ER-337380	FILTER CE KMFC-1001S 3.580MHZ			
5-PH1	ET-337359	PHOTO SENSOR MCD-7213P			
5-RL1	EP-328529	RELAY LEAD LAB2NS 2NO 12V			
5-BT1	AX-336835	BATTERY 2/60DK			
5-TH1	ED-338477	THERMISTOR 112503-2			
5-VC1,2	EC-300034	C S-FIX H ECR-CA100H12 9.0-100			
5-FR1to5	ER-318647	R FUSE ERD2FC F10 1/4W 4R7J			
5-R177	ER-338325	R MF H 1/4W 4302F			

When ordering parts, please quote Parts Number, Description and Model Number.

DOOR BLOCK

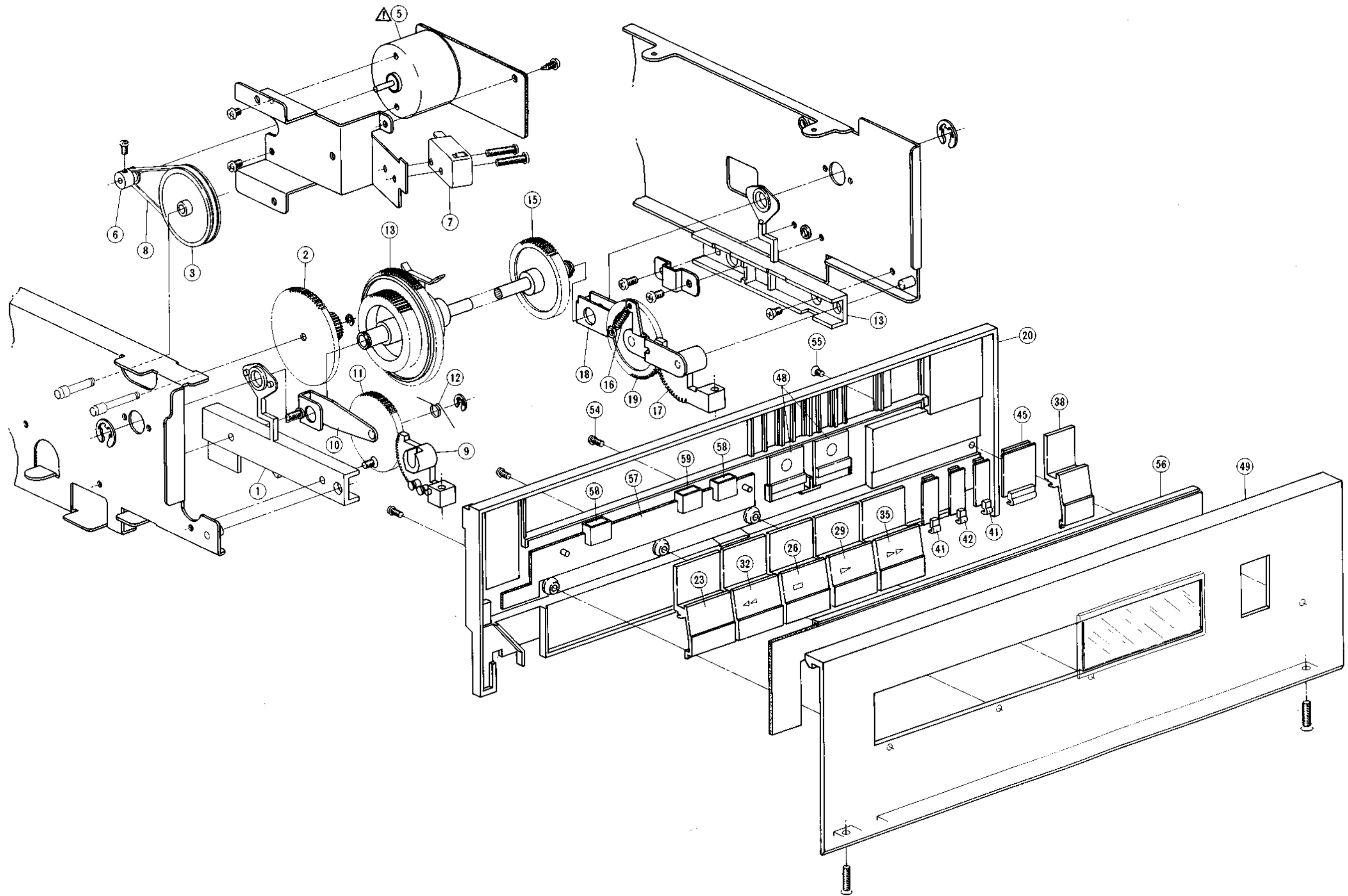

6. POWER P.C BOARD BLOCK

REF. NO.	PARTS NO.	DESCRIPTION
6-1	BA-T2033A310A	PC POWER BLK GX-F91(U)
6-2	BA-T2033A310B	PC POWER BLK GX-F91(J)
6-3	BA-T2033A310C	PC POWER BLK GX-F91(C)
6-4	BA-T2033A310D	PC POWER BLK GX-F91(E)(E,V)
6-5	BA-T2033A310E	PC POWER BLK GX-F91(B)(B,S)
6-6	BA-T2033A310F	PC POWER BLK GX-F91(A)
6-IC1	EI-337329	IC TA78L007AP
6-TR1	ET-200986	TR 2SD863-V8 F
6-TR2	ET-322598	Δ TR 2SB632K E,F
6-TR3	ET-639437	TR 2SC945L Q,P
6-TR4	ET-322598	Δ TR 2SB632K E,F
6-TR5	ET-639437	TR 2SC945L Q,P
6-TR6	ET-322598	Δ TR 2SB632K E,F
6-TR7	ET-639437	TR 2SC945L Q,P
6-TR8	ET-337760	Δ TR 2SA984K F
6-TR9	ET-639437	TR 2SC945L Q,P
6-D1to4	ED-306109	Δ D SILICON W03B 100/1.0A
6-D5	ED-338013	D ZENER V HZ24-3S1
6-D6	ED-338540	D ZENER V HZ20-2S1
6-D7	ED-330987	Δ D SILICON RB152 200/1.5A
6-D8	ED-338083	D ZENER V HZ9C-3S1
6-D9	ED-338082	D ZENER V HZ5C-1S1
6-D10	ED-302295	D ZENER H HZ7 C3
6-D11to14	ED-338322	Δ D SILICON 10DF1 100/1.0A
6-D15	ED-330622	D SILICON 1SR35-100VL 100/1.0A
6-D16	ED-338318	D ZENER V HZ7C-3S1
6-D17	ED-200468	D SILICON V DS448-VB6
6-SW1	ES-312234	Δ SW PUSH SDL-1P 01-1 E (U,E,B,S,V)
6-SW1	ES-312235	Δ SW PUSH SDL-1P 01-1 J (J) (C,A)
6-SW1	ES-312238	Δ SW PUSH SDL-1P 01-1 UC (C,A)
6-VS1	EJ-283140	Δ SOCKET SELECTER X-I7238 6P(U)
6-R1	ER-338319	Δ R CB H FS RDS 1/2W 222J
6-C1	EC-338592	Δ C MMY V ECQEW 104J 250AC(U,B,S,V)
6-C1	EC-338400	Δ C MMY V ECQ-E 473M 125DC(J)
6-C1	EC-338419	Δ C MMY V ECQUE 473JM 125AC(C,A)
6-C2,3	EC-201758	C EC V CUT USM 332M 25.0DC
6-C18	ER-201749	C EC V CUT USM 102M 16DC

SYMBOL FOR DISTINATION

U : UNIVERSAL AREA
A : AMERICA
B : UK
C : CANADA
E : EUROPE
J : JAPAN
S : AUSTRALIA
V : GERMANY

7. METER DRIVE P.C BOARD BLOCK

REF. NO.	PARTS NO.	DESCRIPTION
7-1	BA-T2033A190A	PC METER DRIVE BLK GX-F91
7-IC1	EI-304164	IC μPD4011C
7-IC2	EI-319555	IC μPD4049C
7-IC3,4	EI-336761	IC LA6458S
7-IC5	EI-337126	IC TA7332P
7-IC6,7	EI-315379	IC TCS066BP
7-TR1	ET-554657	TR 2SA733A P,Q
7-TR2	ET-639437	TR 2SC945L Q,P
7-TR3,4	ET-554657	TR 2SA733A P,Q
7-TR5to11	ET-639437	TR 2SC945L Q,P
7-TR12	ET-554657	TR 2SA733A P,Q
7-TR13to21	ET-639437	TR 2SC945L Q,P
7-D1to5	ED-301911	D SILICON H DS448
7-D6,7	ED-308953	D GERMA H 1K34A-LH SNP
7-D8to31	ED-301911	D SILICON H DS448
7-D32	ED-331198	D ZENER H HZ3 A1
7-D33to35	ED-301911	D SILICON H DS448
7-D36	ED-301911	D SILICON H DS448
7-VR1	EV-572422	R S-FIX V V8K1-1 3P 203
7-VR2	EV-522663	R S-FIX V V8K1-1 3P 104
7-R27	ER-338593	R OMF H SNP FS 2W 821J
7-C16,17	EC-314986	C EC V CUT NP LR R47M 50DC

8. METER P.C BOARD BLOCK

REF. NO.	PARTS NO.	DESCRIPTION
8-IC1	EI-325755	IC LC7550
8-D1to3	ED-200469	D SILICON H DS448 FA5 F10
8-D4	ED-312101	D LED SG238D GRN
8-D5,6	ED-337330	D LED SY438D YLW
8-D7	ED-312108	D LED SR538D RED
8-D8to11	ED-200469	D SILICON H DS448 FA5 F10
8-IN1	EM-337125	IND FL BG-107Z GRAPH

9. MOTOR P.C BOARD BLOCK

REF. NO.	PARTS NO.	DESCRIPTION
9-IC1	EI-201940	IC NJM4558S
9-IC3,4	EI-337568	HOLE ELEMENT DHD-H070
9-TR1	ET-337011	TR 2SC2274K D,E
9-TR2	ET-337012	TR 2SA984K D,E
9-TR3	ET-337011	TR 2SC2274K D,E
9-TR4	ET-337012	TR 2SA984K D,E
9-D5	ED-338561	D ZENER H HZ2 F10 B2
9-VR1,2	EV-464253	R S-FIX V V8K1-1 3P 202

10. INDICATOR P.C BOARD BLOCK

REF. NO.	PARTS NO.	DESCRIPTION
10-D1to6	ED-337091	D LED LT9200N GRN
10-D7	ED-337093	D LED GL-9NG4 GRN
10-D8to15	ED-337848	D LED GL-9HY84 YLW
10-D16	ED-328791	D LED GL-9PR4 RED
10-D17	ED-337093	D LED GL-9NG4 GRN
10-D21to29	ED-200212	D SILICON H DS448Fx2 F07

11. DOOR OPEN P.C BOARD BLOCK

REF. NO.	PARTS NO.	DESCRIPTION
11-TR1	ET-200505	TR 2SC2603 E,F
11-TR2,3	ET-328868	TR 2SD1012-V G,H
11-TR4,5	ET-324134	TR 2SA984K E,F
11-D1,2	ED-200468	D SILICON V DS448-VB6
11-L1,2	EO-669273	COIL FIX 2 FL5R200 18μH

12. MONITOR P.C BOARD BLOCK

REF. NO.	PARTS NO.	DESCRIPTION
12-D1	ED-332243	D LED SLP-171D RED
12-D2	ED-336786	D LED SLP-271D GRN
12-SW1	ES-309311	SW TACT KEG10904

13. DOOR BLOCK

REF. NO.	PARTS NO.	DESCRIPTION
CHASSIS (L) BLOCK		
13-1	MZ-332667	GUIDE (L)
13-2	TC-336506	GEAR SHIFT DOWN
13-3	TC-332657	GEAR PULLEY
13-4	ZW-270088	RING E 190SUP CMT
13-5	BM-337351	Δ MOTOR M32E-1
13-6	MR-336511	PULLEY MOTOR
13-7	ES-691457	SW MICRO VU-SR
13-8	MB-666123	BELT DRIVE
HINGE (L) BLOCK		
13-9	BL-B332649	LEVER HINGE (L) PART
13-10	BL-B332654	LEVER MAIN PART
13-11	TC-332661	GEAR IDLER (L)
13-12	ZG-336524	SP TORSION MASS BALANCE (B)
CLUTCH BLOCK		
13-13	TC-T2033A040A	CLUTCH BLK GX-F91
CHASSIS (R) BLOCK		
13-14	TC-332666	GUIDE (R)
HINGE (R) BLOCK		
13-15	BZ-T2033A070A	HINGE (R) BLK GX-F91
13-16	ZG-312961	SP T1-3.2/0.45-14.0 T1-076
13-17	BL-B332650	LEVER HINGE (R) PART
13-18	BL-B332654X2	LEVER MAIN PART (2)
13-19	TC-342413	GEAR IDLER (R)
DOOR BLOCK		
13-20	SE-332689A	ESCUTCHEON DOOR
13-21x	SE-332689B	ESCUTCHEON DOOR-P
13-22x	SE-332689C	ESCUTCHEON DOOR-B
13-23	SK-332694A	KNOB OPERATE (A-1)
13-24x	SK-332694B	KNOB OPERATE (A-1)-P
13-25x	SK-332694C	KNOB OPERATE (A-1)-B
13-26	SK-332694D	KNOB OPERATE (A-2)
13-27x	SK-332694E	KNOB OPERATE (A-2)-P
13-28x	SK-332694F	KNOB OPERATE (A-2)-B
13-29	SK-B332695A	KNOB OPERATE (A-3) PART
13-30x	SK-B332695B	KNOB OPERATE (A-3)-P PART
13-31x	SK-B332695C	KNOB OPERATE (A-3)-B PART
13-32	SK-B332696A	KNOB OPERATE (A-4) PART
13-33x	SK-B332696B	KNOB OPERATE (A-4)-P PART
13-34x	SK-B332696C	KNOB OPERATE (A-4)-B PART
13-35	SK-B332697A	KNOB OPERATE (A-5) PART
13-36x	SK-B332697B	KNOB OPERATE (A-5)-P PART
13-37x	SK-B332697C	KNOB OPERATE (A-5)-B PART
13-38	SK-332699A	KNOB OPERATE (B)
13-39x	SK-332699B	KNOB OPERATE (B)-P
13-40x	SK-332699C	KNOB OPERATE (B)-B
13-41	SK-B332701A	KNOB OPERATE (C-1) PART
13-42	SK-B332701B	KNOB OPERATE (C-2) PART
13-43x	SK-B332701C	KNOB OPERATE (C-2)-P PART
13-44x	SK-B332701D	KNOB OPERATE (C-2)-B PART
13-45	SK-B332704A	KNOB OPERATE (D) PART
13-46x	SK-B332704B	KNOB OPERATE (D)-P PART
13-47x	SK-B332704C	KNOB OPERATE (D)-B PART
13-48	ED-337010	D LED SLF-201C GRN
13-49	BD-B332688A	PANEL DOOR PART
13-50x	BD-B332688B	PANEL DOOR-P PART
13-51x	BD-B332688C	PANEL DOOR-B PART
13-52x	SZ-330911	CUCHEON RUBBER
13-53x	SZ-330911B	CUCHEON RUBBER (BL)
13-54	ZS-356681	PAN23x05STL NI3
13-55	ZS-312963	CTS23x04STL NI3

13-56 BA-T2033A280A PC OPERATE BLK GX-F91

LED P.C BOARD BLOCK
 13-57 BA-T2033A290A PC LED BLK GX-F91
 13-58 ED-337101 D LED LT9200H YLW (D1.2)
 13-59 ED-337091 D LED LT9200N GRN (D3)

SYMBOL FOR COLOR VARIATION

NONE - SILVER
 P - PEARL SHADOW
 B or BL - BLACK

ASSEMBLY BLOCK

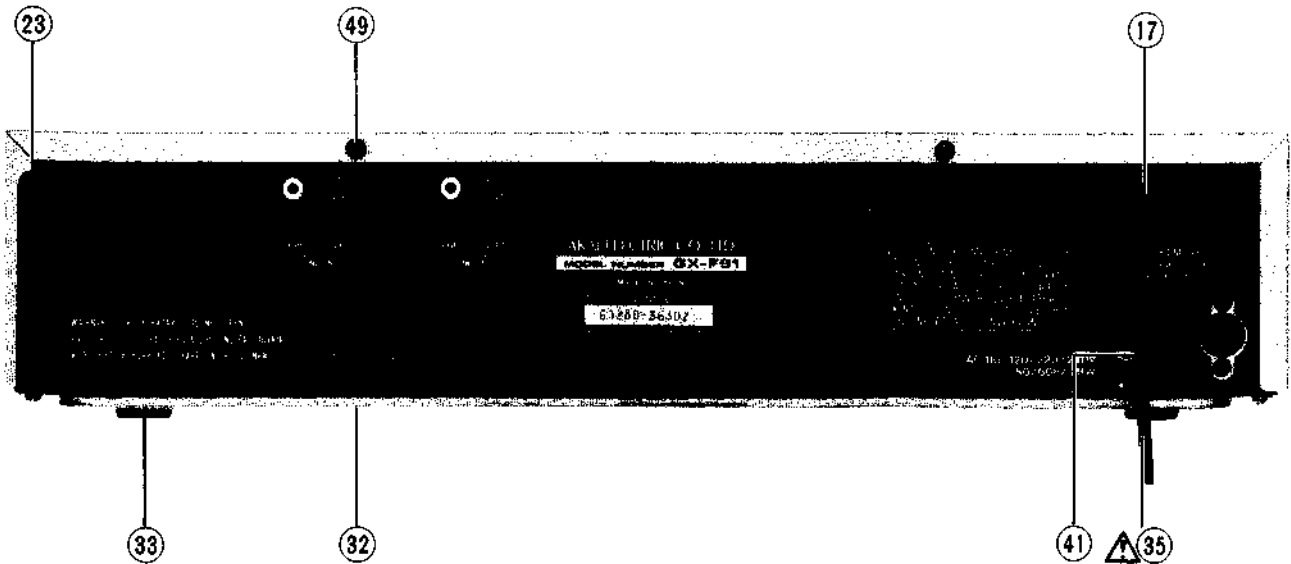
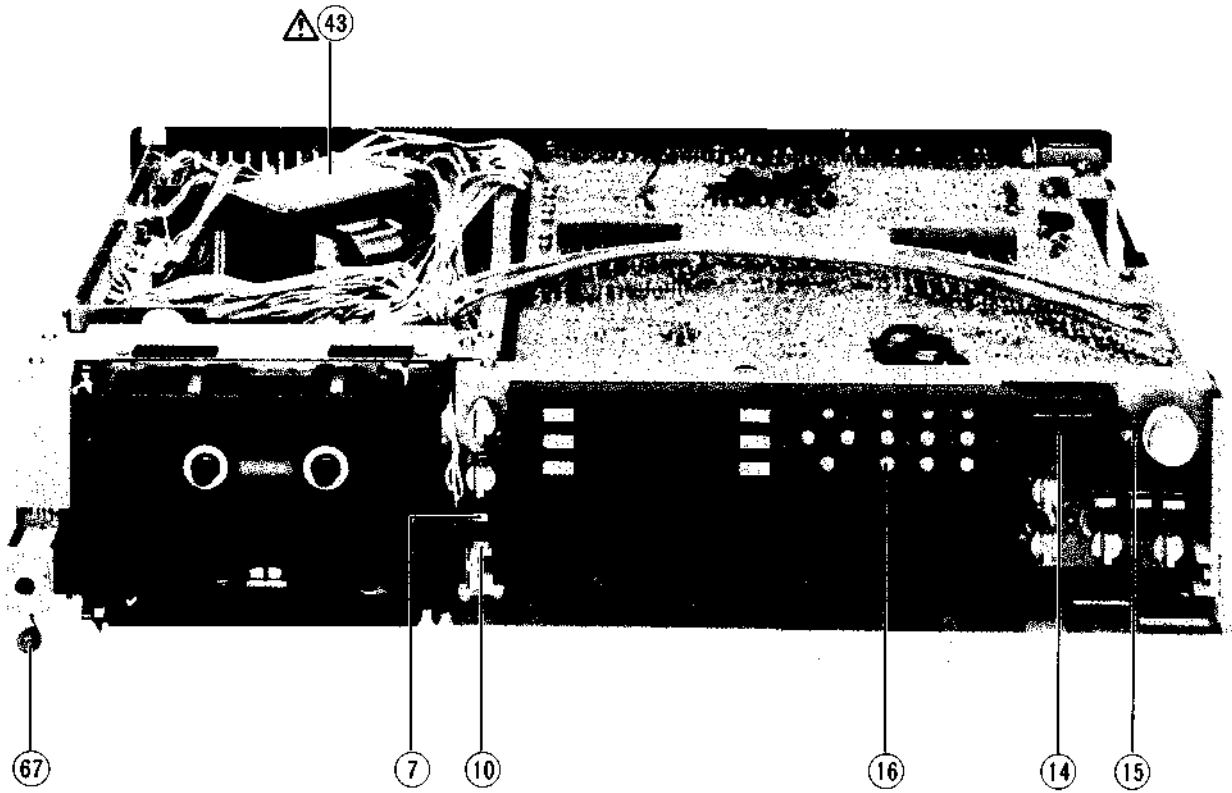

14. ASSEMBLY BLOCK

REF. NO.	PARTS NO.	DESCRIPTION
INPUT P.C BOARD BLOCK		
14-1x	EV-337312	VR DETENT 01P20x0A M503 N503 (VR1)
14-2x	EV-337310	VR DETENT 00P20x0A A503 (VR2)
MODE P.C BOARD BLOCK		
14-3x	ES-337232	SW ROTARY SBM1023N 2-02-03N (SW1,2)
COUNTER RESET P.C BOARD BLOCK		
14-4	ES-336780	SW TACT KHH10902 (SW1,2)
OUTPUT P.C BOARD BLOCK		
14-5x	EV-337314	VR ROTARY 12P20x0C A203 (VR1)
14-6x	EV-337313	VR DETENT 00P20x0B B502 (VR2)
HOLDER COUNTER KNOB BLOCK		
14-7	SK-332645A	KNOB COUNTER (A)
14-8x	SK-332645B	KNOB COUNTER (A)-P
14-9x	SK-332645C	KNOB COUNTER (A)-B
14-10	SK-332646A	KNOB COUNTER (B)
14-11x	SK-332646B	KNOB COUNTER (B)-P
14-12x	SK-332646C	KNOB COUNTER (B)-B
VOLUME BLOCK		
14-13x	EV-337106	VR ROTARY 16L10x0T B103 (VR902)
HOLDER METER BLOCK		
14-14	SK-332685	KNOB MONITOR
14-15	ZG-313152	SP C-2.5/0.2-10.0 C-002
14-16	ES-337349	SW ASSIST T2033D4710 RUBBER SHEET

ASSEMBLY BLOCK

14-17	SP-332677A	PANEL REAR GX-F91(U) AS
14-18x	SP-332677B	PANEL REAR GX-F91(J) AS
14-19x	SP-332677C	PANEL REAR GX-F91(C) AS
14-20x	SP-332677D	PANEL REAR GX-F91(A) AS
14-21x	SP-332677E	PANEL REAR GX-F91(E,V) AS
14-22x	SP-332677F	PANEL REAR GX-F91(B,S) AS
14-23	ZS-447761	T2BR30x06STL BNI
14-24x	ZG-313068	SP T1-6.3/0.5-16.0 T1-180
14-25x	ZG-312924	SP T1-3.2/0.2-12.5 T1-041
14-26x	ZG-313070	SP T1-6.3/0.5-10.0 T1-182
14-27x	TC-336512	COVER HINGE (R)
14-28x	TC-336513	COVER HINGE (L)
14-29x	ZG-313031	SP T1-5.0/0.32-28.0 T1-144
14-30x	ZW-312121	RV NYL26x042 BL
14-31x	ZW-698308	RV NYL30x055 BL
14-32	SP-332678	COVER BOTTOM
14-33	SA-305646	RUBBER FOOT (A) (BLACK)
14-34x	ZS-494842	T2BID30x08STL CMT PW080
14-35	EW-306428	Δ AC CORD 2 CORES KP-205A VFF J (U)
14-36x	EW-306427	Δ AC CORD 2 CORES KP-211, VFF J (J)
14-37x	EW-305691	Δ AC CORD 2 CORES KP-8, SPT-1 UC (C,A)
14-38x	EW-313882	Δ AC CORD 2 CORES KP-419C, LTCE-2F E (E,V)
14-39x	EW-313884	Δ AC CORD 2 CORES GTBS-2F 24/0.20x2 B (B)
14-40x	EW-201515	Δ AC CORD 2 CORES KP-560, LTSA-2FS (S)
14-41	SZ-631945	STRAIN RELIEF SR-4N-4 (EXCEPT B)
14-42x	EJ-692908	STRAIN RELIEF SR-5N-4 (B)
14-43	BT-337113	Δ TRANS POWER T2033-U
14-44x	BT-337114	Δ TRANS POWER T2033-J
14-45x	BT-337115	Δ TRANS POWER T2033-A.C
14-46x	BT-337116	Δ TRANS POWER T2033-E.V
14-47x	BT-337117	Δ TRANS POWER T2033-B.S
14-48x	ZS-301398	ST BID40x08STL CMT

REF. NO.	PARTS NO.	DESCRIPTION
14-49	ZS-447840	T2BR30x08STL CMT
14-50x	ZS-463353	T2BR30x08STL BNI (P,BL)
14-51x	EF-306949	Δ FUSE TSC A 250V 1.25A (F2,3) (U,J)
14-52x	EF-327103	Δ FUSE TSC A 250V 0.50A (F4) (U,J)
14-53x	EF-306949	Δ FUSE TSC A 250V 1.25A (F5,6) (U,J)
14-54x	EF-327103	Δ FUSE TSC A 250V 0.50A (F7) (U,J)
14-55x	EF-308933	Δ FUSE TSC A 250V 0.20A (F8,9) (J)
14-56x	EF-309392	Δ FUSE TSC 125V 1.25A (F2,3) (C,A)
14-57x	EF-309390	Δ FUSE TSC 125V 0.50A(F4) (C,A)
14-58x	ZS-300519	Δ ST PAN40x08STL CMT (F5,6) (C,A)
14-59x	EF-309390	Δ FUSE TSC 125V 0.50A(F7) (C,A)
14-60x	EF-315334	Δ FUSE TSC 125V 0.25A (F8,9) (C,A)
14-61x	EF-695766	Δ FUSE SEMKO T 250V 0.31A (F1) (E,B,S,V)
14-62x	EF-602550	Δ FUSE SEMKO T 250V 1.25A (F2,3) (E,B,S,V)
14-63x	EF-593706	Δ FUSE SEMKO T 250V 0.50A (F4) (E,B,S,V)
14-64x	EF-602550	Δ FUSE SEMKO T 250V 1.25A (F5,6) (E,B,S,V)
14-65x	EF-593706	Δ FUSE SEMKO T 250V 0.50A (F7) (E,B,S,V)
14-66x	EF-300588	Δ FUSE EAWK T 250V 0.20A (F8,9) (E,B,S,V)
14-67	EL-337053	PL CORD 16.0V 80MA 400/400

SYMBOL FOR DISTINATION

U	: UNIVERSAL AREA
A	: AMERICA
B	: UK
C	: CANADA
E	: EUROPE
J	: JAPAN
S	: AUSTRALIA
V	: GERMANY

SYMBOL FOR COLOR VARIATION

NONE	- SILVER
P	- PEARL SHADOW
B or BL	- BLACK

FINAL ASSEMBLY BLOCK

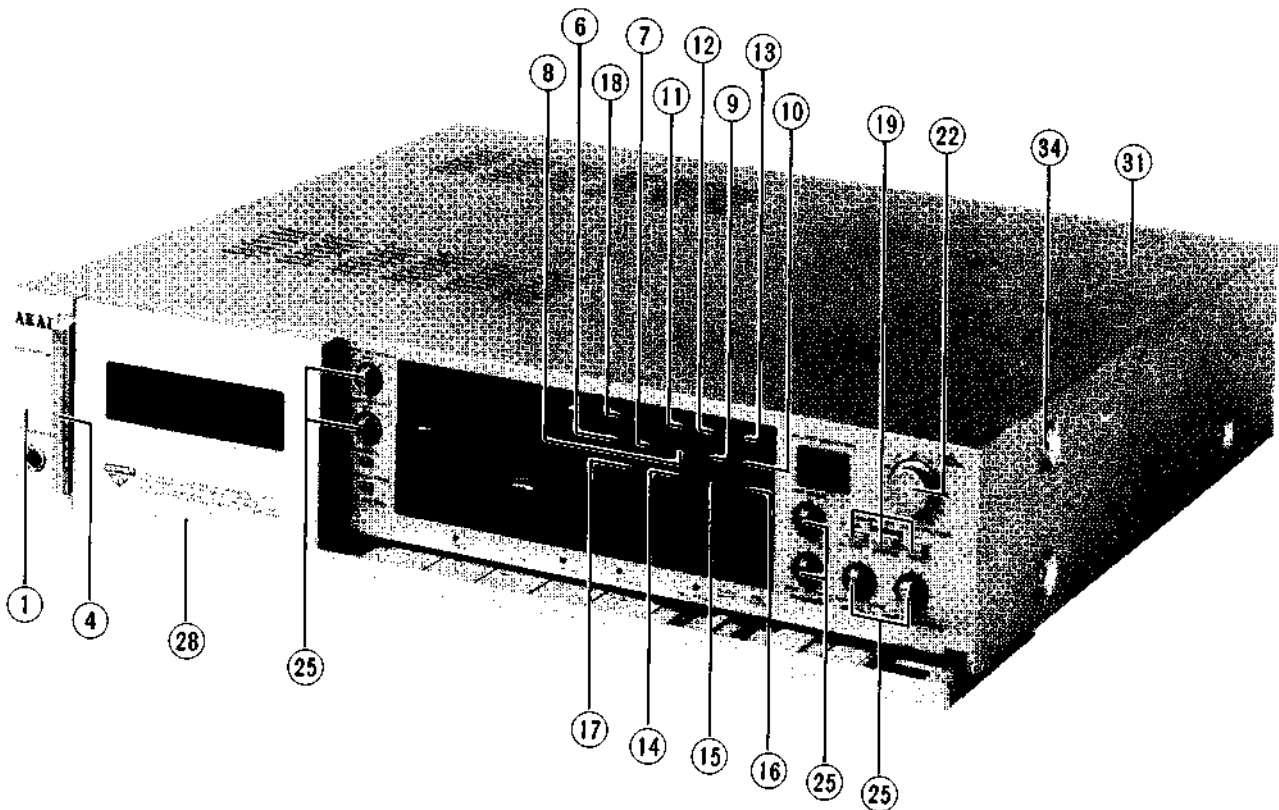

15. FINAL ASSEMBLY BLOCK

REF. NO.	PARTS NO.	DESCRIPTION
----------	-----------	-------------

PANEL FRONT BLOCK

15-1	BD-B332683A	PANEL FRONT PART
15-2x	BD-B332683B	PANEL FRONT-P PART
15-3x	BD-B332683C	PANEL FRONT-B PART
15-4	SK-336251	KNOB POWER
15-5x	SK-336252	KNOB SPACER
15-6	SK-332640A	KNOB (C-1)
15-7	SK-332640B	KNOB (C-2)
15-8	SK-332640C	KNOB (C-3)
15-9	SK-332640D	KNOB (C-4)
15-10	SK-332640E	KNOB (C-5)
15-11	SK-332640F	KNOB (C-6)
15-12	SK-332640G	KNOB (C-7)
15-13	SK-332640H	KNOB (C-8)
15-14	SK-332640J	KNOB (C-9)
15-15	SK-332640K	KNOB (C-10)
15-16	SK-332640L	KNOB (C-11)
15-17	SK-332641A	KNOB (D-1)
15-18	SK-332641B	KNOB (D-2)

FINAL ASSEMBLY BLOCK

15-19	SK-336530A	KNOB DOLBY
15-20x	SK-336530B	KNOB DOLBY-P (P)
15-21x	SK-336530C	KNOB DOLBY-B (BL)
15-22	SK-332706A	KNOB (A)
15-23x	SK-332706B	KNOB (A)-P (P)
15-24x	SK-332706C	KNOB (A)-B (BL)
15-25	SK-332707A	KNOB (B)
15-26x	SK-332707B	KNOB (B)-P (P)

REF. NO.	PARTS NO.	DESCRIPTION
----------	-----------	-------------

15-27x	SK-332707C	KNOB (B)-B (BL)
15-28	BD-B332636A	LID PANEL PART
15-29x	BD-B332636B	LID PANEL-P PART (P)
15-30x	BD-B332636C	LID PANEL-B PART (BL)
15-31	SP-332684A	COVER UPPER
15-32x	SP-332684B	COVER UPPER-P (P)
15-33x	SP-332684C	COVER UPPER-B (BL)
15-34	ZS-341963	XST BID40x06STL N13
15-35x	ZS-341964	XST BID40x06STL BNI (P,BL)
15-36x	ZW-305013	RV POP32 (A)

SYMBOL FOR COLOR VARIATION

NONE - SILVER
P - PEARL SHADOW
B or BL - BLACK

INDEX

PARTS NO.	REF. NO.	PARTS NO.	REF. NO.	PARTS NO.	REF. NO.	PARTS NO.	REF. NO.
AX-336835	5-BT1	EC-337002	3-C68	ED-301911	5-D23to27	EI-336761	5-IC13to16
BA-T2033A190A	7-1	EC-337002	5-C21	ED-301911	5-D29,30	EI-336761	7-IC3,4
BA-T2033A210A	3-1	EC-337017	4-X2	ED-301911	7-D33to35	EI-336994	3-IC11
BA-T2033A210B	3-2	EC-337261	3-C88	ED-301911	7-D1to5	EI-337006	4-IC8
BA-T2033A210C	3-3	EC-337261	3-C2	ED-301911	7-D8to31	EI-337008	4-IC3,4
BA-T2033A210D	3-4	EC-337261	3-C18	ED-301911	7-D36	EI-337009	4-IC5
BA-T2033A250A	5-1	EC-337294	3-C137to140	ED-302295	6-D10	EI-337013	4-IC6,7
BA-T2033A280A	13-56	EC-337294	3-C6,7	ED-306109	6-D1to4	EI-337118	5-IC1
BA-T2033A290A	13-57	EC-337294	3-C51	ED-306983	3-D16	EI-337123	4-X1
BA-T2033A300A	4-1	EC-337294	3-C64	ED-306983	3-D17	EI-337126	7-IC5
BA-T2033A310A	6-1	EC-338094	3-C112,113	ED-308952	3-D5	EI-337329	6-IC1
BA-T2033A310B	6-2	EC-338341	4-SR4	ED-308952	3-D10	EI-337360	3-IC1
BA-T2033A310C	6-3	EC-338400	6-C1	ED-308953	7-D6,7	EI-337360	3-IC8
BA-T2033A310D	6-4	EC-338419	6-C1	ED-312101	8-D4	EI-337360	3-IC12
BA-T2033A310E	6-5	EC-338430	5-C16	ED-312108	8-D7	EI-337370	5-IC6
BA-T2033A310F	6-6	EC-338431	5-C14	ED-328791	10-D16	EI-337568	9-IC3,4
BD-B332636A	15-28	EC-338433	5-C27	ED-330622	6-D15	EI-338238	5-IC2
BD-B332636B	15-29x	EC-338434	5-C9	ED-330987	6-D7	EJ-283140	6-VS1
BD-B332636C	15-30x	EC-338434	5-C42	ED-331198	7-D32	EJ-324276	4-J1
BD-B332683A	15-1	EC-338435	3-C72	ED-331617	5-D28	EJ-336885	3-J1
BD-B332683B	15-2x	EC-338435	3-C85	ED-332243	12-D1	EJ-336886	3-J1
BD-B332683C	15-3x	EC-338435	3-C15	ED-336786	12-D2	EJ-337097	3-J1
BD-B332688A	13-49	EC-338435	3-C31	ED-337010	1-26	EJ-337098	3-J1
BD-B332688B	13-50x	EC-338449	5-C71	ED-337010	13-48	EJ-692908	14-42x
BD-B332688C	13-51x	EC-338451	5-C72	ED-337090	5-D8	EL-337053	14-67
BD-B336162A	1-63	EC-338468	3-C52,53	ED-337090	5-D11	EM-337125	8-IN1
BF-B336024	2-16	EC-338469	3-C54	ED-337091	10-D1to6	EO-315758	5-FL1
BH-T2033A360A	1-1x	EC-338506	3-C5	ED-337091	13-59	EO-336738	3-FL1
BL-B332649	13-9	EC-338506	3-C63	ED-337093	10-D17	EO-336738	3-FL5
BL-B332650	13-17	EC-338506	5-C23	ED-337093	10-D7	EO-337343	5-T1,2
BL-B332654	13-10	EC-338578	5-C15	ED-337101	13-58	EO-669273	1-22x
BL-B332654X2	13-18	EC-338579	5-C12	ED-337266	4-D15	EO-669273	11-L1,2
BL-B336007	2-6	EC-338592	6-C1	ED-337268	4-D16,17	EP-328529	5-RL1
BL-B336009	2-12	EC-341388	5-C17	ED-337330	8-D5,6	ER-201749	6-C18
BL-B336150	1-41	EC-341388	5-C20	ED-337848	10-D8to15	ER-301387	3-R104
BL-B336196	1-37	EC-341388	5-C69	ED-338013	6-D5	ER-310324	3-R204
BL-B336202	1-49	EC-341389	5-C19	ED-338082	6-D9	ER-310326	3-R206
BL-T2030A160A	1-23	EC-341389	5-C29	ED-338083	6-D8	ER-311757	3-R10
BL-T2030A170A	1-25	EC-341391	3-C4	ED-338318	6-D16	ER-311763	3-R110,111
BM-B336989	1-21	EC-341391	3-C62	ED-338322	6-D11to14	ER-311767	3-R112
BM-B337064	2-22	EC-341391	5-C22	ED-338332	5-D14	ER-311773	3-R207
BM-M3104A010A	2-1x	EC-341391	5-C77	ED-338333	5-D19	ER-314597	3-R49
BM-T2030A120A	1-20	EC-341493	5-C26	ED-338477	5-TH1	ER-314597	3-R74
BM-337351	13-5	EC-341395	3-C42	ED-338540	6-D6	ER-314597	3-R142
BR-336606	1-31	EC-341396	3-C44	ED-338561	9-D5	ER-314597	3-R156
BR-342719	1-32	EC-341396	3-C45	EF-300588	14-66x	ER-314626	3-R205
BT-337113	14-43	EC-341407	3-C75	EF-306949	14-51x	ER-314630	3-R9
BT-337114	14-44x	EC-341407	3-C34	EF-306949	14-53x	ER-314630	3-R32
BT-337115	14-45x	EC-341407	3-C48	EF-308933	14-55x	ER-318248	3-FR5
BT-337116	14-46x	EC-341408	3-C49	EF-309390	14-57x	ER-318647	5-FR1to5
BT-337117	14-47x	EC-341409	3-C50	EF-309390	14-59x	ER-328490	3-FL3
BZ-T2030A110A	1-16	EC-341410	3-C55	EF-309392	14-56x	ER-328491	3-FL2
BZ-T2033A070A	13-15	EC-341411	3-C3	EF-315334	14-60x	ER-328491	3-FL4
BZ-T2033A340A	1-27x	EC-341411	3-C46	EF-327103	14-54x	ER-328491	5-FL2
EA-336012	2-15	EC-341411	3-C61	EF-327103	14-52x	ER-328519	3-FR1,2
EC-200948	5-C66,67	EC-377212	3-C99	EF-593706	14-63x	ER-331188	3-FR3,4
EC-201758	6-C2,3	EC-443654	5-C56	EF-593706	14-65x	ER-337374	4-SR2
EC-300034	5-VC1,2	EC-483300	3-C1	EF-602550	14-62x	ER-337376	4-SR3
EC-306018	3-C105	EC-637143	3-C122	EF-602550	14-64x	ER-337380	5-FL3
EC-306018	5-C44	ED-200212	10-D21to29	EF-695766	14-61x	ER-337631	4-SR1
EC-306018	5-C46	ED-200468	4-D8	EI-201940	9-IC1	ER-337871	4-FR1to3
EC-307684	5-C64	ED-200468	4-D10to12	EI-213390	5-IC12	ER-338108	3-R50
EC-308142	3-C98	ED-200468	4-D18	EI-304164	7-IC1	ER-338108	3-R157
EC-308142	3-C118	ED-200468	4-D22to24	EI-306009	3-IC2,3	ER-338109	3-R103
EC-314986	7-C16,17	ED-200468	4-D21,22	EI-306009	3-IC5,6	ER-338183	3-R87
EC-318313	3-C47	ED-200468	6-D17	EI-314647	3-IC10	ER-338184	3-R88,89
EC-321349	5-C43	ED-200468	11-D1,2	EI-315379	7-IC6,7	ER-338184	3-R243
EC-321583	5-C47	ED-200469	4-D14	EI-317653	5-IC5	ER-338186	3-R95
EC-324921	3-C60	ED-200469	8-D8to11	EI-319555	7-IC2	ER-338187	3-R97
EC-327097	3-C82to84	ED-200469	8-D1to3	EI-324255	5-IC7to11	ER-338187	3-R100
EC-327097	3-C12to14	ED-301911	3-D1to4	EI-325755	8-IC1	ER-338221	3-R17,18
EC-327097	3-C28to30	ED-301911	3-D11to13	EI-328690	5-IC3	ER-338221	3-R24
EC-327097	3-C69to71	ED-301911	3-D6to9	EI-330352	4-IC10	ER-338221	3-R119,120
EC-328862	3-C110,111	ED-301911	3-D18to20	EI-330475	5-IC4	ER-338222	3-R19,20
EC-330310	5-C28	ED-301911	4-D26	EI-331275	4-IC2	ER-338222	3-R121,122
EC-334064	5-C60	ED-301911	5-D1to7	EI-336761	3-IC4	ER-338223	3-R90,91
EC-337002	3-C100	ED-301911	5-D9,10	EI-336761	3-IC7	ER-338224	3-R96
EC-337002	3-C143	ED-301911	5-D12,13	EI-336761	3-IC9	ER-338225	3-R101,102
EC-337002	3-C11	ED-301911	5-D15to18	EI-336761	4-IC1	ER-338227	3-R126
EC-337002	3-C27	ED-301911	5-D20,21	EI-336761	4-IC9	ER-338228	3-R134

INDEX

PARTS NO.	REF. NO.	PARTS NO.	REF. NO.	PARTS NO.	REF. NO.	PARTS NO.	REF. NO.
ER-338231	4-R128	ET-328868	5-TR17	EV-337313	14-6x	SK-332694A	13-23
ER-338232	4-R127	ET-328868	5-TR30	EV-337314	14-5x	SK-332694B	13-24x
ER-338233	4-R126	ET-328868	5-TR61,62	EV-338570	5-VR1	SK-332694C	13-25x
ER-338234	4-R125	ET-328868	11-TR2,3	EV-341209	3-VR1	SK-332694D	13-26
ER-338235	4-R124	ET-336997	4-TR16,17	EV-341209	3-VR4	SK-332694E	13-27x
ER-338319	6-R1	ET-336997	4-TR31,32	EV-341209	3-VR8	SK-332694F	13-28x
ER-338325	5-R177	ET-336997	5-TR11to13	EV-341209	5-VR2,3	SK-332699A	13-38
ER-338326	5-R178	ET-337011	9-TR1	EV-464253	9-VR1,2	SK-332699B	13-39x
ER-338498	3-R241,242	ET-337011	9-TR3	EV-483377	3-VR2	SK-332699C	13-40x
ER-338593	7-R27	ET-337012	9-TR4	EV-483377	3-VR7	SK-332706A	15-22
ER-341398	3-R114	ET-337012	9-TR2	EV-522663	7-VR2	SK-332706B	15-23x
ER-341399	3-R202,203	ET-337111	3-TR19	EV-572422	7-VR1	SK-332706C	15-24x
ER-341399	3-R208,209	ET-337234	3-TR29	EV-623193	3-VR10	SK-332707A	15-25
ER-658034	4-R12	ET-337234	3-TR4	EV-648753	5-VR4	SK-332707B	15-26x
ES-283072	3-SW1	ET-337234	5-TR24	EW-201515	14-40x	SK-332707C	15-27x
ES-309311	12-SW1	ET-337234	5-TR33	EW-305691	14-37x	SK-336251	15-4
ES-312234	6-SW1	ET-337235	3-TR44	EW-306427	14-36x	SK-336252	15-5x
ES-312235	6-SW1	ET-337235	3-TR46	EW-306428	14-35	SK-336530A	15-19
ES-312238	6-SW1	ET-337258	3-TR36	EW-313882	14-38x	SK-336530B	15-20x
ES-336780	14-4	ET-337258	3-TR26	EW-313884	14-39x	SK-336530C	15-21x
ES-336990	1-19	ET-337359	5-PH1	HE-337372	1-10	SP-332677A	14-17
ES-337232	14-3x	ET-337760	6-TR8	HP-H2402A010A	1-4	SP-332677B	14-18x
ES-337311	3-SW2	ET-337967	3-TH12	HZ-336129	1-6	SP-332677C	14-19x
ES-337319	3-SW3	ET-337967	3-TR28	HZ-336195	1-9	SP-332677D	14-20x
ES-337319	3-SW4	ET-337967	5-TR25,26	HZ-336205	1-51	SP-332677E	14-21x
ES-337344	1-14	ET-338180	3-TR31	MB-336021	2-25	SP-332677F	14-22x
ES-337349	14-16	ET-338180	3-TR6	MB-336026	2-19	SP-332677G	14-32
ES-691457	13-7	ET-338180	5-TR35	MB-666123	13-8	SP-332684A	15-31
ET-200505	3-TR39to42	ET-338181	3-TR33	MI-336025	2-17	SP-332684B	15-32x
ET-200505	3-TR37	ET-338181	3-TR8	ML-336158	1-59	SP-332684C	15-33x
ET-200505	3-TR45	ET-338181	5-TR37	ML-336159	1-60	SP-336163	1-64
ET-200505	3-TR47to49	ET-338244	3-TR34	MP-336153	1-42	SZ-330911	13-52x
ET-200505	3-TR2,3	ET-338244	3-TR9	MP-336204	1-50	SZ-330911B	13-53x
ET-200505	3-TR14to18	ET-338244	5-TR38	MR-336019	2-24	SZ-336166	1-66
ET-200505	4-TR33	ET-338324	5-TR16	MR-336511	13-6	SZ-631945	14-41
ET-200505	4-TR8,9	ET-338350	3-TR20	MT-305793	1-36	TC-B336004A	2-2
ET-200505	4-TR15	ET-338350	5-TR34	MV-357208	1-56	TC-T2033A040A	13-13
ET-200505	4-TR29	ET-338446	3-TR21	MZ-332667	13-1	TC-332657	13-3
ET-200505	4-TR21to25	ET-338447	3-TR24	MZ-336005	2-4	TC-332661	13-11
ET-200505	11-TR1	ET-341400	3-TR35	MZ-336006	2-8	TC-332666	13-14
ET-200558	5-TR5to10	ET-341400	3-TR10	SA-305646	14-33	TC-336002	2-10
ET-200558	5-TR69	ET-341400	3-TR25	SE-332689A	13-20	TC-336016	2-20
ET-200985	5-TR11to4	ET-539133	4-TR40	SE-332689B	13-21x	TC-336027	2-21
ET-200985	5-TR18to23	ET-554657	3-TR59	SE-332689C	13-22x	TC-336142	1-34
ET-200985	5-TR31,32	ET-554657	4-TR27	SK-B332695A	13-29	TC-336146	1-24
ET-200985	5-TR40,41	ET-554657	4-TR30	SK-B332695B	13-30x	TC-336161	1-62
ET-200985	5-TR43to48	ET-554657	7-TR12	SK-B332695C	13-31x	TC-336506	13-2
ET-200985	5-TR50,51	ET-554657	7-TR3,4	SK-B332696A	13-32	TC-336512	14-27x
ET-200985	5-TR56to60	ET-554657	7-TR1	SK-B332696B	13-33x	TC-336513	14-28x
ET-200985	5-TR63to68	ET-638504	4-TR41	SK-B332696C	13-34x	TC-336605	1-28
ET-200986	6-TR1	ET-639437	3-TR11	SK-B332697A	13-35	TC-342413	13-19
ET-307349	5-TR42	ET-639437	3-TR38	SK-B332697B	13-36x	ZG-312924	14-25x
ET-307349	5-TR49	ET-639437	3-TR43	SK-B332697C	13-37x	ZG-312946	1-39
ET-307349	5-TR70	ET-639437	3-TR60	SK-B332701A	13-41	ZG-312961	13-16
ET-308954	3-TR32	ET-639437	3-TR13	SK-B332701B	13-42	ZG-313031	14-29x
ET-308954	3-TR7	ET-639437	4-TR1	SK-B332701C	13-43x	ZG-313068	14-24x
ET-308954	3-TR22,23	ET-639437	5-TR27to29	SK-B332701D	13-44x	ZG-313070	14-26x
ET-308954	3-TR27	ET-639437	5-TR39	SK-B332704A	13-45	ZG-313152	14-15
ET-308954	5-TR36	ET-639437	5-TR71	SK-B332704B	13-46x	ZG-321534	1-46
ET-308977	5-TR52to55	ET-639437	6-TR3	SK-B332704C	13-47x	ZG-324331	1-38
ET-309353	3-TR55	ET-639437	6-TR5	SK-332640A	15-6	ZG-336011	2-13
ET-310148	3-TR51	ET-639437	6-TR7	SK-332640B	15-7	ZG-336127	1-2
ET-310148	3-TR52	ET-639437	6-TR9	SK-332640C	15-8	ZG-336130	1-8
ET-311977	1-18	ET-639437	7-TR2	SK-332640D	15-9	ZG-336140	1-30
ET-318237	3-TR58	ET-639437	7-TR13to21	SK-332640E	15-10	ZG-336141	1-33
ET-322598	3-TR50	ET-639437	7-TR5to11	SK-332640F	15-11	ZG-336157	1-57
ET-322598	3-TR53	EV-301729	3-VR6	SK-332640G	15-12	ZG-336160	1-61
ET-322598	6-TR2	EV-312338	3-VR9	SK-332640H	15-13	ZG-336175	1-45
ET-322598	6-TR4	EV-314646	5-VR7	SK-332640J	15-14	ZG-336206	1-53
ET-322598	6-TR6	EV-315413	5-VR10	SK-332640K	15-15	ZG-336208	1-55
ET-324134	3-TR56	EV-315416	5-VR9	SK-332640L	15-16	ZG-336524	13-12
ET-324134	11-TR4,5	EV-315752	5-VR6	SK-332641A	15-17	ZG-336615	1-65
ET-328437	3-TR1	EV-321637	5-VR5	SK-332641B	15-18	ZG-341972	1-13
ET-328440	3-TR57	EV-321637	5-VR8	SK-332645A	14-7	ZS-300519	14-58x
ET-328578	3-TR30	EV-330369	3-VR3	SK-332645B	14-8x	ZS-301398	14-48x
ET-328578	3-TR54	EV-330369	3-VR5	SK-332645C	14-9x	ZS-310337	1-15
ET-328578	3-TR5	EV-337052	2-3	SK-332646A	14-10	ZS-312963	13-55
ET-328868	4-TR10to14	EV-337106	14-13x	SK-332646B	14-11x	ZS-341963	15-34
ET-328868	4-TR19,20	EV-337310	14-2x	SK-332646C	14-12x	ZS-341964	15-35x
ET-328868	5-TR14,15	EV-337312	14-1x	SK-332685	14-14	ZS-342002	1-58

INDEX

PARTS NO.	REF. NO.	PARTS NO.	REF. NO.	PARTS NO.	REF. NO.	PARTS NO.	REF. NO.
ZS-342086	1-11						
ZS-356681	13-54						
ZS-432843	2-5						
ZS-447761	14-23						
ZS-447840	14-49						
ZS-463353	14-50x						
ZS-477876	1-5						
ZS-477876	2-14						
ZS-477876	2-23						
ZS-479474	2-11						
ZS-494842	14-34x						
ZS-499331	1-12						
ZS-563444	1-29						
ZS-608095	1-3						
ZS-608095	1-52						
ZW-270088	1-17						
ZW-270088	1-40						
ZW-270088	13-4						
ZW-305013	15-36x						
ZW-306464	1-48						
ZW-309295	2-18						
ZW-312121	14-30x						
ZW-330073	1-35						
ZW-336603	1-47						
ZW-336603	2-7						
ZW-336604	2-9						
ZW-356657	1-44						
ZW-381644	1-43						
ZW-618884	1-7						
ZW-618884	1-54						
ZW-698308	14-31x						

SECTION 4

SCHEMATIC DIAGRAM

1. SCHEMATIC DIAGRAM OF ICs	77
2. GX-F91 NO. 5-1 1641208A CONNECTION DIAGRAM	85
3. GX-F91 SYSCON NO. 5-2 1641209A SCHEMATIC DIAGRAM	86
4. GX-F91 AMP NO. 5-3 1641210A SCHEMATIC DIAGRAM	87
5. GX-F91 TUNING NO. 5-4 1641211A SCHEMATIC DIAGRAM	88
6. GX-F91 METER NO. 5-5 1641212A SCHEMATIC DIAGRAM	89

AM1408N8

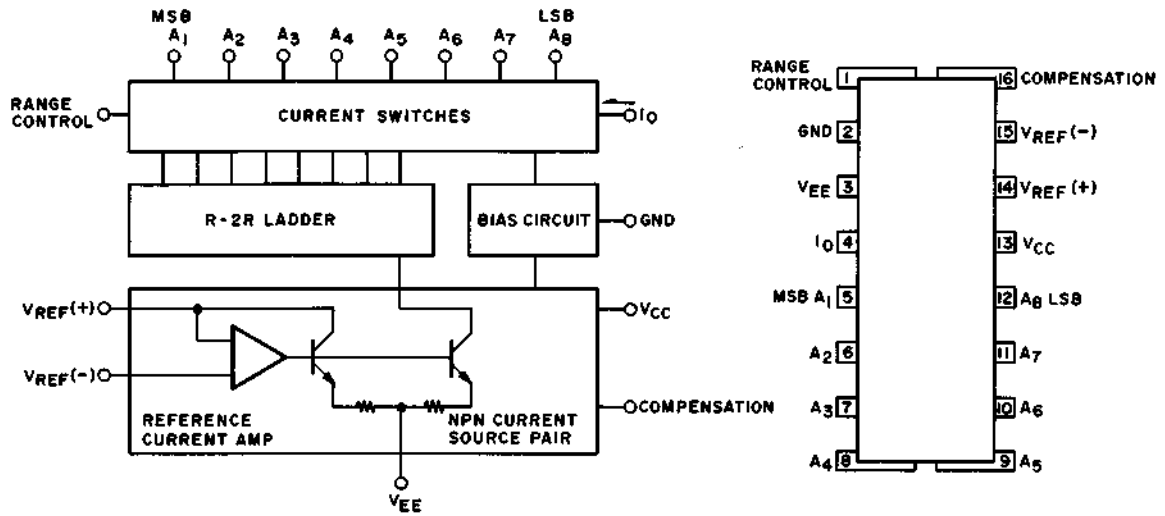

BA6109

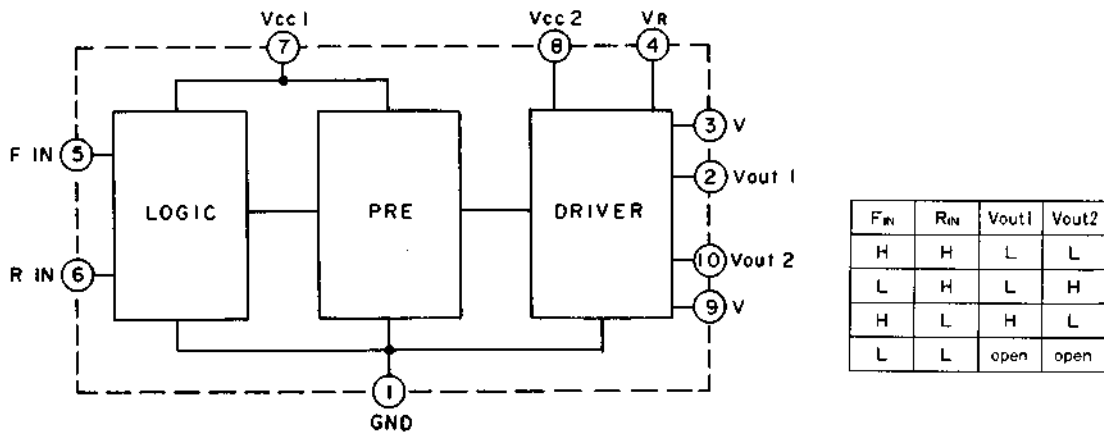

LA6458S, NJM4558S

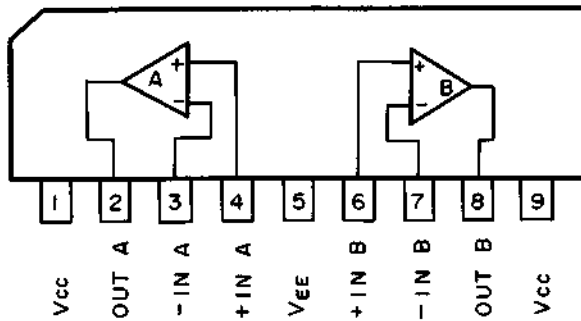

LC4049

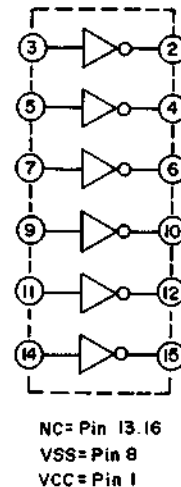

LB1290

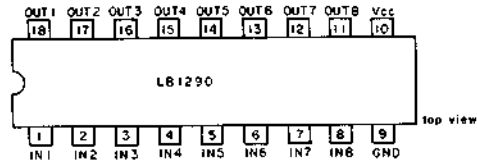
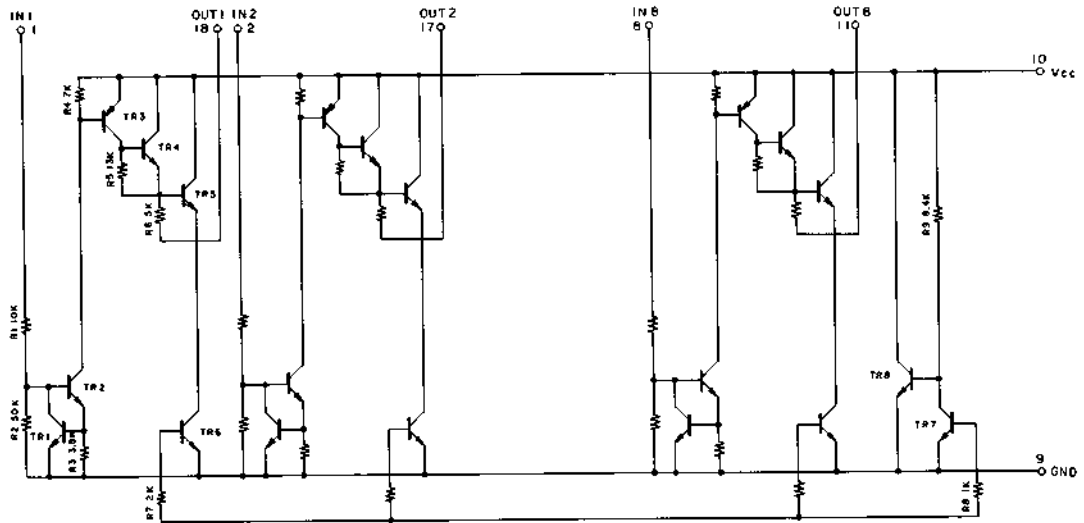

LC7550

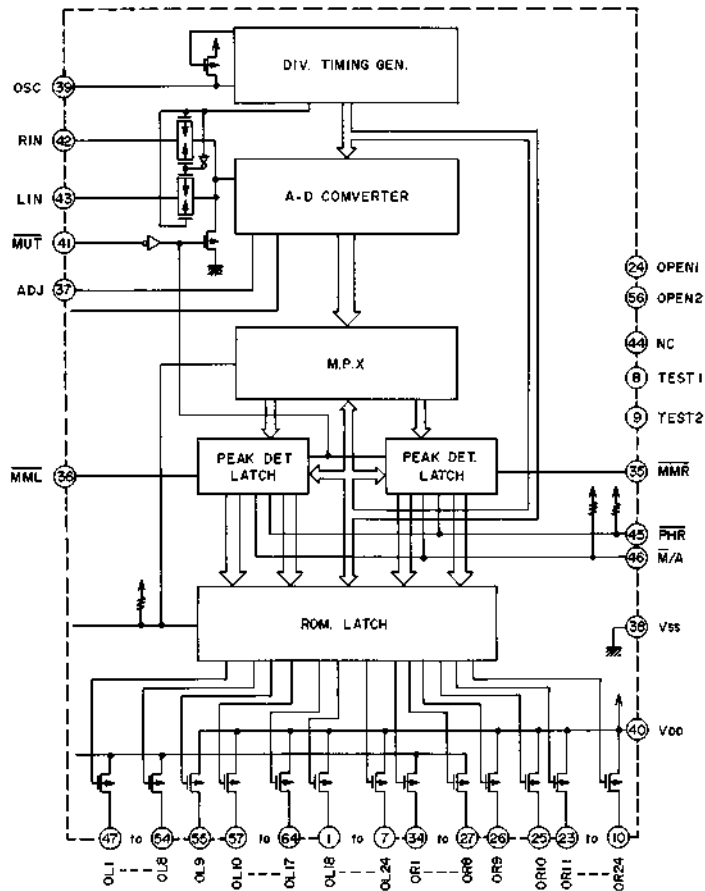

LC7800

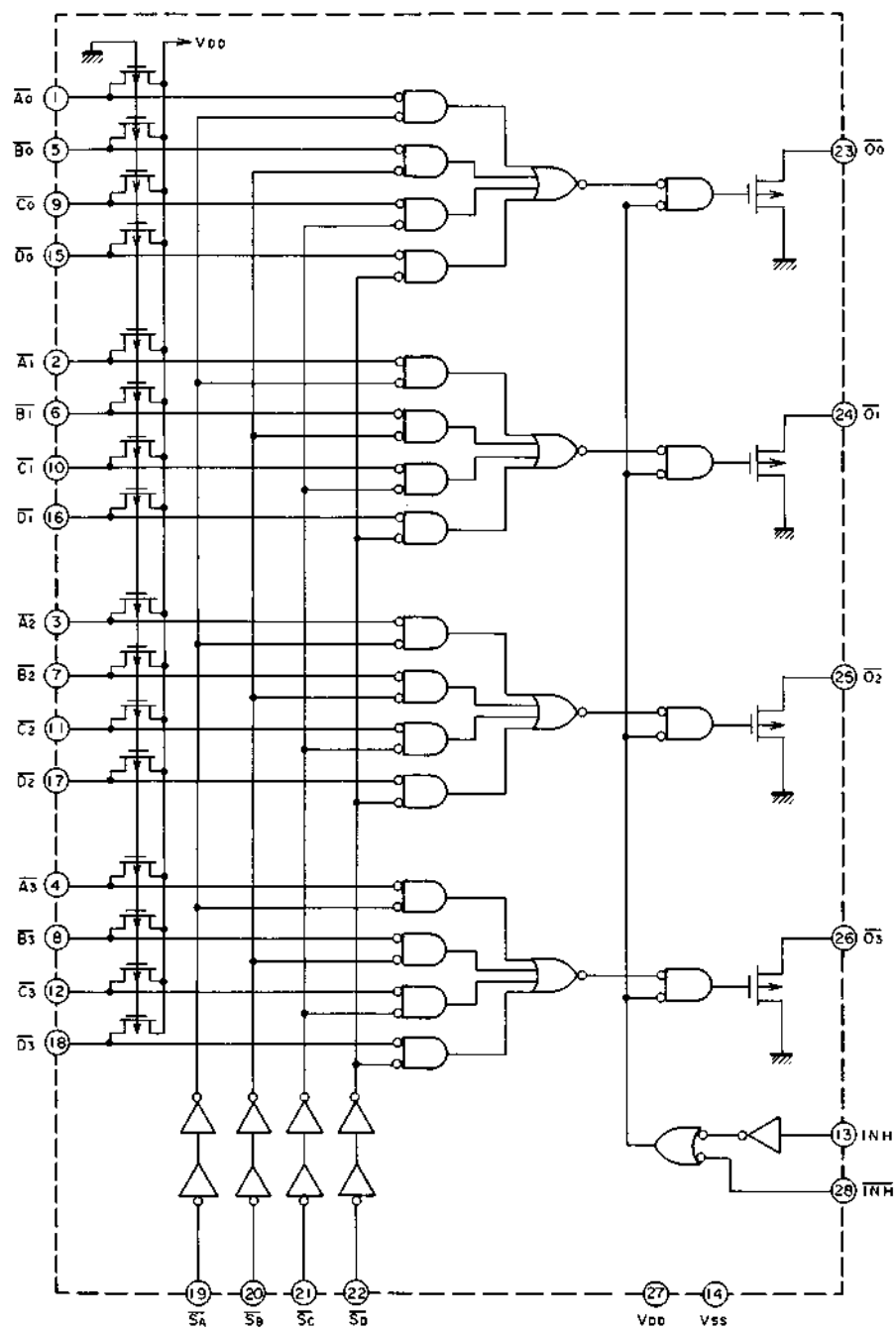

LM111A

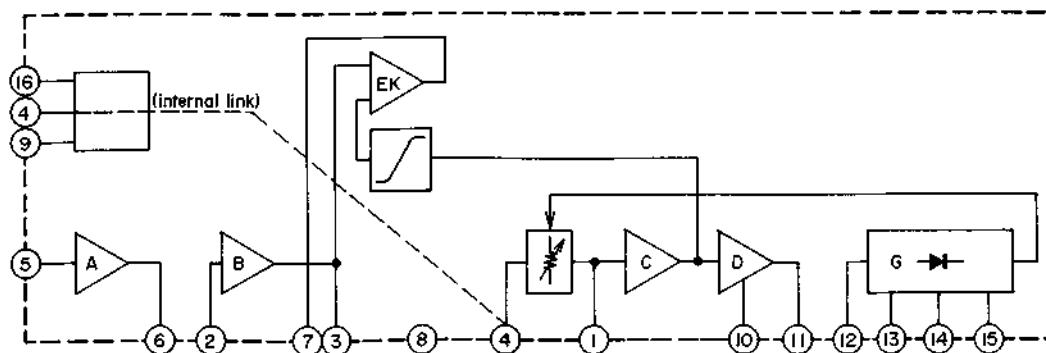

LM13600N

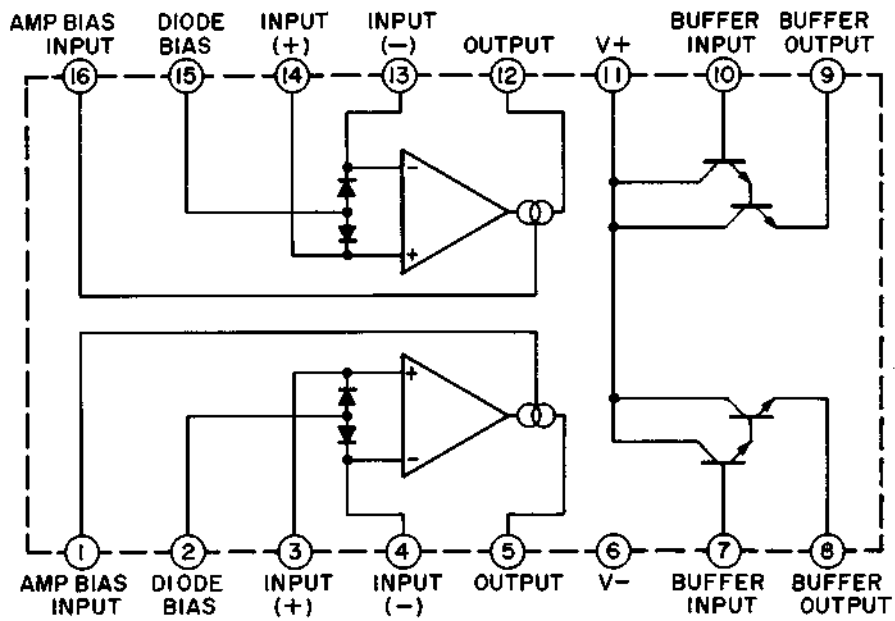
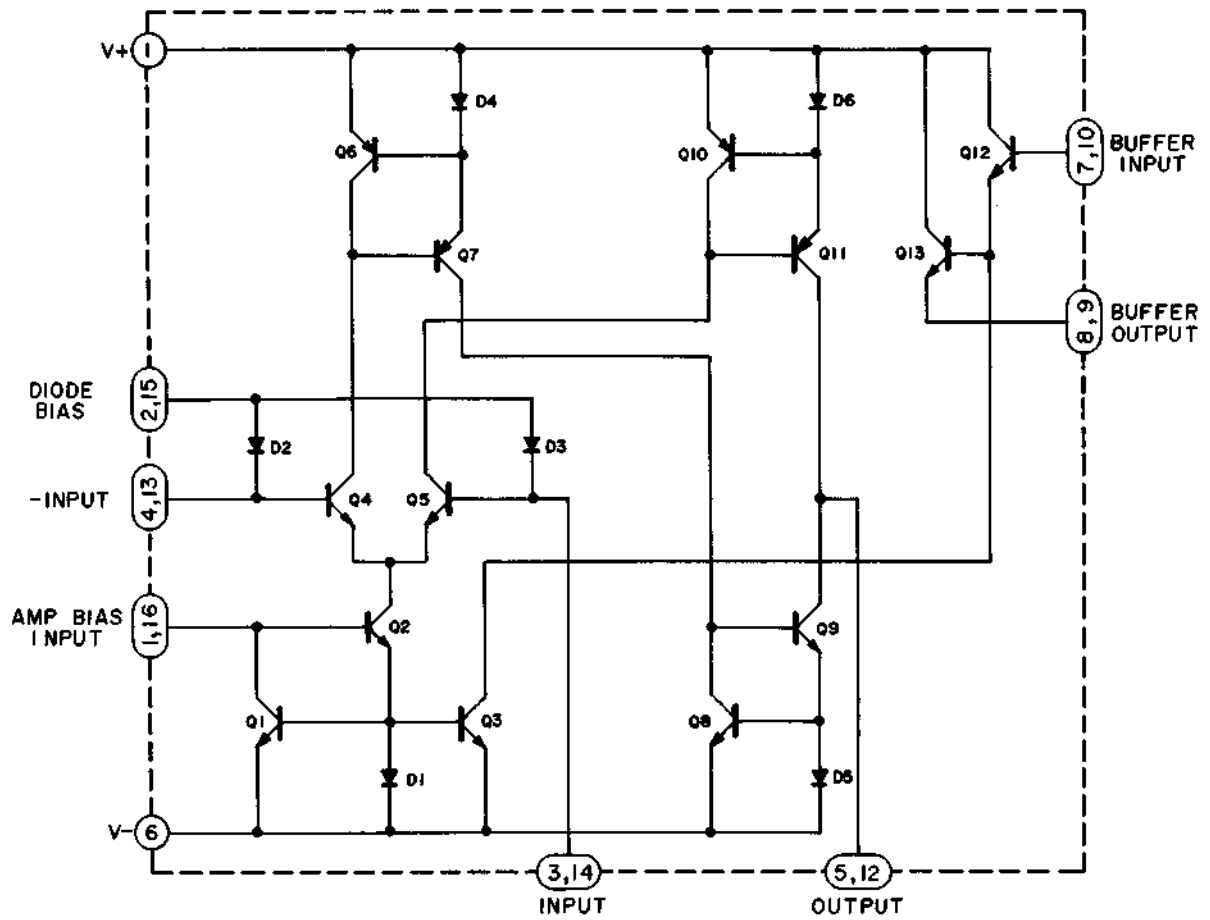

M5L5101P

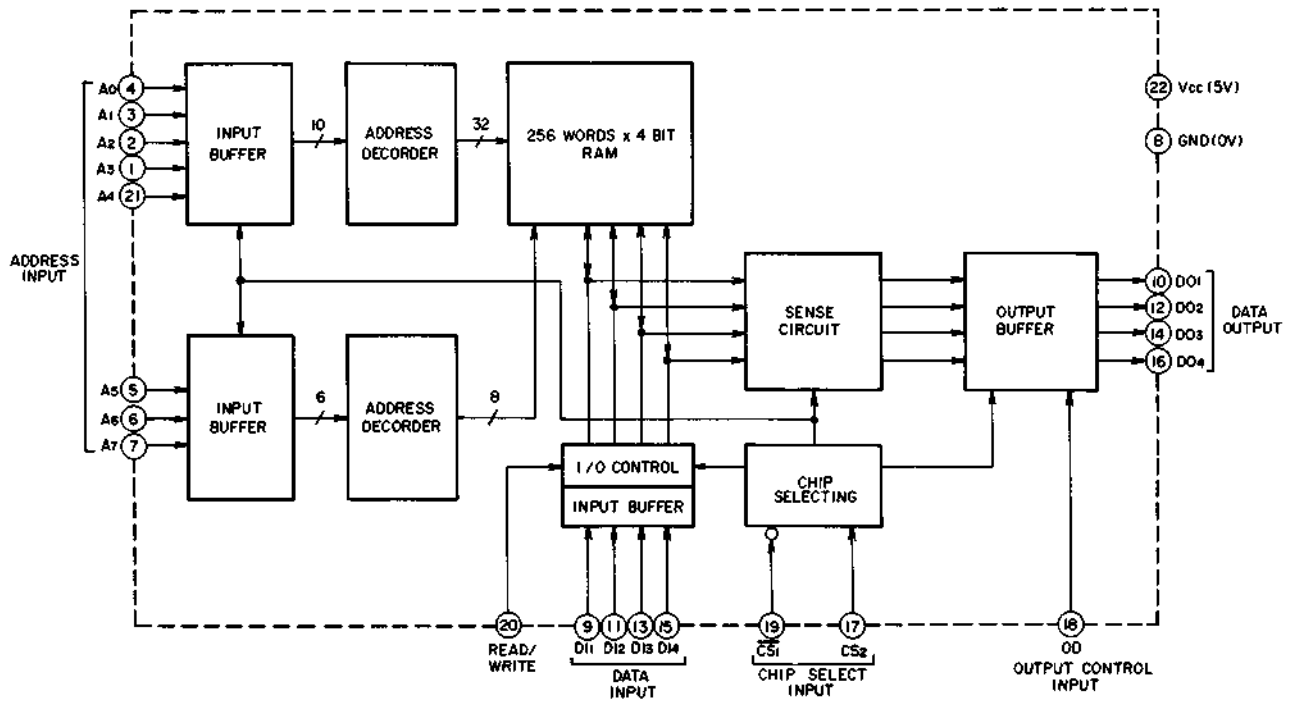

M5230L

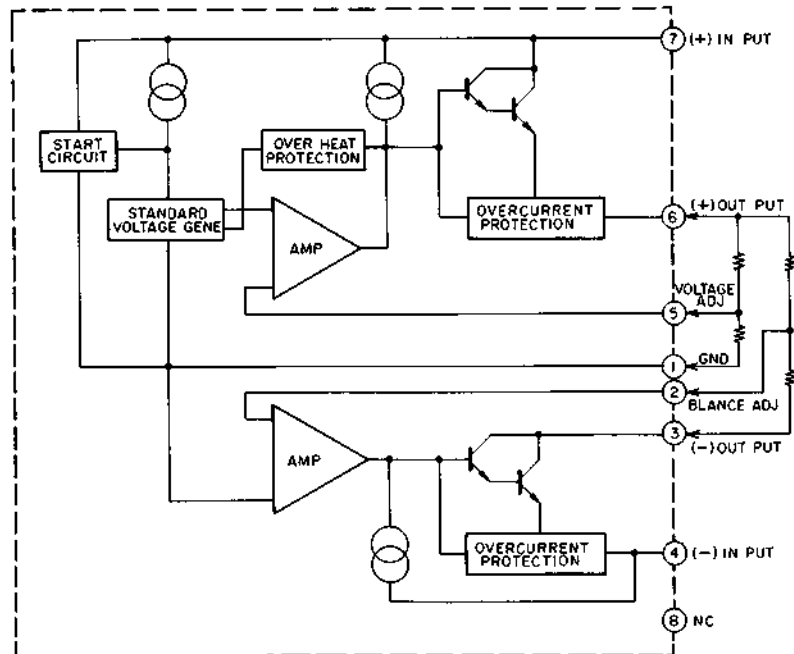
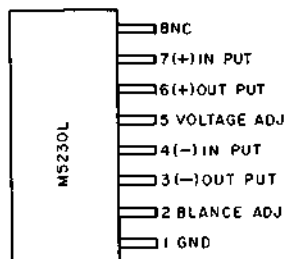

NJM4558D

μ PC4082C, TL082CP

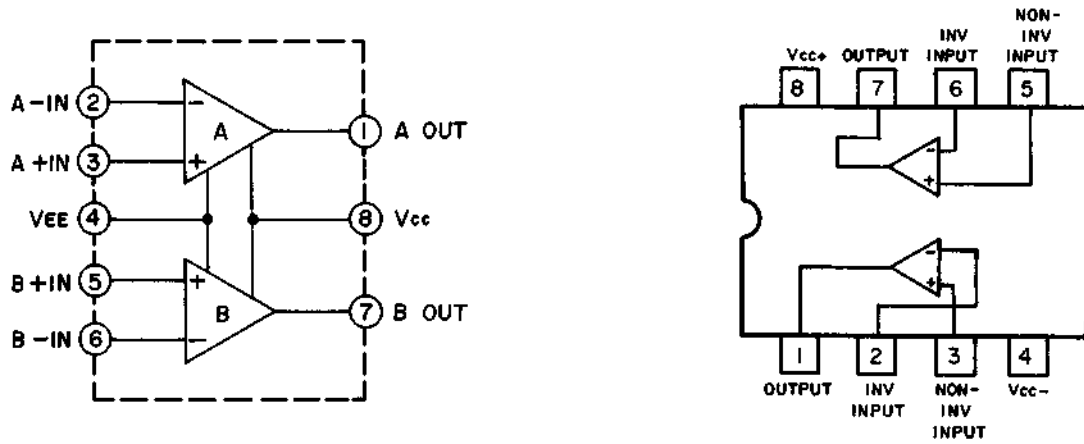

TA7179P

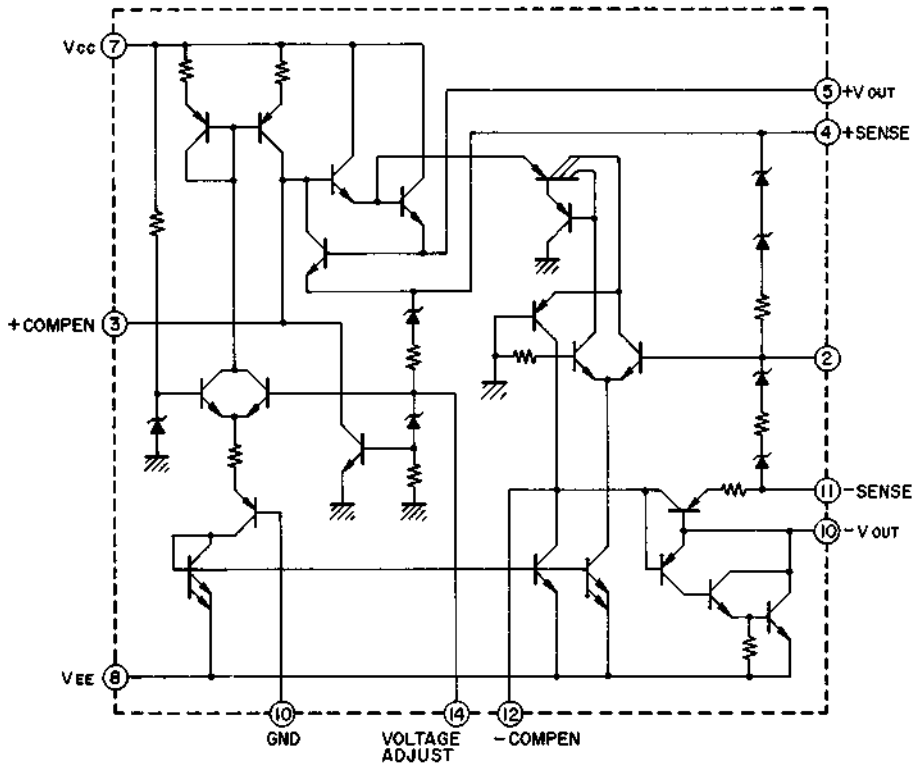

TA7332P

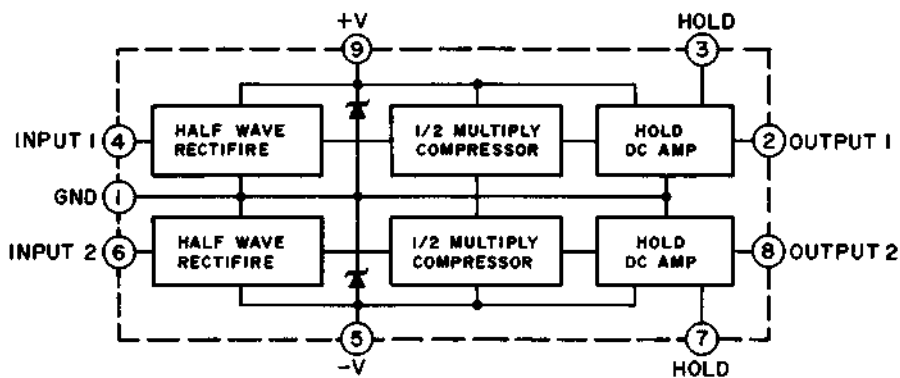

TC9142P

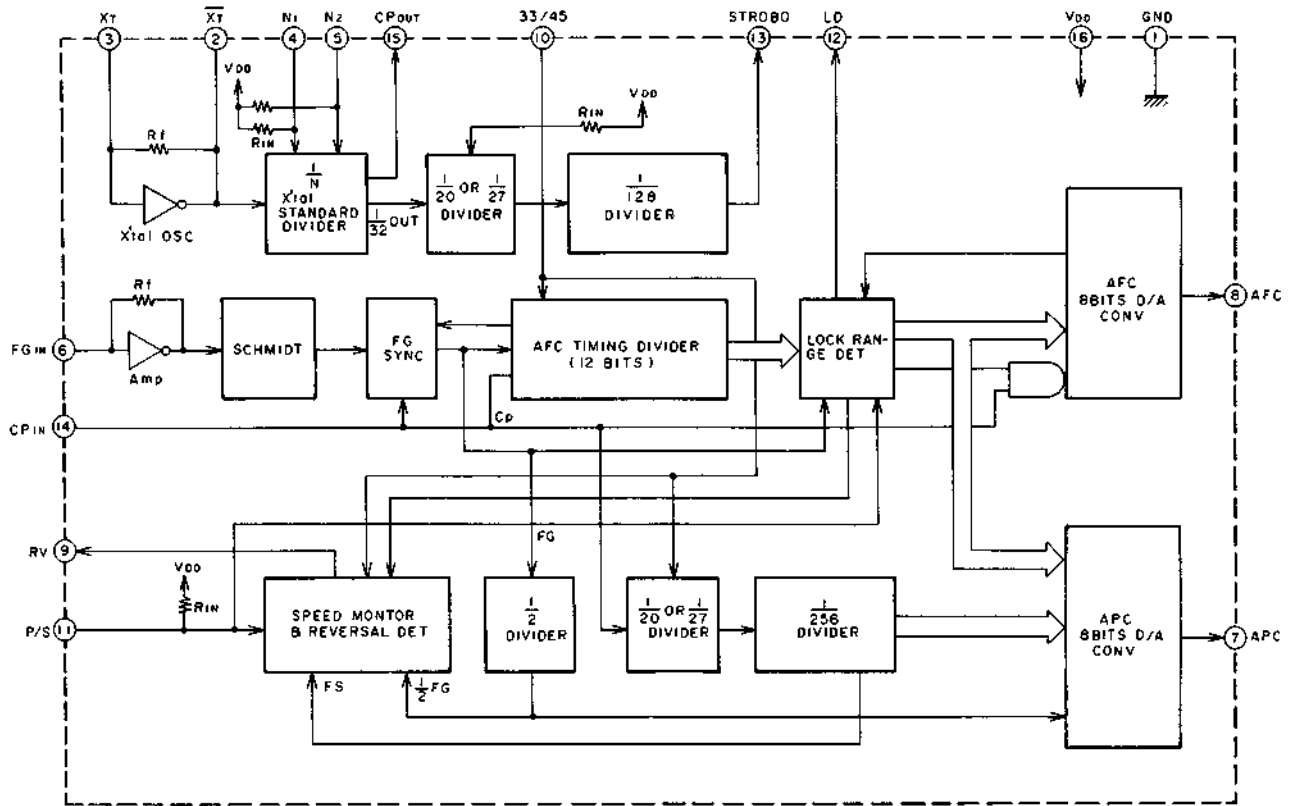

μPD4051

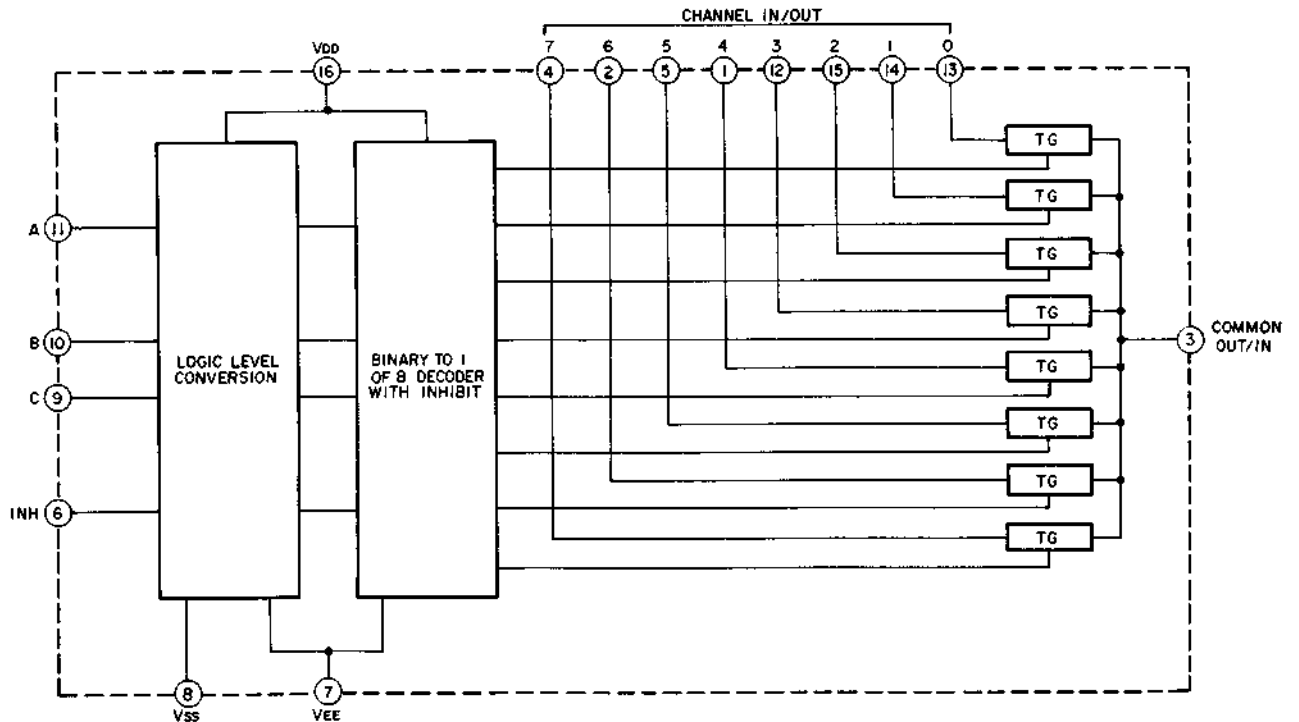

μ PD4066C

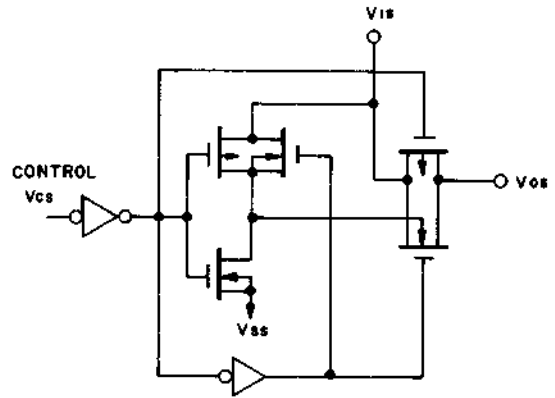
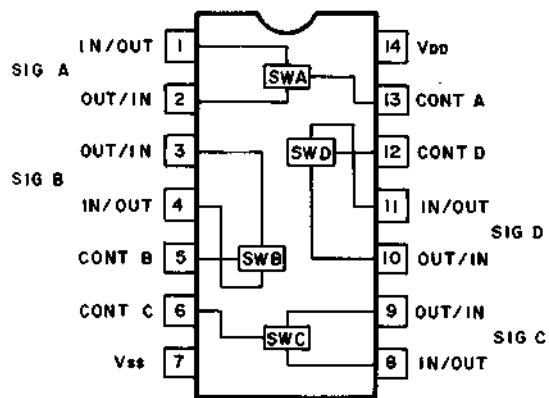

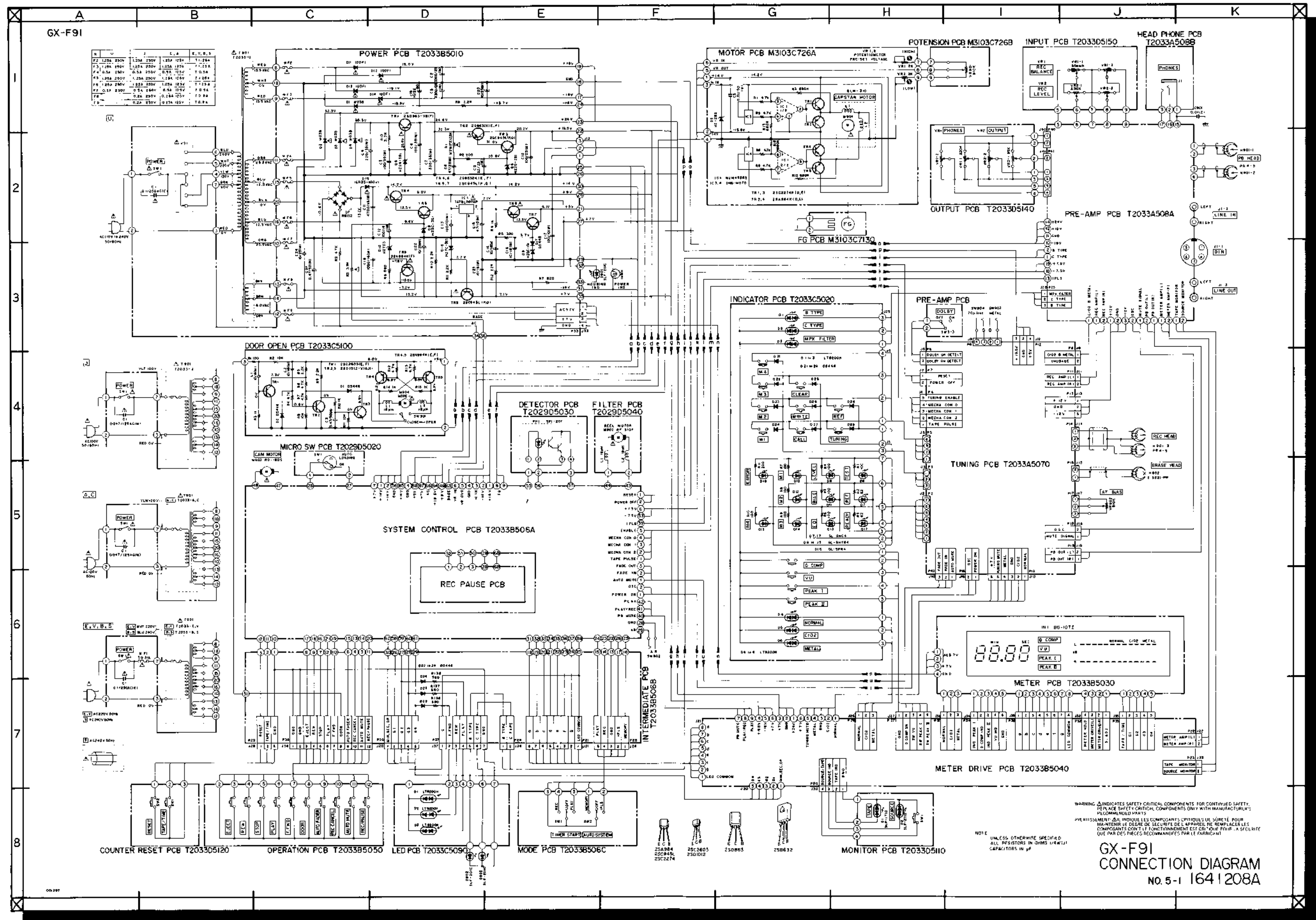

GX-F91

W	V	C	E, V, R, S
W2	1.25A 250V	1.25A 250V	T1.25A
F3	1.0A 250V	1.0A 250V	T1.0A
F4	0.5A 250V	0.5A 250V	T0.5A
F5	0.25A 250V	0.25A 250V	T0.25A
F6	0.1A 250V	0.1A 250V	T0.1A
F7	0.05A 250V	0.05A 250V	T0.05A
F8	0.025A 250V	0.025A 250V	T0.025A
F9	0.0125A 250V	0.0125A 250V	T0.0125A

WARNING: INDICATES SAFETY CRITICAL COMPONENTS. FOR CONTINUED SAFETY, REPLACE SAFETY CRITICAL COMPONENTS ONLY WITH MANUFACTURER'S RECOMMENDED PARTS.
 AVERTISSEMENT: IL INDIQUE LES COMPOSANTS CRITIQUES DE SÛRETÉ POUR LA DURÉE DE VIE DE L'APPAREIL. NE REMPLACEZ LES COMPOSANTS CRITIQUES QUE PAR DES PIÈCES RECOMMANDÉES PAR LE FABRICANT.

NOTE: UNLESS OTHERWISE SPECIFIED, ALL RESISTORS IN OHMS (Ω), KΩ (K), MΩ (M), CAPACITORS IN μF.

GX-F91
 CONNECTION DIAGRAM
 NO. 5-1 1641208A

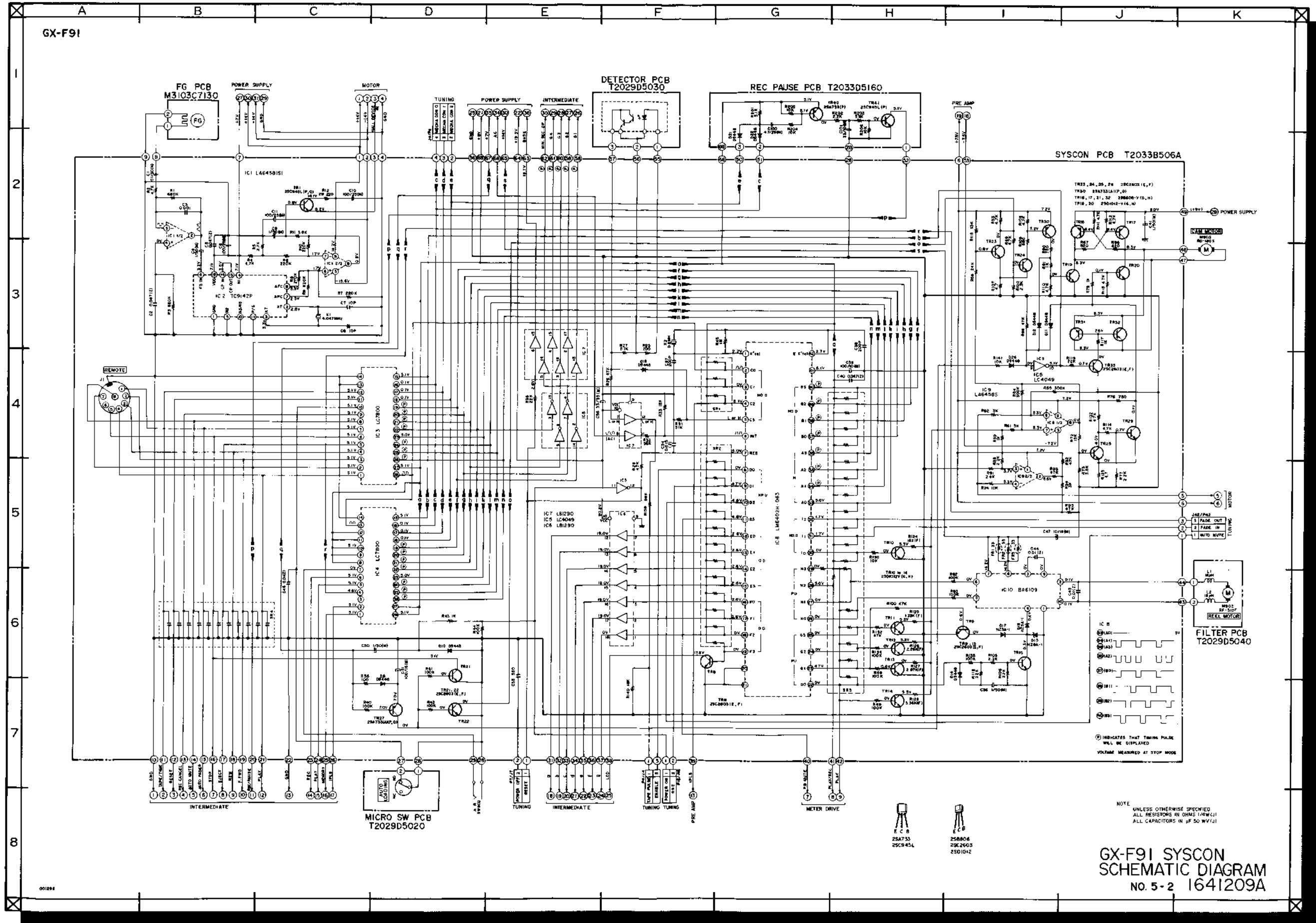

GX-F91 SYSCON
SCHEMATIC DIAGRAM
No. 5-2 1641209A

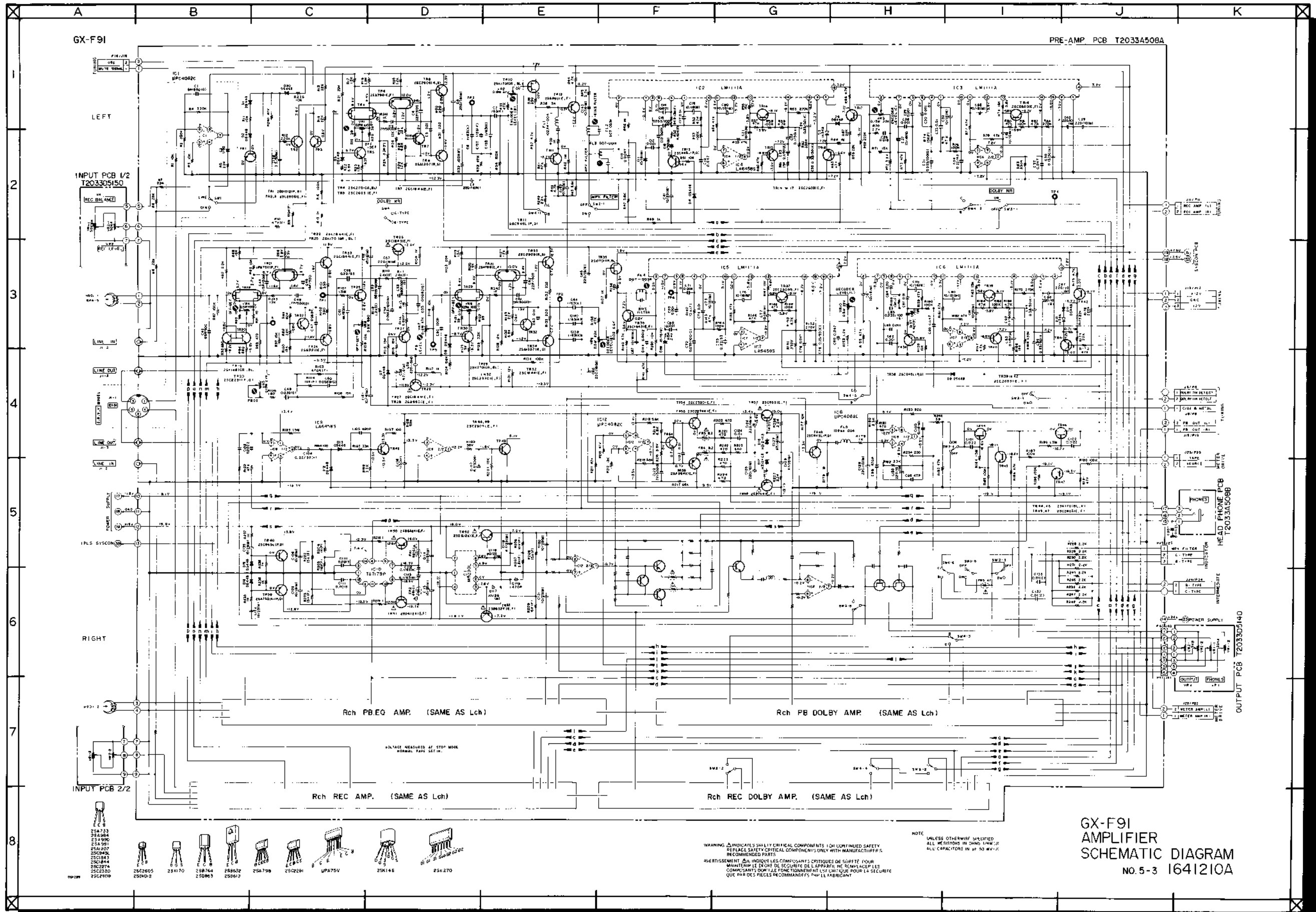

GX-F91

PRE-AMP PCB T2033A508A

LEFT

INPUT PCB 1/2
T203305150

LINE OUT

PLS SYSTEM

RIGHT

INPUT PCB 2/2

Rch PB EQ AMP (SAME AS Lch)

Rch PB DOLBY AMP (SAME AS Lch)

Rch REC AMP (SAME AS Lch)

Rch REC DOLBY AMP (SAME AS Lch)

VOLAGE MEASURED AT STOP MODE
NORMAL PAPE SET IN

- 25A723
- 25A104
- 25A990
- 25A951
- 25A907
- 25C006
- 25C1843
- 25C1844
- 25C2874
- 25C2330
- 25C2910
- 25A2605
- 25A110
- 25A803
- 25A502
- 25A562
- 25A709
- 25C20H
- UPA75V
- 25K145
- 25H270

WARNING: INDICATES SAFETY CRITICAL COMPONENTS FOR LIMITED SAFETY
 REPLACE SAFETY CRITICAL COMPONENTS ONLY WITH MANUFACTURER'S
 RECOMMENDED PARTS.
 AVERTISSEMENT: INDIQUE LES COMPOSANTS CRITIQUES DE SURETE (POUR
 MAINTENIR LE DROIT DE SECURITE DE L'APPAREIL) NE REMPLACEZ LES
 COMPOSANTS QUE PAR LES TOMBEMENTS AVEC UNE VERIFICATION POUR LA SECURITE
 QUE PAR DES PIECES RECOMMANDÉES PAR LE FABRICANT.

NOTE: UNLESS OTHERWISE SPECIFIED
 ALL RESISTORS IN OHMS (WAVE)
 ALL CAPACITORS IN UF (WAVE)

GX-F91
 AMPLIFIER
 SCHEMATIC DIAGRAM
 NO. 5-3 1641210A

GX-F91

LEFT

INPUT PCB 1/2
T2033D5150

H001-1
RPA-5

LINE IN
J1-2

LINE OUT
J1-5

LINE IN
J1-2

LINE OUT
J1-5

POWER SUPPLY
17 -18V
18 GND
19 +18V

IPLS SYSCON

RIGHT

H001-2

INPUT PCB 2/2

F C B

- 25A733
- 25A984
- 25A990
- 25A991
- 25A1207
- 25C945L
- 25C1843
- 25C1844
- 25C2274
- 25C2320
- 25C2909

- 25C2603
- 25D0102

- 25K170

- 25B764
- 25B863

- 25B632
- 25D612

- 25A798

- 25C2291

- JPA75V

- 25K146

- 25K270

001999

A

B

C

D

E

F

TUNING
P18/J18
OSC 2
MUTE SIGNAL 1

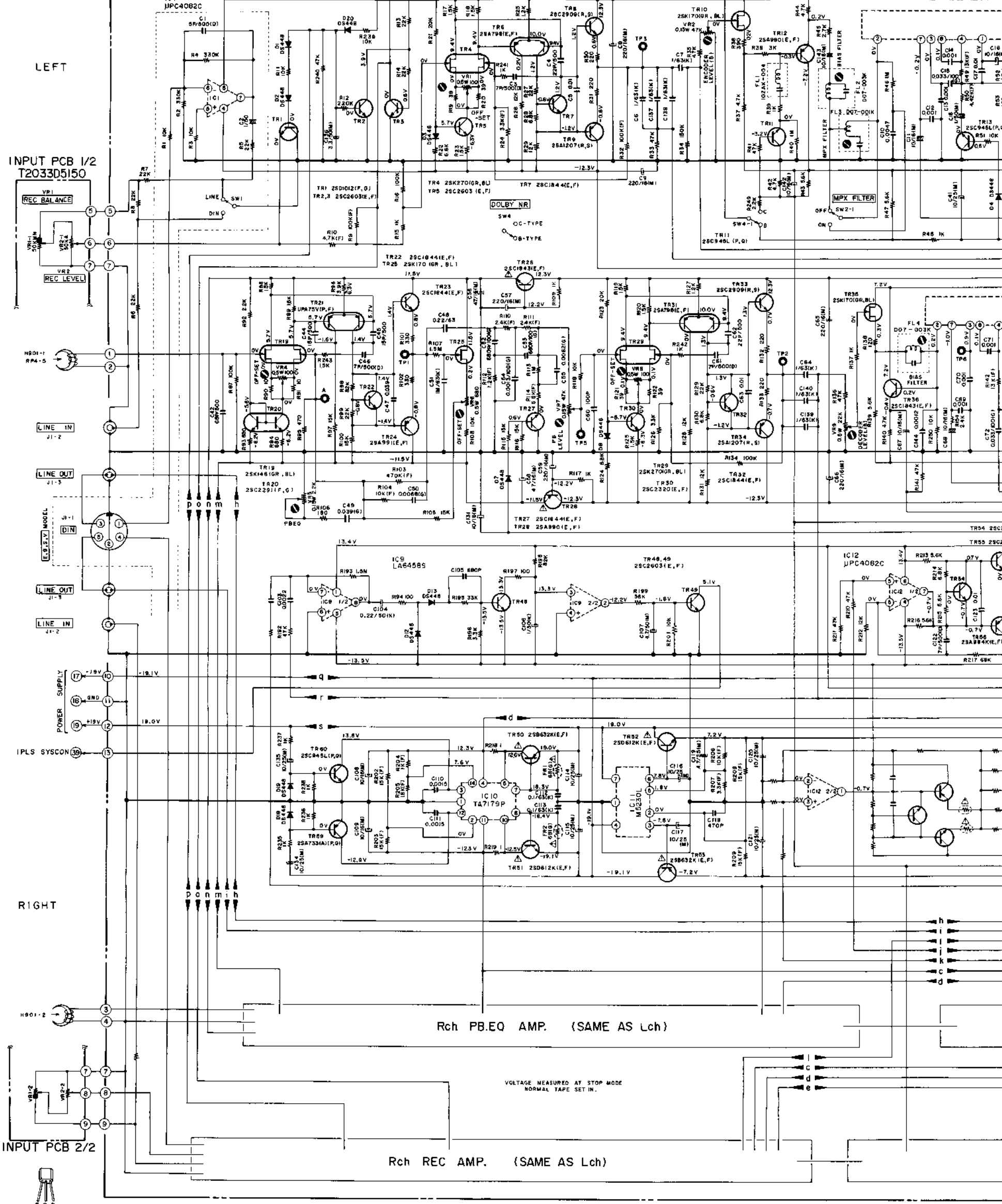

Rch P.BEQ AMP. (SAME AS Lch)

VOLTAGE MEASURED AT STOP MODE
NORMAL TAPE SET IN.

Rch REC AMP. (SAME AS Lch)

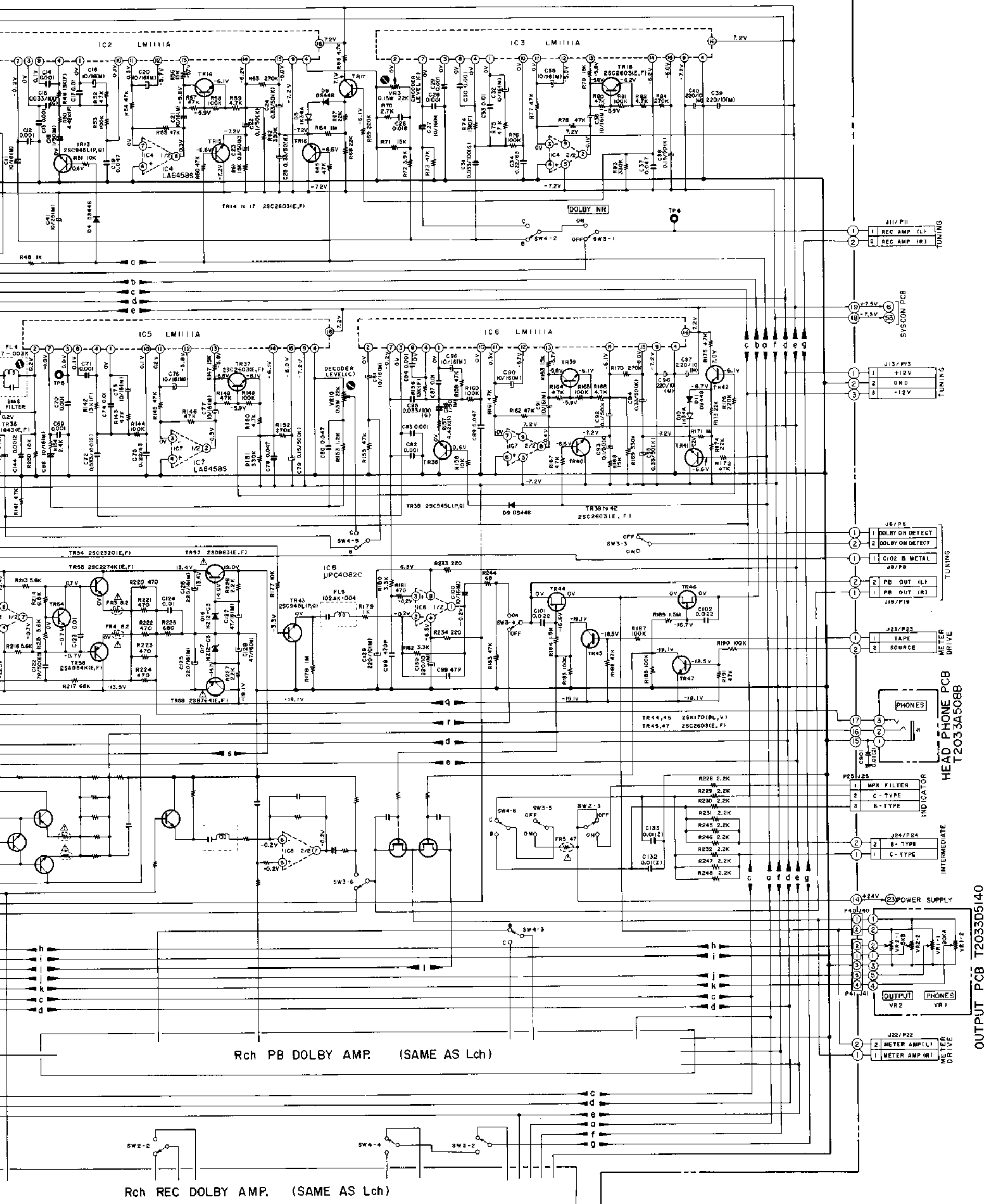

Rch PB DOLBY AMP. (SAME AS Lch)

Rch REC DOLBY AMP. (SAME AS Lch)

WARNING: Δ INDICATES SAFETY CRITICAL COMPONENTS FOR CONTINUED SAFETY. REPLACE SAFETY CRITICAL COMPONENTS ONLY WITH MANUFACTURER'S RECOMMENDED PARTS.
 AVERTISSEMENT: Δ IL INDIQUE LES COMPOSANTS CRITIQUES DE SÛRETÉ. POUR MAINTENIR LE Degré DE SÛRETÉ DE L'APPAREIL, NE REMPLACER LES COMPOSANTS DONT LE FONCTIONNEMENT EST CRITIQUE POUR LA SÛRETÉ QUE PAR DES PIÈCES RECOMMANDÉES PAR LE FABRICANT.

NOTE: UNLESS OTHERWISE SPECIFIED, ALL RESISTORS IN OHMS (1/4W/1/1) ALL CAPACITORS IN μ F 50 WV(1)

GX-F91
 AMPLIFIER
 SCHEMATIC DIAGRAM
 NO. 5-3 1641210A

GX-F91

- 2SA990
- 2SA107
- 2SC945L
- 2SC1844
- 2SC2909
- 2SC2274
- 2SA1115
- 2SB808-V
- 2SC2603
- 2SD1012-V
- 2SD794
- 2SA798
- 2SC2291

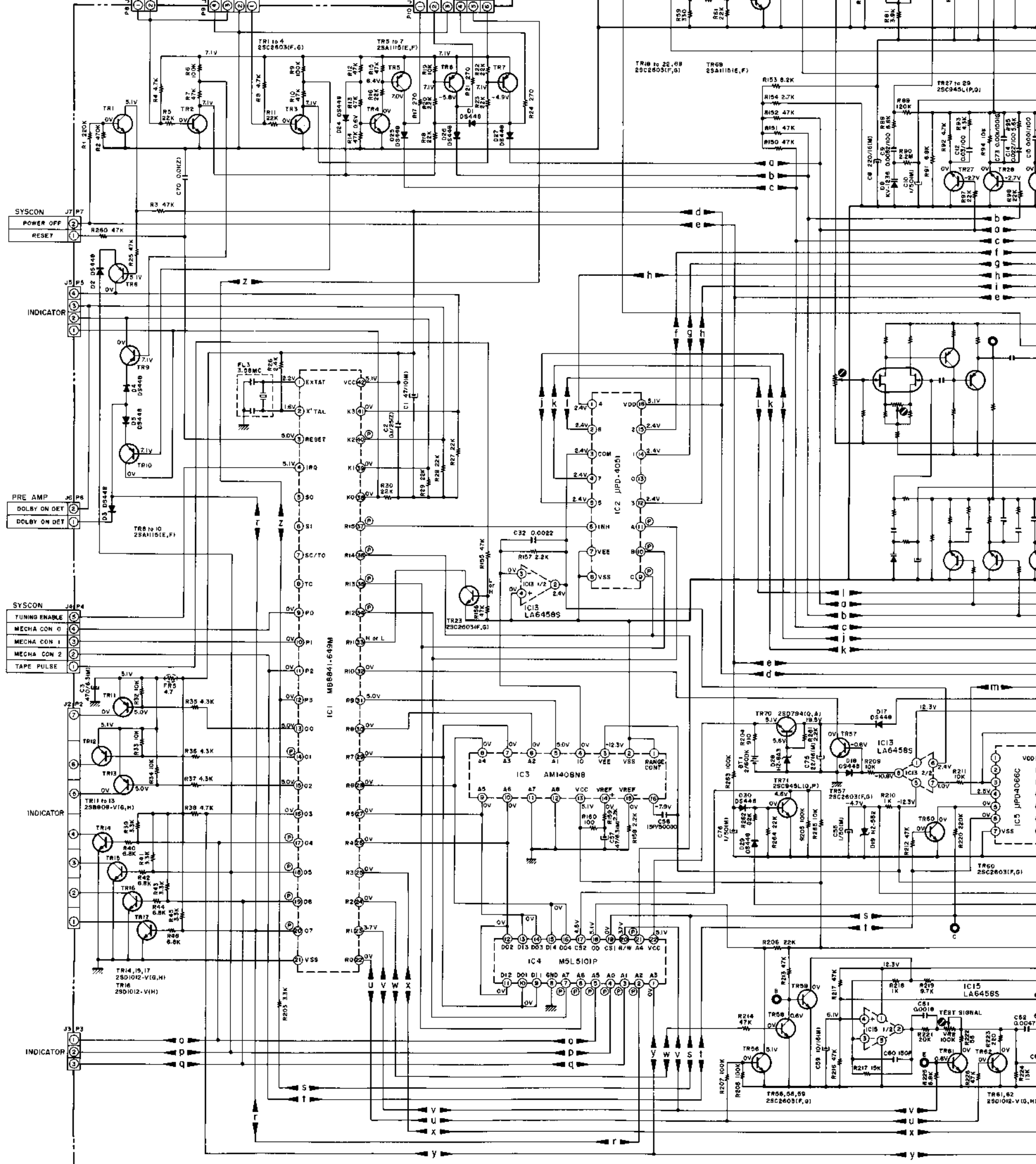
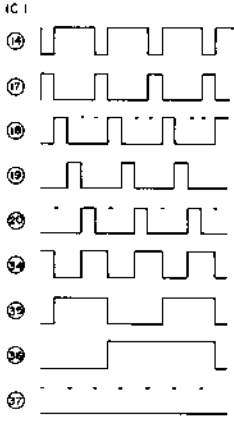
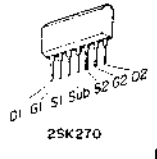

1
2
3
4
5
6
7
8

A B C D E F

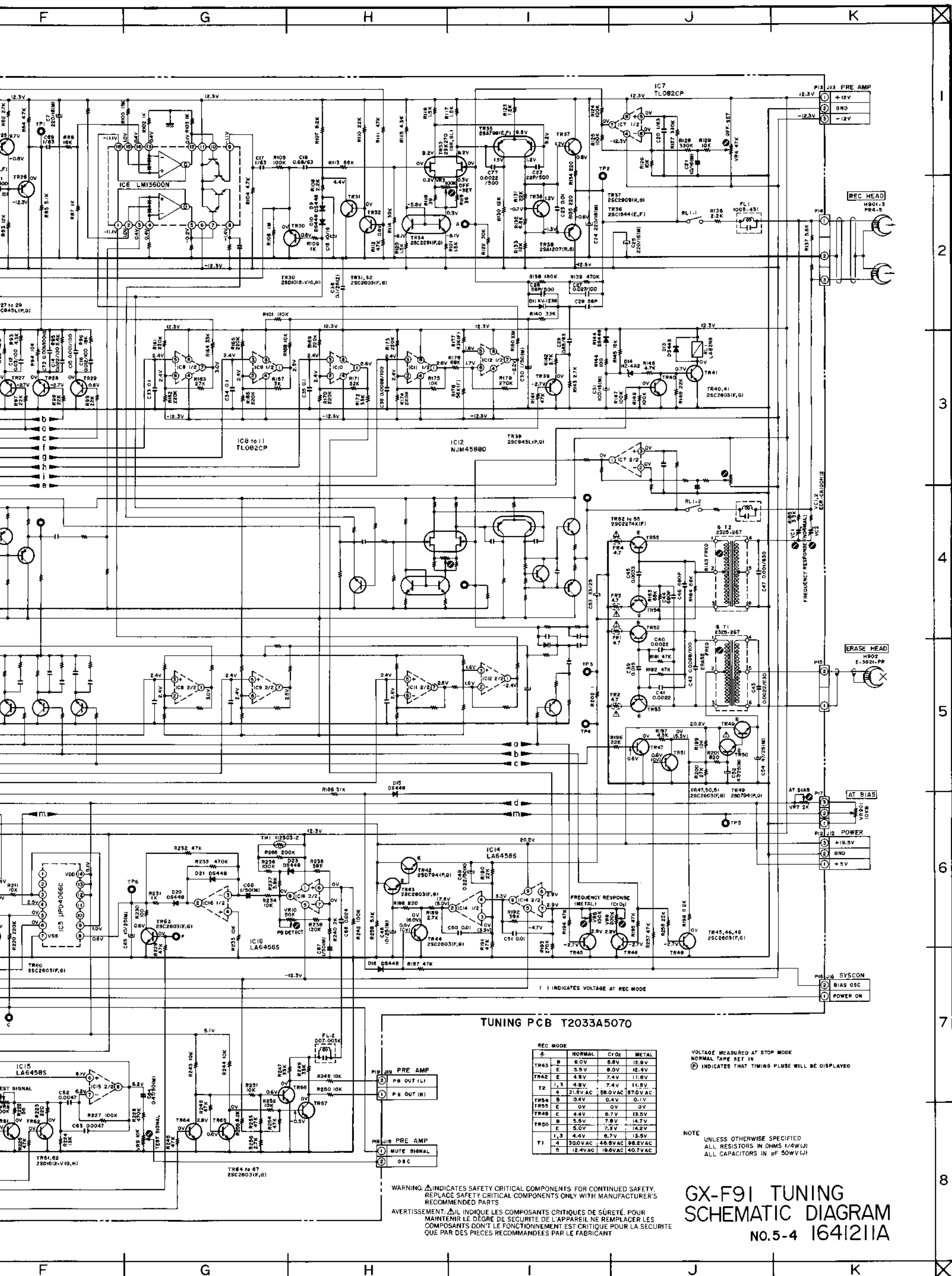

TUNING PCB T2033A5070

REC MODE	NORMAL	CF02	METAL
TR43	B 8.0V	8.8V	12.9V
	E 5.5V	8.0V	12.4V
TR42	E 4.9V	7.4V	11.8V
T2	1,3 4.8V	7.4V	11.8V
	4 21.8V AC	30.0V AC	87.0V AC
TR54	B 0.4V	0.4V	0.1V
TR55	E 0V	0V	0V
TR49	E 4.4V	6.7V	13.5V
TR40	B 5.5V	7.8V	14.7V
	E 5.0V	7.5V	14.2V
T1	1,3 4.4V	6.7V	13.5V
	4 30.0V AC	46.8V AC	86.8V AC
	0 12.4V AC	18.6V AC	40.7V AC

VOLTAGE MEASURED AT STOP MODE
NORMAL TAPE SET IN
Ⓢ INDICATES THAT TIMING PULSE WILL BE DISPLAYED

NOTE
UNLESS OTHERWISE SPECIFIED
ALL RESISTORS IN OHMS 1/4W(J)
ALL CAPACITORS IN pF 50WV(J)

WARNING: ⚠ INDICATES SAFETY CRITICAL COMPONENTS. FOR CONTINUED SAFETY, REPLACE SAFETY CRITICAL COMPONENTS ONLY WITH MANUFACTURER'S RECOMMENDED PARTS.
AVERTISSEMENT: ⚠ IL INDIQUE LES COMPOSANTS CRITIQUES DE SÛRETÉ. POUR MAINTENIR LE Degré DE SÛRETÉ DE L'APPAREIL, NE REMPLACER LES COMPOSANTS DON'T LE FONCTIONNEMENT EST CRITIQUE POUR LA SÛRETÉ QUE PAR DES PIÈCES RECOMMANDÉES PAR LE FABRICANT.

GX-F91 TUNING SCHEMATIC DIAGRAM No.5-4 1641211A