

AKAI SERVICE MANUAL

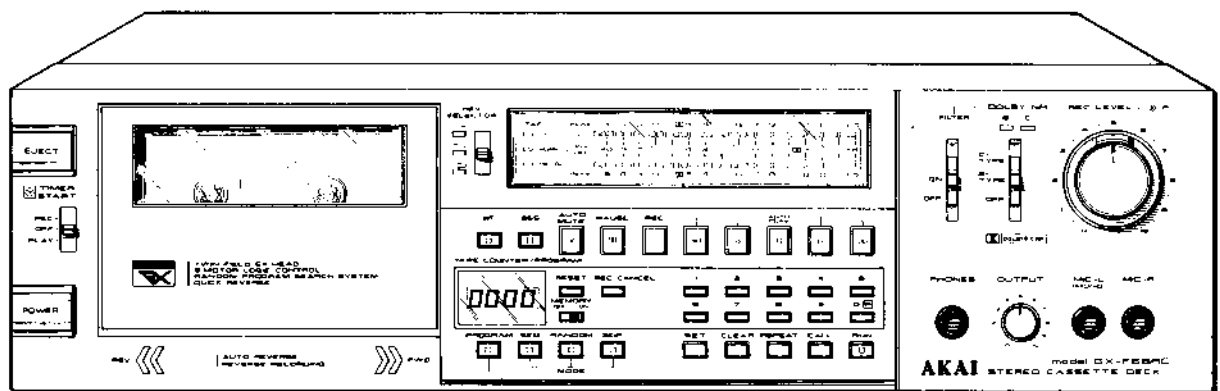

STEREO CASSETTE DECK

MODEL **GX-F66RC**

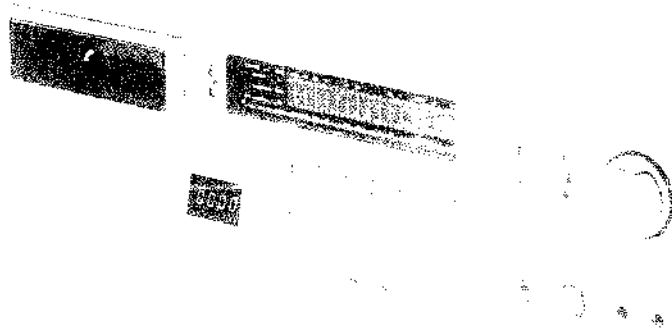

Power Supply Unit
Model: PS-1000

Manufacturer: ABC Electronics

1000W

24VDC

10A

1000W

24VDC

10A

SAFETY INSTRUCTIONS

SAFETY CHECK AFTER SERVICING

Confirm the specified insulation resistance between power cord plug prongs and externally exposed parts of the set is greater than 10 Mohms, but for equipment with external antenna terminals (tuner, receiver, etc.) and is intended for **C** or **A**, specified insulation resistance should be more than 2.2 Mohms (ground terminals, microphone jacks, headphone jacks, line-in-out jacks etc.)

PRECAUTIONS DURING SERVICING

1. Parts identified by the Δ symbol parts are critical for safety.
Replace only with parts number specified.
2. In addition to safety, other parts and assemblies are specified for conformance with such regulations as those applying to spurious radiation. These must also be replaced only with specified replacements.
Examples: RF converters, tuner units, antenna selector switches, RF cables, noise blocking capacitors, noise blocking filters, etc.
3. Use specified internal wiring. Note especially:
 - 1) Wires covered with PVC tubing
 - 2) Double insulated wires
 - 3) High voltage leads
4. Use specified insulating materials for hazardous live parts. Note especially:
 - 1) Insulation Tape
 - 2) PVC tubing
 - 3) Spacers (Insulating Barriers)
 - 4) Insulation sheets for transistors
5. When replacing AC primary side components (transformers, power cords, noise blocking capacitors, etc.), wrap ends of wires securely about the terminals before soldering.

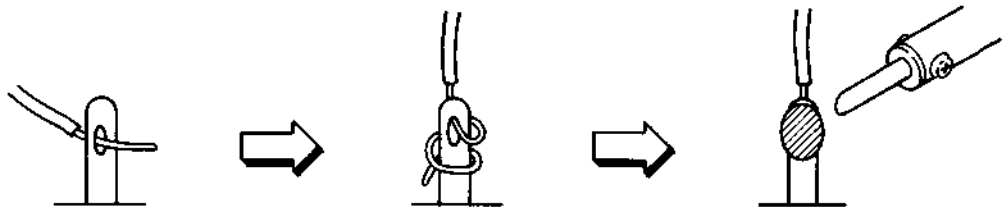

6. Observe that wires do not contact heat producing parts (heatsinks, oxide metal film resistors, fusible resistors, etc.).
7. Check that replaced wires do not contact sharp edged or pointed parts.
8. Also check areas surrounding repaired locations.
9. Use care that foreign objects (screws, solder droplets, etc.) do not remain inside the set.

SECTION 1

SERVICE MANUAL

TABLE OF CONTENTS

I.	SPECIFICATIONS	4
II.	CONTROLS	5
III.	PRINCIPAL PARTS LOCATION	6
IV.	VOLTAGE AND CYCLE CONVERSION	7
	1. VOLTAGE CONVERSION	7
	2. CYCLE CONVERSION	7
V.	MECHANICAL AND HEAD ADJUSTMENT	8
VI.	ELECTRICAL ADJUSTMENT	8
	1. QUICK REVERSE SENSITIVITY ADJUSTMENT	8
	2. PRE AMPLIFIER ADJUSTMENT	9
	3. DOLBY ADJUSTMENT	10
VII.	CLASSIFICATION OF VARIOUS P.C BOARDS	11
	1. P.C BOARD TITLES AND IDENTIFICATION NUMBERS	11
	2. COMPOSITION OF VARIOUS P.C BOARDS	12

For basic adjustments, measuring methods, and operating principles, refer to GENERAL TECHNICAL MANUAL

I. SPECIFICATIONS

TRACK SYSTEM	4 Track 2 Channel Stereo System
TAPE	Philips Type Cassette
TAPE SPEED	4.76 cm/s $\pm 1.5\%$ (1-7/8 ips. $\pm 1.5\%$)
HEADS	Twin Field Super GX head for recording/playback x 1 Erase head x 2
MOTORS	Electronically speed controlled D.C. motor for capstan drive x 1 D.C. motor for reel drive x 1
WOW & FLUTTER	Less than 0.035% WRMS, 0.11% (DIN 45 500)
TAPE WINDING TIME	80 sec. using a C-60 cassette tape
FREQUENCY RESPONSE	Normal: 25 to 16,000 Hz ± 3 dB (-20 VU). CrO ₂ : 25 to 17,000 Hz ± 3 dB (-20 VU). 25 to 9,000 Hz ± 3 dB (0 VU). Metal: 25 to 19,000 Hz ± 3 dB (-20 VU). 25 to 13,000 Hz ± 3 dB (0 VU).
SIGNAL TO NOISE RATIO	Normal: Better than 58 dB CrO ₂ : Better than 60 dB Metal: Better than 60 dB (measured via tape with peak recording level) Dolby B-type NR switch ON: Improves up to 5 dB at 1 kHz, 10 dB above 5 kHz Dolby C-type NR switch ON: Improves up to 15 dB at 500 Hz, 20 dB at 1 kHz to 10 kHz
HARMONIC DISTORTION	Normal: Less than 0.8% CrO ₂ : Less than 0.7% Metal: Less than 0.7%
INPUT	MIC: 0.25 mV (input impedance 5.0 kohms) Required microphone impedance: 600 ohms Line: 70 mV (input impedance 47 kohms)
OUTPUT	Line: 410 mV at 0 VU Required load impedance: more than 20 kohms Phone: 1.3 mW/8 ohms at 0 VU
DIN	Input: 2.0 mV (input impedance 10 kohms) Output: 410 mV Required load impedance: more than 20 kohms
POWER CONSUMPTION	36 W
POWER REQUIREMENTS	100V, 50/60 Hz for Japan 120V, 60 Hz for USA and Canada 220V, 50 Hz for Europe except UK 240V, 50 Hz for UK and Australia 110V/120V/220V/240V, 50/60 Hz switchable for other countries.
DIMENSIONS	440(W) x 118(H) x 309(D) mm (17.3 x 4.6 x 12.2 inches)
WEIGHT	8.6 kg (19.0 lbs)

* For improvement purposes, specifications and design are subject to change without notice.

* "Dolby" and the Double D symbol are trademarks of Dolby Laboratories.

(Manufactured under license from Dolby Laboratories)

CONTROL 45

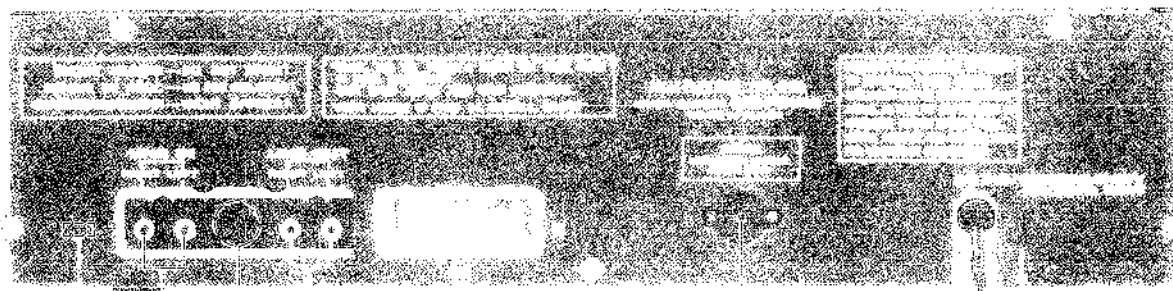
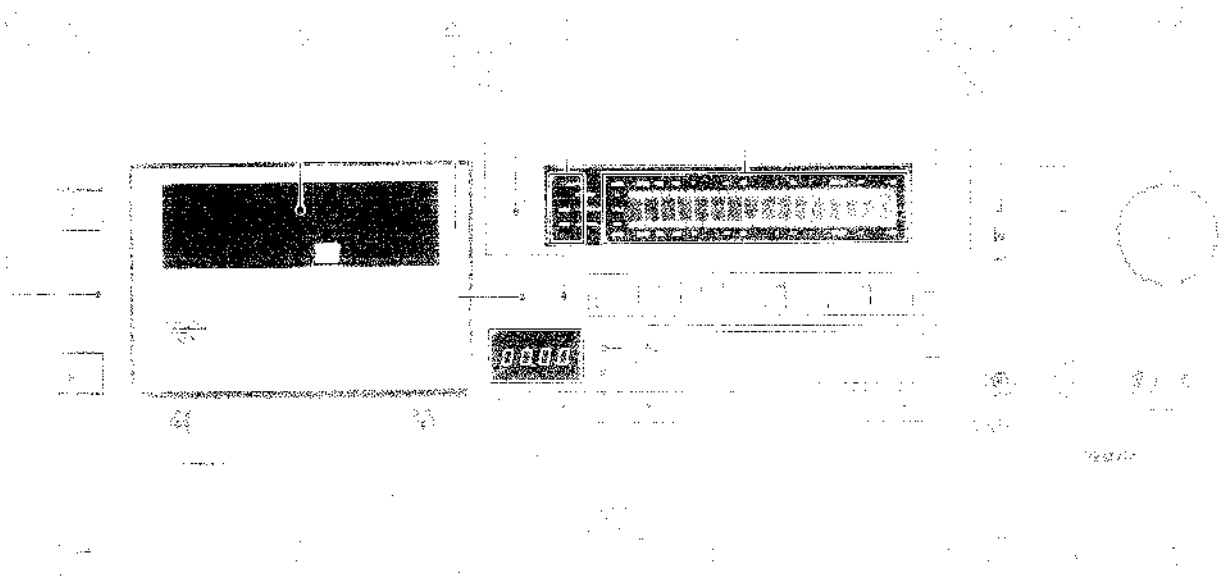

- 1. [Illegible]
- 2. [Illegible]
- 3. [Illegible]
- 4. [Illegible]
- 5. [Illegible]
- 6. [Illegible]
- 7. [Illegible]
- 8. [Illegible]
- 9. [Illegible]
- 10. [Illegible]
- 11. [Illegible]
- 12. [Illegible]
- 13. [Illegible]
- 14. [Illegible]

III PRINCIPAL PARTS LOCATION

TIMER STAT SW. 741 FUSE 742 FUSE 743 FUSE 744 FUSE 745
 FUSE 746 FUSE 747 FUSE 748 FUSE 749 FUSE 750

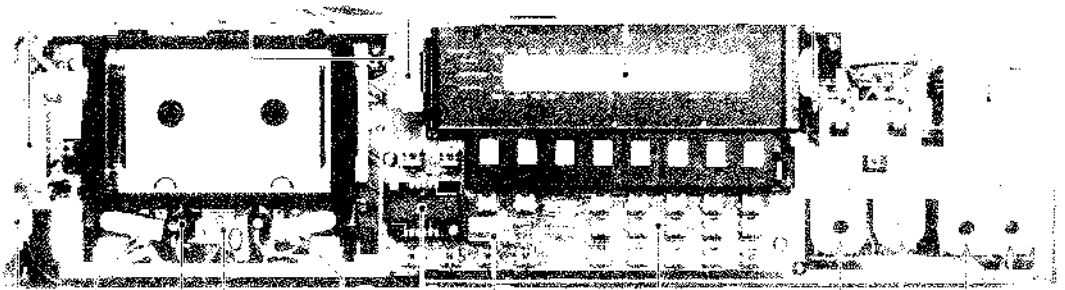

FUSE 751 FUSE 752 FUSE 753 FUSE 754 FUSE 755 FUSE 756
 FUSE 757 FUSE 758 FUSE 759 FUSE 760 FUSE 761 FUSE 762

FUSE 763
 FUSE 764
 FUSE 765
 FUSE 766
 FUSE 767
 FUSE 768
 FUSE 769
 FUSE 770
 FUSE 771
 FUSE 772
 FUSE 773
 FUSE 774
 FUSE 775
 FUSE 776
 FUSE 777
 FUSE 778
 FUSE 779
 FUSE 780
 FUSE 781
 FUSE 782
 FUSE 783
 FUSE 784
 FUSE 785
 FUSE 786
 FUSE 787
 FUSE 788
 FUSE 789
 FUSE 790
 FUSE 791
 FUSE 792
 FUSE 793
 FUSE 794
 FUSE 795
 FUSE 796
 FUSE 797
 FUSE 798
 FUSE 799
 FUSE 800

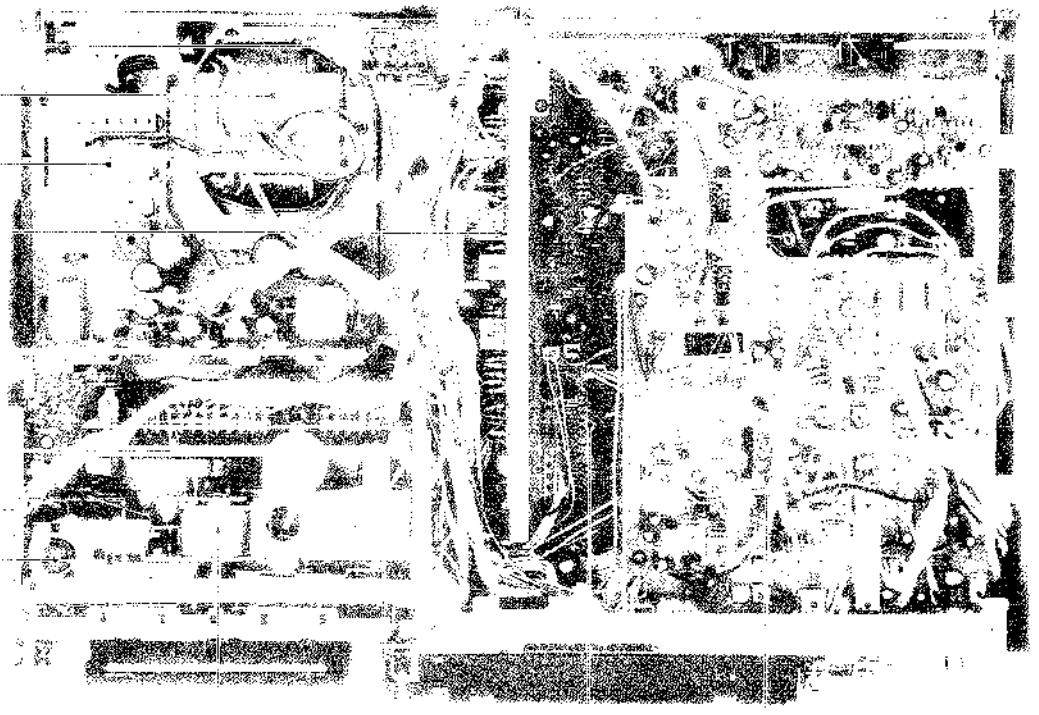
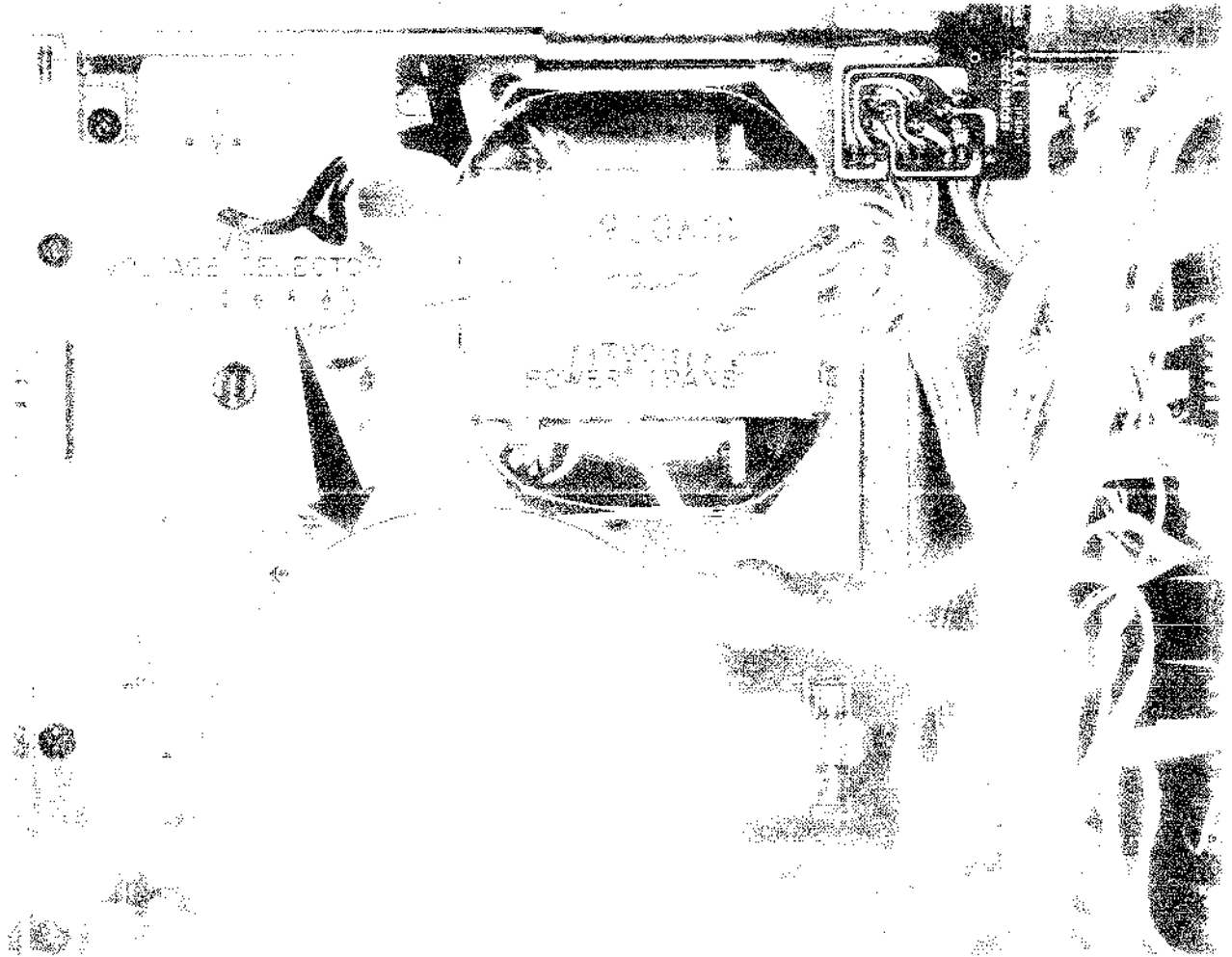

Fig. 3 Top View

14. VOLT TACH AND CYCLE COMPUTER



V. MECHANICAL AND HEAD ADJUSTMENT

REF: 3001-101-01-0001

VI. ELECTRICAL ADJUSTMENT

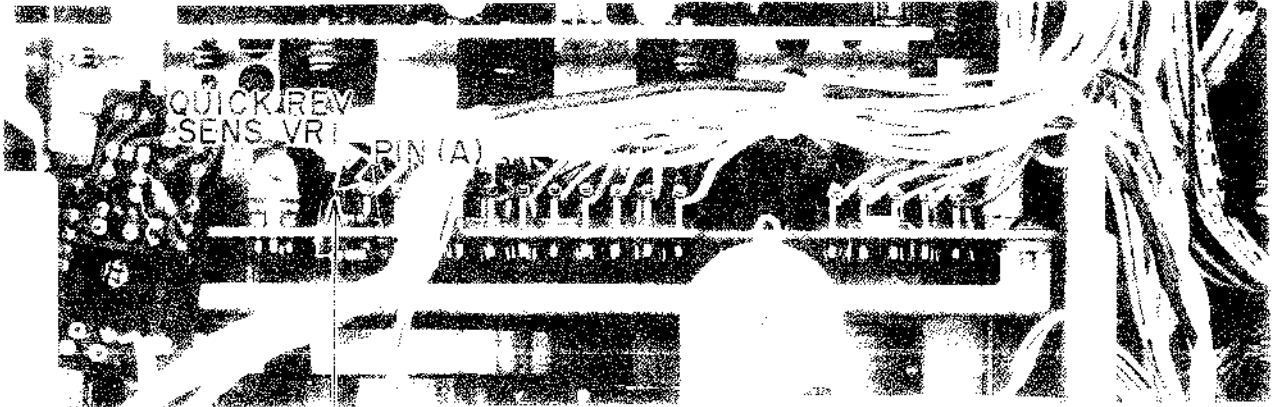

DIGITAL
VOLTMETER

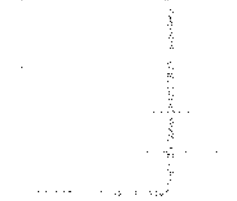

20

3001-101-01-0001

3001-101-01-0001

3001-101-01-0001
3001-101-01-0001
3001-101-01-0001
3001-101-01-0001

3001-101-01-0001
3001-101-01-0001

3001-101-01-0001
3001-101-01-0001

Step	Adjustment Item	Test Tape Supply Signal	Mode	Adjustment Parts	Result	Remarks
4	Normal Position Frequency Response (FWD)	Normal Blank Tape 1 kHz, 10 kHz -25.5 dBm	FWD REC/PB	VC1 Pre Amp PCB	1 kHz to 10 kHz flat response	
5	Normal Position Frequency Response (REV)	Normal Blank Tape 1 kHz, 10 kHz -25.5 dBm	REV REC/PB	VC2 Pre Amp PCB	1 kHz to 10 kHz flat response	
6	CrO ₂ Position Frequency Response	CrO ₂ Blank Tape 1 kHz, 10 kHz -25.5 dBm	FWD/REV REC/PB	VR6 Pre Amp PCB	1 kHz to 10 kHz flat response	
7	Metal Position Frequency Response	Metal Blank Tape 1 kHz, 10 kHz -25.5 dBm	FWD/REV REC/PB	VR5 Pre Amp PCB	1 kHz to 10 kHz flat response	
8	REC Level	Normal Blank Tape 1 kHz, -5.5 dBm	FWD/REV REC/PB	VR4 Pre Amp PCB	-5.5 ± 0.5 dBm (410 mV)	
9	MPX Filter	19 kHz from oscillator	REC	FL4 Dolby (C) PCB	Minimum Output	MPX Filter ON
10	Bias Filter	No Signal Input	REC	FL3 Dolby (C) PCB	Minimum Output	Set REC Volume to maximum
11	VU Meter Sensitivity	1 kHz, -5.5 dBm from oscillator	REC	VR5 Dolby (C) PCB	0 dB (VU) indication	

- NOTES: 1. Output volume should be at maximum.
 2. Dolby NR Switch to OFF Position.
 3. Except for Step 9 set Dolby Filter Switch to OFF Position.

4. Use the following cassette measuring tapes:
 Normal Tape: Maxell UD C-60
 CrO₂ Tape: TDK SA C-60
 Metal Tape: TDK MA-C C-60

3. DOLBY ADJUSTMENT (Refer to Fig. 7 Dolby (C) PCB)

- 1) Set Dolby Switch to C-Type and the set to REC/PAUSE mode.
- 2) Input the signal of 700 Hz from LINE IN and adjust the input level so that TP1 will be 0 dBm (0.775V).
- 3) Adjust VR3 (REC-AS) so that TP-REC will be 0 ± 0.5 dBm.
- 4) Set Dolby Switch to OFF position.
- 5) Input the signal of 700 Hz from LINE IN and adjust the input level so that TP1 will be -30.5 dBm.
- 6) Set Dolby Switch to C-Type.
- 7) Adjust VR4 (BIAS) so that TP-REC will be -19.5 ± 0.3 dBm.
- 8) Set Dolby Switch C-Type and the set to FWD PLAY mode.
- 9) Remove P9 connector (PB INPUT) and input the signal of 700 Hz from there.
- 10) Adjust the input level so that TP2 will be 0 dBm.
- 11) Adjust VR2 (PB-AS) so that TP-PB will be 0 ± 0.5 dBm.

NOTES: 1) For the adjustment, use Audio OSC, AC Voltmeter (mV meter).

2) Adjust both channels at right and left.

VII. CLASSIFICATION OF VARIOUS P.C BOARDS

I. P.C BOARD TITLES AND IDENTIFICATION NUMBERS

P.C BOARD TITLE	P.C BOARD NUMBER
Pre Amp P.C Board	T2023A5010
Dolby (C) P.C Board	T2034A502A
Syscon P.C Board (2)	T2023B5100
Drive P.C Board	T2023C5040
Power Supply P.C Board	T2023B502A
Key Board P.C Board (2)	T2023C511A
Dolby LED P.C Board	T2023B502E
Tape LED P.C Board	T2023B502D
Remote Control P.C Board	T2023B502B
Slide P.C Board	T2023B502F
Reverse P.C Board	T2023D5070
Lamp P.C Board	T2022D5140
Filter P.C Board	CL-5026
LD P.C Board	T2023D5090
Lamp Meter P.C Board	T2023B502C
Memory P.C Board (2)	T2023C511B
Detector P.C Board	T2022D5150
"	CY-0023

2. COMPOSITION OF VARIOUS P.C BOARDS

1) Pre Amp P.C Board T2023A5010 (2ED) and Tape LED P.C Board T2023B502D

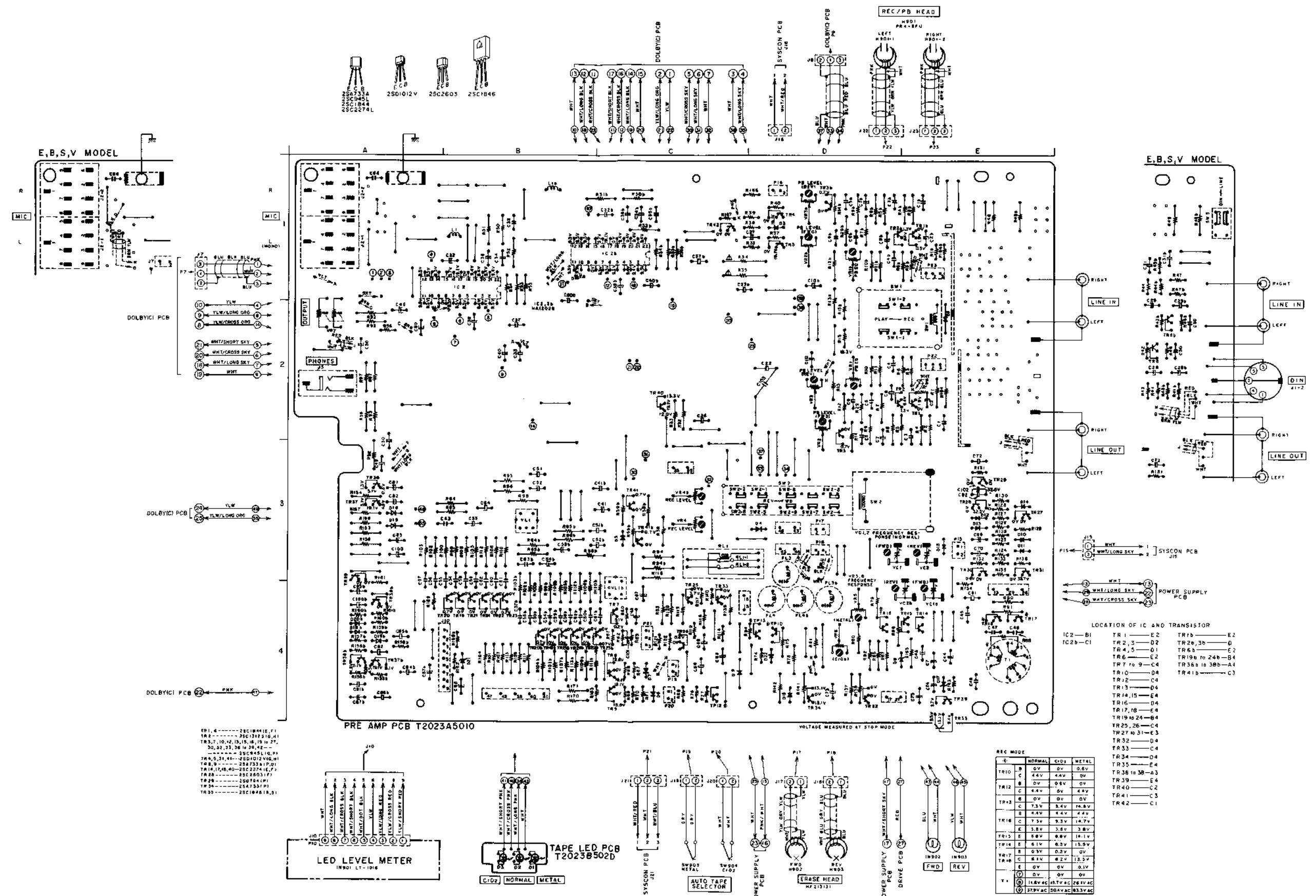

2) Syscon P.C Board (2) T2023B5100, Key Board P.C Board (2) T2023C511A, Remote Control P.C Board T2023B502B, Slide P.C Board T2023B502F, Reverse P.C Board T2023D5070 and Memory P.C Board (2) T2023C511B

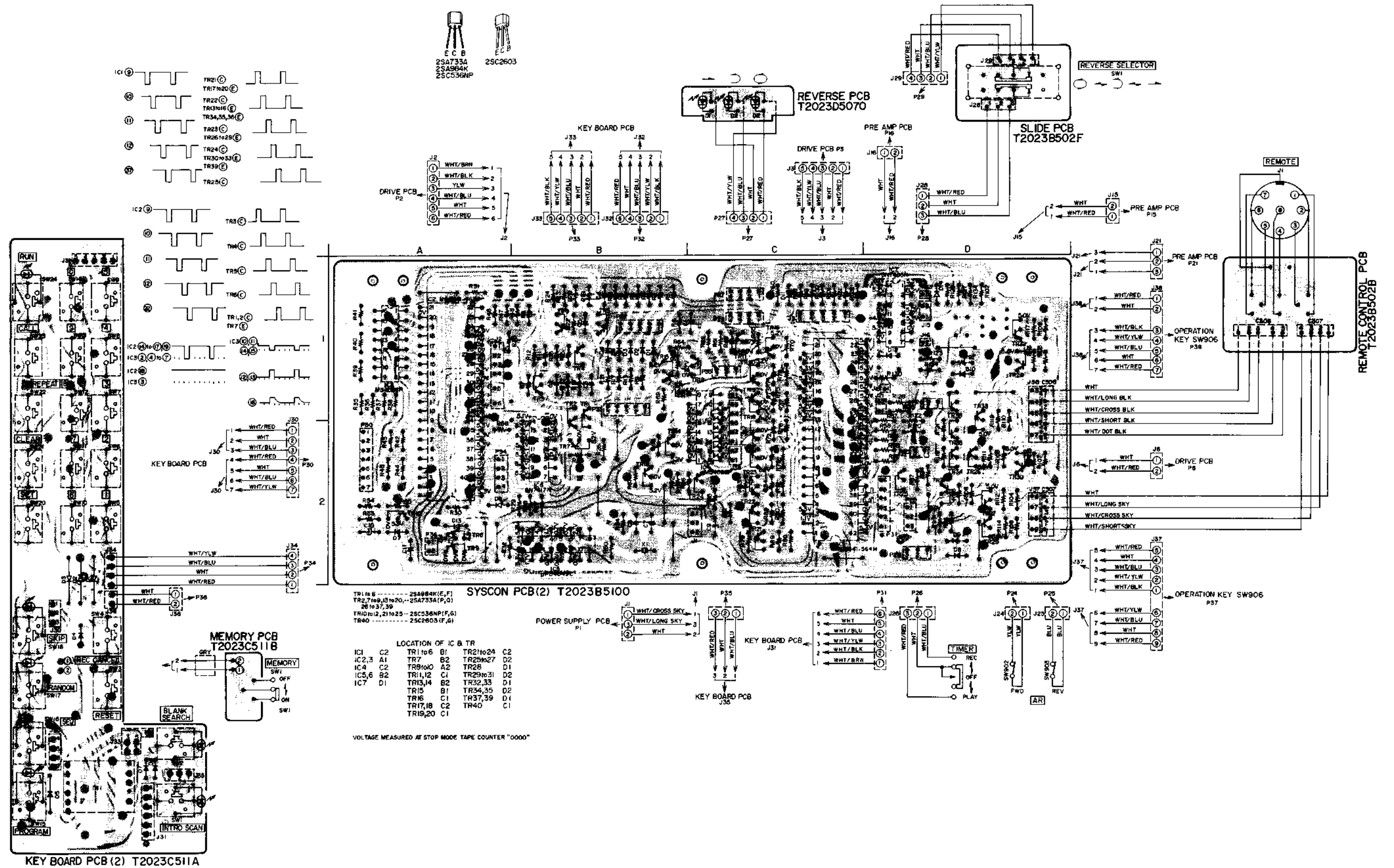

3) Dolby (C) P.C Board T2034A502A, Dolby LED P.C Board T2023B502E and Lamp Meter P.C Board T2023B502C

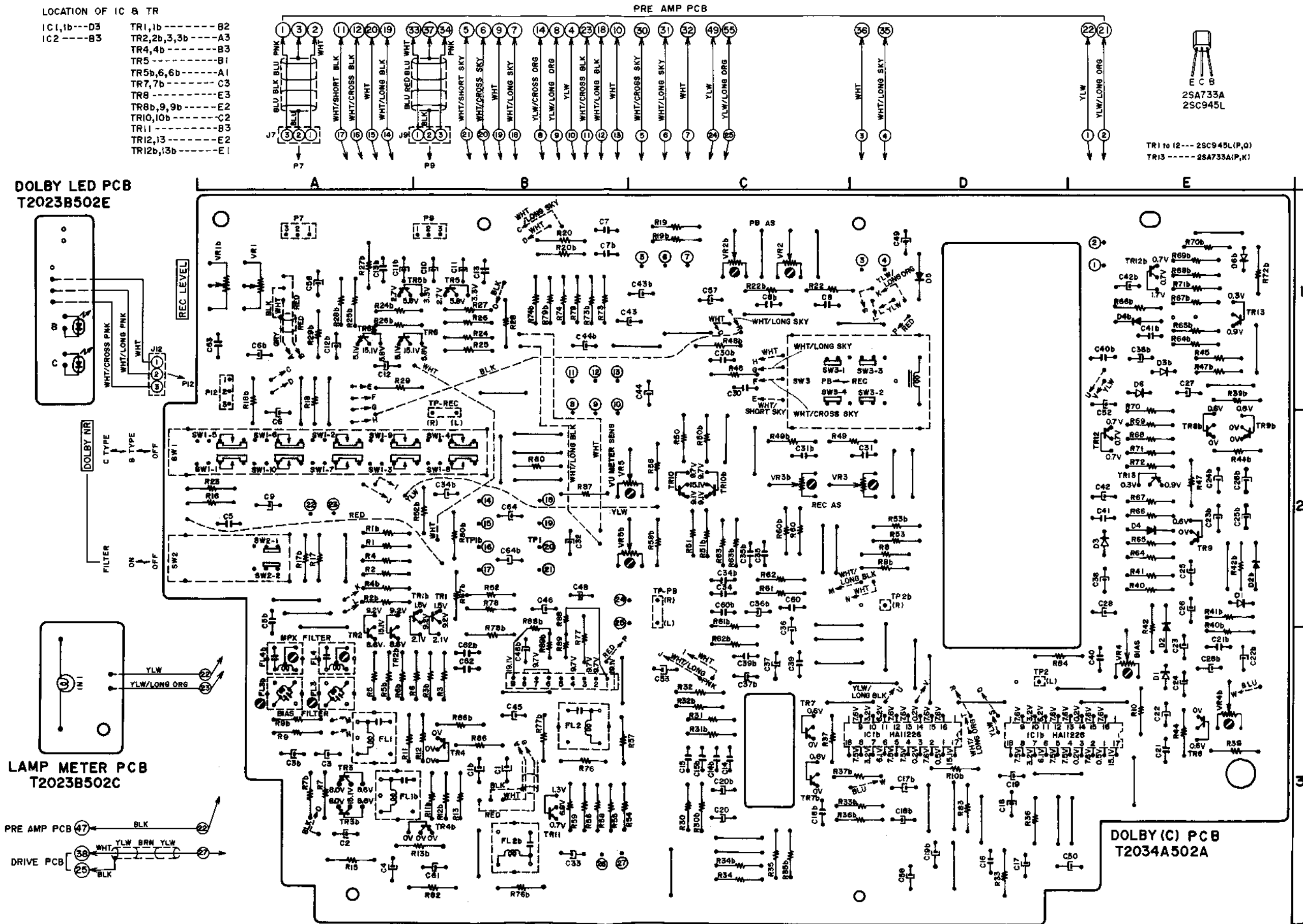

4) Drive P.C Board T2023C5040 (4ED), LED P.C Board T2023D5090 (2ED), Lamp P.C Board T2022D5140, Filter P.C Board CL-5026 (2ED), Detector P.C Board T2022D5150 and Detector P.C Board CY-0023

- TR1,6 -----2SD794(P,Q)
- TR2,7,11 -----2SA984K(E,F)
- TR3,4,8,9,12,13,19 to 29 -----2SC2603(F,G)
- TR5,10,14 -----2SC2274K(E,F)
- TR15,18 -----2SD1012(G,H)
- TR16,17 -----2SB808
- TR30 to 33 -----2SC2603(E,F)
- TR36 -----2SD1012(G,H)

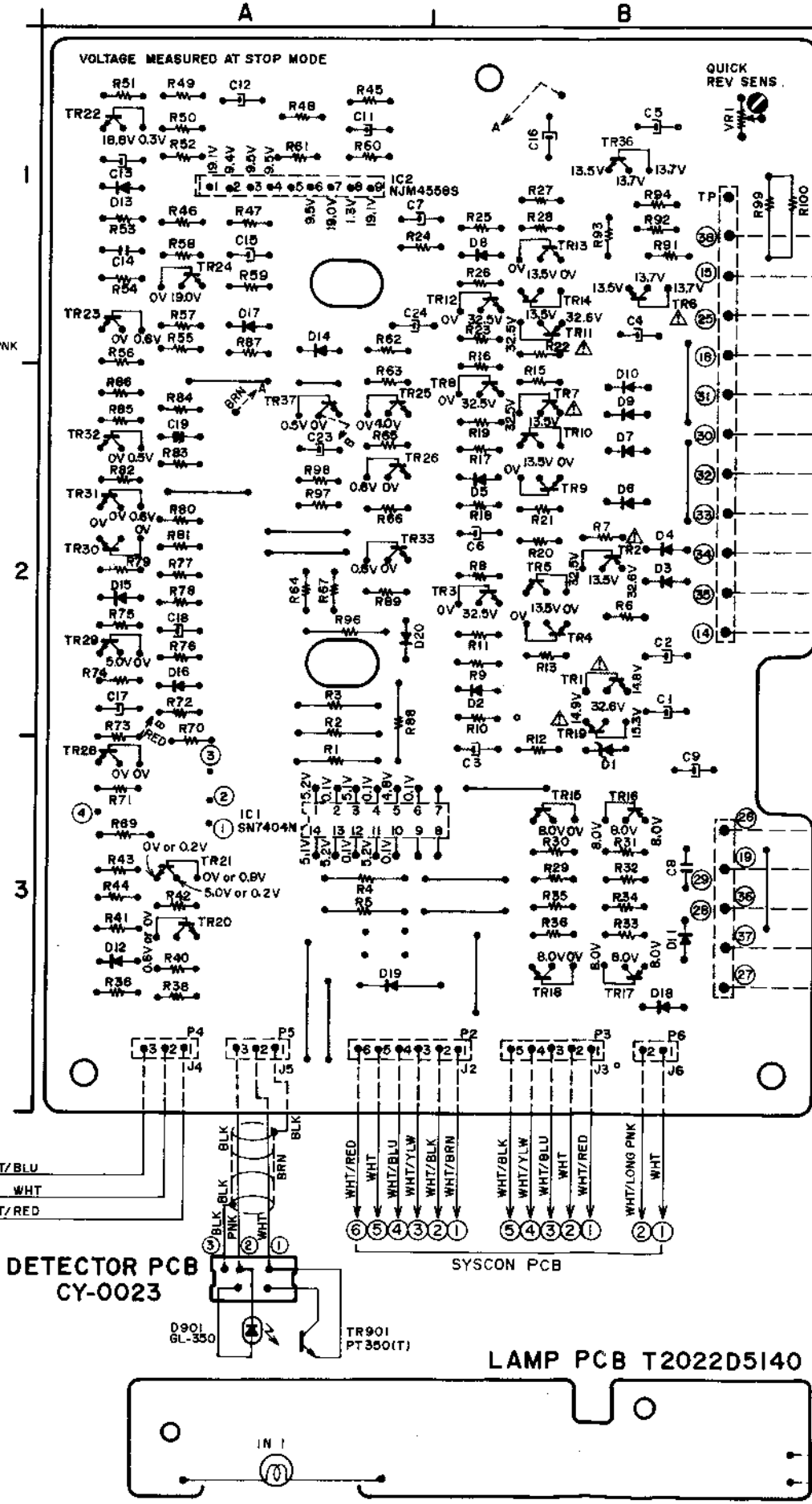
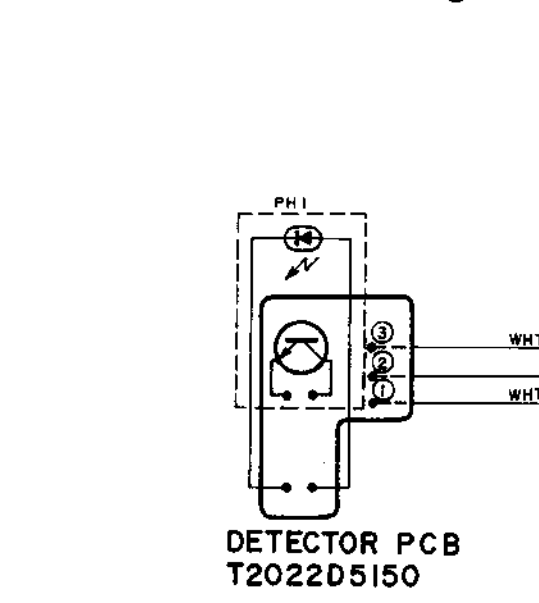
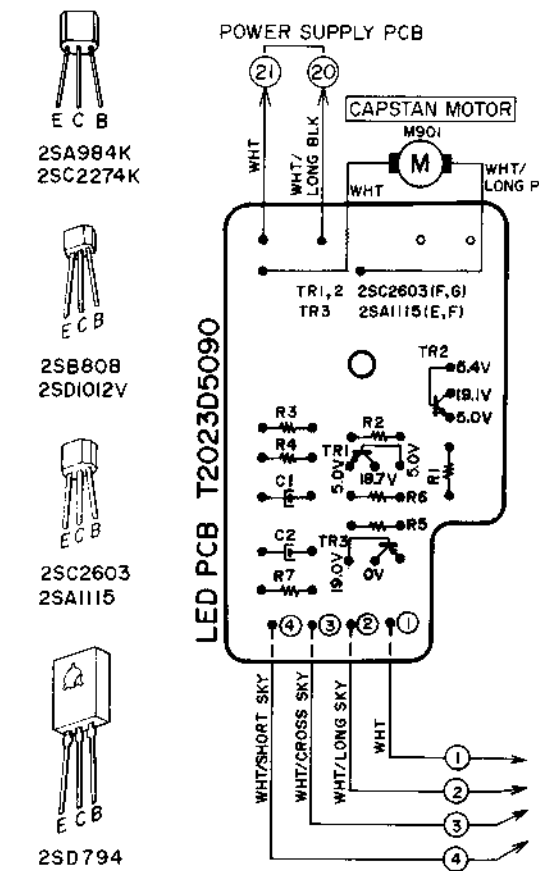

- LOCATION OF IC & TR
- IC 1 -----A3
 - IC 2 -----A1
 - TR1 to 5 -----B2
 - TR6 -----B1
 - TR7 to 10 -----B2
 - TR11 to 14 -----B1
 - TR15 to 18 -----B3
 - TR19 -----B2
 - TR20, 21 -----A3
 - TR22 to 24 -----A1
 - TR25, 26 -----A2
 - TR28 -----A3
 - TR29 to 33 -----A2
 - TR36 -----B1
 - TR37 -----A2

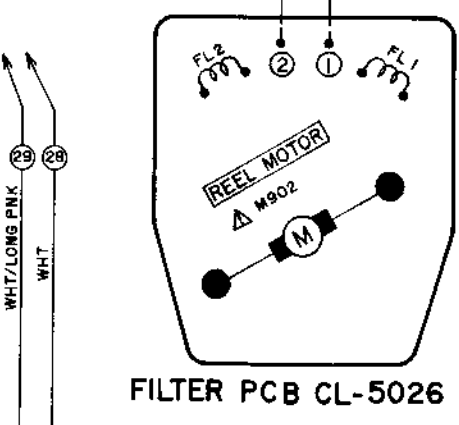
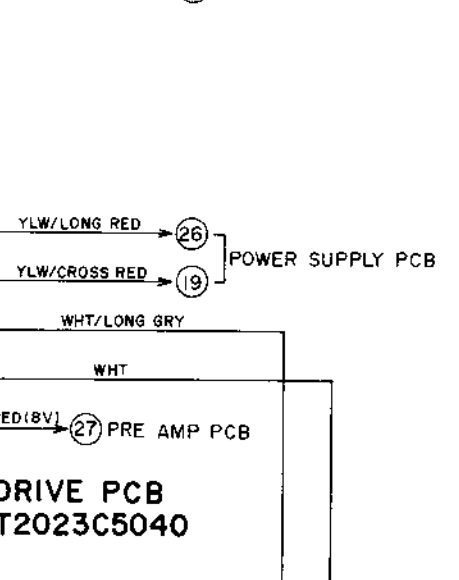
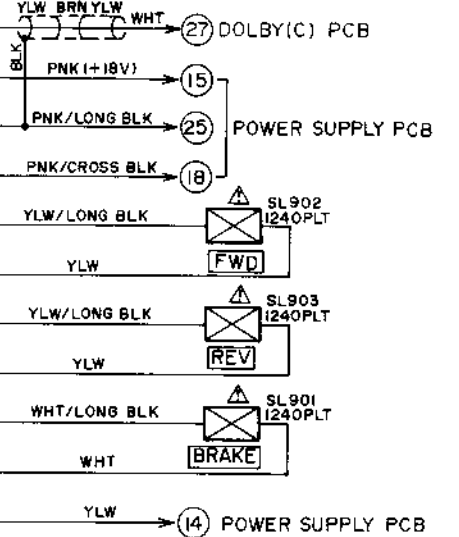

WARNING: Δ INDICATES SAFETY CRITICAL COMPONENTS. FOR CONTINUED SAFETY, REPLACE SAFETY CRITICAL COMPONENTS ONLY WITH MANUFACTURER'S RECOMMENDED PARTS.
 AVERTISSEMENT: Δ IL INDIQUE LES COMPOSANTS CRITIQUES DE SÛRETÉ. POUR MAINTENIR LE DEGRÉ DE SÛRETÉ DE L'APPAREIL, NE REMPLACER LES COMPOSANTS DONT LE FONCTIONNEMENT EST CRITIQUE POUR LA SÛRETÉ QUE PAR DES PIÈCES RECOMMANDÉES PAR LE FABRICANT.

5) Power Supply P.C Board T2023B502A

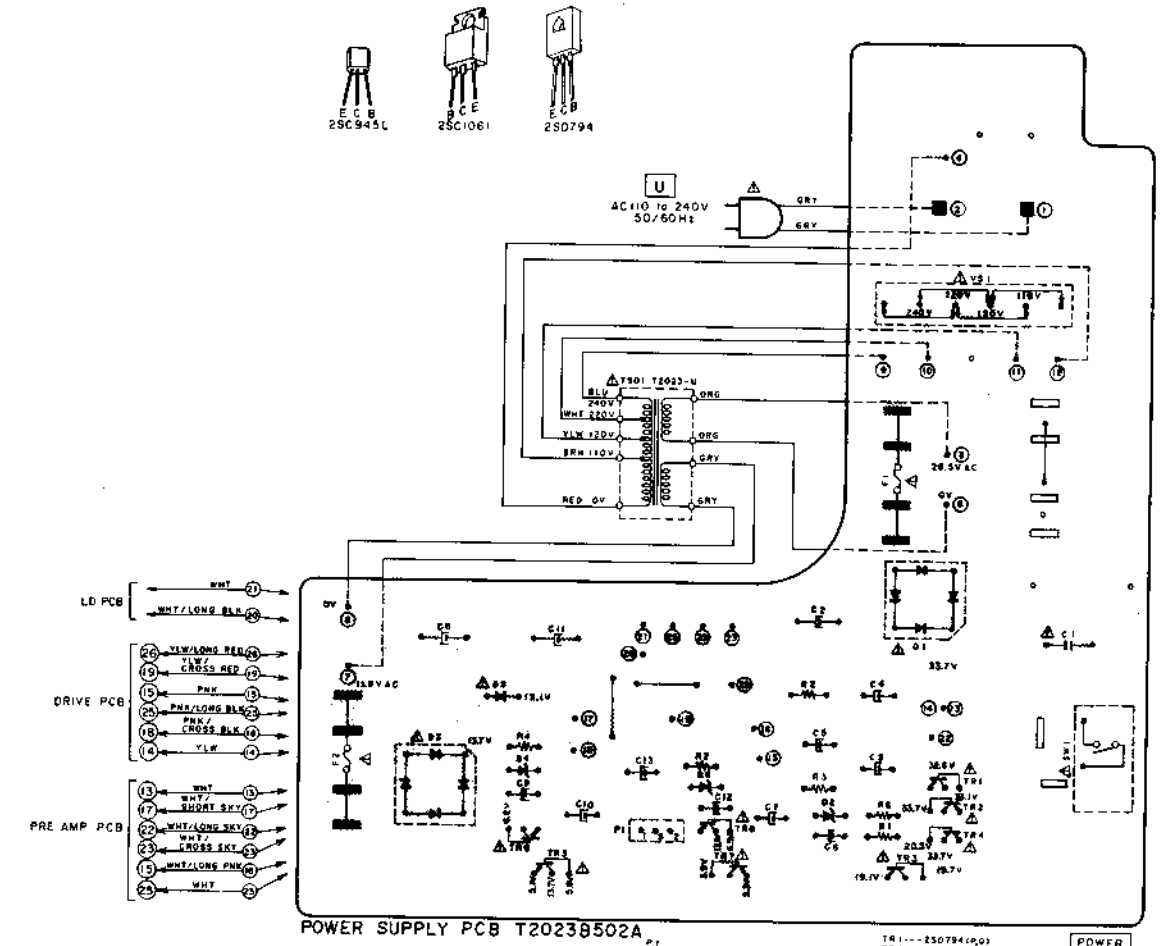

WARNINGS: Δ INDICATES SAFETY CRITICAL COMPONENTS. FOR CONTINUED SAFETY, REPLACE SAFETY CRITICAL COMPONENTS ONLY WITH MANUFACTURER'S RECOMMENDED PARTS.
 AVERTISSEMENT: Δ ILL INDIQUE LES COMPOSANTS CRITIQUES DE SÛRETÉ. POUR MAINTENIR LE DEGRÉ DE SÛRETÉ DE L'APPAREIL, NE REMPLACER LES COMPOSANTS DONT LE FONCTIONNEMENT EST CRITIQUE POUR LA SÛRETÉ QUE PAR DES PIÈCES RECOMMANDÉES PAR LE FABRICANT.

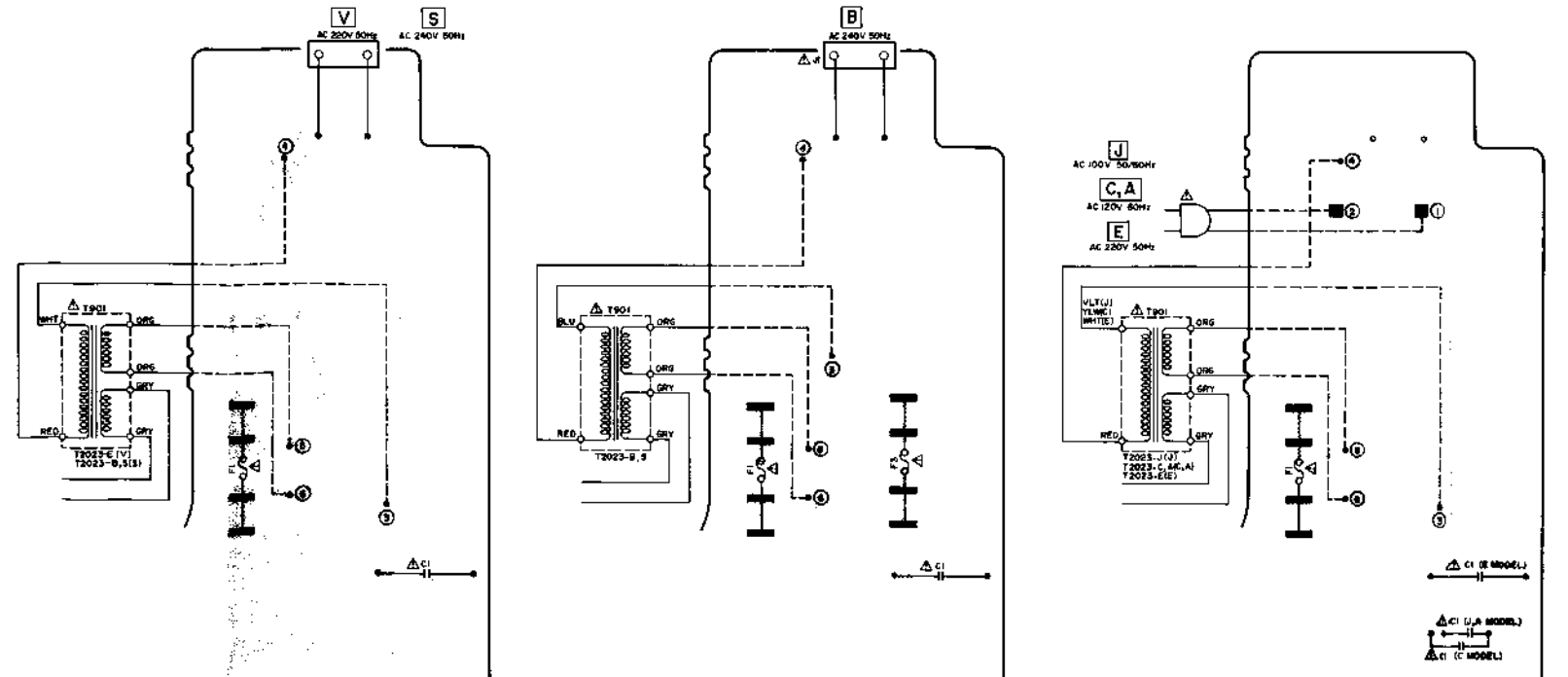

SECTION 2

PARTS LIST

TABLE OF CONTENTS

1. RECOMMENDED SPARE PARTS	21
2. HEAD CASE BLOCK	22
3. REAR PANEL BLOCK	23
4. MOUNTING BRACK	24
5. FRONT P.C. BOARD BLOCK	25
6. SYS. UNIT P.C. BOARD BLOCK	26
7. POWER SUPPLY P.C. BOARD BLOCK	27
8. DISPLAY P.C. BOARD BLOCK	28
9. INPUT KEY P.C. BOARD BLOCK	29
10. KEYBOARD (C) P.C. BOARD BLOCK	30
11. I/O P.C. BOARD BLOCK	31
12. FILTER P.C. BOARD BLOCK	32
13. ASSEMBLY BLOCK	33
14. FINAL ASSEMBLY BLOCK	34
INDEX	35

Resistor and Capacitor which is not listed in this parts list, please refer to COMMON LIST FOR SERVICE PARTS.

HOW TO USE THIS PARTS LIST

1. This parts list is compiled by various individual blocks based on assembly process.
2. When ordering parts, please describe parts number, serial number, and model number in detail.
3. How to read list.

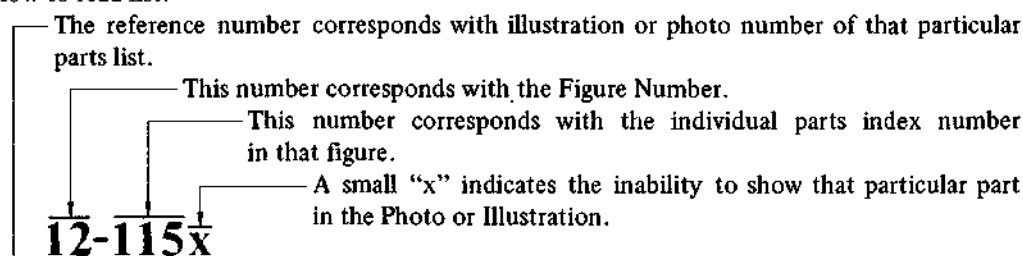

Ref. No.	Parts No.	Description
FLYWHEEL BLOCK #13		
12-115x	800425	Flywheel Block Assy. Comp.
12-116	244506	Flywheel Only
12-117x	244754	Felt, Flywheel
12-118	251324	Main Metal Case
12-119	253080	Main Metal

4. The symbol numbers shown on the P.C. Board list can be matched with the Composite Views of components of the Schematic Diagram of Service Manual.
5. The indications of Resistors and Capacitors in the photos of P.C. Board are being eliminated.
6. The shape of the parts and parts name, etc. can be confirmed by comparing them with the parts shown on the Electrical Parts Table of P.C. Board.
7. Both the kind of part and installation position can be determined by the Parts Number. To determine where a parts number is listed, utilize Parts Index at end of Parts List.
It is necessary first of all to find the Parts Number. This can be accomplished by using the Reference Number listed at right of parts number in the Parts Index. (meaning of ref. no. outlined in Item 3 above).
8. Utilize separate "Price List for Parts" to determine unit price. The most simple method of finding parts Price is to utilize the reference number.

CAUTION:

1. When placing an order for parts, be sure to list the parts no. model no., and description. There are instances in which if any of this information is omitted, parts cannot be shipped or the wrong parts will be delivered.
2. Please be careful not to make a mistake in the parts no. If the parts no. is in error, a part different from the one ordered may be delivered.
3. Because parts number and parts unit supply in the Preliminary Service Manual (Basic Parts List) may be partially changed, please use this parts list for all future reference.

WARNING: Δ INDICATES SAFETY CRITICAL COMPONENTS. FOR CONTINUED SAFETY, REPLACE SAFETY CRITICAL COMPONENTS ONLY WITH MANUFACTURER'S RECOMMENDED PARTS.

AVERTISSEMENT: Δ IL INDIQU LES COMPOSANTS CRITIQUES DE SURETE. POUR MAINTENIR LE DEGRE DE SECURITE DE L'APPAREIL NE REMPLACER LES COMPOSANTS DONT LE FONCTIONNEMENT EST CRITIQUE POUR LA SECURITE QUE PAR DES PIECES RECOMMANDEES PAR LE FABRICANT.

1. RECOMMENDED SPARE PARTS

Because, if the parts listed below are on hand, almost any repair can be accomplished, we suggest that you stock these Recommended Spare Parts Items.

REF. NO.	PARTS NO.	DESCRIPTION	REF. NO.	PARTS NO.	DESCRIPTION
1-1	BHT2023A320A	HEAD BASE BLK GX-F66R	1-64	ES312238	△ SW PUSH SDL-1P 01-1 UC (C,A)
1-2	BI312117	REW IDLER ASSY	1-65	ES330521	SW LEAF BSW-47AB 01-1 NC
1-3	BI312118	TAKE UP IDLER ASSY	1-66	ES330522	SW LEAF BSW-47AC 01-1 NC
1-4	BMT2022A080A	△ MOTOR (PULLEY) BLK CS-F33R	1-67	ES332448	SW LEVER 01030123 2-10-03N
1-5	BM314843	△ MOTOR EG-510ED-2F	1-68	ES336779	SW LEVER 2-02-02S
1-6	BM328441	△ MOTOR RF-510T(12620)	1-69	ES283072	SW SLIDE SSC22LP 2-02-02N (E, B, S, V)
1-7	BMT2016A320A	△ REEL MOTOR BLK (W/PULLEY) GX-F35	1-70	ES201527	SW SLIDE SSS212 1-01-02N
1-8	BR328424	TAKE-UP REEL TABLE ASSY	1-71	ES337322	SW SLIDE 00230699 2-02-03N
1-9	BT331665	△ TRANS POWER T2023-C,A (C,A,V)	1-72	ES311975	SW SOLENOID R8150050 27V 10-2W
1-10	BT331663	△ TRANS POWER T2023-J	1-73	ES328415	SW SOLENOID SWE018401 18V 04-2S
1-11	BT331662	△ TRANS POWER T2023-U	1-74	ES328530	SW SOLENOID SWE018404 18V 04-2N
1-12	BT331666	TRANS POWER T2023-B,S	1-75	ES323367	SW TACT KEC10001
1-13	BT331664	TRANS POWER T2023-E	1-76	ES324677	SW TACT KEC11904
1-14	EC315346	C S-FIX H ECV-1ZW50x32E 5.0-55	1-77	ET311977	PHOTO SENSOR SPI-201
1-15	ED308953	D GERMA H 1K34A-LH SNP	1-78	ET200558	TR 2SA1115 E,F
1-16	ED308952	D GERMA V 1K34A-LR F07	1-79	ET336735	TR 2SA733(A) P,K
1-17	ED331227	D GERMA V 1K34A-UF SNP	1-80	ET539133	TR 2SA733A P
1-18	ED322982	D GERMA V 1S188FM-1-LR F07	1-81	ET554657	TR 2SA733A P,Q
1-19	ED322773	D LED SLP-255D-01 GRN	1-82	ET324134	TR 2SA984K E,F
1-20	ED624903	D SILICON H 1S2473	1-83	ET328438	TR 2SB808-V F, G
1-21	ED316143	D SILICON H 1S2473HS F10	1-84	ET375603	TR 2SC1061 B,C
1-22	ED560913	D SILICON V 1S2473VE	1-85	ET603257	TR 2SC1312S G,H
1-23	ED306109	D SILICON W03B 100/1.0A	1-86	ET308954	TR 2SC1844 E,F
1-24	ED319463	D SILICON 4B4B41 100/4.0A	1-87	ET310920	TR 2SC1846 R,S
1-25	ED328486	D ZENER H HZ15 3	1-88	ET309353	TR 2SC2274 E, F
1-26	ED324013	D ZENER H HZ20 2	1-89	ET200506	TR 2SC2603 F
1-27	ED331626	D ZENER H HZ3 B2	1-90	ET200985	TR 2SC2603 F,G
1-28	ED305704	D ZENER H HZ4 B2	1-91	ET635231	TR 2SC536NP F,G
1-29	ED319167	D ZENER H HZ6 C3	1-92	ET639437	TR 2SC945L Q,P
1-30	ED331667	D ZENER H HZ7 A1	1-93	ET328868	TR 2SD1012-V G,H
1-31	ED306014	D ZENER H HZ9 C3	1-94	ET666404	TR 2SD571 K,L
1-32	ED331263	IND LE LT-1016 GRAPH	1-95	ET332245	TR 2SD794 P
1-33	EF593706	△ FUSE SEMKO T 250V 0.50A (F3) (B)	1-96	ET307349	TR 2SD794 P,Q
1-34	EF601301	△ FUSE SEMKO T 250V 2A (F1,2) (E, B, S, V)	1-97	ET307349	TR 2SD794 P,Q
1-35	EF306950	△ FUSE TSC A 250V 2A (F1,2) (U,J)	1-98	EV316442	R S-FIX H D8 3P 102
1-36	EF306954	△ FUSE TSC 125V 2A (F1,2) (C,A)	1-99	EV315542	R S-FIX H D8 3P 103
1-37	EI336737	IC HA11226	1-100	EV322411	R S-FIX H D8 3P 202
1-38	EI336761	IC LA6458S	1-101	EV315753	R S-FIX H D8 3P 203
1-39	EI331658	IC MB8841-461M	1-102	EV315540	R S-FIX H D8 3P 502
1-40	EI336801	IC MB8841-564M	1-103	EV315541	R S-FIX H D8 3P 503
1-41	EI331659	IC M54528P	1-104	EV522652	R S-FIX V V8K1-1 3P 105
1-42	EI201940	IC NJM4558S	1-105	EV202110	VR ROTARY 16P11x0S A503 A503
1-43	EI302681	IC SN7404N	1-106	EV313538	VR ROTARY 16P20x1B B103
1-44	EI331661	IC SN7405N	1-107	HE325859	HEAD E HF213131 C
1-45	EI331660	IC SN7417N	1-108	HPH2206A010A	HEAD R/P PR4-8FU C
1-46	EI319555	IC μPD4049C	1-109	MB314317	BELT CAPSTAN
1-47	EJ310567	△ SOCKET INLET 0378PC-GS E 2P (B, S, V)	1-110	MB314722	BELT COUNTER
1-48	EJ321328	PHONE J HLJ0345-010 2x3P (P)	1-111	MIB601782	FLYWHEEL (A) PART
1-49	EJ337622	PHONE J THROW HLJ0345-210 3P 2x3P	1-112	MIB601783	FLYWHEEL (B) PART
1-50	EJ330545	PHONE J 3P HLJ0315-020 6.3 (P)	1-113	MV328322	MAIN CASE
1-51	EJ337623	PHONE J 3P HLJ0315-023 6.3	1-114	MZ283140	△ SOCKET SELECTOR X-17238 6P (U)
1-52	EL309960	PL CORD 24.0V 50mA 450/450	1-115	TCT2010D090A	PINCH ROLLER (L) BLK CS-M40R
1-53	EL304025	PL H LEAD 10V 110mA	1-116	TCT2010D100A	PINCH ROLLER (R) BLK CS-M40R
1-54	EL317599	PL H LEAD 6.3V 100mA			
1-55	EL300186	PL LEAD 8V 60mA			
1-56	EM331669	IND LE SL-1003 CHARACTER			
1-57	EP318644	△ SOLENOID 1240PLT 27V			
1-58	EP318645	△ SOLENOID 1240PLT 27V			
1-59	EP328529	RELAY LEAD LAB2NS 2NO 12V			
1-60	ER328490	FILTER DB D07-001K 19KHz			
1-61	ER328491	FILTER DB D07-003K 100KHz			
1-62	ES312234	△ SW PUSH SDL-1P 01-1 E (U, E, B, S, V)			
1-63	ES312235	△ SW PUSH SDL-1P 01-1 J (J)			

HEAD BASE BLOCK

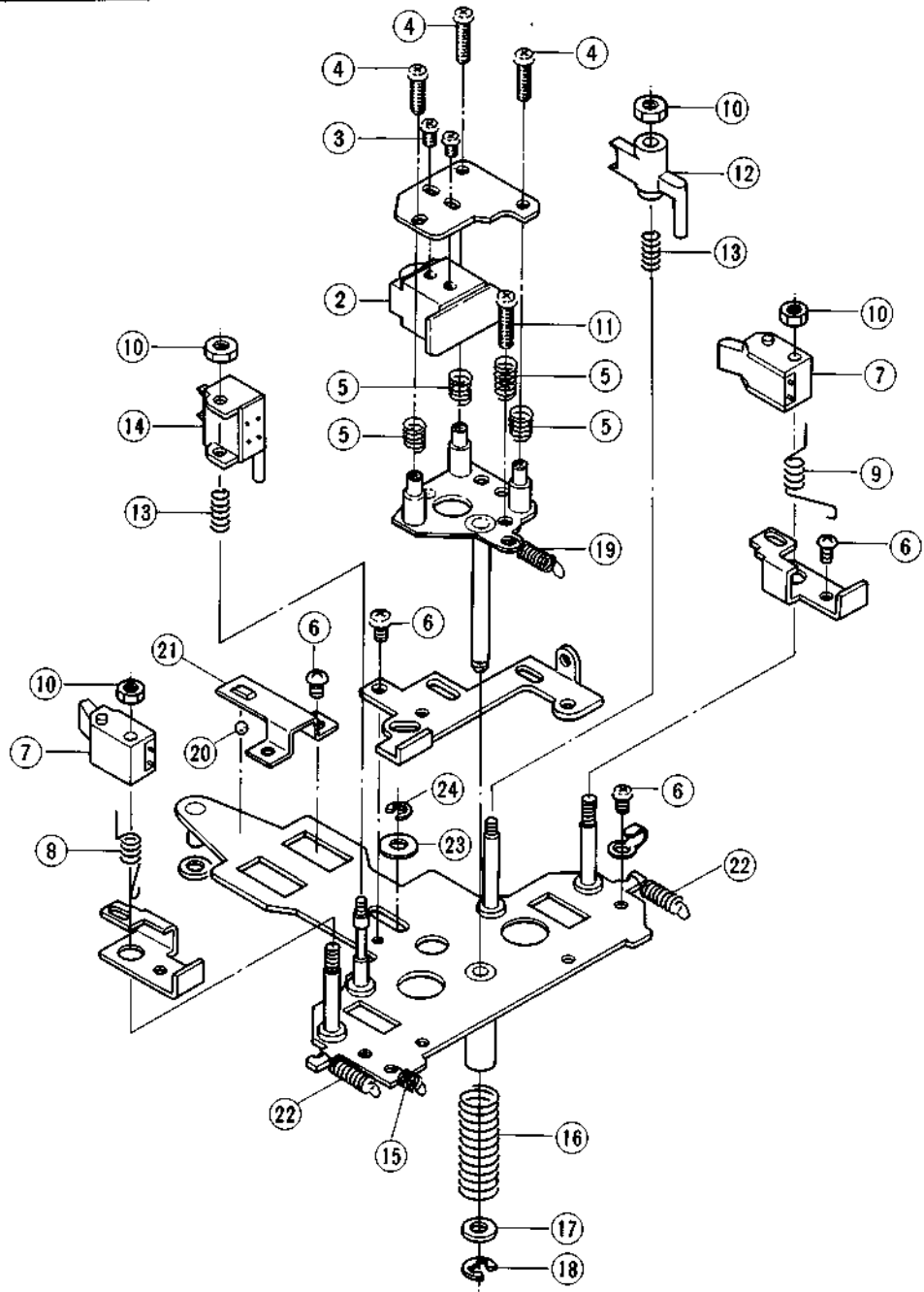

2. HEAD BASE BLOCK

REF. NO.	PARTS NO.	DESCRIPTION	REF. NO.	PARTS NO.	DESCRIPTION
2-1x	BHT2023A320A	HEAD BASE BLK GX-F66R	2-14	BZT2010A070A	DETECTION TAPE GUIDE BLK CS-M40R
2-2	HPH2206A010A	HEAD R/P PR4-8FU C	2-15	ZG312921	SP T1-3.2/0.29-9.0 T1-038
2-3	ZS477876	PAN20x03STL CMT	2-16	ZG313960	SP PUSH
2-4	ZS536488	BID20x08STL CMT	2-17	ZW556828	PW32x100x050STL CMT
2-5	ZG402895	CS ANGLE ADJUST SPRING	2-18	ZW270088	RING E 190SUP CMT
2-6	ZS592378	PAN26x03STL CMT	2-19	ZG402895	CS ANGLE ADJUST SPRING
2-7	HE325859	HEAD E HF213131 C			
2-8	ZG313316	ERASE HEAD SPRING (A)	2-20	MV357208	BALL200STL
2-9	ZG313874	ERASE HEAD SPRING (B)	2-21	MH314340	HEAD HOLDER
2-10	ZW273734	N20BRS NI3 1	2-22	ZG312946	SP T1-3.2/0.29-16.0 T1-062
2-11	ZS465298	PAN23x10STL CMT	2-23	ZW328682	PW31x070x050PBR
2-12	HZ313313	TAPE GUIDE	2-24	ZW270088	RING E 190SUP CMT
2-13	ZG313314	ADJUST SPRING			

When ordering parts, please quote Parts Number, Description and Model Number.

REEL TABLE BLOCK

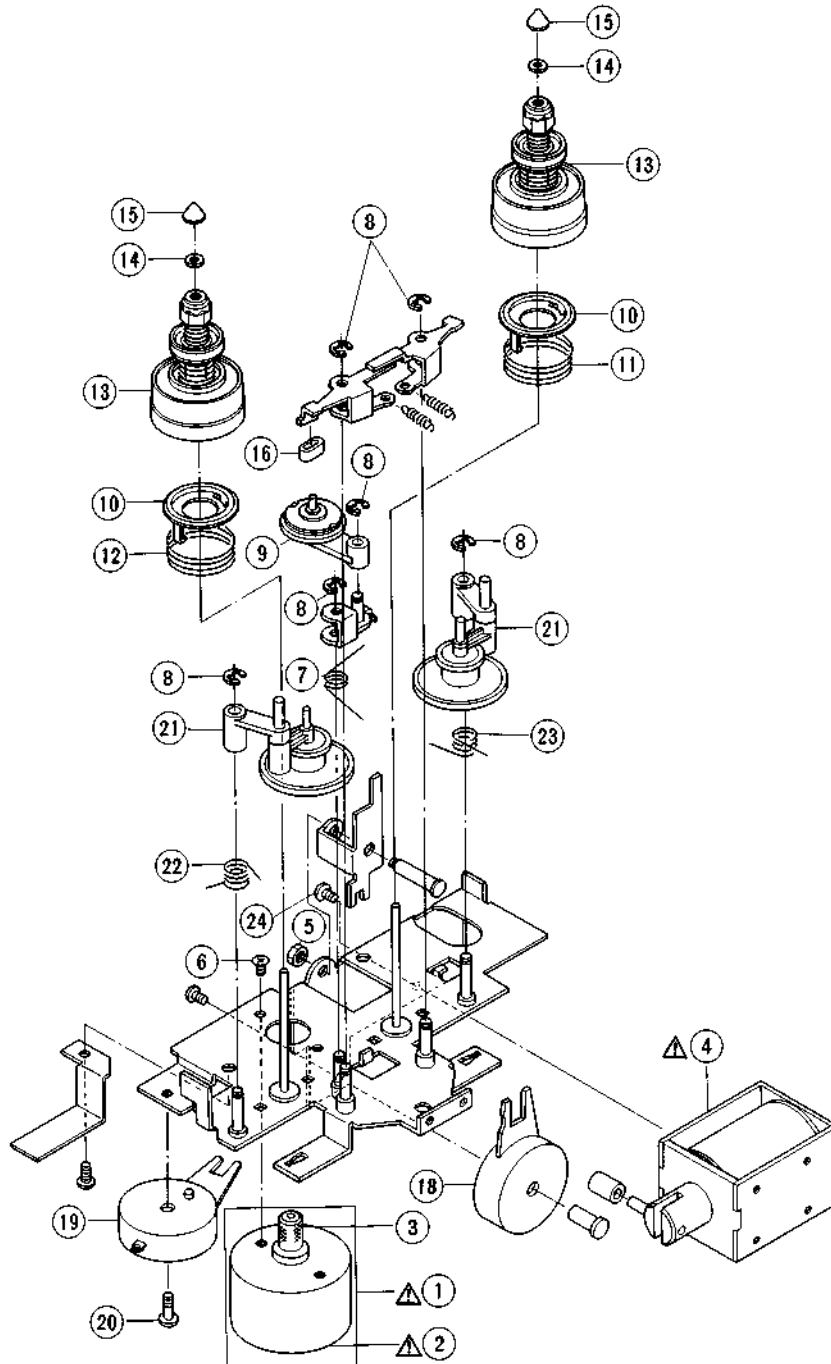

3. REEL TABLE BLOCK

REF. NO.	PARTS NO.	DESCRIPTION	REF. NO.	PARTS NO.	DESCRIPTION
REEL MOTOR BLOCK			3-10	TC328365	BT DRUM
3-1	BMT2016A320A Δ	REEL MOTOR BLK (W/PULLEY) GX-F35	3-11	ZG328366	BT SPRING
3-2	BM328441 Δ	MOTOR RF-510T (12620)	3-12	ZG330049	SP PUSH BACK TENSION
3-3	MR328360	REEL MOTOR PULLEY	3-13	BR328424	TAKE-UP REEL TABLE ASSY
PLUNGER BLOCK			3-14	ZW330073	PW21x040x020
3-4	EP318645 Δ	SOLENOID 1240PLT 27V (SL901)	3-15	MT305793	REEL CAP
REEL TABLE BLOCK			3-16	MB282104	BRAKE RUBBER
3-5	ZW516993	N30STL CMT 1	3-17	ZG321534	SP T2-3.2/0.29-12.5 T2-060
3-6	ZS430413	CTS26x04STL CMT	3-18	BZT2022A260A	DAMPER (C) ASSY CS-F33R
3-7	ZG314747	SP TORSION IDLER	3-19	BZT2016A330A	DAMPER (B) ASSY GX-F35
3-8	ZW270088	RING E 190SUP CMT	3-20	ZS479474	PAN26x05STL CMT
3-9	BI312117	REW IDLER ASSY	3-21	BI312118	TAKE UP IDLER ASSY
			3-22	ZG314876	SP TORSION IDLER CLAMP (A)
			3-23	ZG314749	SP TORSION IDLER CLAMP (B)
			3-24	ZS417137	BID30x04STL CMT

When ordering parts, please quote Parts Number, Description and Model Number.

MECHA FRAME BLOCK

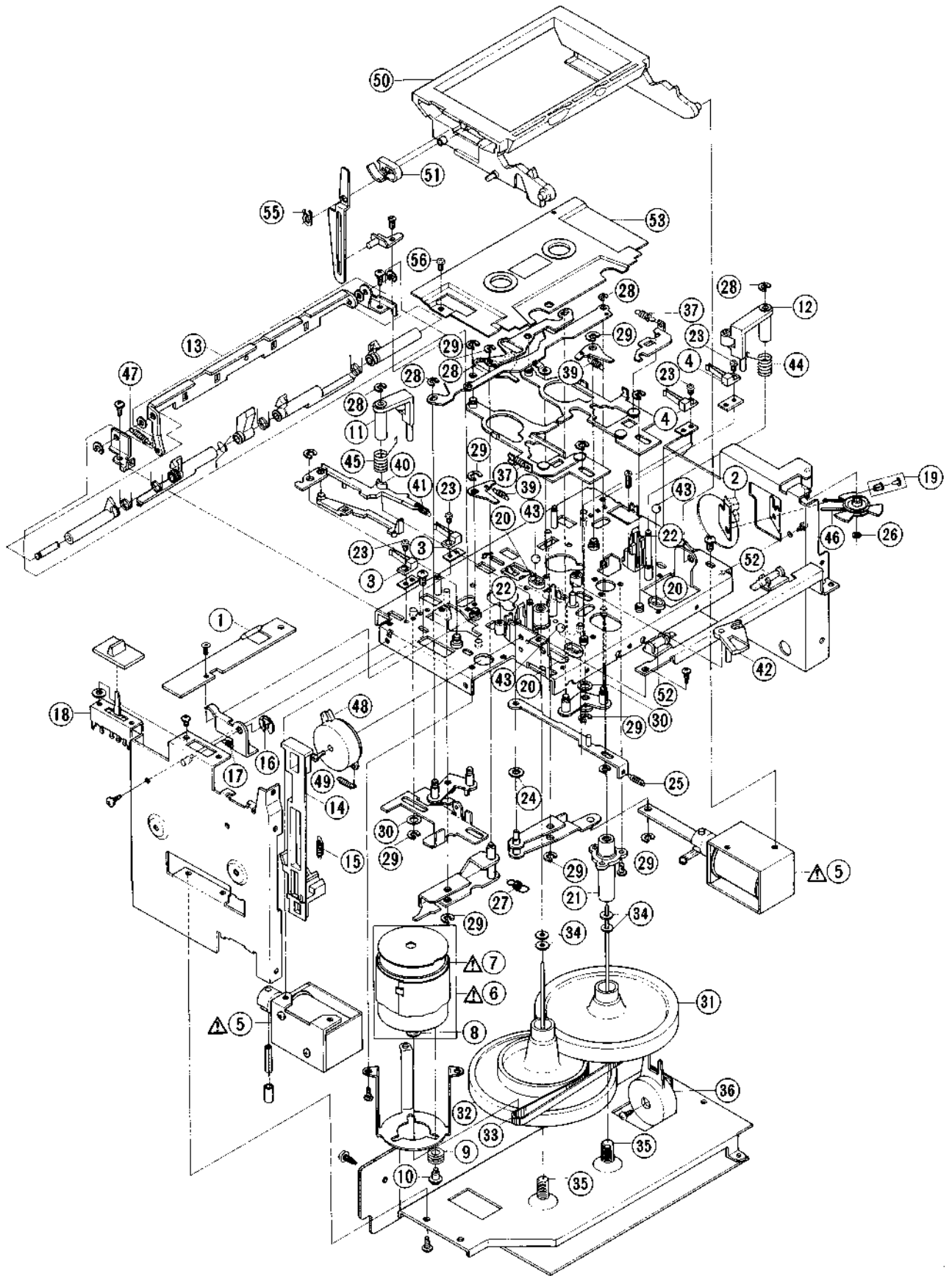

4. MECHA FRAME BLOCK

REF. NO.	PARTS NO.	DESCRIPTION	REF. NO.	PARTS NO.	DESCRIPTION
LAMP P.C BOARD BLOCK					
4-1	EL317599	PL H LEAD 6.3V 100mA (IN1)	4-49	ZG324329	SP T2-3.2/0.29-11.2 T2-059
DETECTION P.C BOARD BLOCK					
4-2	ET311977	PHOTO SENSOR SPI-201 (PH1)	4-50	TC-328351	CASSETTE HOLDER (BL)
SW LEAF (A), (D) BLOCK					
4-3	ES330521	SW LEAF BSW-47AB 01-1 NC (SW902, 904)	4-51	ZG321487	MOLD SPRING
SW LEAF (B), (C) BLOCK					
4-4	ES330522	SW LEAF BSW-47AC 01-1 NC (SW903, 905)	4-52	EL309960	PL CORD 24.0V 50mA 450/450
PLUNGER ASSY					
4-5	EP318644	△ SOLENOID 1240PLT 27V (SL902, 903)	4-53	SZB314713A	LID DECORATION PART
MOTOR BLOCK					
4-6	BMT2022A080A	△ MOTOR (PULLEY) BLK CS-F33R	4-54x	SZB314713B	LID DECORATION (BL) PART
4-7	BM314843	△ MOTOR EG-510ED-2F	4-55	ZW332843	RING GRIP 380STL ACP
4-8	MR328479	MOTOR PULLEY	4-56	ZS432843	PAN26x04STL CMT
4-9	MB282778	RUBBER BUSH			
4-10	ZS321338	MOTOR SCREW			
PINCH ROLLER (L) BLOCK					
4-11	TCT2010D090A	PINCH ROLLER (L) BLK CS-M40R			
PINCH ROLLER (R) BLOCK					
4-12	TCT2010D100A	PINCH ROLLER (R) BLK CS-M40R			
LEVER EJECT BLOCK					
4-13	BZT2023A310A	LEVER EJECT BLK GX-F66R			
CHASSIS (L) BLOCK					
4-14	ML314151	LEVER JOINT			
4-15	ZG318204	SP T2-3.2/0.29-16 T2-062			
4-16	ZW270101	RING E300SUP CMT			
4-17	ZG312944	SP T1-3.2/0.29-12.5 T1-060			
SW SLIDE BLOCK					
4-18	ES330463	SW SLIDE 00230593 2-02-03S (SW901)			
MECHA FRAME BLOCK					
4-19	ZW312121	RV NYL26x042 BL			
4-20	MS302191	BALL GUIDE			
4-21	MV328322	MAIN CASE			
4-22	TC314156	HOLDER CASSETTE			
4-23	ZS460438	BID20x03STL CMT			
4-24	ZW438928	PW31x048x020PBR			
4-25	ZG312942	SP T1-3.2/0.29-10.0 T1-058			
4-26	ZW321437	PUSH WASHER			
4-27	ZG336651	SP PULL PLAY LEVER (A)			
4-28	ZW270088	RING E 190SUP CMT			
4-29	ZW270101	RING E300SUP CMT			
4-30	ZW649991	PW41x070x030PBR			
4-31	MIB601782	FLYWHEEL (A) PART			
4-32	MIB601783	FLYWHEEL (B) PART			
4-33	MB314317	BELT CAPSTAN			
4-34	ZW694798	PW31x070x020TFL			
4-35	ZS302318	HOLD SCREW			
4-36	BZT2016A330A	DAMPER (B) ASSY GX-F35			
4-37	ZG318083	SP PULL CLAMP			
4-38x	HZ314069	SP PLATE HEAD BASE			
4-39	ZG310531	SP T1-4.0/0.4-12.5 T1-109			
4-40	ML314337	LEVER EJECT CHECK			
4-41	ZG312921	SP T1-3.2/0.2-9.0 T1-038			
4-42	MR314339	CAM HEAD CHANGE			
4-43	MV269965	BALL 400STL			
4-44	ZG310694	PINCH ROLLER RETURN SPRING (A)			
4-45	ZG310695	PINCH ROLLER RETURN SPRING (B)			
4-46	MB314722	BELT COUNTER			
4-47	ZG336064	SP PULL EJECT			
4-48	BZT2021A200A	DAMPER (A) BLK CS-F330			

5. PRE AMP P.C BOARD BLOCK

REF. NO.	PARTS NO.	DESCRIPTION
5-1	BAT2040A080A	PC PRE AMP BLK GX-F66RC(U) (U, J, C, A)
5-2	BAT2040A080B	PC PRE AMP BLK GX-F66RC(E) (E, B, S, V)
5-3	BAT2040A080C	PC PRE AMP BLK GX-F66RCP(U) (U, J, C, A)
5-4	BAT2040A080D	PC PRE AMP BLK GX-F66RCP(E) (E, B, S, V)
5-IC2	EI311959	IC HA12028
5-TR1	ET308954	TR 2SC1844 E, F
5-TR2	ET603257	△ TR 2SC1312S G, H
5-TR3	ET639437	TR 2SC945L Q, P
5-TR4,5	ET328868	TR 2SD1012-V G, H
5-TR6	ET308954	TR 2SC1844 E, F (E, B, S, V)
5-TR7	ET639437	TR 2SC945L Q, P
5-TR8,9	ET554657	TR 2SA733A P, Q
5-TR10	ET639437	TR 2SC945L Q, P
5-TR12,13	ET639437	TR 2SC945L Q, P
5-TR14	ET309353	△ TR 2SC2274 E, F
5-TR15,16	ET639437	TR 2SC945L Q, P
5-TR17,18	ET309353	△ TR 2SC2274 E, F
5-TR19to27	ET639437	TR 2SC945L Q, P
5-TR28	ET200506	TR 2SC2603 F
5-TR29	ET332245	TR 2SD794 P
5-TR30	ET639437	TR 2SC945L Q, P
5-TR31	ET328868	TR 2SD1012-V G, H
5-TR32,33	ET639437	TR 2SC945L Q, P
5-TR34	ET539133	TR 2SA733A P
5-TR35	ET310920	△ TR 2SC1846 R, S
5-TR36to39	ET639437	TR 2SC945L Q, P
5-TR40	ET666404	△ TR 2SD571 K,L
5-TR41	ET328868	TR 2SD1012-V G, H
5-TR42	ET639437	TR 2SC945L Q,P
5-D2	ED316143	D SILICON H 1S2473HS F10
5-D3 to 7	ED560913	D SILICON V 1S2473VE
5-D8	ED305704	D ZENER H HZ4 B2
5-D9	ED316143	D SILICON H 1S2473HS F10
5-D10to14	ED560913	D SILICON V 1S2473VE
5-D15	ED306109	D SILICON W03B 100/1.0A
5-D16	ED560913	D SILICON V 1S2473VE
5-D17	ED306014	D ZENER H HZ9 C3
5-D18,19	ED322982	D GERMA V 1S188FM-1-LR F07
5-D20	ED560913	D SILICON V 1S2473VE
5-D21	ED331626	D ZENER H HZ3 B2
5-D22	ED560913	D SILICON V 1S2473VE
5-VC1,2	EC315346	C S-FIX H ECV-1ZW50x32E 5.0-55
5-J1	EJ308986	PIN J 1784P1782 P 4P (U, J, C, A)
5-J1	EJ337381	JACK PLATE UD-0096 (E,B,S,V)
5-J2	EJ337622	PHONE J THROW HLJ0345-210 3P 2x3P
5-J2	EJ321328	PHONE J HLJ0345-010 2x3P (P)
5-J3	EJ337623	PHONE J 3P HLJ0315-023 6,3
5-J3	EJ330545	PHONE J 3P HLJ0315-020 6,3 (P)
5-SW1	ES328415	SW SOLENOID SWE018401 18V 04-2S
5-SW2	ES311975	SW SOLENOID R8150050 27V 10-2W
5-SW3	ES283072	SW SLIDE SSC22LP 2-02-02N (E, B, S, V)
5-VR1	EV315542	R S-FIX H D8 3P 103
5-VR2,3	EV315541	R S-FIX H D8 3P 503
5-VR4	EV315753	R S-FIX H D8 3P 203
5-VR5	EV316442	R S-FIX H D8 3P 102
5-VR6	EV315540	R S-FIX H D8 3P 502
5-VR7	EV313538	VR ROTARY 16P20x1B B103
5-RL1	EP328529	RELAY LEAD LAB2NS 2NO 12V
5-VL1	EO321336	COIL VARI 1 FE002 10mH
5-L1	EO669273	COIL FIX 2 FLSR200 18μH
5-T1	EO331625	COIL OSC 1 0365-034 100KHz
5-FL3,4	EO315758	COIL TUN 1 100S-431 100KHz
5-R 34	ER488024	△ R OMF H FS 1W 330J
5-R35	ER330977	△ R OMF H FS 2W 680J
5-C1	EC314990	C STY V SNP CQFS 101J 50DC
5-C3	EC314995	C STY V SNP CQFS 331J 50DC
5-C6	EC314995	C STY V SNP CQFS 331J 50 DC
5-C35	EC331631	C STY V SNP CQFS 821J 50DC
5-C48	EC313265	C STY V 152J 500DC

REF. NO.	PARTS NO.	DESCRIPTION
5-C60	EC321340	C PP V APS 8201G 100DC
5-C63	EC314990	C STY V SNP CQFS 101J 50DC
5-5	ZW263946	RV NYL40x050

6. SYS. CON. P.C BOARD BLOCK

REF. NO.	PARTS NO.	DESCRIPTION
6-1	BAT2040A050A	PC SYSCON (2) BLK GX-F66RC
6-IC1	EI336801	IC MB8841-564M
6-IC2	EI331658	IC MB8841-461M
6-IC3,4	EI331659	IC M54528P
6-IC5	EI319555	IC μPD4049C
6-IC6	EI331660	IC SN7417N
6-IC7	EI331661	IC SN7405N
6-TR1	ET324134	TR 2SA984K E,F
6-TR2	ET554657	TR 2SA733A P,Q
6-TR3to6	ET324134	TR 2SA984K E,F
6-TR7to9	ET554657	TR 2SA733A P,Q
6-TR10to12	ET635231	TR 2SC536NP F,G
6-TR13to36	ET554657	TR 2SA733A P,Q
6-D1 to 5	ED560913	D SILICON V 1S2473VE
6-D6	ED308952	D GERMA V 1K34A-LR F07
6-D7 to 10	ED560913	D SILICON V 1S2473VE
6-D11 to 14	ED308952	D GERMA V 1K34A-LR F07
6-C6	EC363688	C MC V FM 101K 500DC
6-C7	EC285513	C MC V FM 220K 500DC
6-J1	EJ324276	DIN J TCS4680-01-111 P 8P

7. POWER SUPPLY P.C BOARD BLOCK

REF. NO.	PARTS NO.	DESCRIPTION
7-1	BAT2023A070A	PC POWER BLK GX-F66R(U)
7-2	BAT2023A070B	PC POWER BLK GX-F66R(U)
7-3	BAT2023A070C	PC POWER BLK GX-F66R(C)
7-4	BAT2023A070D	PC POWER BLK GX-F66R(A)
7-5	BAT2023A070E	PC POWER BLK GX-F66R(E)
7-6	BAT2023A070F	PC POWER BLK GX-F66R(B)
7-7	BAT2023A070G	PC POWER BLK GX-F66R(V)
7-8	BAT2023A070H	PC POWER BLK GX-F66R(S)
7-TR1	ET307349	△ TR 2SD794 P,Q
7-TR2	ET639437	△ TR 2SC945L Q,P
7-TR3	ET375603	△ TR 2SC1061 B,C
7-TR4	ET639437	△ TR 2SC945L Q,P
7-TR5	ET375603	△ TR 2SC1061 B,C
7-TR6	ET639437	△ TR 2SC945L Q,P
7-TR7	ET307349	△ TR 2SD794 P,Q
7-TR8	ET639437	△ TR 2SC945L Q,P
7-D1	ED319463	△ D SILICON 4B4B41 100/4.0A
7-D2	ED324013	D ZENER H HZ20 2
7-D3	ED319463	△ D SILICON 4B4B41 100/4.0A
7-D4	ED319167	D ZENER H HZ6 C3
7-D5	ED306109	△ D SILICON W03B 100/1.0A
7-D6	ED331667	D ZENER H HZ7 A1
7-J1	EJ310567	△ SOCKET INLET 0378P-CGS E 2P (B, S, V)
7-SW1	ES312234	△ SW PUSH SDL-1P 01-1 F (U, E, B, S, V)
7-SW1	ES312235	△ SW PUSH SDL-1P 01-1 J(F)
7-SW1	ES312238	△ SW PUSH SDL-1P 01-1 K(C,A)
7-VS1	MZ283140	△ SOCKET SELECTOR X17238 6P (U)
7-C1	EC320548	△ C CE V F 103Z 250AC (U, J, A)
7-C1	EC314688	△ C CE V FZ 103P 125AC(C)
7-C1	EC330307	△ C MMY V ECQUF 472M2 50AC (E, S, B, V)
7-C2	EC324023	C EC V CUT USM 222M 350DC

8. DRIVE P.C BOARD BLOCK

REF. NO.	PARTS NO.	DESCRIPTION
8-1	BAT2023A300A	PC DRIVE BLK GX-F66R
8-IC1	EI302681	IC SN7404N
8-IC2	EI201940	IC NJM4558S
8-TR1	ET307349	△ TR 2SD794 P,Q
8-TR2	ET324134	△ TR 2SA984K E, F
8-TR3,4	ET200985	TR 2SC2603 F,G
8-TR5	ET309353	TR 2SC2274 E,F
8-TR6	ET307349	△ TR 2SD794 P,Q
8-TR7	ET324134	△ TR 2SA984K E, F
8-TR8,9	ET200985	TR 2SC2603 F,G
8-TR10	ET309353	TR 2SC2274 E,F
8-TR11	ET324134	△ TR 2SA984K E, F
8-TR12,13	ET200985	TR 2SC2603 F,G
8-TR14	ET309353	TR 2SC2274 E,F
8-TR15	ET328868	TR 2SD1012-V G,H
8-TR16,17	ET328438	TR 2SB808-V F, G
8-TR18	ET328868	TR 2SD1012-V G,H
8-TR19to26	ET200985	△ TR 2SC2603 F,G
8-TR28to33	ET200985	TR 2SC2603 F,G
8-TR36	ET328868	TR 2SD1012-V G,H
8-TR37	ET200985	TR 2SC2603 F,G
8-D1	ED328486	D ZENER H HZ15 3
8-D2	ED560913	D SILICON V 1S2473VE
8-D3,4	ED306109	D SILICON W03B 100/1.0A
8-D5	ED560913	D SILICON V 1S2473VE
8-D6,7	ED306109	D SILICON W03B 100/1.0A
8-D8	ED560913	D SILICON V 1S2473VE
8-D9 to 11	ED306109	D SILICON W03B 100/1.0A
8-D12 to 17	ED560913	D SILICON V 1S2473VE
8-D18	ED306109	D SILICON W03B 100/1.0A
8-D19	ED316143	D SILICON H 1S2473HS F10
8-D20	ED560913	D SILICON V 1S2473VE
8-VR1	EV522652	R S-FIX V V8K1-1 3P 105
8-C14	EC314992	C STY V F05 CQF09 681J 50DC
8-C19	EC307793	C EC V F05 NP SM 220M 10DC

9. DOLBY (C) P.C BOARD BLOCK

REF. NO.	PARTS NO.	DESCRIPTION
9-1	BAT2040A070A	PC DOLBY(C) BLK GX-F66RC
9-IC1	EI336737	IC HA11226
9-IC2	EI336761	IC LA6458S
9-TR1 to 12	ET639437	TR 2SC945L Q,P
9-TR13	ET336735	TR 2SA733(A) P,K
9-D1	ED331227	D GERMA V 1K34A-UF SNP
9-D2	ED624903	D SILICON H 1S2473
9-D3	ED331227	D GERMA V 1K34A-UF SNP
9-D4,5	ED624903	D SILICON H 1S2473
9-D6	ED331227	D GERMA V 1K34A-UF SNP
9-SW1	ES332448	SW LEVER 01030123 2-10-03N
9-SW2	ES336779	SW LEVER 2-02-02S
9-SW3	ES328530	SW SOLENOID SWE018404 18V 04-2N
9-VR1	EV202110	VR ROTARY 16P11x0S A503 A503
9-VR2	EV315540	R S-FIX H D8 3P 502
9-VR3	EV322411	R S-FIX H D8 3P 202
9-VR4,5	EV315542	R S-FIX H D8 3P 103
9-FL1,2	EO336738	COIL TUN 1 102AK-004 19.8 KHz
9-FL3	ER328491	FILTER DB D07-003K 100KHz
9-FL4	ER328490	FILTER DB D07-001K 19KHz
9-C7	EC306980	C STY V F05 500 221J 50DC
9-C13	EC314990	C STY V SNP CQFS 101J 50DC

10. KEYBOARD (2) P.C BOARD BLOCK

REF. NO.	PARTS NO.	DESCRIPTION
KEYBOARD (2) P.C BOARD BLOCK		
10-1	BAT2040A060A	PC KEYBOARD (2) BLK GX-F66RC
10-IN1	EM331669	IND LE SL-1003 CHARACTER
10-D1 to 3	ED308953	D GERMA H 1K34A-LH SNP
10-D4 to 7	ED560913	D SILICON V 1S2473VE
10-SW1,2	ES324677	SW TACT KEC11904
10SW3to14	ES323367	SW TACT KEC10001
10SW15 to18	ES324677	SW TACT KEC11904
10SW20to24	ES323367	SW TACT KEC10001
MEMORY P.C BOARD BLOCK		
10-SW1	ES201527	SW SLIDE SSS212 1-01-02N

11. LD P.C BOARD BLOCK

REF. NO.	PARTS NO.	DESCRIPTION
11-TR1,2	ET200985	TR 2SC2603 F,G
11-TR3	ET200558	TR 2SA1115 E,F

12. FILTER P.C BOARD BLOCK

REF. NO.	PARTS NO.	DESCRIPTION
12-L1,2	EO669273	COIL FIX 2 FL5R200 18μH

ASSEMBLY BLOCK

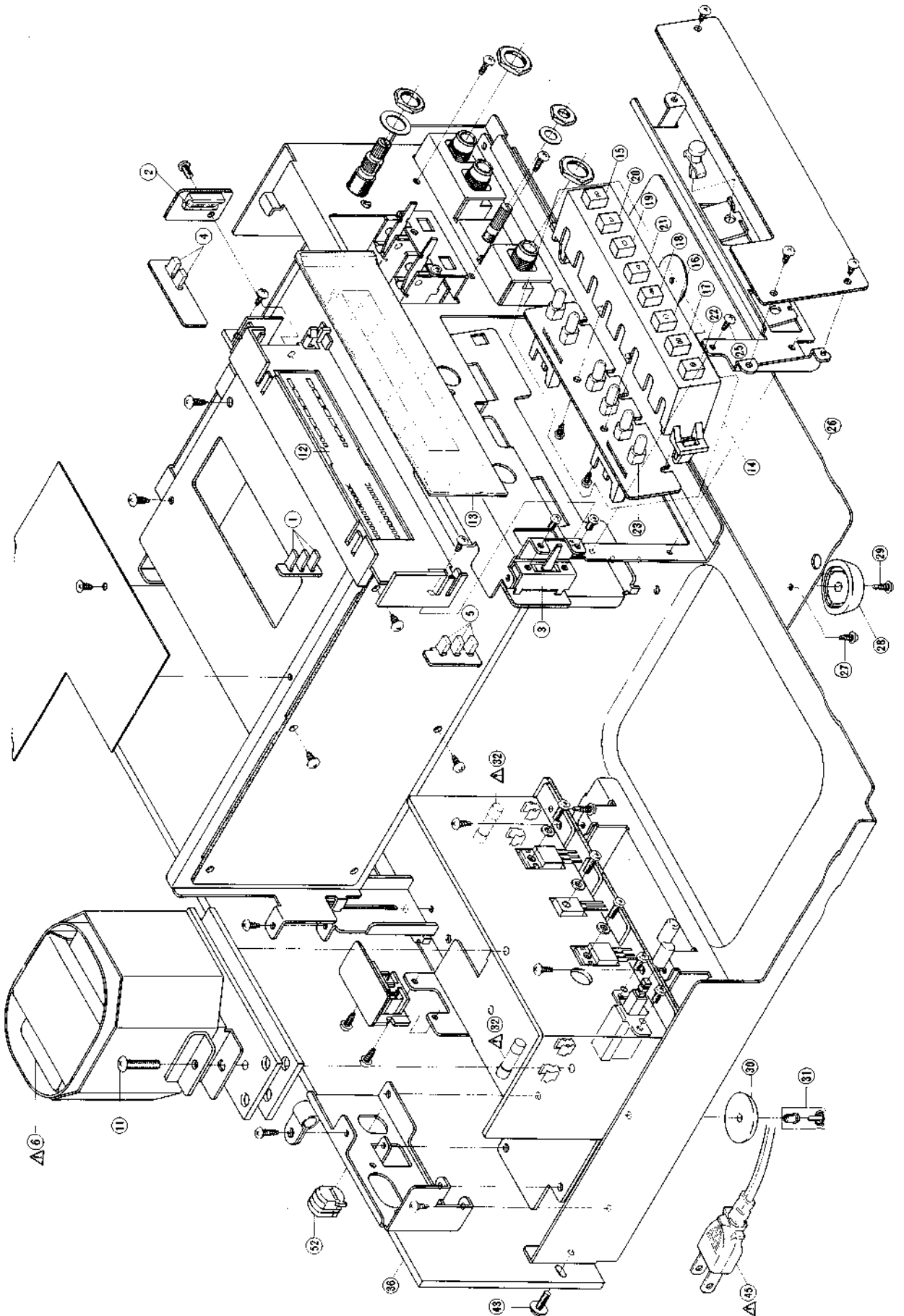

13. ASSEMBLY BLOCK

REF. NO.	PARTS NO.	DESCRIPTION	REF. NO.	PARTS NO.	DESCRIPTION
TAPE LED P.C BOARD BLOCK			13-51x	EW315767	△ AC CORD 2 CORES KP-419C/KS-15 E (V)
13-1	ED322773	D LED SLP-255D-01 GRN (D1,2,3)	13-52	SZ631945	STRAIN RELIEF SR-4N-4 (U, J, C, A, E)
LAMP METER P.C BOARD BLOCK					
13-2	EL304025	PL H LEAD 10V 110mA (IN1)			
SLIDE P.C BOARD BLOCK					
13-3	ES337322	SW SLIDE 00230699 2-02-03N (SW1)			
DOLBY LED P.C BOARD BLOCK					
13-4	ED322773	D LED SLP-255D-01 GRN (D1,2)			
REVERSE P.C BOARD BLOCK					
13-5	ED322773	D LED SLP-255D-01 GRN (D1,2,3)			
POWER SUPPLY BLOCK					
13-6	BT331662	△ TRANS POWER T2023-U			
13-7x	BT331663	△ TRANS POWER T2023-J			
13-8x	BT331665	△ TRANS POWER T2023-C,A (C,A,V)			
13-9x	BT331664	△ TRANS POWER T2023-E			
13-10x	BT331666	△ TRANS POWER T2023-B,S			
13-11	ZS201033	ST PAN40x16STL CMT			
HOLDER METER BLOCK					
13-12	ED331263	IND LE LT-1016 GRAPH (IN901)			
ASSEMBLY BLOCK					
13-13	SZ331956	MASK METER			
13-14	ES331670	SW OPERATION F66R 8P L			
13-15	SK780000	KNOB OPERATION (FF)			
13-16	SK780001	KNOB OPERATION (REC)			
13-17	SK780002	KNOB OPERATION (PAUSE)			
13-18	SK780004	KNOB OPERATION (REW)			
13-19	SK780005	KNOB OPERATION (STOP)			
13-20	SK780006	KNOB OPERATION (PLAY)			
13-21	SK780007	KNOB OPERATION (REVERSE)			
13-22	SK780008	KNOB OPERATION (REC MUTE)			
13-23	EL300186	PL LEAD 8V 60mA			
13-24x	TC780009	RUBBER SHEET SW ASSIST J-P5348-03			
13-25	ZS463353	T2BR30x08STL BNI			
13-26	SP331961	COVER BOTTOM PLATE			
13-27	ZS325495	T2BR30x06STL CMT			
13-28	SA202118	FOOT			
13-29	ZS490228	T2BID30x08STL CMT			
13-30	SA313811	RUBBER FOOT			
13-31	ZW231030	RV NYL30x045 BL			
13-32	EF306950	△ FUSE TSC A 250V 2A (F1,2) (U,J)			
13-33x	EF306954	△ FUSE TSC 125V 2A (F1,2) (C,A)			
13-34x	EF601301	△ FUSE SEMKO T 250V 2A (F1,2) (E,B,S,V)			
13-35x	EF593706	△ FUSE SEMKO T 250V 0.50A (F3) (B)			
13-36	SP332004R	PANEL REAR BOARD GX-F66RC(U)AS			
13-37x	SP332004V	PANEL REAR BOARD GX-F66RC(J)AS			
13-38x	SP332004T	PANEL REAR BOARD GX-F66RC(C)AS			
13-39x	SP332004U	PANEL REAR BOARD GX-F66RC(A)AS			
13-40x	SP332004S	PANEL REAR BOARD GX-F66RC(E)AS			
13-41x	SP332004Q	PANEL REAR BOARD GX-F66RC(B,S) AS			
13-42x	SP332004W	PANEL REAR BOARD GX-F66RC(V) AS			
13-43	ZS332007	T2PAN30x10 STL CMT C080			
13-44x	ZW305013	RV POP32 (A)			
13-45	EW306428	△ AC CORD 2 CORES KP-205A,VFF J (U)			
13-46x	EW306427	△ AC CORD 2 CORES KP-211, VFF J (J)			
13-47x	EW305691	△ AC CORD 2 CORES KP-8, SPT-1 UC (C,A)			
13-48x	EW201796	△ AC CORD 2 CORES KP-419C, LTCE-2F E (E)			
13-49x	EW322400	△ AC CORD 2 CORES GTBS-2F/KS-15 B (B)			
13-50x	EW322401	△ AC CORD 2 CORES KP-560/S-15 S (S)			

FINAL ASSEMBLY BLOCK

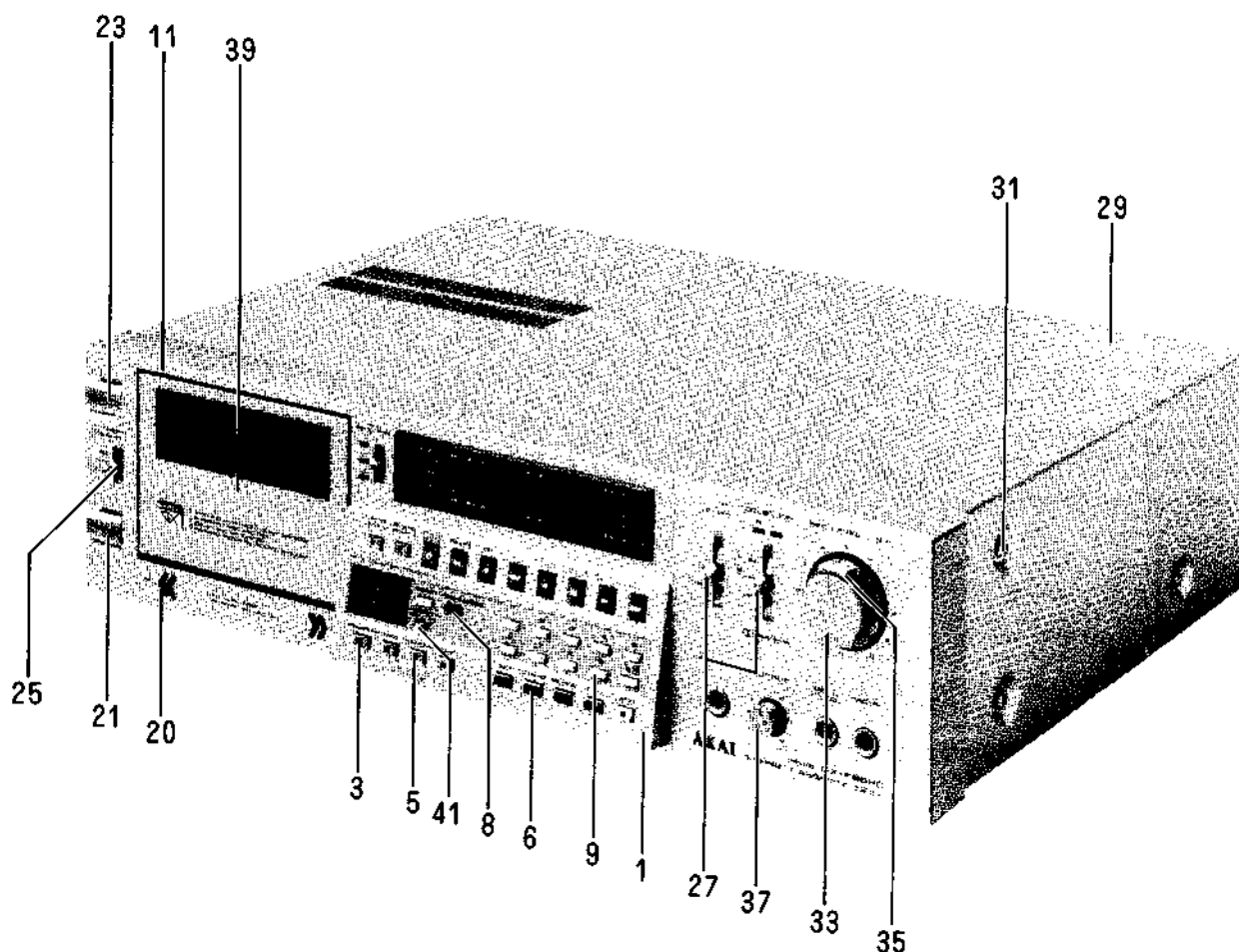

14. FINAL ASSEMBLY BLOCK

REF. NO.	PARTS NO.	DESCRIPTION
SUB PANEL BLOCK		
14-1	BDT2040A030A	PANEL SUB BLK GX-F66RC
14-2x	BDT2040A030B	PANEL SUB BLK GX-F66RC-P
14-3	SK331981A	KNOB PUSH (A)
14-4x	SK331981C	KNOB PUSH (A)-P
14-5	SK331982	KNOB INDICATOR
14-6	SK331983A	KNOB PUSH (B)
14-7x	SK331983D	KNOB PUSH (B)-P
14-8	SK331984A	KNOB PUSH (C)-RED
14-9	SK331984C	KNOB PUSH (C)-GRAY
14-10x	SK331984D	KNOB PUSH (C)-P
FRONT PANEL BLOCK		
14-11	BDB331974L	PANEL FRONT GX-F66RC(MONO) PART (U, J, C, A)
14-12x	BDB331974J	PANEL FRONT GX-F66RC PART (E, B, S, V)
14-13x	BDB331974M	PANEL FRONT GX-F66RC (MONO)-P PART (U, J, C, A)
14-14x	BDB331974K	PANEL FRONT GX-F66RC-P PART (E, B, S, V)
14-15x	TC331975A	LID ESCUTCHEON
14-16x	TC331975C	LID ESCUTCHEON-P
14-17x	SE331976A	ESCUTCHEON SIDE
14-18x	SE331976C	ESCUTCHEON SIDE-P
14-19x	ZS332008	PT PAN30x06STL CMT
14-20	SZ325789	DIRECTION LENS
14-21	SK317468A	KNOB PUSH (A)
14-22x	SK317468E	KNOB PUSH (A)-P

REF. NO.	PARTS NO.	DESCRIPTION
14-23	SK317468C	KNOB PUSH (B)
14-24x	SK317468F	KNOB PUSH (B)-P
FINAL ASSEMBLY BLOCK		
14-25	SK328391	SLIDE KNOB
14-26x	SK336304	SLIDE KNOB-P
14-27	SK329033	LEVER KNOB (A)
14-28x	SK336307	LEVER KNOB-P
14-29	SP332003D	COVER UPPER (C)
14-30x	SP332003E	COVER UPPER (C)-P
14-31	ZS341963	XST BID40x06STL NI3
14-32x	ZS341964	XST BID40x06 STL BN1
14-33	SKB318794	KNOB DOUBLE (UPPER) PART GX-F90
14-34x	SKB604320	KNOB DOUBLE (UPPER) P PART
14-35	SK331998A	KNOB DOUBLE (LOWER)
14-36x	SK331998C	KNOB DOUBLE (LOWER)-P
14-37	SK317537	KNOB (B)
14-38x	SK336305	KNOB (B)-P
14-39	BDB332000E	LID PANEL (C) PART
14-40x	BDB332000F	LID PANEL (C)-P PART
14-41	SK331985A	KNOB MEMORY
14-42x	SK331985C	KNOB MEMORY-P
14-43x	BC330054	CASE WOOD (GX-F66RC-W)
14-44x	SA202118	FOOT (GX-F66RC-W)
14-45x	ZW326042	PW35x070x050STL CMT (GX-F66RC-W)
14-46x	ZS414268	T1TRS35x10STL CMT (GX-F66RC-W)
14-47x	ZW381881	PW41x130x100STL CMT (GX-F66RC-W)
14-48x	ZS330057	ST BID40x22STL CMT (GX-F66RC-W)

SECTION 3

SCHEMATIC DIAGRAM

1. SCHEMATIC DIAGRAM OF ICs
2. GX-F66RC No. 2-1 1640216A POWER & SYSCON SCHEMATIC DIAGRAM
3. GX-F66RC No. 2-2 1640217A AMP SCHEMATIC DIAGRAM

HA12028

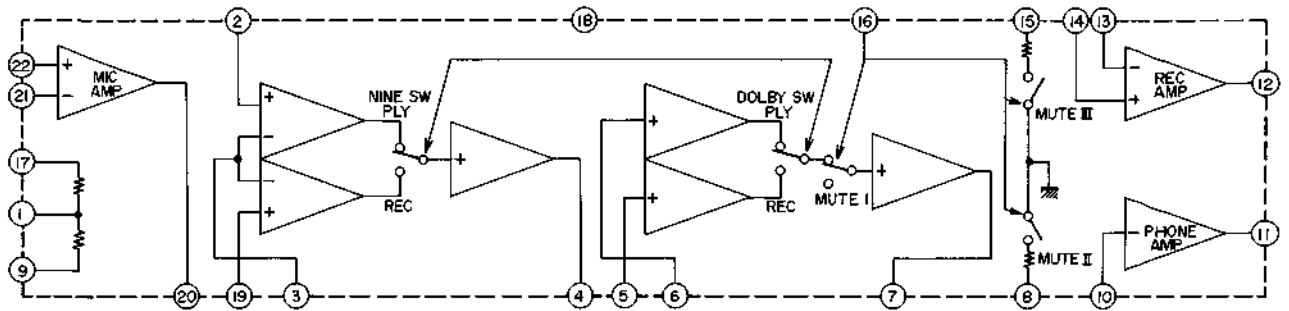

M54528P

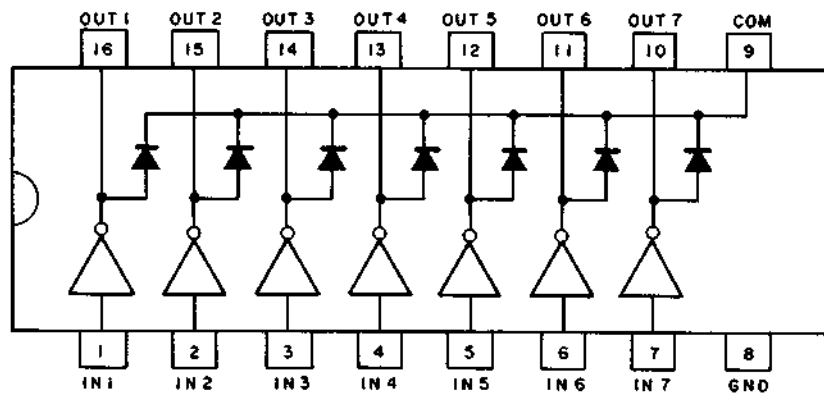

MB8841-564M/461M

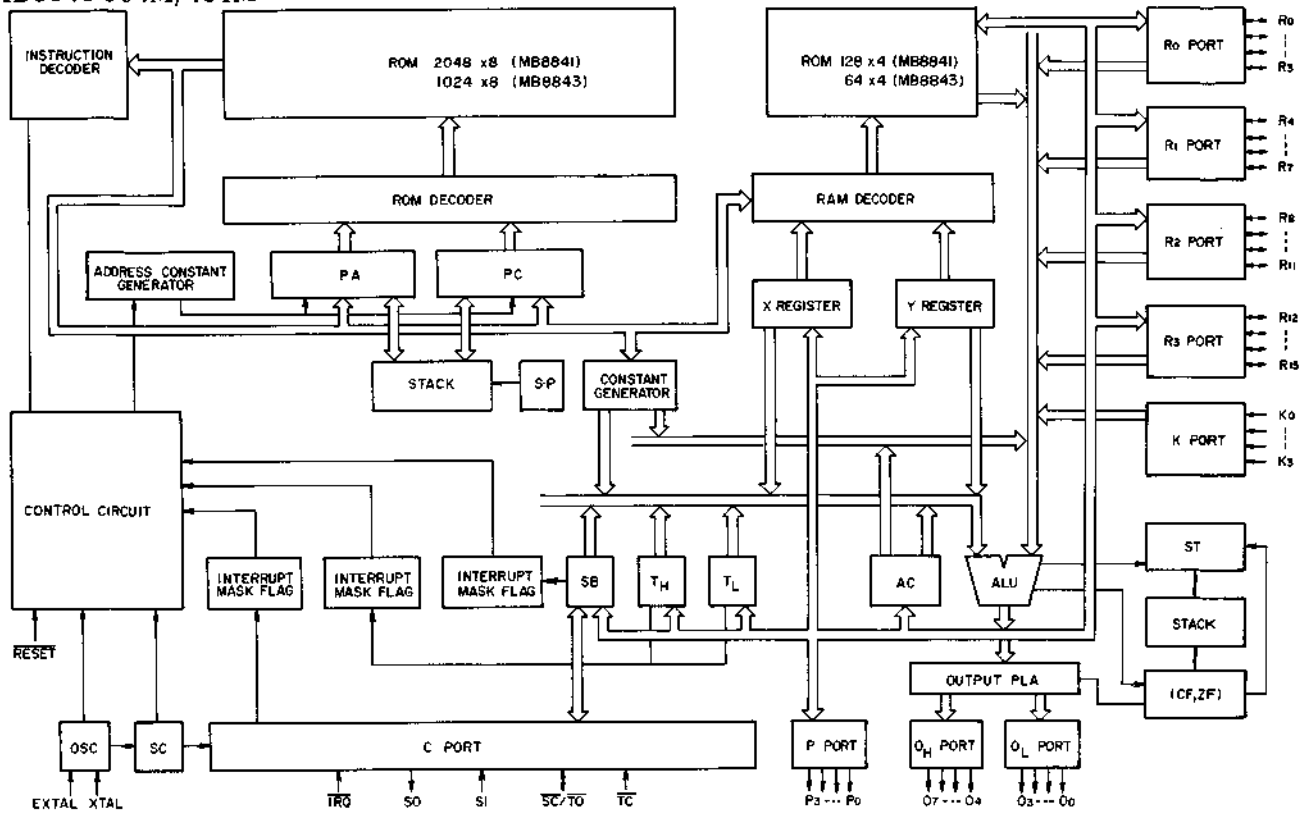

NJM4558S/LA6458S

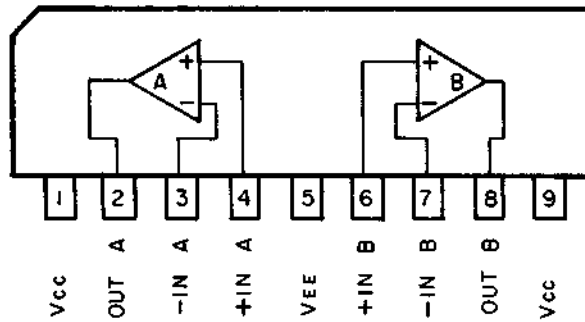

SN7405

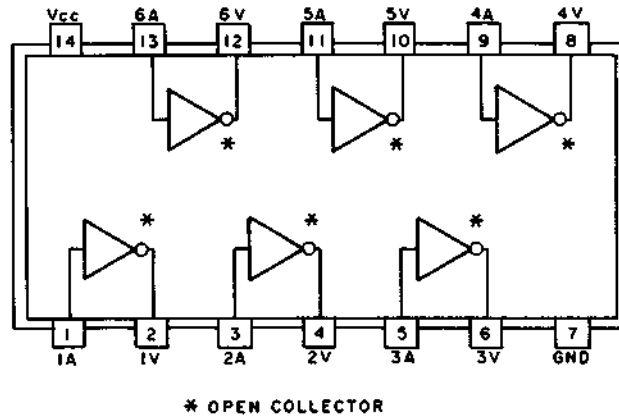

SN7417N

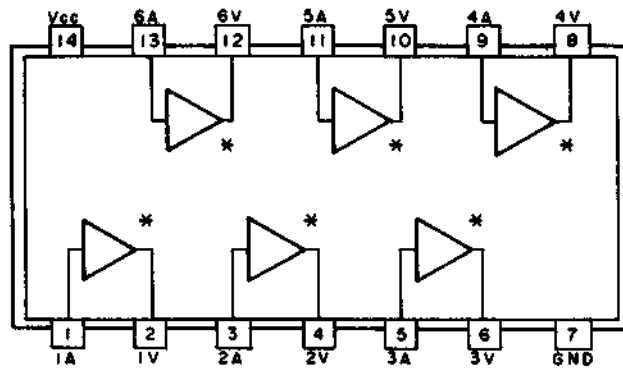

* OPEN COLLECTOR

μPD4049C

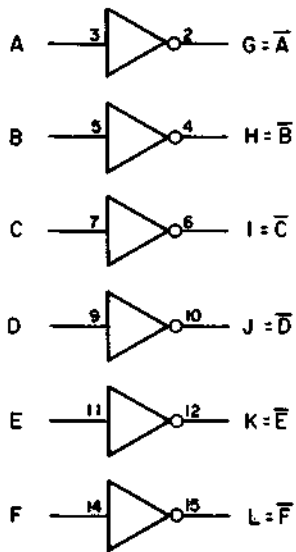

Vcc 1

Vss 8

NC = 13

NC = 16

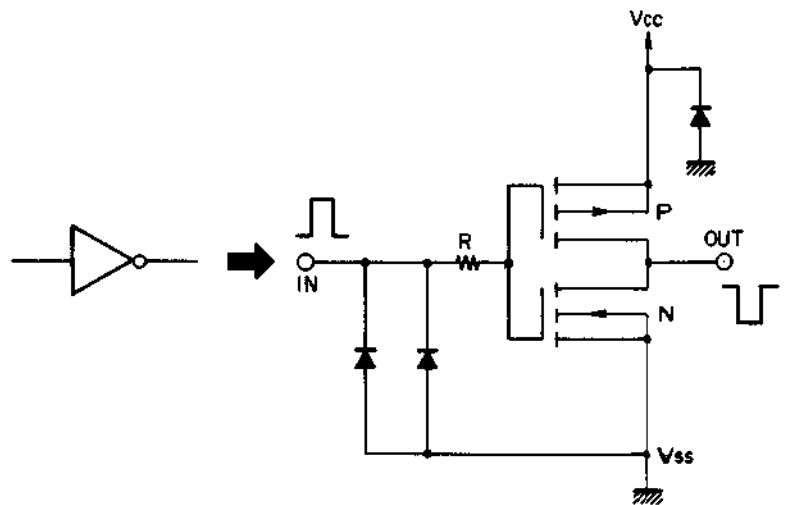

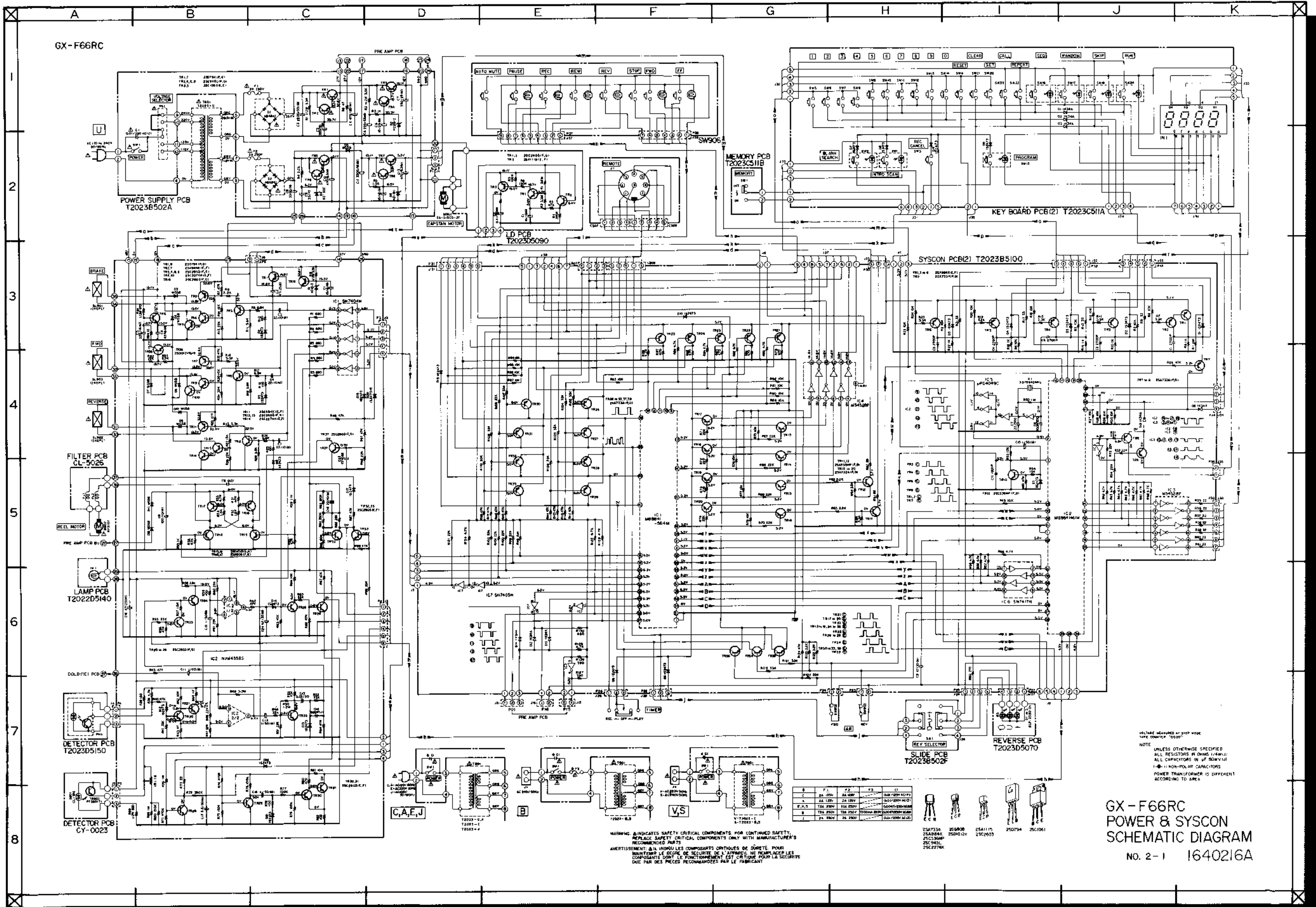

VOLTAGE MEASURED AT STOP MODE
UNLESS OTHERWISE SPECIFIED
ALL RESISTORS IN OHMS UNLESS
ALL CAPACITORS IN UF 50V UNLESS
NOTED
- = NON-POLAR CAPACITORS
POWER TRANSFORMER IS DIFFERENT
ACCORDING TO AREA

**GX-F66RC
POWER & SYSCON
SCHEMATIC DIAGRAM**
No. 2-1 1640216A

WARNING: INDICATES SAFETY CRITICAL COMPONENTS FOR CONTINUED SAFETY.
REPLACE SAFETY CRITICAL COMPONENTS ONLY WITH MANUFACTURER'S
RECOMMENDED PARTS.
AVERTISSEMENT: IL INDIQUE LES COMPOSANTS CRITIQUES DE SÉCURITÉ POUR
MAINTENIR LE DEGRÉ DE SÉCURITÉ DE L'APPAREIL. NE REMPLACEZ LES
COMPOSANTS SANS LE FONCTIONNEMENT EST CRITIQUE POUR LA SÉCURITÉ
QUE PAR DES PIÈCES RECOMMANDÉES PAR LE FABRICANT.

Q	1	2	3	4
B	2A 120V	2A 120V	2A 120V	2A 120V
C	2A 120V	2A 120V	2A 120V	2A 120V
D	2A 120V	2A 120V	2A 120V	2A 120V
E	2A 120V	2A 120V	2A 120V	2A 120V
F	2A 120V	2A 120V	2A 120V	2A 120V
G	2A 120V	2A 120V	2A 120V	2A 120V
H	2A 120V	2A 120V	2A 120V	2A 120V
I	2A 120V	2A 120V	2A 120V	2A 120V
J	2A 120V	2A 120V	2A 120V	2A 120V
K	2A 120V	2A 120V	2A 120V	2A 120V

