

# SERVICE MANUAL

## PARTS LIST

**MODEL GX-650D**

**AKAI**

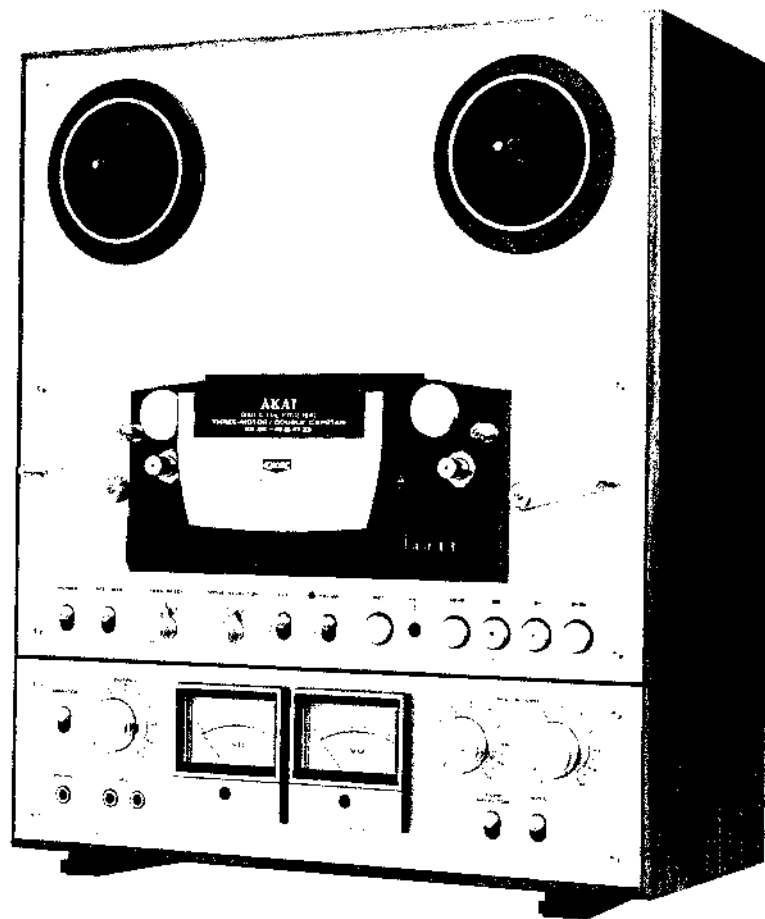

## STEREO TAPE DECK

MODEL **GX-650D**

SECTION 1	SERVICE MANUAL .....	1
SECTION 2	PARTS LIST .....	27
SECTION 3	SCHEMATIC DIAGRAM .....	48

---

SECTION 1

# SERVICE MANUAL

## TABLE OF CONTENTS

I.	TECHNICAL DATA .....	2
II.	DISMANTLING OF UNIT .....	3
III.	ARRANGEMENT OF PRINCIPAL PARTS .....	4
IV.	MECHANISM ADJUSTMENT .....	5
	1. CAPSTAN SHAFT LOOSE PLAY ADJUSTMENT .....	5
	2. BRAKE SOLENOID POSITION ADJUSTMENT .....	5
	3. BRAKE TENSION ADJUSTMENT .....	6
	4. PINCH ROLLER SOLENOID POSITION ADJUSTMENT .....	7
	5. SHIFTER SOLENOID POSITION ADJUSTMENT .....	7
	6. PINCH ROLLER PRESSURE ADJUSTMENT .....	8
	7. REEL TABLE HEIGHT ADJUSTMENT .....	8
	8. TAPE GUIDE HEIGHT ADJUSTMENT .....	9
	9. TENSION LEVER HEIGHT ADJUSTMENT .....	9
	10. CONFIRMATION OF POINT AT WHICH LEFT AND RIGHT TENSION ARMS OPERATE .....	10
	11. TENSION ARM RETURN TENSION ADJUSTMENT .....	11
	12. HALL IC(DN835) AND ROTARY MAGNET CLEARANCE ADJUSTMENT .....	11
V.	HEAD ADJUSTMENT .....	12
VI.	AMPLIFIER SYSTEM ADJUSTMENT .....	14
	1. DC POWER SUPPLY VOLTAGE ADJUSTMENT .....	14
	2. TAPE SPEED ADJUSTMENT .....	14
VII.	DC RESISTANCE OF VARIOUS COILS .....	16
VIII.	CLASSIFICATION OF VARIOUS P.C. BOARDS .....	17
	1. RELATION OF P.C BOARD TITLE AND NUMBER .....	17
	2. COMPOSITION OF VARIOUS P.C BOARDS .....	17

For basic adjustments, measuring methods, and operating principles, refer to GENERAL OPERATING PRINCIPLES AND ADJUSTMENTS.

# I. TECHNICAL DATA

TRACK SYSTEM	4 track, 2 channel stereo/monaural system
REEL CAPACITY	Up to 10-1/2" reel
TAPE SPEED	15, 7-1/2 ips ( $\pm 0.5\%$ )
WOW/FLUTTER	Less than 0.04% RMS at 15 ips Less than 0.055% RMS at 7-1/2 ips Less than 0.07% RMS at 3-3/4 ips
FREQUENCY RESPONSE	30 to 30,000 Hz $\pm 3$ dB at 15 ips using Akai LN-150 tape 30 to 26,000 Hz $\pm 3$ dB at 7-1/2 ips using Akai LN-150 tape 30 to 20,000 Hz $\pm 3$ dB at 3-3/4 ips using Akai LN-150 tape
DISTORTION	Less than 0.4% at 15 and 7-1/2 ips (1,000 Hz "0" VU) Less than 0.9% at 3-3/4 ips (1,000 Hz "0" VU)
SIGNAL TO NOISE RATIO	Better than 58 dB (measured via tape with peak recording level of +6 VU)
ERASE RATIO	Better than 70 dB
BIAS FREQUENCY	150 kHz
HEADS	(3): One GX Playback Head, one GX Recording Head and one Erase Head
MOTORS	(3): One AC Servo Motor for capstan drive, and two Eddy Current Motors for reel drive
FAST FORWARD AND REWIND TIME	120 sec using a 2,400 ft tape
OUTPUT JACKS	Line (2): 0.775V (0VU) Required load impedance: More than 20 k ohms Phone (1): 30 mV/8 ohms
INPUT JACKS	Microphone (2): 0.3 mV/ Required microphone impedance: 600 ohms Line (2): 80 mV/100 k ohms
TRANSISTOR	2SA564(Q) (R) ... 3                      2SA640 (E) ... 4 2SC458LG (C) (D) (P) ... 14          2SC711(D) (E) (F) ... 12 2SC711(D2) ... 1                        2SC711 SPECIAL (E2) ... 2 2SC792 ... 1                              2SC945(P) (Q) (R) ... 14 2SC945L (P) (Q) ... 15                2SC971 ... 1 2SC1014 (C) (D) ... 1                  2SC1247A (B) (V) ... 3 2SD234 ... 1
DIODE	1N34A ... 2                                1S2473 ... 20 1S2473VE ... 14                        10D1 ... 7 10D4 ... 6                                10DC2 (BLK) ... 1 10DC2 (RED) ... 1                      RD7A (L) (N) ... 3
POWER REQUIREMENTS	CSA, UL and LA Models: 120V 60 Hz only CEE Models: 220V 50 Hz only Other Models: 100 to 240V 50/60 Hz (Switchable)
DIMENSIONS	524(H) x 442(W) x 258(D) mm (20.6" x 17.4" x 10")
WEIGHT	26.2 kg (57.6 lbs)

NOTES: 1. For improvement purposes, specifications and design are subject to change without notice.

2. Noise reduction circuit made under license from Dolby Laboratories Inc.

The word 'DOLBY' and the Double-D symbol are trademarks of Dolby Laboratories Inc.

## II. DISMANTLING OF UNIT

In case of trouble, etc. necessitating disassembly, please disassemble in the order shown in photographs. Reassemble in reverse order.

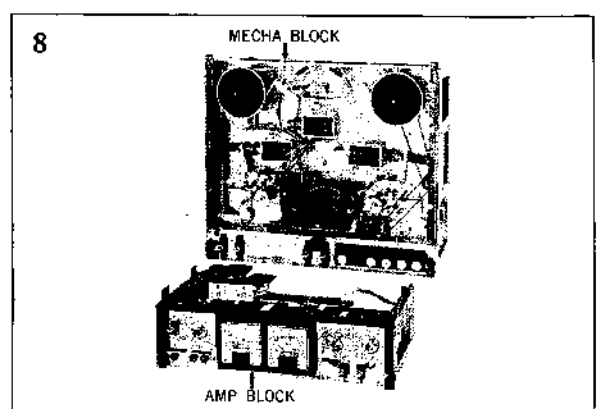
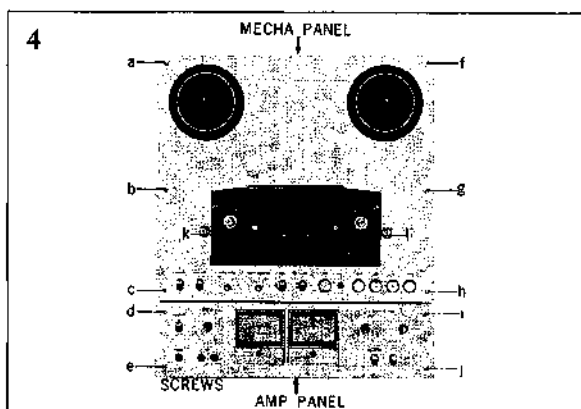
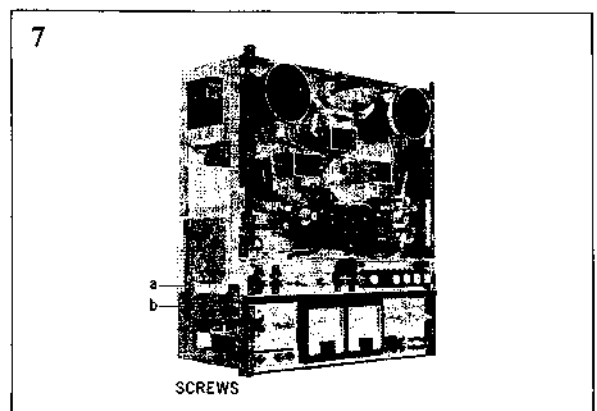
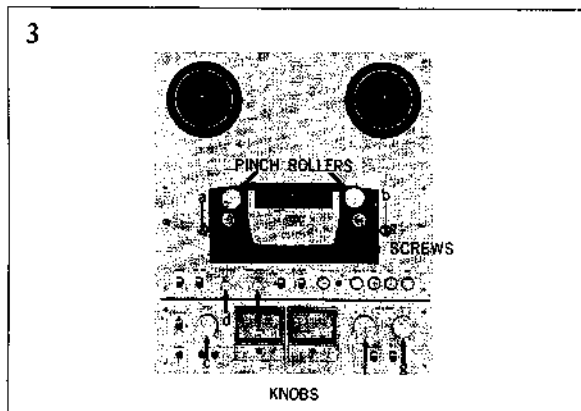
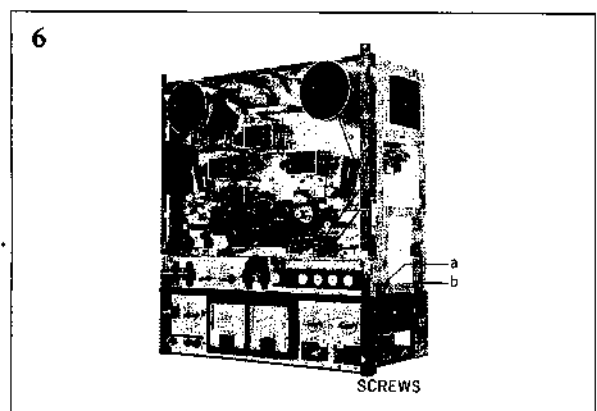
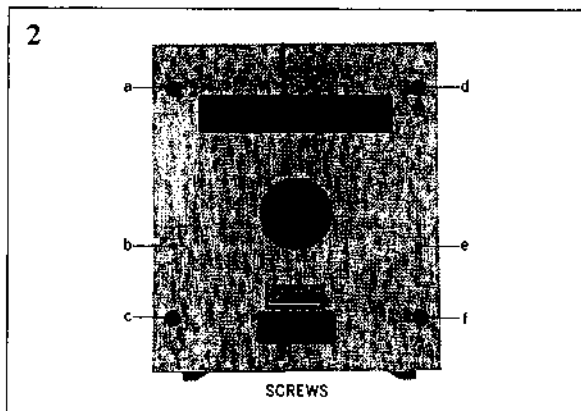
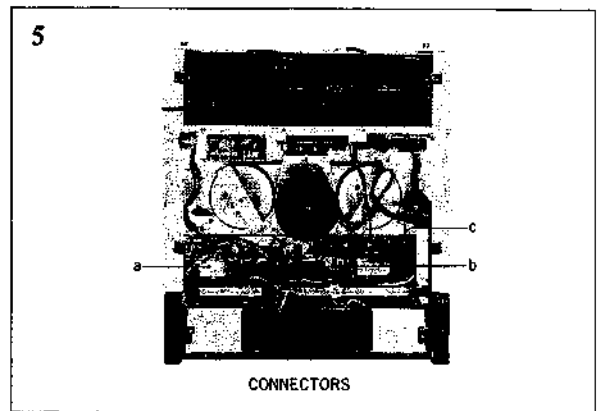
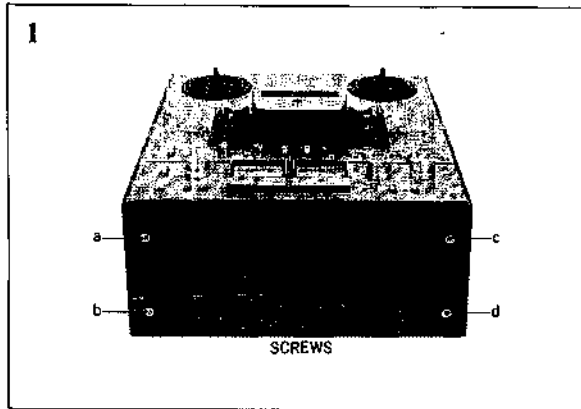

### III. ARRANGEMENT OF PRINCIPAL PARTS

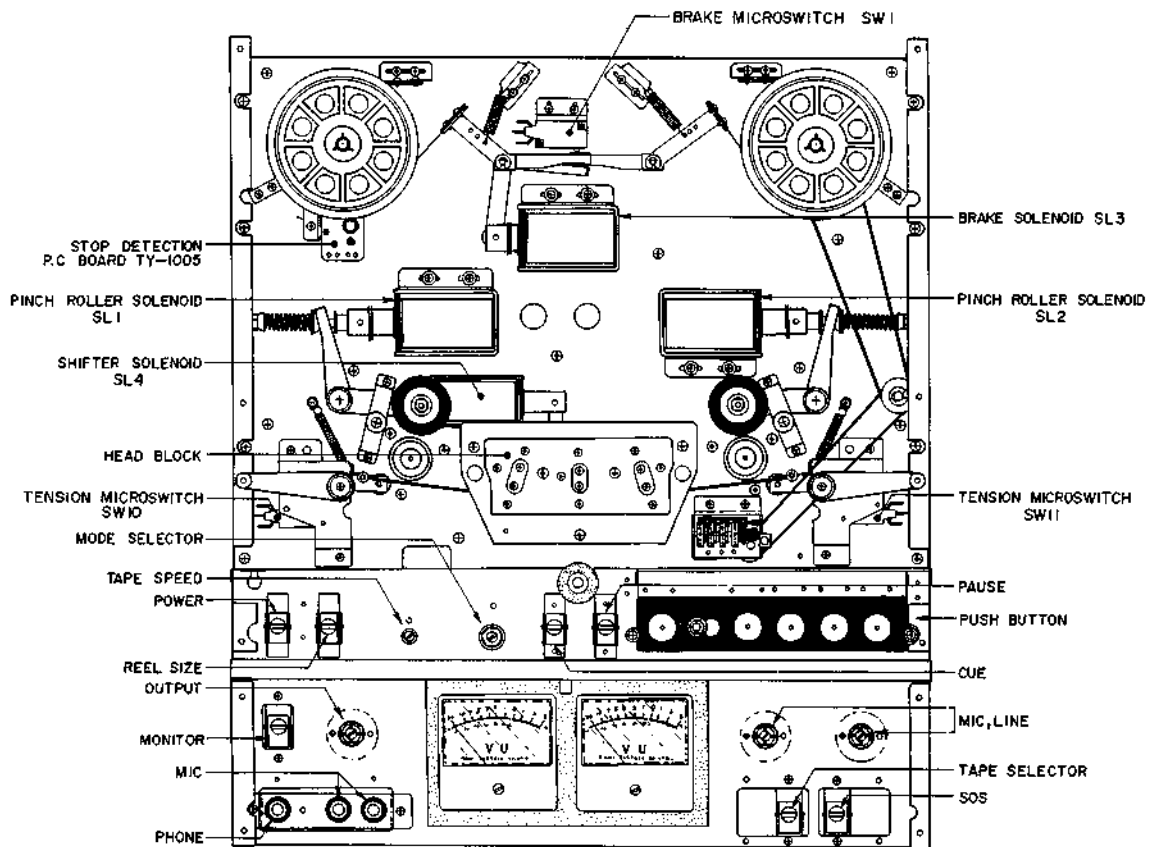

Fig. 1 Front View

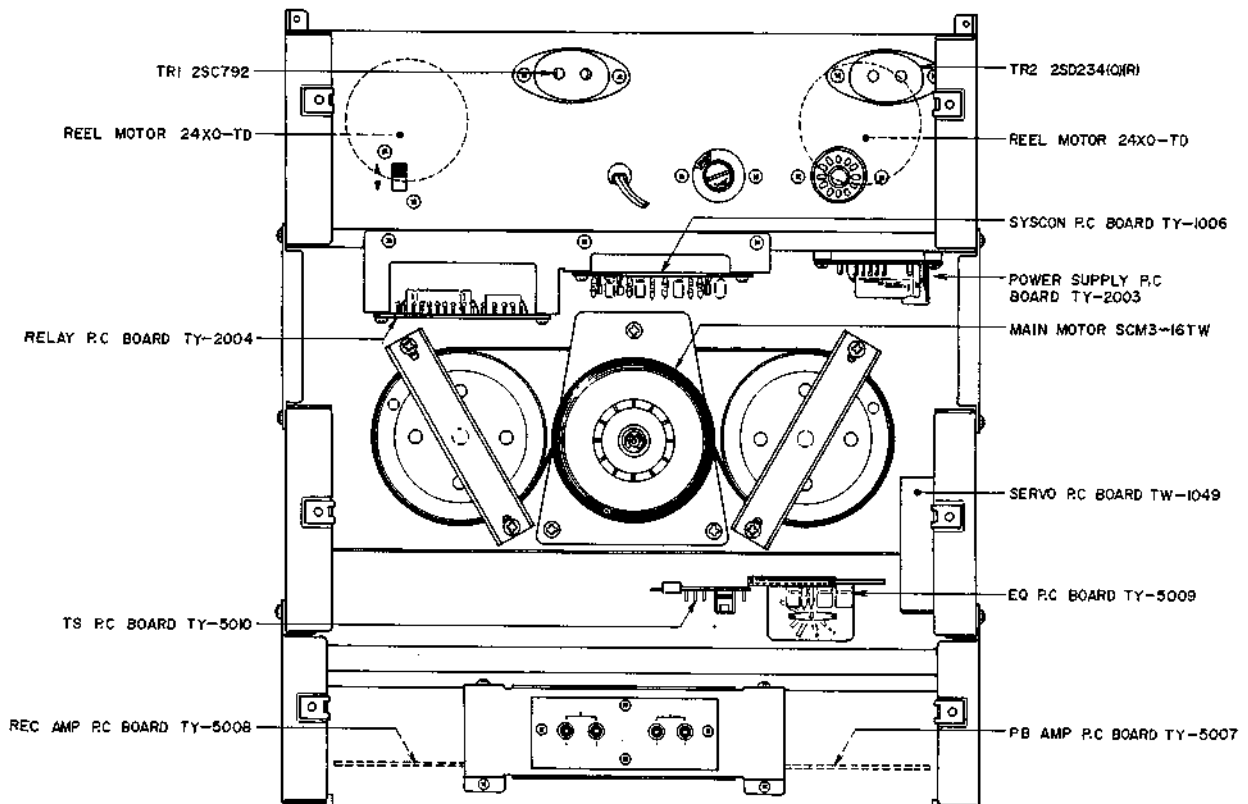

Fig. 2 Rear View

## IV. MECHANISM ADJUSTMENT

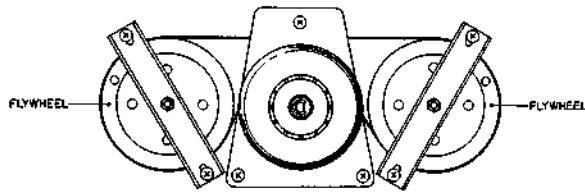

Fig. 3

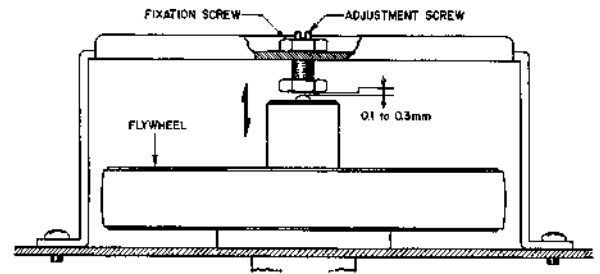

Fig. 4

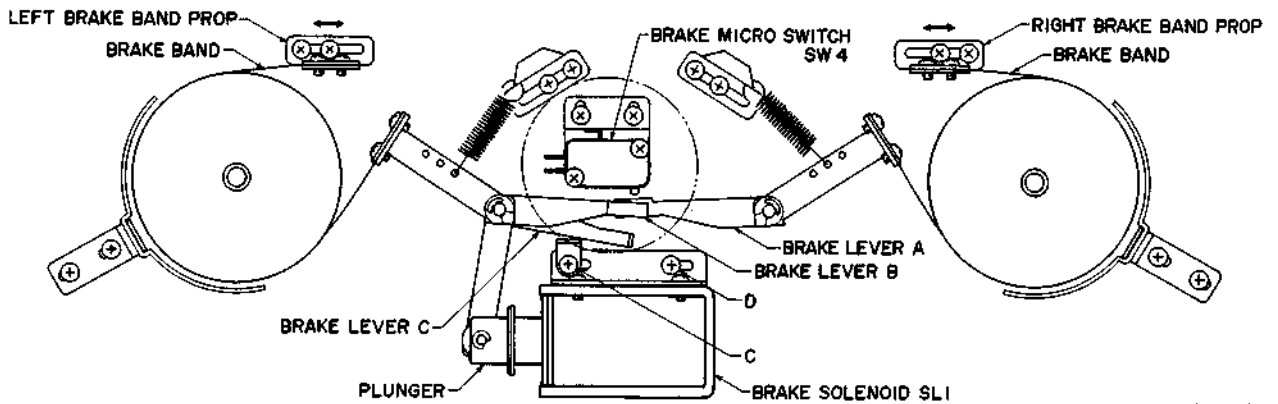

Fig. 5

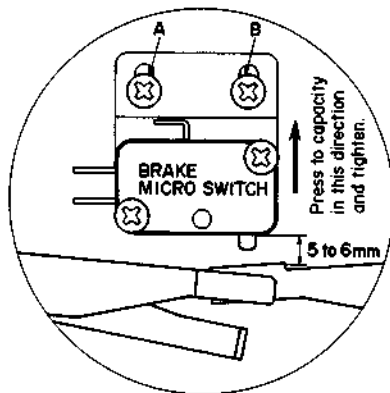

Fig. 6

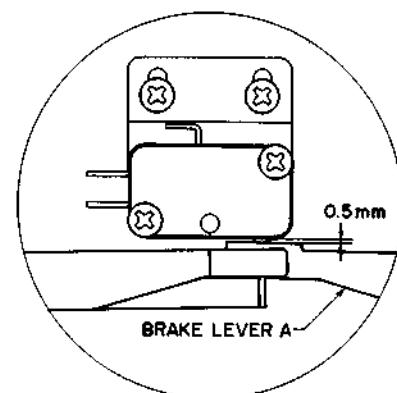

Fig. 7

### 1. CAPSTAN SHAFT LOOSE PLAY ADJUSTMENT (Refer to Figs. 3 and 4)

Adjust by turning Adjustment Screw to obtain a 0.1 to 0.3 mm degree of loose play when the capstan shaft is moved as indicated by the arrow mark. Tighten fixation nut to maintain optimum adjusted condition.

NOTE: When replacing a flywheel, replace with same rank flywheel as previously installed.

### 2. BRAKE SOLENOID POSITION ADJUSTMENT

- 1) As shown in Fig. 6, press brake micro switch as far as it will go toward the top of the mechanical frame, and tighten screws A and B.
- 2) Move the Right Brake Band Prop shown in Fig. 5 so that the gap between Brake Lever A and the body of Brake Micro Switch is 5 to 6mm (See Fig. 6).
- 3) Move the Left Brake Band Prop shown in Fig. 5 so that Brake Lever B and Brake Lever A are simultaneously operated by Brake Lever C.
- 4) As shown in Fig. 7, when the plunger is pulled, tighten Brake Solenoid Screws C and D at position at which the gap between Brake Lever A and the body of Brake Micro Switch is 0.5 mm at the narrowest place.

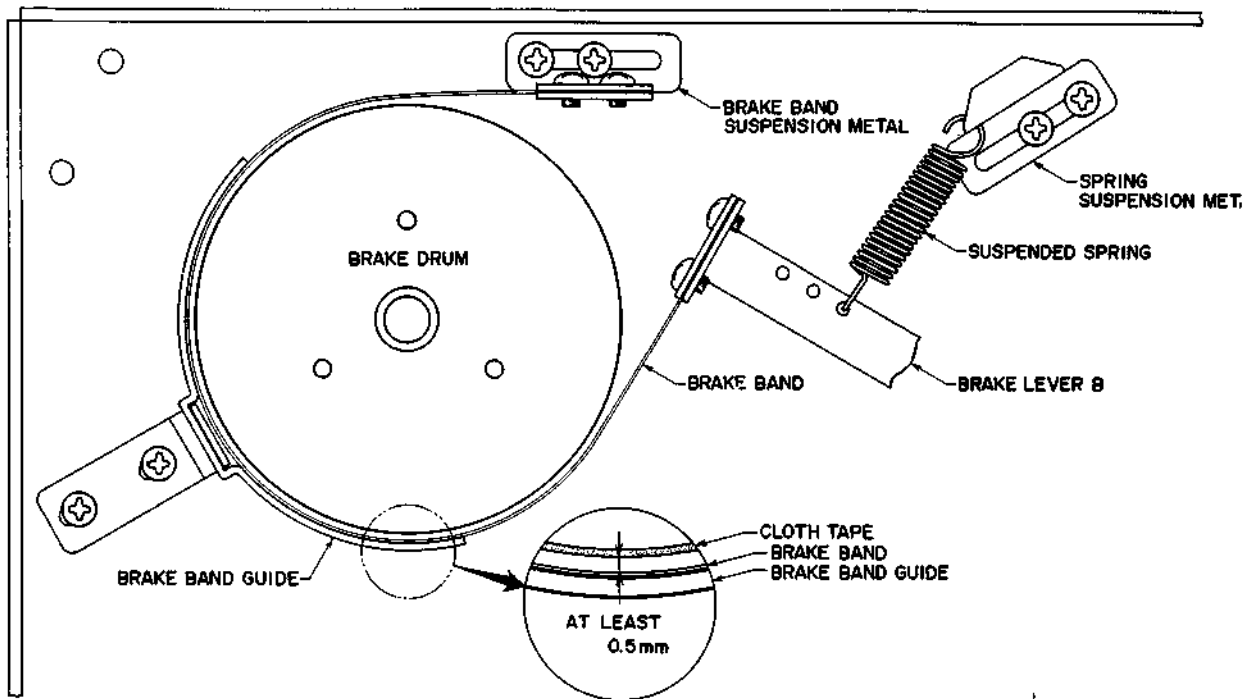

Fig. 8

### 3. BRAKE TENSION ADJUSTMENT

1) As shown in Fig. 9, brake tension is measured with a spring gauge using a 60 mm diameter tape wound on a 5" reel. Ideal brake tension is  $650 \pm 50$  gr. and left/right deviation allowance should be within 50 gr.

2) Methods for brake tension adjustment are as follows: (See Fig. 8)

Method A: Change position of suspended spring.

Method B: Adjust position of spring suspension metal.

**NOTE:** Following Brake Tension Adjustment, confirm that when the machine is set to each of the various modes (except stop mode), the brake band separates from the cloth tape on the brake drum by at least 0.5 mm. (See Fig. 8)

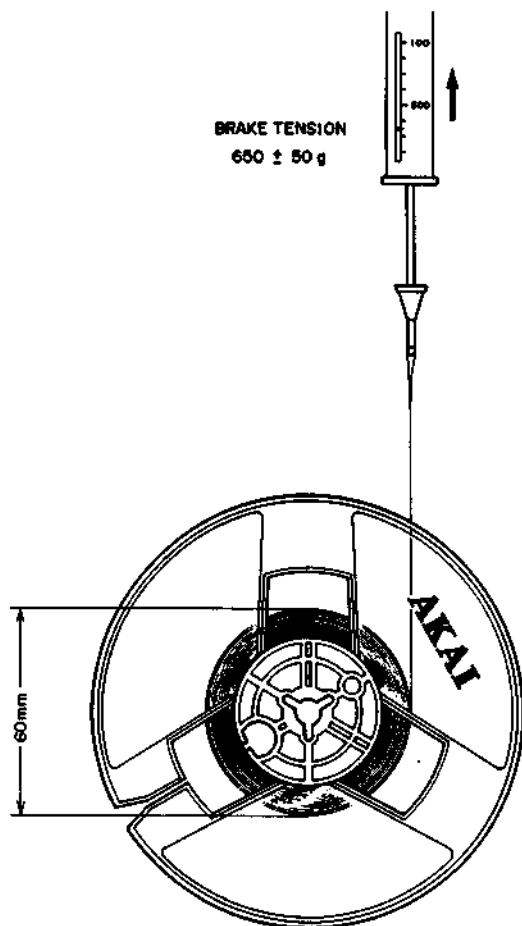

Fig. 9



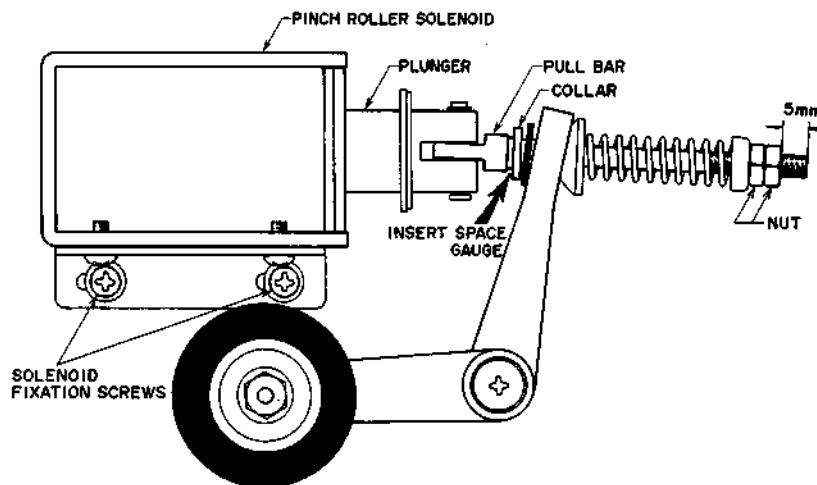
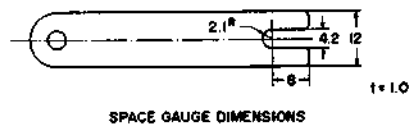

Fig. 10



SPACE GAUGE DIMENSIONS

Fig. 11

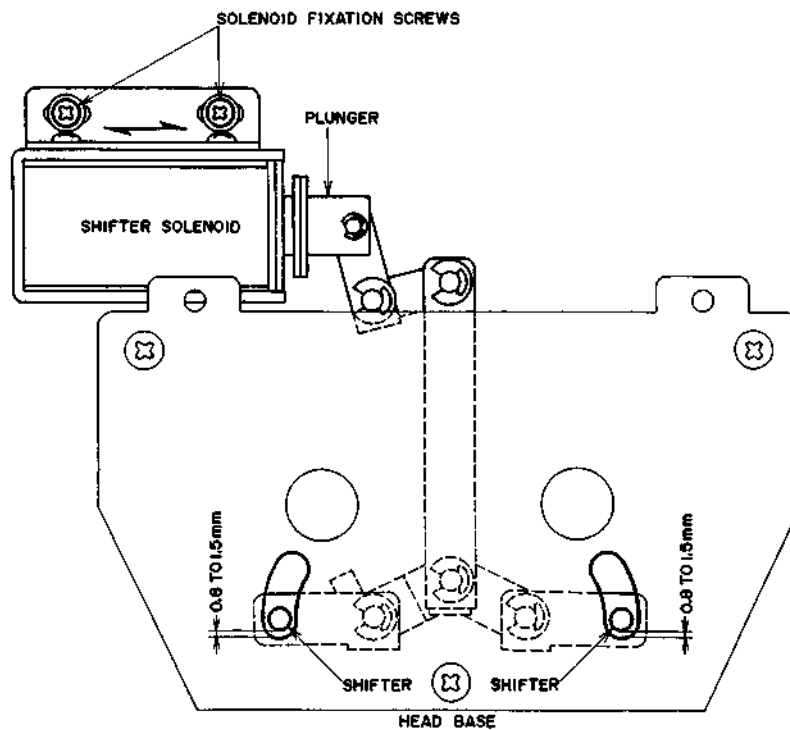

Fig. 12

#### 4. PINCH ROLLER SOLENOID POSITION ADJUSTMENT

Set nut so that the screw part of the pull bar extends 5 mm further than the nut, and insert a space gauge of which the dimensions are the same as shown in Fig. 11 between the collar and pull bar shown in Fig. 10, and fix at position at which the pinch roller rests against the capstan. Set left and right to same degree.

#### 5. SHIFTER SOLENOID POSITION ADJUSTMENT

As shown in Fig. 12, adjust the position of the Shifter Solenoid so that when the plunger is pulled, the gap of the shifter and oblong hole of the head base is 0.8 to 1.5 mm.

NOTE: The tape must definitely not touch the head.

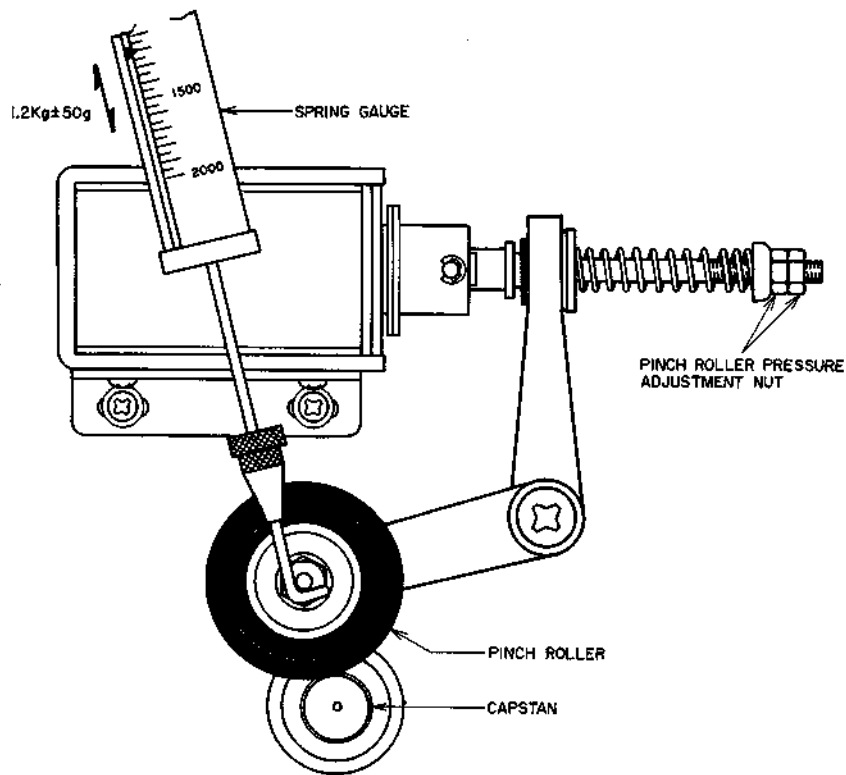

Fig. 13

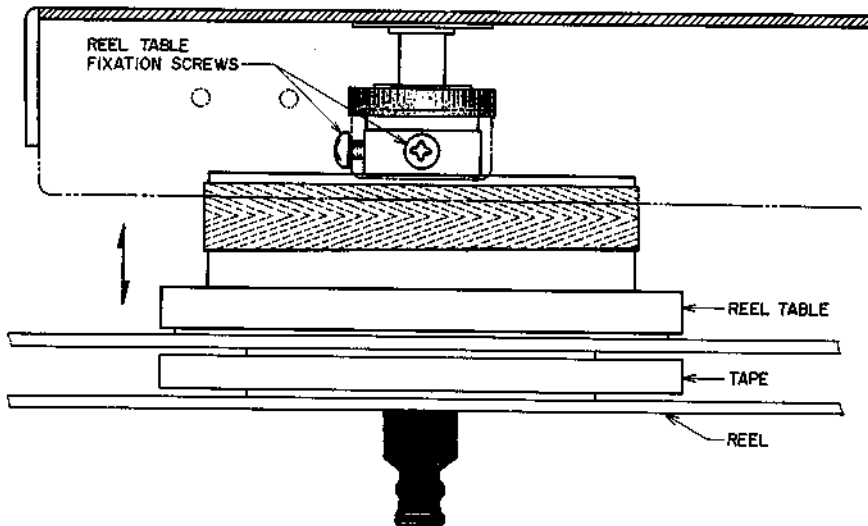

Fig. 14

## 7. REEL TABLE HEIGHT ADJUSTMENT (See Fig. 14)

Load a tape (left and right reel tables), but do not thread tape through left/right tape guides and tension levers. Set to F.Fwd and Rwd mode and adjust the position of reel tables in direction of arrow mark so that the tape winds in the center of the reels. Tighten reel table fixation screws at most ideal position.

NOTE: Tape should wind in center of reel regardless of type of reel used.

## 6. PINCH ROLLER PRESSURE ADJUSTMENT

As shown in Fig. 13, pull back the Pinch Roller with a spring gauge, and then return. Take a reading of the spring gauge indication at the time the pinch roller touches the capstan. Adjust Pinch Roller Pressure Adjustment nut to obtain a 1.2 kg  $\pm$ 50 gr spring scale indication at this time.

NOTE: Because this model employs a dual capstan system, adjust so that the difference in pinch roller pressure between left and right is within 50 gr.

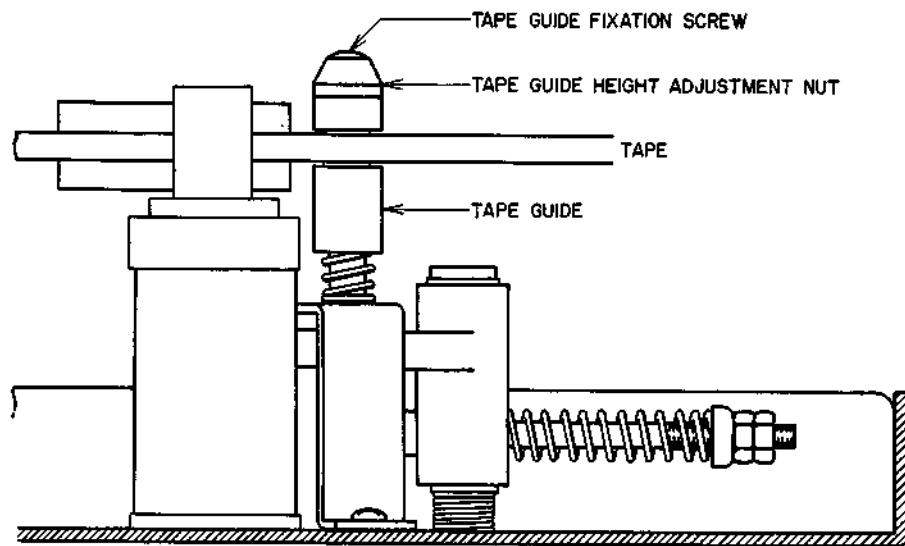

Fig. 15

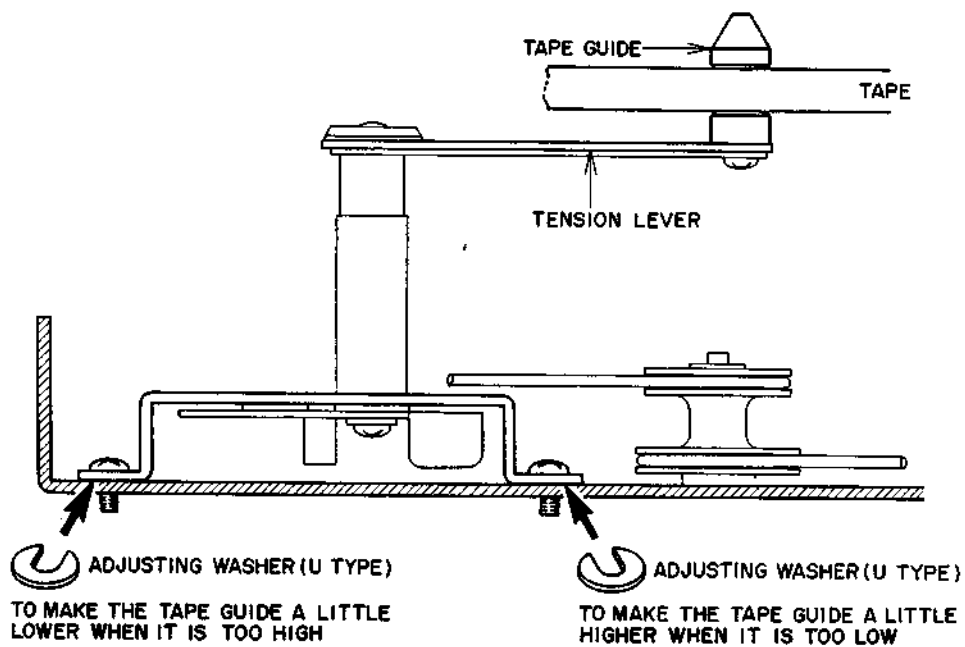

Fig. 16

## 8. TAPE GUIDE HEIGHT ADJUSTMENT

(See Fig. 15)

Thread tape over left and right tape guides, but do not thread over left and right tension levers. Loosen tape guide fixation screws and adjust left and right tape guide height adjustment nuts so that at Fwd mode, the tape runs on the center of the tape guides. Tighten tape guide fixation screws to maintain this condition.

## 9. TENSION LEVER HEIGHT ADJUSTMENT

Thread tape over left and right tension levers and over the left and right tape guides properly. Adjust tension lever height by inserting an Adjusting washer (U type) as shown in Fig. 16 so that at Fwd mode, the tape travels on the center of the tape guide.

**NOTE:** The right hand side tape guide is shown in Fig. 16, but when making the left hand side tension lever height adjustment, the screw on the left is used to make the tape guide higher, and the screw on the right is used to make the tape guide lower.

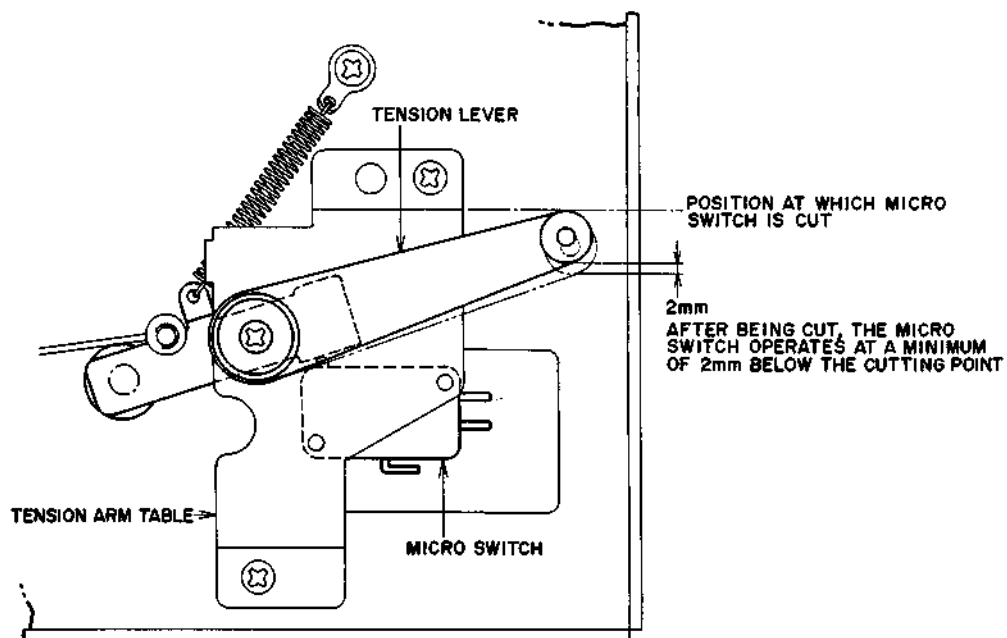

Fig. 17

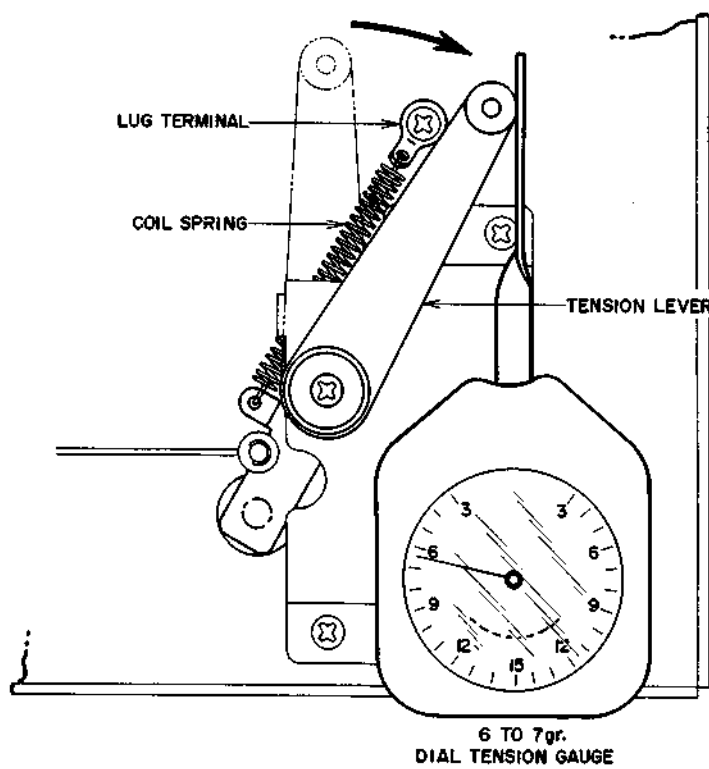

Fig. 18

**10. CONFIRMATION OF POINT AT WHICH LEFT AND RIGHT TENSION ARMS OPERATE**

Confirm that the left and right micro switches operate at the positions indicated in Fig. 17.

**11. TENSION ARM RETURN TENSION ADJUSTMENT**

Bend the oval shaped lug terminal and adjust the strength of coil spring so that as shown in Fig. 18, when the tension arm returns in the direction of the arrow, the tension registered with a tension gauge is 6 to 7 gr.

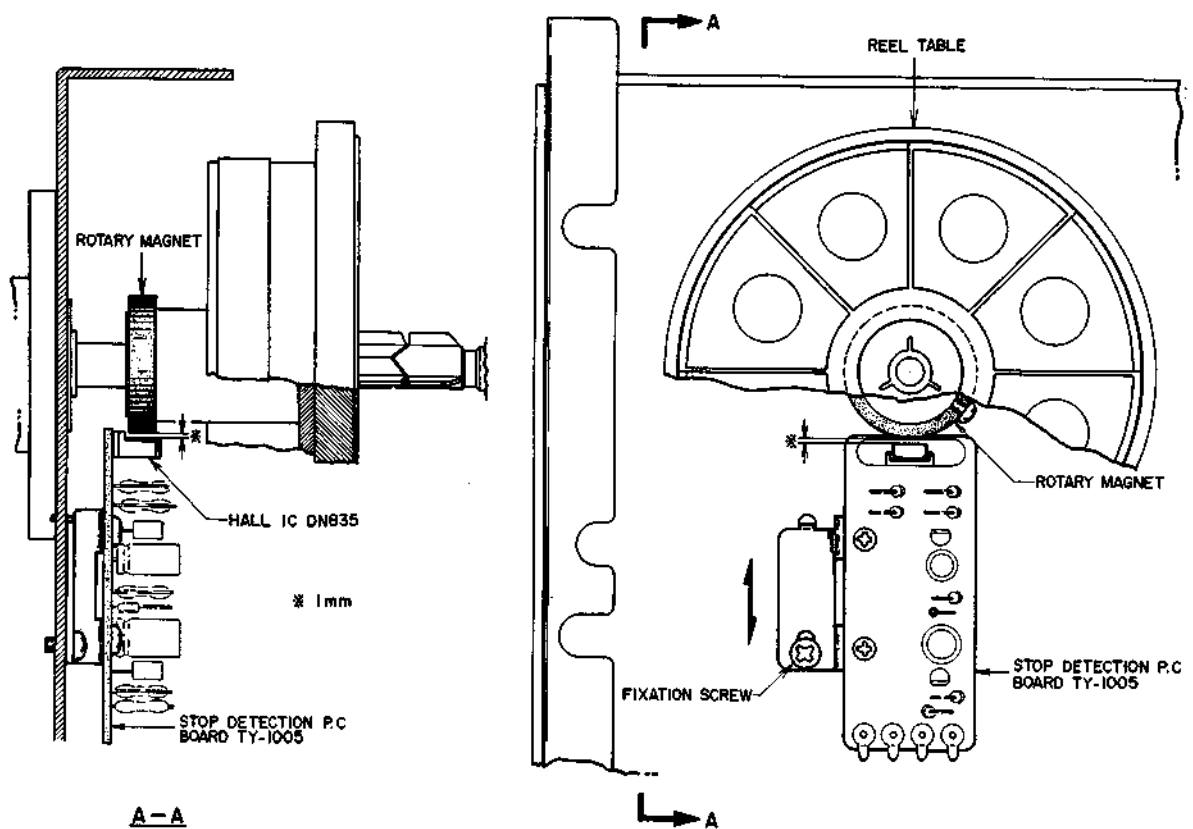

Fig. 19

## 12. HALL IC (DN835) AND ROTARY MAGNET CLEARANCE ADJUSTMENT

Adjust the Stop Detection P.C Board in the directions indicated by the arrow mark so that the gap between the Hall IC and the rotary magnet is 1 mm as shown in the Fig. 19.

# V. HEAD ADJUSTMENT

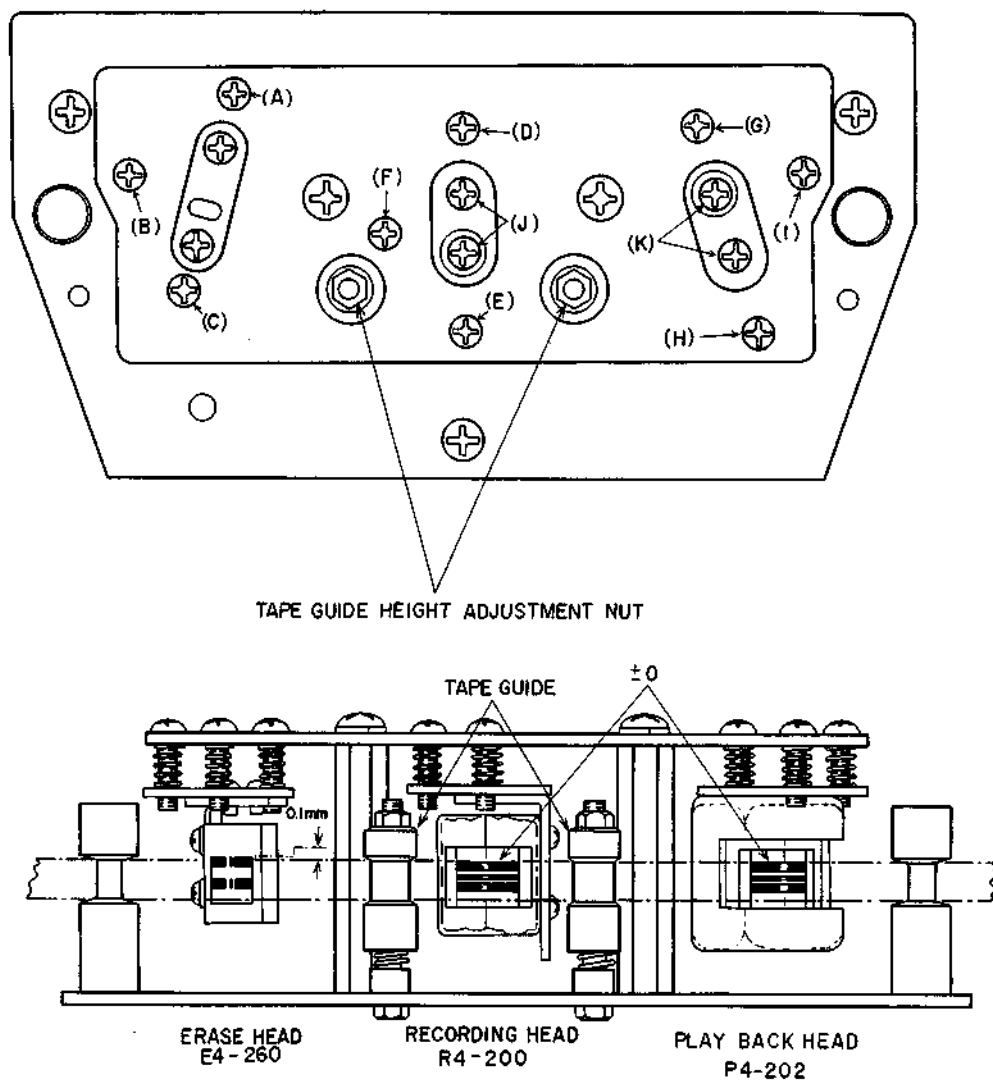

Fig. 20

Step	Adjustment Item	Test Tape & Supply Signal	MODE	Adjustment Item	Remarks
1	Tape Guide Height Adjustment	Optional	PLAY	Tape Guide Height Adjustment Nut	Adjust so that tape does not twist between tape guide on head base
2	Erase Head Height Adjustment	Optional	PLAY	(A)(B)(C)	Upper edge of channel-1 head core is 0.1 mm higher than upper edge of tape
3	Recording Head Height Adjustment	Optional	PLAY	(D)(E)(F)	Even upper edge of channel-1 head core and upper edge of tape
4	Playback Head Height Adjustment	Optional	PLAY	(G)(H)(I)	Same as Step-3 above
5	Playback Head Azimuth Alignment Adjustment	8,000 Hz 3-3/4 ips test tape	PLAY	(I)	Maximum output on both channels
6	Playback Head Gap Alignment Adjustment	8,000 Hz 3-3/4 ips test tape	PLAY	(K)	Adjust head gap surface so that there is no change in output level when tension is applied to the supply reel side
7	Recording Head Azimuth Alignment Adjustment	SCOTCH #211 tape, 15,000 Hz -20 dBm	REC	(F)	Same as Step-5 above
8	Recording Head Gap Alignment Adjustment	SCOTCH #211 Tape, 15,000 Hz -20 dBm	REC	(J)	Same as Step-6 above

Chart 1

- NOTES: 1. Demagnetize heads with head demagnetizer before and after head adjustments.  
2. Set Tape speed to 7-1/2 ips and Tape Selector to Low Noise.  
3. Set Output Control to maximum position.  
4. Refer to Fig. 20.

# VI. AMPLIFIER SYSTEM ADJUSTMENT

## 1. DC POWER SUPPLY VOLTAGE ADJUSTMENT (Refer to Fig. 21)

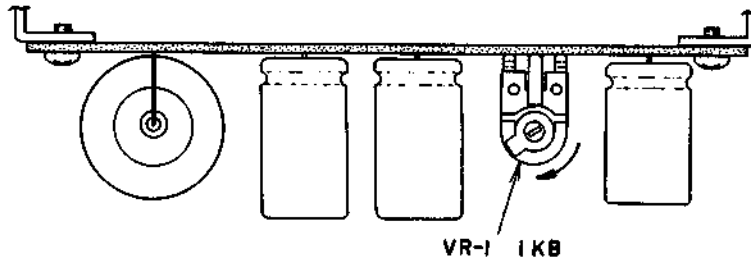

Fig. 21 Power Supply P.C Board TY-2003

## 2. TAPE SPEED ADJUSTMENT (Refer to Fig. 22)

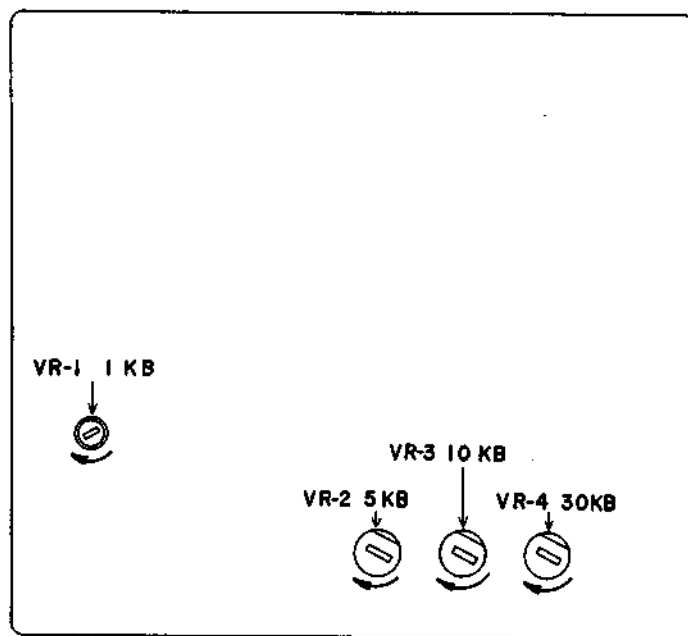

Fig. 22 Servo P.C Board TW-1049 SED

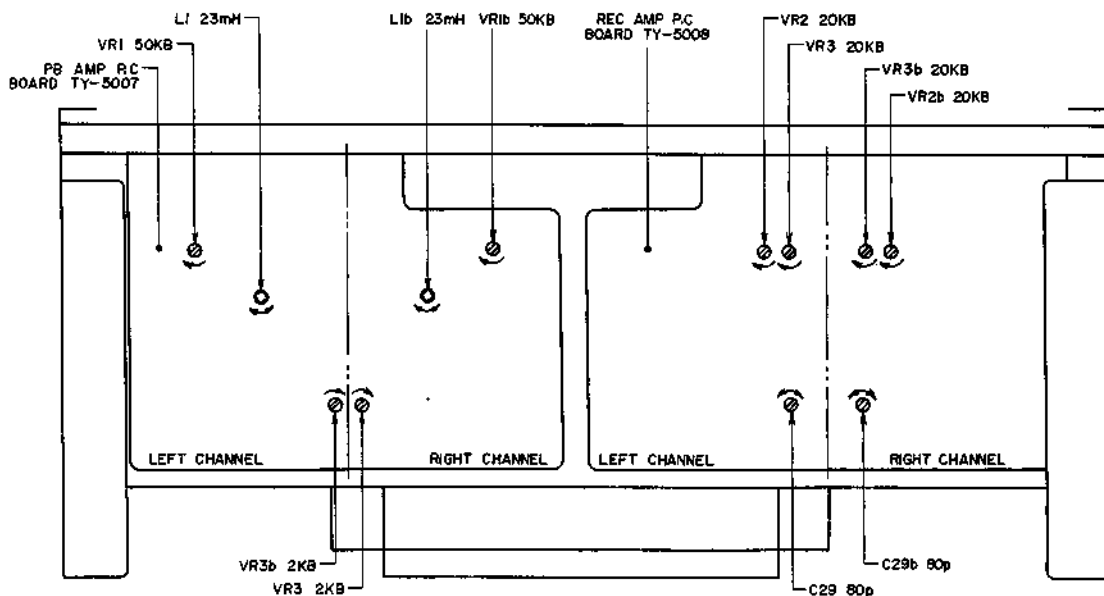

Fig. 23 Bottom View



Step	Adjustment Item	Test Tape or Supply Signal	MODE	Adjustment Point	Result	Remarks
1	DC Power Supply Voltage Adjustment	None	STOP	VR1 1 kΩ (TY-2003) See Fig. 21	DC24V	Measure at terminal "DC" of Power Supply P.C Board
2	DC Power Supply Voltage Adjustment	None	STOP	VR1 1 kΩ (TW-1049) See Fig. 22	DC21V	Measure at TR1 Emitter of Servo P.C Board
3	Tape Speed Adjustment 15 ips	1,000 Hz 7-1/2 ips Test Tape	PLAY	VR2 5 kΩ (TW-1049) See Fig. 22	2,000 Hz ±0.5%	Tape Speed to 15 ips
4	Tape Speed Adjustment 7-1/2 ips	1,000 Hz 7-1/2 ips Test Tape	PLAY	VR3 10 kΩ (TW-1049) See Fig. 22	1,000 Hz ±0.5%	Tape Speed to 7-1/2 ips
5	Tape Speed Adjustment 3-3/4 ips	1,000 Hz 7-1/2 ips Test Tape	PLAY	VR4 30 kΩ (TW-1049) See Fig. 22	500 Hz ±0.5%	Tape Speed to 3-3/4 ips
6	Playback Level Adjustment	700 Hz 7-1/2 ips 0 VU Tape	PLAY	VR1 50 kΩ (TY-5007) See Fig. 23	0 ±0.5 dB (0.775V)	
7	VU Meter Sensitivity Adjustment	700 Hz 7-1/2 ips 0 VU Tape	PLAY	VR3 2 kΩ (TY-5007) See Fig. 23	0 VU	
8	Recording Level Adjustment (Low Noise)	SCOTCH #211 Tape 1,000 Hz 0 VU recording	REC	VR2 20 kΩ (TY-5008) See Fig. 23	0 ±0.5 dB (0.775V)	Tape Selector to Low Noise
9	Recording Level Adjustment (Wide Range)	Akai LN-150 Tape 1,000 Hz 0 VU recording	REC	VR3 20 kΩ (TY-5008) See Fig. 23	0 ±0.5 dB (0.775V)	Tape Selector to Wide Range
10	Frequency Response Adjustment	SCOTCH #211 Tape 1,000 Hz & 10,000 Hz 0 VU recording	REC	C29 80P (TY-5008) See Fig. 23	1,000 Hz to 10,000 Hz flat	Tape Selector to Low Noise. Recheck recording level
11	Bias Leak Adjustment	None	REC	L1 23 mH (TY-5007) See Fig. 23	Less than -30 VU	

Chart 2

- NOTE: 1. Set Monitor Switch to "TAPE", and Output Control to Maximum.  
2. The letter "b" following an adjustment part number indicates "right" channel.

## VII. DC RESISTANCE OF VARIOUS COILS

Part	Designation	DC Resistance
Main Motor	SCM-3-16TW	Between RED-BLU 19 ohms Between YLW-GRN 90 ohms
Reel Motor	240XO-TD	Between RED-BLU 30 ohms Between YLW-GRN 157 ohms
Pinch Roller Solenoid	1660PHT2	750 ohms
Brake Solenoid	1660THT2	700 ohms
Shifter Solenoid	1254THT	620 ohms
Pick-up Coil	Built into Main Motor	3,700 ohms
Relay	MY4-O-US DC24V	650 ohms
Relay	LC1-C-JT DC24V	1,150 ohms
Relay	MTS-2	980 ohms
Headphone Output Transformer	N16-535S	Primary 565 ohms $\pm 15\%$ Secondary 0.95 ohms $\pm 15\%$
Oscillator Coil	OT-204	Between 1-3 0.3 ohms Between 4-6 0.7 ohms Between 7-9 8.2 ohms
Erase Head	E4-260	2.0 ohms
Recording Head	R4-200	8.0 ohms
Playback Head	P4-202	268 ohms

Chart 3

Note: The resistance values shown in this chart are average values.

# VIII. CLASSIFICATION OF VARIOUS P. C BOARD

## 1. RELATION OF P.C BOARD TITLE AND NUMBER

P.C Board Title	P.C Board Number
Servo Control P.C Board	TW-1049 5ED
System Control P.C Board	TY-1006
Power Supply P.C Board	TY-2003
Relay P.C Board	TY-2004
PB Amplifier P.C Board	TY-5007
Rec Amplifier P.C Board	TY-5008
TS P.C Board	TY-5010
Equalizer P.C Board	TY-5009
Stop Detection P.C Board	TY-1005

Chart 4

## 2. COMPOSITION OF VARIOUS P.C BOARDS

### 1) SERVO CONTROL P.C BOARD TW-1049 5ED

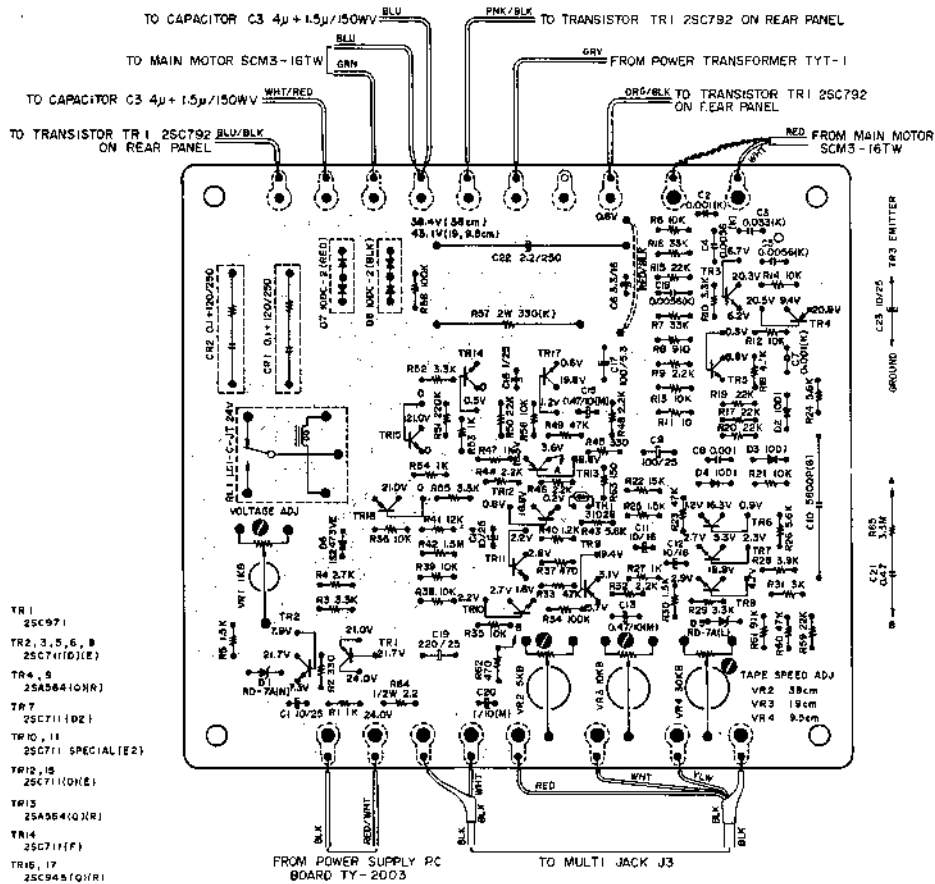

2) SYSTEM CONTROL P.C BOARD TY-1006

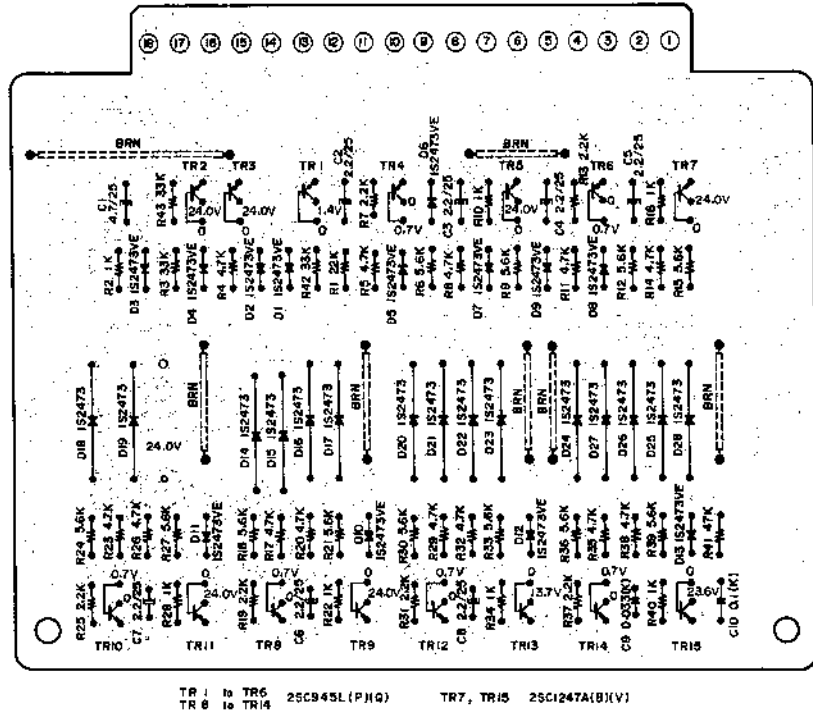

3) POWER SUPPLY P.C BOARD TY-2003

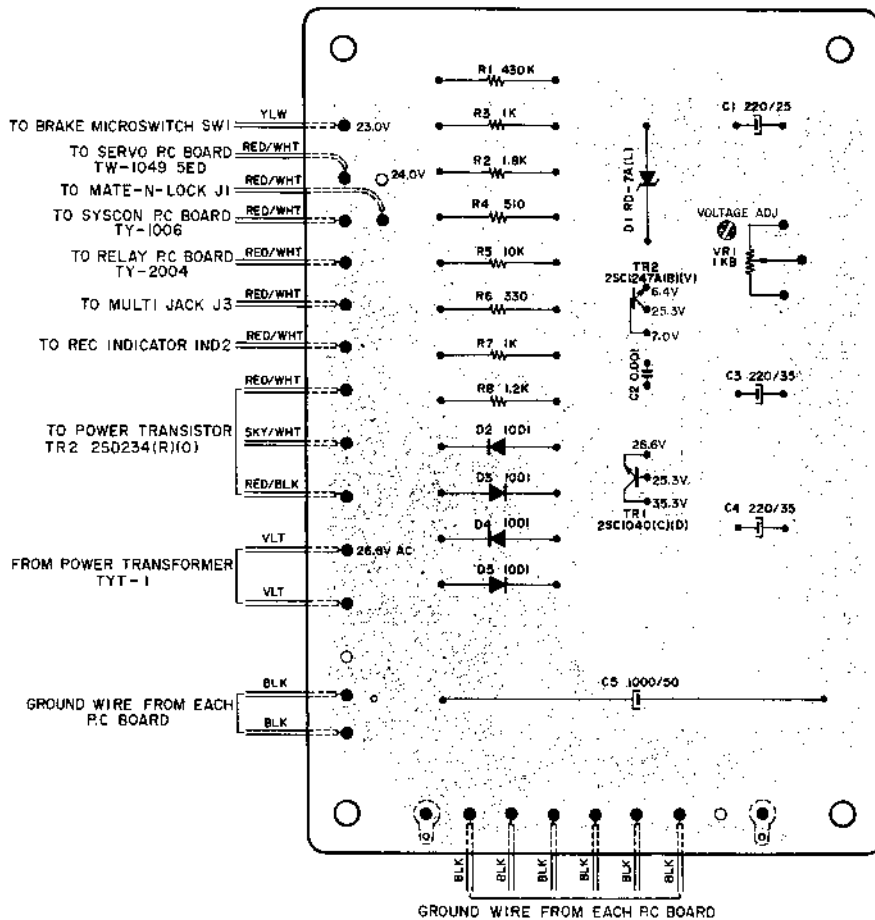

#### 4) RELAY P.C BOARD TY-2004

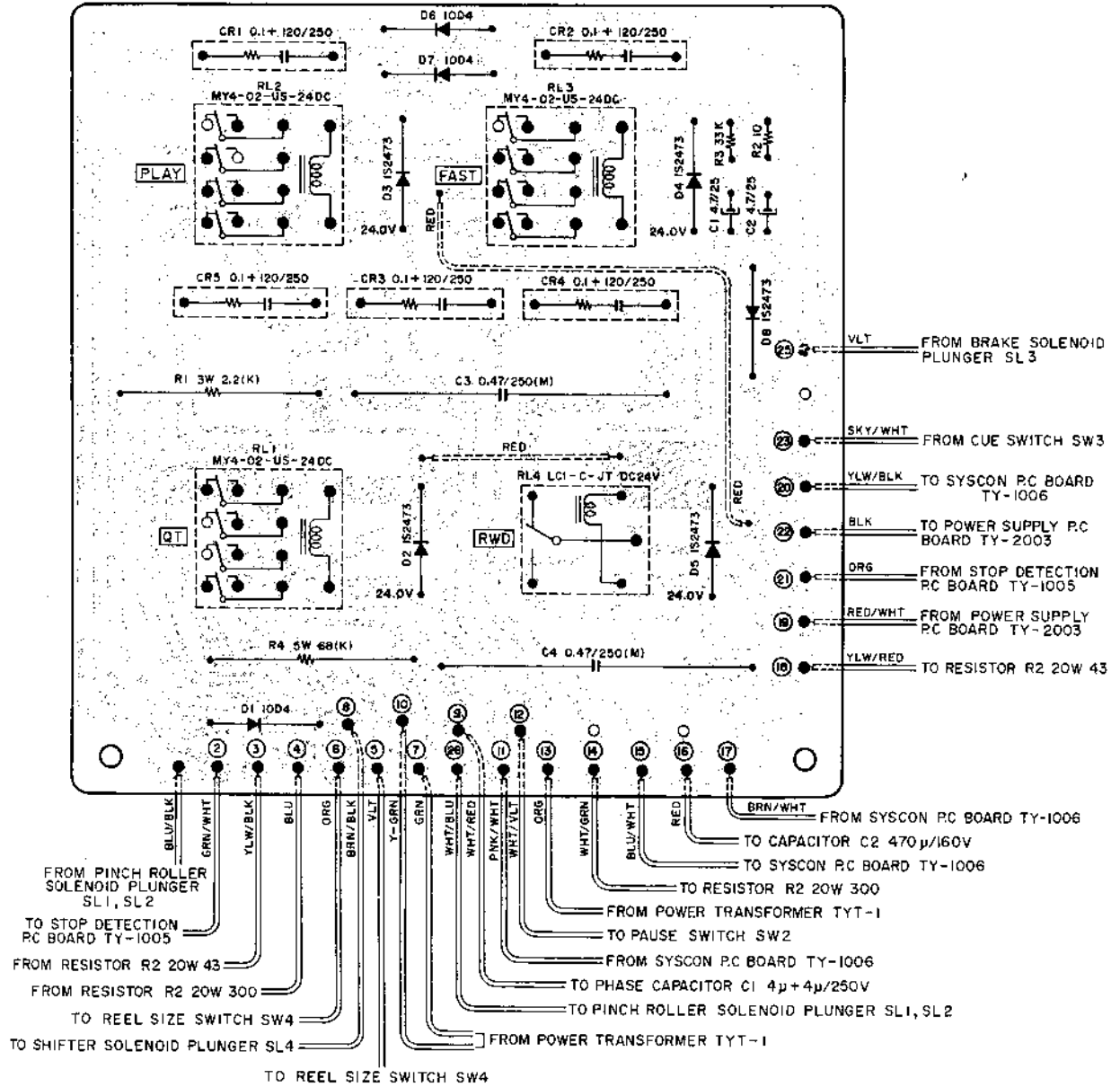

5) PB AMPLIFIER P.C BOARD TY-5007

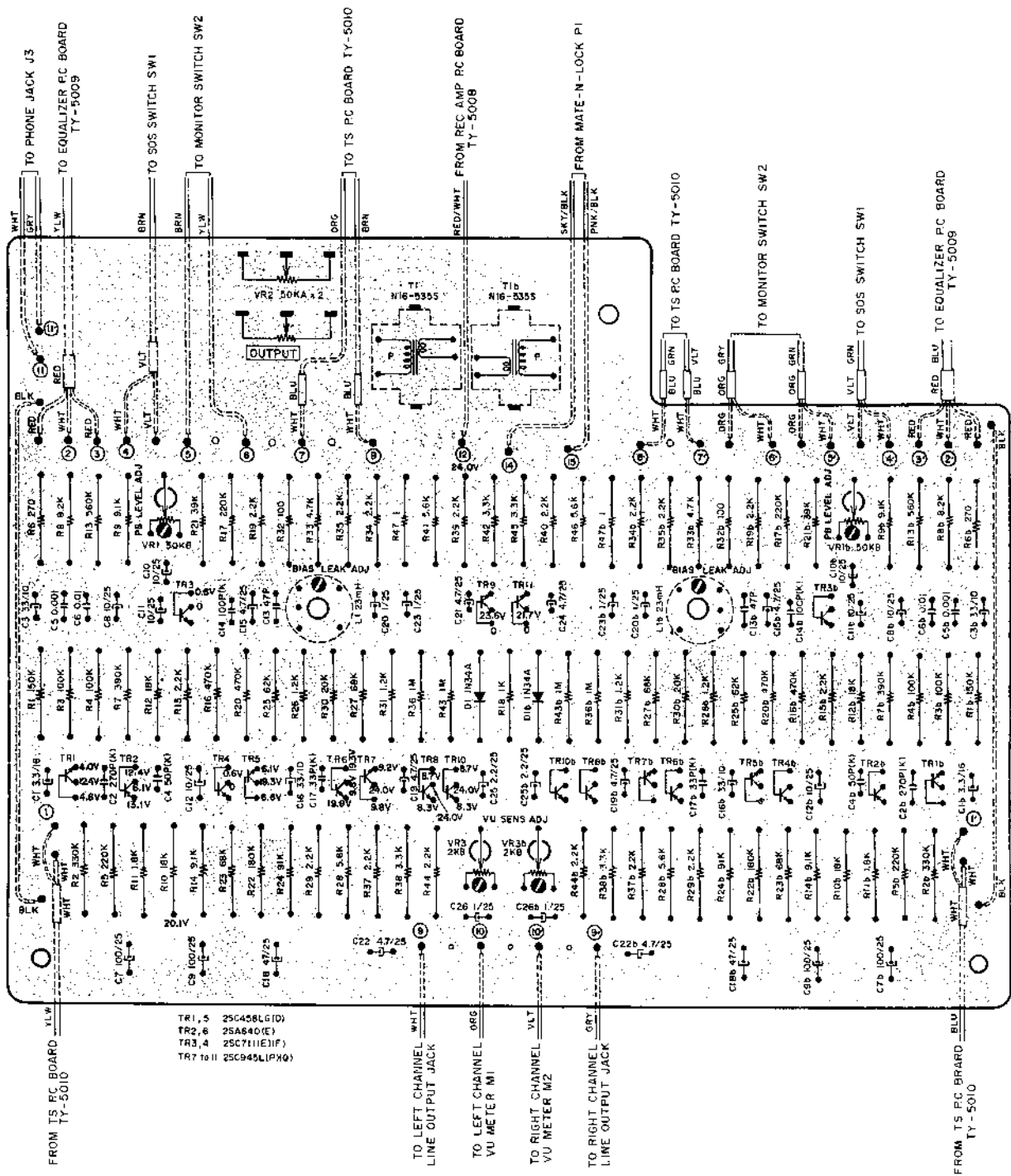

6) REC AMPLIFIER P.C BOARD TY-5008

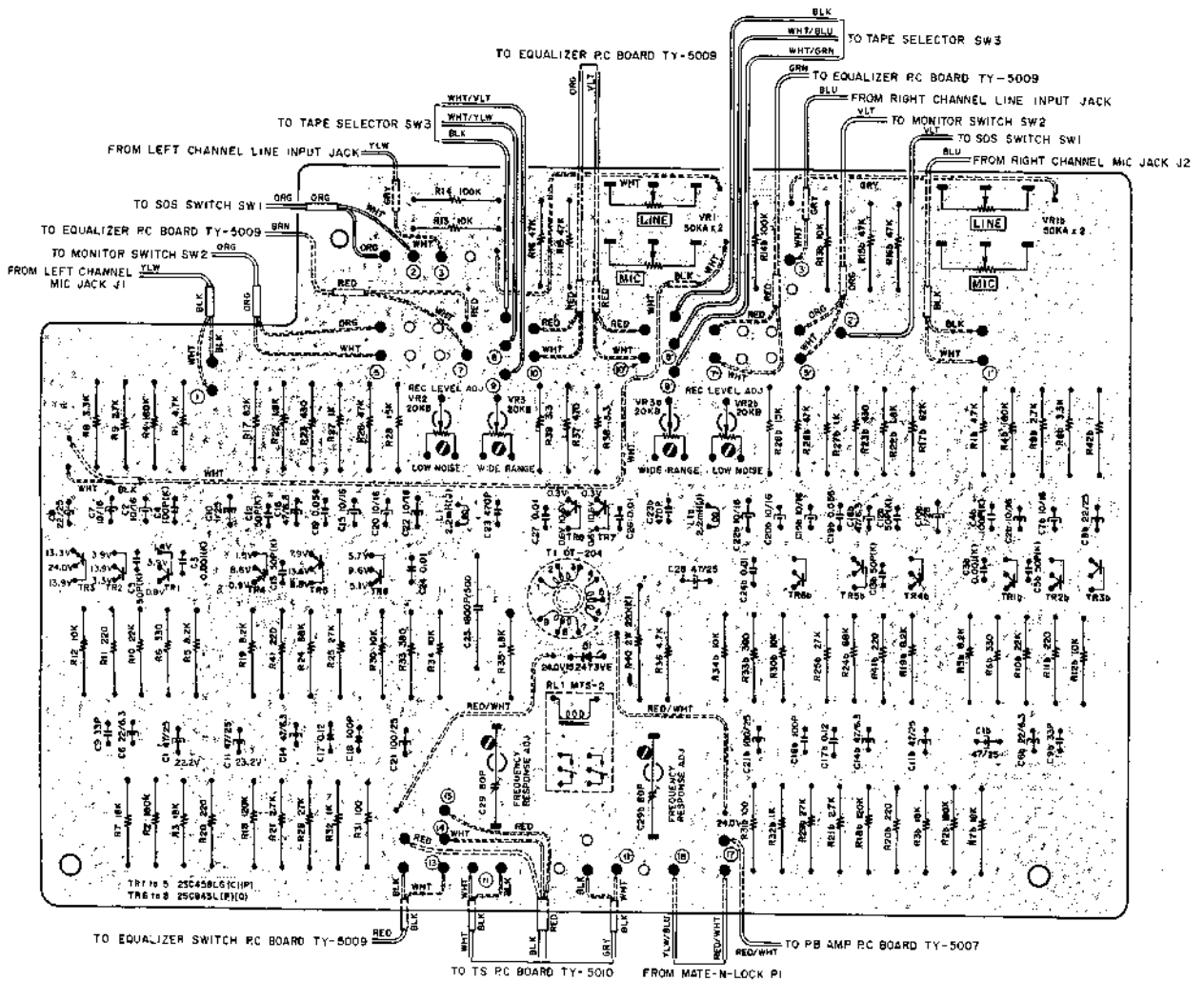

7) TS P.C BOARD TY-5010

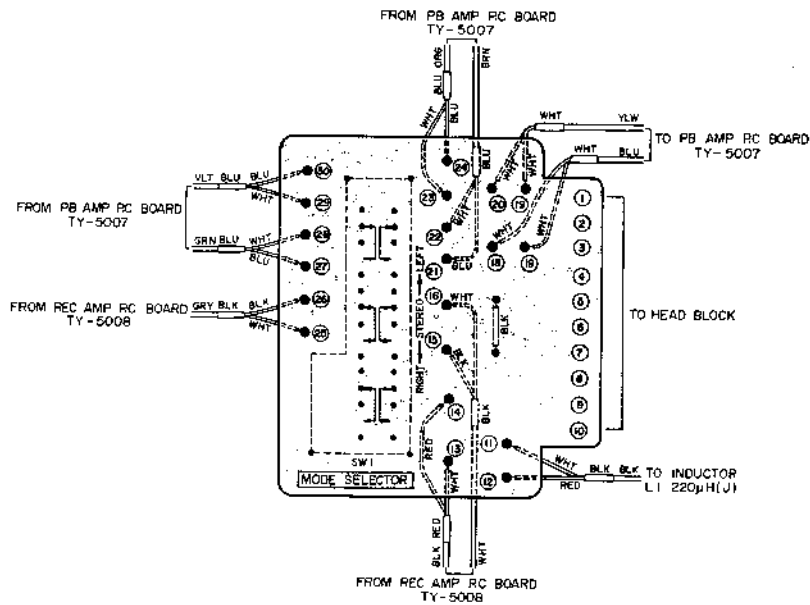

8) EQUALIZER P.C BOARD TY-5009

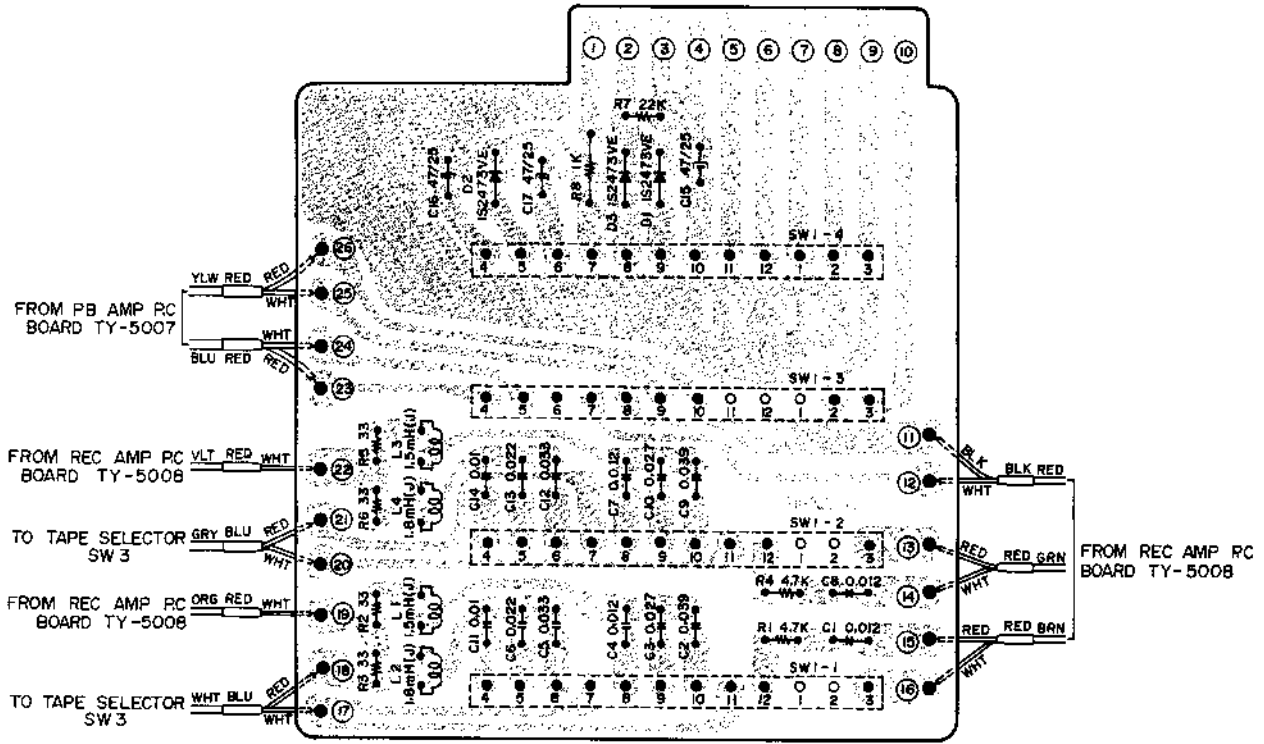

9) STOP DETECTION P.C BOARD TY-1005

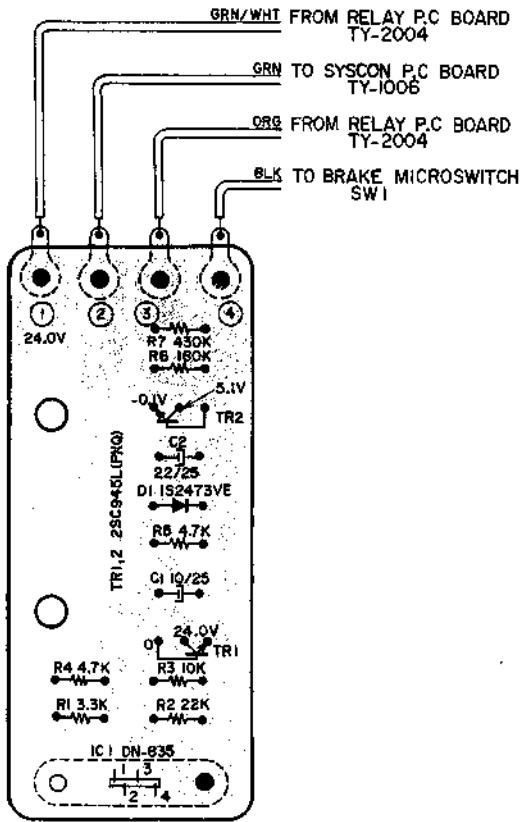











---

SECTION 2  
**PARTS LIST**

TABLE OF CONTENTS

	<b>BASIC PARTS LIST</b> .....	<b>29</b>
<b>1</b>	<b>TY HEAD BLOCK</b> .....	<b>30</b>
<b>2</b>	<b>MAIN MOTOR BLOCK</b> .....	<b>31</b>
<b>3</b>	<b>REEL MOTOR &amp; REEL TABLE BLOCK</b> .....	<b>32</b>
<b>4</b>	<b>FLYWHEEL &amp; PINCH ROLLER ARM BLOCK</b> .....	<b>34</b>
<b>5</b>	<b>TENSION ARM &amp; DAMPER BLOCK</b> .....	<b>36</b>
<b>6</b>	<b>OPERATION BLOCK</b> .....	<b>37</b>
<b>7</b>	<b>MECHANISM ASSEMBLY BLOCK</b> .....	<b>38</b>
<b>8</b>	<b>POWER SUPPLY BLOCK</b> .....	<b>40</b>
<b>9</b>	<b>P.C. BOARDS</b> .....	<b>41</b>
	(1) SERVO P.C. BOARD (TW-1049) BLOCK .....	41
	(2) SYS. CON P.C. BOARD (TY-1006) BLOCK .....	41
	(3) POWER SUPPLY P.C. BOARD (TY-2003) BLOCK .....	42
	(4) RELAY P.C. BOARD (TY-2004) BLOCK .....	42
	(5) PB P.C. BOARD (TY-5007) BLOCK .....	42
	(6) REC P.C. BOARD (TY-5008) BLOCK .....	42
	(7) TS P.C. BOARD (TY-5010) BLOCK .....	42
	(8) EQ P.C. BOARD (TY-5009) BLOCK .....	42
	(9) STOP DETECTION P.C. BOARD (TY-1005) BLOCK .....	42
<b>10</b>	<b>AMPLIFIER ASSEMBLY BLOCK</b> .....	<b>43</b>
<b>11</b>	<b>FINAL ASSEMBLY BLOCK</b> .....	<b>44</b>
<b>12</b>	<b>LIST OF INTERCHANGEABLE SEMICONDUCTORS</b> .....	<b>45</b>
	<b>INDEX</b> .....	<b>46</b>

Resistor and Capacitor which is not listed in this parts list, please refer to **COMMON LIST FOR SERVICE PARTS.**

## HOW TO USE THIS PARTS LIST

1. This parts list is compiled by various individual blocks based on assembly process.
2. When ordering parts, please describe parts number, serial number, and model number in detail.
3. How to read list.

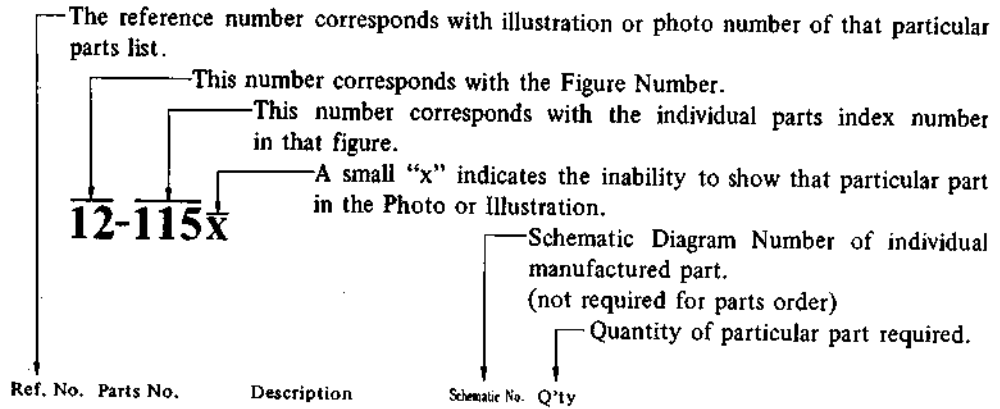

Ref. No.	Parts No.	Description	Schematic No.	Q'ty
<b>FLYWHEEL BLOCK #13</b>				
12-115x	800425	Flywheel Block Assy. Comp.	RDG #13	1
12-116	244506	Flywheel Only	RD-233	1
12-117x	244754	Felt, Flywheel	RD-275	1
12-118	251324	Main Metal Case	RD-236	1
12-119	253080	Main Metal	RD-237	1

4. The symbol numbers shown on the P.C. Board list can be matched with the Composite Views of components of the Schematic Diagram or Service Manual.
5. Please utilize separate "Common List for Service Parts" for Resistor parts orders.
6. The shape of the parts and parts name, etc. can be confirmed by comparing them with the parts shown on the Electrical Parts Table of P.C. Board.
7. Both the kind of part and installation position can be determined by the Parts Number. To determine where a parts number is listed, utilize Parts Index at end of Parts List.  
It is necessary first of all to find the Parts Number. This can be accomplished by using the Reference Number listed at right of parts number in the Parts Index. (meaning of ref. no. outlined in Item 3 above).
8. Utilize separate "Price List for Parts" to determine unit price. The most simple method of finding parts Price is to utilize the reference number.

## BASIC PARTS LIST

Parts Nomenclature	Parts No.
Case TY-6010	BC662670
Mecha Panel TY-6001	BZ662681
Amp Panel TY-6006	SP643702
VU Escutcheon MY-6205	SE631102
VU Meter KL-250B-28C (Yellow)	EM573748
Selector Knob TY-6014	SK643612
Double Knob (Upper) TY-6008	SK639987
Double Knob (Lower) TY-6009	SK639977
Equalizer P.C Board TY-5009	BA662940
PB Amplifier P.C Board TY-5007	BA662938
Recording Amplifier P.C Board TY-5008	BA662727
System Control P.C Board TY-1006	BA662848
Power Supply P.C Board TY-2003	BA662826
Relay P.C Board TY-2004	BA662837
TS P.C Board TY-5010	BA662951
Servo Control P.C Board TW-1049	BA552407
Stop Detection P.C Board TY-1005	BA662905
Operation Block	BZ662850
Damper Block	BZ662872
Tension Arm Block (Left)	BL662894
Tension Arm Block (Right)	BL662883
Reel Motor 24XO-TD	BM662747
Main Motor SCM3-16TW	BM662736
Lever Switch S-J6308	ES641226
Lever Switch S-J6398	ES641215
Lever Switch S-J1915	ES647458
Rotary Switch SRE-4143	ES641125
Power Transformer TYT-1	BT641182
Power Transformer TYT-2	BT647561
Power Transformer TYT-3	BT647538
Hall IC DN-835	EI620640

# 1. ILLUSTRATION OF TY HEAD BLOCK

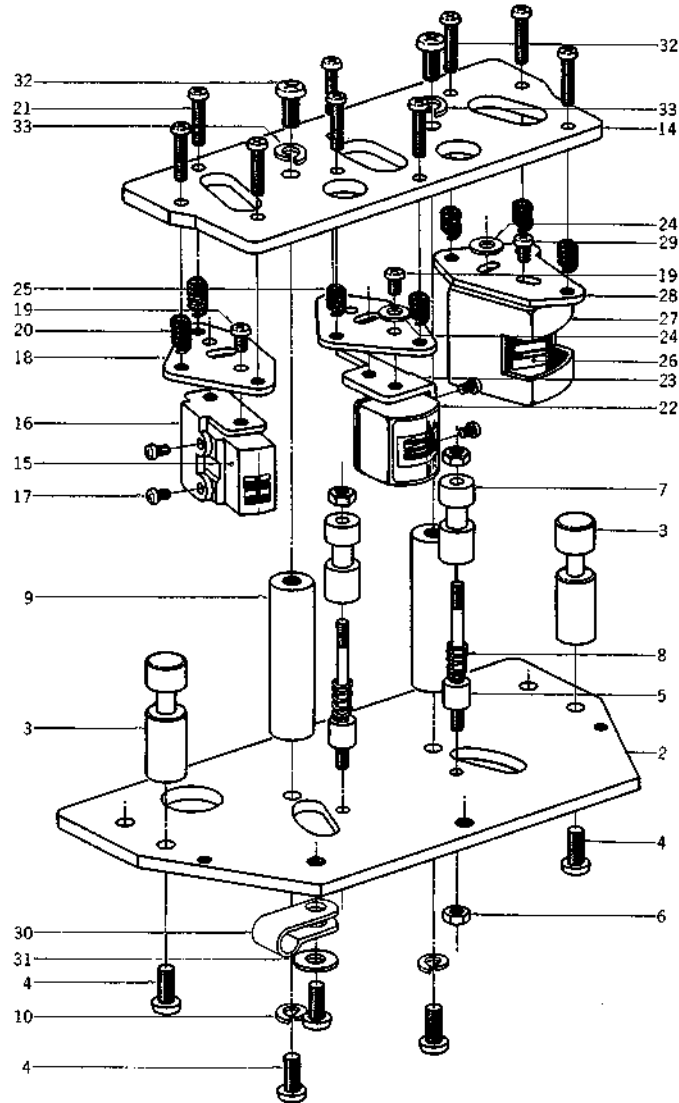

## 1) TY HEAD BLOCK

Ref. No.	Parts No.	Description	Schematic No.	Q'ty	Ref. No.	Parts No.	Description	Schematic No.	Q'ty
1-1x	BH662771	Head Block Comp.	TY	1	1-21	ZS608501	Screw, pan head 3x12		9
1-2	HZ643634	Head Base B	TY-0002	1	1-22	HR384513	REC HEAD R4-200	LF3,TD	1
1-3	HZ532708	Tape Guide A	TW-0005	2	1-23	HA533597	RH Angle	TW-0201	1
1-4	ZS413201	Screw, pan head 4x8		5	1-24	ZW413256	Washer (SPC) D3.4x7.8x0.5t		2
1-5	HZ532697	Tape Guide Prop A	TW-0004	2	1-25	ZG364656	Angle Adjust Spring C	RD-57	6
1-6	ZW273756	Nut M3		4	1-26	HP552194	PB HEAD P4-220	TW1.2	1
1-7	HZ532710	Tape Guide B	TW-0006	2	1-27	HZ532776	Shield Case	TW-0011	1
1-8	ZG466312	Angle Adjust Spring E	BS-0018	2	1-28	HZ532765	PH Retaining Base	TW-0010	1
1-9	MH529233	Head Base Prop B	ND-0017	2	1-29	ZS396000	Screw, binding head 3x4		2
1-10	ZW273914	Spring Washer M4		4	1-30	EJ315101	Nylon Clip HP-4N	2-7-38	1
1-11x	EA463206	Terminal P.C Board A	RD-A36	1	1-31	ZW562757	Washer (SPC) D4.3x11x0.8t		1
1-12x	EA466547	Terminal P.C Board B	KD-A0013	1	1-32	ZS201778	Screw, pan head 4x8		2
1-13x	EA540573	Terminal P.C Board C	RD-A36	2					
1-14	HZ643623	Head Base A	TY-0001	1					
1-15	HE563220	ERASE HEAD E4-260	TW3,MY3	1					
1-16	HA533608	EH Angle	TW-0202	1					
1-17	ZS201475	Screw, pan head 2x3		6					
1-18	HZ532732	CH Retaining Base	TW-0008	2					
1-19	ZS608477	Screw, pan head 3x4		4					
1-20	ZG382757	Angle Adjust Spring D	RD-A12	3					

When ordering parts, please describe Parts Number, Serial Number, and Model Number in detail



## 2. ILLUSTRATION OF MAIN MOTOR BLOCK

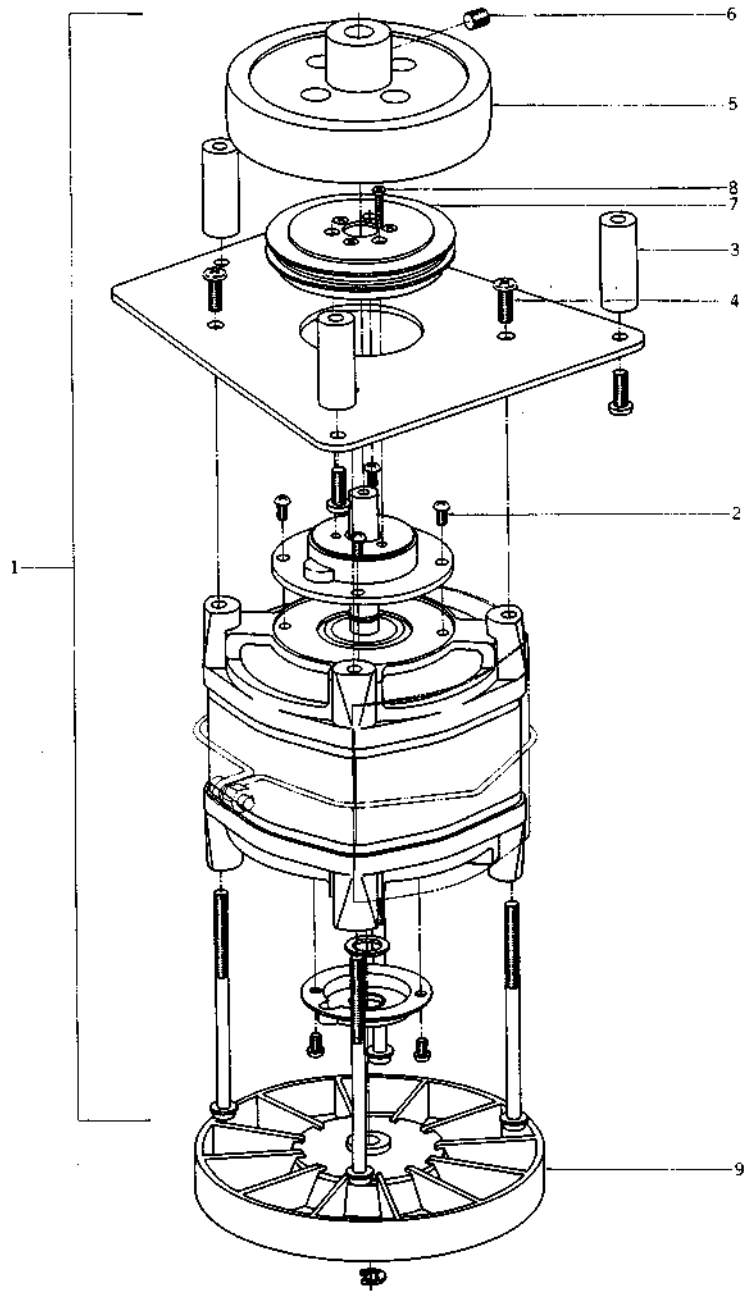

### 2) MAIN MOTOR BLOCK

Ref. No.	Parts No.	Description	Schematic No.	Q'ty	Ref. No.	Parts No.	Description	Schematic No.	Q'ty
2-1	BM662736	Main Motor Block Comp.	TW.TY	1	2-9	MZ450720	Motor Fan	BS-7015	1
2-2	ZS384131	Screw, round head 3x5		4	2-10x	ZW270123	'E' Ring 4M	6-1-9	1
2-3	MH532462	Motor Prop	TW-7019	3	2-11x	ZW290250	U Type Speed Nut M4 #1 (large)	6-3-2	6
2-4	ZS424056	Screw, pan head 4x10		3					
2-5	MR532440	Pulley	TW-7017	1					
2-6	ZS459033	Set Screw, hexagon socket 5x5 (Cup/P.)		2					
2-7	BZ556694	Detector Gear Block Comp.	TW.TY	1					
2-8	ZS537974	Screw, countersunk head 2x12		3					

When ordering parts, please describe Parts Number, Serial Number, and Model Number in detail

3. ILLUSTRATION OF REEL MOTOR & REEL TABLE BLOCK

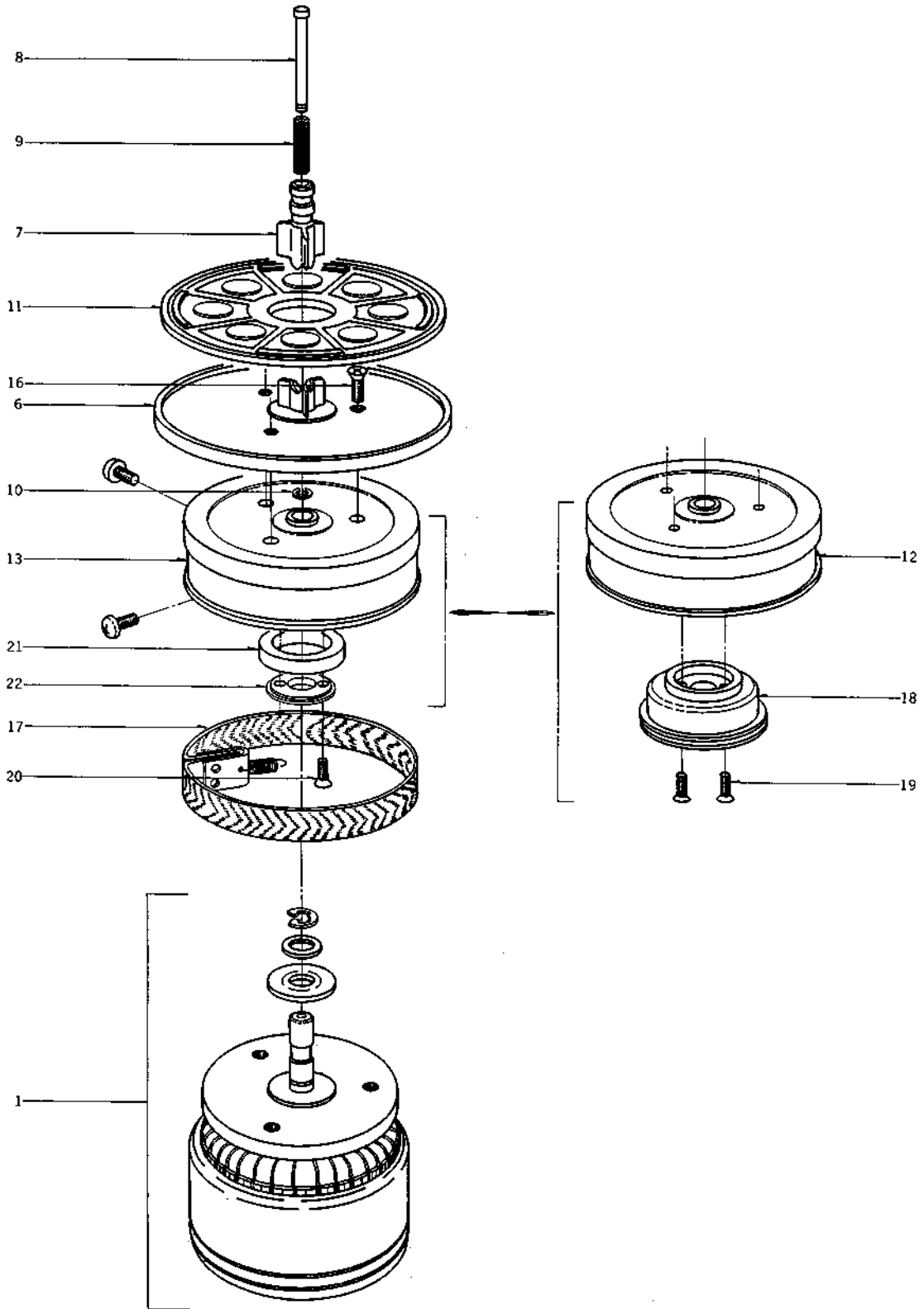

3) REEL MOTOR  
& REEL TABLE BLOCK

Ref. No.	Parts No.	Description	Schematic No.	Q'ty
<b>REEL MOTOR BLOCK</b>				
3-1	BM662747	Reel Motor Block Comp.	TD, TE, TY	1
3-2x	ZW334258	Washer (SUP) D4.1x13x0.5t		4
3-3x	ZS413234	Screw, pan head 4x12		4
<b>REEL TABLE (L) (R) BLOCK</b>				
3-4x	BR552328	Reel Table (R) Block Comp.	TW, TY	1
3-5x	BR662861	Reel Table (L) Block Comp.	TY	1
3-6	MT534666	Reel Table	TW-2031	1
3-7	MT534677	Reel Clamper	TW-2032	1
3-8	MS342000	Reel Shaft	3R-108	1
3-9	ZG540617	Clamper Spring	TW-2096	1
3-10	ZW270088	'E' Ring 1.9M	6-1-9	1
3-11	MT534688	Reel Table Rubber	TW-2033	1
3-12	MT632621	Brake Drum (Right) B	KH-2031	1
3-13	MT632654	Brake Drum (Left) C	KH-2031	1
3-14x	ZW562476	Earth Lug M3		1
3-15x	ZS425981	Screw, binding head 3x3		1
3-16	ZS425103	Screw, countersunk head 3x10		3
3-17	MT436860	Brake Cloth Comp.	MR-269	1
3-18	MR534690	Counter Pulley (R)	TW-2034	1
3-19	ZS433315	Screw, countersunk head 2.3x8 (R)		2
3-20	ZS516655	Screw, countersunk head 2.3x8 (L)		2
3-21	MZ641193	Ferrite Magnet (L)	37-1-73	1
3-22	MZ639922	Magnet Holder (L)	TY-2012	1

4. ILLUSTRATION OF FLYWHEEL & PINCH ROLLER ARM BLOCK

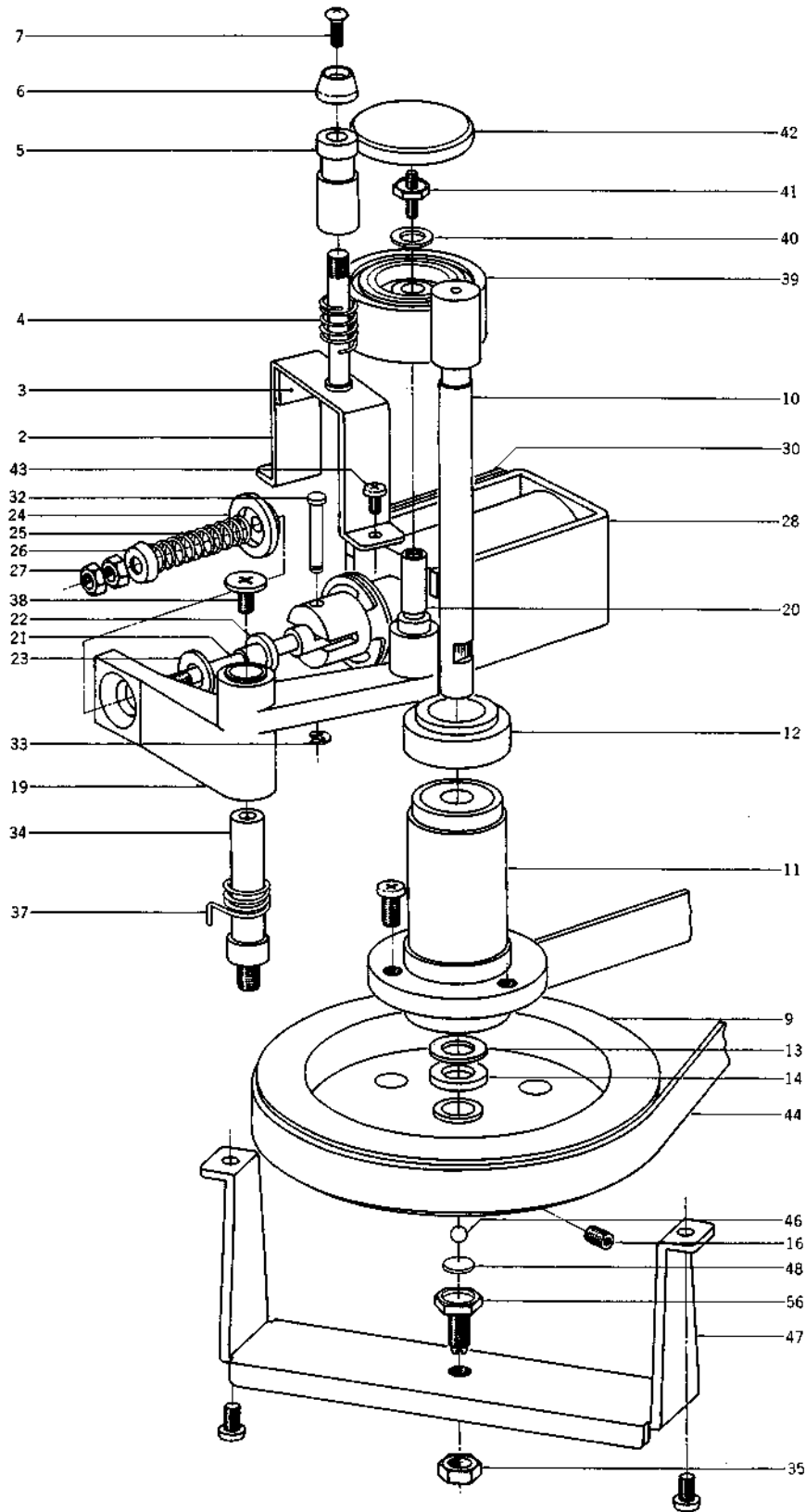

#### 4) FLYWHEEL

#### & PINCH ROLLER ARM BLOCK

Ref. No.	Parts No.	Description	Schematic No.	Qty
<b>TAPE GUIDE BLOCK</b>				
4-1x	BZ552385	Tape Guide Block Comp.	TW, TY	1
4-2	MZ535116	Guide Base, w/prop	TW-2079	1
4-3	ZG535162	Guide Spring B	TW-2083	1
4-4	MS535173	Tape Guide D	TW-2084	1
4-5	ZW535217	Guide Adjust Nut	TW-2088	1
4-6	ZS203084	Screw, oval countersunk head 3x8		1
<b>FLYWHEEL BLOCK</b>				
4-7x	BF552330	Flywheel Block Comp.	TW, TY	1
4-8	ML534734	Flywheel	TW-2040	1
4-9	MS534723	Capstan Shaft	TW-2038	1
4-10	MZ534701	Main Case, w/metal	TW-2035	1
4-11	MZ534745	Main Case Cap	TW-2042	1
4-12	ZW260245	Washer (Nylon) D7.9x13x1t		1
4-13	MZ549720	Main Case Felt	TW-2097	1
4-14x	ZW564276	'C' Ring (Hole) RTW-18		1
4-15x	ZS687126	Set Screw, hexagon socket 5x5 (Flat/p.)		2
4-16x	VT360090	Capstan Felt	PX-217	1
<b>PINCH ROLLER ARM (L) (R) BLOCK</b>				
4-17x	ML533845	Pinch Roller Arm A (R)	TW-2001	1
4-18	ML533856	Pinch Roller Arm B (L)	TW-2003	1
4-19	MS533867	Pinch Roller Shaft	TW-2005	1
4-20	ML533878	Pull Bar	TW-2006	1
4-21	MZ533880	Collar	TW-2007	1
4-22	ZW533891	Washer (Rubber)	TW-2008	1
4-23	ZW533902	Spring Washer	TW-2009	1
4-24	ZG243257	Pinch Roller Compression Spring	3A-346	1
4-25	MZ802980	Spring Holder	RD-276	1
4-26	ZW416698	Nut M4		2
4-27	EP538457	Plunger Solenoid 1660PHT 2	44-1-56	1
4-28x	ED224550	Silicon Diode 10D4 (R)	45-2-16	1
4-29x	ZS379405	Screw, binding head 3x6		2
4-30	MH533913	Connecting Pin	TW-2010	1
4-31	ZW270088	'E' Ring 1.9M	6-1-9	2
4-32	MS532956	Pinch Roller Arm Shaft	TW-1006	2
4-33	ZW413278	Nut M5		4
4-34x	ZG533700	Pinch Arm Spring A(R)	TW-1036	1
4-35	ZG533711	Pinch Arm Spring B(L)	TW-1037	1
4-36	ZS243516	Screw, pinch roller arm	XR-140	2
4-37	MP676888	Pinch Roller TY D=36	TW-1040	2
4-38	ZW260076	Washer (Nylon) D6.1x10x0.5t		2
4-39	ZS533766	Pinch Roller Screw	TW-1042	2
4-40	SK632610	Pinch Roller Cap B	TW-6019	2
4-41	ZS323728	Screw, binding head 3x5		2
4-42	MB533070	Flat Belt D241.5x1.6	TW-1020	1
4-43x	ZS413201	Screw, pan head 4x8		6
4-44	MV269965	Steel Ball D4		2
4-45	MZ692875	Supporting Plate	TW-1063	2
4-46	ZW462205	Washer (Nylon) D7.9x1t (without hole)		2
4-47x	ZS416687	Screw, binding head 4x8		4
4-48x	ZW330412	Adjust. Washer (U) D4x13x0.13t		2
4-49x	ZW330423	Adjust. Washer (U) D4x13x0.25t		2
4-50x	ZW330434	Adjust. Washer (U) D4x13x0.5t		2
4-51x	ZW330445	Adjust. Washer (U) D4x13x0.8t		2
4-52x	ZW560215	Washer (Teflon) D6.1x10x0.5t		2
4-53x	ZW560226	Washer (PBP) D6.1x10x0.2t		2
4-54	MZ585900	Shaft Support	LS-1203	2

When ordering parts, please describe Parts Number, Serial Number, and Model Number in detail

## 5. ILLUSTRATION OF TENSION ARM & DAMPER BLOCK

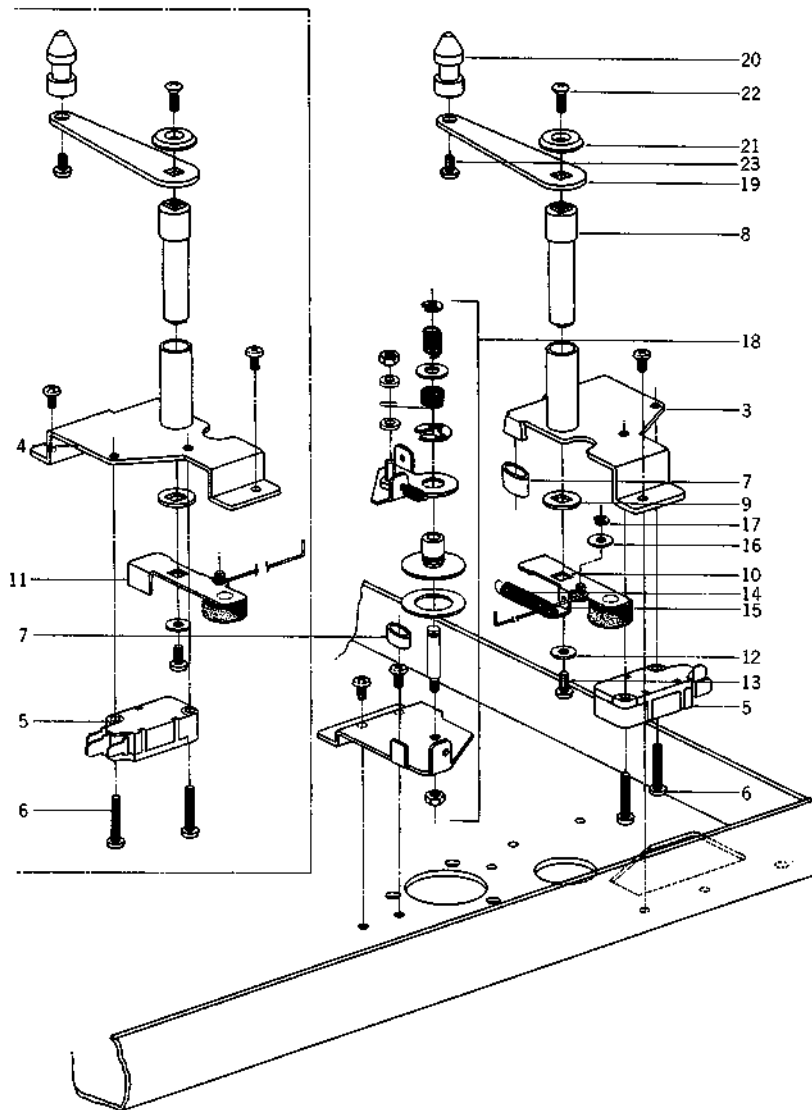

### 5) TENSION ARM & DAMPER BLOCK

Ref. No.	Parts No.	Description	Schematic No.	Q'ty	Ref. No.	Parts No.	Description	Schematic No.	Q'ty
<b>TENSION ARM BLOCK</b>									
5-1x	BL662883	Tension Arm (R) Block Comp.	TY	1	5-12	ZW425002	Washer (SPC) D3.1x8x0.5t		1
5-2x	BL662894	Tension Arm (L) Block Comp.	TY	1	5-13	ZS379405	Screw, binding head 3x6		1
5-3	MZ534903	Tension Arm Table A, w/metal (R)	TW-2059	1	5-14	ZG535105	Tension Arm Spring	TW-2078	1
5-4	MZ534914	Tension Arm Table B, w/metal (L)	TW-2059	1	5-15	MZ639955	Damper Wire	TY-2015	1
5-5	ES573478	Micro SW. K-3	25-J-31	1	5-16	ZW550642	Washer (SPC) D3.1x7.9x0.5t		1
5-6	ZS417148	Screw, binding head 3x15		2	5-17	ZW270088	'E' Ring 1.9M	6-1-9	1
5-7	MZ810191	Cushion Rubber, RD	RD-278	2	5-18x	BZ662872	Damper Block Comp.	TY	1
5-8	MS534936	Tension Shaft A	TW-2061	1	5-19	ML535037	Tension Arm	TW-2076	2
5-9	ZW534982	Tension Arm Washer	TW-2055	1	5-20	MS533147	Tape Guide C	TW-2072	2
5-10	ML534960	Tension SW. Lever A, w/weight (R)	TW-2064	1	5-21	ZW535094	Decorative Washer	TW-2077	2
5-11	ML534971	Tension SW. Lever B, w/weight (L)	TW-2064	1	5-22	ZS203084	Screw, oval countersunk head 3x8		2
					5-23	ZS413212	Screw, binding head 3x5 w/lug		2

When ordering parts, please describe Parts Number, Serial Number, and Model Number in detail

## 6. ILLUSTRATION OF TENSION ARM & DAMPER BLOCK

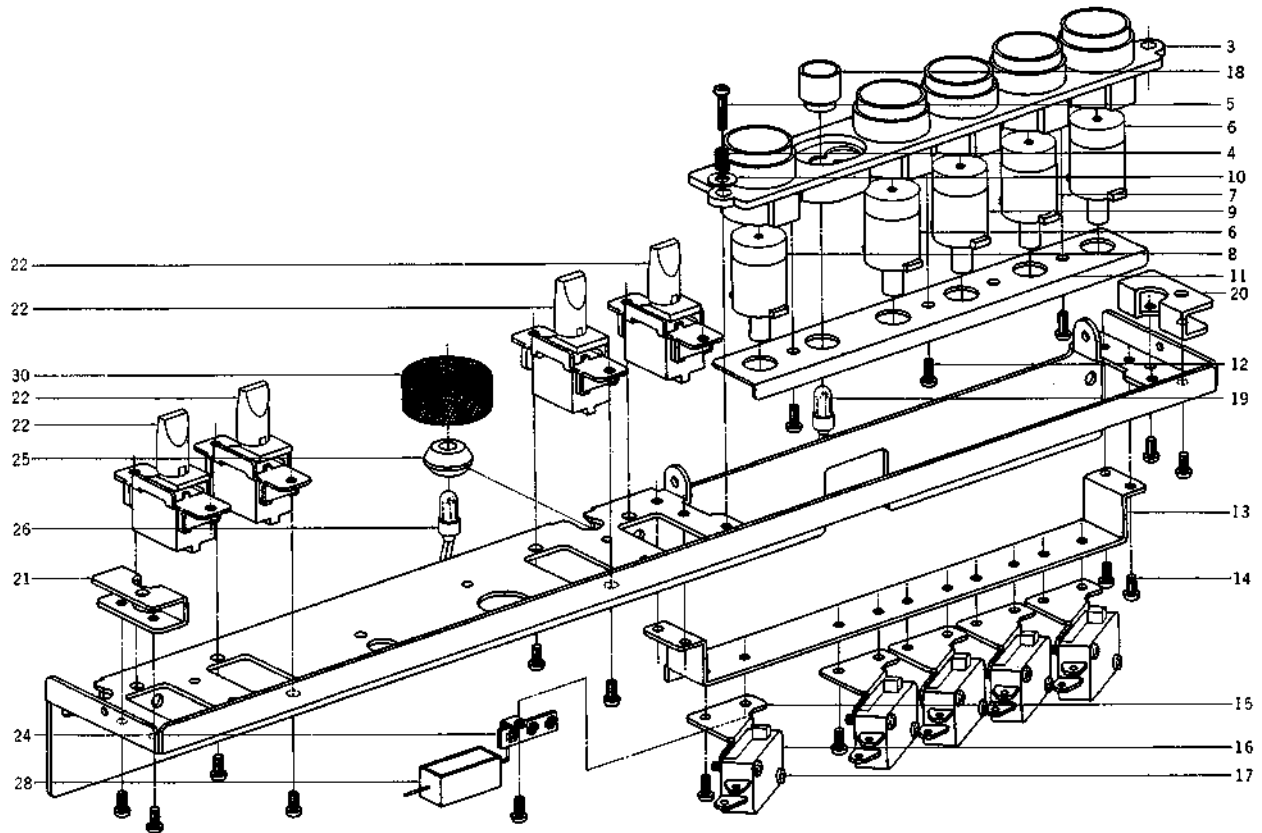

### 6) OPERATION BLOCK

Ref. No.	Parts No.	Description	Schematic No.	Q'ty	Ref. No.	Parts No.	Description	Schematic No.	Q'ty
6-1x	BZ662850	Operation Block Comp.	TY	1	6-26	EL443520	Lamp (Cord Type) 8V 80MA (60M/Mx2)	28-2-22	1
6-2x	BZ681906	Operation Block Comp. (CEE)	TY	1	6-27x	EC551160	Ceramic/C. NB821YZ 0.01μF(Z) 1.4 kWV	24-5-55	2
6-3	MZ643678	Operate Button Holder	TY-2005	1	6-28	ER554556	Cement/R. (Wire-wound Type) 5W 39 ohms(K)	35-16-3	1
6-4	ZG382757	Angle Adjust Spring D	RD-A12	2	6-29x	ER430222	Carbon/R. (Insu. Type) RD1/4W 33 ohms(J)	35-9-5	1
6-5	ZS419670	Screw, pan head 3x12		2	6-30	TC494267	Lamp Cover	CG-2206	1
6-6	SB639832	Operate Button A	TY-2006	2					
6-7	SB639843	Operate Button B	TY-2006	1					
6-8	SB639854	Operate Button C	TY-2006	1					
6-9	SB639865	Operate Button D	TY-2006	1					
6-10	ZW425002	Washer (SPC) D3.1 x8x0.5t		1					
6-11	SZ639887	Button Stopper	TY-2008	1					
6-12	ZS325495	Tapping Screw #2 3x6 (BR)		3					
6-13	MZ643680	Operate SW. Table	TY-2009	1					
6-14	ZS422076	Screw, pan head 3x5		29					
6-15	MZ639898	Micro SW. Angle	TY-2010	5					
6-16	ES250075	Micro SW. V-1A10 U/L	25-1-8	5					
6-17	ZS419670	Screw, pan head 3x12		10					
6-18	EZ586326	Lamp Holder	LF-5324	1					
6-19	EL666292	Lamp (Cord Type) 24V 35MA(60M/Mx2)	28-2-24	1					
6-20	SZ639900	Panel Support A	TY-2011	1					
6-21	SZ639911	Panel Support B	TY-2011	1					
6-22	ES647458	Lever SW. S-J1915	25-4-26	4					
6-23x	ES205110	Lever SW. JL-15 (CEE)	25-4-27	1					
6-24	EJ255115	Lug Plate VB2L2	33-4-3	1					
6-25	EZ428117	Rubber Bushing	AA-861	1					

When ordering parts, please describe Parts Number, Serial Number, and Model Number in detail

# 7. ILLUSTRATION OF MECHANISM ASSEMBLY BLOCK

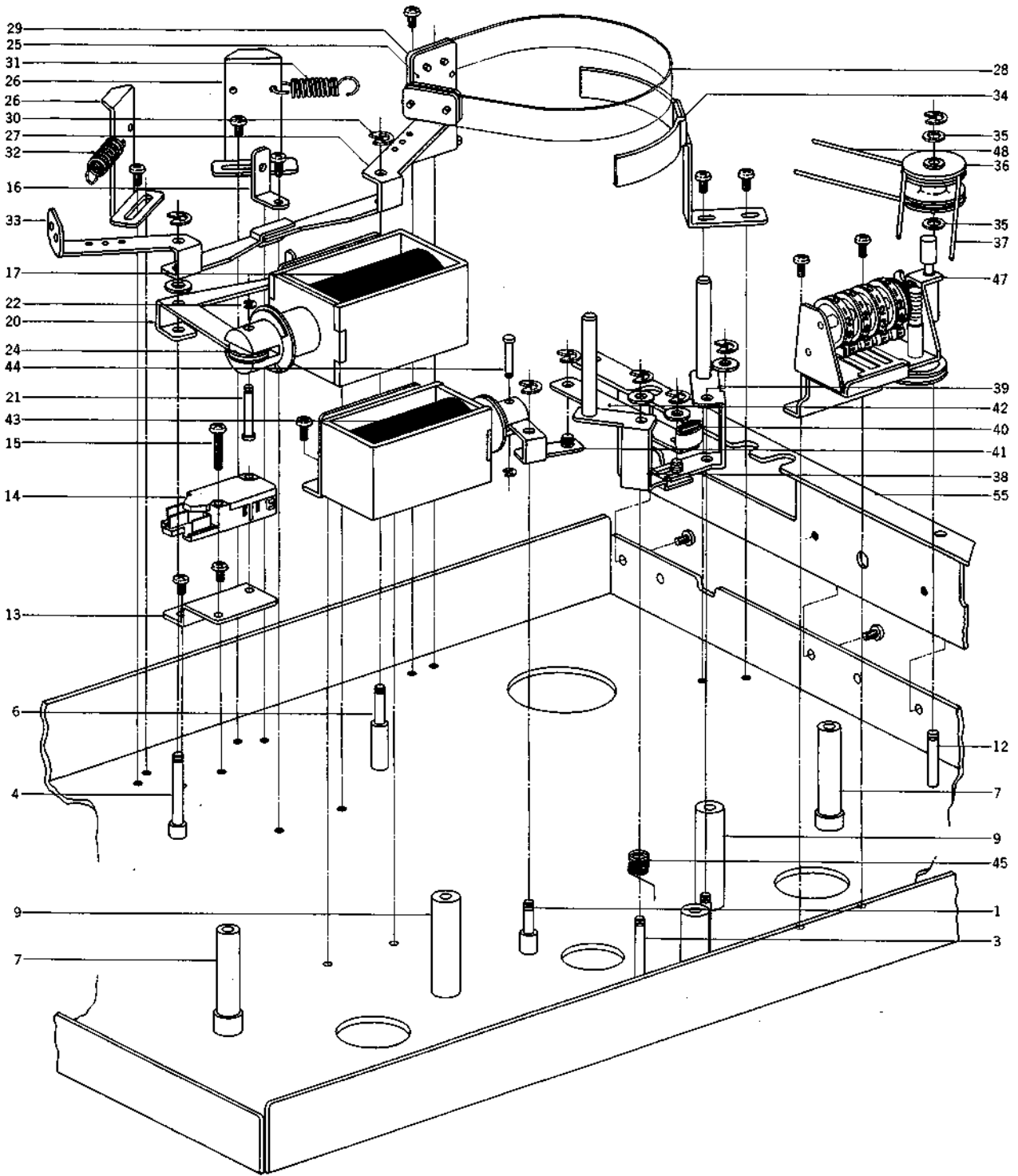



## 7) MECHANISM ASSEMBLY BLOCK

Ref. No.	Parts No.	Description	Schematic No.	Q'ty
7-1	MH532912	Shifter Lever Prop A	TW-1002	1
7-2x	ZW516993	Nut M3		4
7-3	MH532923	Shifter Lever Prop B	TW-1003	2
7-4	MH532934	Brake Lever Prop A	TW-1004	1
7-5x	ZW413188	Nut M4		2
7-6	MH532945	Brake Lever Prop B	TW-1005	1
7-7	MS532956	Pinch Roller Arm Shaft	TW-1006	2
7-8x	ZW413278	Nut M5		2
7-9	MH532978	Head Base Prop	TW-1008	3
7-10x	ZS416687	Screw, binding head 4x8		3
7-11x	ZW273914	Spring Washer M4		3
7-12	MS532980	Pulley Shaft	TW-1009	1
7-13	MZ533035	QT SW. Base	TW-1015	1
7-14	ES562465	Micro SW. K-1	25-1-26	1
7-15	ZS483502	Screw, pan head 3x13		2
7-16	MZ237418	Hum Backing Coil Metal Fitting (L Type)	M8-103	1
7-17	EP537906	Plunger Solenoid 1660THT2	44-1-54	1
7-18x	ZS379405	Screw, binding head 3x6		2
7-19x	ED224550	Silicon Diode 10D4	45-2-16	2
7-20	ML533654	Brake Lever C	TW-1031	1
7-21	MH533913	Connecting Pin	TW-2010	1
7-22	ZW270088	'E' Ring 1.9M	6-1-9	3
7-23x	ZS323728	Screw, binding head 3x5		28
7-24	ZW561486	Washer (BSP) D4.1x13x0.8t		2
7-25	MZ533665	Brake Band Support	TW-1032	2
7-26	MZ543025	Brake Adjust. Plate	TW-1061	2
7-27	ML533632	Brake Lever A	TW-1029	1
7-28	MT314987	Brake Band	MR-213	2
7-29	MZ314998	Brake Band Retaining Plate	MR-212	4
7-30	ZW290283	'U' Ring 2.85M	6-1-1	6
7-31	ZG540090	Brake Lever Spring	TW-1058	2
7-32x	ZW382162	Washer (SPC) D4.1x11x0.25t		1
7-33	ML533643	Brake Lever B	TW-1030	1
7-34	MZ533687	Brake Band Guide Table, w/guide	TW-1034	2
7-35	ZW259773	Washer (Nylon) D4.1x7x0.5t		2
7-36	MR533002	Middle Pulley (Counter), w/metal	TW-1012	1
7-37	MB533057	Counter Belt A D119.1x1.4	TW-1018	1
7-38	ML639808	Shifter Lever B, w/pin	TY-1002	1
7-39	ML639797	Shifter Lever A, w/pin	TY-1001	1
7-40	MZ810191	Cushion Rubber, RD	RD-278	1
7-41	ML533081	Shifter Lever A	TW-1021	1
7-42	ML639810	Shifter Lever C, w/pin A	TY-1003	1
7-43	EP537895	Plunger Solenoid 1254THT	44-1-53	1
7-44	MH257477	Connecting Pin	RD-211	1
7-45	ZG533733	Shifter Spring B	TW-1039	1
7-46x	ZS349288	Screw, binding head 3x5, w/washer		2
7-47	MC551351	Counter M-470G	9-1-29	1
7-48	MB533068	Counter Belt B D91.8x1.2	TW-1019	1
7-49x	MZ533801	Reinforcement Angle	TW-1045	2
7-50x	ZS416687	Screw, binding head 4x8		8
7-51x	EZ624047	Cord Retainer	2-7-48	2
7-52x	MZ533812	Servo Shield	TW-1046	1
7-53x	EJ205986	Cramp Terminal 2-SD	32-1-8	2
7-54x	MZ229138	Wire Bundle Holder N-108	2-35-1	1
7-55	MZ643645	Panel Support C	TY-6019	1
7-56x	MZ643656	Panel Support D	TY-6019	1

When ordering parts, please describe Parts Number, Serial Number, and Model Number in detail

## 8. ILLUSTRATION OF POWER SUPPLY BLOCK

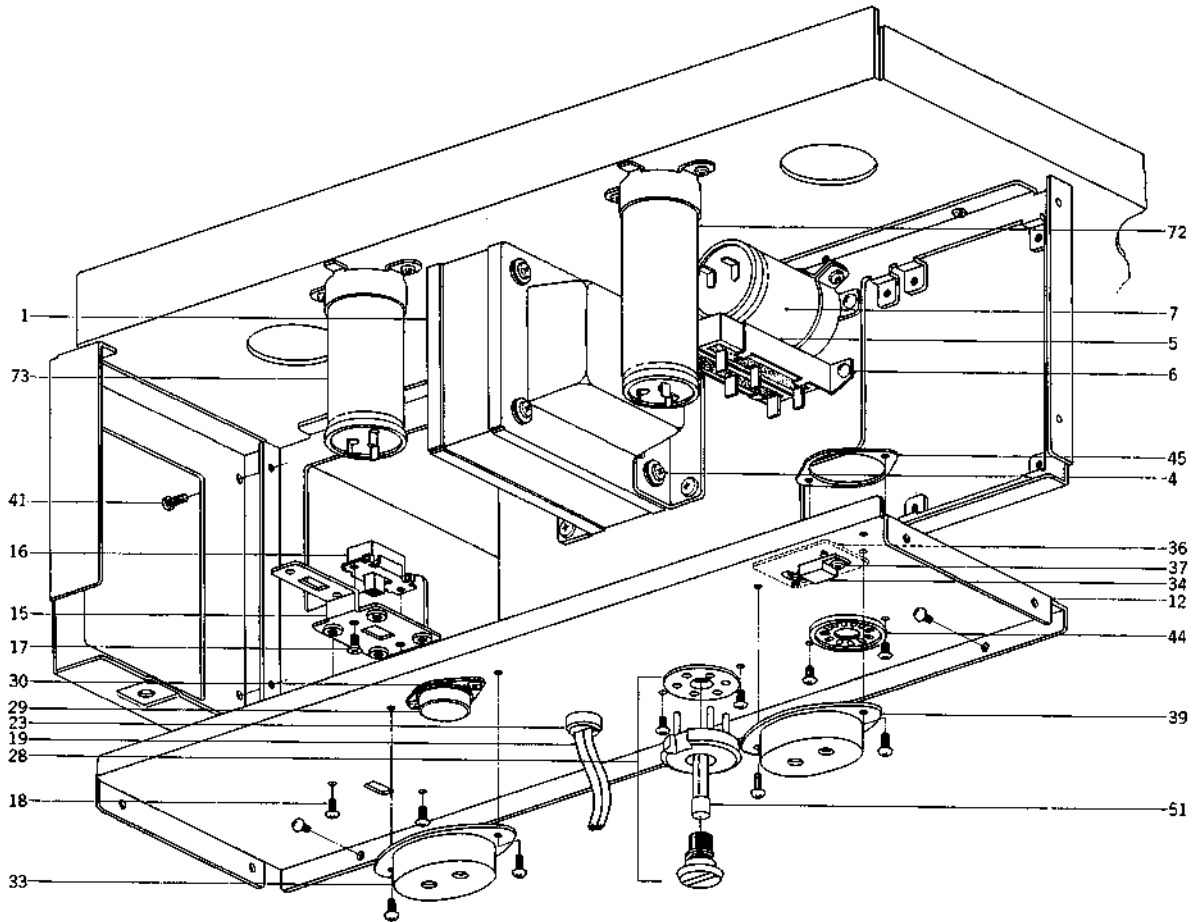

### 8) POWER SUPPLY BLOCK

Ref. No.	Parts No.	Description	Schematic No.	Q'ty	Ref. No.	Parts No.	Description	Schematic No.	Q'ty
8-1	BT641182	Power Trans. TYT-1	38-4-355	1	8-23	EZ382263	Strain Relief SR-4K-4	2-7-12	1
8-2x	BT647638	Power Trans. TYT-3 (CEE)	38-4-350	1	8-24x	ZW273881	Earth Lug M4 (CEE)		1
8-3x	BT647561	Power Trans. TYT-2 (CSA, JPN)	38-4-349	1	8-25x	ZW273892	Toothed Lock Washer M4 (CEE)		1
8-4	ZS434250	Screw, pan head 4x8, w/washer		4	8-26x	ZS417150	Screw, pan head 4x6 (CEE)		1
8-5	ER666270	Cement/R. (20+20)B(43+220+80)K	35-16-63	1	8-27x	ZW413188	Nut M4 (CEE)		1
8-6	ZS325495	Tapping Screw #2 3x6 (BR)		13	8-28x	EJ233370	Socket (Volt. Selector) S-18010	40-2-3	1
8-7	EC557190	Eelect./C. (Lug Type) 470μF 160WV	24-10-88	1	8-29	ET538007	Transistor 2SC792	45-1-139	1
8-8x	MZ643803	Connector Angle	TY-2001	1	8-30	ZS380046	Screw, pan head 3x10		2
8-9x	MZ643667	P.C Board Angle A	TY-2002	1	8-31x	ZW273745	Spring Washer M3		1
8-10x	ZW562476	Earth Lug M3		5	8-32x	ZW273756	Nut M3		3
8-11x	ZW273802	Toothed Lock Washer M3		3	8-33	EZ534025	Transistor Cover	TW-2017	1
8-12	SP694440	Rear Plate F-1	TW-2102	1	8-34	ET393557	Transistor 2SD234(R)(O)	45-1-81	1
8-13x	SP694912	Rear Plate H-1 (CEE, CSA)	TW-2102	1	8-35x	TA409836	Insulator Plate AC-221	45-1-90	1
8-14x	SP694901	Rear Plate G-1 (JPN)	TW-2102	1	8-36	EA534036	Transistor P.C Board	TW-2019	1
8-15	EZ397304	Frequency Change SW. Plate A	KD-2043	1	8-37	ZS421806	Screw, pan head 3x8		1
8-16	ES479485	Slide SW. S-1	25-3-66	1	8-38x	ZS422076	Screw, pan head 3x5		6
8-17	ZS327835	Screw, countersunk head 3x5		2	8-39	EZ534025	Transistor Cover	TW-2017	1
8-18	ZS201150	Screw, truss head 3x6 (Black)		8	8-40x	MZ533946	Mecha Side Plate A	TW-2013	1
8-19	EW374894	AC Cord CUL 3M	26-3-19	1	8-41	ZS413201	Screw, pan head 4x8		4
8-20x	EW516600	AC Cord (CEE) VM-0065	26-3-28	1	8-42x	EJ310871	Multi-jack (J-2) 18P 3250-018-001	31-4-11	1
8-21x	EW524845	AC Cord (J) 2.5M	26-3-31	1	8-43x	EJ364915	Multi-jack 10P PB01-10S-24E2G	31-4-15	1
8-22x	EW207742	AC Cord CUL (CSA)	26-3-45	1	8-44	EJ222748	Socket, sub magnale #311SG	31-1-39	1

When ordering parts, please describe Parts Number, Serial Number, and Model Number in detail

Ref. No.	Parts No.	Description	Schematic No.	Q'ty
8-45	MZ302400	Remote Control Socket Mt. Plate	RX-515	1
8-46x	EJ639134	9P Socket Housing 103-3-9R	31-1-140	1
8-47x	EJ639123	F Terminal 103-3-R	32-1-65	7
8-48x	ZS447840	Tapping Screw #2 3x8 (BR)		2
8-49x	EJ205986	Cramp Terminal 2-SD	32-1-8	8
8-50x	EJ205975	Cramp Terminal 1-SD (CEE, CSA, JPN)	32-1-7	9
8-51	EF562691	Fuse 2.5A 250V	39-1-50	1
8-52x	EF601953	Fuse (SEMKO T Type) 800MAT (CEE)	39-1-53	4
8-53x	EF601964	Fuse (SEMKO T Type) 1.6AT (CEE)	39-1-53	2
8-54x	EF550618	Fuse ULMF61M 250V 1.5A (CSA)	39-1-45	4
8-55x	EF662534	Fuse ULMF61M 250V 2.5A (CSA)	39-1-45	3
8-56x	EF563692	Fuse 1.5A 250V (JPN)	39-1-50	4
8-57x	EF562691	Fuse 2.5A 250V (JPN)	39-1-50	3
8-58x	EF623103	Fuse (SEMKO T Type) 1AT (CEE)	39-1-53	1
8-59x	EA645131	Fuse P.C Board TY-2 (CEE)	40-1-67	1
8-60x	EA647651	Fuse P.C Board TY-1 (CSA, JPN)	40-1-66	1
8-61x	EA614632	Fuse P.C Board MY-2 (CEE)	MY-2046	1
8-62x	EA615093	Fuse P.C Board MY-1 (CSA, JPN)	MY-2045	1
8-63x	EZ614586	Fuse Table MY (CEE, CSA, JPN)	MY-2043	1
8-64x	EA642442	Fuse P.C Board TY (CEE)	TY-2017	1
8-65x	EA614621	Fuse P.C Board EG (CSA, JPN)	EG-5075	1
8-66x	EJ592503	Fuse Clip, P.C Board H0426 (CEE)	40-1-37	8
8-67x	EJ514822	Fuse Holder, P.C Board S-N5051 (CSA, JPN)	40-1-28	8
8-68x	EZ614586	Fuse Table MY (CEE, CSA, JPN)	MY-2043	1
8-69x	EZ624047	Cord Retainer (CEE, CSA, JPN)	2-7-48	4
8-70x	ED666314	Thermister PTH 63AR6R8M2E491 (CEE, CSA, JPN)	45-14-4	1
8-71x	EJ254970	Lug Plate KP1L1 (CEE, CSA, JPN)	33-3-3	1
8-72	EC641136	MP/C. (Lug Type UNI/D.) 4+4μF 250WV AC	24-9-103	1
8-73	EC583018	MP/C. (Lug Type UNI/D.) 4+1.5μF 150WV	24-9-71	1

## 9. P.C BOARDS

### (1) SERVO P.C BOARD (TW-1049) BLOCK

Symbol No.	Parts No.	Description	Q'ty
(1)-1	BA552407	Servo P.C Board Comp. (TW-1049)	1
(1)-TR1	ET334383	Transistor 2SC971	1
(1)-TR2,3	ET379462	Transistor 2SC711(D)(E)	2
(1)-TR4	ET538154	Transistor 2SA564(Q)(R)	1
(1)-TR5,6	ET379462	Transistor 2SC711(D)(E)	2
(1)-TR7	ET664626	Transistor 2SC711(D2)	1
(1)-TR8	ET379462	Transistor 2SC711 (D)(E)	1
(1)-TR9	ET538154	Transistor 2SA564(Q)(R)	1
(1)-TR10,11	ET538143	Transistor 2SC711(E2-Special)	2
(1)-TR12	ET379462	Transistor 2SC711(D)(E)	1
(1)-TR13	ET538154	Transistor 2SA564(Q)(R)	1
(1)-TR14	ET399881	Transistor 2SC711(F)	1
(1)-TR15	ET379462	Transistor 2SC711(D)(E)	1
(1)-TR16,17	ET398711	Transistor 2SC945L(Q)(R)	2
(1)-D1	ED350471	Zener Diode RD-7A(N)	1
(1)-D2,3,4	ED224526	Silicon Diode 10D1	3
(1)-D5	ED538042	Zener Diode RD-7A(L)	1
(1)-D6	ED560913	Silicon Diode 1S2473 VE	1
(1)-D7	ED538165	Silicon Diode 10DC-2(REDF)	1
(1)-D8	ED538176	Silicon Diode 10DC-2 (BLACK)	1
(1)-RL1	EP616500	Relay LC1-C-JT DC24V	1
(1)-CR1,2	ER376435	Spark Quencher U/L 0.1μF+120 ohms 250 WV	2
(1)-VR1	EV484863	Semi-fixed/Vol. (Metalized Film) V10K8-4-2 1 kB	1
(1)-VR2	EV538187	Semi-fixed/Vol. V10K4H-4-2 5 kB	1
(1)-VR3	EV538198	Semi-fixed/Vol. V10K4H-4-2 10 kB	1
(1)-VR4	EV538200	Semi-fixed/Vol. V10K4H-4-2 30 kB	1
(1)-TH1	ED557201	Thermister 31D26 AK	1
(1)-R57	ER427241	Metal Oxide Film/R. 2W 330 ohms (K)	1
(1)-C10	EC406800	Capacitor, Vertical Type Styrol 5600PF(G) 50WV (Tub. Type)	1
(1)-C13	EC538244	Solid Aluminum 0.47μF(M) 10WV	1
(1)-C15	EC538244	Solid Aluminum 0.47μF(M) 10WV	1
(1)-C20	EC557155	Solid Aluminum 1μF(M) 10WV	1
(1)-C21	EC601132	NP Elect 0.47μF(M) 50WV	1

### (2) SYS. CON P.C BOARD (TY-1006) BLOCK

Symbol No.	Parts No.	Description	Q'ty
(2)-1	BA662848	Sys. Con P.C Board Comp. (TY-1006)	1
(2)-TR1to6	ET639437	Transistor 2SC945L(Q)(P)	6
(2)-TR7	ET511920	Transistor 2SC1247A(B)(V)	1
(2)-TR8to14	ET639437	Transistor 2SC945L(Q)(P)	7
(2)-TR15	ET511920	Transistor 2SC1247A(B)(V)	1
(2)-D1to13	ED560913	Silicon Diode 1S2474VE	13
(2)-D14to28	ED624903	Silicon Diode 1S2473	15

**(3) POWER SUPPLY P.C BOARD (TY-2003) BLOCK**

Symbol No.	Parts No.	Description	Q'ty
(3)-1	BA662826	Power Supply P.C Board Comp. (TY-2003)	1
(3)-TR1	ET418871	Transistor 2SC1014(C)(D)	1
(3)-TR2	ET511920	Transistor 2SC1247A(B)(V)	1
(3)-D1	ED538042	Zener Diode RD-7A(L)	1
(3)-D2to5	ED224526	Silicon Diode 10D1	4
(3)-VR1	EV554670	Semi-fixed/Vol. V10K8-1-5 1 kB	1

**(4) RELAY P.C BOARD (TY-2004) BLOCK**

Symbol No.	Parts No.	Description	Q'ty
(4)-1	BA662837	Relay P.C Board Comp. (TY-2004)	1
(4)-D1	ED224550	Silicon Diode 10D4	1
(4)-D2to5	ED624903	Silicon Diode 1S2473	4
(4)-D6,7	ED224550	Silicon Diode 10D4	2
(4)-D8	ED624903	Silicon Diode 1S2473	1
(4)-RL1to3	EP638763	Relay MY4-O-US DC24V	3
(4)-RL4	EP616500	Relay LC1-C-JT DC24V	1
(4)-CR1to5	ER376435	Spark Quencher U/L 0.1 $\mu$ +120 ohms 250WV	5
(4)-R1	ERS63253	Cement/R. (Wire-wound Type) 3W 2.2 ohms(K)	1
(4)-R4	ER538121	Cement/R. (Wire-wound Type) 5W 68 ohms (K)	1
(4)-C3,4	EC350987	MP/C. 0.47 $\mu$ F(M) 250V DC	2

**(5) PB P.C BOARD (TY-5007) BLOCK**

Symbol No.	Parts No.	Description	Q'ty
(5)-1	BA662938	PB P.C Board Comp. (TY-5007)	1
(5)-TR1	ET352146	Transistor 2SC458LG(D)	2
(5)-TR2	ET639538	Transistor 2SA640(E)	2
(5)-TR3,4	ET453486	Transistor 2SC711(E)(F)	4
(5)-TR5	ET352146	Transistor 2SC458LG(D)	2
(5)-TR6	ET639538	Transistor 2SA640(E)	2
(5)-TR7to11	ET639437	Transistor 2SC945L(Q)(P)	8
(5)-D1	ED219464	Germanium Diode 1N34A	2
(5)-T1	BT517274	Headphone Trans. N16-535S	2
(5)-L1	EO496361	Inductor 6070GE 23MH(J)	2
(5)-VR1	EV464220	Semi-fixed/Vol. V8K4-1 50 kB	2
(5)-VR2	EV622967	2-axial 2-throw/Vol. (FR.) V24L5DGPHN 50 kAx2	1
(5)-VR3	EV464196	Semi-fixed/Vol. V8K4-1 2 kB	2

**(6) REC P.C BOARD (TY-5008) BLOCK**

Symbol No.	Parts No.	Description	Q'ty
(6)-1	BA662927	Rec P.C Board Comp. (TY-5008)	1
(6)-TR1to5	ET391768	Transistor 2SC458LG(C)(D)	10
(6)-TR6to8	ET639437	Transistor 2SC945L(Q)(P)	4
(6)-D1	ED560913	Silicon Diode 1S2473VE	1
(6)-VR1	EV622078	2-axial 2-throw/Vol. V24L5DPHN 50 kAx2	210
(6)-VR2,3	EV522797	Semi-fixed/Vol. V8K4-1 20kB	4
(6)-RL1	EP621808	Relay MTS-2	1
(6)-T1	EO383365	OSC Coil OT-204	1
(6)-L1	EO458932	Ferri Inductor FL7H 2.2MH(J)	2
(6)-R40	ER524788	Metal Oxide Film/R. 2W 180 ohms (K)	1
(6)-C23	EC405898	Styrol/C. (Vert. Type) 470PF(J) 50WV	2
(6)-C25	EC343372	Plastic Film/C. 1800PF(J) 500WV	1
(6)-C29	EC558202	Trimmer/C. TM-80A 80PF	2

**(7) TS P.C BOARD (TY-5010) BLOCK**

Symbol No.	Parts No.	Description	Q'ty
(7)-1	BA662951	TS P.C Board Comp. (TY-5010)	1
(7)-SW1	ES619277	Rotary SW. SRZ-VO63	1

**(8) EQ P.C BOARD (TY-5009) BLOCK**

Symbol No.	Parts No.	Description	Q'ty
(8)-1	BA662940	EQ P.C Board Comp. (TY-5009)	1
(8)-D1to3	ED560913	Silicon Diode 1S2473 VE	3
(8)-SW1	ES641125	Rotary SW. SRE-4143	1
(8)-L1	EO369178	Ferri Inductor FL7H 1.5 MH(J)	1
(8)-L2	EO380564	Ferri Inductor FL7H 1.8MH(J)	1
(8)-L3	EO369178	Ferri Inductor FL7H 1.5 MH(J)	1
(8)-L4	EO380564	Ferri Inductor FL7H 1.8MH(J)	1

**(9) STOP DETECTION P.C BOARD  
(TY-1005) BLOCK**

Symbol No.	Parts No.	Description	Q'ty
(9)-1	BA662905	Stop Detection P.C Board Comp. (TY-1005)	1
(9)-IC1	EI620640	IC DN-831	1
(9)-TR1,2	ET639437	Transistor 2SC945L(Q)(P)	2
(9)-D1	ED560913	Silicon Diode 1S2473 VE	1

## 10. ILLUSTRATION OF AMPLIFIER ASSEMBLY BLOCK

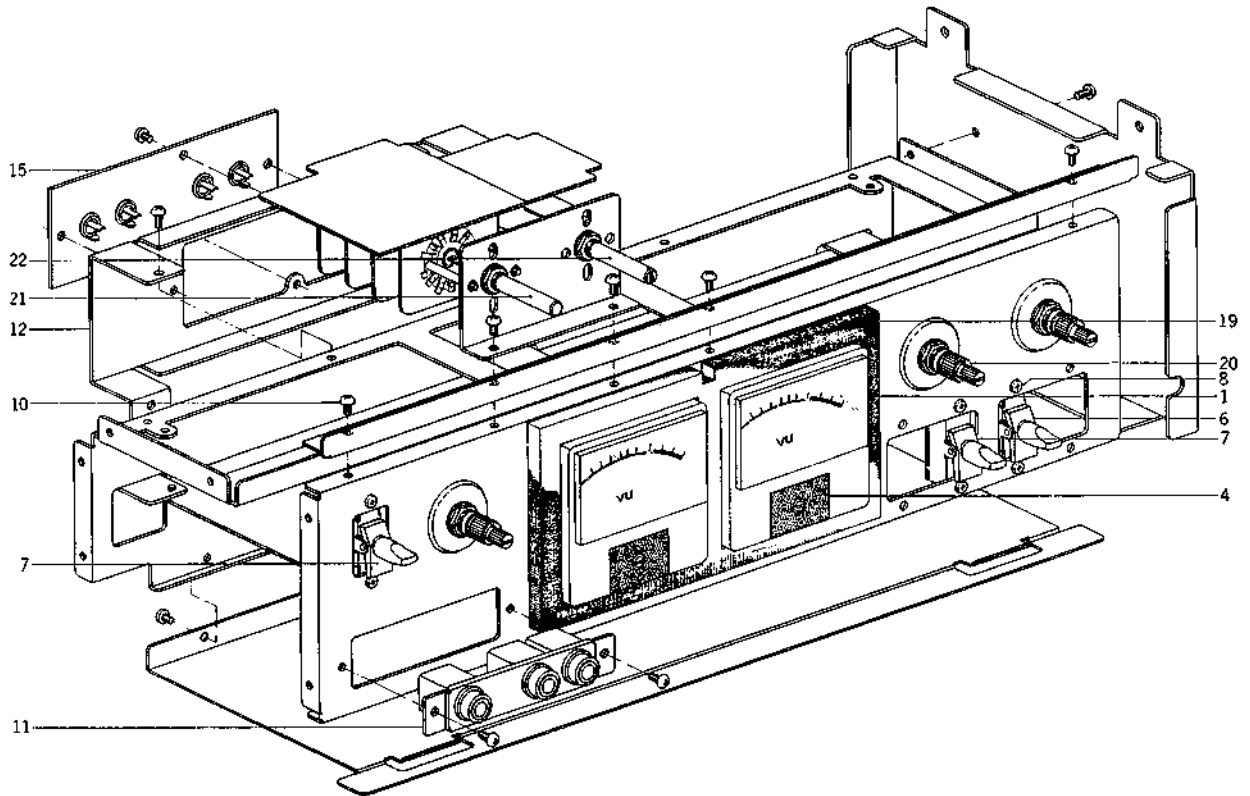

### 10) AMPLIFIER ASSEMBLY BLOCK

Ref. No.	Parts No.	Description	Schematic No.	Q'ty
10-1	EM573748	VU Meter KL-250B-28C (Yellow)	46-1-86	2
10-2x	ZG290878	VU Meter Spring	DX-504	4
10-3x	ZW273756	Nut M3		4
10-4	SE529457	Meter Mask	ND-5043	2
10-5x	ZW465715	Washer (SPC) D3.2x6x0.5t		4
10-6	ES641226	Lever SW. S-J6308	25-12-22	1
10-7	ES641215	Lever SW. S-J6398	25-12-23	2
10-8	ZS422076	Screw, pan head 3x5		6
10-9x	ZW562476	Earth Lug M3		2
10-10	ZS325495	Tapping Screw #2 3x6(BR)		14
10-11	EJ641204	Jack, 3-throw	31-2-65	1
10-12	EZ643757	Jack Table	TY-5006	1
10-13x	EJ557245	Nylon Clip SN-3A	2-7-29	1
10-14x	ZW273802	Toothed Lock Washer M3		5
10-15	EJ662545	Jack Plate TY	31-5-124	1
10-16x	ZS447761	Tapping Screw #2 3x6(BR) (Black)		4
10-17x	EJ255082	Lug Plate VBL2	33-4-10	1
10-18x	EO482905	Ferri Inductor FL9H 220μH(J)	23-1-4	1
10-19	SZ631091	Meter Cushion B	MY-6203	1
10-20	EV622078	2-axial 2-throw/V.o. V24LSDPHN 50kAx2	36-3-60	2
10-21	ES641125	Rotary SW. SRE-4143	25-4-79	1
10-22	ES619277	Rotary SW. SRZ-V063	25-6-78	1

When ordering parts, Please describe Parts Number, Serial Number, and Model Number in detail.

## 11. PHOTO OF FINAL ASSEMBLY BLOCK

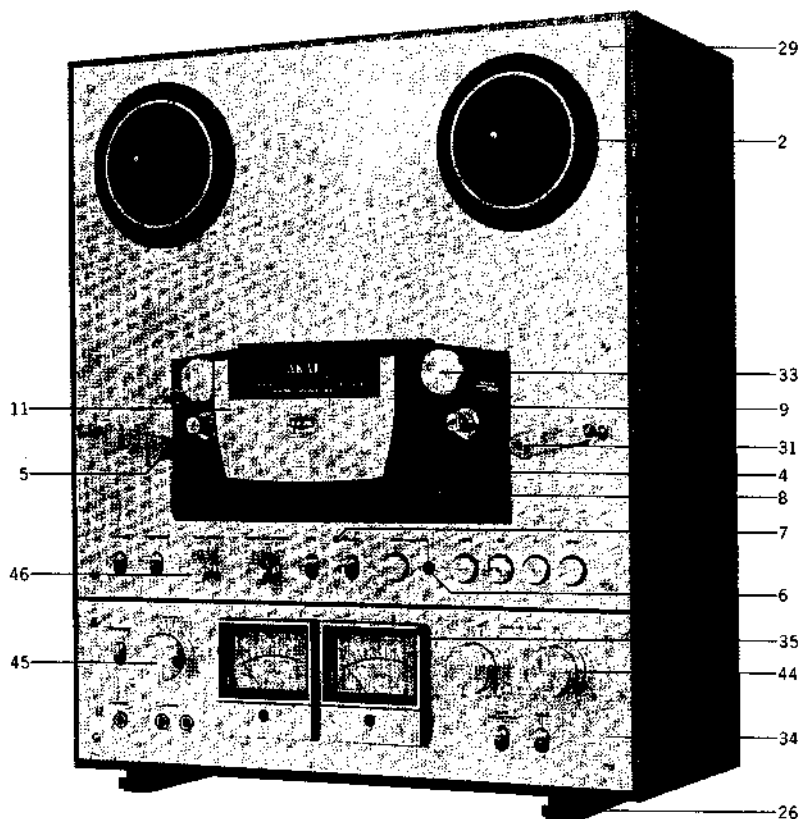

### 11) FINAL ASSEMBLY BLOCK

Ref. No.	Parts No.	Description	Schematic No.	Q'ty
<b>MECHA PANEL BLOCK</b>				
11-1x	BZ662681	Mecha Panel Block Comp.	TY	1
11-2	SE626940	Reel Table Escutcheon	MY-6004	2
11-3x	ZW575730	Speed Nut (P Type) 3	6-3-6	14
11-4	SC643735	Head Cover Base	TY-6003	1
11-5	SE534216	Tension Arm Escutcheon	TW-6004	2
11-6	SE612055	Lamp Lens A	CH-6314	1
11-7	SE639707	Lamp Lens B-3	NE-6005	1
11-8	SE534240	Counter Lens	TW-6007	1
11-9	SC643724	Head Cover	TY-6004	1
11-10x	SZ534543	Cushion Rubber C	TW-6039	2
11-11	SM643691	Head Cover Name Palte	TY-6005	1
11-12x	SZ534317	Hinge Rod, w/angle A,B	TW-6012	1
11-13x	MH534328	Hinge Pin	TW-6013	2
11-14x	MV269965	Steel Ball D4		1
11-15x	ZG249107	Ball Retaining Spring	RD-632	1
11-16x	ZW499893	Set Screw, hexagon socket 5x4 flat point		1
11-17x	SZ534306	Hinge Angle C	TW-6011	1
11-18x	ZS355522	Screw, pan head 3x6		4
11-19x	ZW555693	Washer (SPC) D3.2x8x0.5t		2
<b>CASE BLOCK</b>				
11-20	BC662670	Case Block Comp.	TY	1
11-21x	SE382217	Fan Grill	RD-A402	1
11-22x	ZS324448	Tapping Screw #1 3x10 (Truss) (Black)		3
11-23x	SE535241	Ventilator A	TW-4002	1
11-24x	SE535252	Ventilator Suppport	TW-4004	3
11-25x	ZS553994	Tapping Screw #1 3x8 (Round)		6
11-26	SA640934	Square Foot, w/rubber	TE-6020	2

Ref. No.	Parts No.	Description	Schematic No.	Q'ty
11-27x	ZS200610	Tapping Screw #1 4x12 (Truss)		4
11-28x	SZ480712	Dust Cover Pin	LE-6024	2
<b>ASSEMBLY BLOCK</b>				
11-29	ZS613901	Panel Screw	CW-6031	10
11-30x	ZS608501	Screw, pan head 3x12		2
11-31	ZW535094	Decorative Washer	TW-2077	2
11-32x	ZS203084	Screw, oval countersunk head 3x8		2
11-33	SK632610	Pinch Roller Cap B	TW-6019	2
11-34	SP643702	Amp Panel A	TY-6005	1
11-35	SE631102	VU Escutcheon	MY-6205	2
11-36x	ZS575392	Screw, pan head 2.6x8		8
11-37x	ZW318014	Washer (BSP) D2.6x4.5x0.4t		8
11-38x	SA428714	LM Rubber Foot, w/screw	LM-404	4
11-39x	ZW419646	Washer (SPC) D4.5x9.8x0.5t		4
11-40x	ZS448288	Tapping Screw #1 4x35 (Truss)		4
11-41x	ZS488327	Tapping Screw #1 4x25 (Truss), w/washer		2
11-42x	ZS608670	Screw, pan head 4x30		4
11-43x	ZW603123	Washer (SPC)D4.5x13x1t		4
11-44	SK639977	Double Knob (Lower)	TY-6009	3
11-45	SK639988	Double Knob (Upper)	TY-6008	3
11-46	SK643612	Selector Knob Comp.	TY-6014	2

When ordering parts, Please describe Parts Number, Serial Number, and Model Number in detail.

## 12. LIST OF INTERCHANGEABLE SEMICONDUCTORS

As far as service in concerned, in case the original parts cannot be obtained, the interchangeable parts listed below can be substituted.

Original Parts			Interchangeable Parts	
Description	Parts No.	Utilizing P.C Board	Description	Parts No.
2SA564 (Q) (R)	ET538154	TW1049	2SA733 (Q) (R)	ET557965
2SA640 (E)	ET639538	TY-5007	2SA733 (P) 2SA628 (E)	ET539133 ET516554
2SC458LG (C) (D) 2SC458LG(D)	ET391768 ET352146	TY-5007 TY-5008	2SC693U (F) 2SC1312 (G) (H)	ET315472 ET517263
2SC711 (E) (F) 2SC711 (D) (E) 2SC711(F)	ET453486 ET379462 ET399881	TY-5007 TW-1049	2SC945L (Q) (R) 2SC1647 (R) (S) (E)	ET398711 ET623733
2SC711 (E2) Special	ET538143	TW-1049		
2SC792	ET538007			
2SC945L (P) (Q)	ET639437	TY-5007 TY-5008 TY-1005 TY-1006	2SC536 (F) (G) (H) 2SC1647 (S) (E)	ET632215 ET592424
2SC971	ET334383	TW-1049		
2SC1014 (C) (D)	ET418871	TY-2003		
2SC1247A (B) (V)	ET511920	TY-1006 TY-2003	2SC1175 (E) (F) 2SC1211 (E) (F)	ET622080 ET666393
2SD234 (R) (O)	ET393557		2SD313 (E) (F) (D)	ET522911
1N34A	ED219464	TY-1006 TY-2004	1S188AM 1N60	ED562386 ED428264
1S2473	ED624903	TY-1006 TY-2004	1S1588	ED557447
1S2473VE	ED560913	TY-5008 TY-5009 TY-1005 TY-1006 TW-1049	WG599 WG713 1S1588	ED514721 ED515790 ED557447
1OD1	ED224526	TY-2003 TW-1049	1N4002	ED511907
1OD4	ED224550		1N4004	ED570273

# INDEX

Parts No.	Ref. No. & Symbol No.	Parts No.	Ref. No. & Symbol No.	Parts No.	Ref. No. & Symbol No.	Parts No.	Ref. No. & Symbol No.	Parts No.	Ref. No. & Symbol No.
BA552407	(1)-1	EF662534	8-55x	ET538154	(1)-TR13	MR534690	3-18	SP694912	8-13x
BA662826	(3)-1	EI620640	(9)-1C1	ET639437	(2)-TR1to6	MS342000	3-8	SZ480712	11-28x
BA662837	(4)-1	EJ205975	8-50x	ET639437	(2)-TR8to14	MS532956	4-32	SZ534306	11-17x
BA662848	(2)-1	EJ205986	7-53x	ET639437	(5)-TR7to11	MS532956	7-7	SZ534317	11-12x
BA662905	(9)-1	EJ205986	8-49x	ET639437	(6)-TR6to8	MS532980	7-12	SZ534543	11-10x
BA662927	(6)-1	EJ222748	8-44	ET639437	(9)-TR1,2	MS533147	5-20	SZ631091	10-19
BA662938	(5)-1	EJ233370	8-28	ET639538	(5)-TR2	MS533867	4-19	SZ639887	6-11
BA662940	(8)-1	EJ254970	8-71x	ET639538	(5)-TR6	MS534723	4-9	SZ639900	6-20
BA662951	(7)-1	EJ255082	10-17x	ET664626	(1)-TR7	MS534936	5-8	SZ639911	6-21
BC662670	11-20	EJ255115	6-24	EV464196	(5)-VR3	MS535173	4-4	TA409836	8-35x
BF552330	4-7x	EJ310871	8-42x	EV464220	(5)-VR1	MT314987	7-28	TC494267	6-30
BH662771	1-1x	EJ315101	1-30	EV383863	(1)-VR1	MT436860	3-17	VT360090	4-16x
BL662883	5-1x	EJ364915	8-43x	EV522797	(6)-VR2,3	MT534666	3-6	ZG243257	4-24
BL662894	5-2x	EJ514822	8-67x	EV538187	(1)-VR2	MT534677	3-7	ZG249107	11-15x
BM662736	2-1	EJ557245	10-13x	EV538187	(1)-VR3	MT534688	3-11	ZG290878	10-2x
BM662747	3-1	EJ592503	8-66x	EV538200	(1)-VR4	MT632621	3-12	ZG364656	1-25
BR552328	3-4x	EJ639123	8-47x	EV554670	(3)-VR1	MT632654	3-13	ZG382757	1-20
BR662861	3-5x	EJ639134	8-46x	EV622078	(6)-VR1	MV269965	4-44	ZG382757	6-4
BT517274	(5)-T1	EJ641204	10-11	EV622078	10-20	MV269965	11-14x	ZG466312	1-8
BT611182	8-1	EJ662545	10-15	EV622967	(5)-VR2	MZ229138	7-54x	ZG533700	4-34x
BT647561	8-3x	EL443520	6-26	EW207742	8-22x	MZ237418	7-16	ZG533711	4-35
BT647638	8-2x	EL666292	6-19	EW374894	8-19	MZ302400	8-45	ZG533733	7-45
BZ552385	4-1x	EM573748	10-1	EW516600	8-20x	MZ314998	7-29	ZG535105	5-14
BZ556694	2-7	EO369178	(8)-L1	EW524845	8-21x	MZ450720	2-9	ZG535162	4-3
BZ662681	11-1x	EO369178	(8)-L3	EZ382263	8-23	MZ533035	7-13	ZG540090	7-31
BZ662850	6-1x	EO380564	(8)-L2	EZ397304	8-15	MZ533665	7-25	ZG540617	3-9
BZ662872	5-18x	EO380564	(8)-L4	EZ428117	6-25	MZ533687	7-34	ZS200610	11-27x
BZ681906	6-2x	EO383365	(6)-T1	EZ534025	8-33	MZ533801	7-49x	ZS201150	8-18
EA463206	1-11x	EO458932	(6)-L1	EZ534025	8-39	MZ533812	7-52x	ZS201475	1-17
EA466547	1-12x	EO482905	10-18x	EZ586326	6-18	MZ533880	4-21	ZS201778	1-32
EA534036	8-36	EO496361	(5)-L1	EZ614586	8-63x	MZ533946	8-40x	ZS203084	4-6
EA540573	1-13x	EP537895	7-43	EZ614586	8-68x	MZ534701	4-10	ZS203084	5-22
EA614621	8-65x	EP537906	7-17	EZ624047	7-51x	MZ534745	4-11	ZS203084	11-32x
EA614632	8-61x	EP538457	4-27	EZ624047	8-69x	MZ534903	5-3	ZS243516	4-36
EA615093	8-62x	EP616500	(1)-RL1	EZ643757	10-12	MZ534914	5-4	ZS323728	4-41
EA642442	8-64x	EP616500	(4)-RL4	HA533597	1-23	MZ535116	4-2	ZS323728	7-23x
EA645131	8-59x	EP621808	(6)-RL1	HA533608	1-16	MZ543025	7-26	ZS324448	11-22x
EA647651	8-60x	EP638763	(4)-RL1to3	HE563220	1-15	MZ549720	4-13	ZS325495	6-12
EC343372	(6)-C25	ER376435	(1)-CR1,2	HP552194	1-26	MZ585900	4-54	ZS325495	8-6
EC350987	(4)-C3,4	ER376435	(4)-CR1to5	HR384513	1-22	MZ639898	6-15	ZS325495	10-10
EC405898	(6)-C23	ER427241	(1)-R57	HZ532697	1-5	MZ639922	3-22	SZ327835	8-17
EC406800	(1)-C10	ER430222	6-29x	HZ532708	1-3	MZ639955	5-15	SZ349288	7-46x
EC538244	(1)-C13	ER524788	(6)-R40	HZ532710	1-7	MZ641193	3-21	SZ355522	11-18x
EC583244	(1)-C15	ER538121	(4)-R4	HZ532732	1-18	MZ643645	7-55	SZ379405	4-29x
EC551160	6-27x	ER554556	6-28	HZ532765	1-28	MZ643656	7-56x	SZ379405	5-13
EC557155	(1)-C20	ER563253	(4)-R1	HZ532776	1-27	MZ643667	8-9x	SZ379405	7-18x
EC557190	8-7	ER666270	8-5	HZ643623	1-14	MZ643678	6-3	SZ380046	8-30
EC558202	(6)-C29	ES205110	6-23x	HZ643634	1-2	MZ643680	6-13	SZ384131	2-2
EC583018	8-73	ES250075	6-16	MB533057	7-37	MZ643803	8-8x	SZ396000	1-29
EC601132	(1)-C21	ES479485	8-16	MB533068	7-48	MZ692875	4-45	SZ413201	1-4
EC641136	8-72	ES562465	7-14	MB533070	4-42	MZ802980	4-25	ZS413201	4-43x
ED219464	(5)-D1	ES573478	5-5	MC551351	7-47	MZ810191	5-7	ZS413201	8-41
ED224526	(1)-D2,3,4	ES619277	(7)-SW1	MH257477	7-44	MZ810191	7-40	ZS413212	5-23
ED224526	(3)-D2to5	ES619277	10-22	MH529233	1-9	SA428714	11-38x	ZS413234	3-3x
ED224550	(4)-D1	ES641125	(8)-SW1	MH532462	2-3	SA640934	11-26	ZS416687	4-47x
ED224550	(4)-D6,7	ES641125	10-21	MH532912	7-1	SB639832	6-6	ZS416687	7-10x
ED224550	4-28x	ES641215	10-7	MH532923	7-3	SB639843	6-7	ZS416687	7-50x
ED224550	7-19x	ES641226	10-6	MH532934	7-4	SB639854	6-8	ZS417148	5-6
ED350471	(1)-D1	ES647458	6-22	MH532945	7-6	SB639865	6-9	ZS417150	8-26x
ED538042	(1)-D5	ET334383	(1)-TR1	MH532978	7-9	SC643724	11-9	ZS419670	6-5
ED538042	(3)-D1	ET352146	(5)-TR1	MH533913	4-30	SC643735	11-4	ZS419670	6-17
ED538165	(1)-D7	ET352146	(5)-TR5	MH533913	7-21	SE382217	11-21x	ZS421806	8-37
ED538176	(1)-D8	ET379462	(1)-TR2,3	MH534328	11-13x	SE529457	10-4	ZS422076	6-14
ED557201	(1)-TH1	ET379462	(1)-TR5,6	ML534734	4-8	SE534216	11-5	ZS422076	8-38x
ED560913	(1)-D6	ET379462	(1)-TR8	ML533081	7-41	SE534240	11-8	ZS422076	10-8
ED560913	(2)-D1to13	ET379462	(1)-TR12	ML533632	7-27	SE535241	11-23x	ZS424056	2-4
ED560913	(6)-D1	ET379462	(1)-TR15	ML533643	7-33	SE535252	11-24x	ZS425103	3-16
ED560913	(8)-D1to3	ET391768	(6)-TR1to5	ML533654	7-20	SE612055	11-6	ZS425981	3-15x
ED560913	(9)-D1	ET393557	8-34	ML533845	4-17x	SE626940	11-2	ZS433315	3-19
ED624903	(2)-D14to28	ET398711	(1)-TR16,17	ML533856	4-18	SE631102	11-35	ZS434250	8-4
ED624903	(4)-D2to5	ET399881	(1)-TR14	ML533878	4-20	SE639707	11-7	ZS447761	10-16x
ED624903	(4)-D8	ET418871	(3)-TR1	ML534960	5-10	SK632610	4-40	ZS447840	8-48x
ED666314	8-70x	ET453486	(5)-TR3,4	ML534971	5-11	SK632610	11-33	ZS448288	11-40x
EF550618	8-54x	ET511920	(2)-TR7	ML535037	5-19	SK639977	11-44	ZS459033	2-6
EF562691	8-51	ET511920	(2)-TR15	ML639797	7-39	SK639988	11-45	ZS483502	7-15
EF562691	8-57x	ET511920	(3)-TR2	ML639808	7-38	SK643612	11-46	ZS488327	11-41x
EF563692	8-56x	ET538007	8-29	ML639810	7-42	SM643691	11-11	ZS516655	3-20
EF601953	8-52x	ET538143	(1)-TR10,11	MP676888	4-37	SP643702	11-34	ZS533766	4-39
EF601964	8-53x	ET538154	(1)-TR4	MR532440	2-5	SP694440	8-12	ZS537974	2-8
EF623103	8-58x	ET538154	(1)-TR9	MR533002	7-36	SP694901	8-14x	ZS553994	11-25x



# INDEX

Parts No.	Ref. No. & Symbol No.	Parts No.	Ref. No. & Symbol No.	Parts No.	Ref. No. & Symbol No.	Parts No.	Ref. No. & Symbol No.	Parts No.	Ref. No. & Symbol No.
ZS575392	11-36x								
ZS608477	1-19								
ZS608501	1-21								
ZS608501	11-30x								
ZS608670	11-42x								
ZS613901	11-29								
ZS687126	4-15x								
ZW259773	7-35								
ZW260076	4-38								
ZW260245	4-12								
ZW270088	3-10								
ZW270088	4-31								
ZW270088	5-17								
ZW270088	7-22								
ZW270123	2-10x								
ZW273745	8-31x								
ZW273756	1-6								
ZW273756	8-32x								
ZW273756	10-3x								
ZW273802	8-11x								
ZW273802	10-14x								
ZW273881	8-24x								
ZW273892	8-25x								
ZW273914	1-10								
ZW273914	7-11x								
ZW290250	2-11x								
ZW290283	7-30								
ZW318014	11-37x								
ZW330412	4-48x								
ZW330423	4-49x								
ZW330434	4-50x								
ZW330445	4-51x								
ZW334258	3-2x								
ZW382162	7-32x								
ZW413188	7-5x								
ZW413188	8-27x								
ZW413256	1-24								
ZW413278	4-33								
ZW413278	7-8x								
ZW416698	4-26								
ZW319646	11-39x								
ZW425002	5-12								
ZW425002	6-10								
ZW462205	4-46								
ZW465715	10-5x								
ZW499893	11-16x								
ZW516993	7-2x								
ZW533891	4-22								
ZW533902	4-23								
ZW534982	5-9								
ZW535094	5-21								
ZW535094	11-31								
ZW535217	4-5								
ZW550642	5-16								
ZW555693	11-19x								
ZW560215	4-52x								
ZW560226	4-53x								
ZW561486	7-24								
ZW562476	3-14x								
ZW562476	8-10x								
ZW562476	10-9x								
ZW562757	1-31								
ZW564276	4-14x								
ZW575730	11-3x								
ZW603123	11-43x								

---

SECTION 3

**SCHEMATIC DIAGRAM**

GX-650D

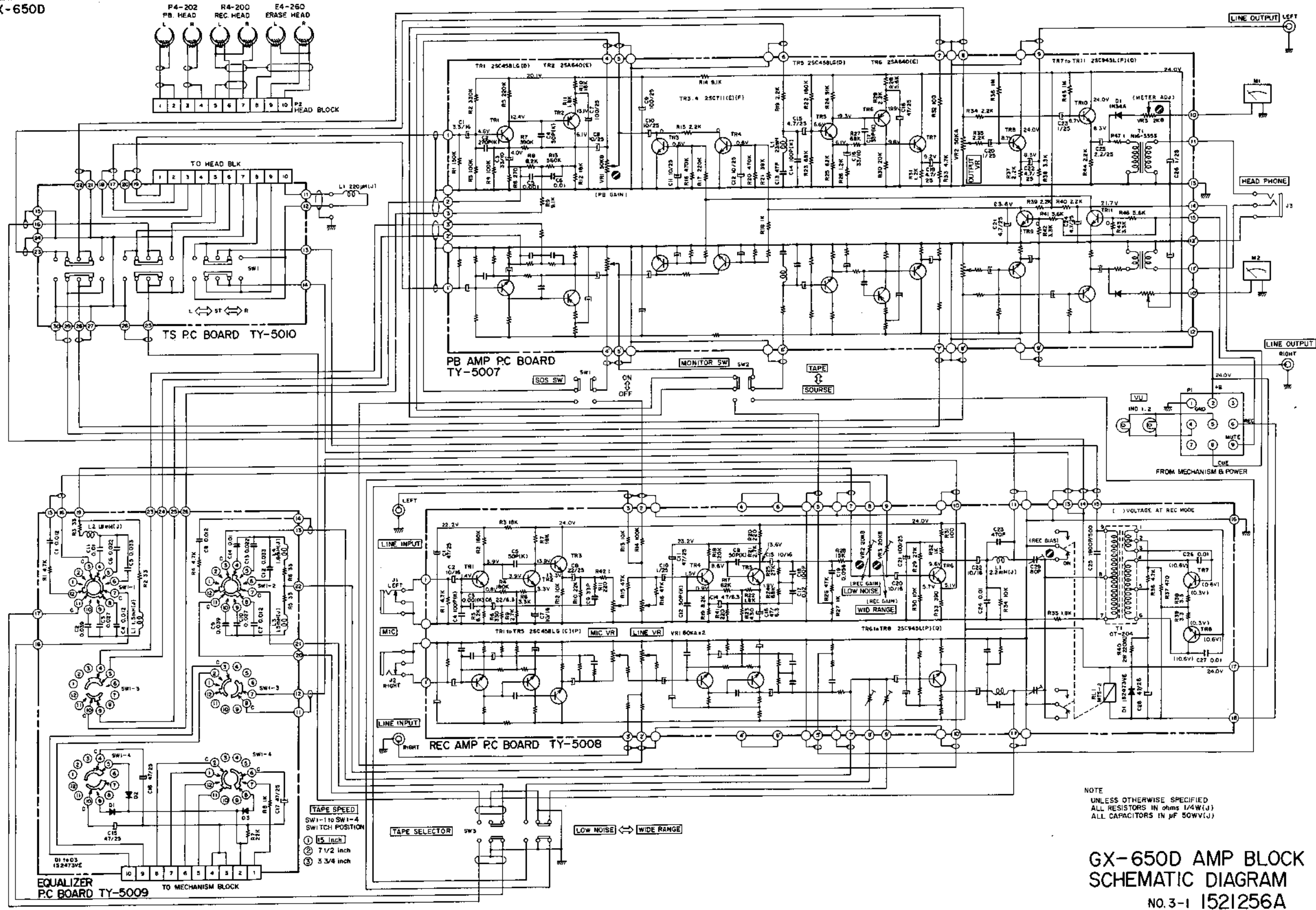

**GX-650D AMP BLOCK  
SCHEMATIC DIAGRAM**  
NO. 3-1 1521256A

GX-650D

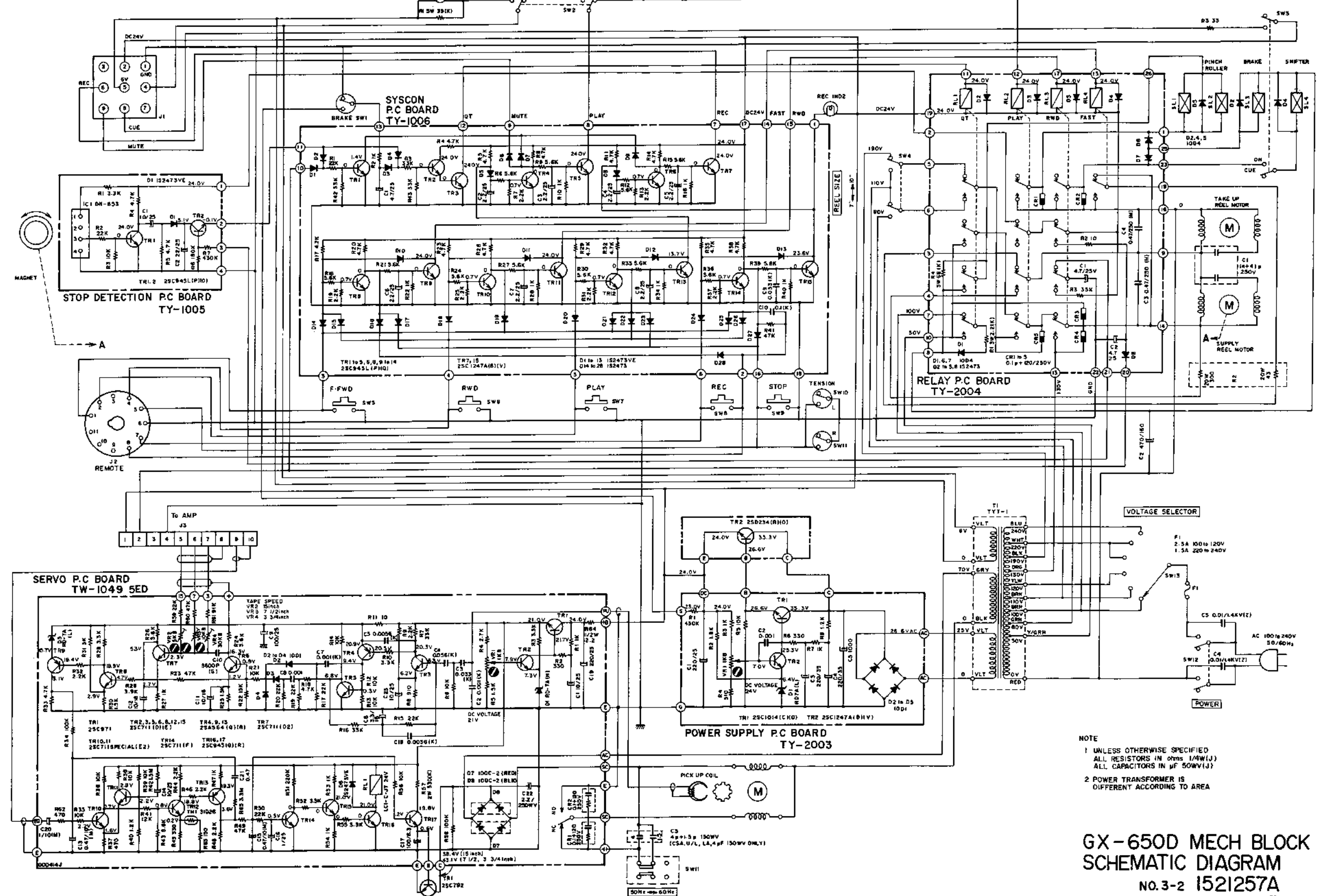

NOTE  
 1 UNLESS OTHERWISE SPECIFIED  
 ALL RESISTORS IN OHMS 1/4W(J)  
 ALL CAPACITORS IN  $\mu$ F 50WV(J)  
 2 POWER TRANSFORMER IS  
 DIFFERENT ACCORDING TO AREA

**GX-650D MECH BLOCK  
 SCHEMATIC DIAGRAM**  
 No. 3-2 1521257A

GX-650D

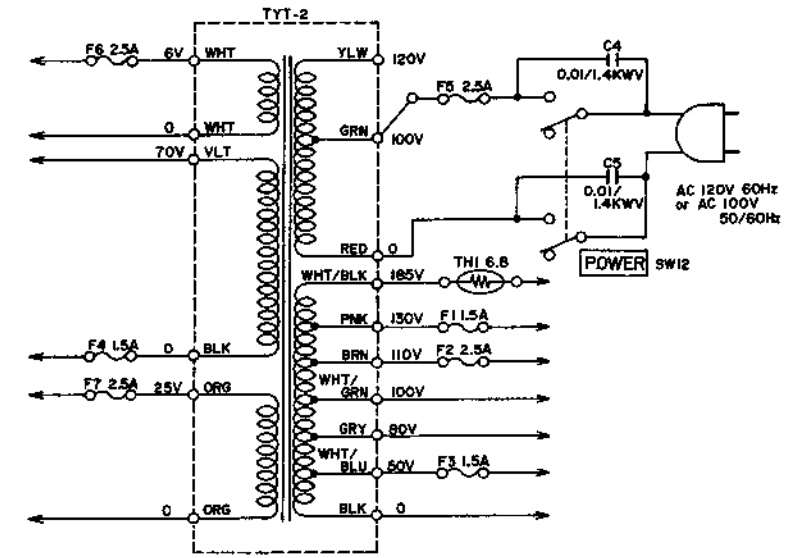

CSA/JPN

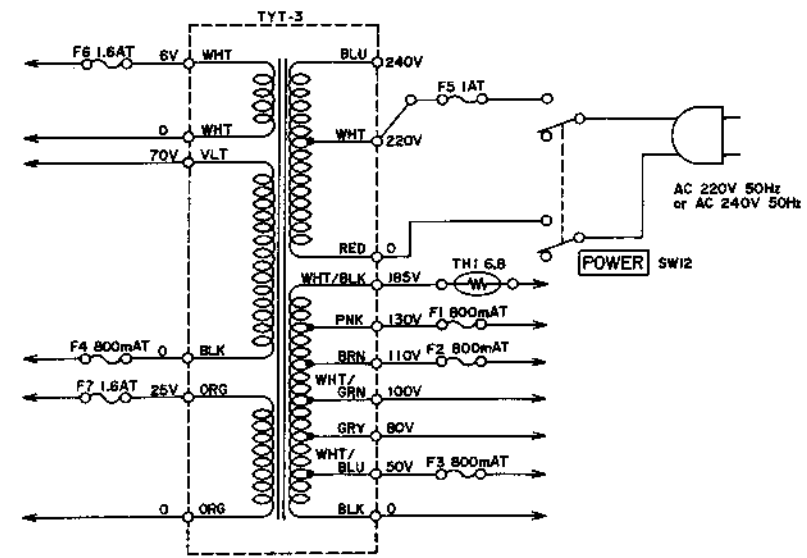

CEE/BSI

NOTE  
POWER TRANSFORMER IS  
DIFFERENT ACCORDING TO AREA

GX-650D  
POWER SUPPLY  
SCHEMATIC DIAGRAM  
NO. 3-3 1521258A

000801