

# SERVICE MANUAL

## PARTS LIST

**MODEL GX-635D**

**AKAI**

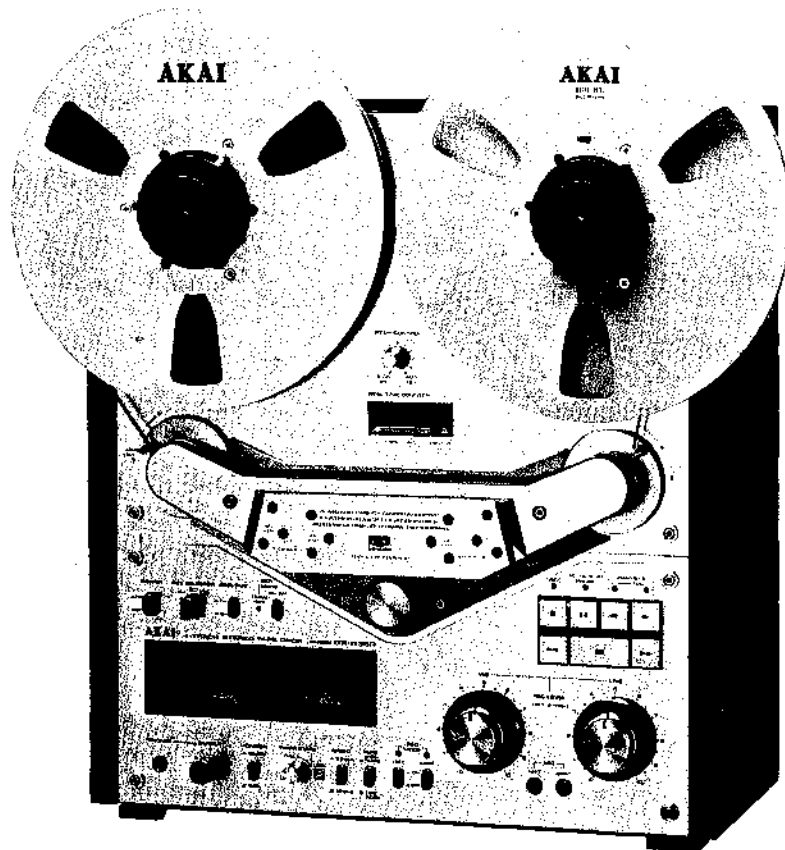

## STEREO TAPE DECK

MODEL **GX-635D**

SECTION 1 SERVICE MANUAL.....	1
SECTION 2 PARTS LIST.....	43
SECTION 3 SCHEMATIC DIAGRAM.....	67

---

---

SECTION 1

**SERVICE MANUAL**

TABLE OF CONTENTS

I.	TECHNICAL DATA .....	4
II.	DISMANTLING OF UNIT .....	5
III.	CONTROLS .....	7
IV.	PRINCIPAL PARTS LOCATION .....	8
V.	CIRCUIT OPERATING PRINCIPLES .....	10
	1. SYSTEM CONTROL OPERATION .....	10
	2. THE SAMPLE AND HOLD SYSTEM SERVO MOTOR (SCM-200) OPERATION .....	20
VI.	MECHANISM ADJUSTMENT .....	23
	1. GUIDE ROLLER LOOSE PLAY ADJUSTMENT .....	23
	2. TENSION MICRO SWITCH POSITION ADJUSTMENT .....	23
	3. ROLLER BLOCK HEIGHT ADJUSTMENT .....	23
	4. REEL TABLE HEIGHT ADJUSTMENT .....	24
	5. CAPSTAN SHAFT LOOSE PLAY ADJUSTMENT .....	24
	6. BRAKE BAND POSITION ADJUSTMENT AND BRAKE TENSION ADJUSTMENT .....	25
	7. PINCH ROLLER POSITION ADJUSTMENT .....	26
	8. PAUSE PLUNGER POSITION ADJUSTMENT .....	26
	9. PINCH ROLLER PRESSURE ADJUSTMENT .....	26
	10. TAPE SPEED ADJUSTMENT .....	27
VII.	HEAD ADJUSTMENT .....	28
VIII.	AMPLIFIER ADJUSTMENT .....	30
IX.	DC RESISTANCE OF VARIOUS COILS .....	32
X.	CLASSIFICATION OF VARIOUS P.C BOARDS .....	32
	1. P.C BOARD TITLES AND IDENTIFICATION NUMBERS .....	32
	2. COMPOSITION OF VARIOUS P.C BOARDS .....	33

For basic adjustments, measuring methods, and operating principles, refer to GENERAL TECHNICAL MANUAL.

# I. TECHNICAL DATA

TRACK SYSTEM	4 track 2 channel stereo/monaural system
REEL CAPACITY	Up to 10-1/2" reel
TAPE SPEED	19 cm/s $\pm 0.8\%$ (7-1/2 ips) 9.5 cm/s $\pm 1.0\%$ (3-3/4 ips) (Pitch control: more than $\pm 6\%$ )
WOW & FLUTTER	Less than 0.03% WRMS at 19 cm/s Less than 0.04% WRMS at 9.5 cm/s Less than 0.08% DIN 45500 at 19 cm/s Less than 0.10% DIN 45500 at 9.5 cm/s
FREQUENCY RESPONSE	30 to 27,000 Hz $\pm 3$ dB at 19 cm/s using WR Tape 30 to 21,000 Hz $\pm 3$ dB at 9.5 cm/s using WR Tape 30 to 25,000 Hz $\pm 3$ dB at 19 cm/s using LN Tape 30 to 19,000 Hz $\pm 3$ dB at 9.5 cm/s using LN Tape
DISTORTION (1,000 Hz "0" VU)	Less than 0.5% at 19 cm/s
SIGNAL TO NOISE RATIO	Better than 62 dB DIN 45500
ERASE RATIO	Better than 70 dB (at 1,000 Hz)
CROSS TALK	Better than 40 dB (at 1,000 Hz)
CHANNEL SEPARATION	Better than 55 dB (at 1,000 Hz)
BIAS FREQUENCY	100 kHz
HEADS	(6): Two GX Recording Heads, Two GX Playback Heads, Two Erase Heads
MOTORS	(3): One AC Servo Motor for Capstan Drive Two AC Eddy Current Motors for Reel Drive
REAL TIME COUNTER	Up to 99 min 59 sec. Less than $\pm 1.5\%$
FF & RWD TIME	120 sec using 550m (1,800 ft.) Tape
OUTPUT JACKS	Line (2): 0.775V (0 VU) Required load impedance: more than 20 kohms Phone (1): 100 mV/8 ohms
INPUT JACKS	Microphone (2): 0.25 mV Required microphone impedance: 600 ohms LINE (2): 70 mV impedance 100 kohms
DIN JACK	Input 2.0 mV, impedance 10 kohms, Output 0.3V
DIMENSIONS	440(W) $\times$ 483(H) $\times$ 256(D) mm, (17.4 $\times$ 19.0 $\times$ 10.1")
WEIGHT	21 kg (46.4 lbs)
POWER REQUIREMENT	100V, 50/60 Hz for JPN 120V, 60 Hz for US & Canada 220/240V, 50 Hz for Europe, UK and Australia 110/120/220/240V, 50/60 Hz internally switchable for other countries

\* Specifications determined with Akai LN-150-7 or SCOTCH #211 tape unless otherwise noted.

\* For improvement purposes, specifications and design are subject to change without notice.

## II. DISMANTLING OF UNIT

In case of trouble, etc. necessitating dismantling, please dismantle in the order shown in the photographs. Reassemble in reverse order.

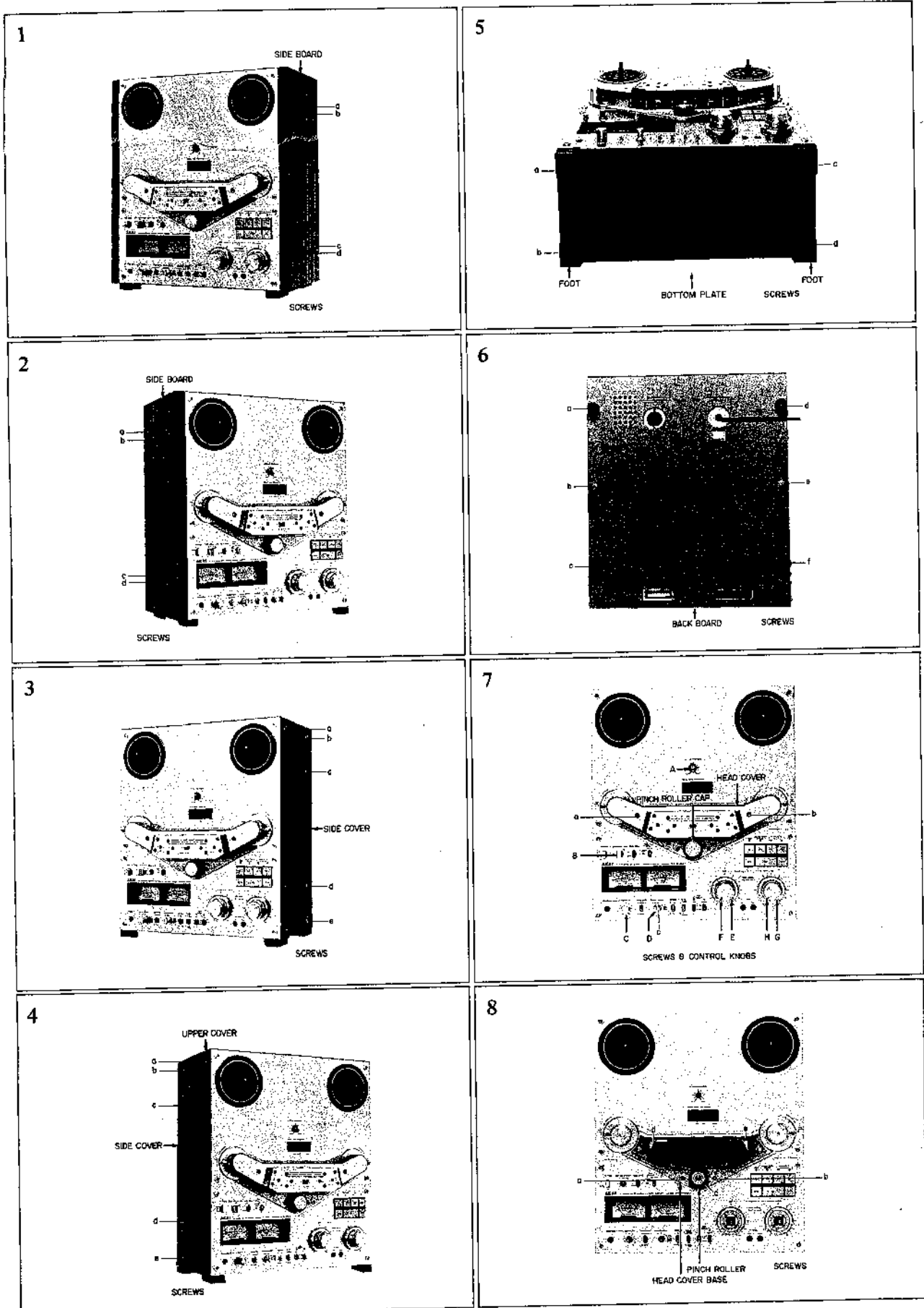

9

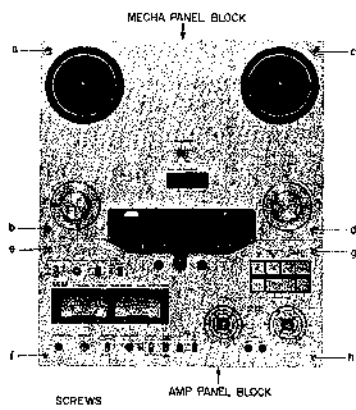

10

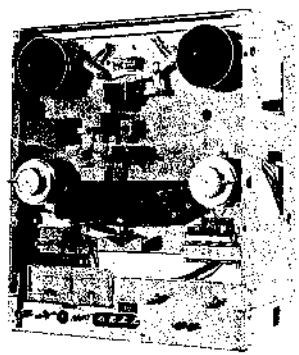

### III. CONTROLS

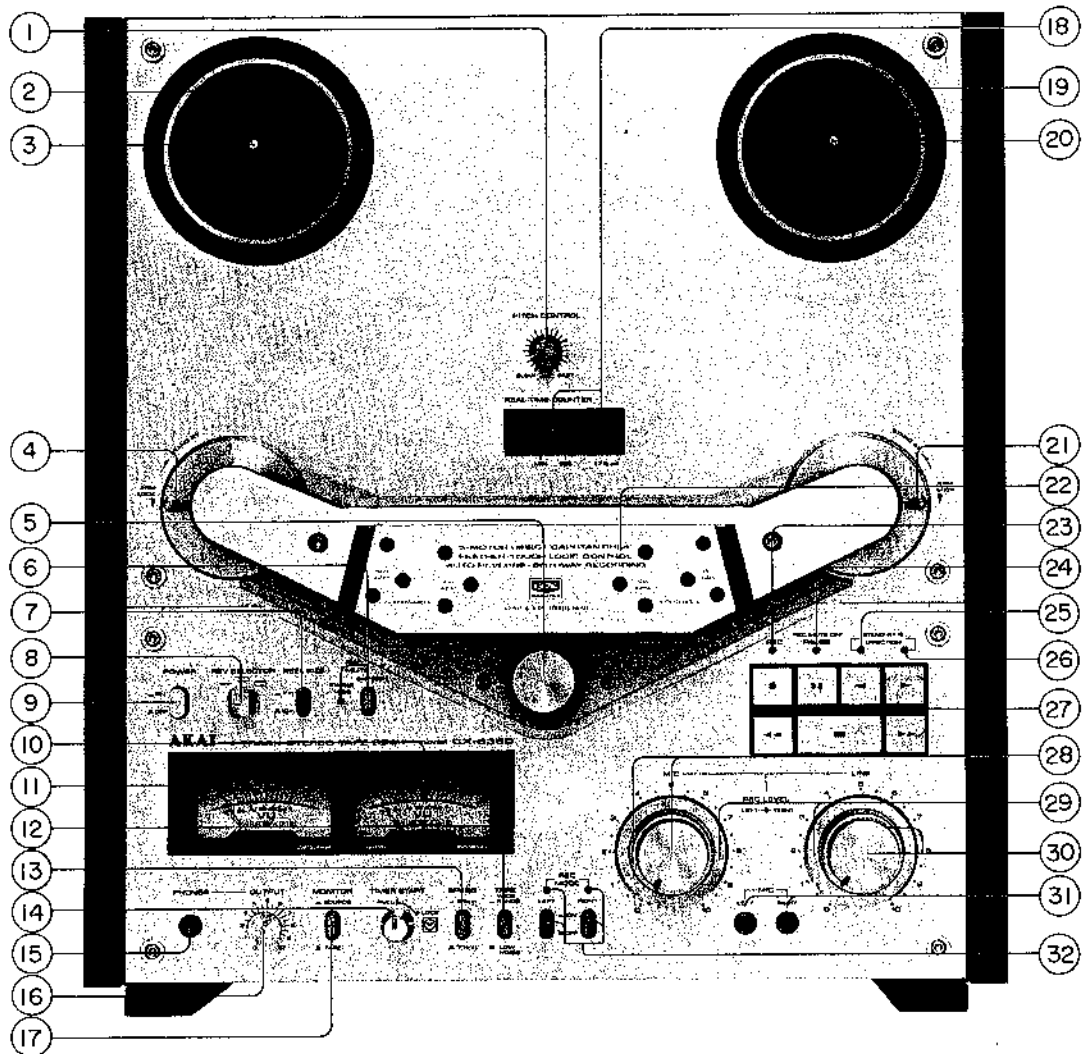

Fig. 1 Controls

- |   |   |
|---|---|
| 1. PITCH CONTROL                                | 17. MONITOR SWITCH                            |
| 2. SUPPLY REEL TABLE                            | 18. REAL TIME COUNTER and RESET BUTTON        |
| 3. BUILT-IN REEL RETAINER (Left)                | 19. TAKE-UP REEL TABLE                        |
| 4. LEFT TENSION ARM                             | 20. BUILT-IN REEL RETAINER (Right)            |
| 5. PINCH ROLLER                                 | 21. RIGHT TENSION ARM                         |
| 6. RECORDING MUTE SWITCH (REC MUTE)/TIMING LAMP | 22. HEAD COVER                                |
| 7. REEL SIZE SELECTOR                           | 23. RECORDING INDICATOR LAMP                  |
| 8. REVERSE SELECTOR                             | 24. PAUSE INDICATOR LAMP                      |
| 9. POWER SWITCH                                 | 25. REVERSE DIRECTION/STAND BY INDICATOR LAMP |
| 10. VU METER (Right)                            | 26. FORWARD DIRECTION/STAND BY INDICATOR LAMP |
| 11. VU METER (Left)                             | 27. MODE BUTTONS                              |
| 12. TAPE SELECTOR                               | 28. MICROPHONE INPUT CONTROLS                 |
| 13. TAPE SPEED SELECTOR                         | 29. MEMORY MARKERS                            |
| 14. TIMER START                                 | 30. LINE INPUT CONTROLS                       |
| 15. HEADPHONE JACK                              | 31. MICROPHONE JACKS (Left/Right)             |
| 16. OUTPUT LEVEL CONTROL                        | 32. RECORDING MODE SWITCH                     |



# IV. PRINCIPAL PARTS LOCATION

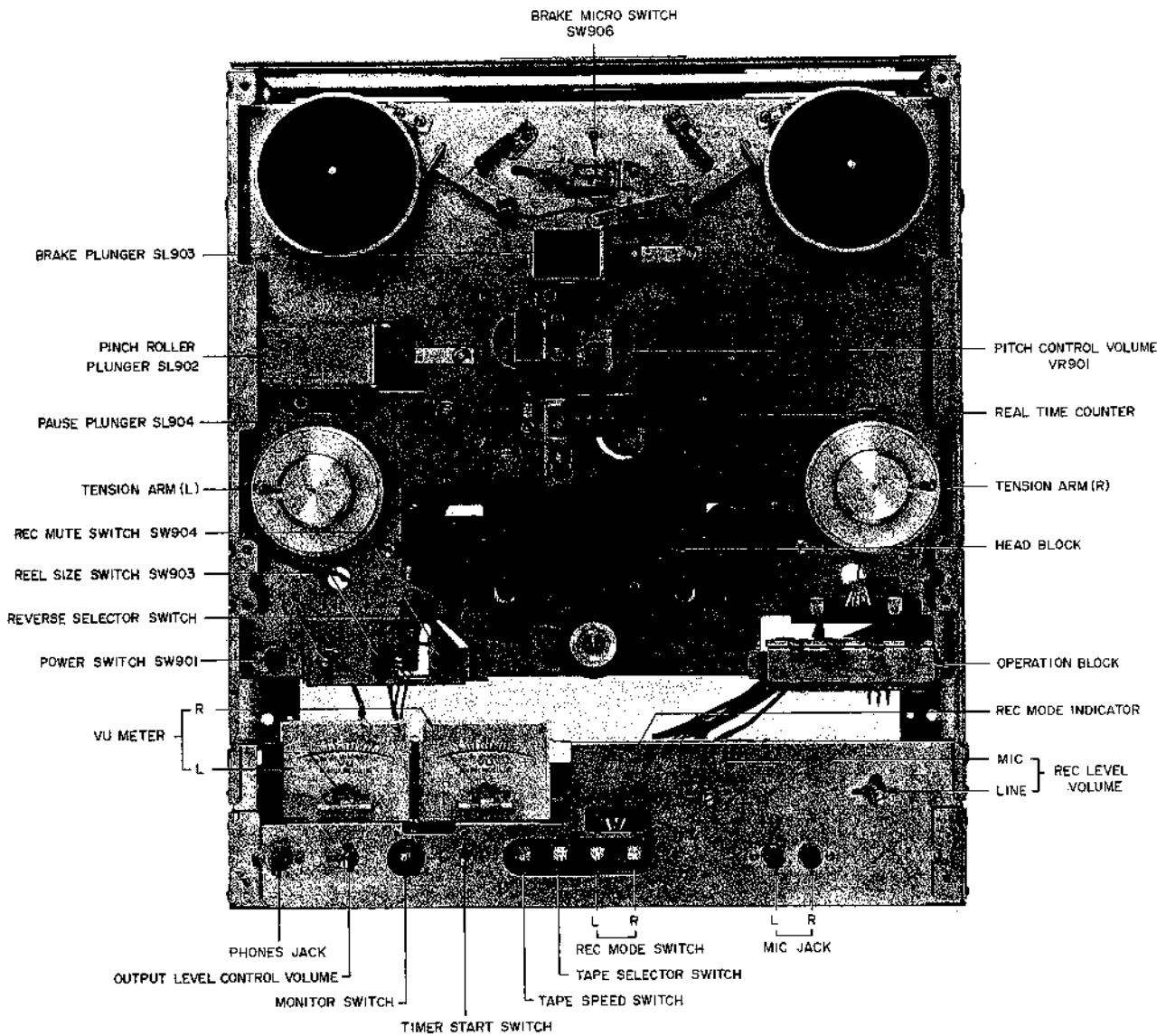

Fig. 2 Front View

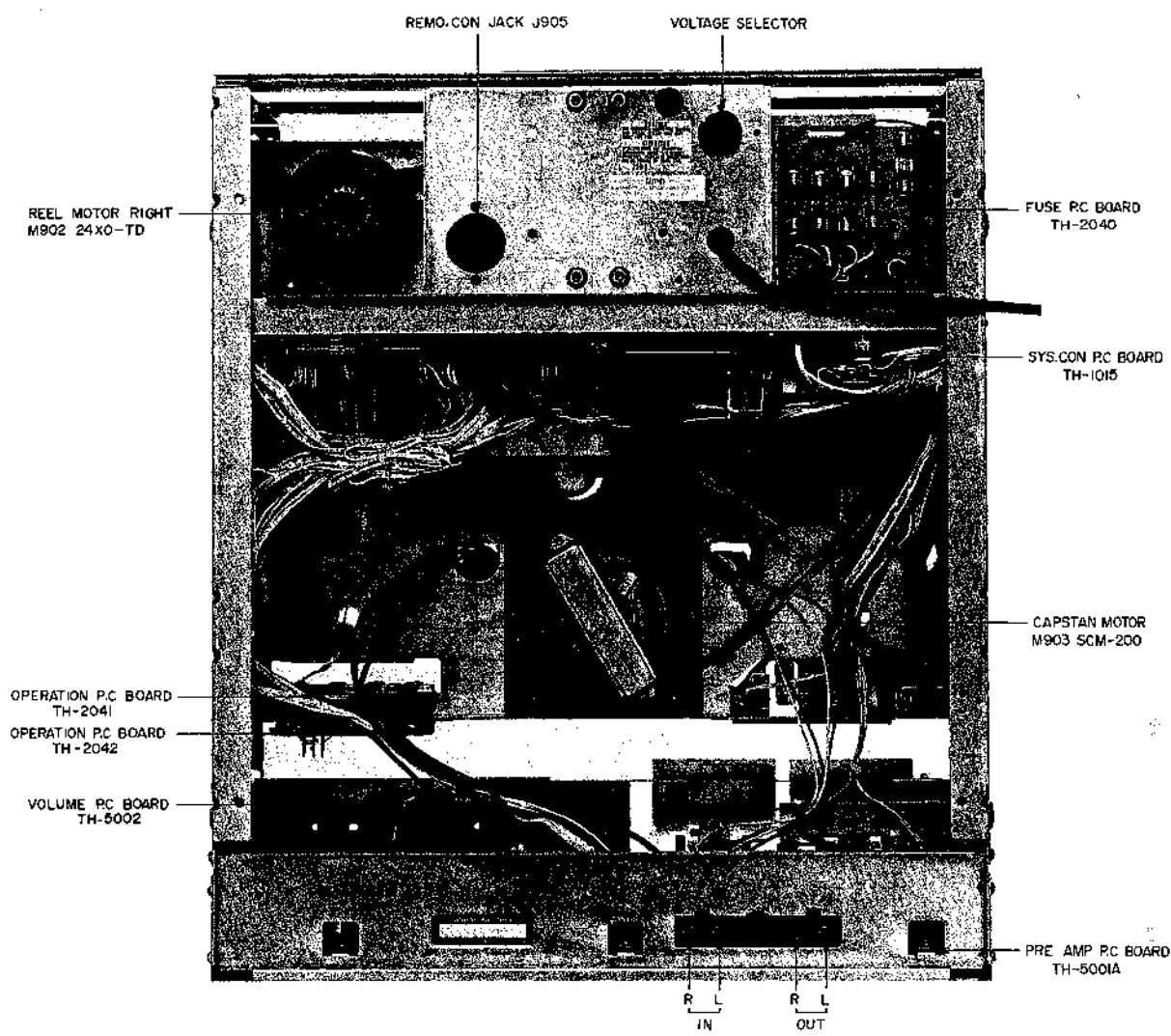

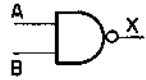
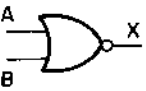

Fig. 3 Rear View

# V. CIRCUIT OPERATING PRINCIPLES

## 1. SYSTEM CONTROL OPERATION

	SYMBOL	TRUTH TABLE															
NOT CIRCUIT	 $X = \bar{A}$	<table border="1"> <thead> <tr> <th>A</th> <th>X</th> </tr> </thead> <tbody> <tr> <td>0</td> <td>1</td> </tr> <tr> <td>1</td> <td>0</td> </tr> </tbody> </table>	A	X	0	1	1	0									
A	X																
0	1																
1	0																
NAND CIRCUIT	 $X = \overline{A \cdot B}$	<table border="1"> <thead> <tr> <th>A</th> <th>B</th> <th>X</th> </tr> </thead> <tbody> <tr> <td>0</td> <td>0</td> <td>1</td> </tr> <tr> <td>1</td> <td>0</td> <td>1</td> </tr> <tr> <td>0</td> <td>1</td> <td>1</td> </tr> <tr> <td>1</td> <td>1</td> <td>0</td> </tr> </tbody> </table>	A	B	X	0	0	1	1	0	1	0	1	1	1	1	0
A	B	X															
0	0	1															
1	0	1															
0	1	1															
1	1	0															
NOR CIRCUIT	 $X = \overline{A + B}$	<table border="1"> <thead> <tr> <th>A</th> <th>B</th> <th>X</th> </tr> </thead> <tbody> <tr> <td>0</td> <td>0</td> <td>1</td> </tr> <tr> <td>1</td> <td>0</td> <td>0</td> </tr> <tr> <td>0</td> <td>1</td> <td>0</td> </tr> <tr> <td>1</td> <td>1</td> <td>0</td> </tr> </tbody> </table>	A	B	X	0	0	1	1	0	0	0	1	0	1	1	0
A	B	X															
0	0	1															
1	0	0															
0	1	0															
1	1	0															

0 = LOW LEVEL  
1 = HIGH LEVEL

Chart-1

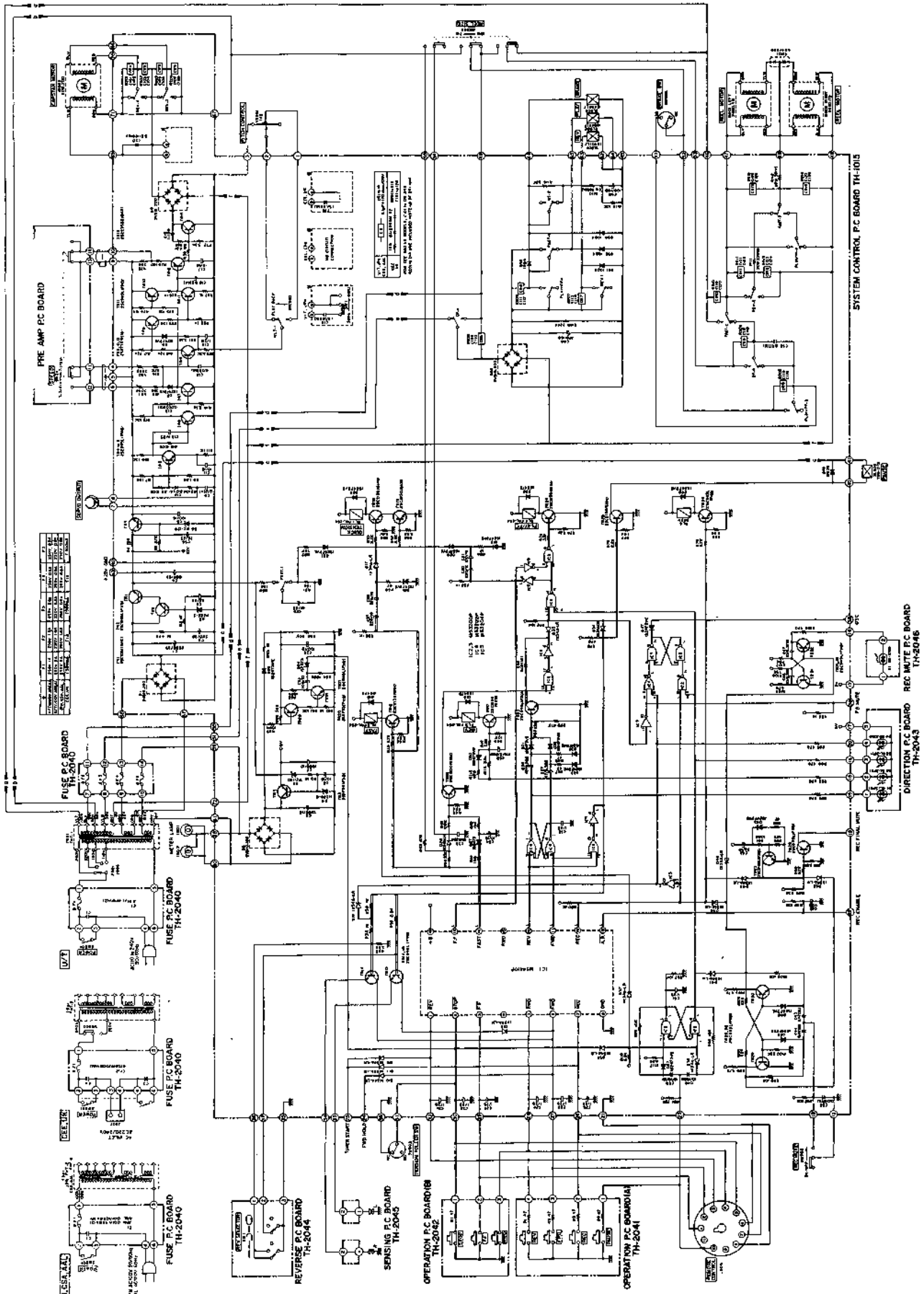

Schematic-1 STOP MODE

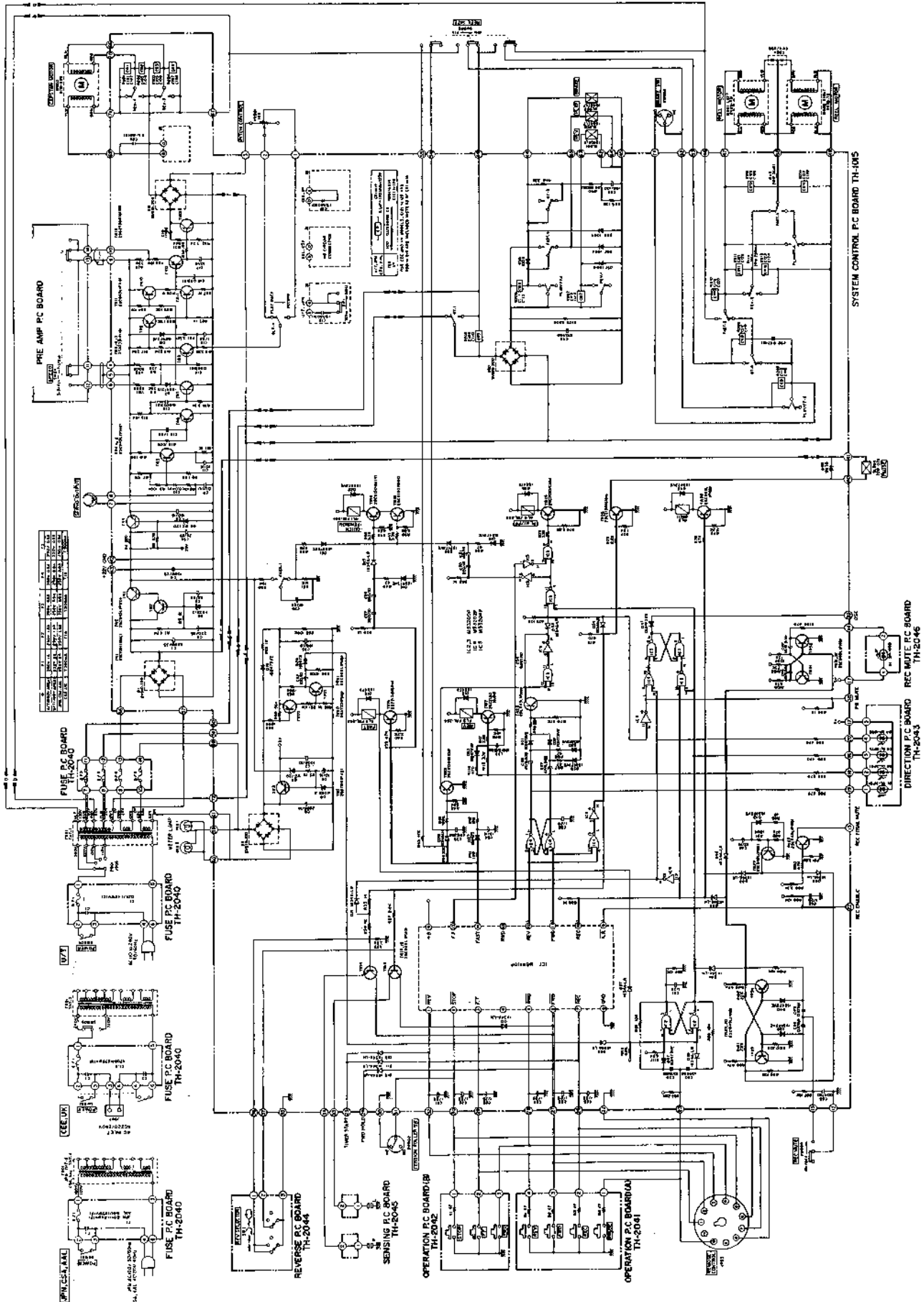

Schematic-2 FWD-PLAY MODE

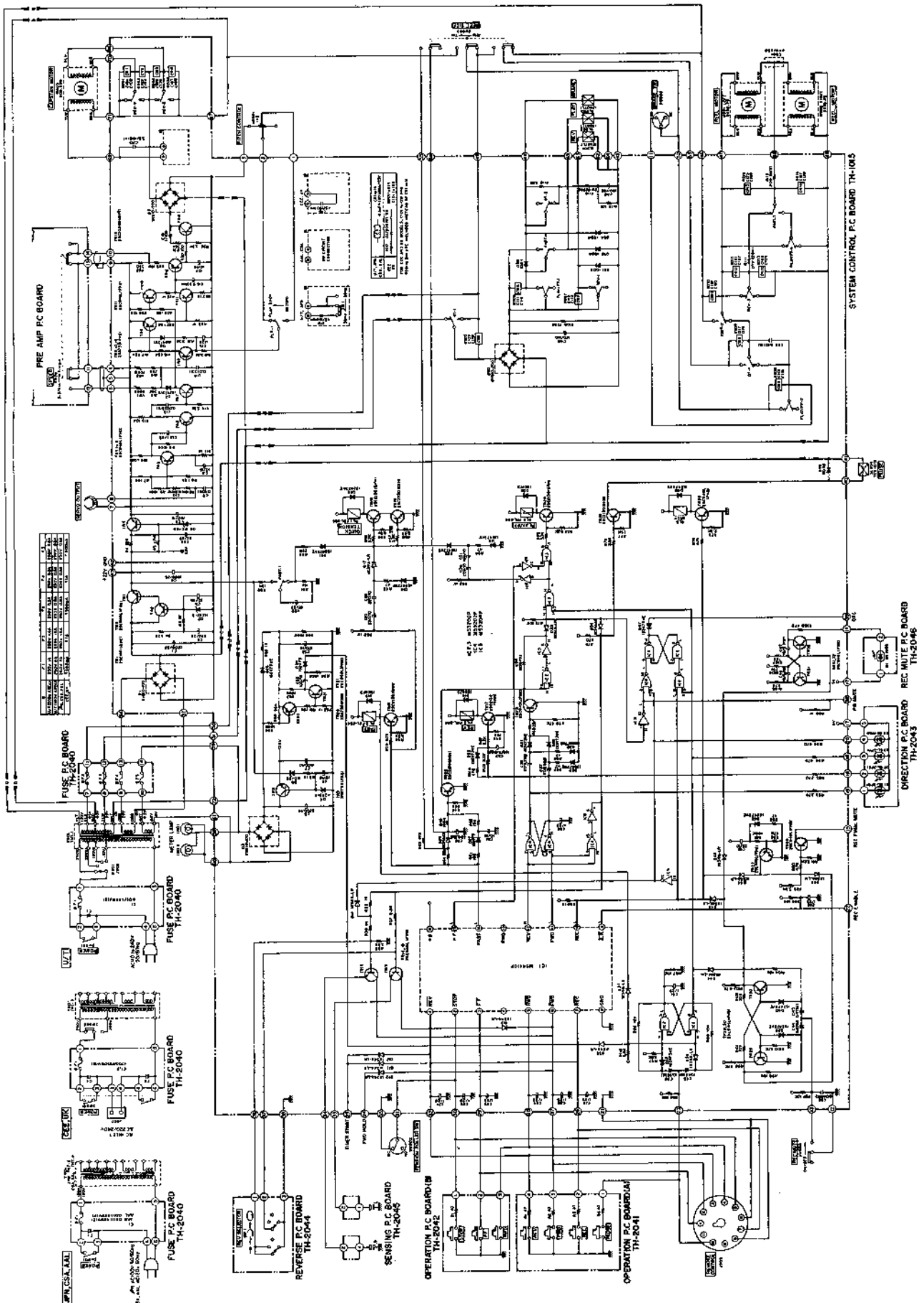

Schematic-3 REV-PLAY MODE

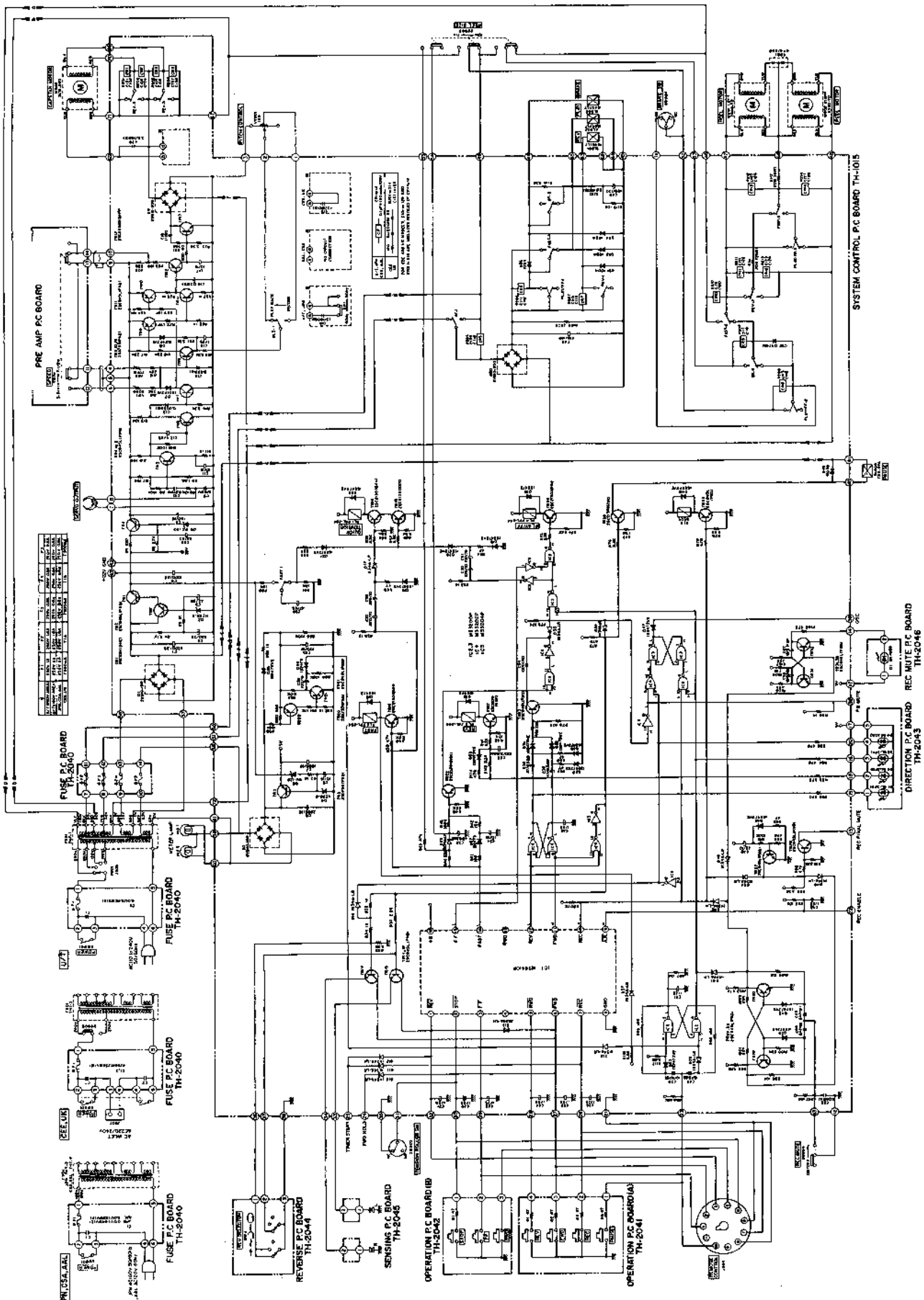

Schematic-4 FWD-REC MODE

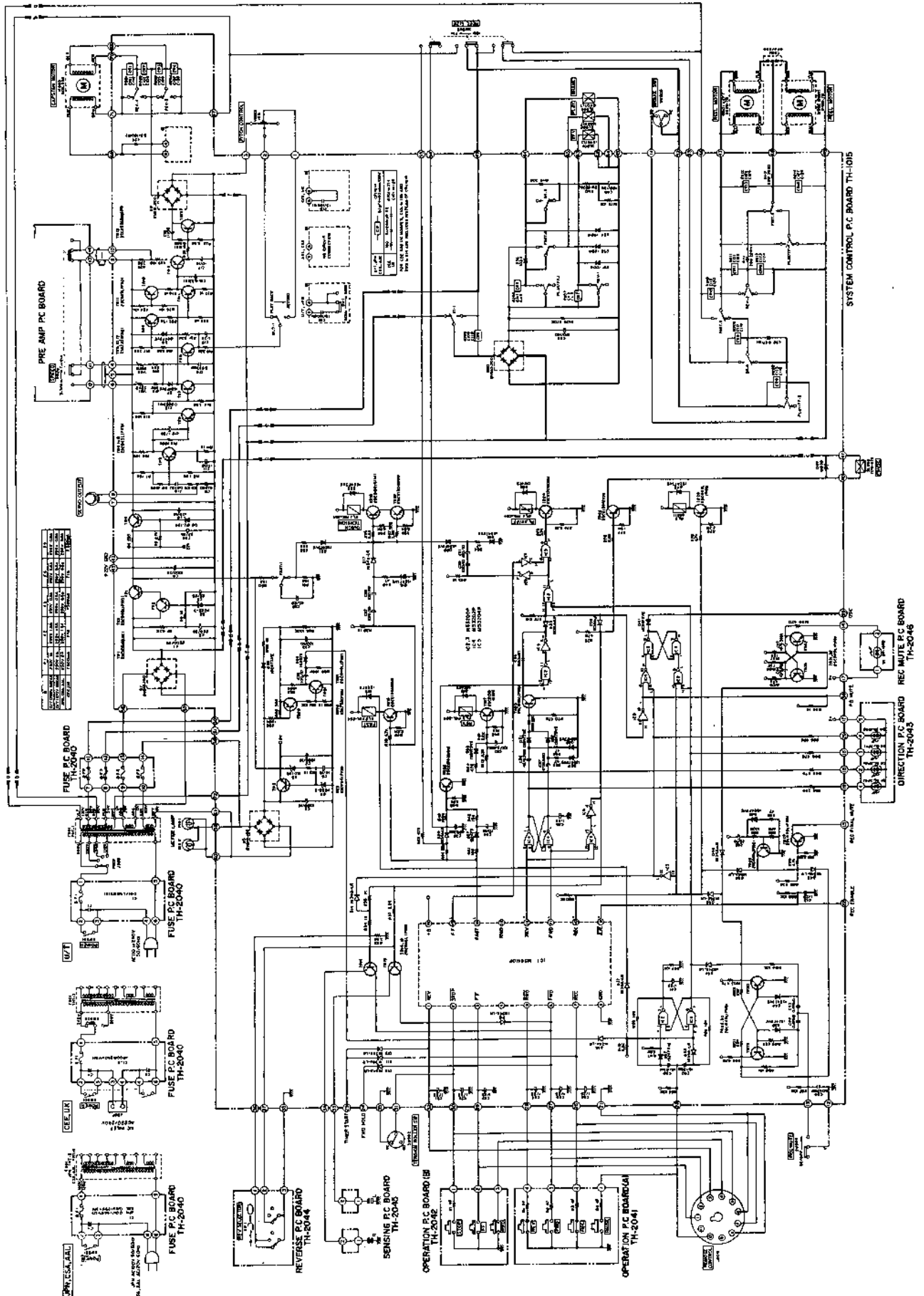

Schematic-5 REV-REC MODE



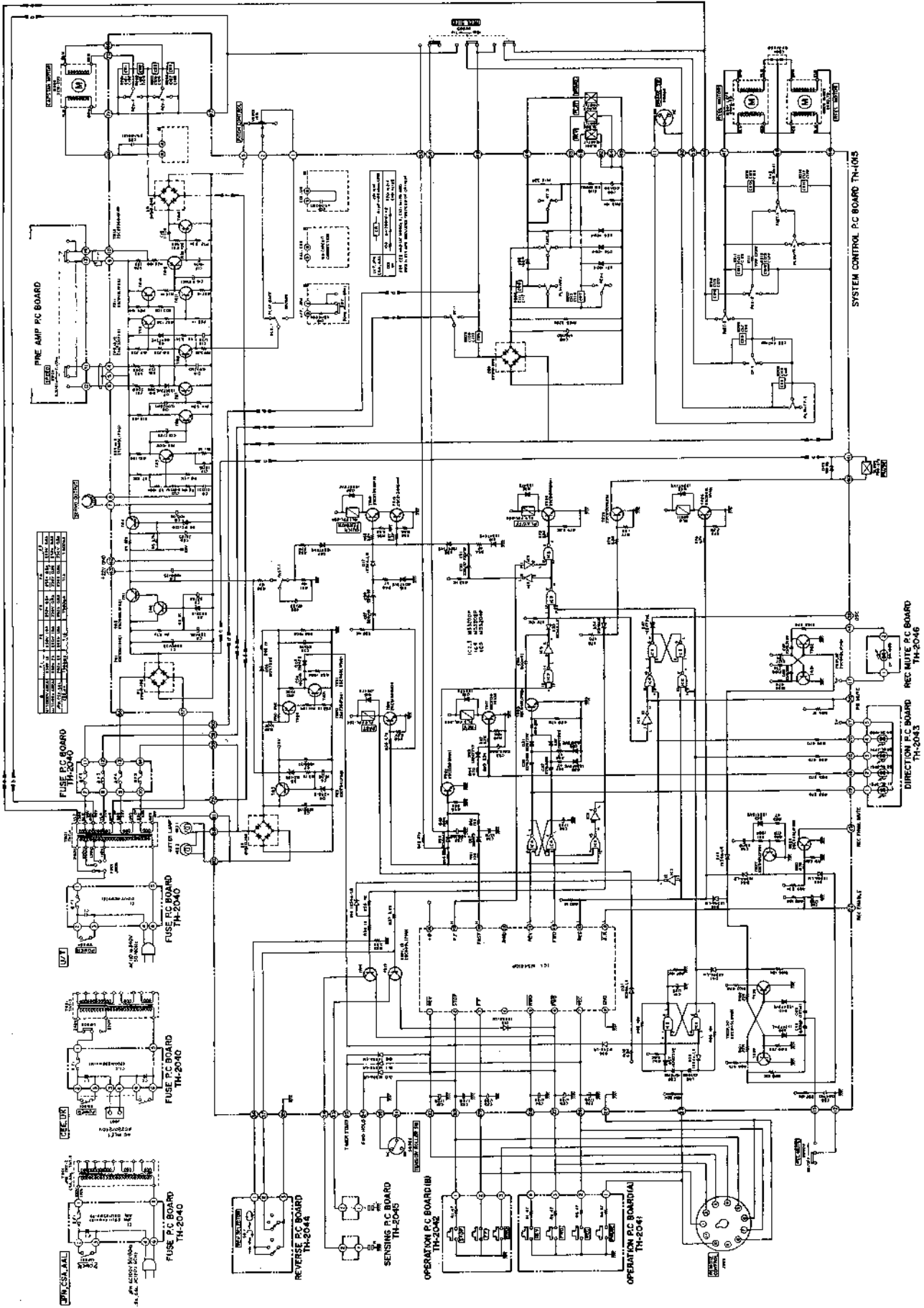

Schematic-6 FF MODE

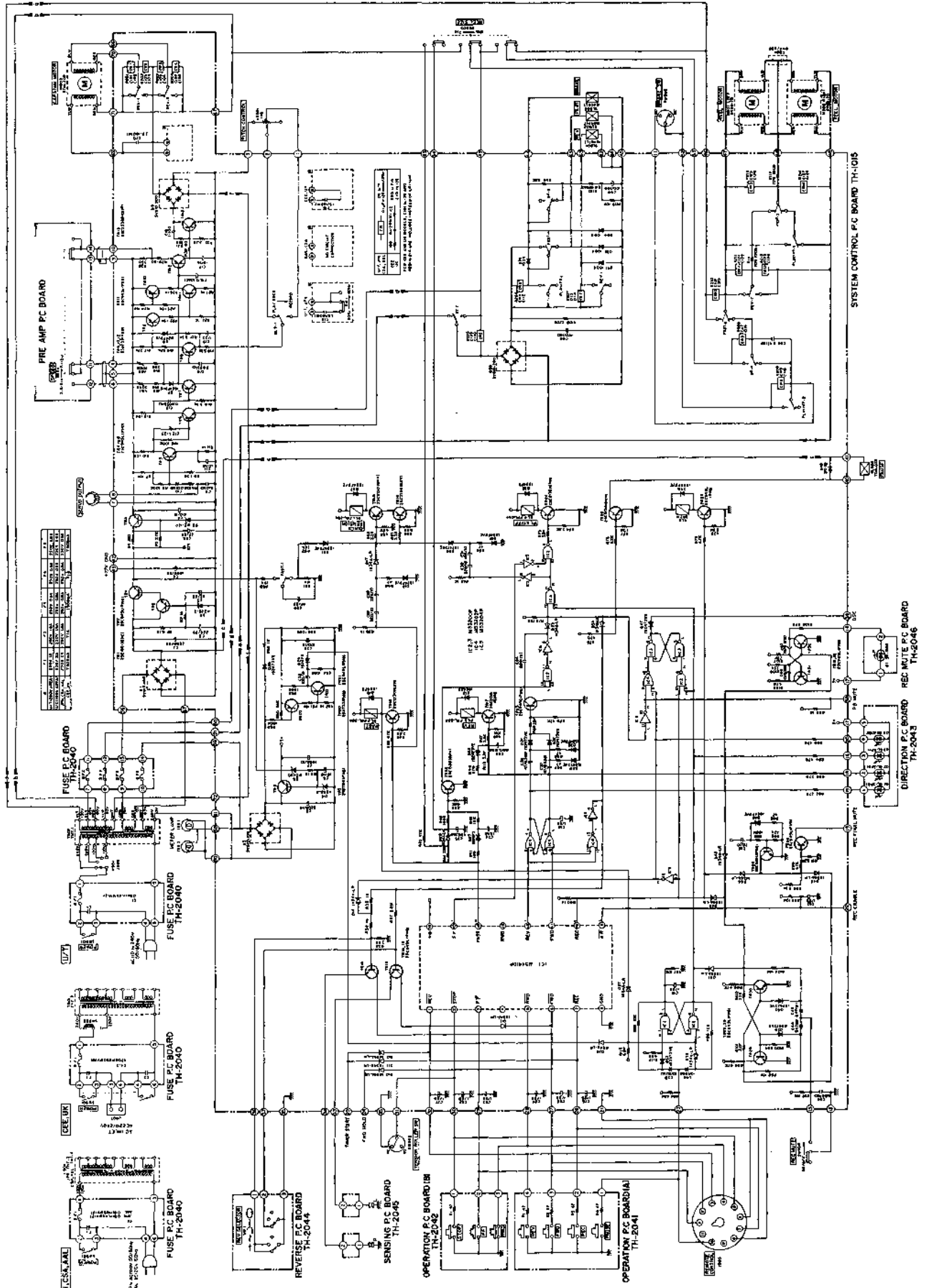

Schematic-7 RWD MODE

**1-1. CIRCUIT CONSTRUCTION OF IC1 M54410P**

The design of M54410P until now had STOP, PLAY, REC, FF, RWD, PAUSE and REC preventing AR as its input terminals. GX-635D circuit is constructed with FWD in place of PAUSE and REV in place of PLAY. Pause is controlled by a flip flop with a separate IC.

**1) Block Diagram**

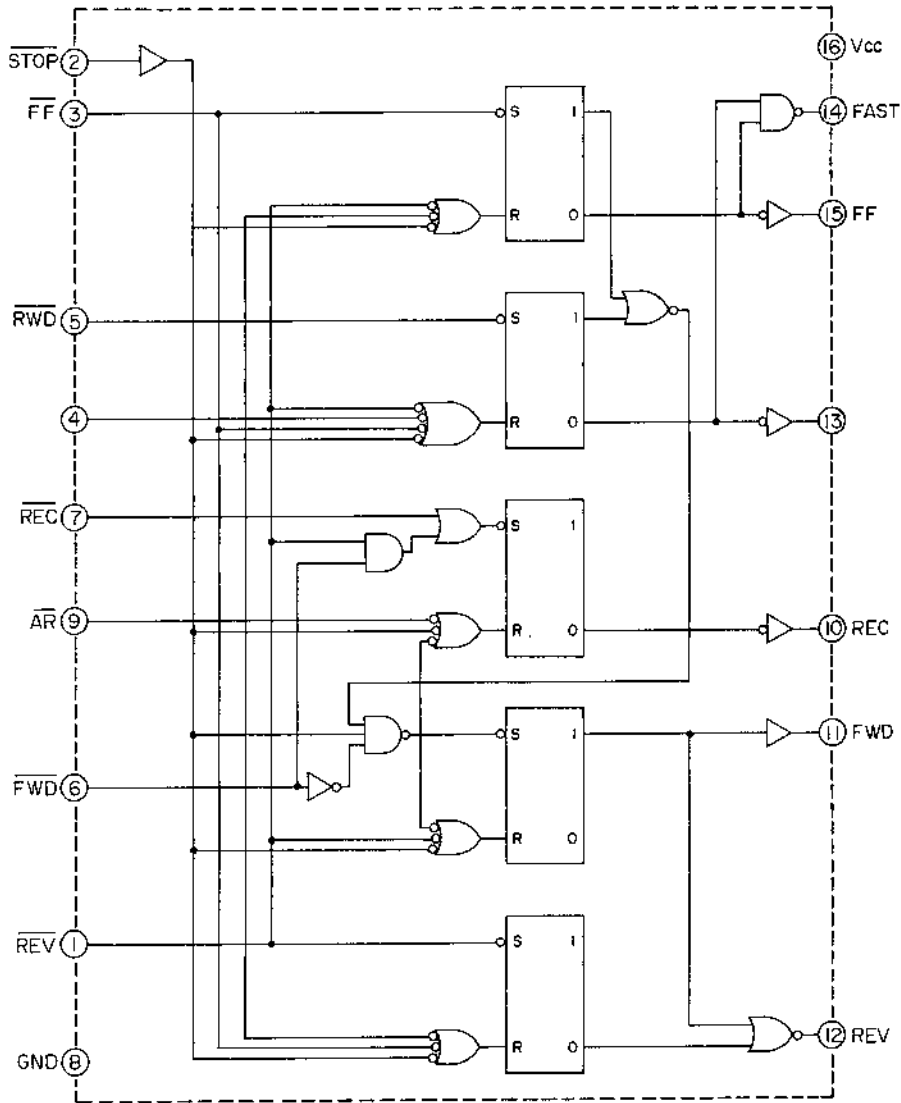

Fig. 4 M54410P

## 2) Terminals and their functions

	Terminal Name	Terminal Function
Operation input terminals	$\overline{\text{STOP}}$	Input terminal for stopping operation
	$\overline{\text{FF}}$	Input terminal for fast forward
	$\overline{\text{RWD}}$	Input terminal for rewind
	$\overline{\text{FWD}}$	Input terminal for playback in the forward direction
	$\overline{\text{REV}}$	Input terminal for playback in the reverse direction
	$\overline{\text{REC}}$	Input terminal for recording
Control input terminal $\overline{\text{AR}}$		Input terminal for preventing recording
Output terminals	$\overline{\text{FAST}}$	Terminal with "H" signal output during fast forward or rewind mode
	$\overline{\text{FF}}$	Terminal with "H" signal output during fast forward mode
	$\overline{\text{FWD}}$	Terminal with "H" signal output during forward playback mode
	$\overline{\text{REV}}$	Terminal with "H" signal output during reverse playback mode
	$\overline{\text{REC}}$	Terminal with "H" signal output during recording or REC/Pause mode

Chart-2

## 3) Operation activated by each input

Input Signal	Output					Output Mode
	$\overline{\text{FAST}}$	$\overline{\text{FF}}$	$\overline{\text{FWD}}$	$\overline{\text{REV}}$	$\overline{\text{REC}}$	
$\overline{\text{STOP}}$	L	L	L	L	L	STOP Mode
$\overline{\text{FF}}$	H	H	L	L	L	FF Mode
$\overline{\text{RWD}}$	H	L	L	L	L	RWD Mode
$\overline{\text{FWD}}$	L	L	H	L	L	FWD Mode
$\overline{\text{REV}}$	L	L	L	H	L	REV Mode
$\overline{\text{REC/FWD}}$	L	L	H	L	H	REC/FWD Mode
$\overline{\text{REC/REV}}$	L	L	L	H	H	REC/REV Mode

Chart-3

- NOTES:**
1. The input signal is activated by the fall of  $\square$ .
  2. The output is maintained until the next input signal.
  3.  $\overline{\text{AR}}$  is a control input terminal and the REC output is not "H" when  $\overline{\text{AR}} = \text{"L"}$ .
  4. When  $\overline{\text{AR}} = \text{"L"}$  signal is supplied during the REC output is "H", REC output becomes "L".
  5. At the moment the power is on, all output will be "L" and the Stop mode will be effected.

## 4) Regarding the input circuit's diode D13

Previously M54410P has been so designed that the first terminal was  $\overline{\text{PLAY}}$  input and the sixth terminal was  $\overline{\text{PAUSE}}$  input. But in GX-635D,  $\overline{\text{PLAY}}$  is used for  $\overline{\text{REV}}$  and  $\overline{\text{PAUSE}}$  for  $\overline{\text{FWD}}$ . Consequently, grounding only the 6th terminal ( $\overline{\text{FWD}}$ ) will not allow the modes to be changed

directly from FF or RWD to FWD. For this reason, the first terminal ( $\overline{\text{REV}}$ ) is also grounded through diode D13 releasing FF and RWD. In addition, even if there are simultaneous inputs into both  $\overline{\text{FWD}}$  and  $\overline{\text{REV}}$ , FWD mode output is designed to take priority.

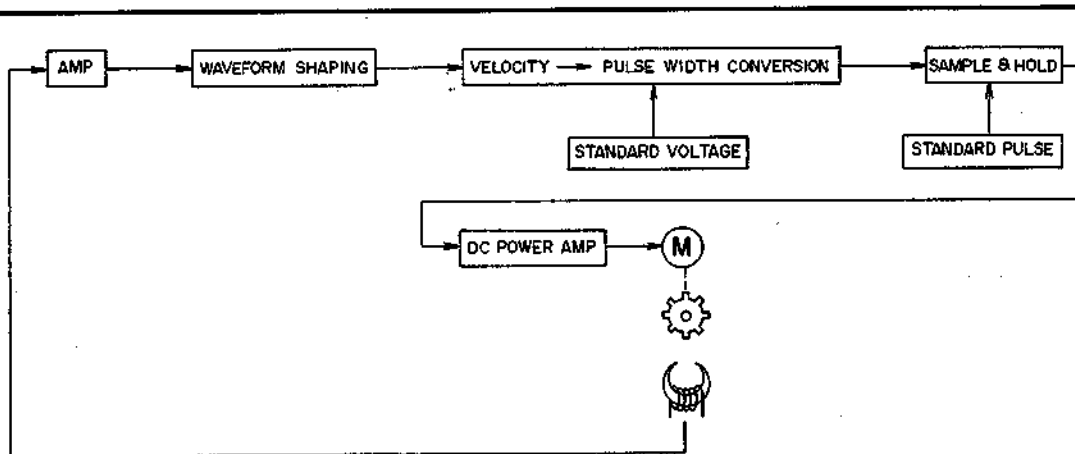

Fig. 5 Block Diagram

## 1-2. CIRCUIT FOR PREVENTING CLICK NOISE DURING TIMER RECORDING

- 1) When the power is turned on for timer recording, recording must take place after the amplifier circuit is in full operation or else click noise will be recorded. Also when the power is turned off, Rec Final Mute must operate before the amplifier circuit ceases to operate or else click noise will be recorded. This circuit prevents such click noise from being recorded.
- 2) In ordinary recording, base electric current flows to TR28 base through R89 and R90, and TR28 is ON. Therefore, Rec Final Mute relay RL1 (Pre Amp P.C Board) connected to TR28 collector is operating to supply the signals to the recording head and the recording mode is effected.
- 3) When the power is turned ON at timer recording stand-by, base electric current is supplied to TR27 base only while C42 is being charged and TR27 is turned ON. When TR27 is turned ON, electric potential is not supplied to TR28 base and TR28 is turned off. Consequently relay RL1 does not operate and Rec head is not supplied with a signal. Since TR27 turns off once C42 is charged, base electric current flows to TR28 base through R89 and R90.  
Because relay RL1 function only after the amplifier circuit is in complete operation, the click noise is avoided.
- 4) TR20 and TR21 is OFF during recording mode and for this reason C32 and C33 are charged.  
When the power is turned off in this condition, by the charging voltage on C33 TR20 base will become lower than the emitter in electric potential and turns ON. TR21 is also supplied with electric current thereby and is turned on. When TR21 is turned on, C32 is discharged, and IC1 terminal 2 (Stop) becomes ground potential through D24. This releases the deck from the recording mode and the stop mode is effected.  
This operation takes place before the amplifier circuit stops and therefore the click noise is cut out.

## 2. THE SAMPLE AND HOLD SYSTEM SERVO MOTOR (SCM-200) OPERATION

- 1) Servo signals generally created proportionately to the number of revolutions of the motor are shown either as frequency deviations or voltage deflections. The motor employed in GX-635D uses frequency deviation unaffected by time constants, etc., of the load circuit as input signal to the motor drive circuit through pulse width conversion.  
This pulse width varies proportionately to the deviations in the number of motor rotations. The deviation is detected, converted to a voltage value, is held at that voltage until the next servo signal pulse, and then impressed into the motor drive circuit.  
Meanwhile, since it requires a holding circuit and because 112 pulse are generated for each motor rotation, time constants of circuits coming before the Sample and Hold circuit can be greatly reduced compared to the conventional voltage deflection detection system.  
For the reasons above, it features quick response to motor revolutions, minimum influence by temperature, and fewer chances of faulty mechanism. In addition, due to the inclusion of the servo voltage holding circuit, ripple content of the servo voltage has been sharply reduced to result in a smooth and stable tape transport with a minimum of wow & flutter.

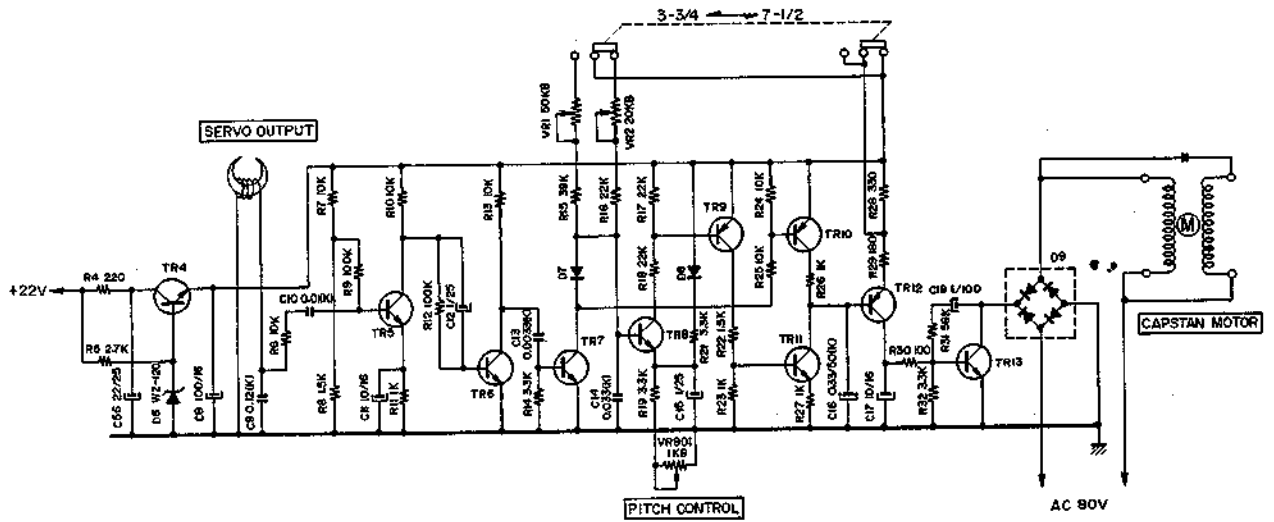

Fig. 6

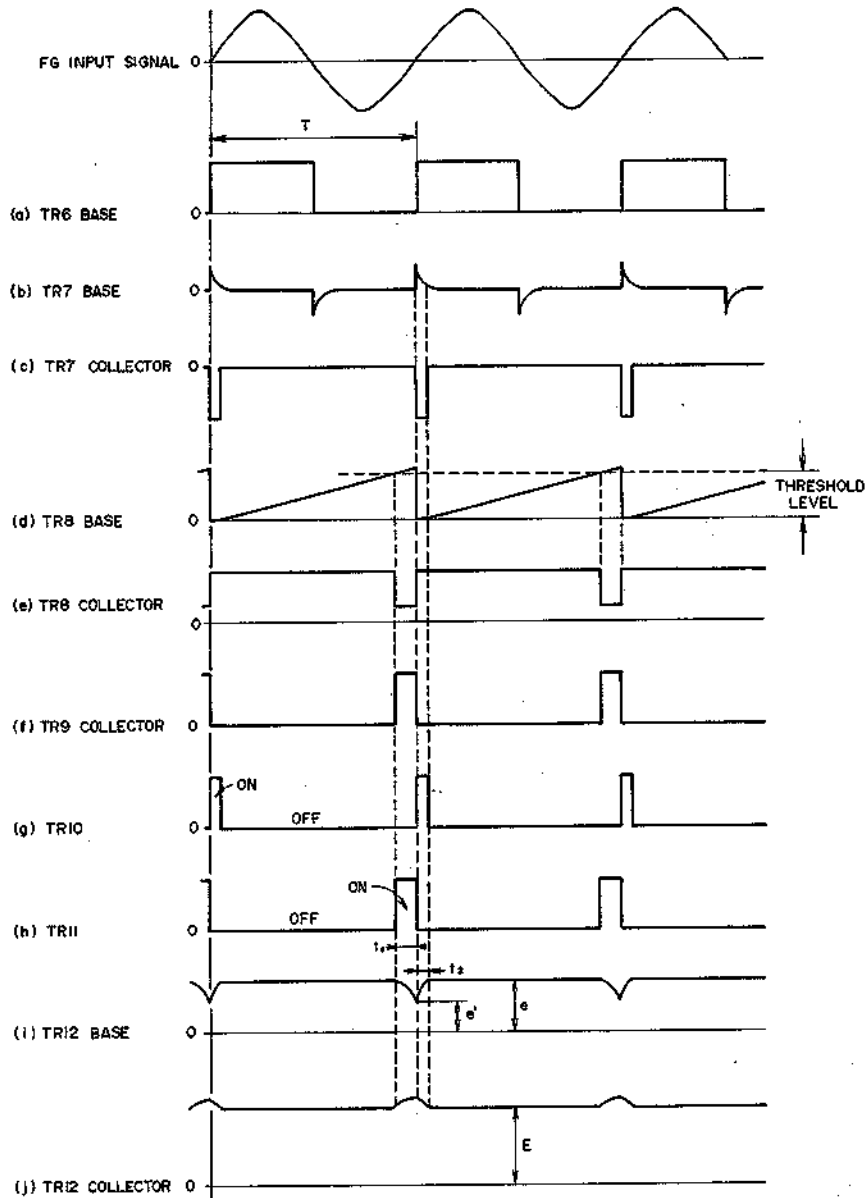

Fig. 7

---

2) Explanation of the circuit operation (Refer to Figs. 6, 7)

The velocity signal obtained from the motor's frequency generator is shaped into a waveform in the period of "T" proportionate to the velocity as in (a) on collector TR6. This signal is differentiated and enters TR7 base. This makes TR7's collector output as in (c) and turns ON TR10 during the time of the negative pulse.

Meanwhile TR8 base is supplied with a waveform like (d) and when it reaches the threshold level, TR8 is turned on. A waveform (e) with pulse width " $t_1$ " is obtained from the collector. During the time "T" that TR28 is ON, TR9 base electric potential decreases to turn ON.

Consequently, TR11 base electric potential increases and TR11 is also turned ON for the time " $t_1$ ".

When the period "T" varies with the velocity, the pulse width " $t_1$ " varies according to TR8's threshold level. But when TR10 is on, it is constant due to the time constant. So that by using the period that TR is ON as the standard pulse, the pulse width " $t_2$ " is constant regardless of the velocity.

(g) and (h) show the ON and OFF condition of TR10 and TR11. When the electric charge that was charged to C16 is discharged during the time TR11 is ON " $t_1$ ", a signal voltage of "e" proportionate to the velocity can be obtained. Next, with "e" as its basis, C16 is charged during the limited time of the standard pulse width " $t_2$ ", and by the charging voltage "e" the charging is stopped. The voltage is then held until the next standard pulse.

This voltage "e" is supplied to the TR12 base and a servo signal "E" is obtained. This servo signal "E" controls TR13 and drives the motor.

As shown above, since " $t_1$ " and " $t_2$ " are small, servo signal ripples are made small and a near direct current servo signal is obtained. In addition, the time constants of the smoothing circuit can also be made small that phase lag factor can be minimized.

## VI. MECHANISM ADJUSTMENT

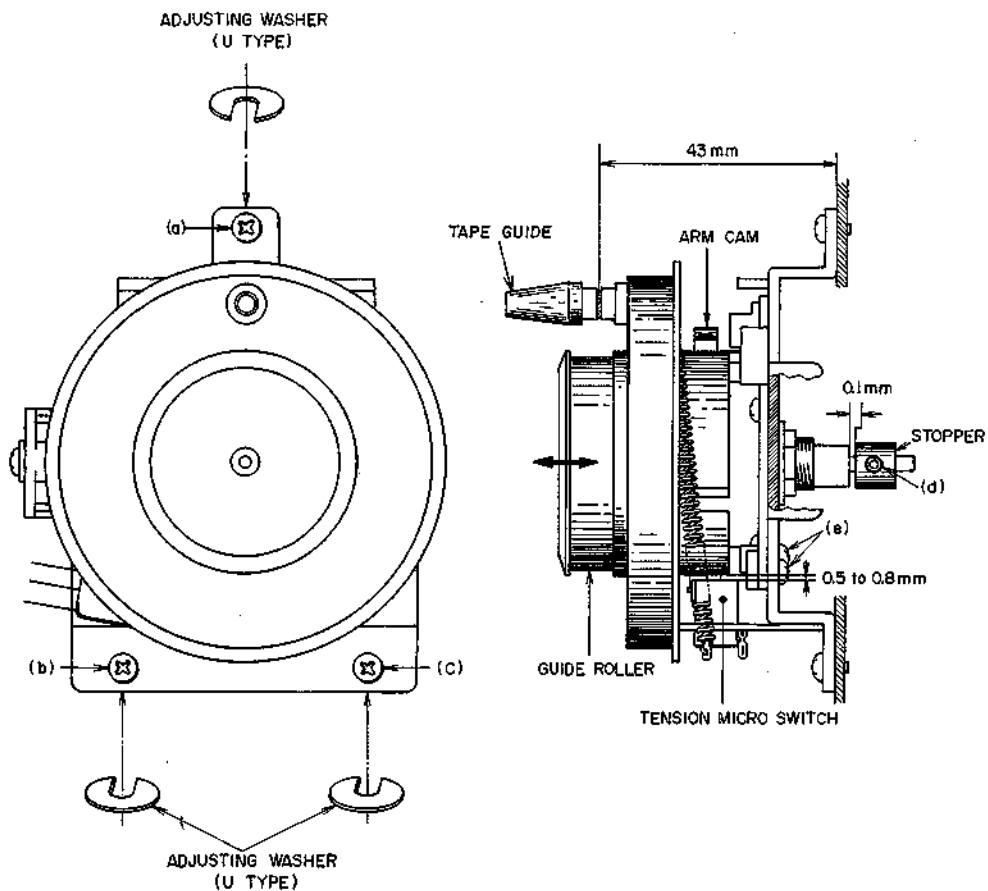

Fig. 8 Roller Block

### 1. GUIDE ROLLER LOOSE PLAY

#### ADJUSTMENT (Refer to Fig. 8)

Adjust the stopper (roller pulley on the right) screw (d) so that the loose play gap is approximately 0.1 mm when the guide roller is moved as indicated by arrow mark in Fig. 8.

### 2. TENSION MICRO SWITCH POSITION

#### ADJUSTMENT (Refer to Fig. 8)

Adjust the screws (e) so that the gap between the arm cam and the micro switch is approximately 0.5 to 0.8 mm. Check that the micro switch works and that the arm lock smoothly disengages.

### 3. ROLLER BLOCK HEIGHT

#### ADJUSTMENT (Refer to Fig. 8)

Use the U type adjusting washers for screws (a), (b), and (c) to adjust the roller block height: the distance between the tape guide center to the chassis board should be 43 mm.

**NOTE:** Steps 1 and 3 also apply to the right guide roller.



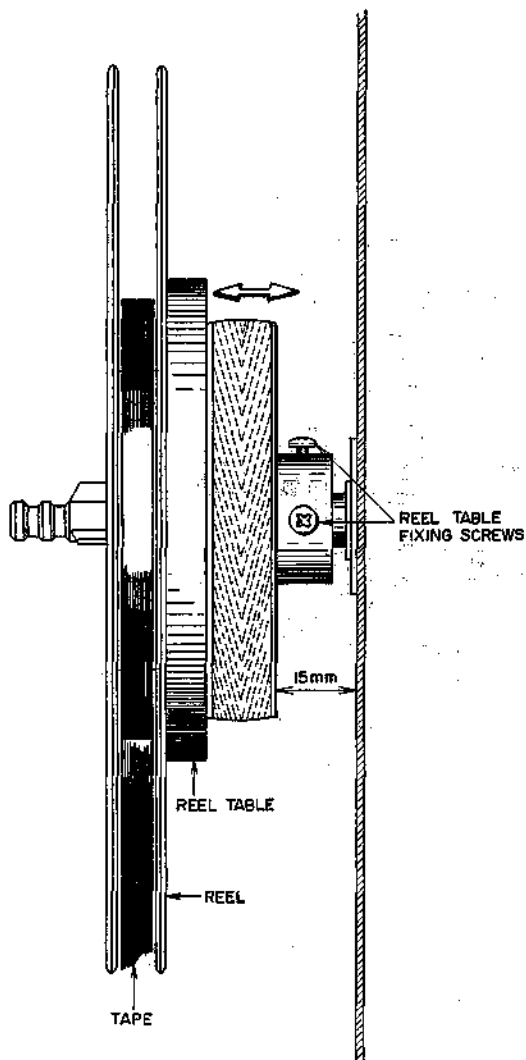

Fig. 9

#### 4. REEL TABLE HEIGHT ADJUSTMENT

(Refer to Fig. 9)

- 1) Temporarily screw in the fixing screws leaving a gap of 15 mm between the reel table and the chassis board.
- 2) Run the tape and adjust the height of the reel table so that the tape is taken up in the center of the reel. Tighten fixing screws.  
Adjust the height of the right reel table at fast forward, of the left reel table at rewind.

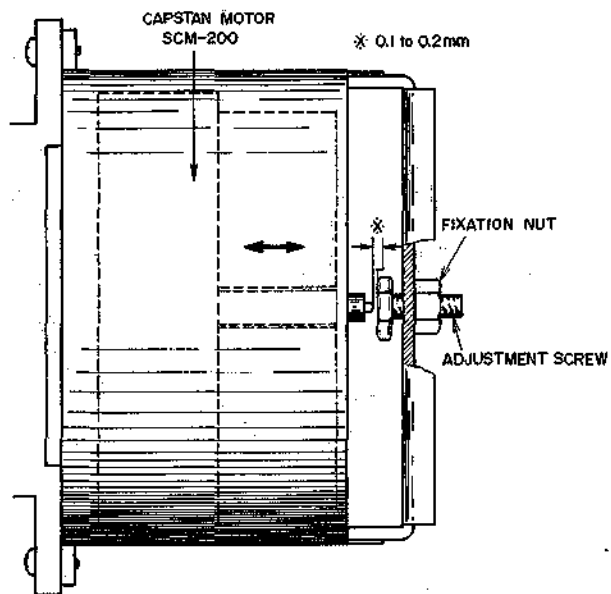

Fig. 10

#### 5. CAPSTAN SHAFT LOOSE PLAY

ADJUSTMENT (Refer to Fig. 10)

Adjust by turning Adjustment Screw to obtain a 0.1 to 0.2 mm degree of loose play when the capstan shaft is moved as indicated by the arrow mark. Tighten fixation nut to maintain optimum adjusted condition.

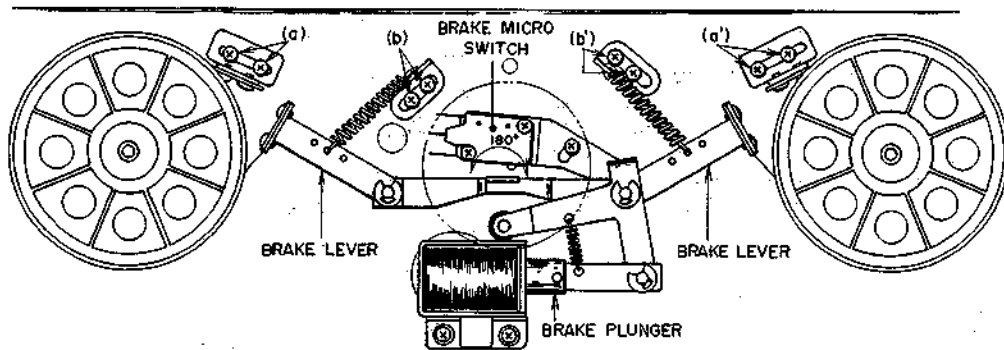

Fig. 11

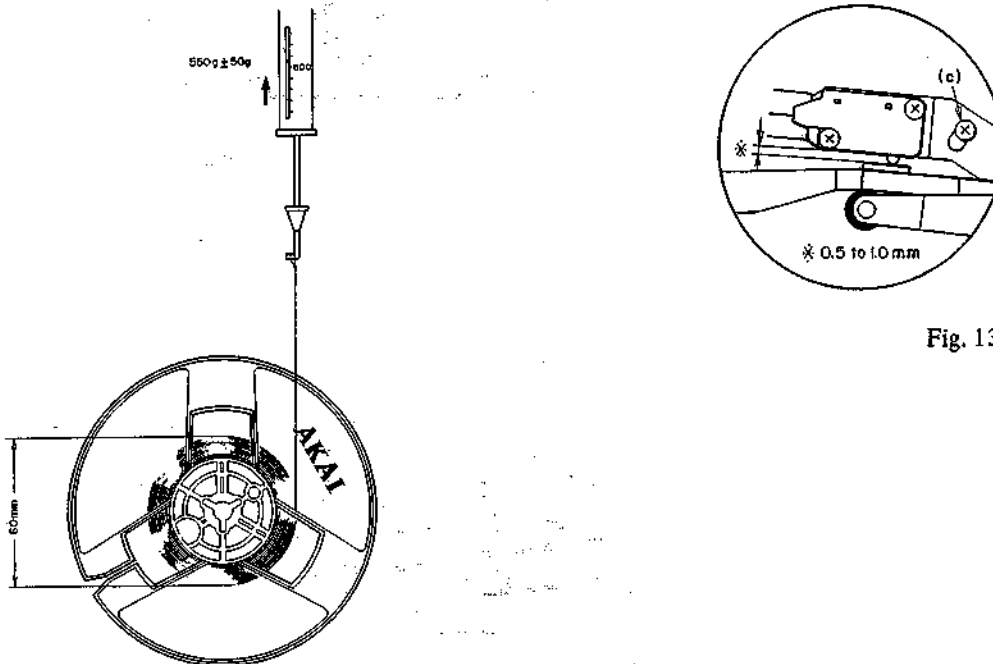

Fig. 12

Fig. 13

## 6. BRAKE BAND POSITION ADJUSTMENT AND BRAKE TENSION ADJUSTMENT

(Refer to Figs. 11 to 13)

- 1) Adjust the brake lever to 180° position by loosening the screws (a) and (a').
- 2) Work the brake plunger to check that the brake band is not slanted.
- 3) Adjust the position of the part with screws (b) and (b') to obtain a brake tension of  $550 \pm 50g$  on both brakes at stop mode.  
(Use a 1000g spring gauge for a reel with 60 mm diameter of tape.)

In case the specified brake tension cannot be obtained, connect the springs to the other holes on the brake lever and adjust.

- 4) By working the brake plunger with a finger, adjust the position of the microswitch screw (c) so that the gap between the brake lever and the microswitch body is 0.5 to 1.0 mm.

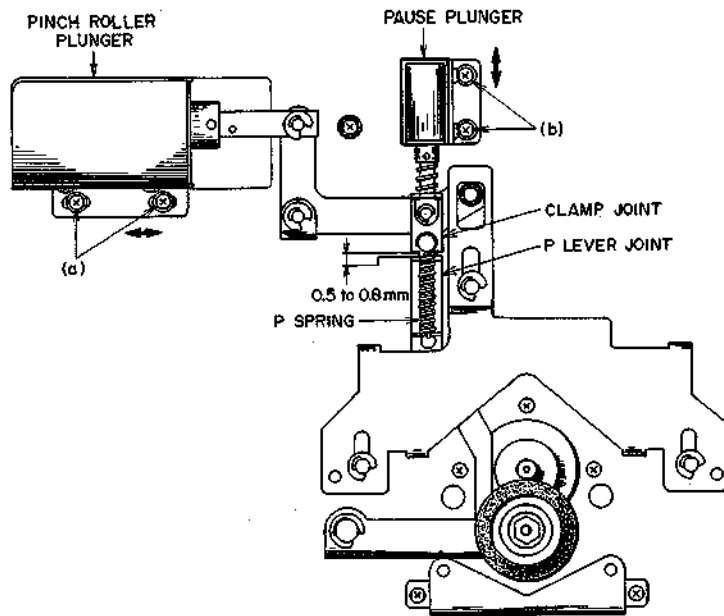

Fig. 14

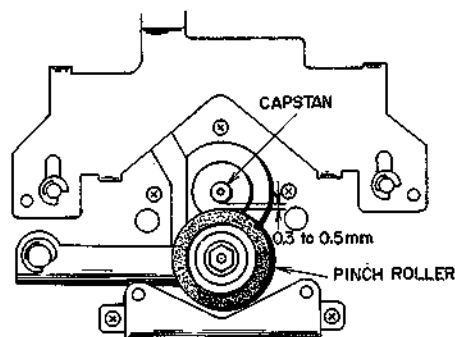

Fig. 15

## 7. PINCH ROLLER POSITION

### ADJUSTMENT (Refer to Fig. 14)

At the play mode, the gap between the clamp joint and the P lever joint should be 0.5 to 0.8 mm. Adjust the pinch roller plunger position with screws (a).

## 8. PAUSE PLUNGER POSITION

### ADJUSTMENT (Refer to Figs. 14, 15)

At the pause mode, the gap between the capstan and the pinch roller should be 0.3 to 0.5 mm. Adjust the pause plunger position with screws (b).

## 9. PINCH ROLLER PRESSURE

### ADJUSTMENT

Connect a 2 kg spring gauge to the pinch roller fixing screws. Pull down the pinch roller and then let it slowly move back. Check that the spring gauge reads  $1.2 \text{ kg} \pm 200\text{g}$  at the moment the pinch roller touches the capstan and starts rolling. If it reads otherwise, replace the P spring (See Fig. 14).

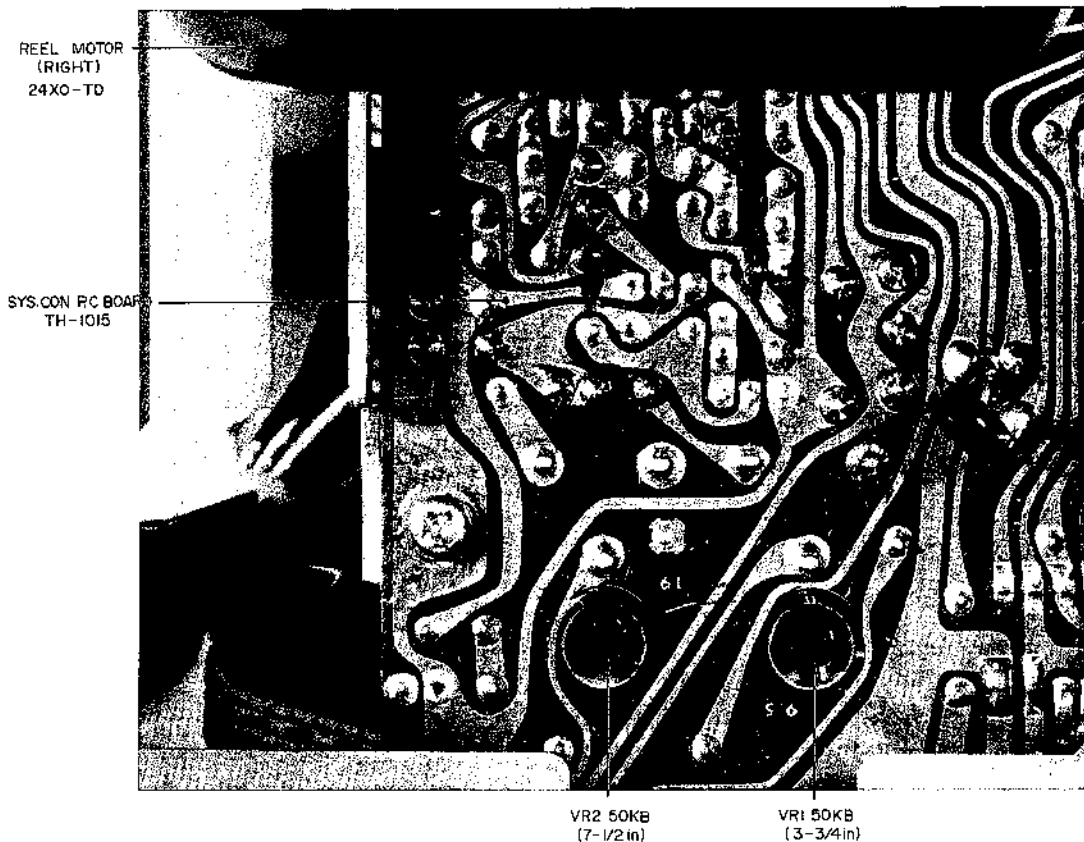

Fig. 16

## 10. TAPE SPEED ADJUSTMENT

(Refer to Fig. 16)

Set the Tape Speed Switch to 7-1/2 ips and playback the 1,000 Hz, 7-1/2 Test tape.

Connect a frequency counter to LINE OUT and adjust VR2 50 kB until the counter reads 1,000 Hz  $\pm 0.5\%$ .

Next, set the Tape Speed Switch to 3-3/4 ips and adjust VR1 50 kB until the frequency counter reads 500 Hz  $\pm 0.5\%$ .

# VII. HEAD ADJUSTMENT

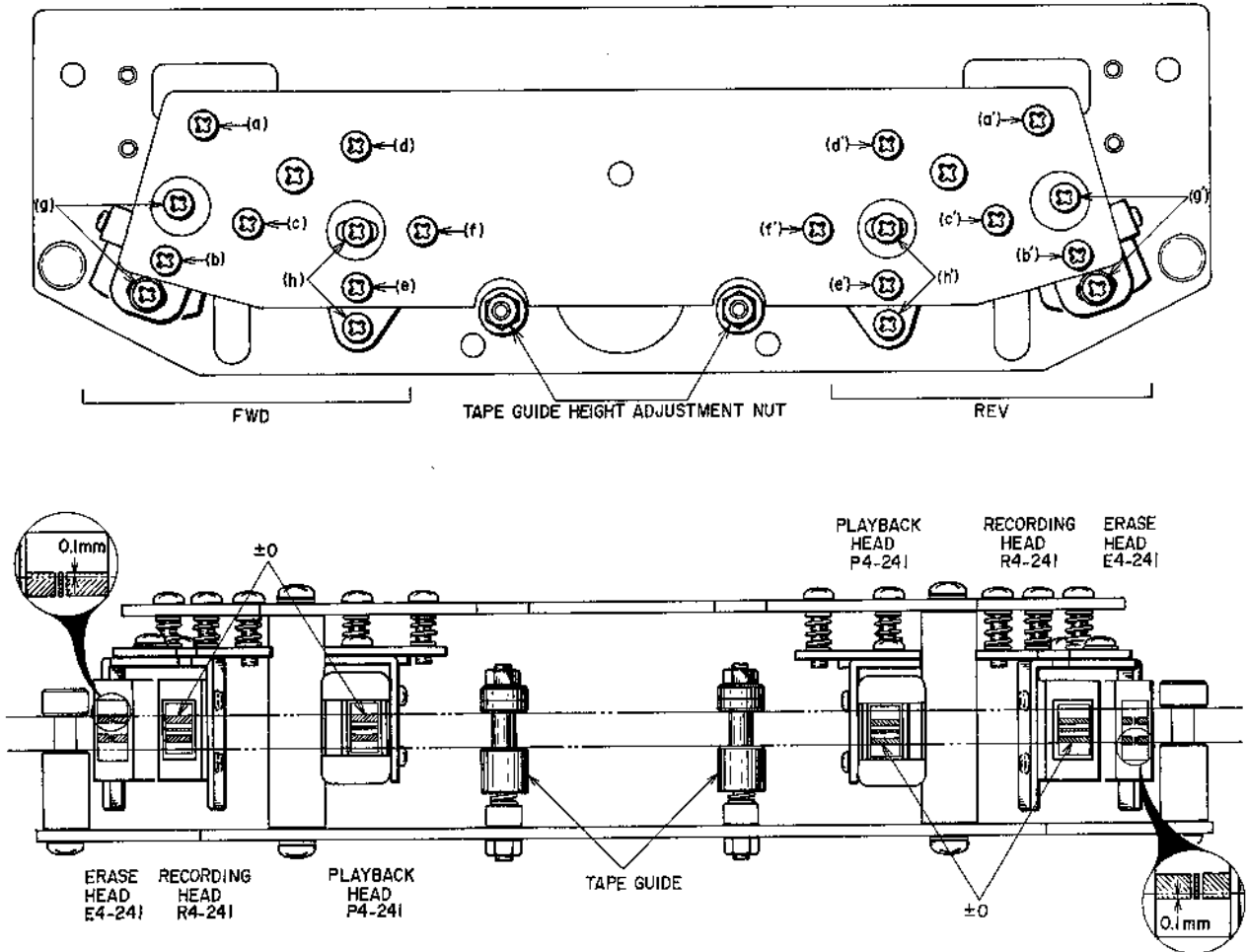

Fig. 17

Step	Adjustment Item	Test Tape Supply Signal	Mode	Adjustment Point	Remarks
1	Tape Guide Height	Optional	FWD	Tape Guide Height Adjustment Nut	1) Adjust so that tape travels smoothly and does not twist. 2) Do not thread tape over tension arm.
2	FWD Recording Head Height	Optional	FWD	(a) (b) (c)	Upper edges of Left Ch. head core and tape are the same height.
3	FWD Erase Head Height Confirmation	Optional	FWD		Upper edge of Left Ch. head core is 0.1 mm higher than upper edge of tape.
4	FWD Playback Head Height	Optional	FWD	(d) (e) (f)	Upper edges of Left Ch. head core and tape are the same height.
5	FWD Playback Head Azimuth Alignment	8,000 Hz 3-3/4 ips Test Tape	FWD	(f)	Maximum output, both channels.
6	FWD Playback Head Angle Alignment	8,000 Hz 3-3/4 ips Test Tape	FWD	(h)	Adjust head gap surface so that there is no change in output level when tension is applied to the supply reel side.
7	FWD Recording Head Azimuth Alignment	Scotch #211 Tape 15,000 Hz -20 dBm	REC	(c)	Maximum output, both channels.
8	FWD Recording Head Angle Alignment	Scotch #211 Tape 15,000 Hz -20 dBm	REC	(g)	Adjust head gap surface so that there is no change in output level when tension is applied to the supply reel side.

Chart-4

- NOTES:**
1. As perfect head adjustments are vital to tape deck performance, be sure that these adjustments are carried out properly.
  2. Be careful not to use a magnetized driver or other magnetized tools in the vicinity of the heads.
  3. Use only new tape as level variation is likely to occur when using old tape.
  4. Demagnetize heads with head demagnetizer before and after head adjustment.
  5. Set tape speed to 7-1/2 ips.
  6. Adjustments outlined in Chart 4 are only for FWD side heads. However, adjustments for REV side heads are exactly the same.

## VIII. AMPLIFIER ADJUSTMENT

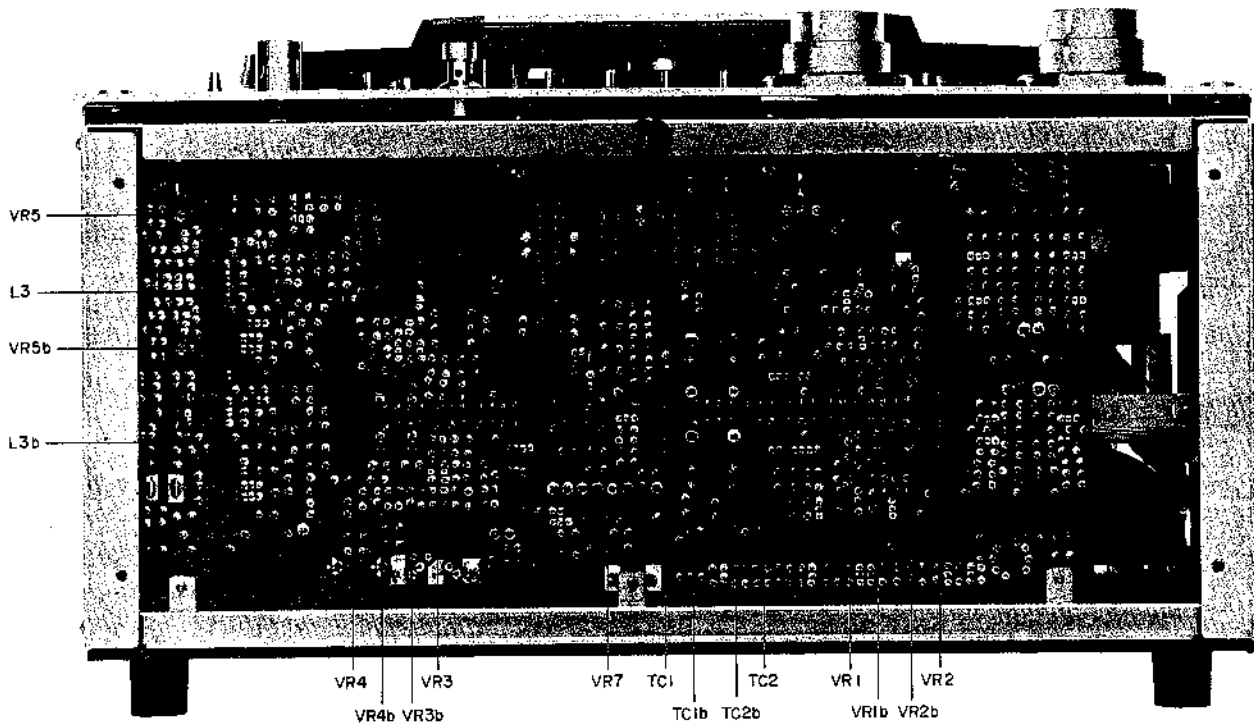

Fig. 18

VR3	50 kB	FWD Playback Level Adjustment
VR4	50 kB	REV Playback Level Adjustment
VR5	1 kB	VU Meter Sensitivity Adjustment
VR2	10 kB	FWD Recording Level Adjustment
VR1	10 kB	REV Recording Level Adjustment
TC2	80 PF	FWD Frequency Response Adjustment (3-3/4 in)
TC1	80 PF	REV Frequency Response Adjustment (3-3/4 in)
VR7	30 kB	Frequency Response Adjustment (7-1/2 in)
L3		Bias Filter Adjustment

\* The letter "b" following an adjustment part number indicates "RIGHT CHANNEL".

Step	Adjustment Item	Test Tape Supply Signal	Mode	Adjustment Point	Result	Remarks
1	FWD Playback Level	700Hz 7-1/2 ips 0VU Test Tape	FWD	VR3 50 kB	0±0.5dBm (0.775V)	
2	REV Playback Level	700Hz 7-1/2 ips 0VU Test Tape	REV	VR4 50 kB	0±0.5dBm (0.775V)	
3	VU Meter Sensitivity	700Hz 7-1/2 ips 0VU Test Tape	FWD	VR5 1 kB	0 VU indication	
4	FWD Recording Level	Scotch #211 Tape 1,000 Hz 0 dBm Recording	FWD-REC	VR2 10 kB	0±0.5dBm (0.775V)	
5	REV Recording Level	Scotch #211 Tape 1,000 Hz 0 dBm Recording	REV-REC	VR1 10 kB	0±0.5dBm (0.775V)	
6	FWD Frequency Response (3-3/4 ips)	Scotch #211 Tape 1.5kHz, 15kHz -20dBm Recording	FWD-REC	TC2	1.5 kHz, 15 kHz flat	Tape Speed 3-3/4 ips. Recheck Recording Level.
7	REV Frequency Response (3-3/4 ips)	Scotch #211 Tape 1.5kHz, 15kHz -20dBm Recording	REV-REC	TC1	1.5 kHz, 15 kHz flat	Tape Speed 3-3/4 ips. Recheck Recording Level.
8	Frequency Response (7-1/2 ips)	Scotch #211 Tape 1.5kHz, 15kHz -20dBm Recording	FWD-REC	VR7 30 kB	1.5 kHz, 15 kHz flat	Tape Speed 7-1/2 ips. Recheck Recording Level.
9	FWD Distortion Confirmation	Scotch #211 Tape 1,000Hz 0 dBm Recording	FWD-REC		Less than 0.5%	See NOTE 4
10	REV Distortion Confirmation	Scotch #211 Tape 1,000 Hz, 0 dBm Recording	REV-REC		Less than 0.5%	See NOTE 4
11	Bias Filter		REC	L3	Less than -30 dB	Mic, Line Volume at Max. See NOTE 5.

Chart-5

- NOTES:**
1. Output Level Control should be at maximum.
  2. Except for Steps 6 and 7, set Tape Speed to 7-1/2 ips.
  3. Set Tape Selector Switch to Low Noise position.
  4. If it does not comply with the specifications, repeat Steps 6 and 7, and re-adjust.
  5. Unless the core is moved intentionally this adjustment is not necessary.



## IX. DC RESISTANCE OF VARIOUS COILS

Part	Designation	DC Resistance
Main Motor	SCM-200	Between BLU-RED: 110 ohms Between YLW-BRN: 170 ohms Pick-up Coil: 665 ohms
Reel Motor	24X0-TD	Between BLU-RED: 30 ohms Between YLW-BRN: 157 ohms
Pinch Roller Plunger	1664TLT	700 ohms $\pm 10\%$
Brake Plunger, REV Plunger	1240TLT	600 ohms $\pm 10\%$
Pause Plunger	TDS-07A	600 ohms $\pm 10\%$
Relay	FRL-264	650 ohms $\pm 15\%$
Relay	BR211	1,280 ohms $\pm 10\%$
Relay	LAB2NS	1,750 ohms $\pm 10\%$
Erase Head	E4-241	2.1 ohms
Recording Head	R4-241	5.9 ohms
Playback Head	P4-241	219 ohms

Chart-6

## X. CLASSIFICATION OF VARIOUS P.C BOARDS

### 1. P.C BOARD TITLES AND IDENTIFICATION NUMBERS

P.C Board Title	P.C Board Number
Sys. Con P.C Board	TH-1015
Pre Amp P.C Board	TH-5001A
Rec LED P.C Board	TH-5001B
Volume P.C Board	TH-5002
Fuse P.C Board	TH-2040
Operation P.C Board (A)	TH-2041
Operation P.C Board (B)	TH-2042
Direction P.C Board	TH-2043
Reverse P.C Board	TH-2044
Sensing P.C Board	TH-2045
Rec Mute P.C Board	TH-2046

Chart-7

## 2. COMPOSITION OF VARIOUS P.C BOARDS

- 1) SYS. CON P.C BOARD TH-1015 (4ED), REVERSE P.C BOARD TH-2044,  
SENSING P.C BOARD TH-2045 & REC MUTE P.C BOARD TH-2046

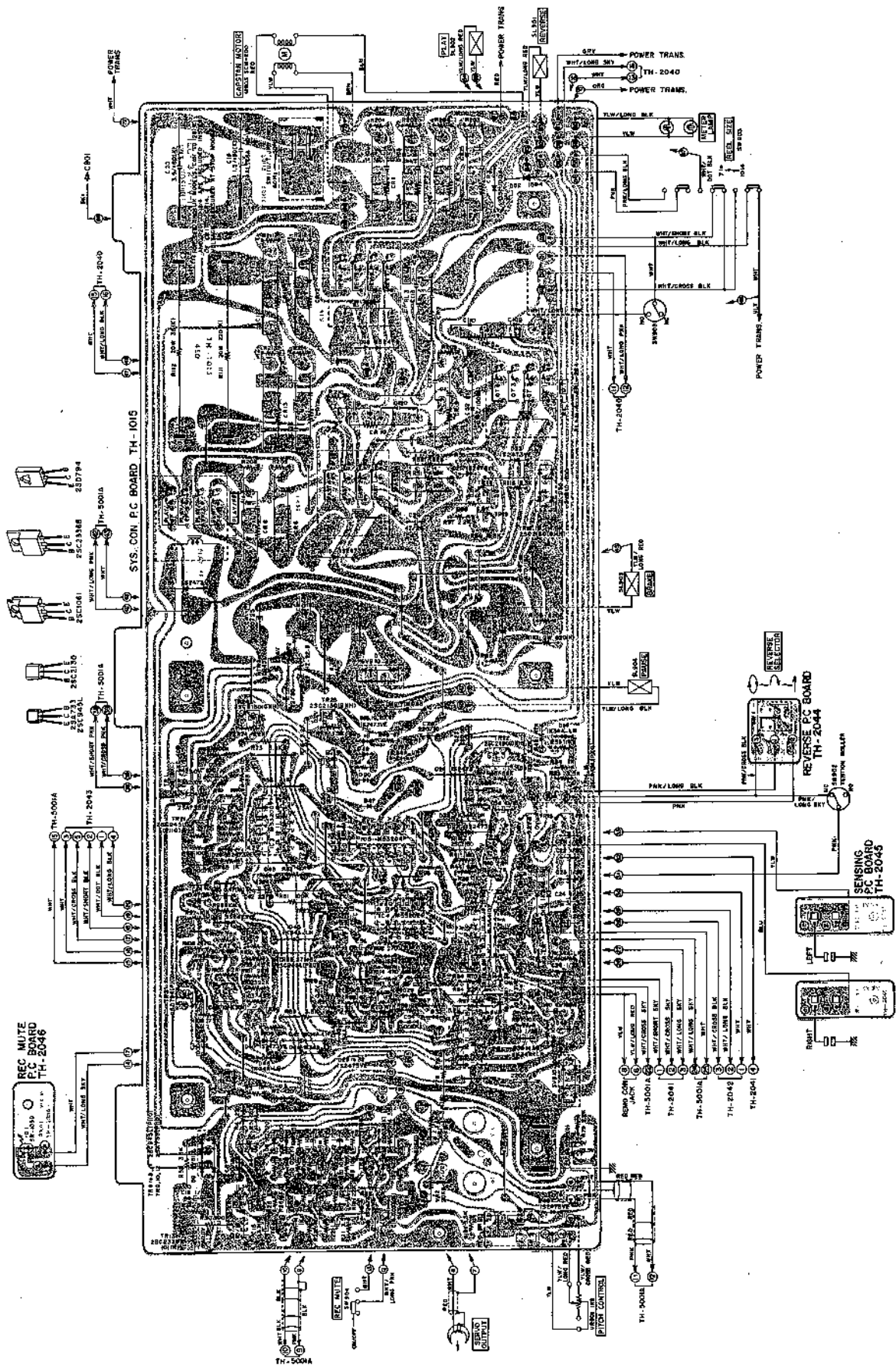

## 2) PRE AMP P.C BOARD TH-5001A (2ED) & REC LED P.C BOARD TH-5001B

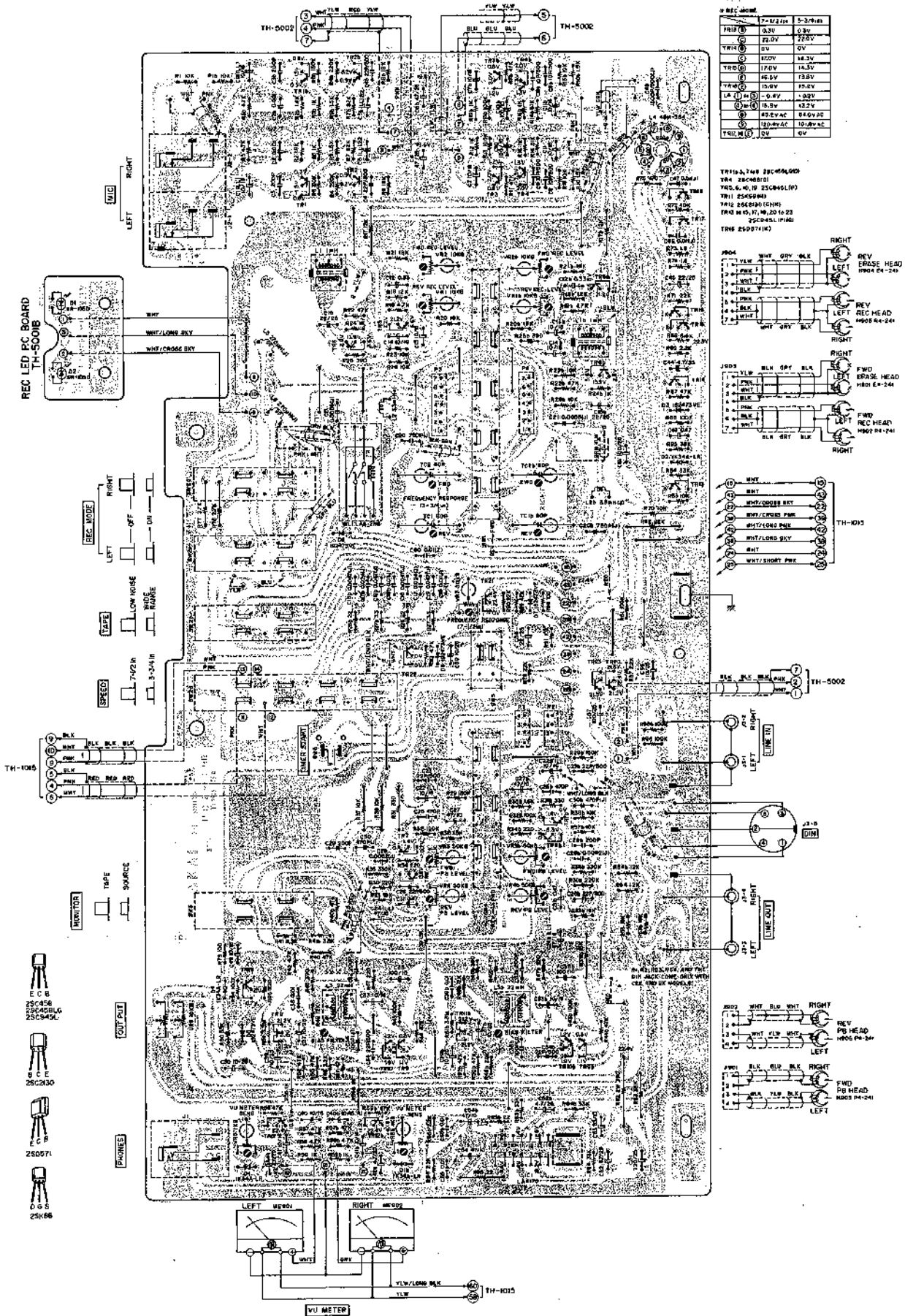

3) VOLUME P.C BOARD TH-5002

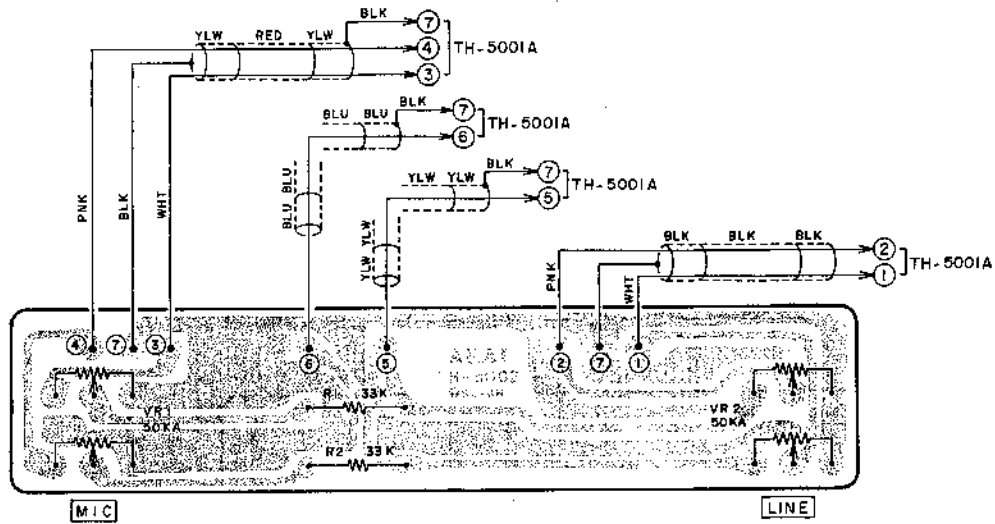

4) DIRECTION P.C BOARD TH-2043 (2ED)

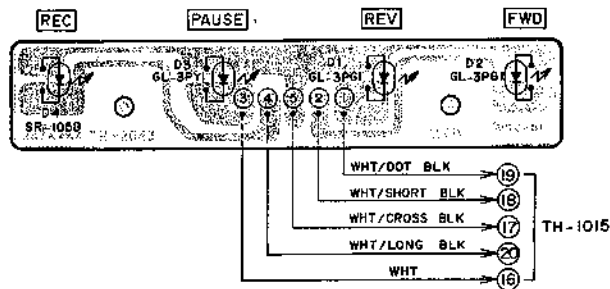

5) OPERATION P.C BOARD (A) TH-2041 (2ED) & OPERATION P.C BOARD (B) TH-2042 (2ED)

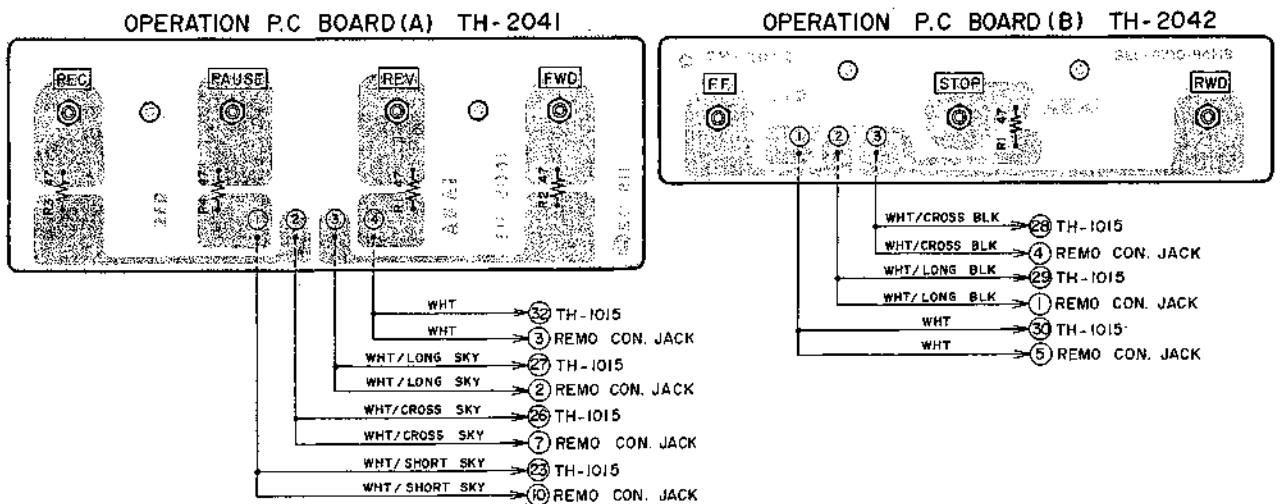

6) FUSE P.C BOARD TH-2040 (U/T)

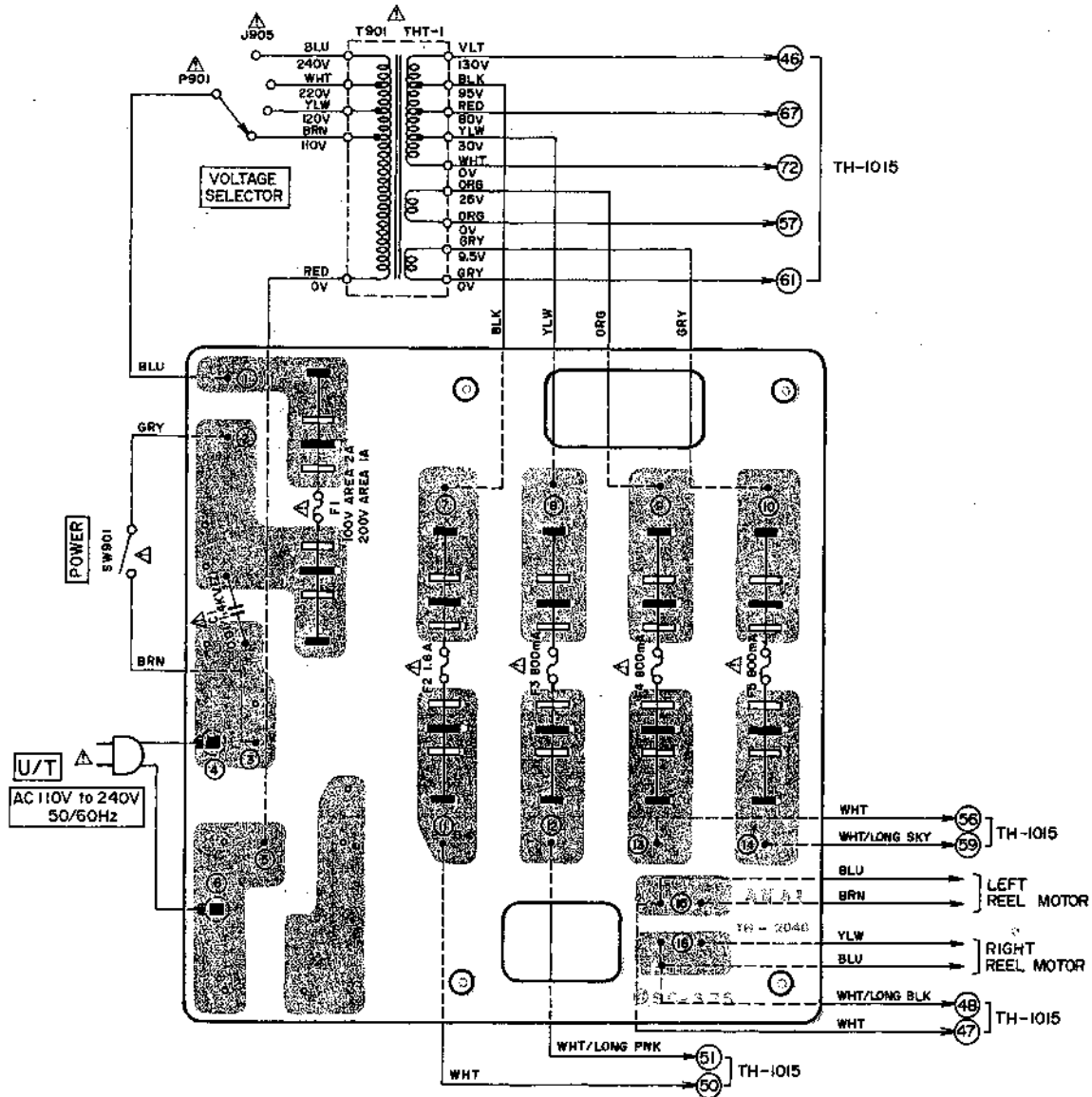

WARNING: Δ INDICATES SAFETY CRITICAL COMPONENTS. FOR CONTINUED SAFETY, REPLACE SAFETY CRITICAL COMPONENTS ONLY WITH MANUFACTURER'S RECOMMENDED PARTS.

AVERTISSEMENT: Δ IL INDIQUE LES COMPOSANTS CRITIQUES DE SÛRETÉ. POUR MAINTENIR LE DEGRÉ DE SÛRETÉ DE L'APPAREIL, NE REMPLACER LES COMPOSANTS DONT LE FONCTIONNEMENT EST CRITIQUE POUR LA SÛRETÉ QUE PAR DES PIÈCES RECOMMANDÉES PAR LE FABRICANT.

7) FUSE P.C BOARD TH-2040 (JPN, AAL, CSA)

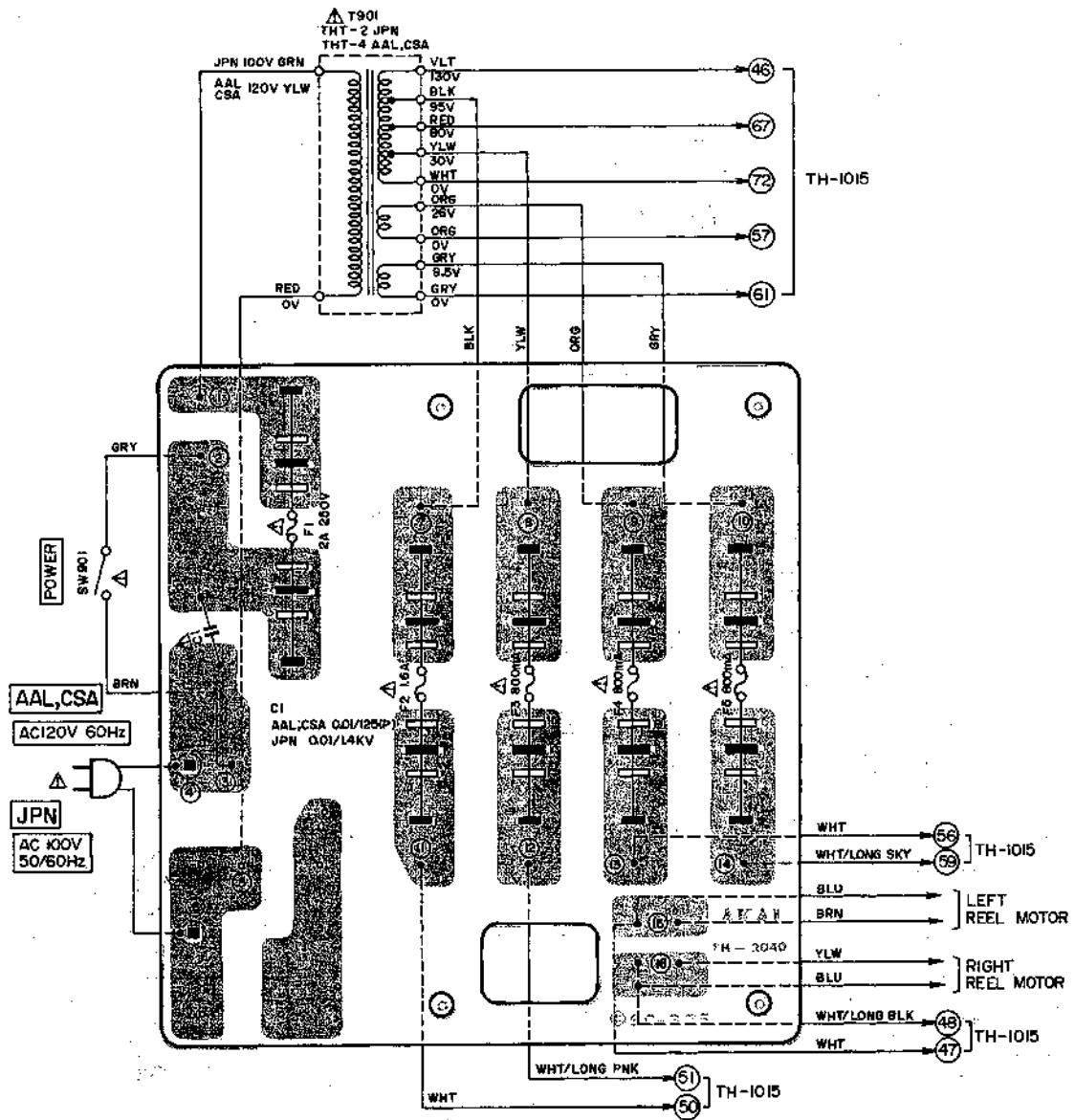

WARNING: Δ INDICATES SAFETY CRITICAL COMPONENTS. FOR CONTINUED SAFETY, REPLACE SAFETY CRITICAL COMPONENTS ONLY WITH MANUFACTURER'S RECOMMENDED PARTS.  
 AVERTISSEMENT: Δ IL INDIQUE LES COMPOSANTS CRITIQUES DE SÛRETÉ. POUR MAINTENIR LE DEGRÉ DE SÛRETÉ DE L'APPAREIL, NE REMPLACER LES COMPOSANTS DONT LE FONCTIONNEMENT EST CRITIQUE POUR LA SÛRETÉ QUE PAR DES PIÈCES RECOMMANDÉES PAR LE FABRICANT.

8) FUSE P.C BOARD TH-2040, (CEE, UK)

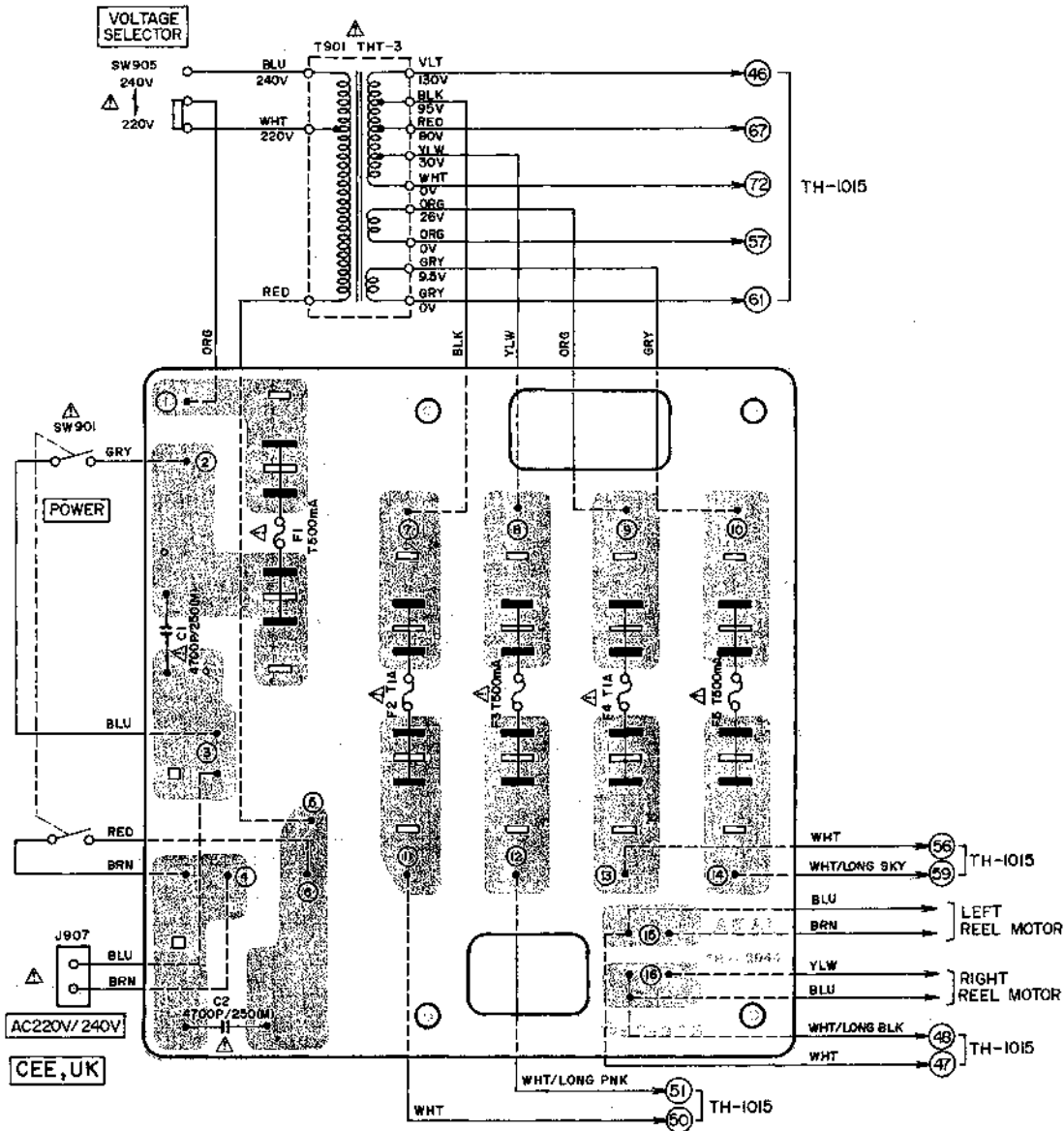

WARNING: Δ INDICATES SAFETY CRITICAL COMPONENTS. FOR CONTINUED SAFETY, REPLACE SAFETY CRITICAL COMPONENTS ONLY WITH MANUFACTURER'S RECOMMENDED PARTS.  
 AVERTISSEMENT: Δ IL INDIQUE LES COMPOSANTS CRITIQUES DE SÛRETÉ. POUR MAINTENIR LE DEGRÉ DE SÛRETÉ DE L'APPAREIL, NE REMPLACER LES COMPOSANTS QU'AVEC LE FONCTIONNEMENT EST CRITIQUE PAR LA SÛRETÉ QUE PAR DES PIÈCES RECOMMANDÉES PAR LE FABRICANT.

MEMO

---



MEMO

---

MEMO

---

MEMO

---

---

SECTION 2

**PARTS LIST**

TABLE OF CONTENTS

1. RECOMMENDED SPARE PARTS LIST . . . . .	46
2. HEAD BLOCK . . . . .	48
3. MOTOR (SCM-200) BLOCK . . . . .	50
4. REEL TABLE BLOCK . . . . .	51
5. ROLLER BLOCK . . . . .	52
6. POWER SUPPLY BLOCK . . . . .	54
7. MECHA ASSEMBLY BLOCK . . . . .	56
8. P.C BOARDS . . . . .	58
(1) SYS. CON P.C BOARD (TH-1015) BLOCK . . . . .	58
(2) PRE AMP P.C BOARD (TH-5001A) BLOCK . . . . .	59
(3) VOL. P.C BOARD (TH-5002) BLOCK . . . . .	59
(4) REC, LED P.C BOARD (TH-5001B) BLOCK . . . . .	59
9. AMP ASSEMBLY BLOCK . . . . .	60
10. FINAL ASSEMBLY BLOCK . . . . .	62
11. LIST OF INTERCHANGEABLE SEMICONDUCTORS . . . . .	64
INDEX . . . . .	65

Resistor and Capacitor which is not listed in this parts list, please refer to COMMON LIST FOR SERVICE PARTS.

## HOW TO USE THIS PARTS LIST

1. This parts list is compiled by various individual blocks based on assembly process.
2. When ordering parts, please describe parts number, serial number, and model number in detail.
3. How to read List

The reference number corresponds with illustration or photo number of that particular parts list.

This number corresponds with the Figure Number.

This number corresponds with the individual parts index number in that figure.

A small "x" indicates the inability to show that particular part in the Photo or Illustration.

Schematic Diagram Number of individual manufactured part.  
(not required for parts order)

Ref. No.	Parts No.	Description	Schematic No.
<b>FLYWHEEL BLOCK #13</b>			
12-115x	800425	Flywheel Block Assy. Comp.	RDG #13
12-116	244506	Flywheel Only	RD-233
12-117x	244754	Felt, Flywheel	RD-275
12-118	251324	Main Metal Case	RD-236
12-119	253080	Main Metal	RD-237

4. The symbol numbers shown on the P.C. Board list can be matched with the Composite Views of Components of the Schematic Diagram or Service Manual.
5. Please utilize separate "Common List for Service Parts" for Resistor Parts orders.
6. The shape of the parts and parts name, etc. can be confirmed by comparing them with the parts shown, on the Electrical Parts Table of P.C. Board.
7. Both the kind of part and installation position can be determined by the Parts Number. To determine where a parts number is listed, utilize Parts Index at end of Parts List.  
It is necessary first of all to find the Parts Number. This can be accomplished by using the Reference Number, listed at right of parts number in the Parts Index. (meaning of ref. no. outlined in Item 3 above).
8. Utilize separate "Price List for Parts" to determine unit price. The most simple method of finding parts Price is to utilize the reference number.

- CAUTION:**
1. When placing an order for parts, be sure to list the parts no., model no., and description. There are instances in which if any of this information is omitted, parts cannot be shipped or the wrong parts will be delivered.
  2. Please be careful not to make a mistake in the parts no. If the parts no. is in error, a part different from the one ordered may be delivered.
  3. Because parts number and parts unit supply in the Preliminary Service Manual (Basic Parts List) may be partially changed, please use this parts list for all future reference.

**WARNING:** ⚠ INDICATES SAFETY CRITICAL COMPONENTS. FOR CONTINUED SAFETY, REPLACE SAFETY CRITICAL COMPONENTS ONLY WITH MANUFACTURER'S RECOMMENDED PARTS.

**AVERTISSEMENT:** ⚠ IL INDIQU LES COMPOSANTS CRITIQUES DE SURETE. POUR MAINTENIR LE DEGRE DE SECURITE DE L'APPAREIL NE REMPLACER LES COMPOSANTS DONT LE FONCTIONNEMENT EST CRITIQUE POUR LA SECURITE QUE PAR DES PIECES RECOMMANDEES PAR LE FABRICANT.

## AC INLET SYSTEM

This model is equipped with an AC INLET SYSTEM. Please refer to the AC INLET SYSTEM CHART below for the specific type. By the AC INLET SYSTEM, AC (mains) cord can be connected to and disconnected from the model because the model is provided with socket exclusively for AC (mains) cord on its main body. Please note, however, that certain models are not equipped with this system and has a built-in AC (mains) cord as before.

### AC INLET SYSTEM CHART

#### CLASS I

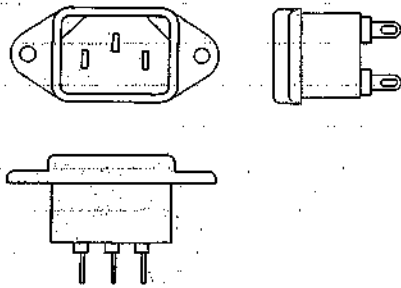

Picture 1  
AC INLET  
to be  
installed  
on machines

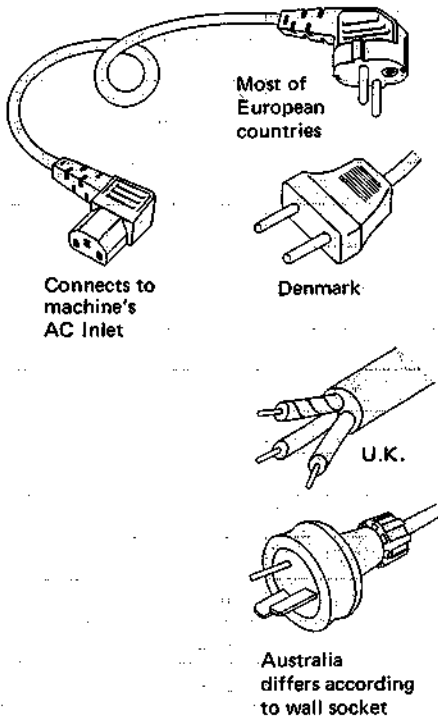

Picture 2  
AC (mains)  
cord

#### CLASS II

☐ This mark indicating double insulation will be attached to machine's rear panel

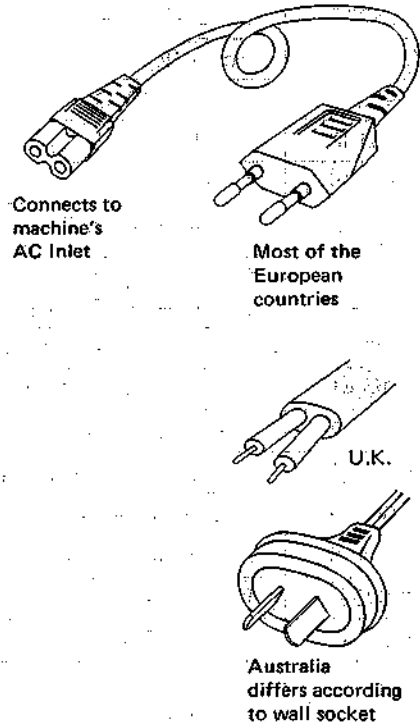
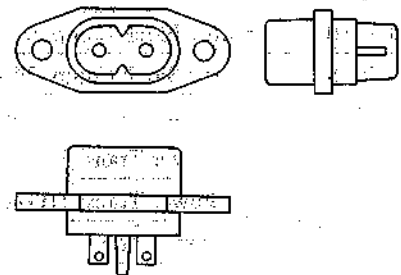

#### Parts List for AC (mains) Cord Set

Standard		Description	Type of AC Inlet	Parts No.
Class I	CEE	Cord Set CEE (3 cores)	3P	EW302993
	BEAB	Cord Set BEAB (3 cores)	3P	EW302994
	SAA	Cord Set SAA (3 cores)	3P	EW302996
	U/T	Cord Set U/T (3 cores)	3P	EW302646
Class II	CEE	Cord Set CEE (2 cores)	2P	EW638144
	BEAB	Cord Set BEAB (2 cores)	2P	EW302995
	SAA	Cord Set SAA (2 cores)	2P	EW302991
	U/T	Cord Set U/T (2 cores)	2P	EW302899

## 1. RECOMMENDED SPARE PARTS LIST

Because, if the parts listed below are on hand, almost any repair can be accomplished, we suggest that you stock these Recommended Spare Parts Items.

Parts No.	Description	Note
BA308262	Sys. Con P.C Board Comp. GX-635D (U/T) (JPN)	
BA308263	Sys. Con P.C Board Comp. GX-635D (CSA) (AAL)	
BA308264	Sys. Con P.C Board Comp. GX-635D (CEE) (UK)	
BA308275	Pre Amp P.C Board Comp. GX-635D (U/T) (JPN, CSA, AAL)	
BA308296	Pre Amp P.C Board Comp. GX-635D (CEE) (UK)	
BH308277	Head Block Comp. GX-635D	
BM308310	Motor Block Comp. (SCM-200) GX-635D	
BM587518	Motor Block Comp. 24XO-TD TE	
BR587553	Reel Table Block Comp. TE (Take-up)	
BT308918	△ Power Trans. THT-1	U/T
BT308919	△ Power Trans. THT-2	JPN
BT308921	△ Power Trans. THT-4	CSA, AAL
BT308920	△ Power Trans. THT-3	CEE, UK
BZ308227	Roller (L) Block Comp. GX-635D	
BZ308228	Roller (R) Block Comp. GX-635D	
ED698826	LED SR-105D	
ED283138	LED GL-3PG1	
ED303005	LED GL-3PY1	
ED308945	Silicon Diode SVB10-100	
ED313623	Zener Diode HZ22-3	
ED309069	Zener Diode HZ6B-2	
ED308951	Zener Diode WZ-120	
ED308941	Silicon Diode SVB10-200	
ED308952	Germanium Diode (Stop. Type) 1K34A-LR	
ED308953	Germanium Diode (Home. Type) 1K34A-LH	
ED306109	Silicon Diode W03B	
ED224550	Silicon Diode 10D4	
EI308936	IC M54410P	IC1
EI430661	IC M53200P	IC2, 3
EI633960	IC M53202P	IC4
EI573840	IC M53204P	IC5
EI306141	IC LA4170	IC1
EM309051	VU Meter VU-50-003	U/T, CSA, AAL, CEE, UK
EM309050	VU Meter VU-50-005	JPN
EP309056	Plunger TDS-07A	
EP310448	Plunger 1664TLT	
EP310447	Plunger 1240TLT	
EP309061	Relay FRL-264	
EP308949	Relay BR211	
EP308973	Relay LAB2NS	

Parts No.	Description	Note
ES313792	△ Slide SW. TSS012183	CBE, UK
ES308914	Push SW. SUF12	
ES308913	Rotary SW. SRU1023S	
ES308925	Push SW. SUF12	
ES313622	△ Push SW. JP-27 (w/o level)	U/T, JPN
ES309059	△ Push SW. JP-27	CSA, AAL
ES309058	△ Push SW. JP-24	CBE, UK
ES309094	Slide SW. SL13-6-6-2-2-B	
ES301435	Slide SW. CL-210E	
ES308984	Push SW. SUF44	
ES308983	Push SW. J-K2023	
ES301436	Slide SW. CL-206E	
ES301715	Slide SW. SSB02214	
ES306292	Leaf SW. BSW-86	
ET312497	Transistor 2SC1061 (B) (C) YC-408	
ET307349	Transistor 2SD794 (P) (Q)	
ET308947	Transistor 2SC2336B (Q) (R)	
ET308937	Transistor 2SC2130 (G) (H)	
ET522268	Transistor 2SA7339 (Q)	
ET399846	Transistor 2SC945L (Q)	
ET352146	Transistor 2SC458LG (D)	
ET308978	FET 2SK68 (M)	
ET311336	Transistor 2SC2130 (H)	
EV308917	Vol. VM10E 1 kB	
EV302718	Semi-fixed/Vol. V18K3-6 (4US) 50 kB	
EV309071	Semi-fixed/Vol. V18K3-6 (4US) 20 kB	
EV305637	Semi-fixed/Vol. D8 Axial Type 10 kB	
EV305636	Semi-fixed/Vol. D8 Axial Type 50 kB	
EV306989	Semi-fixed/Vol. D8 Axial Type 1 kB	
EV301437	Single Axial 2 Throw Vol. GM70R-715 10 kB×2	
EV308966	Semi-fixed/Vol. D8 Axial Type 30 kB	
EV308995	Double Axial 2 Throw Vol. DM20R 50 kA×2	
HE308149	ERASE HEAD E4-241	
HP308146	PB HEAD P4-241	
HR308148	REC HEAD R4-241	
MB308701	Counter Belt	
MP424023	Pinch Roller KD D=37	



## 2. ILLUSTRATION OF HEAD BLOCK

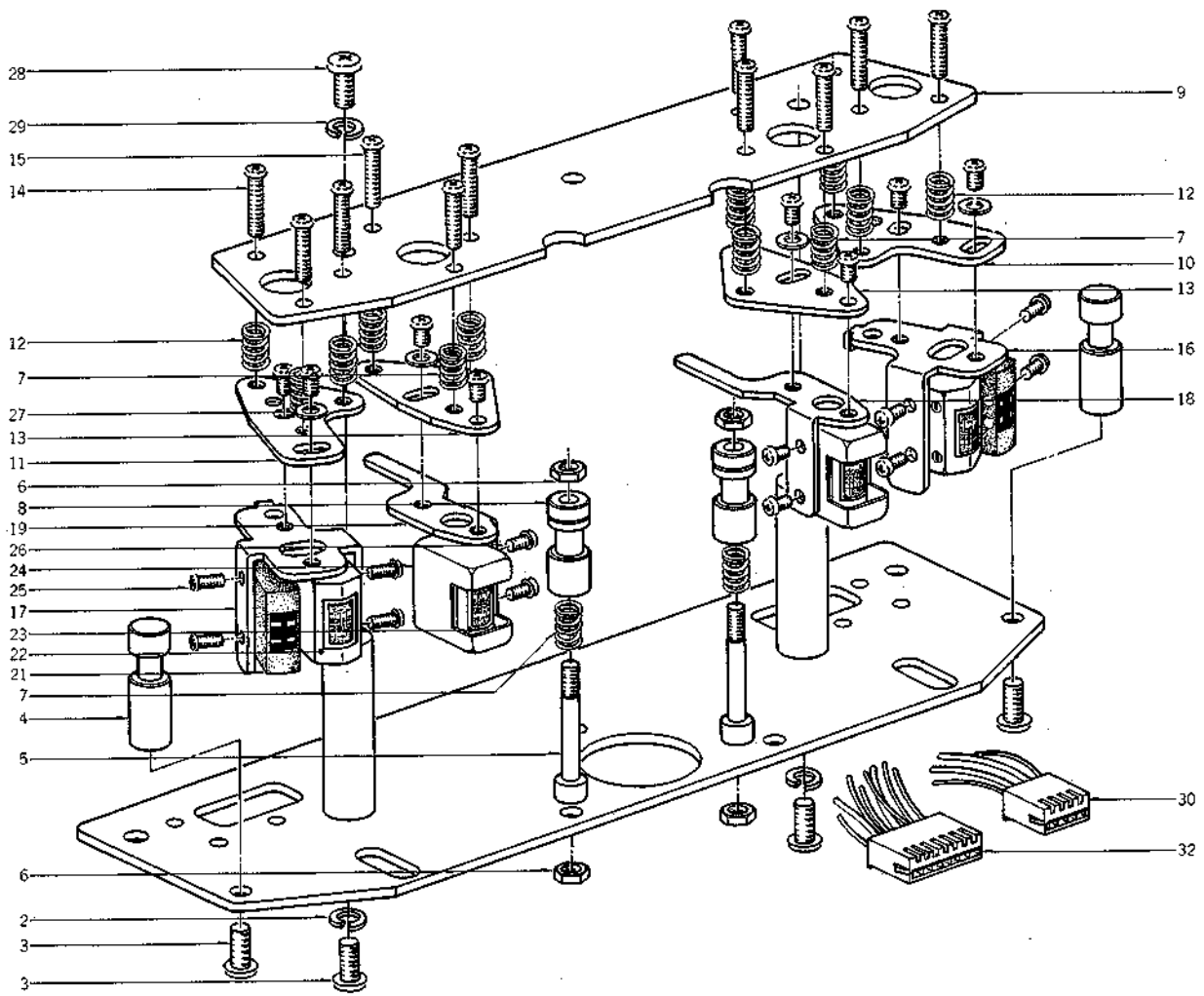

## 2) HEAD BLOCK

Ref. No.	Parts No.	Description	Schematic No.
2-1x	BH308277	Head Block Comp. GX-635D	
2-2	ZW273914	Spring Washer, M4	
2-3	ZS413201	Screw, pan head 4x8	
2-4	HZ528581	Tape Guide (A)	ND-0006
2-5	MH578957	Tape Guide Prop	TD-0003
2-6	ZW265522	M3 Nut, #2	
2-7	ZG466312	Angle Adjust Spring (E)	BS-0018
2-8	HZ301777	Tape Guide (C)	NE-0212
2-9	HB308681	Head Sub Chassis	TH-0002
2-10	HB309407	ER Head Base (A)	TH-0007
2-11	HB309408	ER Head Base (B)	TH-0007
2-12	ZG303300	Angle Adjust Spring (B)	RD-55
2-13	HB308685	PB Head Base	TH-0005
2-14	ZS608501	Screw, pan head 3x12	
2-15	ZS417407	Screw, pan head 3x10	
2-16	HA309409	ER Head Angle (A)	TH-0008
2-17	HA309410	ER Head Angle (B)	TH-0008
2-18	HA308686	PB Head Angle (A)	TH-0006
2-19	HA308687	PB Head Angle (B)	TH-0006
2-20x	HZ309411	P.C Board Terminal Plate	TH-0009
2-21	HE308149	ERASE HEAD E4-241	
2-22	HR308148	REC HEAD R4-241	
2-23	HP308146	PB HEAD P4-241	
2-24	HZ301366	Head Shield	NE-0211
2-25	ZS460440	Screw, pan head 2x4	
2-26	ZS608095	Screw, pan head 2x5	
2-27	ZW309055	Washer D3x6x0.5t (Black)	
2-28	ZS201778	Screw, pan head 4x8	
2-29	ZW668621	M4 Spring Washer (Black)	
2-30	EJ310390	4P Micro Connector	
		W-H8004-020	26-6-306
2-31x	EJ310391	4P Micro Connector	
		W-H8004-021	26-6-307
2-32	EJ310392	7P Micro Connector	
		W-H8004-016	26-6-308
2-33x	EJ310446	7P Micro Connector	
		W-H8004-017	26-6-309

### 3. ILLUSTRATION OF MOTOR (SCM-200) BLOCK

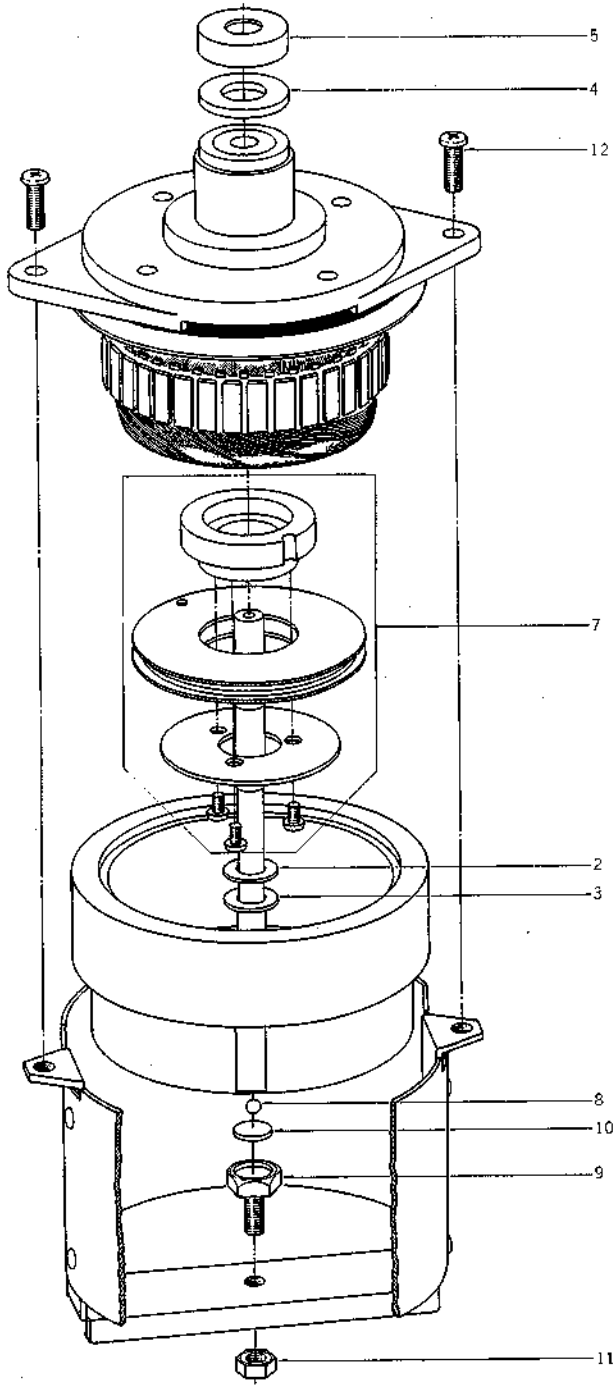

### 3) MOTOR (SCM-200) BLOCK

Ref. No.	Parts No.	Description	Schematic No.
3-1x	BM308310	Motor Block Comp. (SCM-200) GX-635D	
3-2	ZW597543	Thrust Washer	KJ-7009
3-3	ZW605698	Thrust Washer (B)	KJ-7009
3-4	ZW597622	Felt Washer	KJ-7022
3-5	SK597633	Cap	KJ-7023
3-6x	ZS608308	Screw, pan head 3x18, w/washer	
3-7	BZ308315	Detection Gear Assy GX-635D	
3-8	MV368886	Steel Ball D3	
3-9	MZ585900	Shaft Support	LS-1203
3-10	MZ597690	Ball Holder	KJ-7029
3-11	ZW413278	Nut M5, #1	
3-12	ZS413201	Screw, pan head 4x8	

When ordering parts, Please describe Parts Number, Description, and Model Number in detail.

#### 4. ILLUSTRATION OF REEL TABLE BLOCK

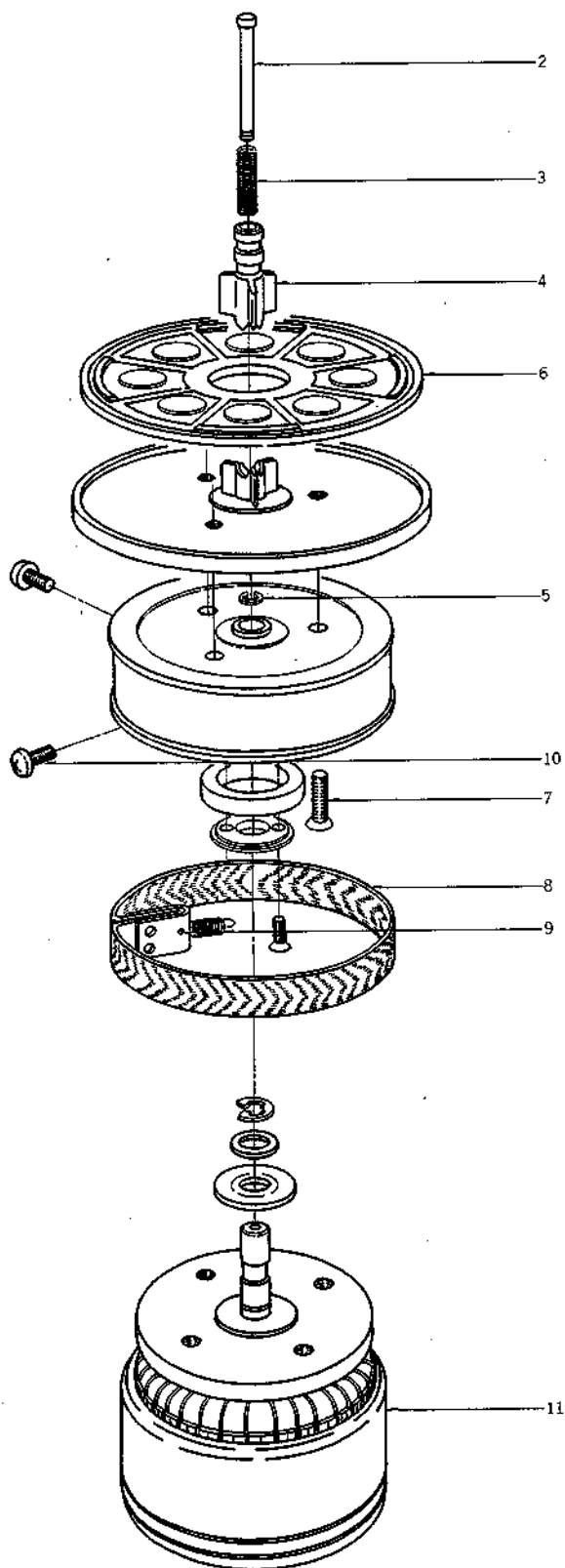

#### 4) REEL TABLE BLOCK

Ref. No.	Parts No.	Description	Schematic No.
4-1x	BR587553	Reel Table Block Comp. TE (Take-up)	
4-2	MS342000	Reel Shaft	3R-108
4-3	ZG540617	Clamper Spring	TW-2096
4-4	MT534677	Reel Clamper	TW-2032
4-5	ZW270088	'E' Ring 1.9M	6-1-9
4-6	MT534688	Reel Table Rubber	TW-2033
4-7	ZS419670	Screw, pan head 3x12	
4-8	MT436860	Brake Cloth Comp. MR	MR-269
4-9	ZG317496	Felt Tension Spring	MR-260
4-10	ZS424056	Screw, pan head 4x10	

#### MOTOR BLOCK

4-11	BMS87518	Motor Block Comp. 24XO-TD TE	
------	----------	------------------------------	--

When ordering parts, Please describe Parts Number, Description, and Model Number in detail.

## 5. ILLUSTRATION OF ROLLER BLOCK

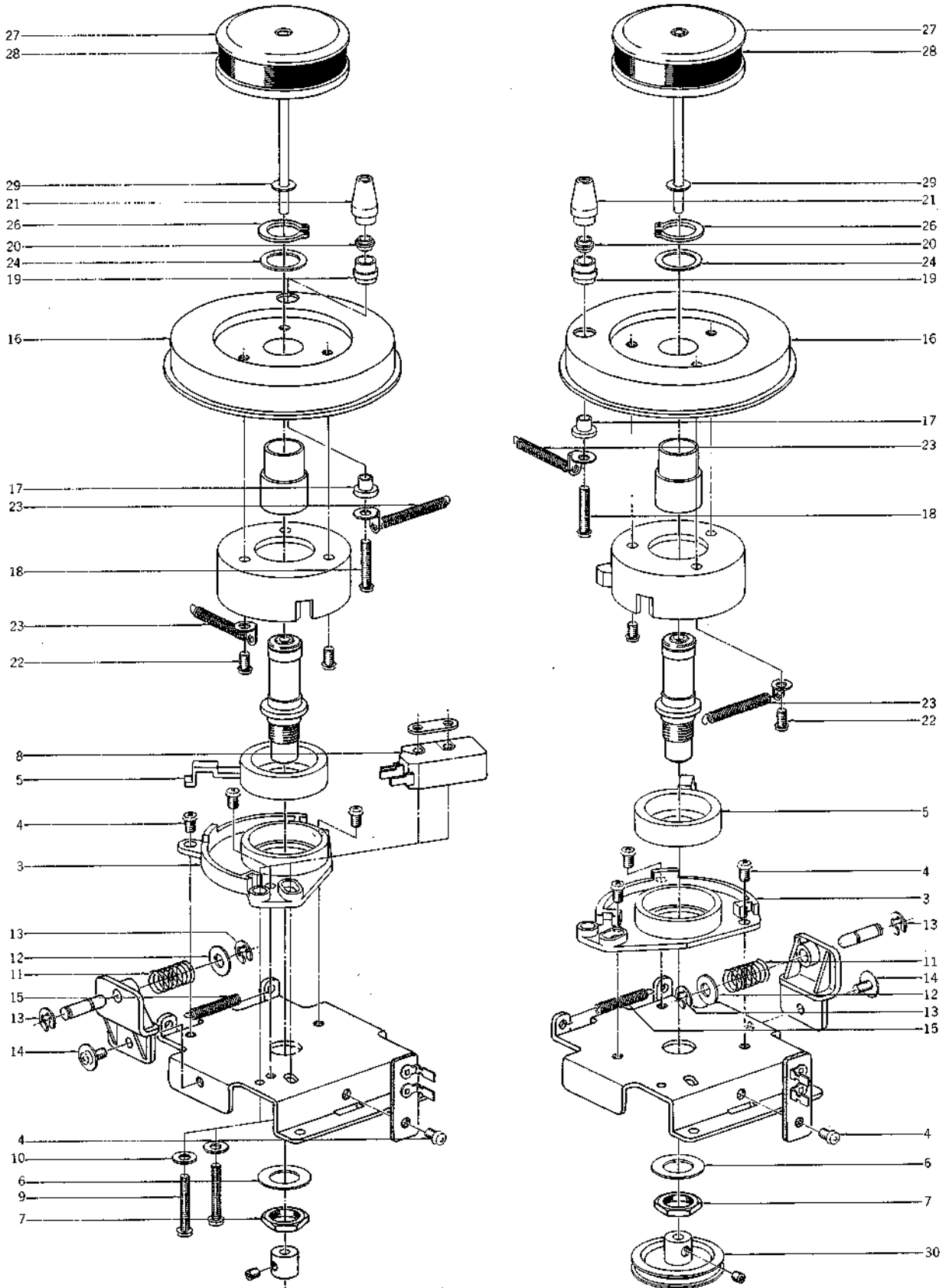

## 5) ROLLER BLOCK

Ref. No.	Parts No.	Description	Schematic No.
5-1x	BZ308227	Roller (L) Block Comp. GX-635D	
5-2x	BZ308228	Roller (R) Block Comp. GX-635D	
5-3	SZ308717	Arm. Damper Base	TH-2013
5-4	ZS417216	Screw, pan head 3x4	
5-5	SZ308718	Arm Damper	TH-2014
5-6	EW308922	Washer D9.2x15x0.5t (ALP)	
5-7	ZW302896	Nut D9x11x2t (P=0.75)	
5-8	ES308929	Micro SW. VV-S	25-1-55
5-9	ZS308931	Screw, 2.6x18 (Pan)	
5-10	ZW550697	Washer (SPC) D2.9x7.4x0.5t	
5-11	ZG308722	Lock Spring	TH-2018
5-12	ZW308930	Washer D4.2x9x0.25t (PBP)	
5-13	ZW270101	'E' Ring 3M	6-1-9
5-14	ZS608321	Screw, pan head 3x6, W=8	
5-15	ZG567685	Azimuth Spring (1)	CP-0040
5-16	MI308707	Tension Wheel	TH-2004
5-17	EZ308712	Insu. Bush	TH-2008
5-18	ZS422965	Screw, pan head 3x15	
5-19	HZ308710	Tape Guide (B)	TH-2007
5-20	MZ535072	Insulator Bush (A)	TW-2075
5-21	HZ308709	Tape Guide (A)	TH-2006
5-22	ZS479474	Screw, pan head 2.6x5	
5-23	ZG312399	Spring T1-3.2/0.2-31.5	
5-24	ZW308927	Washer D10.2x14x0.5t (Nylon)	
5-25x	ZW313822	Washer D10.2x14x0.13t (Polyslider)	
5-26	ZW307294	'C' Ring STW-10-C-3	6-1-3
5-27	MR308713	Counter Roller	TH-2009
5-28	MB308714	Roller Belt	TH-2010
5-29	ZW308928	Washer D2.4x7x0.2t (Teflon)	
5-30	MR308715	Roller Pulley (only R)	TH-2011

# 6. ILLUSTRATION OF POWER SUPPLY BLOCK

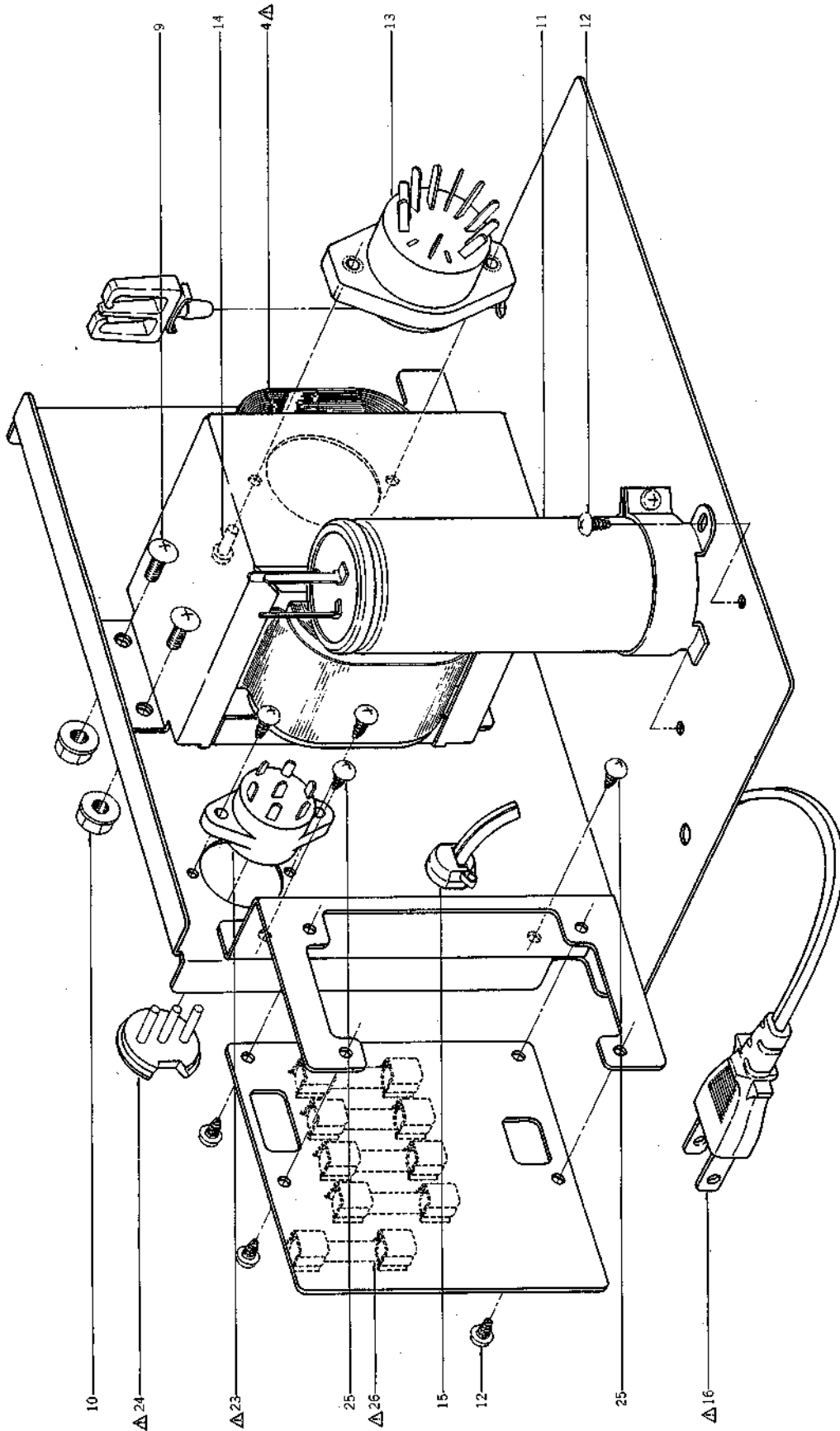

## 6) POWER SUPPLY BLOCK

Ref. No.	Parts No.	Description	Schematic No.
<b>FUSE P.C BOARD BLOCK</b>			
6-1x	EC551160	△ Ceramic/C. DB821 NA 0.01μF (Z) 1.4 KWV (U/T, JPN)	24-5-55
6-2x	EC294118	△ Ceramic/C. DPN6600 YM 0.01μF (P) 125WV (CSA, AAL)	24-5-70
6-3x	EC301320	△ MP/C. 4700PF (M) 250WV (CEE, UK)	24-9-122
<b>POWER SUPPLY P.C BOARD</b>			
6-4	BT308918	△ Power Trans. THT-1 (U/T)	38-4-667
6-5x	BT308919	△ Power Trans. THT-2 (JPN)	38-4-668
6-6x	BT308921	△ Power Trans. THT-4 (CSA, AAL)	38-4-670
6-7x	BT308920	△ Power Trans. THT-3 (CEE, UK)	38-4-669
6-8x	ZW308916	Washer D4.5×10×1t	
6-9	ZS435273	Screw, blinding head 4×10	
6-10	ZW413267	Flange Nut M4	
6-11	EC249592	MP/C. 4+4μF 250WV	24-9-116
6-12	ZS325495	Tapping Screw #2, 3×6 (BR)	
6-13	EJ307274	9P Remo. Con Socket	31-1-223
6-14	ZS421740	Screw, pan head 3×8 (Black)	
6-15	EZ631945	Strain Relief SR-4N-4 (U/T, JPN, CSA, AAL)	2-7-49
6-16	EW306428	△ AC Cord (U/T)	26-3-64
6-17x	EW306427	△ AC Cord (JPN)	26-3-63
6-18x	EW305691	△ AC Cord CUL (CSA, AAL)	26-3-65
6-19x	EJ301513	△ 2P Inlet (CEE, UK)	31-1-200
6-20x	ES313792	△ Slide SW. TSS012183 (CEE, UK)	26-3-148
6-21x	ZS447761	Tapping Screw #2, 3×6(BR) (Black) (CEE, UK)	
6-22x	ZS422076	Screw, pan head 3×5 (CEE, UK)	
6-23	EJ262732	△ Socket (Volt. Selector) (U/T)	31-1-190
6-24	EJ249467	△ Voltage Selector (U/T)	42-1-109
6-25	ZS463353	Tapping Screw #2, 3×8(BR) (Black) (U/T)	
6-26	EF563681	△ Fuse 1A 250V (U/T)	39-1-50
6-27x	EF563703	△ Fuse 2A 250V (U/T, JPN)	39-1-50
6-28x	EF616555	△ Fuse 1.6A 250V (U/T, JPN)	39-1-50
6-29x	EF575932	△ Fuse 0.8A 250V (U/T, JPN)	39-1-50
6-30x	EF659698	△ Fuse SS-2 2A 250V (CSA, AAL)	39-1-56
6-31x	EF308923	△ Fuse SS-2 1.6A (CSA, AAL)	39-1-56
6-32x	EF683313	△ Fuse SS-2 0.8A 250V (CSA, AAL)	39-1-56
6-33x	EF593706	△ Fuse (SEMKO T Type) 500mAT (CEE, UK)	39-1-53
6-34x	EF623103	△ Fuse (SEMKO T Type) 1AT (CEE, UK)	39-1-53



# 7. ILLUSTRATION OF MECHA ASSEMBLY BLOCK

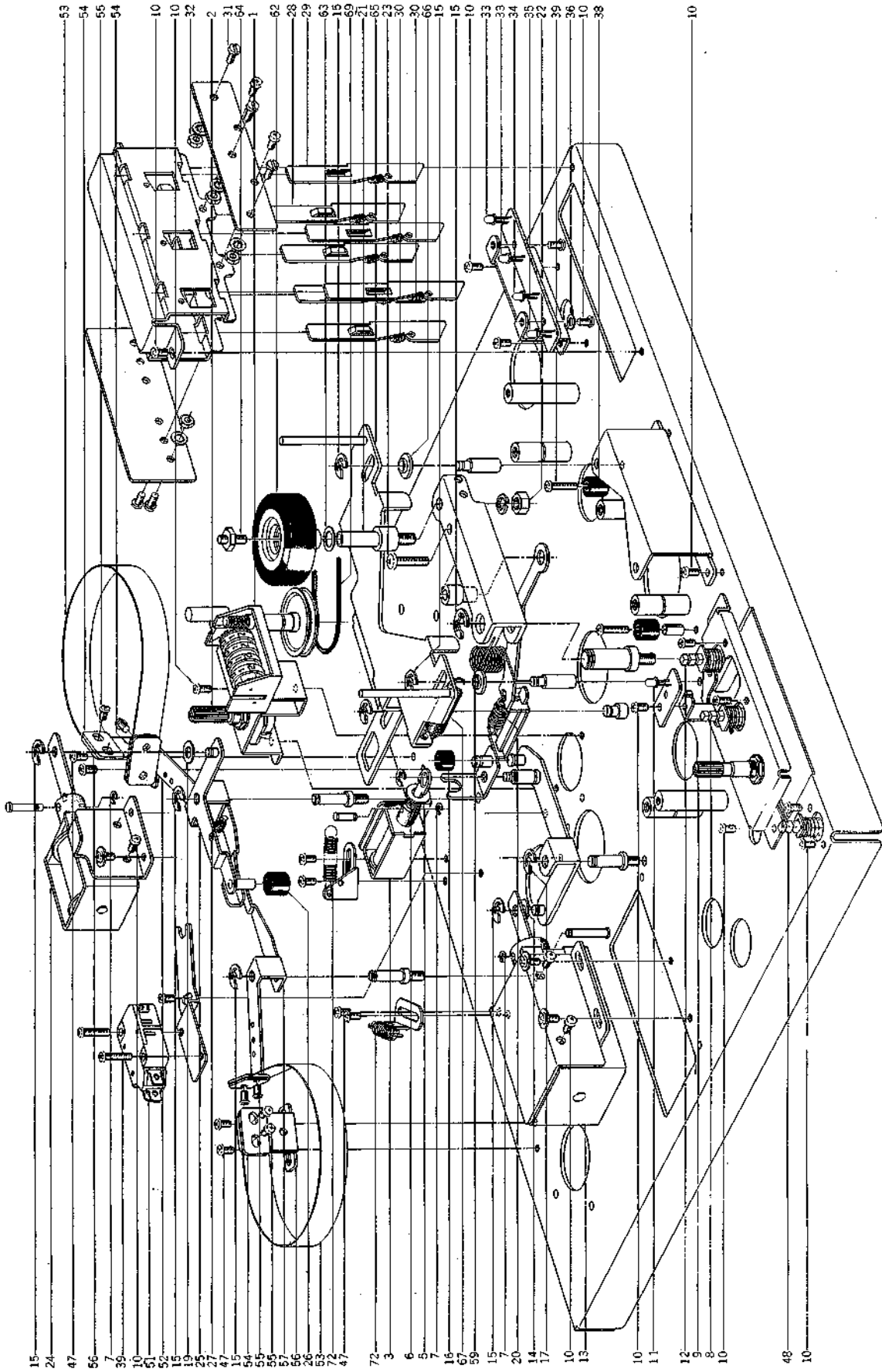

## 7) MECHA ASSEMBLY BLOCK

Ref. No.	Parts No.	Description	Schematic No.	Ref. No.	Parts No.	Description	Schematic No.
<b>COUNTER BLOCK</b>							
7-1	MC308242	Counter Part MP499-07	9-1-67	7-58x	ZS608321	Screw, pan head 3x6, W=8	
7-2	EV308917	Vol. VM10E 1 kB	36-6-34	7-59	ZG301340	Pinch Roller Spring	NE-2237
<b>PAUSE PLUNGER BLOCK</b>							
7-3	EP309056	Plunger TDS-07A	44-1-105	7-60x	ZW270156	'E' Ring 6M	6-1-9
7-4x	ZS592378	Screw, pan head 2.6x3		7-61x	ZW270101	'E' Ring 3M	6-1-9
7-5	ZW313593	Washer (PBP) D5.1x10.3x0.5t		7-62	MP424023	Pinch Roller KD D=37	KD-1084
7-6	ZG308734	Joint Spring	TH-2031	7-63	ZW376391	Washer (Polyslider) D6.1x10x0.13t	
7-7	ZW270088	'E' Ring 1.9M	6-1-9	7-64	ZS527681	Pinch Roller Set Screw	ND-6019
<b>SW. BLOCK</b>							
7-8	ES308914	Push SW. SUF12	25-5-301	7-65	ML308904	Shifter Slide Part	TH-1012
7-9	ES308913	Rotary SW. SRU1023S	25-6-161	7-66	ZW580173	Guide Washer	TD-1055
7-10	ZS422076	Screw, pan head 3x5		7-67	ZG313099	Coil Spring T1-8.0/0.5-31.5	
7-11	ED698826	LED SR-105D	45-15-16	7-68x	ZS309096	Screw, 3x6 (Pan) w/Plug	
7-12	ES308925	Push SW. SUF12	25-5-304	7-69	MB308701	Counter Belt	TH-1014
<b>PR PLUNGER BLOCK</b>							
7-13	EP310448	Plunger 1664TLT	44-1-106	7-70x	ZW330412	Adjust. Washer (U) D4x13x0.13t	
7-14	ZW678723	Washer D6.2x13x0.2t (Teflon)		7-71x	ZW330423	Adjust. Washer (U) D4x13x0.25t	
7-15	ZW290283	'U' Ring, 2.85M	6-1-1	7-72	ZG672478	Brake Spring	TE-1017
7-16	MB428343	Stopper Rubber, KD	KD-1088				
7-17	ZW270123	'E' Ring, 4M	6-1-9				
7-18x	ZW260076	Washer (Nylon) D6.1x10x0.5t					
7-19	ZW420682	Washer (Nylon) D4.2x9x0.5t					
7-20	ZG308728	P Spring	TH-2025				
7-21	MSS27591	Pinch Roller Shaft	ND-1030				
7-22	ZW413278	Nut M5, #1					
7-23	ZS444262	Screw, binding head 4x18					
<b>BRAKE PLUNGER BLOCK</b>							
7-24	EP310447	Plunger 1240TLT	44-1-107				
7-25	ML308905	Brake Lever Part GX-635D	TH-2027				
7-26	MZ397181	Lever Cushion	KD-1069				
7-27	ZG580522	Clutch Lever Spring	TD-2045				
<b>OPERATION BLOCK</b>							
7-28	ML308737	Operation Plate (A)	TH-2034				
7-29	ML308677	Operation Plate (B)	TH-2034				
7-30	ZG576314	FF Idler Spring	PW-2030				
<b>OPERATION P.C BOARD (A) BLOCK</b>							
7-31	ZS302720	Screw, flat head 3x6 (Black)					
7-32	ZW273756	Nut M3, #1					
<b>LED P.C BOARD BLOCK</b>							
7-33	ED283138	LED GL-3PG1	45-15-15				
7-34	ED303005	LED GL-3PY1	45-15-18				
7-35	ED698826	LED SR-105D	45-15-16				
7-36	ZW309054	Washer D3x6x0.2t (Nylon)					
<b>MECHA ASSEMBLY BLOCK</b>							
7-37x	ZS413201	Screw, pan head 4x8					
7-38	MB606712	Stopper Rubber KJ	KJ-2060				
7-39	ZS419670	Screw, pan head 3x12					
7-40x	ZW273914	Spring Washer, M4					
7-41x	ZW413188	Nut M4, #1					
7-42x	ZW274026	Spring Washer, M5					
7-43x	ZW413278	Nut M5, #1					
7-44x	ZS325495	Tapping Screw #2, 3x6 (BR)					
7-45x	SA312529	Rubber Foot (A-2) Part	LE-6739				
7-46x	ZS417150	Screw, pan head 4x6					
7-47	ZS323728	Screw, binding head 3x5					
7-48	ES313622	Δ Push SW. JP-27 (w/o label) (U/T, JPN)	25-5-318				
7-49x	ES309059	Δ Push SW. JP-27 (CSA, AAL)	25-5-285				
7-50x	ES309058	Δ Push SW. JP-24 (CEE, UK)	25-5-286				
7-51	ES573478	Micro SW. K-3	25-1-31				
7-52	ML582041	Brake Lever (A)	TD-1019				
7-53	MT314987	Brake Band	MR-213				
7-54	MZ314998	Brake Retaining Plate	MR-212				
7-55	ZS417216	Screw, pan head 3x4					
7-56	ML582074	Brake Band Support	TD-1023				
7-57	ML533643	Brake Lever (B)	TW-1030				

When ordering parts, Please describe Parts Number, Description, and Model Number in detail.

## 8. P.C BOARDS

### (1) SYS. CON P.C BOARD (TH-1015) BLOCK

Symbol No.	Parts No.	Description	Schematic No.	Symbol No.	Parts No.	Description	Schematic No.
(1)-1	BA308262	Sys. Con P.C Board Comp. GX-635D (U/T) (JPN)		(1)-D50	ED308941	Silicon Diode SVB10-200	45-2-82
(1)-2	BA308263	Sys. Con P.C Board Comp. GX-635D (CSA) (AAL)		(1)-D51,52	ED224550	Silicon Diode 10D4	45-2-16
(1)-3	BA308264	Sys. Con P.C Board Comp. GX-635D (CEE) (UK)		(1)-D53	ED560913	Silicon Diode 1S2473 VE	45-3-23
(1)-IC1	EI308936	IC M54410P	45-8-304	(1)-D54	ED224550	Silicon Diode 10D4	45-2-16
(1)-IC2,3	EI430661	IC M53200P	45-8-38	(1)-D55	ED560913	Silicon Diode 1S2473 VE	45-3-23
(1)-IC4	EI633960	IC M53202P	45-8-140	(1)-D56	ED224550	Silicon Diode 10D4	45-2-16
(1)-IC5	EI573840	IC M53204P	45-8-106	(1)-D57	ED560913	Silicon Diode 1S2473 VE	45-3-23
(1)-TR1	ET312497	Transistor 2SC1061(B)(C) YC-408	45-1-96	(1)-RL1to4	EP309061	Relay FRL-264	47-1-37
(1)-TR2	ET639437	Transistor 2SC945L(Q)(P)	45-1-85	(1)-RL5	EP308949	Relay BR211	47-2-31
(1)-TR3	ET307349	Transistor 2SD794(P)(Q)	45-1-334	(1)-RL6	EP280743	Relay BR111CD024D	47-1-31
(1)-TR4to8	ET639437	Transistor 2SC945L(Q)(P)	45-1-85	(1)-SW1	ES309094	Slide SW. SL13-6-6-2-2-B	25-3-159
(1)-TR9,10	ET554657	Transistor 2SA733(P)(Q)	45-1-124	(1)-VR1	EV302718	Semi-fixed/Vol. V18K3-6 (4US) 50 kB	36-9-26
(1)-TR11	ET639437	Transistor 2SC945L(Q)(P)	45-1-85	(1)-VR2	EV309071	Semi-fixed/Vol. V18K3-6 (4US) 20 kB	36-9-26
(1)-TR12	ET554657	Transistor 2SA733(P)(Q)	45-1-124	(1)-CR1to14	ER300820	Spark Quencher CRU-112 0.1μ+120 ohms 125WV	41-1-63
(1)-TR13	ET308947	Transistor 2SC2336B(Q)(R)	45-1-333	(1)-R110	ER309092	Metal Oxide Film/R. 2W 820 ohms(K)	35-15-8
(1)-TR14,15	ET639437	Transistor 2SC945L(Q)(P)	45-1-85	(1)-R111	ER308956	Cement/R. (Home. Type) 20W 220 ohms(K)	35-16-81
(1)-TR16to19	ET308937	Transistor 2SC2130(G)(H)	45-1-317	(1)-R112	ER308955	Cement/R. (Home. Type) 20W 36 ohms(K)	35-16-81
(1)-TR20	ET522268	Transistor 2SA733(Q)	45-1-124	(1)-C1	EC295997	Elect./C. (Vert. Type) 2200μF 35WV	24-12-9
(1)-TR21	ET399846	Transistor 2SC945L(Q)	45-1-85	(1)-C4	EC450270	Elect./C. (Vert. Type) 1000μF 25WV	24-12-9
(1)-TR22	ET308937	Transistor 2SC2130(G)(H)	45-1-317	(1)-C5	EC459145	Elect./C. (Vert. Type) 2200μF 16WV	24-12-9
(1)-TR23	ET639437	Transistor 2SC945L(Q)(P)	45-1-85	(1)-C7	EC220410	Elect./C. (Vert. Type) 1000μF 10WV	24-12-9
(1)-TR24,25	ET308937	Transistor 2SC2130(G)(H)	45-1-317	(1)-C19	EC310370	Metalized Film/C. (Vert. Type) 1.5μF(K) 180WV	24-16-12
(1)-TR26to32	ET639437	Transistor 2SC945L(Q)(P)	45-1-85	(1)-C20	EC310368	Metalized Film/C. (Vert. Type) 3.5μF(K) 180WV	24-16-13
(1)-D1	ED308945	Silicon Diode SVB10-100	45-2-82	(1)-C35to37	EC304708	Tantalum/C. (D Type) 47μF(M) 6.3WV	24-15-12
(1)-D2	ED313623	Zener Diode HZ22-3	45-6-80	(1)-C39,40	EC304186	NP/C. (Vert. Type) 10μF(M) 16WV	24-17-26
(1)-D3	ED308945	Silicon Diode SVB10-100	45-2-82	(1)-C44,45	EC308940	NP/C. (Home. Type) 0.47μF(M) 50WV	24-17-31
(1)-D4	ED309069	Zener Diode HZ6B-2	45-6-80	(1)-C46,47	EC308950	Tantalum/C. 10μF(M) 6.3WV	24-15-12
(1)-D5	ED308951	Zener Diode WZ-120	45-6-87	(1)-C48	EC308943	Elect./C. 470μF 160WV	24-12-32
(1)-D6	ED510772	Zener Diode WZ-120	45-6-87	(1)-C49	EC313577	Elect./C. (Vert. Type) 100μF 100WV	24-12-46
(1)-D7,8	ED560913	Silicon Diode 1S2473 VE	45-3-23	(1)-C52	EC310366	Metalized Film/C. (Vert. Type) 0.47μF(M) 150WV	24-16-11
(1)-D9	ED308941	Silicon Diode SVB10-200	45-2-82	(1)-C53	EC310374	Tantalum/C. (D Type) 100μF(M) 3.15WV	24-15-12
(1)-D10,11	ED308952	Germanium Diode (Stop. Type) 1K34A-LR	45-3-47	(1)-C101to128	EC310372	Metalized Film/C. (Vert. Type) 0.1μF(M) 200WV (CEE, UK)	24-16-14
(1)-D12,13	ED308953	Germanium Diode (Home. Type) 1K34A-LH	45-3-46	(1)-4	ZS421806	Screw, pan head 3x8	
(1)-D14	ED308952	Germanium Diode (Stop. Type) 1K34A-LR	45-3-47	(1)-5	ZW273756	Nut M3, #1	
(1)-D15	ED624903	Silicon Diode 1S2473	45-3-28				
(1)-D16	ED560913	Silicon Diode 1S2473 VE	45-3-23				
(1)-D17	ED308952	Germanium Diode (Stop. Type) 1K34A-LR	45-3-47				
(1)-D18	ED624903	Silicon Diode 1S2473	45-3-28				
(1)-D19to22	ED560913	Silicon Diode 1S2473 VE	45-3-23				
(1)-D24	ED624903	Silicon Diode 1S2473	45-3-28				
(1)-D26	ED560913	Silicon Diode 1S2473 VE	45-3-23				
(1)-D27	ED624903	Silicon Diode 1S2473	45-3-28				
(1)-D28	ED308953	Germanium Diode (Home. Type) 1K34A-LH	45-3-46				
(1)-D29to32	ED560913	Silicon Diode 1S2473 VE	45-3-23				
(1)-D33,34	ED308952	Germanium Diode (Stop. Type) 1K34A-LR	45-3-47				
(1)-D35	ED624903	Silicon Diode 1S2473	45-3-28				
(1)-D36to38	ED308952	Germanium Diode (Stop. Type) 1K34A-LR	45-3-47				
(1)-D39,40	ED560913	Silicon Diode 1S2473 VE	45-3-23				
(1)-D41,42	ED308953	Germanium Diode (Home. Type) 1K34A-LH	45-3-46				
(1)-D43	ED560913	Silicon Diode 1S2473 VE	45-3-23				
(1)-D44	ED308952	Germanium Diode (Stop. Type) 1K34A-LR	45-3-47				
(1)-D45	ED308953	Germanium Diode (Home. Type) 1K34A-LH	45-3-46				
(1)-D46	ED308952	Germanium Diode (Stop. Type) 1K34A-LR	45-3-47				
(1)-D47,48	ED560913	Silicon Diode 1S2473 VE	45-3-23				
(1)-D49	ED306109	Silicon Diode W03B	45-2-78				

When ordering parts, Please describe Parts Number, Description, and Model Number in detail.

## (2) PRE AMP P.C BOARD (TH-5001A) BLOCK

Symbol No.	Parts No.	Description	Schematic No.
(2)-1	BA308275	Pre Amp P.C Board Comp. GX-635D (U/T) (JPN, CSA, AAL)	
(2)-2	BA308296	Pre Amp P.C Board Comp. GX-635D (CEE) (UK)	
(2)-IC1	EI306141	IC LA4170	45-8-305
(2)-TR1to3	ET352146	Transistor 2SC458LG(D)	45-1-29
(2)-TR4	ET308975	Transistor 2SC458(D)	45-1-26
(2)-TR5,6	ET638504	Transistor 2SC945L(P)	45-1-85
(2)-TR7to9	ET352146	Transistor 2SC458LG(D)	45-1-29
(2)-TR10	ET638504	Transistor 2SC945L(P)	45-1-85
(2)-TR11	ET308978	FET 2SK68(M)	45-12-14
(2)-TR12	ET311336	Transistor 2SC2130(H)	45-1-317
(2)-TR13to15	ET639437	Transistor 2SC945L(Q)(P)	45-1-85
(2)-TR16	ET208012	Transistor 2SD571(K)	45-1-218
(2)-TR17to23	ET639437	Transistor 2SC945L(Q)(P)	45-1-85
(2)-D1,2	ED308952	Germanium Diode (Stop. Type) 1K34A-LR	45-3-47
(2)-D3	ED560913	Silicon Diode 1S2473 VE	45-3-23
(2)-D4	ED308952	Germanium Diode (Stop. Type) 1K34A-LR	45-3-47
(2)-D5to8	ED560913	Silicon Diode 1S2473 VE	45-3-23
(2)-L1	EO301448	Inductor 45H-044 1MH	23-1-277
(2)-L2	EO301467	Ferri Inductor RX-9P 3.3MH(J)	23-1-275
(2)-L3	EO308982	Inductor 22MH	23-1-300
(2)-L4	EO308974	OSC Coil 49H-364	23-4-50
(2)-L5,6	EO313608	Ferri Inductor FL9H 270μH(J)	23-1-314
(2)-J1	EJ305629	Headphone Jack JL3A	31-2-90
(2)-J2	EJ305739	Mic Jack JU2	31-2-89
(2)-J3	EJ308986	4P PIN Jack (U/T, JPN, CSA, AAL)	31-5-145
(2)-J3	EJ306985	4P PIN Jack (CEE, UK)	31-5-142
(2)-SW1	ES301435	Slide SW. CL-210E	25-3-136
(2)-SW2	ES308984	Push SW. SUF44	25-5-302
(2)-SW3	ES308983	Push SW. J-K2023	25-5-305
(2)-SW4	ES301436	Slide SW. CL-206E	25-3-135
(2)-SW5	ES301715	Slide SW. SSB02214	25-3-127
(2)-SW6	ES306292	Leaf SW. BSW-86	25-10-31
(2)-VR1,2	EV305637	Semi-fixed/Vol. D8 Axial Type 10 kB	36-10-273
(2)-VR3,4	EV305636	Semi-fixed/Vol. D8 Axial Type 50 kB	36-10-273
(2)-VR5	EV306989	Semi-fixed/Vol. D8 Axial Type 1 kB	36-10-273
(2)-VR6	EV301437	Single Axial 2 Throw Vol. GM70R-715 10 kBx2	36-22-28
(2)-VR7	EV308966	Semi-fixed/Vol. D8 Axial Type 30 kB	36-10-273
(2)-P1,2	EJ249333	Micro Connector 4P Plug W-P0504	42-1-104
(2)-P3,4	EJ249366	Micro Connector 7P Plug W-P0507	42-1-104
(2)-RL1	EP308973	Relay LAB2NS	47-2-30
(2)-R82	ER306299	Metal Oxide Film/R. (Homing Type) 2W 390 ohms(J)	35-11-22
(2)-TC1,2	EC558202	Trimmer/C. TM-80A 80PF	24-2-26
(2)-C1	EC313868	Elect./C. (LL, Homing) 10μF(M) 16WV	24-20-19
(2)-C3	EC305677	Styrol/C. 200PF(K) 50WV	24-11-14
(2)-C15	EC313624	Elect./C. (LL, Homing) 22μF(M) 25WV	24-20-19
(2)-C20	EC306420	Styrol/C. (Homing Type) 750PF(J) 50WV	24-11-14
(2)-C22	EC313868	Elect./C. (LL, Homing) 10μF(M) 16WV	24-20-19
(2)-C25	EC308990	Styrol/C. (Homing Type) 470PF(K) 50WV	24-11-14
(2)-C29	EC305677	Styrol/C. (Homing Type) 200PF(K) 50WV (R)	24-11-14
(2)-C29	ECS16701	Styrol/C. (Vert. Type) 200PF(K) 50WV (L)	24-11-3

Symbol No.	Parts No.	Description	Schematic No.
(2)-C30	EC306987	Styrol/C. (Homing Type) 470PF(J) 50WV (R)	24-11-14
(2)-C30	EC405898	Styrol/C. (Vert. Type) 470PF(J) 50WV (L)	24-11-3
(2)-C32	EC305677	Styrol/C. (Homing Type) 200PF(K) 50WV	24-11-14
(2)-C36	EC306438	Styrol/C. (Homing Type) 100PF(J) 50WV	24-11-14
(2)-C48	EC313265	Styrol/C. (Vert. Type) 150PF(J) 50WV	24-11-3

## (3) VOL. P.C BOARD (TH-5002) BLOCK

Symbol No.	Parts No.	Description	Schematic No.
(3)-VR1,2	EV308995	Double Axial 2 Throw Vol. DM20R 50 kAx2	36-18-9

## (4) REC, LED P.C BOARD (TH-5001B) BLOCK

Symbol No.	Parts No.	Description	Schematic No.
(4)-D1,2	ED249377	LED GL-3AR1	45-15-14

# 9. ILLUSTRATION OF AMP ASSEMBLY BLOCK

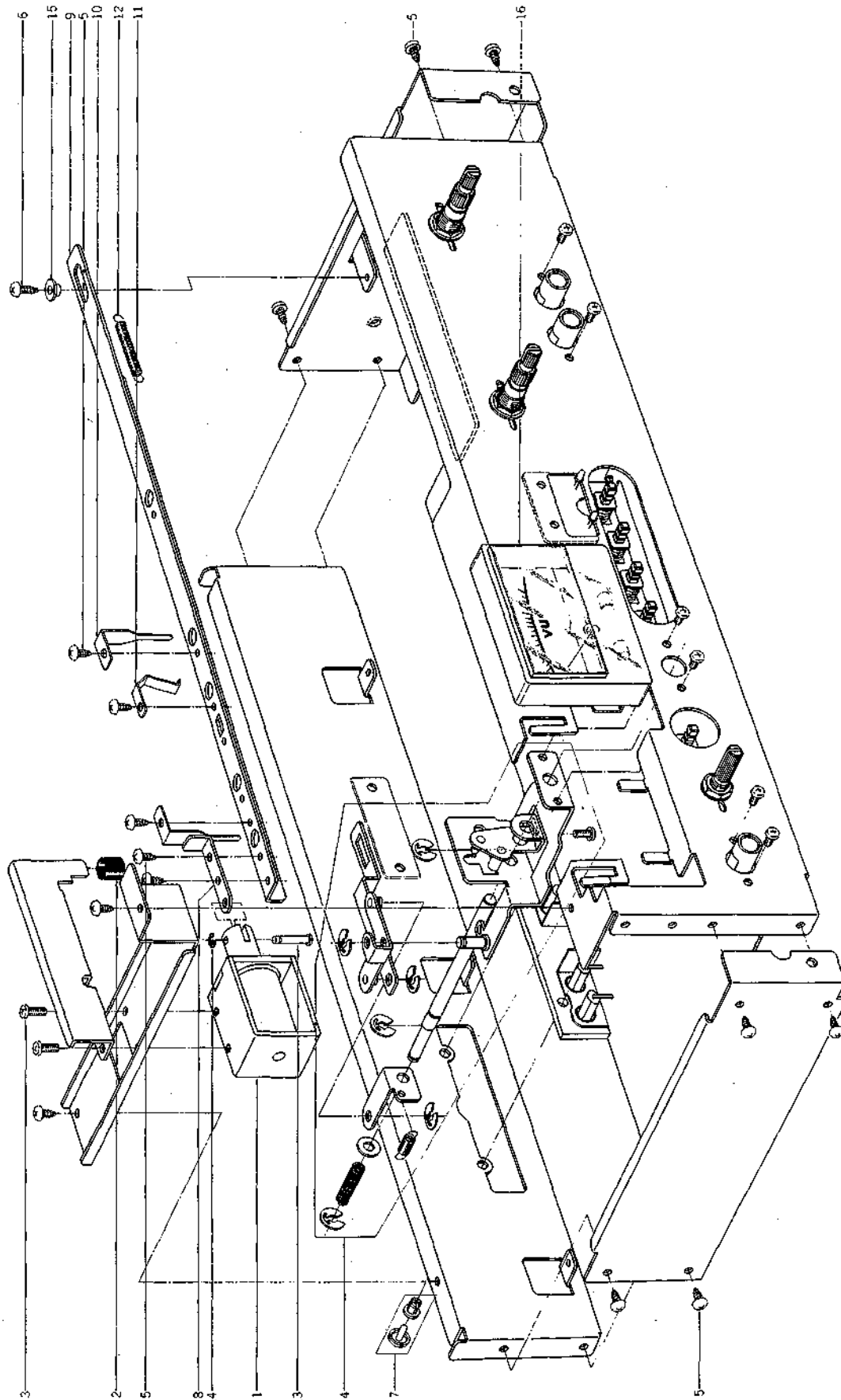

## 9) AMP ASSEMBLY BLOCK

Ref. No.	Parts No.	Description	Schematic No.
<b>REVERSE PLUNGER BLOCK</b>			
9-1	EP310447	Plunger 1240TLT	44-1-107
9-2	MB606712	Stopper Rubber KJ	KJ-2060
9-3	ZS422076	Screw, pan head 3x5	
<b>TIMER BLOCK</b>			
9-4	BZ308285	Timer Block Comp. GX-635D	TH-2060
<b>AMP ASSEMBLY BLOCK</b>			
9-5	ZS325495	Tapping Screw #2, 3x6 (BR)	
9-6	ZS447840	Tapping Screw #2, 3x8 (BR)	
9-7	ZW263946	Nylon Rivet 4x5	2-7-57
9-8	MZ301084	Reverse Joint	NE-5219
9-9	ML301123	Reverse Arm	NE-5218
9-10	ZG301072	Reverse SW. Spring (A)	NE-5206
9-11	ZG301073	Reverse SW. Spring (B)	NE-5207
9-12	ZG312400	Spring T1-4.0/0.4-31.5	
9-13	MH257477	Connecting Pin	RD-211
9-14	ZW270088	'E' Ring 1.9M	6-1-9
9-15	ZW625241	Graduated Washer	MY-1013
9-16	EM309051	VU Meter VU-50-003	
		(U/T, CSA, AAL, CEE, UK)	46-1-209
9-17x	EM309050	VU Meter VU-50-005 (JPN)	46-1-199

## 10. PHOTO OF FINAL ASSEMBLY BLOCK

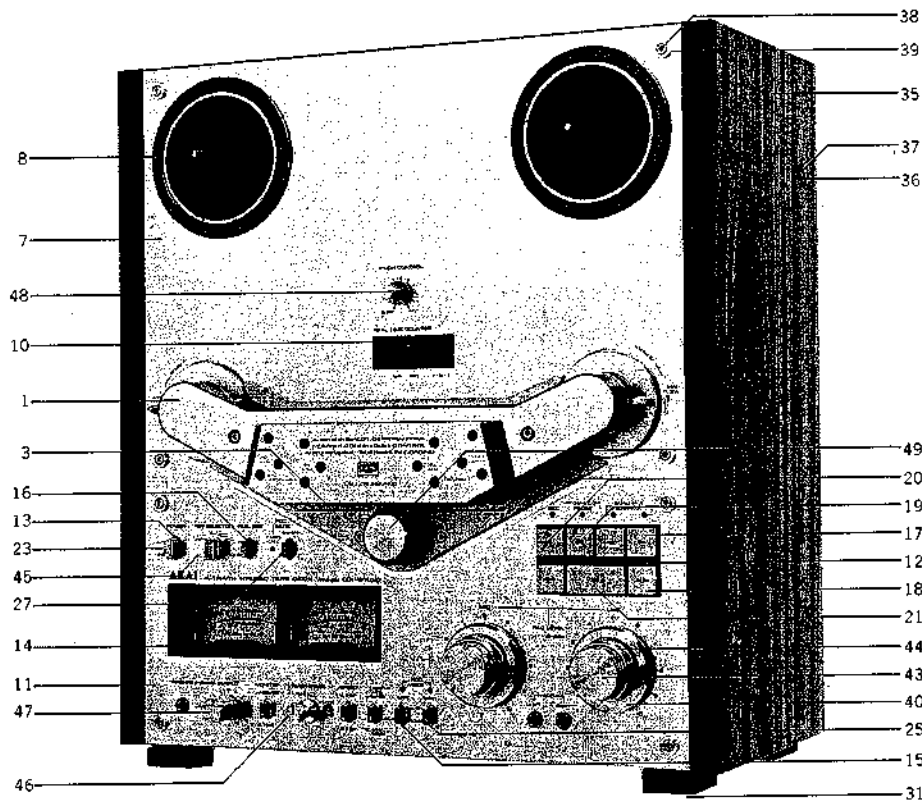

### 10) FINAL ASSEMBLY BLOCK

Ref. No.	Parts No.	Description	Schematic No.	Ref. No.	Parts No.	Description	Schematic No.
<b>HEAD COVER BLOCK</b>				10-14	SE308780	Meter Escutcheon	TH-6010
10-1	BZ308220	Head Cover Block Comp. GX-635D (U/T)		10-15	SE306143	Button Escutcheon (A)	CN-6308
		(CSA, CEE, UK)	TH-6055	10-16	SE305651	Button Escutcheon (B)	CN-6352
10-2x	BZ308219	Head Cover Block Comp. GX-635D (AAL)	TH-6055	10-17	SB308911	Operate Button (A)	
						Part GX-635D	TH-6018
<b>HEAD COVER BASE BLOCK COMP.</b>				10-18	SB308910	Operate Button (B)	
10-3	SC308813	Head Cover Base	TH-6040			Part GX-635D	TH-6020
10-4x	ML308810	Head Cover Holder (A)	TH-6038	10-19	SB308909	Operate Button (C)	
10-5x	ML308811	Head Cover Holder (B)	TH-6038			Part GX-635D	TH-6021
10-6x	ZS608321	Screw, pan head 3x6, w=8		10-20	SB308908	Operate Button (D)	
						Part GX-635D	TH-6022
<b>MECHA PANEL BLOCK</b>				10-21	SB308907	Operate Button (E)	
10-7	BD308215	Mecha Panel Block Comp. GX-635D				Part GX-635D	TH-6019
10-8	SE301134	Reel Table Escutcheon (2-B)	TD-6021	10-22x	SZ311866	Ring Felt	TH-6054
10-9x	ZW575730	Speed Nut (P Type) (3)	6-3-6	10-23	SB308785	Button (A)	TH-6015
10-10	SE308784	Counter Escutcheon	TH-6014	10-24x	ZG308787	Button Spring	TH-6017
				10-25	SK305653	Push Button (A)	CN-6309
				10-26x	ZG305657	Button Spring	CN-6310
				10-27	SK305654	Push Button (B)	CN-6309
				10-28x	ZG305657	Button Spring	CN-6310
<b>AMP PANEL BLOCK</b>				<b>FINAL ASSEMBLY BLOCK</b>			
10-11	BD308217	Amp Panel Block Comp. GX-635D		10-29x	ZS325495	Tapping Screw #2, 3x6 (BR)	
10-12	SE308781	Operate Escutcheon	TH-6011	10-30x	SP308778	Bottom Plate	TH-6068
10-13	SE308786	Button Escutcheon	TH-6016	10-31	SA301411	Square Foot Part GX-215D	2-6-15

When ordering parts, Please describe Parts Number, Description, and Model Number in detail.

Ref. No.	Parts No.	Description	Schematic No.
10-32x	ZS413234	Screw, pan head 4x12	
10-33x	ZS201341	Screw, truss head 4x8 (Black)	
10-34x	BC312396	Upper Cover (B)	NE-6201
10-35	SP308805	Side Plate	TH-6034
10-36	ZS520525	Screw, binding head 4x25 (Black)	
10-37	ZW548010	Spot Facing Washer	MU-6028
10-38	ZS613901	Panel Screw	CW-6031
10-39	ZW308796	Panel Washer	TH-6030
10-40	SZ308782	Memory Ring	TH-6012
10-41x	ML308783	Memory Ring Holder	TH-6013
10-42x	SZ311866	Ring Felt	TH-5054
10-43	SK308791	Double Knob (Upper)	TH-6025
10-44	SK308792	Double Knob (Lower)	TH-6026
10-45	SK308818	Knob (D)	TH-6046
10-46	SK308795	Knob (C)	TH-6029
10-47	SK308793	Knob (A)	TH-6027
10-48	SK308794	Knob (B)	TH-6028
10-49	SK632610	Pinch Roller Cap (B) Part TE	TW-6019
10-50x	SP308798	Back Board (B) (U/T)	TH-6031,6033
10-51x	SP308797	Back Board (A) (JPN)	TH-6031,6032
10-52x	SP308800	Back Board (D) (CSA, AAL)	TH-6031,6050
10-53x	SP308799	Back Board (C) (CEE, UK)	TH-6031,6049
10-54x	ZS297641	Tapping Screw #2, 3x8 (Bind) W=10	
10-55x	ZS422965	Screw, pan head 3x15	



## 11. LIST OF INTERCHANGEABLE SEMICONDUCTORS

If, while servicing, the original parts cannot be obtained, the interchangeable parts listed below can be substituted.

Original Parts			Interchangeable Parts	
Description	Parts No.	Utilizing P.C Board	Description	Parts No.
2SC458 (D)	ET308975	TH-5001A TH-5003A	2SC945L (P)	ET638504
2SC458LG (D)	ET352146	TH-5001A TH-5003A	2SC1844 (E) (F)	ET308954
2SC945L (P)	ET638504	TH-5001A TH-5003A	2SC458 (D)	ET308975
2SC945L (Q) (P)	ET639437	TH-5001A TH-5003A	2SC1815 (GR)	ET308980
2SC2130 (H)	ET311336	TH-5001A TH-5003A	2SC711 (H)	ET429748
2SK68 (M)	ET308978	TH-5001A TH-5003A	2SK117 (GR)	ET303697
M53200P	EI430661	TH-1015	MB400/7400	EI304165
M53202P	EI633960	TH-1015	MB417/7402	EI305238
M53204P	EI573840	TH-1015	MB418/7404	EI304166
1S2473 1S2473VE	ED624903 ED560913	TH-5001A TH-5003A TH-1015	1S1588	ED557447
1K34A-LR 1K34A-LH	ED308952 ED308953	TH-5001A TH-5003A TH-1015	1N34A	ED219464
W03B	ED306109	TH-1015	10D1	ED224526
10D4	ED224550	TH-1015	1N4004	ED570273
SR-105D	ED698826	TH-2043 TH-2046	GL-3AR1	ED249377
GL-3AR1	ED249377	TH-5001B TH-5003B	SR-105D	ED698826

Chart-8

NOTE: Semi-conductors not listed on chart must be replaced by the original parts.

# INDEX

Parts No.	Ref. No. & Symbol No.	Parts No.	Ref. No. & Symbol No.	Parts No.	Ref. No. & Symbol No.	Parts No.	Ref. No. & Symbol No.
BA308262	(1)-1	ED309069	(1)-D4	ES308984	(2)-SW2	ML308904	7-65
BA308263	(1)-2	ED313623	(1)-D2	ES309058	7-50x	ML308905	7-25
BA308264	(1)-3	ED510772	(1)-D6	ES309059	7-49x	ML533643	7-57
BA308275	(2)-1	ED560913	(1)-D7,8	ES309094	(1)-SW1	ML582041	7-52
BA308296	(2)-2	ED560913	(1)-D16	ES313622	7-48	ML582074	7-56
BC312396	10-34x	ED560913	(1)-D19to22	ES313792	6-20x	MP424023	7-62
BD308215	10-7	ED560913	(1)-D26	ES573478	7-51	MR308713	5-27
BD308217	10-11	ED560913	(1)-D29to32	ET208012	(2)-TR16	MR308715	5-30
BH308277	2-1x	ED560913	(1)-D39,40	ET307349	(1)-TR3	MS342000	4-2
BM308310	3-1x	ED560913	(1)-D43	ET308937	(1)-TR16to19	MS527591	7-21
BM587518	4-11	ED560913	(1)-D47,48	ET308937	(1)-TR22	MT314987	7-53
BR587553	4-1x	ED560913	(1)-D53	ET308937	(1)-TR24,25	MT436860	4-8
BT308918	6-4	ED560913	(1)-D55	ET308947	(1)-TR13	MT534677	4-4
BT308919	6-5x	ED560913	(1)-D57	ET308975	(2)-TR4	MT534688	4-6
BT308920	6-7x	ED560913	(2)-D3	ET308978	(2)-TR11	MV368886	3-8
BT308921	6-6x	ED560913	(2)-D5to8	ET311336	(2)-TR12	MZ301084	9-8
BZ308219	10-2x	ED624903	(1)-D15	ET312497	(1)-TR1	MZ314998	7-54
BZ308220	10-1	ED624903	(1)-D18	ET352146	(2)-TR1to3	MZ397181	7-26
BZ308227	5-1x	ED624903	(1)-D24	ET352146	(2)-TR7to9	MZ535072	5-20
BZ308228	5-2x	ED624903	(1)-D27	ET399846	(1)-TR21	MZ585900	3-9
BZ308285	9-4	ED624903	(1)-D35	ET522268	(1)-TR20	MZ597690	3-10
BZ308315	3-7	ED698826	7-11	ET554657	(1)-TR9,10	SA301411	10-31
EC220410	(1)-C7	ED698826	7-35	ET554657	(1)-TR12	SA312529	7-45x
EC249592	6-11	EF308923	6-31x	ET638504	(2)-TR5,6	SB308785	10-23
EC294118	6-2x	EF563681	6-26	ET638504	(2)-TR10	SB308907	10-21
EC295997	(1)-C1	EF563703	6-27x	ET639437	(1)-TR2	SB308908	10-20
EC301320	6-3x	EF575932	6-29x	ET639437	(1)-TR4to8	SB308909	10-19
EC304186	(1)-C39,40	EF593706	6-33x	ET639437	(1)-TR11	SB308910	10-18
EC304708	(1)-C35to37	EF616555	6-28x	ET639437	(1)-TR14,15	SB308911	10-17
EC305677	(2)-C3	EF623103	6-34x	ET639437	(1)-TR23	SC308813	10-3
EC305677	(2)-C29	EF659698	6-30x	ET639437	(1)-TR26to32	SE301134	10-8
EC305677	(2)-C32	EF683313	6-32x	ET639437	(2)-TR13to15	SE305651	10-16
EC306420	(2)-C20	EI306141	(2)-IC1	ET639437	(2)-TR17to23	SE306143	10-15
EC306438	(2)-C36	EI308936	(1)-IC1	EV301437	(2)-VR6	SE308780	10-14
EC306987	(2)-C30	EI430661	(1)-IC2,3	EV302718	(1)-VR1	SE308781	10-12
EC308940	(1)-C44,45	EI573840	(1)-IC5	EV305636	(2)-VR3,4	SE308784	10-10
EC308943	(1)-C48	EI633960	(1)-IC4	EV305637	(2)-VR1,2	SE308786	10-13
EC308950	(1)-C46,47	EJ249333	(2)-P1,2	EV306989	(2)-VR5	SK305653	10-25
EC308990	(2)-C25	EJ249366	(2)-P3,4	EV308917	7-2	SK305654	10-27
EC310366	(1)-C52	EJ249467	6-24	EV308966	(2)-VR7	SK308791	10-43
EC310368	(1)-C20	EJ262732	6-23	EV308995	(3)-VR1,2	SK308792	10-44
EC310370	(1)-C19	EJ301513	6-19x	EV309071	(1)-VR2	SK308793	10-47
EC310372	(1)-C10to128	EJ305629	(2)-J1	EW305691	6-18x	SK308794	10-48
EC310374	(1)-C53	EJ305739	(2)-J2	EW306427	6-17x	SK308795	10-46
EC313265	(2)-C48	EJ306985	(2)-J3	EW306428	6-16	SK308818	10-45
EC313577	(1)-C49	EJ307274	6-13	EW308922	5-6	SK597633	3-5
EC313624	(2)-C15	EJ308986	(2)-J3	EZ308712	5-17	SK632610	10-49
EC313868	(2)-C1	EJ310390	2-30	EZ631945	6-15	SP308778	10-30x
EC313868	(2)-C22	EJ310391	2-31x	HA308686	2-18	SP308797	10-51x
EC405898	(2)-C30	EJ310392	2-32	HA308687	2-19	SP308798	10-50x
EC450270	(1)-C4	EJ310446	2-33x	HA309409	2-16	SP308799	10-53x
EC459145	(1)-C5	EM309050	9-17x	HA309410	2-17	SP308800	10-52x
EC516701	(2)-C29	EM309051	9-16	HB308681	2-9	SP308805	10-35
EC551160	6-1x	EO301448	(2)-L1	HB308685	2-13	SZ308717	5-3
EC558202	(2)-TC1,2	EO301467	(2)-L2	HB309407	2-10	SZ308718	5-5
ED224550	(1)-D51,52	EO308974	(2)-L4	HB309408	2-11	SZ308782	10-40
ED224550	(1)-D54	EO308982	(2)-L3	HE308149	2-21	SZ311866	10-22x
ED224550	(1)-D56	EO313608	(2)-L5,6	HP308146	2-23	SZ311866	10-42x
ED249377	(4)-D1,2	EP280743	(1)-RL6	HR308148	2-22	ZG301072	9-10
ED283138	7-33	EP308949	(1)-RL5	HZ301366	2-24	ZG301073	9-11
ED303005	7-34	EP308973	(2)-RL1	HZ301777	2-8	ZG301340	7-59
ED306109	(1)-D49	EP309056	7-3	HZ308709	5-21	ZG303300	2-12
ED308941	(1)-D9	EP309061	(1)-RL1to4	HL308710	5-19	ZG305657	10-26x
ED308941	(1)-D50	EP310447	7-24	HZ309411	2-20x	ZG305657	10-28x
ED308945	(1)-D1	EP310447	9-1	HZ528581	2-4	ZG308722	5-11
ED308945	(1)-D3	EP310448	7-13	MB308701	7-69	ZG308728	7-20
ED308951	(1)-D5	ER300820	(1)-CR1to14	MB308714	5-28	ZG308734	7-6
ED308952	(1)-D10,11	ER306299	(2)-R82	MB428343	7-16	ZG308787	10-24x
ED308952	(1)-D14	ER308955	(1)-R112	MB606712	7-38	ZG312399	5-23
ED308952	(1)-D17	ER308956	(1)-R111	MB606712	9-2	ZG312400	9-12
ED308952	(1)-D33,34	ER309092	(1)-R110	MC308242	7-1	ZG313099	7-67
ED308952	(1)-D36to38	ES301435	(2)-SW1	MH257477	9-13	ZG317496	4-9
ED308952	(1)-D44	ES301436	(2)-SW4	MH578957	2-5	ZG466312	2-7
ED308952	(1)-D46	ES301715	(2)-SW5	ML308707	5-16	ZG540617	4-3
ED308952	(2)-D1,2	ES306292	(2)-SW6	ML301123	9-9	ZG567685	5-15
ED308952	(2)-D4	ES308913	7-9	ML308677	7-29	ZG576314	7-30
ED308953	(1)-D12,13	ES308914	7-8	ML308737	7-28	ZG580522	7-27
ED308953	(1)-D28	ES308925	7-12	ML308783	10-41x	ZG672478	7-72
ED308953	(1)-D41,42	ES308929	5-8	ML308810	10-4x	ZS201341	10-33x
ED308953	(1)-D45	ES308983	(2)-SW3	ML308811	10-5x	ZS201778	2-28

# INDEX

Parts No.	Ref. No. & Symbol No.	Parts No.	Ref. No. & Symbol No.	Parts No.	Ref. No. & Symbol No.	Parts No.	Ref. No. & Symbol No.
ZS297641	10-54x	ZW548010	10-37				
ZS302720	7-31	ZW550697	5-10				
ZS308931	5-9	ZW575730	10-9x				
ZS309096	7-68x	ZW580173	7-66				
ZS323728	7-47	ZW597543	3-2				
ZS325495	6-12	ZW597622	3-4				
ZS325495	7-44x	ZW605698	3-3				
ZS325495	9-5	ZW625241	9-15				
ZS325495	10-29x	ZW668621	2-29				
ZS413201	2-3	ZW678723	7-14				
ZS413201	3-12						
ZS413201	7-37x						
ZS413234	10-32x						
ZS417150	7-46x						
ZS417216	5-4						
ZS417216	7-55						
ZS417407	2-15						
ZS419670	4-7						
ZS419670	7-39						
ZS421740	6-14						
ZS421806	(1)-4						
ZS422076	6-22x						
ZS422076	7-10						
ZS422076	9-3						
ZS422965	5-18						
ZS422965	10-55x						
ZS424056	4-10						
ZS435273	6-9						
ZS444262	7-23						
ZS447761	6-21x						
ZS447840	9-6						
ZS460440	2-25						
ZS463353	6-25						
ZS479474	5-22						
ZS520525	10-36						
ZS527681	7-64						
ZS592378	7-4x						
ZS608095	2-26						
ZS608308	3-6x						
ZS608321	5-14						
ZS608321	7-58x						
ZS608321	10-6x						
ZS608501	2-14						
ZS613901	10-38						
ZW260076	7-18x						
ZW263946	9-7						
ZW265522	2-6						
ZW270088	4-5						
ZW270088	7-7						
ZW270088	9-14						
ZW270101	5-13						
ZW270101	7-61x						
ZW270123	7-17						
ZW270156	7-60x						
ZW273756	7-32						
ZW273756	(1)-5						
ZW273914	2-2						
ZW273914	7-40x						
ZW274026	7-42x						
ZW290283	7-15						
ZW302896	5-7						
ZW307294	5-26						
ZW308796	10-39						
ZW308916	6-8x						
ZW308927	5-24						
ZW308928	5-29						
ZW308930	5-12						
ZW309054	7-36						
ZW309055	2-27						
ZW313593	7-5						
ZW313822	5-25x						
ZW330412	7-70x						
ZW330423	7-71x						
ZW376391	7-63						
ZW413188	7-41x						
ZW413267	6-10						
ZW413278	3-11						
ZW413278	7-22						
ZW413278	7-43x						
ZW420682	7-19						

---

SECTION 3

**SCHEMATIC DIAGRAM**

1. GX-635D/DB NO. 2-1 1562416A SCHEMATIC DIAGRAM
2. GX-635D NO. 2-2 1562417A AMP SCHEMATIC DIAGRAM

**M54410P**

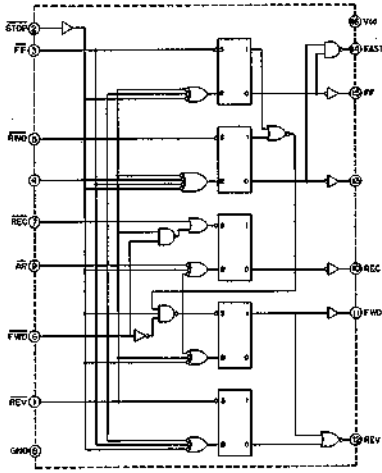

**M53200P**

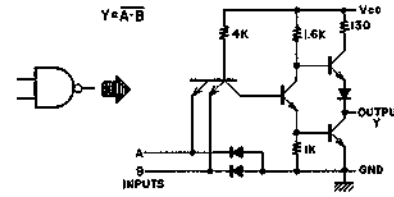
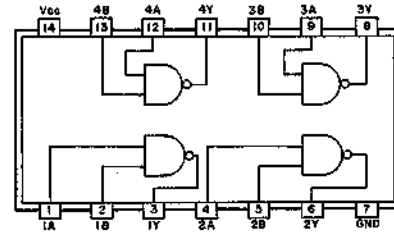

**M53202P**

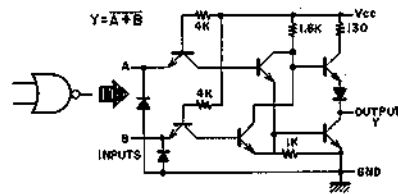
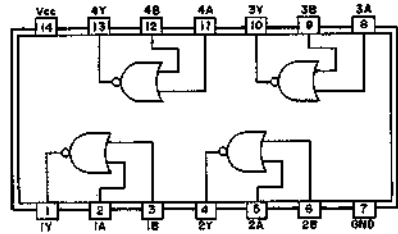

**M53204P**

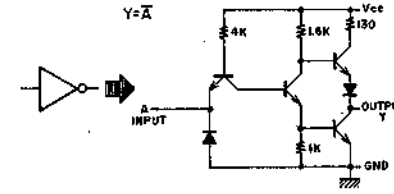
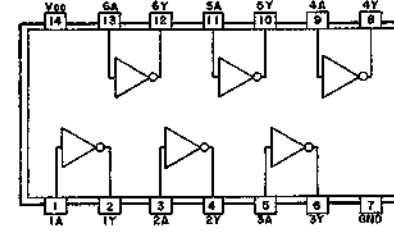

**LA4170**

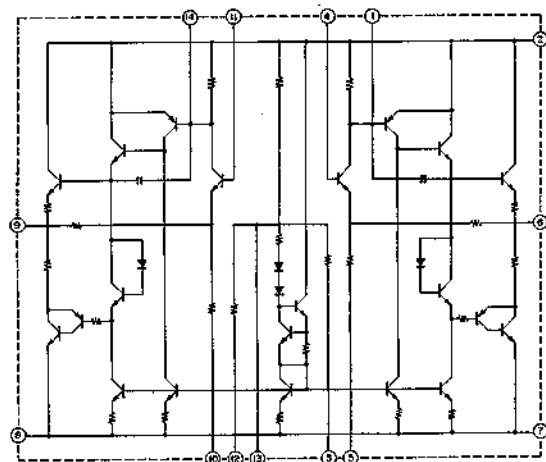

GX-635D/DB

WARNING: INDICATES SAFETY CRITICAL COMPONENTS FOR CONTINUED SAFETY. REPLACE SAFETY CRITICAL COMPONENTS ONLY WITH MANUFACTURER'S RECOMMENDED PARTS.  
AVERTISSEMENT: LES COMPOSANTS CRITIQUES DE SÛRETÉ. POUR MAINTENIR LE DEGRÉ DE SÛRETÉ DE L'APPAREIL, NE REMPLACER LES COMPOSANTS QU'AVEC LE FACTUREMENT EST CRITIQUE POUR LA SÛRETÉ QUE PAR DES PIÈCES RECOMMANDÉES PAR LE FABRICANT.

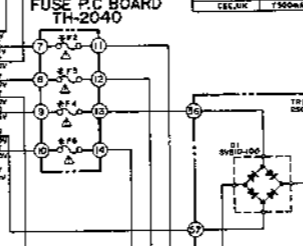
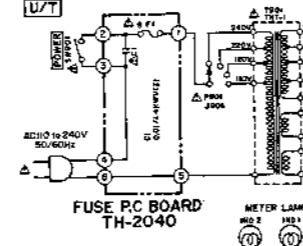
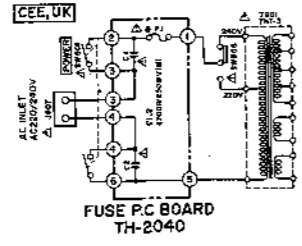
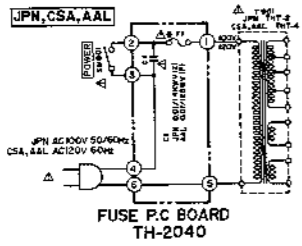

F1	F2	F3	F4	F5
1A	1A	1A	1A	1A
1A	1A	1A	1A	1A
1A	1A	1A	1A	1A
1A	1A	1A	1A	1A
1A	1A	1A	1A	1A

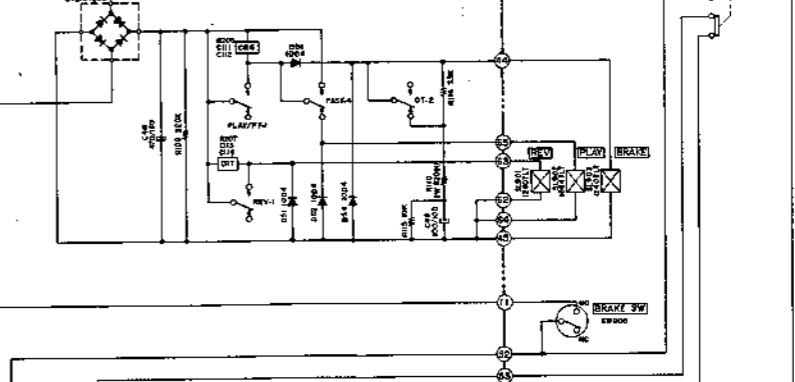
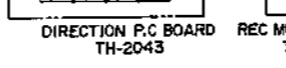
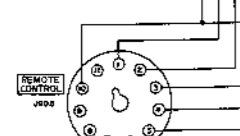
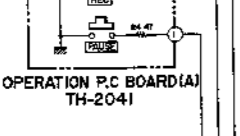
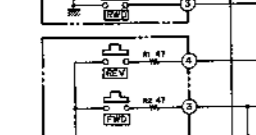
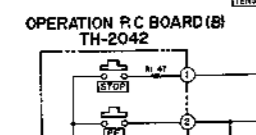
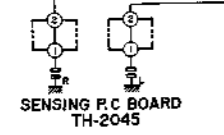
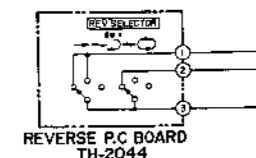
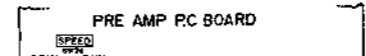

NOTE:  
USE RES OTHERWISE SPECIFIED  
ALL RESISTORS IN OHMS 1/4W 1%  
ALL CAPACITORS IN µF 50V 4.7  
POWER TRANSFORMER IS DIFFERENT ACCORDING TO AREA  
(-M-) MARK INDICATES NON POLAR CAPACITOR

GX-635D/DB  
SCHEMATIC DIAGRAM  
NO.2-1 1562416A

GX-635D

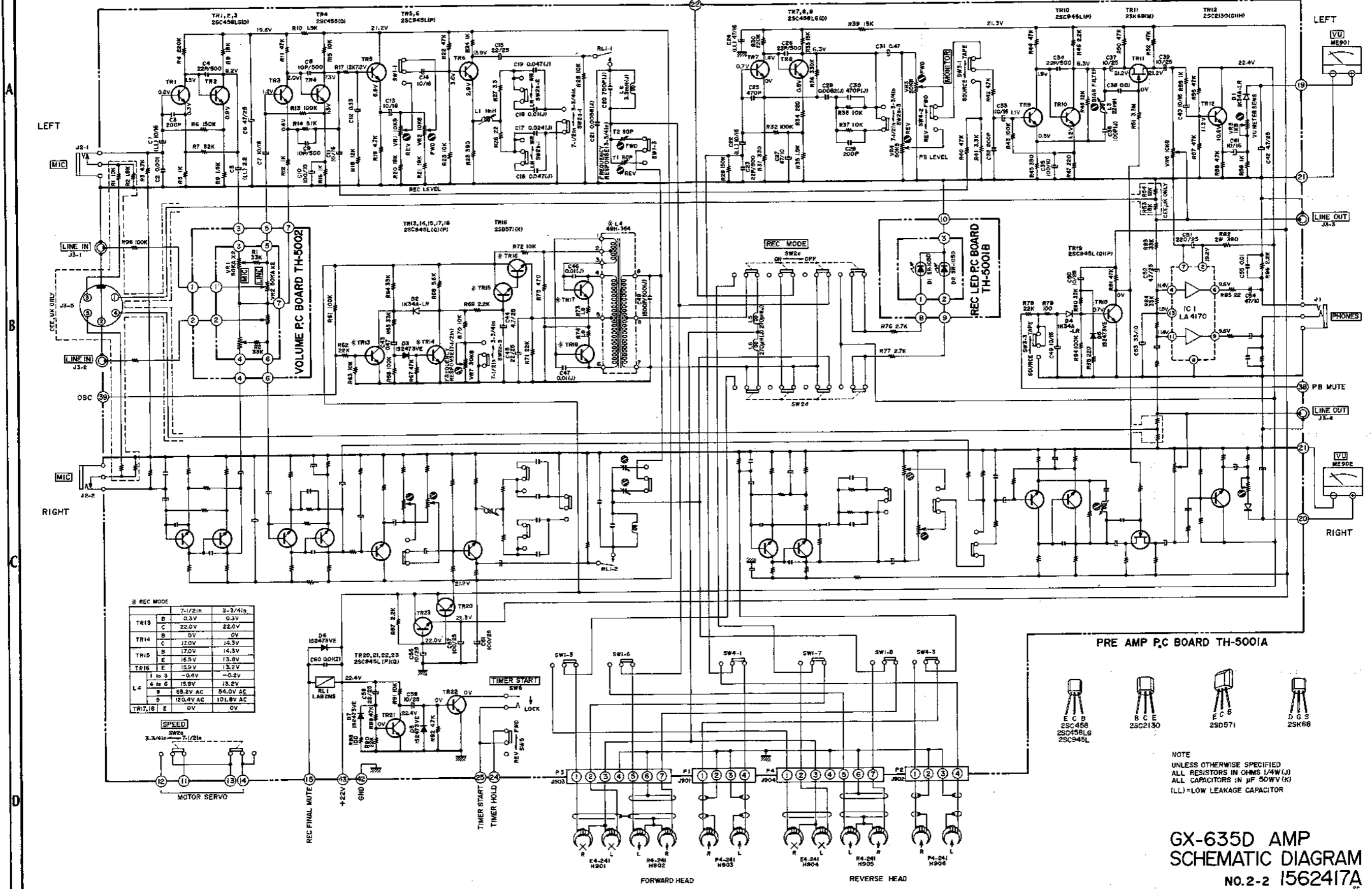

GX-635D AMP  
 SCHEMATIC DIAGRAM  
 NO.2-2 1562417A

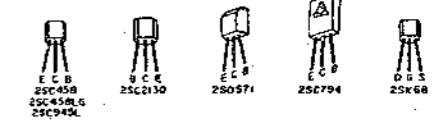
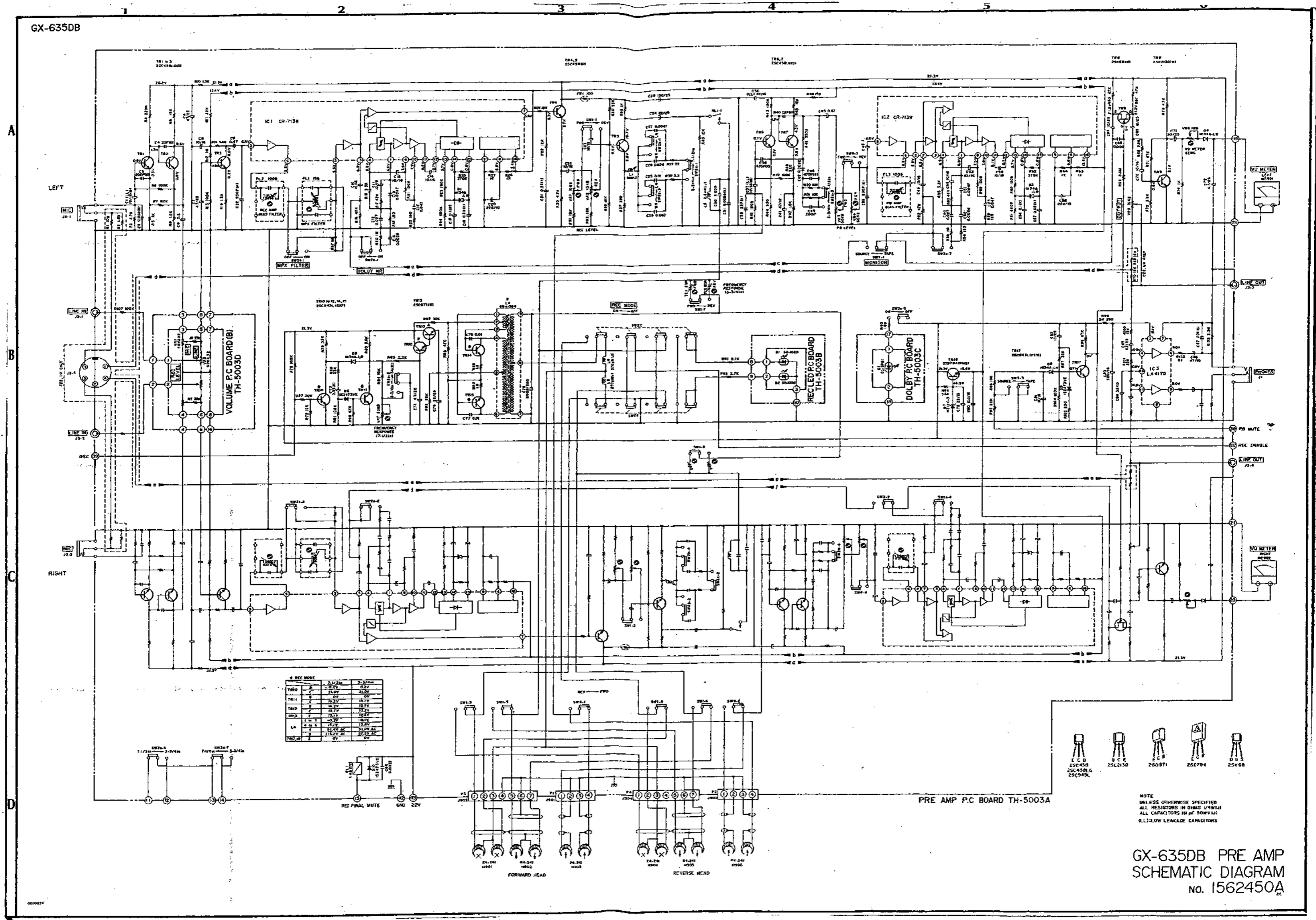

NOTE  
UNLESS OTHERWISE SPECIFIED  
ALL RESISTORS IN OHMS (1/4W/1%)  
ALL CAPACITORS IN μF (50V/5%)  
ILLUSTRATED CAPACITORS

GX-635DB PRE AMP  
SCHEMATIC DIAGRAM  
No. 1562450A



PRE AMP P.C BOARD TH-5003A (3ED), REC LED P.C BOARD TH-5003B AND DOLBY P.C BOARD TH-5003C

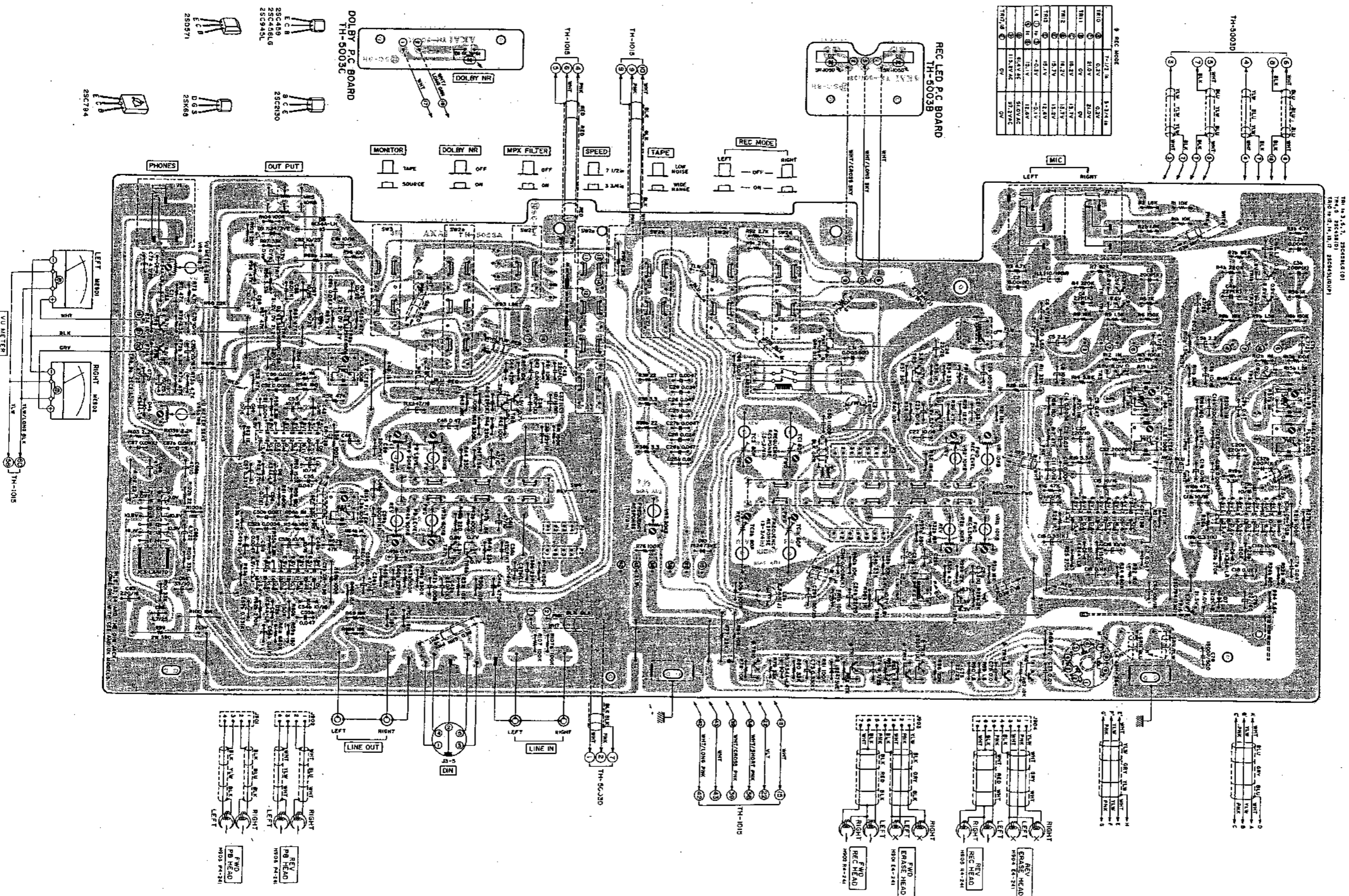

REC MODE

TH-1015	TH-1015	TH-1015	TH-1015	TH-1015	TH-1015	TH-1015	TH-1015	TH-1015	TH-1015	TH-1015
1	2	3	4	5	6	7	8	9	10	11
12	13	14	15	16	17	18	19	20	21	22
23	24	25	26	27	28	29	30	31	32	33
34	35	36	37	38	39	40	41	42	43	44
45	46	47	48	49	50	51	52	53	54	55
56	57	58	59	60	61	62	63	64	65	66
67	68	69	70	71	72	73	74	75	76	77
78	79	80	81	82	83	84	85	86	87	88
89	90	91	92	93	94	95	96	97	98	99
100	101	102	103	104	105	106	107	108	109	110

TH-5003A, 3ED (3ED)  
TH-5003B (3ED)  
TH-5003C (3ED)



**Kundendienst  
Informationen**

Akai Deutschland GmbH  
Am Siebenstein 4  
6072 Dreieich-Buchschieg  
Telefon 0 61 03/6 40 96  
Telex 04 185 332 akaid

Nr. A-09/80 Dreieich, 23.07.1980 wfs

Betr.: GX-635 D/DB

1. GX-635 D/DB

a. Zur Verbesserung der Übersprechwerte wird das genannte Gerät mit einem neuen Wiedergabekopf ausgestattet.

Alter Kopf: P 4-241 Best.-Nr. HP-308146  
Neuer Kopf: P 4-251 Best.-Nr. HP-318522

Die Köpfe sind untereinander austauschbar.

Diese Änderung wird werkseitig ab August 1979 durchgeführt.

AS-0081

b. Zur Stabilisierung des Einschaltvorganges bei "Timer"-Betrieb (Band-schlaufenbildung durch zu lockeren "Tension-arm") sind die beiden folgenden Bauteile zu ändern:

Alt: Zener-Diode WZ-120 Best.-Nr. ED-510772 ("D-51") (Steuerplatine)  
Neu: Zener-Diode WZ-130 Best.-Nr. ED-539976 ("D-51") "

Alt: Elko (Vert.-Type) 100 uF, 100 V Best.-Nr. EC-313577 ("C-491")  
Neu: Elko (Vert.-Type) 47 uF, 100 V o. Best.-Nr. ("C-491")

Diese Änderung wird werkseitig ab August 1979 durchgeführt.

AS-0081

2. GX-635 DB

Zur Verbesserung des Einstellbereiches der beidern Regler VR-1 und VR-2 dient die folgende Änderung auf der Vorverstärkerplatine:

Alt: R-31, R-32 je 18 Kohm, 1/4 Watt  
Neu: R-31, R-32 je 10 Kohm, 1/4 Watt

Alt: VR-1, VR-2, je 10 Kohm-Einstellregler (Best.-Nr. EV-305637)  
Neu: VR-1, VR-2 je 20 Kohm-Einstellregler (Best.-Nr. EV-315414)

Diese Änderung wird werkseitig ab August 1979 durchgeführt.

AS-0081