

GX-620

# AKAI SERVICE MANUAL

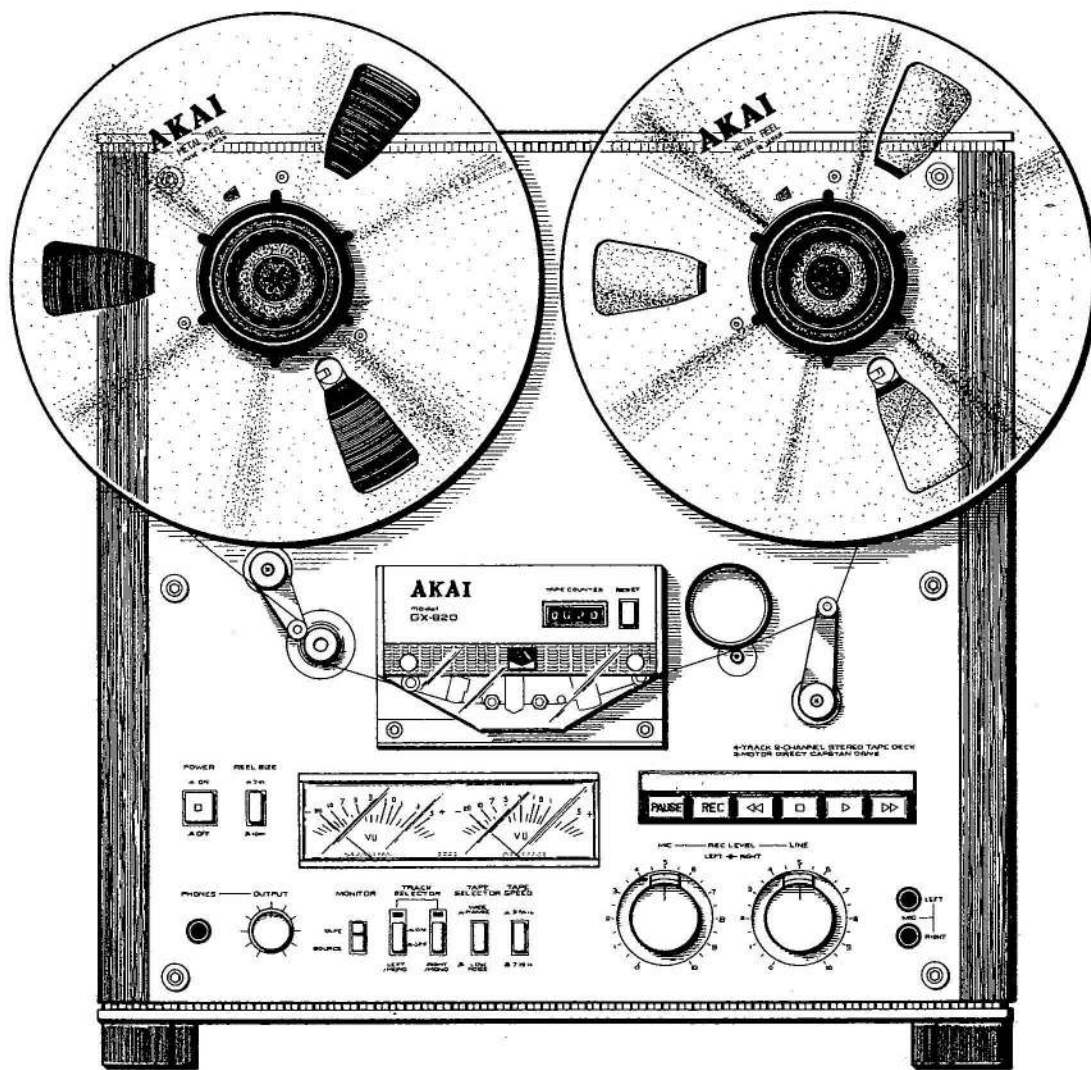

STEREO TAPE DECK

MODEL **GX-620**



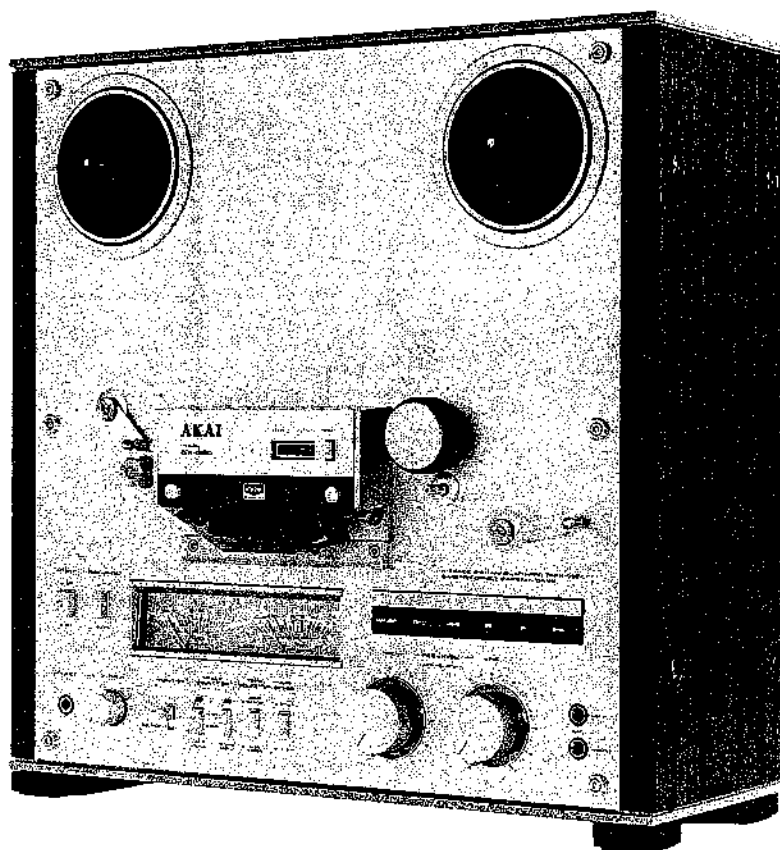

**STEREO TAPE DECK**

**MODEL GX-620**

ALSO APPLICABLE TO BLACK PANEL MODEL

SECTION 1	SERVICE MANUAL .....	3
SECTION 2	PARTS LIST .....	37
SECTION 3	SCHEMATIC DIAGRAM .....	55

---

}

---

SECTION 1

**SERVICE MANUAL**

TABLE OF CONTENTS

I.	TECHNICAL DATA .....	4
II.	DISMANTLING OF UNIT .....	5
III.	CONTROLS .....	6
IV.	PRINCIPAL PARTS LOCATION .....	8
V.	VOLTAGE AND CYCLE CONVERSION .....	10
	1. VOLTAGE CONVERSION .....	10
	2. CYCLE CONVERSION .....	11
VI.	CIRCUIT OPERATING PRINCIPLES .....	12
	1. CIRCUIT CONSTRUCTION OF IC1 M54410P .....	12
	2. THE SAMPLE AND HOLD SYSTEM SERVO MOTOR (SCM-200) OPERATION .....	14
VII.	MECHANISM ADJUSTMENT .....	17
	1. TAPE GUIDE HEIGHT ADJUSTMENT .....	17
	2. REEL TABLE HEIGHT ADJUSTMENT .....	18
	3. CAPSTAN SHAFT LOOSE PLAY ADJUSTMENT .....	18
	4. IMPEDANCE ROLLER LOOSE PLAY ADJUSTMENT .....	18
	5. BRAKE BAND POSITION ADJUSTMENT AND BRAKE TENSION ADJUSTMENT .....	19
	6. PINCH ROLLER PLUNGER INSTALLATION AND PINCH ROLLER PRESSURE ADJUSTMENT .....	20
	7. PAUSE PLUNGER POSITION ADJUSTMENT .....	20
	8. TAPE SPEED ADJUSTMENT .....	21
VIII.	HEAD ADJUSTMENT .....	22
IX.	AMPLIFIER ADJUSTMENT .....	24
X.	DC RESISTANCE OF VARIOUS COILS .....	27
XI.	CLASSIFICATION OF VARIOUS P.C BOARDS .....	28
	1. P.C BOARD TITLES AND IDENTIFICATION NUMBERS .....	28
	2. COMPOSITION OF VARIOUS P.C BOARDS .....	29

For basic adjustments, measuring methods, and operating principles, refer to GENERAL TECHNICAL MANUAL.

# I. TECHNICAL DATA

TRACK SYSTEM	4 track 2 channel stereo/monaural system
REEL CAPACITY	Up to 10-1/2" reel
TAPE SPEED	19 cm/s $\pm$ 0.8% (7-1/2 ips.) 9.5 cm/s $\pm$ 1.0% (3-3/4 ips.) (Pitch control : $\pm$ 6%) AAL Model Only
WOW & FLUTTER	Less than 0.03% WRMS, 0.08% DIN 45500 at 19 cm/s Less than 0.04% WRMS, 0.10% DIN 45500 at 9.5 cm/s
FREQUENCY RESPONSE	30 to 26,000 Hz $\pm$ 3 dB at 19 cm/s (WR Tape) 30 to 19,000 Hz $\pm$ 3 dB at 9.5 cm/s (WR Tape)
DISTORTION	Less than 0.5% (at 1,000 Hz 0VU)
SIGNAL TO NOISE RATIO	Better than 62 dB DIN 45500 at 19 cm/s
ERASE RATIO	Better than 70 dB (at 1,000 Hz)
CROSS TALK	Better than 40 dB (at 1,000 Hz)
CHANNEL SEPARATION	Better than 55 dB (at 1,000 Hz)
BIAS FREQUENCY	100 kHz
HEADS	(3): One GX recording head, One GX playback head One erase head
MOTORS	(3): One AC servo motor for capstan drive Two AC eddy current motors for reel drive
FF. & RWD. Time	120 sec. using 550 m (1,800 ft.) Tape
OUTPUT JACKS	Line (2): 0.775 V (0VU) Required load impedance: more than 20 kohms Phone (1): 100 mV/8 ohms
INPUT JACKS	Microphone (2): 0.25 mV Required microphone impedance: 600 ohms Line (2): 70 mV Input impedance 100 kohms
DIN JACK	Input: 2.0 mV Input impedance 10 kohms Output: 0.3 V
DIMENSIONS	440(W) $\times$ 446(H) $\times$ 241(D) mm (17.4 $\times$ 17.6 $\times$ 9.5")
WEIGHT	17.6 kg (38.9 lbs)
POWER REQUIREMENT	120V, 60 Hz for USA & Canada 220/240V switchable, 50 Hz for European countries & Australia 110/120/220/240V, 50/60 Hz switchable for other countries
POWER CONSUMPTION	120W

\* For improvement purposes, specifications and design are subject to change without notice.

## II. DISMANTLING OF UNIT

In case of trouble, etc. necessitating dismantling, please dismantle in the order shown in the photographs. Reassemble in reverse order.

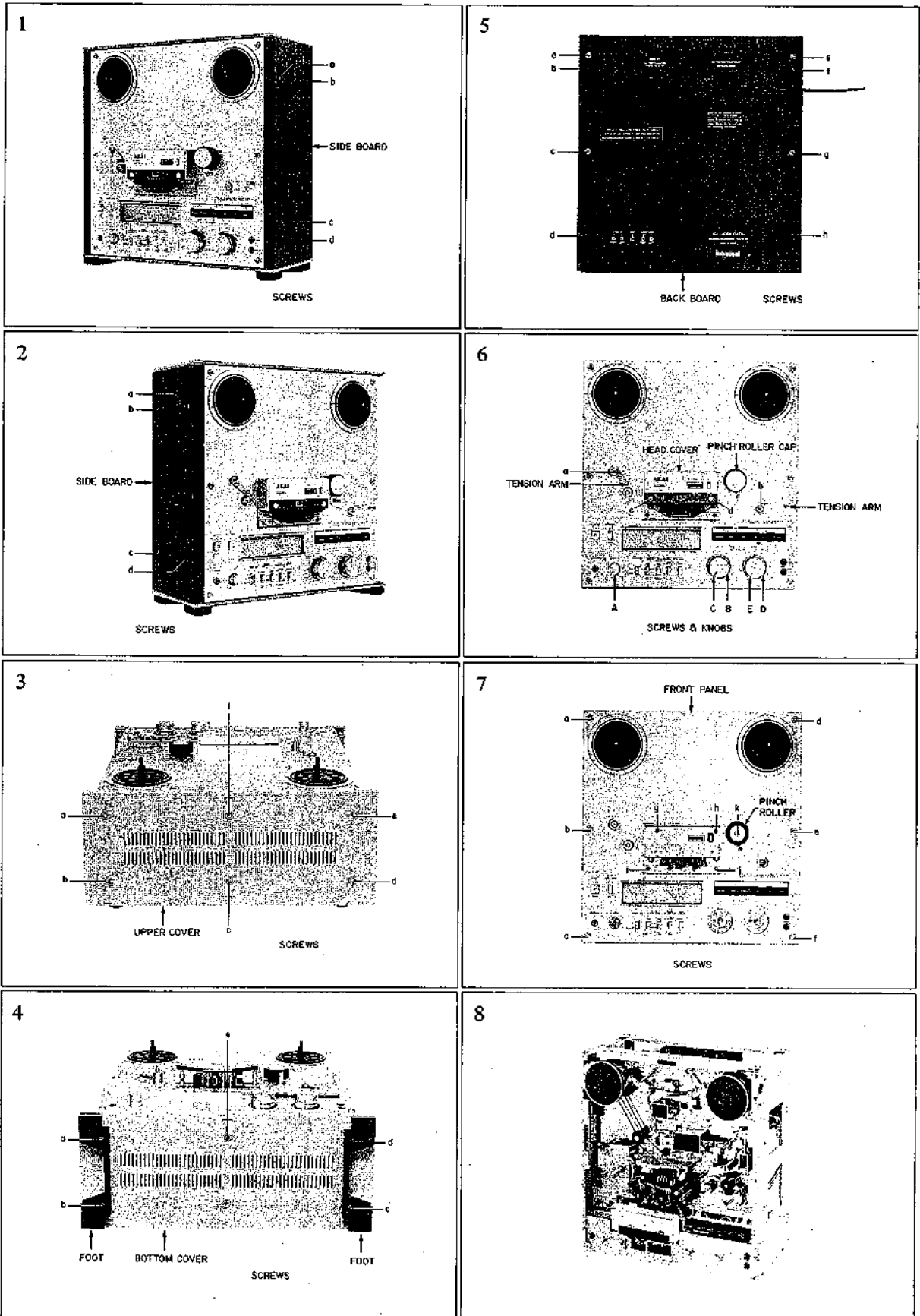

### III. CONTROLS

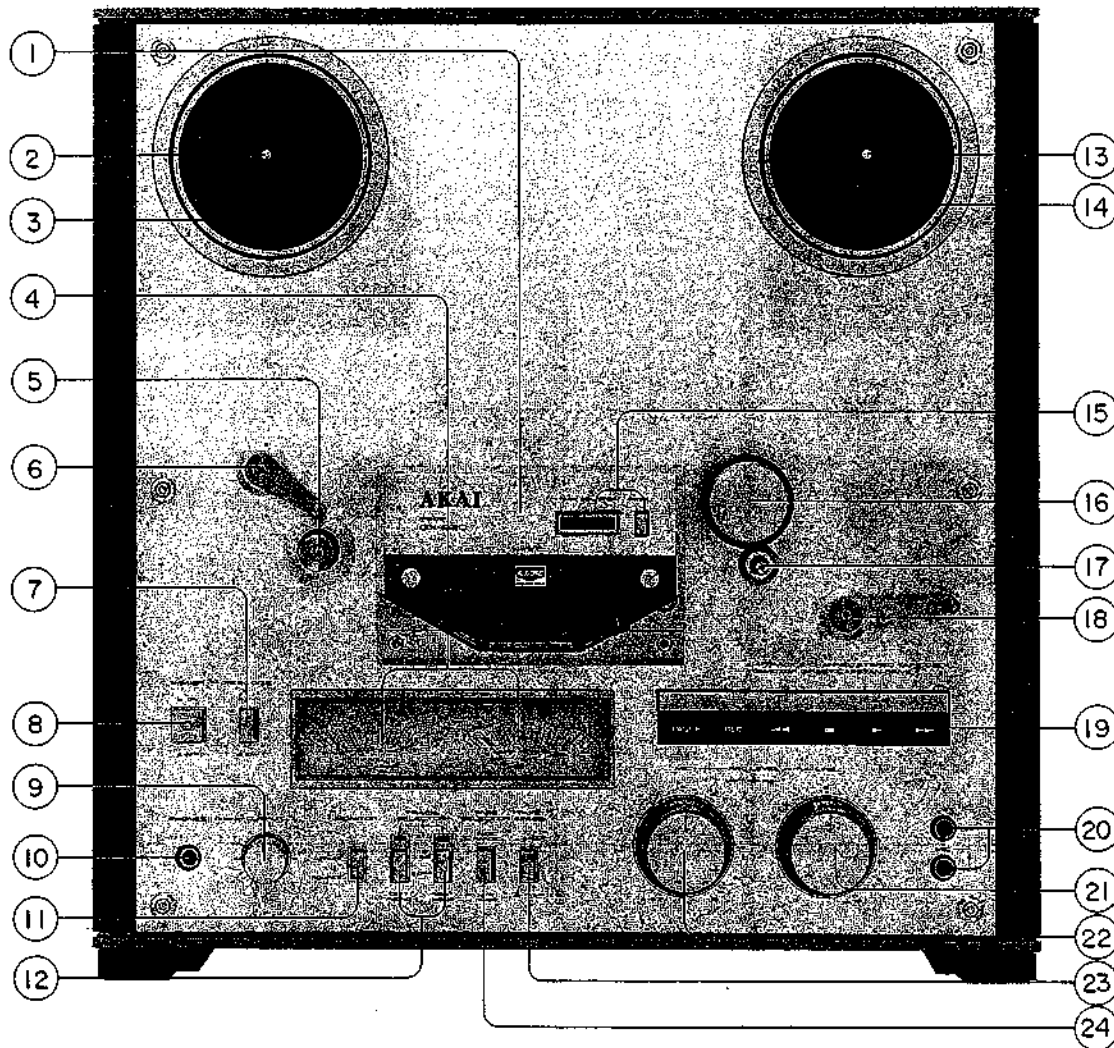

1. HEAD COVER
2. BUILT-IN REEL RETAINER (Left)
3. SUPPLY REEL TABLE
4. VU METERS (Left and Right)
5. IMPEDANCE ROLLER
6. TAPE TENSION LEVER
7. REEL SIZE SELECTOR
8. POWER SWITCH
9. OUTPUT LEVEL CONTROL
10. HEADPHONE JACK
11. TAPE MONITOR SWITCH
12. TRACK SELECTOR SWITCH

13. BUILT-IN REEL RETAINER (Right)
14. TAKE-UP REEL TABLE
15. INDEX COUNTER AND RESET BUTTON
16. PINCH ROLLER
17. CAPSTAN
18. AUTOMATIC STOP/TAPE TENSION LEVER
19. OPERATING BUTTONS
20. MICROPHONE JACKS (Left/Right)
21. MICROPHONE INPUT CONTROL
22. LINE INPUT CONTROL
23. TAPE SPEED SELECTOR
24. TAPE SELECTOR SWITCH



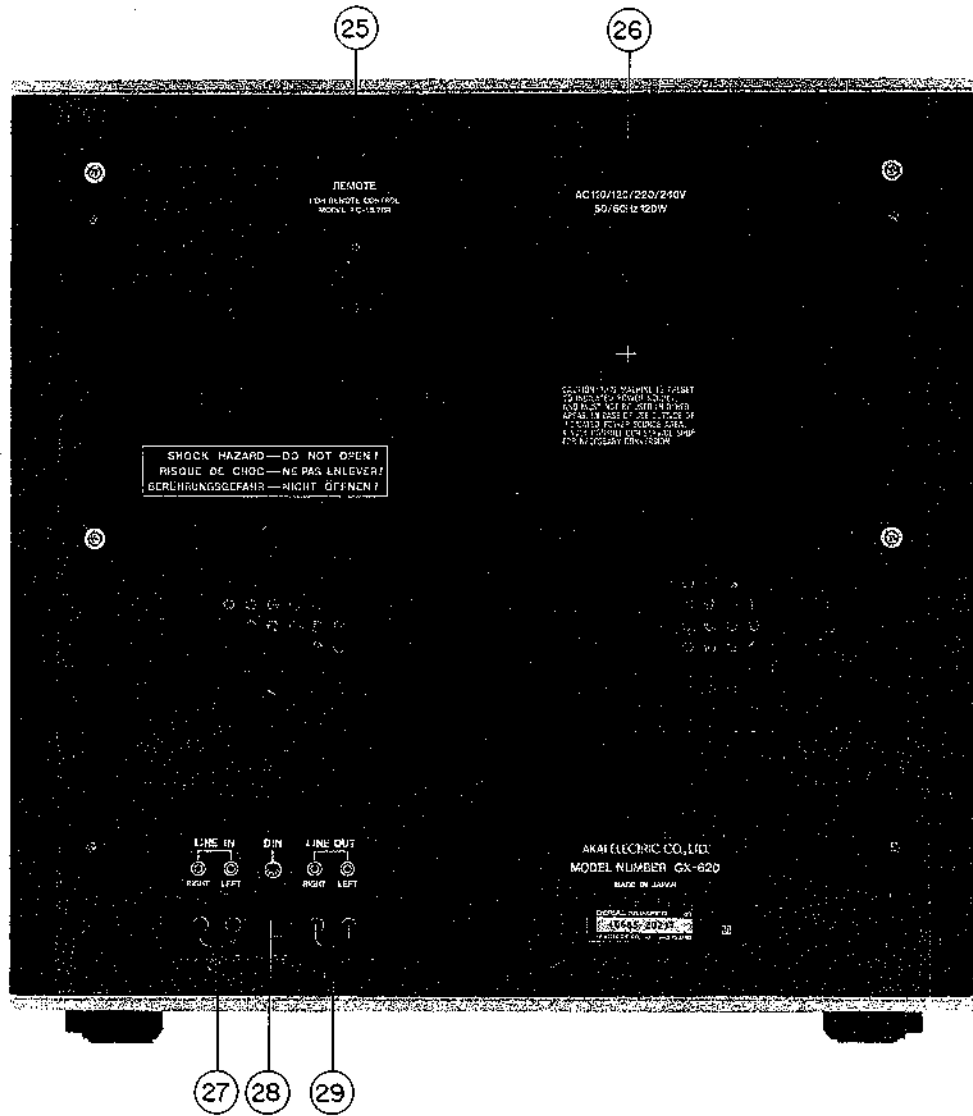

Fig. 1 Controls

- 25. REMOTE CONTROL JACK
- 26. AC CORD (AC INLET for Some Countries)
- 27. LINE INPUT JACKS (Left/Right)
- 28. DIN JACK
- 29. LINE OUTPUT JACKS (Left/Right)

# IV. PRINCIPAL PARTS LOCATION

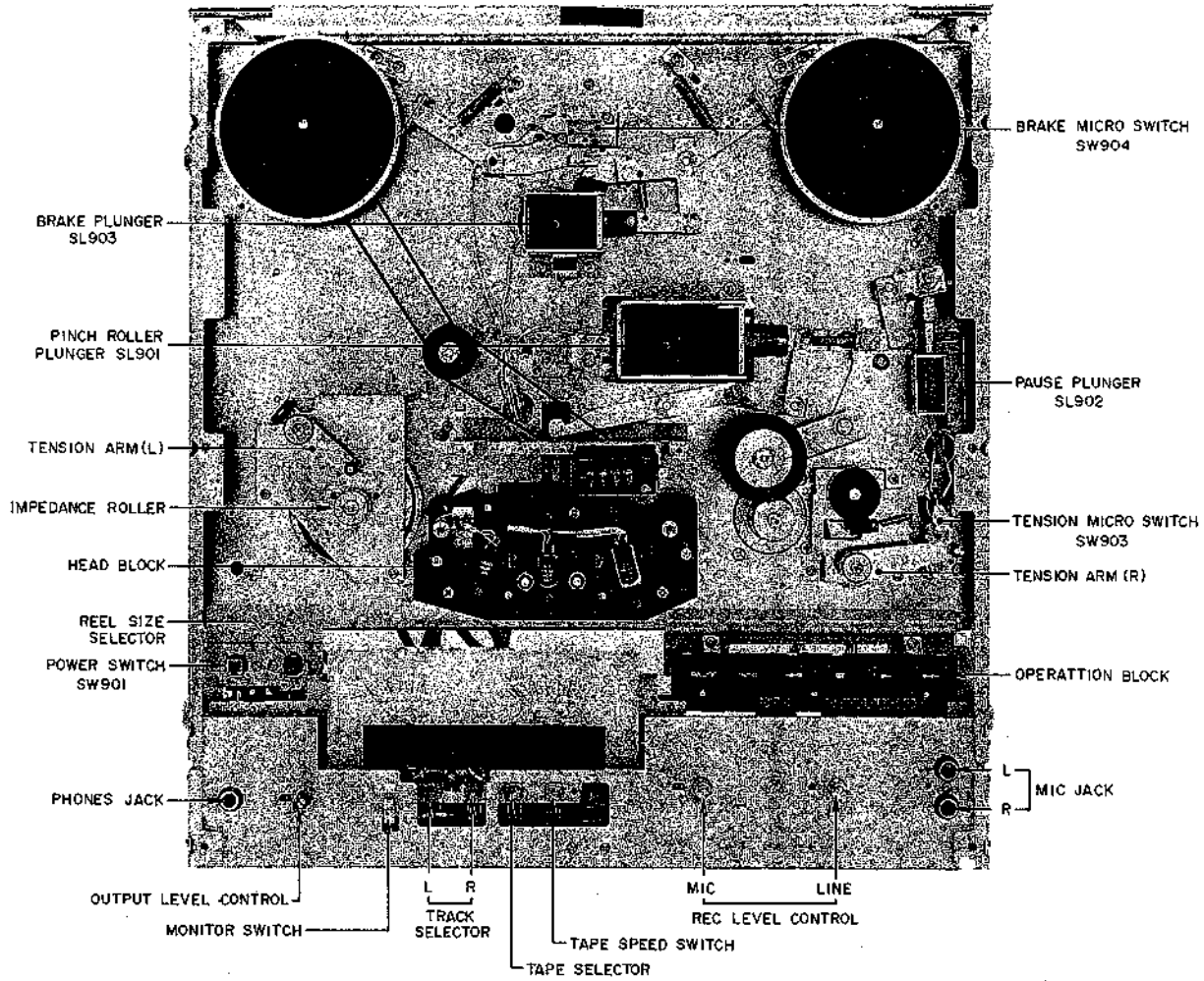

Fig. 2 Front View

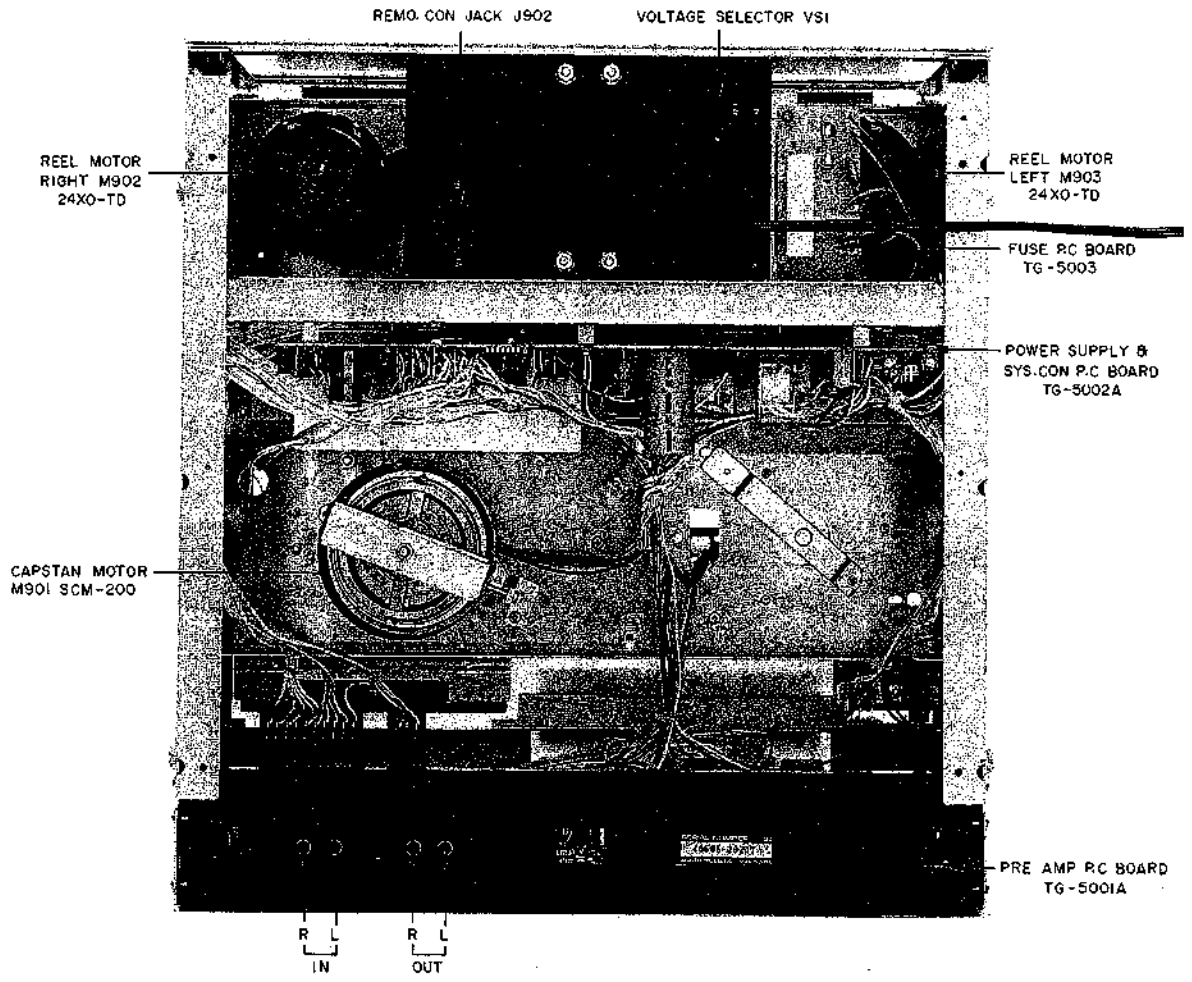
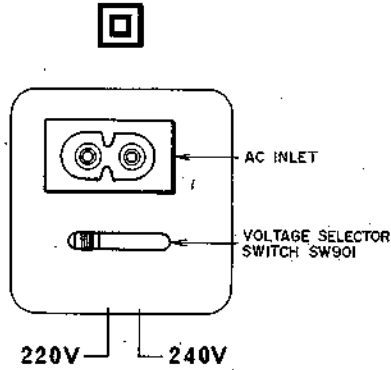

Fig. 3 Rear View

# V. VOLTAGE AND CYCLE CONVERSION

AC 220V/240V 50Hz



(a) CEE, UK Model

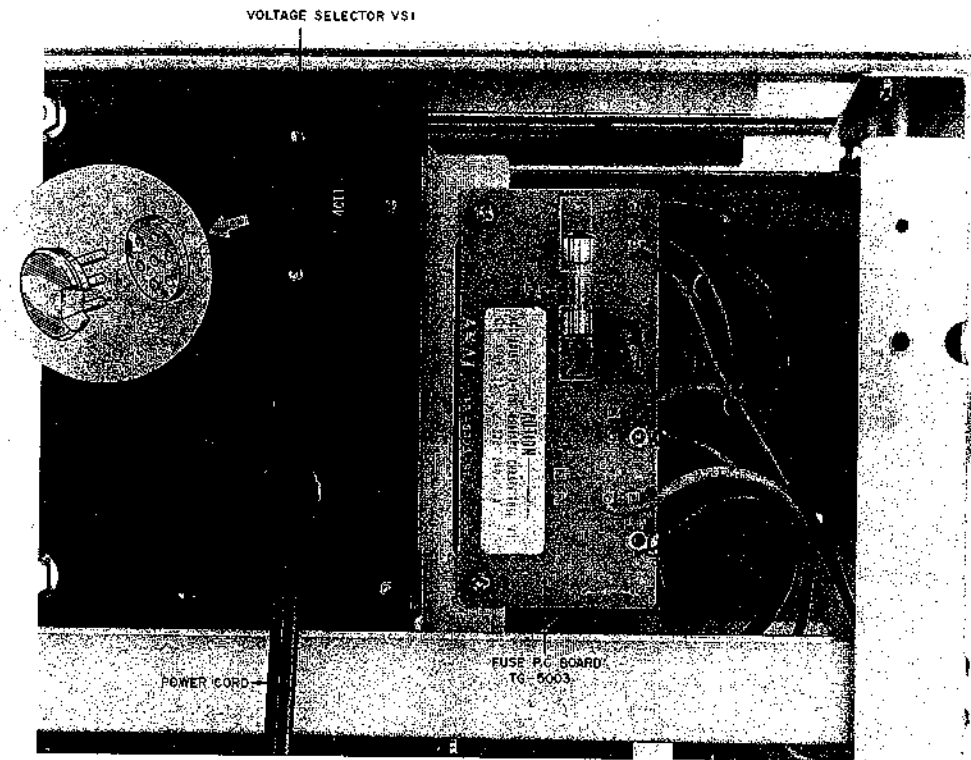

(b) U/T Model

Fig. 4 Voltage Conversion

## 1. VOLTAGE CONVERSION (Refer to Fig. 4)

### 1) CSA, AAL Model (120V, 60 Hz)

Voltage can not be switched.

### 2) CEE, UK Model (220V/240V, 50 Hz)

A voltage selector switch is provided under the AC inlet on the back side of machine. Select the proper voltage by this switch according to the voltage to be used. Move the switch to the left side for 220V and to the right side for 240V.

### 3) U/T Model (110V/120V/220V/240V, 50/60 Hz)

Remove the back board and find out the voltage selector and Fuse P.C Board on the upper right portion of the machine. Change the position of voltage selector plugs so that the voltage to be used coincides with the voltage shown through the opening of voltage selector plug. The rating of fuse (F1) differs depending on the voltage to be use. Change the fuse according to the specified rating shown below.

110V/120V Area	250V 2A
220V/240V Area	250V 1A

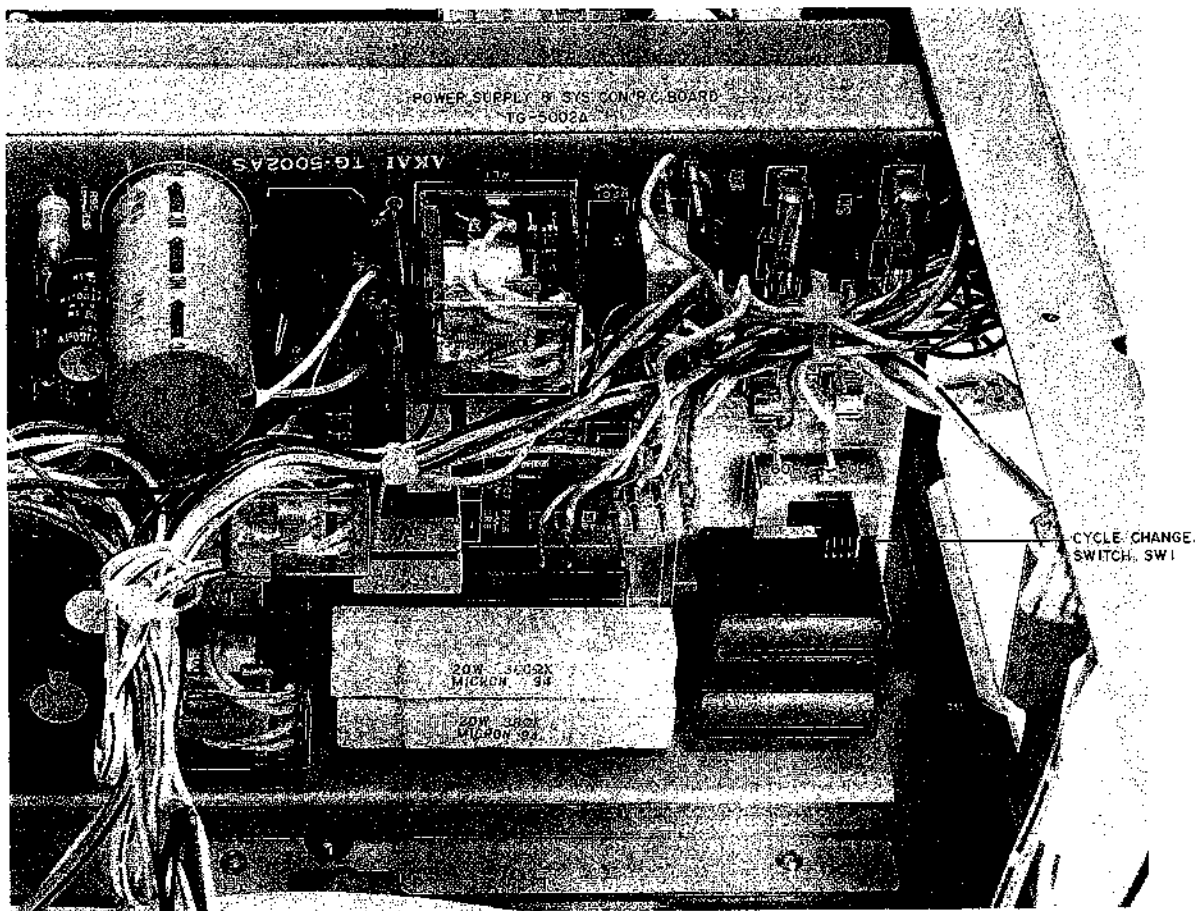

Fig. 5 Cycle Conversion (U/T Model Only)

## 2. CYCLE CONVERSION (Refer to Fig. 5)

Cycle conversion can be made only with U/T Model. Remove the back board and select the position of switch located in the recess at right portion of Power Supply & Sys. Con P.C Board in conformity with the frequency of power to be used.

Move the switch to the right for 50 Hz and to the left for the 60 Hz.

**CAUTION:** When selecting the voltage or cycle, make sure to turn off the power switch and disconnect the power cord.

# VI. CIRCUIT OPERATING PRINCIPLES

## 1. CIRCUIT CONSTRUCTION OF IC1 M54410P

This logic IC has been developed for an operation key that will maintain a HIGH output level by even a momentary low level in the desired input terminal.

### 1) Block Diagram

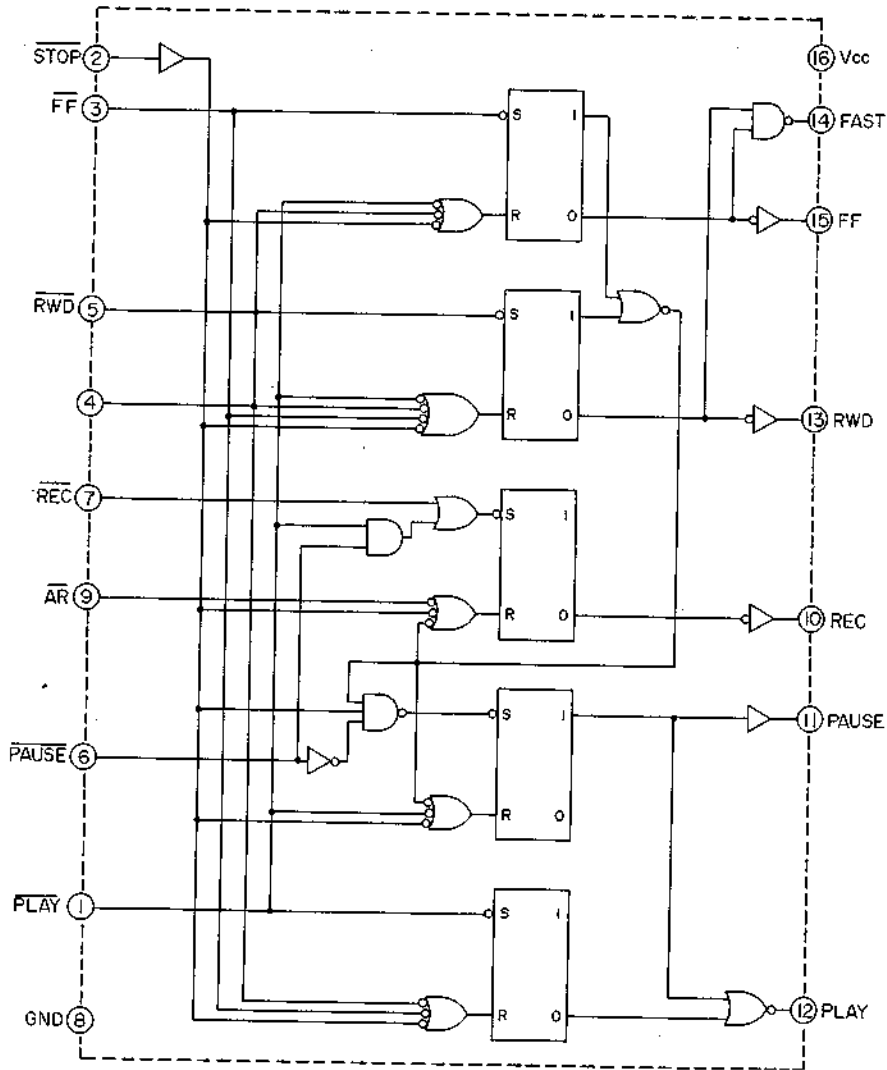

Fig. 6 M54410P

## 2) Terminals and their functions

	Terminal Name	Terminal Function
Operation input terminals	$\overline{\text{STOP}}$	Input terminal for stopping operation
	$\overline{\text{FF}}$	Input terminal for fast forward
	$\overline{\text{RWD}}$	Input terminal for rewind
	$\overline{\text{REC}}$	Input terminal for recording
	$\overline{\text{PAUSE}}$	Input terminal for pause
	$\overline{\text{PLAY}}$	Input terminal for playback
Control input terminal $\overline{\text{AR}}$		Input terminal for preventing recording
Output terminals	FAST	Terminal with "H" signal output during fast forward or rewind mode
	FF	Terminal with "H" signal output during fast forward mode
	RWD	Terminal with "H" signal output during rewind mode
	REC	Terminal with "H" signal output during REC/PLAY or REC/PAUSE mode
	PAUSE	Terminal with "H" signal output during pause mode
	PLAY	Terminal with "H" signal output during playback mode

Chart-1

## 3) Operation activated by each input

Input Signal	Output						Output Mode
	FAST	FF	RWD	REC	PAUSE	PLAY	
$\overline{\text{STOP}}$	L	L	L	L	L	L	STOP Mode
$\overline{\text{FF}}$	H	H	L	L	L	L	FF Mode
$\overline{\text{RWD}}$	H	L	H	L	L	L	RWD Mode
$\overline{\text{PLAY}}$	L	L	L	L	L	H	PLAY Mode
$\overline{\text{PAUSE}}$	L	L	L	L	H	L	PAUSE Mode
$\overline{\text{REC/PLAY}}$	L	L	L	H	L	H	REC/PLAY Mode
$\overline{\text{REC/PAUSE}}$	L	L	L	H	H	L	REC/PAUSE Mode

Chart-2

- NOTES:**
1. The input signal is activated by the fall of  $\square$ .
  2. The output is maintained until the next input signal.
  3.  $\overline{\text{AR}}$  is a control input terminal and the REC output is not "H" when  $\overline{\text{AR}} = \text{"L"}$ .
  4. When  $\overline{\text{AR}} = \text{"L"}$  signal is supplied during the REC output is "H", REC output becomes "L".
  5. At the moment the power is on, all output will be "L" and the Stop mode will be effected.

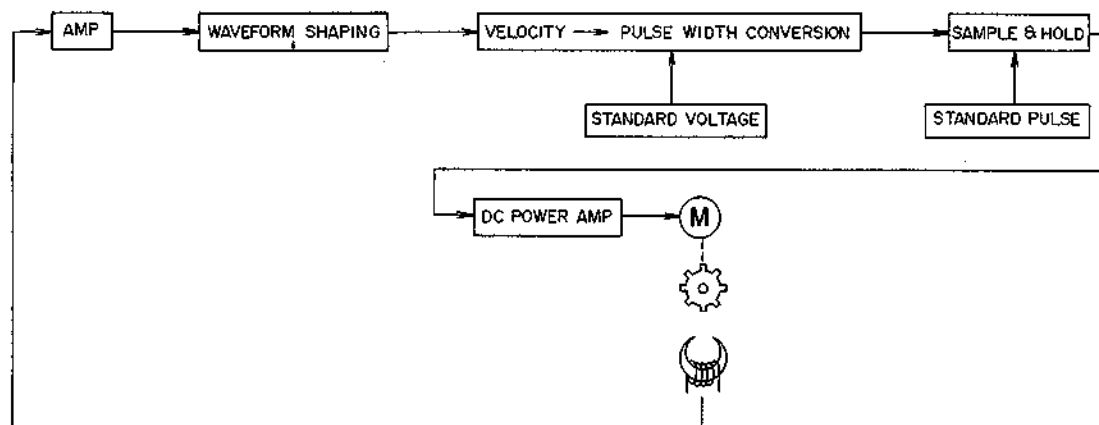

Fig. 7 Block Diagram

## 2. THE SAMPLE AND HOLD SYSTEM SERVO MOTOR (SCM-200) OPERATION

- 1) Servo signals generally created proportionately to the number of revolutions of the motor are shown either as frequency deviations or voltage deflections. The motor employed in GX-620 uses frequency deviation unaffected by time constants, etc., of the load circuit as input signal to the motor drive circuit through pulse width conversion.

This pulse width varies proportionately to the deviations in the number of motor rotations. The deviation is detected, converted to a voltage value, is held at that voltage until the next servo signal pulse, and then impressed into the motor drive circuit.

Meanwhile, since it requires a holding circuit and because 112 pulse are generated for each motor rotation, time constants of circuits coming before the Sample and Hold circuit can be greatly reduced compared to the conventional voltage deflection detection system.

For the reasons above, it features quick response to motor revolutions, minimum influence by temperature, and fewer chances of faulty mechanism. In addition, due to the inclusion of the servo voltage holding circuit, ripple content of the servo voltage has been sharply reduced to result in a smooth and stable tape transport with a minimum of wow & flutter.



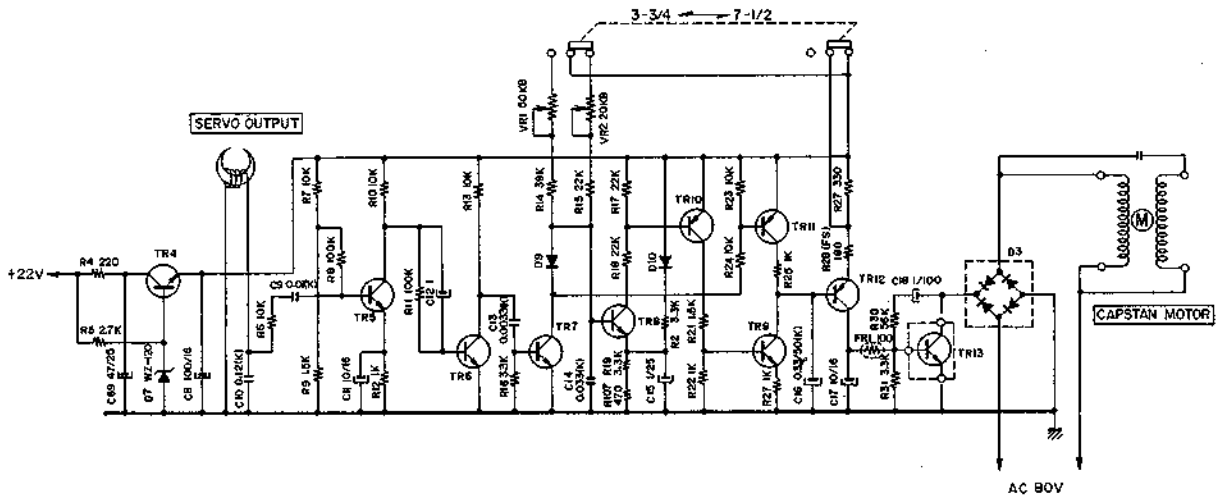

Fig. 8

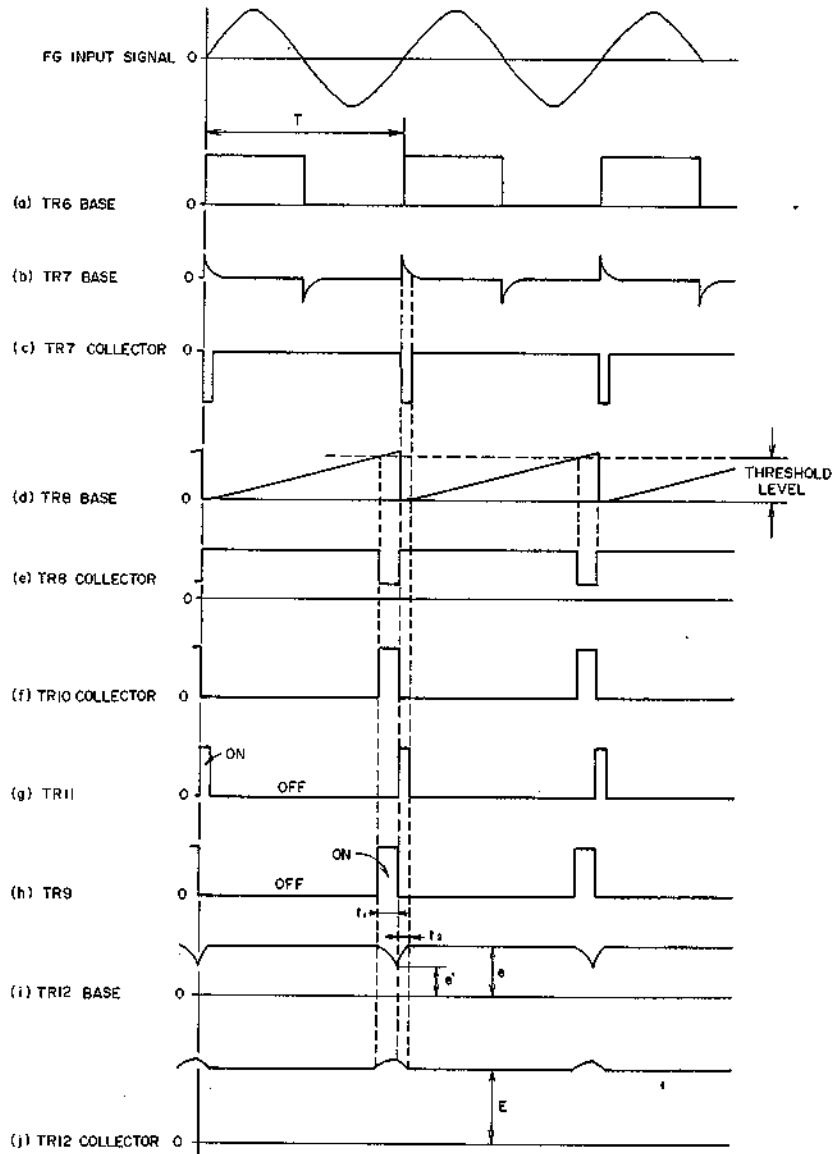

Fig. 9

---

## 2) Explanation of the circuit operation

(Refer to Figs. 8, 9)

The velocity signal obtained from the motor's frequency generator is shaped into a waveform in the period of "T" proportionate to the velocity as in (a) on collector TR6. This signal is differentiated and enters TR7 base. This makes TR7's collector output as in (c) and turns ON TR11 during the time of the negative pulse.

Meanwhile TR8 base is supplied with a waveform like (d) and when it reaches the threshold level, TR8 is turned on. A waveform (e) with pulse width " $t_1$ " is obtained from the collector. During the time "T" that TR8 is ON, TR10 base electric potential decreases to turn ON.

Consequently, TR9 base electric potential increases and TR9 is also turned ON for the time " $t_1$ ".

When the period "T" varies with the velocity, the pulse width " $t_1$ " varies according to TR8's threshold level. But when TR11 is on, it is constant due to the time constant. So that by using the period that TR11 is ON as the standard pulse, the pulse width " $t_2$ " is constant regardless of the velocity.

(g) and (h) show the ON and OFF condition of TR11 and TR9.

When the electric charge that was charged to C16 is discharged during the time TR9 is ON " $t_1$ ", a signal voltage of "e" proportionate to the velocity can be obtained. Next, with "e" as its basis, C16 is charged during the limited time of the standard pulse width " $t_2$ ", and by the charging voltage "e" the charging is stopped. The voltage is then held until the next standard pulse.

This voltage "e" is supplied to the TR12 base and a servo signal "E" is obtained. This servo signal "E" controls TR13 and drives the motor. As shown above, since " $t_1$ " and " $t_2$ " are small, servo signal ripples are made small and a near direct current servo signal is obtained.

In addition, the time constants of the smoothing circuit can also be made small that phase lag factor can be minimized.

## VII. MECHANISM ADJUSTMENT

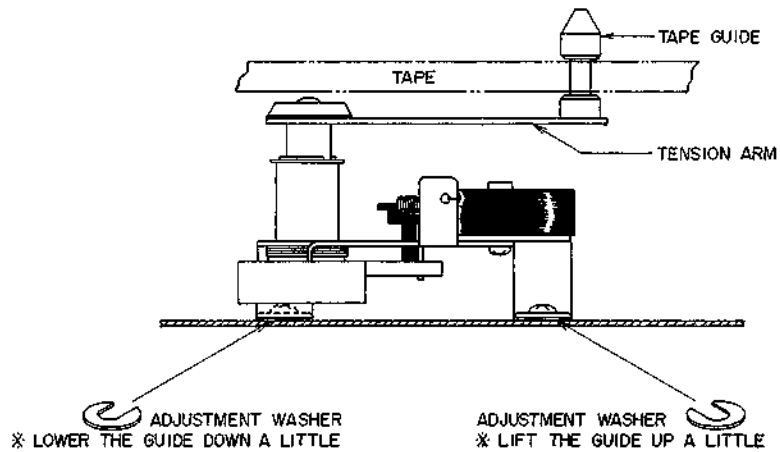

Fig. 10

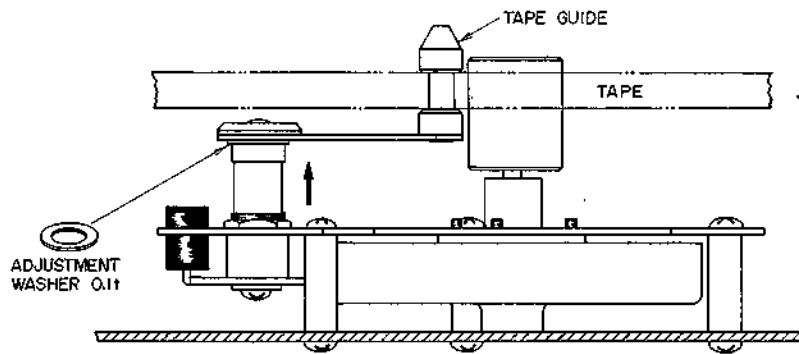

Fig. 11

### 1. TAPE GUIDE HEIGHT ADJUSTMENT

(Refer to Figs. 10, 11)

Adjust tape guide height so that the tape does not curl between the tape guide and guides on head base. As left and right tape guide height adjustment methods are different, be sure to refer to Figs. 10 and 11.

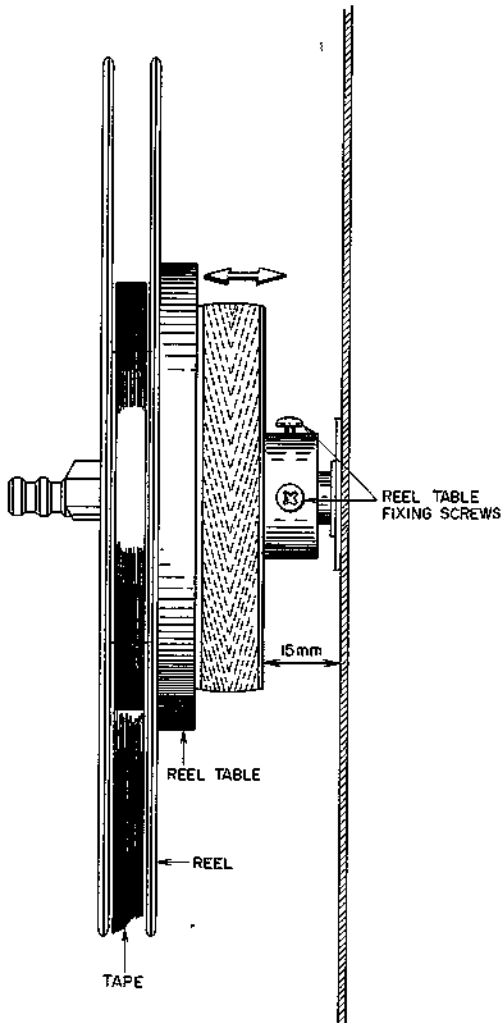

Fig. 12

## 2. REEL TABLE HEIGHT ADJUSTMENT

(Refer to Fig. 12)

- 1) Temporarily screw in the fixing screws leaving a gap of 15 mm between the reel table and the chassis board.
- 2) Run the tape and adjust the height of the reel table so that the tape is taken up in the center of the reel. Tighten fixing screws. Adjust the height of the right reel table at fast forward, of the left reel table at rewind.

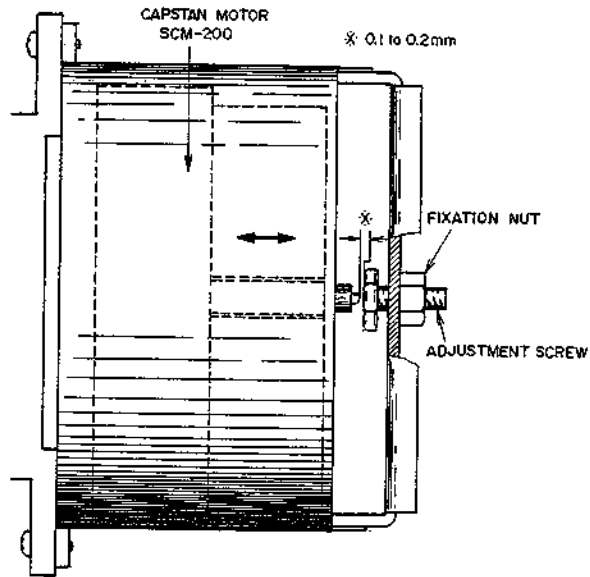

Fig. 13

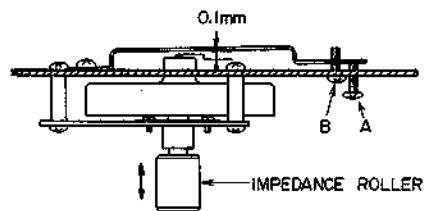

Fig. 14

## 3. CAPSTAN SHAFT LOOSE PLAY

ADJUSTMENT (Refer to Fig. 13)

Adjust by turning Adjustment Screw to obtain a 0.1 to 0.2 mm degree of loose play when the capstan shaft is moved as indicated by the arrow mark. Tighten fixation nut to maintain optimum adjusted condition.

## 4. IMPEDANCE ROLLER LOOSE PLAY

ADJUSTMENT (Refer to Fig. 14)

Adjust Screws A and B so that impedance roller loose play is 0.1 mm. Confirm that the screws are tight following this adjustment.

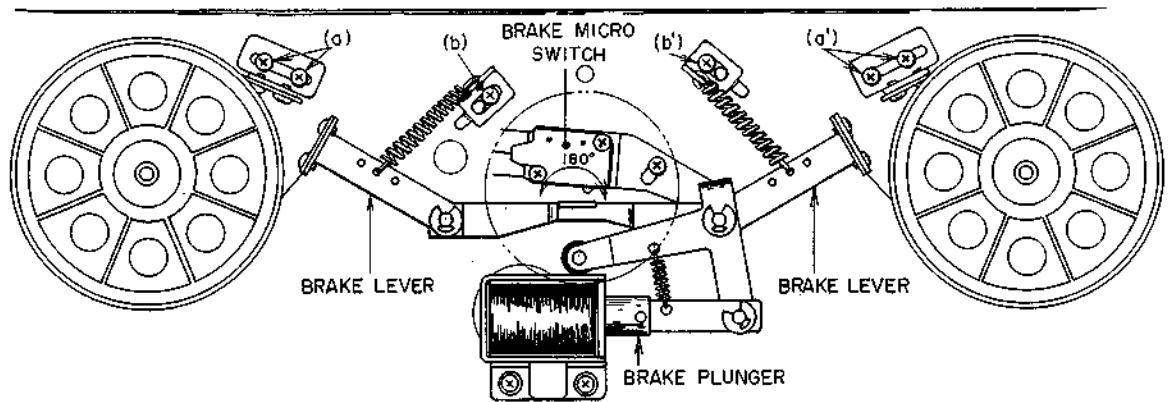

Fig. 15

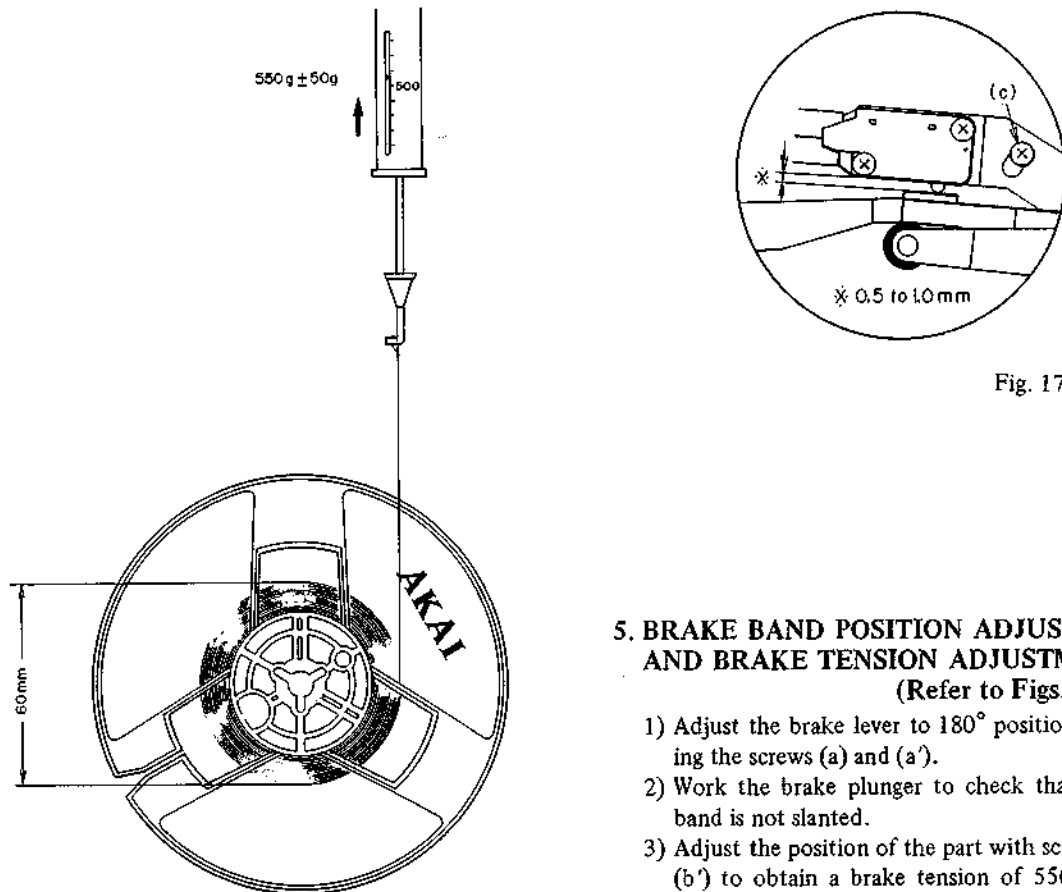

Fig. 17

Fig. 16

### 5. BRAKE BAND POSITION ADJUSTMENT AND BRAKE TENSION ADJUSTMENT

(Refer to Figs. 15 to 17)

- 1) Adjust the brake lever to 180° position by loosening the screws (a) and (a').
- 2) Work the brake plunger to check that the brake band is not slanted.
- 3) Adjust the position of the part with screws (b) and (b') to obtain a brake tension of  $550 \pm 50$  g on both brakes at stop mode.  
(Use a 1,000 g spring gauge for a reel with 60 mm diameter of tape) In case the specified brake tension cannot be obtained, connect the springs to the other holes on the brake lever and adjust.
- 4) By working the brake plunger with a finger, adjust the position of the microswitch screw (c) so that the gap between the brake lever and the micro-switch body is 0.5 to 1.0 mm.

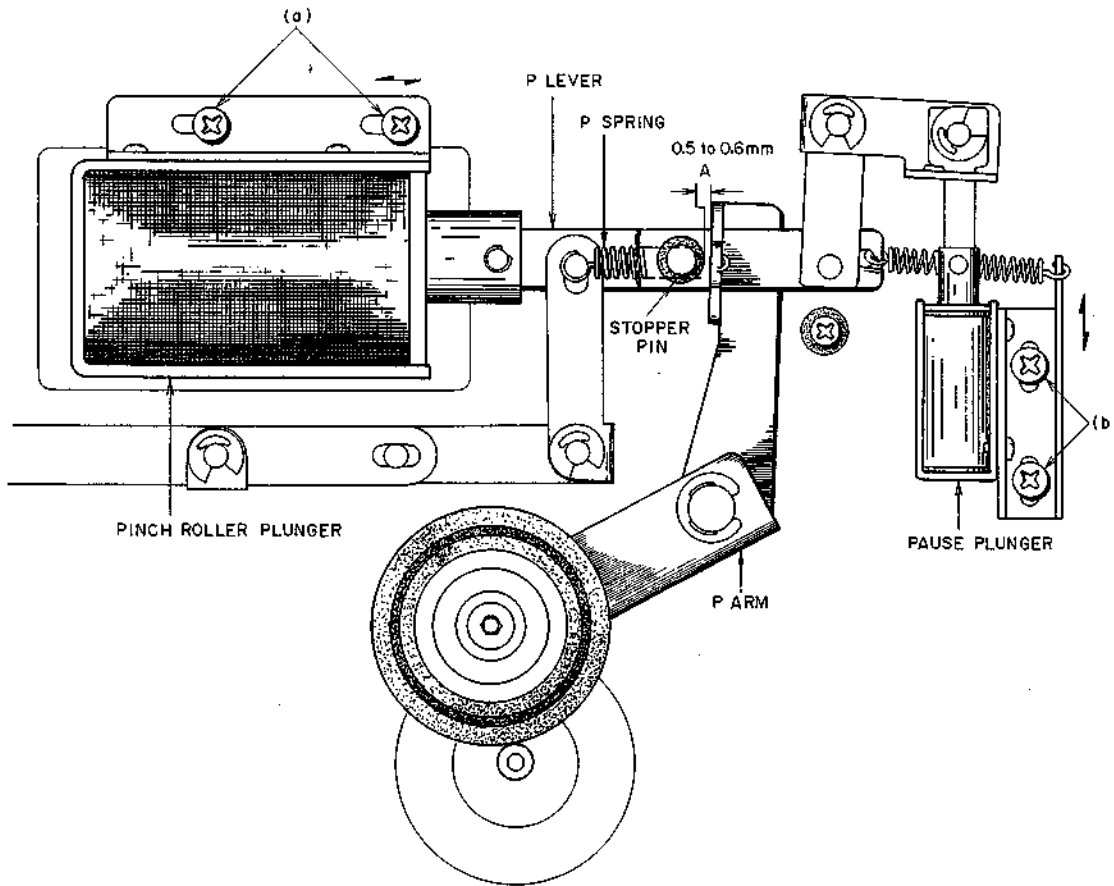

Fig. 18

## 6. PINCH ROLLER PLUNGER INSTALLATION POSITION AND PINCH ROLLER PRESSURE ADJUSTMENT

(Refer to Fig. 18)

- 1) While in the play mode, adjust the position of pinch roller plunger by means of screw (a) until the gap (Fig. 18A) between P arm and the rubber part of stopper pin becomes 0.5 to 0.6 mm.
- 2) Connect a 2 kg spring gauge to the pinch roller fixing screw. Pull up the pinch roller and then let it slowly move back. Check that the spring gauge reads  $1.2 \text{ kg} \pm 100 \text{ g}$  at the moment the pinch roller touches the capstan and starts rolling. If the specified pressure cannot be obtained, adjust gap A by positioning the pinch roller plunger or replace the P spring, so as to attain the specified pressure.

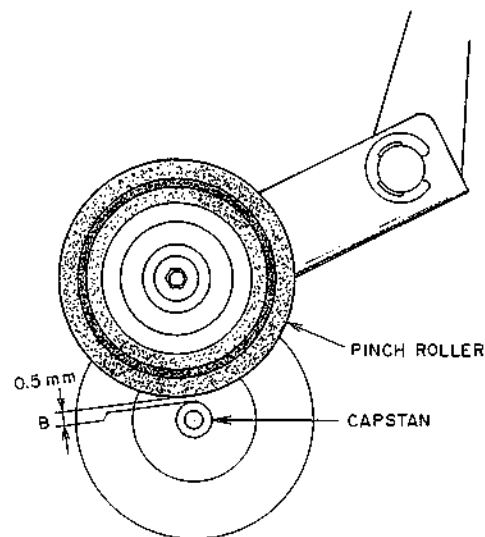

Fig. 19

## 7. PAUSE PLUNGER POSITION ADJUSTMENT (Refer to Figs. 18, 19)

At the pause mode, the gap between the capstan and the pinch roller should be 0.5 mm. Adjust the pause plunger position with screws (b).

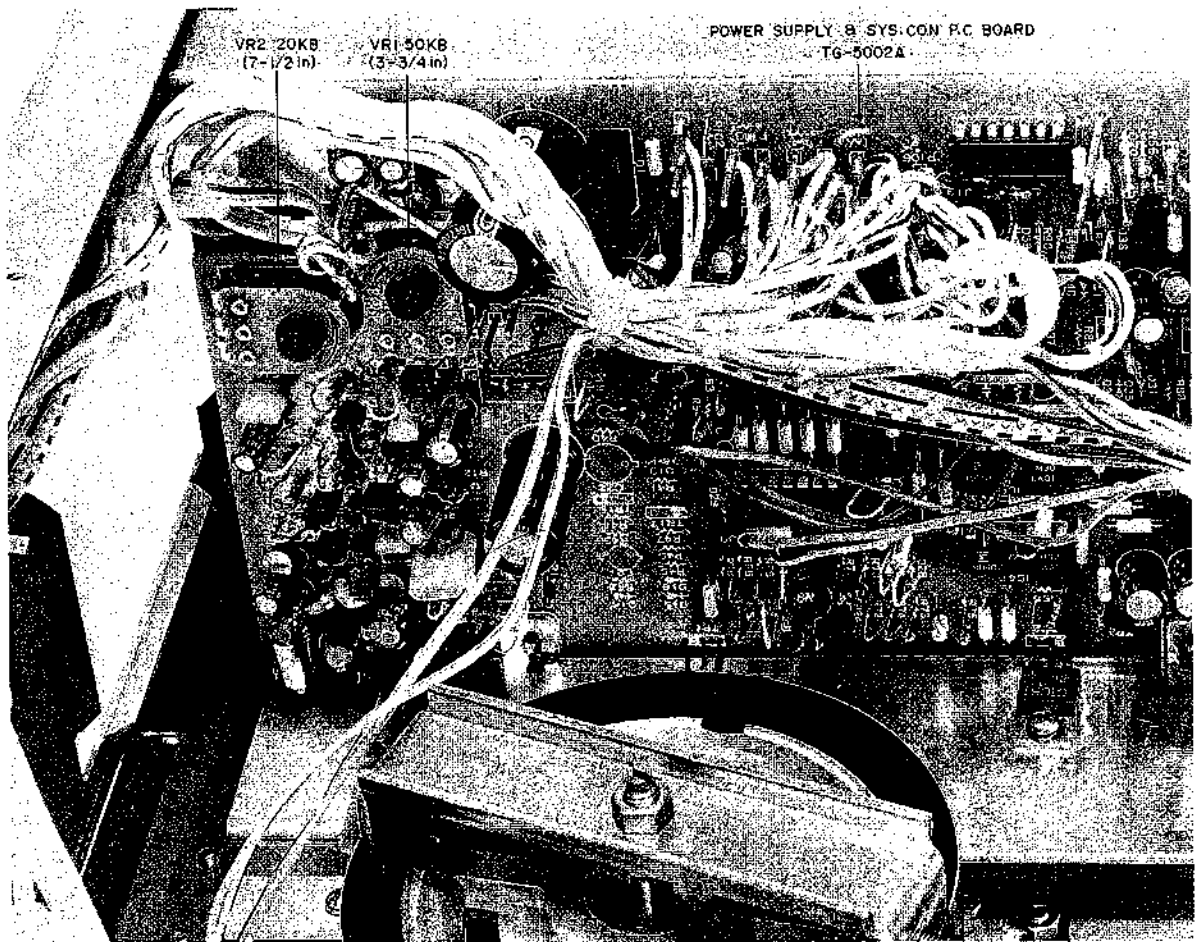

Fig. 20

## 8. TAPE SPEED ADJUSTMENT

(Refer to Fig. 20)

Set the Tape Speed Switch to 7-1/2 ips and playback the 1,000 Hz, 7-1/2 Test tape. Connect a frequency counter to LINE OUT and adjust VR2 20 kB until the counter reads 1,000 Hz  $\pm$  0.5%.

Next, set the Tape Speed Switch to 3-3/4 ips and adjust VR1 50 kB until the frequency counter reads 500 Hz  $\pm$  0.5%.

# VIII. HEAD ADJUSTMENT

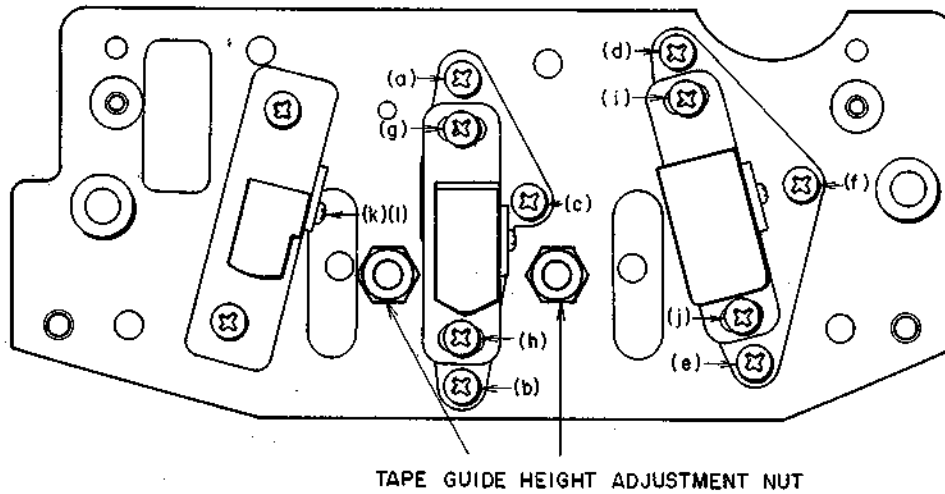

Fig. 21

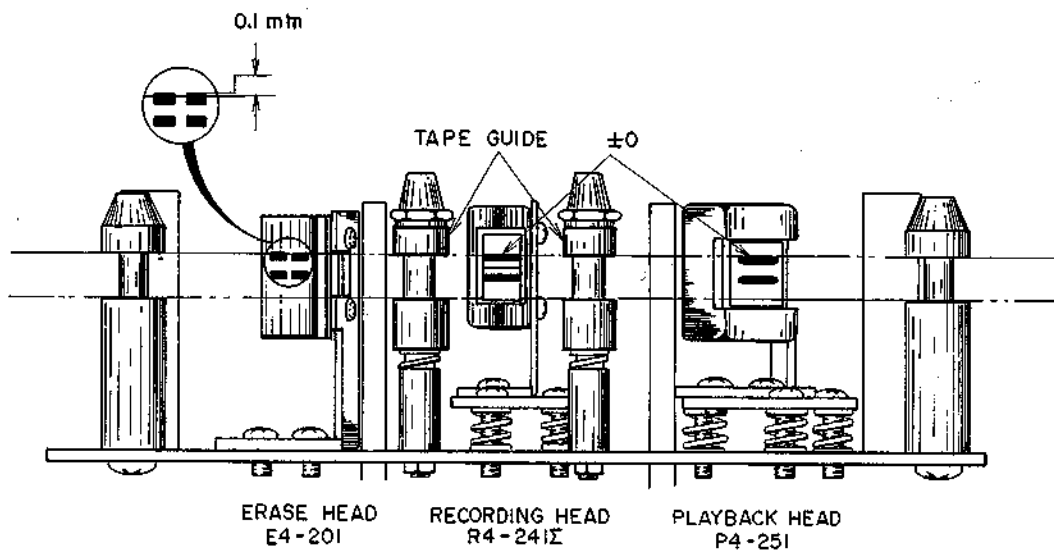

Fig. 22



Step	Adjustment Item	Test Tape Supply Signal	Mode	Adjustment Point	Remarks
1	Tape Guide Height	Optional	Play	Tape Guide Height Adjustment Nut	Adjust so that tape travels smoothly and does not twist.
2	Erase Head Height	Optional	Play	(k) (l)	Upper edge of Left Ch. head core is 0.1 mm higher than upper edge of tape.
3	Recording Head Height	Optional	Play	(a) (b) (c)	Upper edges of Left Ch. head core and tape are the same height. (Refer to NOTE 6.)
4	Playback Head Height	Optional	Play	(d) (e) (f)	Upper edges of Left Ch. head core and tape are the same height. (Refer to NOTE 6.)
5	Playback Head Azimuth Alignment	8,000 Hz 3-3/4 ips Test Tape	Play	(f)	Maximum output, both channels.
6	Playback Head Angle Alignment	8,000 Hz 3-3/4 ips Test Tape	Play	(i) (j)	Adjust head gap surface so that there is no change in output level when tension is applied to the supply reel side.
7	Recording Head Azimuth Alignment	Scotch #176 Tape 15,000 Hz -20 dBm	REC	(c)	Maximum output, both channels.
8	Recording Head Angle Alignment	Scotch #176 Tape 15,000 Hz -20 dBm	REC	(g) (h)	Adjust head gap surface so that there is no change in output level when tension is applied to the supply reel side.

Chart-3

- NOTES:**
1. As perfect head adjustments are vital to tape deck performance, be sure that these adjustments are carried out properly.
  2. Be careful not to use a magnetized driver or other magnetized tools in the vicinity of the heads.
  3. Use only new tape as level variation is likely to occur when using old tape.
  4. Demagnetize heads with head demagnetizer before and after head adjustment.
  5. Set tape speed to 7-1/2 ips.
  6. Simultaneously adjust the front and back tilts of head until uniform contact is ensured between the tape and the surface of head.



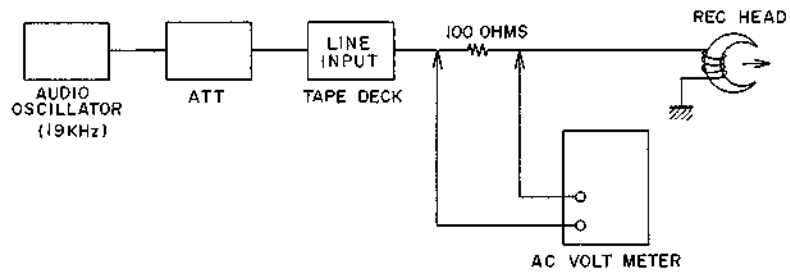

Fig. 24 Rec Peaking Adjustment Instrument Connection

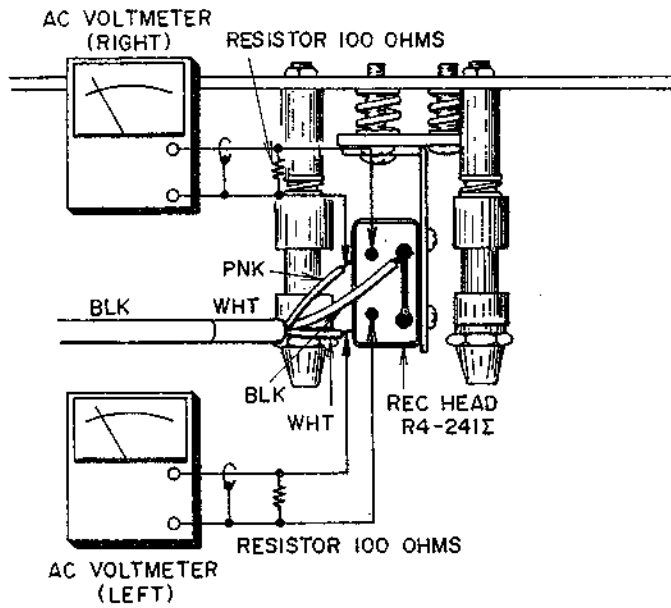

Fig. 25 Rec Peaking Adjustment

Step	Adjustment Item	Test Tape Supply Signal	Mode	Adjustment Point	Result	Remarks
1	Playback Level	700 Hz 7-1/2 ips OVU Test Tape	Play	VR 4 50 kB	0 ± 0.5 dBm (0.775V)	
2	VU Meter Sensitivity	700 Hz 7-1/2 ips OVU Test Tape	Play	5 kB	OVU indication	
3	REC Peaking	19 kHz from an oscillator	REC	VL 2 1.5 mH	Maximum AC Voltmeter indication	Tape Speed 3-3/4 ips. Refer to NOTE 4, 5, 7 and Figs. 18, 19, 20.
4	Recording Level	Scotch #176 Tape 1,000 Hz 0 dBm Recording	REC	VR 3 20 kB	0 ± 0.5 dBm (0.775V)	
5	Frequency Response (3-3/4 ips)	Scotch #176 Tape 1.5 kHz, 15 kHz -20dBm Recording	REC	TC 1 80 P	1.5 kHz 15 kHz flat	Tape Speed 3-3/4 ips. Recheck Recording Level.
6	Distortion Confirmation	Scotch #176 Tape 1,000 Hz 0 dBm Recording	REC		Less than 0.5%	See NOTE 6.
7	PB Amp Bias Filter	100 kHz from an oscillator	REC	VL 3 22 mH	Minimum AC Voltmeter indication	Set Monitor Switch to "TAPE". See NOTE 7, 8.
8	REC Amp Bias Filter	100 kHz from an oscillator	REC	VL 1 22 mH	Minimum AC Voltmeter indication	Set Monitor Switch to "SOURCE". See NOTE 7, 8.

Chart-4

- NOTES:**
1. Output Level Control should be at maximum.
  2. Except for Step 3 and 5, set Tape Speed to 7-1/2 ips.
  3. Set Tape Selector Switch to Low Noise position.
  4. Stop recording bias oscillator while making Rec Peaking Adjustment. (Refer to Fig. 23)
  5. When 19 kHz indicates the peak, check and ensure that the AC voltmeter shows 16 dB of increase when 15 kHz of input is fed rather than when 1 kHz is fed.
  6. If it does not comply with the specifications, repeat Steps 4 and 5, and re-adjust.
  7. Unless the core is moved intentionally this adjustment is not necessary.
  8. Adjust the oscillator's frequency to give a frequency counter reading of 100 kHz.

## X. DC RESISTANCE OF VARIOUS COILS

Part	Designation	DC Resistance
Main Motor	SCM-200	Between BLU-RED : 110 ohms Between YLW-BRN : 170 ohms Pick-up Coil : 665 ohms
Reel Motor	24XO-TD	Between BLU-RED : 30 ohms Between YLW-BRN : 157 ohms
Pinch Roller Plunger	1664PLTI	600 ohms $\pm 10\%$
Brake Plunger	1240 PLTI	600 ohms $\pm 10\%$
Pause Plunger	0730FLT	600 ohms $\pm 10\%$
Relay	MY4-02-US-L	650 ohms $\pm 15\%$
Relay	BR211	1,280 ohms $\pm 10\%$
Relay	LAB2NS	1,750 ohms $\pm 10\%$
Erase Head	E4-201	1.8 ohms
Recording Head	R4-241	5.9 ohms
Playback Head	P4-251	219 ohms $\pm 10\%$

Chart-5

# XI. CLASSIFICATION OF VARIOUS P.C BOARDS

---

## 1. P.C BOARD TITLES AND IDENTIFICATION NUMBERS

P.C Board Title	P.C Board Number
Power Supply & Sys. Con P.C Board	TG-5002A
Pre Amp P.C Board	TG-5001A
Fuse P.C Board	TG-5003
LED P.C Board	TG-5001B
Switch P.C Board	TG-5002B
Terminal P.C Board	NE-2230

Chart-6

2. COMPOSITION OF VARIOUS P.C BOARDS

1) POWER SUPPLY & SYS. CON P.C BOARD TG-5002A, SWITCH P.C BOARD TG-5002B & TERMINAL P.C BOARD NE-2230

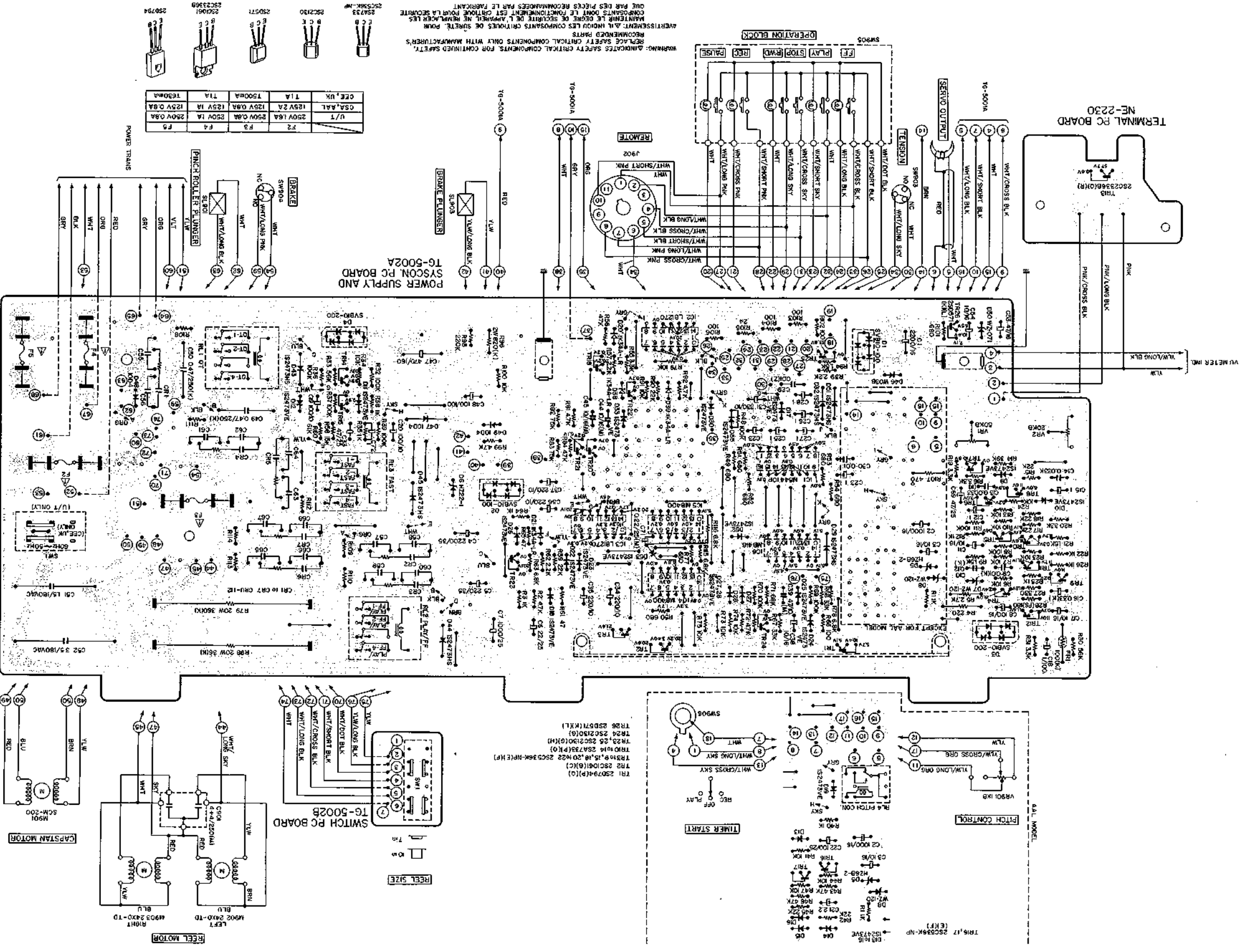





### 3) FUSE P.C BOARD TG-5003 (U/T)

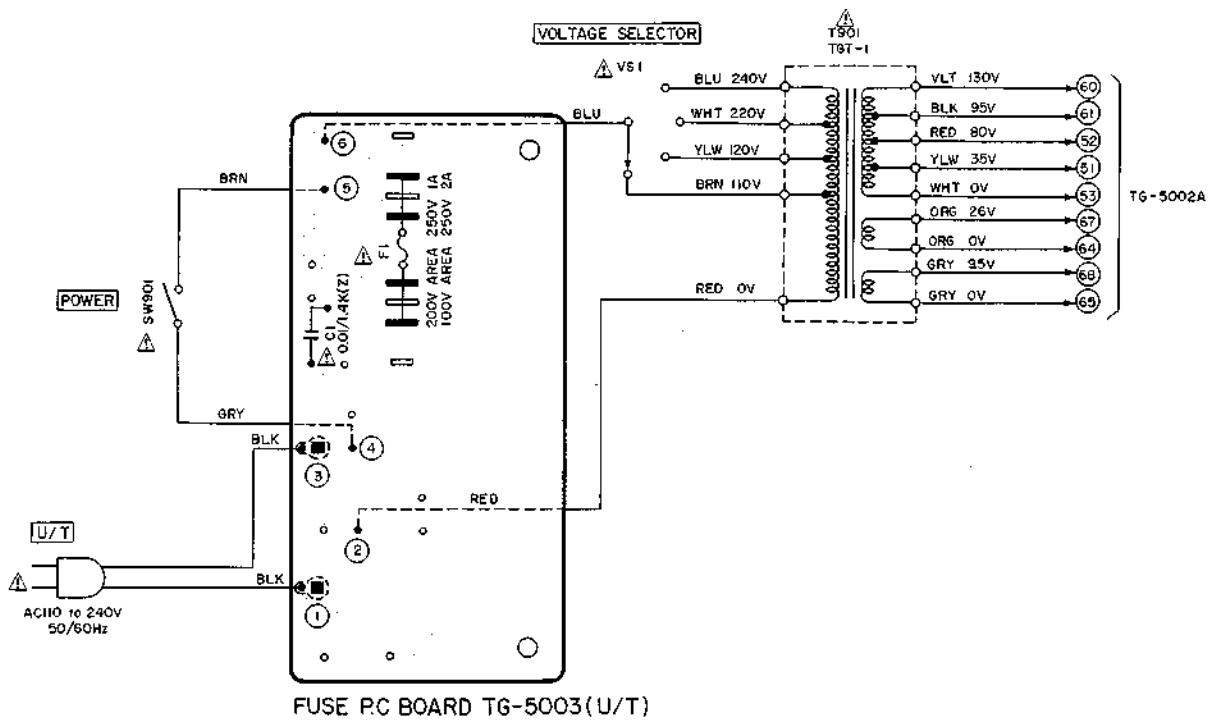

### 4) FUSE P.C BOARD TG-5003 (CSA, AAL)

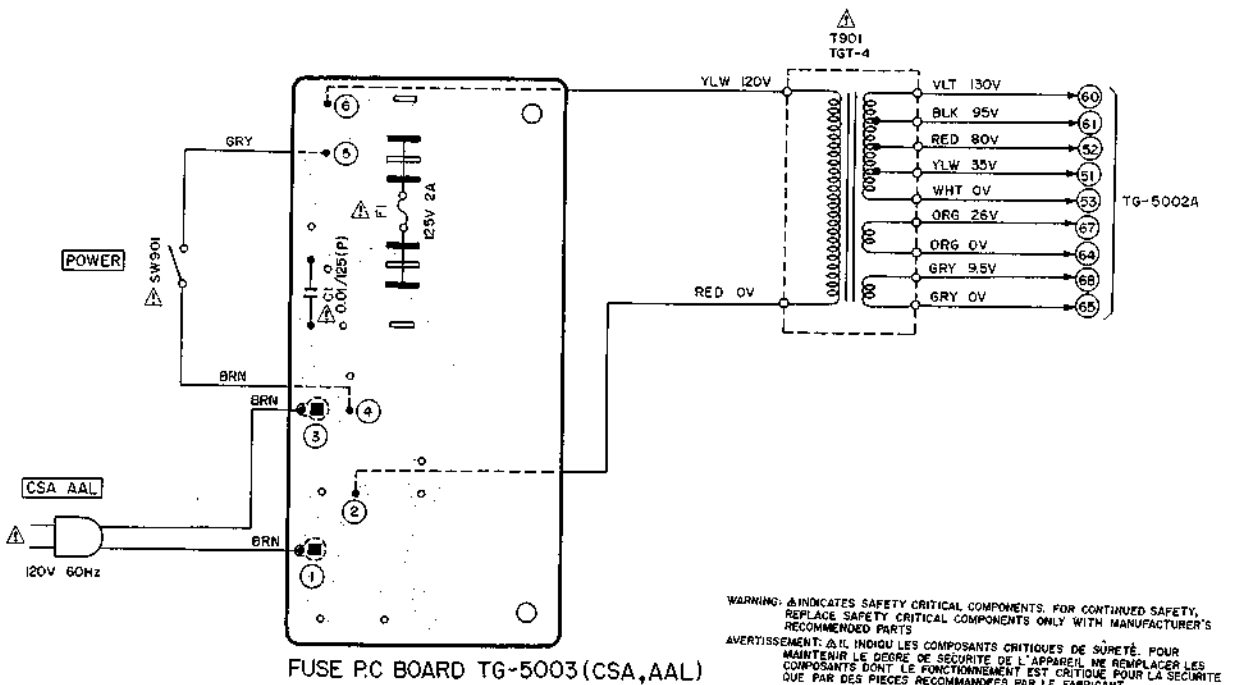

5) FUSE P.C BOARD TG-5003 (CEE, UK)

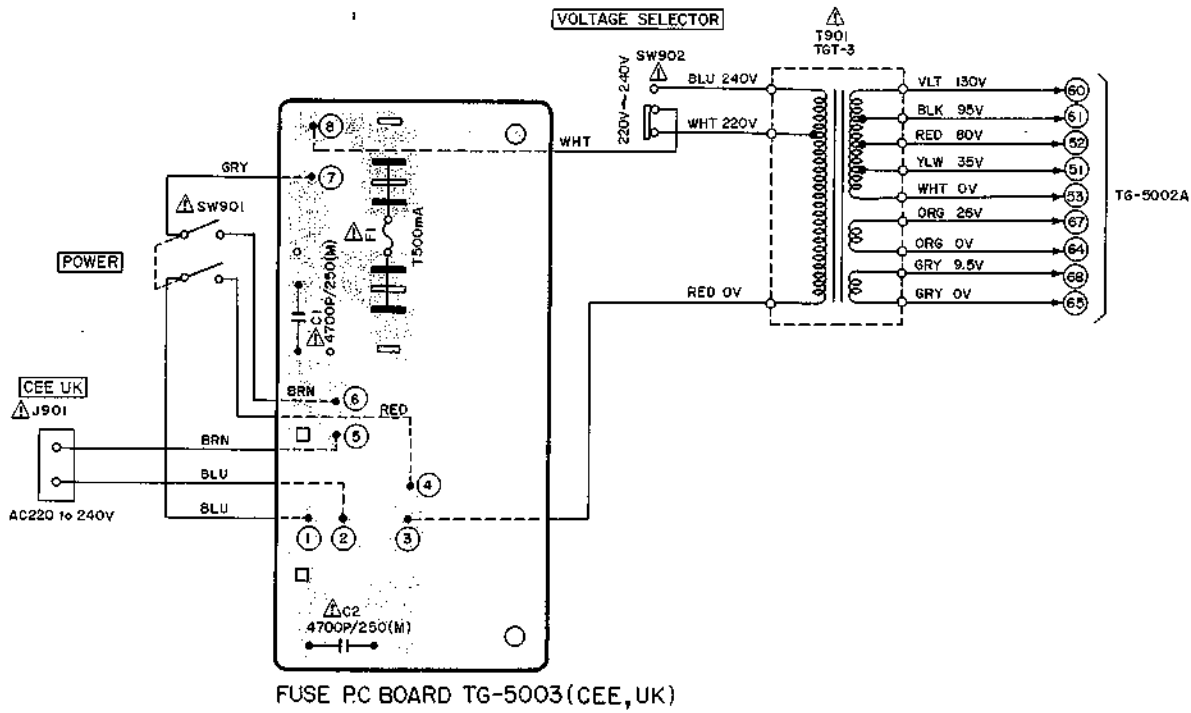

WARNING: ⚠ INDICATES SAFETY CRITICAL COMPONENTS. FOR CONTINUED SAFETY, REPLACE SAFETY CRITICAL COMPONENTS ONLY WITH MANUFACTURER'S RECOMMENDED PARTS

AVERTISSEMENT: ⚠ IL INDIQUE LES COMPOSANTS CRITIQUES DE SURETÉ. POUR MAINTENIR LE DEGRÉ DE SURETÉ DE L'APPAREIL, NE REMPLACER LES COMPOSANTS DONT LE FONCTIONNEMENT EST CRITIQUE POUR LA SURETÉ QUE PAR DES PIÈCES RECOMMANDÉES PAR LE FABRICANT



MEMO

---



MEMO

---

SECTION 2

**PARTS LIST**

TABLE OF CONTENTS

1. RECOMMENDED SPARE PARTS LIST . . . . .	40
2. HEAD BASE BLOCK . . . . .	42
3. MAIN MOTOR BLOCK . . . . .	43
4. REEL MOTOR/TABLE BLOCK . . . . .	44
5. IMPEDANCE ROLLER/TENSION ARM BLOCK . . . . .	45
6. POWER SUPPLY BLOCK . . . . .	46
7. AMP ASSEMBLY BLOCK . . . . .	47
8. MECHA ASSEMBLY BLOCK . . . . .	48
9. PRE AMP P.C BOARD (TG-5001A) BLOCK . . . . .	50
10. POWER & SYS. CON P.C BOARD (TG-5002A) . . . . .	50
11. FUSE P.C BOARD (TG-5003) . . . . .	51
12. FINAL ASSEMBLY BLOCK . . . . .	52
INDEX . . . . .	54

Resistor and Capacitor which is not listed in this parts list, please refer to COMMON LIST FOR SERVICE PARTS.

## HOW TO USE THIS PARTS LIST

1. This parts list is compiled by various individual blocks based on assembly process.
2. When ordering parts, please describe parts number, serial number, and model number in detail.
3. How to read List

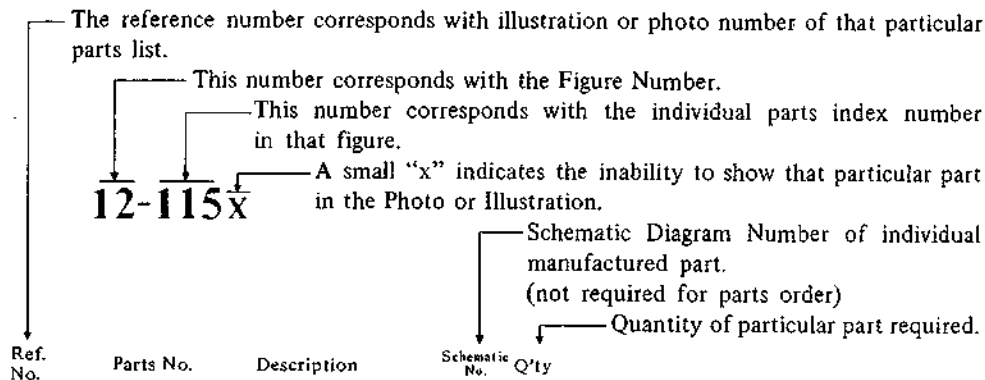

4. The symbol numbers shown on the P.C. Board list can be matched with the Composite Views of Components of the Schematic Diagram or Service Manual.
5. Please utilize separate "Common List for Service Parts" for Resistor Parts orders.
6. The shape of the parts and parts name, etc. can be confirmed by comparing them with the parts shown on the Electrical Parts Table of P.C. Board.
7. Both the kind of part and installation position can be determined by the Parts Number. To determine where a parts number is listed, utilize Parts Index at end of Parts List.  
It is necessary first of all to find the Parts Number. This can be accomplished by using the Reference Number listed at right of parts number in the Parts Index. (meaning of ref. no. outlined in Item 3 above).
8. Utilize separate "Price List for Parts" to determine unit price. The most simple method of finding parts Price is to utilize the reference number.

- CAUTION:**
1. When placing an order for parts, be sure to list the parts no., model no., and description. There are instances in which if any of this information is omitted, parts cannot be shipped or the wrong parts will be delivered.
  2. Please be careful not to make a mistake in the parts no. If the parts no. is in error, a part different from the one ordered may be delivered.
  3. Because parts number and parts unit supply in the Preliminary Service Manual (Basic Parts List) may be partially changed, please use this parts list for all future reference.

**WARNING:** **⚠** INDICATES SAFETY CRITICAL COMPONENTS. FOR CONTINUED SAFETY, REPLACE SAFETY CRITICAL COMPONENTS ONLY WITH MANUFACTURER'S RECOMMENDED PARTS.

**AVERTISSEMENT:** **⚠** IL INDIQU LES COMPOSANTS CRITIQUES DE SURETE. POUR MAINTENIR LE DEGRE DE SECURITE DE L'APPAREIL NE REMPLACER LES COMPOSANTS DONT LE FONCTIONNEMENT EST CRITIQUE POUR LA SECURITE QUE PAR DES PIECES RECOMMANDEES PAR LE FABRICANT.



## AC INLET SYSTEM

This model is equipped with an AC INLET SYSTEM. Please refer to the AC INLET SYSTEM CHART below for the specific type. By the AC INLET SYSTEM, AC (mains) cord can be connected to and disconnected from the model because the model is provided with socket exclusively for AC (mains) cord on its main body.

Please note, however, that certain models are not equipped with this system and has a built-in AC (mains) cord as before.

### AC INLET SYSTEM CHART

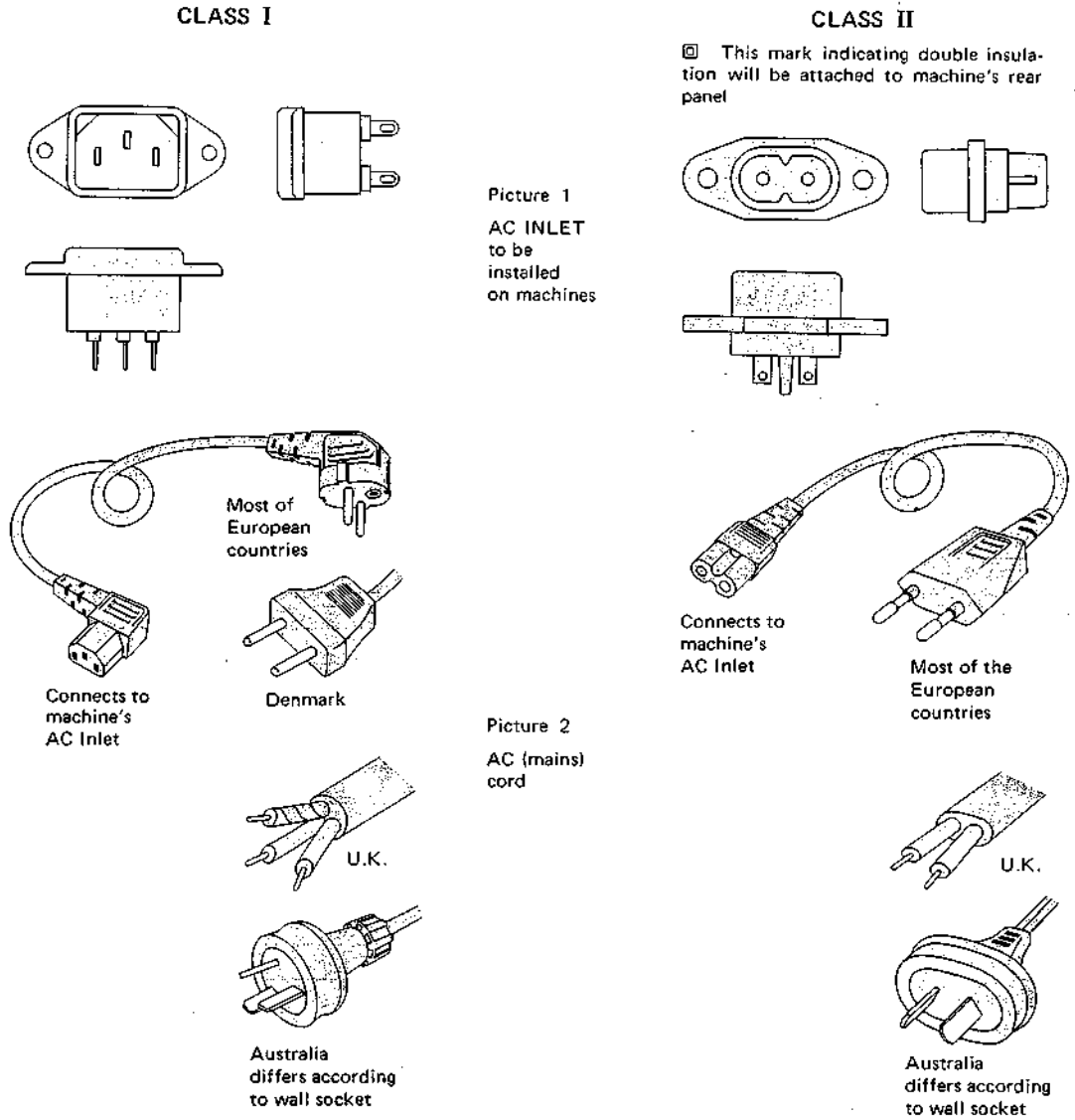

#### Parts List for AC (mains) Cord Set

	Standard	Description	Type of AC Inlet	Parts No.
Class I	CEE	Cord Set CEE (3 cores)	3P	EW302993
	BEAB	Cord Set BEAB (3 cores)	3P	EW302994
	SAA	Cord Set SAA (3 cores)	3P	EW302996
	U/T	Cord Set U/T (3 cores)	3P	EW302646
Class II	CEE	Cord Set CEE (2 cores)	2P	EW638144
	BEAB	Cord Set BEAB (2 cores)	2P	EW302995
	SAA	Cord Set SAA (2 cores)	2P	EW302991
	U/T	Cord Set U/T (2 cores)	2P	EW302899

## 1. RECOMMENDED SPARE PARTS LIST

Because, if the parts listed below are on hand, almost any repair can be accomplished, we suggest that you stock these Recommended Spare Parts Items.

Parts No.	Description	Notes
BA314235	Power & Sys. Con P.C Board Comp. GX-620 (U/T)	
BA314237	Power & Sys. Con P.C Board Comp. GX-620 (CSA)	
BA318811	Power & Sys. Con P.C Board Comp. GX-620-US	
BA314238	Power & Sys. Con P.C Board Comp. GX-620 (CEE)	CEE, UK, SAA
BA319390	Pre Amp P.C Board Comp. GX-620 (U/T)	
BA319392	Pre Amp P.C Board Comp. GX-620 (CEE)	
BH314075	Head Base Block Comp. GX-620	
BI314142	Impedance Roller Block Comp. GX-620	
BK314428	Operation Key Assy GX-620	
BL314141	Tension Arm Block Comp. GX-620	
BM308310	Motor Block Comp. (SCM-200) GX-635D	Main Motor
BM587518	Motor Block Comp. 24XO-FD TE	Reel Motor
BR587542	Reel Table Block Comp. TE (Supply)	
BR587553	Reel Table Block Comp. TE (Take-Up)	
BT316131	△ Power Trans. TGT-1	U/T
BT316133	△ Power Trans. TGT-3	CEE, UK, SAA
BT316134	△ Power Trans. TGT-4	CSA, US
ED310585	LED GL-9PG2	
ED308945	Silicon Diode SVB10-100	
ED306109	Silicon Diode W03B	
ED224550	Silicon Diode 10D4	
ED307236	Zener Diode HZ22-1	
ED309069	Zener Diode HZ6B-2	
ED281621	Zener Diode WZ-071	
ED510772	Zener Diode WZ-120	
EF308847	△ Fuse 1.6A 125V	CSA, US
EF311839	△ Fuse 1.6A 250V	U/T
EF310229	△ Fuse 1A 125V	CSA, US
EF309387	△ Fuse 1A 250V	U/T
EF309387	△ Fuse 1A 250V	U/T
EF306954	△ Fuse 2A 125V	CSA, US
EF306950	△ Fuse 2A 250V	U/T
EF309391	△ Fuse 800MA 125V	CSA, US
EF309388	△ Fuse 800MA 250V	U/T
EF623103	△ Fuse (Semko T Type) 1AT	CEE, UK, SAA
EF593706	△ Fuse (Semko T Type) 500MAT	CEE, UK, SAA
EF593706	△ Fuse (Semko T Type) 500MAT	CEE, UK, SAA
EF601942	△ Fuse (Semko T Type) 630MAT	CEE, UK, SAA
EI306141	IC LA4170	
EI316170	IC LB1270	
EI304165	IC MB400M	
EI304166	IC MB418	
EI308936	IC M54410P	
EJ301513	△ Inlet 2P	CEE, UK, SAA
EJ316156	Head Phone Jack HLJ0315-01-020	
EJ306289	Mic Jack HLJ0278-01-010	

Parts No.	Description	Notes
EJ306985	Pin Jack 4P	
EL316167	Lamp 24V 250MA	
EM316135	VU Meter KL-292B-1	
EM316689	VU Meter KL-292B-2	
EO383365	OSC. Coil OT-204	
EP315918	Plunger 1240PLTI	SL-903
EP308973	Relay LAB2NS DC24V	
EP300132	Relay MY4-02-US-L	
ES309059	△ Push SW. JP-27	U/T, CSA, US
ES310333	△ Push SW. (S) (D) JP-28	CEE, UK, SAA
ES306430	△ Slide SW. J-S4013#01	CEE, UK, SAA
ES315747	Lever SW. 42388	
ES562465	Micro SW. K-1	
ES316169	Push SW. SUF-12	
ES316158	Push SW. SUF-44	
ES316117	Rotary SW. SRN-1013N	Only US
ES309094	Slide SW. SL13-6-6-2-2-B	U/T
ET554657	Transistor 2SA733 (P) (Q)	
ET375603	Transistor 2SC1061 (B) (C)	
ET304181	Transistor 2SC2002 (K)	
ET308937	Transistor 2SC2130 (G) (H)	
ET308947	Transistor 2SC2336B (Q) (R)	
ET352146	Transistor 2SC458LG (D)	
ET316171	Transistor 2SC536K-NP (E) (F)	
ET639437	Transistor 2SC945L (Q) (P)	
ET666404	Transistor 2SD571 (K) (L)	
ET307349	Transistor 2SD794 (P) (Q)	
ET307349	Transistor 2SD794 (P) (Q)	
EV315751	Double-Axial 2-Throw/Vol. DM20R 50KAx2	
EV313538	Single-Axial 2-Throw/Vol. GM80R 10KBx2	
EV315928	Vol. VM10E 1KB	Only US
HE311139	Erase Head E4-201	
HP318522	PB Head P4-251	
HR308148	REC Head R4-241	
MB316029	Counter Belt	
MC316116	Counter MP490-35	
MC316685	Counter MP490-36	BL
MP582164	Pinch Roller D=42	
MT314987	Brake Band	

## 2. HEAD BASE BLOCK

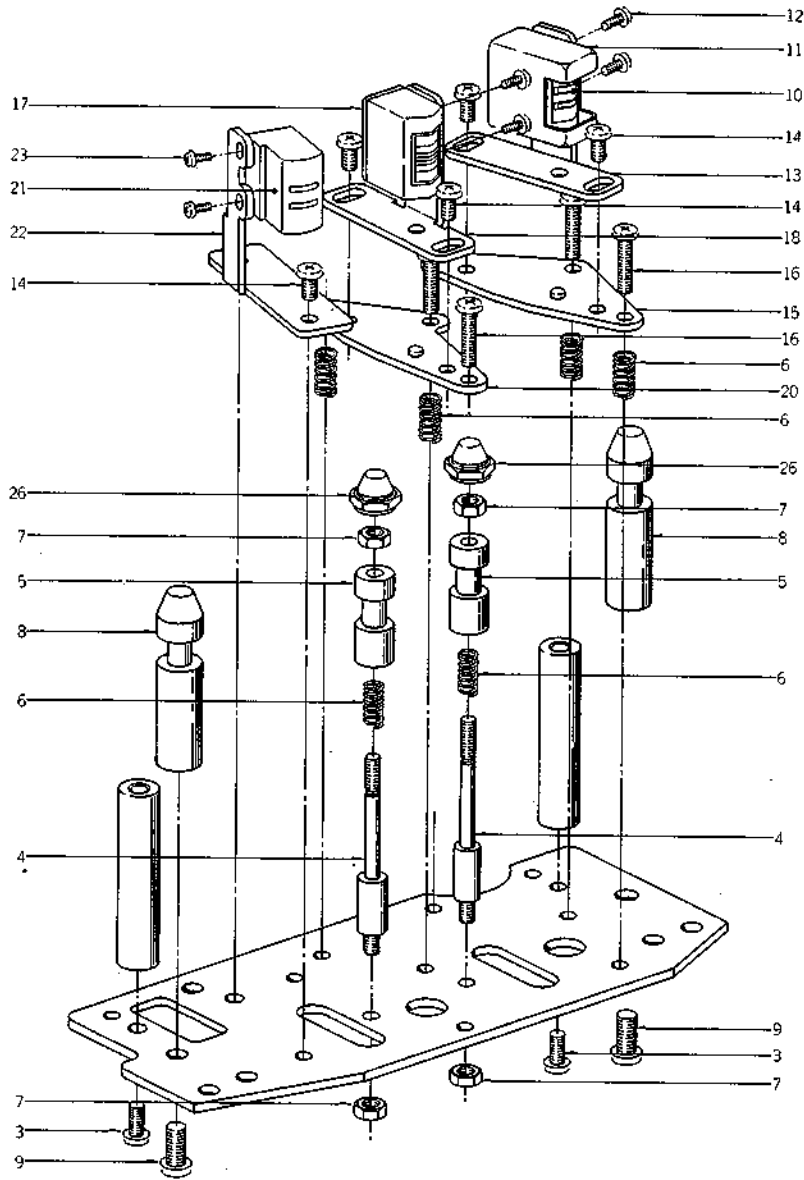

### HEAD BASE BLOCK

Ref. No.	Parts No.	Description	Schematic No.	Ref. No.	Parts No.	Description	Schematic No.
2-1x	BH314075	Head Base Block Comp. GX-620		2-15	HZ316006	P Head Base	TG-0005
2-2x	ZS417150	Screw, Pan 4x6		2-16	ZS608501	Screw, Pan 3x12 (Black)	
2-3	ZS379350	Screw, Pan 3x6		2-17	HR308148	REC Head R4-241	
2-4	MH316004	Tape Guide Prop	TG-0003	2-18	HA316009	RH Angle	TG-0008
2-5	HZ532710	Tape Guide (B)	TW-0006	2-19x	ZS539741	Screw, Pan 2x4 (Black)	
2-6	ZG466312	Angle Adjust Spring (E)	BS-0018	2-20	HZ316008	R Head Base	TG-0007
2-7	ZW265522	Nut, #2 M3		2-21	HE311139	Erase Head E4-201	
2-8	HZ316005	Tape Guide	TG-0004	2-22	HA321735	EH Angle	TG-0026
2-9	ZS413201	Screw, Pan 4x8		2-23	ZS304464	Screw, Pan 2x3 (Black)	
2-10	HP318522	PB Head P4-251		2-24x	EJ316129	4P Micro Connector Assy	26-6-332
2-11	HZ301366	Head Shield	NE-0211	2-25x	EJ316130	7P Micro Connector Assy	26-6-333
2-12	ZS608411	Screw, Pan Head 2x5					
2-13	HA316007	PH Angle	TG-0006				
2-14	ZS304806	Screw, Bind 3x5 (Black)		2-26	ZW316011	Decoration Nut	TG-0010

When ordering parts, please describe Parts Number, Description, and Model Number in detail.

### 3. MAIN MOTOR BLOCK

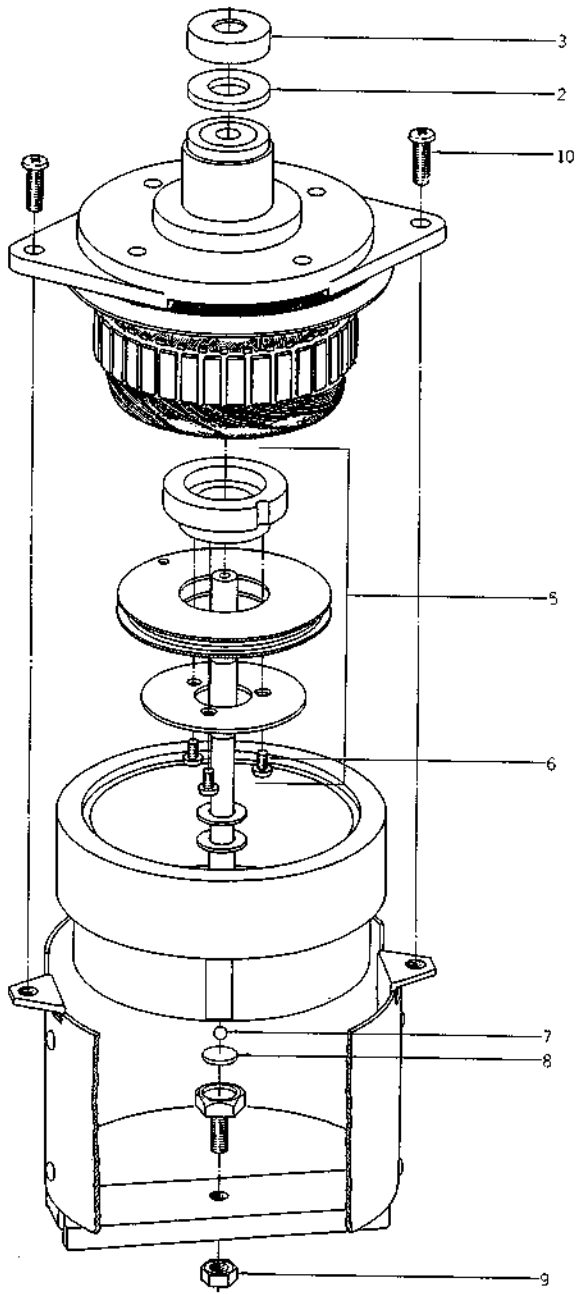

#### MAIN MOTOR BLOCK

Ref. No.	Parts No.	Description	Schematic No.
3-1x	BM308310	Motor Block Comp. (SCM-200) GX-635D	
3-2	ZW597622	Felt Washer	KJ-7022
3-3	SK597633	Cap	KJ-7023
3-4x	ZS608308	Screw, Pan 3x18 w/Washer	
3-5	BZ308315	Detection Gear Assy GX-635D	
3-6	ZS201508	Screw, Pan 2x4	
3-7	MV368886	Steel Ball D3	
3-8	MZ597690	Ball Holder,	KJ-7029
3-9	ZW413278	Nut, #1 M5	
3-10	ZS413201	Screw, Pan 4x8	

When ordering parts, please describe Parts Number, Description, and Model Number in detail.

#### 4. REEL MOTOR/TABLE BLOCK

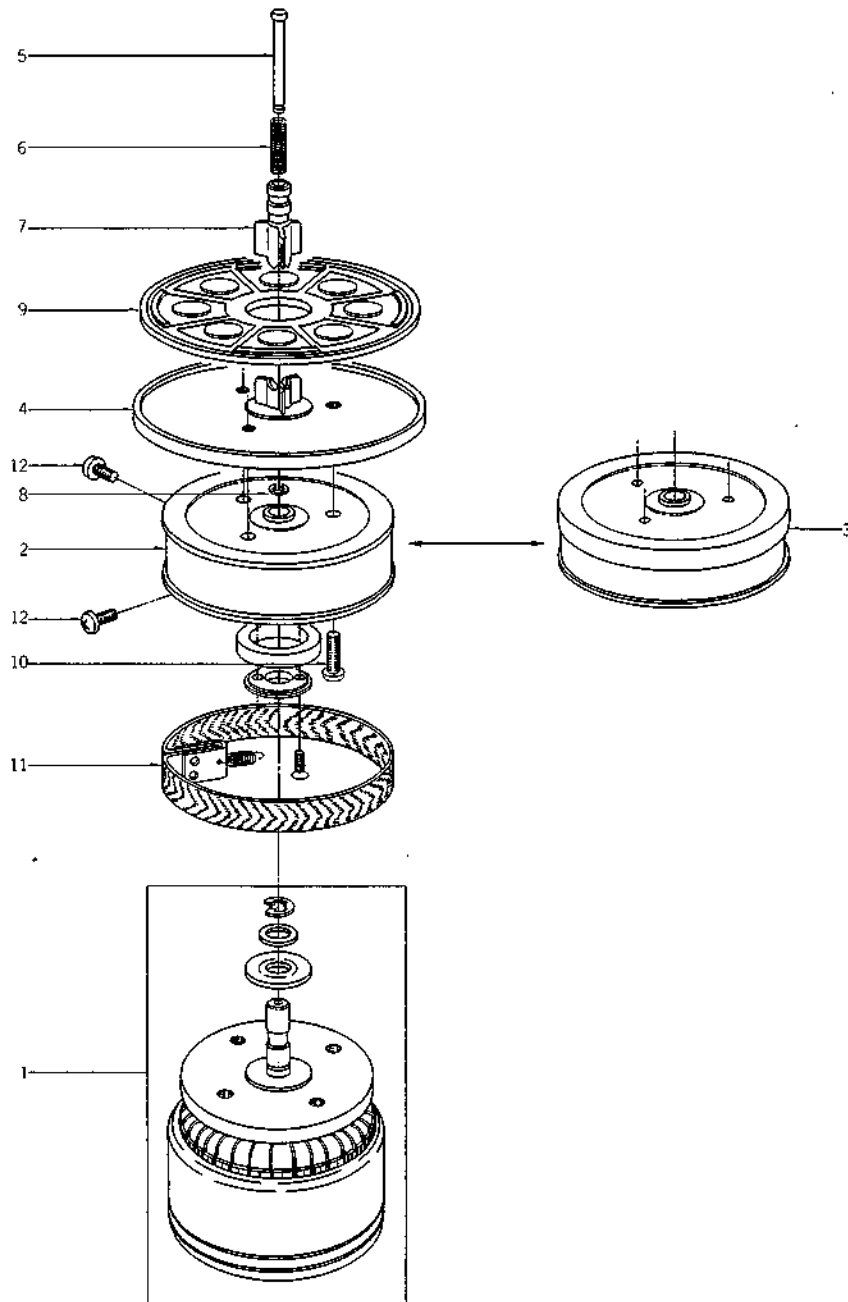

#### REEL MOTOR/TABLE BLOCK

Ref. No.	Parts No.	Description	Schematic No.	Ref. No.	Parts No.	Description	Schematic No.
<b>REEL MOTOR BLOCK</b>				4-5	MS342000	Reel Shaft	3R-108
4-1	BM587518	Motor Block Comp. 24XO-TD TE		4-6	ZG540617	Clamper Spring	TW-2096
<b>REEL TABLE BLOCK</b>				4-7	MT534677	Reel Clamper	TW-2032
4-2	BR587542	Reel Table Block Comp. TE (Supply)		4-8	ZW270088	'E' Ring 1.9M	6-1-9
4-3	BR587553	Reel Table Block Comp. TE (Take-up)		4-9	MT534688	Reel Table Rubber	TW-2033
4-4	MT534666	Reel Table	TW-2031	4-10	ZS419670	Screw, Pan 3x12	
				4-11	MT436860	Brake Cloth Comp.	MR-269
				4-12	ZS424056	Screw, Pan 4x10	

When ordering parts, please describe Parts Number, Description, and Model Number in detail.

## 5. IMPEDANCE ROLLER/TENSION ARM BLOCK

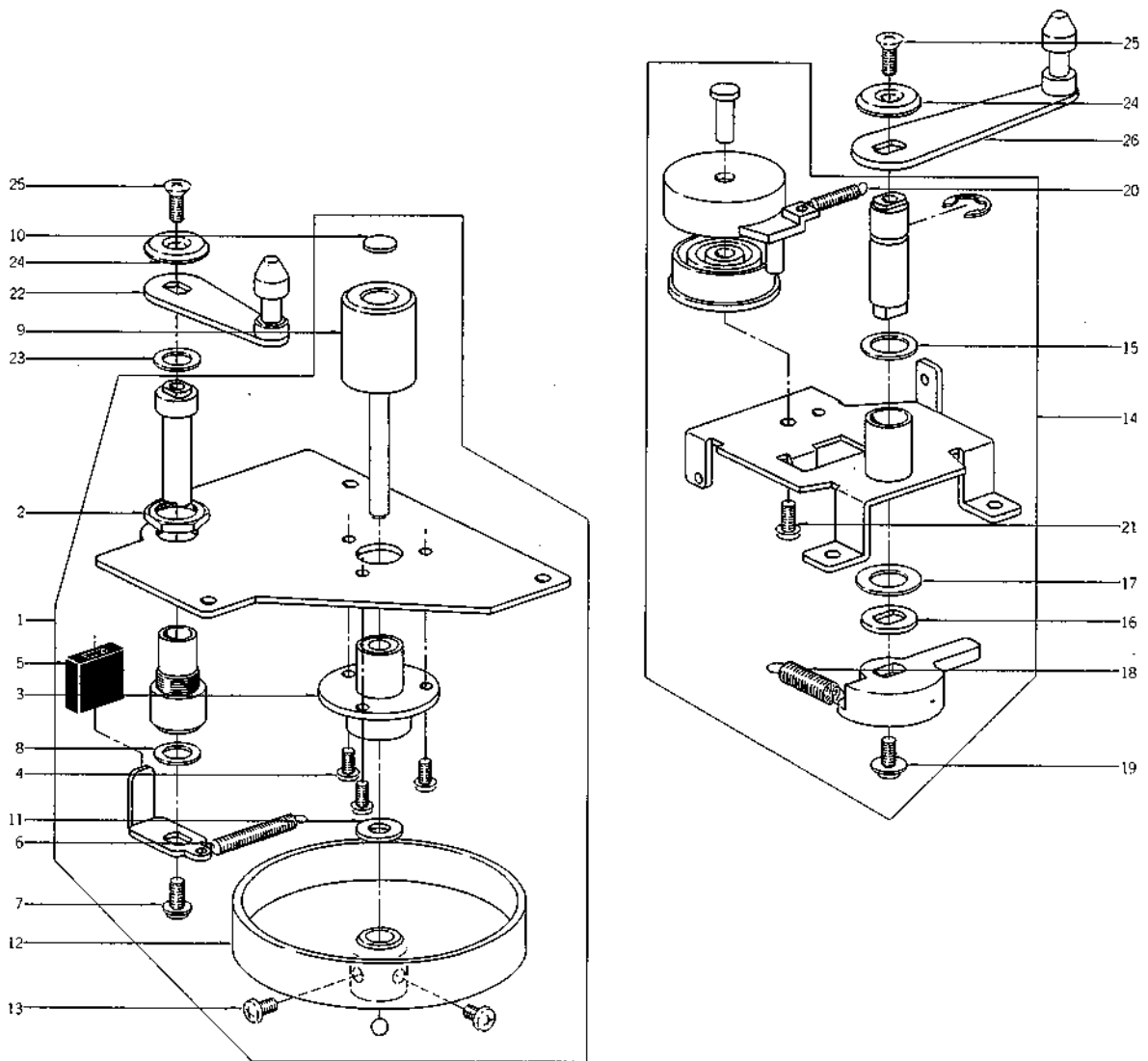

### IMPEDANCE ROLLER/TENSION ARM BLOCK

Ref. No.	Parts No.	Description	Schematic No.
<b>IMPEDANCE ROLLER BLOCK</b>			
5-1	BI314142	Impedance Roller Block Comp. GX-620	
5-2	ZW270191	E Jack Nut	
5-3	MZ674256	Metal Case Part	KJ-2031
5-4	ZS499331	Screw, Pan Head 2.3x5	
5-5	MB665561	TE Stopper Rubber	TE-2039
5-6	ZG232121	Tension Lever Spring	MH-143
5-7	ZS558101	Screw, Pan 3x6 w/Washer	
5-8	ZW260010	Washer (PBP) D6.1x10x0.1t	
5-9	BT673626	Impedance Roller Part	KJ-2034
5-11	ZW305533	Washer D4x10x1t	
5-12	MI691097	Flywheel Part TE	MY-2066
5-13	ZS422076	Screw, Pan 3x5	
<b>TENSION ARM BLOCK</b>			
5-14	BL314141	Tension Arm Block Comp. GX-620	

Ref. No.	Parts No.	Description	Schematic No.
5-15	ZW260256	Washer (PBP) D8.1x13x0.1t	
5-16	ZW580498	Tension Arm Washer	TD-2042
5-17	ZW575763	Washer (SPC) D8.1x13x0.5t	
5-18	ZG659608	Tension Spring	TE-2034
5-19	ZS608321	Screw, Pan 3x6 W=8	
5-20	ZG312947	Coil Spring T1-3.2/0.29-18.0	
5-21	ZS379350	Screw, Pan 3x6	
5-22	ML692504	Tension Arm Part TE	TE-2003
5-23	ZW560226	Washer (PBP) D6.1x10x0.2t	
5-24	ZW535094	Decorative Washer	TW-2077
5-25	ZS411660	Screw, Oval Countersunk Head 3x6	
5-26	ML694506	Tension Arm Part TD	TD-2039

When ordering parts, please describe Parts Number, Description, and Model Number in detail.

## 6. POWER SUPPLY BLOCK

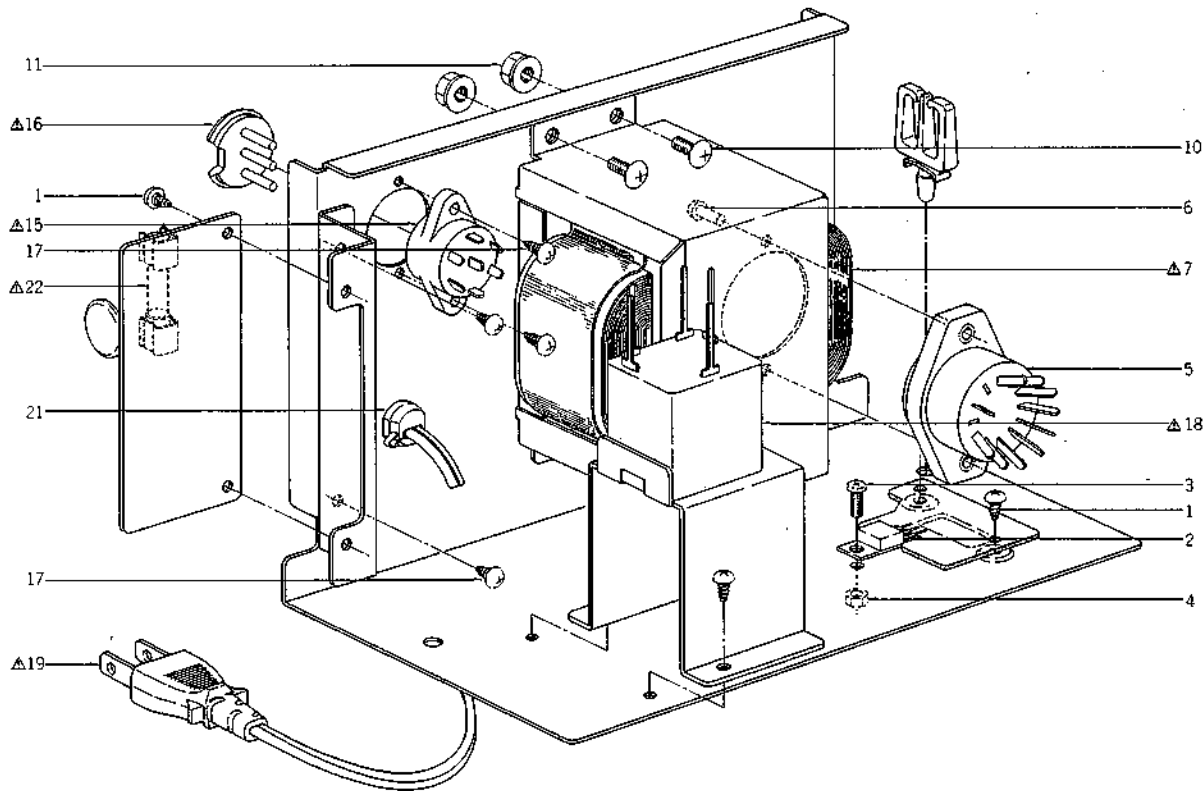

### POWER SUPPLY BLOCK

Ref. No.	Parts No.	Description	Schematic No.	Ref. No.	Parts No.	Description	Schematic No.
6-1	ZS325495	Tapping Screw, #2 BR 3x6		6-14x	ZS447761	Tapping Screw, #2 BR 3x6 (Black) (CEE, UK, SAA)	
6-2	ET308947	Transistor 2SC2336B(Q)(R)	45-1-333	6-15	EJ262732	Δ Socket (Volt. Selector) (U/T)	31-1-190
6-3	ZS421806	Screw, Pan 3x8		6-16	EJ249467	Δ Voltage Selector (U/T)	42-1-109
6-4	ZW273756	Nut, #1 M3		6-17	ZS447840	Tapping Screw, #2 BR 3x8	
6-5	EJ307274	9P Remo. Con Socket	31-1-223	6-18	EC316065	Δ Metallized Polyester/C. 4+4μF (M) 250VAC	24-16-18
6-6	ZS421740	Screw, Pan 3x8 (Black)		6-19	EW306428	Δ AC Cord (U/T)	26-3-64
6-7	BT316131	Δ Power Trans. TGT-1 (U/T)	38-4-716	6-20x	EW305691	Δ AC Cord CUL (CSA, US)	26-3-65
6-8x	BT316134	Δ Power Trans. TGT-4 (CSA, US)	38-4-719	6-21	EZ631945	Strain Relief SR-4N-4 (U/T, CSA)	2-7-49
6-9x	BT316133	Δ Power Trans. TGT-3 (CEE, UK, SAA)	38-4-718	6-22	EF309387	Δ Fuse 1A 250V (U/T)	39-1-64
6-10	ZS435273	Screw, Binding Head 4x10		6-23x	EF306950	Δ Fuse 2A 250V (U/T)	39-1-64
6-11	ZW413267	Flange Nut M4		6-24x	EF306954	Δ Fuse 2A 125V (CSA, US)	39-1-65
6-12x	EJ301513	Δ Inlet 2P (CEE, UK, SAA)	31-1-200	6-25x	EF593706	Δ Fuse (Semko T Type) 500MAT (CEE, UK, SAA)	39-1-63
6-13x	ES306430	Δ Slide SW. J-S4013#01 (CEE, UK, SAA)	25-3-142				

When ordering parts, please describe Parts Number, Description, and Model Number in detail.



## 7. AMP ASSEMBLY BLOCK

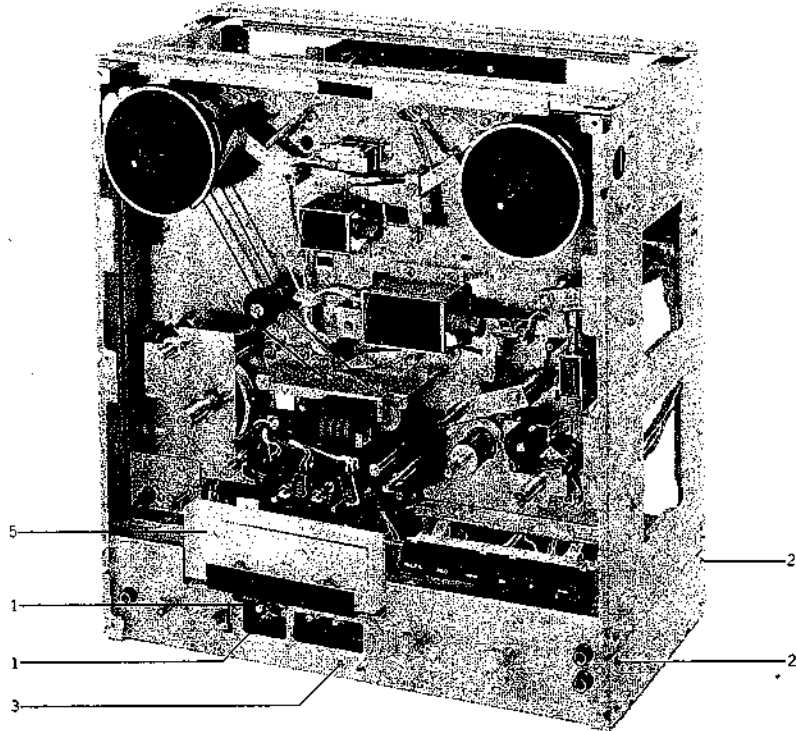

### AMP ASSEMBLY BLOCK

Ref. No.	Parts No.	Description	Schematic No.
<b>LED P.C BOARD BLOCK</b>			
7-1	ED310585	LED GL-9PG2	45-15-22
<b>AMP ASSEMBLY BLOCK</b>			
7-2	ZS325495	Tapping Screw, #2 BR 3x6	
7-3	ZS422076	Screw, Pan 3x5	
7-4x	ZW263946	Nylon Rivet 4x5	2-7-57
7-5	EM316135	VU Meter KL-292B-1	46-1-229
7-6x	EM316689	VU Meter KL-292B-2 (BL)	46-1-232
7-7x	ZS447761	Tapping Screw, #2 BR 3x6 (Black)	

8. MECHA ASSEMBLY BLOCK

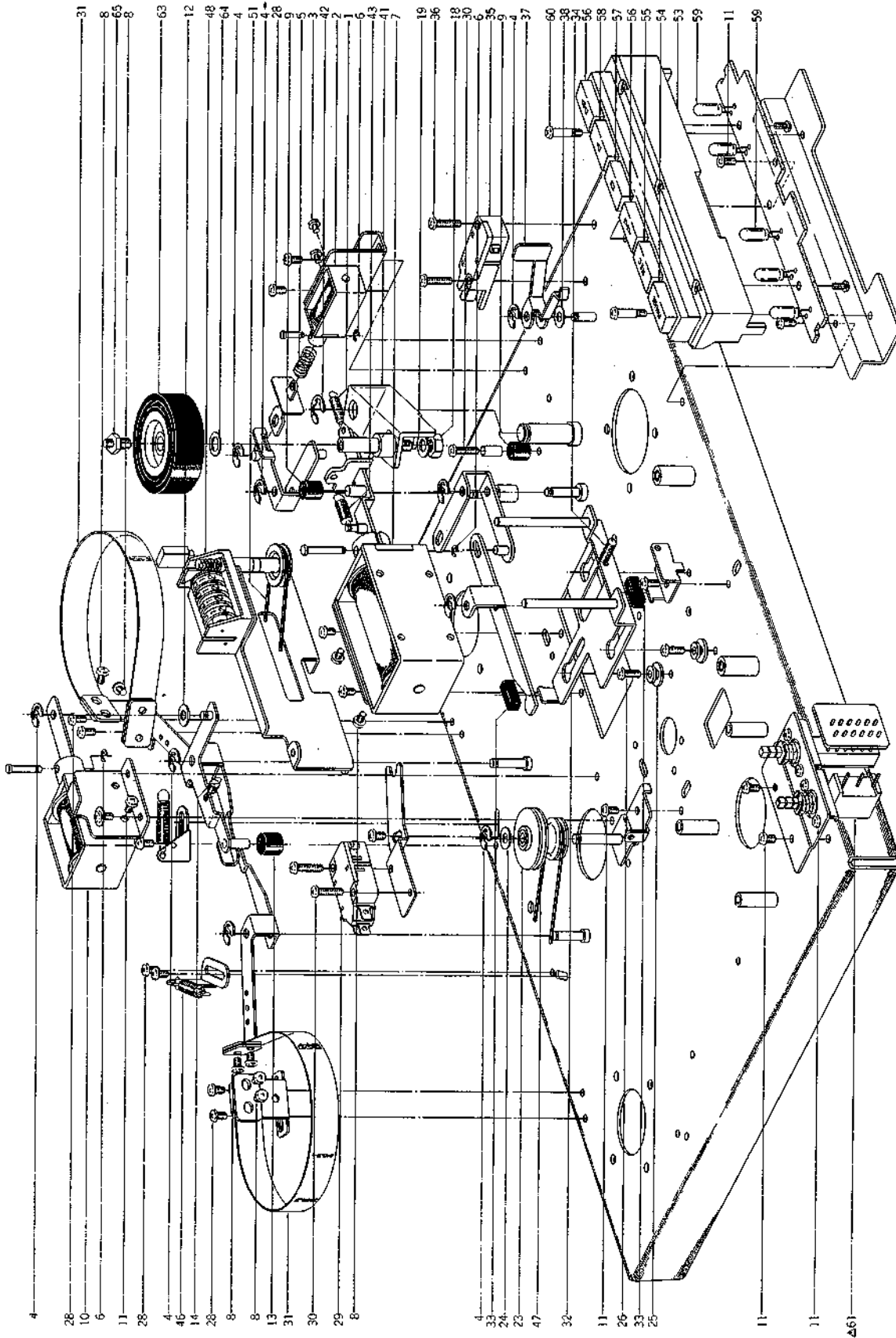

## MECHA ASSEMBLY BLOCK

Ref. No.	Parts No.	Description	Schematic No.	Ref. No.	Parts No.	Description	Schematic No.
<b>PAUSE PLUNGER BLOCK</b>							
8-1	ZG321132	P Lever Spring	TG-2024	8-63	MP582164	Pinch Roller D=42	TD-1034
8-2	EP309056	Plunger 0730FLT	44-1-105	8-64	ZW376391	Washer (Polyslider) D6.1x10x0.13t	
8-3	ZS592378	Screw, Pan 2.6x3		8-65	ZS527681	Pinch Roller Set Screw	ND-6019
8-4	ZW290283	'U' Ring 2.85M	6-1-1				
8-5	ZG308743	Joint Spring	TH-2031				
8-6	ZW270088	'E' Ring 1.9M	6-1-9				
<b>PINCH ROLLER PLUNGER BLOCK</b>							
8-7	EP316121	Plunger	44-1-119				
8-8	ZS417216	Screw, Pan 3x4					
8-9	MB606712	Stopper Rubber KJ	KJ-2060				
<b>BRAKE PLUNGER BLOCK</b>							
8-10	EP315918	Plunger 1240PLTI	44-1-120				
8-11	ZS422076	Screw, Pan 3x5					
8-12	ZW420682	Washer (Nylon) D4.2x9x0.5t					
8-13	MZ397181	Lever Cushion	KD-1069				
8-14	ZG580522	Clutch Lever Spring	TD-2045				
<b>MECHA ASSEMBLY BLOCK</b>							
8-15	ZS413201	Screw, Pan 4x8					
8-16x	ZW273756	Nut, #1 M3					
8-17x	ZW413188	Nut, #1 M4					
8-18	ZW413278	Nut, #1 M5					
8-19	ZW274026	Spring Washer, M5					
8-20x	ZW462205	Washer (Nylon) D7.9x1t (Without Hole)					
8-21x	ZS380046	Screw, Pan Head 3x10					
8-22x	ZS325495	Tapping Screw, #2 BR 3x6					
8-23	MR691942	Middle Pulley Part TE-1	TD-1048				
8-24	ZW676045	Washer (Teflon) D4.2x9x0.5t					
8-25	MH316022	Collar	TG-1009				
8-26	ZS421806	Screw, Pan 3x8					
8-27x	ZS417150	Screw, Pan 4x6					
8-28	ZS323728	Screw, Binding Head 3x5					
8-29	ES573478	Micro SW. K-3	25-1-31				
8-30	ZS419670	Screw, Pan 3x12					
8-31	MT314987	Brake Band	MR-213				
8-32	ML314426	Shifter Plate Part GX-620	TG-1010				
8-33	MB668801	Stopper Rubber (B) TE	TE-2039				
8-34	ZG312998	Coil Spring					
8-35	ES562465	Micro SW. K-1	25-1-26				
8-36	ZS483502	Screw, Pan Head 3x13					
8-37	MZ580680	Actuator	TD-2068				
8-38	ZW316136	Washer D4.1x9x0.5t Nylon					
8-39x	ZS432674	Screw, Pan Head 3x3					
8-40x	MV249074	Steel Ball D4					
8-41	BL314071	P Arm Assy GX-620	TG-2028				
8-42	ZW270156	'E' Ring 6M	6-1-9				
8-43	ZG316040	P Spring	TG-2008				
8-44x	EV315928	Vol. VM10E 1KB (US)	36-6-38				
8-45x	ES316117	Rotary SW. SRN-1013N (US)	25-6-172				
8-46	ZG672478	Brake Spring	TE-1017				
8-47	MBS27556	Counter Belt D93x1.5	ND-1022				
8-48	MC316116	Counter MP490-35	9-1-72				
8-49x	MC316685	Counter MP490-36 (BL)	9-1-80				
8-50x	ZS417137	Screw, Binding Head 3x4					
8-51	MB316029	Counter Belt	TG-1016				
8-52x	ZS413245	Screw, Pan Head 4x15					
8-53	BK314428	Operation Key Assy GX-620	25-5-324				
8-54	SB316162	Operation Button (Pause)	25-5-324				
8-55	SB316163	Operation Button (REC)	25-5-324				
8-56	SB316164	Operation Button (FF, REW)	25-5-324				
8-57	SB316165	Operation Button (Stop)	25-5-324				
8-58	SB316166	Operation Button (FWD)	25-5-324				
8-59	EL316167	Lamp 24V 250MA	25-5-324				
8-60	ZS316119	Graduated Screw	TG-1020				
8-61	ES309059	△ Push SW. JP-27 (U/T, CSA, US)	25-5-285				
8-62x	ES310333	△ Push SW. (S) (D) JP-28 (CEE, UK, SAA)	25-5-308				

When ordering parts, please describe Parts Number, Description, and Model Number in detail.

### 9. PRE AMP P.C BOARD (TG-5001A) BLOCK

Symbol No.	Parts No.	Description	Schematic No.
9-1	BA319390	Pre Amp P.C Board Comp. GX-620 (U/T) (U/T, CSA, US)	TG-5001A
9-2	BA319392	Pre Amp P.C Board Comp. GX-620 (CEE) (CEE, UK, SAA)	TG-5001A
9-IC1	EI306141	IC LA4170	45-8-305
9-TR1to3	ET352146	Transistor 2SC458LG(D)	45-1-29
9-TR4,5	ET639437	Transistor 2SC945L(Q)(P)	45-1-85
9-TR6,7	ET304181	Transistor 2SC2002(K)	45-1-281
9-TR8to10	ET352146	Transistor 2SC458LG(D)	45-1-29
9-TR11,12	ET639437	Transistor 2SC945L(Q)(P)	45-1-85
9-TR13	ET313717	FET 2SK68A(M)	45-12-9
9-TR14	ET639437	Transistor 2SC945L(Q)(P)	45-1-85
9-TR15	ET307349	Transistor 2SD794(P)(Q)	45-1-334
9-TR16to20	ET639437	Transistor 2SC945L(Q)(P)	45-1-85
9-D1	ED318292	Silicon Diode 1S2473T-77	45-3-59
9-D2	ED308953	Germanium Diode 1K34A-LH	45-3-46
9-D3	ED318292	Silicon Diode 1S2473T-77	45-3-59
9-D4,5	ED308953	Germanium Diode 1K34A-LH	45-3-46
9-D6,7	ED560913	Silicon Diode 1S2473 VE	45-3-23
9-D8to10	ED318292	Silicon Diode 1S2473T-77	45-3-59
9-D11	ED560913	Silicon Diode 1S2473 VE	45-3-23
9-FR1	ER308898	Fuse/R. 1/4W 100ohms(J)	35-14-23
9-VC1	EC558202	Trimmer/C. TM-80A 80PF	24-2-26
9-VR1,2	EV315751	Double-Axial 2-Throw/Vol. DM20R 50KAx2	36-18-16
9-VR3	EV315753	Semi-Fixed/Vol. D8 Axial 20KB	36-10-282
9-VR4	EV315541	Semi-Fixed/Vol. D8 Axial 50KB	36-10-282
9-VR5	EV313538	Single-Axial 2-Throw/Vol. GM80R 10KBx2	36-22-43
9-VR6	EV315540	Semi-Fixed/Vol. D8 Axial 5KB	36-10-282
9-J1	EJ306289	MIC Jack HLJ0278-01-010	31-2-91
9-J2	EJ316156	Head Phone Jack HLJ0315-01-020	31-2-106
9-J3	EJ306985	Pin Jack 4P	31-5-142
9-SW1to4	ES316158	Push SW. SUF-44	25-5-322
9-SW6	ES315747	Lever SW. 42388	25-12-61
9-P1	EJ249333	Micro Connector 4P Plug W-P0504	42-1-104
9-P2	EJ249366	Micro Connector 7P Plug W-P0507	42-1-104
9-RL1	EP308973	Relay LAB2NS DC24V	47-2-30
9-T1	ED383365	OSC. Coil OT-204	23-4-20
9-L1	EO301467	Ferri Inductor RX-9P 3.3MH(J)	23-1-275
9-L2	EO316142	Ferri Inductor RC875 220uH(J)	23-1-335
9-VL1	EO346230	Inductor RX 22MH	23-1-15
9-VL2	EO316141	Inductor 55T131 1.5MH	23-1-315
9-VL3	EO346230	Inductor RX 22MH	23-1-15
9-C14	EC306438	Styrol/C. (Homing Type) 100PF(J) 50WV	24-11-14
9-C28	EC306420	Styrol/C. (Homing Type) 750PF(J) 50WV	24-11-14
9-C29	EC316149	Styrol/C. 1800PF(J) 500WV	24-11-16
9-C44	EC316150	Styrol/C. 820PF(J) 50WV	24-11-14
9-C70	EC321173	Styrol/C. 180PF(J) 50WV	24-11-14

### 10. POWER & SYS. CON P.C BOARD (TG-5002A) BLOCK

Symbol No.	Parts No.	Description	Schematic No.
10-1	BA314235	Power & Sys. Con P.C Board Comp. GX-620 (U/T)	TG-5002A
10-2	BA314237	Power & Sys. Con P.C Board Comp. GX-620 (CSA)	TG-5002A
10-3	BA318811	Power & Sys. Con P.C Board Comp. GX-620-US	TG-5002A
10-4	BA314238	Power & Sys. Con P.C Board Comp. GX-620 (CEE) (CEE, UK, SAA)	
10-IC1	EI308936	IC M54410P	45-8-304
10-IC2,3	EI316170	IC .LB1270	45-8-369
10-IC4,5	EI304165	IC MB400M	45-8-252
10-IC6	EI304166	IC MB418	45-8-253
10-TR1	ET307349	Transistor 2SD794(P)(Q)	45-1-334
10-TR2	ET375603	Transistor 2SC1061(B)(C)	45-1-96
10-TR3to9	ET316171	Transistor 2SC536K-NP(E)(F)	45-1-362
10-TR10to14	ET554657	Transistor 2SA733(P)(Q)	45-1-124
10-TR15to22	ET316171	Transistor 2SC536K-NP(E)(F)	45-1-362
10-TR23	ET308937	Transistor 2SC2130(G)(H)	45-1-317
10-TR24	ET310832	Transistor 2SC2130(G)	45-1-317
10-TR25	ET308937	Transistor 2SC2130(G)(H)	45-1-317
10-TR26	ET666404	Transistor 2SD571(K)(L)	45-1-218
10-D1,2	ED308945	Silicon Diode SVB10-100	45-2-82
10-D3,4	ED308941	Silicon Diode SVB10-200	45-2-82
10-D5	ED309069	Zener Diode HZ6B-2	45-6-80
10-D6	ED307236	Zener Diode HZ22-1	45-6-80
10-D7,8	ED510772	Zener Diode WZ-120	45-6-67
10-D9to19	ED560913	Silicon Diode 1S2473 VE	45-3-23
10-D20,21	ED308952	Germanium Diode 1K34A-LR	45-3-47
10-D22to28	ED560913	Silicon Diode 1S2473 VE	45-3-23
10-D29	ED316143	Silicon Diode 1S2473HS	45-3-53
10-D30	ED560913	Silicon Diode 1S2473 VE	45-3-23
10-D31	ED308952	Germanium Diode 1K34A-LR	45-3-47
10-D32	ED316143	Silicon Diode 1S2473HS	45-3-53
10-D33	ED560913	Silicon Diode 1S2473 VE	45-3-23
10-D34to41	ED308952	Germanium Diode 1K34A-LR	45-3-47
10-D42	ED560913	Silicon Diode 1S2473 VE	45-3-23
10-D43to45	ED316143	Silicon Diode 1S2473HS	45-3-53
10-D46	ED306109	Silicon Diode W03B	45-2-78
10-D47to49	ED224550	Silicon Diode 10D4	45-2-16
10-D50	ED281621	Zener Diode WZ-071	45-6-67
10-D51	ED316143	Silicon Diode 1S2473HS	45-3-53
10-D52to55	ED560913	Silicon Diode 1S2473 VE	45-3-23
10-SW1	ES316169	Push SW. SUF-12	25-5-321
10-SW1	ES309094	Slide SW. SL13-6-6-2-2-B	25-3-159
10-VR1	EV302718	Semi-Fixed/Vol. V18K3-6(4US) 50KB	36-9-26
10-VR2	EV309071	Semi-Fixed/Vol. V18K3-6(4US) 20KB	36-9-26
10-RL1to3	EP300132	Relay MY4-02-US-L	47-1-32
10-RL4	EP308949	Relay BR211	47-2-31
10-CR1to7	ER300820	Spark Quencher CRU-112 0.1u+120 ohms 125WV	41-1-63
10-R4	ER666854	Carbon/R. F 1/2W 220 ohms (J)	35-11-13
10-R27	ER663298	Carbon/R. (Insu. Type) F 1/4W 330 ohms (J)	35-11-12
10-R28	ER233638	Carbon/R. F 1/4W 180 ohms (J)	35-11-12
10-R29	ER309092	Metal Oxide Film/R. 2W 820 ohms (K)	35-15-8
10-R97	ER318415	Cement/R. 20W 360 ohms (K)	35-16-81
10-R98	ER308955	Cement/R. (Home. Type) 20W 36 ohms (K)	35-16-81
10-CI	EC316182	Elect./C. (Vert.) 2200uF 16WV	24-12-46

When ordering parts, please describe Parts Number, Description, and Model Number in detail.

Symbol No.	Parts No.	Description	Schematic No.
10-C4	EC316230	Elect./C. (Vert.) 2200 $\mu$ F 35WV	24-12-46
10-C7	EC316184	Elect./C. (Vert.) 1000 $\mu$ F 25WV	24-12-46
10-C44,45	EC313534	NP/C.	24-17-31
10-C47	EC316195	Elect./C. 470 $\mu$ F 160WV	24-12-53
10-C49,50	EC316194	Metallized Polyester/C. 0.4 $\mu$ F 250WV	24-16-22
10-C51	EC316192	Metallized Polyester/C. 1.5 $\mu$ F (K) 180WV	24-16-20
10-C52	EC316193	Metallized Polyester/C. 3.5 $\mu$ F (K) 180WV	24-16-21
10-C55to68	EC316191	Metallized Polyester/C. 0.1 $\mu$ F 250WV	24-16-19
10-C71	EC321146	Solid Aluminum/C. 0.22 $\mu$ F (M) 25WV	24-19-3
10-5	ZS421806	Screw, Pan 3x8	
10-6	ZW273756	Nut, #1 M3	
10-F2	EF311839	Fuse 1.6A 250V (U/T)	39-1-64
10-F2	EF308847	Fuse 1.6A 125V (CSA, US)	39-1-65
10-F2	EF623103	Fuse (Semko T Type) 1AT (CEE, UK, SAA)	39-1-53
10-F3	EF309388	Fuse 800MA 250V. (U/T)	39-1-64
10-F3	EF309391	Fuse 800MA 125V (CSA, US)	39-1-65
10-F3	EF593706	Fuse (Semko T Type) 500MAT (CEE, UK, SAA)	39-1-53
10-F4	EF309387	Fuse 1A 250V (U/T)	39-1-64
10-F4	EF310229	Fuse 1A 125V (CSA, US)	39-1-65
10-F4	EF623103	Fuse (Semko T Type) 1AT (CEE, UK, SAA)	39-1-53
10-F5	EF309388	Fuse 800MA 250V (U/T)	39-1-64
10-F5	EF309391	Fuse 800MA 125V (CSA, US)	39-1-65
10-F5	EF601942	Fuse (Semko T Type) 630MAT (CEE, UK, SAA)	39-1-53

## 11. FUSE P.C BOARD (TG-5003) BLOCK

Symbol No.	Parts No.	Description	Schematic No.
11-C1	EC551160	$\Delta$ Ceramic/C. DB821 NA 0.01 $\mu$ F (Z) 1.4KWV (U/T)	24-5-55
11-C1	EC314688	$\Delta$ Ceramic/C. DE7150 FZ 0.01 $\mu$ F (P) 125WV (CSA, US)	24-5-87
11-C1,2	EC301320	$\Delta$ MP/C. 4700PF (M) 250WV (CEE, UK, SAA)	24-9-122

12. FINAL ASSEMBLY BLOCK

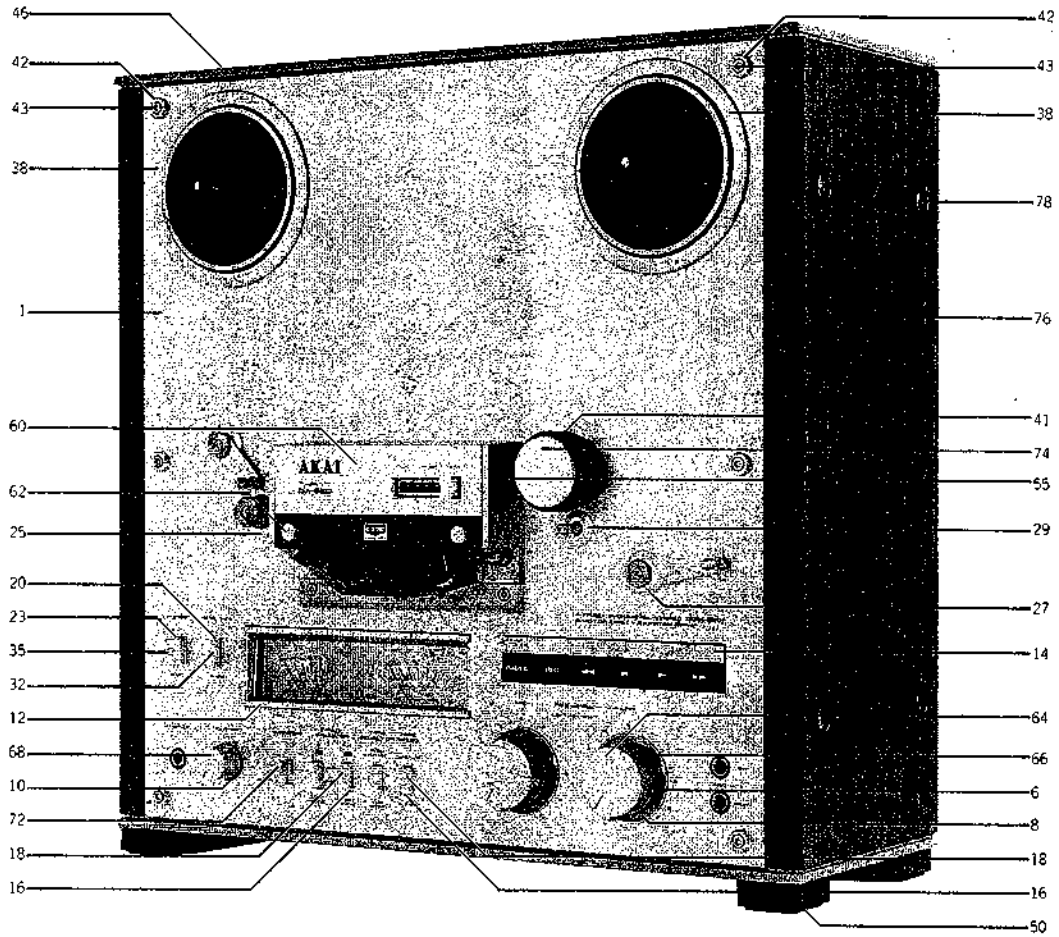

## FINAL ASSEMBLY BLOCK

Ref. No.	Parts No.	Description	Schematic No.	Ref. No.	Parts No.	Description	Schematic No.
<b>FRONT PANEL BLOCK</b>							
12-1	BD314137	Front Panel Block Comp. GX-620 (U/T) (Except US)	TG-6053	12-66	SK316097	Double Knob (Lower)	TG-6030
12-2x	BD318631	Front Panel Block Comp. GX-620-US	TG-6053	12-67x	SK316679	Double Knob (Lower-BL)	TG-6030
12-3x	BD314255	Front Panel Block Comp. GX-620-BL	TG-6053	12-68	SK314220	Knob (C) Part GX-620	TG-6032
12-4x	SE316069	Pitch Control Escutcheon (US)	TG-6004	12-69x	SK314259	Knob (C-BL) Part GX-620-BL	TG-6032
12-5x	SE316070	Timer Escutcheon (US)	TG-6005	12-70x	SK316099	Knob (D) (US)	TG-6033
12-6	SE316072	Vol. Escutcheon (A) (U/T, US)	TG-6007	12-71x	SK316100	Knob (E) (US)	TG-6034
12-7x	SE316661	Vol. Escutcheon (A-BL)	TG-6007	12-72	SK316111	Lever Knob	TG-6045
12-8	SZ316115	Decoration Ring	TG-6048	12-73x	SK316682	Lever Knob (BL)	TG-6045
12-9x	SZ316683	Decoration Ring (BL)	TG-6048	12-74	SK314229	Pinch Roller Cap Part GX-620	TD-6013
12-10	SE316071	Vol. Escutcheon (B)	TG-6006	12-75x	SK314260	Pinch Roller Cap (BL) Part GX-620-BL	TD-6013
12-11x	SE319521	Vol. Escutcheon (B-BL)	TG-6006	12-76	SP316101	Side Cover (A)	TG-6035
12-12	SE316076	Meter Escutcheon	TG-6011	12-77x	SP316681	Side Cover (BL)	TG-6035
12-13x	SE316665	Meter Escutcheon (BL)	TG-6011	12-78	ZS318423	Screw (B), w/Spot Facing Washer	TH-6057
12-14	SE316077	Operation Escutcheon	TG-6012	12-79x	EW315767	Δ AC Cord Set CEE 2 Cores (CEE)	26-3-72
12-15x	SE316666	Operation Escutcheon (BL)	TG-6012	12-80x	EW322400	Δ AC Cord Set BASEC 2 Cores (UK)	26-3-73
12-16	SE316079	SW. Escutcheon (A)	TG-6013	12-81x	EW322401	Δ AC Cord Set SAA 2 Cores (SAA)	26-3-77
12-17x	SE316667	SW. Escutcheon (A-BL)	TG-6013	12-82x	SA312529	Rubber Foot (A-2) Part	LE-6739
12-18	SE316081	SW. Escutcheon (B-1)	TG-6014				
12-19x	SE316668	SW. Escutcheon (B-1-BL)	TG-6014				
12-20	SE316118	SW. Escutcheon (B-2)	TG-6014				
12-21x	SE316669	SW. Escutcheon (B-2-BL)	TG-6014				
12-22x	SE316081	SW. Escutcheon (B-1)	TG-6014				
12-23	SE316084	Power Knob Escutcheon	TG-6017				
12-24x	SE316671	Power Knob Escutcheon (BL)	TG-6017				
12-25	SE316073	Tape Roller Escutcheon	TG-6008				
12-26x	SE316662	Tape Roller Escutcheon (BL)	TG-6008				
12-27	SE316074	Tension Arm Escutcheon	TG-6009				
12-28x	SE316663	Tension Arm Escutcheon (BL)	TG-6009				
12-29	SE316075	Capstan Escutcheon	TG-6010				
12-30x	SE316664	Capstan Escutcheon (BL)	TG-6010				
12-31x	ZG316083	Button Spring	TG-6016				
12-32	SK316082	Knob (A)	TG-6015				
12-33x	SK316670	Knob (A-BL)	TG-6015				
12-34x	ZG316086	Power Button Spring	TG-6019				
12-35	SK316085	Knob (B)	TG-6018				
12-36x	SK316672	Knob (B-BL)	TG-6018				
12-37x	ZW316688	Nylon Rivet (Male) 4x5	2-7-57				
12-38	SE315931	Reel Table Escutcheon (2-C)	TD-6021				
12-39x	SE315577	Reel Table Escutcheon (2-D)	TD-6021				
12-40x	ZW575730	Speed Nut (P Type) (3)	6-3-6				
<b>FINAL ASSEMBLY BLOCK</b>							
12-41	MP582164	Pinch Roller D=42	TD-1034				
12-42	ZW315917	Decoration Washer	TG-6020				
12-43	ZS613901	Panel Screw	CW-6031				
12-44x	ZW316673	Decoration Washer (BL)	TG-6020				
12-45x	ZS306435	Panel Screw (C)	CW-6031				
12-46	SP316087	Cover	TG-6021				
12-47x	SP316674	Cover (BL)	TG-6021				
12-48x	ZS316650	Screw, Pan 4x8					
12-49x	ZS201778	Screw, Pan Head 4x8 (Black)					
12-50	SA314222	Square Foot Part GX-620	TG-6022				
12-51x	ZS520525	Screw, Bind 4x25 (Black)					
12-52x	SP316103	Back Board (U) (U/T)	TG-6036,6037				
12-53x	SP316104	Back Board (C, A) (CSA, US)	TG-6036,6038				
12-54x	SP316105	Back Board (E, B) (CEE, UK, SAA)	TG-6036,6039				
12-55	SC319608	Head Cover Assy GX-620					
12-56x	SC320035	Head Cover Assy GX-620-BL					
12-57x	ZS421806	Screw, Pan 3x8					
12-58x	SP316094	Decoration Panel	TG-6027				
12-59x	ZS316114	Panel Screw	TG-6047				
12-60	BZ314139	Head Cover Plate Assy GX-620					
12-61x	BZ314257	Head Cover Plate Assy GX-620-BL					
12-62	ZS322429	Decoration Screw (B)	CF-6210				
12-63x	ZS322430	Decoration Screw (B-BL)	CF-6210				
12-64	SK314221	Double Knob (Upper) Part GX-620	TG-6028				
12-65x	SK314258	Double Knob (Upper-BL) Part GX-620-BL	TG-6028				

When ordering parts, please describe Parts Number, Description, and Model Number in detail.

# INDEX

Parts No.	Ref. No. & Symbol No.	Parts No.	Ref. No. & Symbol No.	Parts No.	Ref. No. & Symbol No.	Parts No.	Ref. No. & Symbol No.	Parts No.	Ref. No. & Symbol No.
BA314235	10-1	EF309388	10-F5	EV313538	9-VR5	SE316665	12-13x	ZS421806	12-57x
BA314237	10-2	EF309391	10-F3	EV315540	9-VR6	SE316666	12-15x	ZS422076	5-13
BA314238	10-4	EF309391	10-F5	EV315541	9-VR4	SE316667	12-17x	ZS422076	7-3
BA318811	10-3	EF310229	10-F4	EV315751	9-VR1,2	SE316668	12-19x	ZS422076	8-11
BA319390	9-1	EF311839	10-F2	EV315753	9-VR3	SE316669	12-21x	ZS424056	4-12
BA319392	9-2	EF593706	6-25x	EV315928	8-44x	SE316671	12-24x	ZS432674	8-39x
BD314137	12-1	EF593706	10-F3	EW305691	6-20x	SE319521	12-11x	ZS435273	6-10
BD314255	12-3x	EF601942	10-F5	EW306428	6-19	SK314220	12-68	ZS447761	6-14x
BD318631	12-2x	EF623103	10-F2	EW315767	12-79x	SK314221	12-64	ZS447761	7-7x
BH314075	2-1x	EF623103	10-F4	EW322400	12-80x	SK314229	12-74	ZS447840	6-17
BI314142	5-1	EI304165	10-IC4,5	EW322401	12-81x	SK314258	12-65x	ZS483502	8-36
BI673626	5-9	EI304166	10-IC6	EZ631945	6-21	SK314259	12-69x	ZS499331	5-4
BK314428	8-53	EI306141	9-IC1	HA316007	2-13	SK314260	12-75x	ZS520525	12-51x
BL314071	8-41	EI308936	10-IC1	HA316009	2-18	SK316082	12-32	ZS527681	8-65
BL314141	5-14	EI316170	10-IC2,3	HA321735	2-22	SK316085	12-35	ZS539741	2-19x
BM308310	3-1x	EJ249333	9-P1	HE311139	2-21	SK316097	12-66	ZS558101	5-7
BM587518	4-1	EJ249366	9-P2	HP318522	2-10	SK316099	12-70x	ZS592378	8-3
BR587542	4-2	EJ249467	6-16	HR308148	2-17	SK316100	12-71x	ZS608308	3-4x
BR587553	4-3	EJ262732	6-15	HZ301366	2-11	SK316111	12-72	ZS608321	5-19
BT316131	6-7	EJ301513	6-12x	HZ316005	2-8	SK316670	12-33x	ZS608411	2-12
BT316133	6-9x	EJ306289	9-J1	HZ316006	2-15	SK316672	12-36x	ZS608501	2-16
BT316134	6-8x	EJ306985	9-J3	HZ316008	2-20	SK316679	12-67x	ZS613901	12-43
BZ308315	3-5	EJ307274	6-5	HZ532710	2-5	SK316682	12-73x	ZW260010	5-8
BZ314139	12-60	EJ316129	2-24x	MB316029	8-51	SK597633	3-3	ZW260256	5-15
BZ314257	12-61x	EJ316130	2-25x	MB527556	8-47	SP316087	12-46	ZW263946	7-4x
EC301320	11-C1,2	EJ316156	9-J2	MB606712	8-9	SP316094	12-58x	ZW265522	2-7
EC306420	9-C28	EL316167	8-59	MB665561	5-5	SP316101	12-76	ZW270088	4-8
EC306438	9-C14	EM316135	7-5	MB668801	8-33	SP316103	12-52x	ZW270088	8-6
EC313534	10-C44,45	EM316689	7-6x	MC316116	8-48	SP316104	12-53x	ZW270156	8-42
EC314688	11-C1	EO301467	9-L1	MC316685	8-49x	SP316105	12-54x	ZW270191	5-2
EC316065	6-18	EO316141	9-VL2	MH316004	2-4	SP316674	12-47x	ZW273756	6-4
EC316149	9-C29	EO316142	9-L2	MH316022	8-25	SP316681	12-77x	ZW273756	8-16x
EC316150	9-C44	EO346230	9-VL1	MI691097	5-12	SZ316115	12-8	ZW273756	10-6
EC316182	10-C1	EO346230	9-VL3	ML314426	8-32	SZ316683	12-9x	ZW274026	8-19
EC316184	10-C7	EO383365	9-T1	ML692504	5-22	ZG232121	5-6	ZW290283	8-4
EC316191	10-C55to68	EP300132	10-RL1to3	ML694506	5-26	ZG308734	8-5	ZW305533	5-11
EC316192	10-C51	EP308949	10-RL4	MP582164	8-63	ZG312947	5-20	ZW315917	12-42
EC316193	10-C52	EP308973	9-RL1	MP582164	12-41	ZG312998	8-34	ZW316011	2-26
EC316194	10-C49,50	EP309056	8-2	MR691942	8-23	ZG316040	8-43	ZW316136	8-38
EC316195	10-C47	EP315918	8-10	MS342000	2-5	ZG316083	12-31x	ZW316673	12-44x
EC316230	10-C4	EP316121	8-7	MT314987	8-31	ZG316086	12-34x	ZW316688	12-37x
EC321146	10-C71	ER233638	10-R28	MT436860	4-11	ZG321132	8-1	ZW376391	8-64
EC321173	9-C70	ER300820	10-CR1to7	MT534666	4-4	ZG466312	2-6	ZW413188	8-17x
EC551160	11-C1	ER308898	9-FR1	MT534677	4-7	ZG540617	4-6	ZW413267	6-11
EC558202	9-V-C1	ER308955	10-R98	MT534688	4-9	ZG580522	8-14	ZW413278	3-9
ED224550	10-D47to49	ER309092	10-R96	MV249074	8-40x	ZG659608	5-18	ZW413278	8-18
ED281621	10-D50	ER318415	10-R97	MV368886	3-7	ZG672478	8-46	ZW420682	8-12
ED306109	10-D46	ER663298	10-R27	MZ397181	8-13	ZS201508	3-6	ZW462205	8-20x
ED307236	10-D6	ER666854	10-R4	MZ580680	8-37	ZS201778	12-49x	ZW535094	5-24
ED308941	10-D3,4	ES306430	6-13x	MZ597690	3-8	ZS304464	2-23	ZW560226	5-23
ED308945	10-D1,2	ES309059	8-61	MZ674256	5-3	ZS304806	2-14	ZW575730	12-40x
ED308952	10-D20,21	ES309094	10-SW1	SA312529	12-82x	ZS306435	12-45x	ZW575763	5-17
ED308952	10-D31	ES310333	8-62x	SA314222	12-50	ZS316114	12-59x	ZW580498	5-16
ED308952	10-D34to41	ES315747	9-SW6	SB316162	8-54	ZS316119	8-60	ZW597622	3-2
ED308953	9-D2	ES316117	8-45x	SB316163	8-55	ZS316650	12-48x	ZW676045	8-24
ED308953	9-D4,5	ES316158	9-SW1to4	SB316164	8-56	ZS318423	12-78		
ED309069	10-D5	ES316169	10-SW1	SB316165	8-57	ZS322429	12-62		
ED310585	7-1	ES562465	8-35	SB316166	8-58	ZS322430	12-63x		
ED316143	10-D29	ES573478	8-29	SC319608	12-55	ZS323728	8-28		
ED316143	10-D32	ET304181	9-TR6,7	SC320035	12-56x	ZS325495	6-1		
ED316143	10-D43to45	ET307349	9-TR15	SE315577	12-39x	ZS325495	7-2		
ED316143	10-D51	ET307349	10-TR1	SE315931	12-38	ZS325495	8-22x		
ED318292	9-D1	ET308937	10-TR23	SE316069	12-4x	ZS379350	2-3		
ED318292	9-D3	ET308937	10-TR25	SE316070	12-5x	ZS379350	5-21		
ED318292	9-D8to10	ET308947	6-2	SE316071	12-10	ZS380046	8-21x		
ED510772	10-D7,8	ET310832	10-TR24	SE316072	12-6	ZS411660	5-25		
ED560913	9-D6,7	ET313717	9-TR13	SE316073	12-25	ZS413201	2-9		
ED560913	9-D11	ET316171	10-TR3to9	SE316074	12-27	ZS413201	3-10		
ED560913	10-D9to19	ET316171	10-TR15to22	SE316075	12-29	ZS413201	8-15		
ED560913	10-D22to28	ET352146	9-TR1to3	SE316076	12-12	ZS413245	8-52x		
ED560913	10-D30	ET352146	9-TR8to10	SE316077	12-14	ZS417137	8-50x		
ED560913	10-D33	ET375603	10-TR2	SE316079	12-16	ZS417150	2-2x		
ED560913	10-D42	ET554657	10-TR10to14	SE316081	12-18	ZS417150	8-27x		
ED560913	10-D52to55	ET639437	9-TR4,5	SE316081	12-22x	ZS417216	8-8		
EF306950	6-23x	ET639437	9-TR11,12	SE316084	12-23	ZS419670	4-10		
EF306954	6-24x	ET639437	9-TR14	SE316118	12-20	ZS419670	8-30		
EF308847	10-F2	ET639437	9-TR16to20	SE316661	12-7x	ZS421740	6-6		
EF309387	6-22	ET666404	10-TR26	SE316662	12-26x	ZS421806	6-3		
EF309387	10-F4	EV302718	10-VR1	SE316663	12-28x	ZS421806	8-26		
EF309388	10-F3	EV309071	10-VR2	SE316664	12-30x	ZS421806	10-5		



---

SECTION 3

**SCHEMATIC DIAGRAM**

1. SCHEMATIC DIAGRAM OF ICs
2. GX-620 NO. 2-1 1852038A POWER & SYS. CON SCHEMATIC DIAGRAM
3. GX-620 NO. 2-2 1852039A AMP SCHEMATIC DIAGRAM

LA-4170

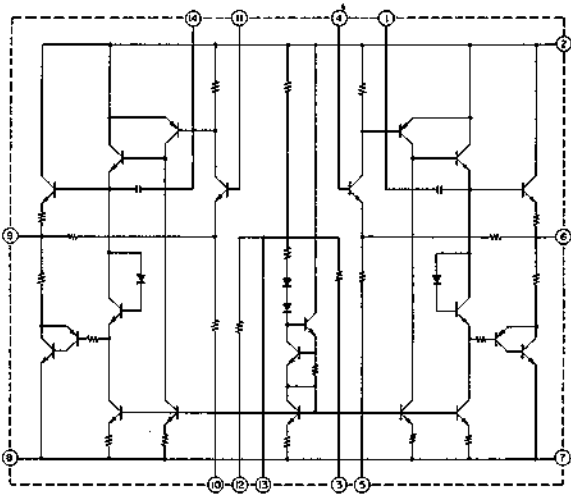

MB-418

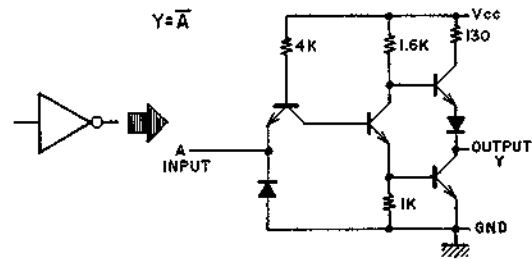
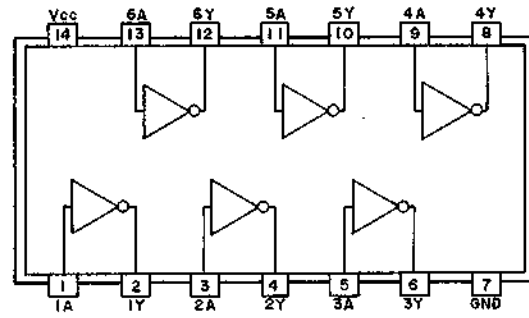

LB-1270

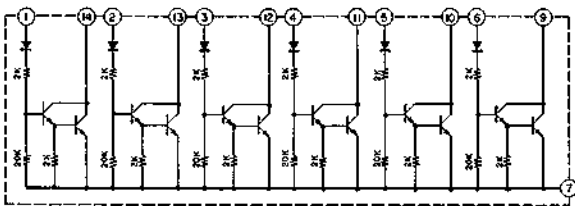

M54410P

MB-400

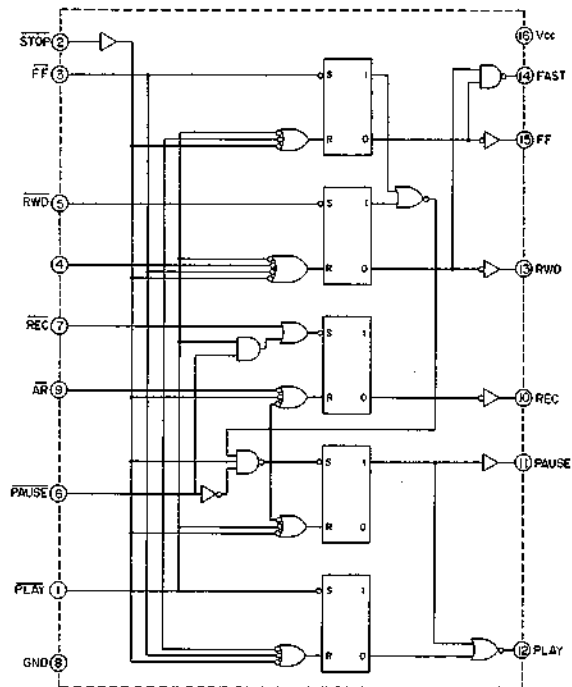
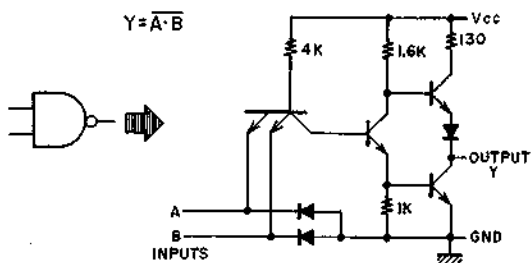
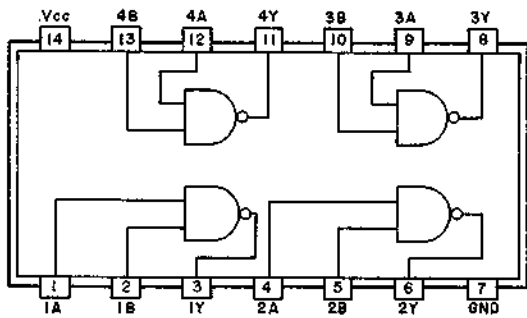

GX-620

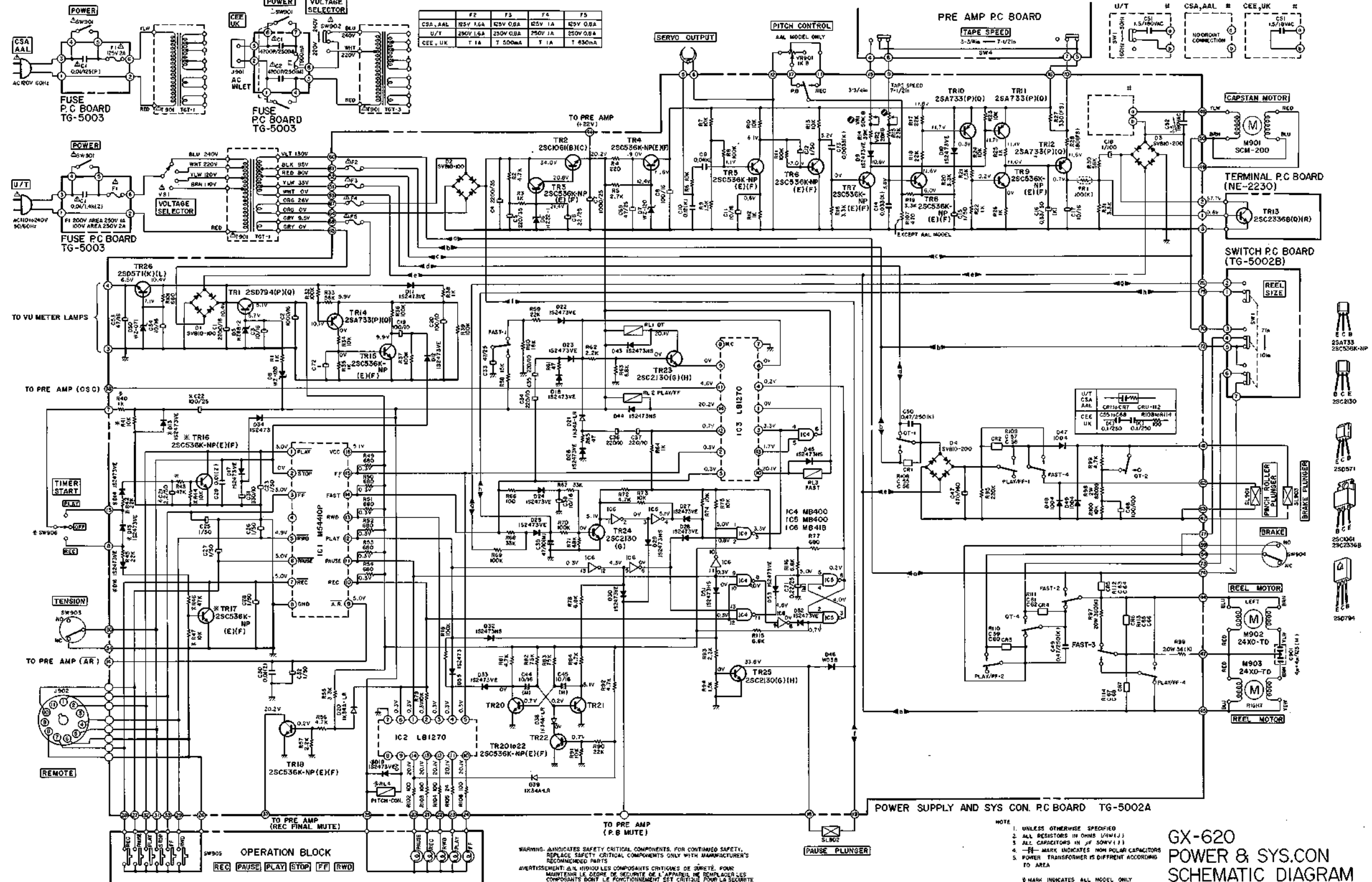

WARNING: INDICATES SAFETY CRITICAL COMPONENTS. FOR CONTINUED SAFETY, REPLACE SAFETY CRITICAL COMPONENTS ONLY WITH MANUFACTURER'S RECOMMENDED PARTS.  
 AVERTISSEMENT: AIL VIBRER LES COMPOSANTS CRITIQUES DE SÉCURITÉ. POUR MAINTENIR LE DEGRÉ DE SÉCURITÉ DE L'APPAREIL, NE REMPLACER LES COMPOSANTS SONT LE FONCTIONNEMENT EST CRITIQUE POUR LA SÉCURITÉ QUE PAR DES PIÈCES RECOMMANDÉES PAR LE FABRICANT.

- NOTE
1. UNLESS OTHERWISE SPECIFIED
  2. ALL RESISTORS IN OHMS (Ω/W/J)
  3. ALL CAPACITORS IN μF (50V/1)
  4. —|— MARK INDICATES NON POLAR CAPACITORS
  5. POWER TRANSFORMER IS DIFFERENT ACCORDING TO AREA
- 8 MARK INDICATES ALL MODEL ONLY

GX-620  
 POWER & SYS.CON  
 SCHEMATIC DIAGRAM  
 No.2-1 1582038A





GX-620

PRE AMP P.C BOARD T6-5001A

REC MODE		
	7-1/2in	3-3/4in
TR12	0.2V	0.2V
TR6	15.2V	14.1V
TR6,7	15.1V	12.3V
	0.2V	0.2V
TR1	1.7V	0.5V
	1.4.5V	1.1.8V
	66.8VAC	5.4.3VAC
	111.2VAC	91.3VAC

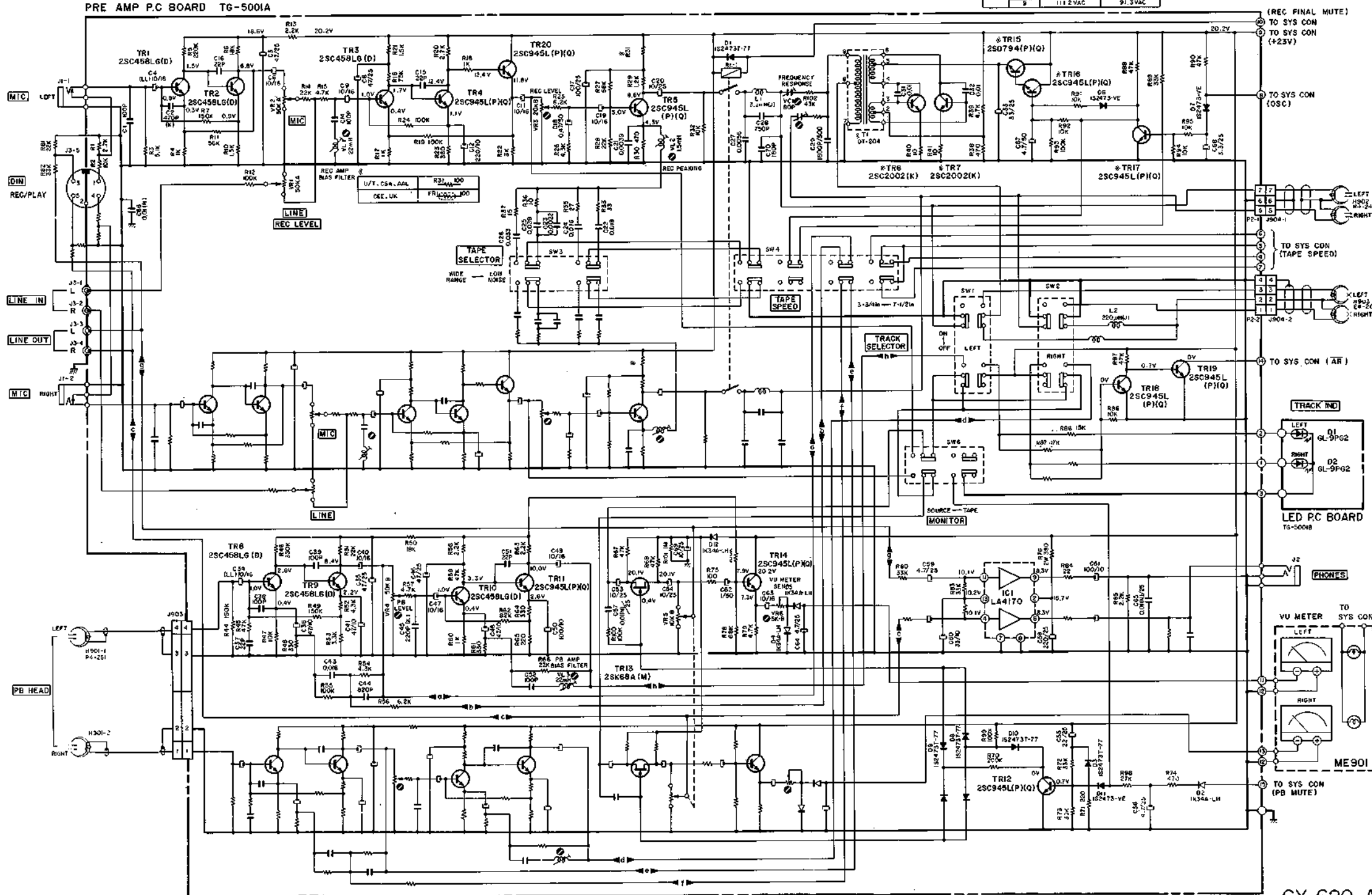

NOTE  
 UNLESS OTHERWISE SPECIFIED  
 ALL RESISTORS IN OHMS (R100K)  
 ALL CAPACITORS IN  $\mu$ F (SUPPLY)  
 ALL LOW LEAKAGE CAPACITORS

GX-620 AMP  
 SCHEMATIC DIAGRAM  
 NO.2-2 1582039A