

# SERVICE MANUAL

## PARTS LIST

**MODEL GX-266D**

**AKAI**



**AKAI STEREO TAPE DECK**

**MODEL GX-266D**

**SECTION 1 SERVICE MANUAL** .....

**SECTION 2 PARTS LIST** .....

## I . TECHNICAL DATA

TRACK SYSTEM	4 track 2 channel stereo/monaural system
REEL CAPACITY	Up to 7" reel
TAPE SPEED	7-1/2 and 3-3/4 ips. ( $\pm 0.5\%$ )
WOW & FLUTTER	Less than 0.06% at 7-1/2 ips. Less than 0.09% at 3-3/4 ips.
FREQUENCY RESPONSE	30 to 25,000 Hz $\pm 3$ dB at 7-1/2 ips. using LN tape 30 to 19,000 Hz $\pm 3$ dB at 3-3/4 ips. using LN tape 30 to 26,000 Hz $\pm 3$ dB at 7-1/2 ips. using WR tape 30 to 20,000 Hz $\pm 3$ dB at 3-3/4 ips. using WR tape
DISTORTION (1,000 Hz "0" VU)	Less than 0.5% at 7-1/2 ips. Less than 1.0% at 3-3/4 ips.
SIGNAL TO NOISE RATIO	Better than 56 dB (Measured via tape with peak recording level of +6 VU)
ERASE RATIO	Better than 70 dB
BIAS FREQUENCY	100 kHz
HEADS	(6): Two GX Playback Heads, Two GX Recording heads, Two Erase heads
MOTORS	(3): One AC Servo Capstan Motor Two Eddy Current Reel Motor
F.F & Rewind Time	90 sec. using 1,200 ft. tape
OUTPUT JACKS	Line (2): 0-0.775V (MAX 0 VU) required load impedance: more than 20 k ohms Phone (1): 0-100 mV/8 ohms (MAX 0 VU)
INPUT JACKS	Microphone (2): 0.25 mV/2.4 k ohms required microphone impedance: 600 ohms Line (2): 70 mV/100 k ohms
SEMICONDUCTORS	Transistors: 61, Diodes: 92
DIMENSIONS	404 (W) x 470 (H) x 250 (D)mm, (15.9 x 18.5 x 9.8") 440 (W) x 470 (H) x 250 (D)mm : With Wood Side Plate (17.3 x 18.5 x 9.8")
WEIGHT	18.3 kg (40.4 lbs.) 20.6 kg (45.5 lbs.) : With Wood Side Plate
POWER REQUIREMENTS	110/120/220/240V, 50/60 Hz Switchable

\* For improvement purposes, specification and design are change without notice.

## II . DISMANTLING OF UNIT

In case of trouble, etc. necessitating disassembly, please disassemble in the order shown in photographs. Reassemble in reverse order.

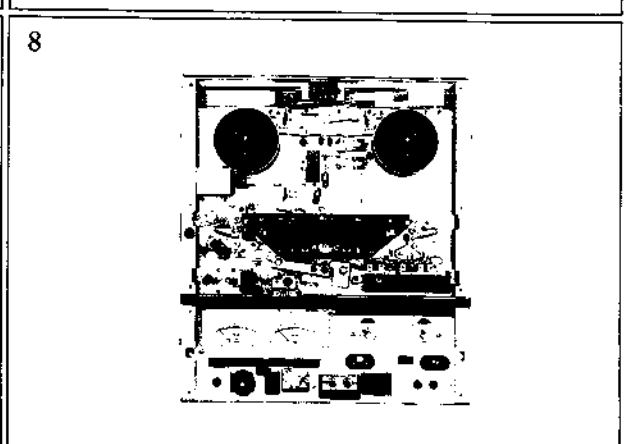
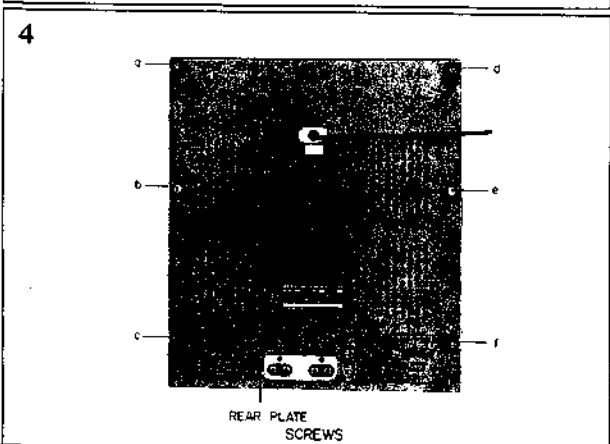
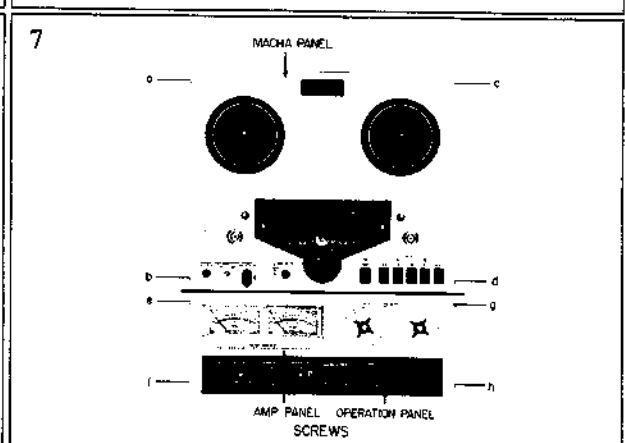
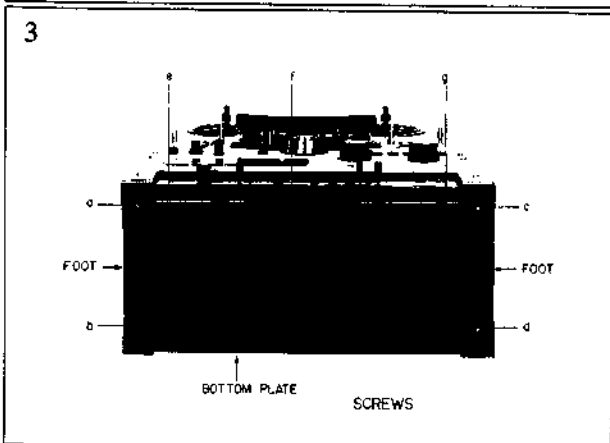
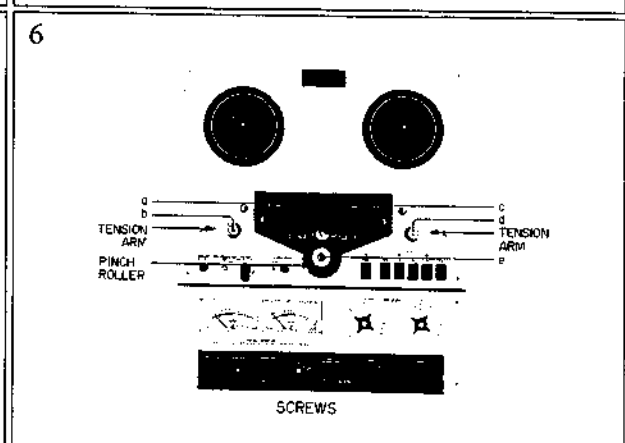
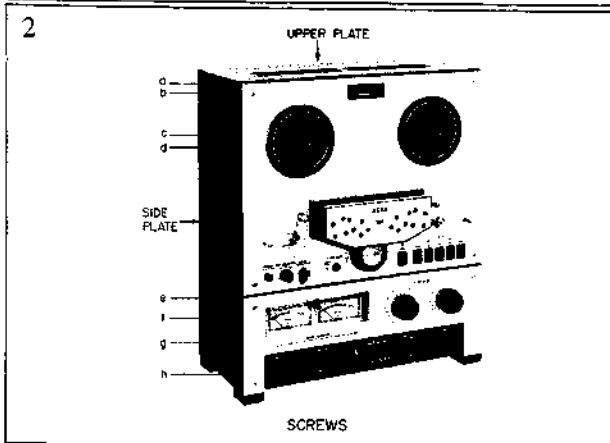
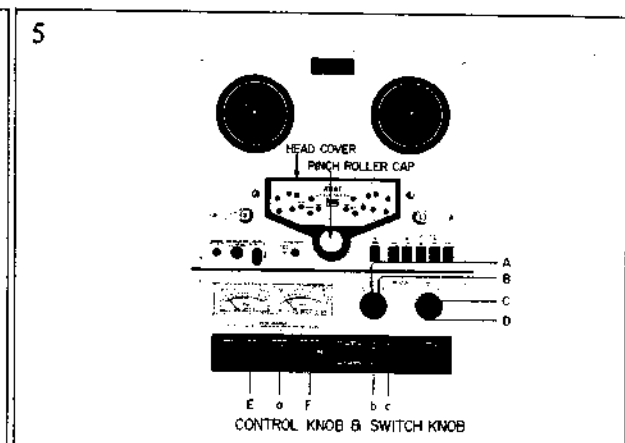
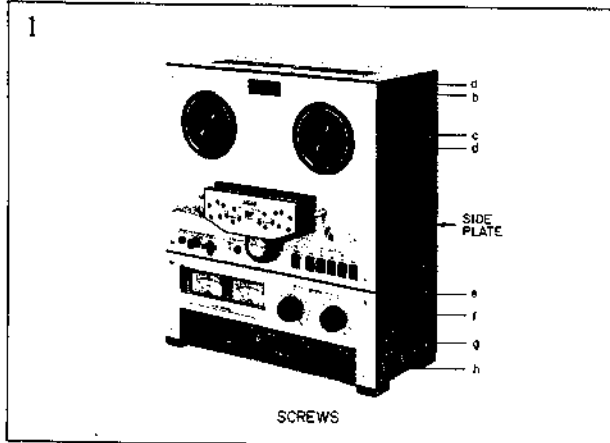

### III . CONTROLS

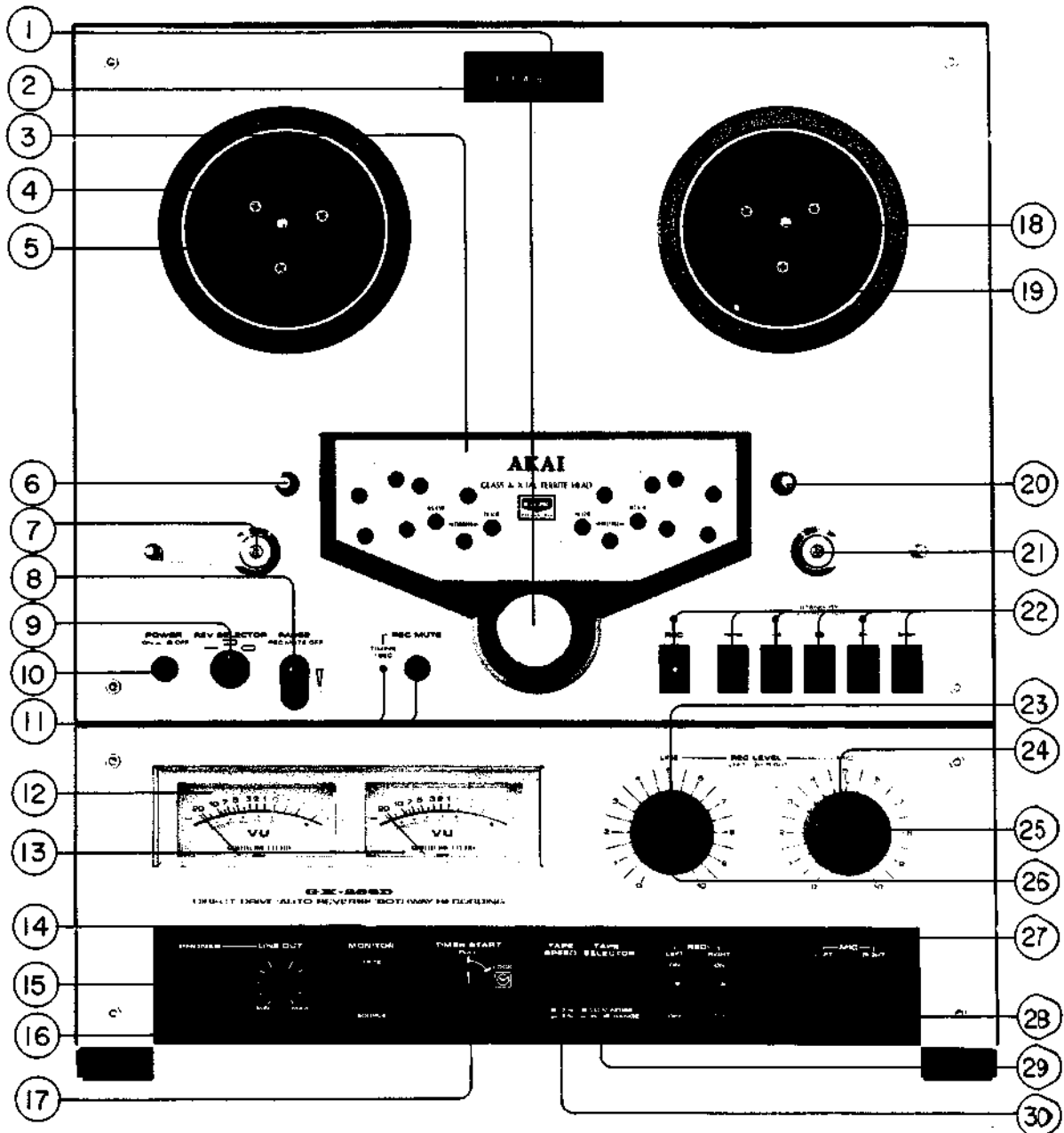

- |   |  |
|---|--|
| 1. INDEX COUNTER AND RESET BUTTON             | 16. LINE OUTPUT/HEADPHONE OUTPUT CONTROLS<br>(LINE OUT-PHONES) |
| 2. PINCH ROLLER                               | 17. TIMER START SWITCH (TIMER START)                           |
| 3. HEAD COVER                                 | 18. REEL RETAINER  |
| 4. SUPPLY REEL TABLE                          | 19. TAKE-UP REEL TABLE   |
| 5. REEL RETAINER                              | 20. TAPE GUIDE   |
| 6. TAPE GUIDE (SENSING POLE: FORWARD→REVERSE) | 21. TENSION ARM (SENSING POLE: REVERSE→FORWARD)                |
| 7. TENSION ARM                                | 22. OPERATION BUTTONS  |
| 8. PAUSE LEVER (PAUSE)/REC MUTE OFF           | 23. MEMORY MARKER (FOR LINE-IN)                                |
| 9. REVERSE SELECTOR (REV SELECTOR)            | 24. MEMORY MARKER (FOR MIC-IN)                                 |
| 10. POWER SWITCH (POWER)                      | 25. MICROPHONE INPUT CONTROLS (REC LEVEL-MIC)                  |
| 11. RECORDING MUTE SWITCH/TIMING LAMP         | 26. LINE INPUT CONTROLS (REC LEVEL-LINE)                       |
| 12. VU METER (FOR LEFT CHANNEL)               | 27. MICROPHONE JACK (MIC)                                      |
| 13. VU METER (FOR RIGHT CHANNEL)              | 28. RECORDING LEVER (REC)                                      |
| 14. MONITOR SWITCH (MONITOR)                  | 29. TAPE SELECTOR  |
| 15. HEADPHONE JACK (PHONES)                   | 30. TAPE SPEED SELECTOR  |

## IV . PRINCIPAL PARTS LOCATION

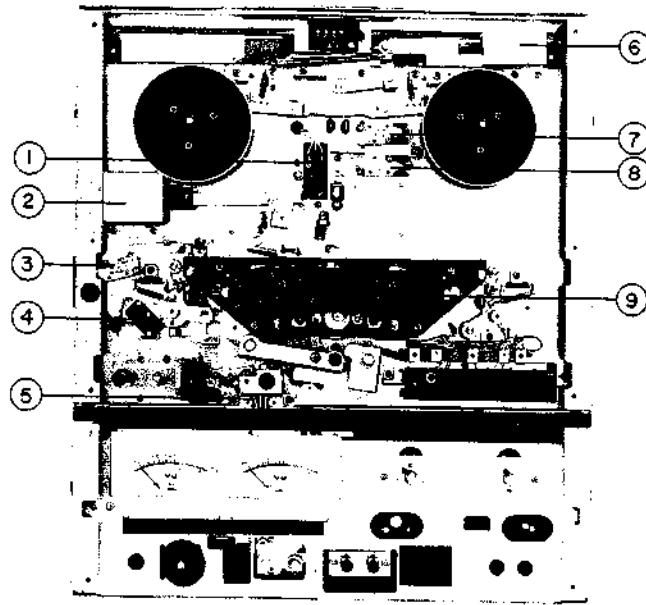

Front View

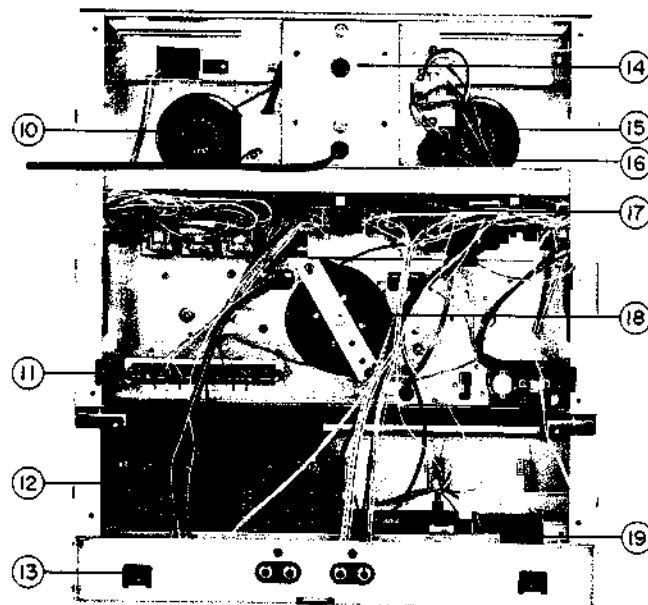

Rear View

1. PINCH ROLLER MICRO SWITCH SW-905
2. PINCH ROLLER PLUNGER SOLENOID SL-3
3. PAUSE MICRO SWITCH SW-903 & SW-907
4. TENSION MICRO SWITCH SW-904
5. MUTE SWITCH P.C BOARD NE-2228
6. BRAKE PLUNGER SOLENOID SL-901
7. BRAKE MICRO SWITCH SW-906
8. REEL MOTRO MICRO SWITCH SW-908
9. HEAD BLOCK
10. RIGHT REEL MOTOR 24XO-MR

11. OPERATION P.C BOARD NE-2239
12. MIC AMP P.C BOARD NE-5223
13. AMP P.C BOARD NE-5222
14. POWER TRANSFORMER NET-11
15. LEFT REEL MOTOR 24XO-MR
16. VOLTAGE SELECTOR
17. SYSTEM CONTROL P.C BOARD NE-1213
18. CAPSTAN MOTOR SCM2-24KJ
19. REV PLUNGER SOLENOID SL-902

## V. MECHANISM ADJUSTMENT

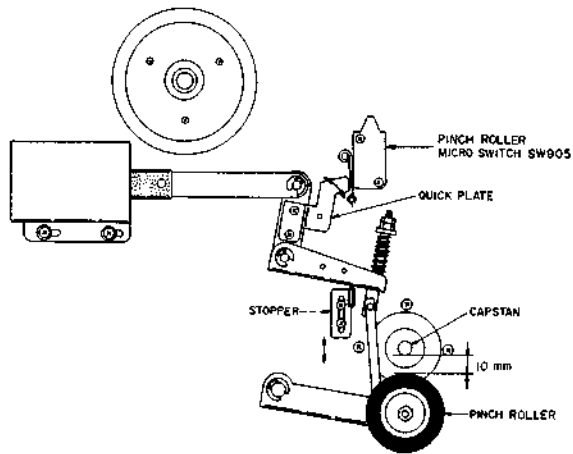

Fig. 1

### 1. PINCH ROLLER POSITION ADJUSTMENT AT STOP MODE (Refer to Fig. 1)

- 1) Remove head block.
- 2) Adjust Stopper so that the clearance between Pinch Roller and Capstan Shaft is 10mm.

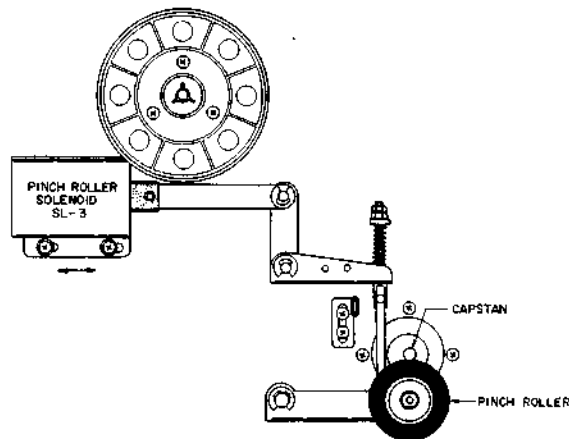

Fig. 2

### 2. POSITION ADJUSTMENT OF PINCH ROLLER SOLENOID SL-3 (Refer to Fig. 2)

- 1) Remove head block.
- 2) Insert a 4.2 mm gauge (a U type washer etc.) between the P Plunger Lever and P Joint (Refer to Fig. 3).
- 3) Set the deck to playback mode and fix Pinch Roller Solenoid at position at which the pinch Roller begins to rotate.

### 3. PINCH ROLLER PRESSURE ADJUSTMENT (Refer to Fig. 3)

Adjust Pinch Roller Pressure Adjustment Nut so that pinch roller pressure is 1.2 kg.

### 4. POSITION ADJUSTMENT OF QUICK PLATE (Refer to Fig. 1)

Adjust Quick Plate position so that at stop mode, the Pinch Roller Microswitch operates properly, and the Quick Plate does not strongly hit against the body of the microswitch.

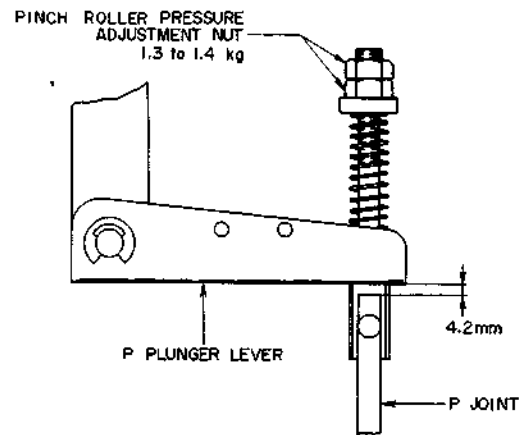

Fig. 3

### 5. POSITION ADJUSTMENT OF BRAKE SOLENOID SL-1 (Refer to Fig. 4)

Set the deck to playback mode, and fix Brake Solenoid at position at which the left and right brake levers display 180° angle relativity.

### 6. POSITION ADJUSTMENT OF BRAKE MICROSWITCH SW-906 (Refer to Fig. 4)

Set the deck to playback mode, and adjust Brake Solenoid Microswitch position so that the microswitch operates properly.

### 7. BRAKE TENSION ADJUSTMENT (Refer to Fig. 4)

Adjust Spring Stopper position so that the brake tension is 350 to 500g.

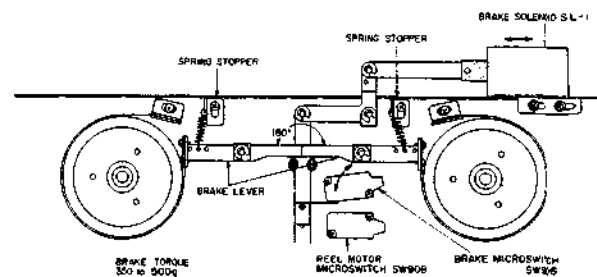

Fig. 4

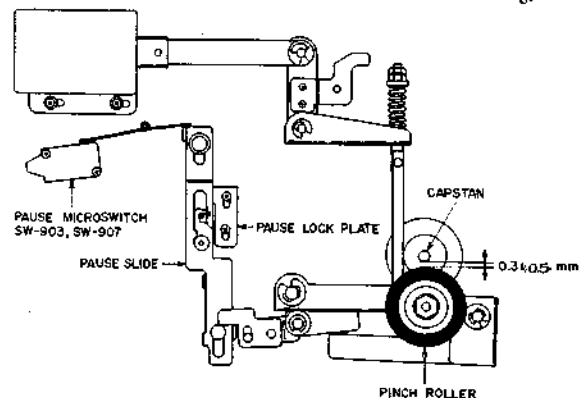

Fig. 5

## 8. PAUSE ADJUSTMENT (Refer to Fig. 5)

- 1) At playback mode, lock Pause Lever.
- 2) Adjust Pause Lock Plate position to obtain a 0.3 to 0.5 mm clearance between Pinch Roller and Capstan.
- 3) When making this adjustment, be careful that the clearance between Pinch Roller and Capstan does not exceed 0.5 mm.
- 4) Confirm that the Quick Tension Microswitch is pushed when the Pause Lever is depressed and if not, adjust with QT Lever B.

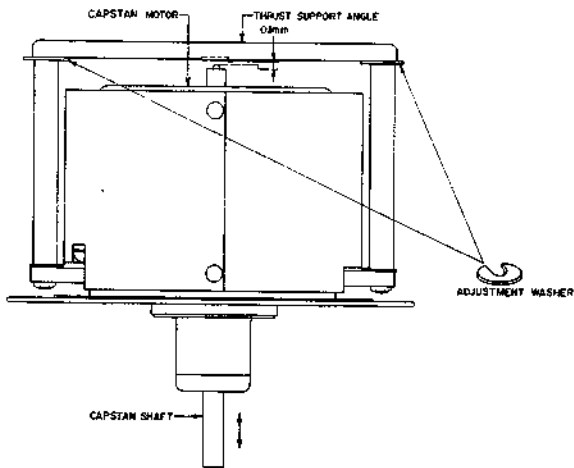

Fig. 6

## 9. CAPSTAN SHAFT LOOSE PLAY ADJUSTMENT (Refer to Fig. 6)

Adjust to obtain a clearance of about 0.1 mm between the capstan shaft and thrust support angle.

## 10. OPERATING POSITION ADJUSTMENT OF TENSION MICROSWITCH SW-904 (Refer to Fig. 7)

Adjust Tension Microswitch position so that when the Tension Arm drops, the microswitch operates perfectly to effect stop mode.

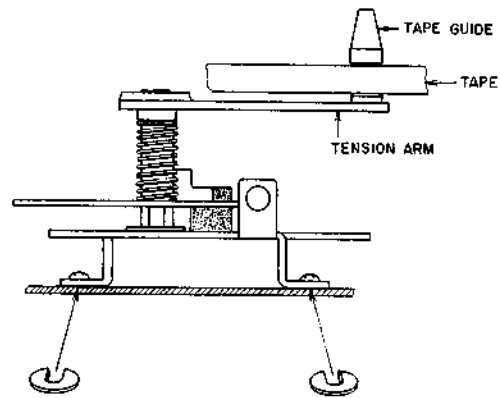

ADJUSTMENT WASHER  
\* LOWER THE GUIDE DOWN A LITTLE \* LIFT THE GUIDE UP A LITTLE

Fig. 8

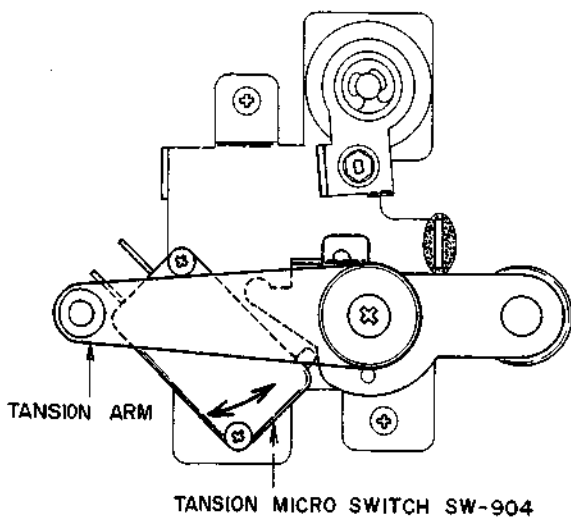

Fig. 7

## 11. TAPE GUIDE HEIGHT ADJUSTMENT (Refer to Fig. 8)

- 1) Adjust Tape Guide height so that the tape does not curl between tape guides on Head Base.
- 2) In case the tape guide is low, adjust by inserting a U Type Washer on the right side in Fig. 8, and in case it is high, adjust by inserting a washer on the left side.

## 12. REEL TABLE HEIGHT ADJUSTMENT (Refer to Fig. 9)

- 1) Load a tape and set the deck to F.FWD and REV modes. Adjust Reel Table height so that the tape winds on the center of the reels at both modes.
- 2) Tape should wind on center of reel regardless of type of reel used.

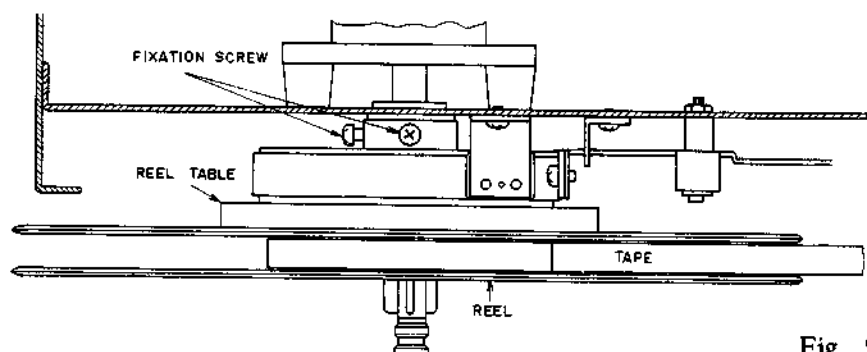

Fig. 9



## VI. HEAD ADJUSTMENT

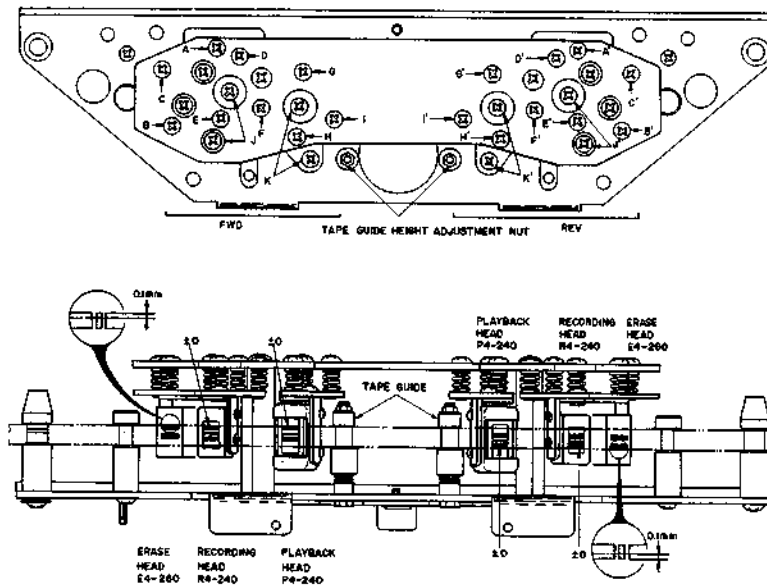

Fig. 10

Step	Adjustment Item	Test Tape Supply Signal	Mode	Adjustment Point	Remarks
1	Tape Guide Height	Optional	FWD	Tape Guide Height Adjustment Nut	1) Adjust so that tape travels smoothly and does not twist. 2) Do not thread tape over tension arm.
2	FWD Erase Head Height	Optional	FWD	(A)(B)(C)	Upper edge of channel 1 head core is 0.1mm higher than upper edge of tape.
3	FWD Recording Head Height	Optional	FWD	(D)(E)(F)	Upper edges of channel 1 head core and tape are the same height.
4	FWD Playback Head Height	Optional	FWD	(G)(H)(I)	Upper edges of channel 1 head core and tape are the same height.
5	FWD Playback Head Azimuth Alignment	8,000 Hz 3-3/4 ips Test Tape	FWD	(I)	Maximum output, both channels.
6	FWD Playback Head Gap Alignment	8,000 Hz 3-3/4 ips Test Tape	FWD	(K)	Adjust head gap surface so that there is no change in output level when tension is applied to the supply reel side.
7	FWD Recording Head Azimuth Alignment	Scotch #211 Tape, 15,000 Hz -20 dBm	REC	(F)	Maximum output, both channels.
8	FWD Recording Head Gap Alignment	Scotch #211 Tape, 15,000 Hz -20 dBm	REC	(J)	Adjust head gap surface so that there is no change in output level when tension is applied to the supply reel side.

Chart 1

- NOTES:
- 1) As perfect head adjustments are vital to tape deck performance, be sure that these adjustments are carried out properly.
  - 2) Be careful not to use a magnetized driver or other magnetized tools in the vicinity of the heads.
  - 3) Use only new tape as level variation is likely to occur when using old tape.
  - 4) Demagnetize heads with head demagnetizer before and after head adjustment.
  - 5) Set tape speed to 7-1/2 ips except.
  - 6) Adjustments outlined in Chart 1 are only for FWD side heads. However, adjustments for REV side heads are exactly the same.

## VII . ELECTRICAL ADJUSTMENT

### 1. DC POWER SUPPLY AND TAPE SPEED ADJUSTMENT



Fig. 11

- VR-1 1 k $\Omega$  DC Voltage Adj.  
 VR-2 50 k $\Omega$  3-3/4 ips Tape Speed Adj.  
 VR-3 10 k $\Omega$  7-1/2 ips Tape Speed Adj.

Step	Adjustment Item	Mode	Adjustment Point	Result	Remarks
1	DC Voltage	Stop	VR-1 1 k $\Omega$	24.0V	Measured at TP-1 on Sys. Con P.C Board
2	3-3/4 ips Tape Speed	FWD	VR-2 50 k $\Omega$	500 Hz $\pm 0.5\%$	1,000 Hz, 7-1/2 ips Test Tape. Tape Speed 3-3/4 ips.
3	7-1/2 ips Tape Speed	FWD	VR-3 10 k $\Omega$	1,000 Hz $\pm 0.5\%$	1,000 Hz, 7-1/2 ips Test Tape. Tape Speed 7-1/2 ips.

Chart 2

## 2. AMPLIFIER ADJUSTMENT

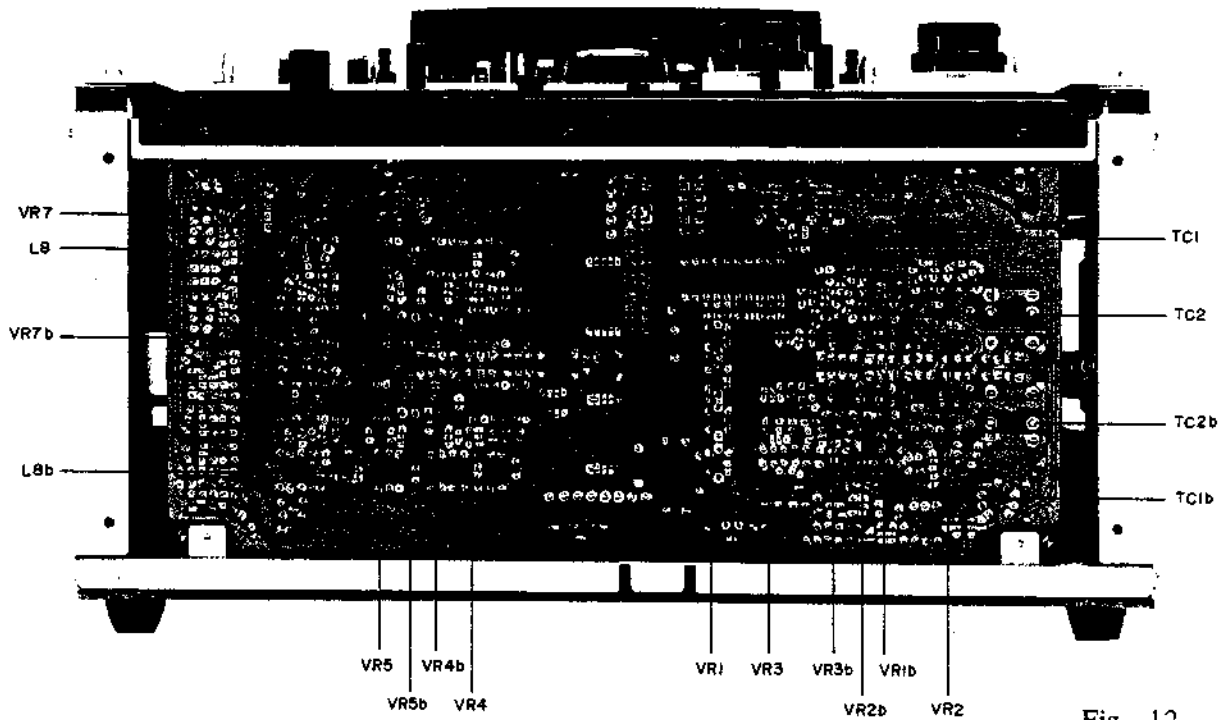

Fig. 12

VR-4	50 kB	FWD Playback Level Adj.
VR-5	50 kB	REV Playback Level Adj.
VR-7	1 kB	VU Meter Sensitivity Adj.
VR-1	1 kB	Monitor Level Adj.
VR-2	10 kB	FWD Recording Level Adj.
VR-3	10 kB	REV Recording Level Adj.
TC-2	80 PF	FWD Frequency Response Adj.
TC-1	80 PF	REV Frequency Response Adj.
L-8	23 mH	BIAS Leak Adj.

\* The letter "b" following an adjustment part number indicates "RIGHT CHANNEL".

Step	Adjustment Item	Test Tape Supply Signal	Mode	Adjustment Item	Result	Remarks
1	FWD Playback Level	700 Hz 7-1/2 ips 0 VU Test Tape	FWD	VR4 50 kB	0 ±0.5 dB (0.775V)	
2	REV Playback Level	700 Hz 7-1/2 ips 0 VU Test Tape	REV	VR5 50 kB	0 ±0.5 dB (0.775V)	
3	VU Meter Sensitivity	700 Hz 7-1/2 ips 0 VU Test Tape	FWD	VR7 1 kB	0 VU	
4	Monitor Level	1,000 Hz -21 dB (70 mV) Signal to Line Input	STOP	VR1 5 kB	0 dB (0 VU)	Line REC Volume maximum. Monitor Switch "SOURCE".
5	FWD Recording Level	Scotch #211 Tape 1,000 Hz 0 VU recording	FWD- REC	VR2 10 kB	0 ±0.5 dB (0.775V)	Monitor Switch "TAPE".
6	REV Recording Level	Scotch #211 Tape 1,000 Hz 0 VU recording	REV- REC	VR3 10 kB	0 ±0.5 dB (0.775V)	Monitor Switch "TAPE".
7	FWD Frequency Response	Scotch #211 Tape 1.5 kHz, 15 kHz -20 VU recording	FWD- REC	TC2 80 PF	1.5 kHz, 15 kHz flat	Tape Speed 3-3/4 ips. Recheck Recording Level.
8	REV Frequency Response	Scotch #211 Tape 1.5 kHz, 15 kHz -20 VU recording	REV- REC	TC1 80 PF	1.5 kHz, 15 kHz flat	Tape Speed 3-3/4 ips. Recheck Recording Level.
9	Bias Leak		REC	L8 23 mH	Less than -30 dB	Mic, Line Volume at Max.

Chart 3

- NOTES: 1) Set tape speed to 7-1/2 ips except in Steps 7 and 8.  
2) Tape Selector at "LOW NOISE"  
3) Monitor Switch at "TAPE" except in Step 4.  
4) Output Volume at maximum.  
5) New test tape should be used.

## VIII. DC RESISTANCE OF VARIOUS COILS

Part	Designation	DC Resistance
Main Motor	SCM2-24KJ	Between BLU-RED: 100 ohms Between YLW-GRN: 180 ohms Pick-up Coil: 635 ohms
Reel Motor	24XO-MR	Between BLU-RED: 74 ohms Between YLW-GRN: 1,660 ohms
Pinch Roller Solenoid	1660PTHT3	700 ohms
Brake Solenoid, REV Solenoid	1240PHT	590 ohms
Relay	L-24	1,600 ohms
Relay	MY4-0-US-AD4 DC24V	650 ohms
Oscillator Coil	OT-204	Between 1-3: 0.3 ohms Between 4-6: 0.7 ohms Between 7-9: 8.2 ohms
Erase Head	E4-260	3.5 ohms
Recording Head	R4-240	6.2 ohms
Playback Head	P4-240	220 ohms

Chart 4

\* The resistance values shown in this chart are average values.

SECTION 2

**PARTS LIST**

TABLE OF CONTENTS

1. HEAD BLOCK .....	23
2. MAIN MOTOR BLOCK .....	24
3. REEL MOTOR/TABLE BLOCK .....	25
4. OPERATION BLOCK .....	26
5. TENSION BLOCK .....	27
6. PINCH ROLLER PLUNGER BLOCK .....	29
7. MECHA ASSEMBLY BLOCK .....	31
8. P.C BOARDS .....	32
(1) AMP P.C BOARD (NE-5222) BLOCK .....	32
(2) SYS. CON P.C BOARD (NE-1213) BLOCK .....	32
(3) MIC AMP P.C BOARD (NE-5223) BLOCK .....	33
9. POWER SUPPLY BLOCK .....	35
10. AMP ASSEMBLY BLOCK .....	37
11. FINAL ASSEMBLY BLOCK .....	38
12. LIST OF INTERCHANGEABLE SEMICONDUCTORS .....	39
INDEX .....	40

Resistor and Capacitor which is not listed in this parts list, please refer to  
COMMON LIST FOR SERVICE PARTS.

3) MIC AMP P.C BOARD NE-5223

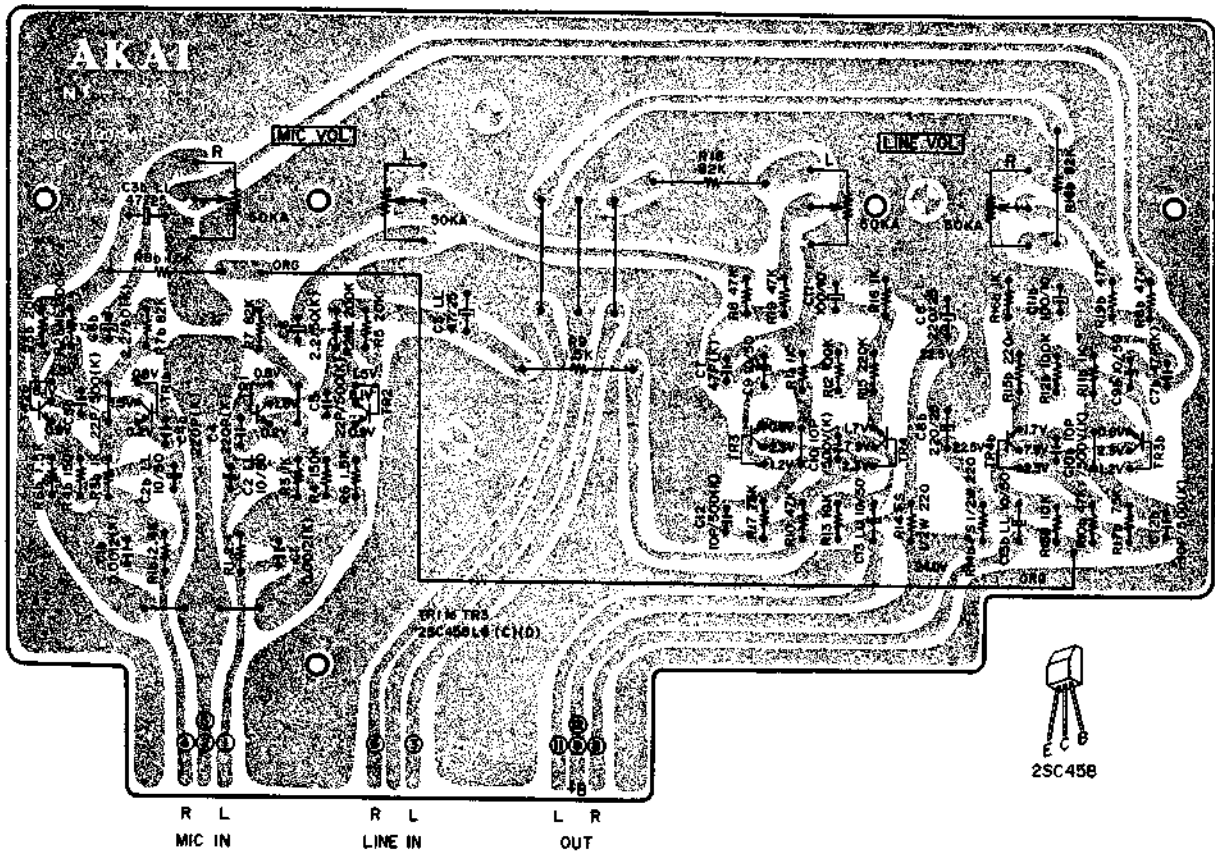

2) SYS. CON P.C BOARD NE-1213

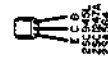
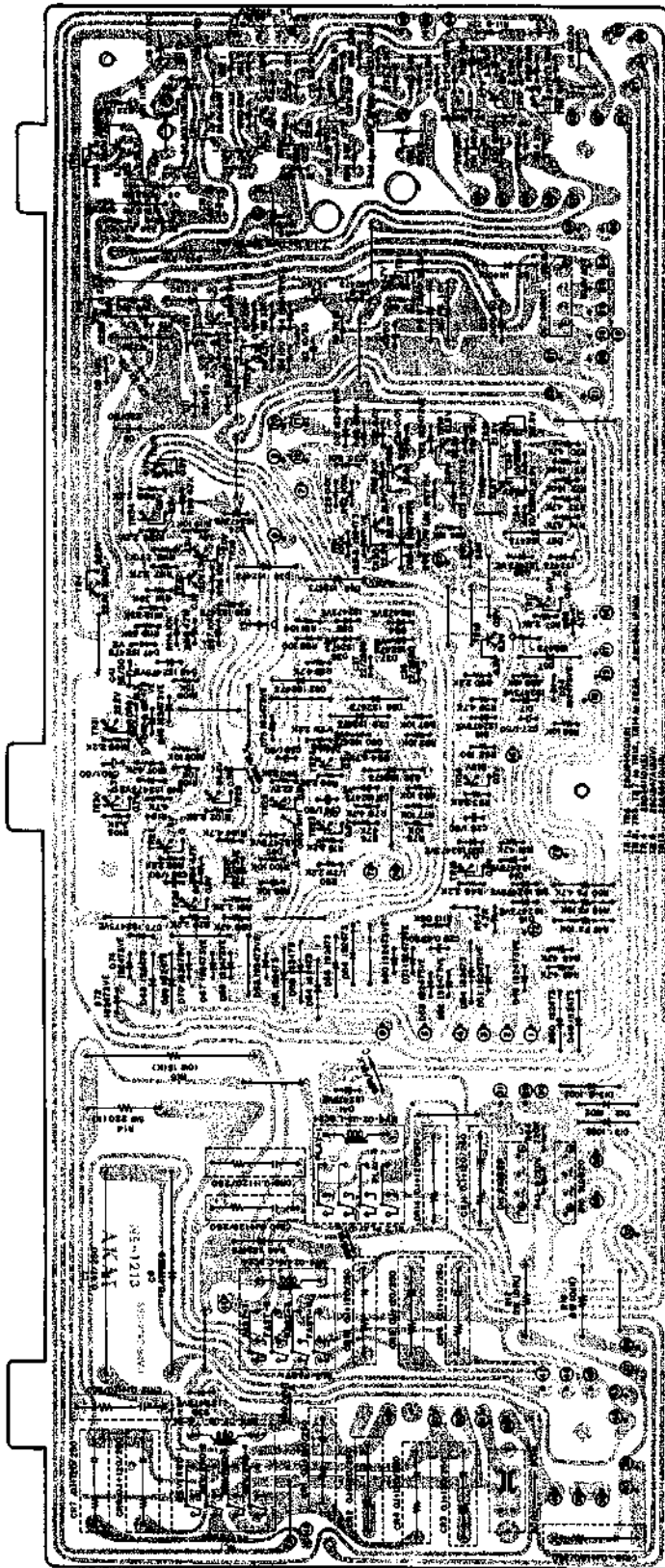

# IX . CLASSIFICATION OF VARIOUS P.C BOARDS

## 1. COMPOSITION OF VARIOUS P.C BOARDS

### 1) AMP P.C BOARD NE-5222

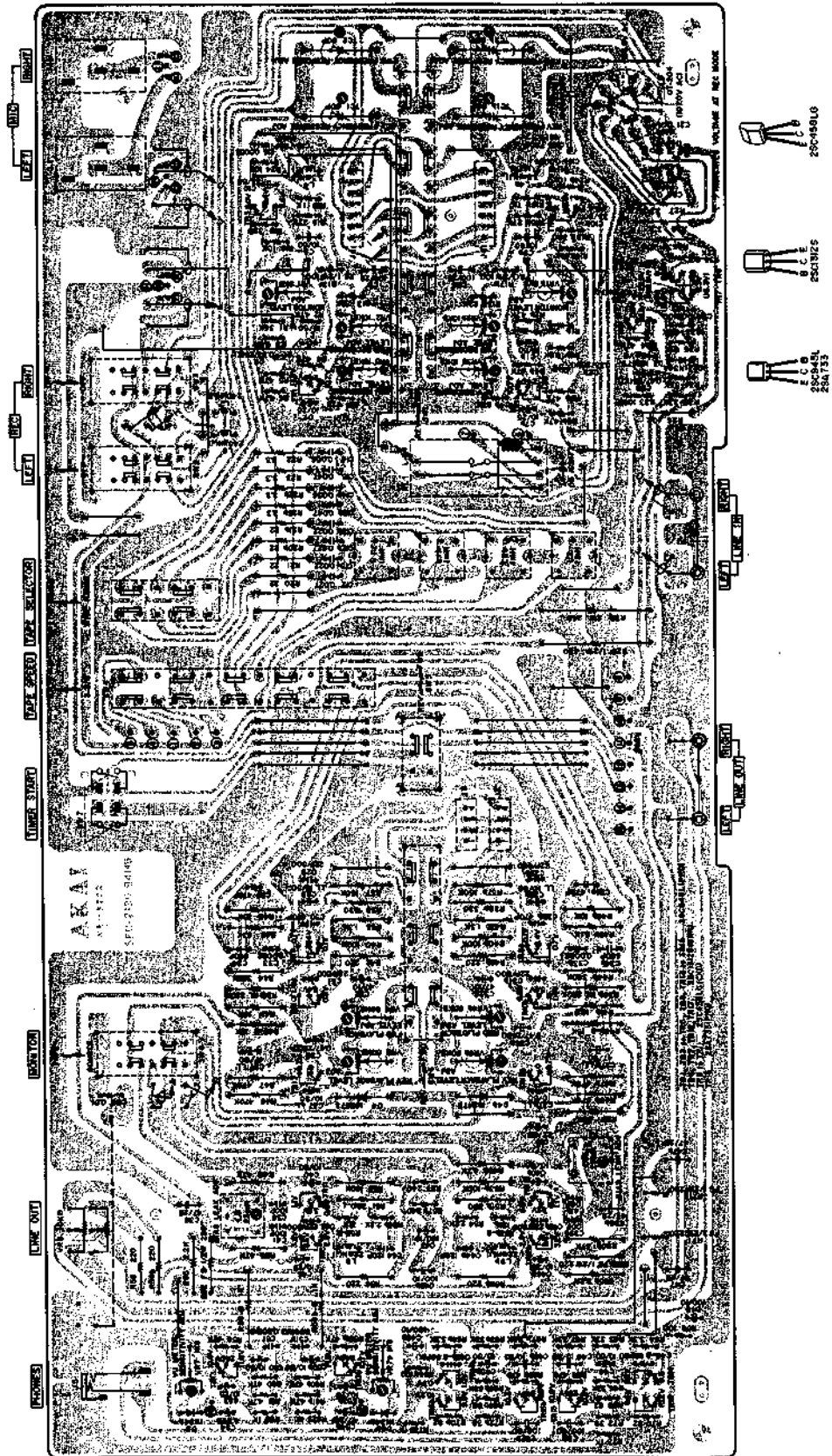



## HOW TO USE THIS PARTS LIST

1. This parts list is compiled by various individual blocks based on assembly process.
2. When ordering parts, please describe parts number, serial number, and model number in detail.
3. How to read list.

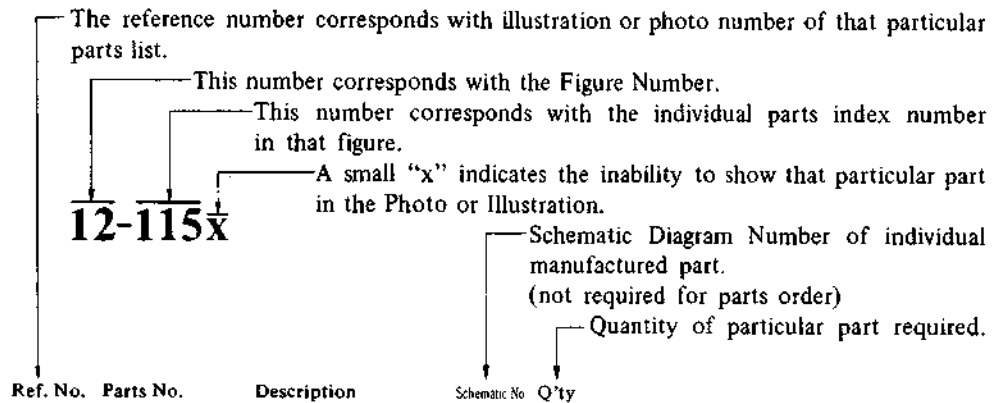

4. The symbol numbers shown on the P.C. Board list can be matched with the Composite Views of components of the Schematic Diagram or Service Manual.
5. The indications of Resistors and Capacitors in the photos of P.C. Board are being eliminated.
6. The shape of the parts and parts name, etc. can be confirmed by comparing them with the parts shown on the Electrical Parts Table of P.C. Board.
7. Both the kind of part and installation position can be determined by the Parts Number. To determine where a parts number is listed, utilize Parts Index at end of Parts List.  
It is necessary first of all to find the Parts Number. This can be accomplished by using the Reference Number listed at right of parts number in the Parts Index. (meaning of ref. no. outlined in Item 3 above).
8. Utilize separate "Price List for Parts" to determine unit price. The most simple method of finding parts Price is to utilize the reference number.

### CAUTION:

1. When placing an order for parts, be sure to list the parts no. model no., and description. There are instances in which if any of this information is omitted, parts cannot be shipped or the wrong parts will be delivered.
2. Please be careful not to make a mistake in the parts no. If the parts no. is in error, a part different from the one ordered may be delivered.
3. Because parts number and parts unit supply in the Preliminary Service Manual (Basic Parts List) may be partially changed, please use this parts list for all future reference.

**WARNING:**  $\Delta$  INDICATES SAFETY CRITICAL COMPONENTS. FOR CONTINUED SAFETY, REPLACE SAFETY CRITICAL COMPONENTS ONLY WITH MANUFACTURER'S RECOMMENDED PARTS.

**AVERTISSEMENT:**  $\Delta$  IL INDIQUE LES COMPOSANTS CRITIQUES DE SURETE. POUR MAINTENIR LE DEGRE DE SECURITE DE L'APPAREIL NE REMPLACER LES COMPOSANTS DONT LE FONCTIONNEMENT EST CRITIQUE POUR LA SECURITE QUE PAR DES PIECES RECOMMANDEES PAR LE FABRICANT.

# 1. ILLUSTRATION OF HEAD BLOCK

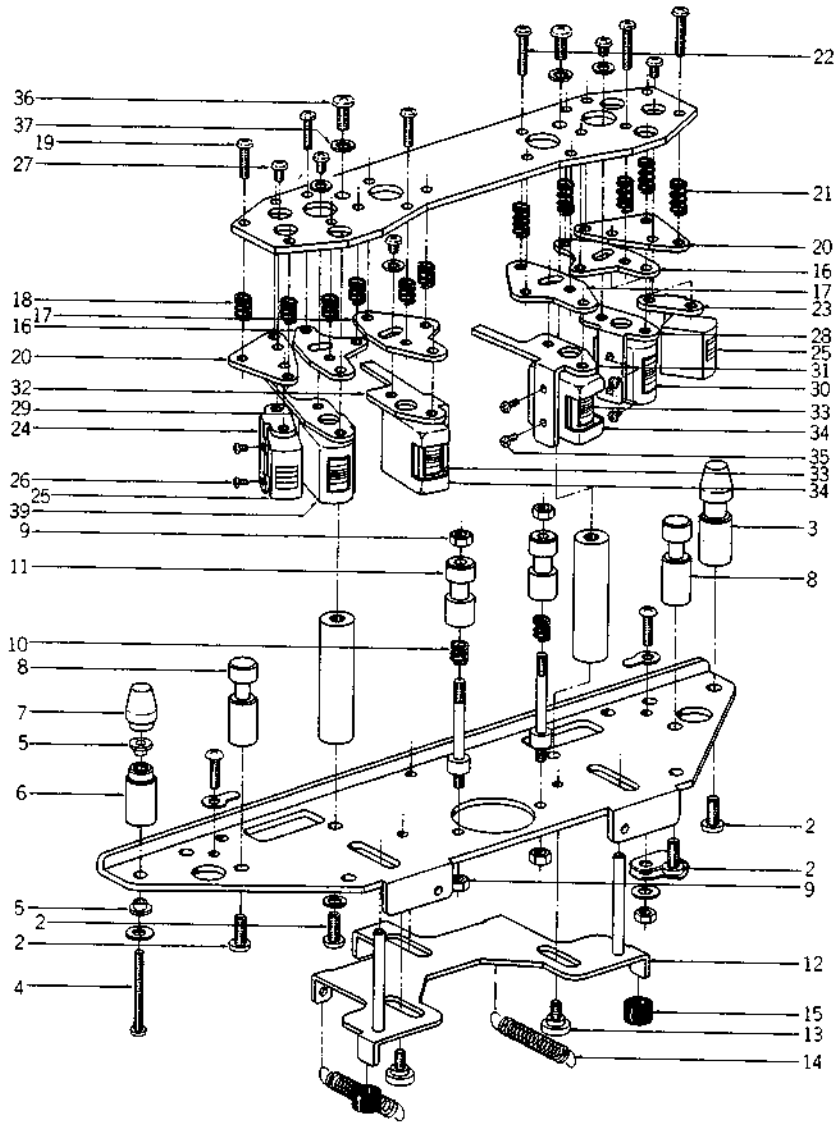

## 1) HEAD BLOCK

Ref. No.	Parts No.	Description	Schematic No.	Q'ty	Ref. No.	Parts No.	Description	Schematic No.	Q'ty
1-1x	BA300995	Head Block Comp.		1	1-23	HA301032	Erase Head Angle (A)	NE-0205	1
1-2	ZS413201	Screw, pan head 4x8		7	1-24	HA301033	Erase Head Angle (B)	NE-0205	1
1-3	MS643048	Tape Guide	NE-0002	1	1-25	HE563220	ERASE HEAD E4-260		2
1-4	ZS608264	Screw, pan head 3x25		1	1-26	ZS300626	Screw, pan head 2x2.5 (camera standard)		12
1-5	HZ527455	Sensing Spacer	ND-0011	2	1-27	ZS608477	Screw, pan head 3x4		4
1-6	MS643050	Sensing Guide A	NE-0003	1	1-28	HA301029	REC Head Angle (A)	NE-0203	1
1-7	MS643061	Sensing Guide B	NE-0004	1	1-29	HA301030	REC Head Angle (B)	NE-0203	1
1-8	HZ528581	Tape Guide A	ND-0006	2	1-30	HR271980	REC HEAD (R4-240) GX-215D(R)		2
1-9	ZW265522	M3 Nut, #2		4	1-31	HA301027	PB Head Angle (A)	NE-0202	1
1-10	ZG466312	Angle Adjust Spring E	BS-0018	2	1-32	HA301028	PB Head Angle (B)	NE-0202	1
1-11	HZ301777	Tape Guide (C)	NE-0212	2	1-33	HP271978	PB HEAD (P4-240) GX-215D(P)		2
1-12	ML301289	Shifter Slide Part GX-266D	NE-0208	1	1-34	HZ301366	Head Shield	NE-0211	2
1-13	ZS469710	MR Graduated Screw	MR-254	3	1-35	ZS201508	Screw, pan head 2x4		4
1-14	ZG527477	Shifter Spring	ND-0024	2	1-36	ZS201778	Screw, pan head 4x8		2
1-15	MB428343	Stopper Rubber, KD	KD-1088	2	1-37	ZW273914	Spring Washer		2
1-16	HB301025	Rec Head Base	NE-0201	2	1-38x	EJ303566	Micro Connector 4P Assy		2
1-17	HB301365	PB Head Base	NE-0213	2	1-39x	EJ303567	Micro Connector 7P Assy		2
1-18	ZG364656	Angle Adjust Spring C	RD-57	9	1-40x	ZS608321	Screw, pan head 3x6, w/washer		2
1-19	ZS417407	Screw, pan head 3x10		9					
1-20	HZ301031	Erase Head Base	NE-0204	2					
1-21	ZG466312	Angle Adjust Spring E	BS-0018	9					
1-22	ZS608512	Screw, pan head 3x13		9					

When ordering parts, please describe Parts Number, Description, and Model Number in detail.

## 2. ILLUSTRATION OF MAIN MOTOR BLOCK

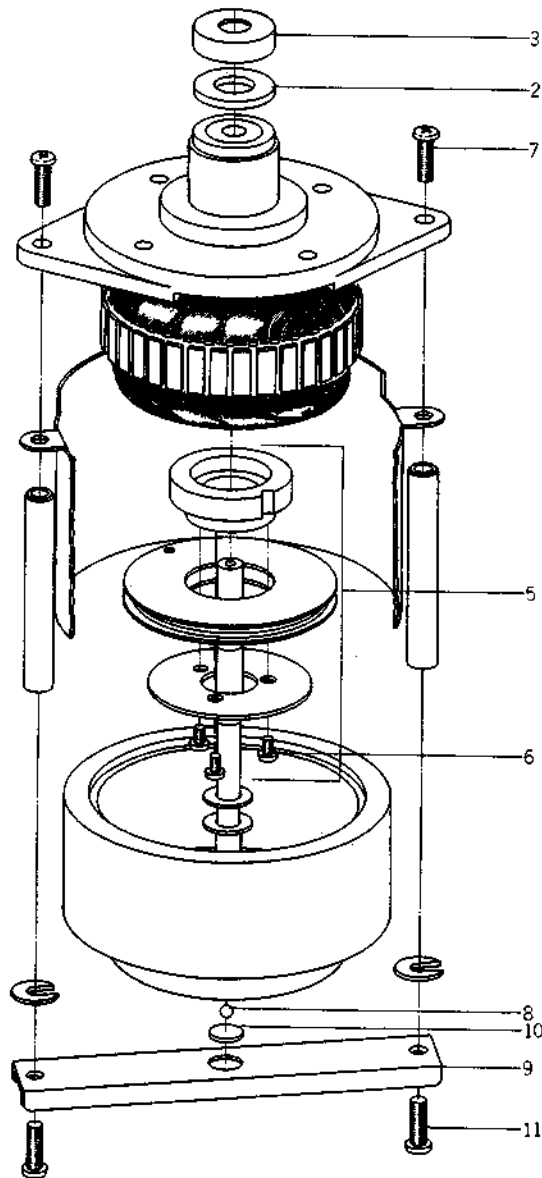

### 2) MAIN MOTOR BLOCK

Ref. No.	Parts No.	Description	Schematic No.	Qty
2-1x	BM636704	Main Motor (SCM2-24KJ) Block Comp.		1
2-2	ZW597622	Felt Washer	KJ-7022	1
2-3	SK597633	Cap	KJ-7023	1
2-4x	ZS608308	Screw, pan head 3x18, w/washer		3
2-5	BZ600300	Detector Gear Block Comp.		1
2-6	ZS477876	Screw, pan head 2x3		3
2-7	ZS424056	Screw, pan head 4x10		2
2-8	MV368886	Steel Ball D3		1
2-9	MZ597644	Thrust Angle	KJ-7024	1
2-10	MZ597690	Ball Holder	KJ-7029	1
2-11	ZS413201	Screw, pan head 4x8		2

When ordering parts, please describe Parts Number, Description, and Model Number in detail.

### 3. ILLUSTRATION OF REEL MOTOR/TABLE BLOCK

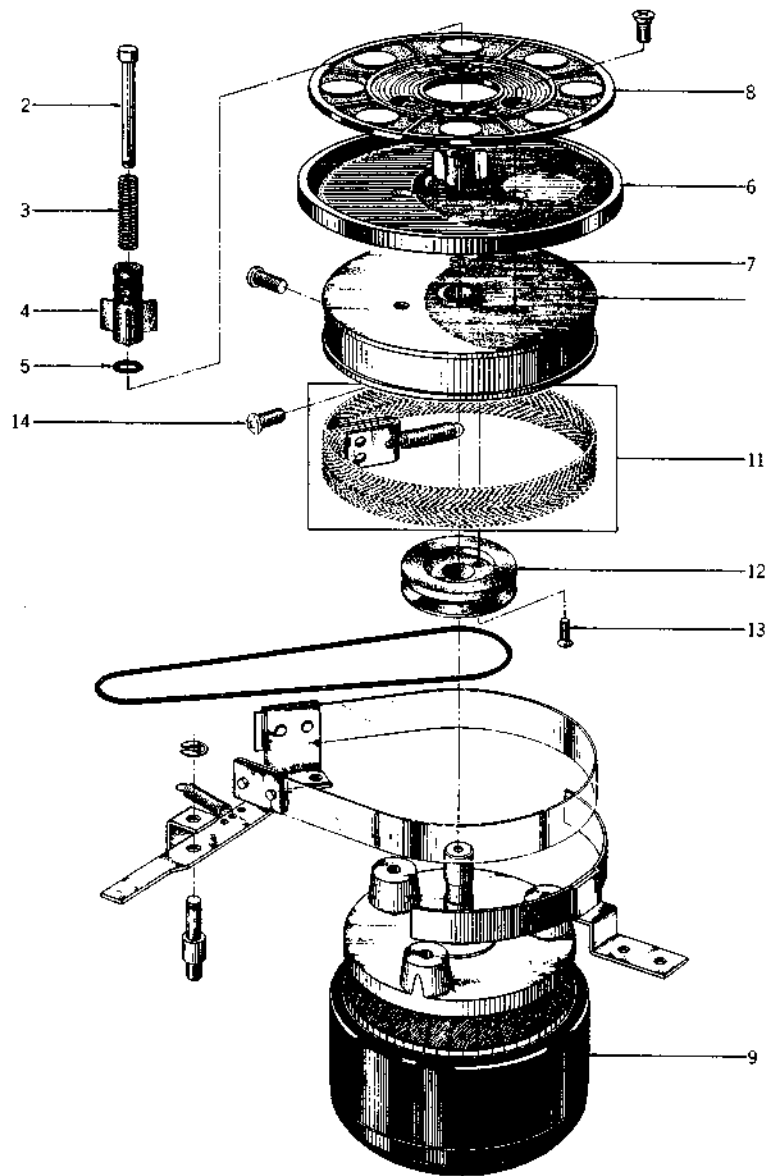

### 3) REEL MOTOR/TABLE BLOCK

Ref. No.	Parts No.	Description	Schematic No.	Q'ty	Ref. No.	Parts No.	Description	Schematic No.	Q'ty
3-1x	BR482400	Supply Reel Table Block Comp.		2	<b>BRAKE DRUM BLOCK</b>				
3-2	MS342000	Reel Shaft	3R-108	1	3-10x	ZS379350	Screw, pan head 3x6		1
3-3	ZG255633	Reel Spring	3R-109	1	3-11	MT436860	Brake Cloth Comp. MR	MR-269	1
3-4	MT255420	Reel Retainer	3R-102	1	3-12	MR317507	Counter Pulley (Take-up)	MR-217	1
3-5	MT516565	'O' Ring 2.8x1.9	3R-139	1	3-13	ZS433315	Screw, countersunk head 2.3x8		2
3-6	MT488147	Reel Table Disk B, RD	RD-272	1	3-14	ZS424056	Screw, pan head 4x10		2
3-7	ZW270088	'E' Ring 1.9M	6-1-9	1					
3-8	MT473422	Reel Table Rubber, KH	KH-2042	1					
3-9	BM314741	Motor Block Comp. 24X0-2 (Torque)		2					

#### 4. ILLUSTRATION OF OPERATION BLOCK

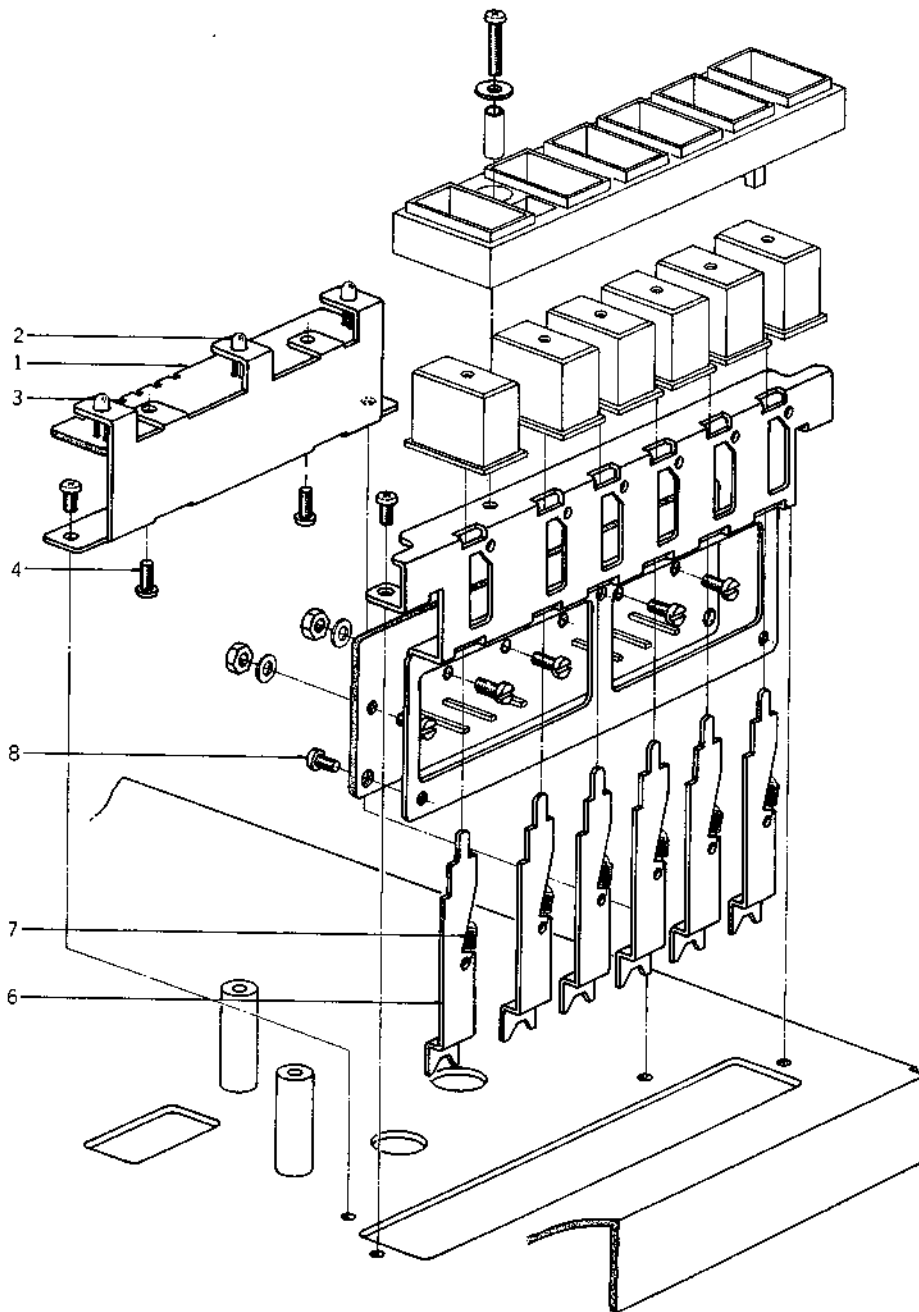

#### 4) OPERATION BLOCK

Ref. No.	Parts No.	Description	Schematic No.	Q'ty
<b>DIRECTION P.C BOARD BLOCK</b>				
4-1	EA301281	Lamp P.C Board	NE-2229	1
4-2	ED283138	LED GL-32PG	45-15-15	2
4-3	ED249377	LED GL-3AR1	45-15-14	1
4-4	ZS325495	Tapping Screw #2, 3x6(BR)		2
<b>OPERATION BLOCK</b>				
4-5	BK301003	Operation Block Comp.		1
4-6	ML301056	Operation Lever	NE-2214	6
4-7	ZG456120	Setting Lever Spring	CS-1187	6
4-8	ZS422076	Screw, pan head 3x5		3

When ordering parts, please describe Parts Number, Description, and Model Number in detail.

## 5. ILLUSTRATION OF TENSION BLOCK

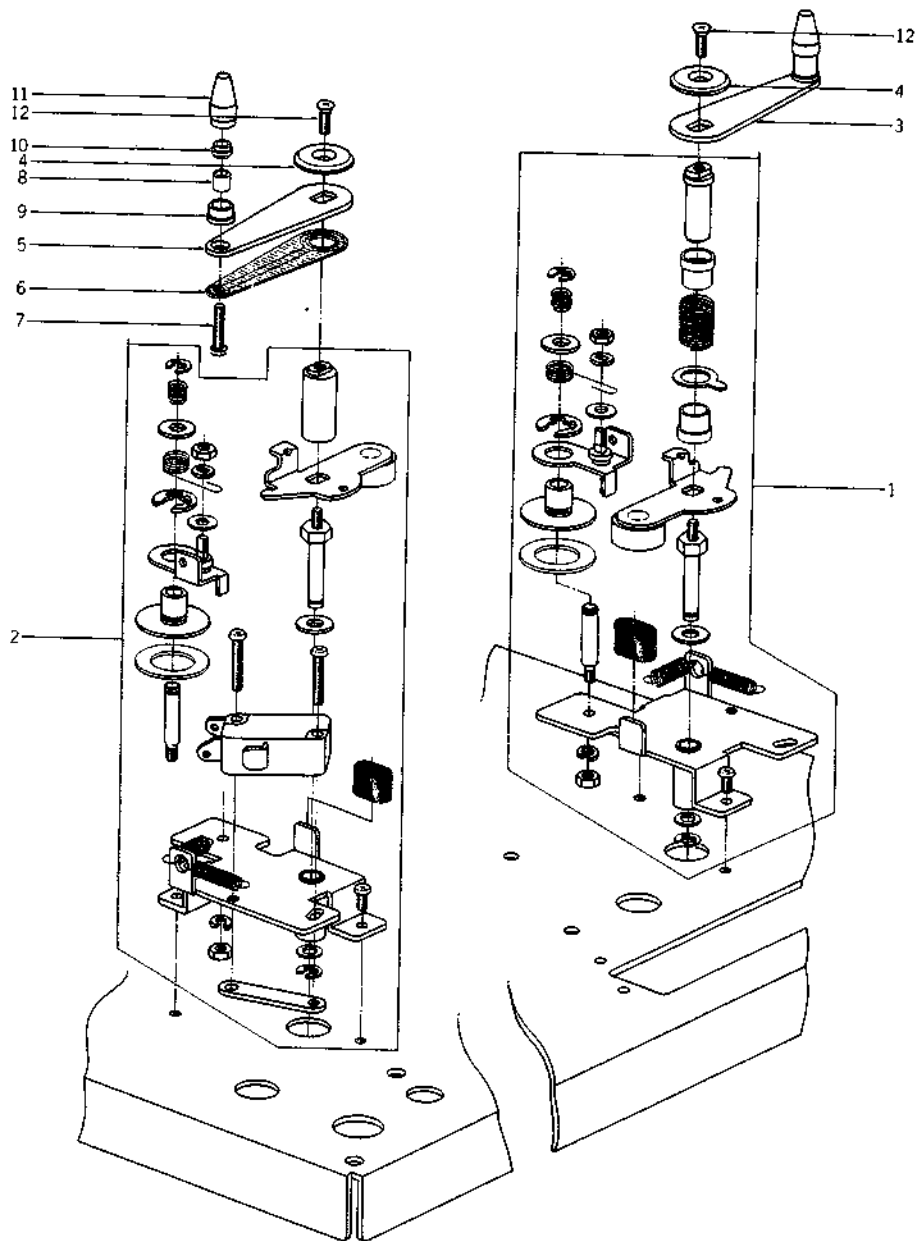

### 5) TENSION BLOCK

Ref. No.	Parts No.	Description	Schematic No.	Qty
5-1	BL301287	Tension (R) Block Comp.		1
5-2	BL301288	Tension (L) Block Comp.		1
<b>MECHA ASSEMBLY BLOCK</b>				
5-3	ML301270	Tension Arm Part NE-2	NE-2226	1
5-4	ZW302052	Decorative Washer	NE-1212	2
5-5	MZ301067	Tension Arm	NE-2226	1
5-6	EA301047	Tension Arm P.C Board	NE-2206	1
5-7	ZS419670	Screw, pan head 3x12		1
5-8	MZ535083	Insulator Bush B	TW-2076	1
5-9	HZ301037	Tape Guide (B)	NE-0210	1
5-10	MZ535072	Insulator Bush A	TW-2075	1
5-11	HZ301049	Tape Guide (A)	NE-2207	1
5-12	ZS203084	Screw, oval countersunk head 3x8		2

## 6. ILLUSTRATION OF PINCH ROLLER PLUNGER BLOCK

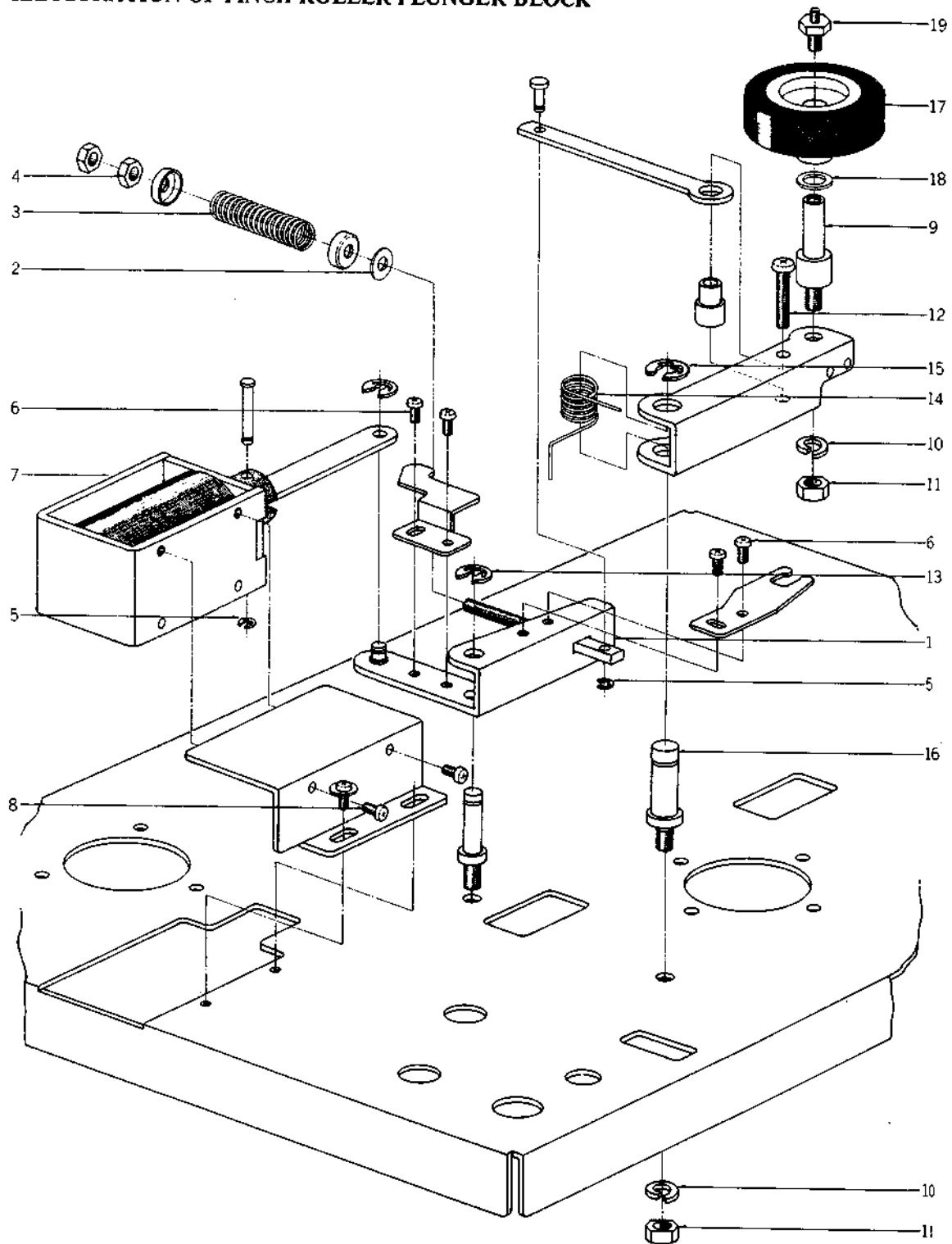

### 6) PINCH ROLLER PLUNGER BLOCK

Ref. No.	Parts No.	Description	Schematic No.	Q'ty	Ref. No.	Parts No.	Description	Schematic No.	Q'ty
6-1	ML301453	P Plunger Lever (B)			6-11	ZW413278	Nut M5, #1		2
		Part NE-2	NE-2027	1	6-12	ZS444262	Screw, binding head 4x8		1
6-2	ZW450753	Washer (Nylon) D4.1x9x1t		1	6-13	ZW290283	'U' Ring 2.85M	6-1-1	2
6-3	ZG644095	Cramp Spring	NE-2028	1	6-14	ZG301340	Pinch Roller Spring	NE-2237	1
6-4	ZW413188	Nut M4, #1		2	6-15	ZW270156	'E' Ring 6M	6-1-9	1
6-5	ZW270088	'E' Ring 1.9M	6-1-9	2	6-16	MS528456	Pinch Roller Arm Shaft	ND-100	1
6-6	ZS323728	Screw, binding head 3x5		6	6-17	MP275984	Pinch Roller RD D=40	RD-21	1
6-7	EP638706	Plunger Solenoid 1660PH	44-1-74	1	6-18	ZW376391	Washer (Rolyslider)		
6-8	ZS422076	Screw, pan head 3x5		2			D6.1x10x0.13t		2
6-9	MS527591	Pinch Roller Shaft	ND-1030	1	6-19	ZS527681	Pinch Roller Set Screw	ND-609	1
6-10	ZW274026	Spring Washer		2					

When ordering parts, please describe Parts Number, Description, and Model Number in detail.

## 7. ILLUSTRATION OF MECHA ASSEMBLY BLOCK

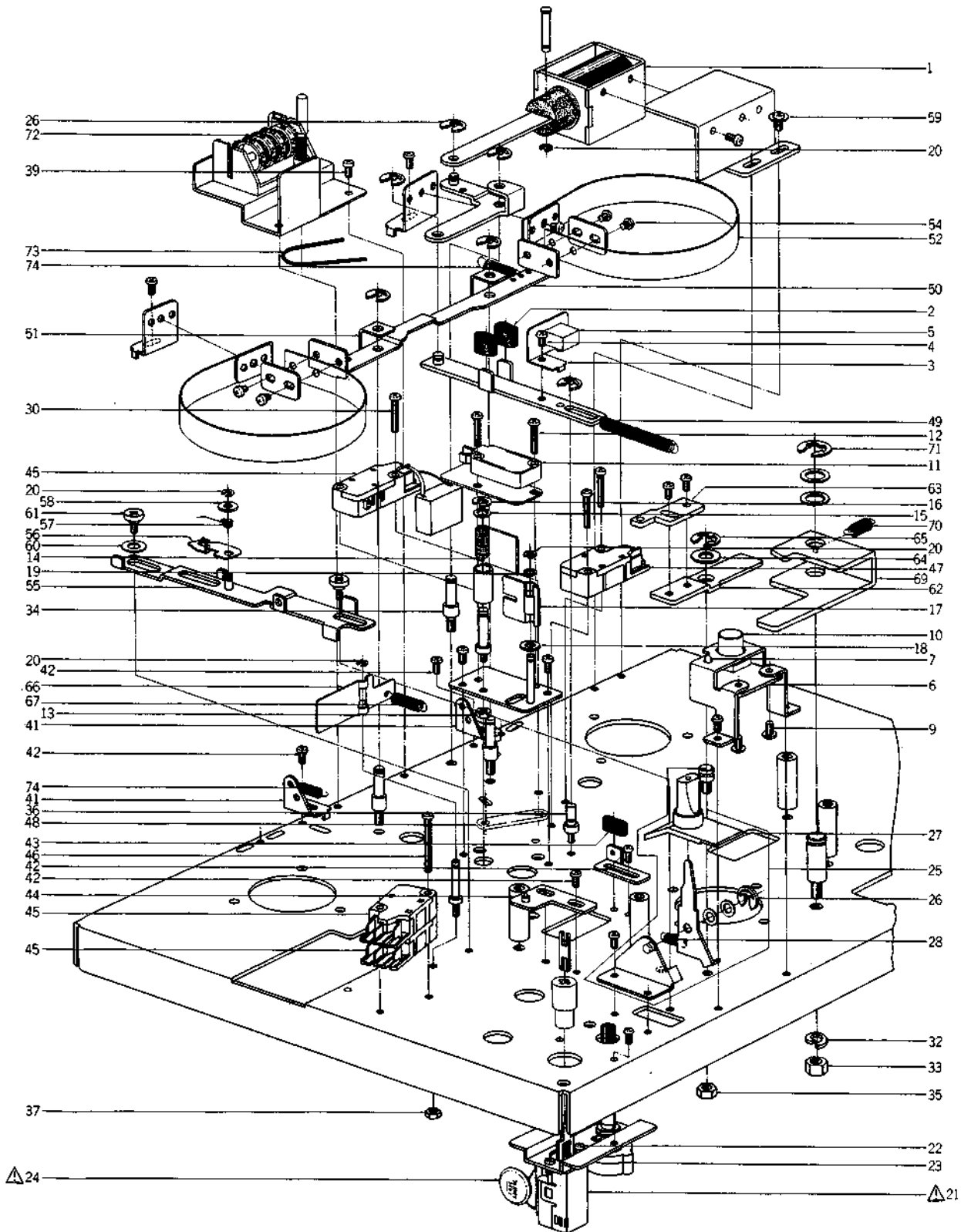

### 7) MECHA ASSEMBLY BLOCK

Ref. No.	Parts No.	Description	Schematic No.	Q'ty	Ref. No.	Parts No.	Description	Schematic No.	Q'ty
<b>BRAKE PLUNGER BLOCK</b>					<b>REC MUTE BLOCK</b>				
7-1	EP638695	Plunger Solenoid 1240PHT	44-1-73	1	7-6	EA301282	Mute SW, P.C Board	NE-2228	1
7-2	MB606712	Stopper Rubber KJ	KJ-2060	2	7-7	ED249377	LED GL-3AR1	45-15-14	1
7-3	MZ529244	SW. Plate	ND-1061	1	7-8x	ES301205	Tentacle SW. SCM81002	25-9-4	1
7-4	ZS417216	Screw, pan head 3x4		1	7-9	ZS325495	Tapping Screw #2, 3x6(BR)		11
7-5	MZ669532	Cushion, prevention shock	NE-1069	1	7-10	SB301065	Mute Button	NE-2222	1

When ordering parts, please describe Parts Number, Description, and Model Number in detail.



Ref. No.	Parts No.	Description	Schematic No.	Qty
<b>QUICK SW. BLOCK</b>				
7-11	ES422111	Micro SW. MT-10AT	25-1-21	1
7-12	ZS608512	Screw, pan head 3x13		2
7-13	ZW273756	Nut M3, #1		1
7-14	ZG529211	SW. Spring	ND-1053	1
7-15	ZW487811	Washer (Polyslider) D4.1x7x0.5t		1
7-16	ZW270101	'E' Ring 3M	6-1-9	1
7-17	MZ529391	Quick Plate	ND-1063	1
7-18	ZW550642	Washer (SPC) D3.1x7.9x0.5t		1
7-19	ZW438928	Washer (PBP) D3.5x5x0.2t		1
7-20	ZW270088	'E' Ring 1.9M	6-1-9	5
<b>POWER SW. BASE BLOCK</b>				
7-21	ES293703	△ Push SW. SDV1P TV-5	25-5-254	1
7-22	ZS422076	Screw, pan head 3x5		2
7-23	ES301207	Rotary SW. SRN1023SA1	25-6-110	1
7-24	EC335193	△ Ceramic/C. U/L 0.01μ 1.4k 150WV		1
<b>PAUSE SW. BLOCK</b>				
7-25	BS636805	Pause SW. Block Comp.	NE-1072	1
7-26	ZW290283	'U' Ring 2.85M	6-1-1	5
7-27	SK644117	Pause Knob	NE-2030	1
7-28	ZG567696	Azimuth Spring 2	CF-0041	1
<b>MECHA ASSEMBLY BLOCK</b>				
7-29x	ZS413201	Screw, pan head 4x8		14
7-30	ZS422965	Screw, pan head 3x15		5
7-31x	MH528107	Lever Pin	ND-1005	1
7-32	ZW274026	Spring Washr		2
7-33	ZW413278	Nut M3, #1		4
7-34	MS397012	Brake Lever Shaft	KD-1003	1
7-35	ZW413188	Nut M3, #1		4
7-36	MS465480	Brake Lever Shaft B	KD-1093	1
7-37	ZW273756	Nut M3, #1		2
7-38x	ML301219	Center Parts	NE-1209	1
7-39	ZS422076	Screw, pan head 3x5		29
7-40x	ZS447840	Tapping Screw #2, 3x8 (BR)		6
7-41	MZ247825	Spring Hanger	MU-1306	2
7-42	ZS323728	Screw, binding head 3x5		10
7-43	MZ810191	Cushion Rubber, RD	RD-278	1
7-44	MZ673165	Pause Lock Base Part NE	NE-1010	1
7-45	ES573456	Micro SW. K-2	25-1-30	3
7-46	ZS608264	Screw, pan head 3x25		2
7-47	ES562465	Micro SW. K-1	25-1-26	1
7-48	ZW397146	Micro SW. Nut	KD-1057	1
7-49	ZG527938	FF Reset Spring	ND-1024	1
7-50	ML314976	Brake Lever A	MR-210	1
7-51	ML396810	Brake Lever B	KD-1038	2
7-52	MT314987	Brake Band	MR-213	2
7-53x	ZS432674	Screw, pan head 3x3		6
7-54	ZS417216	Screw, pan head 3x4		4
7-55	ML301274	Pause Arm (3) Part NE-2	NE-1204	1
7-56	TC515575	SW. Lock Cam B	CG-2301	1
7-57	ZG514440	Button Lock Spring B	CG-2303	1
7-58	ZW616004	Washer (SPC) D3.2x8x1t		1
7-59	ZS608321	Screw, pan head 3x6 w/washer		2
7-60	ZW374545	Washer (PBP) D5.1x10.3x0.4t		1
7-61	ZS469710	MR Grduated Screw	MR-254	2
7-62	ML301038	Pause Arm (1)	NE-1202	1
7-63	ML301039	Pause Arm (2)	NE-1203	1
7-64	ZW260188	Washer (Nylon) D6.2x13x0.5t		1
7-65	ZW270134	'E' Ring 5M	6-1-9	1
7-66	MZ640080	Quick Plate	NE-1039	1
7-67	ZG232121	Tension Lever Spring	MH-143	1
7-68x	ZS608310	Screw, pan head 3x5, w/lug		1
7-69	ML301103	Pause Arm (B-2)	NE-1012	1
7-70	ZG516418	Eject Spring	CG-1238	1
7-71	ZW334653	'E' Ring 7M	6-1-9	1
7-72	MC638684	Counter MP490-23	9-1-43	1
7-73	MB527556	Counter Belt D93x1.5	ND-1022	1
7-74	ZG315011	Brake Lever Spring	MR-116	2

## 8. P.C BOARDS

### (1) AMP P.C BOARD (NE-5222) BLOCK

Symbol No.	Parts No.	Description	Schematic No.	Qty
(1)-1	BA301275	Amp P.C Board Comp.		1
		GX-266D		
(1)-TR1	ET639437	Transistor 2SC945L(Q)(P)	45-1-85	2
(1)-TR3	ET539437	Transistor 2SC945L(Q)(P)	45-1-85	4
		to 5		
(1)-TR6,7	ET603257	Transistor 2SC1312S(G)(H)	45-1-182	2
(1)-TR8	ET639437	Transistor 2SC945L(Q)(P)	45-1-85	1
(1)-TR9	ET391768	Transistor 2SC458LG(C)(D)	45-1-29	6
		to 11		
(1)-TR12	ET603257	Transistor 2SC1312S(G)(H)	45-1-182	2
(1)-TR13	ET639437	Transistor 2SC945L(Q)(P)	45-1-85	6
		to 15		
(1)-TR16	ET554657	Transistor 2SA733(P)(Q)	45-1-124	2
(1)-TR17	ET603257	Transistor 2SC1312S(G)(H)	45-1-182	2
(1)-D1	ED624903	Silicon Diode 1S2473	45-3-28	1
(1)-D2	ED219464	Germanium Diode 1N34A	45-3-1	1
(1)-D3	ED560913	Silicon Diode 1S2473VE	45-3-23	1
(1)-D4	ED624903	Silicon Diode 1S2473	45-3-28	2
(1)-D5	ED219464	Germanium Diode 1N34A	45-3-1	2
(1)-D6	ED624903	Silicon Diode 1S2473	45-3-28	1
(1)-RL1	EP249344	Reed Relay, L Type L24	47-2-28	1
(1)-L1,2	E0301448	Inductor 45H-044 1MH	23-1-277	4
(1)-L4	E0301467	Ferri Inductor RX-9P 3.3MH(J)	23-1-275	2
(1)-L5	ED383365	OSC. Coil 0T-204	23-4-20	1
(1)-L6,7	E0565558	Ferri Inductor FL9H 240μH(J)	23-1-213	2
(1)-L8	E0624857	Inductor GE6070A 23MH	23-1-227	2
(1)-L9	E0301712	Coil RX-9P 22MH(J)	23-1-275	2
(1)-J1	EJ249221	Mic. Jack MU	31-2-77	2
(1)-J2A-B	EJ301714	Jack Plate NE-2	31-5-138	1
(1)-J3	EJ249333	Micro Connector 4P Plug MU	42-1-104	2
(1)-J4	EJ249366	Micro Connector 7P Plug MU	42-1-104	2
(1)-J5	EJ249232	Headphone Jack MU	31-2-77	1
(1)-VR1	EV464207	Semi-fixed/Vol. V8K4-1 5 kB	36-10-266	2
(1)-VR2,	EV520806	Semi-fixed/Vol. V8K4-1 10 kB	36-10-266	4
(1)-VR4,	EV464220	Semi-fixed/Vol. V8K4-1 50 kB	36-10-266	4
(1)-VR6	EV301437	Single axial 2 throw Vol. GM70R-715 10 kBx2	36-22-28	1
(1)-VR7	EV478686	Semi-fixed/Vol. V8K4-1 1 kB	36-10-266	2
(1)-SW1	ES301435	Slide SW. SL-210E	25-3-136	1
(1)-SW2,3	ES301433	Lever SW. SLR542	25-12-39	2
(1)-SW4	ES301434	Push SW. SUE-24	25-5-256	1
(1)-SW5	ES301715	Slide SW. SSB02214	25-3-127	1
(1)-SW6	ES301436	Slide SW. CL-206E	25-3-135	1
(1)-SW7	ES301438	Leaf SW. BSW-89	25-10-27	1
(1)-SW8	ES301433	Lever SW. SLR542	25-12-39	1
(1)-2	ZS558101	Screw, pan head 3x6 w/washer		2
(1)-TC1,2	EC558202	Trimmer/C. TM-80A	24-2-26	4
(1)-C2	EC604102	Solid Aluminum/C. (Vert. Type) 0.33μF(K) 25WV	24-19-2	2
(1)-C10	EC303145	Tantalum/C. (DTS Type) 22μF(K) 16WV	24-15-8	2
(1)-C18	EC562678	Styrol/C. (Vert. Type) 750PF(J) 50WV	24-11-3	2
(1)-C22	EC558235	Styrol/C. (Tub. Type) 1800PF(J) 250WV	24-11-10	1
(1)-C23	EC675178	Solid Aluminum/C. (Vert. Type) 0.47μF(K) 25WV	24-19-2	1
(1)-C25	EC301445	Solid Aluminum/C. (Vert. Type) 4.7μF(K) 16WV	24-19-2	1
(1)-C26	EC303145	Tantalum/C. (DTS Type) 22μF(K) 16WV	24-15-8	1
(1)-C30	EC405898	Styrol/C. (Vert. Type) 470PF(J) 50WV	24-11-3	2
(1)-C34	EC434070	Styrol/C. (Vert. Type) 680PF(J) 50WV	24-11-3	2

When ordering parts, please describe Parts Number, Description and Model Number in detail.

Symbol No.	Parts No.	Description	Schematic No.	Qty
(1)-C35	EC405898	Styrol/C. (Vert. Type) 470PF(J) 50WV	24-11-3	2
(1)-C36	EC675178	Solid Aluminium/C. (Vert. Type) 0.47µF(K) 25WV	24-19-2	2
(1)-C39	EC513944	Styrol/C. (Vert. Type) 100PF(J) 50WV	24-11-3	2
(1)-C41	EC513944	Styrol/C. (Vert. Type) 100PF(J) 50WV	24-11-3	2
(1)-C56	EC379721	Mylar/C. (Vert. Type) 0.0012µF(J) 50WV	24-1-1	2
(1)-C57	EC391004	Mylar/C. (Vert. Type) 0.0033µF(J) 50WV	24-1-1	2
(1)-R32	ER303148	Metal Oxide Film/R. 2W 240 ohms(J)	35-15-18	1
(1)-R71	ER666854	Carbon/R. F1/2W 220 ohms (J)	35-11-13	1

## (2) SYS. CON P.C BOARD (NE-1313) BLOCK

(2)-1	BA301455	Sys. Con P.C Board Comp. GX-266D		1
(2)-TR1	ET301249	Transistor 2SC1846(Q)(R)	45-1-267	1
(2)-TR2,	ET639437	Transistor 2SC945L(Q)(P)	45-1-85	2
(2)-TR4	ET537300	Transistor 2SD361(D)(E)	45-1-143	1
(2)-TR5	ET511920	Transistor 2SC1247A(B)(V)	45-1-131	1
(2)-TR6	ET301249	Transistor 2SC1846(Q)(R)	45-1-267	1
(2)-TR7	ET639437	Transistor 2SC945L(Q)(P)	45-1-85	4
(2)-TR11,	ET399846	Transistor 2SC945L(Q)	45-1-85	2
(2)-TR13	ET538154	Transistor 2SA564(Q)(R)	45-1-44	1
(2)-TR14	ET399846	Transistor 2SC945L(Q)	45-1-85	1
(2)-TR15	ET639437	Transistor 2SC945L(Q)(P)	45-1-85	4
(2)-TR19,	ET398711	Transistor 2SC945L(Q)(R)	45-1-85	1
(2)-TR21	ET639437	Transistor 2SC945L(Q)(P)	45-1-85	15
(2)-D1	ED249581	Silicon Diode SIQB20 0.6A 200V (RED)	45-2-74	1
(2)-D2	ED511097	Silicon Diode 1N4001	45-2-50	1
(2)-D3	ED511918	Zener Diode WZ-240	45-6-67	1
(2)-D3B	ED624903	Silicon Diode 1S2473	45-3-28	1
(2)-D4/B	ED560913	Silicon Diode 1S2473VE	45-3-23	2
(2)-D4C	ED624903	Silicon Diode 1S2473	45-3-28	1
(2)-D5	ED539976	Zener Diode WZ-130	45-6-67	1
(2)-D6	ED249581	Silicon Diode SIQB20 0.6A 200V (RED)	45-2-74	1
(2)-D7	ED303123	Zener Diode 05Z24U	45-6-67	1
(2)-D8	ED357794	Zener Diode RD-5A(M)	45-6-71	1
(2)-D9	ED557447	Silicon Diode 1S1588	45-3-22	1
(2)-D10,	ED249581	Silicon Diode SIQB20 0.6A 200V (RED)	45-2-74	2
(2)-D12,	ED224548	Silicon Diode 10D2	45-2-14	3
(2)-D14	ED560913	Silicon Diode 1S2473VE	45-3-23	5
(2)-D19	ED624903	Silicon Diode 1S2473	45-3-28	1
(2)-D20	ED560913	Silicon Diode 1S2473VE	45-3-23	5
(2)-D21B,	ED624903	Silicon Diode 1S2473	45-3-28	2
(2)-D23B	ED560913	Silicon Diode 1S2473VE	45-3-23	1
(2)-D25B	ED624903	Silicon Diode 1S2473	45-3-28	1
(2)-D26/BED	ED624903	Silicon Diode 1S2473	45-3-28	2
(2)-D27	ED562397	Germanium Diode 1S188FM-1	45-3-25	1
(2)-D28	ED560913	Silicon Diode 1S2473VE	45-3-23	1
(2)-D29	ED624903	Silicon Diode 1S2473	45-3-28	1
(2)-D30,	ED560913	Silicon Diode 1S2473VE	45-3-23	2
(2)-D32	ED624903	Silicon Diode 1S2473	45-3-28	1
(2)-D33,	ED560913	Silicon Diode 1S2473VE	45-3-23	2
(2)-D35	ED624903	Silicon Diode 1S2473	45-3-28	1
(2)-D36	ED560913	Silicon Diode 1S2473VE	45-3-23	3
(2)-D39	ED624903	Silicon Diode 1S2473	45-3-28	1

Symbol No.	Parts No.	Description	Schematic No.	Qty
(2)-D40	ED560913	Silicon Diode 1S2473VE	45-3-23	3
(2)-D42B,	ED560913	Silicon Diode 1S2473VE	45-3-23	2
(2)-D44	ED624903	Silicon Diode 1S2473	45-3-28	1
(2)-D45	ED560913	Silicon Diode 1S2473VE	45-3-23	4
(2)-D49,	ED624903	Silicon Diode 1S2473	45-3-28	2
(2)-D51	ED560913	Silicon Diode 1S2473VE	45-3-23	4
(2)-D55	ED624903	Silicon Diode 1S2473	45-3-28	5
(2)-D60	ED560913	Silicon Diode 1S2473VE	45-3-23	1
(2)-D61,	ED624903	Silicon Diode 1S2473	45-3-28	2
(2)-D63	ED560913	Silicon Diode 1S2473VE	45-3-23	1
(2)-D64	ED624903	Silicon Diode 1S2473	45-3-28	1
(2)-D65	ED560913	Silicon Diode 1S2473VE	45-3-23	3
(2)-D68,	ED624903	Silicon Diode 1S2473	45-3-28	2
(2)-D70	ED560913	Silicon Diode 1S2473VE	45-3-23	6
(2)-RL1	EP300132	Relay MY4-02-US-L	47-1-32	3
(2)-SW1	ES258232	Slide SW. S-2930	25-3-129	1
(2)-TH1	ED593357	Thermister 34D21	45-5-21	1
(2)-VR1	EV478686	Semi-fixed/Vol. V8K4-1 1 kB	36-10-266	1
(2)-VR2	EV302718	Semi-fixed/Vol. V18K3-6(4US) 50 kB	36-9-26	1
(2)-VR3	EV302719	Semi-fixed/Vol. V18K3-6(4US) 10 kB	36-9-26	1
(2)-CR1	ER226798	Spark Quencher 0.1µ+120 ohms 250WV	41-1-10	15
(2)-2	ZS379350	Screw, pan head 3x6		3
(2)-3	ZW516993	Nut M3, #1		1
(2)-4	ZS666336	Tapping Screw #2, 3x8(pan)		1
(2)-C6,7	EC462611	MP/C. (Tub. Type) 0.47µF(K) 250WV	24-9-28	2
(2)-C12	EC565345	Elect./C. (Vert. Type) 1000µF 50WV	24-12-9	1
(2)-C33,	EC301424	Tantalum/C. 10µF(M) 25WV	24-15-10	2
(2)-C35	EC237925	Tantalum/C. 22µF(M) 25WV	24-15-11	1
(2)-C37	EC237936	Tantalum/C. (DTS Type) 22µF(M) 25WV	24-15-8	1
(2)-R3	ER391634	Metal Oxide Film/R. 1W 1K(K)	35-15-10	1
(2)-R14	ER303122	Cement/R. 10W 220 ohms (K)	35-16-72	1
(2)-R15	ER301248	Cement/R. 10W 15 ohms (K)	35-16-72	1
(2)-R16,	ER301248	Cement/R. 5W 10 ohms (K)	35-16-71	2
(2)-R43	ER622045	Cement/R. (Metal ox. Film/T) 2W 330 ohms(K)	35-16-11	1

## (3) MIC AMP P.C BOARD (NE-5223) BLOCK

Symbol No.	Parts No.	Description	Schematic No.	Qty
(3)-1	BA301276	Mic Amp P.C Board Comp. GX-266D		1
(3)-TR1	ET391768	Transistor 2SC458LG(C)(D)	45-1-29	6
(3)-TR4	ET603257	Transistor 2SC1312S(G)(H)	45-1-182	2
(3)-VR1	EV301428	Double axial 2 throw Vol. DM20R608 50 kAx2	36-18-4	1
(3)-C4	FC301430	Styrol/C. (w/rubber) 220PF(K) 50WV	24-11-12	2
(3)-C6	EC301432	Solid Aluminium/C. (Vert. Type) 2.2µF(K) 16V	24-19-2	2
(3)-C7	EC487394	VFM/C. 47PF(K) 50WV	24-6-2	2

When ordering parts, please describe Parts Number, Description and Model Number in detail.

## 9. ILLUSTRATION OF POWER SUPPLY BLOCK

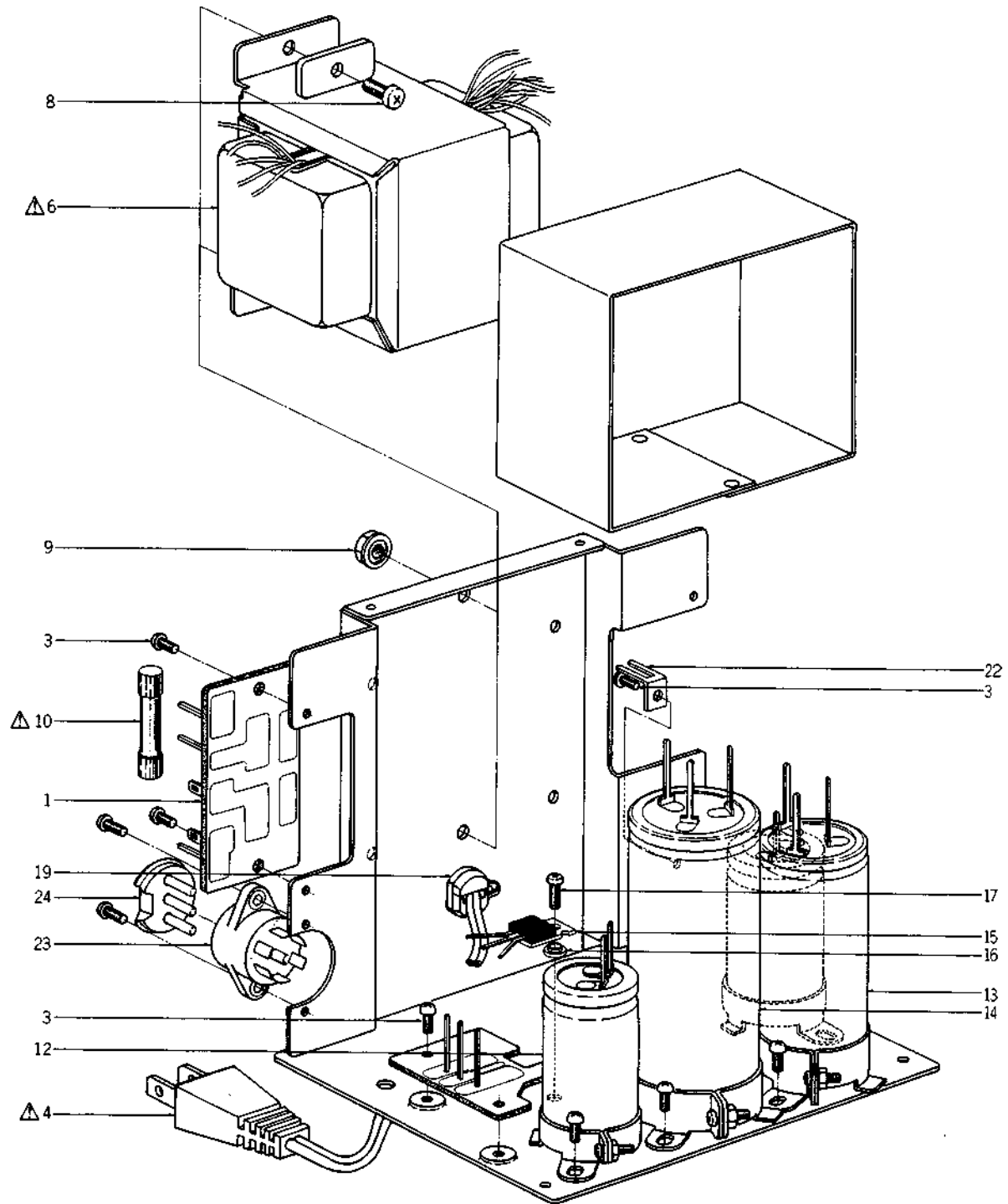

### 9) POWER SUPPLY BLOCK

Ref. No.	Parts No.	Description	Schematic No.	Q'ty	Ref. No.	Parts No.	Description	Schematic No.	Q'ty
<b>FUSE P.C BOARD BLOCK</b>									
9-1	BA301326	Fuse P.C Board Comp. GX-266D (U/T)	NE-2235	1	9-11x	EF563703	△ Fuse 2A 250V	39-1-9	1
9-2x	BA301336	Fuse P.C Board Comp. GX-266D (JPN)	NE-2231	1	9-12	EC301412	Elect. /C. 220μF 160WV	24-10-120	2
9-3	ZS325495	Tapping Screw #2, 3x6 (BR)		14	9-13	EC301251	MP/C. (Wrapping Type) 3.5+1.5μF 150WV	24-9-21	1
<b>POWER SUPPLY BLOCK</b>									
9-4	EW374894	△ AC Cord CUL 3M	26-3-19	1	9-14	EC249592	MP/C. 4+4μF 250WV	24-9-16	1
9-5x	EW524845	△ AC Cord (J) 2.5M	26-3-31	1	9-15	ET621775	Transistor TIP-47	45-1-116	1
9-6	BT300984	△ Power Trans. NET-2	38-4-502	1	9-16	EZ209215	Insulator Bush B308D	45-16-1	1
9-7x	BT301295	△ Power Trans. NET-1	38-4-503	1	9-17	ZS421806	Screw, pan head 3x8		1
9-8	ZS424056	Screw, pan head 4x10		2	9-18x	ZW516993	Nut M3, #1		1
9-9	ZW413267	Flange Nut M4		2	9-19	EZ631945	Strain Relief SR-4N-4	2-7-49	1
9-10	EF638807	△ Fuse 1A 250V	39-1-65	1	9-20x	EJ301250	4P Fuse Holder (Large B) (Wrapping Type) (JPN)	40-1-113	1
					9-21x	ZS447840	Tapping Screw #2, 3x8 (BR)		2
					9-22	EJ539447	Earth Terminal 2P T4460	32-1-3	1
					9-23	EJ262732	Socket (Volt. Selector)	31-1-180	1
					9-24	EJ249467	Voltage Selector MU	42-1-109	1
					9-25x	EZ260381	Mylar Sheet P103KA	45-16-1	1

When ordering parts, please describe Parts Number, Description and Model Number in detail.

# 10. ILLUSTRATION OF AMP ASSEMBLY BLOCK

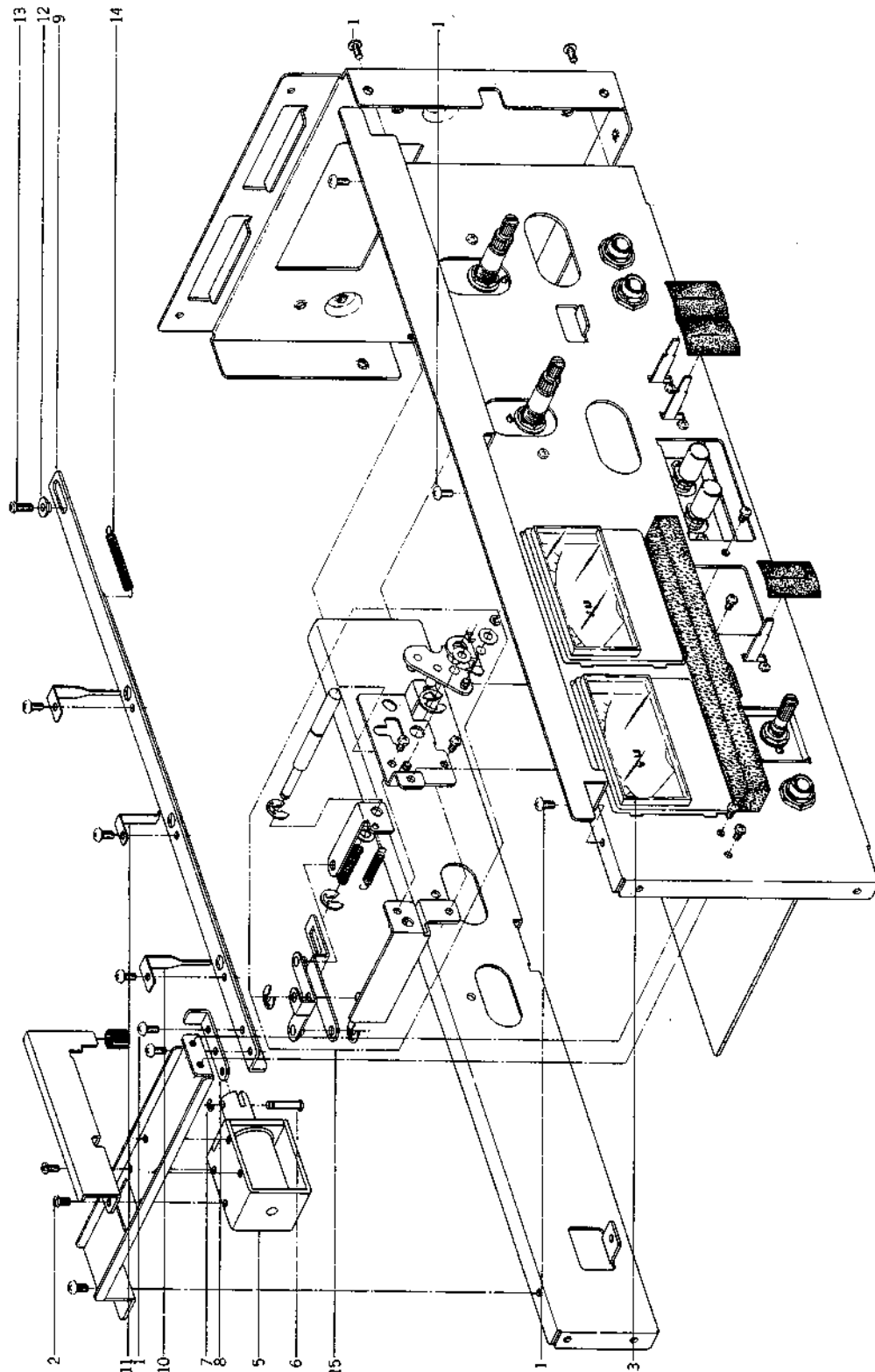

## 10) AMP ASSEMBLY BLOCK

Ref. No.	Parts No.	Description	Schematic No.	Q'ty	Ref. No.	Parts No.	Description	Schematic No.	Q'ty
10-1	ZS325495	Tapping Screw #2, 3x6 (BR)		19	10-9	ML301123	Reverse Arm	NE-5218	1
10-2	ZS422076	Screw, pan head 3x5		14	10-10	ZG301072	Reverse SW. Spring (A)	NE-5206	2
10-3	EM301277	VU Meter KL-250S-9	46-1-167	2	10-11	ZG301073	Reverse SW. Spring (B)	NE-5207	1
10-4x	ZW260370	Nylon Rivet 3.4x5.5	2-7-56	2	10-12	ZW625241	Graduated Washer	MY-1013	1
10-5	EP638695	Plunger Solenoid 1240PHT	44-1-73	1	10-13	ZS447840	Tapping Screw #2, 3x8 (BR)		1
10-6	MH257477	Connecting pin	RD-211	1	10-14	ZG301089	Reverse Arm Spring	NE-5226	1
10-7	ZW270088	'E' Ring 1.9M	6-1-9	1	10-15	BZ301009	Timer Block Comp. GX-266D		1
10-8	MZ301084	Reverse Joint	NE-5219	1	10-16x	ZS558101	Screw, pan head 3x6 w/washer		2

When ordering parts, please describe Parts Number, Description and Model Number in detail.

## 11. PHOTO OF FINAL ASSEMBLY BLOCK



### 11) FINAL ASSEMBLY BLOCK

Ref. No.	Parts No.	Description	Schematic No.	Q'ty	Ref. No.	Parts No.	Description	Schematic No.	Q'ty
<b>MECHA PANEL BLOCK</b>									
11-1	BD301257	Mecha Panel Block Comp. GX-266D		1	11-19	SP301231	Upper Cover	NE-6201	1
11-2	SE626951	Counter Escutcheon	MY-6006	1	11-20	SP301255	Side Cover	NE-6203	2
11-3	SZ301096	Decorative Ring	NE-6219	2	11-21	BZ301755	Button Escutcheon Assy NE-2		1
11-4	SE301134	Reel Table Escutcheon (2-B)	TD-6021	2	11-22x	ZS483502	Screw, pan head 3x13		1
11-5	SC301213	Head Cover Base	NE-6217	1	11-23	ZS613901	Panel Screw	CW-6031	8
11-6x	ZS462194	Tapping Screw #2, 3x8 (PAN) w/washer		2	11-24	SK301098	Double Knob (Lower)	NE-6221	2
<b>AMP PANEL BLOCK</b>									
11-7	SP301224	Amp Panel	NE-6212	1	11-25	SK301097	Double Knob (Upper)	NE-6220	2
11-8x	SZ301100	Ring Felt	NE-6228	2	11-26	SK301092	Lever Knob (A)	NE-6214	2
11-9	SZ301090	Memory Ring	NE-6204	2	11-27	SK301093	Lever Knob (B)	NE-6214	1
11-10x	SZ301132	Ring Retainer	NE-6223	2	11-28	SK301083	Timer Knob	NE-5217	1
11-11	SE301115	Meter Cover	NE-6206	1	11-29	SK301099	Single Knob	NE-6222	1
<b>FINAL ASSEMBLY BLOCK</b>									
11-12x	ZS325495	Tapping Screw #2, 3x6 (BR)		6	11-30	SK607127	Push Knob A (Black)	A5-5022	2
11-13	SP301113	Operation Panel	NE-6210	1	11-31x	MH642857	Head Cover Prop	NE-6009	1
11-14x	ZS447761	Tapping Screw #2, 3x6 (BR) (Black)	/6233	3	11-32	SC301364	Head Cover Part GX-266D		1
11-15	SP301232	Bottom Plate	NE-6202	1	11-33x	ZG301758	Head Cover Spring	NE-6240	2
11-16	SA301411	Square Foot Part GX-215D	2-6-15	2	11-34	SK236970	Power Knob BL	MU-6320	1
11-17x	ZS447480	Screw, binding head 4x12		4	11-35	SK300983	Tape Knob	NE-6234	1
11-18	ZS201341	Screw, truss head 4x8		16	11-36	SK646053	Pinch Roller Cap B NE	ND-6028	1
					11-37	ZS203084	Screw, oval countersunk head 3x8		2
					11-38x	SP301226	Back Board	NE-6211	1
					11-39x	ZS290597	Tapping Screw #2, 3x8 (BR) (W=10)	/6227	2
					11-40x	SA679285	LM Rubber Foot	3-18-5	1
					11-41x	ZW419646	Washer (SPC) D4.5x9.8x0.5t		1
					11-42x	ZS201251	Screw, truss head 4x20		1

When ordering parts, please describe Parts Number, Description and Model Number in detail.

## 12. LIST OF INTERCHANGEABLE SEMICONDUCTORS

As far as service is concerned, in case the original parts cannot be obtained, the interchangeable parts listed below can be substituted.

Original Parts			Interchangeable Parts	
Description	Parts No.	Utilizing P.C Board	Description	Parts No.
2SA564(Q)(R)	ET538154	NE-1213	2SA733(Q)(R)	ET557965
2SA733(P)(Q)	ET554657	NE-5222	2SA564(Q)(R)	ET538154
2SC458LG(C)(D)	ET391768	NE-5223 NE-5222	2SC693U(F) 2SC1312(G)(H)	ET315472 ET517263
2SC945L(P)(Q)	ET639437	NE-5222 NE-1213	2SC536(F)(G)(H) 2SC1647(S)(E)	ET632215 ET592424
2SC1247A(B)(V)	ET511920	NE-1213	2SC1175(E)(F) 2SC1211(E)(F)	ET622080 ET666393
2SC1312S(G)(H)	ET603257	NE-5222	2SC1312(G)(H) 2SC458LG(C)(D)	ET517263 ET391768
2SC1846(Q)(R)	ET301249	NE-1213		
2SD361(D)(E)	ET537300	NE-1213	2SC1098(L)(M)	ET476886
TIP-47	ET621775		2SC1683(P)(Q)	ET635826
1N34A	ED219464	NE-5222	1S188AM 1N60	ED562386 ED428264
1S2473	ED624903	NE-1213	1S1588 WG599	ED557447 ED514721
1S2473VE	ED560913	NE-1213 NE-5222	1S1588 WG599	ED557447 ED514721
1S1588	ED557447	NE-1213	1S2473 WG599	ED624903 ED514721
WZ-240	ED521918	NE-1213	RD24A	ED229072
WZ-130	ED539976	NE-1213		
10D2	ED224548	NE-1213	1N4003	ED570295

COMPOSITION OF VARIOUS P.C BOARDS

AMP P.C BOARD NE-5222

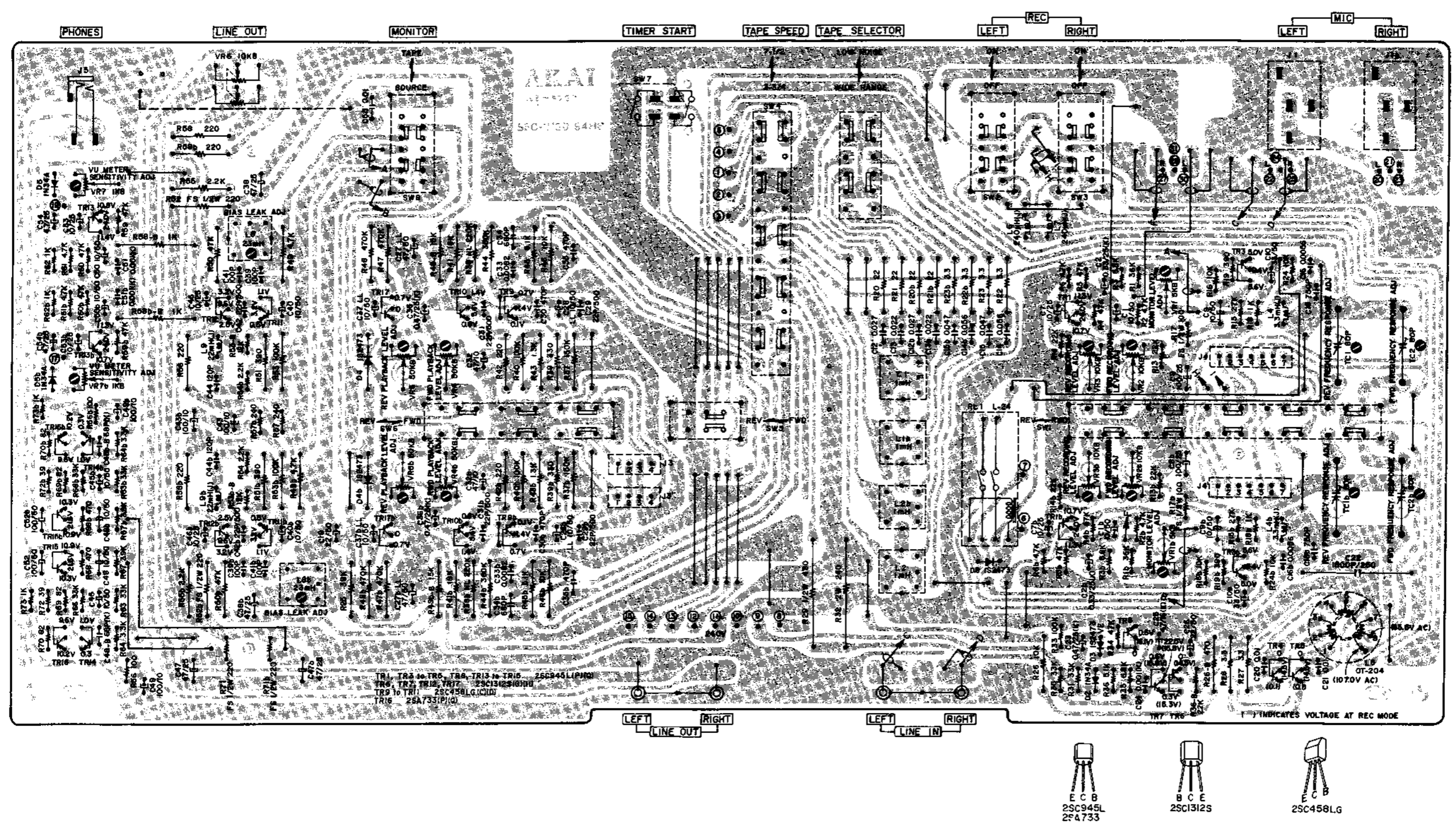

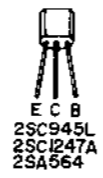
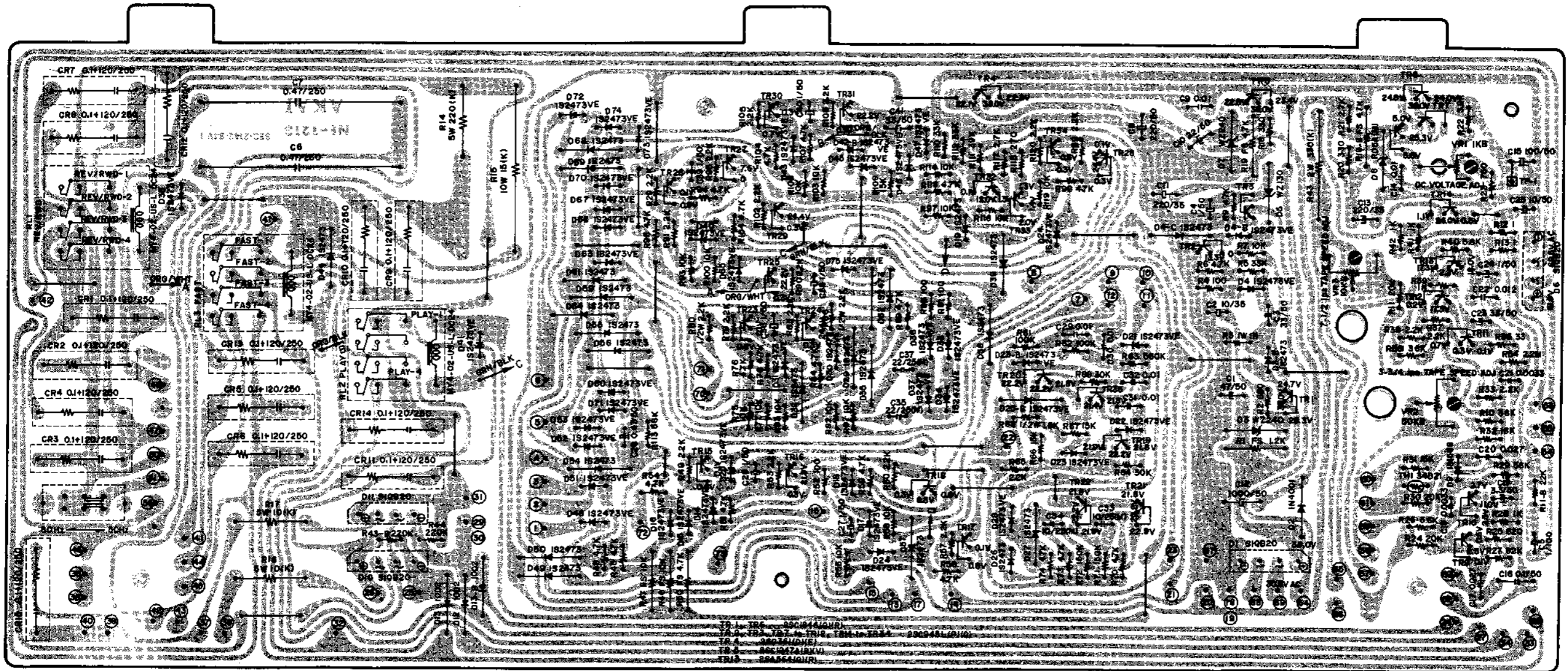



# MIC AMP P.C BOARD NE-5223

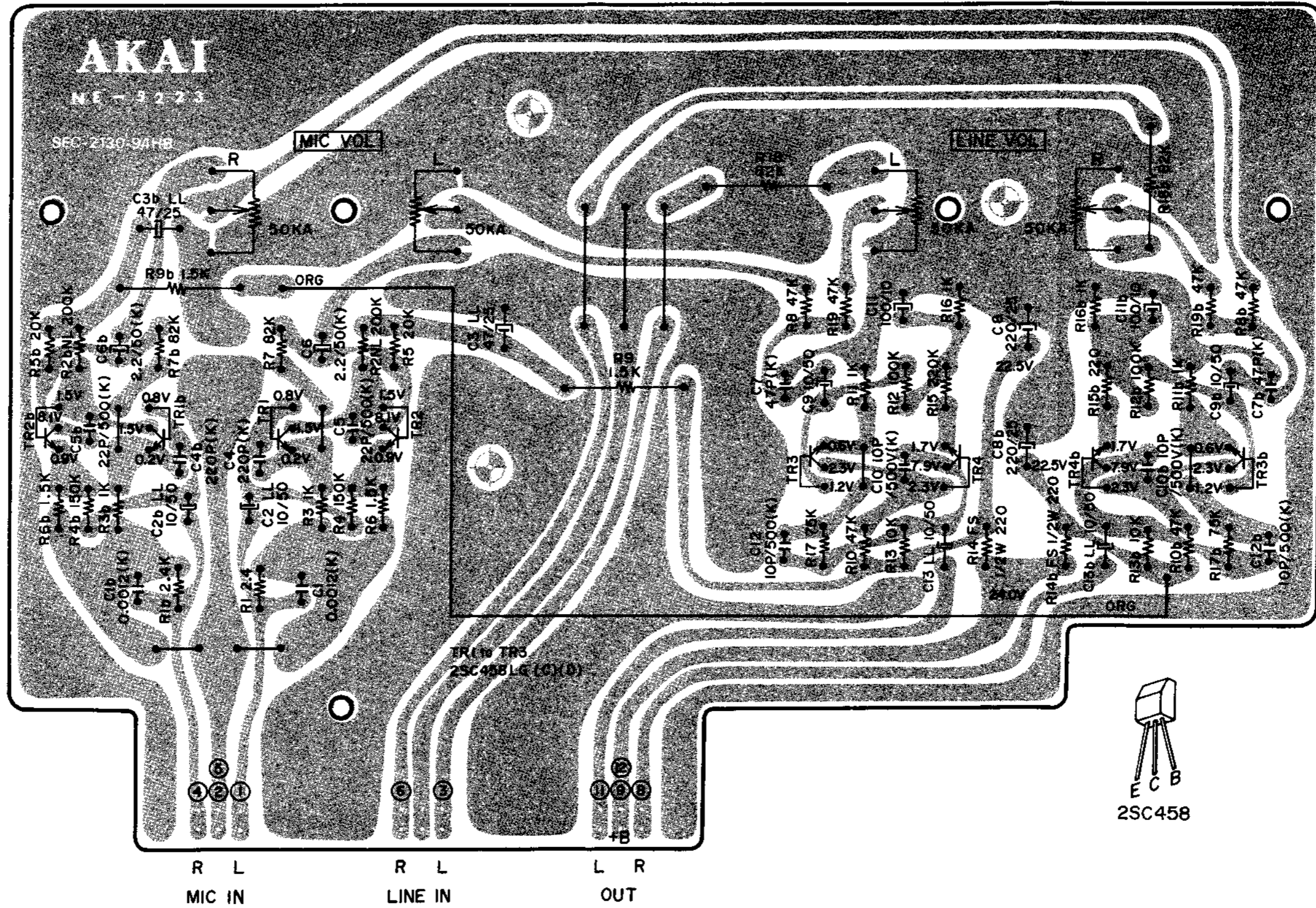



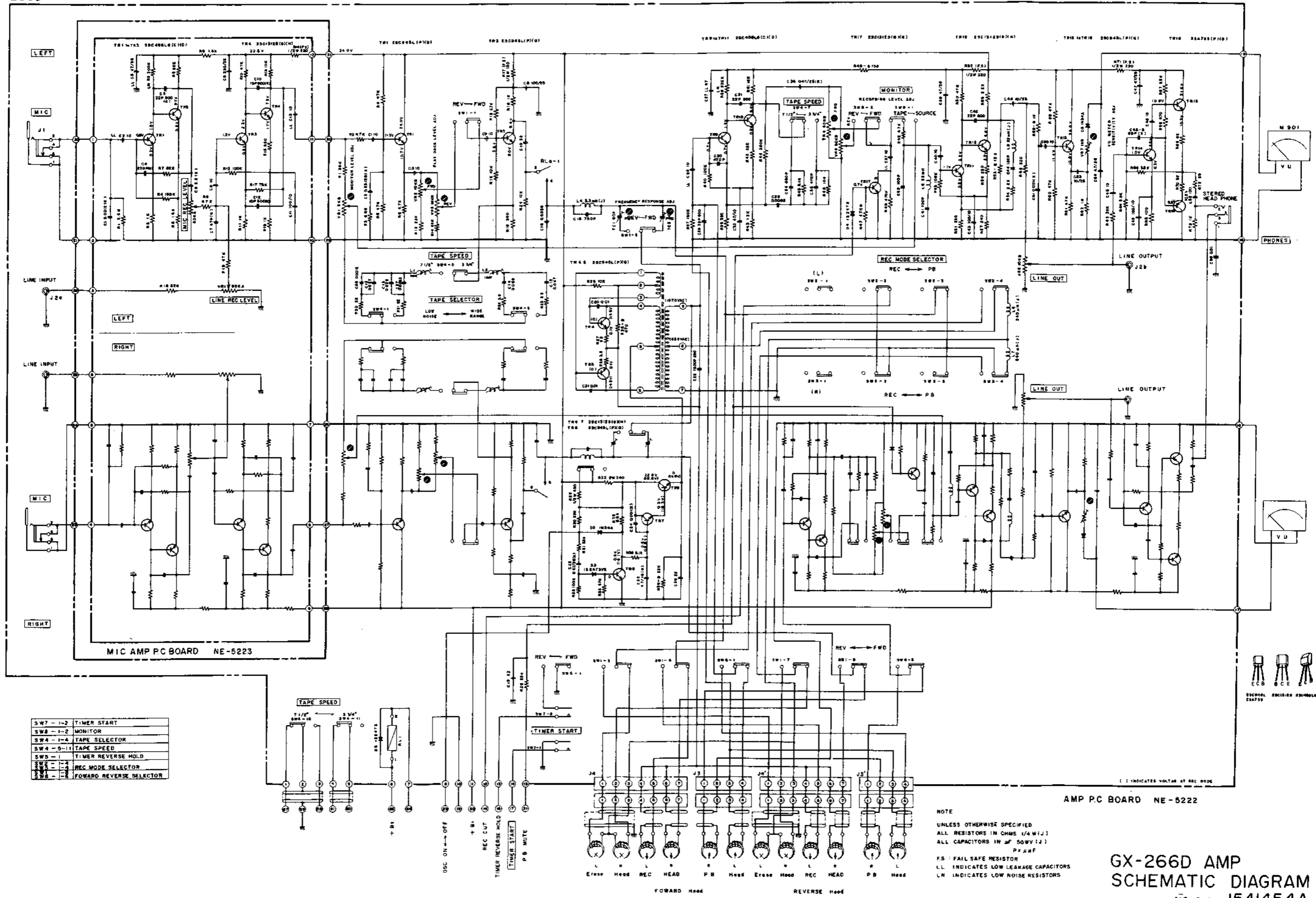

SW7 - 1-2	TIMER START
SW8 - 1-2	MONITOR
SW4 - 1-4	TAPE SELECTOR
SW4 - 3-1	TAPE SPEED
SW5 - 1	TIMER REVERSE HOLD
SW6 - 1	REC MODE SELECTOR
SW6 - 2	FORWARD REVERSE SELECTOR

NOTE  
 UNLESS OTHERWISE SPECIFIED  
 ALL RESISTORS IN OHMS (1/4 W.)  
 ALL CAPACITORS IN  $\mu$ F 50V (1)  
 P = 5%  
 FS : FAIL SAFE RESISTOR  
 LL INDICATES LOW LEAKAGE CAPACITORS  
 LN INDICATES LOW NOISE RESISTORS

GX-266D AMP  
 SCHEMATIC DIAGRAM  
 NO. 2-1 1541454A

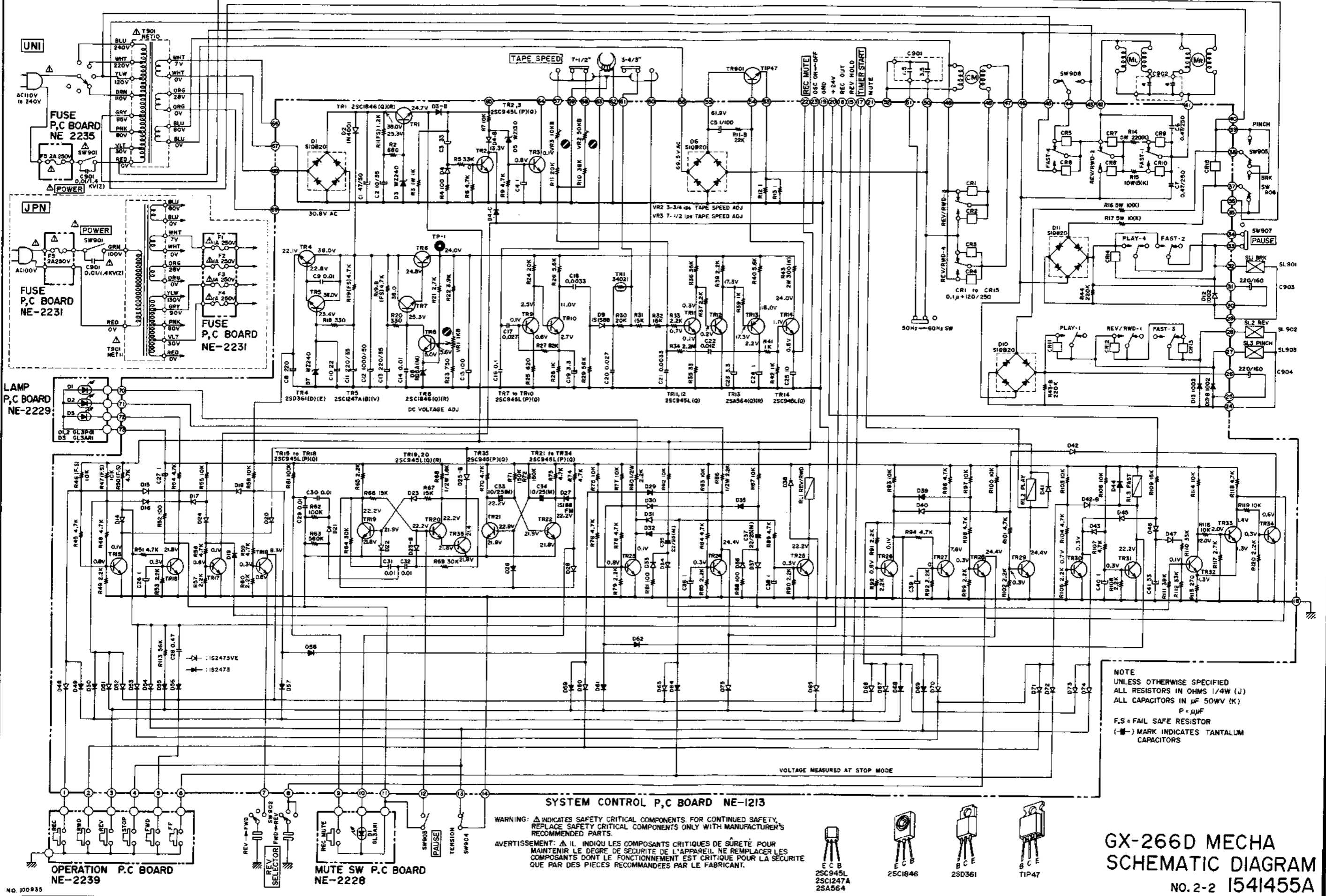

NOTE  
 UNLESS OTHERWISE SPECIFIED  
 ALL RESISTORS IN OHMS 1/4W (J)  
 ALL CAPACITORS IN  $\mu$ F 50WV (K)  
 P =  $\mu$ F  
 F.S. = FAIL SAFE RESISTOR  
 (-) MARK INDICATES TANTALUM CAPACITORS

VOLTAGE MEASURED AT STOP MODE

SYSTEM CONTROL P.C BOARD NE-1213

WARNING:  $\Delta$  INDICATES SAFETY CRITICAL COMPONENTS. FOR CONTINUED SAFETY, REPLACE SAFETY CRITICAL COMPONENTS ONLY WITH MANUFACTURER'S RECOMMENDED PARTS.  
 AVERTISSEMENT:  $\Delta$  IL INDIQU LES COMPOSANTS CRITIQUES DE SURETE. POUR MAINTENIR LE DEGRE DE SECURITE DE L'APPAREIL, NE REMPLACER LES COMPOSANTS DONT LE FONCTIONNEMENT EST CRITIQUE POUR LA SECURITE QUE PAR DES PIECES RECOMMANDEES PAR LE FABRICANT.

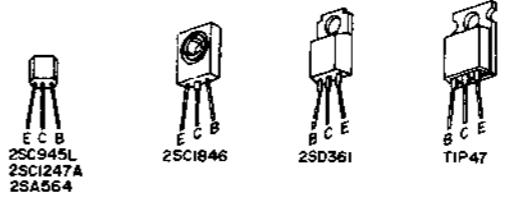

GX-266D MECHA  
 SCHEMATIC DIAGRAM  
 NO. 2-2 1541455A