

ADDITIONAL

 **PIONEER**

Service Manual

**ORDER NO.
ARP1061-A**

FM/AM DIGITAL SYNTHESIZER TUNER

F-X55ZA(BK) ZP

TX-555ZA(BK) ZP

- For servicing these types, please refer to the F-X55ZL (BK)/ZEB service manual (ARP1058) with the exception of this additional service manual.
- This additional service manual is applicable to the F-X55ZA (BK)/ZP and TX-555ZA (BK)/ZP types.
- F-X55ZA (BK)/ZP and TX-555ZA (BK)/ZP are provided with AM stereo demodulation circuit.

PIONEER ELECTRONIC CORPORATION 4-1, Meguro 1-Chome, Meguro-ku, Tokyo 153, Japan
PIONEER ELECTRONICS SERVICE INC. P.O. Box 1780, Long Beach, California 90801 U.S.A. TEL: (213) 420-5700
PIONEER ELECTRONIC (EUROPE) N.V. Keetberglaan 1, 2740 Beveren, Belgium TEL: 03/775-28-08
PIONEER ELECTRONICS AUSTRALIA PTY. LTD. 178-184 Boundary Road, Braeside, Victoria 3195, Australia
TEL: (03) 580-9911

1. CONTRAST OF MISCELLANEOUS PARTS

NOTES:

- Parts without part number cannot be supplied.
- The Δ mark found on some component parts indicates the importance of the safety factor of the part. Therefore, when replacing, be sure to use parts of identical designation.
- For your parts Stock Control, the fast moving items are indicated with the marks **★★** and **★**.
★★ GENERALLY MOVES FASTER THAN ★
 This classification shall be adjusted by each distributor because it depends on model number, temperature, humidity, etc.
- Parts marked by "●" are not always kept in stock. Their delivery time may be longer than usual or they may be unavailable.

The F-X55ZA (BK)/ZP and TX-555ZA (BK)/ZP types are the same as the F-X55ZL (BK)/ZEB type with the exception of the following sections.

Mark	Symbol & Description	Part No.			Remarks
		F-X55ZL(BK)/ZEB	F-X55ZA(BK)/ZP	TX-555ZA(BK)/ZP	
	PVC panel	AAK1009	AAK1037	AAK1091	
	Front panel	AMB1002	AMB1072	AMB1071	
	Bonnet case	ANE1003	ANE1003	ANE1028	
	Packing case	AHD1008	AHD1091	AHD1092	
	Supplementary instructions	ARR-05 i	ARR-084	ARR-084	
	Tuner assembly	GWE-270	GWE-275	GWE-275	
	AM MPX assembly	...	AWD-018	AWD-018	

2. ELECTRICAL PARTS LIST

NOTES:

- When ordering resistors, first convert resistance values into code form as shown in the following examples.
 Ex. 1 When there are 2 effective digits (any digit apart from 0), such as 560 ohm and 47k ohm (tolerance is shown by J = 5%, and K = 10%).
 560Ω 56 × 10¹ 561..... RD1/4PS \square \square \square J
 47kΩ 47 × 10³ 473..... RD1/4PS \square \square \square J
 0.5Ω 0R5..... RN2H \square \square \square K
 1Ω 010..... RS1P \square \square \square K
- Ex. 2 When there are 3 effective digits (such as in high precision metal film resistors).
 5.62kΩ 562 × 10¹ 5621..... RN1/4SR \square \square \square \square F
- The Δ mark found on some component parts indicates the importance of the safety factor of the part. Therefore, when replacing, be sure to use parts of identical designation.
- For your parts Stock Control, the fast moving items are indicated with the marks **★★** and **★**.
★★ GENERALLY MOVES FASTER THAN ★
 This classification shall be adjusted by each distributor because it depends on model number, temperature, humidity, etc.
- Parts marked by "●" are not always kept in stock. Their delivery time may be longer than usual or they may be unavailable.

MISCELLANEOUS PARTS

Mark	Symbol & Description	Part No.
	Tuner assembly	GWE-275
	Switch assembly	Non supply
	LED assembly	Non supply
	AM MPX assembly	AWD-018
	FM antenna	AHD-005
L1	Loop antenna assembly	ATB-102

Tuner Assembly (GWE-275)

SEMICONDUCTORS

Mark	Symbol & Description	Part No.
★★	IC301 MPX IC	AN7470P
★★	IC401 AM/FM IC	LA1260S
★★	IC702 PLL IC	TC9157AP
★★	IC701 PLL IC	TD6104P
★★	IC703 DISPLAY IC	TD6301AP
★★	Q304, Q408, Q605, Q607	2SA1048 (2SA933S)
★★	Q407	2SA933S
★★	Q401	2SC1740S
★★	Q701, Q702	2SC1740SLN
★★	Q301 - Q303, Q402 - Q404, Q606, Q608, Q703, Q707	2SC2458 (2SC1740S)
★★	Q103, Q201	2SC2668
★★	Q102	2SC2786
★★	Q104, Q105, Q406	2SK161 (2SK241)
★★	Q101	2SK241
★	D405, D605	RD5.6EB (HZ5.6EB)
★	D401, D402	SVC321C2/D2
★	D720	1SS131
★	D301, D404, D406 - D410, D702 - D704, D707 - D709	1SS131
★	D101 - D103	1SV147

SWITCHES

Mark	Symbol & Description	Part No.
★★	S3 - S11, S15, S16 Tact switch (STATION CALL, MEMORY) AM, FM	ASG-711 (ASG-703)

COILS, TRANSFORMERS AND FILTERS

Mark	Symbol & Description	Part No.
	L401 AM OSC coil	ATB-110
	L101 FM ANT coil	ATC-192
	L102 FM ANT coil	ATC-193
	L103 FM OSC coil	ATC-214
	L202 FM DET coil	ATE-072
	L203 Inductor	ATH-116
	L104, L105, L201 Inductor	ATH-049
	T401 AM ANT transformer	ATB-099
	T402 AM IF transformer	ATB1002
	T101 FM RF transformer	ATC-194
	T102 FM matching transformer	ATE-063

Mark	Symbol & Description	Part No.
	F202 FM ceramic filter	ATF-107
	F201 FM ceramic filter	ATF-119
	F401 AM ceramic filter	ATF1004

CAPACITORS

Mark	Symbol & Description	Part No.
	C713 Electrolytic (3300μF/10V)	ACH-389
	TC401, TC402 Ceramic trimmer	ACM-015
	C716	CCCCH180J50 (CCDCH180J50)
	C416, C718	CCCSL221J50 (CCDSL221J50)
	C117, C401	CCDCH080D50
	C115, C404, C717	CCDCH150J50
	C116	CCDCH330J50
	C101, C102, C105, C106	CCDRH390J50
	C108	CCDSL020C50
	C109, C111, C112	CCDSL050C50
	C110, C426	CCDSL101J50
	C119	CCDTH180J50
	C422	CEANP4R7M35
	C308, C427	CEASR22M50
	C425, C702, C709, C711, C712	CEAS010M50
	C306, C705	CEAS1R5M50
	C418, C605, C607, C723	CEAS100M25
	C312, C313, C423	CEAS2R2M50
	C303, C604	CEAS221M16
	C301, C302, C307, C701	CEAS3R3M50
	C703	CEAS330M16
	C406	CEAS4R7M50
	C311, C414	CEAS470M25
	C720	CEAS471M16
	C714	CEAS471M6
	C309, C310, C410, C411	CKCYB102K50 (CKDYB102K50)
	C314, C315	CKCYB472K50 (CKDYB472K50)

C305, C412, C413, C419, C710	CKCYF473Z50 (CKDYF473Z50)
C415	CKCYX473M25 (CKDYX473M25)
C104, C107, C113, C114, C118, C201, CKDYF103Z50	CKDYF103Z50
C403, C420, C450, C704, C706 - C708, C721, C722, C724	

C103, C121, C214, C402, C407, C408, CKDYF223Z50	CKDYF223Z50
C715, C719	
C405	QOSA431J50
C304	QOSA471J50

RESISTORS

NOTE: When ordering resistors, convert the resistance value into code form, and then rewrite the part no. as before.

Mark	Symbol & Description	Part No.
★	VR301 Semi-fixed (4.7kΩ)	VRTB6VS472
★	VR401 Semi-fixed (220kΩ)	VRTB6VS224
△	R601 Metal oxide	RS1LMF151J
	R720, C421 Resistor array	RA12S473J
	R404, R421, R431, R432	RD1/4PM□□□J
	Other resistors	RD1/8PM□□□J

OTHERS

Mark	Symbol & Description	Part No.
	Terminal (ANTENNA) (PAL, 4P)	AKA1002
	Socket (6P)	AKP-083
★	V1 Fluorescent tube	AAV-028
★	X701 Crystal resonator	ASS-025

Switch Assembly

SWITCHES

Mark	Symbol & Description	Part No.
★★	S12, S13 Tact switch (UP-DOWN)	ASG-711 (ASG-703)

LED Assembly

SEMICONDUCTORS

Mark	Symbol & Description	Part No.
★	D901 LED (STEREO)	AEL-382
★	D902 LED (TUNED)	AEL-424

AM MPX Assembly (AWD-018)

SEMICONDUCTORS

Mark	Symbol & Description	Part No.
★★	IC901	MC13020P
★★	Q904, Q910	2SA933S (2SA1115)
★★	Q902, Q903, Q905 – Q908, Q911	2SC1740S (2SC2603)
★★	Q901	2SC2668
★★	Q909	2SC3400
★	D903	RD9.1EB (HZ:9.1EB)
★	D902	1SS131
★	TH901	TH103

COIL

Mark	Symbol & Description	Part No.
	L901 Inductor	ATH-116

CAPACITORS

Mark	Symbol & Description	Part No.
	C915	CCDCH470J50
	C916, C917	CEASR47M50
	C902, C910	CEAS100M25
	C933	CEAS101M16
	C904, C911, C919, C931, C932	CEAS2R2M50
	C934, C936	CEAS220M25
	C935	CEAS330M16
	C903, C918, C920	CEAS4R7M50
	C912	CEAS470M10
	C909	CKCYB102K50 (CKDYB102K50)
	C906 – C908, C913	CKCYB332K50 (CKDYB332K50)
	C929, C930	CKCYB222K50 (CKDYB222K50)
	C901, C905, C914	CKCYF103Z50
	C923 – C928	CQMA154J50

RESISTORS

NOTE: When ordering resistors, convert the resistance value into code form, and then rewrite the part no. as before.

Mark	Symbol & Description	Part No.
★	VR901 Semi-fixed (22k)	VRTB6VS223
	Other resistors	RD1/8PM □□□J

OTHERS

Mark	Symbol & Description	Part No.
★	X901 Ceramic resonator	ASS-045

3. P. C. BOARDS CONNECTION DIAGRAM

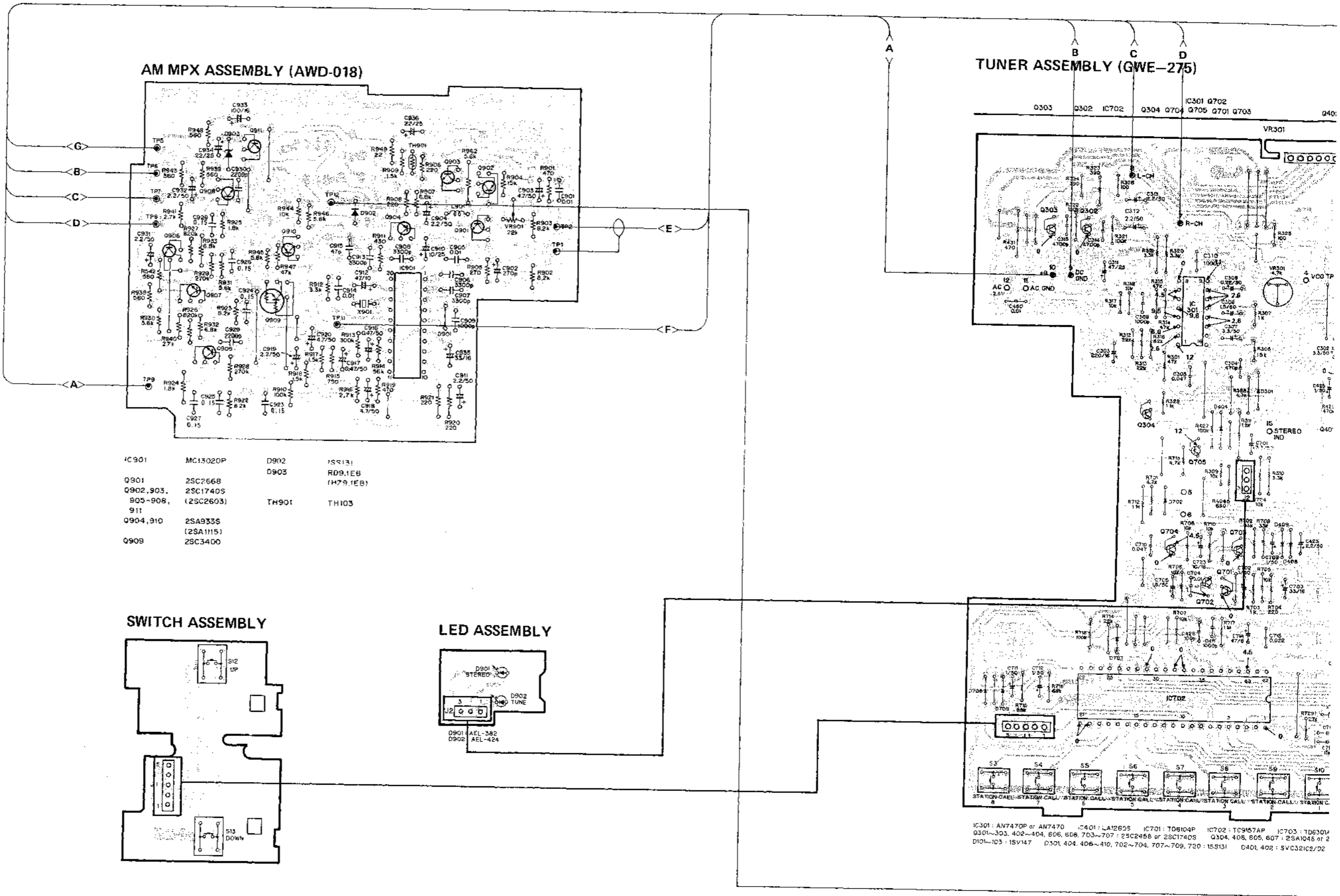

4

5

6

7

8

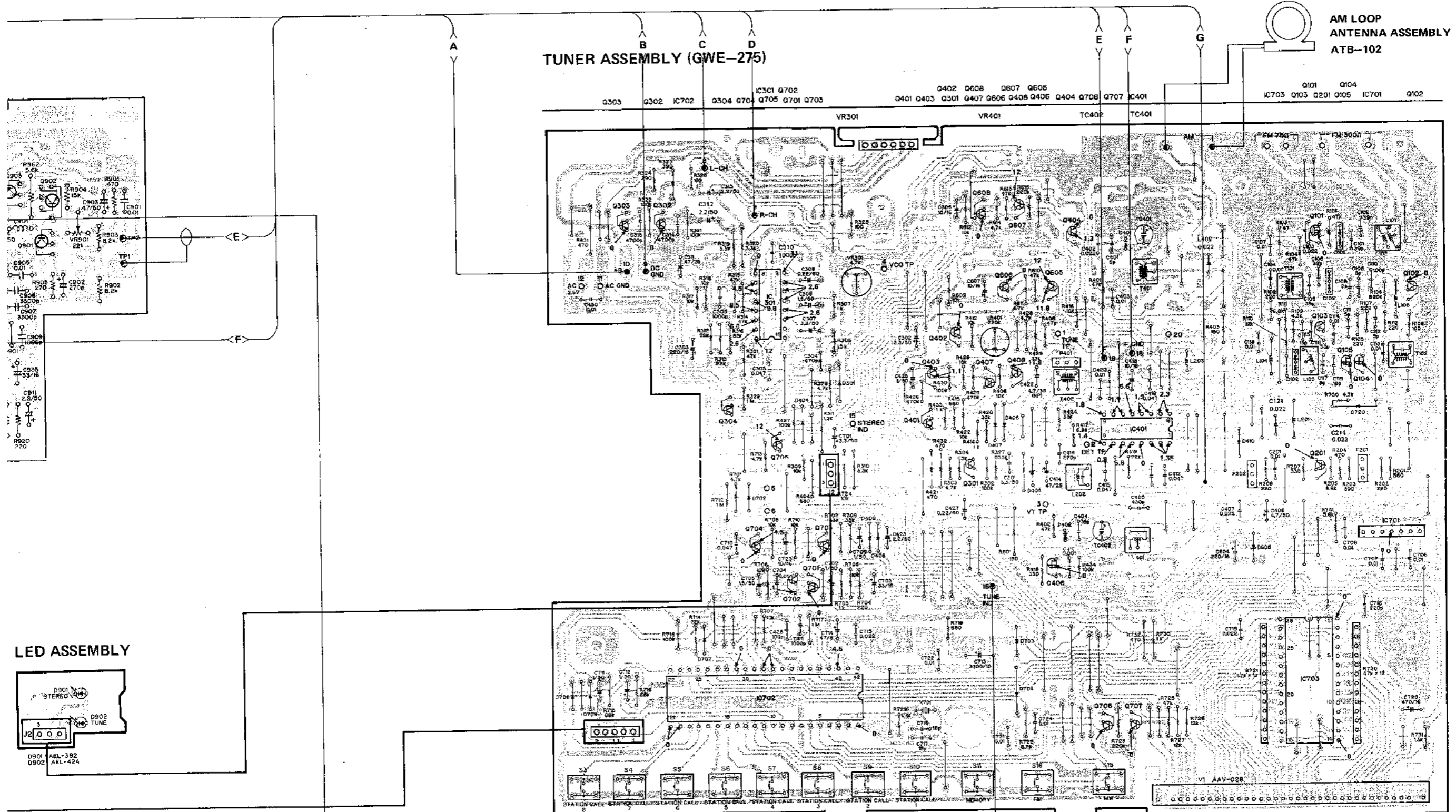

LED ASSEMBLY

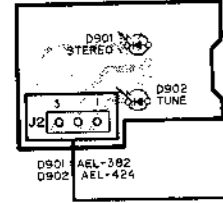

IC301: AN7470P or AN7470 IC401: LA12605 IC701: TD6104P IC702: TC915TAP IC703: TD6301AP Q101: 2SK241 Q102: 2SC2786 Q103, 201: 2SC2668 Q104, 105, 406: 2SK161 or 2SK241
Q301~303: 402~404, 608, 609, 703~707: 2SC245B or 2SC17405 Q304, 408, 605, 607: 2SA1048 or 2SA9335 Q401: 2SC17403 Q407: 2SA9335 Q701, 702: 2SC1740SLN
Q101~103: 1SV147 Q301, 404, 406~410, 702~704, 707~709, 720: 155131 C401, 402: SVC321C/D2 D4C5, 605: RD5.6EB or H25.6EB

4

5

6

7

8

9

4. SCHEMATIC DIAGRAM

TUNER ASSEMBLY (GWE-275)

A

B

C

D

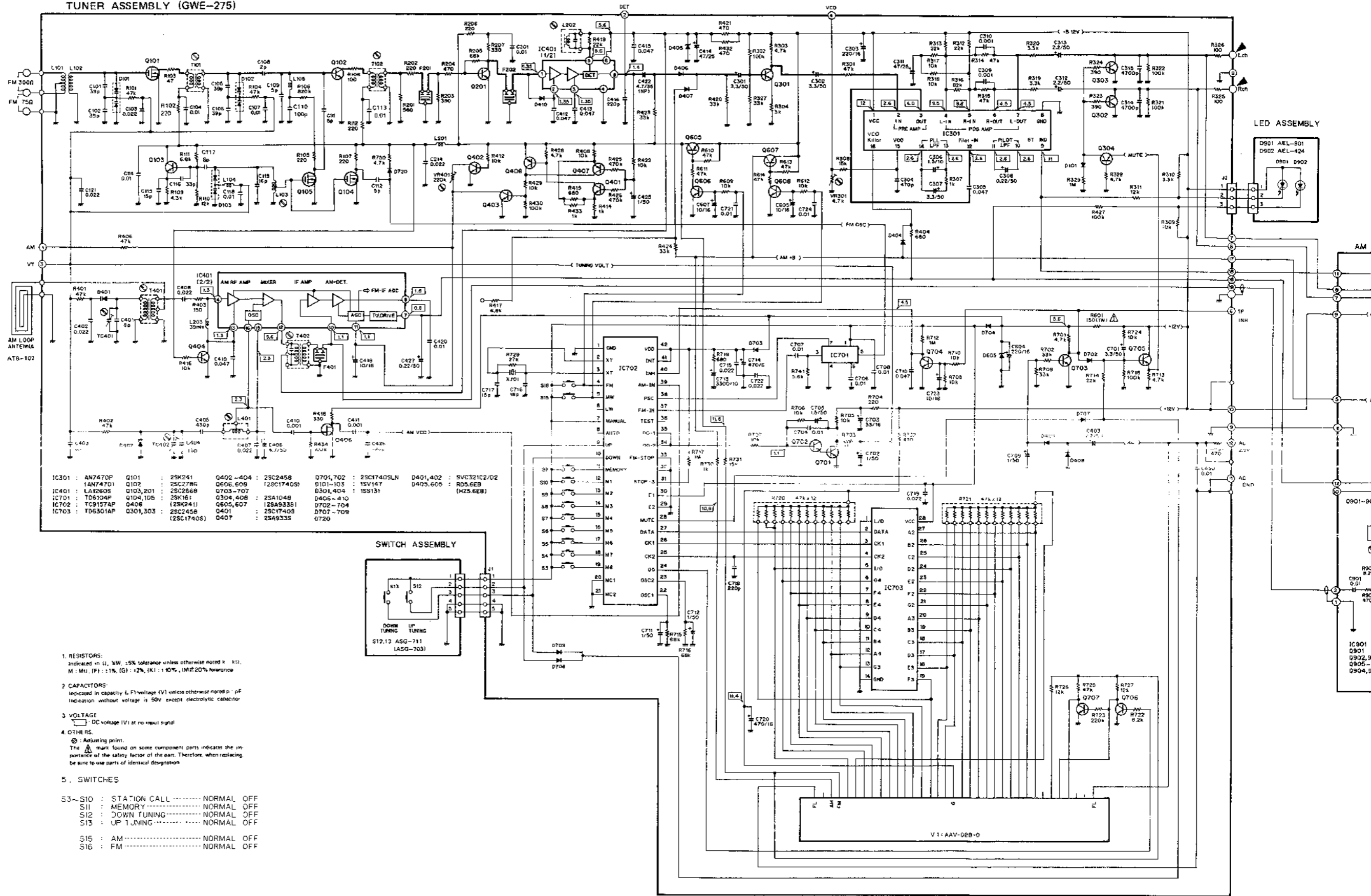

IC301 : AN7470P	Q101 : 2SK241	Q402-404 : 2SC2458	D701,702 : 2SC1740SLN	D401,402 : SVC321C2/D2
IC401 : LA12605	Q102 : 2SC2798	Q606,609 : 2SC1740S	D101-103 : 15V147	D405,605 : R05.6EB
IC701 : TD6104P	Q103,201 : 2SC2658	Q703-707 : 2SA1048	D301,404 : 15S131	
IC702 : TC9157AP	Q408 : 2SK241	Q605-410 : 2SA933S1	D702-704 : 2SC1740S	
IC703 : TD6301AP	Q301,303 : 2SC2458	Q401 : 2SC1740S	D707-709 : 2SC1740S	
	Q302 : 2SC1740S	Q407 : 2SA933S	Q720 : 2SC1740S	

- RESISTORS:**
Indicated in Ω, kΩ, MΩ, 5% tolerance unless otherwise noted. K, 10k, M, 1M, 10M, 100M, 1G, 10G, 100G, 1T, 10T, 100T, 1P, 10P, 100P, 1N, 10N, 100N, 1000, 10000, 100000, 1000000.
- CAPACITORS:**
Indicated in capacity & F (voltage V) unless otherwise noted. pF, nF, μF, 1000pF, 1nF, 10nF, 100nF, 1μF, 10μF, 100μF, 1mF, 10mF, 100mF, 1F, 10F, 100F, 1000, 10000, 100000, 1000000.
- VOLTAGE:**
DC voltage (V) at no input signal.
- OTHERS:**
⊗: Adjusting point.
⚠: The mark found on some component parts indicates the importance of the safety factor of the part. Therefore, when replacing, be sure to use parts of identical designation.
- SWITCHES:**
S3~S10 : STATION CALL NORMAL OFF
S11 : MEMORY NORMAL OFF
S12 : DOWN TUNING NORMAL OFF
S13 : UP TUNING NORMAL OFF
S15 : AM NORMAL OFF
S16 : FM NORMAL OFF

NOTE:
 The indicated semiconductors are representative ones only. Other alternative semiconductors may be used and are listed in the parts list.

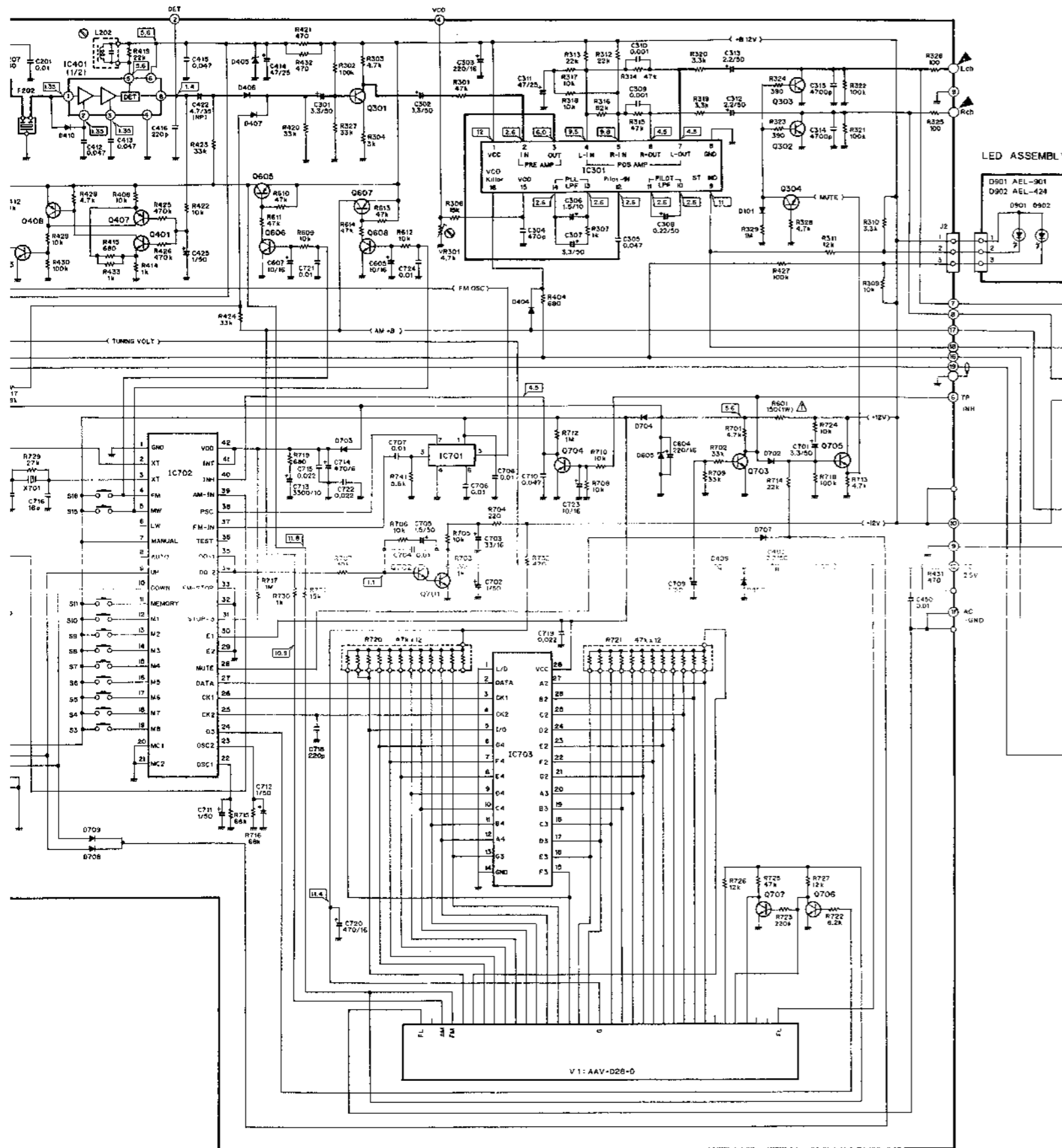

LED ASSEMBLY

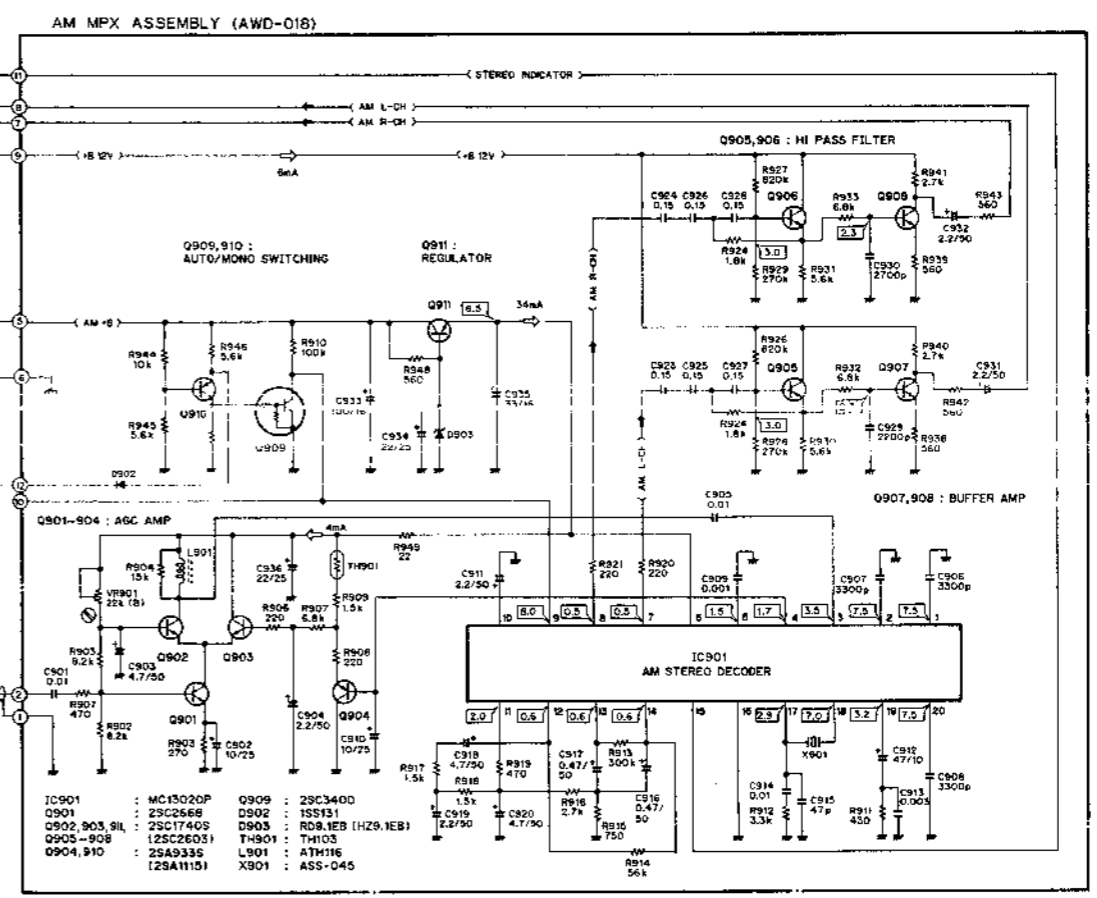

- | | | | |
|----------------|------------|-------|---------------------|
| IC901 | : MC1302DP | Q909 | : 2SC3400 |
| Q901 | : 2SC2568 | D902 | : 1SS131 |
| Q902, 903, 904 | : 2SC1740S | D903 | : RD8,1EB (HZ9,1EB) |
| Q905-908 | : 2SC2603 | T-901 | : T-1103 |
| Q904, 910 | : 2SA933S | L901 | : ATM116 |
| | (2SA1115) | X901 | : ASS-045 |

5. ADJUSTMENTS

- For servicing these types, please refer to the F-X55ZL (BK) adjustments in service manual (ARP1058: from page 17 to 22) with the exception of this adjustment.

• AM (MW) Tuner Section Adjustment

Step No.	AM SG (400 Hz, 30% modulation)		TX-555ZA (BK) F-X55ZA (BK) tuned frequency display	Adjustment	
	Frequency (kHz)	Level (dB)		Adjustment location	Specifications
1	No input signal		531 kHz	L401	Set pin 3 of tuner assembly to 1.3V ($\pm 0.1V$).
2			1602 kHz	TC402	Set pin 3 of tuner assembly to 10.0V ($\pm 0.3V$).
3	Repeat steps 1 and 2 until both specification ratings are satisfied.				
4	603	40	603 kHz	T401	Set the output from pin 1 of the tuner assembly to maximum level.
5	1395	40	1395 kHz	TC401	
6	Repeat steps 4 and 5 until both specification ratings are satisfied.				
7	—	100	—	VR901*	Set the output level of AM MPX assembly to -16.5 dB ± 1 dB.
8	1395	Variable	1395 kHz	Check that the TUNING indicator comes on when the AM SG level is gradually increased.	

*VR901 is in AM MPX assembly (AWD-018) (See Fig. 5-1)

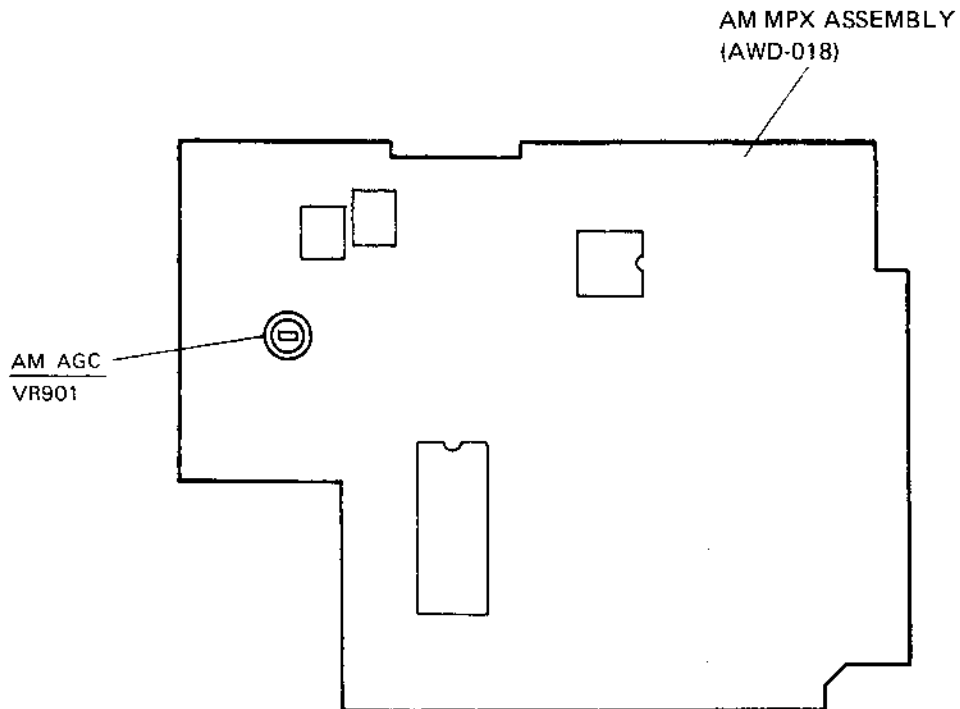

Fig.5-1 Adjustment position

 PIONEER®

Service Manual

**CIRCUIT DESCRIPTIONS
REPAIR & ADJUSTMENTS**



**ORDER NO.
ARP1058-0**

FM/AM DIGITAL SYNTHESIZER TUNER

F-X55ZL(BK)

F-X55ZL

• MODELS F-X55ZL (BK), F-X55Z (BK), F-X55ZA (BK) AND F-X55ZL COME IN FIVE VERSIONS DISTINGUISHED AS FOLLOWS:

Type	Applicable model				Power requirement	Export destination
	F-X55ZL	F-X55ZL(BK)	F-X55Z(BK)	F-X55ZA(BK)		
ZEB	○	○	—	—	(DC power supply)	European continent and United Kingdom
ZUC	—	—	○	—	(DC power supply)	U.S.A and Canada
Z	—	—	○	—	(DC power supply)	European continent
ZEZ	—	—	○	—	(DC power supply)	West Germany
ZP	—	—	—	○	(DC power supply)	Australia

- This service manual is applicable to the ZEB type.
- As to the F-X55Z (BK)/ZUC and Z, please refer to the additional service manual (ARP1059).
- F-X55ZL is the same as the F-X55ZL (BK) except for the exterior design (color).
- F-X55ZL is silver version of F-X55ZL (BK).
- The AM tuner of the F-X55ZL (BK) is a two wave-band tuner with MW (medium wave) and LW (long wave), but the F-X55Z (BK) is MW only.
- As to the F-X55Z (BK)/ZEZ type, please refer to the additional service manual (ARP1060).
- As to the F-X55ZA (BK)/ZP type, please refer to the additional service manual (ARP1061).
- Model F-X55ZA (BK) has the same configuration as model F-X55ZL (BK) except that the former equipped with AM stereo circuitry rather than LW (long wave) circuitry.
- Ce manuel d'instruction se réfère au mode de réglage en français.
- Este manual de servicio trata del método ajuste escrito en español.

PIONEER ELECTRONIC CORPORATION 4-1, Meguro 1-Chome, Meguro-ku, Tokyo 153, Japan
PIONEER ELECTRONICS SERVICE AND ENGINEERING, INC. P.O. Box 1760, Long Beach, California 90801 U.S.A.
TEL: (213) 420-5700
PIONEER ELECTRONIC (EUROPE) N.V. Keetbergplein 1, 2740 Beveren, Belgium TEL: 03/775-28-08
PIONEER ELECTRONICS AUSTRALIA PTY. LTD. 178-184 Boundary Road, Braeside, Victoria 3185, Australia
TEL: (03) 580-9911

FI © JAN. 1986 Printed in Japan

CONTENTS

1. SAFETY INFORMATION	2	8. PACKING	9
2. SPECIFICATIONS	3	9. P.C. BOARD CONNECTION DIAGRAM	11
3. PANEL FACILITIES	3	10. SCHEMATIC DIAGRAM	13
4. PARTS LOCATION	4	11. ELECTRICAL PARTS LIST	15
5. BLOCK DIAGRAM	5	12. ADJUSTMENT	17
6. IC DESCRIPTION	7	RÉGLAGE	19
7. EXPLODED VIEW	8	AJUSTE	21

1. SAFETY INFORMATION

1. SAFETY PRECAUTIONS

The following check should be performed for the continued protection of the customer and service technician.

LEAKAGE CURRENT CHECK

Measure leakage current to a known earth ground (water pipe, conduit, etc.) by connecting a leakage current tester such as Simpson Model 229-2 or equivalent between the earth ground and all exposed metal parts of the appliance (input/output terminals, screwheads, metal overlays, control shaft, etc.). Plug the AC line cord of the appliance directly into a 120V AC 60Hz outlet and turn the AC power switch on. Any current measured must not exceed 0.5mA.

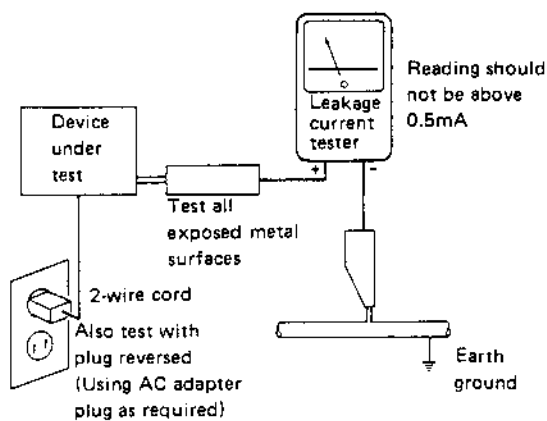

AC Leakage Test

ANY MEASUREMENTS NOT WITHIN THE LIMITS OUTLINED ABOVE ARE INDICATIVE OF A POTENTIAL SHOCK HAZARD AND MUST BE CORRECTED BEFORE RETURNING THE APPLIANCE TO THE CUSTOMER.

2. PRODUCT SAFETY NOTICE

Many electrical and mechanical parts in the appliance have special safety related characteristics. These are often not evident from visual inspection nor the protection afforded by them necessarily can be obtained by using replacement components rated for voltage, wattage, etc. Replacement parts which have these special safety characteristics are identified in this Service Manual.

Electrical components having such features are identified by marking with a ⚡ on the schematics and on the parts list in this Service Manual.

The use of a substitute replacement component which does not have the same safety characteristics as the PIONEER recommended replacement one, shown in the parts list in this Service Manual, may create shock, fire, or other hazards.

Product Safety is continuously under review and new instructions are issued from time to time. For the latest information, always consult the current PIONEER Service Manual. A subscription to, or additional copies of, PIONEER Service Manual may be obtained at a nominal charge from PIONEER.

2. SPECIFICATIONS

FM Tuner Section

Frequency range	87.5 MHz to 108 MHz
Usable Sensitivity	11.2 dBf, (HF (1.0 μ V/75 ohms)
Sensitivity (DIN)	Mono: 0.9 μ V/75 ohms
	Stereo: 31.5 μ V/75 ohms
Signal-to-Noise Ratio (HF, 85 dBf Input)	Mono: 77 dB
	Stereo: 73 dB
Signal-to-Noise Ratio (DIN)	Mono: 66 dB
	Stereo: 60 dB
Distortion	Stereo: 0.4% (1 kHz)
Alternate Channel Selectivity	67 dB (400 kHz)
Stereo Separation	40 dB (1 kHz)
Antenna Input	300 ohm balanced
	75 ohm unbalanced

MW (AM) Tuner Section

Frequency range	530 kHz to 1600 kHz when 10 kHz step
	531 kHz to 1602 kHz when 9 kHz step
Sensitivity (HF, Loop antenna)	300 μ V/m
Signal-to-Noise Ratio	50 dB
Antenna	Loop Antenna

LW Tuner Section (For LW-equipped models only)

Frequency range	153 kHz to 281 kHz
-----------------------	--------------------

Miscellaneous

Dimensions	360(W) x 56(H) x 215(D) mm
	14-3/16(W) x 2-3/16(H) x 8-7/16(D) in
Weight (without package)	1.8 kg (4 lb)

Furnished Parts

FM T-type Antenna	1
AM Loop Antenna	1
Tuner input/output cord	1

NOTE:

Specifications and the design subject to possible modifications without notice due to improvements.

3. PANEL FACILITIES

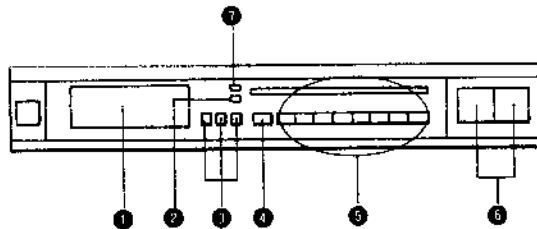

NOTE:

The illustration is of the model for use in continental Europe and the U.K.

1 FREQUENCY display

Permits reading the received frequency at a glance from the displayed figure. The FM band is indicated by MHz, and the AM (MW or LW) band by kHz.

2 STEREO indicator

This lights when a stereo program has been picked up during an FM broadcast.

3 FUNCTION switch

MW: Push to receive MW band broadcasts.
LW: Push to receive LW band broadcasts.
FM: Push to receive FM band broadcasts.

Only AM/FM switching is available for the other models.

4 MEMORY switch

Push to operate the memory circuit. After the switch is pressed, the memory circuit will function for about ten seconds. During this time, press one of the STATION CALL switches to memorize the station being currently received. If more than ten seconds elapse after the MEMORY switch is pressed, no stations can be memorized. In this case, press the MEMORY switch again if you wish to memorize a station.

5 STATION CALL switches

These are used to preset and recall broadcasting stations. A total of 16 stations can be preset (FM: 8, AM (MW or LW): 8).

- To tune in to a prememorized station, push the appropriate STATION CALL switch.
- Once the stations have been preset, all you have to do to recall them is push the STATION CALL switch.

6 TUNING switches

These are used to locate the stations. Push either of these two switches; the left switch "-" to go to a lower, and the right switch "+" to go to a higher frequency.

7 TUNED indicator

This lights to indicate when the finest tuning of a station has been achieved.

4. PARTS LOCATION

NOTES:

- Parts without part number cannot be supplied.
- The Δ mark found on some component parts indicates the importance of the safety factor of the part. Therefore, when replacing, be sure to use parts of identical designation.
- For your parts Stock Control, the fast moving items are indicated with the marks **★★** and **★**.
★★ GENERALLY MOVES FASTER THAN ★
 This classification shall be adjusted by each distributor because it depends on model number, temperature, humidity, etc.
- Parts marked by "⊙" are not always kept in stock. Their delivery time may be longer than usual or they may be unavailable.

Front Panel View

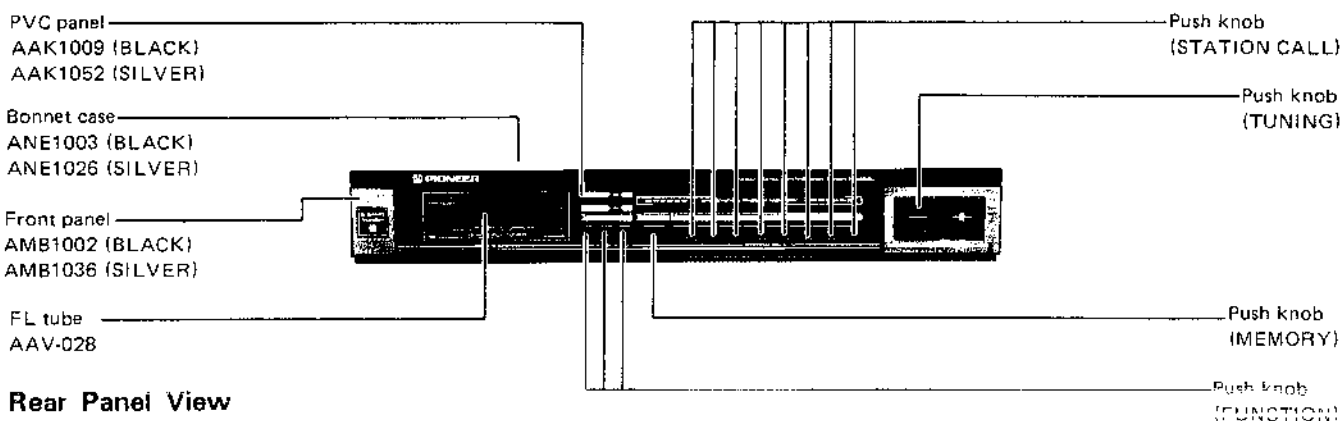

Rear Panel View



Top View

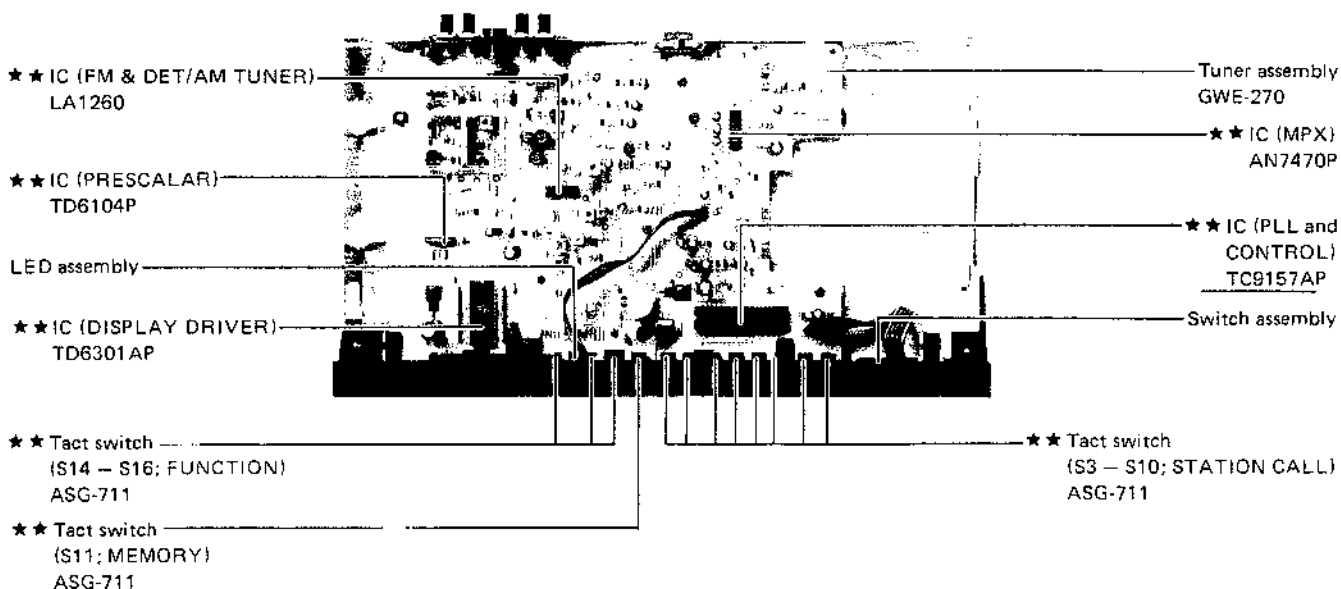

5. BLOCK DIAGRAM

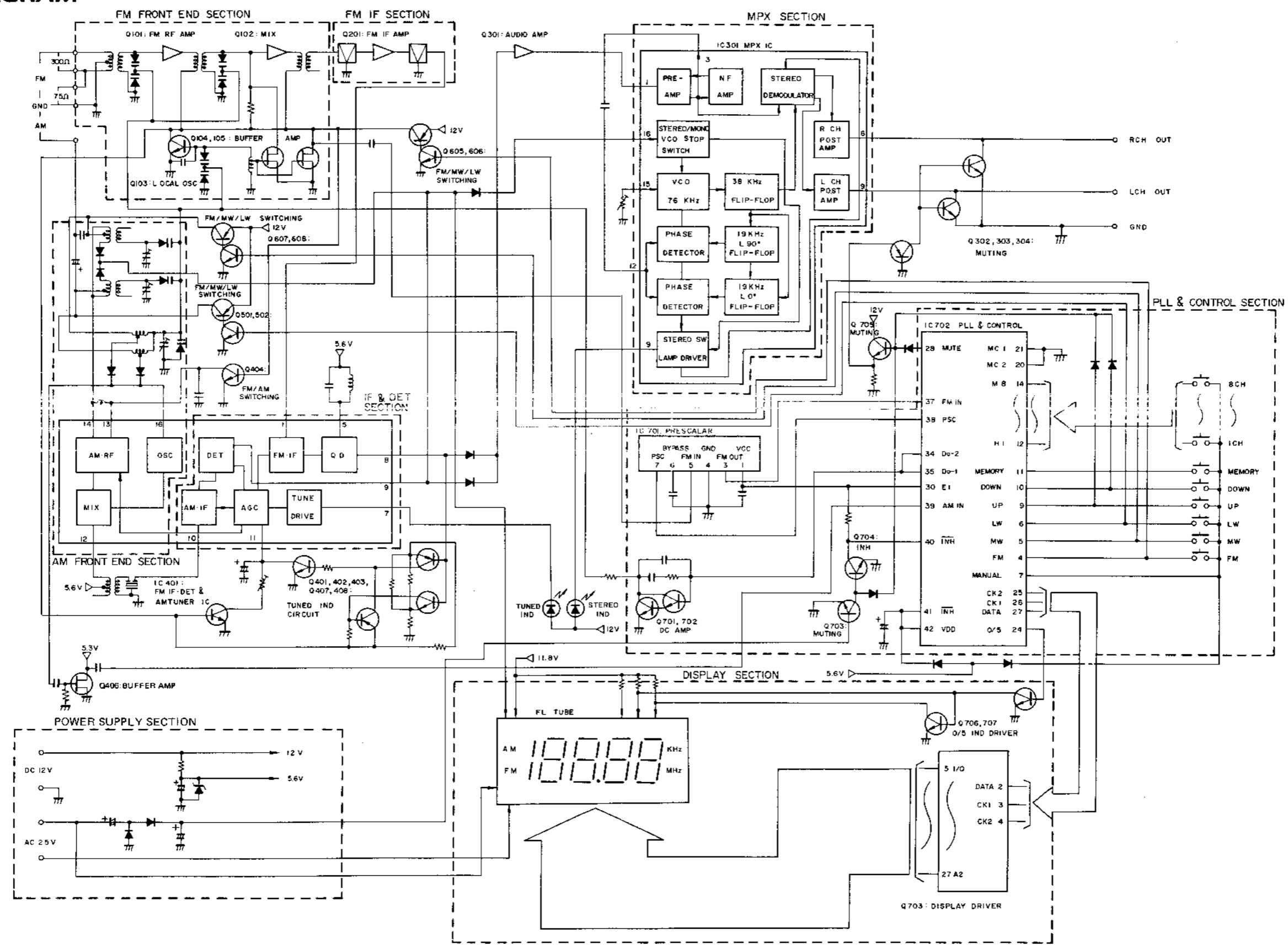

6. IC DESCRIPTION

• IC (LA1260) PIN DESCRIPTION

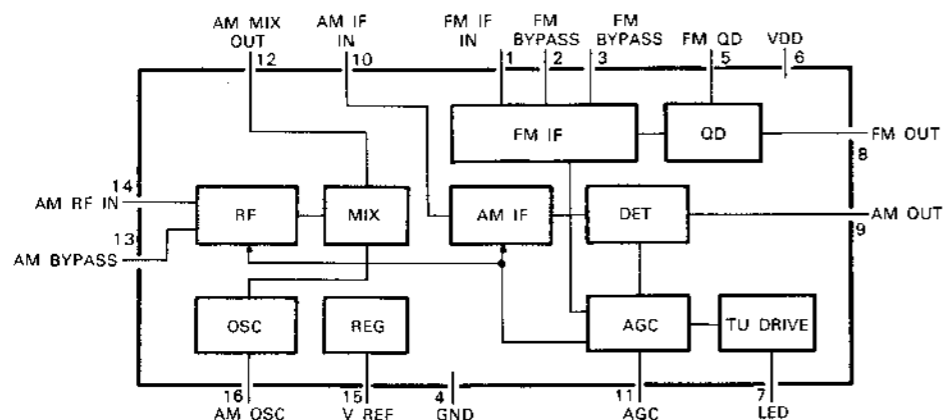

Fig. 6-1 LA1260 Block diagram

Pin No.	Pin Name	Pin No.	Pin Name
1	FM-IF input	9	AMDET output
2	FM bypass capacitor connection	10	AM-IF input
3		11*2	AM mix output
4	GND	12*2	AM mix output
5	FM DET coil connection	13*2	AM bypass capacitor connection
6	VCC	14	AM RF input
7*1	LED drive terminal (TUNED)	15	Regulator output
8	FM DET output	16	AM OSC connection

- *1: Active low.
- *2: TUNED IND cannot be driven when the voltage of this pin becomes less than 0.9V. Accordingly, LED does not light up.
- *3: Pin (12) is turned to FM when it is opened. When the electric potential of pin (12) is made the same as pin (6) by direct current, the AM circuit is switched ON by the internal switch.
- *4: Pin (13) is turned to AM when it is opened. When pin (13) is grounded, the FM circuit is switched ON by the internal switch and AM circuit is switched OFF. At this time, pin (12) is connected in the same electric potential with pin (6).

• IC (AN7470P) PIN DESCRIPTION

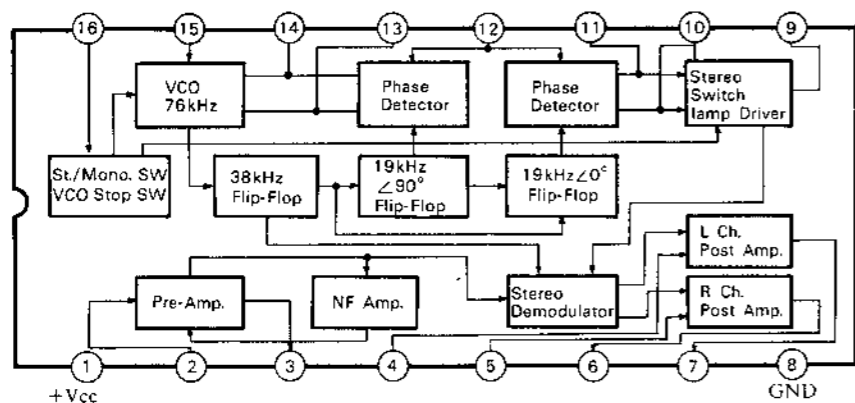

Fig. 6-2 AN7470P Block diagram

Pin No.	Pin Name	Pin No.	Pin Name
1	VCC	9*1	Stereo Indicator and VCO Freq. Monitor
2	Composite Sig. Input	10, 11	Pilot Det. Low-pass Filter
3	Buffer Amp. Output	12	Pilot Signal Input
4	L Ch. Amp. Feedback	13	PLL Low-pass Filter
5	R Ch. Amp. Feedback	14	PLL Low-pass Filter
6	R Ch. Amp. Output	15	VCO RC Time Const
7	L Ch. Amp. Output	16*2	Forced Mono. VCO Killer
8	GND		

- *1: Active low.
- *2: VMO: ST-MONO switching voltage
VVCO: VCO stop voltage

- ① STEREO-MONO automatic switching
- ② Compulsory MONO
- ③ VCO stop

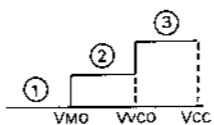
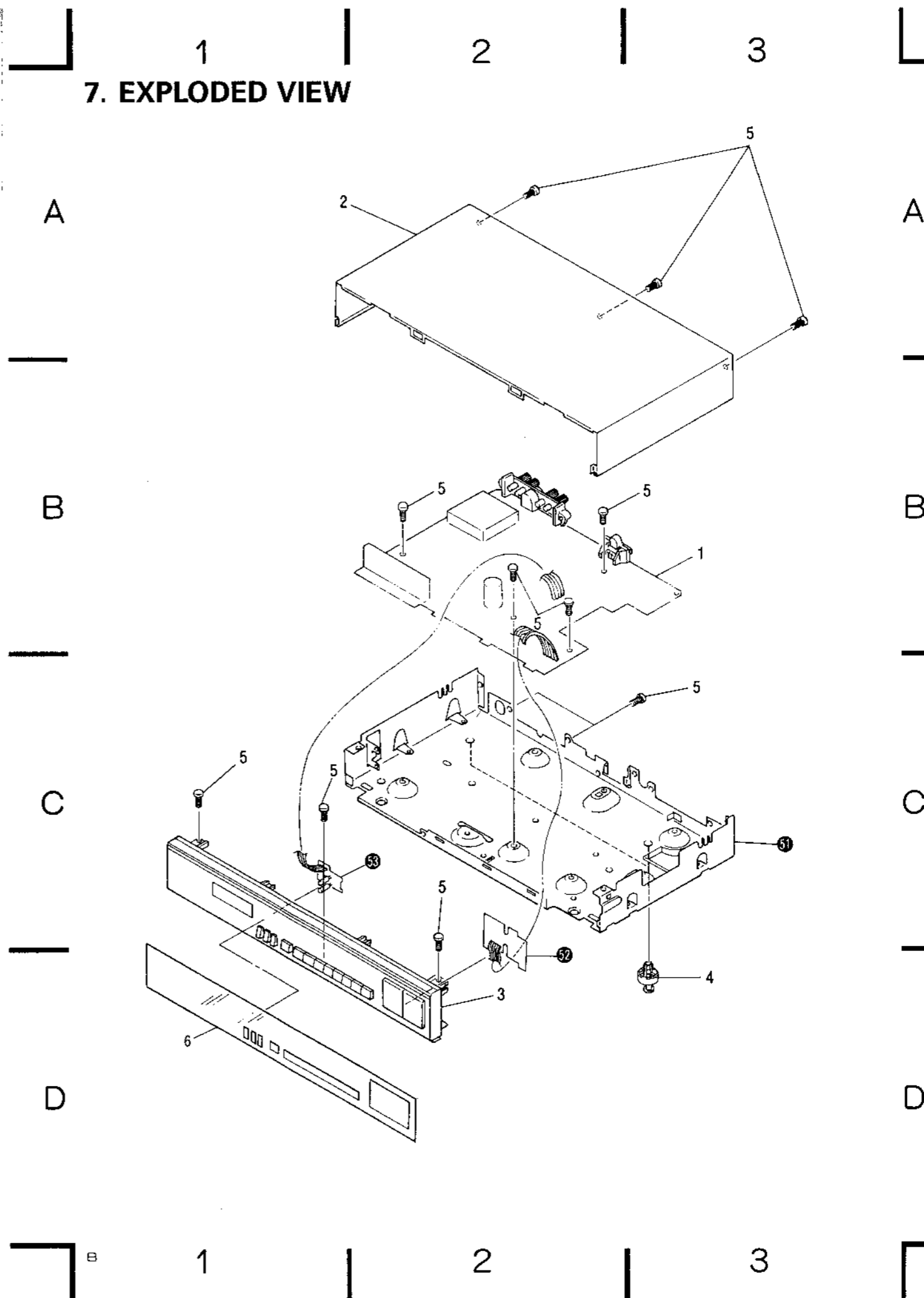

Fig. (a) Input applied to pin (16) of AN7470P

7. EXPLODED VIEW



NOTES:

- Parts without part number cannot be supplied.
- The Δ mark found on some component parts indicates the importance of the safety factor of the part. Therefore, when replacing, be sure to use parts of identical designation.
- For your parts Stock Control, the fast moving items are indicated with the marks **★★** and **★**.
★★ GENERALLY MOVES FASTER THAN ★
 This classification shall be adjusted by each distributor because it depends on model number, temperature, humidity, etc.
- Parts marked by "●" are not always kept in stock. Their delivery time may be longer than usual or they may be unavailable.

Parts List of Exploded View

Mark	No.	Part No.	Description	Mark	No.	Part No.	Description
	1.	GWE-270	Tuner assembly		51.		Chassis
	2.	ANE1003	Bonnet case (BLACK)		52.		Switch assembly
		ANE1026	Bonnet case (SILVER)		53.		LED assembly
	3.	AMB1002	Front panel (BLACK)				
		AMB1036	Front panel (SILVER)				
	4.	AMR1002	Leg assembly				
	5.	BBZ30P080FZK	Screw				
	6.	AAK1009	PVC panel (BLACK)				
		AAK1052	PVC panel (SILVER)				

8. PACKING

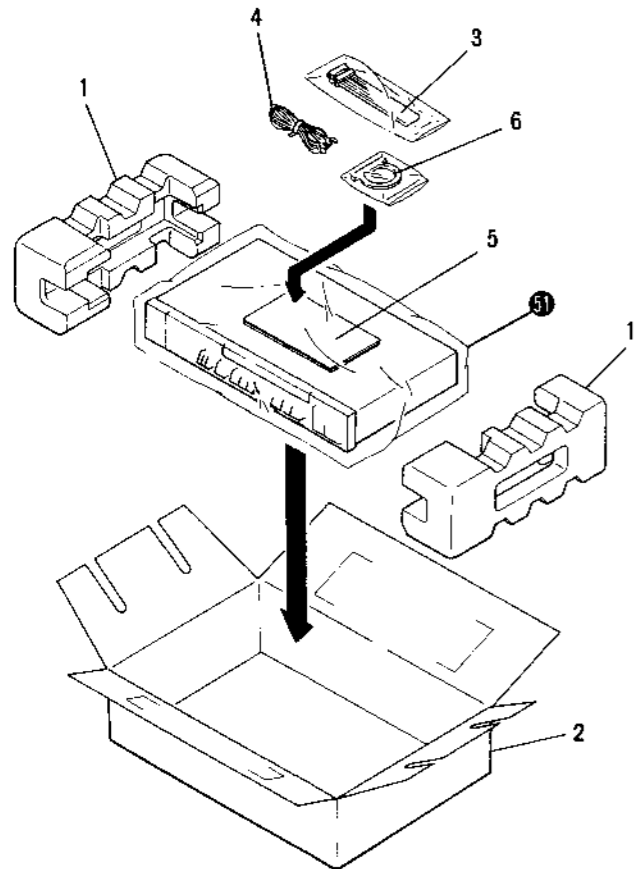

Parts List

Mark	No.	Part No.	Description
	1.	AHA-376	Side pad
	2.	AHD1008	Packing case (BLACK)
		AHD1043	Packing case (SILVER)
	3.	ADE-088	Connection cord
	4.	ADH-005	FM antenna
	5.	ARH-051	Supplementary instructions
	6.	ATB-102	Loop antenna assembly
	51.		Vinyl sheet

External Appearance of Transistors and ICs

AN7470P
AN7470
LA1260

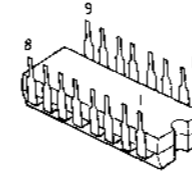

TC9157AP

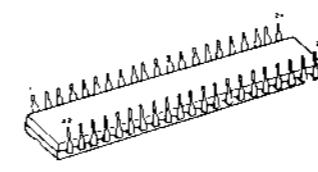

TD6104P

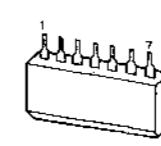

TD6301 AP

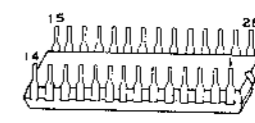

2SA933S
2SC1740S
2SC2668

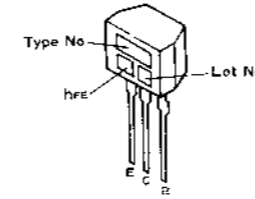

2SK161-Y
2SK241-Y

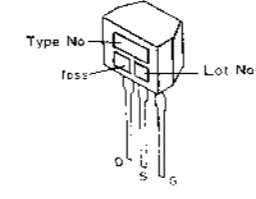

2SC2786-L

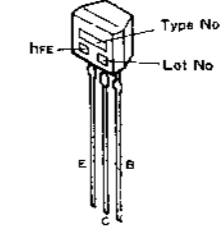

9. P. C. BOARDS CONNECTION DIAGRAM

A

B

C

D

A

B

C

D

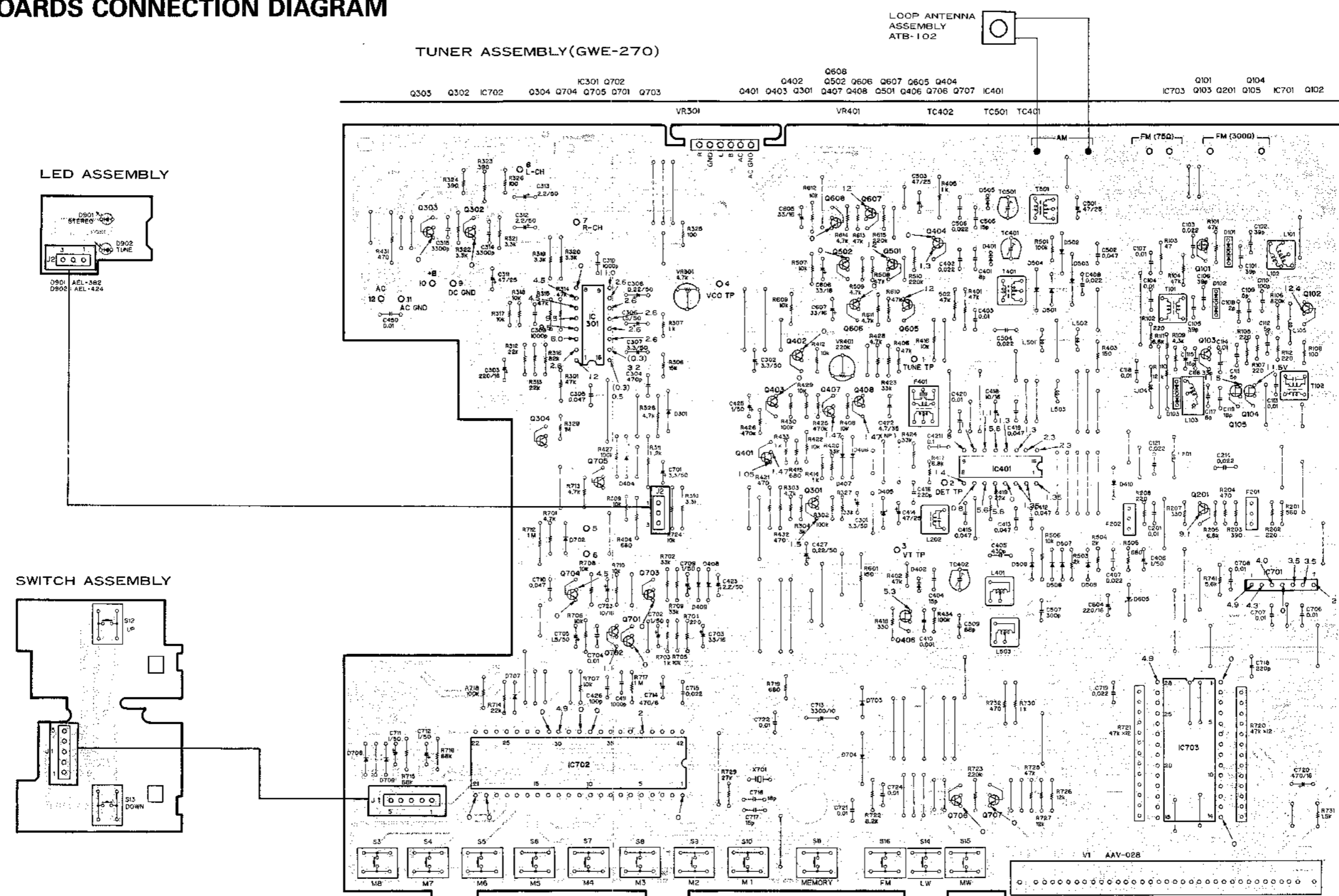

IC301: AN7470P (AN7470) IC401: LA12609 IC701: TC6104P IC702: TC9157AP IC703: TD6301AP Q101: 2SK241 Q102: 2SC2786 Q103, 201: 2SC2668 Q104, 105, 406: 2SK161 (2SK241) Q301~303, 401~404, 502, 606, 608, 701~707: 2SC17405
 Q304, 407, 408, 501, 605, 607: 2SA933S
 D101~103: 1SV1M7 D301, 404, 406~410, 501, 502, 507, 509, 702~704, 707~709: 1SS131 (1S1035) Q401, 402, 505: SVC321C3/D3 D405, 605: RD5.6EB (HZ5.6EB) D503, 504, 506, 508: MA859

11. ELECTRICAL PARTS LIST

NOTES:

- When ordering resistors, first convert resistance values into code form as shown in the following examples.
 - Ex. 1 When there are 2 effective digits (any digit apart from 0), such as 560 ohm and 47k ohm (tolerance is shown by J = 5%, and K = 10%).

560Ω	56 × 10 ¹	561.....	RD1/4PS	□	□	J
47kΩ	47 × 10 ³	473.....	RD1/4PS	□	□	J
0.5Ω	0R5.....		RN2H	□	□	K
1Ω	010.....		RS1P	□	□	K
 - Ex. 2 When there are 3 effective digits (such as in high precision metal film resistors).

5.62kΩ	562 × 10 ¹	5621.....	RN1/4SR	□	□	□	F
--------	-----------------------	-----------	---------	---	---	---	---
- The Δ mark found on some component parts indicates the importance of the safety factor of the part. Therefore, when replacing, be sure to use parts of identical designation.
- For your parts Stock Control, the fast moving items are indicated with the marks **★★** and **★**.
 - ★★** **GENERALLY MOVES FASTER THAN ★**
 - This classification shall be adjusted by each distributor because it depends on model number, temperature, humidity, etc.
- Parts marked by "☉" are not always kept in stock. Their delivery time may be longer than usual or they may be unavailable.

Miscellaneous Parts

Mark	Symbol & Description	Part No.
	Tuner assembly	GWE-270
	Switch assembly	Non supply
	LED assembly	Non supply

Tuner assembly (GWE-270)

SEMICONDUCTORS

Mark	Symbol & Description	Part No.
★★	IC301	AN7470P (AN7470)
★★	IC401	LA1260
★★	IC702	TC9157AP
★★	IC701	TD6104P
★★	IC703	TD6301AP
★★	Q304, Q407, Q408, Q501, Q605, Q607	2SA933S
★★	Q301 - Q303, Q401 - Q404, Q502, Q606, Q608, Q701 - Q707	2SC1740S
★★	Q102	2SC2786-L
★★	Q103, Q201	2SC2668
★★	Q104, Q105, Q406	2SK161-Y (2SK241-Y)
★	Q101	2SK241-Y
★	D503, D504, D506, D508	MA859
★	D405, D605	RD5.6EB (HZ5.6EB)
★	D401, D402, D505	SVC321C3/D3
★	D301, D404, D406 - D410, D501, D502, D507, D509, D702 - D704, D707 - D709	1SS131 (US1035)
★	D101 - D103	1SV147

SWITCHES

Mark	Symbol & Description	Part No.
★★	S3 - S11, S14 - S16 Tact switch (FUNCTION, MEMORY, STATION CALL)	ASG-711 (ASG 703)

COILS, TRANSFORMERS, AND FILTERS

Mark	Symbol & Description	Part No.
	L401 AM OSC coil	ATB-100
	L101 FM ANT coil	ATC-192
	L102 FM ANT coil	ATC-193
	L103 FM OSC coil	ATC-214
	L503 LW OSC coil	ATD-023
	L202 FM DET coil	ATE-072
	L501, L502 Inductor	ATH-108
	L203 Inductor	ATH-116
	L104, L105, L201 Inductor	ATH-049
	T401 AM ANT transformer	ATB-099
	T101 FM RF transformer	ATC-194
	T501 LW ANT transformer	ATD-027
	T102 FM matching transformer	ATE-063
	F202 FM ceramic filter	ATF-107
	F201 FM ceramic filter	ATF-119
	F401 AM ceramic filter	ATF-133

CAPACITORS

Mark	Symbol & Description	Part No.
	C713 (3300/10V) TC401, TC402 Trimmer TC601 Trimmer C716	ACH-389 ACM-015 ACM-020 CCCH180J50 (CCDCH180J50)
	C509	CCCH680J50 (CCDCH680J50)
	C416, C718	CCCSL221J50 (CCDSL221J50)
	C117, C401	CCDCH080D50
	C115, C404, C505, C717 C116 C101, C102, C105, C106 C108 C109, C111, C112	CCDCH150J50 CCDCH330J50 CCDRH390J50 CCDSL020C50 CCDSL050C50
	C110, C426 C119 C422 C308, C427 C406, C425, C702, C709, C711, C712	CCDSL101J50 CCDTH180J50 CEANP4R7M35 CEASR22M50 CEAS010M50L
	C306, C705 C419, C723 C312, C313, C423 C303, C604	CEAS1R5M50 CEAS100M16 CEAS2R2M50 CEAS221M16
	C301, C302, C307, C701 C605 - C607, C703 C311, C414, C501, C503 C720 C714	CEAS3R3M50 CEAS330M16 CEAS470M25 CEAS471M16 CEAS471M6
	C309, C310, C410, C411	CKCYB102K50 (CKDYB102K50)
	C314, C315	CKCYB332K50 (CKDYB332K50)
	C305, C412, C413, C419, C502, C710	CKCYF473Z50 (CKDYF473Z50)
	C415	CKCYX473M25 (CKDYX473M25)
	C104, C107, C113, C114, C118, C201, C403, C420, C450, C704, C706 - C708, C721, C722, C724	CKDYF103Z50
	C103, C121, C214, C402, C407, C408, C504, C506, C715, C719 C421 C507	CKDYF223Z50 CQMA104J50 CQSA301J50
	C405 C304	CQSA431J50 CQSA471J50

RESISTORS

NOTE: When ordering resistors, convert the resistance value into code form, and then rewrite the part no. as before.

Mark	Symbol & Description	Part No.
★	VR401 Semi-fixed (220kΩ)	VRTB6VS224
★	VR301 Semi-fixed (4.7kΩ)	VRTB6VS472
Δ	R601	RS1LMF151J
	R720, R721	RA12S473J
	R404, R405, R421, R431, R432	RD1/4PM□□□J
	Other resistors	RD1/8PM□□□J

OTHERS

Mark	Symbol & Description	Part No.
	Terminal (ANTENNA with connector socket (FM75Ω))	AKA-018
Δ ★	Terminal (AC and DC power supply/output)	AKP-083
★	V1 Fluorescent tube	AAV-028
★	X701 Crystal resonator	ASS-025

Switch Assembly

SWITCHES

Mark	Symbol & Description	Part No.
★★	S12, S13 Tact switch (TUNING+, TUNING-)	ASG-711 (ASG-703)

LED Assembly

SEMICONDUCTORS

Mark	Symbol & Description	Part No.
★	D901 LED	AEL-382
★	D902 LED	AEL-424

12. ADJUSTMENT

FM Tuner Section Adjustment

- Connect up as indicated in Fig. 12-1.
- Press the FM key to set FM mode.

Note: Stereo modulation: Main 1 kHz L+R ± 68.25 Hz dev.
Pilot 19 kHz ± 6.75 kHz dev.

Step No.	FM SG (1kHz ± 75kHz dev.)		F-X55ZL(BK) (F-X55ZL) tuned frequency display	Adjustment	
	Frequency (MHz)	Level (dB)		Adjustment location	Specifications
1	No input signal		87.5 MHz	—	Check pin 3 (3.4V ± 1.5V) of tuner assembly.
2	No input signal		108.0 MHz	—	Check pin (8.7V ± $\frac{2.5}{2.0}$ V) of tuner assembly.
3	98.0	20-30	98.0 MHz	T101, T102	Set the output from pin 1 of the tuner assembly to maximum level. (Before performing the adjustment of Step 3, turn VR401 fully counterclockwise.)
4	98.0	60	98.0 MHz	L202	Set pin 2 of tuner assembly to 1.4V (± 0.01V).
5	98.0	80		VR401	Set pin 1 of tuner assembly to 1.1V (± 0.01V).
6	98.0	0		—	Check pin 1 of tuner assembly below 0.8V.
7	98.0	80	98.0 MHz	VR301	Adjust the frequency at pin 4 of tuner assembly to 76kHz (± 150 Hz).
No modulation					
8	98.0	60	98.0 MHz	T102	Minimize distortion in both left and right channel outputs (adjust T102 to within ± 90°).
Stereo modulation (note)					
9	98.0	Variable	98.0 MHz	Confirm that the TUNED IND and STEREO IND light up when the level of FM SG is turned to high, and that the TUNED IND and STEREO IND light off when the level of the FM SG is turned to low.	
Stereo modulation (note)					

AM (MW) Tuner Section Adjustment

- Connect up as indicated in Fig. 12-2.
- Press the AM (MW) key to set AM (MW) mode.
- Set the AM CHANNEL STEP switch to the 9 kHz position. (F-X55Z(BK)/ZUC, Z model only)

Step No.	AM SG (400Hz, 30% modulation)		F-X55ZL(BK) (F-X55ZL) tuned frequency display	Adjustment	
	Frequency (kHz)	Level (dB)		Adjustment location	Specifications
1	No input signal		531 kHz	L401	Set pin 3 of tuner assembly to 1.3V (± 0.1V).
2	No input signal		1602 kHz	TC402	Set pin 3 of tuner assembly to 10.0V (± 0.3V).
3	Repeat steps 1 and 2 until both specification ratings are satisfied.				
4	603	40	603 kHz	T401	Set the output from pin 1 of the tuner assembly to maximum level.
5	1395	40	1395 kHz	TC401	
6	Repeat steps 4 and 5 until both specification ratings are satisfied.				
7	1395	Variable	1395 kHz	Check that the TUNING indicator comes on when the AM SG level is gradually increased.	

AM (LW) Tuner Section Adjustment (F-X55ZL(BK), F-X55ZL/ZEB model only)

- Connect up as indicated in Fig. 12-2.
- Press the AM (LW) key to set AM (LW) mode.

Step No.	AM SG (400Hz, 30% modulation)		F-X55ZL(BK) (F-X55ZL) tuned frequency display	Adjustment	
	Frequency (kHz)	Level (dB)		Adjustment location	Specifications
1	No input signal		281 kHz	L503	Set pin 3 of tuner assembly to 5.2V (± 0.1V).
2	164	40	164 kHz	T501	Set the output from pin 1 of the tuner assembly to maximum level.
3	254	40	254 kHz	TC401	
4	Repeat steps 2 and 3 until both specification ratings are satisfied.				

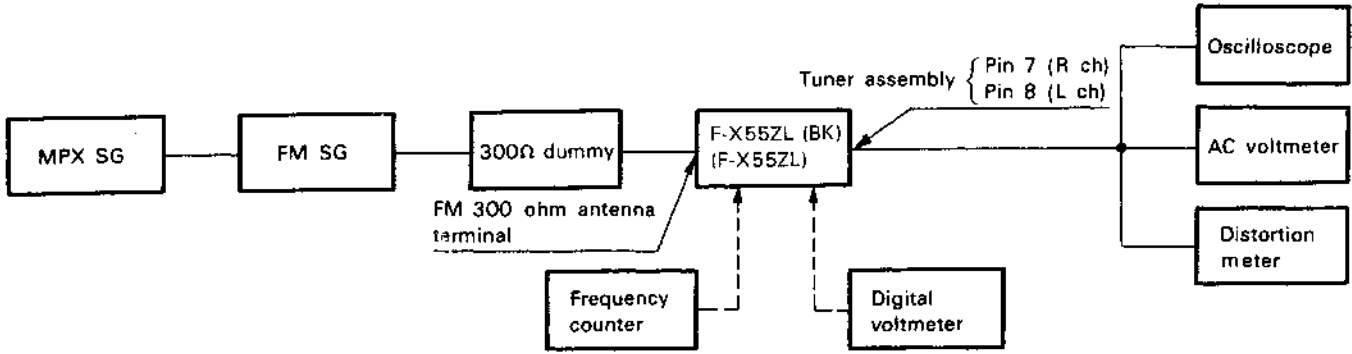

Fig. 12-1 FM adjustment connection diagram

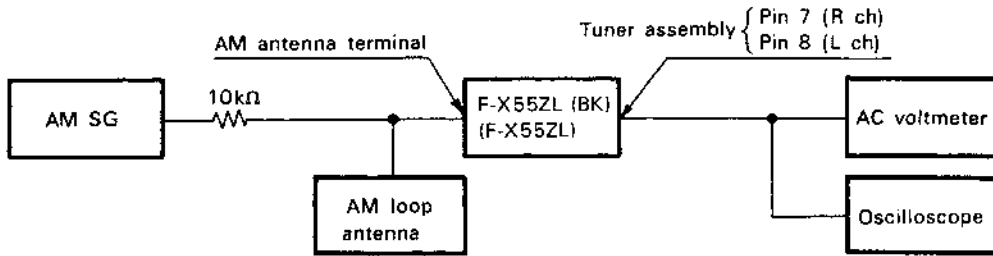

Fig. 12-2 AM adjustments connection diagram

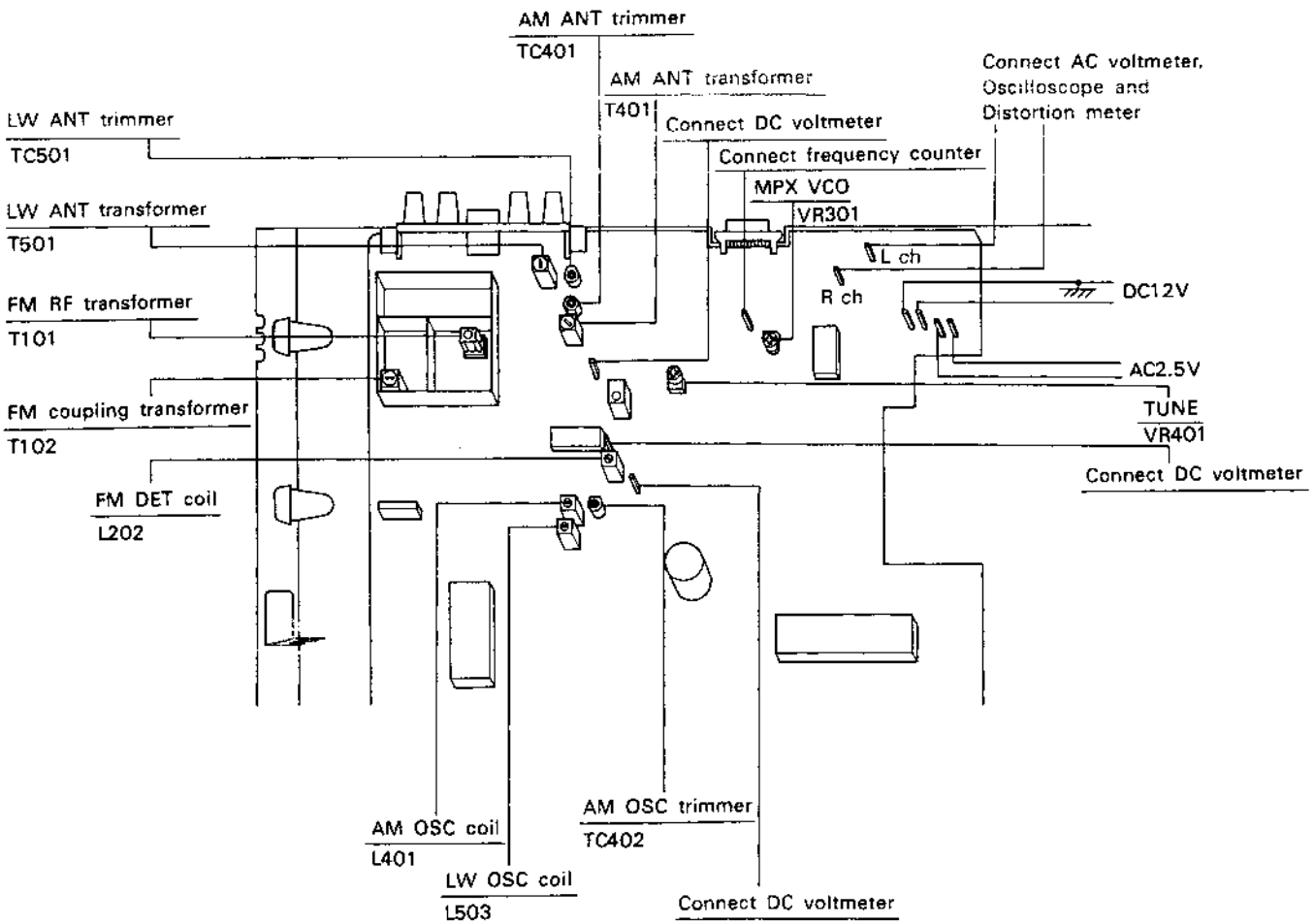

Fig. 12-3 Adjustment positions

12. RÉGLAGE

Réglage de la partie syntoniseur MF

- Faire les raccordements comme indiqué en Fig. 12-1.
- Enfoncer la touche MF pour régler en mode MF.

Note: Modulation stéréo: Principal 1kHz L+R ± 68,25kHz dév.
Pilote 19kHz ± 6,75kHz dév.

Etape N°	FM SG (1kHz ± 75kHz dév.)		Affichage de fréquence syntonisée F-X55ZL(BK) (F-X55ZL)	Réglage	
	Fréquence (MHz)	Niveau (dB)		Lieu de réglage	Caractéristiques
1	Pas de signal d'entrée		87,5 MHz	—	Vérifier la fiche 3 (3,4V ± 1,5V) de l'ensemble syntoniseur.
2	Pas de signal d'entrée		108,0 MHz	—	Vérifier la fiche 3 (8,7V ± 2,5V) de l'ensemble syntoniseur.
3	98,0	20 à 30	98,0 MHz	T101, T102	Régler la puissance de la fiche 1 de l'ensemble syntoniseur au niveau maximal. (Avant d'effectuer le réglage de l'Etape 3, tourner VR401 à fond dans le sens horaire inversé)
4	98,0	60	98,0 MHz	L202	Régler la fiche 2 de l'ensemble syntoniseur à 1,4V (± 0,01V).
5	98,0	80		VR401	Set pin 1 of tuner assembly to 1,1V (± 0,01V).
6	98,0	0		—	Vérifier si la fiche 1 de l'ensemble syntoniseur est endessous de 0,8V.
7	98,0	80	98,0 MHz	VR301	Régler la fréquence de la fiche 4 de l'ensemble syntoniseur à 76 kHz (± 150 Hz).
Pas de modulation					
8	98,0	60	98,0 MHz	T102	Réduire la distorsion dans les sorties des deux canaux droit et gauche (régler T102 à ± 90°).
Modulation stéréo (Note)					
9	98,0	Variable	98,0 MHz	Confirmer que le TUNED IND et le STEREO IND s'allument lorsque le niveau de FM SG est syntonisé trop haut, et que le TUNED IND et STEREO IND sont éteints lorsque le niveau de FM SG est syntonisé trop bas.	
Modulation stéréo (Note)					

Réglage de la partie syntoniseur MA (MW)

- Faire les raccordements comme indiqué en Fig. 12-2.
- Enfoncer la touche MA (MW) pour régler en mode MA (MW).
- Régler le commutateur MA CHANNEL STEP en 9ème position. (F-X55Z(BK)/ZUC, seulement modèle Z)

Etape N°	AM SG (400Hz, 30% modulation)		Affichage de fréquence syntonisée F-X55ZL(BK) (F-X55ZL)	Réglage	
	Fréquence (kHz)	Niveau (dB)		Lieu de réglage	Caractéristiques
1	Pas de signal d'entrée		531 kHz	L401	Régler la fiche 3 de l'ensemble syntoniseur à 1,3V (± 0,1V).
2	Pas de signal d'entrée		1602 kHz	TC402	Régler la fiche 3 de l'ensemble syntoniseur à 10,0V (± 0,3V).
3	Répéter les Etapes 1 et 2 jusqu'à ce que les taux nominaux préconisés soient atteints.				
4	603	40	603 kHz	T401	Régler la puissance de la fiche 1 de l'ensemble syntoniseur au niveau maximal.
5	1395	40	1395 kHz	TC401	
6	Répéter les Etapes 4 et 5 jusqu'à ce que les taux nominaux préconisés soient atteints.				
7	1395	Variable	1395 kHz	Vérifier si l'indicateur TUNING s'allume lorsque le niveau de AM SG augmente graduellement.	

Réglage de la partie syntoniseur MA (LW) (F-X55Z(BK), F-X55ZL/ZEB unique)

- Faire les raccordements comme indiqué en Fig. 12-2.
- Enfoncer la touche MA (LW) pour régler en mode MA (LW).

Etape N°	AM SG (400Hz, 30% modulation)		Affichage de fréquence syntonisée F-X55ZL(BK) (F-X55ZL)	Réglage	
	Fréquence (kHz)	Niveau (dB)		Lieu de réglage	Caractéristiques
1	Pas de signal d'entrée		281 kHz	L503	Régler la fiche 3 de l'ensemble syntoniseur à 5,2V (± 0,1V).
2	164	40	164 kHz	T501	Régler la puissance de la fiche 1 de l'ensemble syntoniseur au niveau maximal.
3	254	40	254 kHz	TC401	
4	Répéter les Etapes 2 et 3 jusqu'à ce que les taux préconisés soient atteints.				

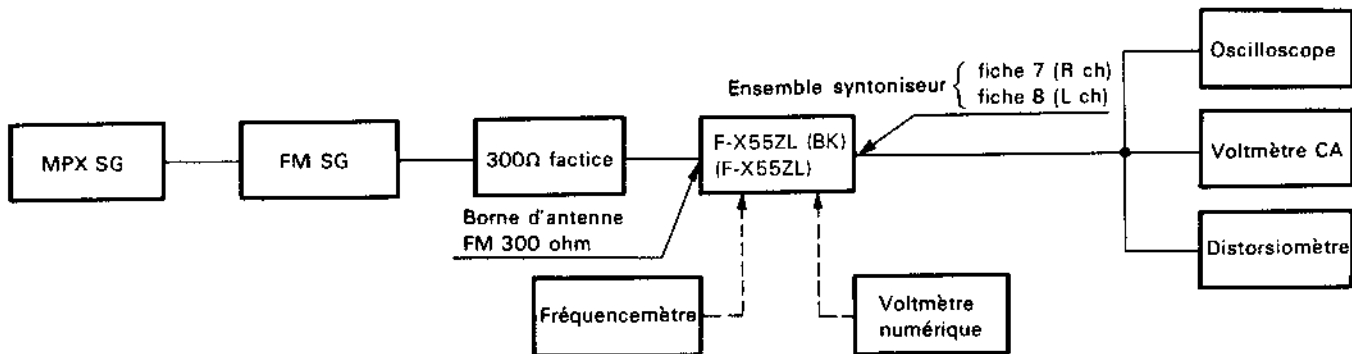

Fig 12-1 Diagramme de raccordement de réglage MF

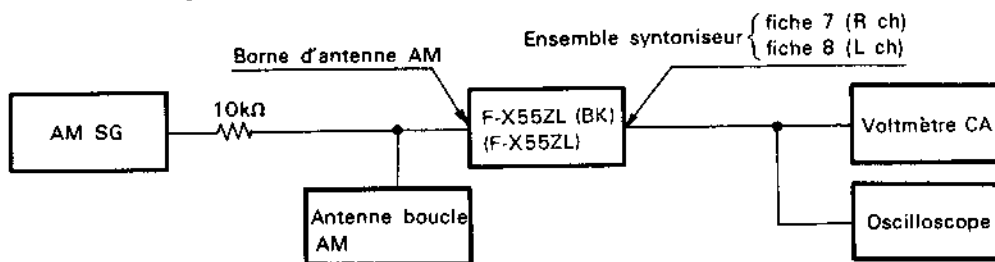

Fig. 12-2 Diagramme de raccordement de réglage MA

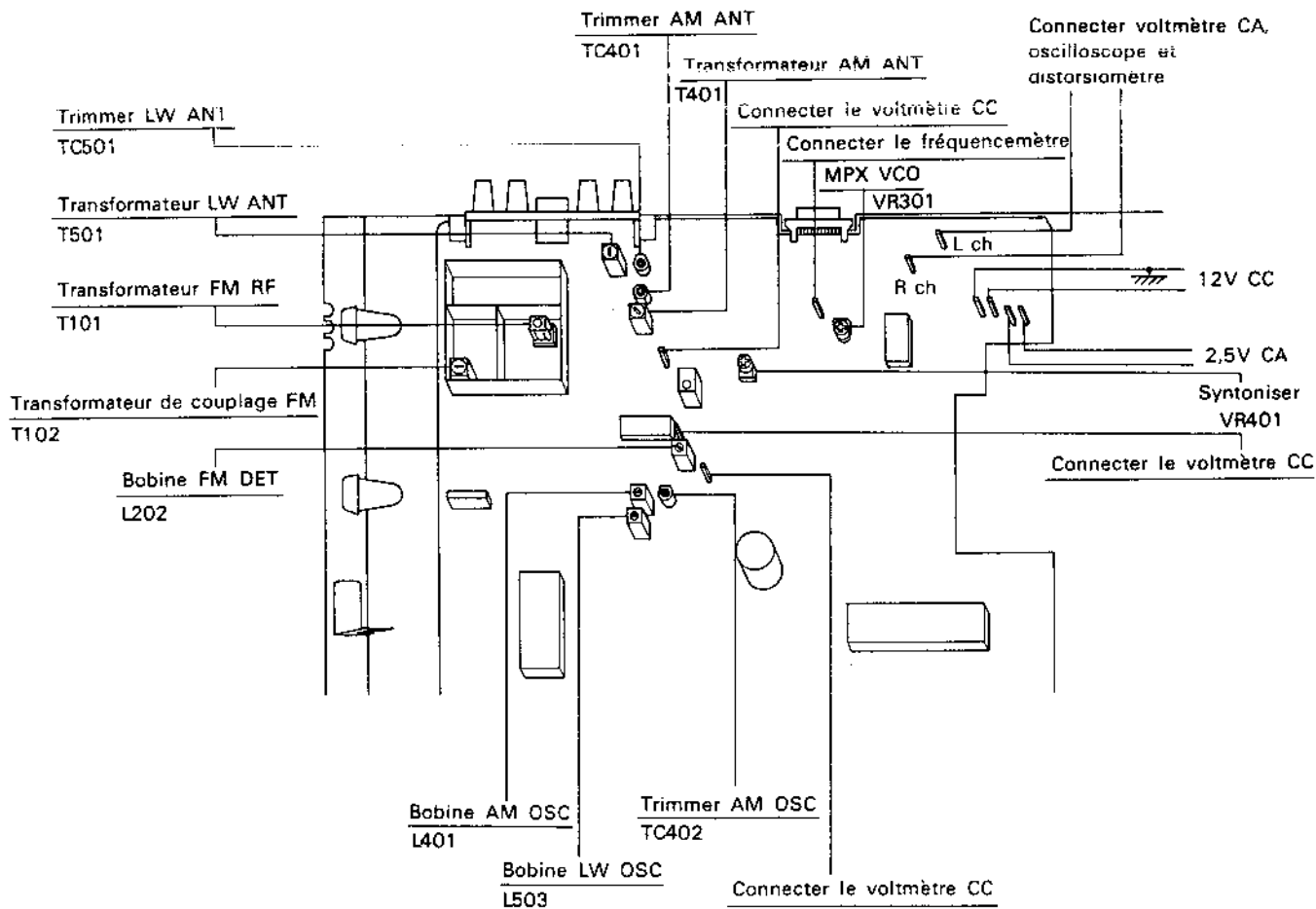

Fig. 12-3 Position de réglage

12. AJUSTE

Ajuste de la sección del sintonizador de FM

- Conecte como es indicado en la Fig. 12-1.
- Oprima la tecla de FM para fijar el modo de FM.

Nota: Modulación estereo: Principal 1 kHz L+R ± 68,25 kHz dev.
Piloto 19 kHz ± 6,75 kHz dev.

No. de paso	FM SG (1kHz ± 75kHz dev.)		Visualización de frecuencia sintonizada F-X55ZL(BK) (F-X55ZL)	Lugar de ajuste	Ajuste
	Frecuencia (MHz)	Nivel (dB)			Especificaciones
1	No hay señal de entrada		87,5 MHz	—	Inspeccione la patilla 3 del conjunto del sintonizador (3,4V ± 1,5V).
2	No hay señal de entrada		108,0 MHz	—	Inspeccione la patilla 3 del conjunto del sintonizador (8,7V ^{+2,5} _{-2,0} V).
3	98,0	20 a 30	98,0 MHz	T101, T102	Fije la salida de la patilla 1 del conjunto del sintonizador al máximo nivel. (Antes de efectuar ajuste del paso 3, gire VR401 completamente en contra del sentido de las manecillas del reloj).
4	98,0	60	98,0 MHz	L202	Fije la patilla 2 del conjunto del sintonizador a 1,4V (± 0,01V).
5	98,0	80		VR401	Fije la patilla 1 del conjunto del sintonizador a 1,1V (± 0,01V).
6	98,0	0		—	Inspeccione la patilla 1 del conjunto del sintonizador que esta abajo de 0,8V.
7	98,0	80	98,0 MHz	VR301	Ajuste la frecuencia en la patilla 4 del conjunto del sintonizador a 76 kHz (± 150 Hz).
Sin modulación					
8	98,0	60	98,0 MHz	T102	Reduzca la distorsión tanto en la salida del canal izquierdo como en la del derecho (ajuste T102 a dentro de ± 90°)
Modulación estereo (Nota)					
9	98,0	Variable	98,0 MHz		Confirme que se enciendan el IND STEREO y el IND TUNED cuando el nivel de FM SG es girado a alto, y que los anteriores IND STEREO y IND TUNED se apaguen cuando el nivel de FM SG es girado a bajo.
	Modulación estereo (Nota)				

Ajuste de la sección del sintonizador de AM (MW)

- Conecte como es indicado en la Fig. 12-2.
- Oprima la tecla AM (MW) para fijar el modo AM (MW).
- Fije el interruptor de AM CHANNEL STEP (paso de canal de AM) a la posición de 9 kHz. (F-X55Z(BK)/ZUC, sólo el modo Z)

No. de paso	AM SG (400Hz, 30% modulation)		Visualización de frecuencia sintonizada F-X55ZL(BK) (F-X55ZL)	Lugar de ajuste	Ajuste
	Frecuencia (kHz)	Nivel (dB)			Especificaciones
1	No hay señal de entrada		531 kHz	L401	Fije la patilla 3 del conjunto del sintonizador a 1,3V (± 0,1V).
2	No hay señal de entrada		1602 kHz	TC402	Fije la patilla 3 del conjunto del sintonizador a 10,0V (± 0,3V).
3	Repita los pasos 1 y 2 hasta que ambos valores nominales especificados sean satisfechos.				
4	603	40	603 kHz	T401	Fije la salida de la patilla 1 del conjunto del sintonizador al máximo nivel.
5	1395	40	1395 kHz	TC401	
6	Repita los pasos 4 y 5 hasta que ambos valores nominales especificados sean satisfechos.				
7	1395	Variable	1395 kHz		Inspeccione que el indicador de TUNING (sintonización) se encienda cuando se aumenta gradualmente el nivel de AM SG.

Ajuste de la sección del sintonizador de AM (LW). (F-X55ZL(BK), F-X55ZL/ZEB sólo)

- Conecte como es indicado en la Fig. 12-2.
- Oprima la tecla AM (LW) para fijar el modo AM (LW).

No. de paso	AM SG (400Hz, 30% modulation)		Visualización de frecuencia sintonizada F-X55ZL(BK) (F-X55ZL)	Lugar de ajuste	Ajuste
	Frecuencia (kHz)	Nivel (dB)			Especificaciones
1	No hay señal de entrada		281 kHz	L503	Fije la patilla 3 del conjunto del sintonizador a 5,2V (± 0,1V).
2	164	40	164 kHz	T501	Fije la salida de la patilla 1 del conjunto del sintonizador al máximo nivel.
3	254	40	254 kHz	TC401	
4	Repita los pasos 2 y 3 hasta que ambos valores nominales especificados sean satisfechos.				

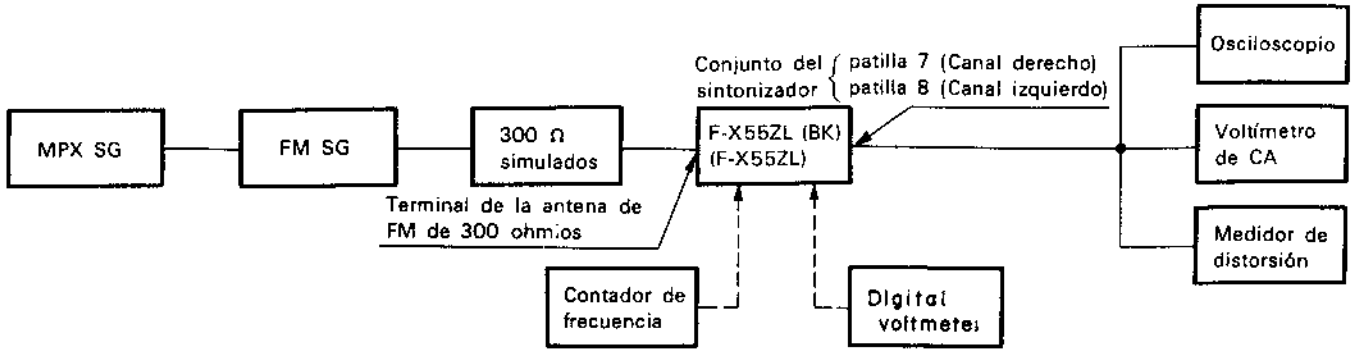

Fig. 12-1 Diagrama de conexión de ajuste de FM

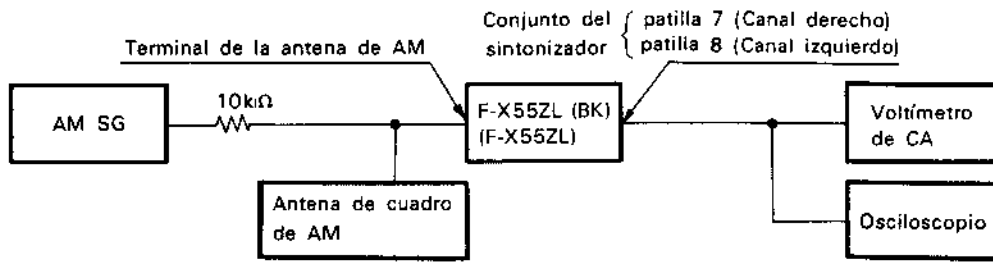

Fig. 12-2 Diagrama de conexión de ajuste de AM

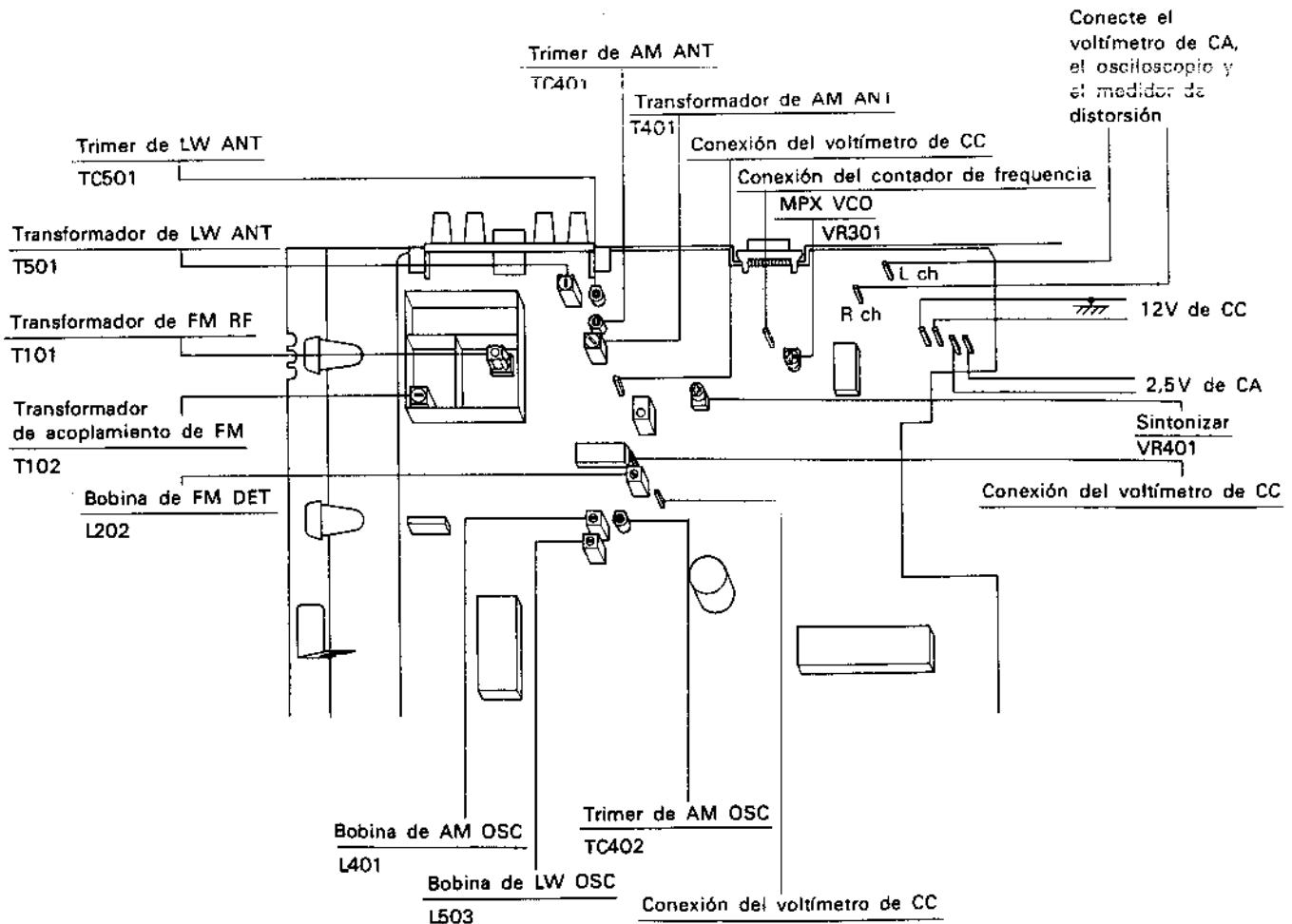

Fig. 12-3 Puntos de ajuste