

SERVICE MANUAL

CS-M01

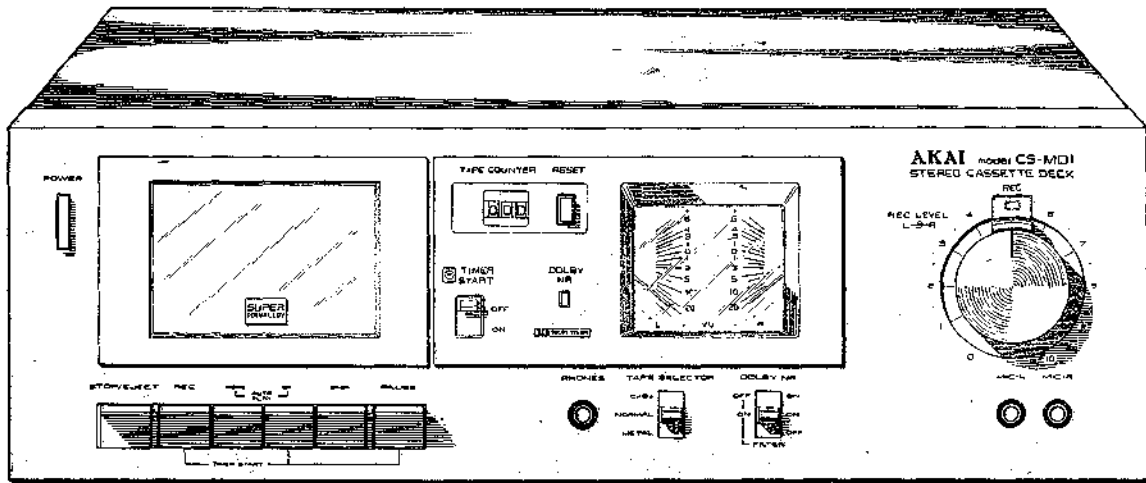

STEREO CASSETTE DECK

MODEL **CS-M01**

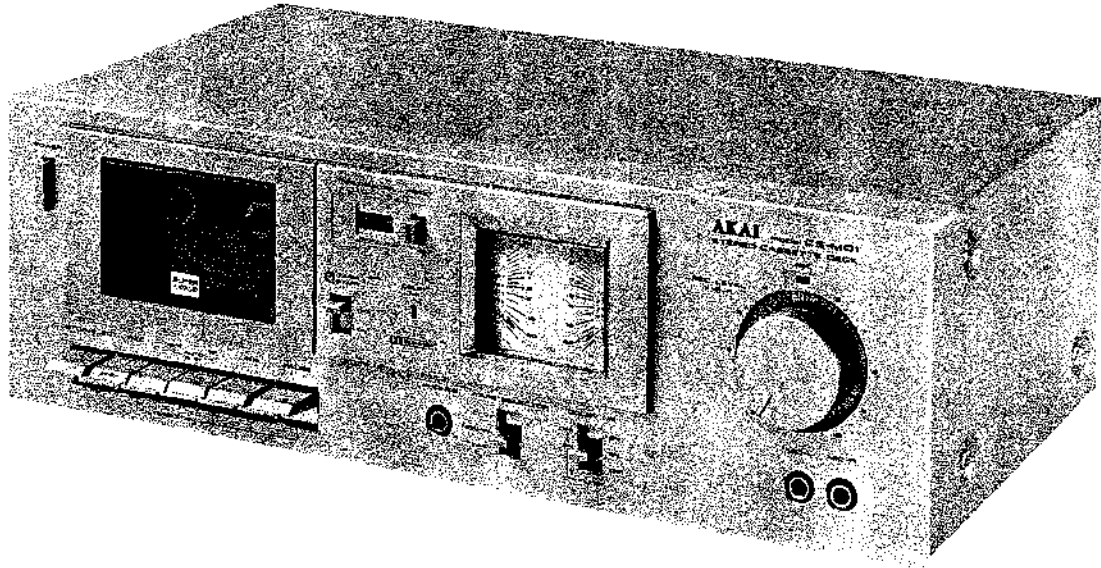

STEREO CASSETTE DECK

MODEL **CS-M01**

ALSO APPLICABLE TO BLACK PANEL MODEL

SECTION 1	SERVICE MANUAL	3
SECTION 2	PARTS LIST	25
SECTION 3	SCHEMATIC DIAGRAM	39

SECTION 1

SERVICE MANUAL

TABLE OF CONTENTS

I. TECHNICAL DATA	4
II. DISMANTLING OF UNIT	5
III. CONTROLS	6
IV. PRINCIPAL PARTS LOCATION	7
V. VOLTAGE AND CYCLE CONVERSION	8
1. VOLTAGE CONVERSION	8
2. CYCLE CONVERSION	8
VI. TIMER START SWITCH OPERATION	9
VII. AUTO STOP MECHANISM OPERATION	10
VIII. MECHANISM ADJUSTMENT	12
IX. HEAD ADJUSTMENT	14
X. AMPLIFIER ADJUSTMENT	15
XI. DC RESISTANCE OF HEADS	18
XII. CLASSIFICATION OF VARIOUS P.C BOARDS	18
1. P.C BOARD TITLES AND IDENTIFICATION NUMBERS	18
2. COMPOSITION OF VARIOUS P.C BOARDS	19

For basic adjustments, measuring methods, and operating principles, refer to **GENERAL TECHNICAL MANUAL**.

I. TECHNICAL DATA

TRACK SYSTEM	4 track 2 channel stereo system
TAPE	Philips type cassette
TAPE SPEED	4.76 cm/s \pm 2.0% (1-7/8 ips. \pm 2.0%)
HEADS	Erase head \times 1 Permalloy head for record/playback \times 1
MOTOR	Electronically speed controlled DC motor \times 1
WOW & FLUTTER	Less than 0.05% WRMS, 0.15% (DIN 45500)
TAPE WINDING TIME	90 sec. using a C-60 cassette tape
FREQUENCY RESPONSE	Normal: 30 to 14,000 Hz \pm 3 dB (-20 VU) CrO ₂ : 30 to 16,000 Hz \pm 3 dB (-20 VU) FeCr: 30 to 17,000 Hz \pm 3 dB (-20 VU)
SIGNAL TO NOISE RATIO	Normal: Better than 55 dB CrO ₂ : Better than 57 dB FeCr: Better than 57 dB (measured via tape with peak recording level) Dolby NR switch ON: Improves up to 10 dB above 5 kHz
HARMONIC DISTORTION	Normal: Less than 0.8% CrO ₂ : Less than 0.7% FeCr: Less than 0.7%
INPUT	MIC: 0.25 mV (input impedance 5 kohms) Required microphone impedance: 600 ohms Line: 70 mV (input impedance 47 kohms)
OUTPUT	Line: 410 mV at 0 VU Required load impedance: more than 20 kohms Phone: 45 mV/8 ohms at 0 VU
DIN	Input: 0.25 mV (input impedance 2.2 kohms) Output: 410 mV (Required load impedance: more than 20 kohms)
DIMENSIONS	440 (W) \times 143 (H) \times 250 (D) mm (17.3 \times 5.6 \times 9.8")
WEIGHT	5.0 kg (11.0 lbs)
POWER CONSUMPTION	U/T, CSA, AAL 10 W
POWER REQUIREMENTS	120V 60 Hz for U.S.A. & Canada 220V 50 Hz for European countries except U.K. 240V 50 Hz for U.K. & Australia 110/120/220/240V switchable 50/60 Hz for other countries

* For improvement purpose, specifications and design are subject to change without notice.

* "Dolby" and the Double D symbol are trademarks of Dolby Laboratories.
(Manufactured under license from Dolby Laboratories).

III. CONTROLS

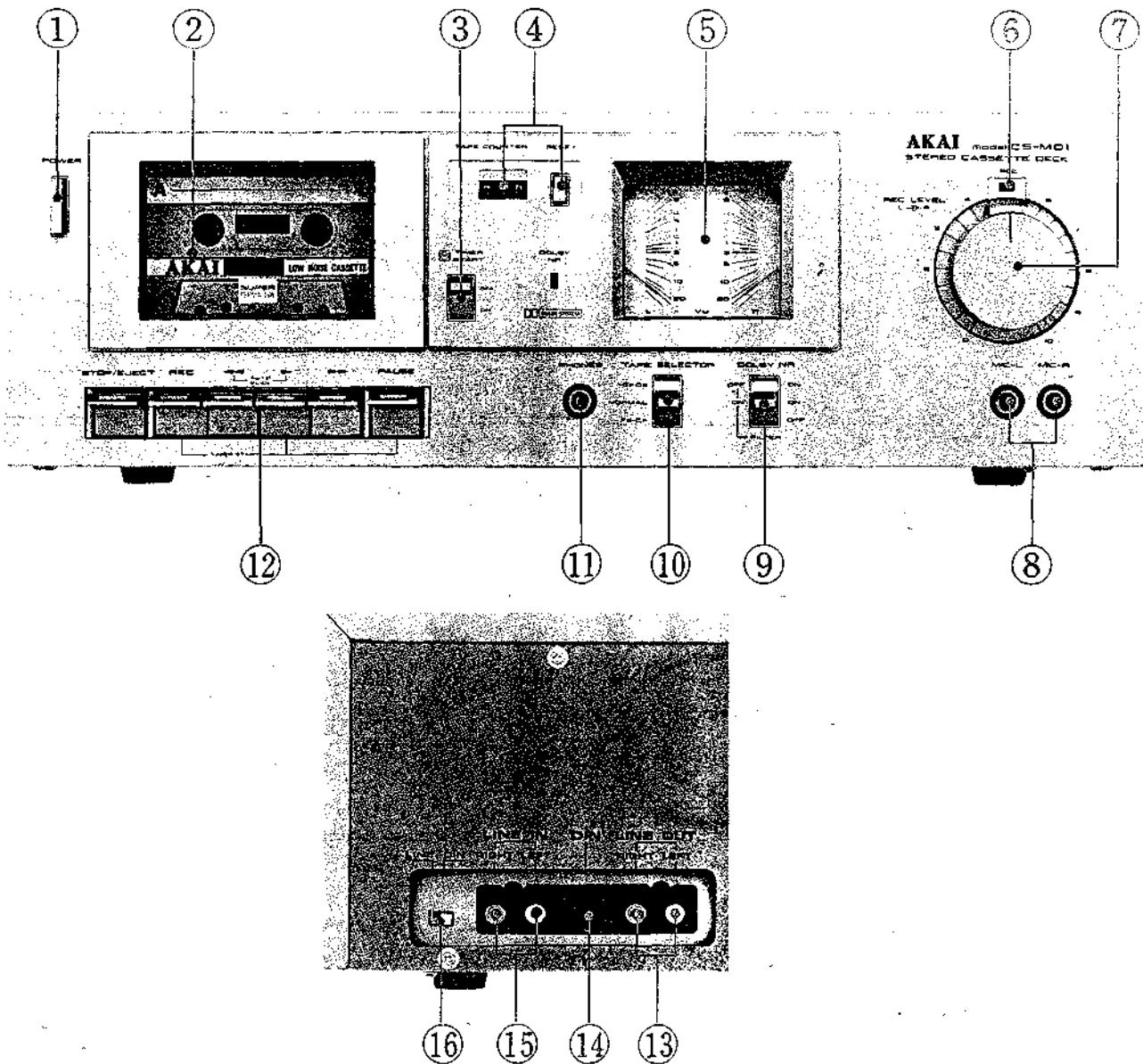
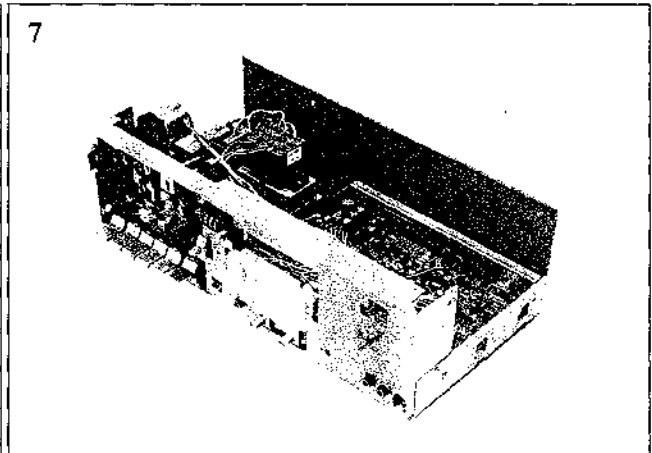
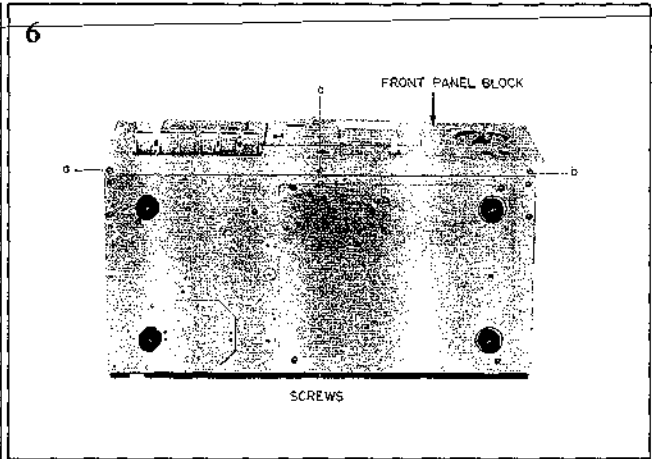
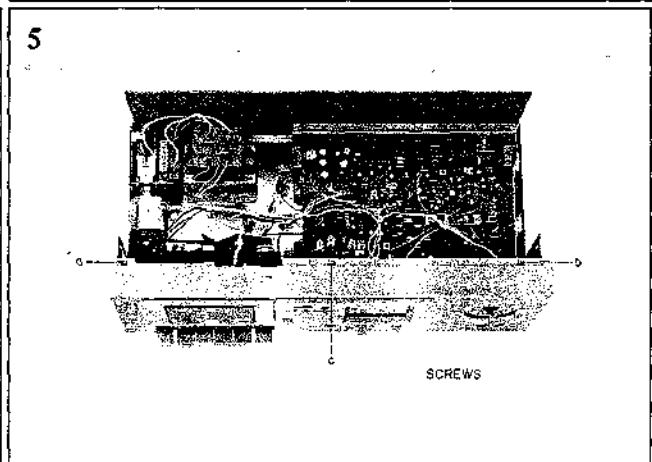
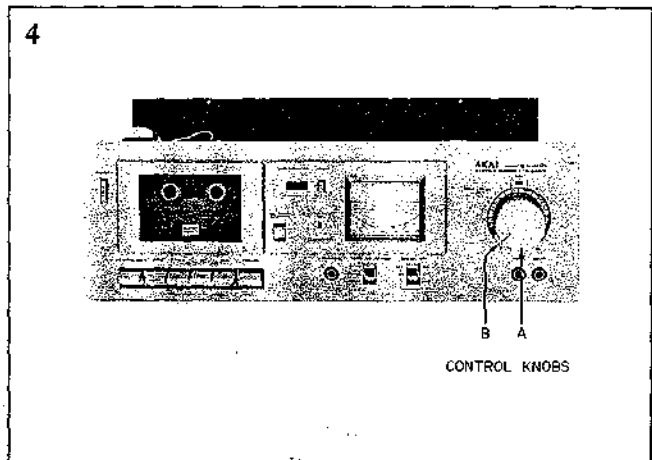
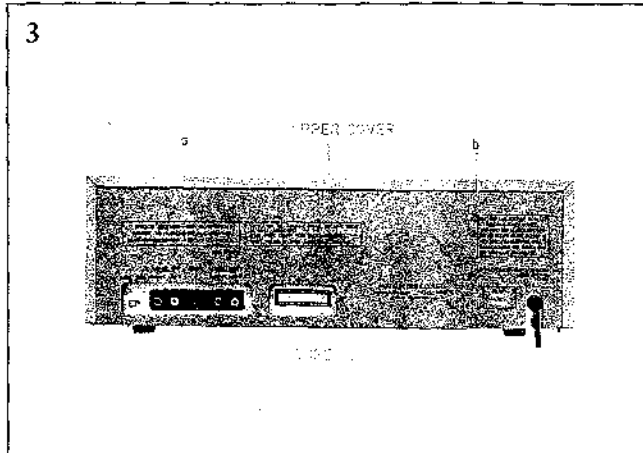
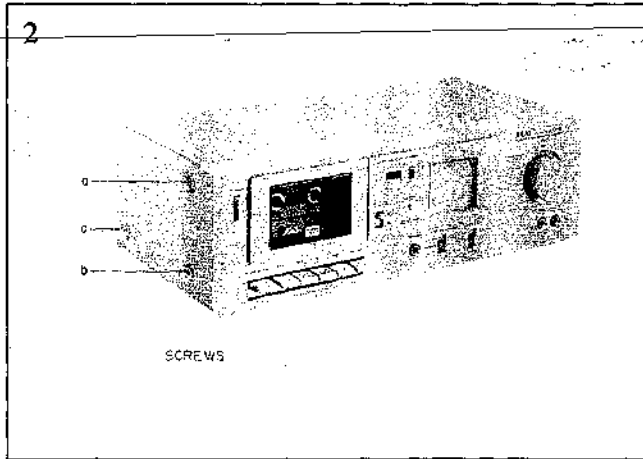
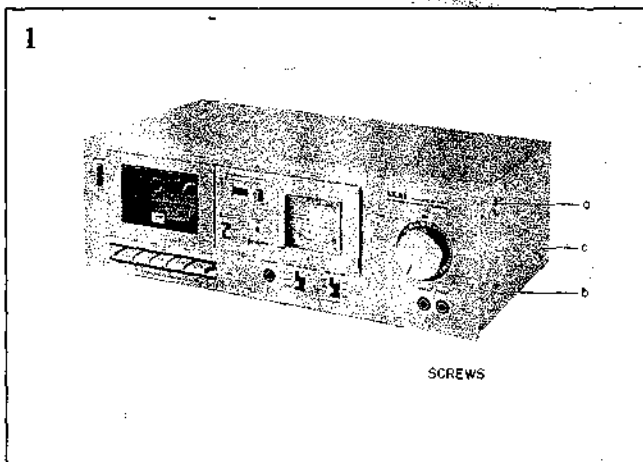

Fig. 1 Controls

- | | |
|---|--|
| 1. POWER SWITCH | 10. TAPE SELECTOR |
| 2. CASSETTE RECEPTACLE | 11. HEADPHONE JACK |
| 3. TIMER START SWITCH | 12. OPERATING KEYS |
| 4. INDEX COUNTER AND RESET BUTTON | 13. LINE OUTPUT JACKS (left and right) |
| 5. VU METERS | 14. DIN JACK (the AAL model does not have this facility) |
| 6. RECORDING INDICATOR LAMP | 15. LINE INPUT JACKS (left and right) |
| 7. LEFT →- RIGHT RECORDING LEVEL CONTROLS | 16. INPUT SELECTOR SWITCH |
| 8. MICROPHONE JACKS (left and right) | (the AAL model does not have this facility) |
| 9. DOLBY NR SWITCH AND MPX FILTER | |

II. DISMANTLING OF UNIT

In case of trouble, etc. necessitating dismantling, please dismantle in the order shown in the photographs. Reassemble in reverse order.



V. VOLTAGE AND CYCLE CONVERSION

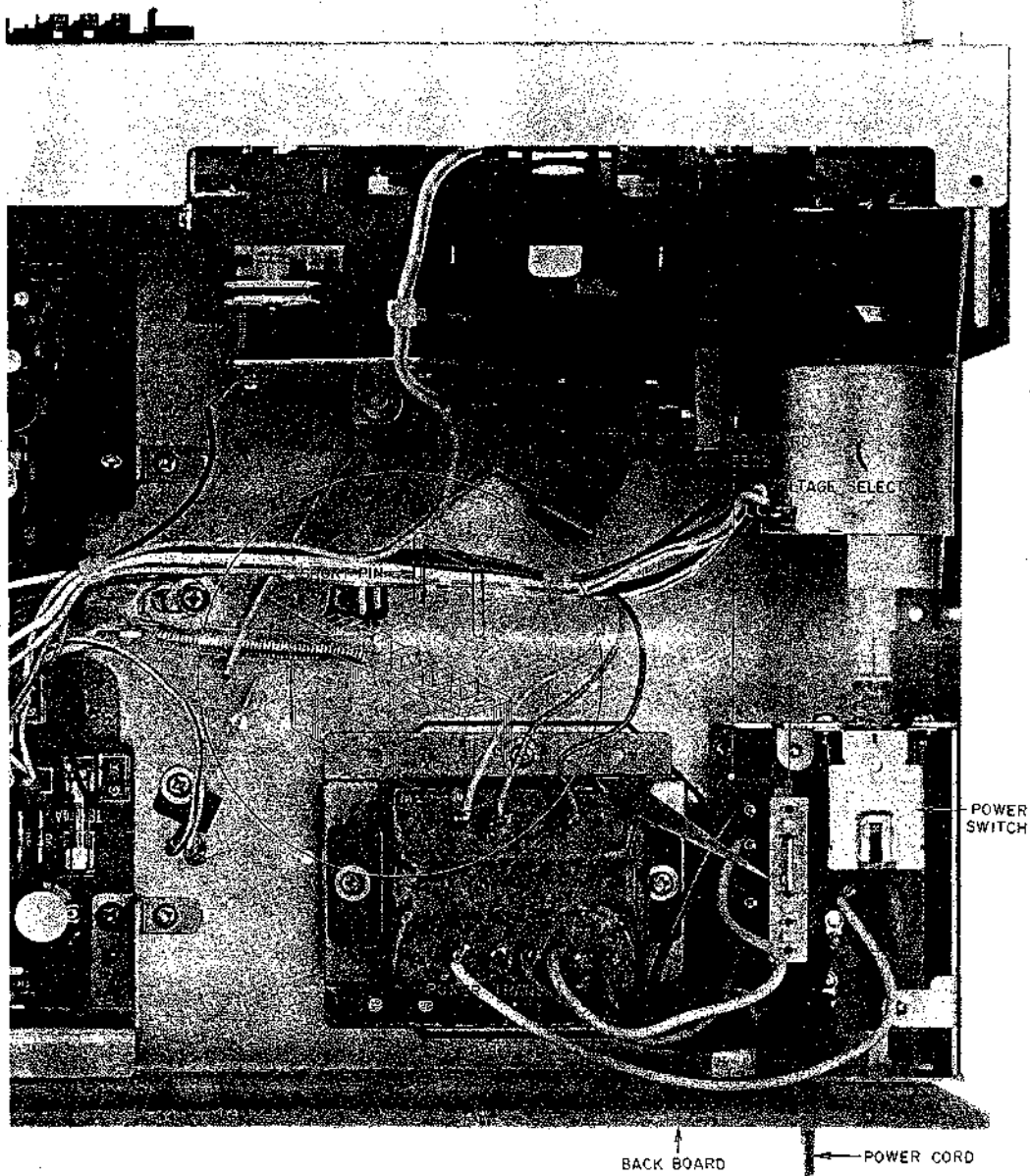

Fig. 4 Voltage Conversion (U/T Model)

1. VOLTAGE CONVERSION

Models for Canada, Europe, USA, UK, and Australia are not equipped with this facility.

Each machine is preset at the factory according to destination, but some machines can be set to 110V, 120V, 220V, or 240V as required. If voltage change is necessary, this can be accomplished as follows:

1. Disconnect power cord.

2. Loosen holding screws and remove upper cover.

3. Remove short pin plug from present holes and replace in correct holes. Follow the markings explicitly.

2. CYCLE CONVERSION

With DC motor, cycle conversion is not necessary.

IV. PRINCIPAL PARTS LOCATION

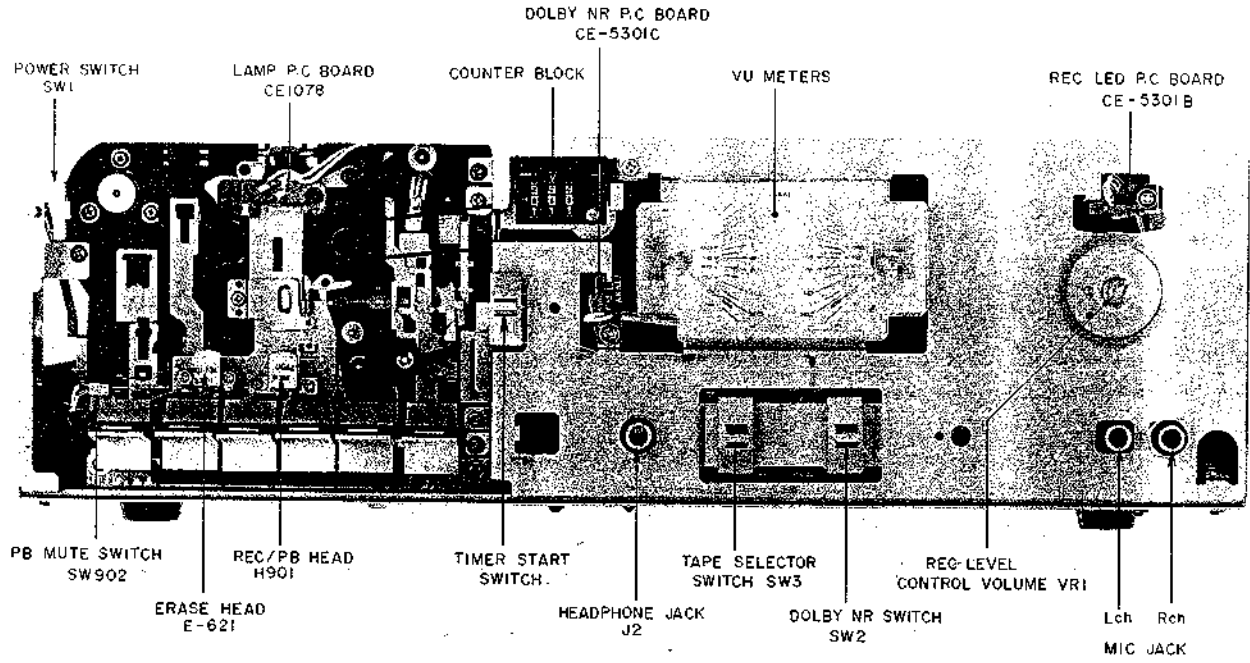

Fig. 2 Front View

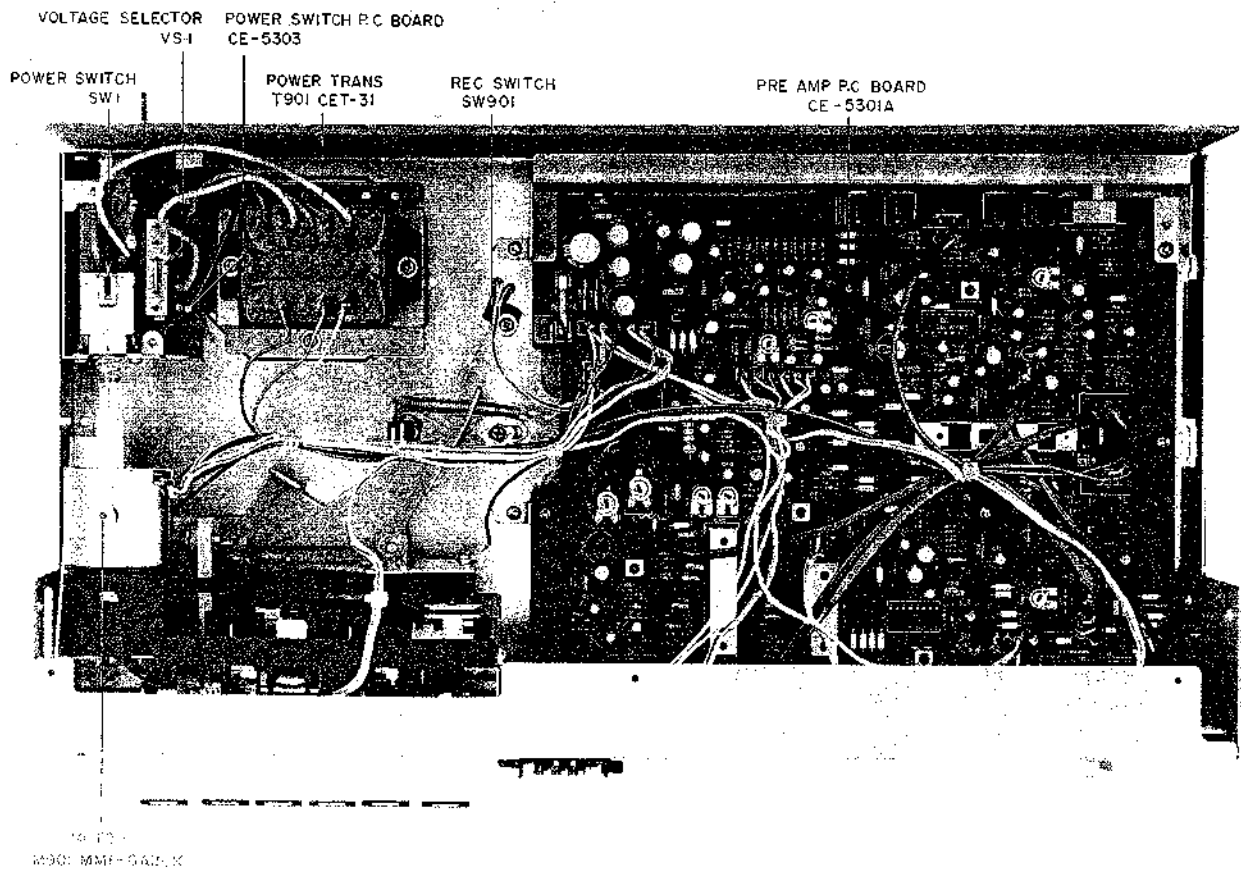

Fig. 3 Top View

VII. AUTO STOP MECHANISM OPERATION

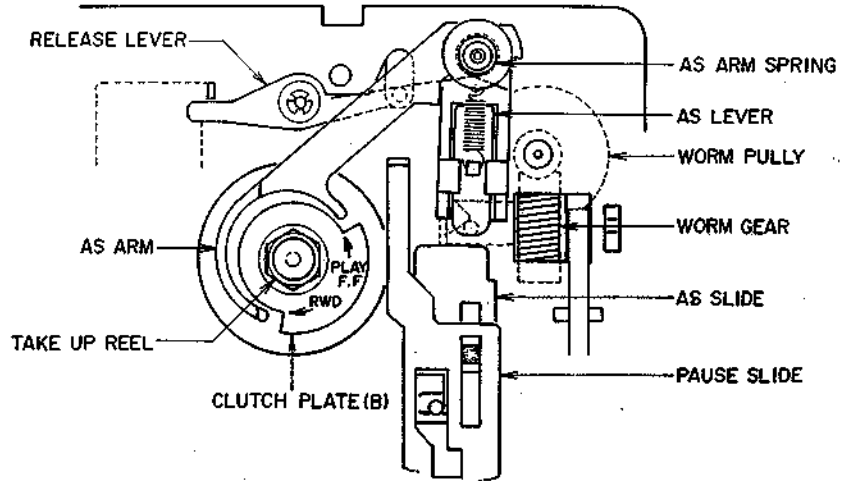

Fig. 6

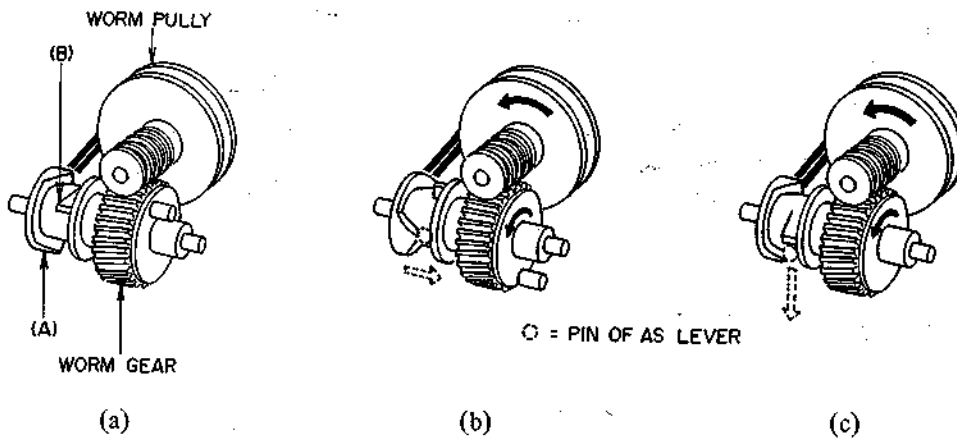

Fig. 7

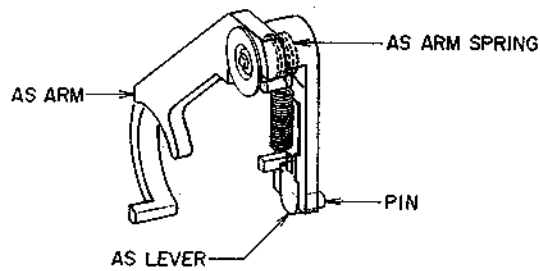

Fig. 8

VI. TIMER START SWITCH OPERATION

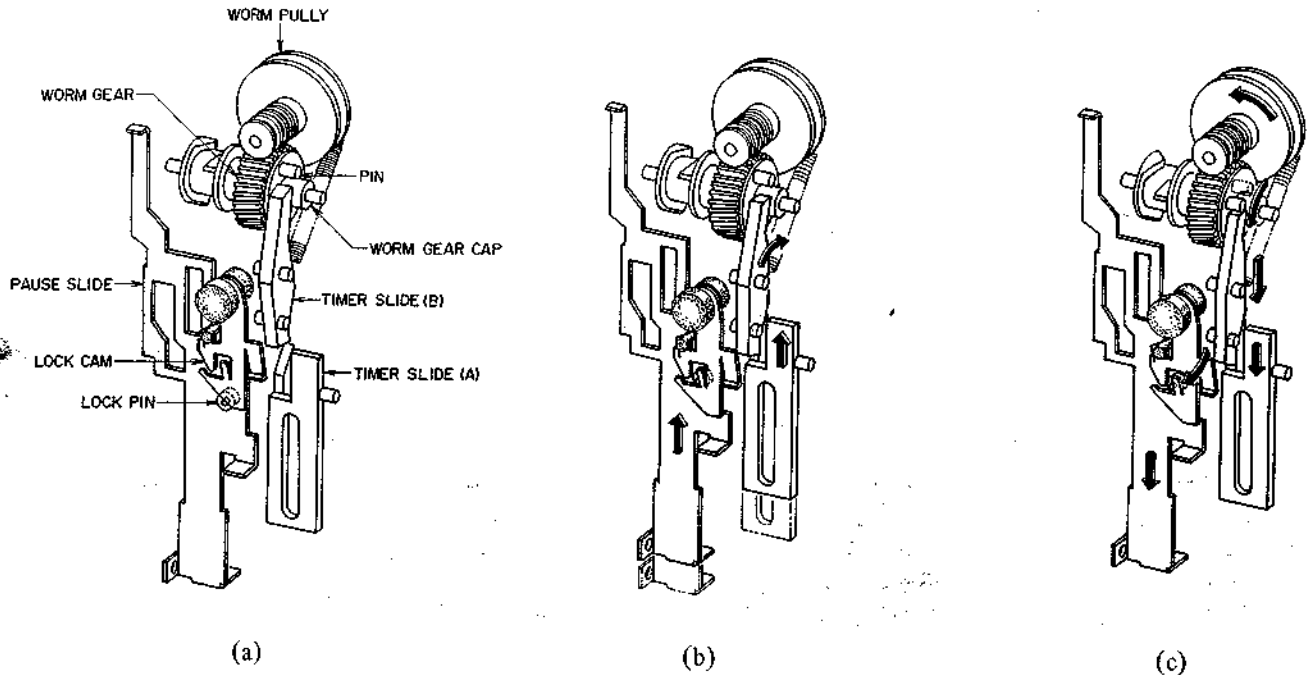

Fig. 5

The **TIMER START SWITCH** is designed to put the deck in the **REC** or **PLAY** modes by releasing the **PAUSE** key automatically (the **PAUSE**, **REC** and **PLAY** keys have already been depressed) when the power is turned on by the timer.

In the **PAUSE** mode, the **PAUSE SLIDE** is lifted up and fixed by attaching the **LOCK PIN** to the **LOCK CAM** so to release the **PAUSE** mode all you have to do is to detach the **LOCK PIN** from the **LOCK CAM**.

When put into the **PAUSE** mode, the **LOCK PIN** is attached to the **LOCK CAM** and the **PAUSE SLIDE** is locked. When the **TIMER START SWITCH** is put on **TIMER SLIDE (A)** moves upwards and as a result, **TIMER SLIDE (B)** moves upwards to the inside in the direction of the arrow and downwards to the outside. See Fig. 5 (b).

If the power switch is turned on here, the **WORM PULLEY** and the **WORM GEAR** revolve. The pin on the **WORM GEAR CAP** moves in the direction of the arrow **TIMER SLIDE (B)** is pushed down so the **LOCK CAM** is pushed upwards by this section. Then the **LOCK PIN** is detached, the **PAUSE SLIDE** lowers and the **PAUSE** key is released. The **TIMER START SWITCH** is also released because **TIMER SLIDE (A)** is pushed down by **TIMER SLIDE (B)**.

VIII. MECHANISM ADJUSTMENT

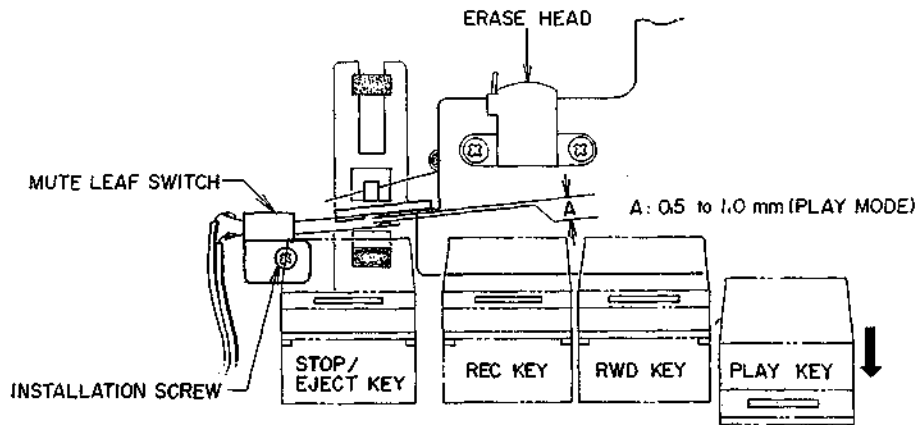

Fig. 9

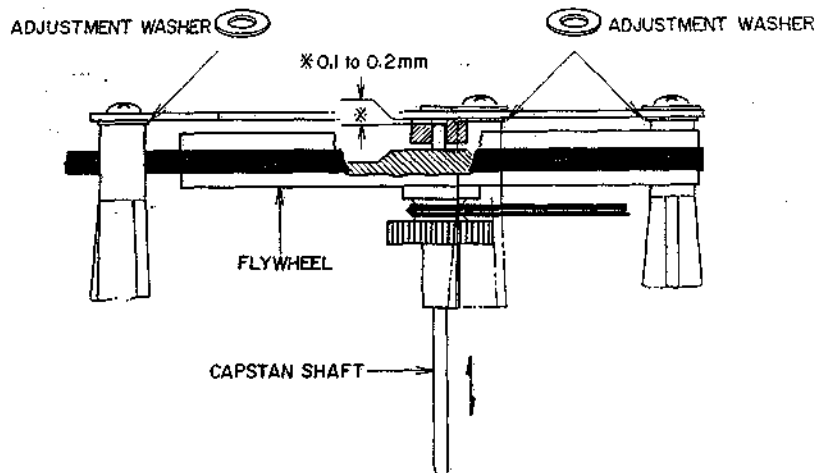

Fig. 10

1. MUTE LEAF SWITCH INSTALLATION POSITION ADJUSTMENT (Refer to Fig. 9)

When in the playback mode, the space A should be 0.5 to 1.0 mm as in Fig. 9. To adjust, turn the leaf switch installation screw.

Confirm the switch stays in the same position when the RWD and PLAY keys are depressed together.

2. FLYWHEEL LOOSE PLAY ADJUSTMENT (Refer to Fig. 10)

Insert the various washers in the three places between the prop and the flywheel hold plate and adjust to give 0.1 to 0.2 mm loose play when the flywheel is moved in the direction of the arrows.



AUTO STOP puts the deck into the STOP mode by releasing the keys when the end of the tape is reached in the PLAY, FF, RWD REC/PB modes.

1. HOW EACH PART OPERATES

a. CLUTCH PLATE (B) (Fig. 6)

There is felt attached to this and friction force is generated (Shown by the arrow) and it seems as if it is pushing the AS ARM outwards.

b. AS LEVER (Fig. 6, 8)

The pin attached to the rear of the AS LEVER enters the groove of the WORM GEAR. It touches against the  section A as the WORM GEAR revolves and moves to the left or right or is pushed down by  section B.

c. RELEASE LEVER (Fig. 6)

Adds the same friction force to the AS ARM by pulling down the AS ARM Spring in the pause mode as when the reel revolves.

2. When put into the PLAY (FF, RWD) mode the fly-wheel revolves and the WORM pulley and WORM gear revolves. The reel revolves and the CLUTCH PLATE (B) goes to push the AS ARM outwards with the friction force so the pin at the rear of the AS LEVER receives this force to the left then it contacts the ridged section  A of the WORM GEAR and move to the left and right.

At the end of the tape, the reel stops revolving so the friction disappears. In the PLAY (FF, RWD) mode the RELEASE LEVER drops so friction is not added to the AS ARM from the AS ARM SPRING.

The Worm Lever continues to revolve and the AS LEVER pin is taken up to the top of the ridged  section where it then stops.

It is then pushed down by the WORM GEAR section B , and pushes down the AS SLIDE with the AS LEVER and releases the PLAY (FF, RWD) keys. When the PAUSE key is depressed from the PLAY mode the reel stops revolving and the force from the CLUTCH PLATE to the AS ARM stops. However the PAUSE SLIDE moves upwards and pushes up the RELEASE LEVER which had been held down so the same force is applied as to the AS ARM by the AS ARM SPRING so AUTO STOP does not operate.

IX. HEAD ADJUSTMENT

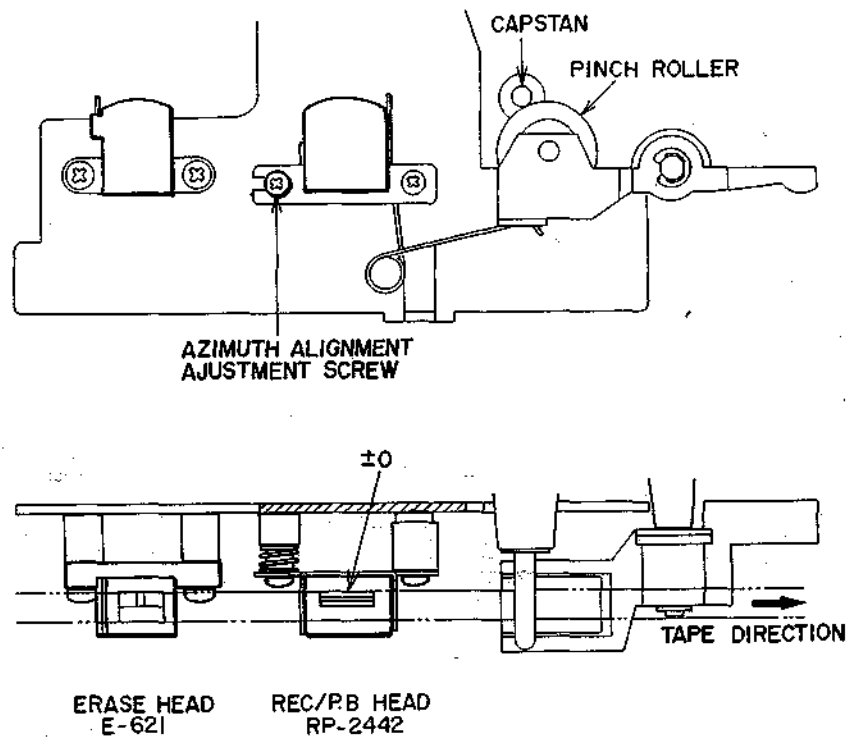

Fig. 13 Head Adjustment

1. RECORDING/PLAYBACK HEAD

AZIMUTH ALIGNMENT (Refer to Fig. 13)

- Playback a 10 kHz pre-recorded cassette azimuth alignment test tape and adjust screw shown in Fig. 13 to obtain maximum output on both channels.
- Invert cassette and confirm that the output level does not change from that obtained in Item 1-a) above. If the output level differs, adjust in the same way as in Item 1-a) above until both sides of the test tape display equal output.

NOTES:

- Be sure to clean the heads prior to head adjustment.
- Be careful not to use a magnetized driver or other magnetized tools in the vicinity of the heads.
- Be sure to demagnetize the heads with a Head Demagnetizer before and after head adjustment.

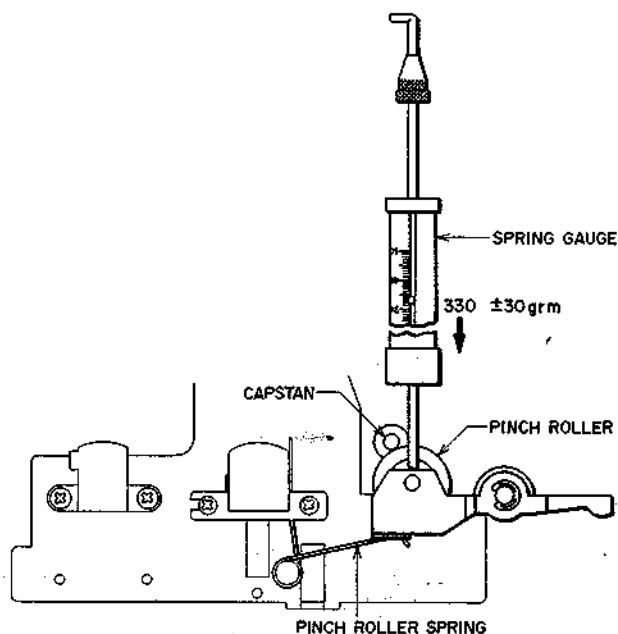

Fig. 11

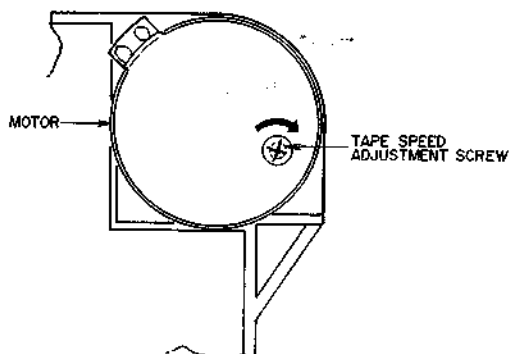

Fig. 12

3. PINCH ROLLER PRESSURE MEASUREMENT (Refer to Fig. 11)

At playback mode, push the pinch roller with a spring gauge until the pinch roller separates from the capstan by about 1 mm to 2 mm and then gently return. Take a reading of the spring gauge indication at the moment the pinch roller touches the capstan and begins to rotate.

Specified Pinch Roller Pressure : 330 ± 30 gm
 In case specified pressure cannot be attained, replace the pinch roller spring.

4. WINDING TORQUE MEASUREMENT IN EACH MODE

Insert cassette torque meter and measure in each mode. For fast forward and rewind measure at the end of the tape when the tape has stopped running. The specified torque is:

Playback : 35 to 60 g-cm

Fast Forward, Rewind : 80 to 120 g-cm

In case specified take-up torque cannot be attained.

Playback mode : Replace Take-up Reel Table Block.

Fast Forward or Rewind mode :

Replace Middle Gear Block.

5. TAPE SPEED ADJUSTMENT

(Refer to Fig. 12)

Connect the frequency counter to the line output terminals. Playback a 1,000 Hz pre-recorded test tape and adjust tape speed adjustment screw to obtain a tape speed of $1,000 \text{ Hz} \pm 1\%$.

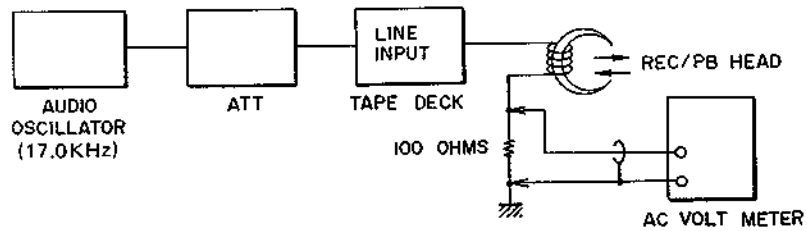

Fig. 16 Instrument Connection

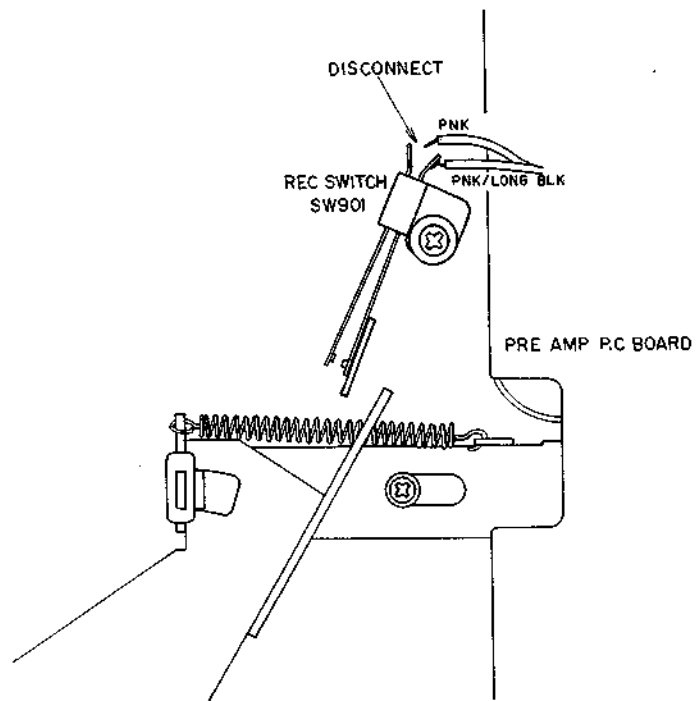
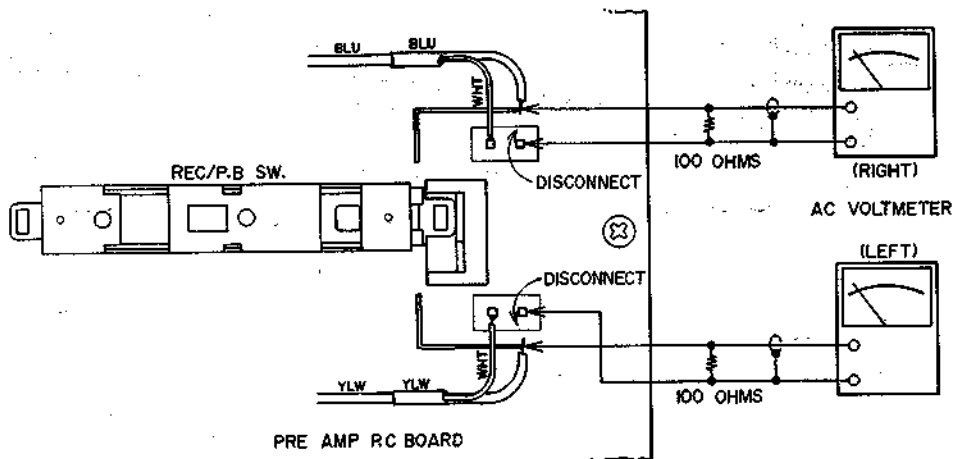
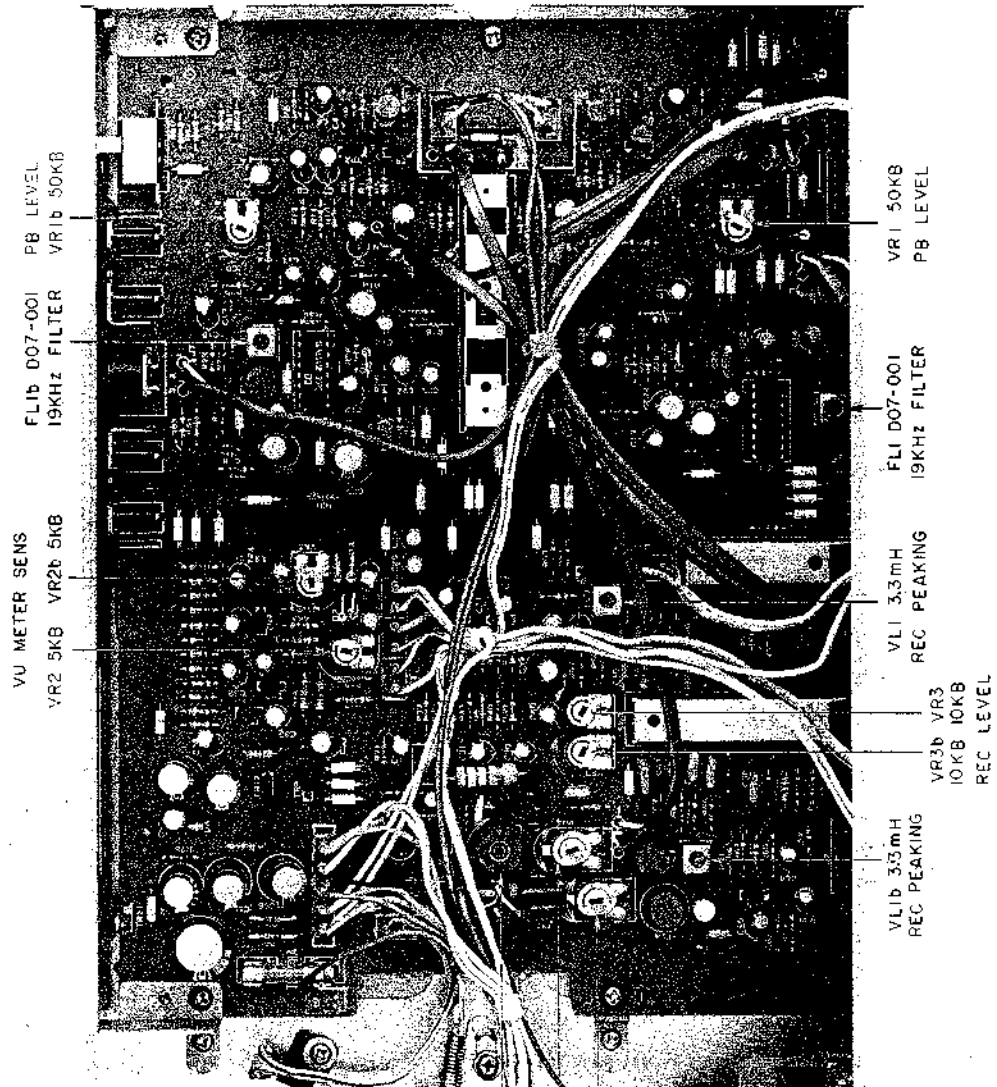

Fig. 17 Rec Peaking Adjustment

X. AMPLIFIER ADJUSTMENT



Use the label 'b' following an adjustment parts number label as "RIGHT CHANNEL"

VR4 VR4b
100KB 100KB
FREQUENCY RESPONSE

T1 DSM-003
BIAS OSCILLATION
FREQUENCY

Fig. 14 Pre Amp P.C Board CE-5301A

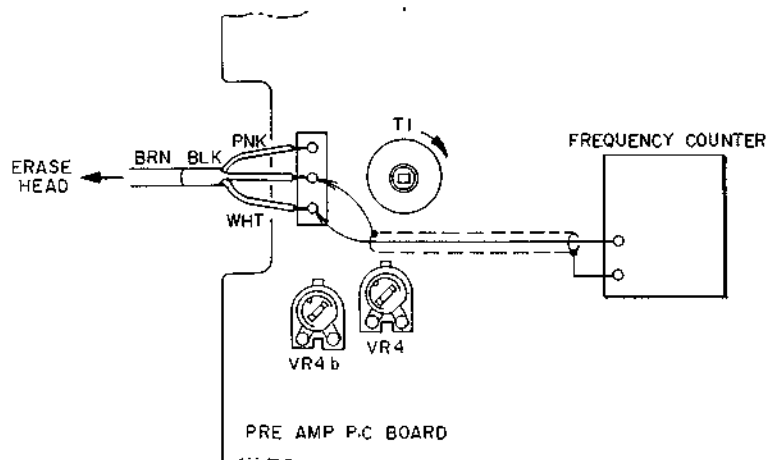

Fig. 15 Bias Oscillation Frequency Adjustment

XI. DC RESISTANCE OF HEADS

Parts	Designation	DC Resistance
REC/PB Head	RP-2442	260 ohms \pm 20%
Erase Head	E-621	5 ohms \pm 20%

Chart-2

XII. CLASSIFICATION OF VARIOUS P.C BOARDS

1. P.C BOARD TITLES AND IDENTIFICATION P.C BOARDS

P.C Board Title	P.C Board Number
Pre Amp P.C Board	CE-5301A
Power Switch P.C Board (A)	CE-5302
Power Switch P.C Board (B)	CE-5303
Power Switch P.C Board (C)	CE-5304
REC LED P.C Board	CE-5301B
Dolby LED P.C Board	CE-5301C
Volume P.C Board	CE-5301D
Lamp P.C Board	CE-1078

Chart-3

Step	Adjustment Item	Test Tape Supply Signal	Mode	Adjustment Point	Result	Remarks
1	Playback Level	333 Hz, 0 VU Test Tape	PB	VR 1 50 kB	-5.5 ± 0.5 dBm (410 mV)	
2	VU Meter Sensitivity	1,000 Hz -5.5 dBm from oscillator	REC	VR 2 5 kB	0 VU indication	
3	Bias Oscillation Frequency Adjustment	No Signal input	REC	T1	85 kHz	See the Figs. 14, 15.
4	Rec Peaking adjustment	17.0 kHz -25.5 dB from oscillator	REC	VL 1 3.3 mH	AC Voltmeter indicates to maximum	Tape selector to Normal. See the Figs. 14, 16, 17. NOTES 6, 10.
5	Normal Position Frequency Response	LN Blank tape 1,000 Hz, 10,000 Hz -25.5 dBm recording	REC/PB	VR4 100 kB	1,000 Hz to 10,000 Hz flat	
6	CrO ₂ , FeCr Each position Frequency Response Confirmation	CrO ₂ , FeCr Blank tape 1,000 Hz, 10,000 Hz -25.5 dBm recording	REC/PB		1,000 Hz to 10,000 Hz flat	Set tape selector to CrO ₂ or FeCr Position NOTE 7.
7	Recording Level	LN Blank tape 1,000 Hz -5.5 dBm recording	REC/PB	VR 3 10 kB	-5.5 ± 0.5 dBm	Set the MIC Volume to minimum
8	Distortion Factor Confirmation	1,000 Hz -5.5 dBm recording	REC/PB		Normal < 0.8% CrO ₂ < 0.7% FeCr < 0.7%	NOTE 8.
9	19 kHz Filter adjustment	19 kHz from oscillator	REC	FL 1 D07-001	AC Voltmeter indicates to minimum	Set Dolby NR Switch to ON, Filter ON position. NOTE 9, 10.

Chart-1

- NOTES:**
- Input selector switch to LINE.
(The AAL Model do not have this facility.)
 - Because each of these adjustments is vital to perfect Dolby NR circuit operation, ensure that they are carried out with as few errors as possible.
 - Except for Step 6 and 8, set Tape Selector to NORMAL Position.
 - Except for Step 9, set Dolby NR switch to OFF Position.
 - Use the following cassette measuring tapes:

Normal Tape	:	Maxell UD	C-60
CrO ₂ Tape	:	TDK SA	C-60
FeCr Tape	:	SONY DUAD	C-60
 - Stop the recording bias oscillator while making record peaking adjustment (Refer to Fig. 17).
 - If a flat characteristic cannot be obtained from 1,000 Hz to 10,000 Hz at CrO₂ or FeCr positions, carry out adjustment step 5 once again.
 - If it does not comply with the specifications, repeat Steps 5 to 7 and readjust.
 - Adjust the oscillator's frequency to give a frequency counter reading of 19.00 kHz.
 - Unless the core is moved unintentionally this adjustment is not necessary.

2. COMPOSITION OF VARIOUS P.C BOARDS

1) PRE AMP P.C BOARD CE-5301A (3ED), REC LED P.C BOARD CE-5301B DOLBY LED P.C BOARD CE-5301C, VOLUME P.C BOARD CE-5301D and LAMP P.C BOARD CE-1078

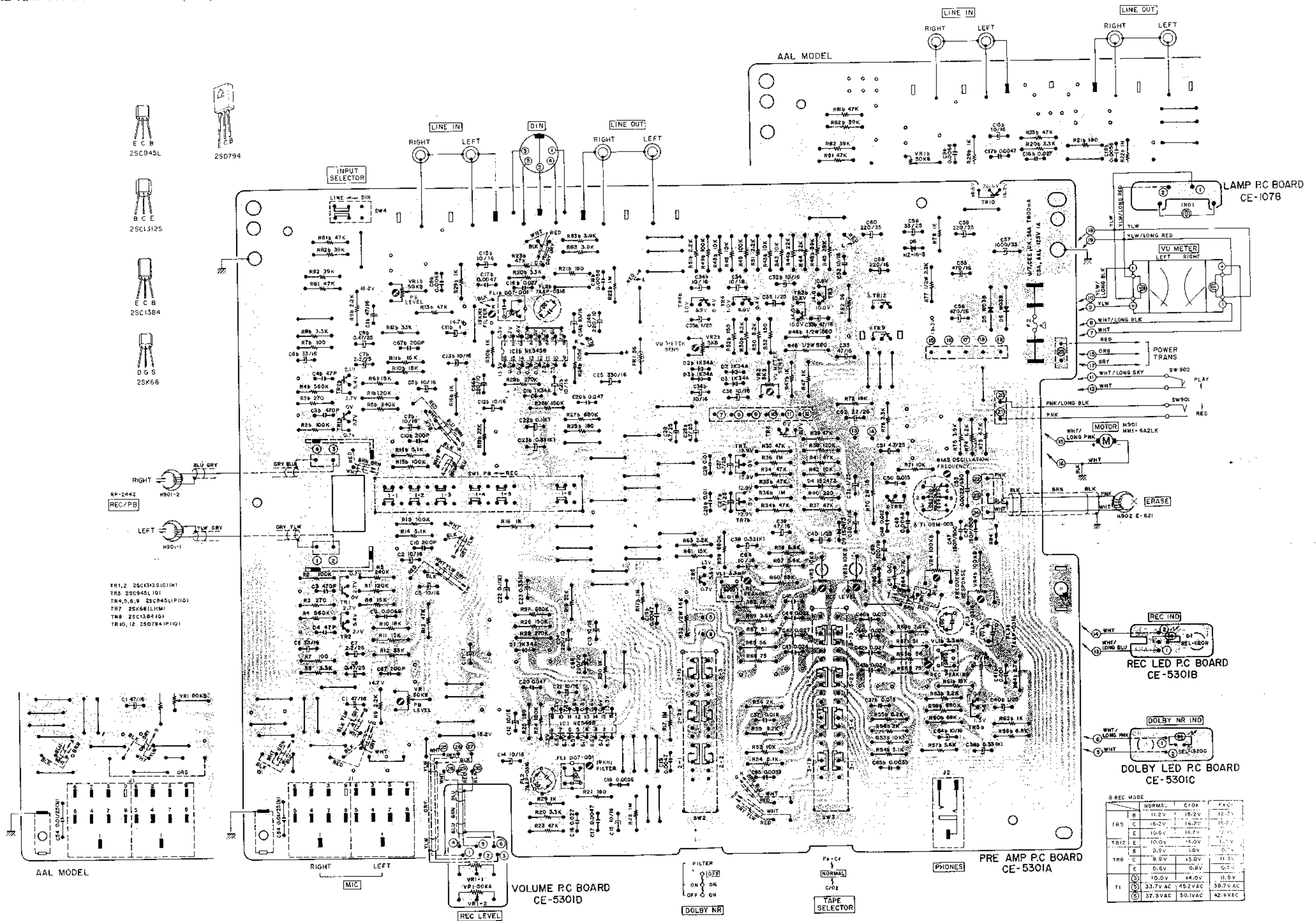

2) POWER SWITCH P.C BOARD (B) CE-5303 (U/T)

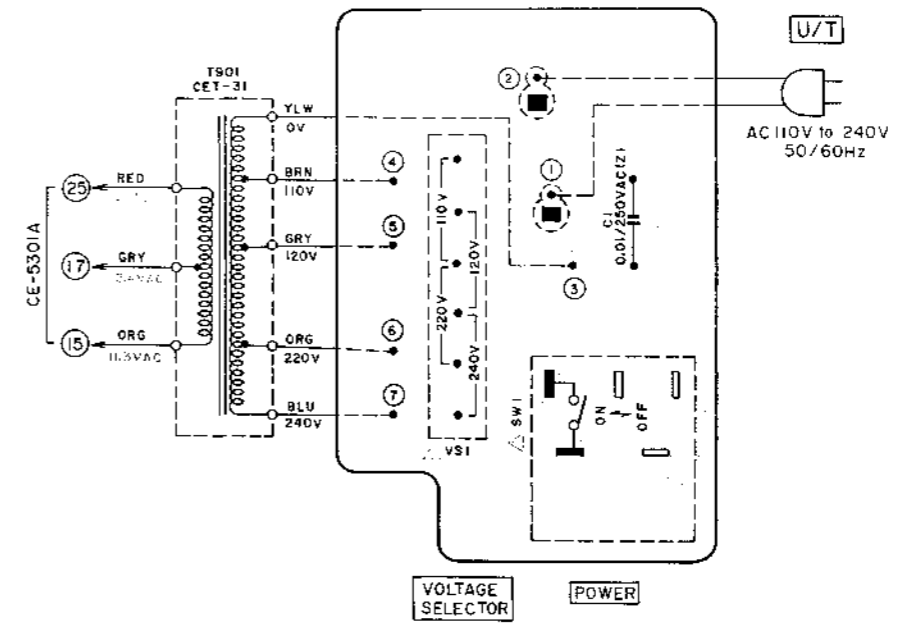

3) POWER SWITCH P.C BOARD (A) CE-5302 (CSA, AAL)

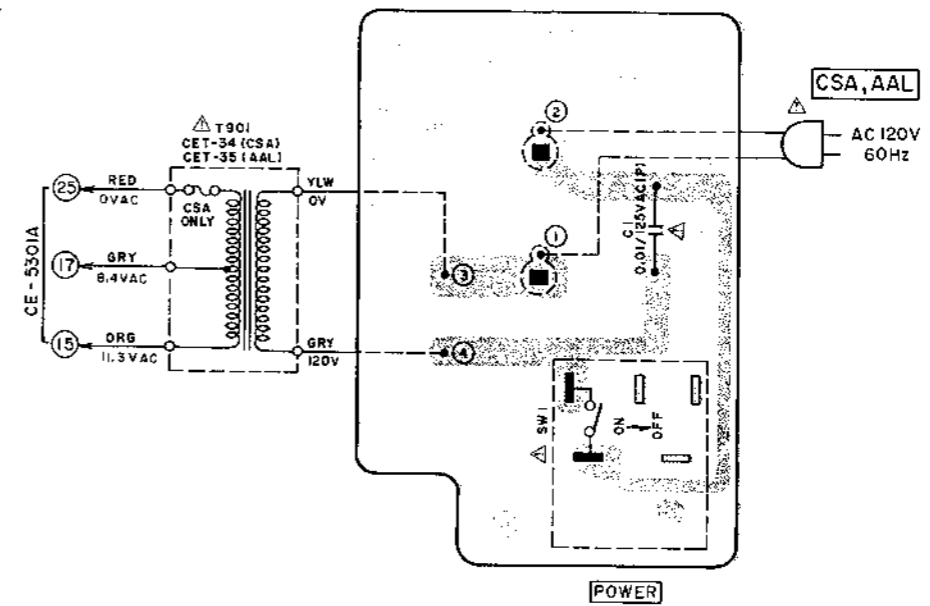

WARNING: Δ INDICATES SAFETY CRITICAL COMPONENTS. FOR CONTINUED SAFETY, REPLACE SAFETY CRITICAL COMPONENTS ONLY WITH MANUFACTURER'S RECOMMENDED PARTS.
 AVERTISSEMENT: Δ IL INDIQUE LES COMPOSANTS CRITIQUES DE SÉCURITÉ. POUR MAINTENIR LE NIVEAU DE SÉCURITÉ DE L'APPAREIL, NE REMPLACEZ QUE LES COMPOSANTS DONT LE FONCTIONNEMENT EST CRITIQUE AVEC DES PIÈCES RECOMMANDÉES PAR LE FABRICANT.

4) POWER SWITCH P.C BOARD (C) CE-5304 (CEE, UK, SAA)

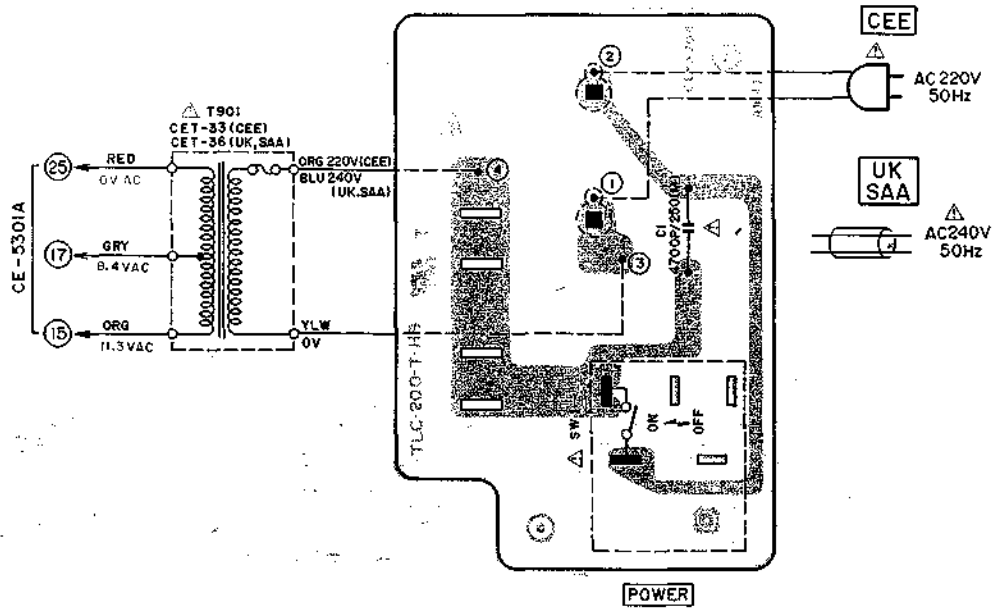

WARNING: Δ INDICATES SAFETY CRITICAL COMPONENTS. FOR CONTINUED SAFETY, REPLACE SAFETY CRITICAL COMPONENTS ONLY WITH MANUFACTURER'S RECOMMENDED PARTS.

AVERTISSEMENT: Δ IL INDIQUE LES COMPOSANTS CRITIQUES DE SÛRETÉ. POUR MAINTENIR LE DEGRÉ DE SÛRETÉ DE L'APPAREIL, NE REMPLACEZ LES COMPOSANTS DONT LE FONCTIONNEMENT EST CRITIQUE POUR LA SÛRETÉ QUE PAR DES PIÈCES RECOMMANDÉES PAR LE FABRICANT.

MEMO

MEMO

MEMO

SECTION 2

PARTS LIST

TABLE OF CONTENTS

1. RECOMMENDED SPARE PARTS LIST	28
2. HEAD BLOCK	30
3. MECHA BLOCK (1)	31
4. MECHA BLOCK (2)	32
5. PRE AMP P.C BOARD (CE-5301A) BLOCK	34
6. ASSEMBLY BLOCK	35
7. FINAL ASSEMBLY BLOCK	36
INDEX.	37

Resistor and Capacitor which is not listed in this parts list, please refer to COMMON LIST FOR SERVICE PARTS.

HOW TO USE THIS PARTS LIST

1. This parts list is compiled by various individual blocks based on assembly process.
2. When ordering parts, please describe parts number, serial number, and model number in detail.
3. How to read List

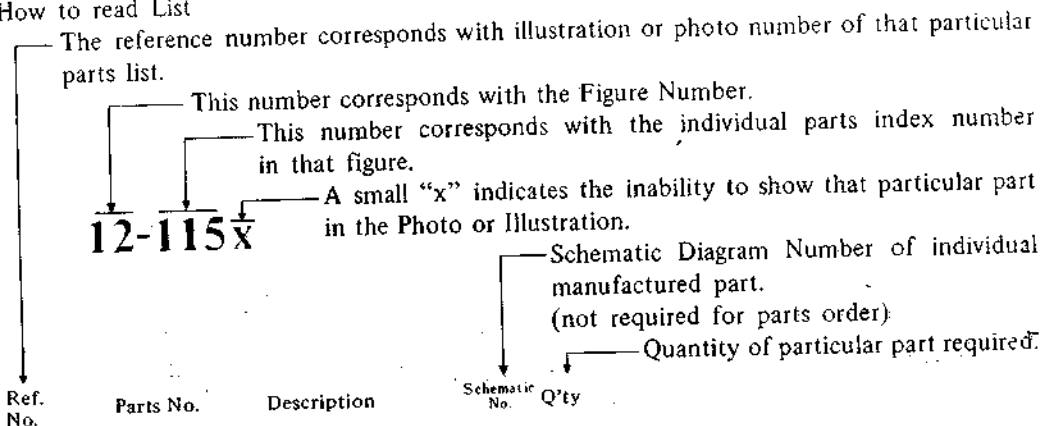

4. The symbol numbers shown on the P.C. Board list can be matched with the Composite Views of Components of the Schematic Diagram or Service Manual.
5. Please utilize separate "Common List for Service Parts" for Resistor Parts orders.
6. The shape of the parts and parts name, etc. can be confirmed by comparing them with the parts shown on the Electrical Parts Table of P.C. Board.
7. Both the kind of part and installation position can be determined by the Parts Number. To determine where a parts number is listed, utilize Parts Index at end of Parts List.
It is necessary first of all to find the Parts Number. This can be accomplished by using the Reference Number listed at right of parts number in the Parts Index. (meaning of ref. no. outlined in Item 3 above).
8. Utilize separate "Price List for Parts" to determine unit price. The most simple method of finding parts Price is to utilize the reference number.

AC INLET SYSTEM

This model is equipped with an AC INLET SYSTEM. Please refer to the AC INLET SYSTEM CHART below for the specific type. By the AC INLET SYSTEM, AC (mains) cord can be connected to and disconnected from the model because the model is provided with socket exclusively for AC (mains) cord on its main body. Please note, however, that certain models are not equipped with this system and has a built-in AC (mains) cord as before.

AC INLET SYSTEM CHART

CLASS I

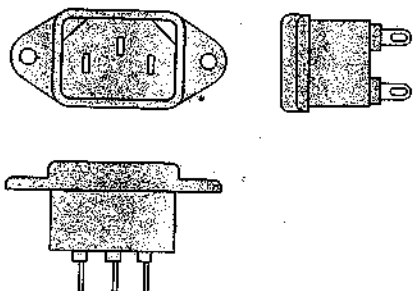

Picture 1
AC INLET
to be
installed
on machines

CLASS II

☐ This mark indicating double insulation will be attached to machine's rear panel

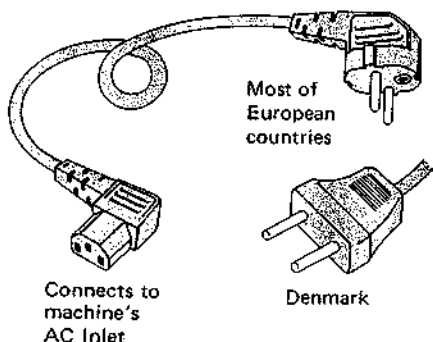
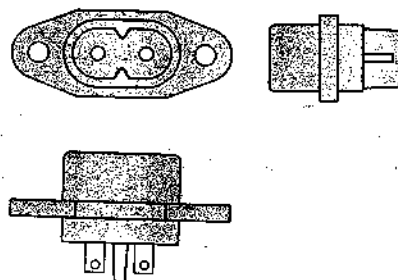

Picture 2
AC (mains)
cord

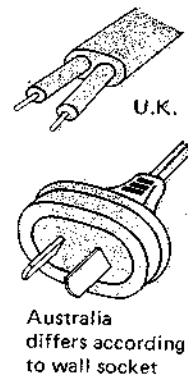
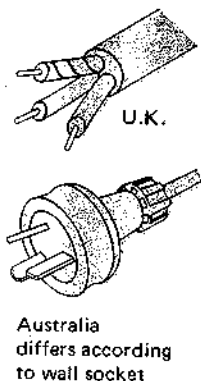
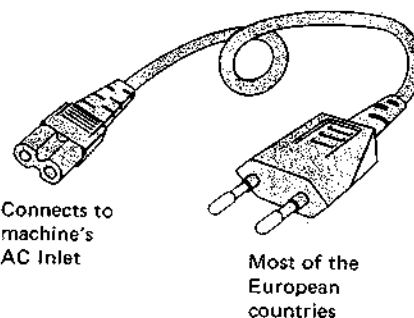

Parts List for AC (mains) Cord Set

Standard		Description	Type of AC Inlet	Parts No.
Class I	CEE	Cord Set CEE (3 cores)	3P	EW302993
	BEAB	Cord Set BEAB (3 cores)	3P	EW302994
	SAA	Cord Set SAA (3 cores)	3P	EW302996
	U/T	Cord Set U/T (3 cores)	3P	EW302646
Class II	CEE	Cord Set CEE (2 cores)	2P	EW638144
	BEAB	Cord Set BEAB (2 cores)	2P	EW302995
	SAA	Cord Set SAA (2 cores)	2P	EW302991
	U/T	Cord Set U/T (2 cores)	2P	EW302899

1. RECOMMENDED SPARE PARTS LIST

Because, if the parts listed below are on hand, almost any repair can be accomplished, we suggest that you stock these Recommended Spare Parts Items.

Parts No.	Description	Notes
BA323894	Pre Amp P.C Board Comp. CS-M01 (JPN)	
BA323893	Pre Amp P.C Board Comp. CS-M01 (U/T)	U/T, CEE, UK, SAA
BA320995	Pre Amp P.C Board Comp. CS-M01 (AAL)	
BA320996	Pre Amp P.C Board Comp. CS-M01 (CSA)	
BH323920	Head BLK CS-M01	
BL319692	Pinch Roller BLK GX-M10	
BM319691	Motor BLK GX-M10	
BR321539	Supply Reel Table BLK	
BR321540	Take-up Reel Table BLK	
BT323939	△ Power Trans. CET-31	U/T
BT323940	△ Power Trans. CET-32	JPN
BT323941	△ Power Trans. CET-33	CEE
BT323942	△ Power Trans. CET-34	CSA
BT324373	△ Power Trans. CET-35	AAL
BT323944	△ Power Trans. CET-36	UK, SAA
ED308952	Germanium Diode 1K34A-LR	
ED320469	LED SEL-1120R	
ED325330	LED SEL-1320G	
ED323979	Silicon Diode W03B	
ED624903	Silicon Diode 1S2473	
ED560913	Silicon Diode 1S2473 VE	
ED313846	Zener Diode HZ16-3	
EF310229	△ Fuse 1A 125V	CSA, AAL
EF309387	△ Fuse 1A 250V	JPN
EF623103	△ Fuse (Semko T) 1AT	U/T, CEE, UK, SAA
EI605013	IC NE545B	
EJ308985	DIN, Pin Jack 4P	Ext. JPN, AAL
EJ316156	Head Phone Jack HLJ0315-01-020	
EJ321328	Jack HLJ0345-01-010	
EJ308986	Pin Jack 4P	JPN, AAL
EL323981	Lamp (Fuse Type) 8V 55MA	
EM323852	VU Meter KL-270U-1	
EM323854	VU Meter KL-270U-2	BL
EO310608	Ferri Inductor FE-001 3.3MH	
EO325354	OSC Coil OSM-003	
EO310875	Trap Coil 7AAP-0316	
ER309119	Dolby Filter D07-001	
ER319455	Fuse/R. F 1/4W 10 ohms (G)	
ER319510	Fuse/R. 1/4W 56 ohms (J)	
ES315159	△ Push SW. SDG1P (JPN)	JPN

Parts No.	Description	Notes
ES310839	△ Push SW. SDG1P-E 5A/80A 250V	U/T, CEE, UK, SAA
ES301747	Leaf SW. BSW-1F TX-2	
ES283173	Leaf SW. BUW-31PLC	
ES321274	Lever SW. 63349	
ES315748	Lever SW. 83157	
ES283072	Slide SW. SSC22LP	
ES310591	Slide SW. 122074	
ET304169	FET 2SK68 (L) (M)	
ET603257	Transistor 2SC1312S (G) (H)	
ET241334	Transistor 2SC1384 (Q)	
ET399846	Transistor 2SC945L (Q)	
ET639437	Transistor 2SC945L (Q) (P)	
ET307349	Transistor 2SD794 (P) (Q)	
EV325331	Double-Axial 2-Throw/vol. DM80R 50kAx2	
EV314968	Semi-Fixed/Vol. D10 Axial 100kB	
EV315412	Semi-Fixed/Vol. D8 Axial 5kB	
EV315413	Semi-Fixed/Vol. D8 Axial 50kB	
EV315416	Semi-Fixed/Vol. D8 Axial 10kB	
EW306427	△ AC Cord (JPN)	
EW306428	△ AC Cord (U/T)	
EW313884	△ AC Cord BASEC	UK
EW305691	△ AC Cord CUL	CSA, AAL
EW313882	△ AC Cord EC	CEE
EW313883	△ AC Cord SAA	SAA
HE323856	Erase Head E-621	
HP323857	REC/PB Head RP-2442	
MB321391	AS Belt	
MB321389	Capstan Belt	
MB296458	Counter Belt	
MC321559	Counter MP390-384	
MC321560	Counter MP390-385	BL
MI319709	Flywheel Part GX-M10	
ML319693	AS Arm Assy	

2. HEAD BLOCK

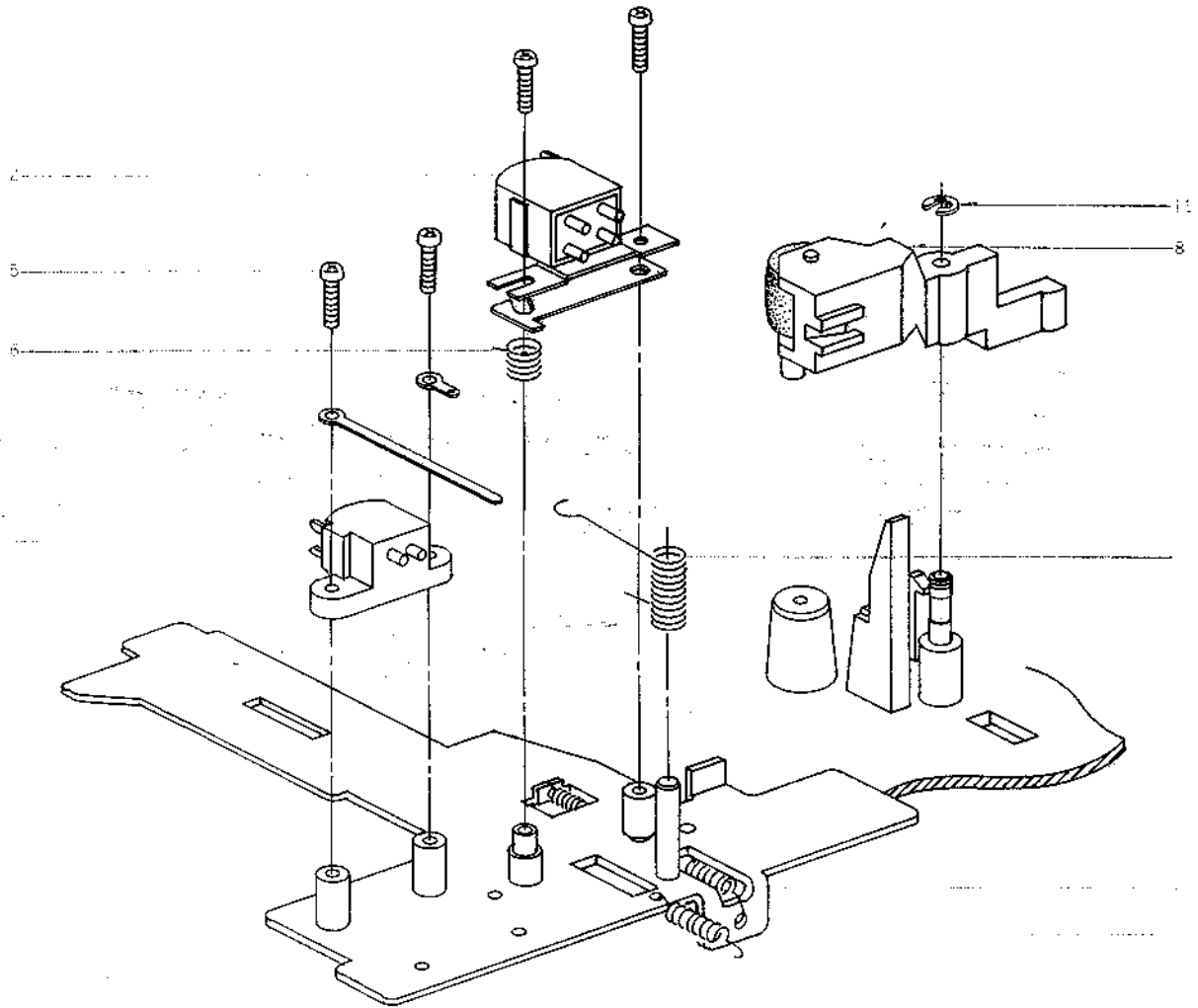

HEAD BLOCK

Ref. No.	Parts No.	Description	Schematic No.
HEAD BLOCK			
2-1x	BH323920	Head BLK CS-M01	
2-2	HP323857	REC/PB Head RP-2442	37-2-34
2-3	HE323856	Erase Head E-621	37-2-35
2-4	ZS608106	Screw, Pan 2x6	
2-5	ZS419940	Screw, Pan 2.3x6	
2-6	ZG321459	Azimuth Spring	CE-0011
2-7	ZG321358	Pinch Spring (A)	CE-0006
PINCH ROLLER BLOCK			
2-8	BL319692	Pinch Roller BLK GX-M10	CE-1202
MECHA BLOCK			
2-9	ZG300206	Eject Spring	CM-1053
2-10	ZG321535	PB Spring	CE-1063
2-11	ZW357164	'E' Ring 2.3M	619

When ordering parts, please describe Parts Number, Description, and Model Number in detail.

3. MECHA BLOCK (1)

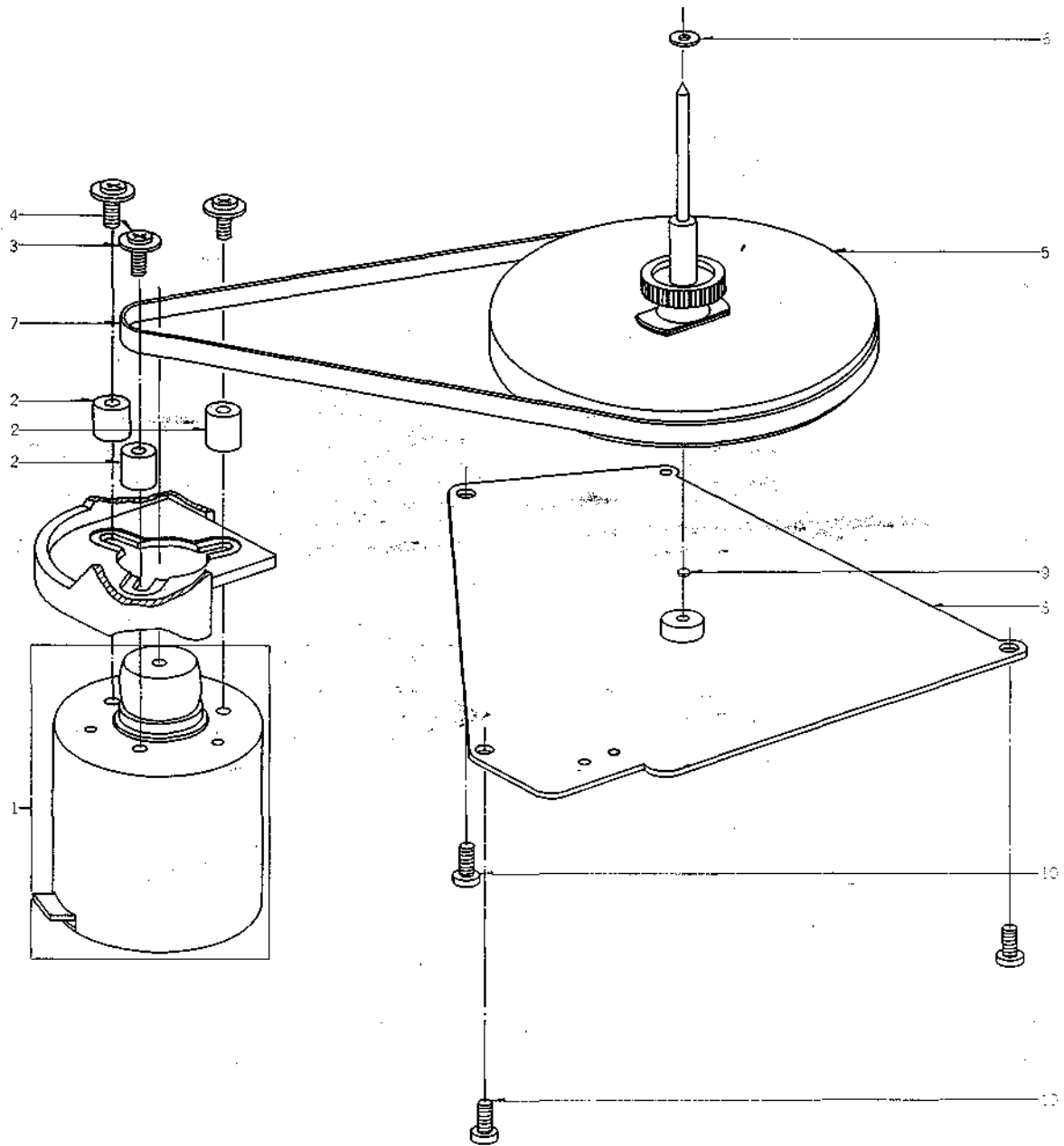

MECHA BLOCK (1)

Ref. No.	Parts No.	Description	Schematic No.
MOTOR BLOCK			
3-1	BM319691	Motor BLK GX-M10	CE-7201
MECHA BLOCK			
3-2	MB326135	Motor Bush	CE-7002
3-3	ZW550642	Washer (SPC) D3.1x8x0.5t	
3-4	ZS479474	Screw, Pan 2.6x5	
3-5	MI319709	Flywheel Part GX-M10	CE-1025
3-6	ZW269335	Washer (Nylon) D2.3x6x0.3t	
3-7	MB321389	Capstan Belt	CE-1027
3-8	TC319914	Flywheel Hold Plate (A) Part	CE-1061
		CS-M02	
3-9	ZW321424	Thrust Washer	CE-1063
3-10	ZS310984	P-Tight Screw, BR 3x8	7-1-80

When ordering parts, please describe Parts Number, Description, and Model Number in detail.

4. MECHA BLOCK (2)

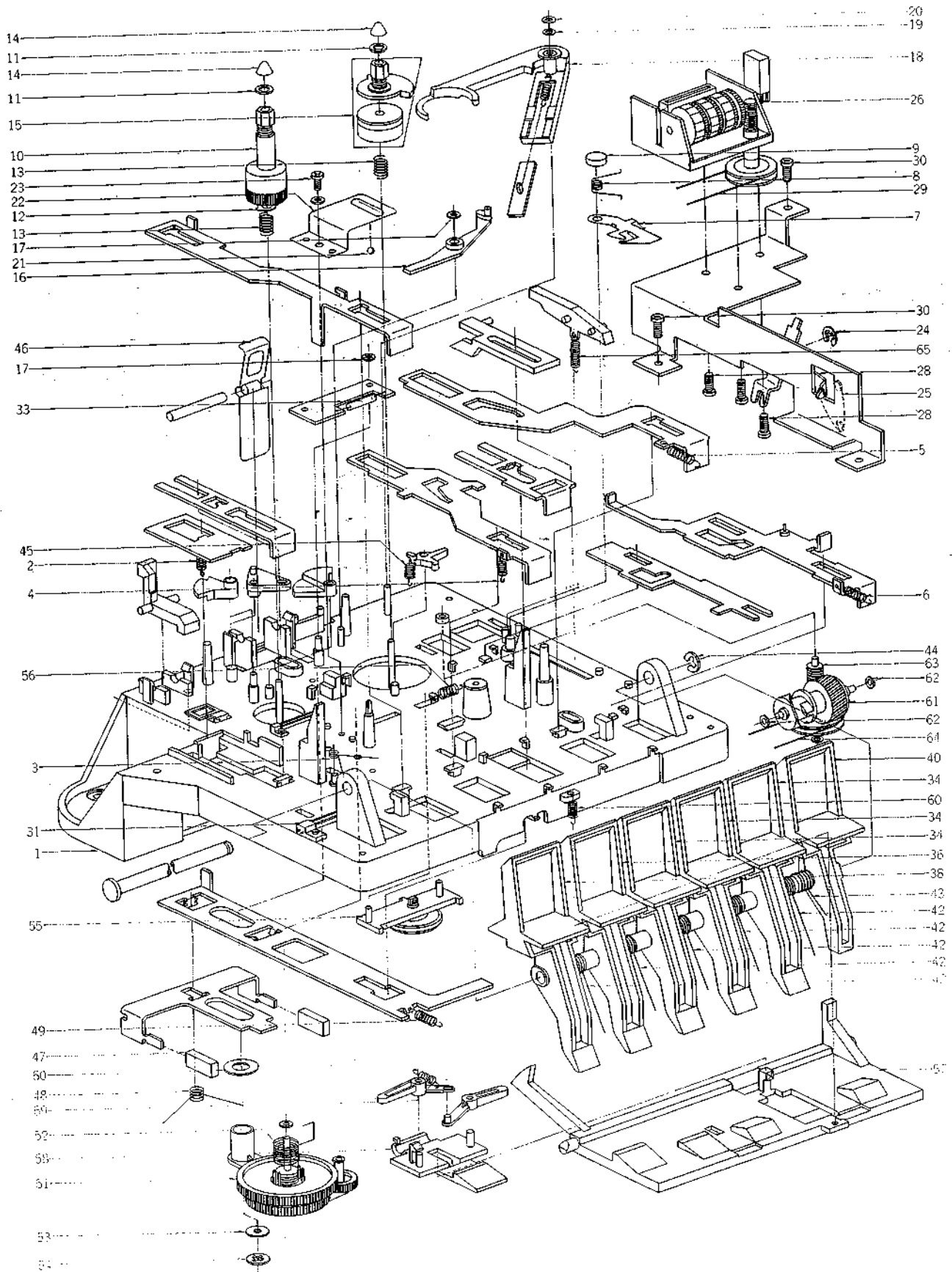

MECHA BLOCK (2)

Ref. No.	Parts No.	Description	Schematic No.
4-1	TC319723	Chassis Part GX-M10	CE-1001
4-2	ZG312926	Coil Spring T1-3.2/0.2-16.0	
4-3	ZG321373	Stop Spring	CE-1007
4-4	ZG312943	Coil Spring T1-3.2/0.29-11.2	
4-5	ZG324329	Coil Spring T2-3.2/0.29-11.2	
4-6	ZG324330	Pause Spring	CE-1085
4-7	MZ321396	Lock Cam	CE-1034
4-8	ZG514440	Button Lock Spring (B)	CG-2303
4-9	TC282396	Cap	CN-1055
4-10	BR321539	Supply Reel Table BLK	9-3-60
4-11	ZW381644	Washer (Polyslider) D2.1x4x0.13t	
4-12	ZW321393	BT Washer	CE-1030
4-13	ZG321538	BT Spring	CE-1081
4-14	MT305793	Reel Cap	CF-2039
4-15	BR321540	Take-up Reel Table BLK	9-3-61
4-16	ML321404	Release Lever	CE-1043
4-17	ZW340648	Clip (CS Type) CSTW-2	6-1-14
4-18	ML319693	AS Arm Assy	CE-1203
4-19	ZW305546	Washer (Polyslider) D2.1x4x0.25t	
4-20	ZW321437	Push Washer	CE-1077
4-21	MV368886	Steel Ball D3	
4-22	ZG321384	Hold Spring	CE-1021
4-23	ZS310343	Special Tapping Screw, Pan 3x6	7-1-70
4-24	ZW270101	'E' Ring 3M	6-1-9
4-25	ZG321411	Timer Spring	CE-1050
4-26	MC321559	Counter MP390-384	9-1-86
4-27x	MC321560	Counter MP390-385 (BL)	9-1-87
4-28	ZS200384	Screw, Countersunk 3x6	
4-29	MB296458	Counter Belt	CM-1023
4-30	ZS310984	P-Tight Screw, BR 3x8	7-1-80
4-31	ES283173	Leaf SW, BUW-31PLC	25-10-26
4-32x	ZS321320	B-Tight Screw, Pan 2x6	
4-33	EL323981	Lamp (Fuse Type) 8V 55mA	28-2-88
4-34	SK321362	Key Board Knob (A)	CE-1002
4-35x	SK321363	Key Board Knob (A-BL)	CE-1002
4-36	SK321364	Key Board Knob (D)	CE-1002
4-37x	SK321365	Key Board Knob (D-BL)	CE-1002
4-38	SK321367	Key Board Knob (B)	CE-1003
4-39x	SK321368	Key Board Knob (B-BL)	CE-1003
4-40	SK321369	Key Board Knob (C)	CE-1004
4-41x	SK321370	Key Board Knob (C-BL)	CE-1004
4-42	ZG321430	Key Board Spring (A)	CE-1069
4-43	ZG321431	Key Board Spring (B)	CE-1070
4-44	ZW270123	'E' Ring 4M	6-1-9
4-45	ZG321544	Relay Lever Spring	CE-1082
4-46	MZ321417	Cassette Holder	CE-1055
4-47	TC321415	Brake Shoe	CE-1053
4-48	ZG321416	Brake Spring	CE-1054
4-49	ZG318228	Coil Spring T2-3.2/0.29-14	
4-50	ZW319376	Washer (Polyslider) D6.2x13x0.25t	
4-51	BZ321546	Middle Gear BLK	9-3-62
4-52	ZG325100	Gear Return Spring	CE-1087
4-53	ZW460787	Washer (Polyslider) D3.1x8x0.25t	
4-54	ZW653163	Retaining Ring CS Type 3	6-1-14
4-55	BZ321547	Take-up Idler BLK	9-3-63
4-56	ZG312920	Coil Spring T1-3.2/0.2-8.0	
4-57	MZ321418	Key Board Cam	CE-1056
4-58	MZ321419	PB Cam	CE-1057
4-59	ZG321549	Coil Spring T2-3.2/0.2-10.0	
4-60	ZG321548	Key Board Cam Spring	CE-1084
4-61	TC319724	Worm Gear Part GX-M10	CE-1039
4-62	ZW321317	Washer (Polyslider) D2.1x4x0.5t	
4-63	MR321403	Warm Pulley	CE-1042
4-64	MB321391	AS Belt	CE-1028
4-65	ZG324331	Coil Spring T2-3.2/0.2-12.5	

5. PRE AMP P.C BOARD (CE-5301A) BLOCK

Symbol No.	Parts No.	Description	Schematic No.
5-1	BA323893	Pre Amp P.C Board Comp. CS-M01 (U/T)	CE-5301A
5-2	BA323894	Pre Amp P.C Board Comp. CS-M01 (JPN)	CE-5301A
5-3	BA320996	Pre Amp P.C Board Comp. CS-M01 (CSA)	CE-5301A
5-4	BA320995	Pre Amp P.C Board Comp. CS-M01 (AAL)	CE-5301A
5-IC1	EI605013	IC NE545B	45-8-117
5-TR1,2	ET603257	Transistor 2SC1312S(G)(H)	45-1-182
5-TR3	ET399846	Transistor 2SC945L(Q)	45-1-85
5-TR4to6	ET639437	Transistor 2SC945L(Q)(P)	45-1-85
5-TR7	ET304169	FET 2SK68(L)(M)	45-12-14
5-TR8	ET241334	Transistor 2SC1384(Q)	45-1-173
5-TR9	ET639437	Transistor 2SC945L(Q)(P)	45-1-85
5-TR10	ET307349	Transistor 2SD794(P)(Q)	45-1-334
5-TR12	ET307349	Transistor 2SD794(P)(Q)	45-1-334
5-D1to3	ED308952	Germanium Diode 1K34-LR	45-3-47
5-D4	ED624903	Silicon Diode 1S2473	45-3-28
5-D5,6	ED323979	Silicon Diode W03B	45-2-95
5-D8	ED313846	Zener Diode HZ16-3	45-6-80
5-D9	ED560913	Silicon Diode 1S2473 VE	45-3-23
5-SW1	ES310591	Slide SW. 122074	25-3-164
5-SW2	ES321274	Lever SW. 63349	25-12-65
5-SW3	ES315748	Lever SW. 83157	25-12-62
5-SW4	ES283072	Slide SW. SSC22LP (U/T, CEE, UK, CSA)	25-3-131
5-VR1	EV315413	Semi-Fixed/Vol. D8 Axial 50kB	36-10-280
5-VR2	EV315412	Semi-Fixed/Vol. D8 Axial 5kB	36-10-280
5-VR3	EV315416	Semi-Fixed/Vol. D8 Axial 10kB	36-10-280
5-VR4	EV314968	Semi-Fixed/Vol. D10 100kB	36-10-281
5-VL1	EO310608	Ferri Inductor FE-001 3.3MH	23-1-204
5-T1	EO325354	OSC Coil OSM-003	23-4-58
5-FL1	ER309119	Dolby Filter D07-001	53-1-143
5-FL2,3	EO310875	Trap Coil 7AAP-0316	23-1-296
5-J1	EJ321328	Jack HLJ0345-01-010	31-2-110
5-J2	EJ316156	Head Phone Jack HLJ0315-01-020	31-2-106
5-J3	EJ308985	DIN, Pin Jack 4P (Ext. JPN, AAL)	31-5-144
5-J3	EJ308986	Pin Jack 4P (JPN, AAL)	31-5-145
5-FR1,2	ER319510	Fuse/R. 1/4W 56 ohms(J)	35-14-23
5-FR3	ER319455	Fuse/R. F 1/4W 10 ohms(G)	35-14-31
5-R70	ER325353	Metal Oxide Film/R. 2W 15 ohms(J)	35-11-22
5-C3	EC306987	Styrol/C. 470PF(J) 50WV	24-11-14
5-C10	EC309416	Styrol/C. 200PF(J) 50WV	24-11-14
5-C53	EC321349	Polypropylene/C. 0.0022μF(J) 630WV	24-22-9
5-C67	EC565830	Styrol/C. (Vert.) 200PF(J) 50WV	24-11-3
5-5	ZW263946	Nylon Rivet 4x5	2-7-57
5-6	ZS421806	Screw, Pan 3x8	
5-7	ZW273756	Nut, #1 M3	

When ordering parts, please describe Parts Number, Description, and Model Number in detail.

6. ASSEMBLY BLOCK

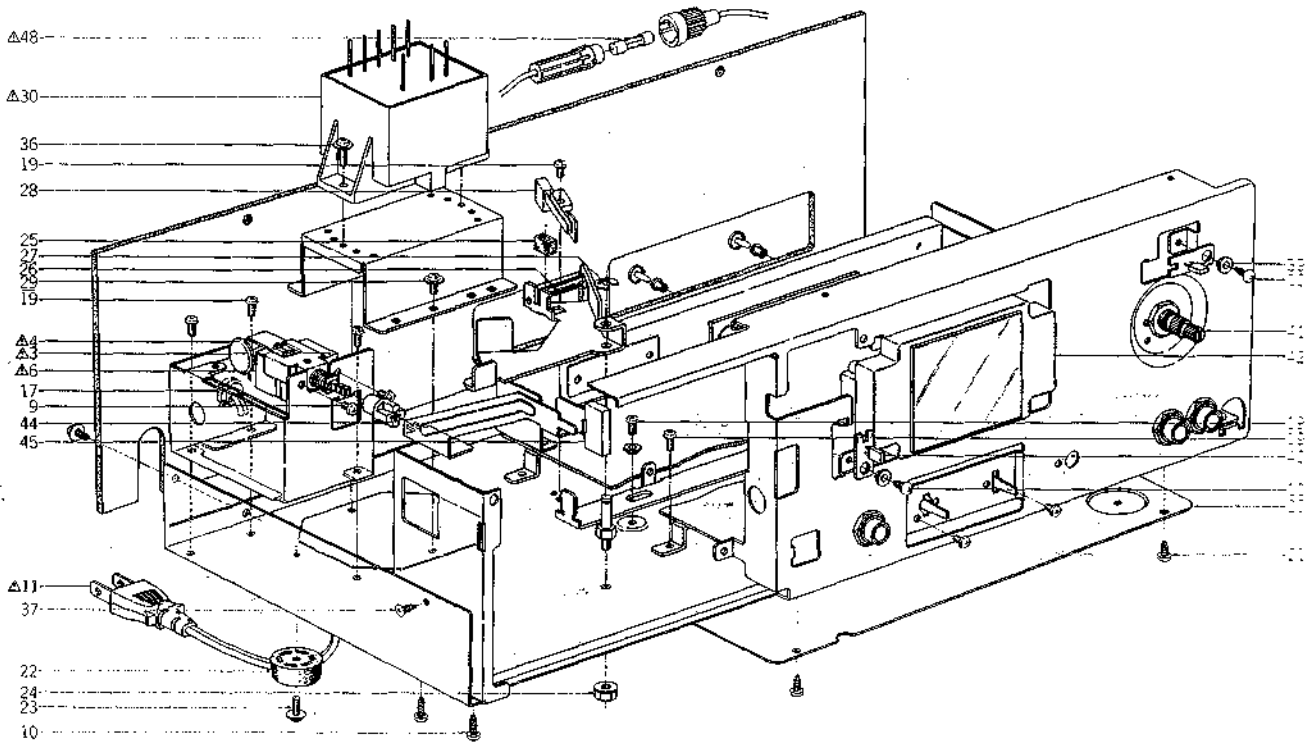

ASSEMBLY BLOCK

Ref. No.	Parts No.	Description	Schematic No.	Ref. No.	Parts No.	Description	Schematic No.
POWER SW. P.C BOARD (A) BLOCK							
6-1x	EC321302	△ Ceramic/C. E 0.01μF(Z) 250VAC (JPN)	24-5-90	6-21	ZS325495	Tapping Screw, #2 BR 3×6	
6-2x	EC314688	△ Ceramic/C. DE7150 FZ 0.01μF(P) 125W (CSA, AAL)	24-5-87	6-22	SA306240	Rubber Foot (B)	LE-6740
POWER SW. P.C BOARD (B) BLOCK							
6-3	MZ283140	△ Voltage Changer 12M-60031 (U/T)	40-2-13	6-23	ZS306463	S-Tight Screw, Pan 3×8 w/Flange	
6-4	EC321302	△ Ceramic/C. E 0.01μF(Z) 250VAC (U/T)	24-5-90	6-24	ZW413267	Flange Nut M4	
POWER SW. P.C BOARD (C) BLOCK							
6-5x	EC301320	△ MP/C. 4700PF(M) 250WV (CEE, UK, SAA)	24-9-122	6-25	MB510164	Cushion Rubber	CG-7306
CONNECTOR BASE BLOCK							
6-6	ES310839	△ Push SW. SDG1P-E 5A/80A 250V (U/T, CEE, UK, SAA)	25-5-310	6-26	ZG313048	Coil Spring T1-5.0/0.55-35.5	
6-7x	ES315159	△ Push SW. SDG1P (JPN)	25-5-330	6-27	ZW290283	'U' Ring 2.85M	6-1-1
6-8x	ES665875	△ Push SW. SDG1P-J TV-3 UL/CSA (CSA, AAL)	25-5-199	6-28	ES301747	Leaf SW. BSW-1F TX-2	25-10-30
6-9	ZS422076	Screw, Pan 3×5		6-29	ZS313490	S-Tight Screw, Pan 3×6 w/Washer	
6-10	ZS447840	Tapping Screw, #2 BR 3×8		6-30	BT323939	△ Power Trans. CET-31 (U/T)	38-4-804
6-11	EW306428	△ AC Cord (U/T)	26-3-64	6-31x	BT323940	△ Power Trans. CET-32 (JPN)	38-4-805
6-12x	EW306427	△ AC Cord (JPN)	26-3-63	6-32x	BT323942	△ Power Trans. CET-34 (CSA)	38-4-807
6-13x	EW305691	△ AC Cord CUL (CSA, AAL)	26-3-65	6-33x	BT324373	△ Power Trans. CET-35 (AAL)	38-4-848
6-14x	EW313882	△ AC Cord EC (CEE)	26-3-66	6-34x	BT323941	△ Power Trans. CET-33 (CEE)	38-4-806
6-15x	EW313884	△ AC Cord BASEC (UK)	26-3-67	6-35x	BT323944	△ Power Trans. CET-36 (UK, SAA)	38-4-808
6-16x	EW313883	△ AC Cord SAA (SAA)	26-3-69	6-36	ZS323946	S-Tight Screw, Pan 3×10 W=8	
6-17	EZ631945	Strain Relief SR-4N-4 (Ext. UK)	2-7-49	ASSEMBLY BLOCK			
6-18x	EJ692908	Strain Relief SR-5N-4 (UK)	2-7-60	6-37	ZS200676	Tapping Screw, #2 Countersunk 3×6	
AMP CHASSIS BLOCK							
6-19	ZS306021	S-Tight Screw, Pan 3×6		6-38x	ZS310984	P-Tight Screw, BR 3×8	7-1-80
6-20	SP321464	Bottom Plate	CE-5013	6-39	ED320469	LED SEL-1120R	45-15-45
				6-40	ED325330	LED SEL-1320G	45-15-46
				6-41	EV325331	Double-Axial 2-Throw/Vol. DM80R 50kA×2	36-18-22
				6-42	EM323852	VU Meter KL-270U-1	46-1-237
				6-43x	EM323854	VU Meter KL-270U-2 (BL)	46-1-238
				6-44	ML321550	Joint	CE-6205
				6-45	SB316498	Button (B)	CU-6009
				6-46x	SB316499	Button (B-BL)	CU-6009
				6-47x	EF309387	△ Fuse 1A 250V (JPN)	39-1-64
				6-48	EF623103	△ Fuse (Semko T) 1AT (U/T, CEE, UK, SAA)	39-1-53
				6-49x	EF310229	△ Fuse 1A 125V (CSA, AAL)	39-1-65

When ordering parts, please describe Parts Number, Description, and Model Number in detail.

7. FINAL ASSEMBLY BLOCK

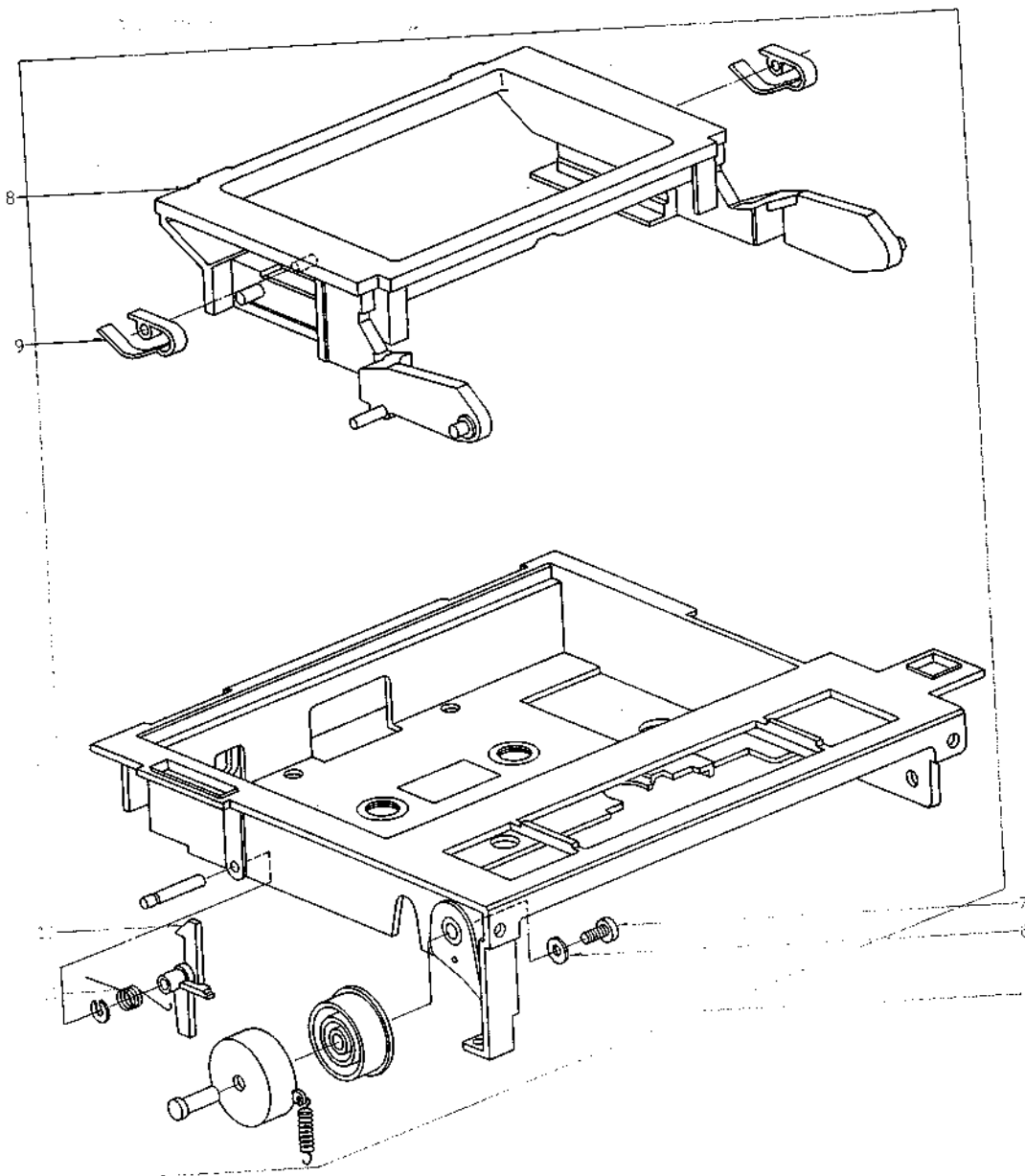
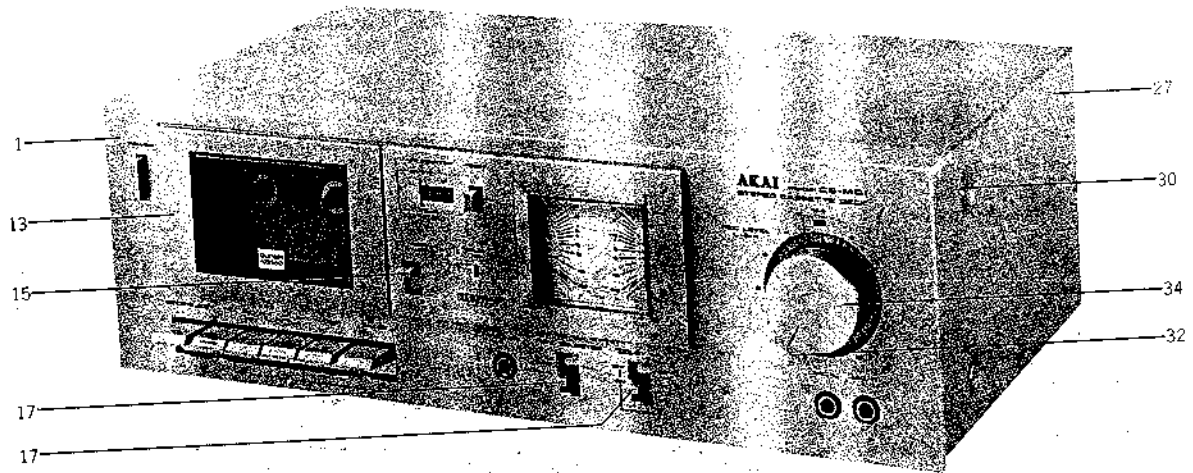

FINAL ASSEMBLY BLOCK

Ref. No.	Parts No.	Description	Schematic No.
FRONT PANEL BLOCK			
7-1	BD323921	Front Panel BLK CS-M01 (U/T)	
7-2x	BD323922	Front Panel BLK CS-M01 (JPN) (JPN, AAL)	
7-3x	BD323923	Front Panel BLK CS-M01-BL	
7-4	TC323926	Decoration Plate Assy CS-M01	CE-6315
7-5x	TC323927	Decoration Plate Assy CS-M01-BL	CE-6315
7-6	ZW550697	Washer (SPC) D2.9x7.4x0.5t	
7-7	ZS608220	Screw, Pan 2.6x6	
7-8	TC321486	LID Frame	CE-6010
7-9	ZG321487	Mold Spring	CE-6011
7-10	TC321488	Lock Plate	CE-6013
7-11	ZG321490	Lock Spring	CE-6015
7-12x	ZS322402	Special Tapping Screw, Pan 3x8	7-1-70
7-13	BD323924	LID Panel Assy CS-M01	
7-14x	BD323925	LID Panel Assy CS-M01-BL	
FINAL ASSEMBLY BLOCK			
7-15	SK321492	Timer Lever Knob	CE-6017
7-16x	SK321493	Timer Lever Knob (BL)	CE-6017
7-17	SK321500	Lever Knob (A)	CE-6025
7-18x	SK321501	Lever Knob (A-BL)	CE-6025
7-19x	ZS498273	Tapping Screw #2, BR 3x8 W=8	
7-20x	SP323828	Back Board (U/T)	CE-6309,6310
7-21x	SP323824	Back Board (JPN)	CE-6309,6310
7-22x	SP323825	Back Board (CSA)	CE-6309,6311
7-23x	SP323829	Back Board (A) (AAL)	CE-6309,6311
7-24x	SP323826	Back Board (CEE)	CE-6309,6312
7-25x	SP323827	Back Board (UK, SAA)	CE-6309,6312
7-26x	ZS225134	Tapping Screw, #2 Pan 3x10 W=8	
7-27	BC323832	Upper Cover (C)	CE-6314
7-28x	BC321508	Upper Cover (B) (AAL)	CE-6029
7-29x	BC323833	Upper Cover (C-BL)	CE-6314
7-30	ZS315878	S-Tight Screw, Bind 4x8	
7-31x	ZS310588	S-Tight Screw, Bind 4x8 (Black)	
7-32	SK321506	Double Knob (Lower)	CE-6023
7-33x	SK321507	Double Knob (Lower-BL)	CE-6028
7-34	SK323822	Double Knob (Upper)	CE-6307
7-35x	SK323823	Double Knob (Upper-BL)	CE-6307

INDEX

Parts No.	Ref. No. & Symbol No.	Parts No.	Ref. No. & Symbol No.	Parts No.	Ref. No. & Symbol No.	Parts No.	Ref. No. & Symbol No.	Parts No.	Ref. No. & Symbol No.
BA320995	5-4	EV325331	6-41	ZG321535	2-10				
BA320996	5-3	EW305691	6-13x	ZG321538	4-13				
BA323893	5-1	EW306427	6-12x	ZG321544	4-45				
BA323894	5-2	EW306428	6-11	ZG321548	4-60				
BC321508	7-28x	EW313882	6-14x	ZG321549	4-59				
BC323832	7-27	EW313883	6-16x	ZG324329	4-5				
BC323833	7-29x	EW313884	6-15x	ZG324330	4-6				
BD323921	7-1	EZ631945	6-17	ZG324331	4-65				
BD323922	7-2x	HE323856	2-3	ZG325100	4-52				
BD323923	7-3x	HP323857	2-2	ZG514440	4-8				
BD323924	7-13	MB296458	4-29	ZS200384	4-28				
BD323925	7-14x	MB321389	3-7	ZS200676	6-37				
BH323920	2-1x	MB321391	4-64	ZS225134	7-26x				
BL319692	2-8	MB326135	3-2	ZS306021	6-19				
BM319691	3-1	MB510164	6-25	ZS306463	6-23				
BR321539	4-10	MC321559	4-26	ZS310343	4-23				
BR321540	4-15	MC321560	4-27x	ZS310588	7-31x				
BT323939	6-30	ML319709	3-5	ZS310984	3-10				
BT323940	6-31x	ML319693	4-18	ZS310984	4-30				
BT323941	6-34x	ML321404	4-16	ZS310984	6-38x				
BT323942	6-32x	ML321550	6-44	ZS313490	6-29				
BT323944	6-35x	MR321403	4-63	ZS315878	7-30				
BT324373	6-33x	MT305793	4-14	ZS321320	4-32x				
BZ321546	4-51	MV368886	4-21	ZS322402	7-12x				
BZ321547	4-55	MZ283140	6-3	ZS323946	6-36				
EC301320	6-5x	MZ321396	4-7	ZS325495	6-21				
EC306987	5-C3	MZ321417	4-46	ZS419940	2-5				
EC309416	5-C10	MZ321418	4-57	ZS421806	5-6				
EC314688	6-2x	MZ321419	4-58	ZS422076	6-9				
EC321302	6-1x	SA306240	6-22	ZS447840	6-10				
EC321302	6-4	SB316498	6-45	ZS479474	3-4				
EC321349	5-C53	SB316499	6-46x	ZS498273	7-19x				
EC565830	5-C67	SK321362	4-34	ZS608106	2-4				
ED308952	5-D1to3	SK321363	4-35x	ZS608220	7-7				
ED313846	5-D8	SK321364	4-36	ZW263946	5-5				
ED320469	6-39	SK321365	4-37x	ZW269335	3-6				
ED323979	5-D5,6	SK321367	4-38	ZW270101	4-24				
ED325330	6-40	SK321368	4-39x	ZW270123	4-44				
ED560913	5-D9	SK321369	4-40	ZW273756	5-7				
ED624903	5-D4	SK321370	4-41x	ZW290283	6-27				
EF309387	6-47x	SK321492	7-15	ZW305546	4-19				
EF310229	6-49x	SK321493	7-16x	ZW319376	4-50				
EF623103	6-48	SK321500	7-17	ZW321317	4-62				
EI605013	5-IC1	SK321501	7-18x	ZW321393	4-12				
EJ308985	5-J3	SK321506	7-32	ZW321424	3-9				
EJ308986	5-J3	SK321507	7-33x	ZW321437	4-20				
EJ316156	5-J2	SK323822	7-34	ZW340648	4-17				
EJ321328	5-J1	SK323823	7-35x	ZW357164	2-11				
EJ692908	6-18x	SP321464	6-20	ZW381644	4-11				
EL323981	4-33	SP323824	7-21x	ZW413267	6-24				
EM323852	6-42	SP323825	7-22x	ZW460787	4-53				
EM323854	6-43x	SP323826	7-24x	ZW550642	3-3				
EO310608	5-VL1	SP323827	7-25x	ZW550697	7-6				
EO310875	5-FL2,3	SP323828	7-20x	ZW653163	4-54				
EO325354	5-T1	SP323829	7-23x						
ER309119	5-FL1	TC282396	4-9						
ER319455	5-FR3	TC319723	4-1						
ER319510	5-FR1,2	TC319724	4-61						
ER325353	5-R70	TC319914	3-8						
ES283072	5-SW4	TC321415	4-47						
ES283173	4-31	TC321486	7-8						
ES301747	6-28	TC321488	7-10						
ES310591	5-SW1	TC323926	7-4						
ES310839	6-6	TC323927	7-5x						
ES315159	6-7x	ZG300206	2-9						
ES315748	5-SW3	ZG312920	4-56						
ES321274	5-SW2	ZG312926	4-2						
ES665875	6-8x	ZG312943	4-4						
ET241334	5-TR8	ZG313048	6-26						
ET304169	5-TR7	ZG318228	4-49						
ET307349	5-TR10	ZG321358	2-7						
ET307349	5-TR12	ZG321373	4-3						
ET399846	5-TR3	ZG321384	4-22						
ET603257	5-TR1,2	ZG321411	4-25						
ET639437	5-TR4to6	ZG321416	4-48						
ET639437	5-TR9	ZG321430	4-42						
EV314968	5-VR4	ZG321431	4-43						
EV315412	5-VR2	ZG321459	2-6						
EV315413	5-VR1	ZG321487	7-9						
EV315416	5-VR3	ZG321490	7-11						

SECTION 3

SCHEMATIC DIAGRAM

1. SCHEMATIC DIAGRAM OF IC
2. CS-M01 NO. 1600416A SCHEMATIC DIAGRAM

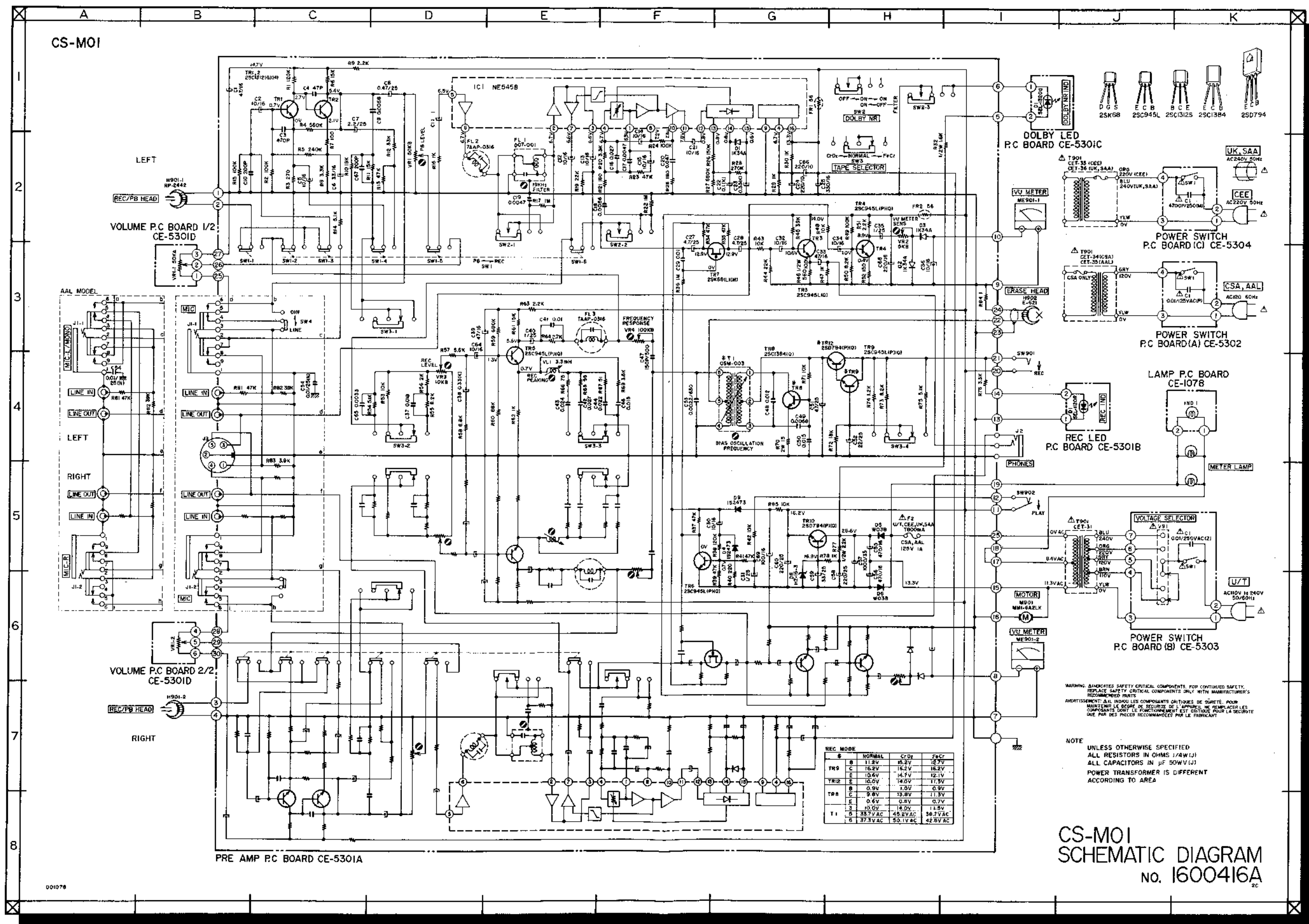

REC. MODE	NORMAL	Cr. Dr.	Fa Cr.
TR9	C 11.2V	8.2V	12.7V
	B 16.2V	16.2V	16.2V
	E 13.6V	14.7V	12.1V
TR12	F 0.6V	1.0V	1.15V
TR8	B 0.9V	1.0V	0.9V
	C 0.8V	13.8V	11.5V
	E 0.6V	0.6V	0.7V
	F 0.05V	18.0V	11.5V
T1	257VAC	45.2VAC	50.7VAC
	B 27.3VAC	50.1VAC	42.8VAC

WARNING: INDICATES SAFETY CRITICAL COMPONENTS FOR CONTINUED SAFETY. REPLACE SAFETY CRITICAL COMPONENTS ONLY WITH MANUFACTURER'S RECOMMENDED PARTS.

AVERTISSEMENT: A.I.L. INDIQUE LES COMPOSANTS CRITIQUES DE SURETE. POUR MAINTENIR LE DEGRÉ DE SECURITE DE L'APPAREIL, NE REMPLACEZ LES COMPOSANTS QUE SI LE FONCTIONNEMENT EST CERTAINE POUR LA SECURITE. UNE POUR DES PRECIS RECOMMANDEES PAR LE FABRICANT.

NOTE: UNLESS OTHERWISE SPECIFIED ALL RESISTORS IN OHMS (1/4W (J)) ALL CAPACITORS IN µF (50V (J)) POWER TRANSFORMER IS DIFFERENT ACCORDING TO AREA

CS-M01 SCHEMATIC DIAGRAM No. 1600416A